



TEST REPORT

Test Report No. : UL-RPT-RP-12397124-116-FCC

Applicant : Kathrein Sachsen GmbH
Model No. : 52010297-000
FCC ID : WJ9-RRU4560
Technology : RFID 915 MHz
Test Standard(s) : FCC Parts 15.207, 15.209 & 15.247

For details of applied tests refer to test result summary

1. This test report shall not be reproduced in full or partial, without the written approval of UL International Germany GmbH.
2. The results in this report apply only to the sample tested.
3. The test results in this report are traceable to the national or international standards.
4. Test Report Version 1.1 – Supersede Version 1.0
5. Result of the tested sample: **PASS**

Prepared by: Abdoufataou Salifou
Title: Laboratory Engineer
Date: 26 September 2018

Approved by: Ajit Phadtare
Title: Lead Test Engineer
Date: 26 September 2018



Deutsche
Akkreditierungsstelle
D-PL-19381-02-00

This laboratory is accredited by DAkkS.
The tests reported herein have been performed in
accordance with its' terms of accreditation.

This page has been left intentionally blank.

Table of Contents

1. Customer Information.....	4
1.1.Applicant Information	4
1.2.Manufacturer Information	4
2. Summary of Testing.....	5
2.1. General Information	5
Applied Standards	5
Location	5
Date information	5
2.2. Summary of Test Results	6
2.3. Methods and Procedures	6
2.4. Deviations from the Test Specification	6
3. Equipment Under Test (EUT)	7
3.1. Identification of Equipment Under Test (EUT)	7
3.2. Description of EUT	7
3.3. Modifications Incorporated in the EUT	7
3.4. Additional Information Related to Testing	8
3.5. Antenna Information	9
3.6. Support Equipment	10
A. Support Equipment (In-house)	10
B. Support Equipment (Manufacturer supplied)	10
4. Operation and Monitoring of the EUT during Testing	11
4.1. Operating Modes	11
4.2. Configuration and Peripherals	11
4.3. Used Power settings	11
5. Measurements, Examinations and Derived Results	12
5.1. General Comments	12
5.2. Test Results	13
5.2.1. Transmitter AC Conducted Spurious Emissions	13
5.2.2. Transmitter 20 dB Bandwidth	16
5.2.3. Transmitter Carrier Frequency Separation	18
5.2.4. Transmitter Number of Hopping Frequencies and Average Time of Occupancy	20
5.2.5. Transmitter Maximum Peak Output Power	23
5.2.6. Transmitter Conducted Emissions	29
5.2.7. Transmitter Band Edge Radiated Emissions	43
6. Measurement Uncertainty	58
7. Used equipment	59
8. Report Revision History	61

1. Customer Information

1.1.Applicant Information

Company Name:	Kathrein Sachsen GmbH
Company Address:	Lindenstrasse 3, 09241 Muehlau
Contact Person:	Daniel Schkalda
Contact E-Mail:	d.schkalda@kathrein-sachsen.de
Contact Phone No.:	+49 3722 6073 79

1.2.Manufacturer Information

Company Name:	Kathrein Sachsen GmbH
Company Address:	Lindenstrasse 3, 09241 Muehlau
Contact Person:	Daniel Schkalda
Contact E-Mail:	d.schkalda@kathrein-sachsen.de
Contact Phone No.:	+49 3722 6073 79

2. Summary of Testing

2.1. General Information

Applied Standards

Specification Reference:	47CFR15.247
Specification Title:	Code of Federal Regulations Volume 47 (Telecommunications): Part 15 Subpart C (Intentional Radiators) - Section 15.247
Specification Reference:	47CFR15.207 and 47CFR15.209
Specification Title:	Code of Federal Regulations Volume 47 (Telecommunications): Part 15 Subpart C (Intentional Radiators) - Sections 15.207 and 15.209
Test Firm Registration:	399704

Location

Location of Testing:	UL International Germany GmbH Hedelfinger Str. 61 70327 Stuttgart Germany
-----------------------------	--

Date information

Order Date:	04 July 2018
EUT arrived:	24 July 2018
Test Dates:	06 August 2018 to 26 September 2018
EUT returned:	-/-

2.2. Summary of Test Results

Clause	Measurement	Complied	Did not comply	Not performed	Not applicable
Part 15.207	Transmitter AC Conducted Emissions	<input checked="" type="checkbox"/>	<input type="checkbox"/>	<input type="checkbox"/>	<input type="checkbox"/>
Part 15.247(a)(1)	Transmitter 20 dB Bandwidth	<input checked="" type="checkbox"/>	<input type="checkbox"/>	<input type="checkbox"/>	<input type="checkbox"/>
Part 15.247(a)(1)	Transmitter Carrier Frequency Separation	<input checked="" type="checkbox"/>	<input type="checkbox"/>	<input type="checkbox"/>	<input type="checkbox"/>
Part 15.247(a)(1)(i)	Transmitter Number of Hopping Frequencies and Average Time of Occupancy	<input checked="" type="checkbox"/>	<input type="checkbox"/>	<input type="checkbox"/>	<input type="checkbox"/>
Part 15.247(b)(2)	Transmitter Maximum Peak Output Power	<input checked="" type="checkbox"/>	<input type="checkbox"/>	<input type="checkbox"/>	<input type="checkbox"/>
Part 15.247(d)	Transmitter Conducted Emissions	<input checked="" type="checkbox"/>	<input type="checkbox"/>	<input type="checkbox"/>	<input type="checkbox"/>
Part 15.247(d) & 15.209(a)	Transmitter Radiated Emissions	<input checked="" type="checkbox"/>	<input type="checkbox"/>	<input type="checkbox"/>	<input type="checkbox"/>
Part 15.247(d) & 15.209(a)	Transmitter Band Edge Radiated Emissions	<input checked="" type="checkbox"/>	<input type="checkbox"/>	<input type="checkbox"/>	<input type="checkbox"/>

Notes:

2.3. Methods and Procedures

Reference:	ANSI C63.10-2013
Title:	American National Standard of Procedures for Compliance Testing of Unlicensed Wireless Devices
Reference:	KDB 174176 D01 Line Conducted FAQ v01r01 June 3, 2015
Title:	AC Power-Line Conducted Emissions Frequently Asked Questions

2.4. Deviations from the Test Specification

For the measurements contained within this test report, there were no deviations from, additions to, or exclusions from the test specification identified above.

3. Equipment Under Test (EUT)

3.1. Identification of Equipment Under Test (EUT)

Brand Name:	KATHREIN
Model Name or Number:	52010297-000
Test Sample Serial Number:	GOK4485954
Hardware Version Number:	52010297-000
Firmware Version Number:	03.03.03
FCC ID:	WJ9-RRU4560

3.2. Description of EUT

The equipment under test was a UHF RFID Tag Reader with an integrated wireless LAN module.

3.3. Modifications Incorporated in the EUT

No modifications were applied to the EUT during testing.

3.4. Additional Information Related to Testing

Tested Technology:	RFID 902-928 MHz (FHSS)		
Power Supply Requirement:	Nominal	90 - 264(V AC)	
Type of Unit:	Transceiver		
Channel Spacing:	500 kHz		
Modulation:	PR-ASK		
Data Rate (kbps):	40	80	160
Transmit Frequency Range:	902 MHz to 928 MHz		
Transmit Channels Tested:	Channel ID	Channel Number	Channel Frequency (MHz)
	Bottom	1	902.25
	Middle	26	915.25
	Top	52	927.75

3.5. Antenna Information

Antenna Name:	WIRA-70-KRAI-FCC
Antenna Type:	Wide Range Patch Antenna 902MHz - 928MHz ©KRAI
Antenna Gain:	7.5 dBi / 6.5 dBiC
Antenna Beamwidth:	h/v: 69°
Antenna Polarisation:	LHCP/ RHCP/ HP/ VP

Antenna Name:	SMSH-30-30-ETSI-FCC
Antenna Type:	Smart Shelf Antenna 865-928MHz ©KRAI
Antenna Gain:	-10 dBi/ -7 dBiC
Antenna Beamwidth:	h/v: 60°
Antenna Polarisation:	Circular

Antenna Name:	WIRA-40-linear-FCC
Antenna Type:	Wide Range Antenna 902-928MHz
Antenna Gain:	10 dBi / 13 dBiC
Antenna Beamwidth:	h/v: 40°
Antenna Polarisation:	Linear

Antenna Name:	WIRA-30-circular-FCC
Antenna Type:	Wide Range Antenna 902MHz - 928MHz
Antenna Gain:	8 dBi / 11 dBiC
Antenna Beamwidth:	h/v: 70°/30°
Antenna Polarisation:	Circular

3.6. Support Equipment

The following support equipment was used to exercise the EUT during testing:

A. Support Equipment (In-house)

Item	Description	Brand Name	Model Name or Number	Serial Number
1	USB Extension Cable	Not marked/stated	Not marked/stated	Not marked/stated
2	Laptop	Lenovo	L560	MP-16X73B 16/11

B. Support Equipment (Manufacturer supplied)

Item	Description	Brand Name	Model Name or Number	Serial Number
1	RRU/ARU AC/DC Adapter 24V/90 W (Power cord M12 coded)	MEAN WELL	GST90A24	EB79F85440
2	POE/LAN Cable (M12x Coded to RJ45) 5.0 m 94F 4x2xAWG26	KATHREIN	Art Nr. 1407473	Not marked
3	Antenna RF Cable R-AC 3 TNC-TNCR (LL 240 flex) 3.0 m 1 dB	KATHREIN	Art Nr. 52010174	Not marked

4. Operation and Monitoring of the EUT during Testing

4.1. Operating Modes

The EUT was tested in the following operating mode(s):

Transmitting Mode (Fixed Frequency Mode) Transmitting Mode (Frequency Hopping Mode)

4.2. Configuration and Peripherals

The EUT was tested in the following configuration(s):

- The EUT was powered by 120 V AC 60Hz power supply.
- The test mode settings were activated using a software application ReaderStart V3, rev.3.01.03.2531 on the laptop PC supplied by the customer. The application was used to enable continuous transmission and to select the test channels as required.
- EUT was tested with maximum output power in both fixed channel frequencies and in hopping channels mode.
- EUT's unused ports (Port 1 | Port 3 | Port 4) were terminated using 50 Ohm termination during testing.
- For Conducted tests EUT's test port (Port 2) was connected to spectrum analyzer. The measured values takes into consideration the external attenuation correction factors. The RF cable attenuation from the EUT to Analyzer including the 10 dB attenuation at the Spectrum Analyzer input was added as a reference level offset (10.2 dB) to each of the conducted plots.
- For Radiated tests EUT's test port (Port 2) was connected to Antenna using RF cable supplied by the customer. This cable introduced a loss of 1dB @ 902-928MHz. This has been taken in to account with the measured radiated values."
- EUT supports three data rates (40 kbps / 80 kbps/160 kbps) out of which worst case (40 kbps) data rate producing maximum peak power has been tested.
- All the supplied antennas as given in section 3.5 have been tested. It is to be noted that the WIRA-70-KRAI -FCC Antenna supports several polarizations (LHCP/ RHCP & HP/ VP) and all the supported polarisations have been tested.

4.3. Used Power settings

The EUT was configured with the settings below based on the different antenna type. The antenna gain on the GUI was set to 0 dBi and Cable attenuation was set to 0 dB.

The port power settings selected in GUI is given as in the table below.

WIRA-40-linear-FCC	26
WIRA-30-circular-FCC	26
SMSH-30-30-ETSI-FCC	30
WIRA-70-KRAI-FCC	30

5. Measurements, Examinations and Derived Results

5.1. General Comments

Measurement uncertainties are evaluated in accordance with current best practice. Our reported expanded uncertainties are based on standard uncertainties, which are multiplied by an appropriate coverage factor to provide a statistical confidence level of approximately 95%. Please refer to Section 6 *Measurement Uncertainty* for details.

In accordance with DAkkS requirements all the measurement equipment is on a calibration schedule. All equipment was within the calibration period on the date of testing.

5.2. Test Results

5.2.1. Transmitter AC Conducted Spurious Emissions

Test Summary:

Test Engineer:	M. Asim Shahzad	Test Date:	20 August 2018
Test Sample Serial Number:	GOK4485954		
Test Site Identification	SR 7/8		

FCC Reference:	Part 15.207
Test Method Used:	ANSI C63.10 Section 6.2 / FCC KDB 174176 and notes below

Environmental Conditions:

Temperature (°C):	24
Relative Humidity (%):	46

Settings of the Instrument

Detector	Quasi Peak /Average Peak
-----------------	--------------------------

Note:

1. The EUT was connected to 120 VAC 60 Hz single phase supply via a LISN.
2. The EUT was tested in Hopping Mode with WIRA-70-KRAI-FCC Antenna.

Test setup:

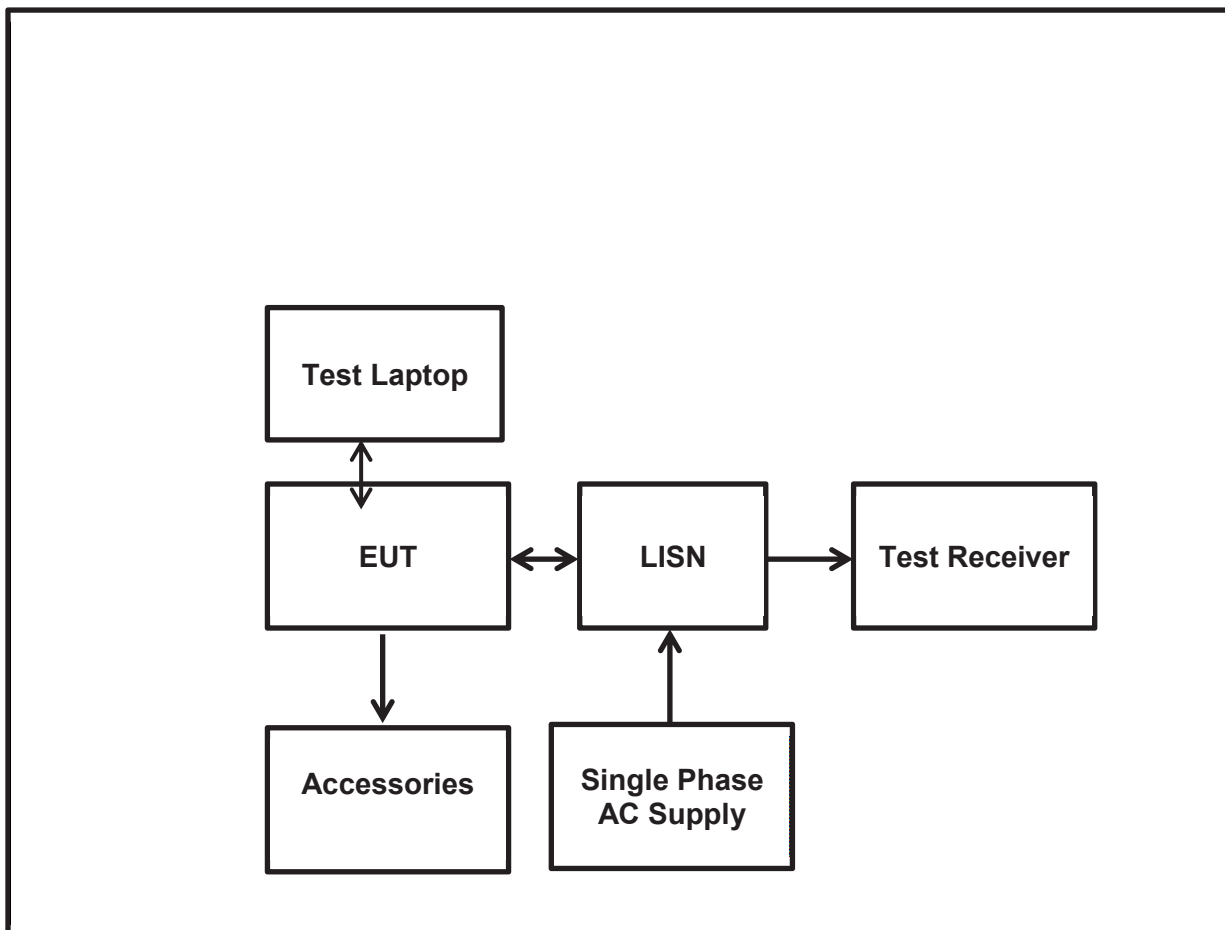

Transmitter AC Conducted Spurious Emissions (continued)**Results: Live / Quasi Peak / 120 VAC 60 Hz**

Frequency (MHz)	Line	Level (dB μ V)	Limit (dB μ V)	Margin (dB)	Result
0.15939	Live	38.7	65.5	26.8	Complied
0.21393	Live	32.0	63.1	31.1	Complied
0.38122	Live	21.7	58.3	36.6	Complied
1.12872	Live	17.8	56	38.2	Complied
11.55636	Live	24.2	60	35.8	Complied
19.18002	Live	28.2	60	31.8	Complied

Results: Live / Average / 120 VAC 60 Hz

Frequency (MHz)	Line	Level (dB μ V)	Limit (dB μ V)	Margin (dB)	Result
0.15939	Live	27.3	55.5	28.2	Complied
0.21393	Live	16.6	53.1	36.5	Complied
0.38122	Live	12.6	48.3	35.7	Complied
1.12872	Live	7.3	46	38.7	Complied
11.55636	Live	17.5	50	32.5	Complied
19.18002	Live	22.2	50	27.8	Complied

Results: Neutral / Quasi Peak / 120 VAC 60 Hz

Frequency (MHz)	Line	Level (dB μ V)	Limit (dB μ V)	Margin (dB)	Result
0.19941	Neutral	33	63.6	30.6	Complied
0.34163	Neutral	21.4	59.2	37.8	Complied
1.12896	Neutral	24.9	56	31.1	Complied
5.9599	Neutral	19.5	60	40.5	Complied
10.33523	Neutral	24	60	36	Complied
18.79321	Neutral	29.8	60	30.2	Complied

Results: Neutral / Average / 120 VAC 60 Hz

Frequency (MHz)	Line	Level (dB μ V)	Limit (dB μ V)	Margin (dB)	Result
0.19941	Neutral	16.4	53.6	37.2	Complied
0.34163	Neutral	10.7	49.2	38.5	Complied
1.12896	Neutral	12.3	46	33.7	Complied
5.9599	Neutral	13	50	37	Complied
10.33523	Neutral	17.3	50	32.7	Complied
18.79321	Neutral	23.8	50	26.2	Complied

Result: Pass

Transmitter AC Conducted Spurious Emissions (continued)

Plot: Live and Neutral Line

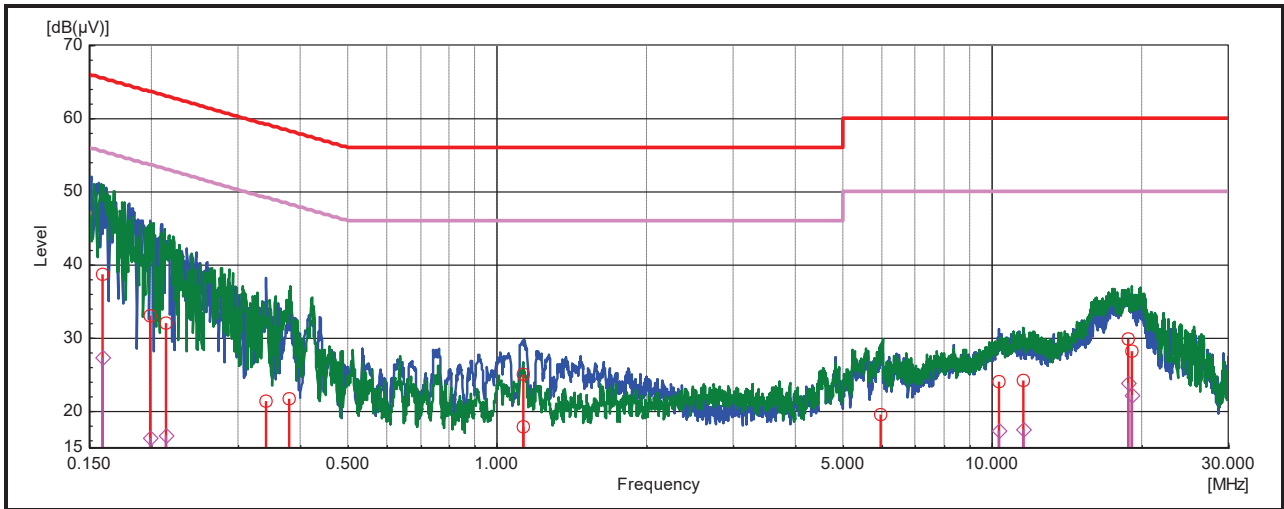

Note: These plots are pre-scans and for indication purposes only. For final measurements, see accompanying tables.

5.2.2. Transmitter 20 dB Bandwidth

Test Summary:

Test Engineer:	Abdoufataou Salifou	Test Date:	06 August 2018
Test Sample Serial Number:	GOK4485954		
Test Site Identification	SR 9		

FCC Reference:	Part 15.247(a)(1)
Test Method Used:	ANSI C63.10 Section 6.9.2

Environmental Conditions:

Temperature (°C):	24.7
Relative Humidity (%):	48

Notes:

1. The test receiver resolution bandwidth was set to 3 kHz and video bandwidth 10 kHz. A Peak detector was used, sweep time was set to auto and the trace mode was Max Hold. The span was set to 0.5 MHz. Normal and delta markers were placed 20 dB down from the peak of the carrier. These results are documented in the table below.
2. The test receiver was connected to the RF port on the EUT using suitable attenuation and RF cable.

Test setup:

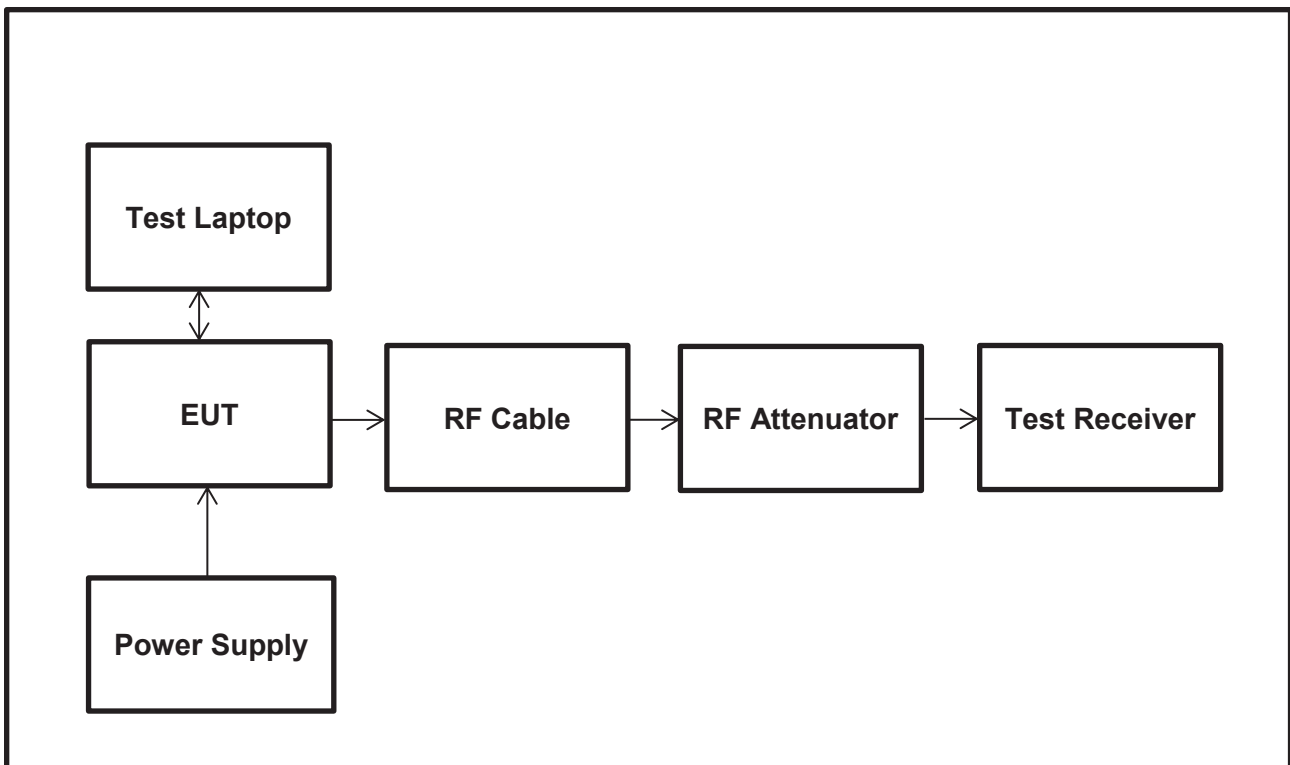

Transmitter 20 dB Bandwidth

Results :

Channel	20 dB Bandwidth (kHz)
Bottom	41.530
Middle	41.530
Top	41.530

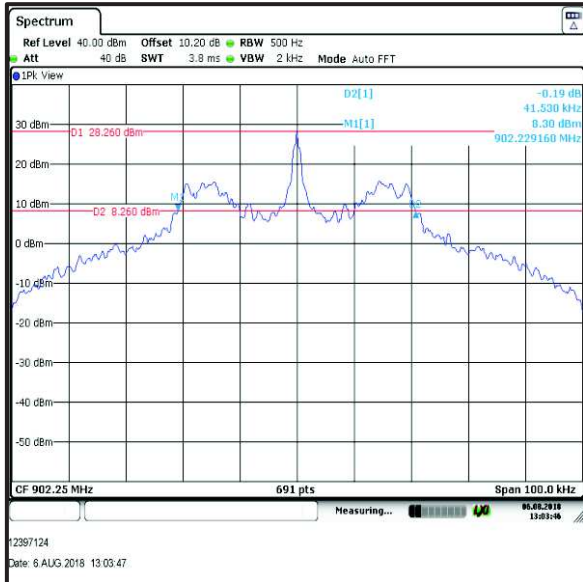

Bottom Channel



Middle Channel

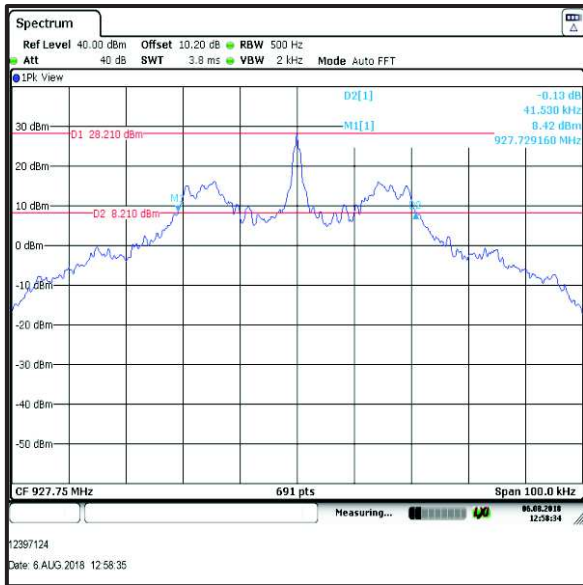

Top Channel

Result: **Pass**

5.2.3. Transmitter Carrier Frequency Separation

Test Summary:

Test Engineer:	Abdoufataou Salifou	Test Date:	07 August 2018
Test Sample Serial Number:	GOK4485954		
Test Site Identification	SR 9		

FCC Reference:	Part 15.247(a)(1)
Test Method Used:	ANSI C63.10 Section 7.8.2

Environmental Conditions:

Temperature (°C):	24
Relative Humidity (%):	48

Notes:

1. The 20 dB bandwidth measured for the middle channel operating at 915.25 MHz was used to calculate the limit.
2. The test receiver resolution bandwidth was set to 30 kHz and video bandwidth of 100 kHz. A peak detector was used, sweep time was set to auto and trace mode was Max Hold. The span was set to 1 MHz. A marker was placed at the centre of one signal and then a delta marker was placed in the same place on the second signal, the results are recorded in the table below.
3. The test receiver was connected to the RF port on the EUT using suitable attenuation and RF cable.

Test setup:

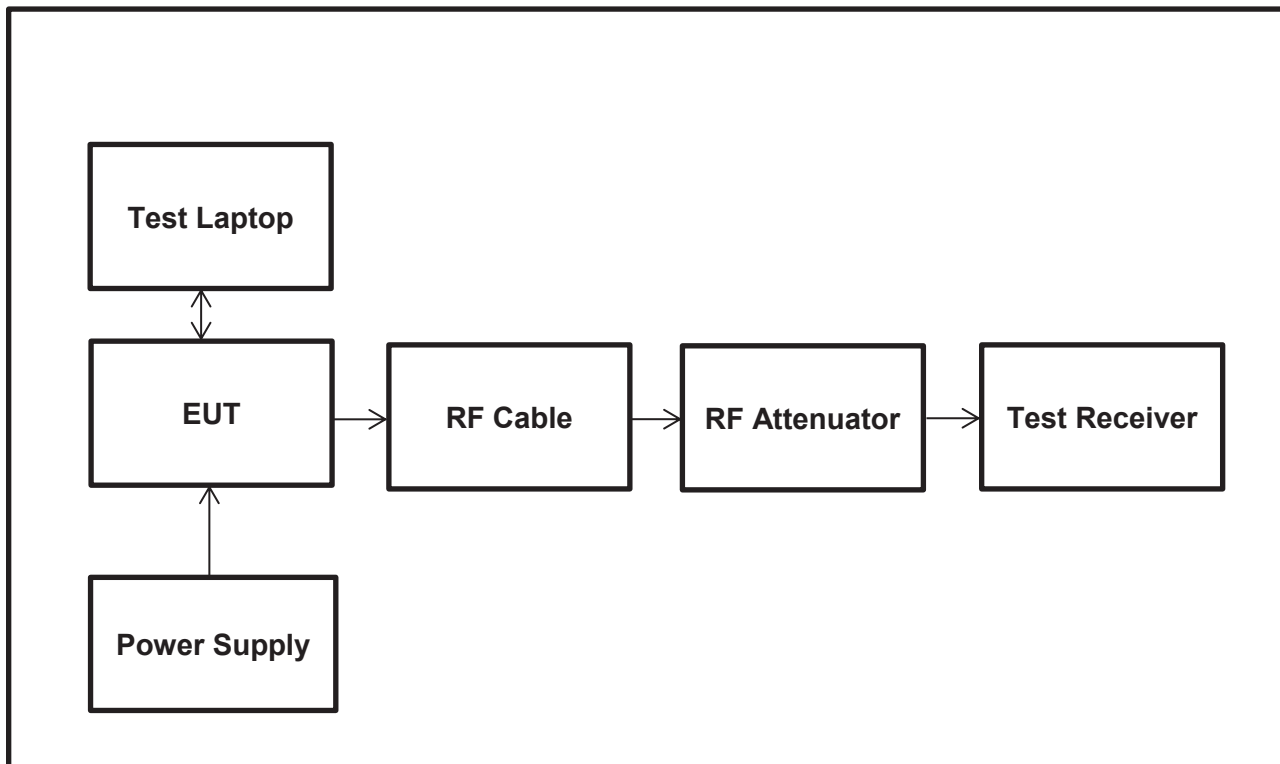

Transmitter Carrier Frequency Separation

Results:

Carrier Frequency Separation (kHz)	Limit (20 dB BW) (kHz)	Margin (kHz)	Result
499.300	41.530	457.770	Complied

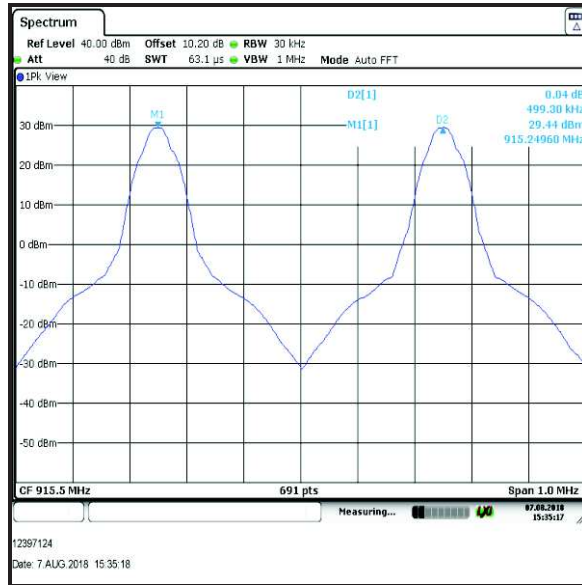

Result: Pass

5.2.4. Transmitter Number of Hopping Frequencies and Average Time of Occupancy**Test Summary:**

Test Engineer:	Abdoufataou Salifou	Test Date:	24 August 2018
Test Sample Serial Number:	GOK4485954		
Test Site Identification	SR 9		

FCC Reference:	Part 15.247(a)(1)(i)
Test Method Used:	ANSI C63.10 Sections 7.8.3 & 7.8.4

Environmental Conditions:

Temperature (°C):	21
Relative Humidity (%):	46

Notes:

1. For frequency hopping systems operating in the 902-928 MHz band: if the 20 dB bandwidth of the hopping channel is less than 250 kHz, the system shall use at least 50 hopping frequencies and the average time of occupancy on any frequency shall not be greater than 0.4 seconds within a 20 second period.
2. The test receiver was set up for the Number of Hopping Frequencies measurement as follows: the resolution bandwidth was set to 30 kHz and video bandwidth of 100 kHz. A peak detector was used, sweep time was set to auto and trace mode was Max Hold. The span was set to 28 MHz
3. The test receiver was set up for the Emission Width measurement as follows: the resolution bandwidth was set to 10 kHz and video bandwidth of 30 kHz. A peak detector was used and sweep time was set to auto with a span of zero Hz. The emission width is recorded in the table below
4. The test receiver was set up for the Number of Hopping Frequencies in 2 seconds measurement as follows: the resolution bandwidth was set to 30 kHz and video bandwidth of 100 kHz. A peak detector was used and sweep time was set to 2 seconds. The EUT was set to transmit in a hopping frequency mode with zero span. The total number of hopping frequencies were recorded in the table below.
5. The test receiver was connected to the RF port on the EUT using suitable attenuation and RF cable.

**Transmitter Number of Hopping Frequencies and Average Time of Occupancy
(continued)**

Test setup:

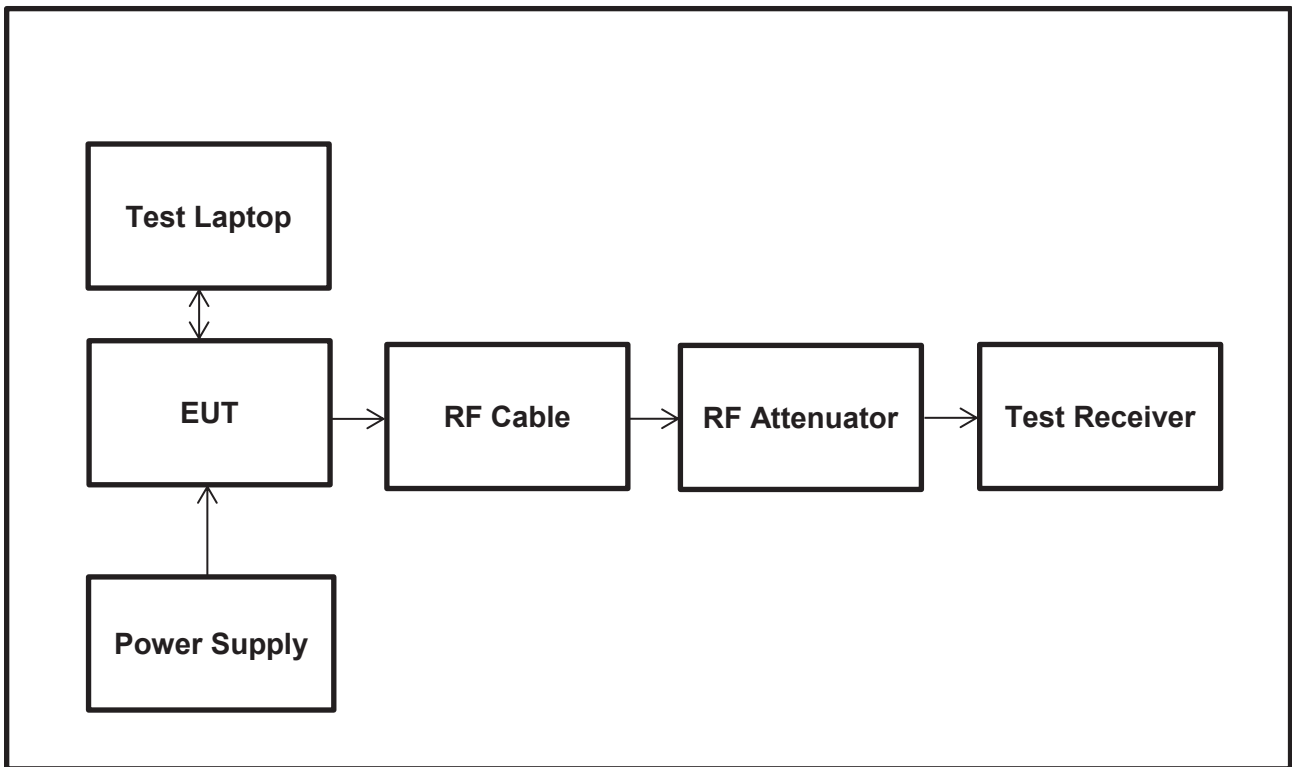

Transmitter Number of Hopping Frequencies and Average Time of Occupancy (continued)

Results:

Emission Width (ms)	Number of Hops in 20 s	Average Time of Occupancy (s)	Limit (s)	Margin (s)	Result
0.376	1	0.376	0.4	0.024	Complied

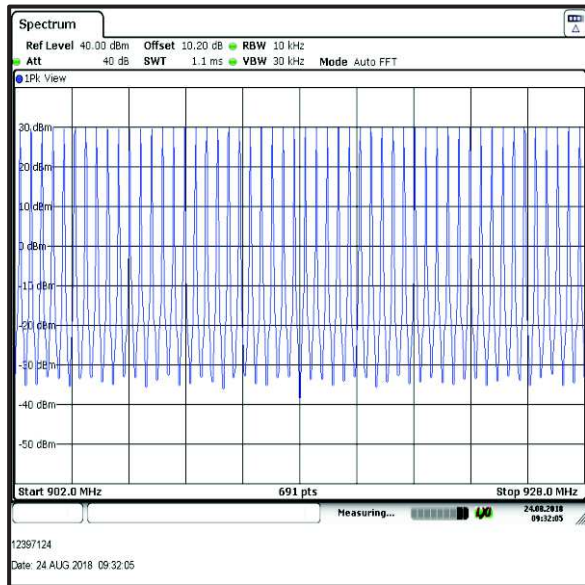

Number of Hopping Frequencies



Emission Width

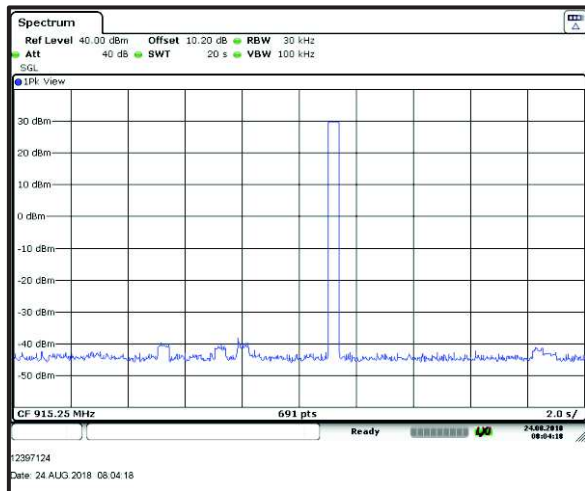

Average Time of Occupancy in 20 s

Result: **Pass**

5.2.5. Transmitter Maximum Peak Output Power**Test Summary:**

Test Engineer:	Abdoufataou Salifou, Segun I. Adeniji	Test Date:	06 August 2018 & 26 September 2018
Test Sample Serial Number:	GOK4485954		
Test Site Identification	SR 9		

FCC Reference:	Part 15.247(b)(2)
Test Method Used:	ANSI C63.10 Section 7.8.5

Environmental Conditions:

Temperature (°C):	24
Relative Humidity (%):	48

Notes:

1. The test receiver resolution bandwidth was set to 50 kHz (20 dB bandwidth) and video bandwidth of 20 kHz. A peak detector was used, sweep time was set to auto and trace mode was Max Hold. The span was set to 200 kHz (approximately five times the 20 dB bandwidth). A marker was placed at the peak of the signal and the results recorded in the tables below.
2. These tests were performed radiated; therefore the EUT antenna gain is encompassed in the final result and not measurable.
3. The declared antenna gain was added to the conducted peak power to obtain the EIRP.
4. The test receiver was connected to the RF port on the EUT using suitable attenuation and RF cable. An RF offset level was entered on the test receiver to compensate for the loss of the attenuator and RF cable.

Test setup:

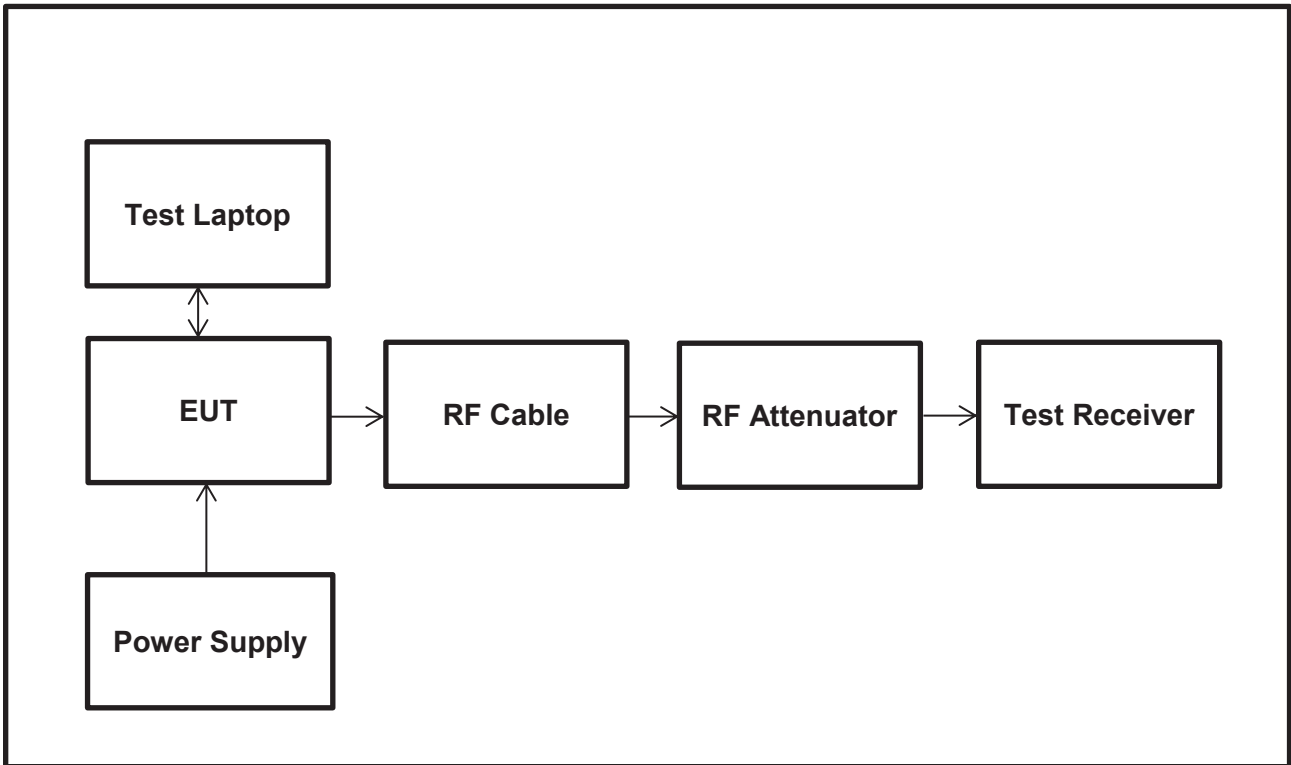

Transmitter Maximum Peak Output Power (continued)**Results: Valid for Antenna Type: WIRA-40-linear-FCC & WIRA-30-circular-FCC**

Channel	Conducted Peak Power (dBm)	Conducted Peak Power Limit (dBm)	Margin (dB)	Result
Bottom	24.97	30.0	5.03	Complied
Middle	24.97	30.0	5.03	Complied
Top	24.97	30.0	5.03	Complied

Results: Valid for Antenna Type: SSMH-30-30-ETSI-FCC & WIRA-70-KRAI-FCC

Channel	Conducted Peak Power (dBm)	Conducted Peak Power Limit (dBm)	Margin (dB)	Result
Bottom	28.26	30.0	1.74	Complied
Middle	28.24	30.0	1.76	Complied
Top	28.39	30.0	1.61	Complied

Transmitter Maximum Peak Output Power / Antenna Type: WIRA-40-linear-FCC

Channel	Conducted Peak Power (dBm)	Declared Antenna Gain (dBi)	EIRP (dBm)	De Facto EIRP Limit (dBm)	Margin (dB)	Result
Bottom	24.97	10	34.97	36.0	1.03	Complied
Middle	24.97	10	34.97	36.0	1.03	Complied
Top	24.97	10	34.97	36.0	1.03	Complied

Transmitter Maximum Peak Output Power / Antenna Type: WIRA-30-circular-FCC

Channel	Conducted Peak Power (dBm)	Declared Antenna Gain (dBi)	EIRP (dBm)	De Facto EIRP Limit (dBm)	Margin (dB)	Result
Bottom	24.97	8	32.97	36.0	3.03	Complied
Middle	24.97	8	32.97	36.0	3.03	Complied
Top	24.97	8	32.97	36.0	3.03	Complied

Transmitter Maximum Peak Output Power / Antenna Type: WIRA-70-KRAI-FCC

Channel	Conducted Peak Power (dBm)	Declared Antenna Gain (dBi)	EIRP (dBm)	De Facto EIRP Limit (dBm)	Margin (dB)	Result
Bottom	28.26	7.5	35.76	36.0	0.24	Complied
Middle	28.24	7.5	35.74	36.0	0.26	Complied
Top	28.39	7.5	35.89	36.0	0.11	Complied

Transmitter Maximum Peak Output Power / Antenna Type: SSMH-30-30-ETSI-FCC

Channel	Conducted Peak Power (dBm)	Declared Antenna Gain (dBi)	EIRP (dBm)	De Facto EIRP Limit (dBm)	Margin (dB)	Result
Bottom	28.26	-10	18.26	36.0	17.74	Complied
Middle	28.24	-10	18.24	36.0	17.76	Complied
Top	28.39	-10	18.39	36.0	17.61	Complied

Result: **Pass**

Transmitter Maximum Peak Output Power (continued)

Results: Antenna Type: WIRA-40-linear-FCC & WIRA-30-circular-FCC

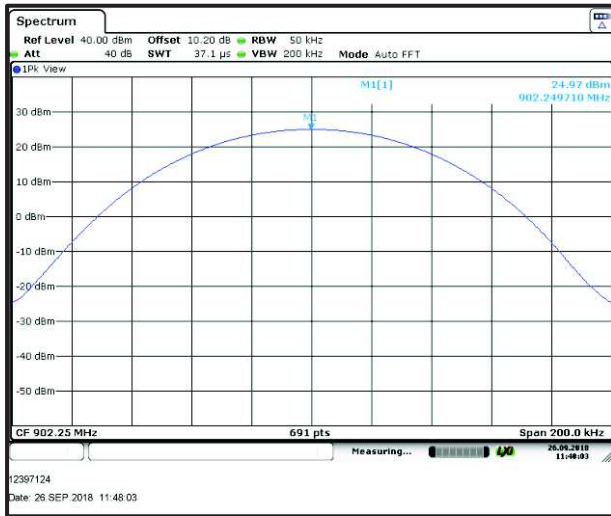

Bottom Channel



Middle Channel



Top Channel

Transmitter Maximum Peak Output Power (continued)

Results: WIRA-70-KRAI-FCC & SMSH-30-30-ETSI-FCC



Bottom Channel

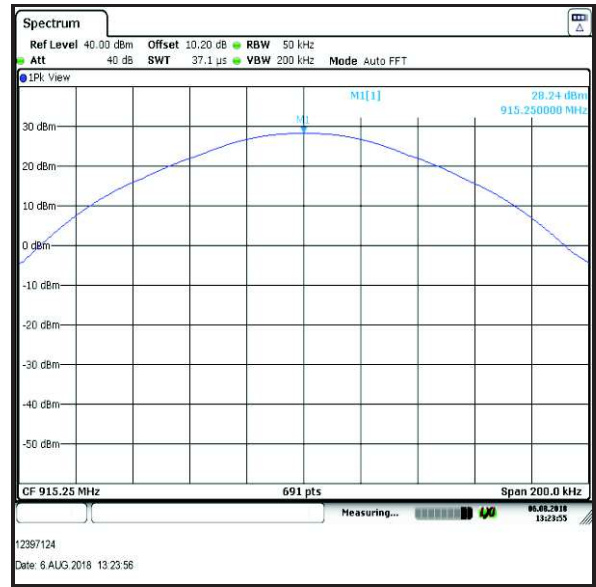

Middle Channel

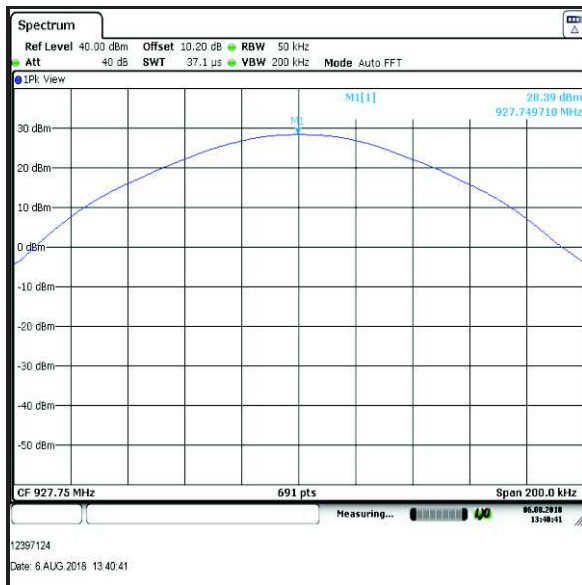

Top Channel

5.2.6. Transmitter Conducted Emissions

Test Summary:

Test Engineer:	Segun I. Adeniji	Test Date:	26 September 2018
Test Sample Serial Number:	GOK4485954		
Test Site Identification	SR 9		

FCC Reference:	Part 15.247(d)
Test Method Used:	ANSI C63.10 Sections 6.7 and 7.8.8
Frequency Range	30 MHz to 1 GHz

Environmental Conditions:

Temperature (°C):	24.5
Relative Humidity (%):	40

Notes:

1. The final measured value, for the given emission, in the table below incorporates the calibrated antenna factor and cable loss.

Test setup:

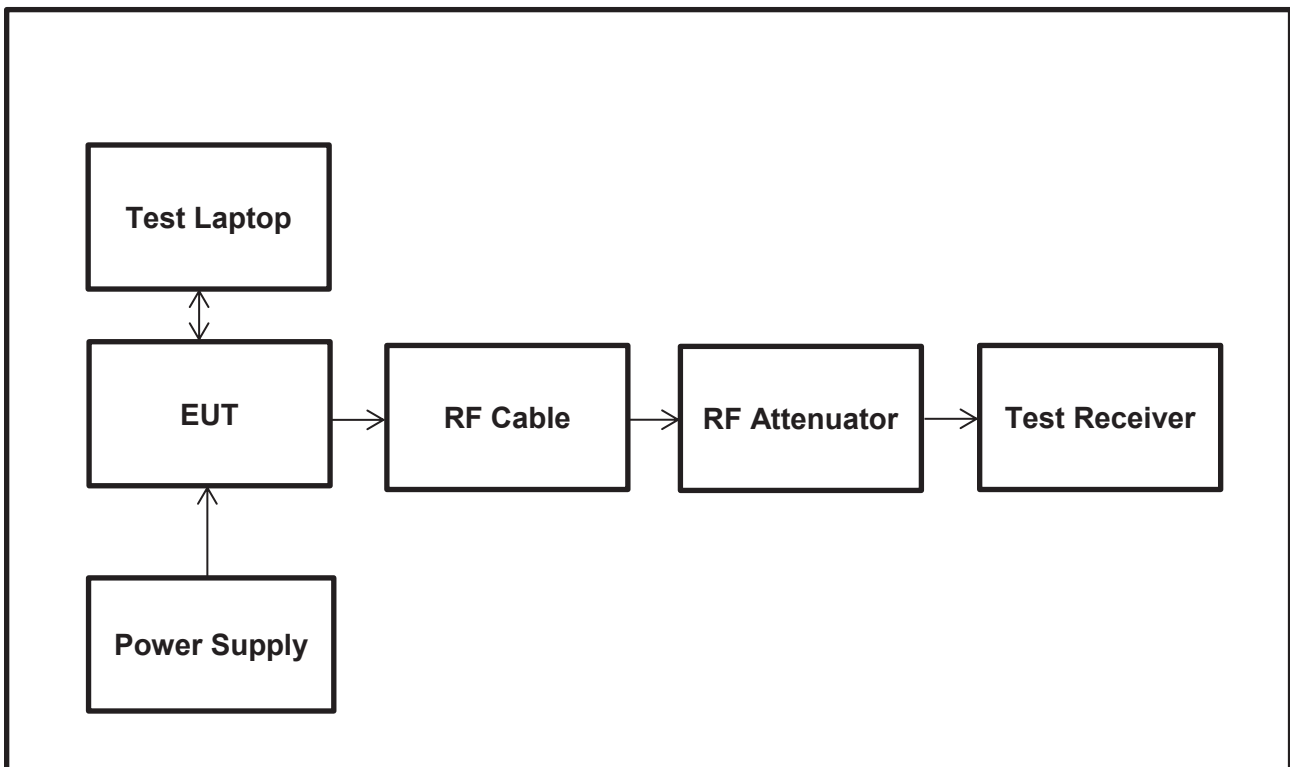

Transmitter Conducted Emissions (continued)

Results: Peak / Bottom Channel / WIRA-40-linear-FCC

Frequency (MHz)	Level (dBµV/m)	Antenna Gain (dBi)	Corrected Level (dBuV/m)	Limit (dBµV/m)	Margin (dB)	Result
No critical Spurious found						

Results: Peak / Middle Channel / WIRA-40-linear-FCC

Frequency (MHz)	Level (dBµV/m)	Antenna Gain (dBi)	Corrected Level (dBuV/m)	Limit (dBµV/m)	Margin (dB)	Result
No critical Spurious found						

Results: Peak / Top Channel / WIRA-40-linear-FCC

Frequency (MHz)	Level (dBµV/m)	Antenna Gain (dBi)	Corrected Level (dBuV/m)	Limit (dBµV/m)	Margin (dB)	Result
No critical Spurious found						

Results: Peak / Hopping Mode / WIRA-40-linear-FCC

Frequency (MHz)	Level (dBµV/m)	Antenna Gain (dBi)	Corrected Level (dBuV/m)	Limit (dBµV/m)	Margin (dB)	Result
No critical Spurious found						

Results: Peak / Bottom Channel / WIRA-30-circular-FCC

Frequency (MHz)	Level (dB μ V/m)	Antenna Gain (dBi)	Corrected Level (dBuV/m)	Limit (dB μ V/m)	Margin (dB)	Result
No critical Spurious found						

Results: Peak / Middle Channel / WIRA-30-circular-FCC

Frequency (MHz)	Level (dB μ V/m)	Antenna Gain (dBi)	Corrected Level (dBuV/m)	Limit (dB μ V/m)	Margin (dB)	Result
No critical Spurious found						

Results: Peak / Top Channel / WIRA-30-circular-FCC

Frequency (MHz)	Level (dB μ V/m)	Antenna Gain (dBi)	Corrected Level (dBuV/m)	Limit (dB μ V/m)	Margin (dB)	Result
No critical Spurious found						

Results: Peak / Hopping Mode / WIRA-30-circular-FCC

Frequency (MHz)	Level (dB μ V/m)	Antenna Gain (dBi)	Corrected Level (dBuV/m)	Limit (dB μ V/m)	Margin (dB)	Result
No critical Spurious found						

Results: Peak / Bottom Channel / WIRA-70-KRAI-FCC

Frequency (MHz)	Level (dBµV/m)	Antenna Gain (dBi)	Corrected Level (dBuV/m)	Limit (dBµV/m)	Margin (dB)	Result
No critical Spurious found						

Results: Peak / Middle Channel / WIRA-70-KRAI-FCC

Frequency (MHz)	Level (dBµV/m)	Antenna Gain (dBi)	Corrected Level (dBuV/m)	Limit (dBµV/m)	Margin (dB)	Result
No critical Spurious found						

Results: Peak / Top Channel / WIRA-70-KRAI-FCC

Frequency (MHz)	Level (dBµV/m)	Antenna Gain (dBi)	Corrected Level (dBuV/m)	Limit (dBµV/m)	Margin (dB)	Result
No critical Spurious found						

Results: Peak / Hopping Mode / WIRA-70-KRAI-FCC

Frequency (MHz)	Level (dBµV/m)	Antenna Gain (dBi)	Corrected Level (dBuV/m)	Limit (dBµV/m)	Margin (dB)	Result
No critical Spurious found						

Results: Peak / Bottom Channel / SSMH-30-30-ETSI-FCC

Frequency (MHz)	Level (dBµV/m)	Antenna Gain (dBi)	Corrected Level (dBuV/m)	Limit (dBµV/m)	Margin (dB)	Result
No critical Spurious found						

Results: Peak / Middle Channel / SSMH-30-30-ETSI-FCC

Frequency (MHz)	Level (dBµV/m)	Antenna Gain (dBi)	Corrected Level (dBuV/m)	Limit (dBµV/m)	Margin (dB)	Result
No critical Spurious found						

Results: Peak / Top Channel / SSMH-30-30-ETSI-FCC

Frequency (MHz)	Level (dBµV/m)	Antenna Gain (dBi)	Corrected Level (dBuV/m)	Limit (dBµV/m)	Margin (dB)	Result
No critical Spurious found						

Results: Peak / Hopping Mode / SSMH-30-30-ETSI-FCC

Frequency (MHz)	Level (dBµV/m)	Antenna Gain (dBi)	Corrected Level (dBuV/m)	Limit (dBµV/m)	Margin (dB)	Result
No critical Spurious found						

Transmitter Conducted Emissions / WIRA-40-linear-FCC & WIRA-30-circular-FCC

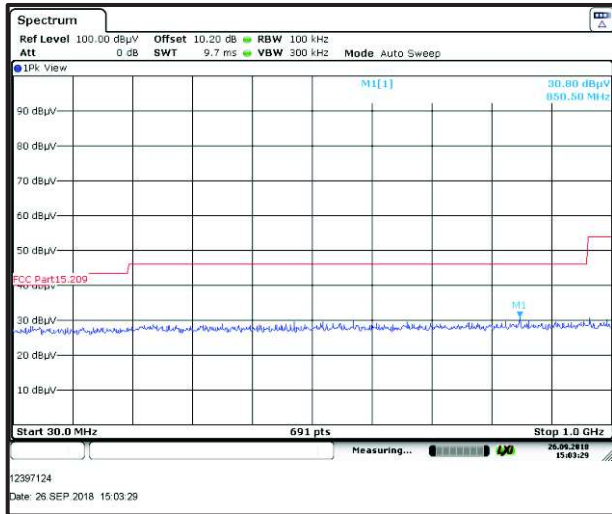

Bottom Channel

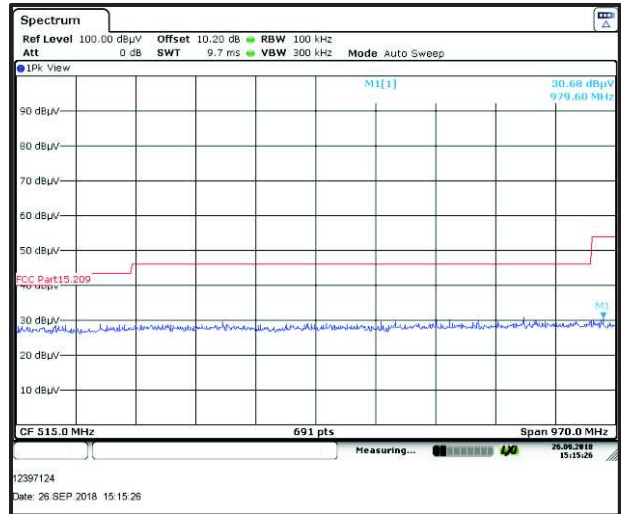

Middle Channel

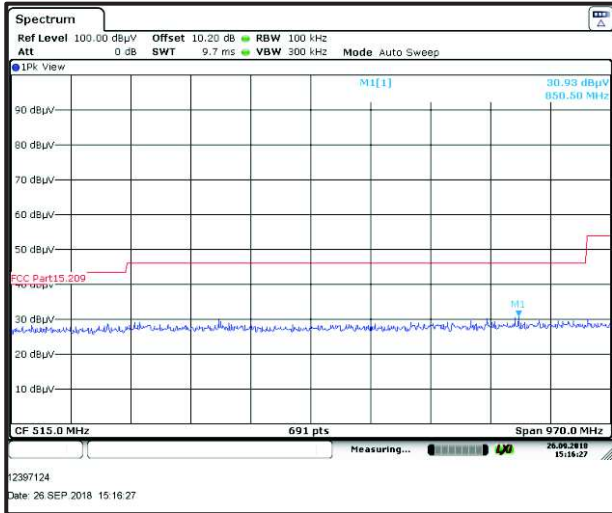

Top Channel

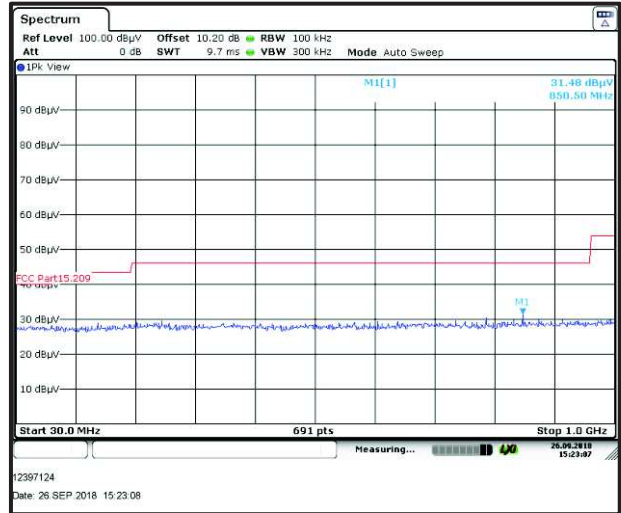

Hopping Mode

Transmitter Conducted Emissions / WIRA-70-KRAI-FCC & SMSH-30-30-ETSI-FCC

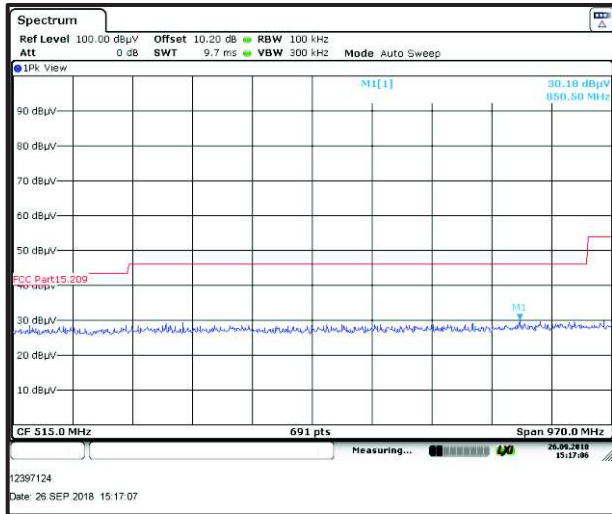

Bottom Channel

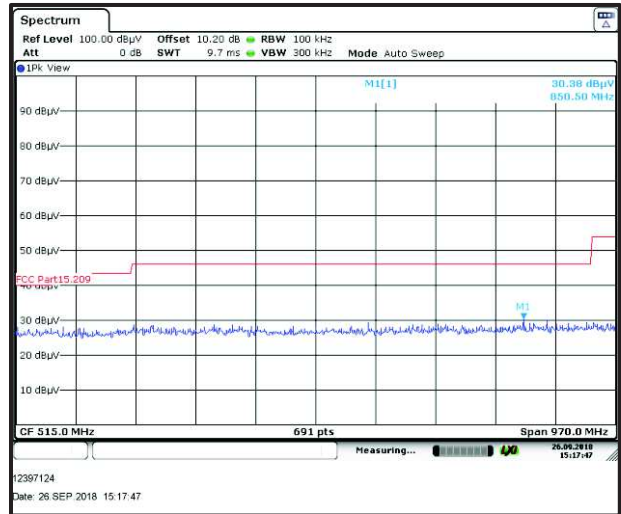

Middle Channel

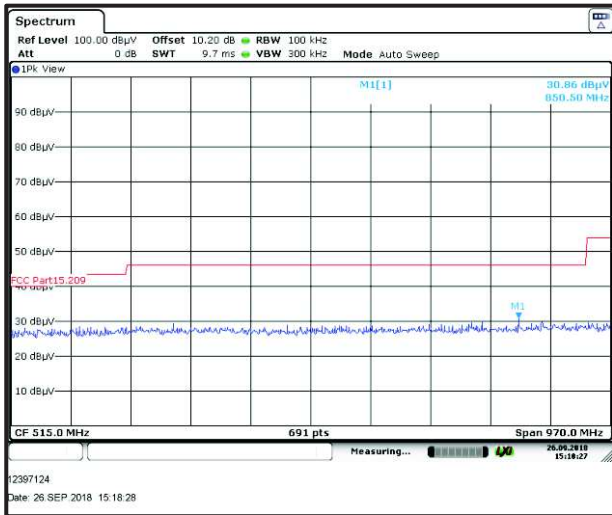

Top Channel

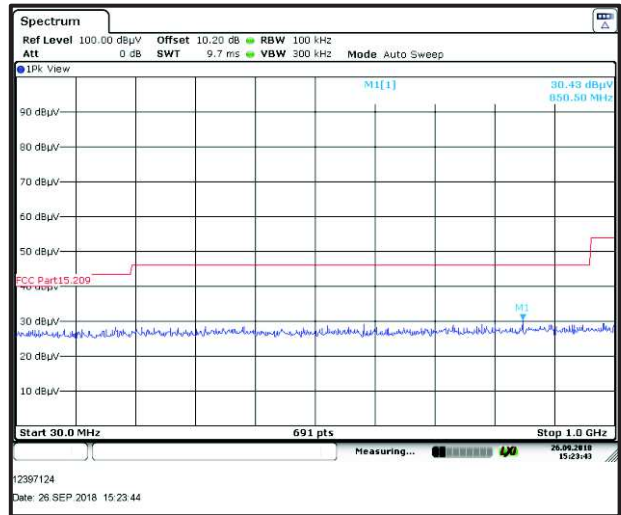

Hopping Mode

Result: **Pass**

Test Summary:

Test Engineer:	Segun I. Adeniji	Test Date:	26 September 2018
Test Sample Serial Number:	GOK4485954		
Test Site Identification	SR 9		

FCC Reference:	Part 15.247(d)
Test Method Used:	ANSI C63.10 Sections 6.7 and 7.8.8
Frequency Range	1 GHz to 10 GHz

Environmental Conditions:

Temperature (°C):	23.3
Relative Humidity (%):	40

Notes:

1. The final measured value, for the given emission, in the table below incorporates the calibrated antenna factor and cable loss.
2. 20 dBc Limit* from worst case Antenna has been selected to show compliance to all other antenna types.
3. SMSH-30-30-ETSI-FCC & WIRA-70-KRAI-FCC worst case 20 dBc limit: 87.15 dB μ V/m
4. WIRA-40-linear-FCC & WIRA-30-circular-FCC worst case 20 dBc limit: 91.24 dB μ V/m

Test setup:

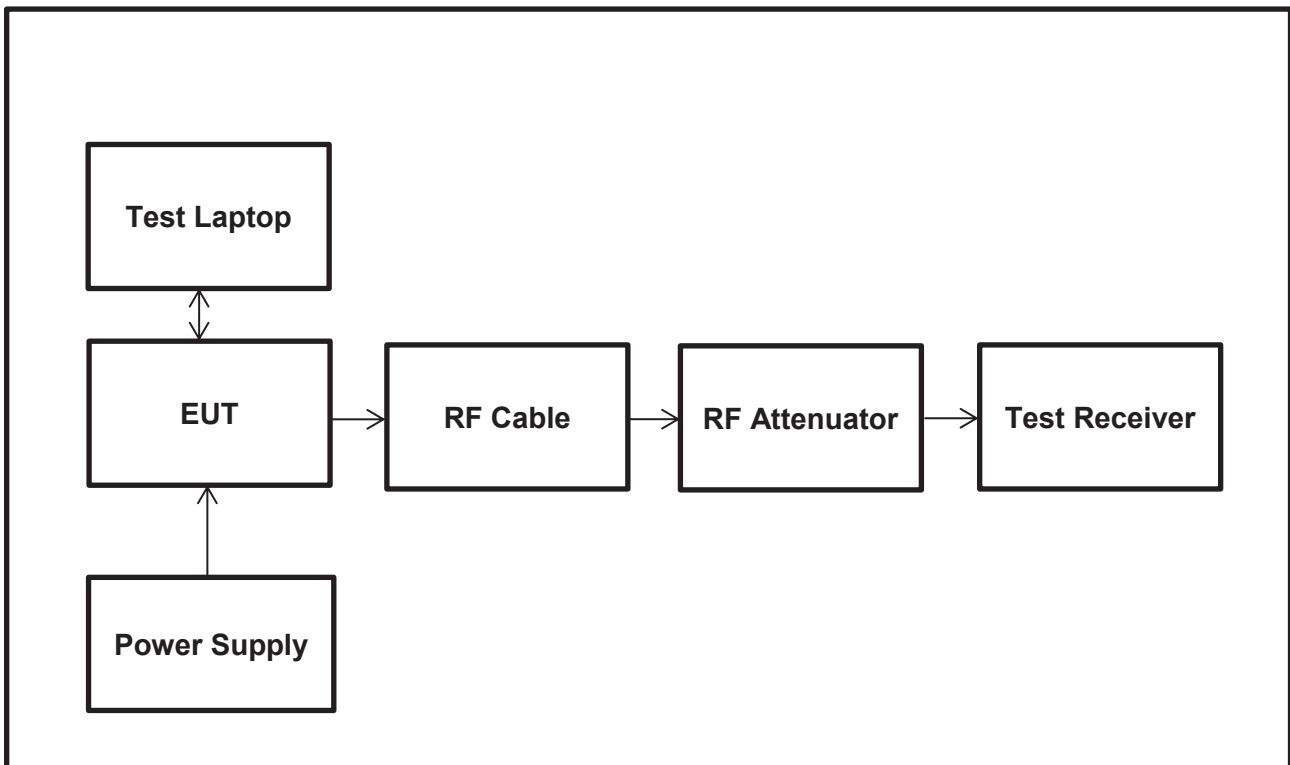

Transmitter Conducted Emissions (continued)**Results: Peak / Bottom Channel / WIRA-70-KRAI-FCC**

Frequency (MHz)	Level (dB μ V/m)	Antenna Gain (dBi)	Corrected EIRP Level (dBuV/m)	20 dBc Limit* (dB μ V/m)	Margin (dB)	Result
1801.0	41.36	7.5	48.86	87.15	38.29	Complied

Results: Peak / Middle Channel / WIRA-70-KRAI-FCC

Frequency (MHz)	Level (dB μ V/m)	Antenna Gain (dBi)	Corrected EIRP Level (dBuV/m)	20 dBc Limit* (dB μ V/m)	Margin (dB)	Result
1827.0	41.53	7.5	49.03	87.15	38.12	Complied

Results: Peak / Top Channel / WIRA-70-KRAI-FCC

Frequency (MHz)	Level (dB μ V/m)	Antenna Gain (dBi)	Corrected EIRP Level (dBuV/m)	20 dBc Limit* (dB μ V/m)	Margin (dB)	Result
1853.0	42.30	7.5	49.8	87.15	37.35	Complied

Results: Peak / Hopping Mode / WIRA-70-KRAI-FCC

Frequency (MHz)	Level (dB μ V/m)	Antenna Gain (dBi)	Corrected EIRP Level (dBuV/m)	20 dBc Limit* (dB μ V/m)	Margin (dB)	Result
1853.0	43.46	7.5	50.96	87.15	36.19	Complied

Results: Peak / Bottom Channel / SSMH-30-30-ETSI-FCC

Frequency (MHz)	Level (dB μ V/m)	Antenna Gain (dBi)	Corrected EIRP Level (dBuV/m)	20 dBc Limit* (dB μ V/m)	Margin (dB)	Result
1801.0	41.36	-10	31.36	87.15	55.79	Complied

Results: Peak / Middle Channel / SSMH-30-30-ETSI-FCC

Frequency (MHz)	Level (dB μ V/m)	Antenna Gain (dBi)	Corrected EIRP Level (dBuV/m)	20 dBc Limit* (dB μ V/m)	Margin (dB)	Result
1827.0	41.53	-10	31.53	87.15	55.62	Complied

Results: Peak / Top Channel / SSMH-30-30-ETSI-FCC

Frequency (MHz)	Level (dB μ V/m)	Antenna Gain (dBi)	Corrected EIRP Level (dBuV/m)	20 dBc Limit* (dB μ V/m)	Margin (dB)	Result
1853.0	42.30	-10	32.30	87.15	54.85	Complied

Results: Peak / Hopping Mode / SSMH-30-30-ETSI-FCC

Frequency (MHz)	Level (dB μ V/m)	Antenna Gain (dBi)	Corrected EIRP Level (dBuV/m)	20 dBc Limit* (dB μ V/m)	Margin (dB)	Result
1853.0	43.46	-10	33.46	87.15	36.19	Complied

Results: Peak / Bottom Channel / WIRA-40-linear-FCC

Frequency (MHz)	Level (dB μ V/m)	Antenna Gain (dBi)	Corrected EIRP Level (dBuV/m)	20 dBc Limit* (dB μ V/m)	Margin (dB)	Result
1801.0	35.32	10.0	45.32	91.24	45.92	Complied

Results: Peak / Middle Channel / WIRA-40-linear-FCC

Frequency (MHz)	Level (dB μ V/m)	Antenna Gain (dBi)	Corrected EIRP Level (dBuV/m)	20 dBc Limit* (dB μ V/m)	Margin (dB)	Result
1827.0	36.15	10.0	46.15	91.24	45.09	Complied

Results: Peak / Top Channel / WIRA-40-linear-FCC

Frequency (MHz)	Level (dB μ V/m)	Antenna Gain (dBi)	Corrected EIRP Level (dBuV/m)	20 dBc Limit* (dB μ V/m)	Margin (dB)	Result
1853.0	35.59	10.0	45.59	91.24	45.65	Complied

Results: Peak / Hopping Mode / WIRA-40-linear-FCC

Frequency (MHz)	Level (dB μ V/m)	Antenna Gain (dBi)	Corrected EIRP Level (dBuV/m)	20 dBc Limit* (dB μ V/m)	Margin (dB)	Result
1853.0	36.41	10.0	46.41	91.24	44.83	Complied

Results: Peak / Bottom Channel / WIRA-30-circular-FCC**Results: Peak / Bottom Channel / WIRA-40-linear-FCC**

Frequency (MHz)	Level (dB μ V/m)	Antenna Gain (dBi)	Corrected EIRP Level (dBuV/m)	20 dBc Limit* (dB μ V/m)	Margin (dB)	Result
1801.0	35.32	8.0	43.32	91.24	47.92	Complied

Results: Peak / Middle Channel / WIRA-40-linear-FCC

Frequency (MHz)	Level (dB μ V/m)	Antenna Gain (dBi)	Corrected EIRP Level (dBuV/m)	20 dBc Limit* (dB μ V/m)	Margin (dB)	Result
1827.0	36.15	8.0	44.15	91.24	47.09	Complied

Results: Peak / Top Channel / WIRA-40-linear-FCC

Frequency (MHz)	Level (dB μ V/m)	Antenna Gain (dBi)	Corrected EIRP Level (dBuV/m)	20 dBc Limit* (dB μ V/m)	Margin (dB)	Result
1853.0	35.59	8.0	43.59	91.24	47.65	Complied

Results: Peak / Hopping Mode / WIRA-40-linear-FCC

Frequency (MHz)	Level (dB μ V/m)	Antenna Gain (dBi)	Corrected EIRP Level (dBuV/m)	20 dBc Limit* (dB μ V/m)	Margin (dB)	Result
1853.0	36.41	8.0	44.41	91.24	46.83	Complied

Transmitter Conducted Emissions / WIRA-70-KRAI-FCC & SMSH-30-30-ETSI-FCC

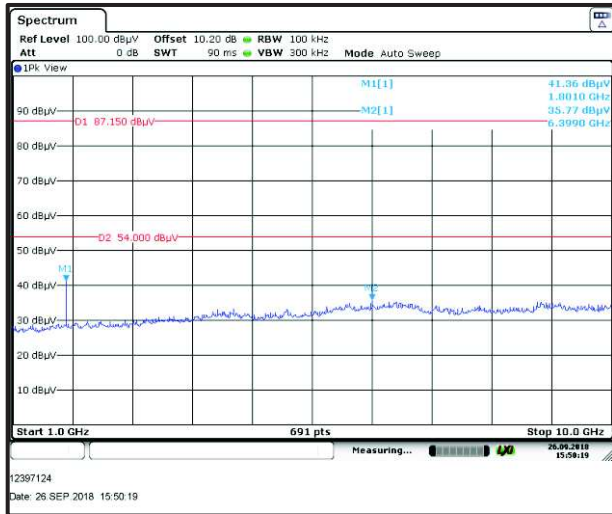

Bottom Channel

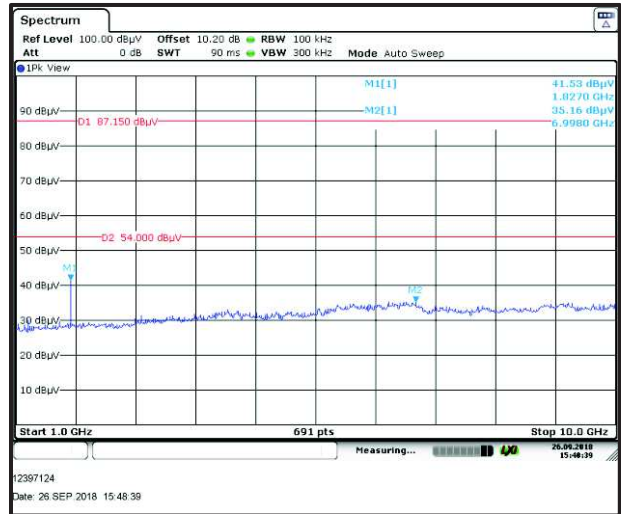

Middle Channel

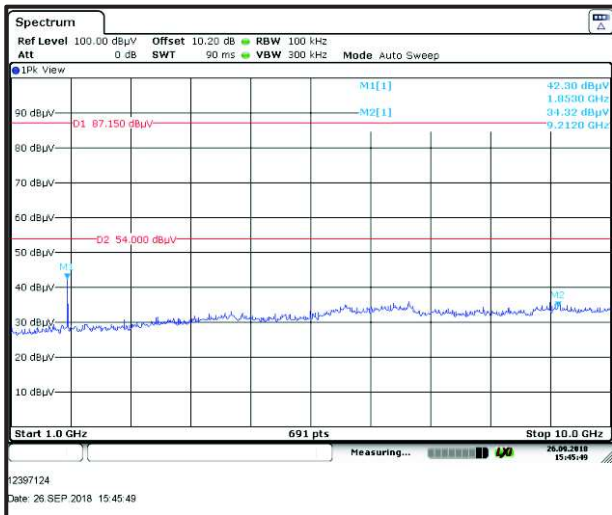

Top Channel

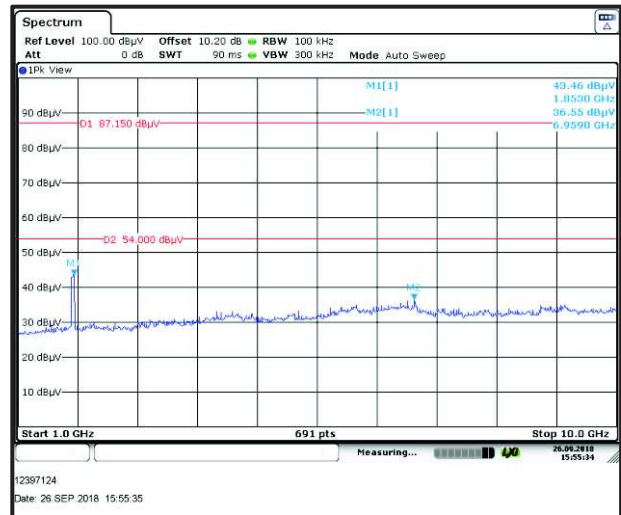

Hopping Mode

Result: Pass

Transmitter Conducted Emissions / WIRA-40-linear-FCC AND WIRA-30-circular-FCC

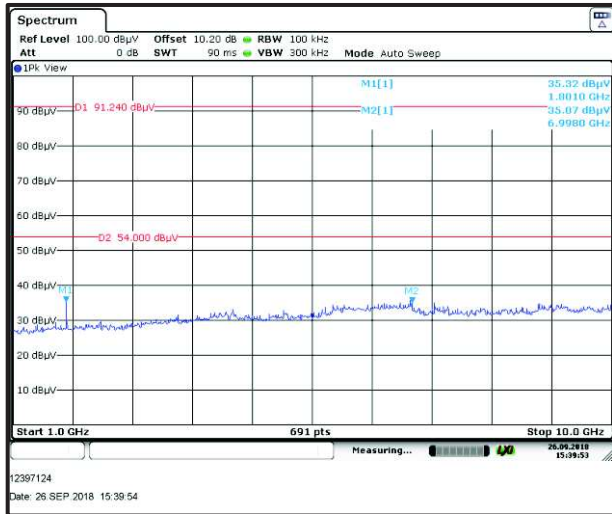

Bottom Channel

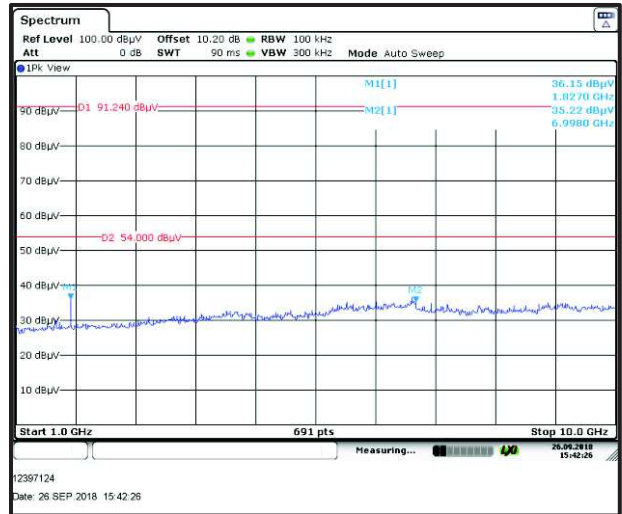

Middle Channel

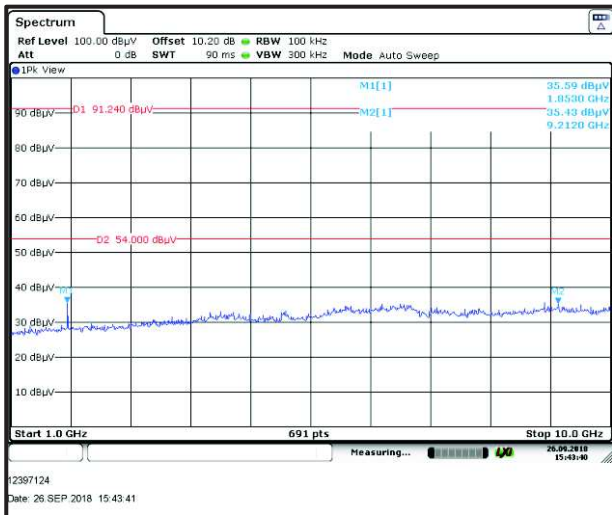

Top Channel

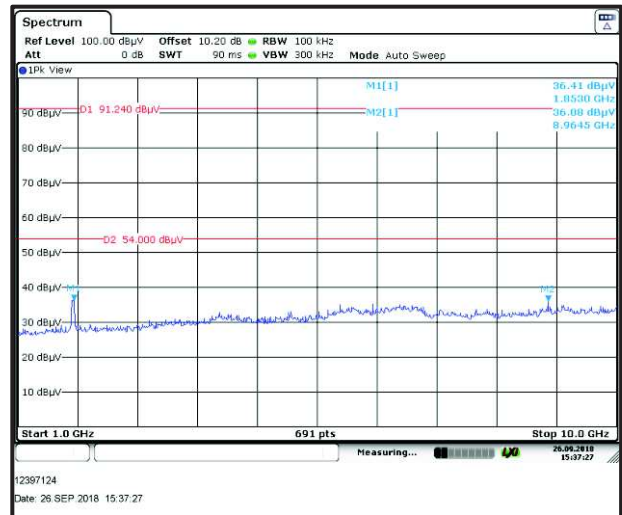

Hopping Mode

Result: **Pass**

5.2.7. Transmitter Band Edge Radiated Emissions

Test Summary:

Test Engineer:	Abdoufataou Salifou	Test Date:	12 & 13 September 2018
Test Sample Serial Number:	GOK4485954		
Test Site Identification	SR 1/2		

FCC Reference:	Parts 15.247(d) & 15.209(a)
Test Method Used:	ANSI C63.10 Section 6.10.4, 6.10.5 & KDB 558074 Section 11

Environmental Conditions:

Temperature (°C):	24
Relative Humidity (%):	46

Note(s):

1. The final measured value, for the given emission, in the table below incorporates the calibrated antenna factor and cable loss.
2. The plots shown on the following page were performed using a peak detector.
3. For the test made with the EUT in hopping mode, the both Band Edge are insert in one plot.

Test Setup:

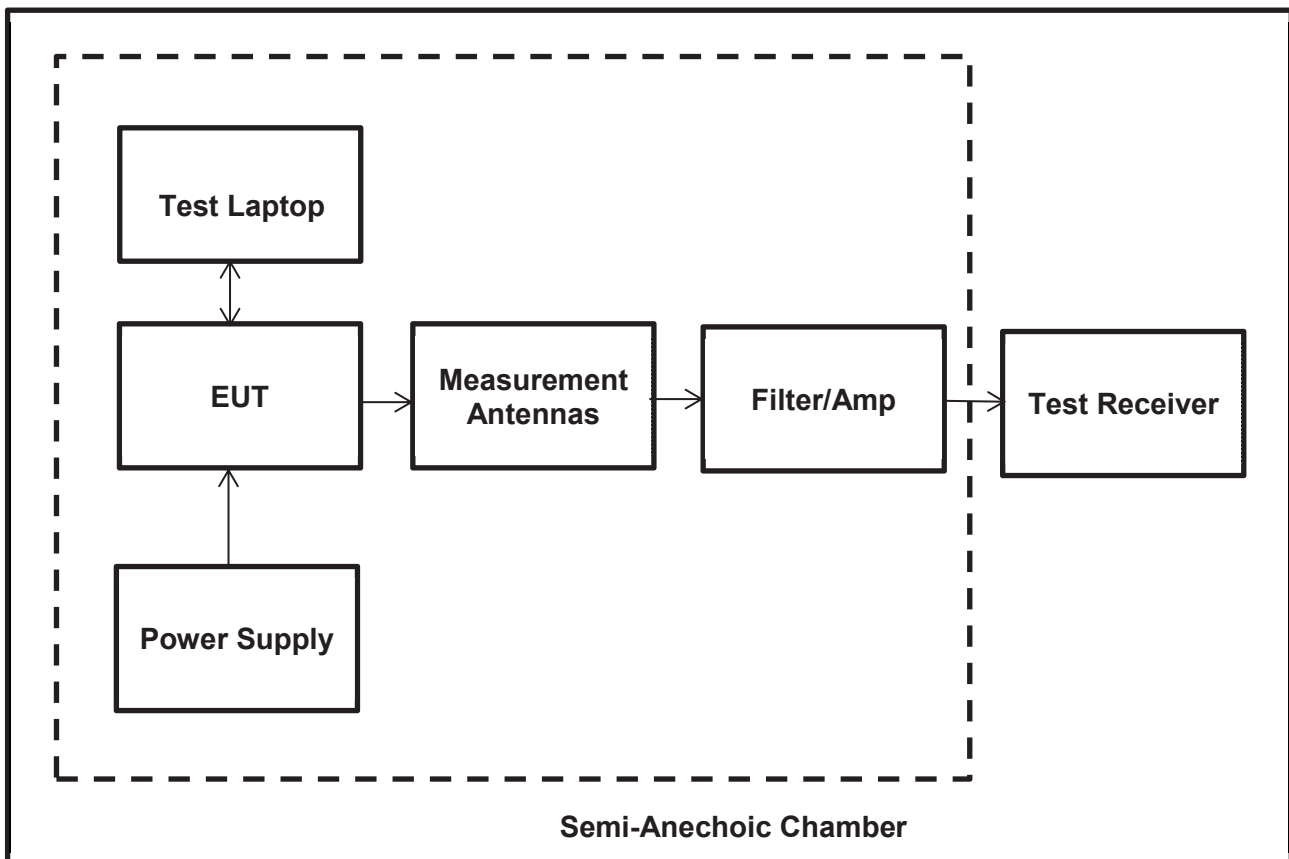

Transmitter Band Edge Radiated Emissions (continued)**Results: Bottom/ WIRA-70-KRAI-FCC / (Polarization: HP)**

Frequency (MHz)	Antenna Polarization	Level (dB μ V/m)	20 dBc Limit (dB μ V/m)	Margin (dB)	Result
899.98	Vertical	66.49	101.99	35.50	Complied
902.00	Vertical	63.69	101.99	38.30	Complied

Results: Top / WIRA-70-KRAI-FCC / (Polarization: HP)

Frequency (MHz)	Antenna Polarization	Level (dB μ V/m)	20 dBc Limit (dB μ V/m)	Margin (dB)	Result
928.00	Vertical	62.32	101.71	39.39	Complied
928.20	Vertical	63.80	101.71	37.91	Complied

Results: Bottom/ Hopping / WIRA-70-KRAI-FCC / (Polarization: HP)

Frequency (MHz)	Antenna Polarization	Level (dB μ V/m)	20 dBc Limit (dB μ V/m)	Margin (dB)	Result
902.00	Vertical	99.33	102.07	2.74	Complied

Results: Top/ Hopping / WIRA-70-KRAI-FCC / (Polarization: HP)

Frequency (MHz)	Antenna Polarization	Level (dB μ V/m)	20 dBc Limit (dB μ V/m)	Margin (dB)	Result
928.00	Vertical	93.10	102.07	8.97	Complied

Result: Pass

Transmitter Band Edge Radiated Emissions / WIRA-70-KRAI-FCC / (Polarization: HP)

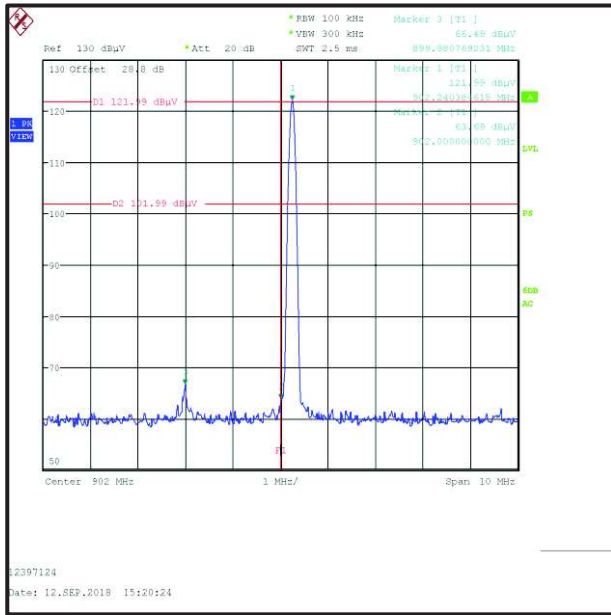

Lower Band Edge Peak Measurement

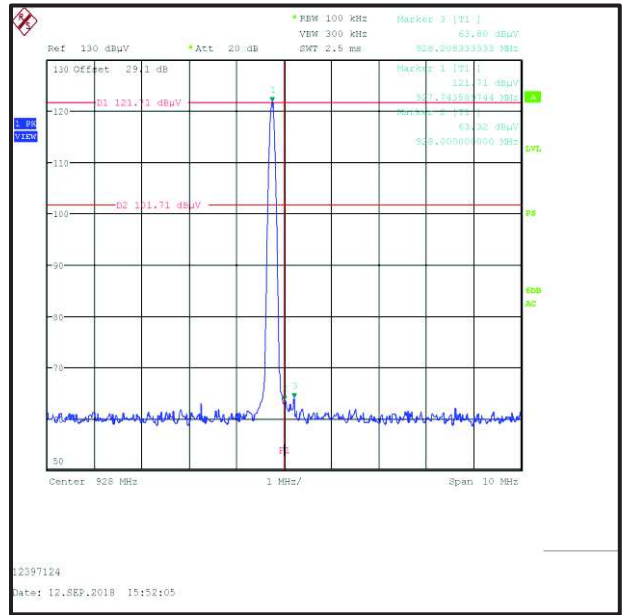

Upper Band Edge Peak Measurement

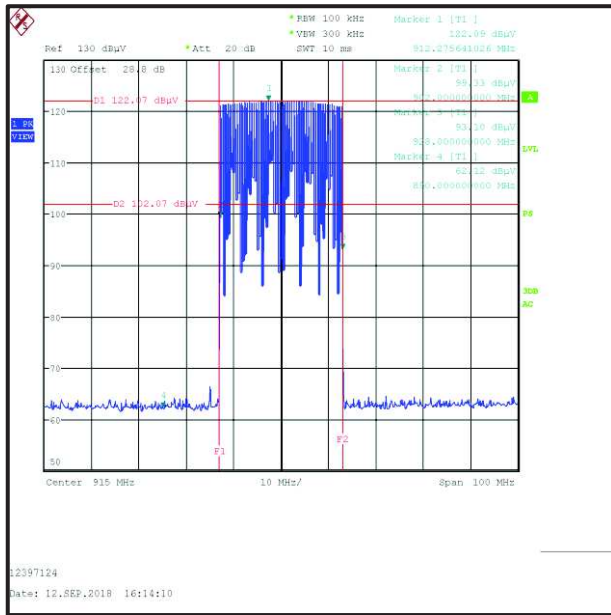

Lower and Upper Band Edge measurement Hopping mode

Results: Bottom/ WIRA-70-KRAI-FCC / (Polarization: VP)

Frequency (MHz)	Antenna Polarization	Level (dB μ V/m)	20 dBc Limit (dB μ V/m)	Margin (dB)	Result
899.96	Vertical	66.49	106.99	40.50	Complied
902.00	Vertical	68.77	106.99	38.22	Complied

Results: Top / WIRA-70-KRAI-FCC / (Polarization: VP)

Frequency (MHz)	Antenna Polarization	Level (dB μ V/m)	20 dBc Limit (dB μ V/m)	Margin (dB)	Result
928.00	Vertical	67.25	106.09	38.84	Complied
929.76	Vertical	68.70	106.09	37.39	Complied

Results: Bottom/ Hopping / WIRA-70-KRAI-FCC / (Polarization: VP)

Frequency (MHz)	Antenna Polarization	Level (dB μ V/m)	20 dBc Limit (dB μ V/m)	Margin (dB)	Result
902.00	Vertical	90.13	92.83	2.70	Complied

Results: Top/ Hopping / WIRA-70-KRAI-FCC / (Polarization: VP)

Frequency (MHz)	Antenna Polarization	Level (dB μ V/m)	20 dBc Limit (dB μ V/m)	Margin (dB)	Result
928.00	Vertical	79.41	92.83	13.42	Complied

Result: Pass

Transmitter Band Edge Radiated Emissions / (Polarization: VP)

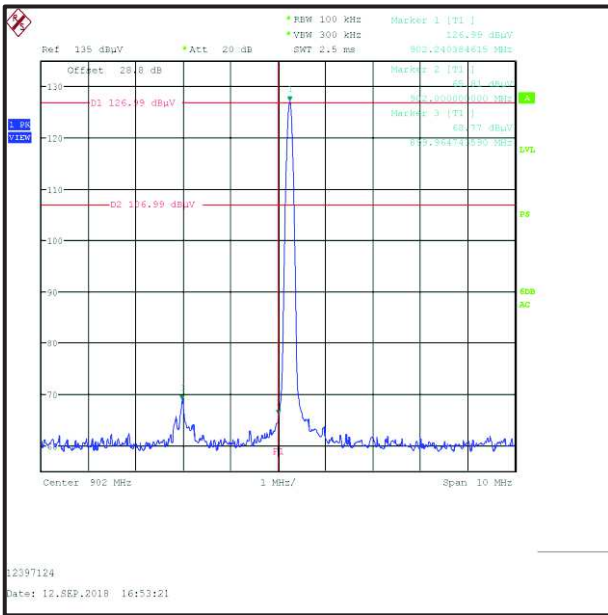

Lower Band Edge Peak Measurement

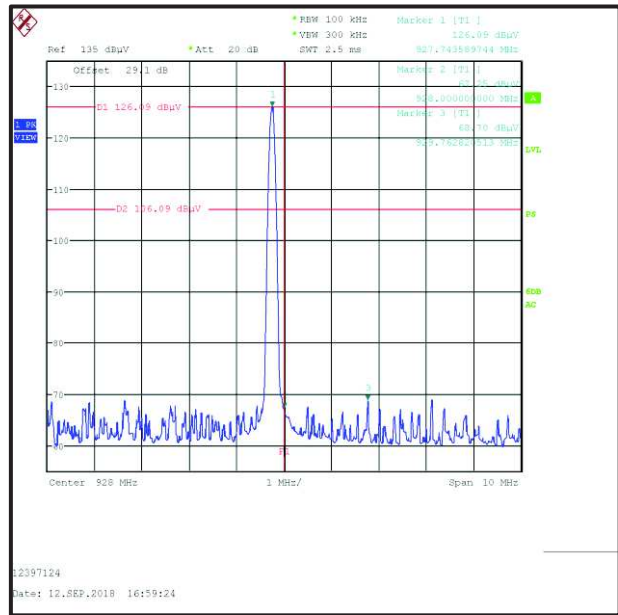

Upper Band Edge Peak Measurement

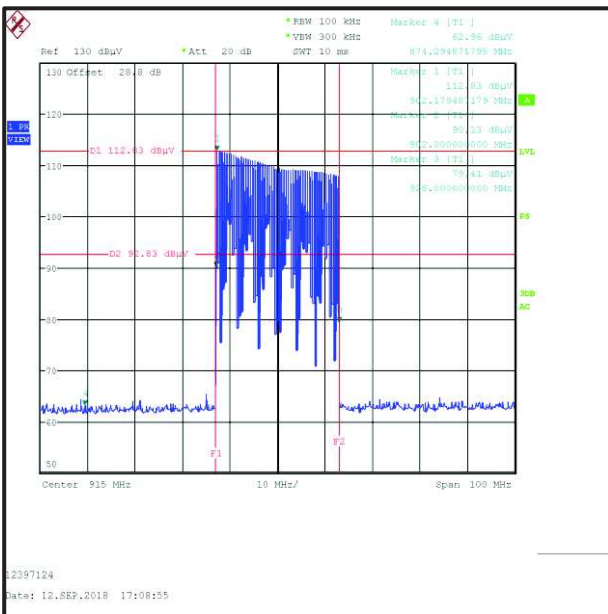

Lower and Upper Band Edge measurement Hopping mode

Results: Bottom/ WIRA-70-KRAI-FCC / (Polarization: RHCP)

Frequency (MHz)	Antenna Polarization	Level (dB μ V/m)	20 dBc Limit (dB μ V/m)	Margin (dB)	Result
899.96	Horizontal	68.16	106.12	37.96	Complied
902.00	Horizontal	64.24	106.12	41.88	Complied

Results: Top / WIRA-70-KRAI-FCC / (Polarization: RHCP)

Frequency (MHz)	Antenna Polarization	Level (dB μ V/m)	20 dBc Limit (dB μ V/m)	Margin (dB)	Result
928.00	Horizontal	65.07	105.56	40.49	Complied
930.22	Horizontal	62.48	105.56	43.08	Complied

Results: Bottom/ Hopping / WIRA-70-KRAI-FCC / (Polarization: RHCP)

Frequency (MHz)	Antenna Polarization	Level (dB μ V/m)	20 dBc Limit (dB μ V/m)	Margin (dB)	Result
902.00	Horizontal	105.99	108.64	2.65	Complied
899.93	Horizontal	70.31	108.64	38.33	Complied

Results: Top/ Hopping / WIRA-70-KRAI-FCC / (Polarization: RHCP)

Frequency (MHz)	Antenna Polarization	Level (dB μ V/m)	20 dBc Limit (dB μ V/m)	Margin (dB)	Result
928.00	Horizontal	98.96	108.64	9.68	Complied

Result: Pass

Transmitter Band Edge Radiated Emissions / (Polarization: RHCP)

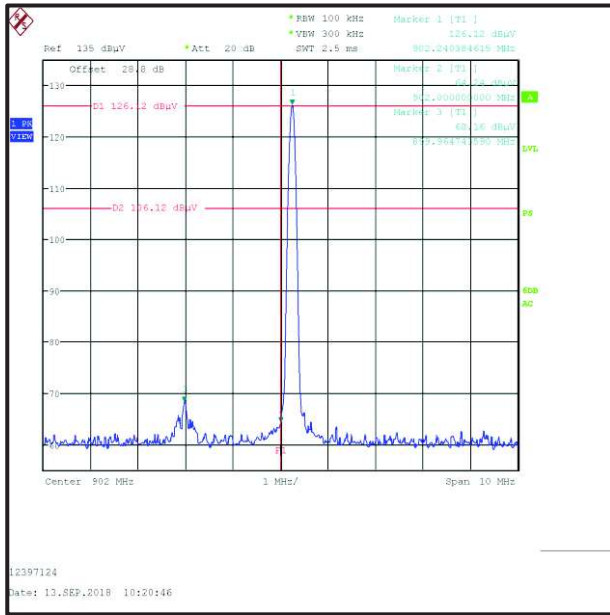

Lower Band Edge Peak Measurement

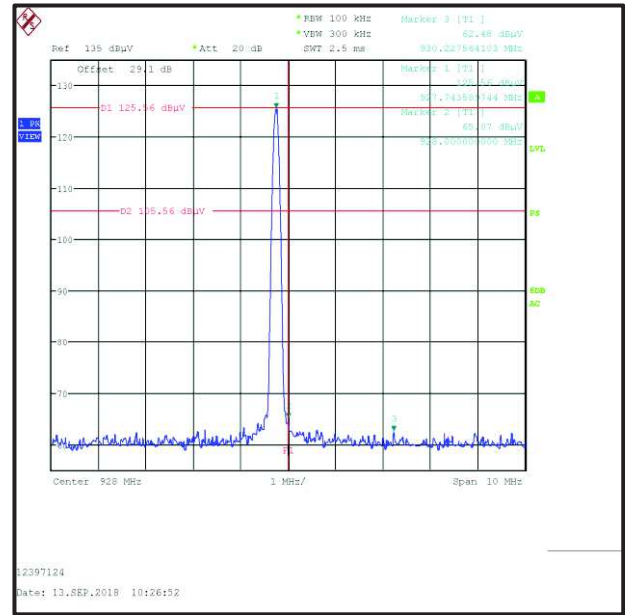

Upper Band Edge Peak Measurement

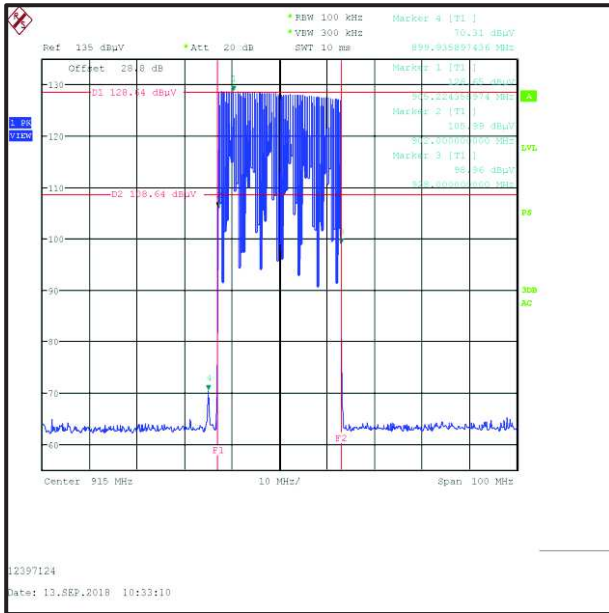

Lower and Upper Band Edge measurement Hopping mode

Results: Bottom/ WIRA-70-KRAI-FCC / (Polarization: LHCP)

Frequency (MHz)	Antenna Polarization	Level (dBµV/m)	20 dBc Limit (dBµV/m)	Margin (dB)	Result
899.96	Horizontal	66.62	106.59	39.97	Complied
902.00	Horizontal	68.61	106.59	37.98	Complied

Results: Top / WIRA-70-KRAI-FCC / (Polarization: LHCP)

Frequency (MHz)	Antenna Polarization	Level (dBµV/m)	20 dBc Limit (dBµV/m)	Margin (dB)	Result
928.00	Horizontal	65.18	105.76	40.58	Complied
930.09	Horizontal	63.44	105.76	42.32	Complied

Results: Bottom/ Hopping / WIRA-70-KRAI-FCC / (Polarization: LHCP)

Frequency (MHz)	Antenna Polarization	Level (dBµV/m)	20 dBc Limit (dBµV/m)	Margin (dB)	Result
902.00	Horizontal	83.58	106.73	23.15	Complied
899.93	Horizontal	81.46	106.73	25.27	Complied

Results: Top/ Hopping / WIRA-70-KRAI-FCC / (Polarization: LHCP)

Frequency (MHz)	Antenna Polarization	Level (dBµV/m)	20 dBc Limit (dBµV/m)	Margin (dB)	Result
928.00	Horizontal	81.46	106.73	25.27	Complied

Result: Pass

Transmitter Band Edge Radiated Emissions / (Polarization: LHCP)

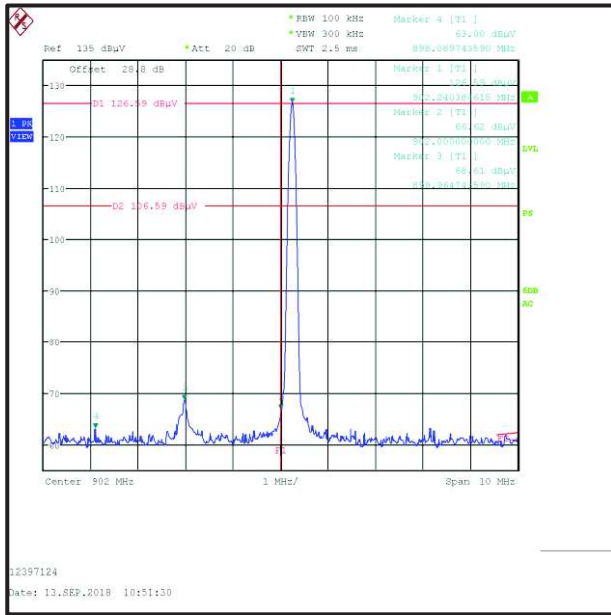

Lower Band Edge Peak Measurement

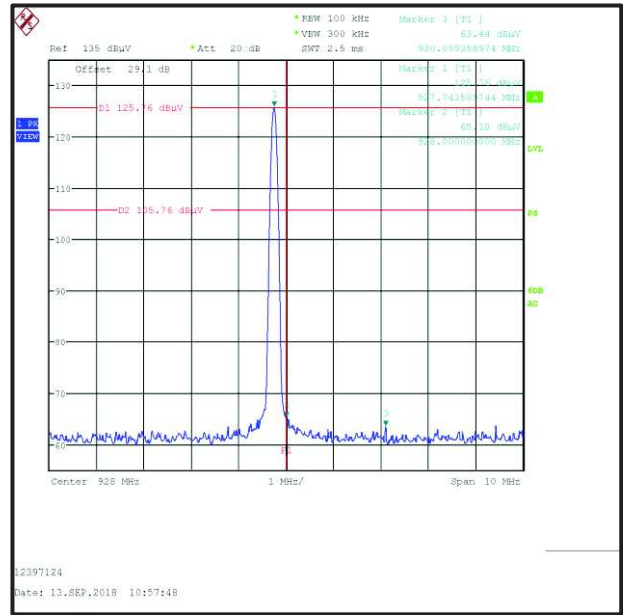

Upper Band Edge Peak Measurement

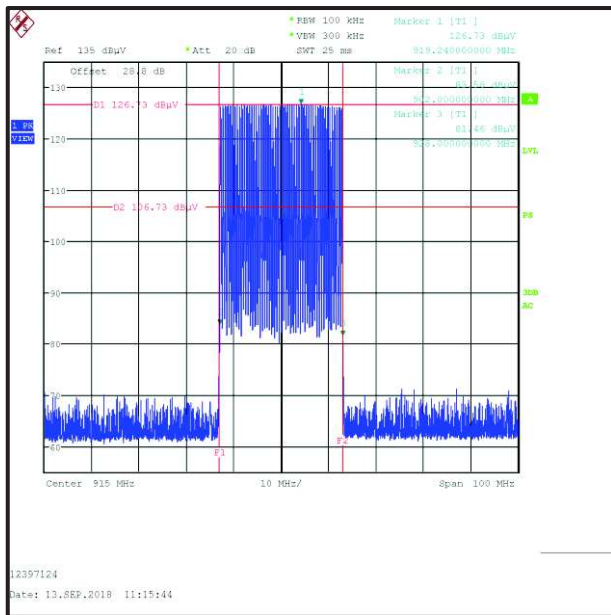

Lower and Upper Band Edge measurement Hopping mode

Results: Bottom/ SMSH-30-30-ETSI-FCC

Frequency (MHz)	Antenna Polarization	Level (dB μ V/m)	20 dBc Limit (dB μ V/m)	Margin (dB)	Result
897.65	Horizontal	60.71	89.88	29.17	Complied
902.00	Horizontal	59.02	89.88	30.86	Complied

Results: Top / SMSH-30-30-ETSI-FCC

Frequency (MHz)	Antenna Polarization	Level (dB μ V/m)	20 dBc Limit (dB μ V/m)	Margin (dB)	Result
928.00	Horizontal	61.17	87.15	25.98	Complied
931.02	Horizontal	63.09	87.15	24.06	Complied

Results: Bottom/ Hopping / SMSH-30-30-ETSI-FCC

Frequency (MHz)	Antenna Polarization	Level (dB μ V/m)	20 dBc Limit (dB μ V/m)	Margin (dB)	Result
902.00	Horizontal	85.57	88.78	3.21	Complied

Results: Top/ Hopping / SMSH-30-30-ETSI-FCC

Frequency (MHz)	Antenna Polarization	Level (dB μ V/m)	20 dBc Limit (dB μ V/m)	Margin (dB)	Result
928.00	Horizontal	81.17	88.78	7.61	Complied

Result: Pass

Transmitter Band Edge Radiated Emissions / SSMH-30-30-ETSI-FCC

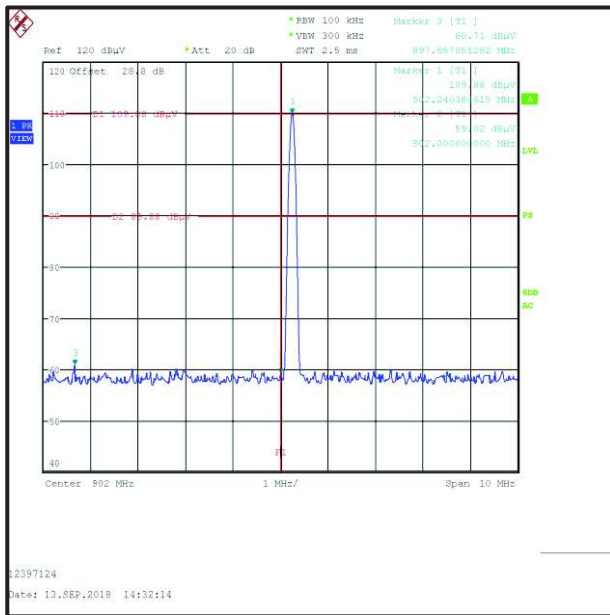

Lower Band Edge Peak Measurement

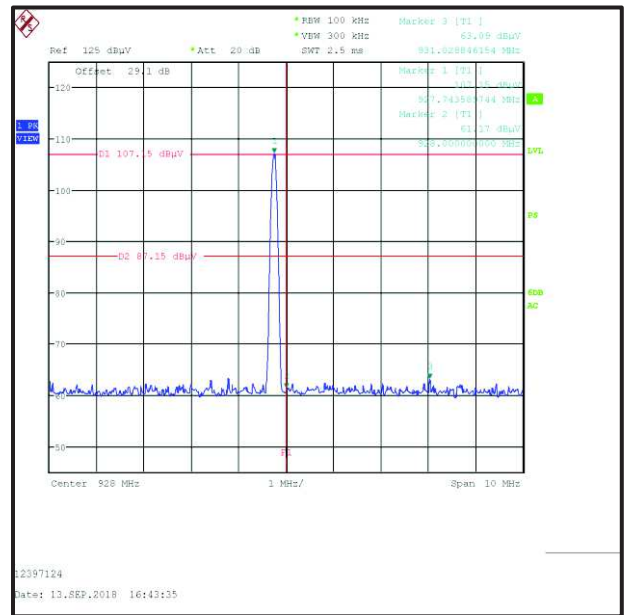

Upper Band Edge Peak Measurement

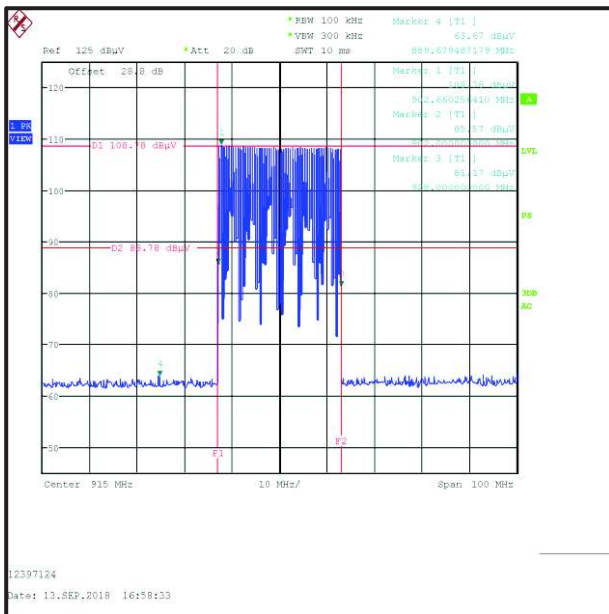

Lower and Upper Band Edge measurement Hopping mode

Results: Bottom/ WIRA-40-linear-FCC

Frequency (MHz)	Antenna Polarization	Level (dB μ V/m)	20 dBc Limit (dB μ V/m)	Margin (dB)	Result
899.98	Vertical	61.76	91.24	29.48	Complied
902.00	Vertical	59.68	91.24	31.56	Complied

Results: Top / WIRA-40-linear-FCC

Frequency (MHz)	Antenna Polarization	Level (dB μ V/m)	20 dBc Limit (dB μ V/m)	Margin (dB)	Result
928.00	Vertical	61.96	91.81	29.85	Complied
931.79	Vertical	62.22	91.81	29.59	Complied

Results: Bottom/ Hopping / WIRA-40-linear-FCC

Frequency (MHz)	Antenna Polarization	Level (dB μ V/m)	20 dBc Limit (dB μ V/m)	Margin (dB)	Result
902.00	Vertical	91.76	93.79	2.03	Complied

Results: Top/ Hopping / WIRA-40-linear-FCC

Frequency (MHz)	Antenna Polarization	Level (dB μ V/m)	20 dBc Limit (dB μ V/m)	Margin (dB)	Result
928.00	Vertical	85.06	93.79	8.73	Complied

Result: Pass

Transmitter Band Edge Radiated Emissions / WIRA-40-linear-FCC

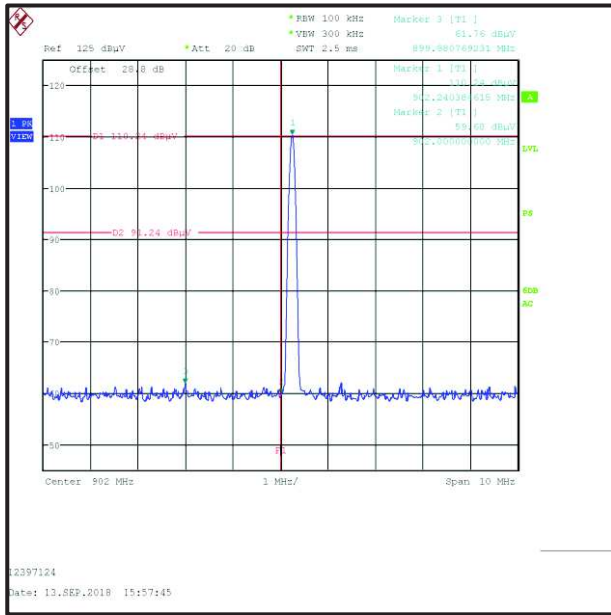

Lower Band Edge Peak Measurement

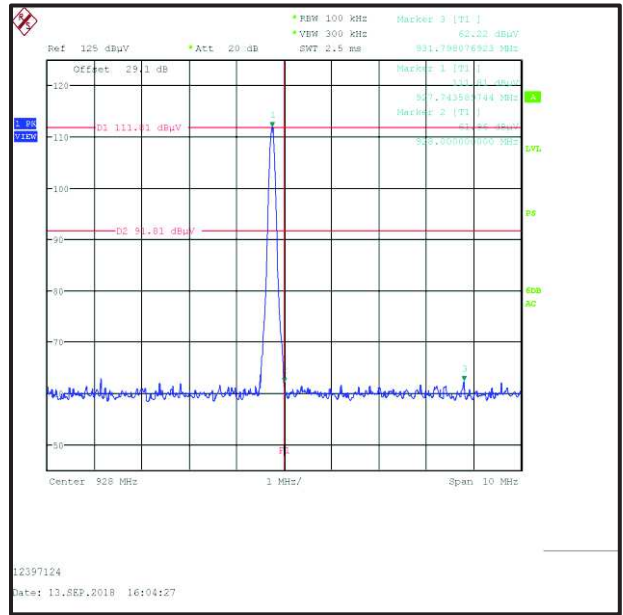

Upper Band Edge Peak Measurement

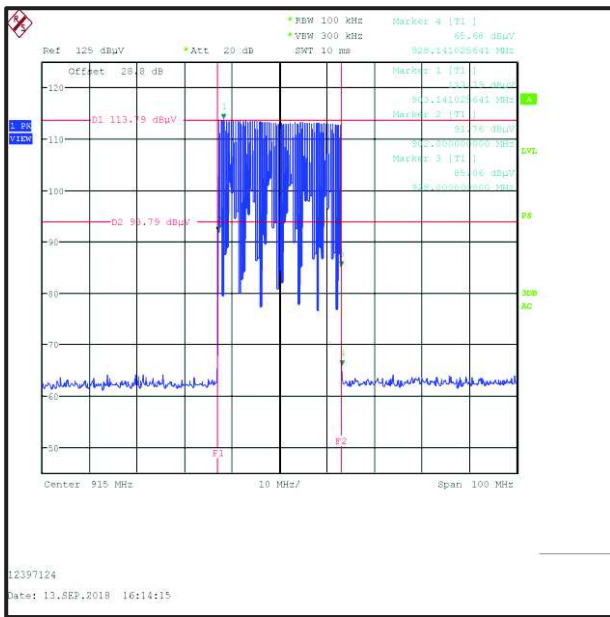

Lower and Upper Band Edge measurement Hopping mode

Results: Bottom/ WIRA-30-circular-FCC

Frequency (MHz)	Antenna Polarization	Level (dB μ V/m)	20 dBc Limit (dB μ V/m)	Margin (dB)	Result
899.96	Vertical	68.10	106.25	38.15	Complied
902.00	Vertical	65.01	106.25	41.24	Complied

Results: Top / WIRA-30-circular-FCC

Frequency (MHz)	Antenna Polarization	Level (dB μ V/m)	20 dBc Limit (dB μ V/m)	Margin (dB)	Result
928.00	Vertical	75.48	105.95	30.47	Complied
932.52	Vertical	62.22	105.95	43.73	Complied

Results: Bottom/ Hopping / WIRA-30-circular-FCC

Frequency (MHz)	Antenna Polarization	Level (dB μ V/m)	20 dBc Limit (dB μ V/m)	Margin (dB)	Result
902.00	Vertical	82.28	107.85	25.57	Complied

Results: Top/ Hopping / WIRA-30-circular-FCC

Frequency (MHz)	Antenna Polarization	Level (dB μ V/m)	20 dBc Limit (dB μ V/m)	Margin (dB)	Result
928.00	Vertical	82.54	107.85	25.31	Complied

Result: Pass

Transmitter Band Edge Radiated Emissions / WIRA-30-circular-FCC

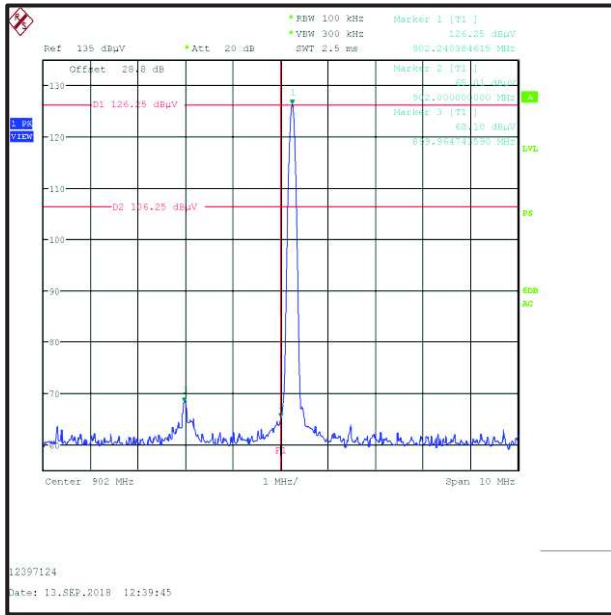

Lower Band Edge Peak Measurement

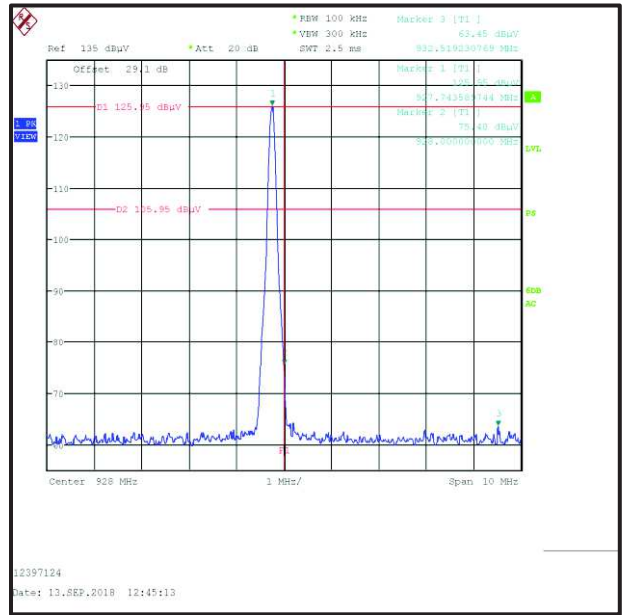

Upper Band Edge Peak Measurement

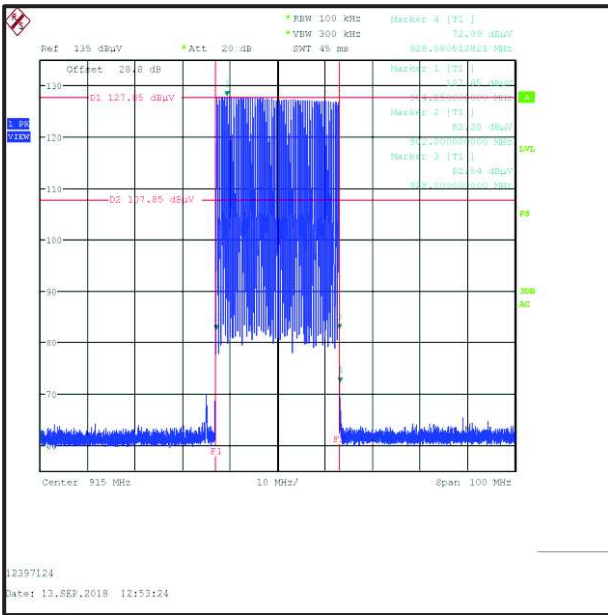

Lower and Upper Band Edge measurement Hopping mode

6. Measurement Uncertainty

The expression of uncertainty of a measurement result allows realistic comparison of results with reference values and limits given in specifications and standards.

The uncertainty of the result may need to be taken into account when interpreting the measurement results.

The reported expanded uncertainties below are based on a standard uncertainty multiplied by an appropriate coverage factor such that a confidence level of approximately 95% is maintained. For the purposes of this document "approximately" is interpreted as meaning "effectively" or "for most practical purposes".

Measurement Type	Confidence Level (%)	Calculated Uncertainty
AC Conducted Spurious Emissions	95%	±2.49 dB
Conducted Maximum Peak Output Power	95%	±0.59 dB
Conducted Spurious Emissions	95%	±0.59 dB
Band Edge Radiated Emissions	95%	±3.10 dB
Carrier Frequency Separation	95%	±92 Hz
Average Time of Occupancy	95%	±3.53 ns
20 dB Bandwidth	95%	±0.87 %

The methods used to calculate the above uncertainties are in line with those recommended within the various measurement specifications. Where measurement specifications do not include guidelines for the evaluation of measurement uncertainty the published guidance of the appropriate accreditation body is followed.

7. Used equipment

Test site: SR 1/2

ID	Manufacturer	Type	Model	Serial No.	Calibration Date	Cal. Cycle
1	Rohde & Schwarz	Antenna, Loop	HFH2-Z2	831247/012	8/5/2016	36
103	EMCO	Antenna, Horn	3115	9008/3485	7/20/2016	36
104	EMCO	Antenna, Horn	3115	9008/3486	7/20/2016	36
156	Rohde & Schwarz	V-Network	ESH3-Z6	843864/004	7/11/2018	12
350	Rohde & Schwarz	Receiver, EMI Test	ESIB7	836697/014	7/12/2018	12
377	BONN Elektronik	Amplifier, Low Noise Pre	BLMA 0118-1A	025294B	7/12/2018	12
383	Rohde & Schwarz	Antenna, Rod	HFH2-Z1	890151/11	7/14/2017	24
423	Bonn Elektronik	Amplifier, Low Noise Pre	BLMA 1840-1A	055929	7/12/2018	12
424	EMCO	Antenna, Horn	EMCO 3116	00046537	7/28/2016	24
425	Agilent	Generator, CW Signal	E8247C	MY43320849	7/10/2018	24
426	Agilent	Spectrum Analyzer	E4446A	US44020316	7/11/2018	24
460	Deisl	Turntable	DT 4250 S		n/a	n/a
465	Schwarzbeck	Antenna, Trilog Broadband	VULB 9168	9168-240	9/29/2017	24
474	Agilent	Analyzer, ENA Network	E5071C	MY46100912	7/13/2018	24
495	Rohde & Schwarz	Antenna, Log. - Periodical	HL050	100296	7/20/2016	24
496	Rohde & Schwarz	Antenna, log. - periodical	HL050	100297	7/20/2016	24
497	Schwarzbeck	Antenna, Biconical	VHBB 9124	423	7/7/2016	36
499	Schwarzbeck	Antenna, log.-per	VUSLP 9111	317	8/2/2016	36
587	Maturo	antenna mast, tilting	TAM 4.0-E	011/7180311	n/a	n/a
588	Maturo	Controller	NCD	029/7180311	n/a	n/a
591	Rohde & Schwarz	Receiver	ESU 40	100244/040	7/12/2018	12
607	Schwarzbeck	Antenna broadband horn antenna	BBHA 9170	9170-561	7/28/2016	24
608	Rohde & Schwarz	Switch Matrix	OSP 120	101227	4/8/2014	60
363	Wainwright	Notch Filter GSM900	WW-NF9	100002	Lab verification	n/a
611	Wainwright Instruments	Band Reject Filter DL LTE	WRCGV8-	1	Lab verification	n/a
612	Wainwright Instruments	Band Reject Filter UL LTE	WRCGV8-	1	Lab verification	n/a
613	Wainwright Instruments	Band Reject Filter WLAN/ BT	WRCTF12-	1	Lab verification	n/a
614	Wainwright Instruments	Highpass Filter 3GHz	WHKX10-	1	Lab verification	n/a
615	Wainwright Instruments	Highpass Filter 1GHz	WHKX12-	3	Lab verification	n/a
620	Bonn Elektronik	pre-amplifier	BLNA 0110-01N	1510111	7/12/2017	24
624	Wainwright	6 GHz high-pass filter	WHKX10-5850-6500-18000-40SS	5	Lab verification	n/a
628	Maturo	Antenna mast	CAM 4.0-P	224/19590716	n/a	n/a
629	Maturo	Kippeinrichtung	KE 2.5-R-M	MAT002	n/a	n/a

Test site: SR 9

ID	Manufacturer	Type	Model	Serial No.	Calibration Date	Cal. Cycle
424	EMCO	Antenna, Horn	EMCO 3116	00046537	7/28/2016	24
472	Rohde & Schwarz	Generator, Vektorsignal	SMU200A	102409	7/11/2018	12
592	Rohde & Schwarz	Wideband Radio Communication tester	CMW 500	119593	8/15/2017	12
622	Rohde & Schwarz	Step Attenuator	RSC	101904	7/12/2018	12
625	Schwarzbeck	Antenna, H-field	HFSL 7101	109	Verification - only relative measurements	n/a
626	Rohde & Schwarz	Bluetooth Tester	CBT	100481	Signaling Only	24
635	Rohde & Schwarz	Signal generator	SMB100A	179875	7/10/2018	12
636	Rohde & Schwarz	switching unit	OSP120	101698	7/12/2018	12
637	Rohde & Schwarz	Spectrum Analyzer	FSV40	101587	7/11/2018	12
423	Bonn Elektronik	Amplifier, Low Noise Pre	BLMA 1840-1A	55929	7/12/2018	24
451	Rohde & Schwarz	Power Meter, Dual Channel	NRVD	101190	7/10/2018	12
427	Rohde & Schwarz	Probe, Power Sensor	NRV-Z5	100106	7/12/2018	12
195	SPS	Power Supply	TOE8842-24	51455	Verified by Multimeter	12
216	Agilent	Multimeter	34401A	US36017458	7/11/2017	24
378	ESPEC/ Thermotec	Climatic Chamber	PL-1FT	5100869	8/9/2016	36

Test site: SR 7/8

ID	Manufacturer	Type	Model	Serial No.	Calibration Date	Cal. Cycle
22	Rohde & Schwarz	Artificial Mains	50 Ohm// 50uH	831767/014	7/11/2018	12
215	Rohde & Schwarz	Artificial Mains Network	9 kHz - 30 MHz; 3 phase	879675/002	7/11/2018	12
349	Rohde & Schwarz	Receiver, EMI Test	20 Hz - 7 GHz	836697/009	7/10/2018	12
616	Rohde & Schwarz	ISN	8 wire ISN for CAT6	101656	7/12/2018	12

8. Report Revision History

Version Number	Revision Details		
	Page No(s)	Clause	Details
1.0	39	-	Initial Version
1.1	9	3.5	Additional Antenna Information added
	23 to 57	5.2.5 to 5.2.7	Additional Antenna test results added