

Table of contents

1.	Product name	1
2.	Product number	1
3.	Overview.....	1
4.	Related standards	1
5.	Functions	1
5-1.	Constituents	1
5-1-1.	Block diagram of design structure	1
5-1-2.	Attached article	1
5-2.	Imaging	2
5-2-1.	Imaging method.....	2
5-2-2.	Lighting source.....	2
5-2-3.	Image format	2
5-2-4.	Imaging flow	2
5-2-5.	Imaging functions	2
5-2-6.	Transaction time (informative).....	3
5-3.	Contactless IC card communication	3
5-4.	Magnetic stripe reading (MSR).....	3
5-5.	Interface	3
5-5-1.	Host interface	3
5-5-2.	Host OS.....	3
5-6.	Intended cards	4
5-6-1.	Card length	4
5-6-2.	Card width.....	4
5-6-3.	Thickness of card that can be transported	4
5-6-4.	Thickness of card that can be read the magnetic stripe and images	4
5-6-5.	Material	4
5-6-6.	Opacity.....	4
5-6-7.	Distortional cards	4
5-7.	Common specifications	5
5-7-1.	Dimension	5
5-7-2.	Weight.....	5
5-7-3.	Power source	5
5-7-4.	Power consumption (at the DC jack)	5
5-7-5.	Card transfer method	5
5-7-6.	Card transferring speed	6
5-7-7.	Indicator lamp	6
5-7-8.	Gate indicator.....	6
5-7-9.	Sound noise	6
5-7-10.	Safety.....	6
5-7-11.	USB Logo.....	6
5-7-12.	SG-FG connection state	6
5-8.	Environmental condition.....	7
5-8-1.	Operating temperature and humidity	7
5-8-2.	Packing condition	7
5-8-3.	Vibration characteristic.....	7
5-8-4.	Mechanical shock characteristic.....	8
5-8-5.	Attitude.....	8
5-8-7.	Cable tension	8
5-8-8.	Electrostatic discharge immunity.....	8
5-8-9.	Electrical fast transient/burst immunity test (IEC61000-4-4)	8
5-8-10.	Thermal shock.....	9

6.	Image quality	9
6-1.	300dpi	9
6-1-1.	MTF	9
6-1-2.	Magnification of image	9
6-1-3.	Image skew	9
6-1-4.	Color quality	9
6-1-5.	Variation of projection	10
6-1-6.	Gradation accuracy	11
6-1-7.	Observation of image condition	12
6-1-8.	Target value of white level	12
6-1-9.	Deformation by transfer of card (extend and shorten)	12
6-2.	600dpi	12
7.	Reliability	13
7-1.	Product life	13
7-2.	Error ratio	13
7-3.	MTBF and Lamp life	13
7-4.	Environmental protection	13
8.	Product Warranty	14
8-1.	Warranty period:	14
8-2.	Repair	14
8-3.	Repair and maintenance	14
8-3-1.	Maintenance unit	14
8-3-2.	Period of maintenance works	14
8-3-3.	Cleaning notice	14
9.	Labeling	14
Appendix: Normal condition		15
Figure 1. Block diagram of design structure		15
Figure 2. Imaging area		16
Figure 3. Distortion		16
Notice		17

Revision History

<u>Rev</u>	<u>Date</u>	<u>Author</u>	<u>Description</u>
A	Nov 09 2010	H.Fukasawa	NEW
B	Nov 26 2010	H.Fukasawa	The read error rate of a magnetic stripe is filled in. Page 13 Section "7-2. Error ratio"
C	Dec 28 2010	H.Fukasawa	The disclaimer for the FCC standard agreement is added.

- Blank -

1. Product name

ID card reader

2. Product number

ISI220-0332

3. Overview

This device is an ID card reader for ID1 size card that is defined by ISO/IEC 7810. This device can be also used as a scanner that captures images of both sides on the card.

The device includes a molded front bezel, a case and an AC adapter module. It communicates with the host system by USB 2.0. The host software environment should be Microsoft Windows XP or Windows7.

Basic functions

- Transmit front and back images to host
- Communicate with contactless IC card defined by ISO/IEC 14443
- Read magnetic stripe data defined by ISO/IEC 7811-2 and -6
- PDF417 barcode reading by DLL

The interface with USB is specified by the driver specification "ASL-NP-20847-51".

4. Related standards

ISO/IEC 14443 ISO/IEC 7810
ISO/IEC 7811-1, -2 and -6 AAMVA
USB2.0 compatible *The logo is not received
ROHS compliance
UL 60950-1 2nd Edition

5. Functions

5-1. Constituents

5-1-1. Block diagram of design structure

See Figure 1.

5-1-2. Attached article

AC adapter

Parts number: E11A374A01
Vender name: UNIFIVE Co., Ltd.
Model number: UEA360-2425/JKOK-0003

White reference card

Parts number: S38A497A01

5-2. Image scanning

5-2-1. Imaging method

Monochrome Contact Image Sensor (CIS). This sensor can be used as a full-color sensor by the switching method with three colors LED.

5-2-2. Lighting source

R, G, B, and IR LED

Each wavelength is R: 630 nm, G: 520 nm, B: 465 nm and IR: 940 nm

5-2-3. Image format

BMP image format

5-2-4. Imaging flow

At 300 dpi: It is possible to take picture of three kinds of images at once.

Front face full-color and
Front face infrared grayscale and
Back face photopic grayscale.

At 600 dpi: It is possible to take picture only of one kind of times images.

Front face photopic grayscale

Or

Back face photopic grayscale

5-2-5. Imaging functions

At 300 dpi

Front face full-color	Light source	R,G,B
	Resolution	300 dpi
	Scan area	See Figure2
	Color	Full color

Front face infrared gray scale	Light source	IR
	Resolution	300 dpi
	Scan area	See Figure2
	Color	8 bit grayscale

Back face photopic grayscale	Light source	Mixed R,G,B
	Resolution	300 dpi
	Scan area	See Figure2
	Color	8 bit grayscale

At 600 dpi

Front face photopic grayscale	Light source	Mixed R,G,B
	Resolution	600 dpi
	Scan area	See Figure2
	Color	8 bit grayscale

Back face photopic grayscale	Light source	Mixed R,G,B
	Resolution	600 dpi
	Scan area	See Figure2
	Color	8 bit grayscale

5-2-6. Transaction time (informative)

Measurement condition:

Windows XP, CPU Celeron 1.6GHz 1GbytesUSB2.0 High Speed
when other high volume task is not operating

300dpi: loading card → Capturing 3 images at once → eject

Within 10 seconds

Within 12 seconds when RF IC communication is processing
without retry.

600dpi: loading card → front face imaging → back face imaging → eject

Within 14 seconds

Supplement: It use 600dpi image mode for barcode reading

5-3. Contactless IC card communication

Basically it can communicate Type A, Type B IC card that is compliant
with ISO/IEC 14443.

5-4. Magnetic stripe reading (MSR)

Intended card is compliant with ISO/IEC 7810,7811-2,-6
(JISX6301,6302-2,-6), and AAMVA specification. The reading process of
magnetic stripe is occurring at same time when the card is loading.

If the card is pulled or pushed by intention at insert timing , the reading
process might be fail.

5-5. Interface

5-5-1.Host interface

USB2.0 High speed PTP, HID composite device

5-5-2.Host OS

Windows XP SP2 or SP3

Windows 7(32-bit, 64-bit)

5-6. Intended cards

5-6-1. Card length

85.47~85.9mm

5-6-2. Card width

53.92~54.18mm

5-6-3. Thickness of card that can be transported

0.25~0.84mm

(Within 1.32 mm when the height of emboss is contained.)

The emboss area is specified by ISO/IEC 7811-1)

5-6-4. Thickness of card that can be read the magnetic stripe and images

0.5~0.84mm

(Within 1.32 mm when the height of emboss is contained.)

The emboss area is specified by ISO/IEC 7811-1)

5-6-5. Material

PVC, PVAC, PET-G

5-6-6. Opacity

More than 1.1 at Infrared wave length 700~950 nm

5-6-7. Distortional cards

Refer to the figure below.

It is possible to use it up to the amount of the height of "H" with the card that uniformly curves in longer direction and direction of shorter hand.

- 1) Transfer: "H" within 3mm (containing emboss)
- 2) Imaging: "H" within 2.5mm (containing emboss)
- 3) MSR: "H" less than 2.5mm (containing emboss)

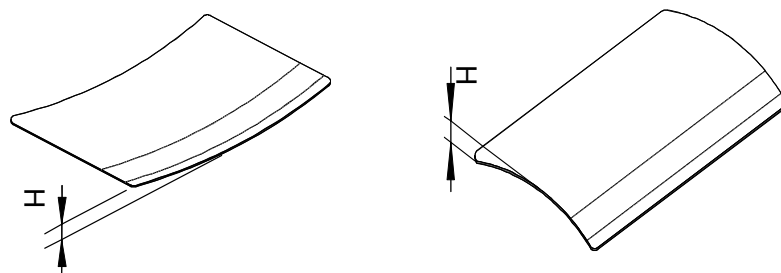

Bending of both direction in inside and outside

Note) Please do not use the card like the figures below.

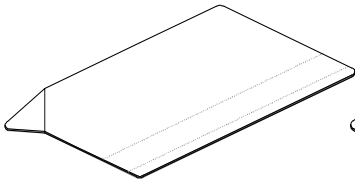

Bent card

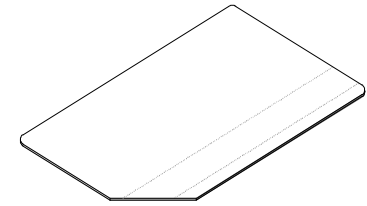
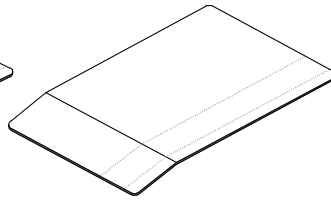

Defective card

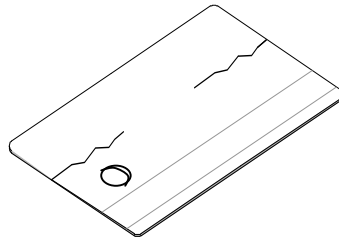

Cracked, holey card

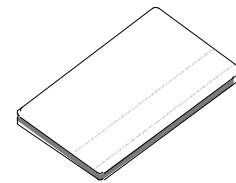

Non-standard size

Note) unavailable medium

Receipt sheet, business card, Medium with clip adheres, Medium with stapler adhered, etc.

5-7. Common specifications

5-7-1. Dimension

122(W) x 113(H) x 260(D) [mm]
 (The projection part is excluded.)
 Outside drawing T10A081A01

5-7-2. Mass

machine body	:less than 3kg
AC adapter	:less than 0.5kg

5-7-3. Power source

AC adapter: AC100V - 240V +24VDC
 Please do not insert and pull up the DC Jack during operation.

5-7-4. Power consumption (at the DC jack)

Standby: Less than 300mA
 Operating: Less than 2A
 Peak: less than 2.5A

5-7-5. Card transfer method

PWM controlled DC motor and drive rollers

5-7-6. Card transfer speed

Load/Eject: 250 mm/seconds
Imaging: 300dpi 83 mm/seconds
600dpi 52 mm/seconds

5-7-7. Indicator lamp

POWER: Green LAMP tern on / blinking/turn off
READY: Green LAMP tern on / blinking/turn off
ERROR: Red LAMP tern on / blinking/turn off
Each lighting mode is controlled by application program.

Please refer to driver specifications ASLL-NP-20847-51

5-7-8. Gate indicator

There is indicator lamp above the gate and side of the gate.
These lamps are controlled by application program.

Please refer to driver specifications ASLL-NP-20847-51

5-7-9. Sound noise

Operating : Within 65 dB
It is measured at a position 1m away from the device.
Measurement mode is A Lange FAST mode.
The operation sound of the shutter is excluded.

5-7-10. Safety

It is not certified by UL yet.

5-7-11. USB Logo

This device doesn't have USB Log.
But Sankyo tests it.

Vendor ID : "0x077A"
Product ID : "0x108A"
iManufacture : "NIDEC SANKYO CORPORATION"
iProduct : "ISI220-0332"

5-7-12. SG-FG connection state

SG and FG are connected at inside of this device.

5-8. Environmental condition

5-8-1. Operating condition

Operating: +0 degrees C ~ 40 degrees C
30%~85% R.H no condensation
Maximum wet bulb is +30 degrees C
No warped card when temperature is between 0~+5 degrees C.

Non operating: -10 degrees C~ 60 degrees C
20%~85% R.H
No condensation
Maximum wet bulb is +35 degrees C

5-8-2. Packing condition

Packed: -20 degrees C ~ 60 degrees C
10%~90% R.H
No condensation
Maximum wet bulb is +40 degrees C
There is no functional error in the testing.
The test is done after 12 hour since the device is return to normal condition.

5-8-3. Vibration characteristic

Operating: Vibration frequency: 5~50 Hz
Acceleration: 2.0 m/seconds² (0.2G) Constant
Sweep: Logarithmic change
Sweep time: 1minute / octave
5-50-5 Hz repeats, 10 minute
Total testing time: 0.5 hour (x, y, z every direction)
No abnormality is seen electrically and mechanically when the device is in use.

Non operating: Vibration frequency: 5~50 Hz
Acceleration: 4.0 m/seconds² (0.4G) constant
Maximum peak acceleration 30 m/secons² (3.0G)
Sweep: Logarithmic change
Sweep time: 1 minute / octave
5-50-5Hz repeats, 10 minute
Total testing time: 0.5 hour (x, y, z every direction)
No abnormality is seen electrically and mechanically when the device is in use (powered on).

5-8-4. Mechanical shock characteristic

Without packing:

Test method: Fixing at the end and drop down at another end
Lift up angle: 30 degrees
Lift up edge: Every 4 side
Number of time: 2 times per one side
Table situation: On the wood table
This test is done under none operating.

With packing:

Test method: Free fall
Lift up height: 600 mm
Falling direction: 1 corner, 3 ridges and 6 faces
Total falling times: 10 times
There is no degradation.

5-8-5. Attitude

Horizontal Attitude (Within +/- 5 degrees)
The device does not turn over in 15 degrees attitude.

5-8-7. Cable strength

The power cord does not break when it is applied force of 15.9 kgf (156N) in all directions.

5-8-8. Electrostatic discharge immunity

5-8-8-1. Aerial discharge (with cover case): +/- 10kV by 150pF / 330 ohms

It discharges 10 times per every electrical polarity (+/-) to the fixation screw that is on the rear of cover case and the gate in the front face.
Unrecoverable error does not be occurred during operation. The phenomenon that automatically returns to normal operation is permitted.

5-8-8-2. Contact discharge (without cover case): +/- 8kV by 150pF / 330 ohms

It discharges 25 times per every electrical polarity (+/-) to the metallic parts that appear when the cover case is removed.
This test is done while non-operating.
The device should operate normally after powered on.

5-8-9. Electrical fast transient/burst immunity test (IEC61000-4-4)

This test is done while operated. The phenomenon that automatically returns to normal operation is permitted.

5-8-9-1. AC power cable: +/- 1kV (between GND and AC every phase line)

5-8-9-2. USB cable: +/- 0.5 kV

5-8-10. Thermal shock

-10 degrees C / +60 degrees C

This test is done 10 cycles. One cycle requires one hour.

The device should operate normally after returned room temperature.

6. Image quality

6-1. 300dpi

6-1-1. MTF

Minimum 35%, typical 70%

MTF means ratio between 0.5line pare and 3.0 line pare

6-1-2. Magnification of image

Main scanning direction: Within +/- 3.2%

Vertical scanning direction: Within +/- 3.2%

6-1-3. Image skew

+/- 1.5 degrees see figure 3-1

Eliminate Cracked and deformed card

6-1-4. Color quality

6-1-4-1. At block D on the gradation chart

Difference of image data between red, green, blue are less than 10 of 255 LSB.

6-1-4-2. At block B on the gradation chart

Difference of image data between red, green, blue are less than 7 of 255 LSB.

6-1-4-3. Computation method

Difference of image data = Maximum (| R - G | , | G - B | , | R - B |)

Gradation chart: G05A622A01

Gamma: 1

Procedure:

1) Calibrate image sensor with white reference card.

- 2) Capture image
- 3) Average gray level of every block and every color
- 4) Calculate the difference of image data

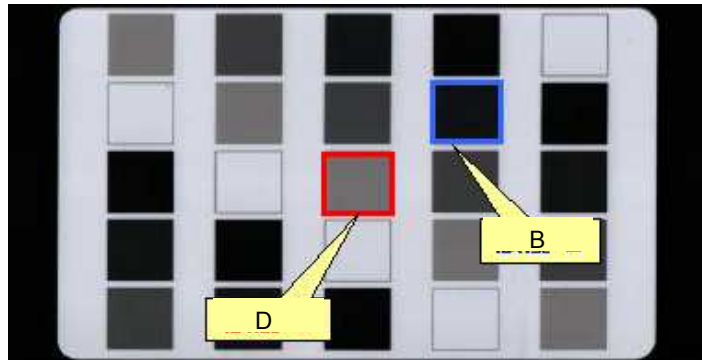

Gradation chart

6-1-5. Variation of projection

6-1-5-1. Integrated value of main scanning direction

The difference to the integrated value around of the center is within 10%.

6-1-5-2. Computation method

Measurement area is without every 50 pixels from upper end and lower end. Gamma is 1.

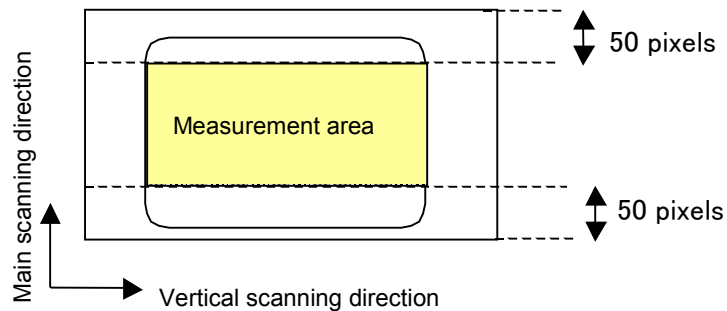

Procedure: 1) Calibrate image sensor with white reference card.

2) Capture image of same card.

3) Calculate integrated value of main scanning direction

4) Calculate difference of both card ends from the center

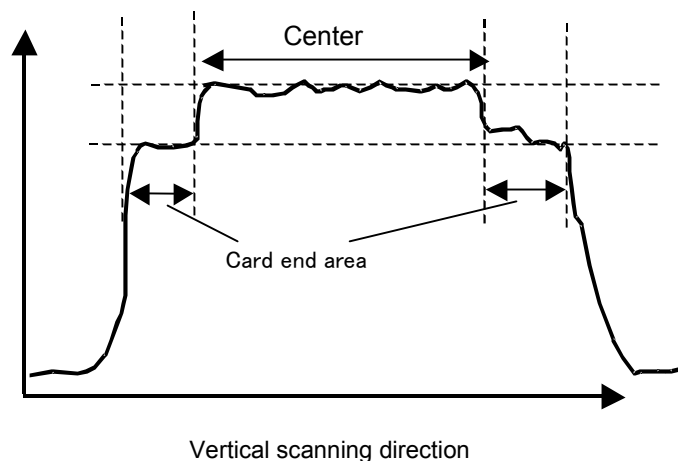

6-1-6. Gradation accuracy

6-1-6-1. The value of every block of gradation card

	A	B	C	D	E
Average	6	18	57	111	210
Maximum	24	37	75	128	231
Minimum	0	0	38	93	189

6-1-6-2. Computation method

Measurement area: 3 column of the center, Gamma is 1.

- Procedure:
- 1) Calibrate image sensor with white reference card.
 - 2) Capture image of gradation card
 - 3) Calculate average of every block

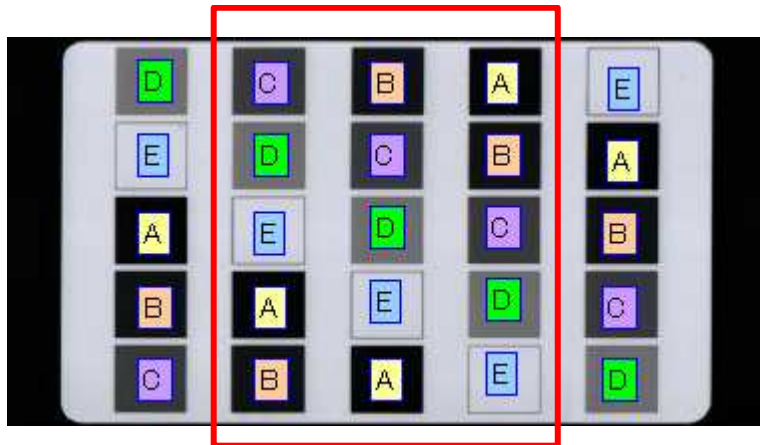

Gradation card

6-1-7. Observation of image condition

It is inspected smear, regional noise and etc.
For example, depend on cross talk noise, beat noise.

6-1-8. Target value of white level

The target value is 229 when the white reference card is read.
The white reference card is "S38A497A01".

6-1-9. Deformation by transfer of card (extend and shorten)

Long wave deformation: +/- 3 % (accuracy of card length)
Momentary deformation: +/- 25 %
(at 25.5mm from top of card and 17mm from back end)
Momentary deformation:
The accuracy of every 2mm regions is within following.

$-1 \leq x \leq +1$ [pixel] : No object
 $-2 \leq x < -1$ [pixel], $+1 < x \leq +2$ [pixel] : Within 5 points
 $-4 \leq x < -2$ [pixel], $+2 < x \leq +4$ [pixel] : Within 3 points

2mm region contains 24 pixels at 300dpi.

Deformation of main scanning direction: within +/- 3 pixels
(See Figure 3-2)

Used card: Thickness is 0.76 mm, flat and no emboss card.

6-2. 600dpi

The PDF417 barcode on the reference card should be read.

7. Reliability

7-1. Product life

100,000 transactions or 7 year

One transaction contains follows.

“Card load → Transfer → image scan → Transfer → Eject”

Ambient environment is room condition.

Maintenance is required.

7-2. Error ratio

Within 1/10000 transaction

Error means card jam, read error and false operation.

Normal flat card is used for the test in room condition.



Magnetic stripe read error rate: Less than 5 errors per 5,000 cycles when the test card as SANACARD-T5 flat is used in room condition.

7-3. MTBF and Lamp life

MTBF of every circuit:

Main unit circuit: more than 62,000hours

AC adapter circuit: more than 62,000 hours

Lamp life

1,000 hours (degrading -20%) cumulative

3,000 hours (degrading -30%) cumulative

Testing condition: 20 degrees C, Duty 20%

Note) 1,000 hours is even equal to 27,000,000 transactions.

7-4. Environmental protection

RoHS compliant

8. Product Warranty

8-1. Warranty period:

One year from delivery

If there are any problem or it becomes malfunctioning within one year after it passes delivery incoming inspection, it should be repaired or replaced in warranty free of charge.

8-2. Repair

After the above warranty period, any repair or replacement should be made as out of warranty and be charged.

(Any serious design fault or manufacturing failure should be discussed how to be handled between the buyer and the seller.

8-3. Repair and maintenance

8-3-1. Maintenance unit

1.	AC adapter (with AC cable)	E11A374A01
2.	AC cable (single item)	S30A937A01
3.	White reference card	S38A497A01

8-3-2. Period of maintenance works

Maintenance period is 1 year. (Informative)

Cleaning is needed when error occurred.

8-3-3. Cleaning notice

Solvent use is not permitted.

Neutral detergent is recommended for cleaning.

9. Labeling

The label on the unit contains the following contents.

Model name

Lot Number

Unit revision

See outside drawing.

Appendix: Normal condition

Temperature: +20 +/- 5 degrees C
 Humidity: 35 % ~ 60% R.H
 Attitude: Horizontal

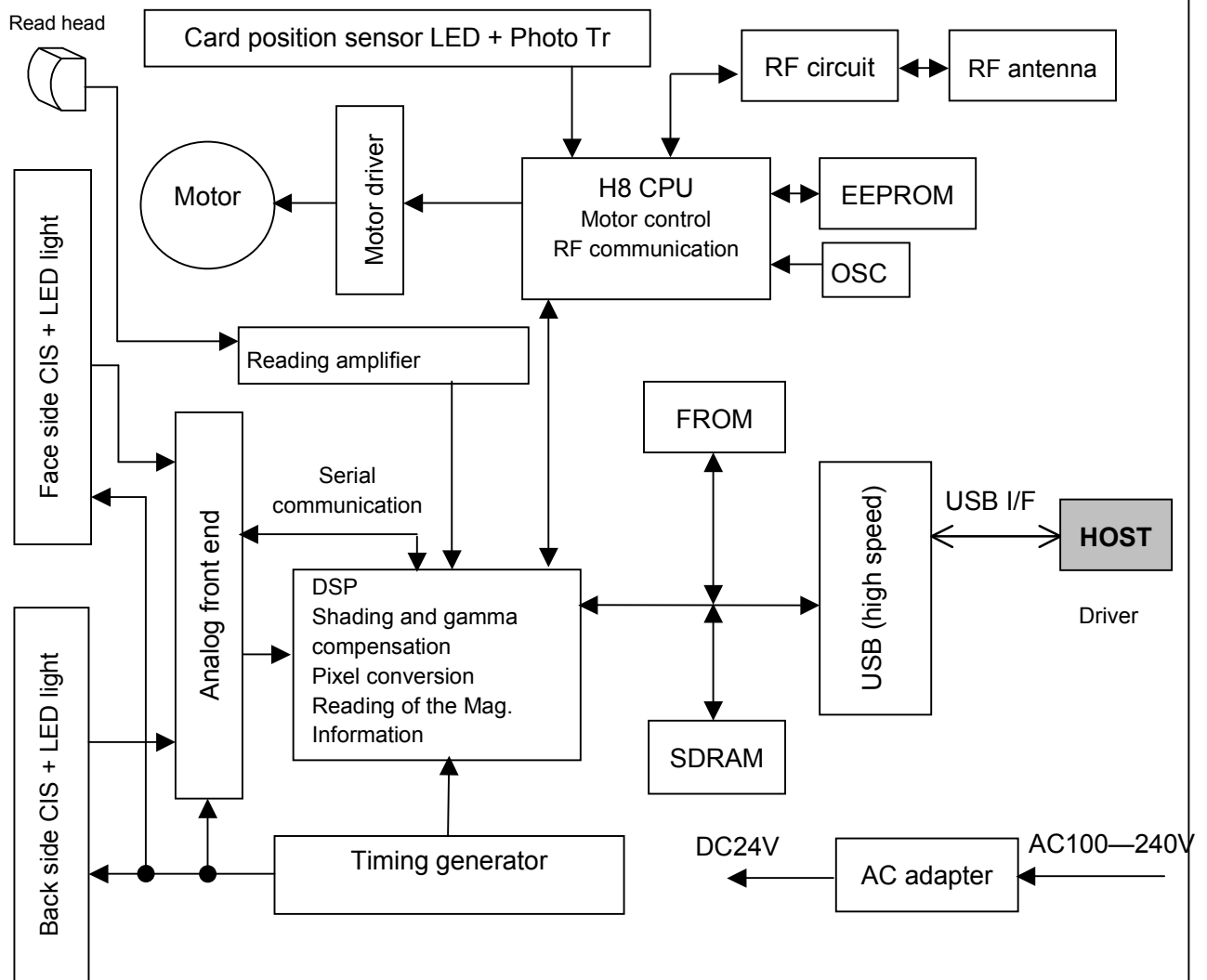

Figure 1. Block diagram of design structure

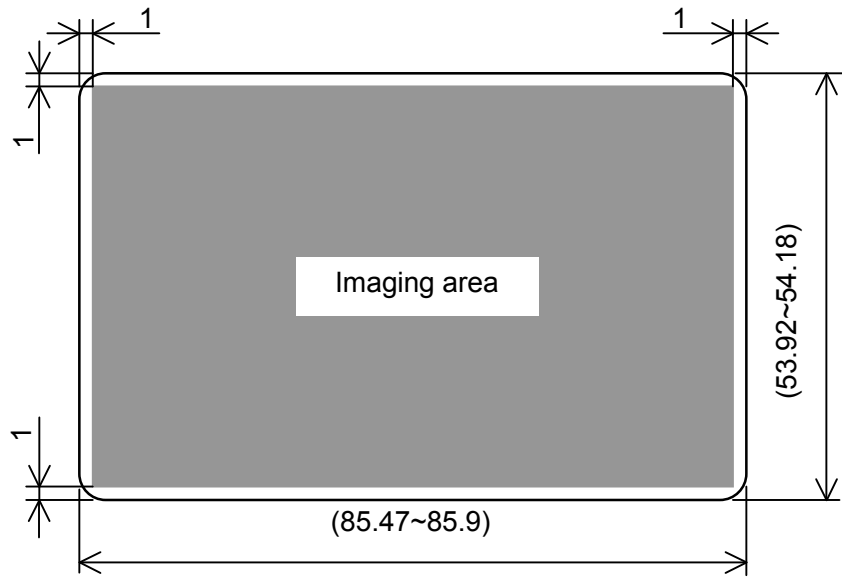

Figure 2. Imaging area

Skew = $A * \tan(A/B)$: B dimension is 50.8mm (600pixels)

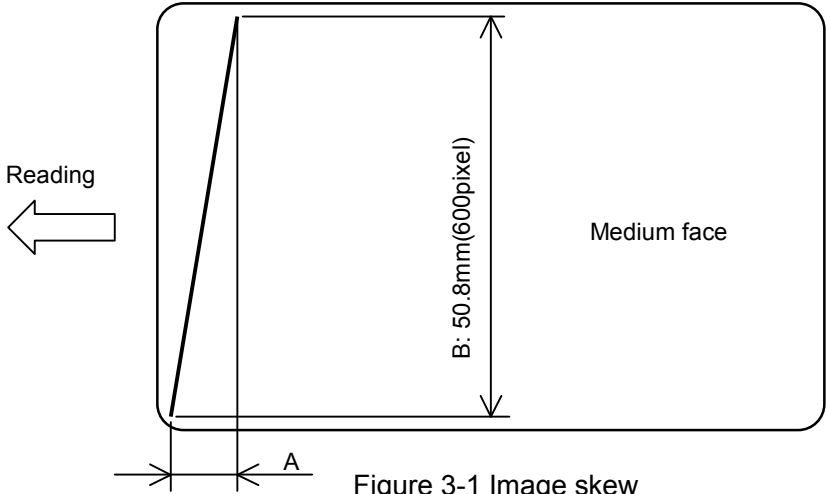

Figure 3-1 Image skew

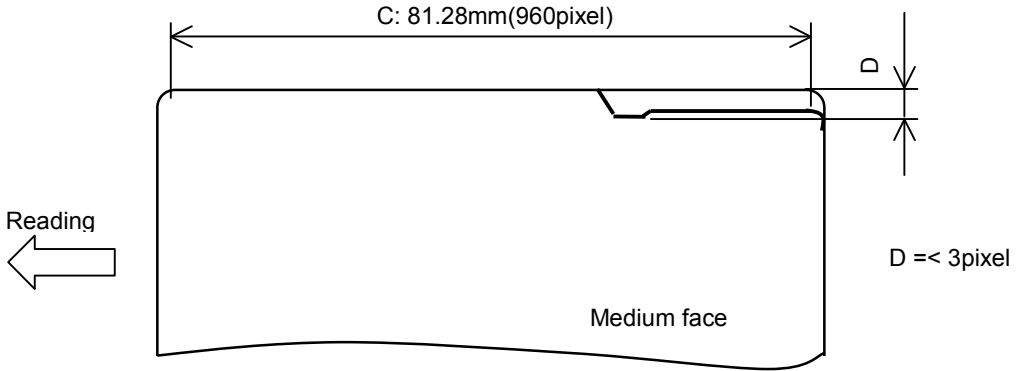

Figure 3-2 Image deformation

Figure 3. Distortion

NOTICE

This equipment has been tested and found to comply with the limits for a Class B digital device, pursuant to part 15 of the FCC Rules. These limits are designed to provide reasonable protection against harmful interference in a residential installation. This equipment generates, uses and can radiate radio frequency energy and, if not installed and used in accordance with the instructions, may cause harmful interference to radio communications. However, there is no guarantee that interference will not occur in a particular installation. If this equipment does cause harmful interference to radio or television reception, which can be determined by turning the equipment off and on, the user is encouraged to try to correct the interference by one or more of the following measures:

- Reorient or relocate the receiving antenna.
- Increase the separation between the equipment and receiver.
- Connect the equipment into an outlet on a circuit different from that to which the receiver is connected.
- Consult the dealer or an experienced radio/TV technician for help.

FCC WARNING

Change or modifications not expressly approved by the party responsible for compliance could void the user's authority to operate the equipment.

---- **End of Document** ----