



FCC RADIO TEST REPORT-BT

FCC ID:WJ5-AS8P

Product : Sacool Pro

Trade Name : Avantree

Model Name : BTHS-AS8P

Serial Model : N/A

Report No. : NTEK-2015NT0325499F1

Prepared for

Avantronics Limited

The 4th Floor, Yuepeng Building, No.1019 Jiabin Rd, Luohu
District, Shenzhen,China

Prepared by

Shenzhen NTEK Testing Technology Co., Ltd.

1/F, Building E, Fenda Science Park, Sanwei Community, Xixiang Street
Bao'an District, Shenzhen P.R. China

Tel.: +86-0755-61156588 Fax.: +86-0755-61156599

Website: www.ntek.org.cn

TEST RESULT CERTIFICATION

Applicant's name : Avantronics Limited
Address : The 4th Floor, Yuepeng Building, No.1019 Jiabin Rd, Luohu District, Shenzhen,China
Manufacture's Name..... : Avantronics Limited
Address : The 4th Floor, Yuepeng Building, No.1019 Jiabin Rd, Luohu District, Shenzhen,China

Product description

Product name : Sacool Pro
Model and/or type reference : BTHS-AS8P
Serial Model : N/A

Standards : FCC Part15.247: 01 Oct. 2014

Test procedure ANSI C63.4-2014

This device described above has been tested by NTEK, and the test results show that the equipment under test (EUT) is in compliance with the FCC requirements. And it is applicable only to the tested sample identified in the report.

This report shall not be reproduced except in full, without the written approval of NTEK, this document may be altered or revised by NTEK, personal only, and shall be noted in the revision of the document.

Date of Test

Date (s) of performance of tests : 25 Mar. 2015 ~ 15 Apr. 2015

Date of Issue..... : 15 Apr. 2015

Test Result..... : **Pass**

Testing Engineer : Eileen Liu.
(Eileen Liu)

Technical Manager : Brown Lu
(Brown Lu)

Authorized Signatory : Bill Yao
(Bill Yao)

Table of Contents

	Page
1 . SUMMARY OF TEST RESULTS	5
1.1 TEST FACILITY	6
1.2 MEASUREMENT UNCERTAINTY	6
2 . GENERAL INFORMATION	7
2.1 GENERAL DESCRIPTION OF EUT	7
2.2 DESCRIPTION OF TEST MODES	9
2.3 TABLE OF PARAMETERS OF TEXT SOFTWARE SETTING	9
2.4 BLOCK DIGRAM SHOWING THE CONFIGURATION OF SYSTEM TESTED	10
2.5 DESCRIPTION OF SUPPORT UNITS(CONDUCTED MODE)	11
2.6 EQUIPMENTS LIST FOR ALL TEST ITEMS	12
3 . EMC EMISSION TEST	13
3.1 CONDUCTED EMISSION MEASUREMENT	13
3.1.1 POWER LINE CONDUCTED EMISSION LIMITS	13
3.1.2 TEST PROCEDURE	14
3.1.3 DEVIATION FROM TEST STANDARD	14
3.1.4 TEST SETUP	14
3.1.5 EUT OPERATING CONDITIONS	14
3.1.6 TEST RESULTS	15
3.2 RADIATED EMISSION MEASUREMENT	17
3.2.1 RADIATED EMISSION LIMITS	17
3.2.2 TEST PROCEDURE	18
3.2.3 DEVIATION FROM TEST STANDARD	18
3.2.4 TEST SETUP	19
3.2.5 EUT OPERATING CONDITIONS	20
3.2.6 TEST RESULTS (BELOW 30 MHZ)	21
3.2.7 TEST RESULTS (BETWEEN 30M – 1000 MHZ)	22
3.2.8 TEST RESULTS (ABOVE 1000 MHZ)	24
4 . NUMBER OF HOPPING CHANNEL	26
4.1 APPLIED PROCEDURES / LIMIT	26
4.1.1 TEST PROCEDURE	26
4.1.2 DEVIATION FROM STANDARD	26
4.1.3 TEST SETUP	26
4.1.4 EUT OPERATION CONDITIONS	26
4.1.5 TEST RESULTS	27
5 . AVERAGE TIME OF OCCUPANCY	28
5.1 APPLIED PROCEDURES / LIMIT	28

Table of Contents

	Page
5.1.1 TEST PROCEDURE	28
5.1.2 DEVIATION FROM STANDARD	28
5.1.3 TEST SETUP	29
5.1.4 EUT OPERATION CONDITIONS	29
5.1.5 TEST RESULTS	30
6 . HOPPING CHANNEL SEPARATION MEASUREMENT	36
6.1 APPLIED PROCEDURES / LIMIT	36
6.1.1 TEST PROCEDURE	36
6.1.2 DEVIATION FROM STANDARD	36
6.1.3 TEST SETUP	36
6.1.4 EUT OPERATION CONDITIONS	36
6.1.5 TEST RESULTS	37
7 . BANDWIDTH TEST	43
7.1 APPLIED PROCEDURES / LIMIT	43
7.1.1 TEST PROCEDURE	43
7.1.2 DEVIATION FROM STANDARD	43
7.1.3 TEST SETUP	43
7.1.4 EUT OPERATION CONDITIONS	43
7.1.5 TEST RESULTS	44
8 . PEAK OUTPUT POWER TEST	50
8.1 APPLIED PROCEDURES / LIMIT	50
8.1.1 TEST PROCEDURE	50
8.1.2 DEVIATION FROM STANDARD	50
8.1.3 TEST SETUP	50
8.1.4 EUT OPERATION CONDITIONS	50
8.1.5 TEST RESULTS	51
9 . 100 KHZ BANDWIDTH OF FREQUENCY BAND EDGE	57
9.1 DEVIATION FROM STANDARD	57
9.2 TEST SETUP	57
9.3 EUT OPERATION CONDITIONS	57
9.4 TEST RESULTS	58
10 . ANTENNA REQUIREMENT	65
10.1 STANDARD REQUIREMENT	65
10.2 EUT ANTENNA	65
11 . EUT TEST PHOTO	66
APPENDIX-PHOTOGRAPHS OF EUT CONSTRUCTIONAL DETAILS	

1. SUMMARY OF TEST RESULTS

Test procedures according to the technical standards:

FCC Part15 (15.247) , Subpart C			
Standard Section	Test Item	Judgment	Remark
15.207	Conducted Emission	PASS	
15.247(a)(1)	Hopping Channel Separation	PASS	
15.247(b)(1)	Peak Output Power	PASS	
15.247(c)	Radiated Spurious Emission	PASS	
15.247(a)(iii)	Number of Hopping Frequency	PASS	
15.247(a)(iii)	Dwell Time	PASS	
15.247(a)(1)	Bandwidth	PASS	
15.205	Band Edge Emission	PASS	
15.203	Antenna Requirement	PASS	

NOTE:

(1) "N/A" denotes test is not applicable in this Test Report

1.1 TEST FACILITY

NTEK Testing Technology Co., Ltd
 Add. : 1/F, Building E, Fenda Science Park, Sanwei Community, Xixiang Street, Bao'an District, Shenzhen P.R. China.
 FCC Registration No.:238937; IC Registration No.:9270A-1
 CNAS Registration No.:L5516

1.2 MEASUREMENT UNCERTAINTY

The reported uncertainty of measurement $y \pm U$, where expanded uncertainty U is based on a standard uncertainty multiplied by a coverage factor of $k=2$, providing a level of confidence of approximately **95 %**.

No.	Item	Uncertainty
1	Conducted Emission Test	$\pm 1.38\text{dB}$
2	RF power,conducted	$\pm 0.16\text{dB}$
3	Spurious emissions,conducted	$\pm 0.21\text{dB}$
4	All emissions,radiated(<1G)	$\pm 4.68\text{dB}$
5	All emissions,radiated(>1G)	$\pm 4.89\text{dB}$
6	Temperature	$\pm 0.5^\circ\text{C}$
7	Humidity	$\pm 2\%$

2. GENERAL INFORMATION

2.1 GENERAL DESCRIPTION OF EUT

Equipment	Sacool Pro	
Trade Name	Avantree	
Model Name	BT HS-AS8P	
Serial Model	N/A	
Model Difference	N/A	
Product Description	The EUT is a Sacool Pro BT	
	Operation Frequency:	2402~2480 MHz
	Modulation Type:	BT(GFSK): GFSK BT EDR(π /4-DQPSK): π /4-DQPSK BT EDR(8-DPSK): 8-DPSK
	Bit Rate of Transmitter	GFSK/ π /4-DQPSK/8-DPSK
	Number Of Channel	79 CH
	Antenna Designation:	Please see Note 3.
Channel List	Please refer to the Note 2.	
Adapter	N/A	
Battery	DC 3.7V, 120mAh	
Connecting I/O Port(s)	Please refer to the User's Manual	

Note:

1. For a more detailed features description, please refer to the manufacturer's specifications or the User's Manual.

2.

Channel List					
Channel	Frequency (MHz)	Channel	Frequency (MHz)	Channel	Frequency (MHz)
00	2402	27	2429	54	2456
01	2403	28	2430	55	2457
02	2404	29	2431	56	2458
03	2405	30	2432	57	2459
04	2406	31	2433	58	2460
05	2407	32	2434	59	2461
06	2408	33	2435	60	2462
07	2409	34	2436	61	2463
08	2410	35	2437	62	2464
09	2411	36	2438	63	2465
10	2412	37	2439	64	2466
11	2413	38	2440	65	2467
12	2414	39	2441	66	2468
13	2415	40	2442	67	2469
14	2416	41	2443	68	2470
15	2417	42	2444	69	2471
16	2418	43	2445	70	2472
17	2419	44	2446	71	2473
18	2420	45	2447	72	2474
19	2421	46	2448	73	2475
20	2422	47	2449	74	2476
21	2423	48	2450	75	2477
22	2424	49	2451	76	2478
23	2425	50	2452	77	2479
24	2426	51	2453	78	2480
25	2427	52	2454		
26	2428	53	2455		

3.

Table for Filed Antenna

Ant	Brand	Model Name	Antenna Type	Connector	Gain (dBi)	NOTE
1	N/A	N/A	PCB Antenna	N/A	1.0	BT Antenna

2.2 DESCRIPTION OF TEST MODES

To investigate the maximum EMI emission characteristics generates from EUT, the test system was pre-scanning tested base on the consideration of following EUT operation mode or test configuration mode which possible have effect on EMI emission level. Each of these EUT operation mode(s) or test configuration mode(s) mentioned above was evaluated respectively.

Pretest Mode	Description
Mode 1	CH00
Mode 2	CH39
Mode 3	CH78
Mode 4	Keeping TX mode

For Conducted Emission	
Final Test Mode	Description
Mode 4	Keeping TX mode

For Radiated Emission	
Final Test Mode	Description
Mode 1	CH00
Mode 2	CH39
Mode 3	CH78

Note:

- (1) The measurements are performed at the highest, middle, lowest available channels.
- (2) EUT adjust the input voltage from 85V to 115V,no find influence.
- (3)The data rate was set in 8-DPSK for radiated emission due to the highest RF output power.

2.3 TABLE OF PARAMETERS OF TEXT SOFTWARE SETTING

During testing channel & power controlling software provided by the customer was used to control the operating channel as well as the output power level. The RF output power selection is for the setting of RF output power expected by the customer and is going to be fixed on the firmware of the final end product power parameters of FHSS

Test software Version	Test program: Broadcom		
Frequency	2402 MHz	2441 MHz	2480 MHz
Parameters(1/2/8-DPSK)	DEF	DEF	DEF

2.4 BLOCK DIGRAM SHOWING THE CONFIGURATION OF SYSTEM TESTED

Radiated Spurious Emission Test

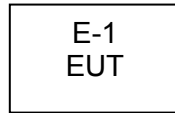

Conducted Emission Test

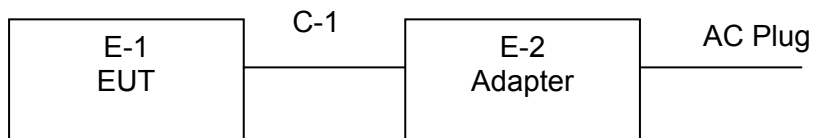

2.5 DESCRIPTION OF SUPPORT UNITS(CONDUCTED MODE)

The EUT has been tested as an independent unit together with other necessary accessories or support units. The following support units or accessories were used to form a representative test configuration during the tests.

Item	Equipment	Mfr/Brand	Model/Type No.	Series No.	Note
E-1	Sacool Pro	Avantree	BTHS-AS8P	N/A	EUT
E-2	Adapter	HP	AD1	N/A	FCC VOC approved

Item	Shielded Type	Ferrite Core	Length	Note
C-1	NO	NO	120cm	

Note:

- (1) The support equipment was authorized by Declaration of Confirmation.
- (2) For detachable type I/O cable should be specified the length in cm in 『Length』 column.
- (3) “YES” is means “shielded” “with core”; “NO” is means “unshielded” “without core”.

2.6 EQUIPMENTS LIST FOR ALL TEST ITEMS

Radiation Test equipment

Item	Kind of Equipment	Manufacturer	Type No.	Serial No.	Last calibration	Calibrated until	Calibration period
1	Spectrum Analyzer	Agilent	E4407B	MY45108040	2014.07.06	2015.07.05	1 year
2	Test Receiver	R&S	ESPI	101318	2014.06.07	2015.06.06	1 year
3	Bilog Antenna	TESEQ	CBL6111D	31216	2014.07.06	2015.07.05	1 year
4	50Ω Coaxial Switch	Anritsu	MP59B	6200264416	2014.06.07	2015.06.06	1 year
5	Spectrum Analyzer	ADVANTEST	R3132	150900201	2014.06.07	2015.06.06	1 year
6	Horn Antenna	EM	EM-AH-10180	2011071402	2014.07.06	2015.07.05	1 year
7	Horn Ant	Schwarzbeck	BBHA 9170	9170-181	2014.07.06	2015.07.05	1 year
8	Amplifier	EM	EM-30180	060538	2014.12.22	2015.12.21	1 year
9	Loop Antenna	ARA	PLA-1030/B	1029	2014.06.08	2015.06.07	1 year
10	Power Meter	R&S	NRVS	100696	2014.07.06	2015.07.05	1 year
11	Power Sensor	R&S	URV5-Z4	0395.1619.05	2014.07.06	2015.07.05	1 year

Conduction Test equipment

Item	Kind of Equipment	Manufacturer	Type No.	Serial No.	Last calibration	Calibrated until	Calibration period
1	Test Receiver	R&S	ESCI	101160	2014.06.06	2015.06.05	1 year
2	LISN	R&S	ENV216	101313	2014.08.24	2015.08.23	1 year
3	LISN	EMCO	3816/2	00042990	2014.08.24	2015.08.23	1 year
4	50Ω Coaxial Switch	Anritsu	MP59B	6200264417	2014.06.07	2015.06.06	1 year
5	Passive Voltage Probe	R&S	ESH2-Z3	100196	2014.06.07	2015.06.06	1 year
6	Absorbing clamp	R&S	MOS-21	100423	2014.06.08	2015.06.07	1 year
7	Test Cable	N/A	C01	N/A	2014.06.08	2015.06.07	1 year
8	Test Cable	N/A	C02	N/A	2014.06.08	2015.06.07	1 year
9	Test Cable	N/A	C03	N/A	2014.06.08	2015.06.07	1 year

1	Attenuation	MCE	24-10-34	BN9258	2014.06.08	2015.06.07	1 year
---	-------------	-----	----------	--------	------------	------------	--------

3. EMC EMISSION TEST

3.1 CONDUCTED EMISSION MEASUREMENT

3.1.1 POWER LINE CONDUCTED EMISSION Limits (Frequency Range 150KHz-30MHz)

FREQUENCY (MHz)	Class A (dBuV)		Class B (dBuV)		Standard
	Quasi-peak	Average	Quasi-peak	Average	
0.15 -0.5	79.00	66.00	66 - 56 *	56 - 46 *	CISPR
0.50 -5.0	73.00	60.00	56.00	46.00	CISPR
5.0 -30.0	73.00	60.00	60.00	50.00	CISPR

0.15 -0.5	79.00	66.00	66 - 56 *	56 - 46 *	FCC
0.50 -5.0	73.00	60.00	56.00	46.00	FCC
5.0 -30.0	73.00	60.00	60.00	50.00	FCC

Note:

- (1) The tighter limit applies at the band edges.
- (2) The limit of " * " marked band means the limitation decreases linearly with the logarithm of the frequency in the range.

The following table is the setting of the receiver

Receiver Parameters	Setting
Attenuation	10 dB
Start Frequency	0.15 MHz
Stop Frequency	30 MHz
IF Bandwidth	9 kHz

3.1.2 TEST PROCEDURE

- a. The EUT was placed 0.8 meters from the horizontal ground plane with EUT being connected to the power mains through a line impedance stabilization network (LISN). All other support equipments powered from additional LISN(s). The LISN provide 50 Ohm/ 50uH of coupling impedance for the measuring instrument.
- b. Interconnecting cables that hang closer than 40 cm to the ground plane shall be folded back and forth in the center forming a bundle 30 to 40 cm long.
- c. I/O cables that are not connected to a peripheral shall be bundled in the center. The end of the cable may be terminated, if required, using the correct terminating impedance. The overall length shall not exceed 1 m.
- d. LISN at least 80 cm from nearest part of EUT chassis.
- e. For the actual test configuration, please refer to the related Item –EUT Test Photos.

3.1.3 DEVIATION FROM TEST STANDARD

No deviation

3.1.4 TEST SETUP

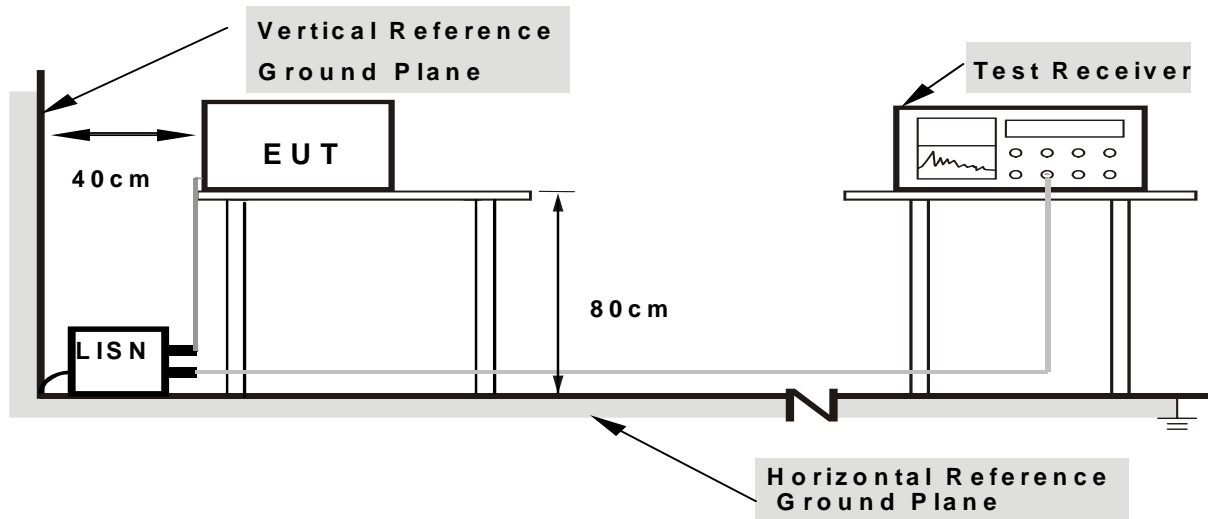

- Note:**
- 1.Support units were connected to second LISN.
 - 2.Both of LISNs (AMN) are 80 cm from EUT and at least 80 from other units and other metal planes

3.1.5 EUT OPERATING CONDITIONS

The EUT was configured for testing in a typical fashion (as a customer would normally use it). The EUT has been programmed to continuously transmit during test. This operating condition was tested and used to collect the included data.

3.1.6 TEST RESULTS

EUT :	Sacool Pro	Model Name :	BTHS-AS8P
Temperature :	26 °C	Relative Humidity :	54%
Pressure :	1010hPa	Phase :	L
Test Voltage :	DC 5.0V from adapter AC 120V/60Hz	Test Mode :	Mode 4

Frequency (MHz)	Reading Level (dBμV)	Correct Factor (dB)	Measure-ment (dBμV)	Limits (dBμV)	Margin (dB)	Remark
0.2938	19.18	9.61	28.79	60.41	-31.62	QP
0.2938	11.32	9.61	20.93	50.41	-29.48	AVG
0.4300	27.75	9.65	37.40	57.25	-19.85	QP
0.4300	20.46	9.65	30.11	47.25	-17.14	AVG
0.6100	19.38	9.65	29.03	56.00	-26.97	QP
0.6100	11.48	9.65	21.13	46.00	-24.87	AVG
1.0140	15.27	9.61	24.88	56.00	-31.12	QP
1.0140	8.08	9.61	17.69	46.00	-28.31	AVG
1.8260	18.12	9.55	27.67	56.00	-28.33	QP
1.8260	8.66	9.55	18.21	46.00	-27.79	AVG
2.6259	16.37	9.53	25.90	56.00	-30.10	QP
2.6259	8.23	9.53	17.76	46.00	-28.24	AVG

Remark:

1. All readings are Quasi-Peak and Average values.
2. Factor = Insertion Loss + Cable Loss.

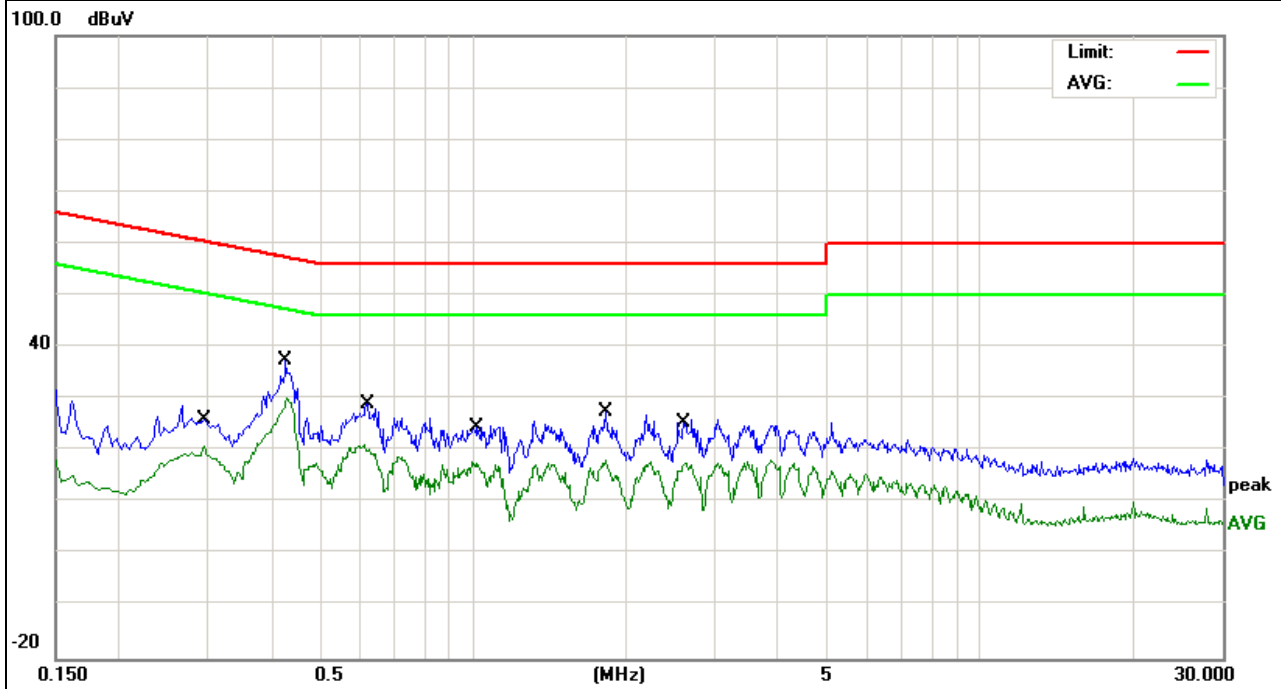

EUT :	Sacool Pro	Model Name :	BTHS-AS8P
Temperature :	26 °C	Relative Humidity :	54%
Pressure :	1010hPa	Phase :	N
Test Voltage :	DC 5.0V from adapter AC 120V/60Hz	Test Mode :	Mode 4

Frequency (MHz)	Reading Level (dBμV)	Correct Factor (dB)	Measure-ment (dBμV)	Limits (dBμV)	Margin (dB)	Remark
0.2740	21.27	9.61	30.88	60.99	-30.11	QP
0.2740	6.64	9.61	16.25	50.99	-34.74	AVG
0.4260	30.33	9.64	39.97	57.33	-17.36	QP
0.4260	15.13	9.64	24.77	47.33	-22.56	AVG
0.6380	23.52	9.65	33.17	56.00	-22.83	QP
0.6380	6.98	9.65	16.63	46.00	-29.37	AVG
0.9939	18.25	9.61	27.86	56.00	-28.14	QP
0.9939	4.13	9.61	13.74	46.00	-32.26	AVG
2.3500	18.41	9.53	27.94	56.00	-28.06	QP
2.3500	3.31	9.53	12.84	46.00	-33.16	AVG
3.2299	18.76	9.52	28.28	56.00	-27.72	QP
3.2299	2.62	9.52	12.14	46.00	-33.86	AVG

Remark:

1. All readings are Quasi-Peak and Average values.
2. Factor = Insertion Loss + Cable Loss.

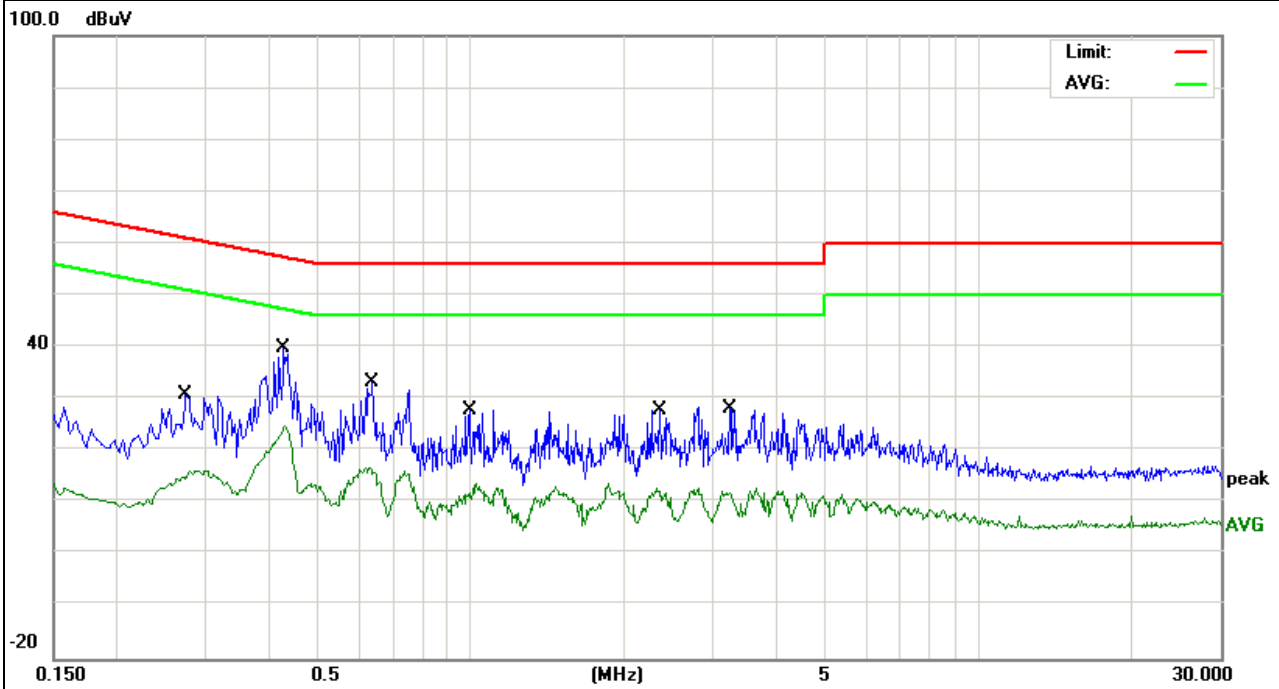

3.2 RADIATED EMISSION MEASUREMENT

3.2.1 RADIATED EMISSION LIMITS (Frequency Range 9kHz-1000MHz)

20dBc in any 100 kHz bandwidth outside the operating frequency band. In case the emission fall within the restricted band specified on 15.205(a), then the 15.209(a) limit in the table below has to be followed.

Frequencies (MHz)	Field Strength (micorvolts/meter)	Measurement Distance (meters)
0.009~0.490	2400/F(KHz)	300
0.490~1.705	24000/F(KHz)	30
1.705~30.0	30	30
30~88	100	3
88~216	150	3
216~960	200	3
Above 960	500	3

LIMITS OF RADIATED EMISSION MEASUREMENT (Above 1000MHz)

FREQUENCY (MHz)	Class B (dBuV/m) (at 3M)	
	PEAK	AVERAGE
Above 1000	74	54

Notes:

- (1) The limit for radiated test was performed according to FCC PART 15C.
- (2) The tighter limit applies at the band edges.
- (3) Emission level (dBuV/m)=20log Emission level (uV/m).

FREQUENCY RANGE OF RADIATED MEASUREMENT (For unintentional radiators)

Highest frequency generated or Upper frequency of measurement used in the device or on which the device operates or tunes (MHz)	Range (MHz)
Below 1.705	30
1.705 – 108	1000
108 – 500	2000
500 – 1000	5000
Above 1000	5 th harmonic of the highest frequency or 40 GHz, whichever is lower

Spectrum Parameter	Setting
Attenuation	Auto
Start Frequency	1000 MHz
Stop Frequency	10th carrier harmonic
RB / VB (emission in restricted band)	1 MHz / 1 MHz for Peak, 1 MHz / 10Hz for Average , PEAK DETECTOR IS USED FOR BOTH

Receiver Parameter	Setting
Attenuation	Auto
Start ~ Stop Frequency	9kHz~150kHz / RB 200Hz for QP
Start ~ Stop Frequency	150kHz~30MHz / RB 9kHz for QP
Start ~ Stop Frequency	30MHz~1000MHz / RB 120kHz for QP

3.2.2 TEST PROCEDURE

- a. The measuring distance of at 3 m shall be used for measurements at frequency up to 1GHz. For frequencies above 1GHz, any suitable measuring distance may be used.
- b. The EUT was placed on the top of a rotating table 0.8 m for below 1GHz and 1.5m for above 1GHz the ground at a 3 meter open area test site. The table was rotated 360 degrees to determine the position of the highest radiation.
- c. The height of the equipment or of the substitution antenna shall be 0.8 m for below 1GHz and 1.5m for above 1GHz; the height of the test antenna shall vary between 1 m to 4 m. Both horizontal and vertical polarizations of the antenna are set to make the measurement.
- d. The initial step in collecting conducted emission data is a spectrum analyzer peak detector mode pre-scanning the measurement frequency range. Significant peaks are then marked and then Quasi Peak detector mode re-measured.
- e. If the Peak Mode measured value compliance with and lower than Quasi Peak Mode Limit, the EUT shall be deemed to meet QP Limits and then no additional QP Mode measurement performed.
- f. For the actual test configuration, please refer to the related Item –EUT Test Photos.

Note:

Both horizontal and vertical antenna polarities were tested and performed pretest to three orthogonal axis. The worst case emissions were reported

3.2.3 DEVIATION FROM TEST STANDARD

No deviation

3.2.4 TEST SETUP

(A) Radiated Emission Test-Up Frequency Below 30MHz

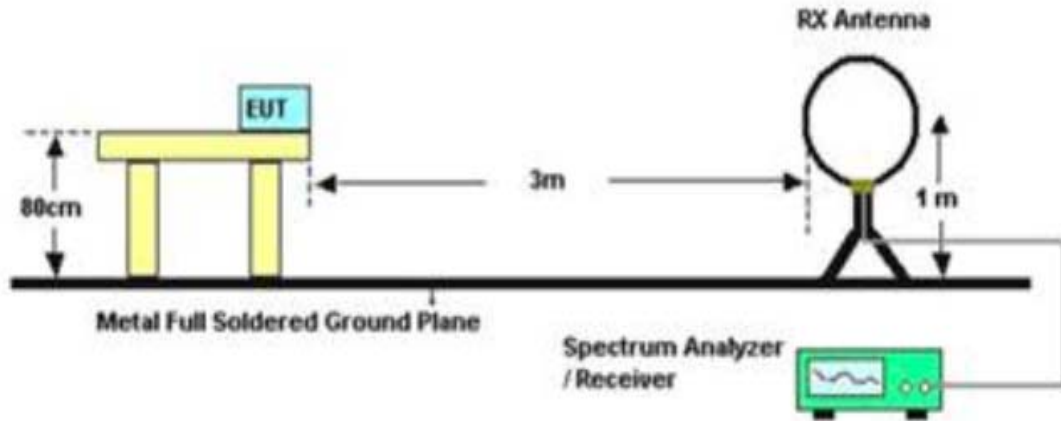

(B) Radiated Emission Test-Up Frequency 30MHz~1GHz

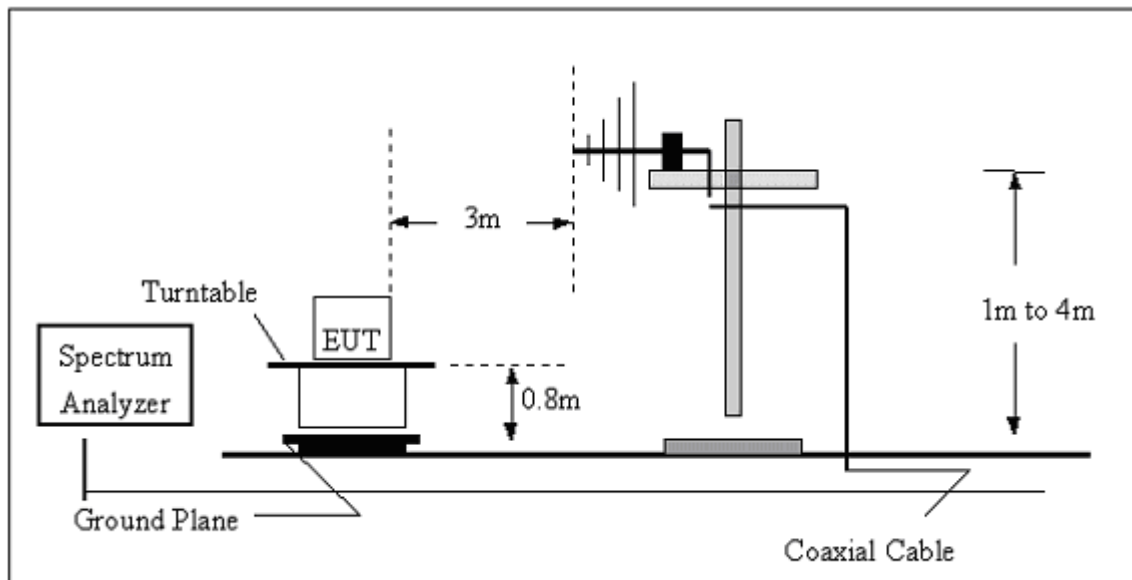

(C) Radiated Emission Test-Up Frequency Above 1GHz

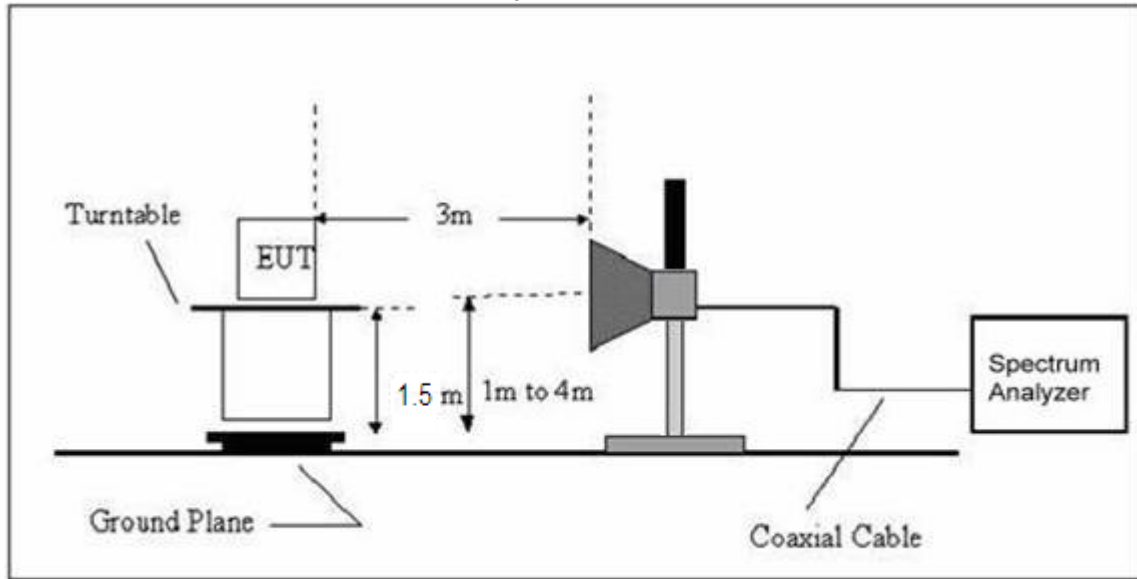

3.2.5 EUT OPERATING CONDITIONS

The EUT tested system was configured as the statements of 2.4 Unless otherwise a special operating condition is specified in the follows during the testing.

3.2.6 TEST RESULTS (BELOW 30 MHZ)

EUT :	Sacool Pro	Model Name :	BTHS-AS8P
Temperature :	20 °C	Relative Humidity :	48%
Pressure :	1010 hPa	Test Voltage :	DC 3.7V
Test Mode :	TX	Polarization :	---

Freq.	Reading	Limit	Margin	State
(MHz)	(dBuV/m)	(dBuV/m)	(dB)	P/F
--	--	--	--	Pass
--	--	--	--	Pass

NOTE:

The amplitude of spurious emissions which are attenuated by more than 20dB below the permissible value has no need to be reported.

Distance extrapolation factor = $20 \log (\text{specific distance}/\text{test distance})$ (dB);

Limit line = specific limits(dBuV) + distance extrapolation factor.

3.2.7 TEST RESULTS (BETWEEN 30M – 1000 MHZ)

EUT :	Sacool Pro	Model Name :	BTHS-AS8P
Temperature :	20 °C	Relative Humidity :	48%
Pressure :	1010hPa	Test Mode :	TX
Test Voltage :	DC 3.7V		

Polar (H/V)	Frequency	Meter Reading	Factor	Emission Level	Limits	Margin	Remark
	(MHz)	(dBuV)	(dB)	(dBuV/m)	(dBuV/m)	(dB)	
V	31.9542	7.52	18.36	25.88	40.00	-14.12	QP
V	63.3132	15.25	7.08	22.33	40.00	-17.67	QP
V	119.4360	7.87	11.98	19.85	43.50	-23.65	QP
V	162.0413	10.80	10.50	21.30	43.50	-22.20	QP
V	472.1759	12.16	19.74	31.90	46.00	-14.10	QP
V	779.6067	8.40	26.88	35.28	46.00	-10.72	QP

Remark:

Absolute Level= ReadingLevel+ Factor, Margin= Absolute Level - Limit

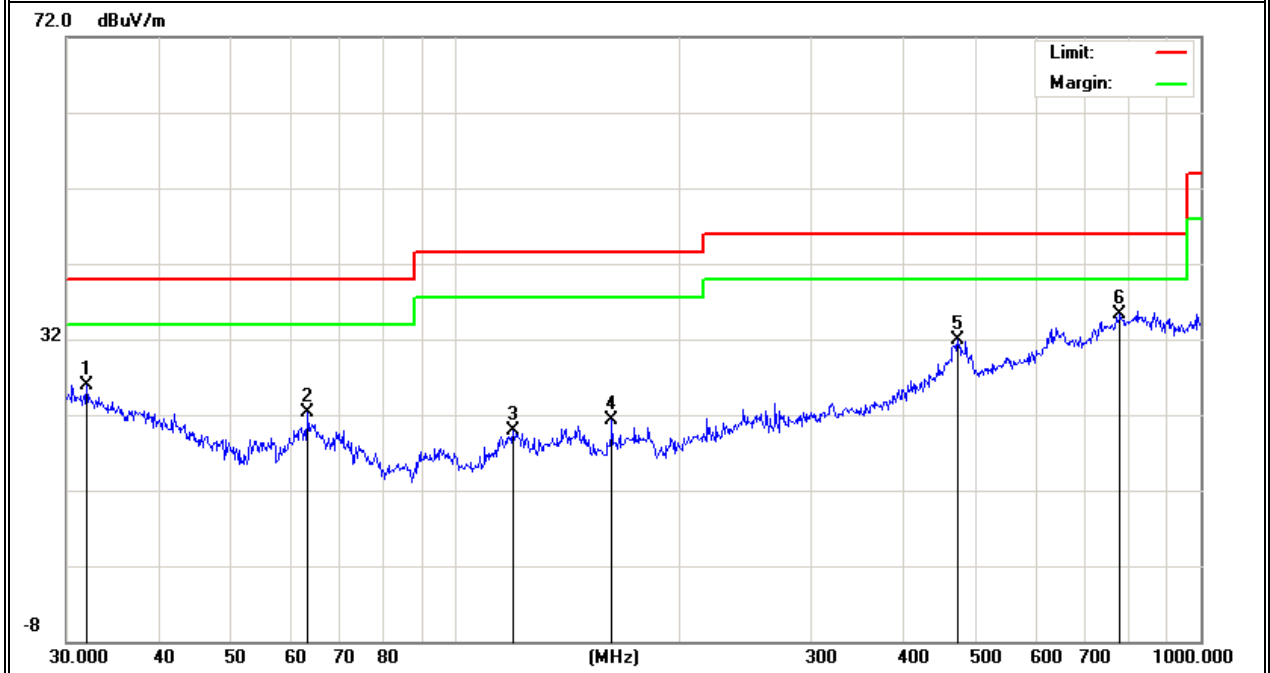

Polar (H/V)	Frequency	Meter Reading	Factor	Emission Level	Limits	Margin	Remark
	(MHz)	(dBuV)	(dB)	(dBuV/m)	(dBuV/m)	(dB)	
H	32.7486	8.68	17.92	26.60	40.00	-13.40	QP
H	119.0177	6.04	11.88	17.92	43.50	-25.58	QP
H	272.2776	20.93	13.84	34.77	46.00	-11.23	QP
H	324.4560	16.32	15.18	31.50	46.00	-14.50	QP
H	440.1961	17.87	19.11	36.98	46.00	-9.02	QP
H	752.7431	9.46	26.17	35.63	46.00	-10.37	QP

Remark:

Absolute Level= ReadingLevel+ Factor, Margin= Absolute Level - Limit

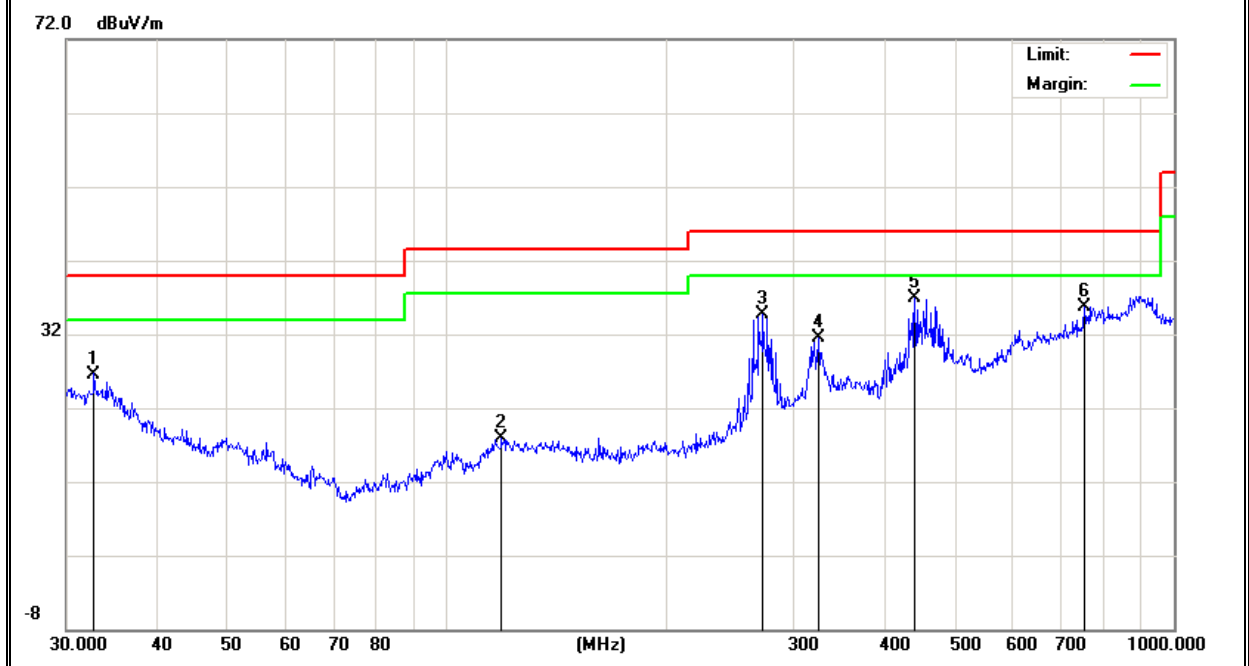

3.2.8 TEST RESULTS (ABOVE 1000 MHZ)

EUT :	Sacool Pro	Model Name :	BTHS-AS8P
Temperature :	20 °C	Relative Humidity :	48%
Pressure :	1010hPa	Test Mode :	TX
Test Mode :	DC 3.7V		

Frequency (MHz)	Meter Reading (dBµV)	Factor (dB)	Emission Level (dBµV/m)	Limits (dBµV/m)	Margin (dB)	Remark	Comment
Low Channel (2402 MHz)-Above 1G							
4803.894	61.25	-3.64	57.61	74.00	-16.39	Pk	Vertical
4803.894	49.66	-3.64	46.02	54.00	-7.98	AV	Vertical
7206.162	57.34	-0.95	56.39	74.00	-17.61	Pk	Vertical
7206.162	42.65	-0.95	41.70	54.00	-12.30	AV	Vertical
4804.194	65.99	-3.64	62.35	74.00	-11.65	Pk	Horizontal
4804.194	49.29	-3.64	45.65	54.00	-8.35	AV	Horizontal
7206.773	60.03	-0.96	59.07	74.00	-14.93	Pk	Horizontal
7206.773	46.21	-0.96	45.25	54.00	-8.75	AV	Horizontal
Mid Channel (2441 MHz)-Above 1G							
4882.091	64.97	-3.67	61.30	74.00	-12.70	Pk	Vertical
4882.091	47.87	-3.67	44.20	54.00	-9.80	AV	Vertical
7323.266	56.42	-0.82	55.60	74.00	-18.40	Pk	Vertical
7323.266	45.39	-0.82	44.57	54.00	-9.43	AV	Vertical
4882.638	63.57	-3.67	59.90	74.00	-14.10	Pk	Horizontal
4882.638	46.23	-3.67	42.56	54.00	-11.44	AV	Horizontal
7323.304	60.07	-0.82	59.25	74.00	-14.75	Pk	Horizontal
7323.304	45.50	-0.82	44.68	54.00	-9.32	AV	Horizontal
High Channel (2480 MHz)- Above 1G							
4960.283	60.24	-3.59	56.65	74.00	-17.35	Pk	Vertical
4960.283	45.69	-3.59	42.10	54.00	-11.90	AV	Vertical
7440.347	54.71	-0.68	54.03	74.00	-19.97	Pk	Vertical
7440.347	43.68	-0.68	43.00	54.00	-11.00	AV	Vertical
4960.804	61.06	-3.59	57.47	74.00	-16.53	Pk	Horizontal
4960.804	48.68	-3.59	45.09	54.00	-8.91	AV	Horizontal
7440.397	61.48	-0.68	60.80	74.00	-13.20	Pk	Horizontal
7440.397	46.31	-0.68	45.63	54.00	-8.37	AV	Horizontal

Remark: GFSK ,8DPSK ,Pi/4DQPSK all have been tested ,GFSK mode is found as the worst case and only reported.

Factor = Antenna Factor + Cable Loss – Pre-amplifier.

Emission Level = Reading + Factor

Margin = Emission Level- Limit

Radiated band edge:

Channel	Frequency (MHz)	Meter Reading (dBμV)	Factor (dB)	Emission Level (dBμV/m)	Limits (dBμV/m)	Margin (dB)	Detector Type	Comment
GFSK Non-hopping								
CH00	2390	66.95	-13.06	53.89	74	-20.11	peak	Vertical
	2390	63.97	-13.06	50.91	74	-23.09	peak	Horizontal
CH78	2483.5	65.15	-12.78	52.37	74	-21.63	peak	Vertical
	2483.5	63.07	-12.78	50.29	74	-23.71	peak	Horizontal
GFSK hopping								
CH00~ CH78	2390	66.3	-13.06	53.24	74	-20.76	peak	Vertical
	2390	62.34	-13.06	49.28	74	-24.72	peak	Horizontal
	2483.5	61.44	-12.78	48.66	74	-25.34	peak	Vertical
	2483.5	60.74	-12.78	47.96	74	-26.04	peak	Horizontal
π/4-DQPSK Non-hopping								
CH00	2390	62.18	-13.06	49.12	74	-24.88	peak	Vertical
	2390	63.05	-13.06	49.99	74	-24.01	peak	Horizontal
CH78	2483.5	64.86	-12.78	52.08	74	-21.92	peak	Vertical
	2483.5	61.11	-12.78	48.33	74	-25.67	peak	Horizontal
π/4-DQPSK hopping								
CH00~ CH78	2390	63.59	-13.06	50.53	74	-23.47	peak	Vertical
	2390	62.84	-13.06	49.78	74	-24.22	peak	Horizontal
	2483.5	65.97	-12.78	53.19	74	-20.81	peak	Vertical
	2483.5	58.96	-12.78	46.18	74	-27.82	peak	Horizontal
8-DPSK Non-hopping								
CH00	2390	63.07	-13.06	50.01	74	-23.99	peak	Vertical
	2390	64.58	-13.06	51.52	74	-22.48	peak	Horizontal
CH78	2483.5	66.91	-12.78	54.13	74	-19.87	peak	Vertical
	2483.5	48.76	-12.78	35.98	54	-18.02	Avg	Vertical
	2483.5	65.91	-12.78	53.13	74	-20.87	peak	Horizontal
8-DPSK hopping								
CH00~ CH78	2390	63.33	-13.06	50.27	74	-23.73	peak	Vertical
	2390	61.4	-13.06	48.34	74	-25.66	peak	Horizontal
	2483.5	63.28	-12.78	50.5	74	-23.5	peak	Vertical
	2483.5	65.19	-12.78	52.41	74	-21.59	peak	Horizontal

Note: When PK value is lower than the Average value limit, average didn't record.

4. NUMBER OF HOPPING CHANNEL

4.1 APPLIED PROCEDURES / LIMIT

FCC Part15 (15.247) , Subpart C				
Section	Test Item	Limit	Frequency Range (MHz)	Result
15.247 (a)(1)(iii)	Number of Hopping Channel	≥15	2400-2483.5	PASS

Spectrum Parameters	Setting
Attenuation	Auto
Span Frequency	= the frequency band of operation
RB	RBW=100kHz
VB	VBW ≥ RBW
Detector	Peak
Trace	Max Hold
Sweep Time	Auto

4.1.1 TEST PROCEDURE

- a. The EUT was directly connected to the spectrum analyzer and antenna output port as show in the block diagram below,
- b. Spectrum Setting : RBW= 100kHz, VBW=100kHz, Sweep time = Auto.

4.1.2 DEVIATION FROM STANDARD

No deviation.

4.1.3 TEST SETUP



4.1.4 EUT OPERATION CONDITIONS

The EUT tested system was configured as the statements of 2.4 Unless otherwise a special operating condition is specified in the follows during the testing.

4.1.5 TEST RESULTS

EUT :	Sacool Pro	Model Name :	BTHS-AS8P
Temperature :	25 °C	Relative Humidity :	60%
Pressure :	1015 hPa	Test Voltage :	DC 3.7V
Test Mode :	Hopping Mode-GFSK		

Number of Hopping Channel	79
---------------------------	----

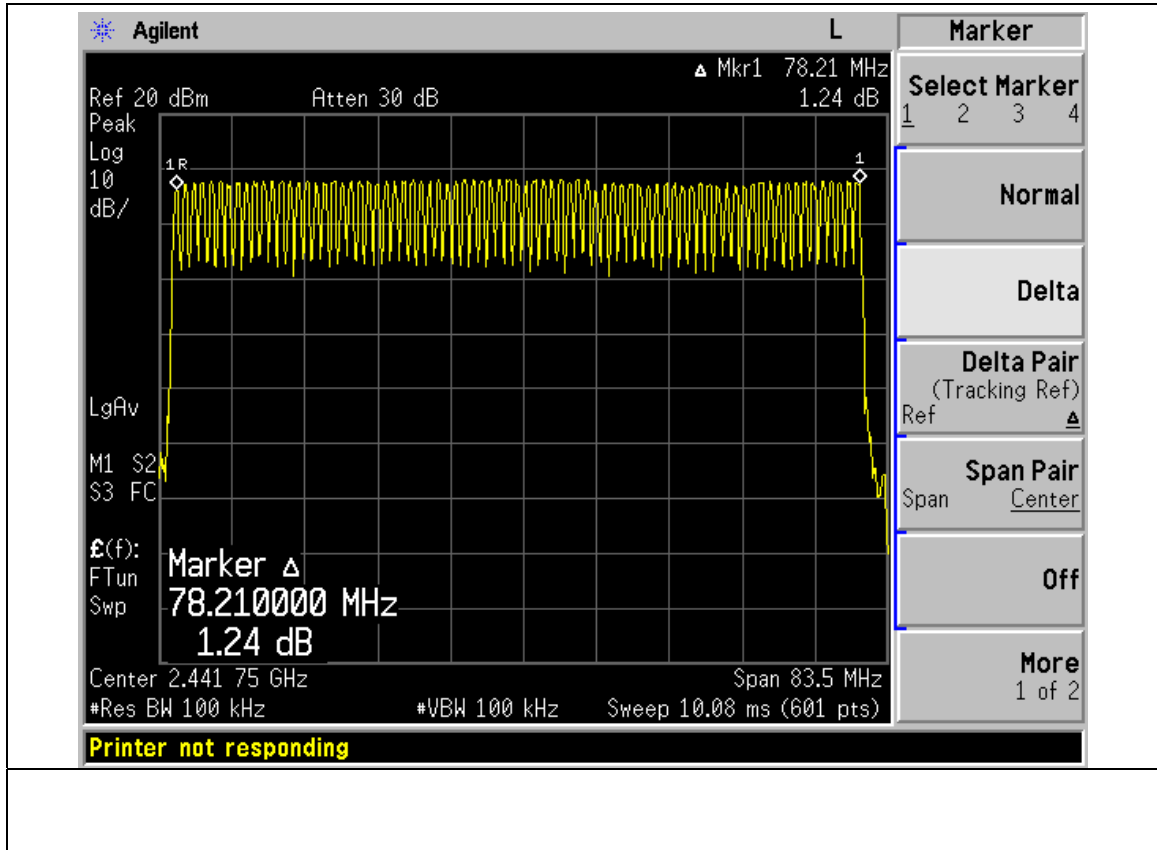

5. AVERAGE TIME OF OCCUPANCY

5.1 APPLIED PROCEDURES / LIMIT

FCC Part15 (15.247) , Subpart C				
Section	Test Item	Limit	Frequency Range (MHz)	Result
15.247 (a)(1)(iii)	Average Time of Occupancy	0.4sec	2400-2483.5	PASS

5.1.1 TEST PROCEDURE

- a. The transmitter output (antenna port) was connected to the spectrum analyzer
- b. Set RBW of spectrum analyzer to 1MHz and VBW to 1MHz.
- c. Use a video trigger with the trigger level set to enable triggering only on full pulses.
- d. Sweep Time is more than once pulse time.
- e. Set the center frequency on any frequency would be measure and set the frequency span to zero span.
- f. Measure the maximum time duration of one single pulse.
- g. Set the EUT for DH5, DH3 and DH1 packet transmitting.
- h. Measure the maximum time duration of one single pulse.
- i. A Period Time = (channel number)*0.4
 DH1 Time Slot: Reading * (1600/2)*31.6/(channel number)
 DH3 Time Slot: Reading * (1600/4)*31.6/(channel number)
 DH5 Time Slot: Reading * (1600/6)*31.6/(channel number)

5.1.2 DEVIATION FROM STANDARD

No deviation.

5.1.3 TEST SETUP

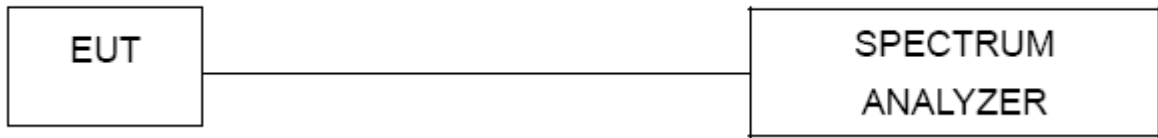

5.1.4 EUT OPERATION CONDITIONS

The EUT tested system was configured as the statements of 2.4 Unless otherwise a special operating condition is specified in the follows during the testing.

5.1.5 TEST RESULTS

EUT :	Sacool Pro	Model Name :	BTHS-AS8P
Temperature :	25 °C	Relative Humidity :	60%
Pressure :	1012 hPa	Test Voltage :	DC 3.7V
Test Mode :	CH39-DH5 ,2DH5,3DH5		

Data Packet	Frequency	Pulse Duration	Dwell Time	Limits
		(ms)	(s)	(s)
DH5	2441 MHz	2.94	0.31	0.4
2DH5	2441 MHz	2.96	0.32	0.4
3DH5	2441 MHz	2.95	0.31	0.4

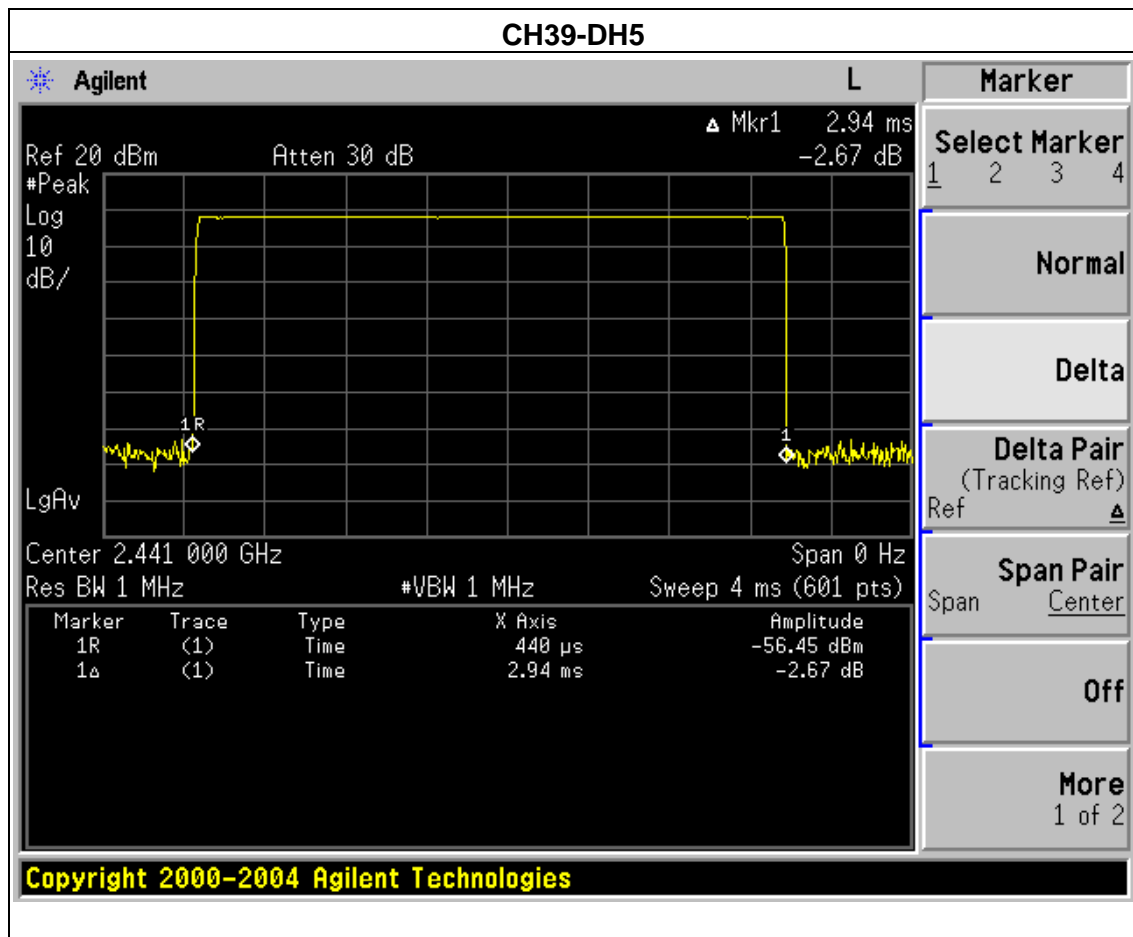

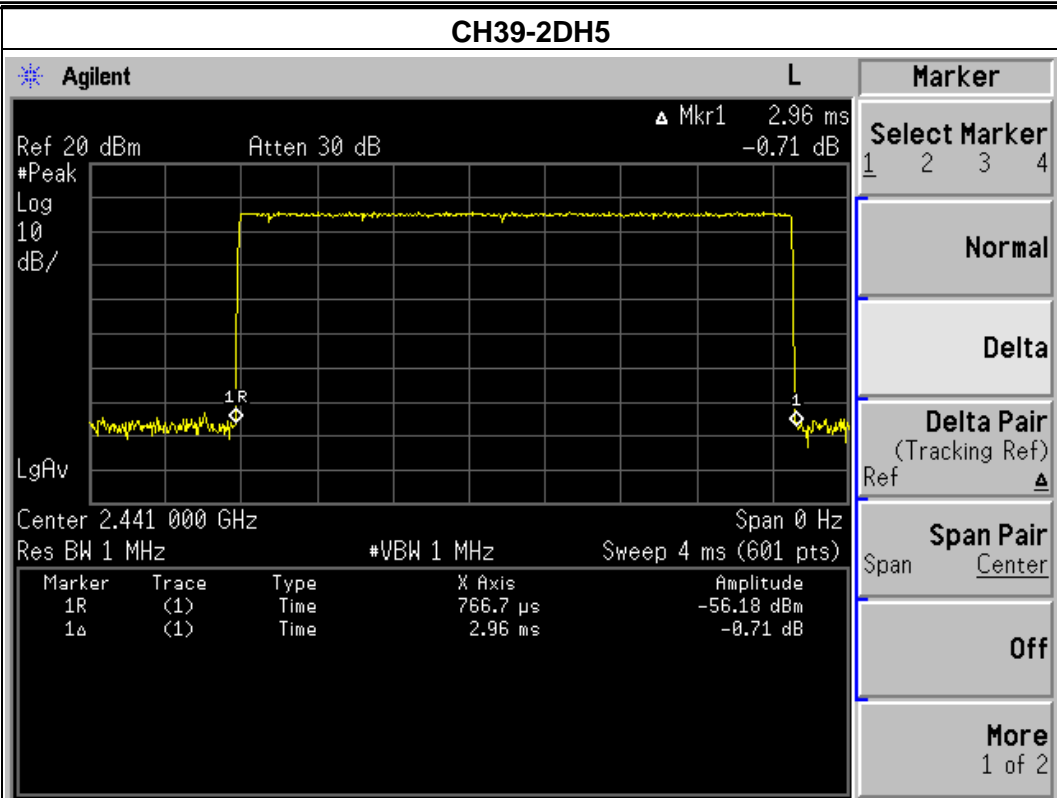

Copyright 2000-2004 Agilent Technologies

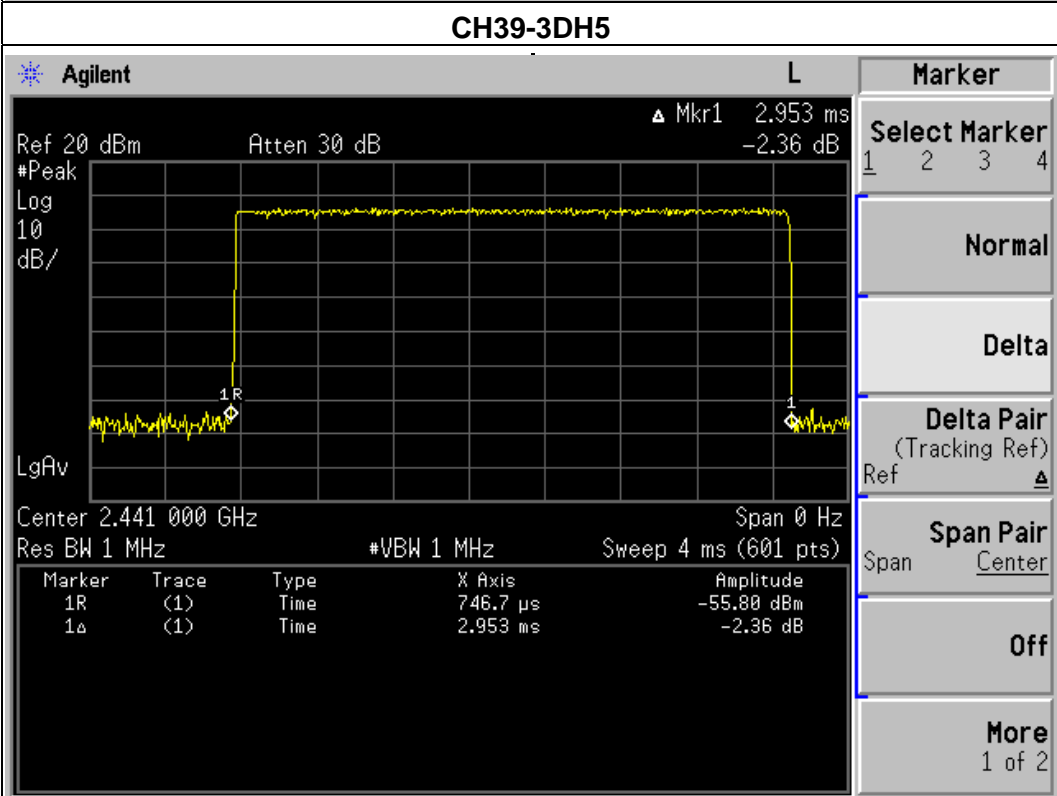

Copyright 2000-2004 Agilent Technologies

EUT :	Sacool Pro	Model Name :	BTHS-AS8P
Temperature :	25 °C	Relative Humidity :	60%
Pressure :	1012 hPa	Test Voltage :	DC 3.7V
Test Mode :	CH39-DH3,2DH3,3DH3		

Data Packet	Frequency	Pulse Duration	Dwell Time	Limits
		(ms)	(s)	(s)
DH3	2441 MHz	1.70	0.27	0.4
2DH3	2441 MHz	1.72	0.28	0.4
3DH3	2441 MHz	1.70	0.27	0.4

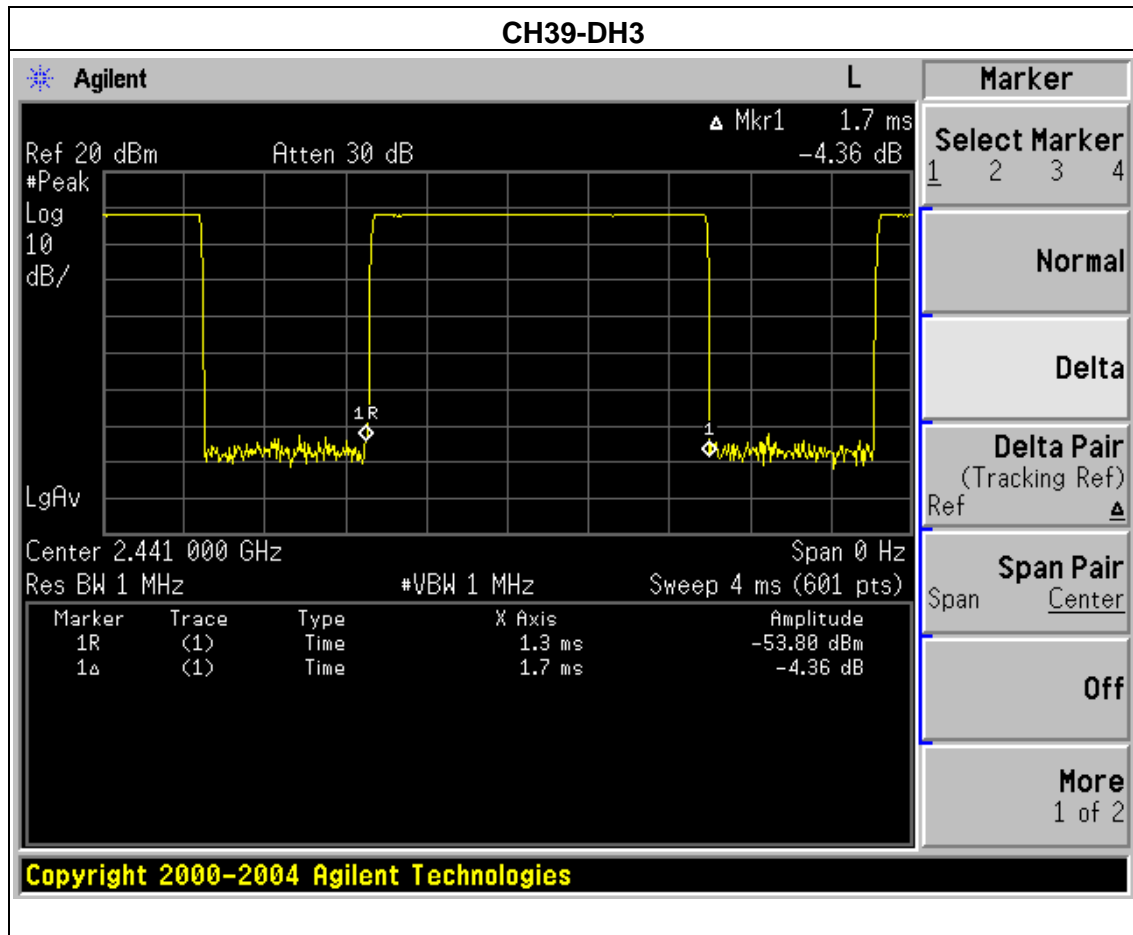

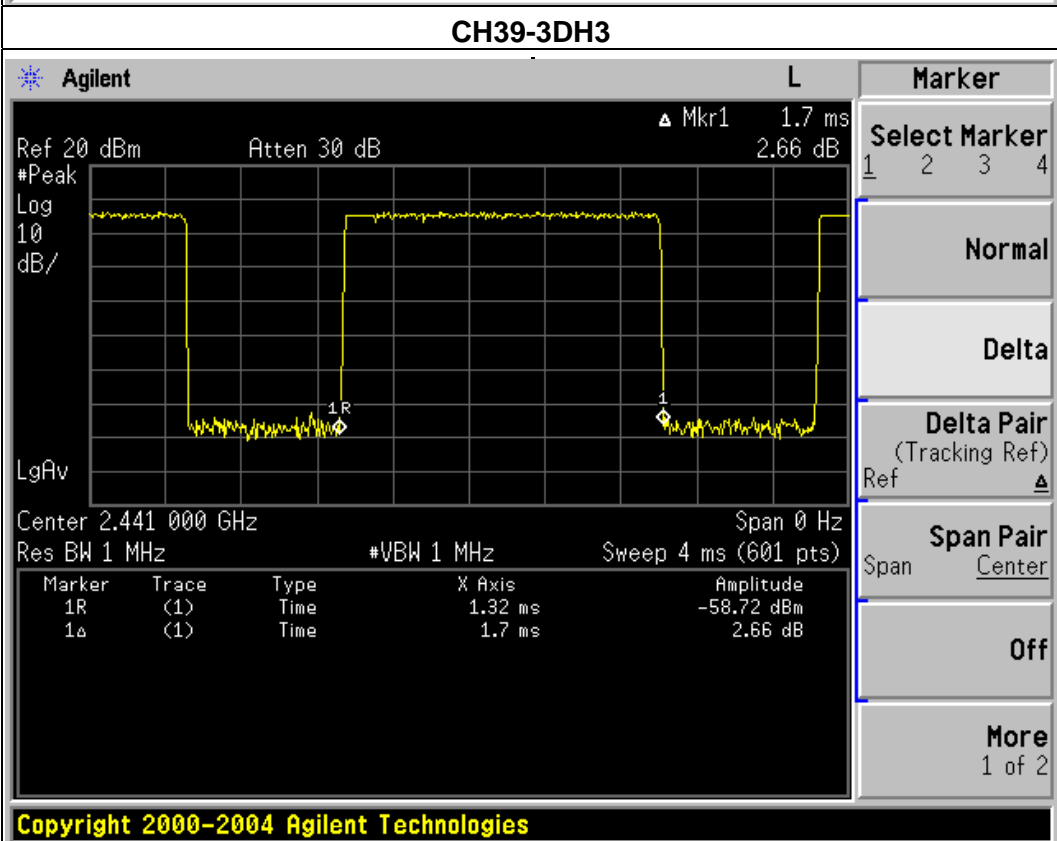
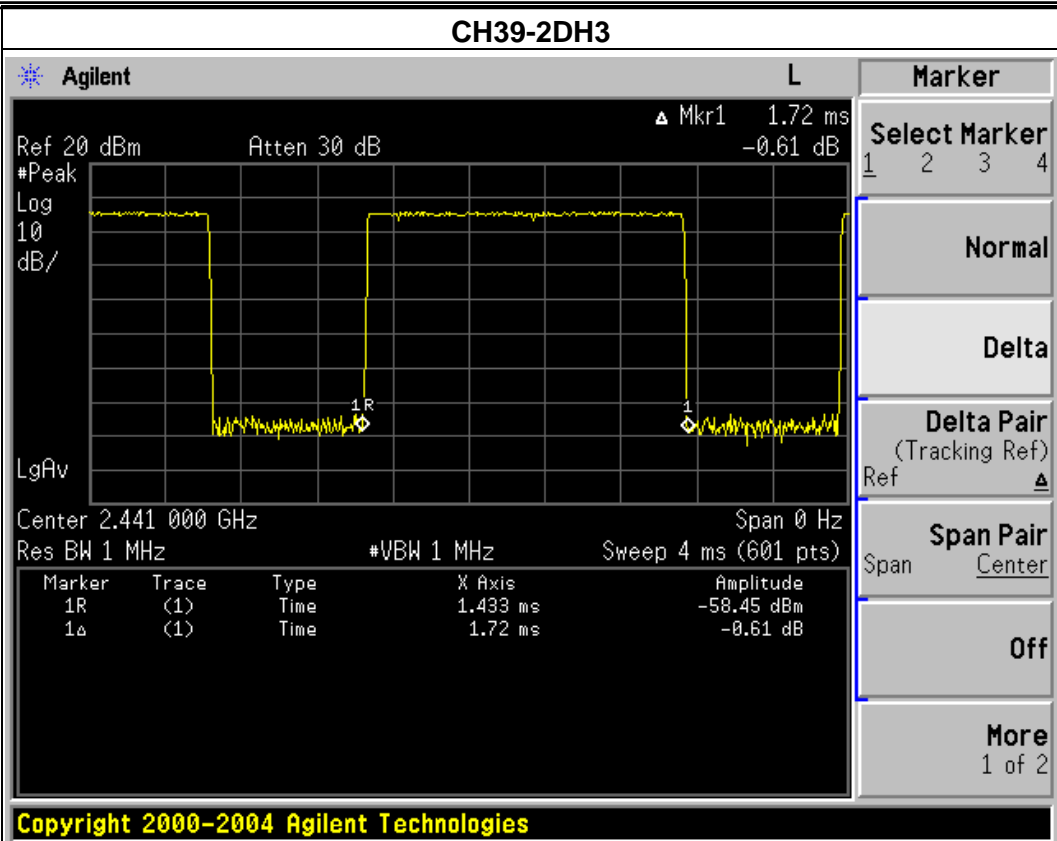

EUT :	Sacool Pro	Model Name :	BTHS-AS8P
Temperature :	25 °C	Relative Humidity :	60%
Pressure :	1012 hPa	Test Voltage :	DC 3.7V
Test Mode :	CH39-DH1,2DH1,3DH1		

Data Packet	Frequency	Pulse Duration	Dwell Time	Limits
		(ms)	(s)	(s)
DH1	2441 MHz	0.45	0.14	0.4
2DH1	2441 MHz	0.45	0.14	0.4
3DH1	2441 MHz	0.47	0.15	0.4

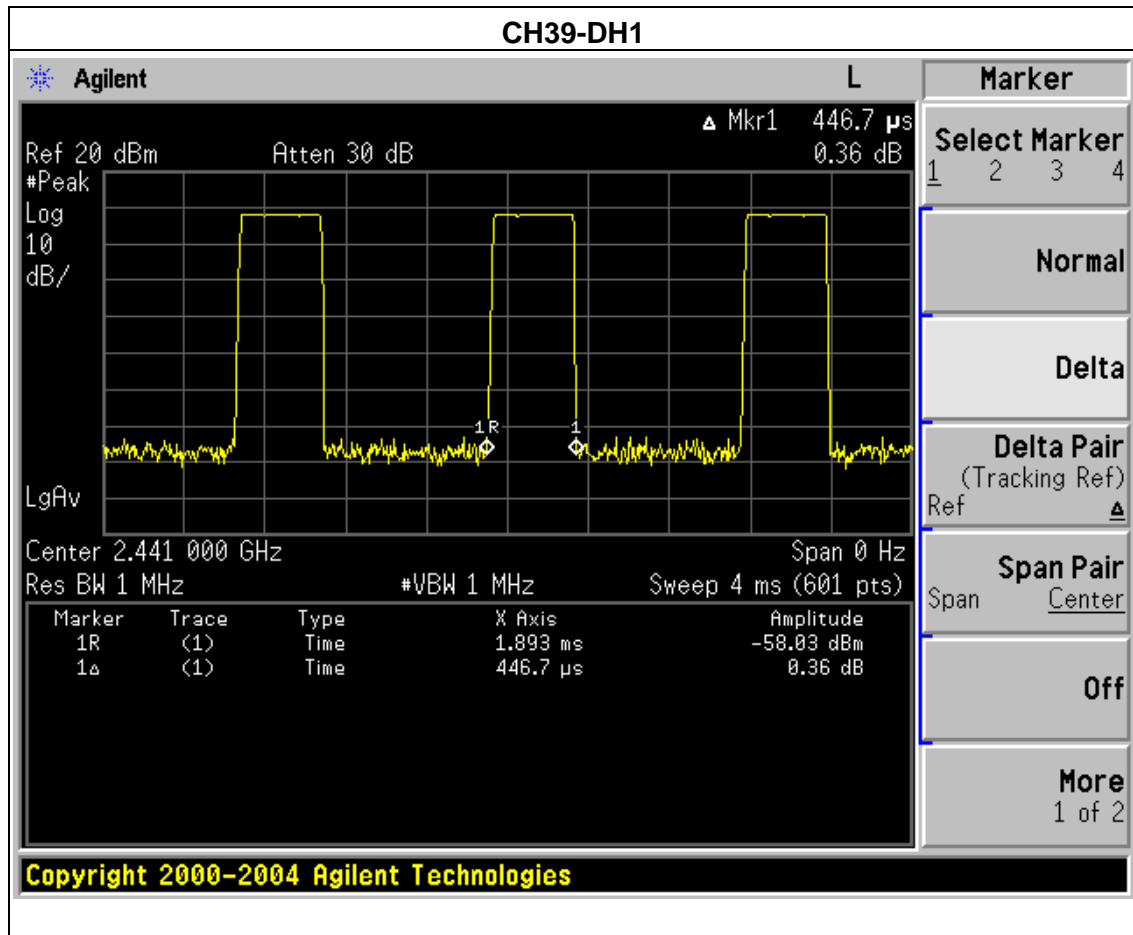

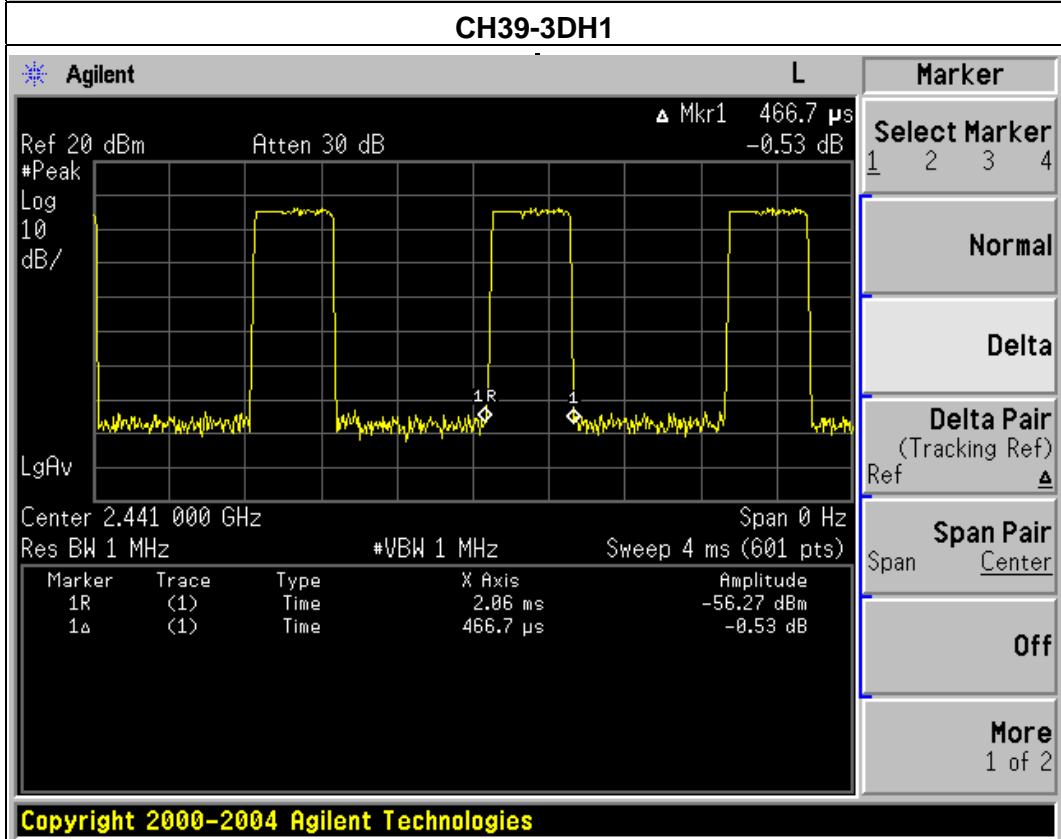
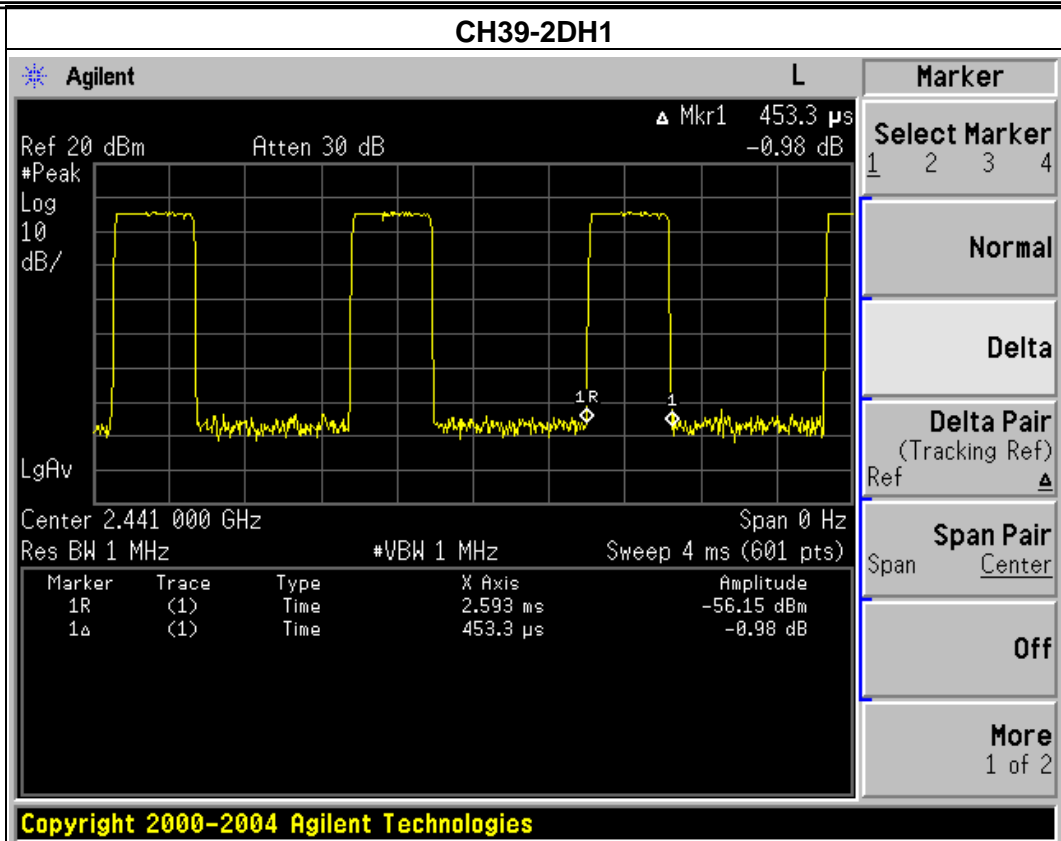

6. HOPPING CHANNEL SEPARATION MEASUREMENT

6.1 APPLIED PROCEDURES / LIMIT

Frequency hopping systems operating in the 2400-2483.5 MHz band may have hopping channel carrier frequencies that are separated by 25 kHz or two-thirds of the 20 dB bandwidth of the hopping channel, whichever is greater.

Spectrum Parameter	Setting
Attenuation	Auto
Span Frequency	> Measurement Bandwidth or Channel Separation
RB	30 kHz (Channel Separation)
VB	100 kHz (Channel Separation)
Detector	Peak
Trace	Max Hold
Sweep Time	Auto

6.1.1 TEST PROCEDURE

- a. The transmitter output (antenna port) was connected to the spectrum analyser in peak hold mode.
- b. The resolution bandwidth of 30 kHz and the video bandwidth of 100 kHz were utilised for channel separation measurement.

6.1.2 DEVIATION FROM STANDARD

No deviation.

6.1.3 TEST SETUP

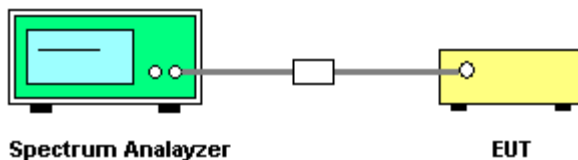

6.1.4 EUT OPERATION CONDITIONS

The EUT was programmed to be in continuously transmitting mode.

6.1.5 TEST RESULTS

EUT :	Sacool Pro	Model Name :	BTHS-AS8P
Temperature :	25 °C	Relative Humidity :	60%
Pressure :	1012 hPa	Test Voltage :	DC 3.7V
Test Mode :	CH00 / CH39 /CH78 (GFSK Mode)		

Frequency	Ch. Separation (MHz)	Result
2402 MHz	1.003	Complies
2441 MHz	1.003	Complies
2480 MHz	1.003	Complies

Ch. Separation Limits: > 20dB bandwidth

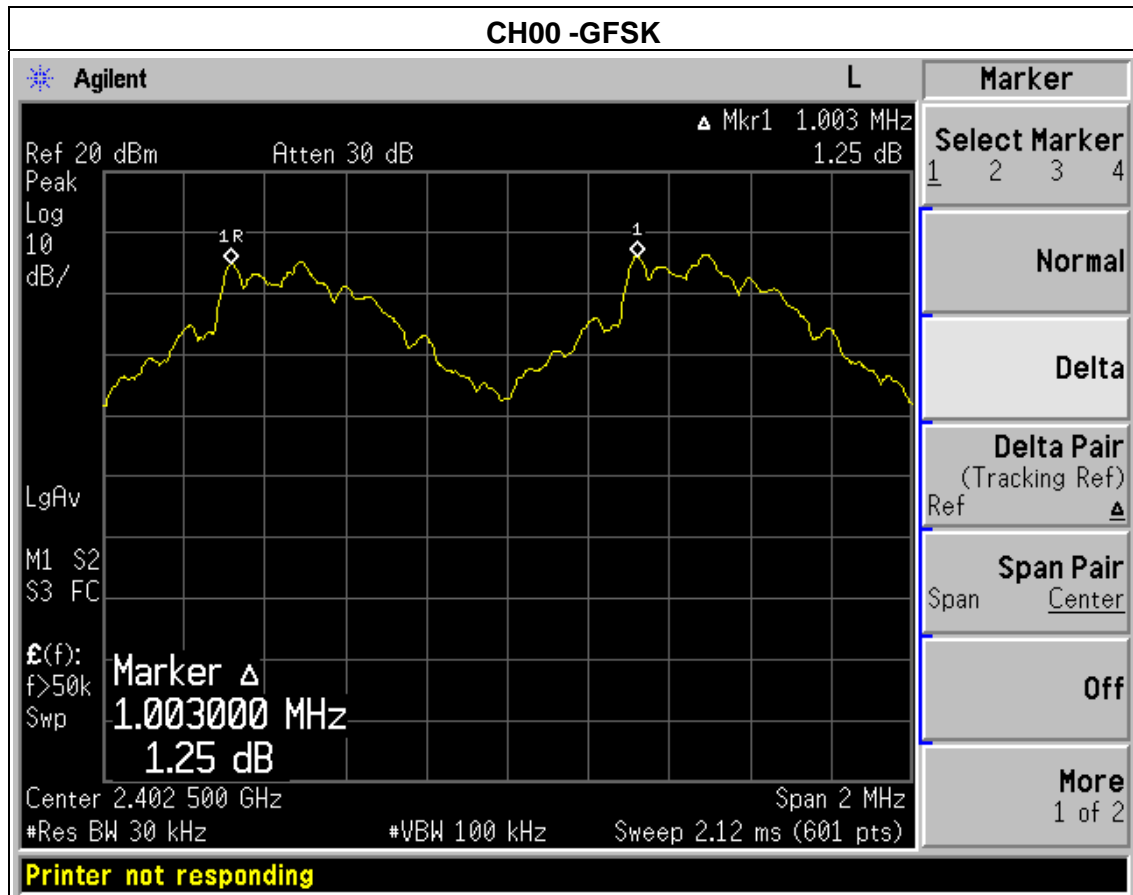

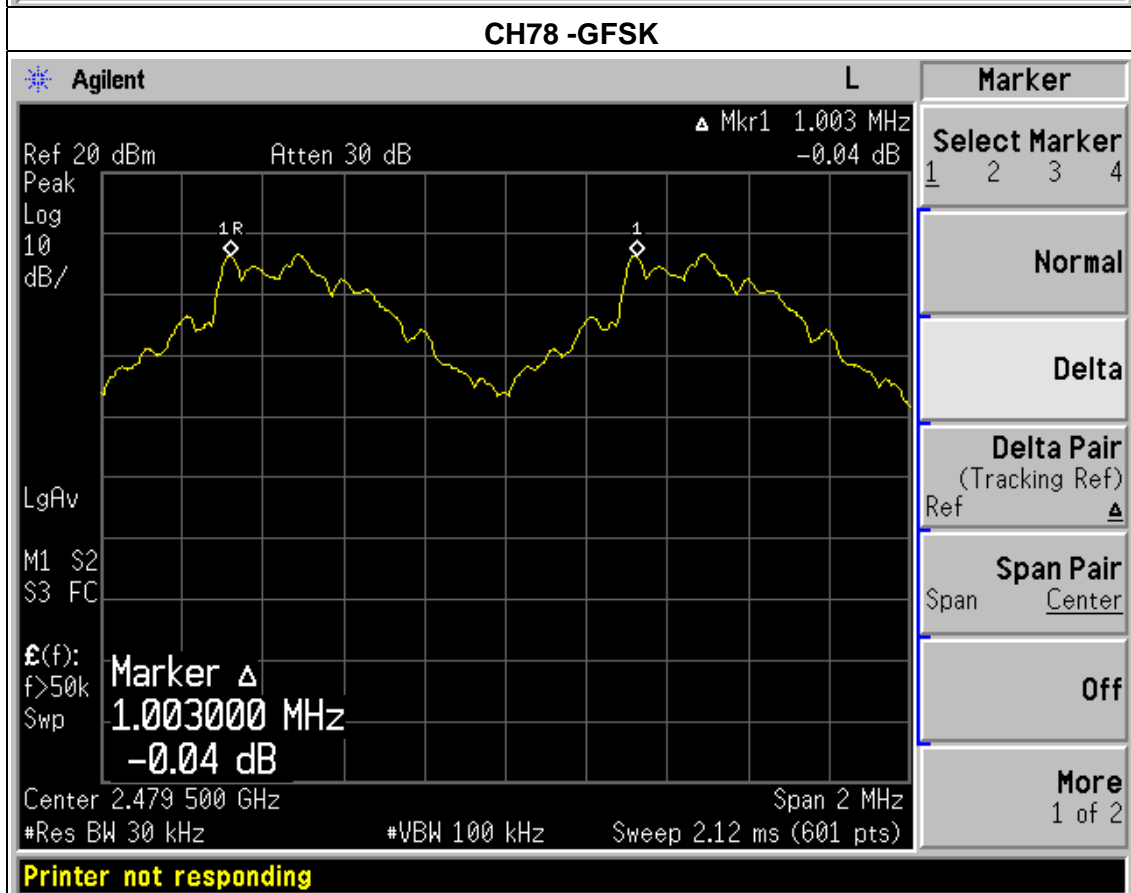
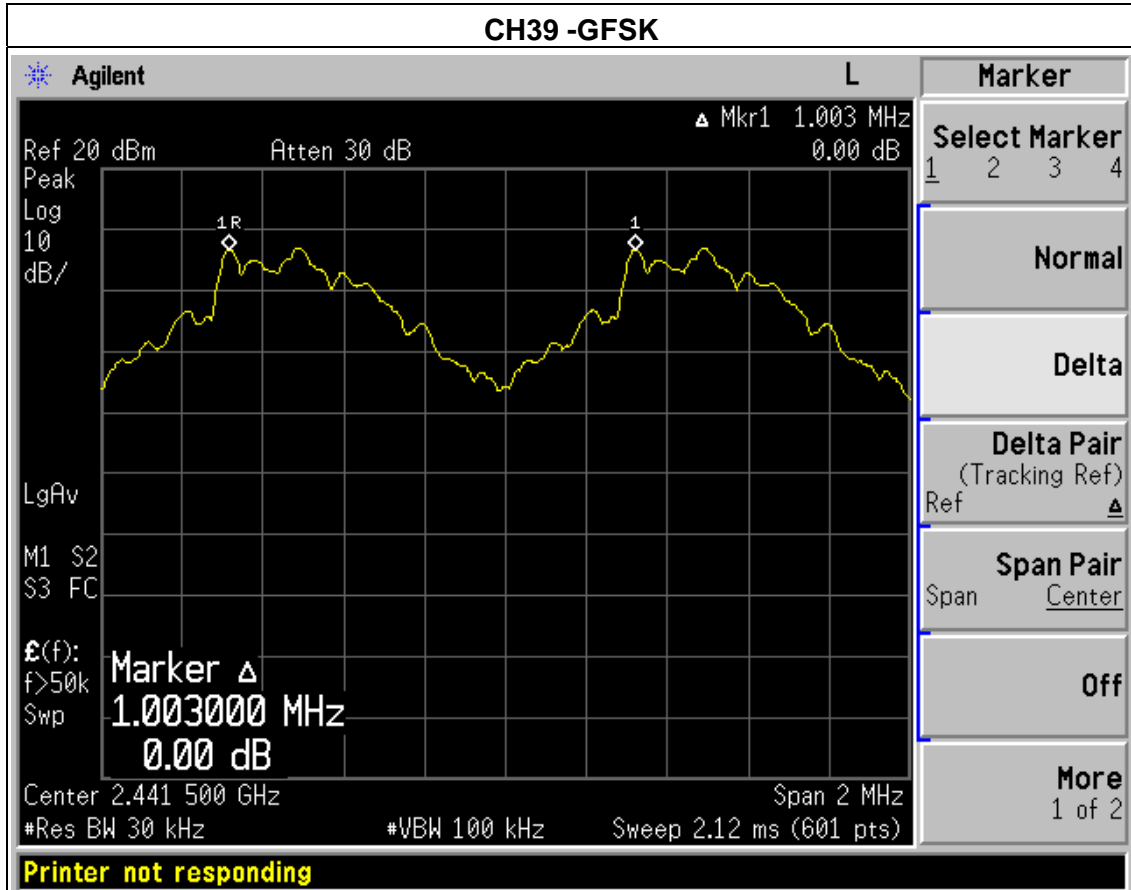

EUT :	Sacool Pro	Model Name :	BTHS-AS8P
Temperature :	25 °C	Relative Humidity :	60%
Pressure :	1012 hPa	Test Voltage :	DC 3.7V
Test Mode :	CH00 / CH39 /CH78 ($\pi/4$ -DQPSK Mode)		

Frequency	Ch. Separation (MHz)	Result
2402 MHz	1.004	Complies
2441 MHz	1.004	Complies
2480 MHz	1.008	Complies

Ch. Separation Limits: >2/3 of 20dB bandwidth

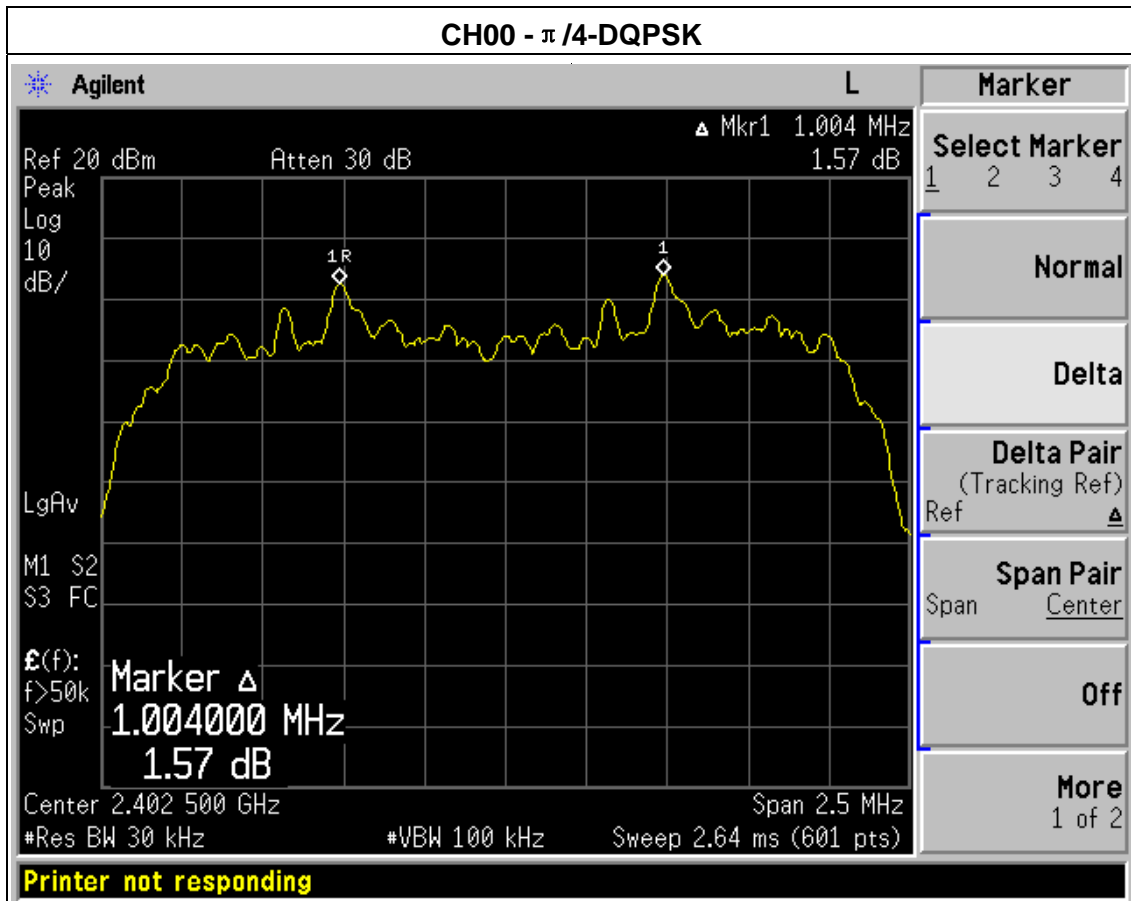

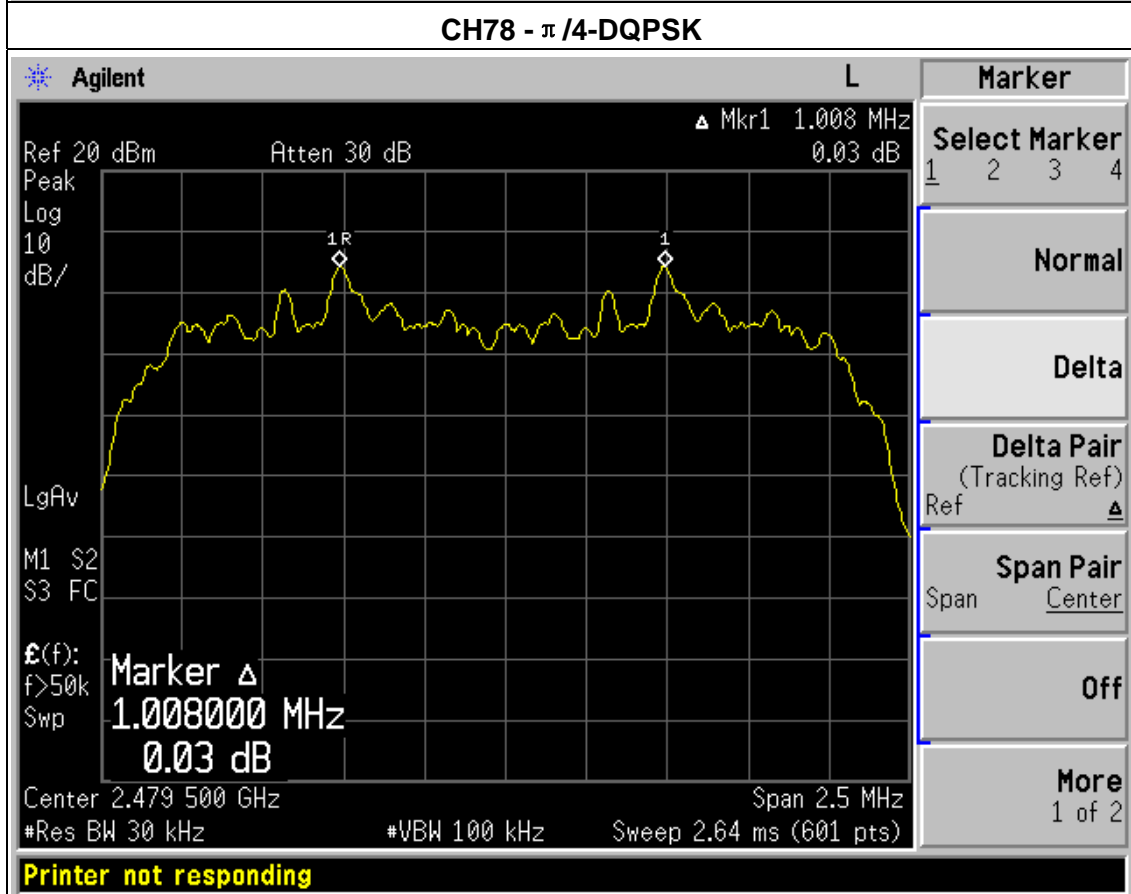
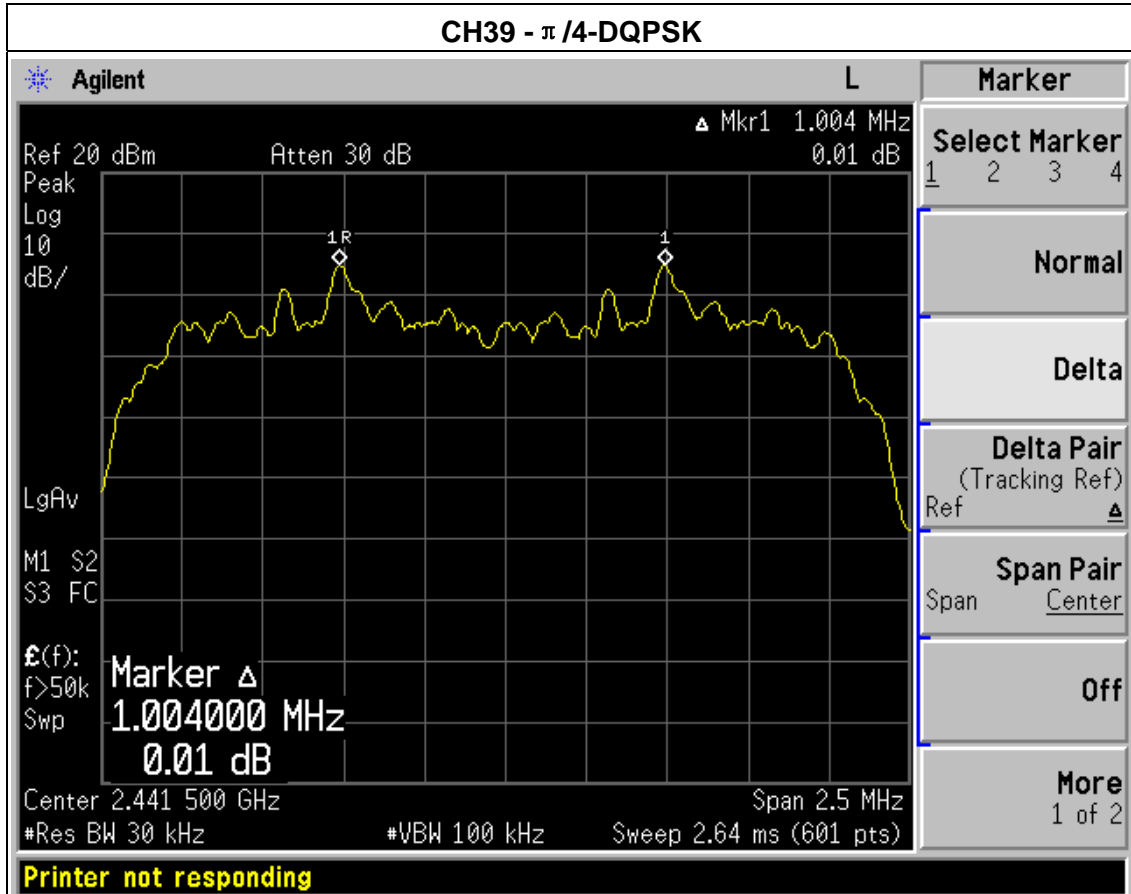

EUT :	Sacool Pro	Model Name :	BTHS-AS8P
Temperature :	25 °C	Relative Humidity :	60%
Pressure :	1012 hPa	Test Voltage :	DC 3.7V
Test Mode :	CH00 / CH39 /CH78 (8-DPSK Mode)		

Frequency	Ch. Separation (MHz)	Result
2402 MHz	1.004	Complies
2441 MHz	1.012	Complies
2480 MHz	1.004	Complies

Ch. Separation Limits: >2/3 of 20dB bandwidth

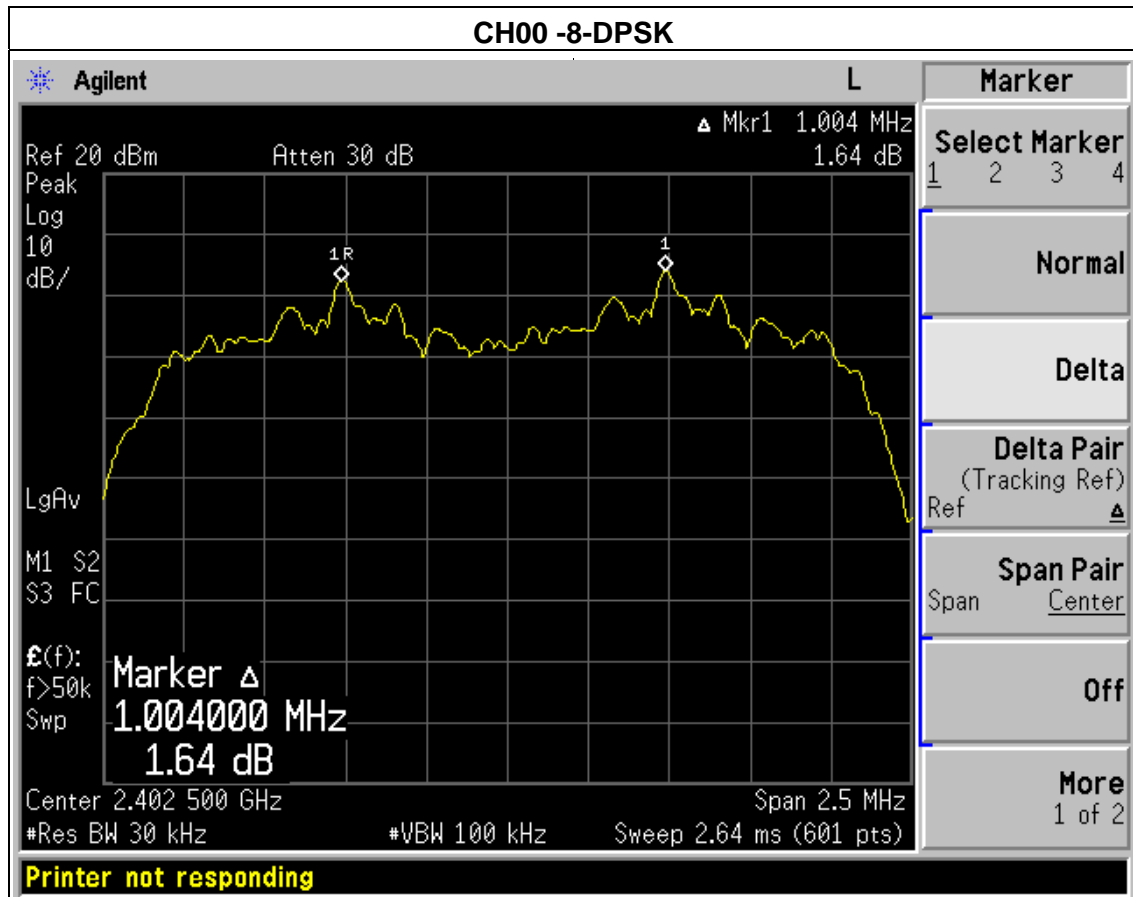

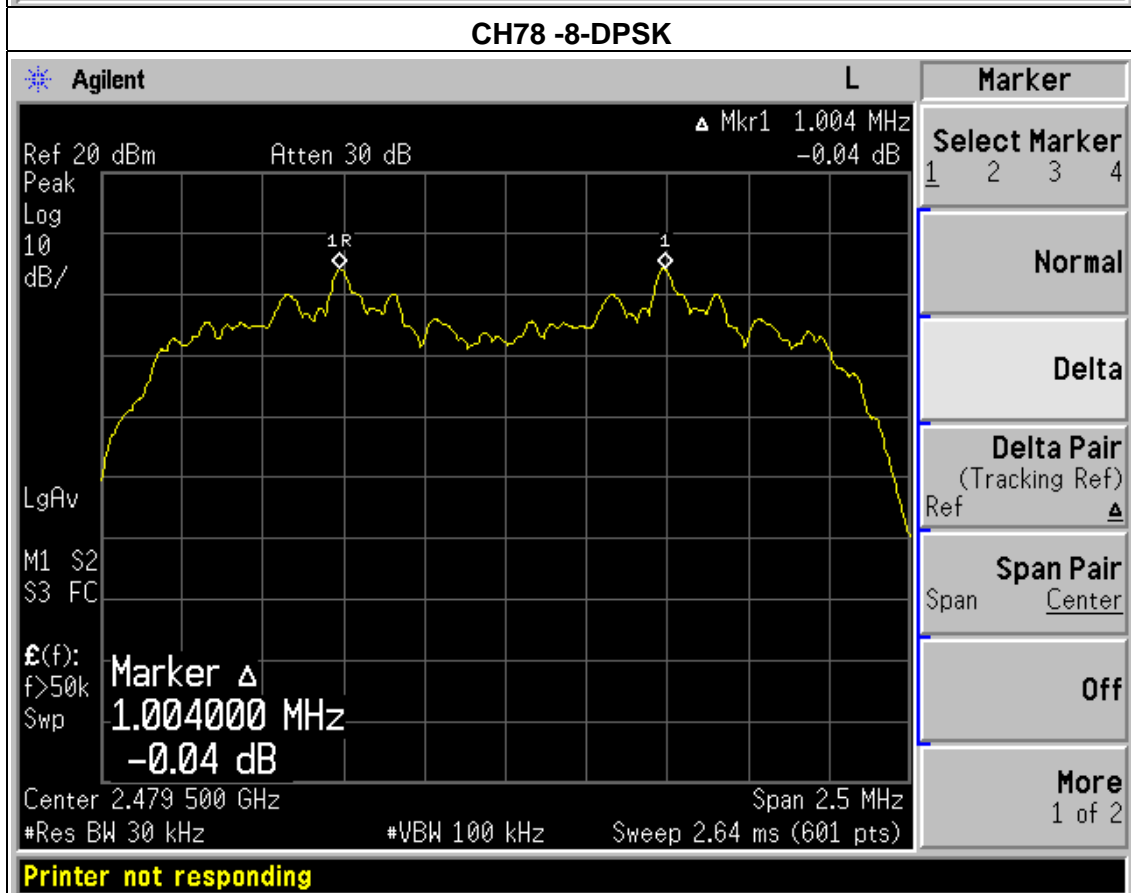
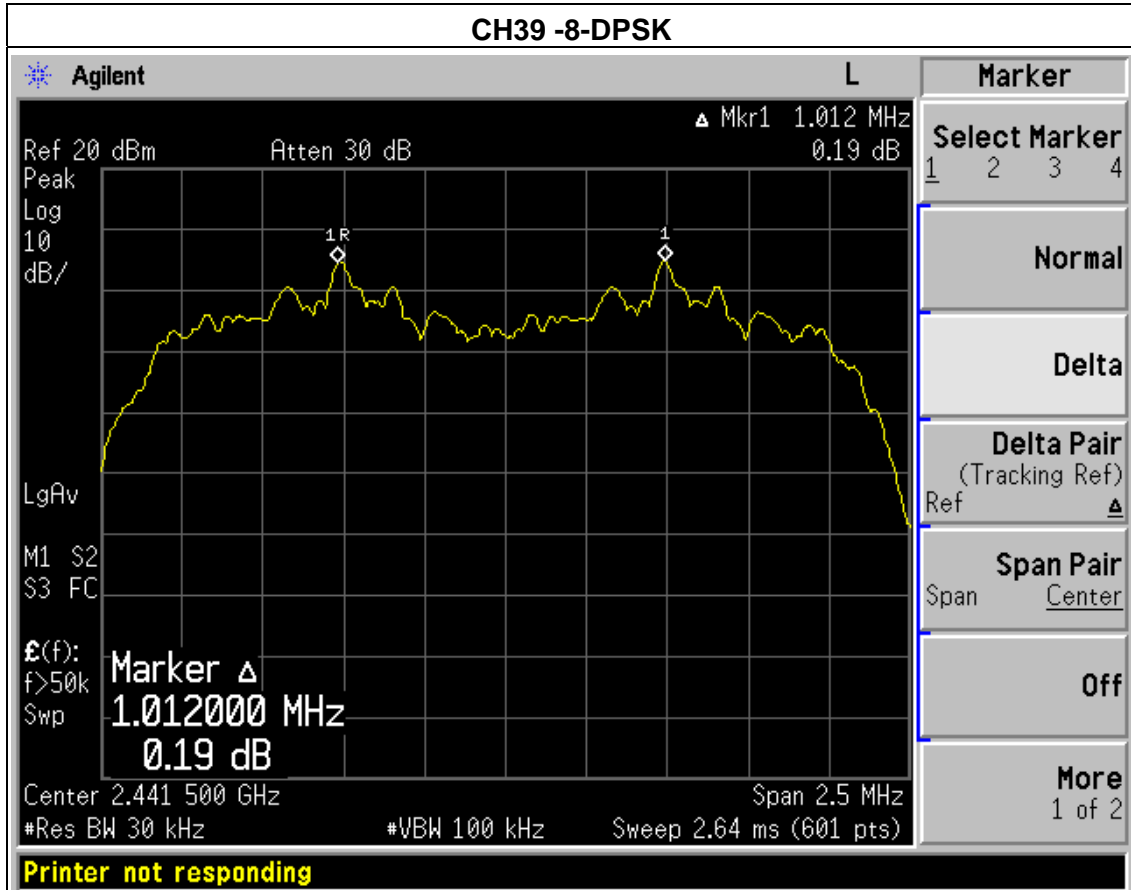

7. BANDWIDTH TEST

7.1 APPLIED PROCEDURES / LIMIT

FCC Part15 (15.247) , Subpart C				
Section	Test Item	Limit	Frequency Range (MHz)	Result
15.247 (a)(1)	Bandwidth	(20dB bandwidth)	2400-2483.5	PASS

Spectrum Parameter	Setting
Attenuation	Auto
Span Frequency	> Measurement Bandwidth or Channel Separation
RB	30 kHz
VB	100 kHz
Detector	Peak
Trace	Max Hold
Sweep Time	Auto

7.1.1 TEST PROCEDURE

- a. The EUT was directly connected to the spectrum analyzer and antenna output port as show in the block diagram below,
- b. Spectrum Setting : RBW= 30KHz, VBW=100KHz, Sweep time = Auto.

7.1.2 DEVIATION FROM STANDARD

No deviation.

7.1.3 TEST SETUP

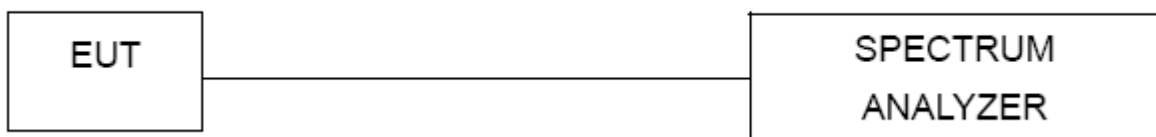

7.1.4 EUT OPERATION CONDITIONS

The EUT tested system was configured as the statements of 2.4 Unless otherwise a special operating condition is specified in the follows during the testing.

7.1.5 TEST RESULTS

EUT :	Sacool Pro	Model Name :	BTHS-AS8P
Temperature :	25 °C	Relative Humidity :	60%
Pressure :	1012 hPa	Test Voltage :	DC 3.7V
Test Mode :	CH00 / CH39 /C78(GFSK)		

Frequency	20dB Bandwidth (kHz)	Result
2402 MHz	909.708	PASS
2441 MHz	881.399	PASS
2480 MHz	856.356	PASS

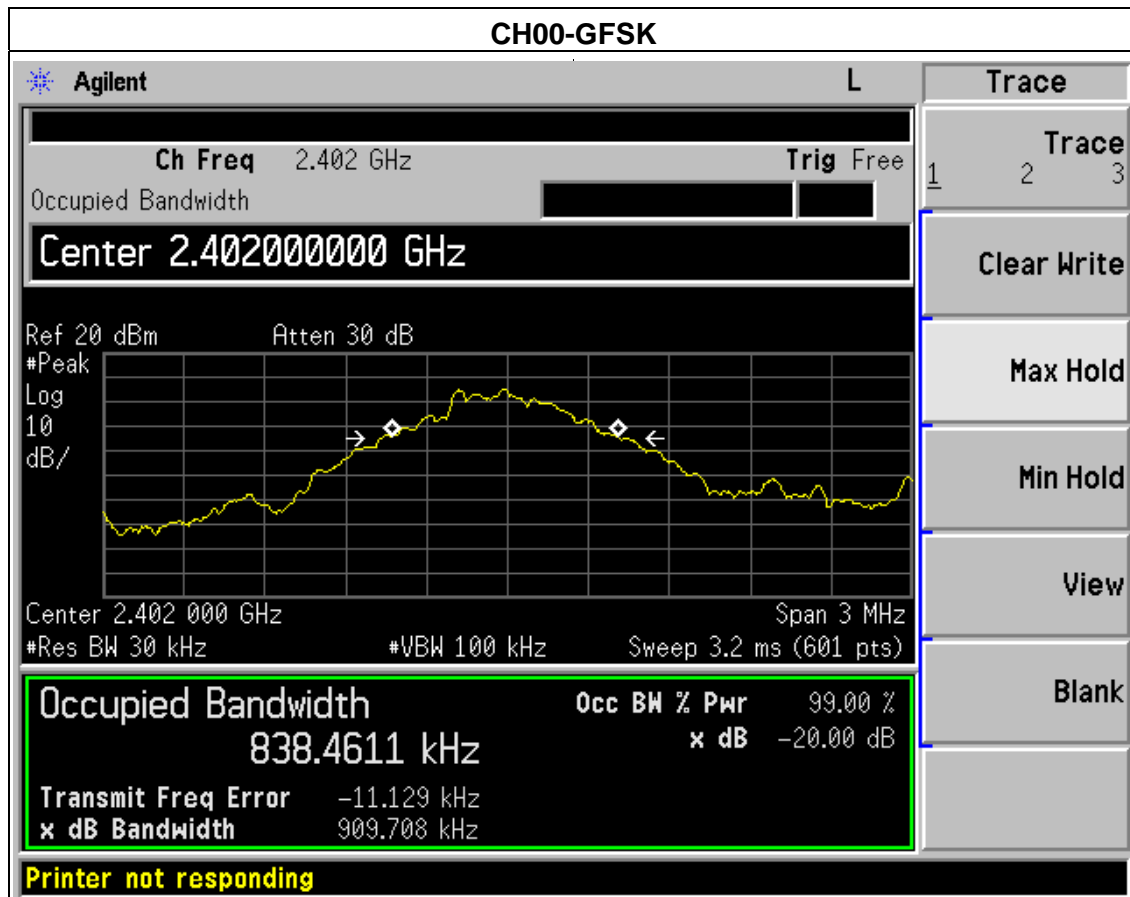

CH39 -GFSK

Agilent
L

Ch Freq 2.441 GHz **Trig** Free

Occupied Bandwidth

Center 2.441000000 GHz

Center Freq
2.44100000 GHz

Start Freq
2.43950000 GHz

Stop Freq
2.44250000 GHz

CF Step
300.000000 kHz
Auto Man

Freq Offset
0.00000000 Hz

Signal Track
On Off

Ref 20 dBm Atten 30 dB

Center 2.441 000 GHz Span 3 MHz
#Res BW 30 kHz #VBW 100 kHz Sweep 3.2 ms (601 pts)

Occupied Bandwidth **Occ BW % Pwr** 99.00 %

826.5694 kHz **x dB** -20.00 dB

Transmit Freq Error -23.558 kHz

x dB Bandwidth 881.399 kHz

Printer not responding

CH78 -GFSK

Agilent
L

Ch Freq 2.48 GHz **Trig** Free

Occupied Bandwidth

Trace

1 2 3

Clear Write

Max Hold

Min Hold

View

Blank

Ref 20 dBm Atten 30 dB

Center 2.480 000 GHz Span 3 MHz
#Res BW 30 kHz #VBW 100 kHz Sweep 3.2 ms (601 pts)

Occupied Bandwidth **Occ BW % Pwr** 99.00 %

825.4982 kHz **x dB** -20.00 dB

Transmit Freq Error -26.272 kHz

x dB Bandwidth 856.356 kHz

Printer not responding

EUT :	Sacool Pro	Model Name :	BTHS-AS8P
Temperature :	25 °C	Relative Humidity :	60%
Pressure :	1012 hPa	Test Voltage :	DC 3.7V
Test Mode :	CH00 / CH39 /C78($\pi/4$ -DQPSK)		

Frequency	20dB Bandwidth (MHz)	Result
2402 MHz	1.209	PASS
2441 MHz	1.223	PASS
2480 MHz	1.224	PASS

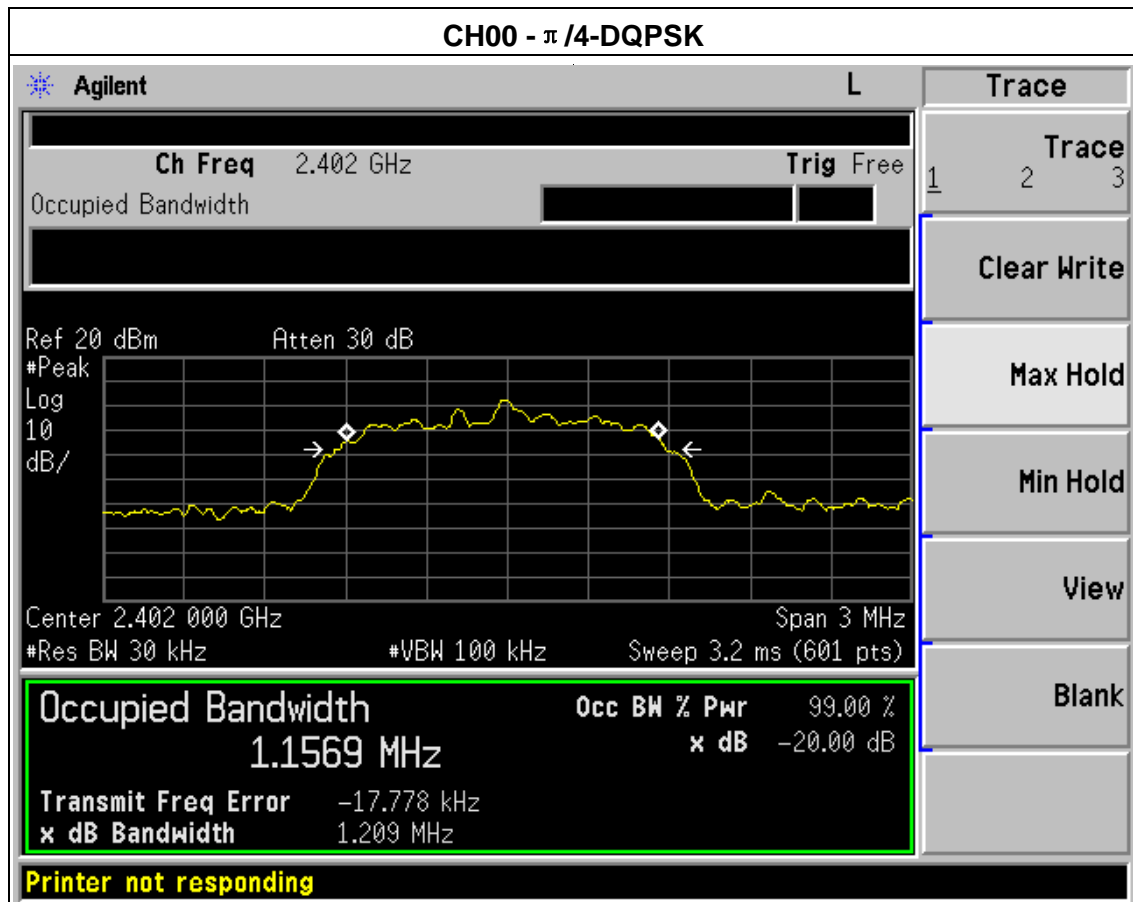

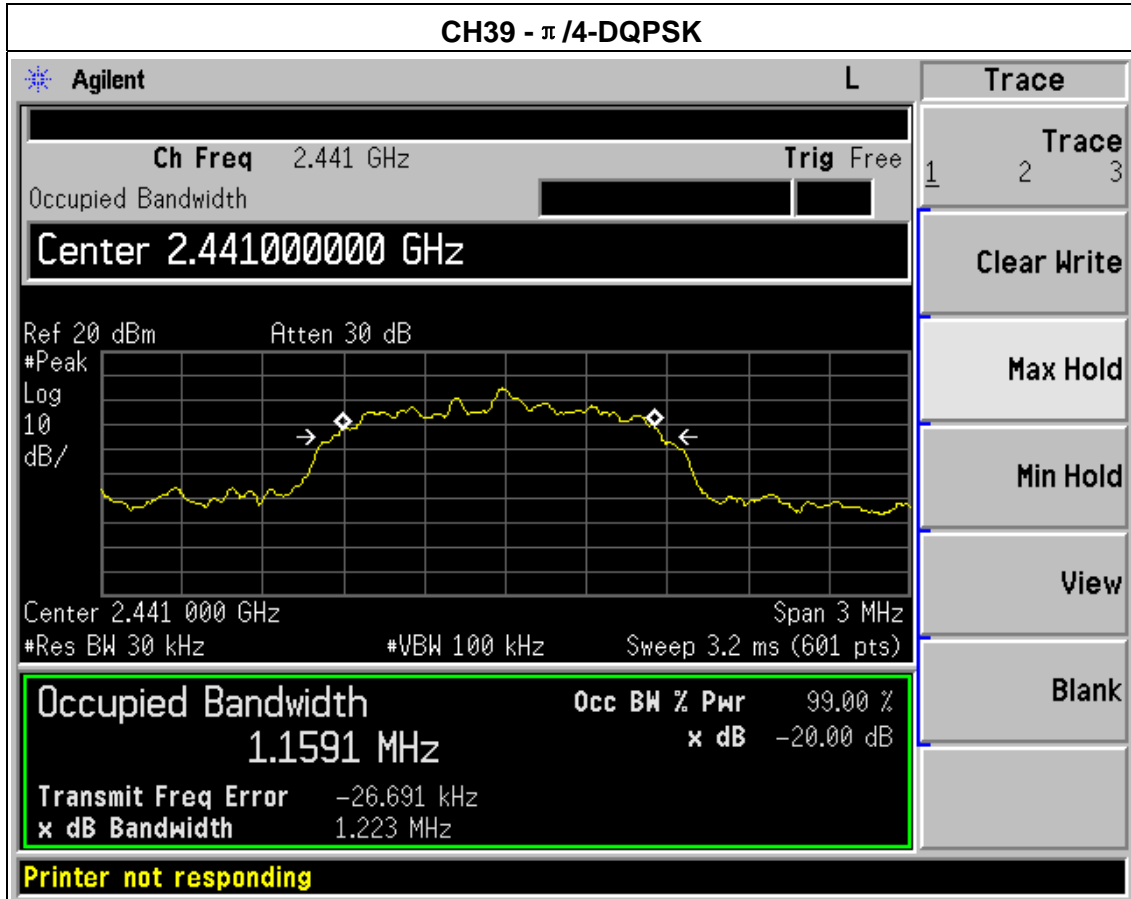

- Trace
- Trace 1 2 3
- Clear Write
- Max Hold
- Min Hold
- View
- Blank

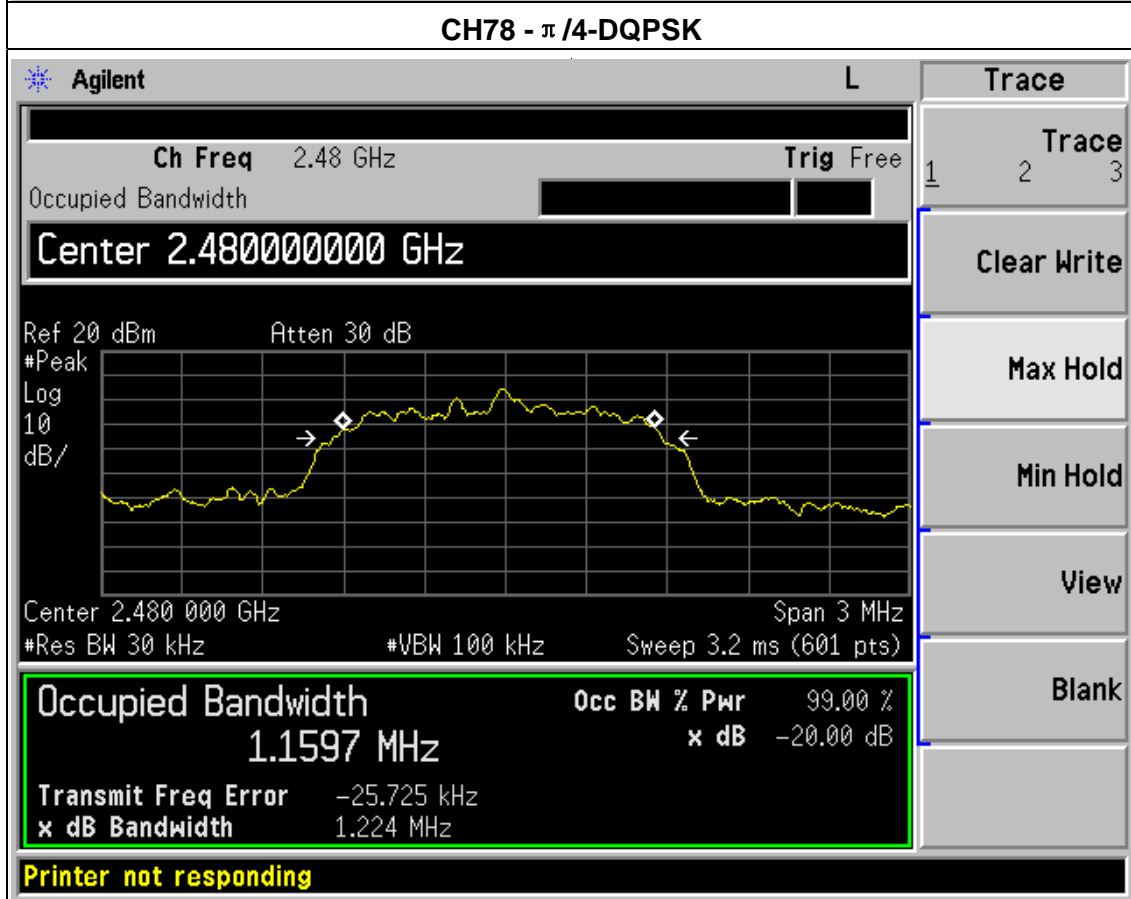

- Trace
- Trace 1 2 3
- Clear Write
- Max Hold
- Min Hold
- View
- Blank

EUT :	Sacool Pro	Model Name :	BTHS-AS8P
Temperature :	25 °C	Relative Humidity :	60%
Pressure :	1012 hPa	Test Voltage :	DC 3.7V
Test Mode :	CH00 / CH39 /C78(8-DPSK)		

Frequency	20dB Bandwidth (MHz)	Result
2402 MHz	1.212	PASS
2441 MHz	1.215	PASS
2480 MHz	1.215	PASS

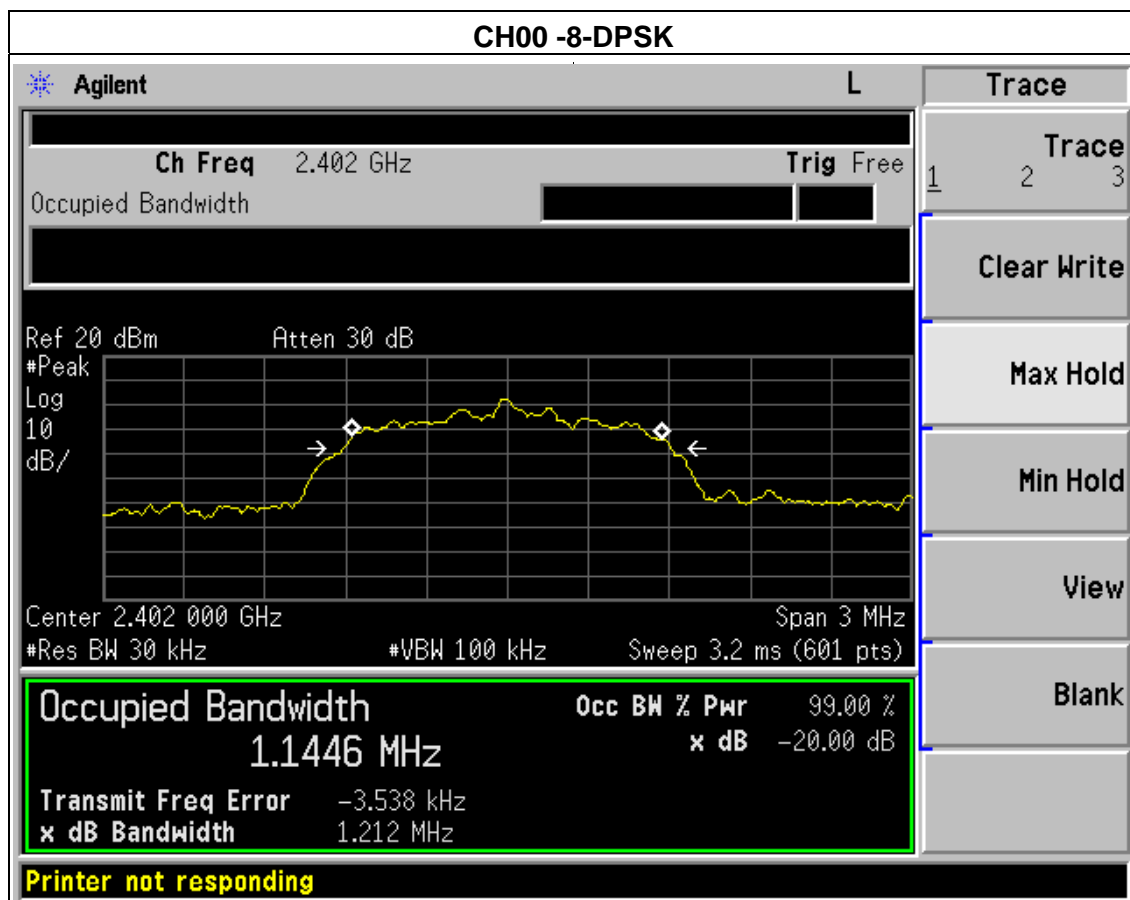

CH39 -8-DPSK

Agilent L

Ch Freq 2.441 GHz Trig Free

Occupied Bandwidth

Center 2.441000000 GHz

Ref 20 dBm Atten 30 dB

#Peak Log 10 dB/

Center 2.441 000 GHz Span 3 MHz
#Res BW 30 kHz #VBW 100 kHz Sweep 3.2 ms (601 pts)

Occupied Bandwidth	Occ BW % Pwr	99.00 %
1.1415 MHz	x dB	-20.00 dB
Transmit Freq Error		-13.427 kHz
x dB Bandwidth		1.215 MHz

Printer not responding

Trace 1 2 3

Clear Write

Max Hold

Min Hold

View

Blank

CH78 -8-DPSK

Agilent L

Ch Freq 2.48 GHz Trig Free

Occupied Bandwidth

VBW 100.0 kHz

Ref 20 dBm Atten 30 dB

#Peak Log 10 dB/

Center 2.480 000 GHz Span 3 MHz
#Res BW 30 kHz #VBW 100 kHz Sweep 3.2 ms (601 pts)

Occupied Bandwidth	Occ BW % Pwr	99.00 %
1.1426 MHz	x dB	-20.00 dB
Transmit Freq Error		-12.482 kHz
x dB Bandwidth		1.215 MHz

Printer not responding

Trace 1 2 3

Clear Write

Max Hold

Min Hold

View

Blank

8. PEAK OUTPUT POWER TEST

8.1 APPLIED PROCEDURES / LIMIT

FCC Part15 (15.247) , Subpart C				
Section	Test Item	Limit	Frequency Range (MHz)	Result
15.247 (b)(i)	Peak Output Power	0.125 w or 20.96dBm	2400-2483.5	PASS

8.1.1 TEST PROCEDURE

- a. The EUT was directly connected to the spectrum analyzer and antenna output port as show in the block diagram below,
- b. Spectrum Setting : RBW > the 20 dB bandwidth of the emission being measured
 - Span = approximately 5 times the 20 dB bandwidth, centered on a hopping channel
 - VBW ≥ RBW
 - Sweep = auto
 - Detector function = peak
 - Trace = max hold

8.1.2 DEVIATION FROM STANDARD

No deviation.

8.1.3 TEST SETUP



8.1.4 EUT OPERATION CONDITIONS

The EUT tested system was configured as the statements of 2.4 Unless otherwise a special operating condition is specified in the follows during the testing.

8.1.5 TEST RESULTS

EUT :	Sacool Pro	Model Name :	BTHS-AS8P
Temperature :	25 °C	Relative Humidity :	60%
Pressure :	1012 hPa	Test Voltage :	DC 3.7V
Test Mode :	CH00/ CH39 /CH78 (1M/2M/8-DPSK Mode)		

GFSK			
Test Channel	Frequency (MHz)	Peak Output Power (dBm)	LIMIT (dBm)
CH00	2402	6.47	30
CH39	2441	7.57	30
CH78	2480	7.18	30
π /4-DQPSK			
CH00	2402	5.42	20.96
CH39	2441	6.24	20.96
CH78	2480	5.73	20.96
8-DPSK			
CH00	2402	5.67	20.96
CH39	2441	6.64	20.96
CH78	2480	6.14	20.96

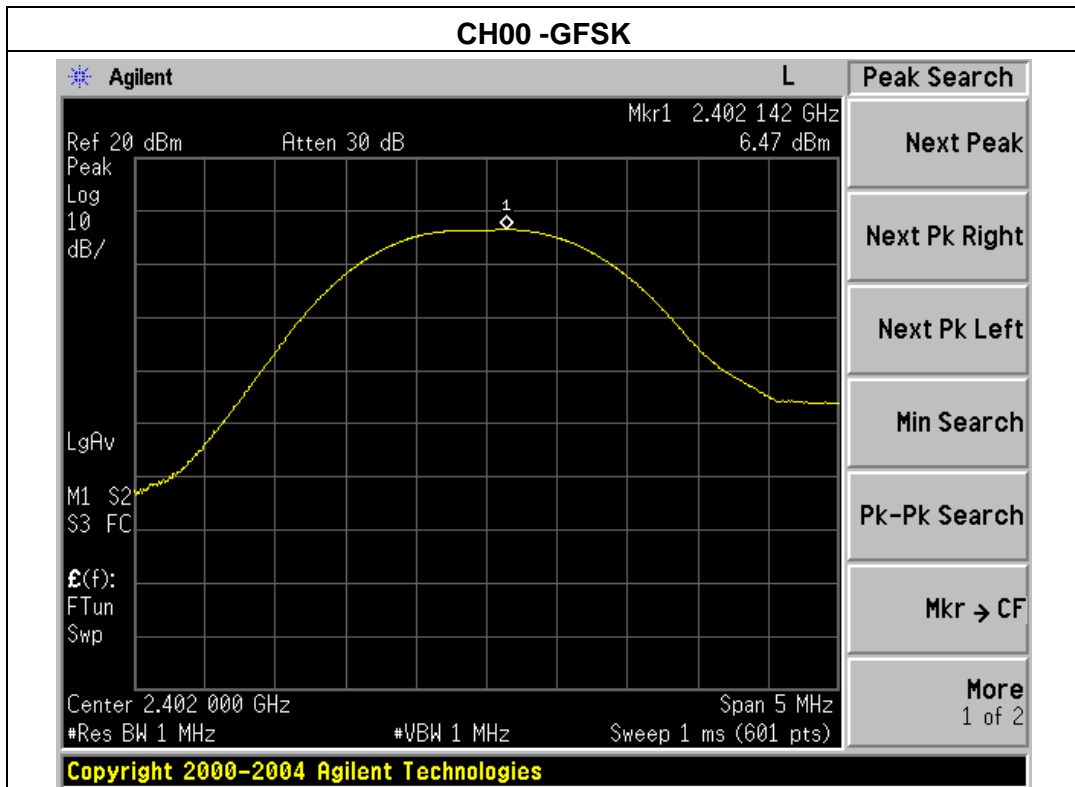

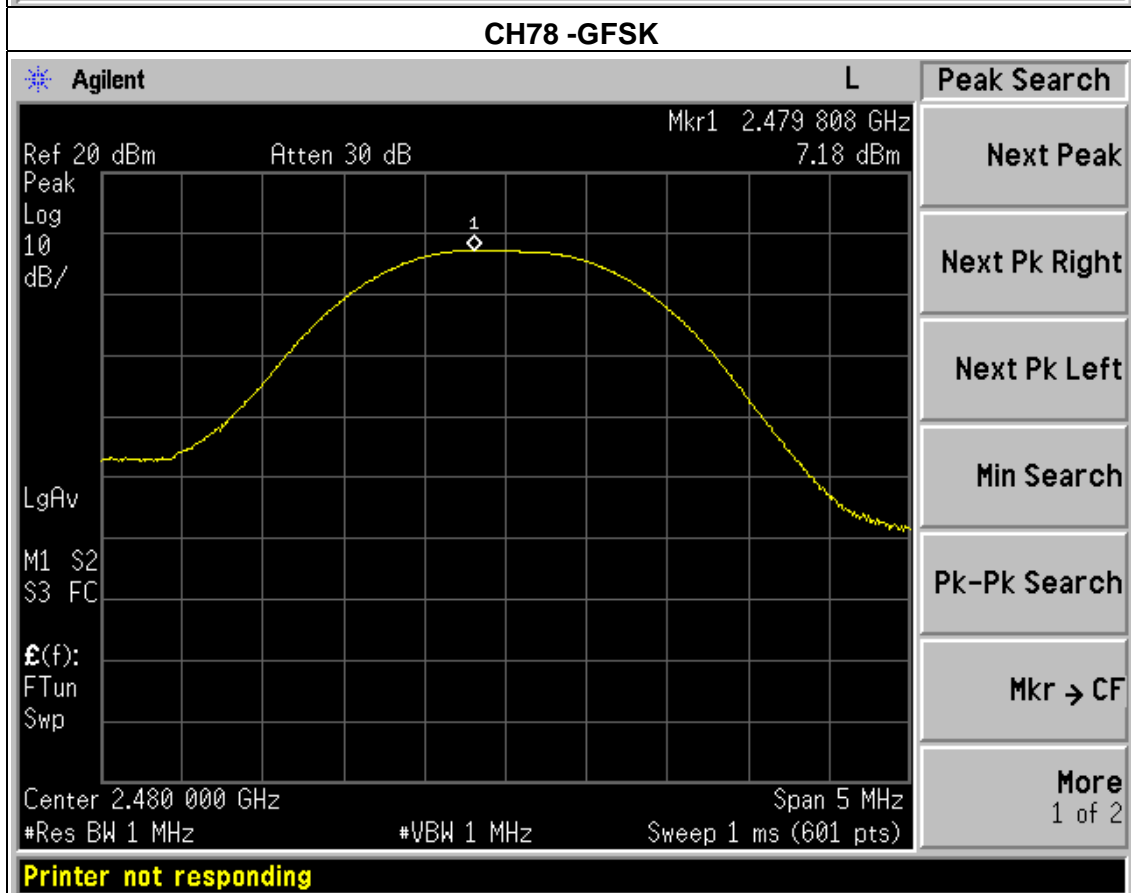
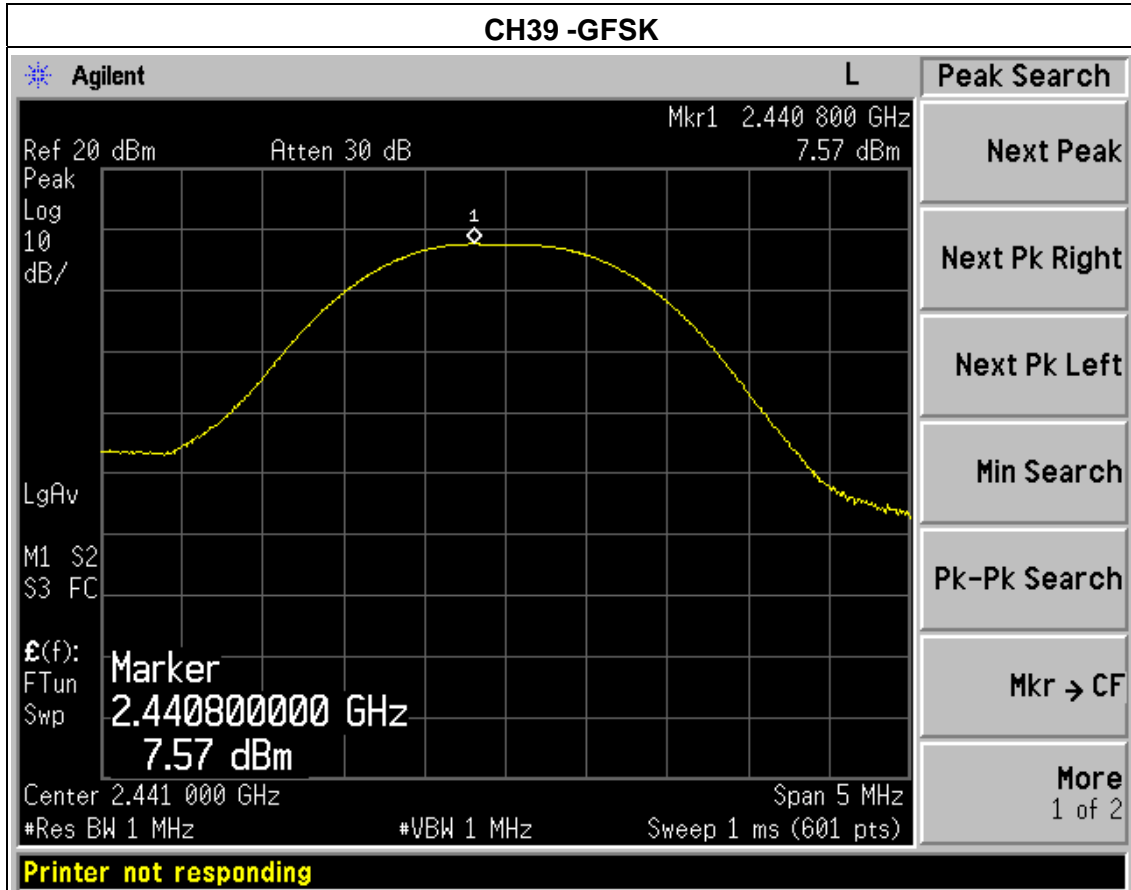

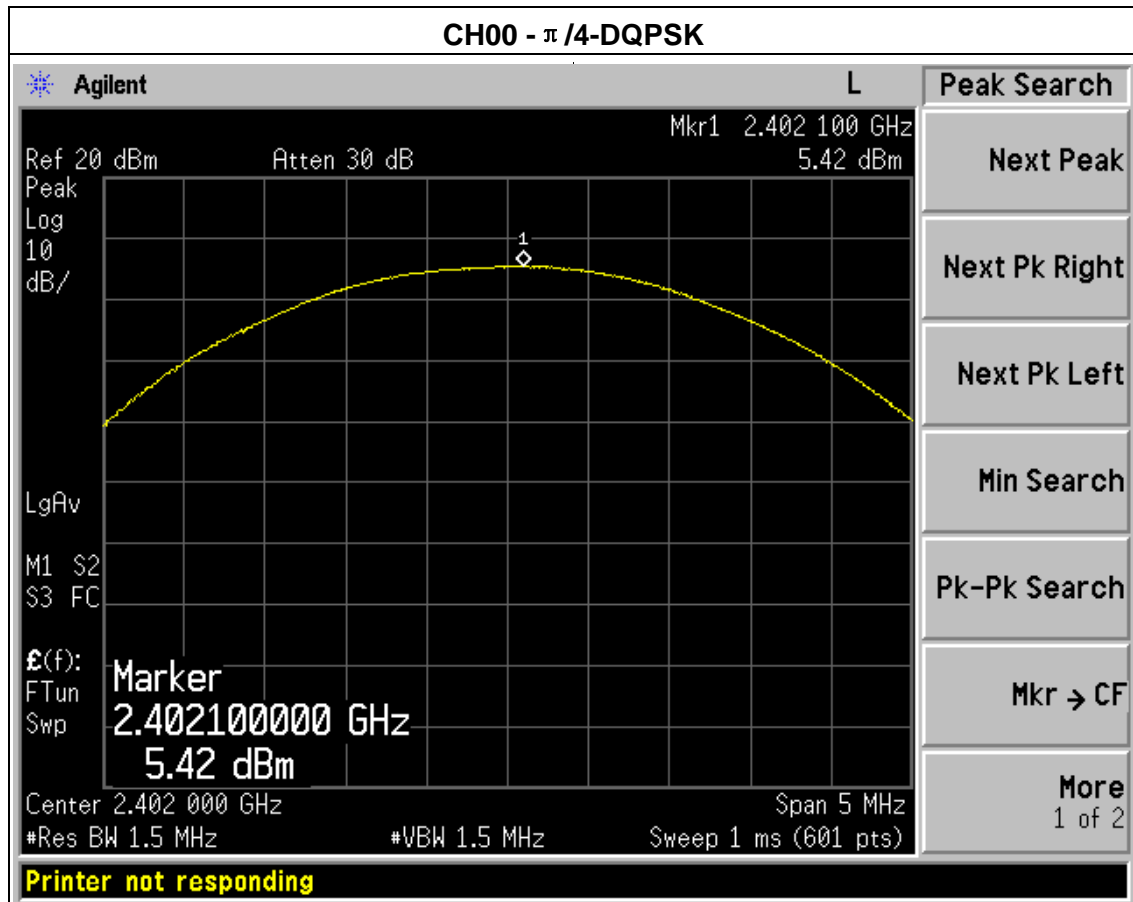

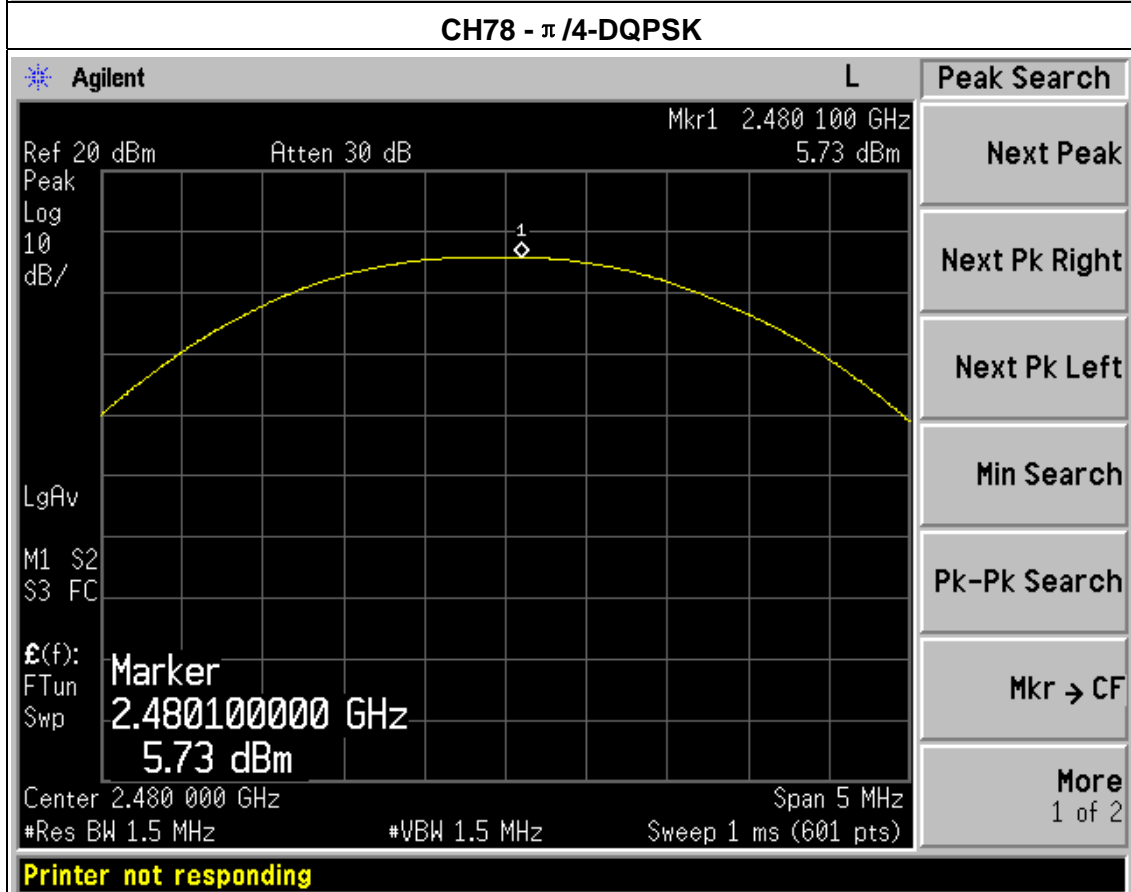
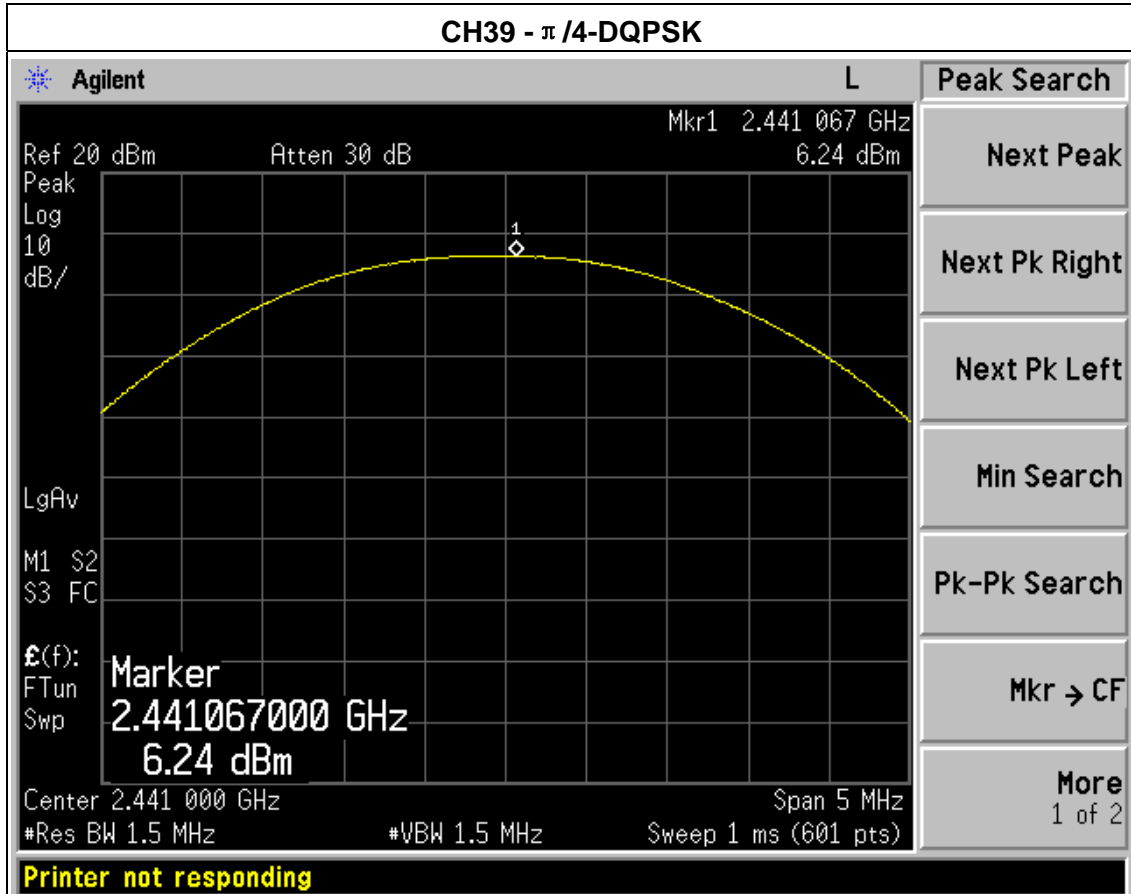

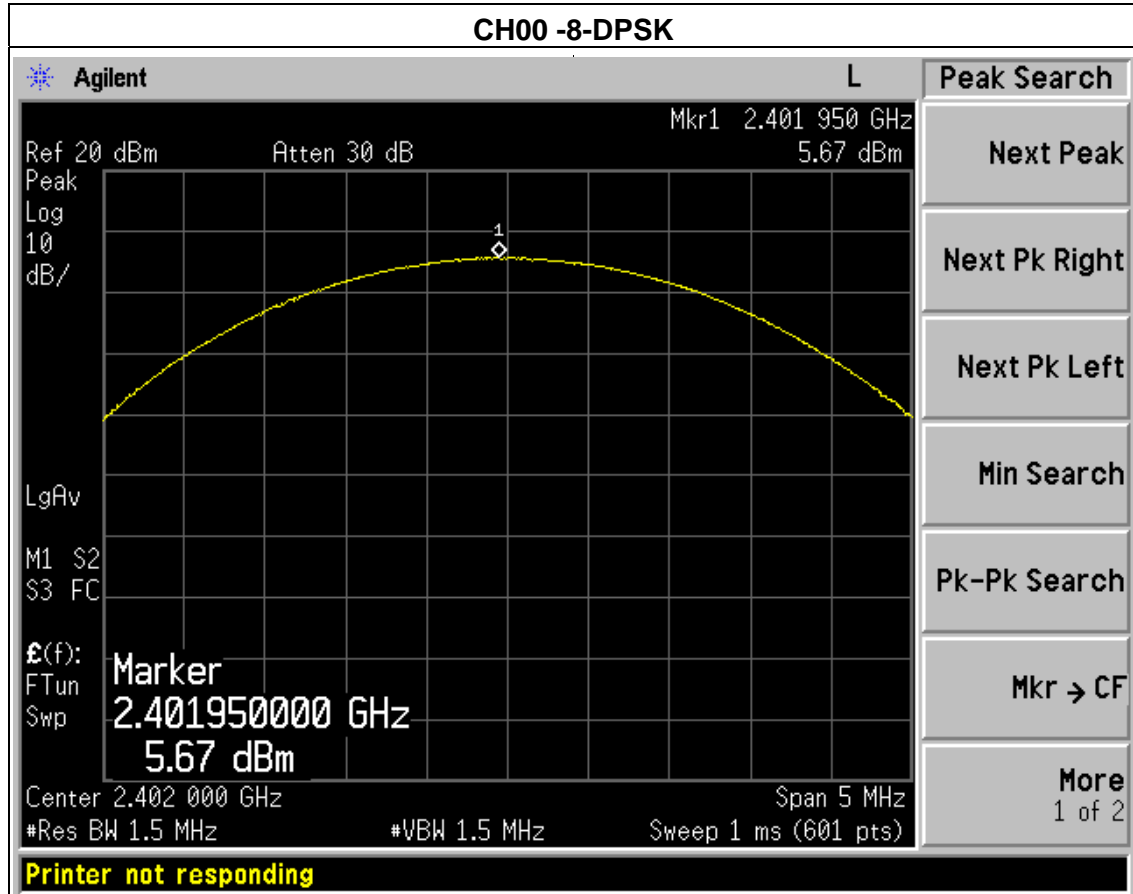

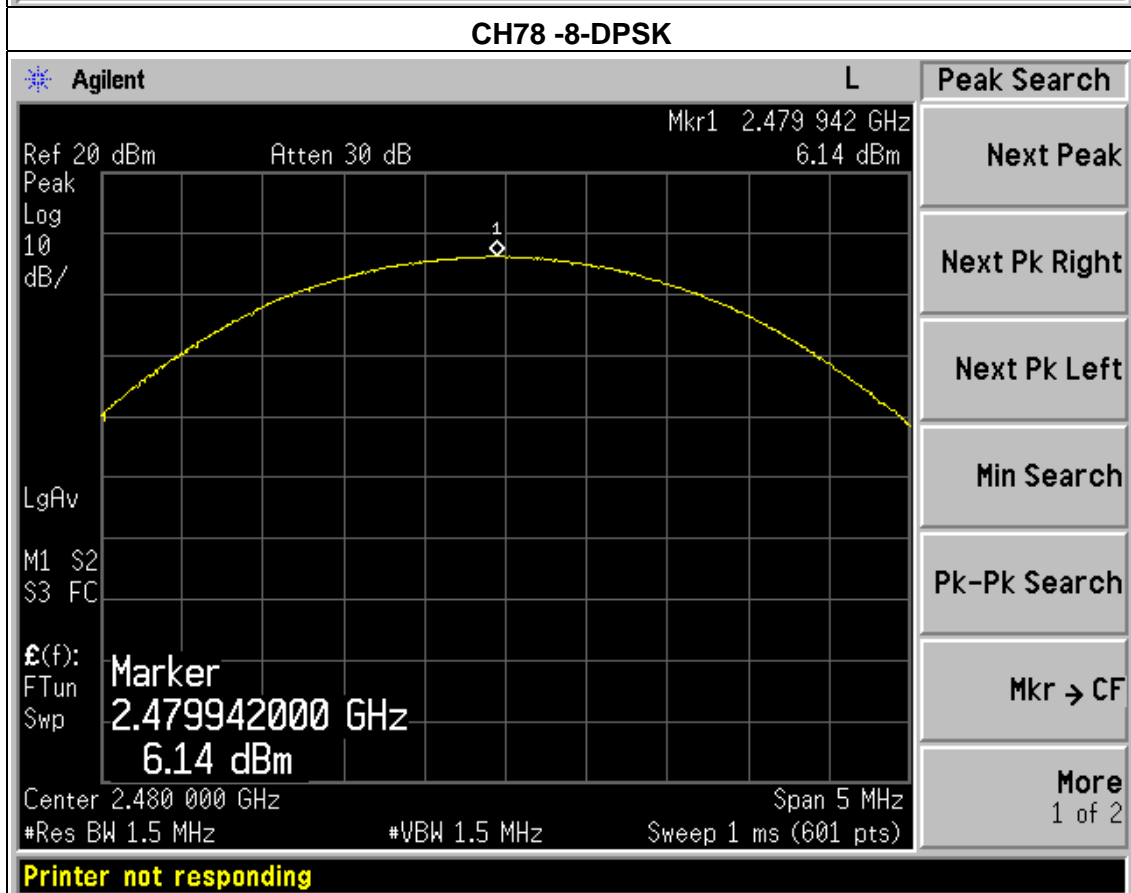
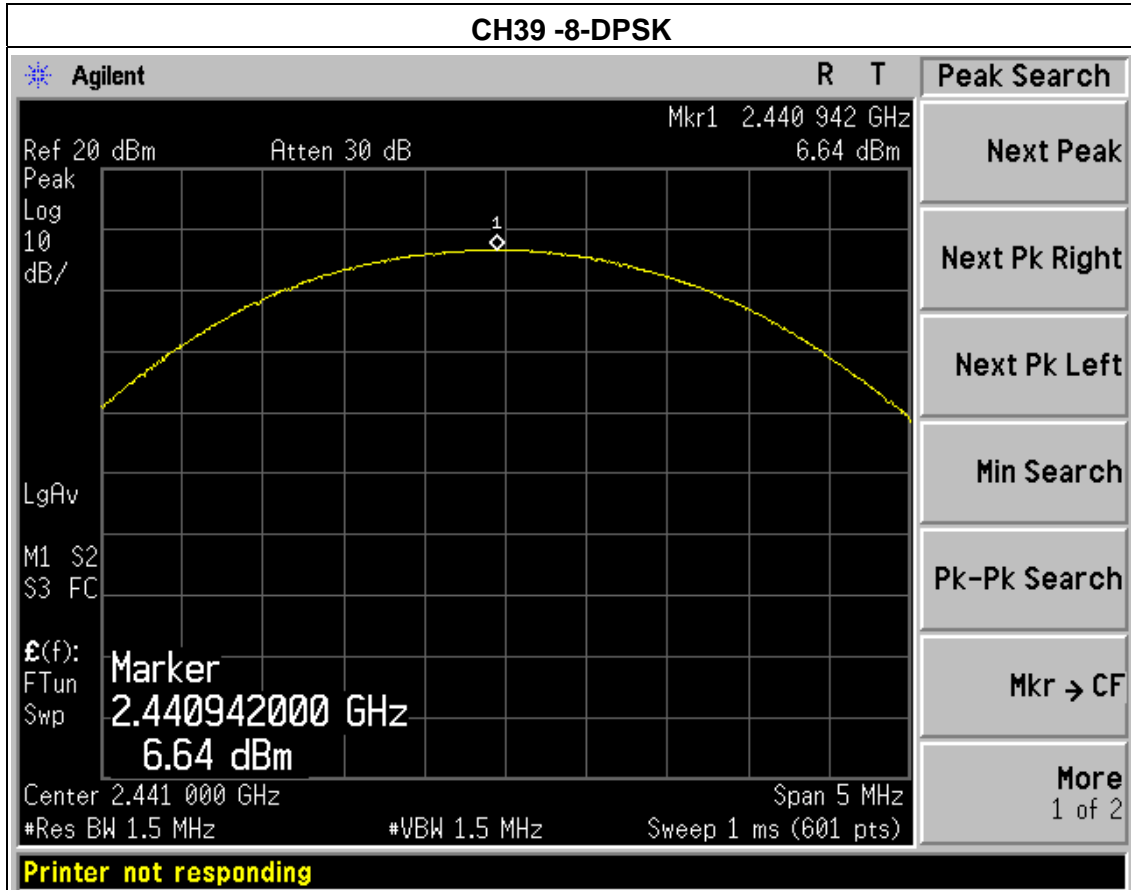

9. 100 KHZ BANDWIDTH OF FREQUENCY BAND EDGE

APPLICABLE STANDARD

In any 100 kHz bandwidth outside the frequency band in which the spread spectrum or digitally modulated intentional radiator is operating, the radio frequency power that is produced by the intentional radiator shall be at least 20 dB below that in the 100 kHz bandwidth within the band that contains the highest level of the desired power, based on either an RF conducted or a radiated measurement, provided the transmitter demonstrates compliance with the peak conducted power limits. If the transmitter complies with the conducted power limits based on the use of RMS averaging over a time interval, as permitted under paragraph (b)(3) of this section, the attenuation required under this paragraph shall be 30 dB instead of 20 dB. Attenuation below the general limits specified in §15.209(a) is not required. In addition, radiated emissions which fall in the restricted bands, as defined in §15.205(a), must also comply with the radiated emission limits specified in §15.209(a) (see §15.205(c)).

TEST PROCEDURE

- a) Check the calibration of the measuring instrument using either an internal calibrator or a known signal from an external generator.
- b) Position the EUT without connection to measurement instrument. Turn on the EUT and connect its antenna terminal to measurement instrument via a low loss cable. Then set it to any one measured frequency within its operating range, and make sure the instrument is operated in its linear range.
- c) Set RBW to 100 kHz and VBW of spectrum analyzer to 300 kHz with a convenient frequency span including 100 kHz bandwidth from band edge.
- d) Measure the highest amplitude appearing on spectral display and set it as a reference level. Plot the graph with marking the highest point and edge frequency.
- e) Repeat above procedures until all measured frequencies were complete.

9.1 DEVIATION FROM STANDARD

No deviation.

9.2 TEST SETUP



9.3 EUT OPERATION CONDITIONS

The EUT tested system was configured as the statements of 2.4 Unless otherwise a special operating condition is specified in the follows during the testing.

9.4 TEST RESULTS

EUT :	Sacool Pro	Model Name :	BTHS-AS8P
Temperature :	25 °C	Relative Humidity :	60%
Pressure :	1012 hPa	Test Voltage :	DC 3.7V
Test Mode :	CH00/ CH78		

Frequency Band	Delta Peak to band emission (dBc)	> Limit (dBc)	Result
GFSK Non-hopping			
2400	54.68	20	Pass
2483.5	66.22	20	Pass
$\pi/4$ -DQPSK Non-hopping			
2400	50.72	20	Pass
2483.5	61.55	20	Pass
8-DPSK Non-hopping			
2400	50.57	20	Pass
2483.5	60.83	20	Pass
GFSK hopping			
2400	52.97	20	Pass
2483.5	67.58	20	Pass
$\pi/4$ -DQPSK hopping			
2400	53.36	20	Pass
2483.5	53.44	20	Pass
8-DPSK hopping			
2400	54.41	20	Pass
2483.5	54.91	20	Pass

BDR mode (GFSK): Band Edge-Left Side

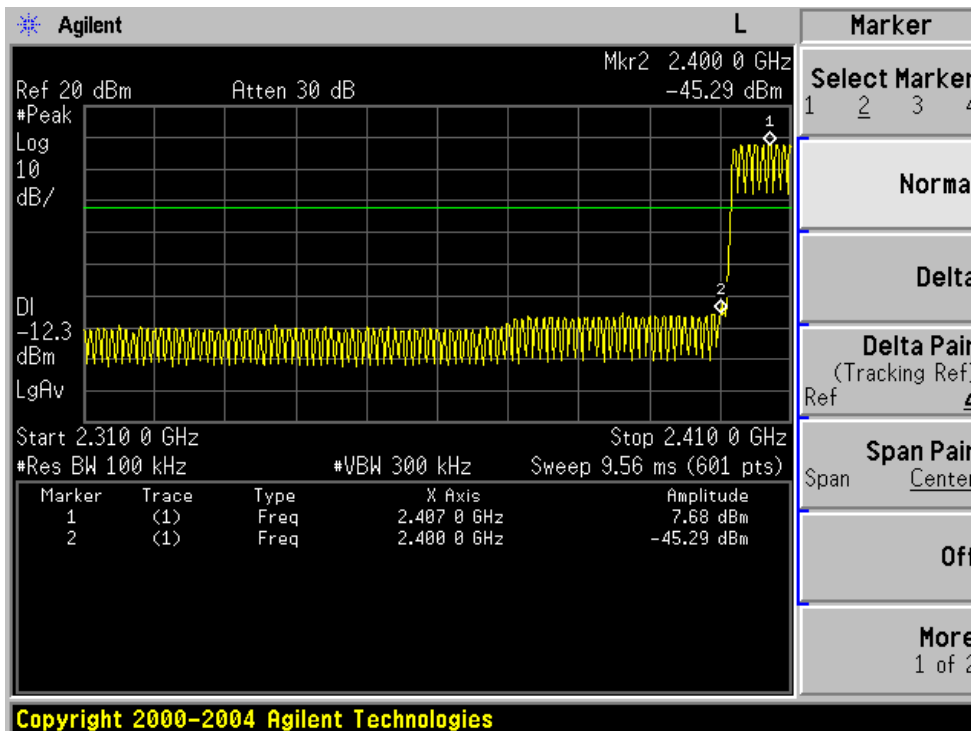
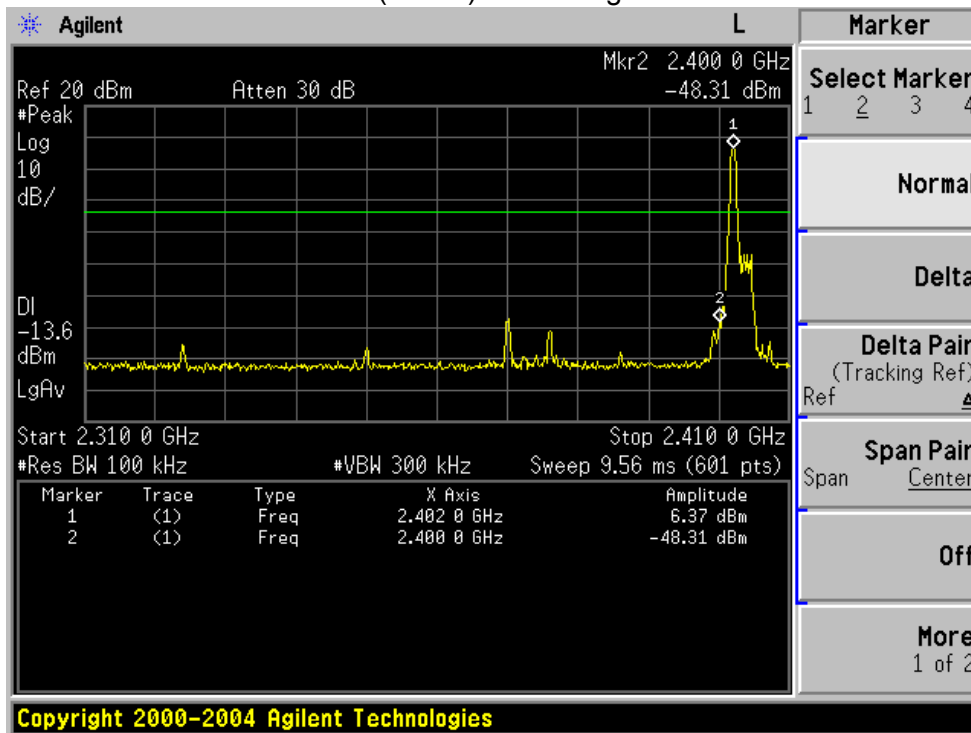

BDR mode (GFSK): Band Edge-Right Side

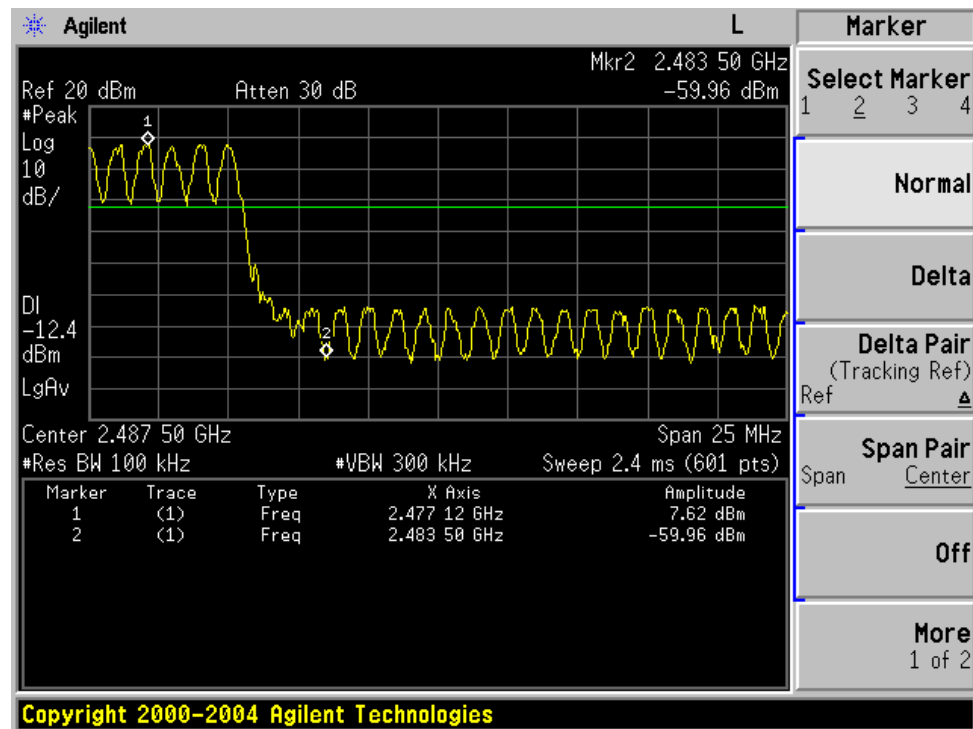
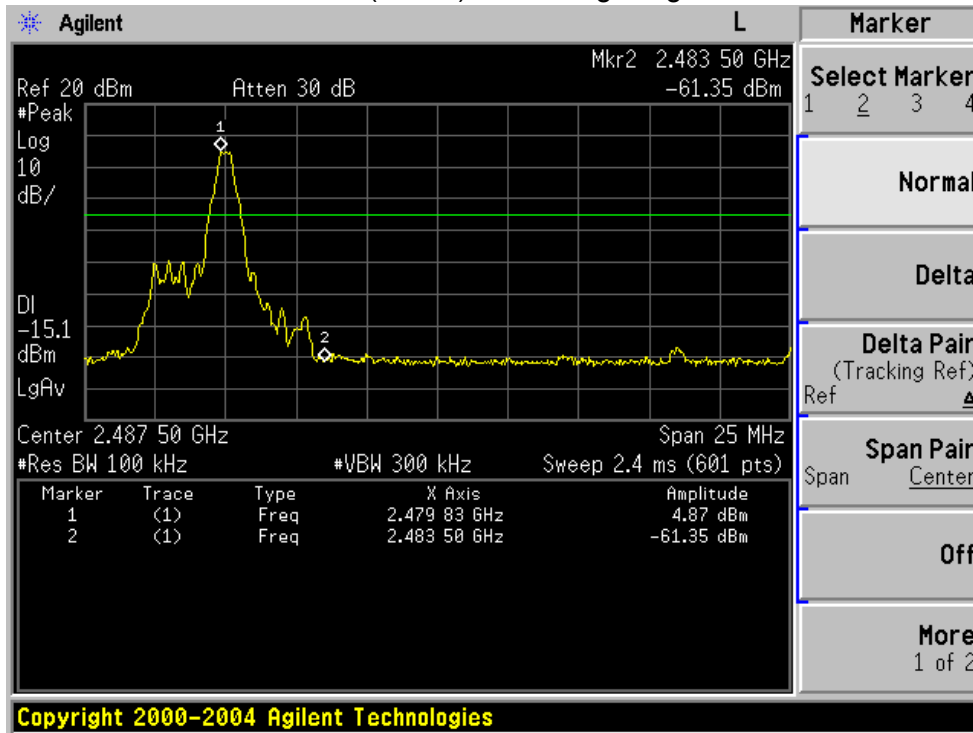

EDR mode ($\pi/4$ -DQPSK): Band Edge-Left Side

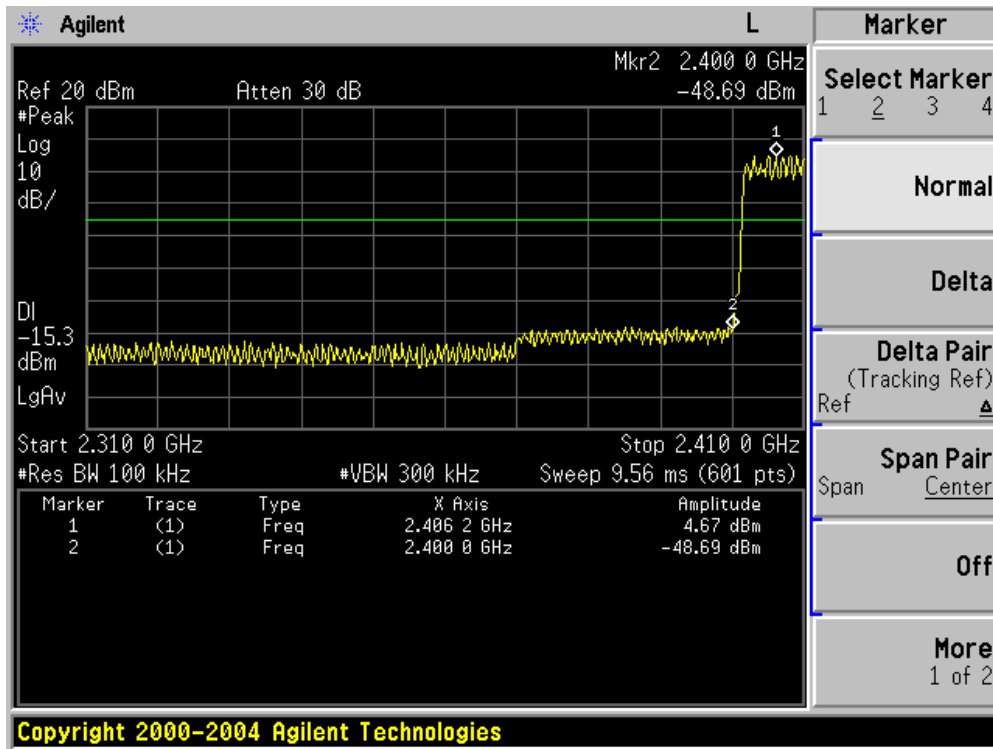
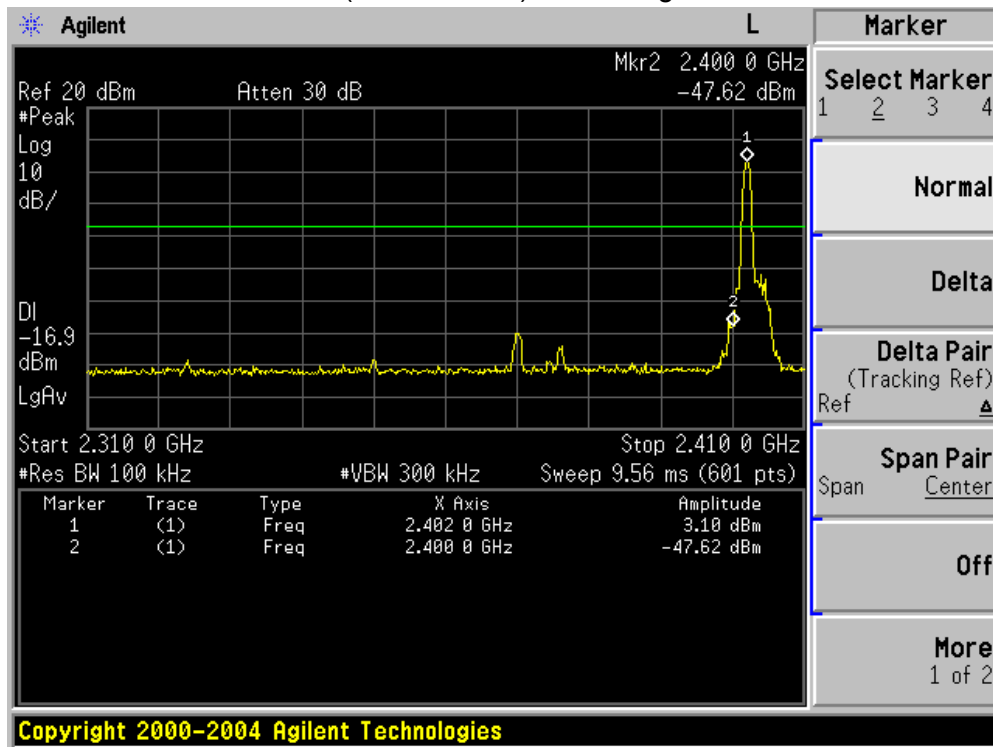

EDR mode ($\pi/4$ -DQPSK): Band Edge- Right Side

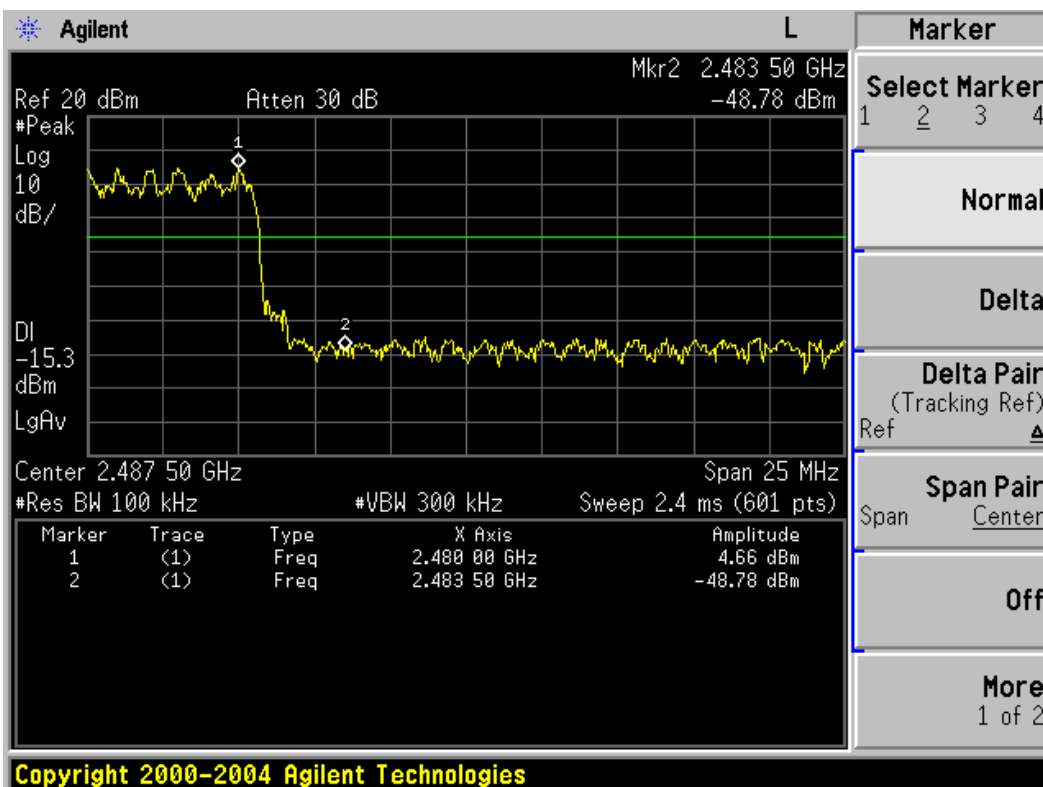
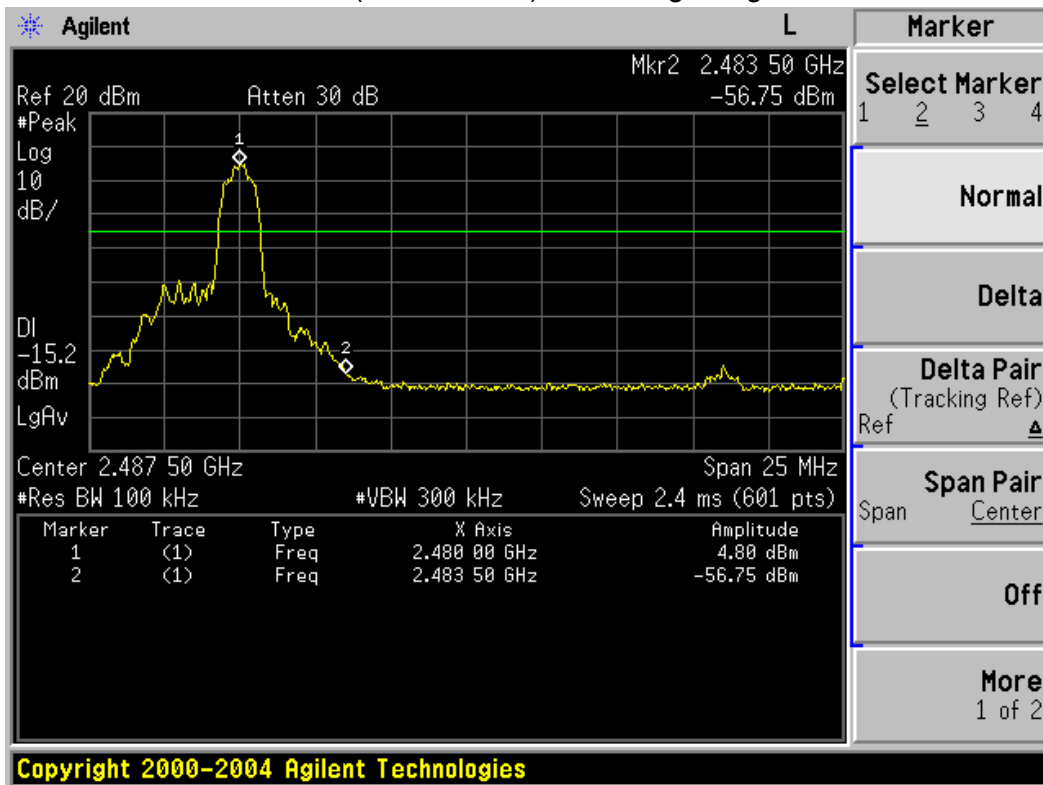

EDR mode(8-DPSK): Band Edge-Left Side

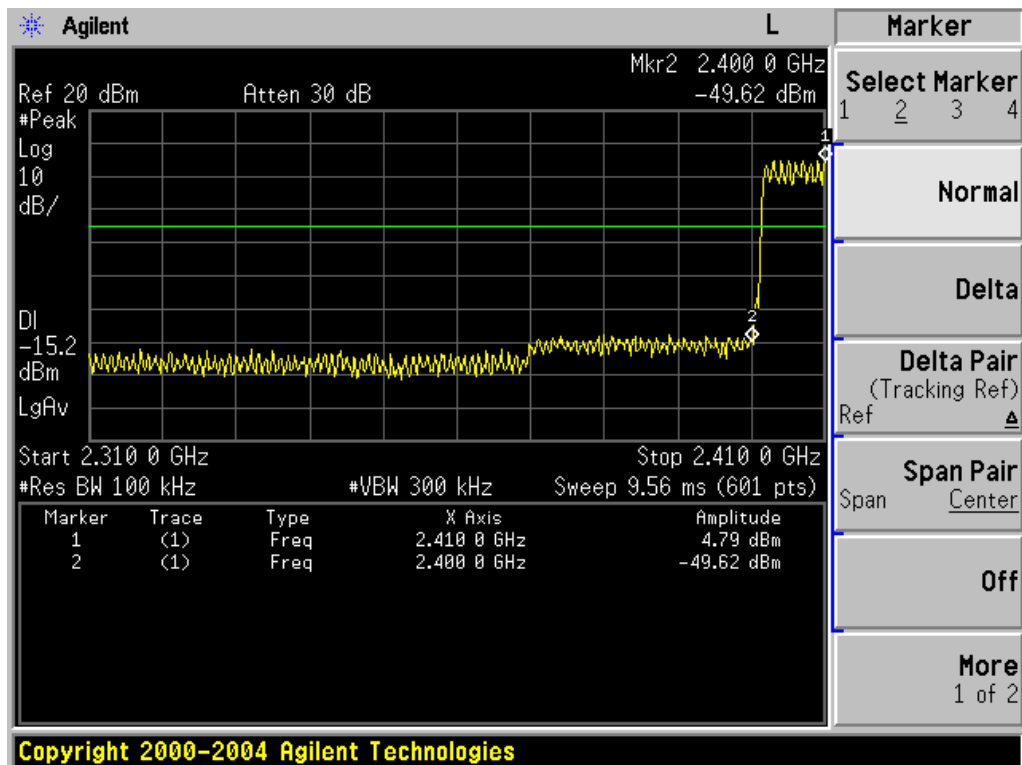
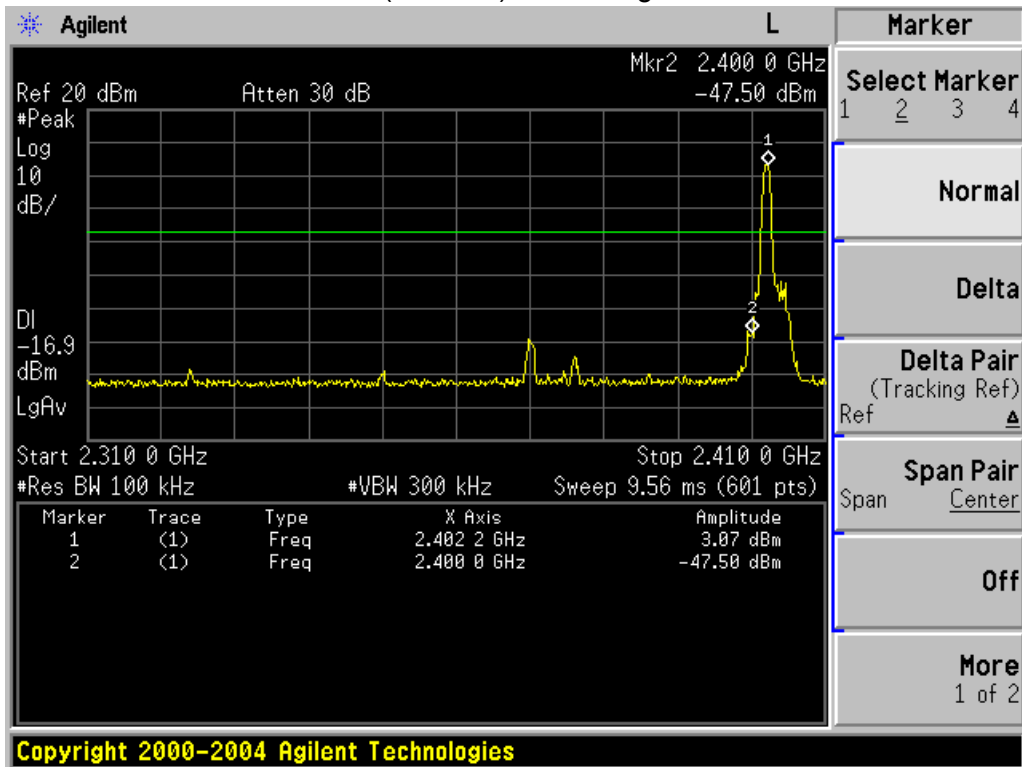

EDR mode(8-DPSK): Band Edge-Right Side

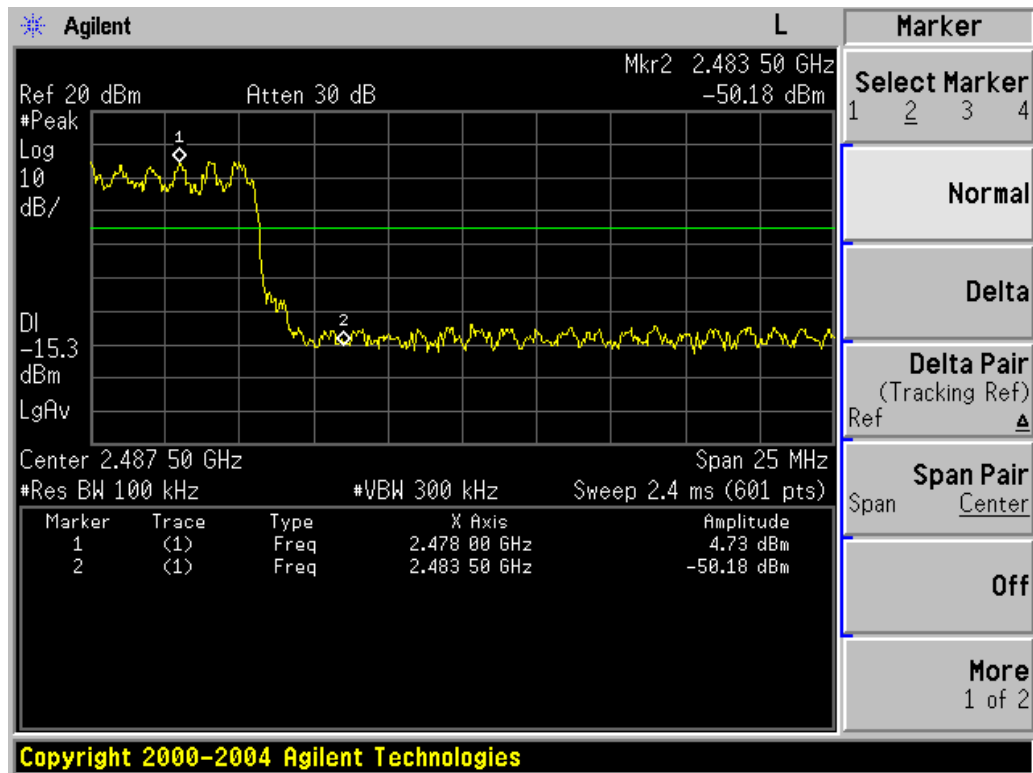
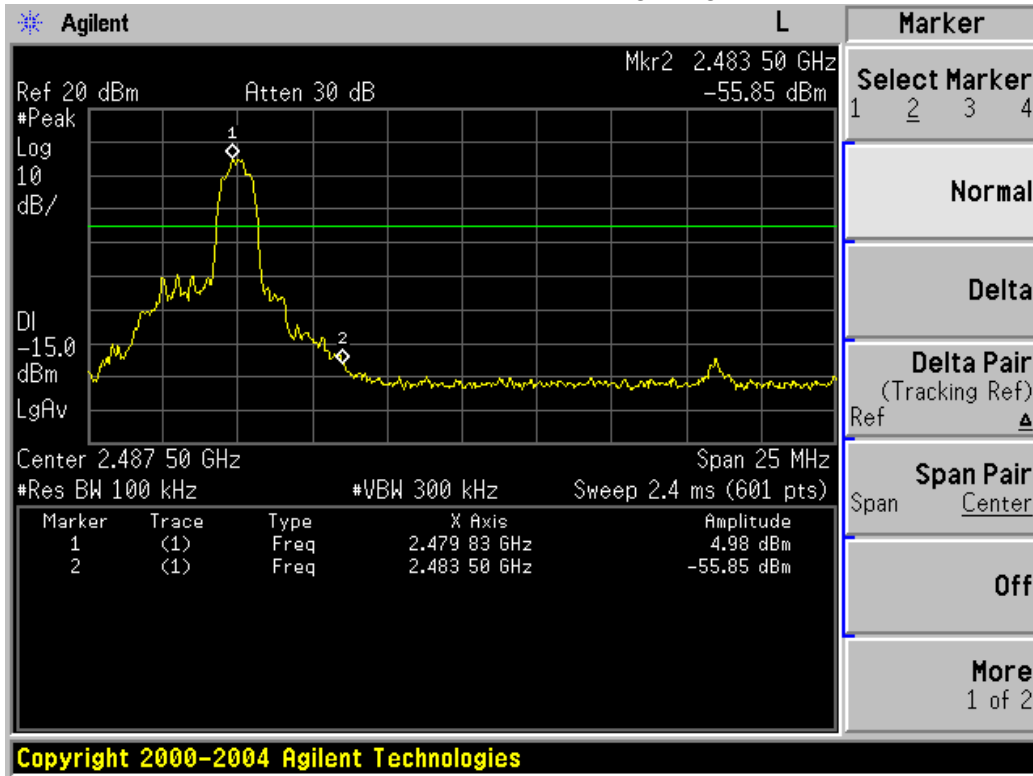

NOTE: Hopping enabled and disabled have evaluated, and the worst data was reported

10. ANTENNA REQUIREMENT

10.1 STANDARD REQUIREMENT

15.203 requirement: For intentional device, according to 15.203: an intentional radiator shall be designed to ensure that no antenna other than that furnished by the responsible party shall be used with the device.

10.2 EUT ANTENNA

The EUT antenna is permanent attached antenna. It comply with the standard requirement.

11. EUT TEST PHOTO

Radiated Measurement Photos

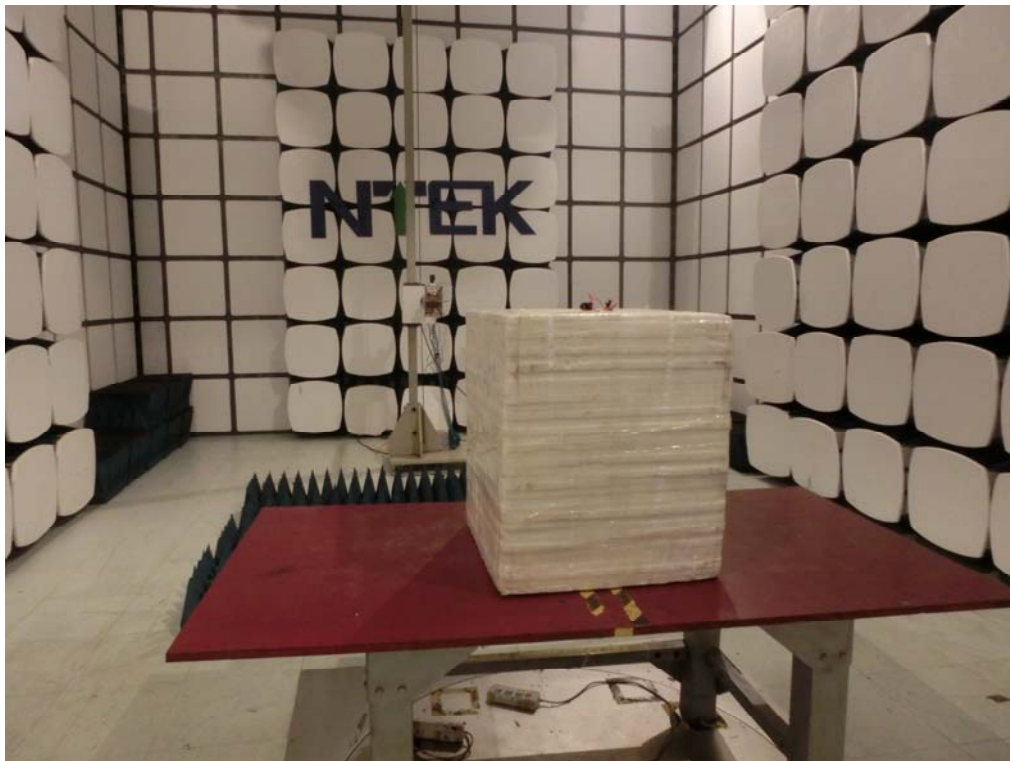

CONDUCTED EMISSION Photos

