

CDMA_BC1 Band

Frequency: 1880 MHz; Duty Cycle: 1:1; Room Ambient Temperature: 24.0°C; Liquid Temperature: 23.0°C

Medium parameters used (interpolated): $f = 1880$ MHz; $\sigma = 1.54$ mho/m; $\epsilon_r = 54.1$; $\rho = 1000$ kg/m³ ;

DASY4 Configuration:

- Area Scan setting - Find Secondary Maximum Within: 2.0 dB and with a peak SAR value greater than 0.0012W/kg
- Electronics: DAE4 Sn558; Calibrated: 7/22/2014
- Probe: EX3DV4 - SN3554; ConvF(6.54, 6.54, 6.54); Calibrated: 9/24/2014
- Sensor-Surface: 2mm (Mechanical Surface Detection)
- Phantom: SAM 34-2; Type: SAM V4.0; Serial: TP-1150

Bottom/Main Ant/CDMA_BC1/Ch 600_5mm/Area Scan (8x7x1): Measurement grid: dx=15mm, dy=15mm

[Info: Interpolated medium parameters used for SAR evaluation.](#)

Maximum value of SAR (measured) = 0.788 mW/g

Bottom/Main Ant/CDMA_BC1/Ch 600_5mm/Zoom Scan (5x5x7)/Cube 0: Measurement grid: dx=8mm, dy=8mm, dz=5mm

Reference Value = 7.26 V/m; Power Drift = -0.114 dB

Peak SAR (extrapolated) = 1.16 W/kg

SAR(1 g) = 0.692 mW/g; SAR(10 g) = 0.392 mW/g

[Info: Interpolated medium parameters used for SAR evaluation.](#)

Maximum value of SAR (measured) = 0.928 mW/g

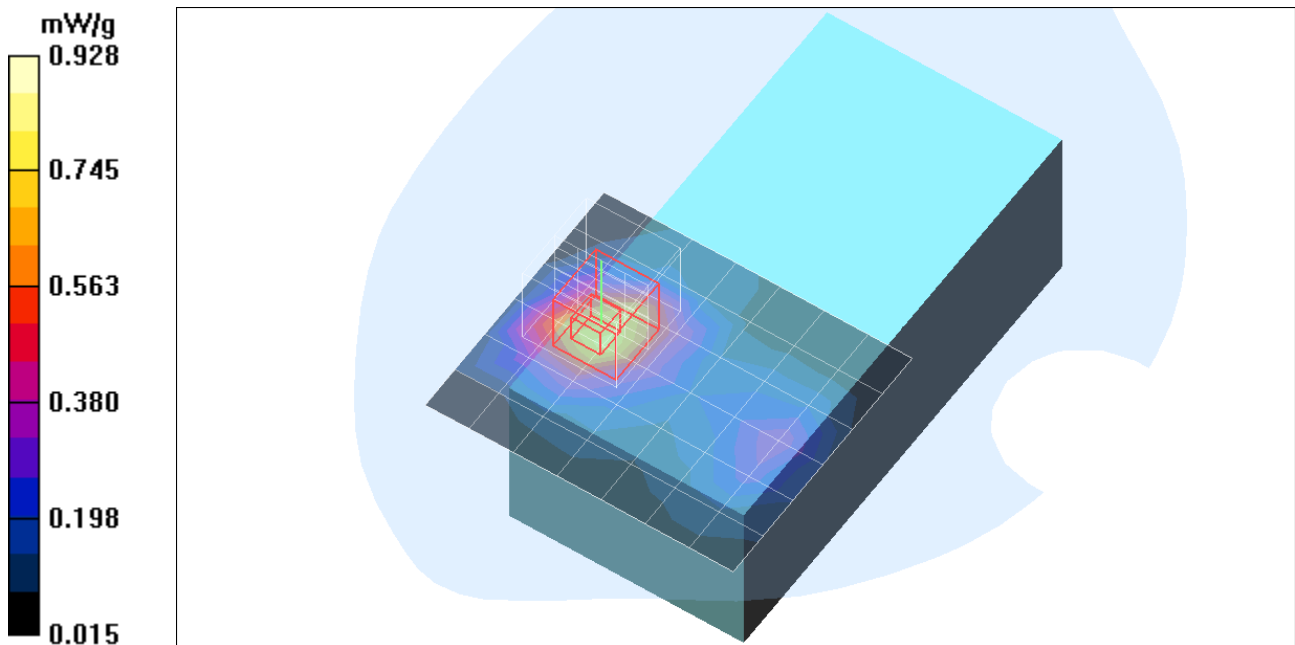

CDMA_BC1 Band

Frequency: 1880 MHz; Duty Cycle: 1:1

Bottom/Main Ant/CDMA_BC1/Ch 600_5mm Z Scan (1x1x21): Measurement grid: dx=20mm, dy=20mm, dz=5mm

[Info: Interpolated medium parameters used for SAR evaluation.](#)

Maximum value of SAR (measured) = 0.928 mW/g

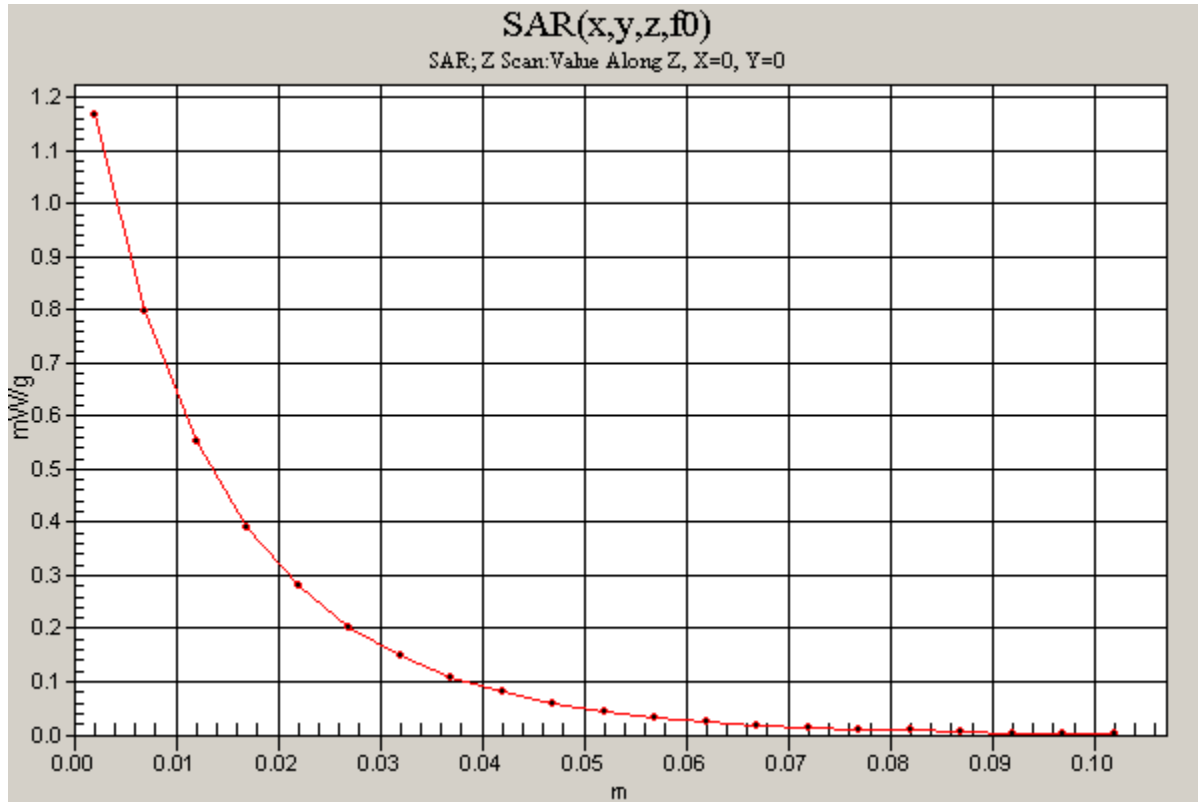

CDMA_BC1 Band

Frequency: 1851.25 MHz; Duty Cycle: 1:1; Room Ambient Temperature: 24.0°C; Liquid Temperature: 23.0°C

Medium parameters used: $f = 1851.7$ MHz; $\sigma = 1.51$ mho/m; $\epsilon_r = 54.2$; $\rho = 1000$ kg/m³ ;

DASY4 Configuration:

- Area Scan setting - Find Secondary Maximum Within: 2.0 dB and with a peak SAR value greater than 0.0012W/kg
- Electronics: DAE4 Sn558; Calibrated: 7/22/2014
- Probe: EX3DV4 - SN3554; ConvF(6.54, 6.54, 6.54); Calibrated: 9/24/2014
- Sensor-Surface: 2mm (Mechanical Surface Detection)
- Phantom: SAM 34-2; Type: SAM V4.0; Serial: TP-1150

Bottom/Main Ant/CDMA_BC1/Ch 25_5mm/Area Scan (8x7x1): Measurement grid: dx=15mm, dy=15mm

Maximum value of SAR (measured) = 0.749 mW/g

Bottom/Main Ant/CDMA_BC1/Ch 25_5mm/Zoom Scan (5x5x7)/Cube 0: Measurement grid: dx=8mm, dy=8mm, dz=5mm

Reference Value = 6.57 V/m; Power Drift = 0.127 dB

Peak SAR (extrapolated) = 1.09 W/kg

SAR(1 g) = 0.649 mW/g; SAR(10 g) = 0.369 mW/g

Maximum value of SAR (measured) = 0.872 mW/g

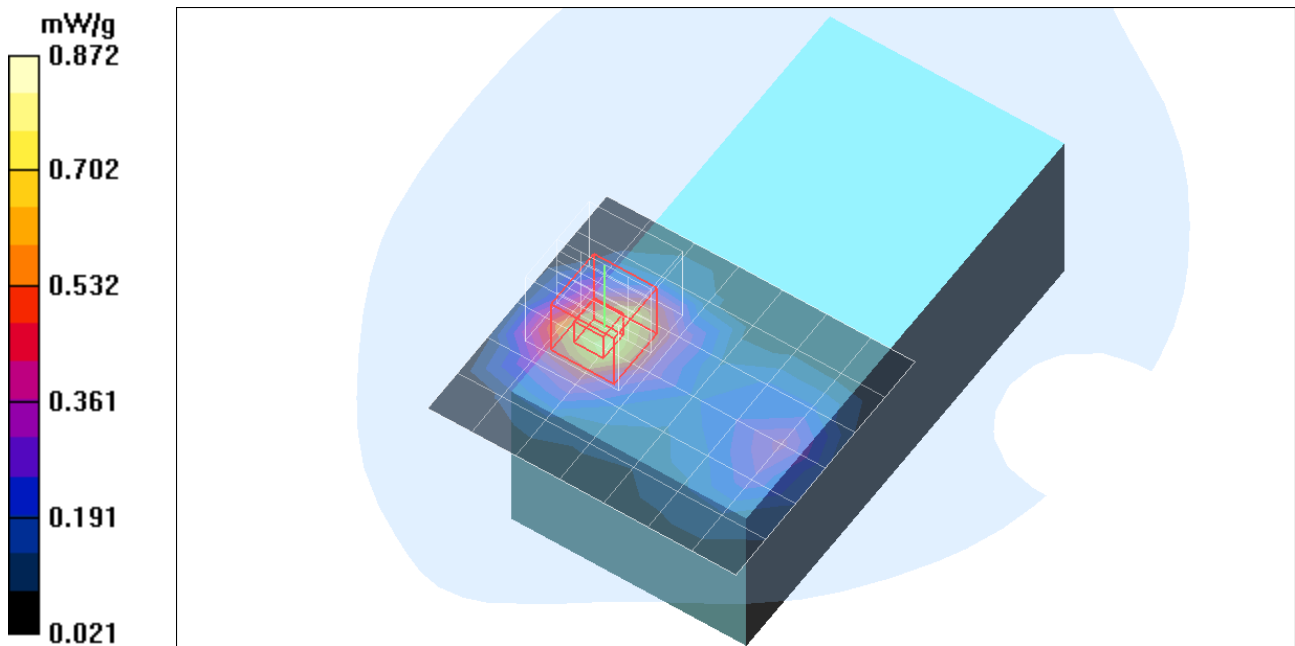

CDMA_BC1 Band

Frequency: 1908.75 MHz; Duty Cycle: 1:1; Room Ambient Temperature: 24.0°C; Liquid Temperature: 23.0°C

Medium parameters used (interpolated): $f = 1908.75$ MHz; $\sigma = 1.58$ mho/m; $\epsilon_r = 54$; $\rho = 1000$ kg/m³ ;

DASY4 Configuration:

- Area Scan setting - Find Secondary Maximum Within: 2.0 dB and with a peak SAR value greater than 0.0012W/kg
- Electronics: DAE4 Sn558; Calibrated: 7/22/2014
- Probe: EX3DV4 - SN3554; ConvF(6.54, 6.54, 6.54); Calibrated: 9/24/2014
- Sensor-Surface: 2mm (Mechanical Surface Detection)
- Phantom: SAM 34-2; Type: SAM V4.0; Serial: TP-1150

Bottom/Main Ant/CDMA_BC1/Ch 1175_5mm/Area Scan (8x7x1): Measurement grid: dx=15mm, dy=15mm

[Info: Interpolated medium parameters used for SAR evaluation.](#)

Maximum value of SAR (measured) = 0.622 mW/g

Bottom/Main Ant/CDMA_BC1/Ch 1175_5mm/Zoom Scan (5x5x7)/Cube 0: Measurement grid: dx=8mm, dy=8mm, dz=5mm

Reference Value = 6.50 V/m; Power Drift = -0.183 dB

Peak SAR (extrapolated) = 1.55 W/kg

SAR(1 g) = 0.650 mW/g; SAR(10 g) = 0.279 mW/g

[Info: Interpolated medium parameters used for SAR evaluation.](#)

Maximum value of SAR (measured) = 0.736 mW/g

