

TEST REPORT

CERTIFICATE OF CONFORMITY

Standard: 47 CFR FCC Part 15, Subpart E (Section 15.407)

Report No.: RFBBGM-WTW-P23070647-3

FCC ID: WIYSLM500QA

Product: Smart module

Brand:  **CASTLES
TECHNOLOGY**

Model No.: SLM500

Received Date: 2023/7/26

Test Date: 2023/8/10 ~ 2023/8/18

Issued Date: 2023/9/11

Applicant: CASTLES TECHNOLOGY CO., LTD.

Address: 6F, NO. 207-5, SEC. 3, BEIXIN RD., XINDIAN DISTRICT, NEW TAIPEI CITY 23143,
TAIWAN (R. O. C.)

Issued By: Bureau Veritas Consumer Products Services (H.K.) Ltd., Taoyuan Branch
Lin Kou Laboratories

Lab Address: No. 47-2, 14th Ling, Chia Pau Vil., Lin Kou Dist., New Taipei City, Taiwan

Test Location: No. 19, Hwa Ya 2nd Rd., Wen Hwa Vil., Kewi Shan Dist., Taoyuan City 33383, Taiwan

FCC Registration / 788550 / TW0003

Designation Number:

Approved by:

Jeremy Lin

Date:

2023/9/11

Jeremy Lin / Project Engineer

This test report consists of 52 pages in total. It may be duplicated completely for legal use with the approval of the applicant. It should not be reproduced except in full, without the written approval of our laboratory. The test results in the report only apply to the tested sample. The test results in this report are traceable to the national or international standards.



Prepared by : Gina Liu / Specialist

This report is governed by, and incorporates by reference, the Conditions of Testing as posted at the date of issuance of this report at <http://www.bureauveritas.com/home/about-us/our-business/cps/about-us/terms-conditions/> and is intended for your exclusive use. Any copying or replication of this report to or for any other person or entity, or use of our name or trademark, is permitted only with our prior written permission. This report sets forth our findings solely with respect to the test samples identified herein. The results set forth in this report are not indicative or representative of the quality or characteristics of the lot from which a test sample was taken or any similar or identical product unless specifically and expressly noted. Our report includes all of the tests requested by you and the results thereof based upon the information that you provided to us. Measurement uncertainty is only provided upon request for accredited tests. Statements of conformity are based on simple acceptance criteria without taking measurement uncertainty into account, unless otherwise requested in writing. You have 60 days from date of issuance of this report to notify us of any material error or omission caused by our negligence or if you require measurement uncertainty; provided, however, that such notice shall be in writing and shall specifically address the issue you wish to raise. A failure to raise such issue within the prescribed time shall constitute your unqualified acceptance of the completeness of this report, the tests conducted and the correctness of the report contents.

Table of Contents

Release Control Record	3
1 Certificate.....	4
2 Summary of Test Results	5
2.1 Measurement Uncertainty	5
2.2 Supplementary Information	5
3 General Information	6
3.1 General Description of EUT	6
3.2 Antenna Description of EUT	7
3.3 Channel List.....	7
3.4 Test Mode Applicability and Tested Channel Detail.....	8
3.5 Duty Cycle of Test Signal.....	9
3.6 Test Program Used and Operation Descriptions	10
3.7 Connection Diagram of EUT and Peripheral Devices	10
3.8 Configuration of Peripheral Devices and Cable Connections	10
4 Test Instruments	11
4.1 RF Output Power.....	11
4.2 AC Power Conducted Emissions	11
4.3 Unwanted Emissions below 1 GHz	12
4.4 Unwanted Emissions above 1 GHz.....	13
5 Limits of Test Items.....	14
5.1 RF Output Power.....	14
5.2 AC Power Conducted Emissions	14
5.3 Unwanted Emissions below 1 GHz	14
5.4 Unwanted Emissions above 1 GHz.....	15
6 Test Arrangements.....	16
6.1 RF Output Power.....	16
6.1.1 Test Setup	16
6.1.2 Test Procedure.....	16
6.2 AC Power Conducted Emissions	16
6.2.1 Test Setup	16
6.2.2 Test Procedure.....	16
6.3 Unwanted Emissions below 1 GHz	17
6.3.1 Test Setup	17
6.3.2 Test Procedure.....	18
6.4 Unwanted Emissions above 1 GHz.....	19
6.4.1 Test Setup	19
6.4.2 Test Procedure.....	19
7 Test Results of Test Item	20
7.1 RF Output Power.....	20
7.2 AC Power Conducted Emissions	22
7.3 Unwanted Emissions below 1 GHz	24
7.4 Unwanted Emissions above 1 GHz.....	26
8 Pictures of Test Arrangements	51
9 Information of the Testing Laboratories	52



Release Control Record

Issue No.	Description	Date Issued
RFBBGM-WTW-P23070647-3	Original release.	2023/9/11

1 Certificate

Product: Smart module

Brand:  **CASTLES
TECHNOLOGY**

Test Model: SLM500

Sample Status: Identical Prototype

Applicant: CASTLES TECHNOLOGY CO., LTD.

Test Date: 2023/8/10 ~ 2023/8/18

Standard: 47 CFR FCC Part 15, Subpart E (Section 15.407)

Measurement procedure: ANSI C63.10-2013
KDB 789033 D02 General UNII Test Procedure New Rules v02r01

The above equipment has been tested by **Bureau Veritas Consumer Products Services (H.K.) Ltd., Taoyuan Branch**, and found compliance with the requirement of the above standards. The test record, data evaluation & Equipment Under Test (EUT) configurations represented herein are true and accurate accounts of the measurements of the sample's RF characteristics under the conditions specified in this report.

2 Summary of Test Results

47 CFR FCC Part 15, Subpart E (Section 15.407)			
Clause	Test Item	Result	Remark
15.407(a)(2)	26 dB Bandwidth	NA	Refer to Note
15.407(a)(1) 15.407(a)(3)	RF Output Power	Pass	Meet the requirement of limit.
15.407(a)(1) 15.407(a)(3)	Power Spectral Density	NA	Refer to Note
15.407(e)	6 dB Bandwidth	NA	Refer to Note
---	Occupied Bandwidth	NA	Refer to Note
15.407(g)	Frequency Stability	NA	Refer to Note
15.407(b)(9)	AC Power Conducted Emissions	Pass	Minimum passing margin is -8.41 dB at 0.40180 MHz
15.407(b)(9)	Unwanted Emissions below 1 GHz	Pass	Minimum passing margin is -8.6 dB at 83.75 MHz
15.407(b) (1/10) 15.407(b) (4(i)/10)	Unwanted Emissions above 1 GHz	Pass	Minimum passing margin is -1.0 dB at 5150.00 MHz
15.203	Antenna Requirement	Pass	Antenna connector is ipex(MHF) not a standard connector.

Notes:

1. This report is prepared for FCC class II permissive change. Therefore, only test item RF Output Power / AC Power Conducted Emissions and Radiated Spurious Emissions were performed for this report. Other testing data please refer to SGS report no.: SZCR210300003004.
2. Determining compliance based on the results of the compliance measurement, not taking into account measurement instrumentation uncertainty.

2.1 Measurement Uncertainty

Where relevant, the following measurement uncertainty levels have been estimated for tests performed on the EUT as specified in CISPR 16-4-2:

Measurement	Specification	Expanded Uncertainty (k=2) (±)
AC Power Conducted Emissions	9 kHz ~ 30 MHz	2.99 dB
Unwanted Emissions below 1 GHz	9 kHz ~ 30 MHz	2.44 dB
	30 MHz ~ 1 GHz	2.02 dB
Unwanted Emissions above 1 GHz	1 GHz ~ 18 GHz	1.01 dB
	18 GHz ~ 40 GHz	1.15 dB

The other instruments specified are routine verified to remain within the calibrated levels, no measurement uncertainty is required to be calculated.

2.2 Supplementary Information

There is not any deviation from the test standards for the test method, and no modifications required for compliance.

3 General Information

3.1 General Description of EUT

Product	Smart module
Brand	 CASTLES TECHNOLOGY
Test Model	SLM500
Status of EUT	Identical Prototype
Power Supply Rating	Refer to note
Modulation Type	64QAM, 16QAM, QPSK, BPSK for OFDM
Modulation Technology	OFDM
Transfer Rate	802.11a: 54/48/36/24/18/12/9/6Mbps 802.11n: up to 150Mbps
Operating Frequency	5.18 GHz ~ 5.24 GHz 5.745 GHz ~ 5.825 GHz
Number of Channel	802.11a, 802.11n (HT20): 9 802.11n (HT40): 4
Output Power	5.18 GHz ~ 5.24 GHz : 23.121 mW (13.64 dBm) 5.745 GHz ~ 5.825 GHz : 26.669 mW (14.26 dBm)
EUT Category	Client device

Note:

1. The EUT uses following accessories.

AC Adapter		
Brand	Model	Specification
ABP	ABP AD0181-1201000UC	AC Input : 100-240Vac, 50-60Hz, 0.5A Max DC Output : 12.0Vdc, 1.0A, 12.0W Plug : US Plug Manufacturer : SHENZHEN ABP TECHNOLOGY CO., LTD
1 To 3 Cable		
Brand	Model	Specification
CHANG YANG	cy-as-hk0109	2.02M

2. The EUT is authorized for use in specific End-product. Please refer to below table for more details.

Product Name	Brand Name	Model No.
POS Terminal	 CASTLES TECHNOLOGY	S1P

3. Simultaneously transmission condition.

Condition	Technology		
1	WWAN	WLAN	NFC
2	WWAN	Bluetooth	NFC

Note: The emission of the simultaneous operation has been evaluated and no non-compliance was found.

4. The above EUT information is declared by manufacturer and for more detailed features description, please refers to the manufacturer's specifications or user's manual.

3.2 Antenna Description of EUT

1. The antenna information is listed as below.

Antenna No.	Gain (dBi)	Antenna Type	Connector Type
	5150-5850 MHz		
1	2.69	PIFA	ipex(MHF)

* Detail antenna specification please refer to antenna datasheet and/or antenna measurement report.

2. The EUT incorporates a SISO function:

5 GHz Band		
Modulation Mode	TX & RX Configuration	
802.11a	1TX	1RX
802.11n (HT20)	1TX	1RX
802.11n (HT40)	1TX	1RX

3.3 Channel List

FOR 5180 ~ 5240 MHz

4 channels are provided for 802.11a, 802.11n (HT20):

Channel	Frequency	Channel	Frequency
36	5180 MHz	44	5220 MHz
40	5200 MHz	48	5240 MHz

2 channels are provided for 802.11n (HT40):

Channel	Frequency	Channel	Frequency
38	5190 MHz	46	5230 MHz

FOR 5745 ~ 5825 MHz:

5 channels are provided for 802.11a, 802.11n (HT20):

Channel	Frequency	Channel	Frequency
149	5745 MHz	161	5805 MHz
153	5765 MHz	165	5825 MHz
157	5785 MHz		

2 channels are provided for 802.11n (HT40):

Channel	Frequency	Channel	Frequency
151	5755 MHz	159	5795 MHz

3.4 Test Mode Applicability and Tested Channel Detail

Pre-Scan:	1. EUT can be used in the following ways: X-axis/ Y-axis/ Z-axis. Pre-scan these ways and find the worst case as a representative test condition.
Worst Case:	1. X-axis/ Y-axis/ Z-axis Worst Condition: Z-axis

Following channel(s) was (were) selected for the final test as listed below:

Test Item	Mode	Signal Mode	Tested Channel	Modulation	Data Rate Parameter
RF Output Power	802.11a	CDD	36, 40, 48, 149, 157, 165	BPSK	6Mb/s
	802.11n (HT20)	CDD	36, 40, 48, 149, 157, 165	BPSK	MCS0
	802.11n (HT40)	CDD	38, 46, 151, 159	BPSK	MCS0
AC Power Conducted Emissions	802.11a	CDD	157	BPSK	6Mb/s
Unwanted Emissions below 1 GHz	802.11a	CDD	157	BPSK	6Mb/s
Unwanted Emissions above 1 GHz	802.11a	CDD	36, 40, 48, 149, 157, 165	BPSK	6Mb/s
	802.11n (HT20)	CDD	36, 40, 48, 149, 157, 165	BPSK	MCS0
	802.11n (HT40)	CDD	38, 46, 151, 159	BPSK	MCS0

3.5 Duty Cycle of Test Signal

802.11a: Duty cycle = 1.368 ms / 1.371 ms x 100% = 99.8%

802.11n (HT20): Duty cycle = 1.278 ms / 1.281 ms x 100% = 99.8%

802.11n (HT40): Duty cycle = 0.639 ms / 0.642 ms x 100% = 99.5%

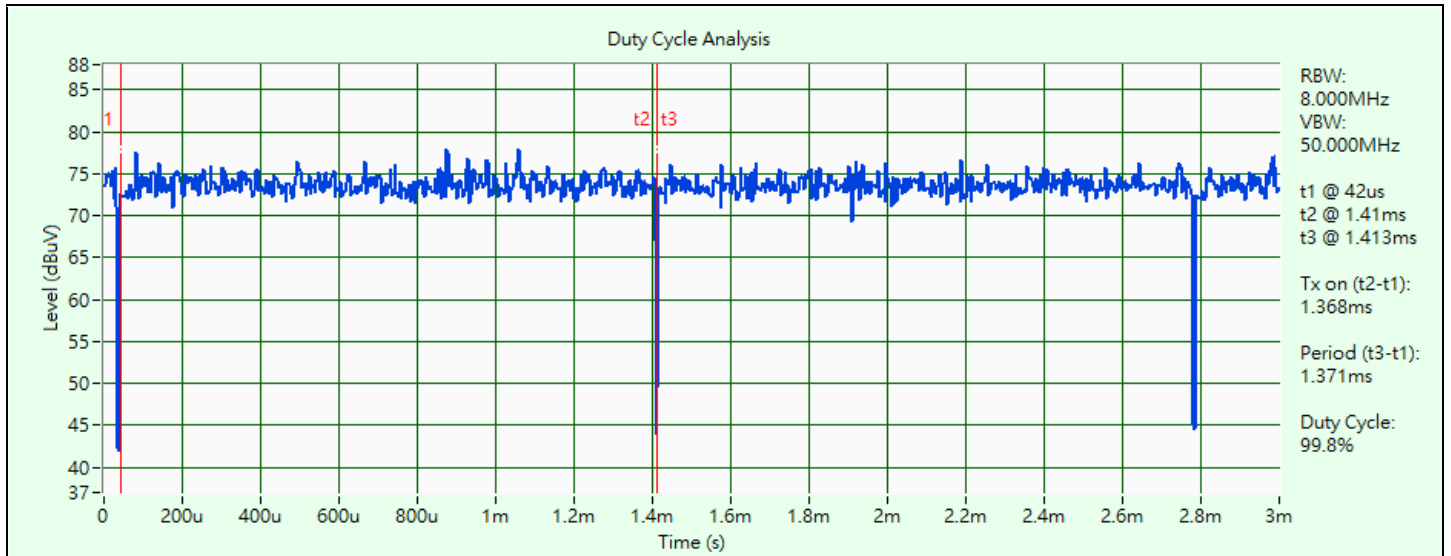

802.11a

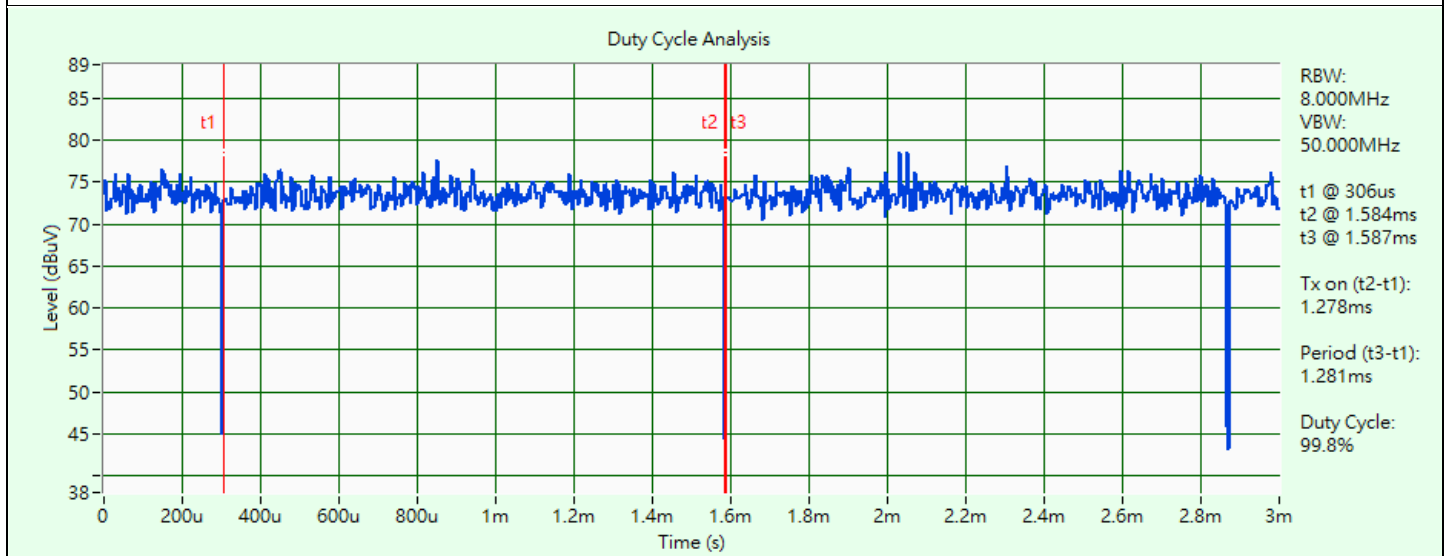

802.11n (HT20)

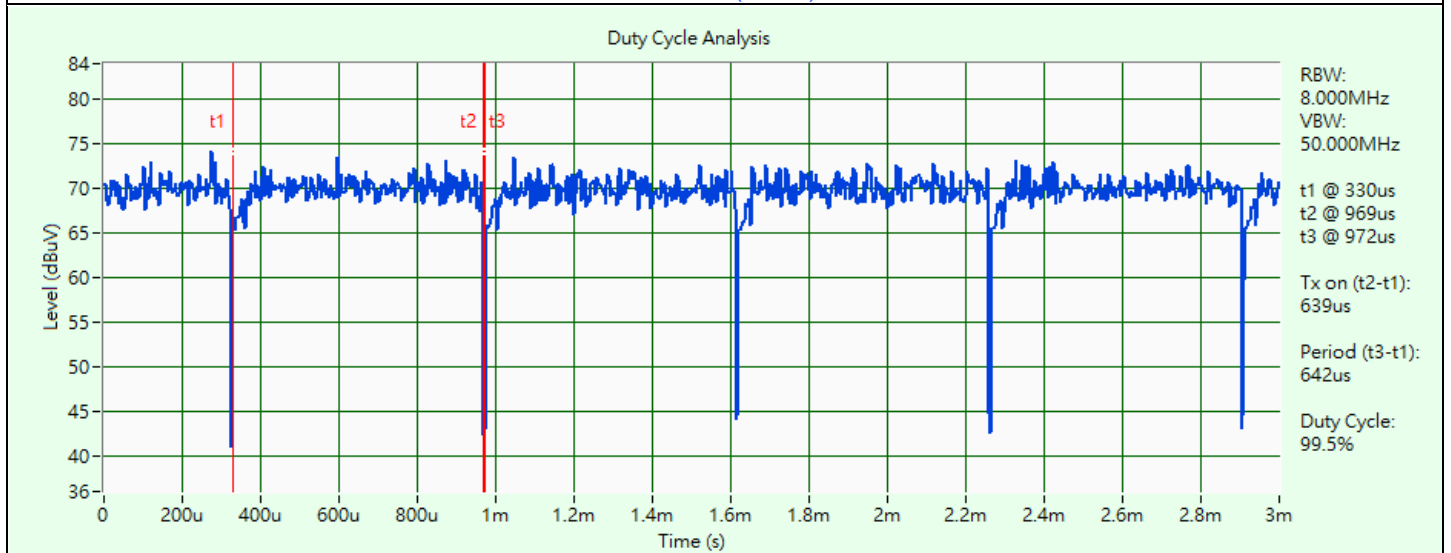

802.11n (HT40)

3.6 Test Program Used and Operation Descriptions

Controlling software QRCT v3.0.0.264 has been activated to set the EUT under transmission condition continuously at specific channel frequency.

3.7 Connection Diagram of EUT and Peripheral Devices

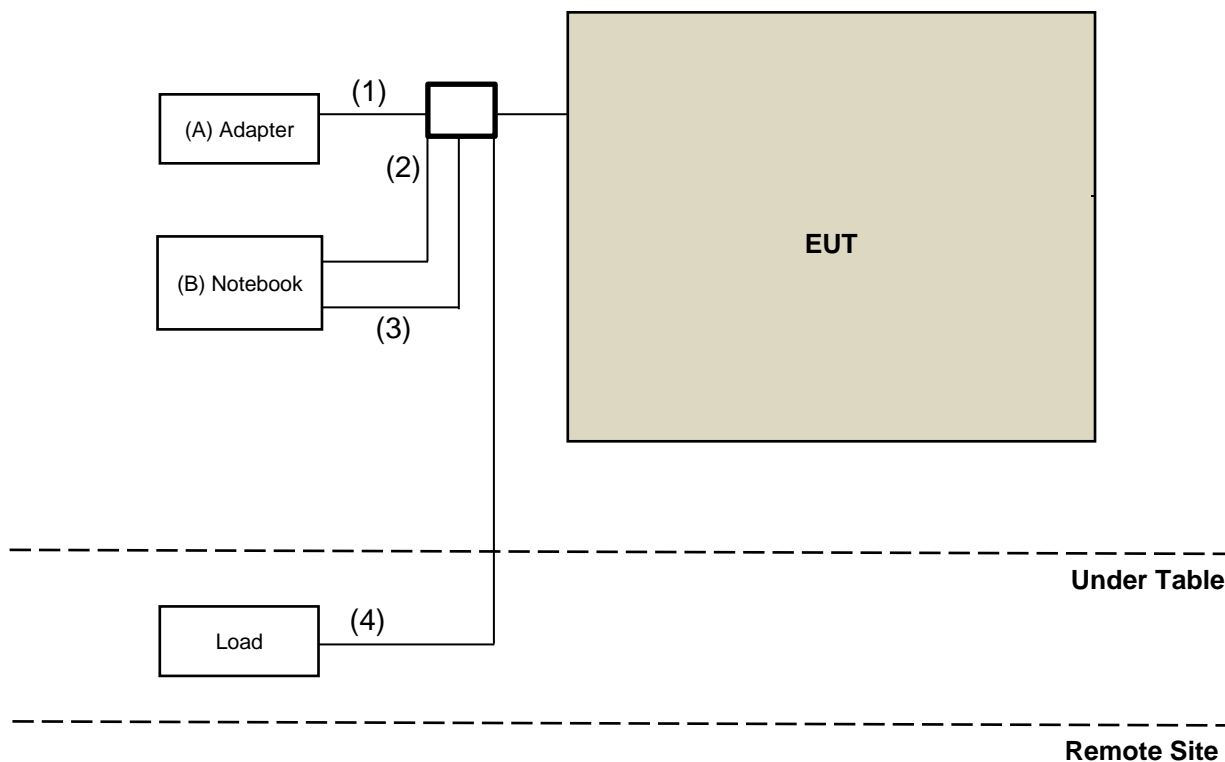

3.8 Configuration of Peripheral Devices and Cable Connections

ID	Product	Brand	Model No.	Serial No.	FCC ID	Remarks
A	Adapter	ABP	ABP AD0181-1201000UC	NA	NA	Supplied by applicant
B	Notebook	Lenono	TP00048A	NA	NA	Provided by Lab

ID	Cable Descriptions	Qty.	Length (m)	Shielding (Yes/No)	Cores (Qty.)	Remarks
1	1 to 3 Cable	1	2.02	YES	0	Supplied by applicant
2	RS232 to USB	1	1.2	YES	0	Supplied by applicant
3	USB Cable	1	1.8	YES	0	Supplied by applicant
4	LAN Cable	1	1.8	YES	0	Provided by Lab

4 Test Instruments

The calibration interval of the all test instruments are 12 months and the calibrations are traceable to NML/ROC and NIST/USA.

4.1 RF Output Power

Description Manufacturer	Model No.	Serial No.	Calibrated Date	Calibrated Until
Peak Power Analyzer Keysight	8990B	MY51000485	2023/1/19	2024/1/18
Wideband Power Sensor Keysight	N1923A	MY58020002	2023/1/18	2024/1/17
		MY58140009	2023/1/18	2024/1/17

Notes:

1. The test was performed in Oven room.
2. Tested Date: 2023/8/18

4.2 AC Power Conducted Emissions

Description Manufacturer	Model No.	Serial No.	Calibrated Date	Calibrated Until
EMI Test Receiver R&S	ESCI	100613	2022/12/5	2023/12/4
LISN R&S	ENV216	101826	2023/3/23	2024/3/22
	ESH3-Z5	100311	2022/9/12	2023/9/11
RF Coaxial Cable Woken	5D-FB	Cable-cond1-01	2023/1/7	2024/1/6
Software BVADT	BVADT_Cond_ V7.3.7.4	N/A	N/A	N/A
V-LISN Schwarzbeck	NNBL 8226-2	8226-142	2022/8/31	2023/8/30

Notes:

1. The test was performed in HY - Conduction 1.
2. Tested Date: 2023/8/18

4.3 Unwanted Emissions below 1 GHz

Description Manufacturer	Model No.	Serial No.	Calibrated Date	Calibrated Until
Antenna Tower Max-Full	UNAT_5+	PAD-CH6-01	N/A	N/A
Antenna Tower Controller Max-Full	MF-7802	N/A	N/A	N/A
Bi_Log Antenna Schwarzbeck	VULB 9168	9168-616	2022/10/26	2023/10/25
Loop Antenna Electro-Metrics	EM-6879	269	2022/9/19	2023/9/18
Loop Antenna TESEQ	HLA 6121	45745	2023/8/8	2024/8/7
MXE EMI Receiver Agilent	N9038A	MY52260177	2022/9/19	2023/9/18
Preamplifier Agilent	310N	187226	2023/6/13	2024/6/12
Preamplifier EMCI	EMC001340	980201	2022/9/23	2023/9/22
RF Coaxial Cable EMCI	5D-NM-BM	140903+140902	2023/1/7	2024/1/6
RF Coaxial Cable ETS-Lindgren	EMC104-SM-SM-10000	Cable-CH1-01(RFC-SMS-100-SMS-120+RFC-SMS-100-SMS-4)	2023/6/13	2024/6/12
	RFC-SMS-100-SMS-24-IN	Cable-CH1-02(RFC-SMS-100-SMS-24)	2023/6/13	2024/6/12
Software BV ADT	ADT_Radiated_ V7.6.15.9.5	N/A	N/A	N/A
Turn Table Max-Full	TT-1510	N/A	N/A	N/A
Turn Table Controller Max-Full	MF-7802	N/A	N/A	N/A

Notes:

1. The test was performed in XD - 966 chamber 6.
2. Tested Date: 2023/8/15

4.4 Unwanted Emissions above 1 GHz

Description Manufacturer	Model No.	Serial No.	Calibrated Date	Calibrated Until
Antenna Tower Max-Full	UNAT_5+	PAD-CH6-01	N/A	N/A
Antenna Tower Controller Max-Full	MF-7802	N/A	N/A	N/A
Boresight antenna tower fixture BV	BAF-02	8	N/A	N/A
Horn Antenna ETS-Lindgren	3117	00143293	2022/11/13	2023/11/12
Horn Antenna Schwarzbeck	BBHA 9170	BBHA9170241	2022/10/20	2023/10/19
MXE EMI Receiver Agilent	N9038A	MY52260177	2022/9/19	2023/9/18
Preamplifier Agilent	83017A	MY39501373	2023/6/13	2024/6/12
Preamplifier EMCI	EMC 184045	980116	2022/10/1	2023/9/30
RF Coaxial Cable ETS-Lindgren	EMC104-SM-SM-10000	Cable-CH1-01(RFC-SMS-100-SMS-120+RFC-SMS-100-SMS-4)	2023/6/13	2024/6/12
	RFC-SMS-100-SMS-24-IN	Cable-CH1-02(RFC-SMS-100-SMS-24)	2023/6/13	2024/6/12
RF Coaxial Cable HUBER+SUHNER	SUCOFLEX 104	CABLE-CH9-(250795/4)	2023/1/7	2024/1/6
RF Coaxial Cable HUBER+SUHNER&EMCI	SUCOFLEX 104& EMC104-SM-SM8000	CABLE-CH9-02 (248780+171006)	2023/1/7	2024/1/6
Software BV ADT	ADT_Radiated_ V7.6.15.9.5	N/A	N/A	N/A
Turn Table Max-Full	TT-1510	N/A	N/A	N/A
Turn Table Controller Max-Full	MF-7802	N/A	N/A	N/A

Notes:

1. The test was performed in XD - 966 chamber 6.
2. Tested Date: 2023/8/10 ~ 2023/8/11

5 Limits of Test Items

5.1 RF Output Power

Operation Band	EUT Category	Limit
U-NII-1	Outdoor Access Point	1 Watt (30 dBm) (Max. e.i.r.p \leq 125mW(21 dBm) at any elevation angle above 30 degrees as measured from the horizon)
	Fixed point-to-point Access Point	1 Watt (30 dBm)
	Indoor Access Point	1 Watt (30 dBm)
	Mobile and Portable client device	250mW (24 dBm)

Operation Band	Limit
U-NII-3	1 Watt (30 dBm)

5.2 AC Power Conducted Emissions

Frequency (MHz)	Conducted Limit (dBuV)	
	Quasi-peak	Average
0.15 - 0.5	66 - 56	56 - 46
0.50 - 5.0	56	46
5.0 - 30.0	60	50

Notes:

1. The lower limit shall apply at the transition frequencies.
2. The limit decreases in line with the logarithm of the frequency in the range of 0.15 to 0.50 MHz.

5.3 Unwanted Emissions below 1 GHz

Radiated emissions which fall in the restricted bands must comply with the radiated emission limits specified as below table.

Frequencies (MHz)	Field Strength (microvolts/meter)	Measurement Distance (meters)
0.009 ~ 0.490	2400/F(kHz)	300
0.490 ~ 1.705	24000/F(kHz)	30
1.705 ~ 30.0	30	30
30 ~ 88	100	3
88 ~ 216	150	3
216 ~ 960	200	3
Above 960	500	3

Notes:

1. The lower limit shall apply at the transition frequencies.
2. Emission level (dBuV/m) = 20 log Emission level (uV/m).

5.4 Unwanted Emissions above 1 GHz

Radiated emissions which fall in the restricted bands must comply with the radiated emission limits specified as below table.

Frequencies (MHz)	Field Strength (microvolts/meter)	Measurement Distance (meters)
Above 960	500	3

Notes:

1. The lower limit shall apply at the transition frequencies.
2. Emission level (dBuV/m) = 20 log Emission level (uV/m).
3. For frequencies above 1000 MHz, the field strength limits are based on average detector, however, the peak field strength of any emission shall not exceed the maximum permitted average limits, specified above by more than 20 dB under any condition of modulation.

Limits of unwanted emission out of the restricted bands

Applicable To	Limit	
789033 D02 General UNII Test Procedure New Rules v02r01	Field Strength at 3 m	
	PK: 74 (dBµV/m)	AV: 54 (dBµV/m)

For transmitters operating in the 5.15-5.25 GHz band:

Applicable To	EIRP Limit	Equivalent Field Strength at 3 m
15.407(b)(1)	PK: -27 (dBm/MHz)	PK: 68.2 (dBµV/m)

For transmitters operating in the 5.725-5.850 GHz band:

Applicable To	EIRP Limit	Equivalent Field Strength at 3 m
15.407(b)(4)(i)	PK: -27 (dBm/MHz) ^{*1} PK: 10 (dBm/MHz) ^{*2} PK: 15.6 (dBm/MHz) ^{*3} PK: 27 (dBm/MHz) ^{*4}	PK: 68.2 (dBµV/m) ^{*1} PK: 105.2 (dBµV/m) ^{*2} PK: 110.8 (dBµV/m) ^{*3} PK: 122.2 (dBµV/m) ^{*4}

^{*1} beyond 75 MHz or more above of the band edge.

^{*2} below the band edge increasing linearly to 10 dBm/MHz at 25 MHz above.

^{*3} below the band edge increasing linearly to a level of 15.6 dBm/MHz at 5 MHz above.

^{*4} from 5 MHz above or below the band edge increasing linearly to a level of 27 dBm/MHz at the band edge.

Note: The following formula is used to convert the equipment isotropic radiated power (eirp) to field strength:

$$E = \frac{1000000\sqrt{30P}}{3} \mu\text{V/m, where P is the eirp (Watts).}$$

6 Test Arrangements

6.1 RF Output Power

6.1.1 Test Setup

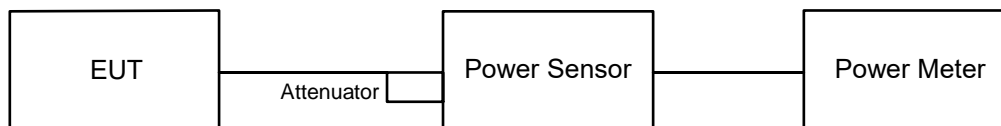

6.1.2 Test Procedure

Method PM is used to perform output power measurement, trigger and gating function of wide band power meter is enabled to measure max output power of TX on burst and set the detector to average. Duty factor is not added to measured value.

6.2 AC Power Conducted Emissions

6.2.1 Test Setup

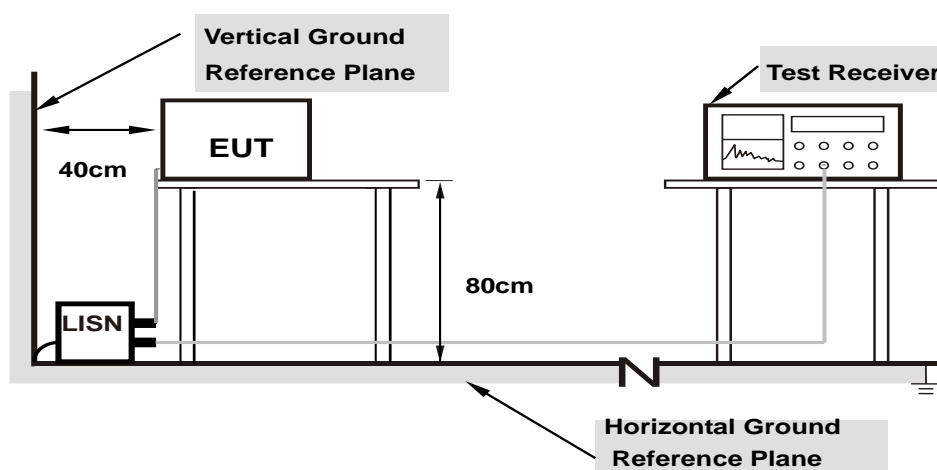

Note: 1.Support units were connected to second LISN.

For the actual test configuration, please refer to the attached file (Test Setup Photo).

6.2.2 Test Procedure

- The EUT was placed on a 0.8 meter to the top of table and placed 0.4 meters from the conducting wall of the shielded room with EUT being connected to the power mains through a line impedance stabilization network (LISN). Other support units were connected to the power mains through another LISN. The two LISNs provide 50 ohm/ 50 uH of coupling impedance for the measuring instrument.
- Both lines of the power mains connected to the EUT were checked for maximum conducted interference.
- The frequency range from 150 kHz to 30 MHz was searched. Emission levels under (Limit – 20 dB) was not recorded.

Note: The resolution bandwidth and video bandwidth of test receiver is 9 kHz for quasi-peak detection (QP) and average detection (AV) at frequency 0.15 MHz-30 MHz.

6.3 Unwanted Emissions below 1 GHz

6.3.1 Test Setup

For Radiated emission below 30 MHz

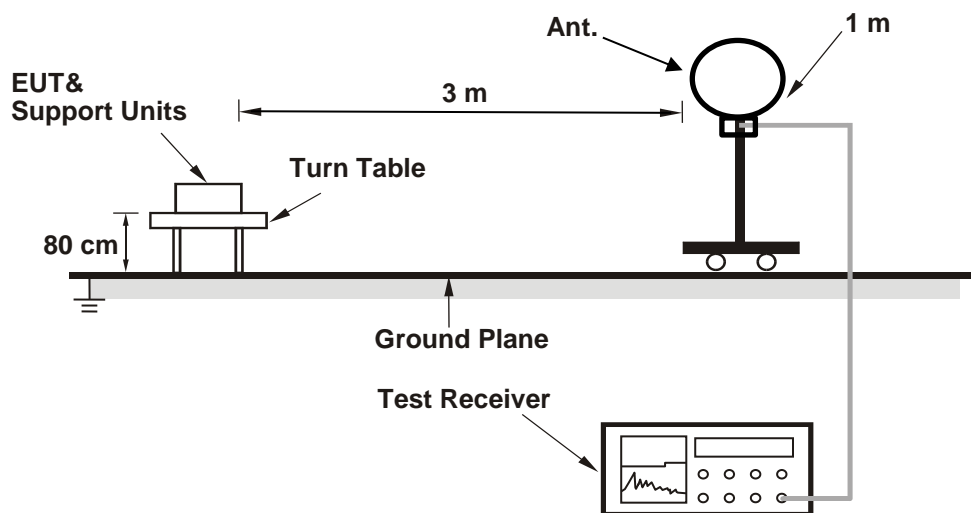

For Radiated emission above 30 MHz

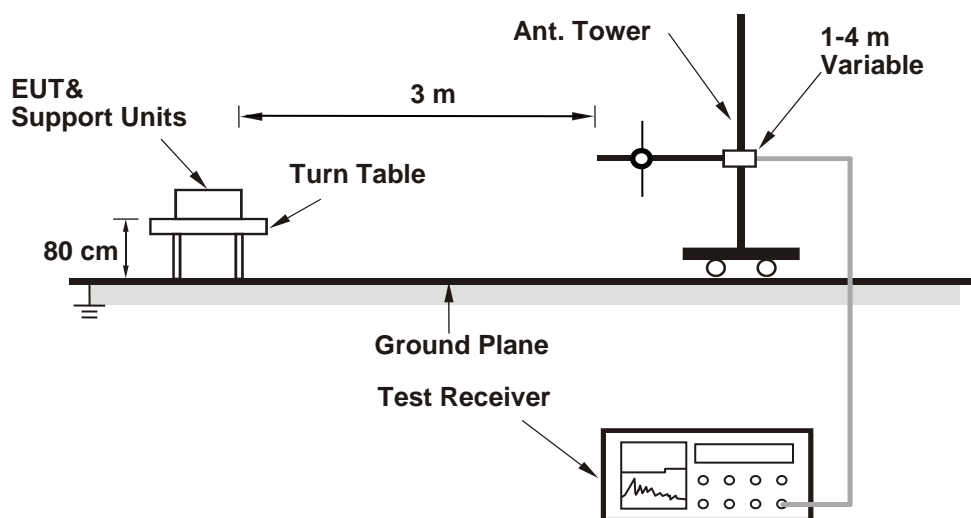

For the actual test configuration, please refer to the attached file (Test Setup Photo).

6.3.2 Test Procedure

For Radiated emission below 30 MHz

- a. The EUT was placed on the top of a rotating table 0.8 meters above the ground at 3 meter chamber room for test. The table was rotated 360 degrees to determine the position of the highest radiation.
- b. The EUT was set 3 meters away from the interference-receiving antenna, which was mounted on the top of a variable-height antenna tower.
- c. Parallel, perpendicular, and ground-parallel orientations of the antenna are set to make the measurement.
- d. For each suspected emission, the EUT was arranged to its worst case and the rotatable table was turned from 0 degrees to 360 degrees to find the maximum reading.
- e. The test-receiver system was set to Quasi-Peak Detect Function and Specified Bandwidth with Maximum Hold Mode, except for the frequency band (9 kHz to 90 kHz and 110 kHz to 490 kHz) set to average detect function and peak detect function.

Notes:

1. The resolution bandwidth and video bandwidth of test receiver/spectrum analyzer is 200 Hz at frequency below 150 kHz.
2. The resolution bandwidth and video bandwidth of test receiver/spectrum analyzer is 9 kHz or 10 kHz at frequency (150 kHz to 30 MHz).
3. All modes of operation were investigated and the worst-case emissions are reported.

For Radiated emission above 30 MHz

- a. The EUT was placed on the top of a rotating table 0.8 meters above the ground at 3 meter chamber room for test. The table was rotated 360 degrees to determine the position of the highest radiation.
- b. The EUT was set 3 meters away from the interference-receiving antenna, which was mounted on the top of a variable-height antenna tower.
- c. The height of antenna is varied from one meter to four meters above the ground to determine the maximum value of the field strength. Both horizontal and vertical polarizations of the antenna are set to make the measurement.
- d. For each suspected emission, the EUT was arranged to its worst case and then the antenna was tuned to heights from 1 meter to 4 meters and the rotatable table was turned from 0 degrees to 360 degrees to find the maximum reading.
- e. The test-receiver system was set to Quasi-peak(QP) detect function, Average(AV) detect function, Peak(PK) detect function and specified bandwidth with maximum hold mode when the test frequency is below 1 GHz.

Notes:

1. The resolution bandwidth and video bandwidth of test receiver/spectrum analyzer is 120 kHz for Quasi-peak detection (QP), Average detection (AV), Peak detection (PK) at frequency (30MHz to 1 GHz).
2. All modes of operation were investigated and the worst-case emissions are reported.

6.4 Unwanted Emissions above 1 GHz

6.4.1 Test Setup

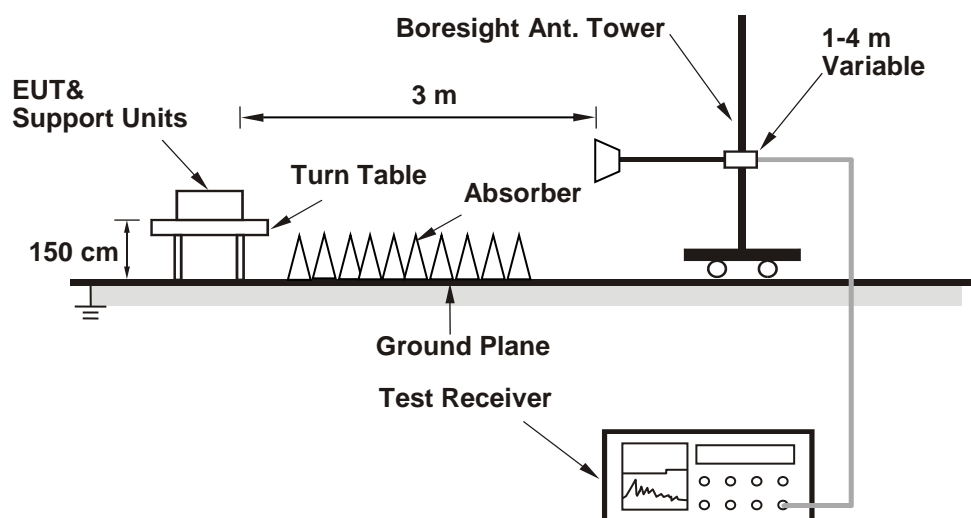

For the actual test configuration, please refer to the attached file (Test Setup Photo).

6.4.2 Test Procedure

- The EUT was placed on the top of a rotating table 1.5 meters above the ground at 3 meter chamber room for test. The table was rotated 360 degrees to determine the position of the highest radiation.
- The EUT was set 3 meters away from the interference-receiving antenna, which was mounted on the top of a variable-height antenna tower.
- The height of antenna is varied from one meter to four meters above the ground to determine the maximum value of the field strength. Both horizontal and vertical polarizations of the antenna are set to make the measurement.
- For each suspected emission, the EUT was arranged to its worst case and then the antenna was tuned to heights from 1 meter to 4 meters and the rotatable table was turned from 0 degrees to 360 degrees to find the maximum reading.
- The test-receiver system was set to peak and average detects function and specified bandwidth with maximum hold mode when the test frequency is above 1 GHz. If the peak reading value also meets average limit, measurement with the average detector is unnecessary.

Notes:

- The resolution bandwidth of test receiver/spectrum analyzer is 1 MHz and the video bandwidth is 3 MHz for Peak detection (PK) and Average detection (AV) at frequency above 1 GHz.
- For fundamental and harmonic signal measurement, the resolution bandwidth of test receiver/spectrum analyzer is 1 MHz and the video bandwidth is $\geq 1/T$ (Duty cycle $< 98\%$) or 10 Hz (Duty cycle $\geq 98\%$) for Average detection (AV) at frequency above 1 GHz.
- All modes of operation were investigated and the worst-case emissions are reported.

7 Test Results of Test Item

7.1 RF Output Power

Input Power:	120 Vac, 60 Hz	Environmental Conditions:	25°C, 60% RH	Tested By:	Ted Chang
--------------	----------------	---------------------------	--------------	------------	-----------

802.11a

Chan.	Chan. Freq. (MHz)	Average Power (mW)	Average Power (dBm)	Power Limit (dBm)	Test Result
36	5180	22.594	13.54	24	Pass
40	5200	22.029	13.43	24	Pass
48	5240	23.121	13.64	24	Pass
149	5745	20.559	13.13	30	Pass
157	5785	26.669	14.26	30	Pass
165	5825	20.797	13.18	30	Pass

Notes:

1. For U-NII-1, the antenna gain is 2.69 dBi < 6 dBi, so the output power limit shall not be reduced.
2. For U-NII-3, the antenna gain is 2.69 dBi < 6 dBi, so the output power limit shall not be reduced.

802.11n (HT20)

Chan.	Chan. Freq. (MHz)	Average Power (mW)	Average Power (dBm)	Power Limit (dBm)	Test Result
36	5180	22.909	13.60	24	Pass
40	5200	21.878	13.40	24	Pass
48	5240	22.909	13.60	24	Pass
149	5745	25.061	13.99	30	Pass
157	5785	26.182	14.18	30	Pass
165	5825	20.749	13.17	30	Pass

Notes:

1. For U-NII-1, the antenna gain is 2.69 dBi < 6 dBi, so the output power limit shall not be reduced.
2. For U-NII-3, the antenna gain is 2.69 dBi < 6 dBi, so the output power limit shall not be reduced.

802.11n (HT40)

Chan.	Chan. Freq. (MHz)	Average Power (mW)	Average Power (dBm)	Power Limit (dBm)	Test Result
38	5190	8.511	9.30	24	Pass
46	5230	20.277	13.07	24	Pass
151	5755	24.434	13.88	30	Pass
159	5795	23.121	13.64	30	Pass

Notes:

1. For U-NII-1, the antenna gain is 2.69 dBi < 6 dBi, so the output power limit shall not be reduced.
2. For U-NII-3, the antenna gain is 2.69 dBi < 6 dBi, so the output power limit shall not be reduced.

7.2 AC Power Conducted Emissions

RF Mode	802.11a	Channel	CH 157 : 5785 MHz
Frequency Range	150 kHz ~ 30 MHz	Detector Function & Resolution Bandwidth	Quasi-Peak (QP) / Average (AV), 9 kHz
Input Power	120 Vac, 60 Hz	Environmental Conditions	25°C, 75% RH
Tested By	Edison Lee		

Phase Of Power : Line (L)										
No	Frequency (MHz)	Correction Factor (dB)	Reading Value (dBuV)		Emission Level (dBuV)		Limit (dBuV)		Margin (dB)	
			Q.P.	AV.	Q.P.	AV.	Q.P.	AV.	Q.P.	AV.
1	0.15000	9.62	37.85	24.33	47.47	33.95	66.00	56.00	-18.53	-22.05
2	0.16600	9.63	35.48	19.91	45.11	29.54	65.16	55.16	-20.05	-25.62
3	0.40180	9.67	35.67	29.74	45.34	39.41	57.82	47.82	-12.48	-8.41
4	1.44198	9.70	13.57	7.84	23.27	17.54	56.00	46.00	-32.73	-28.46
5	7.83800	9.77	15.93	8.47	25.70	18.24	60.00	50.00	-34.30	-31.76
6	26.68600	9.74	7.69	1.52	17.43	11.26	60.00	50.00	-42.57	-38.74

Remarks:

1. Q.P. and AV. are abbreviations of quasi-peak and average individually.
2. The emission levels of other frequencies were very low against the limit.
3. Margin value = Emission level – Limit value
4. Correction factor = Insertion loss + Cable loss
5. Emission Level = Correction Factor + Reading Value

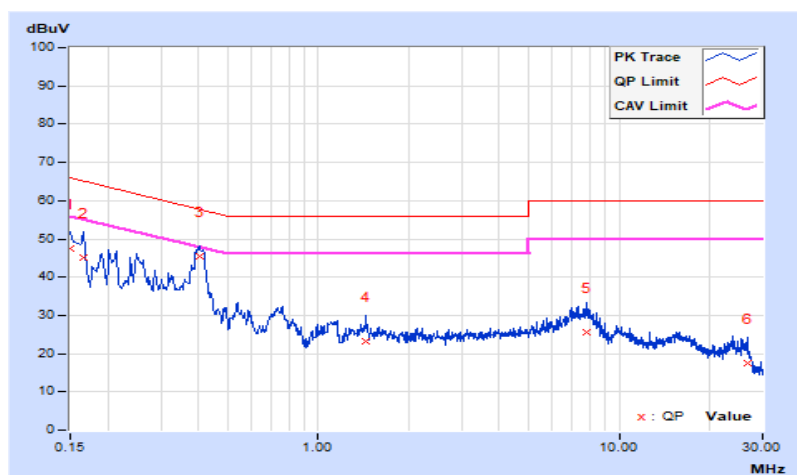

RF Mode	802.11a	Channel	CH 157 : 5785 MHz
Frequency Range	150 kHz ~ 30 MHz	Detector Function & Resolution Bandwidth	Quasi-Peak (QP) / Average (AV), 9 kHz
Input Power	120 Vac, 60 Hz	Environmental Conditions	25°C, 75% RH
Tested By	Edison Lee		

Phase Of Power : Neutral (N)										
No	Frequency (MHz)	Correction Factor (dB)	Reading Value (dBuV)		Emission Level (dBuV)		Limit (dBuV)		Margin (dB)	
			Q.P.	AV.	Q.P.	AV.	Q.P.	AV.	Q.P.	AV.
1	0.15400	9.62	37.24	19.66	46.86	29.28	65.78	55.78	-18.92	-26.50
2	0.18180	9.63	34.77	18.53	44.40	28.16	64.40	54.40	-20.00	-26.24
3	0.39400	9.67	25.74	18.40	35.41	28.07	57.98	47.98	-22.57	-19.91
4	1.43400	9.71	11.07	2.95	20.78	12.66	56.00	46.00	-35.22	-33.34
5	7.12600	9.78	11.97	3.95	21.75	13.73	60.00	50.00	-38.25	-36.27
6	23.12600	9.88	7.16	1.04	17.04	10.92	60.00	50.00	-42.96	-39.08

Remarks:

1. Q.P. and AV. are abbreviations of quasi-peak and average individually.
2. The emission levels of other frequencies were very low against the limit.
3. Margin value = Emission level – Limit value
4. Correction factor = Insertion loss + Cable loss
5. Emission Level = Correction Factor + Reading Value

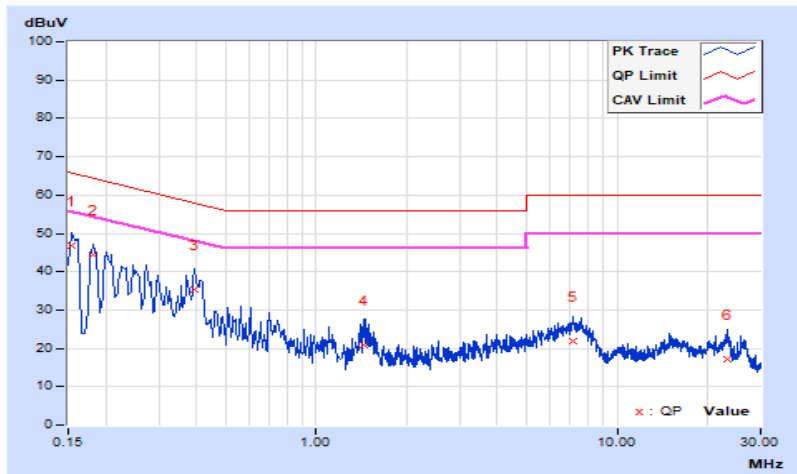

7.3 Unwanted Emissions below 1 GHz

RF Mode	802.11a	Channel	CH 157 : 5785 MHz
Frequency Range	30 MHz ~ 1 GHz	Detector Function & Bandwidth	QP: RB=120kHz, DET=Quasi-Peak
Input Power	120 Vac, 60 Hz	Environmental Conditions	25°C, 60% RH
Tested By	Karl Lee		

Antenna Polarity & Test Distance : Horizontal at 3 m								
No	Frequency (MHz)	Emission Level (dBuV/m)	Limit (dBuV/m)	Margin (dB)	Antenna Height (m)	Table Angle (Degree)	Raw Value (dBuV)	Correction Factor (dB/m)
1	91.79	30.5 QP	43.5	-13.0	1.72 H	44	33.3	-2.8
2	182.46	31.4 QP	43.5	-12.1	1.81 H	127	34.2	-2.8
3	206.15	25.7 QP	43.5	-17.8	1.92 H	226	28.5	-2.8
4	526.10	25.9 QP	46.0	-20.1	1.08 H	134	28.7	-2.8
5	720.41	23.7 QP	46.0	-22.3	2.16 H	149	26.5	-2.8
6	783.04	22.9 QP	46.0	-23.1	1.08 H	198	25.7	-2.8

Remarks:

1. Emission Level(dBuV/m) = Raw Value(dBuV) + Correction Factor(dB/m)
2. Correction Factor(dB/m) = Antenna Factor(dB/m) + Cable Factor(dB) – Pre-Amplifier Factor(dB)
3. Margin value = Emission Level – Limit value
4. The other emission levels were very low against the limit of frequency range 30 MHz ~ 1 GHz.
5. The frequency range 9 kHz ~ 30 MHz: all emissions are more than 20 dB below the limit, therefore do not be recorded in this report.

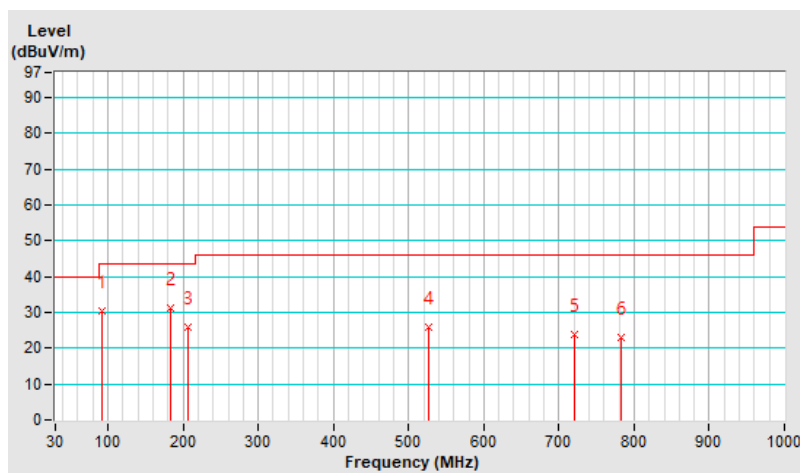

RF Mode	802.11a	Channel	CH 157 : 5785 MHz
Frequency Range	30 MHz ~ 1 GHz	Detector Function & Bandwidth	QP: RB=120kHz, DET=Quasi-Peak
Input Power	120 Vac, 60 Hz	Environmental Conditions	25°C, 60% RH
Tested By	Karl Lee		

Antenna Polarity & Test Distance : Vertical at 3 m								
No	Frequency (MHz)	Emission Level (dBuV/m)	Limit (dBuV/m)	Margin (dB)	Antenna Height (m)	Table Angle (Degree)	Raw Value (dBuV)	Correction Factor (dB/m)
1	83.75	31.4 QP	40.0	-8.6	1.76 V	352	34.2	-2.8
2	106.06	32.7 QP	43.5	-10.8	1.93 V	77	35.5	-2.8
3	184.55	26.3 QP	43.5	-17.2	1.14 V	206	29.1	-2.8
4	495.78	22.7 QP	46.0	-23.3	1.49 V	210	25.5	-2.8
5	674.59	20.5 QP	46.0	-25.5	1.84 V	232	23.3	-2.8
6	821.17	23.0 QP	46.0	-23.0	2.17 V	141	25.8	-2.8

Remarks:

1. Emission Level(dBuV/m) = Raw Value(dBuV) + Correction Factor(dB/m)
2. Correction Factor(dB/m) = Antenna Factor(dB/m) + Cable Factor(dB) – Pre-Amplifier Factor(dB)
3. Margin value = Emission Level – Limit value
4. The other emission levels were very low against the limit of frequency range 30 MHz ~ 1 GHz.
5. The frequency range 9 kHz ~ 30 MHz: all emissions are more than 20 dB below the limit, therefore do not be recorded in this report.

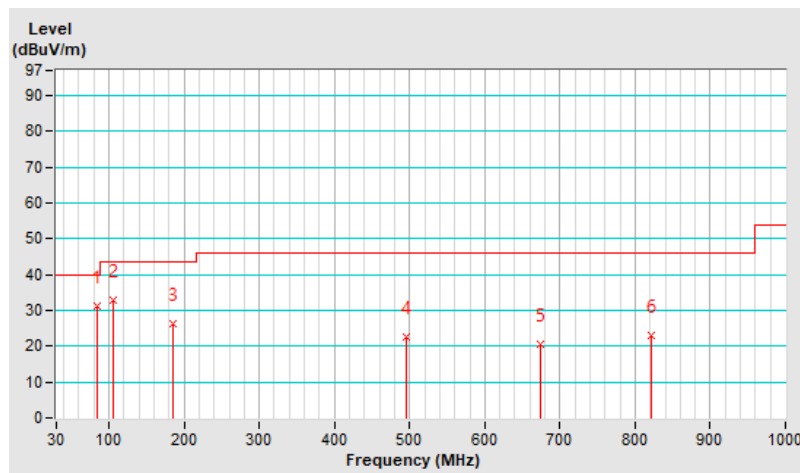

7.4 Unwanted Emissions above 1 GHz

RF Mode	802.11a	Channel	CH 36 : 5180 MHz
Frequency Range	1 GHz ~ 40 GHz	Detector Function & Bandwidth	PK: RB=1 MHz, VB=3 MHz, DET=Peak AV: RB=1 MHz, VB=10 Hz, DET=Peak
Input Power	120 Vac, 60 Hz	Environmental Conditions	25°C, 60% RH
Tested By	Karl Lee		

Antenna Polarity & Test Distance : Horizontal at 3 m								
No	Frequency (MHz)	Emission Level (dBuV/m)	Limit (dBuV/m)	Margin (dB)	Antenna Height (m)	Table Angle (Degree)	Raw Value (dBuV)	Correction Factor (dB/m)
1	5150.00	65.6 PK	74.0	-8.4	1.21 H	190	53.1	12.5
2	5150.00	52.4 AV	54.0	-1.6	1.21 H	190	39.9	12.5
3	*5180.00	108.6 PK			1.21 H	190	66.1	42.5
4	*5180.00	100.2 AV			1.21 H	190	57.7	42.5
5	#10360.00	57.1 PK	68.2	-11.1	2.22 H	108	38.6	18.5
Antenna Polarity & Test Distance : Vertical at 3 m								
No	Frequency (MHz)	Emission Level (dBuV/m)	Limit (dBuV/m)	Margin (dB)	Antenna Height (m)	Table Angle (Degree)	Raw Value (dBuV)	Correction Factor (dB/m)
1	5150.00	59.2 PK	74.0	-14.8	1.47 V	274	46.7	12.5
2	5150.00	49.9 AV	54.0	-4.1	1.47 V	274	37.4	12.5
3	*5180.00	105.0 PK			1.47 V	274	62.5	42.5
4	*5180.00	97.0 AV			1.47 V	274	54.5	42.5
5	#10360.00	56.9 PK	68.2	-11.3	1.75 V	263	38.4	18.5

Remarks:

1. Emission Level(dBuV/m) = Raw Value(dBuV) + Correction Factor(dB/m)
2. Correction Factor(dB/m) = Antenna Factor(dB/m) + Cable Factor(dB) – Pre-Amplifier Factor(dB)
3. Margin value = Emission Level – Limit value
4. The other emission levels were very low against the limit.
5. " * ": Fundamental frequency, the limit was restricted at the RF Output Power.
6. " # ": The radiated frequency is out of the restricted band.



RF Mode	802.11a	Channel	CH 40 : 5200 MHz
Frequency Range	1 GHz ~ 40 GHz	Detector Function & Bandwidth	PK: RB=1 MHz, VB=3 MHz, DET=Peak AV: RB=1 MHz, VB=10 Hz, DET=Peak
Input Power	120 Vac, 60 Hz	Environmental Conditions	25°C, 60% RH
Tested By	Karl Lee		

Antenna Polarity & Test Distance : Horizontal at 3 m								
No	Frequency (MHz)	Emission Level (dBuV/m)	Limit (dBuV/m)	Margin (dB)	Antenna Height (m)	Table Angle (Degree)	Raw Value (dBuV)	Correction Factor (dB/m)
1	*5200.00	108.8 PK			1.23 H	197	66.3	42.5
2	*5200.00	100.3 AV			1.23 H	197	57.8	42.5
3	#10400.00	56.8 PK	68.2	-11.4	1.93 H	23	38.3	18.5
Antenna Polarity & Test Distance : Vertical at 3 m								
No	Frequency (MHz)	Emission Level (dBuV/m)	Limit (dBuV/m)	Margin (dB)	Antenna Height (m)	Table Angle (Degree)	Raw Value (dBuV)	Correction Factor (dB/m)
1	*5200.00	105.3 PK			1.52 V	271	62.8	42.5
2	*5200.00	100.1 AV			1.52 V	271	57.6	42.5
3	#10400.00	56.4 PK	68.2	-11.8	1.28 V	254	37.9	18.5

Remarks:

1. Emission Level(dBuV/m) = Raw Value(dBuV) + Correction Factor(dB/m)
2. Correction Factor(dB/m) = Antenna Factor(dB/m) + Cable Factor(dB) – Pre-Amplifier Factor(dB)
3. Margin value = Emission Level – Limit value
4. The other emission levels were very low against the limit.
5. " * ": Fundamental frequency, the limit was restricted at the RF Output Power.
6. " # ": The radiated frequency is out of the restricted band.



RF Mode	802.11a	Channel	CH 48 : 5240 MHz
Frequency Range	1 GHz ~ 40 GHz	Detector Function & Bandwidth	PK: RB=1 MHz, VB=3 MHz, DET=Peak AV: RB=1 MHz, VB=10 Hz, DET=Peak
Input Power	120 Vac, 60 Hz	Environmental Conditions	25°C, 60% RH
Tested By	Karl Lee		

Antenna Polarity & Test Distance : Horizontal at 3 m

No	Frequency (MHz)	Emission Level (dBuV/m)	Limit (dBuV/m)	Margin (dB)	Antenna Height (m)	Table Angle (Degree)	Raw Value (dBuV)	Correction Factor (dB/m)
1	*5240.00	108.4 PK			1.15 H	191	65.7	42.7
2	*5240.00	100.4 AV			1.15 H	191	57.7	42.7
3	5350.00	57.0 PK	74.0	-17.0	1.15 H	191	44.1	12.9
4	5350.00	46.5 AV	54.0	-7.5	1.15 H	191	33.6	12.9
5	#10480.00	57.0 PK	68.2	-11.2	2.81 H	108	38.7	18.3

Antenna Polarity & Test Distance : Vertical at 3 m

No	Frequency (MHz)	Emission Level (dBuV/m)	Limit (dBuV/m)	Margin (dB)	Antenna Height (m)	Table Angle (Degree)	Raw Value (dBuV)	Correction Factor (dB/m)
1	*5240.00	105.2 PK			1.54 V	268	62.5	42.7
2	*5240.00	97.2 AV			1.54 V	268	54.5	42.7
3	5350.00	56.7 PK	74.0	-17.3	1.54 V	268	43.8	12.9
4	5350.00	46.5 AV	54.0	-7.5	1.54 V	268	33.6	12.9
5	#10480.00	56.5 PK	68.2	-11.7	2.11 V	191	38.2	18.3

Remarks:

1. Emission Level(dBuV/m) = Raw Value(dBuV) + Correction Factor(dB/m)
2. Correction Factor(dB/m) = Antenna Factor(dB/m) + Cable Factor(dB) – Pre-Amplifier Factor(dB)
3. Margin value = Emission Level – Limit value
4. The other emission levels were very low against the limit.
5. " * " : Fundamental frequency, the limit was restricted at the RF Output Power.
6. " # " : The radiated frequency is out of the restricted band.



RF Mode	802.11n (HT20)	Channel	CH 36 : 5180 MHz
Frequency Range	1 GHz ~ 40 GHz	Detector Function & Bandwidth	PK: RB=1 MHz, VB=3 MHz, DET=Peak AV: RB=1 MHz, VB=10 Hz, DET=Peak
Input Power	120 Vac, 60 Hz	Environmental Conditions	25°C, 60% RH
Tested By	Karl Lee		

Antenna Polarity & Test Distance : Horizontal at 3 m								
No	Frequency (MHz)	Emission Level (dBuV/m)	Limit (dBuV/m)	Margin (dB)	Antenna Height (m)	Table Angle (Degree)	Raw Value (dBuV)	Correction Factor (dB/m)
1	5150.00	64.5 PK	74.0	-9.5	1.21 H	190	52.0	12.5
2	5150.00	52.2 AV	54.0	-1.8	1.21 H	190	39.7	12.5
3	*5180.00	107.3 PK			1.21 H	190	64.8	42.5
4	*5180.00	99.5 AV			1.21 H	190	57.0	42.5
5	#10360.00	57.1 PK	68.2	-11.1	1.34 H	71	38.6	18.5

Antenna Polarity & Test Distance : Vertical at 3 m								
No	Frequency (MHz)	Emission Level (dBuV/m)	Limit (dBuV/m)	Margin (dB)	Antenna Height (m)	Table Angle (Degree)	Raw Value (dBuV)	Correction Factor (dB/m)
1	5150.00	61.6 PK	74.0	-12.4	1.47 V	274	49.1	12.5
2	5150.00	50.1 AV	54.0	-3.9	1.47 V	274	37.6	12.5
3	*5180.00	104.0 PK			1.47 V	274	61.5	42.5
4	*5180.00	96.3 AV			1.47 V	274	53.8	42.5
5	#10360.00	56.3 PK	68.2	-11.9	1.69 V	244	37.8	18.5

Remarks:

1. Emission Level(dBuV/m) = Raw Value(dBuV) + Correction Factor(dB/m)
2. Correction Factor(dB/m) = Antenna Factor(dB/m) + Cable Factor(dB) – Pre-Amplifier Factor(dB)
3. Margin value = Emission Level – Limit value
4. The other emission levels were very low against the limit.
5. " * ": Fundamental frequency, the limit was restricted at the RF Output Power.
6. " # ": The radiated frequency is out of the restricted band.



RF Mode	802.11n (HT20)	Channel	CH 40 : 5200 MHz
Frequency Range	1 GHz ~ 40 GHz	Detector Function & Bandwidth	PK: RB=1 MHz, VB=3 MHz, DET=Peak AV: RB=1 MHz, VB=10 Hz, DET=Peak
Input Power	120 Vac, 60 Hz	Environmental Conditions	25°C, 60% RH
Tested By	Karl Lee		

Antenna Polarity & Test Distance : Horizontal at 3 m								
No	Frequency (MHz)	Emission Level (dBuV/m)	Limit (dBuV/m)	Margin (dB)	Antenna Height (m)	Table Angle (Degree)	Raw Value (dBuV)	Correction Factor (dB/m)
1	*5200.00	107.9 PK			1.23 H	197	65.4	42.5
2	*5200.00	100.0 AV			1.23 H	197	57.5	42.5
3	#10400.00	56.6 PK	68.2	-11.6	2.53 H	189	38.1	18.5
Antenna Polarity & Test Distance : Vertical at 3 m								
No	Frequency (MHz)	Emission Level (dBuV/m)	Limit (dBuV/m)	Margin (dB)	Antenna Height (m)	Table Angle (Degree)	Raw Value (dBuV)	Correction Factor (dB/m)
1	*5200.00	104.6 PK			1.52 V	271	62.1	42.5
2	*5200.00	97.0 AV			1.52 V	271	54.5	42.5
3	#10400.00	56.8 PK	68.2	-11.4	1.63 V	259	38.3	18.5

Remarks:

1. Emission Level(dBuV/m) = Raw Value(dBuV) + Correction Factor(dB/m)
2. Correction Factor(dB/m) = Antenna Factor(dB/m) + Cable Factor(dB) – Pre-Amplifier Factor(dB)
3. Margin value = Emission Level – Limit value
4. The other emission levels were very low against the limit.
5. " * ": Fundamental frequency, the limit was restricted at the RF Output Power.
6. " # ": The radiated frequency is out of the restricted band.



RF Mode	802.11n (HT20)	Channel	CH 48 : 5240 MHz
Frequency Range	1 GHz ~ 40 GHz	Detector Function & Bandwidth	PK: RB=1 MHz, VB=3 MHz, DET=Peak AV: RB=1 MHz, VB=10 Hz, DET=Peak
Input Power	120 Vac, 60 Hz	Environmental Conditions	25°C, 60% RH
Tested By	Karl Lee		

Antenna Polarity & Test Distance : Horizontal at 3 m								
No	Frequency (MHz)	Emission Level (dBuV/m)	Limit (dBuV/m)	Margin (dB)	Antenna Height (m)	Table Angle (Degree)	Raw Value (dBuV)	Correction Factor (dB/m)
1	*5240.00	108.5 PK			1.15 H	191	65.8	42.7
2	*5240.00	100.2 AV			1.15 H	191	57.5	42.7
3	5350.00	56.9 PK	74.0	-17.1	1.15 H	191	44.0	12.9
4	5350.00	46.5 AV	54.0	-7.5	1.15 H	191	33.6	12.9
5	#10480.00	56.1 PK	68.2	-12.1	2.25 H	137	37.8	18.3

Antenna Polarity & Test Distance : Vertical at 3 m								
No	Frequency (MHz)	Emission Level (dBuV/m)	Limit (dBuV/m)	Margin (dB)	Antenna Height (m)	Table Angle (Degree)	Raw Value (dBuV)	Correction Factor (dB/m)
1	*5240.00	104.5 PK			1.54 V	268	61.8	42.7
2	*5240.00	96.9 AV			1.54 V	268	54.2	42.7
3	5350.00	56.5 PK	74.0	-17.5	1.54 V	268	43.6	12.9
4	5350.00	46.5 AV	54.0	-7.5	1.54 V	268	33.6	12.9
5	#10480.00	56.9 PK	68.2	-11.3	2.24 V	105	38.6	18.3

Remarks:

1. Emission Level(dBuV/m) = Raw Value(dBuV) + Correction Factor(dB/m)
2. Correction Factor(dB/m) = Antenna Factor(dB/m) + Cable Factor(dB) – Pre-Amplifier Factor(dB)
3. Margin value = Emission Level – Limit value
4. The other emission levels were very low against the limit.
5. " * ": Fundamental frequency, the limit was restricted at the RF Output Power.
6. " # ": The radiated frequency is out of the restricted band.



RF Mode	802.11n (HT40)	Channel	CH 38 : 5190 MHz
Frequency Range	1 GHz ~ 40 GHz	Detector Function & Bandwidth	PK: RB=1 MHz, VB=3 MHz, DET=Peak AV: RB=1 MHz, VB=10 Hz, DET=Peak
Input Power	120 Vac, 60 Hz	Environmental Conditions	25°C, 60% RH
Tested By	Karl Lee		

Antenna Polarity & Test Distance : Horizontal at 3 m

No	Frequency (MHz)	Emission Level (dBuV/m)	Limit (dBuV/m)	Margin (dB)	Antenna Height (m)	Table Angle (Degree)	Raw Value (dBuV)	Correction Factor (dB/m)
1	5150.00	64.0 PK	74.0	-10.0	1.25 H	192	51.5	12.5
2	5150.00	53.0 AV	54.0	-1.0	1.25 H	192	40.5	12.5
3	*5190.00	102.1 PK			1.25 H	192	59.6	42.5
4	*5190.00	94.0 AV			1.25 H	192	51.5	42.5
5	5350.00	57.5 PK	74.0	-16.5	1.25 H	192	44.6	12.9
6	5350.00	46.3 AV	54.0	-7.7	1.25 H	192	33.4	12.9
7	#10380.00	56.3 PK	68.2	-11.9	2.53 H	228	37.9	18.4

Antenna Polarity & Test Distance : Vertical at 3 m

No	Frequency (MHz)	Emission Level (dBuV/m)	Limit (dBuV/m)	Margin (dB)	Antenna Height (m)	Table Angle (Degree)	Raw Value (dBuV)	Correction Factor (dB/m)
1	5150.00	60.9 PK	74.0	-13.1	1.42 V	277	48.4	12.5
2	5150.00	50.9 AV	54.0	-3.1	1.42 V	277	38.4	12.5
3	*5190.00	98.2 PK			1.42 V	277	55.7	42.5
4	*5190.00	90.3 AV			1.42 V	277	47.8	42.5
5	5350.00	56.3 PK	74.0	-17.7	1.42 V	277	43.4	12.9
6	5350.00	46.4 AV	54.0	-7.6	1.42 V	277	33.5	12.9
7	#10380.00	55.9 PK	68.2	-12.3	1.23 V	182	37.5	18.4

Remarks:

1. Emission Level(dBuV/m) = Raw Value(dBuV) + Correction Factor(dB/m)
2. Correction Factor(dB/m) = Antenna Factor(dB/m) + Cable Factor(dB) – Pre-Amplifier Factor(dB)
3. Margin value = Emission Level – Limit value
4. The other emission levels were very low against the limit.
5. " * " : Fundamental frequency, the limit was restricted at the RF Output Power.
6. " # " : The radiated frequency is out of the restricted band.



RF Mode	802.11n (HT40)	Channel	CH 46 : 5230 MHz
Frequency Range	1 GHz ~ 40 GHz	Detector Function & Bandwidth	PK: RB=1 MHz, VB=3 MHz, DET=Peak AV: RB=1 MHz, VB=10 Hz, DET=Peak
Input Power	120 Vac, 60 Hz	Environmental Conditions	25°C, 60% RH
Tested By	Karl Lee		

Antenna Polarity & Test Distance : Horizontal at 3 m

No	Frequency (MHz)	Emission Level (dBuV/m)	Limit (dBuV/m)	Margin (dB)	Antenna Height (m)	Table Angle (Degree)	Raw Value (dBuV)	Correction Factor (dB/m)
1	5150.00	57.0 PK	74.0	-17.0	1.20 H	191	44.5	12.5
2	5150.00	47.4 AV	54.0	-6.6	1.20 H	191	34.9	12.5
3	*5230.00	105.6 PK			1.20 H	191	63.0	42.6
4	*5230.00	97.2 AV			1.20 H	191	54.6	42.6
5	5350.00	56.3 PK	74.0	-17.7	1.20 H	191	43.4	12.9
6	5350.00	46.5 AV	54.0	-7.5	1.20 H	191	33.6	12.9
7	#10460.00	56.0 PK	68.2	-12.2	2.11 H	63	37.7	18.3

Antenna Polarity & Test Distance : Vertical at 3 m

No	Frequency (MHz)	Emission Level (dBuV/m)	Limit (dBuV/m)	Margin (dB)	Antenna Height (m)	Table Angle (Degree)	Raw Value (dBuV)	Correction Factor (dB/m)
1	5150.00	56.8 PK	74.0	-17.2	1.49 V	266	44.3	12.5
2	5150.00	46.7 AV	54.0	-7.3	1.49 V	266	34.2	12.5
3	*5230.00	101.3 PK			1.49 V	266	58.7	42.6
4	*5230.00	93.5 AV			1.49 V	266	50.9	42.6
5	5350.00	57.0 PK	74.0	-17.0	1.49 V	266	44.1	12.9
6	5350.00	46.6 AV	54.0	-7.4	1.49 V	266	33.7	12.9
7	#10460.00	56.4 PK	68.2	-11.8	2.13 V	106	38.1	18.3

Remarks:

1. Emission Level(dBuV/m) = Raw Value(dBuV) + Correction Factor(dB/m)
2. Correction Factor(dB/m) = Antenna Factor(dB/m) + Cable Factor(dB) – Pre-Amplifier Factor(dB)
3. Margin value = Emission Level – Limit value
4. The other emission levels were very low against the limit.
5. " * " : Fundamental frequency, the limit was restricted at the RF Output Power.
6. " # " : The radiated frequency is out of the restricted band.



RF Mode	802.11a	Channel	CH 149 : 5745 MHz
Frequency Range	1 GHz ~ 40 GHz	Detector Function & Bandwidth	PK: RB=1 MHz, VB=3 MHz, DET=Peak AV: RB=1 MHz, VB=10 Hz, DET=Peak
Input Power	120 Vac, 60 Hz	Environmental Conditions	25°C, 60% RH
Tested By	Charles Hsiao		

Antenna Polarity & Test Distance : Horizontal at 3 m

No	Frequency (MHz)	Emission Level (dBuV/m)	Limit (dBuV/m)	Margin (dB)	Antenna Height (m)	Table Angle (Degree)	Raw Value (dBuV)	Correction Factor (dB/m)
1	#5626.03	56.1 PK	68.2	-12.1	1.46 H	68	43.2	12.9
2	*5745.00	108.4 PK			1.46 H	68	65.0	43.4
3	*5745.00	99.6 AV			1.46 H	68	56.2	43.4
4	#5950.75	56.7 PK	68.2	-11.5	1.46 H	68	42.8	13.9
5	11490.00	57.4 PK	74.0	-16.6	1.16 H	345	37.5	19.9
6	11490.00	48.3 AV	54.0	-5.7	1.16 H	345	28.4	19.9

Antenna Polarity & Test Distance : Vertical at 3 m

No	Frequency (MHz)	Emission Level (dBuV/m)	Limit (dBuV/m)	Margin (dB)	Antenna Height (m)	Table Angle (Degree)	Raw Value (dBuV)	Correction Factor (dB/m)
1	#5646.85	55.5 PK	68.2	-12.7	1.09 V	186	42.4	13.1
2	*5745.00	105.3 PK			1.09 V	186	61.9	43.4
3	*5745.00	96.6 AV			1.09 V	186	53.2	43.4
4	#5933.53	55.8 PK	68.2	-12.4	1.09 V	186	42.0	13.8
5	11490.00	57.2 PK	74.0	-16.8	1.75 V	214	37.3	19.9
6	11490.00	48.0 AV	54.0	-6.0	1.75 V	214	28.1	19.9

Remarks:

1. Emission Level(dBuV/m) = Raw Value(dBuV) + Correction Factor(dB/m)
2. Correction Factor(dB/m) = Antenna Factor(dB/m) + Cable Factor(dB) – Pre-Amplifier Factor(dB)
3. Margin value = Emission Level – Limit value
4. The other emission levels were very low against the limit.
5. " * " : Fundamental frequency, the limit was restricted at the RF Output Power.



RF Mode	802.11a	Channel	CH 157 : 5785 MHz
Frequency Range	1 GHz ~ 40 GHz	Detector Function & Bandwidth	PK: RB=1 MHz, VB=3 MHz, DET=Peak AV: RB=1 MHz, VB=10 Hz, DET=Peak
Input Power	120 Vac, 60 Hz	Environmental Conditions	25°C, 60% RH
Tested By	Charles Hsiao		

Antenna Polarity & Test Distance : Horizontal at 3 m

No	Frequency (MHz)	Emission Level (dBuV/m)	Limit (dBuV/m)	Margin (dB)	Antenna Height (m)	Table Angle (Degree)	Raw Value (dBuV)	Correction Factor (dB/m)
1	#5646.05	56.6 PK	68.2	-11.6	1.46 H	68	43.5	13.1
2	*5785.00	108.0 PK			1.46 H	68	64.6	43.4
3	*5785.00	99.1 AV			1.46 H	68	55.7	43.4
4	#5929.93	56.4 PK	68.2	-11.8	1.46 H	68	42.6	13.8
5	11570.00	57.4 PK	74.0	-16.6	1.69 H	99	37.5	19.9
6	11570.00	48.3 AV	54.0	-5.7	1.69 H	99	28.4	19.9

Antenna Polarity & Test Distance : Vertical at 3 m

No	Frequency (MHz)	Emission Level (dBuV/m)	Limit (dBuV/m)	Margin (dB)	Antenna Height (m)	Table Angle (Degree)	Raw Value (dBuV)	Correction Factor (dB/m)
1	#5635.64	55.2 PK	68.2	-13.0	1.09 V	186	42.3	12.9
2	*5785.00	105.0 PK			1.09 V	186	61.6	43.4
3	*5785.00	96.2 AV			1.09 V	186	52.8	43.4
4	#5960.36	56.0 PK	68.2	-12.2	1.09 V	186	42.1	13.9
5	11570.00	57.3 PK	74.0	-16.7	1.75 V	3	37.4	19.9
6	11570.00	48.2 AV	54.0	-5.8	1.75 V	3	28.3	19.9

Remarks:

1. Emission Level(dBuV/m) = Raw Value(dBuV) + Correction Factor(dB/m)
2. Correction Factor(dB/m) = Antenna Factor(dB/m) + Cable Factor(dB) – Pre-Amplifier Factor(dB)
3. Margin value = Emission Level – Limit value
4. The other emission levels were very low against the limit.
5. " * " : Fundamental frequency, the limit was restricted at the RF Output Power.
6. " # " : The radiated frequency is out of the restricted band.



RF Mode	802.11a	Channel	CH 165 : 5825 MHz
Frequency Range	1 GHz ~ 40 GHz	Detector Function & Bandwidth	PK: RB=1 MHz, VB=3 MHz, DET=Peak AV: RB=1 MHz, VB=10 Hz, DET=Peak
Input Power	120 Vac, 60 Hz	Environmental Conditions	25°C, 60% RH
Tested By	Charles Hsiao		

Antenna Polarity & Test Distance : Horizontal at 3 m

No	Frequency (MHz)	Emission Level (dBuV/m)	Limit (dBuV/m)	Margin (dB)	Antenna Height (m)	Table Angle (Degree)	Raw Value (dBuV)	Correction Factor (dB/m)
1	#5638.44	55.5 PK	68.2	-12.7	1.46 H	53	42.6	12.9
2	*5825.00	107.1 PK			1.46 H	53	63.6	43.5
3	*5825.00	98.8 AV			1.46 H	53	55.3	43.5
4	#5977.98	55.9 PK	68.2	-12.3	1.46 H	53	41.9	14.0
5	11650.00	57.2 PK	74.0	-16.8	1.17 H	48	37.3	19.9
6	11650.00	48.1 AV	54.0	-5.9	1.17 H	48	28.2	19.9

Antenna Polarity & Test Distance : Vertical at 3 m

No	Frequency (MHz)	Emission Level (dBuV/m)	Limit (dBuV/m)	Margin (dB)	Antenna Height (m)	Table Angle (Degree)	Raw Value (dBuV)	Correction Factor (dB/m)
1	#5606.41	55.7 PK	68.2	-12.5	1.09 V	190	42.7	13.0
2	*5825.00	104.2 PK			1.09 V	190	60.7	43.5
3	*5825.00	95.4 AV			1.09 V	190	51.9	43.5
4	#5978.78	56.0 PK	68.2	-12.2	1.09 V	190	42.0	14.0
5	11650.00	57.1 PK	74.0	-16.9	1.15 V	57	37.2	19.9
6	11650.00	48.0 AV	54.0	-6.0	1.15 V	57	28.1	19.9

Remarks:

1. Emission Level(dBuV/m) = Raw Value(dBuV) + Correction Factor(dB/m)
2. Correction Factor(dB/m) = Antenna Factor(dB/m) + Cable Factor(dB) – Pre-Amplifier Factor(dB)
3. Margin value = Emission Level – Limit value
4. The other emission levels were very low against the limit.
5. " * ": Fundamental frequency, the limit was restricted at the RF Output Power.
6. " # ": The radiated frequency is out of the restricted band.



RF Mode	802.11n (HT20)	Channel	CH 149 : 5745 MHz
Frequency Range	1 GHz ~ 40 GHz	Detector Function & Bandwidth	PK: RB=1 MHz, VB=3 MHz, DET=Peak AV: RB=1 MHz, VB=10 Hz, DET=Peak
Input Power	120 Vac, 60 Hz	Environmental Conditions	25°C, 60% RH
Tested By	Charles Hsiao		

Antenna Polarity & Test Distance : Horizontal at 3 m

No	Frequency (MHz)	Emission Level (dBuV/m)	Limit (dBuV/m)	Margin (dB)	Antenna Height (m)	Table Angle (Degree)	Raw Value (dBuV)	Correction Factor (dB/m)
1	#5648.05	55.2 PK	68.2	-13.0	1.46 H	68	42.1	13.1
2	*5745.00	107.8 PK			1.46 H	68	64.4	43.4
3	*5745.00	98.7 AV			1.46 H	68	55.3	43.4
4	#5978.78	56.1 PK	68.2	-12.1	1.46 H	68	42.1	14.0
5	11490.00	57.6 PK	74.0	-16.4	1.15 H	190	37.7	19.9
6	11490.00	48.3 AV	54.0	-5.7	1.15 H	190	28.4	19.9

Antenna Polarity & Test Distance : Vertical at 3 m

No	Frequency (MHz)	Emission Level (dBuV/m)	Limit (dBuV/m)	Margin (dB)	Antenna Height (m)	Table Angle (Degree)	Raw Value (dBuV)	Correction Factor (dB/m)
1	#5623.62	55.1 PK	68.2	-13.1	1.09 V	186	42.2	12.9
2	*5745.00	104.6 PK			1.09 V	186	61.2	43.4
3	*5745.00	95.5 AV			1.09 V	186	52.1	43.4
4	#5978.78	56.0 PK	68.2	-12.2	1.09 V	186	42.0	14.0
5	11490.00	57.4 PK	74.0	-16.6	1.57 V	250	37.5	19.9
6	11490.00	48.1 AV	54.0	-5.9	1.57 V	250	28.2	19.9

Remarks:

1. Emission Level(dBuV/m) = Raw Value(dBuV) + Correction Factor(dB/m)
2. Correction Factor(dB/m) = Antenna Factor(dB/m) + Cable Factor(dB) – Pre-Amplifier Factor(dB)
3. Margin value = Emission Level – Limit value
4. The other emission levels were very low against the limit.
5. " * " : Fundamental frequency, the limit was restricted at the RF Output Power.
6. " # " : The radiated frequency is out of the restricted band.



RF Mode	802.11n (HT20)	Channel	CH 157 : 5785 MHz
Frequency Range	1 GHz ~ 40 GHz	Detector Function & Bandwidth	PK: RB=1 MHz, VB=3 MHz, DET=Peak AV: RB=1 MHz, VB=10 Hz, DET=Peak
Input Power	120 Vac, 60 Hz	Environmental Conditions	25°C, 60% RH
Tested By	Charles Hsiao		

Antenna Polarity & Test Distance : Horizontal at 3 m

No	Frequency (MHz)	Emission Level (dBuV/m)	Limit (dBuV/m)	Margin (dB)	Antenna Height (m)	Table Angle (Degree)	Raw Value (dBuV)	Correction Factor (dB/m)
1	#5640.04	55.7 PK	68.2	-12.5	1.46 H	68	42.8	12.9
2	*5785.00	108.2 PK			1.46 H	68	64.8	43.4
3	*5785.00	99.7 AV			1.46 H	68	56.3	43.4
4	#5978.38	56.1 PK	68.2	-12.1	1.46 H	68	42.1	14.0
5	11570.00	57.2 PK	74.0	-16.8	1.16 H	65	37.3	19.9
6	11570.00	48.3 AV	54.0	-5.7	1.16 H	65	28.4	19.9

Antenna Polarity & Test Distance : Vertical at 3 m

No	Frequency (MHz)	Emission Level (dBuV/m)	Limit (dBuV/m)	Margin (dB)	Antenna Height (m)	Table Angle (Degree)	Raw Value (dBuV)	Correction Factor (dB/m)
1	#5634.83	55.7 PK	68.2	-12.5	1.09 V	186	42.8	12.9
2	*5785.00	105.1 PK			1.09 V	186	61.7	43.4
3	*5785.00	96.4 AV			1.09 V	186	53.0	43.4
4	#5943.94	55.7 PK	68.2	-12.5	1.09 V	186	41.8	13.9
5	11570.00	57.2 PK	74.0	-16.8	1.65 V	331	37.3	19.9
6	11570.00	47.9 AV	54.0	-6.1	1.65 V	331	28.0	19.9

Remarks:

1. Emission Level(dBuV/m) = Raw Value(dBuV) + Correction Factor(dB/m)
2. Correction Factor(dB/m) = Antenna Factor(dB/m) + Cable Factor(dB) – Pre-Amplifier Factor(dB)
3. Margin value = Emission Level – Limit value
4. The other emission levels were very low against the limit.
5. " * " : Fundamental frequency, the limit was restricted at the RF Output Power.
6. " # " : The radiated frequency is out of the restricted band.



RF Mode	802.11n (HT20)	Channel	CH 165 : 5825 MHz
Frequency Range	1 GHz ~ 40 GHz	Detector Function & Bandwidth	PK: RB=1 MHz, VB=3 MHz, DET=Peak AV: RB=1 MHz, VB=10 Hz, DET=Peak
Input Power	120 Vac, 60 Hz	Environmental Conditions	25°C, 60% RH
Tested By	Charles Hsiao		

Antenna Polarity & Test Distance : Horizontal at 3 m

No	Frequency (MHz)	Emission Level (dBuV/m)	Limit (dBuV/m)	Margin (dB)	Antenna Height (m)	Table Angle (Degree)	Raw Value (dBuV)	Correction Factor (dB/m)
1	#5614.01	55.9 PK	68.2	-12.3	1.46 H	53	42.9	13.0
2	*5825.00	107.2 PK			1.46 H	53	63.7	43.5
3	*5825.00	98.3 AV			1.46 H	53	54.8	43.5
4	#5970.37	56.8 PK	68.2	-11.4	1.46 H	53	42.8	14.0
5	11650.00	57.5 PK	74.0	-16.5	1.75 H	225	37.6	19.9
6	11650.00	48.4 AV	54.0	-5.6	1.75 H	225	28.5	19.9

Antenna Polarity & Test Distance : Vertical at 3 m

No	Frequency (MHz)	Emission Level (dBuV/m)	Limit (dBuV/m)	Margin (dB)	Antenna Height (m)	Table Angle (Degree)	Raw Value (dBuV)	Correction Factor (dB/m)
1	#5648.45	54.8 PK	68.2	-13.4	1.09 V	190	41.7	13.1
2	*5825.00	104.1 PK			1.09 V	190	60.6	43.5
3	*5825.00	95.2 AV			1.09 V	190	51.7	43.5
4	#5969.17	56.4 PK	68.2	-11.8	1.09 V	190	42.4	14.0
5	11650.00	57.3 PK	74.0	-16.7	1.75 V	221	37.4	19.9
6	11650.00	48.2 AV	54.0	-5.8	1.75 V	221	28.3	19.9

Remarks:

1. Emission Level(dBuV/m) = Raw Value(dBuV) + Correction Factor(dB/m)
2. Correction Factor(dB/m) = Antenna Factor(dB/m) + Cable Factor(dB) – Pre-Amplifier Factor(dB)
3. Margin value = Emission Level – Limit value
4. The other emission levels were very low against the limit.
5. " * " : Fundamental frequency, the limit was restricted at the RF Output Power.
6. " # " : The radiated frequency is out of the restricted band.



RF Mode	802.11n (HT40)	Channel	CH 151 : 5755 MHz
Frequency Range	1 GHz ~ 40 GHz	Detector Function & Bandwidth	PK: RB=1 MHz, VB=3 MHz, DET=Peak AV: RB=1 MHz, VB=10 Hz, DET=Peak
Input Power	120 Vac, 60 Hz	Environmental Conditions	25°C, 60% RH
Tested By	Charles Hsiao		

Antenna Polarity & Test Distance : Horizontal at 3 m

No	Frequency (MHz)	Emission Level (dBuV/m)	Limit (dBuV/m)	Margin (dB)	Antenna Height (m)	Table Angle (Degree)	Raw Value (dBuV)	Correction Factor (dB/m)
1	#5649.65	57.9 PK	68.2	-10.3	1.46 H	68	44.8	13.1
2	*5755.00	104.9 PK			1.46 H	68	61.5	43.4
3	*5755.00	95.6 AV			1.46 H	68	52.2	43.4
4	#5975.98	56.1 PK	68.2	-12.1	1.46 H	68	42.1	14.0
5	11510.00	57.4 PK	74.0	-16.6	1.95 H	64	37.5	19.9
6	11510.00	48.3 AV	54.0	-5.7	1.95 H	64	28.4	19.9

Antenna Polarity & Test Distance : Vertical at 3 m

No	Frequency (MHz)	Emission Level (dBuV/m)	Limit (dBuV/m)	Margin (dB)	Antenna Height (m)	Table Angle (Degree)	Raw Value (dBuV)	Correction Factor (dB/m)
1	#5651.65	56.7 PK	69.4	-12.7	1.09 V	186	43.6	13.1
2	*5755.00	101.1 PK			1.09 V	186	57.7	43.4
3	*5755.00	92.5 AV			1.09 V	186	49.1	43.4
4	#5978.38	55.9 PK	68.2	-12.3	1.09 V	186	41.9	14.0
5	11510.00	57.2 PK	74.0	-16.8	1.75 V	55	37.3	19.9
6	11510.00	47.8 AV	54.0	-6.2	1.75 V	55	27.9	19.9

Remarks:

1. Emission Level(dBuV/m) = Raw Value(dBuV) + Correction Factor(dB/m)
2. Correction Factor(dB/m) = Antenna Factor(dB/m) + Cable Factor(dB) – Pre-Amplifier Factor(dB)
3. Margin value = Emission Level – Limit value
4. The other emission levels were very low against the limit.
5. " * " : Fundamental frequency, the limit was restricted at the RF Output Power.
6. " # " : The radiated frequency is out of the restricted band.



RF Mode	802.11n (HT40)	Channel	CH 159 : 5795 MHz
Frequency Range	1 GHz ~ 40 GHz	Detector Function & Bandwidth	PK: RB=1 MHz, VB=3 MHz, DET=Peak AV: RB=1 MHz, VB=10 Hz, DET=Peak
Input Power	120 Vac, 60 Hz	Environmental Conditions	25°C, 60% RH
Tested By	Charles Hsiao		

Antenna Polarity & Test Distance : Horizontal at 3 m

No	Frequency (MHz)	Emission Level (dBuV/m)	Limit (dBuV/m)	Margin (dB)	Antenna Height (m)	Table Angle (Degree)	Raw Value (dBuV)	Correction Factor (dB/m)
1	#5648.45	55.9 PK	68.2	-12.3	1.46 H	53	42.8	13.1
2	*5795.00	104.1 PK			1.46 H	53	60.7	43.4
3	*5795.00	95.3 AV			1.46 H	53	51.9	43.4
4	#5989.59	56.4 PK	68.2	-11.8	1.46 H	53	42.4	14.0
5	11590.00	57.5 PK	74.0	-16.5	1.67 H	200	37.5	20.0
6	11590.00	48.2 AV	54.0	-5.8	1.67 H	200	28.2	20.0

Antenna Polarity & Test Distance : Vertical at 3 m

No	Frequency (MHz)	Emission Level (dBuV/m)	Limit (dBuV/m)	Margin (dB)	Antenna Height (m)	Table Angle (Degree)	Raw Value (dBuV)	Correction Factor (dB/m)
1	#5648.85	55.4 PK	68.2	-12.8	1.09 V	190	42.3	13.1
2	*5795.00	101.2 PK			1.09 V	190	57.8	43.4
3	*5795.00	92.4 AV			1.09 V	190	49.0	43.4
4	#5987.59	56.4 PK	68.2	-11.8	1.09 V	190	42.4	14.0
5	11590.00	57.3 PK	74.0	-16.7	1.45 V	5	37.3	20.0
6	11590.00	47.8 AV	54.0	-6.2	1.45 V	5	27.8	20.0

Remarks:

1. Emission Level(dBuV/m) = Raw Value(dBuV) + Correction Factor(dB/m)
2. Correction Factor(dB/m) = Antenna Factor(dB/m) + Cable Factor(dB) – Pre-Amplifier Factor(dB)
3. Margin value = Emission Level – Limit value
4. The other emission levels were very low against the limit.
5. " * " : Fundamental frequency, the limit was restricted at the RF Output Power.
6. " # " : The radiated frequency is out of the restricted band.

Plot of Band Edge

Frequency Range	4.5 GHz ~ 5.46 GHz	Detector Function & Bandwidth	PK: RB=1 MHz, VB=3 MHz, DET=Peak AV: RB=1 MHz, VB=10 Hz, DET=Peak
-----------------	--------------------	-------------------------------	--

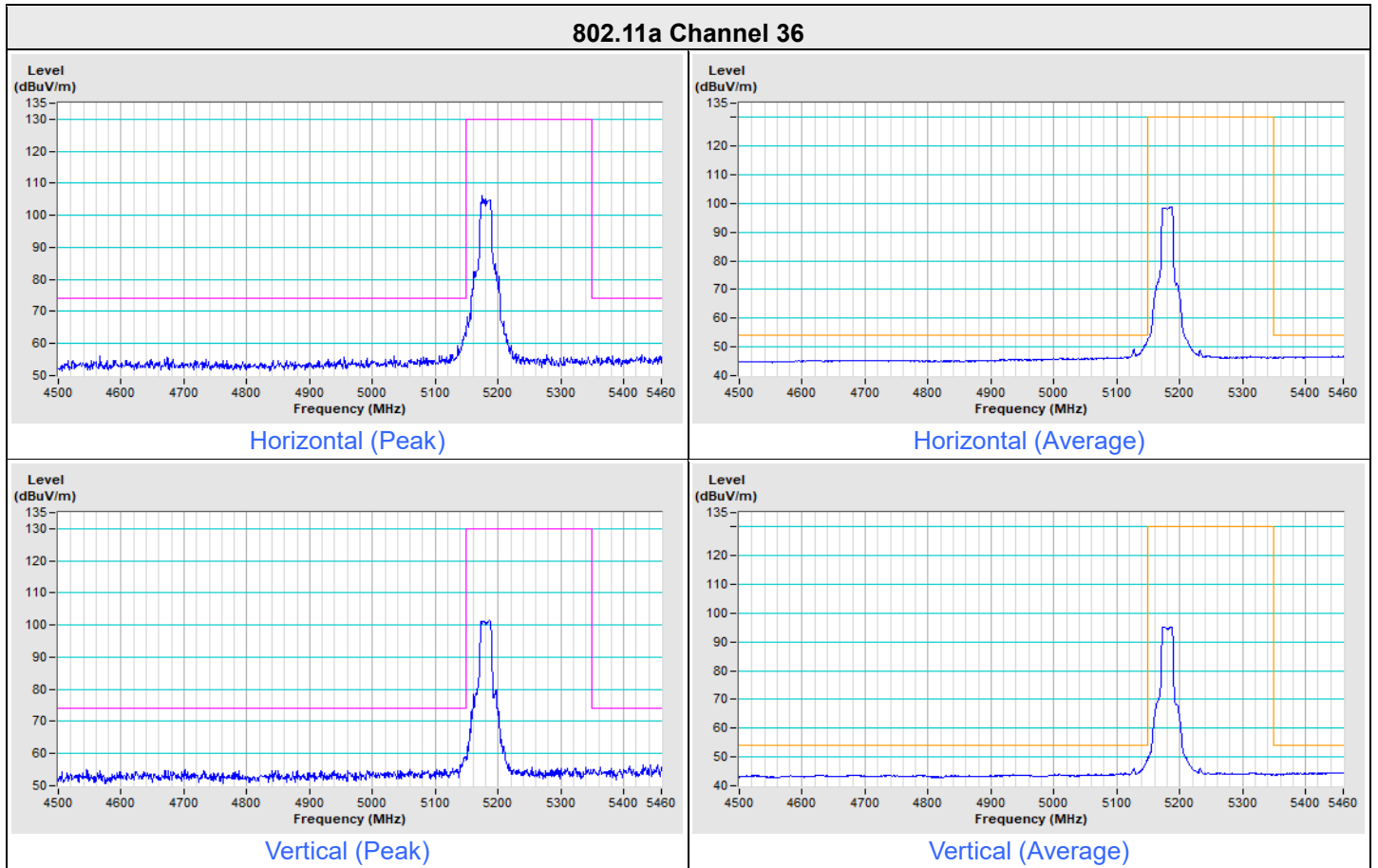

802.11a Channel 48

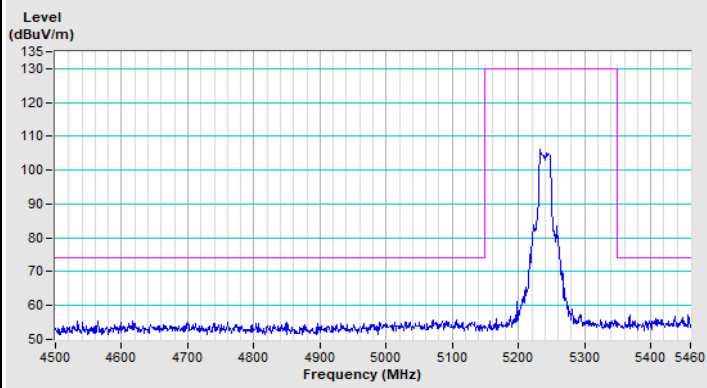

Horizontal (Peak)

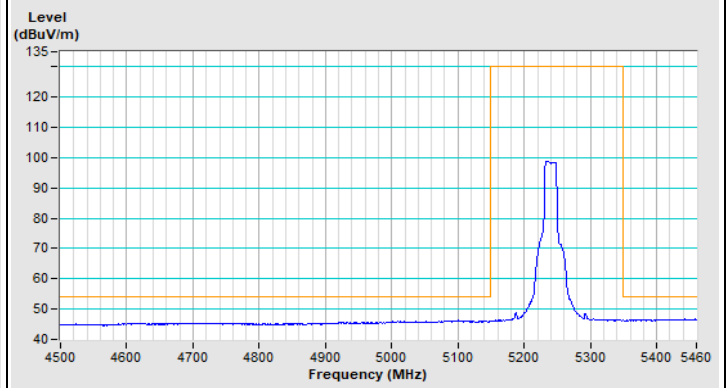

Horizontal (Average)

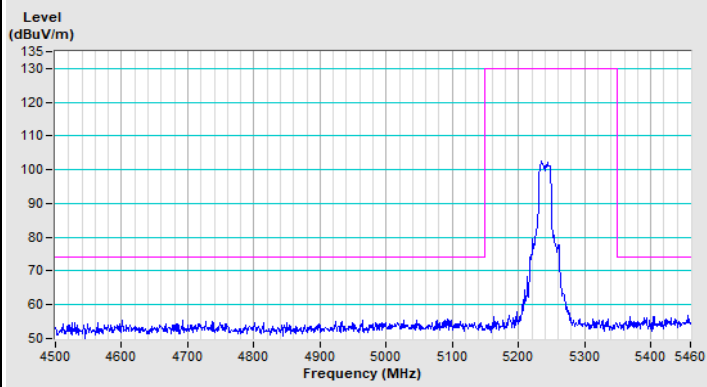

Vertical (Peak)

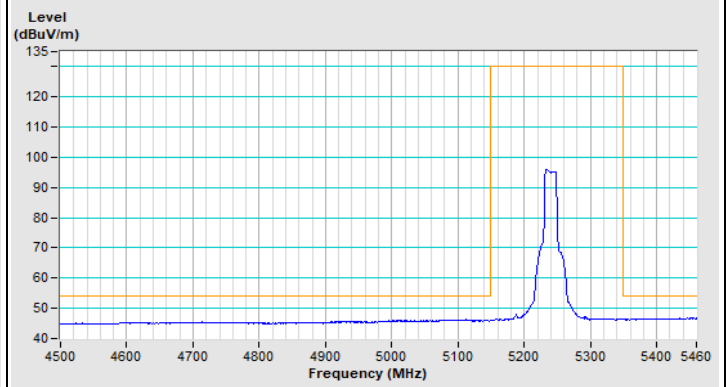

Vertical (Average)

Frequency Range	4.5 GHz ~ 5.46 GHz	Detector Function & Bandwidth	PK: RB=1 MHz, VB=3 MHz, DET=Peak AV: RB=1 MHz, VB=10 Hz, DET=Peak
-----------------	--------------------	-------------------------------	--

802.11n (HT20) Channel 36

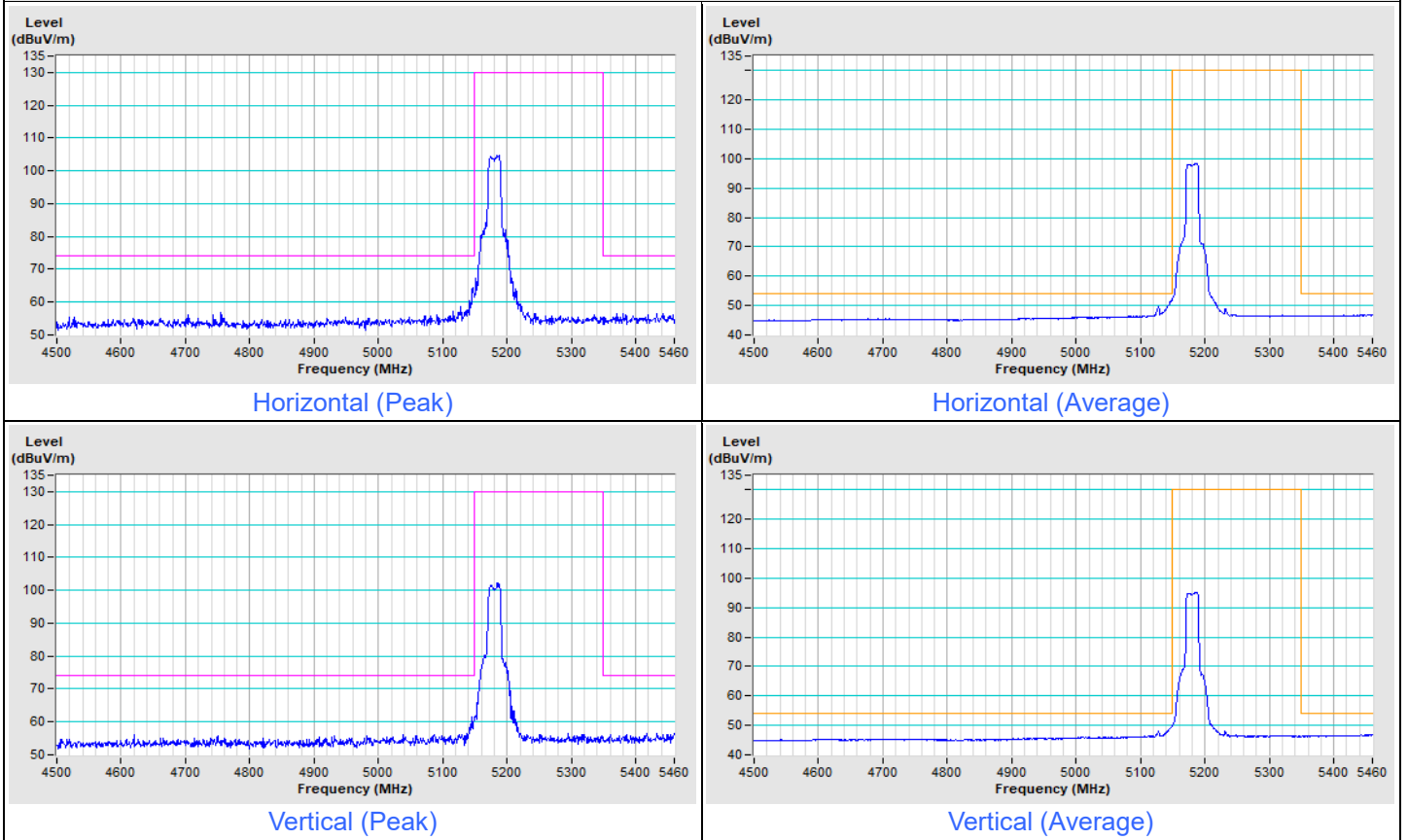

802.11n (HT20) Channel 48

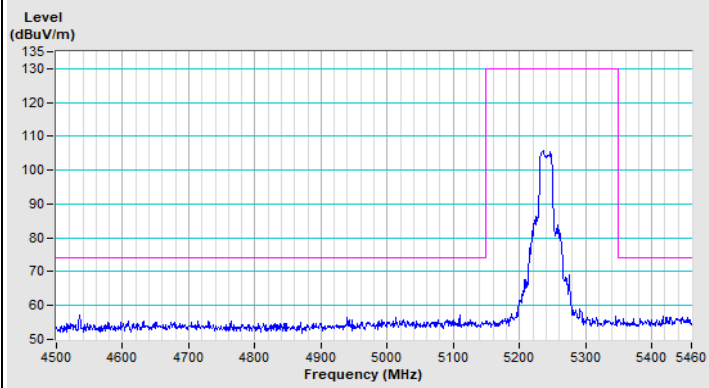

Horizontal (Peak)

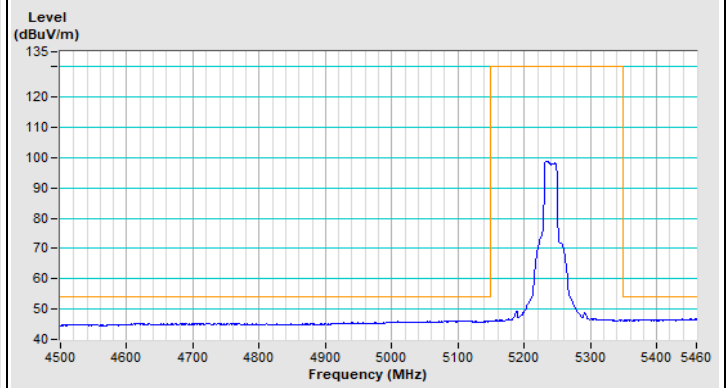

Horizontal (Average)

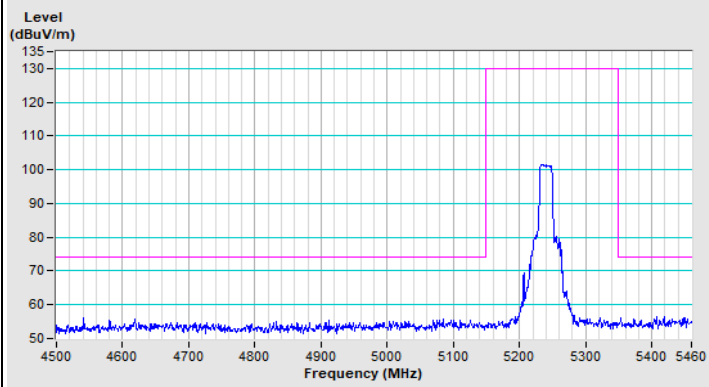

Vertical (Peak)

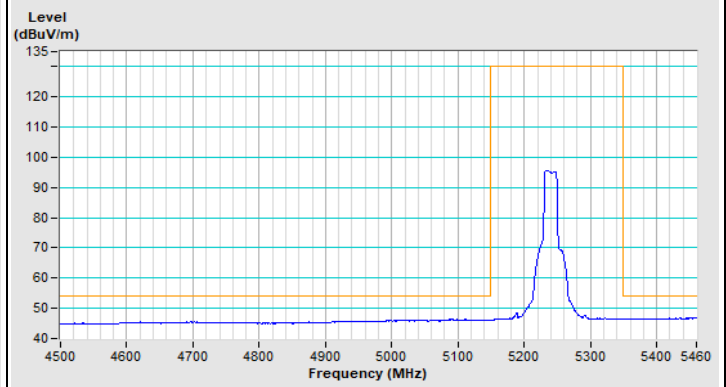

Vertical (Average)

Frequency Range	4.5 GHz ~ 5.46 GHz	Detector Function & Bandwidth	PK: RB=1 MHz, VB=3 MHz, DET=Peak AV: RB=1 MHz, VB=10 Hz, DET=Peak
-----------------	--------------------	-------------------------------	--

802.11n (HT40) Channel 38

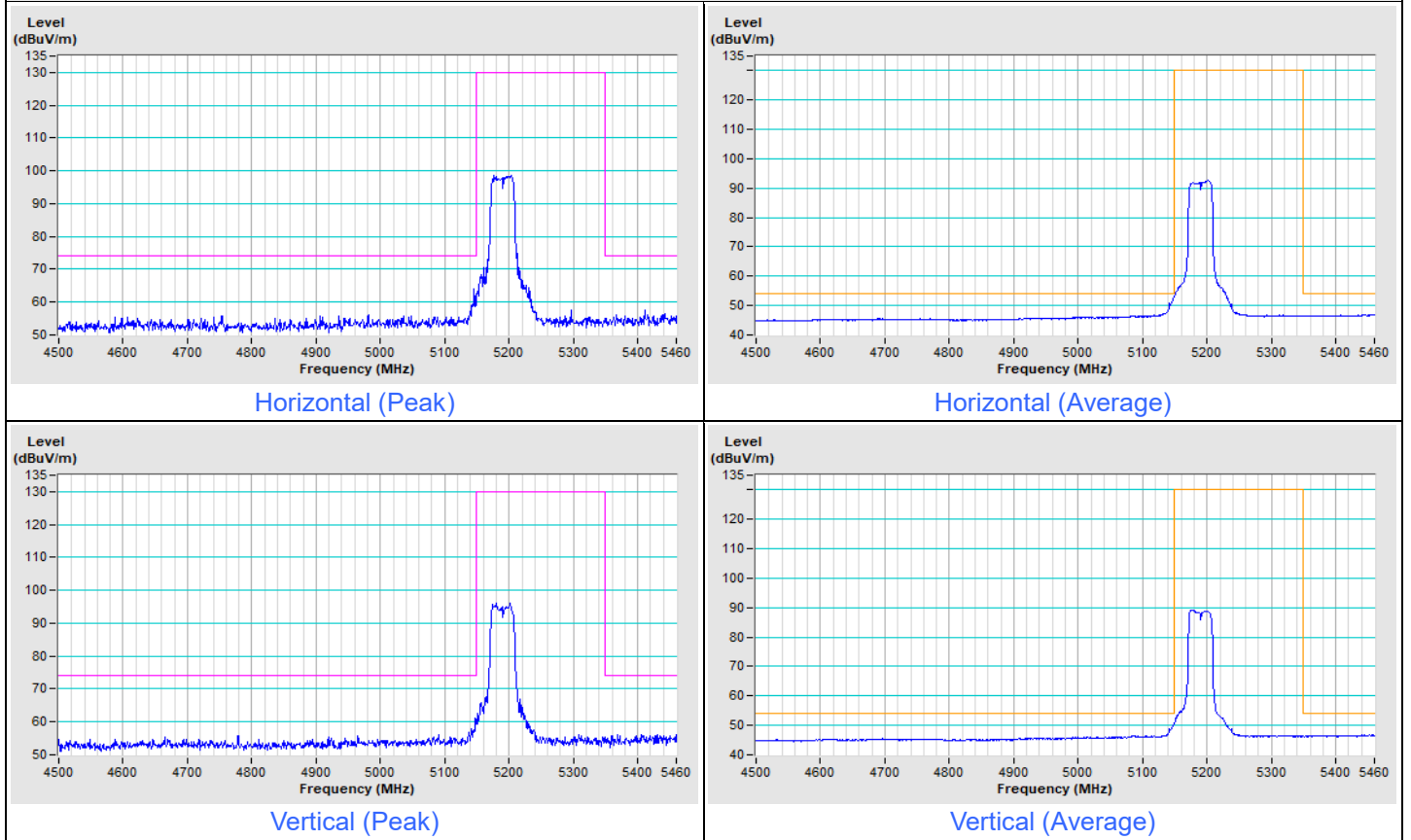

802.11n (HT40) Channel 46

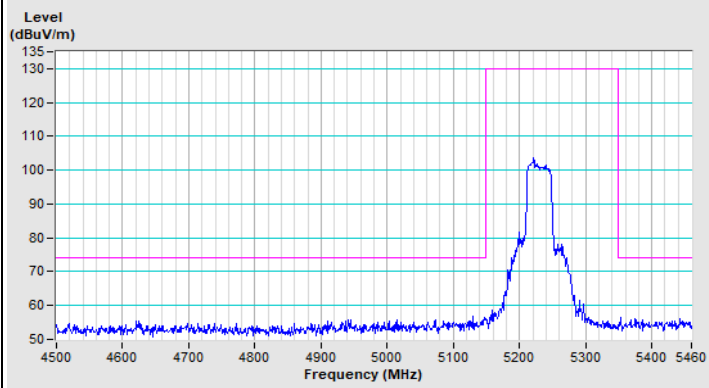

Horizontal (Peak)

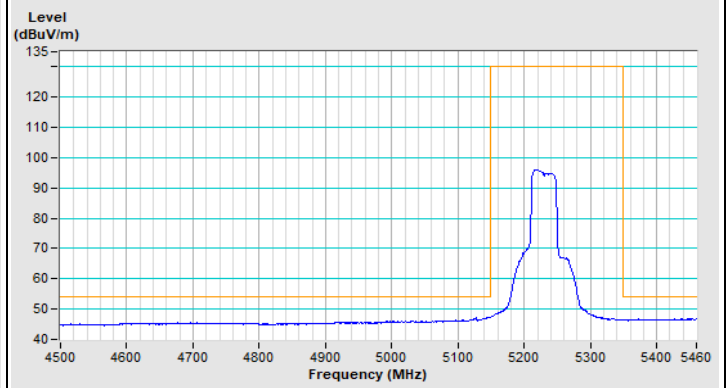

Horizontal (Average)

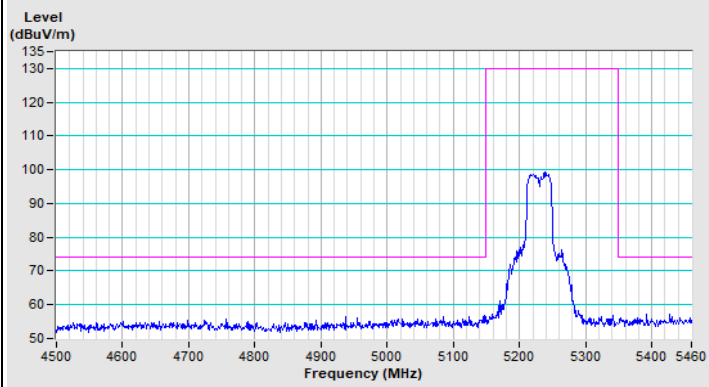

Vertical (Peak)

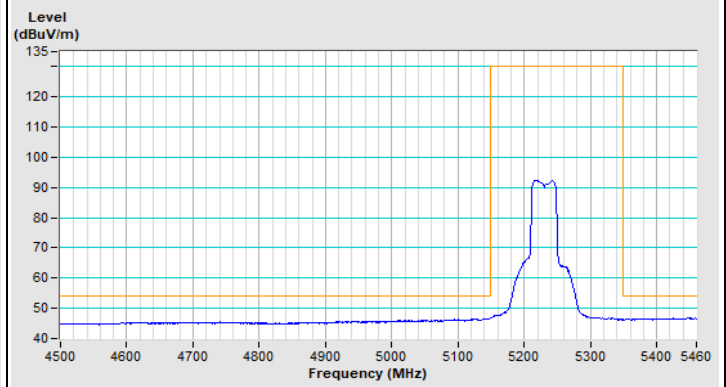

Vertical (Average)

Frequency Range	5.6 GHz ~ 6 GHz	Detector Function & Bandwidth	PK: RB=1 MHz, VB=3 MHz, DET=Peak
-----------------	-----------------	-------------------------------	----------------------------------

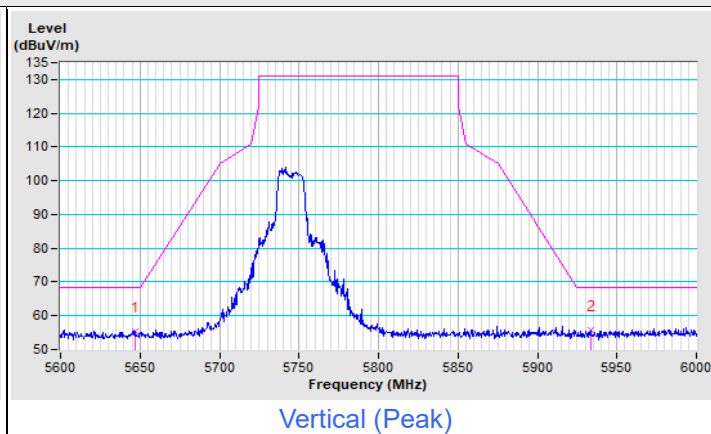
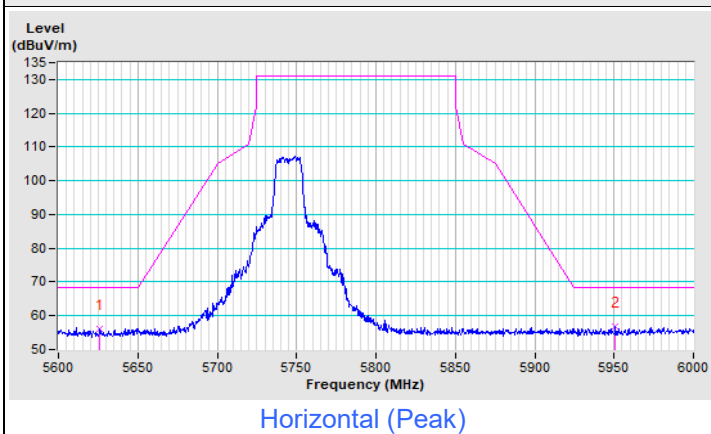
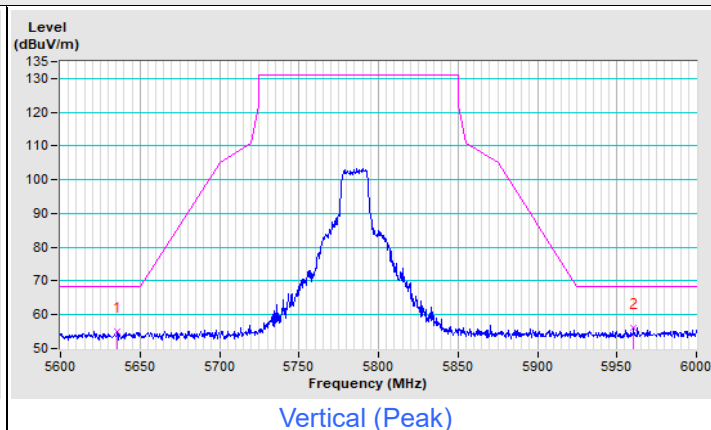
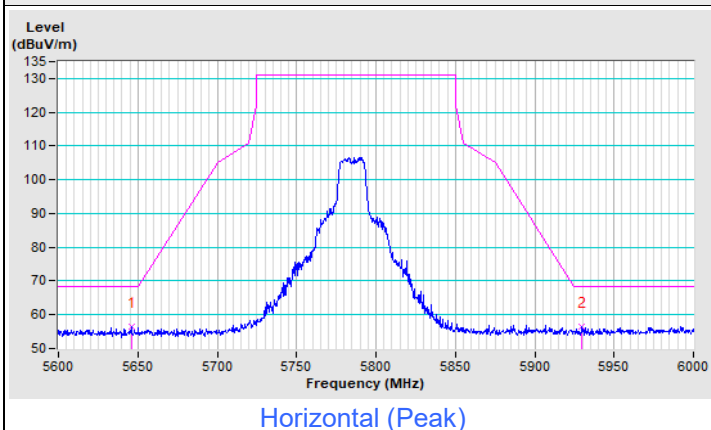
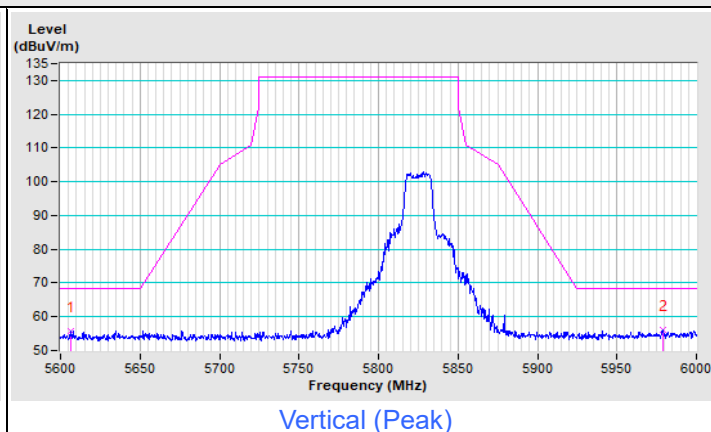
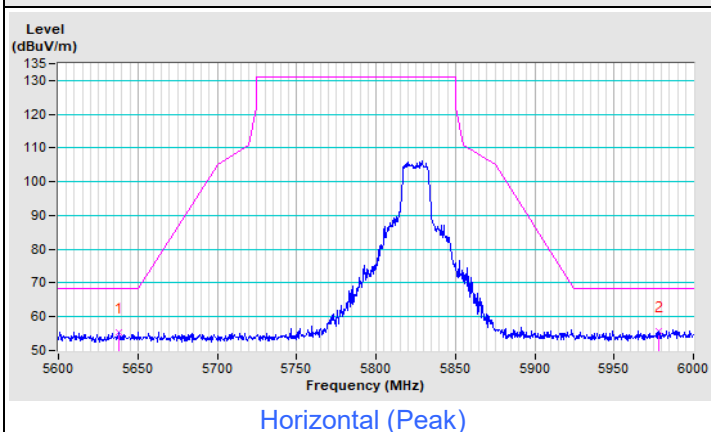
802.11a Channel 149**802.11a Channel 157****802.11a Channel 165**



Frequency Range	5.6 GHz ~ 6 GHz	Detector Function & Bandwidth	PK: RB=1 MHz, VB=3 MHz, DET=Peak
-----------------	-----------------	-------------------------------	----------------------------------

802.11n (HT20) Channel 149

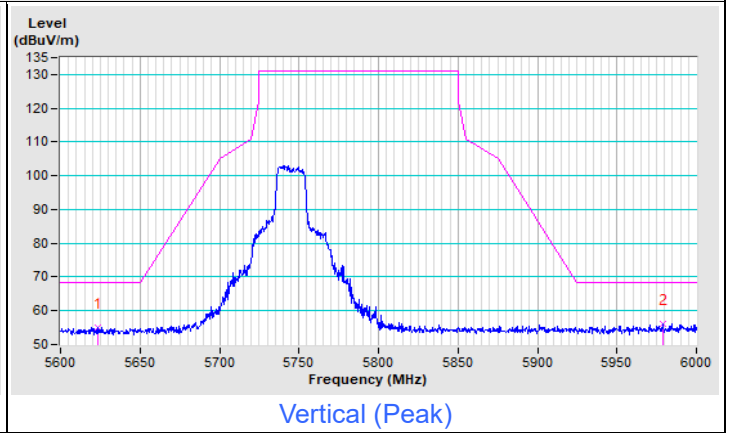
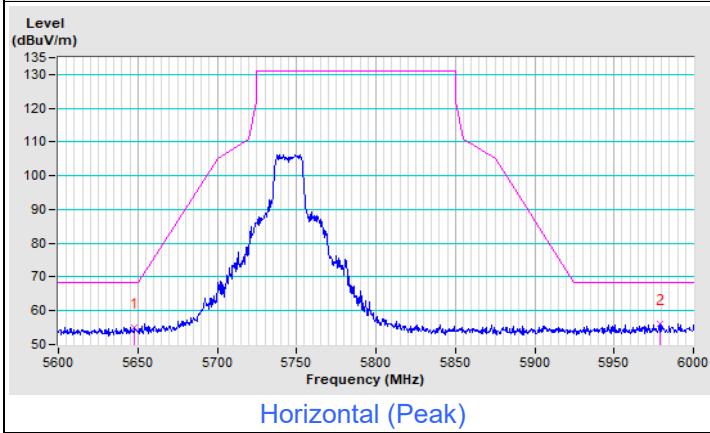

802.11n (HT20) Channel 157

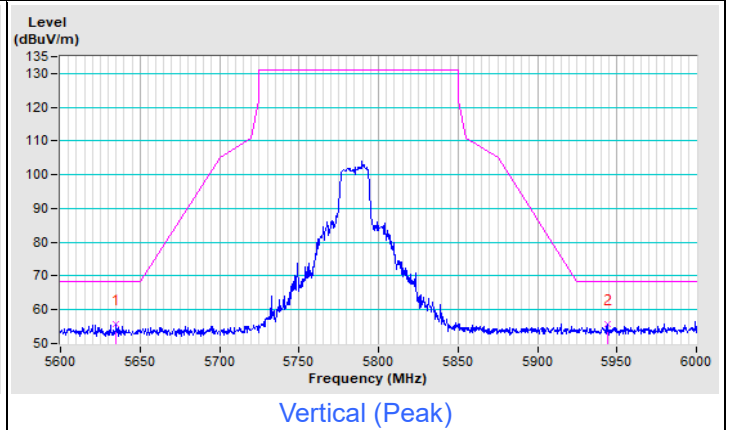
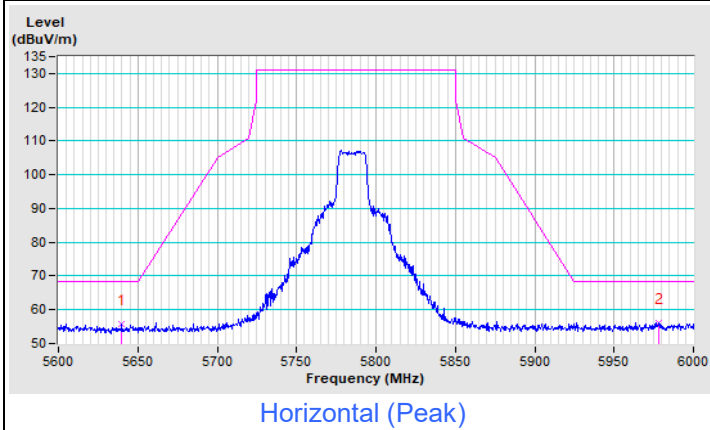

802.11n (HT20) Channel 165

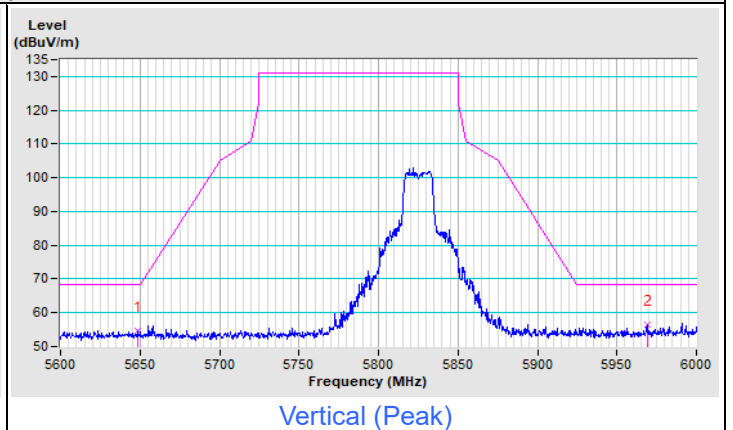
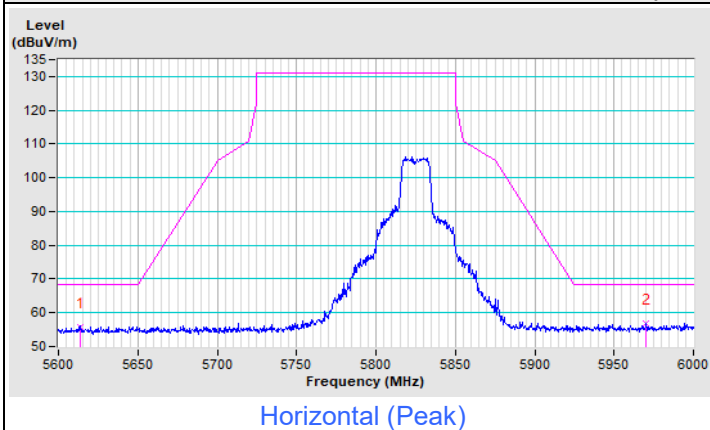

Frequency Range	5.6 GHz ~ 6 GHz	Detector Function & Bandwidth	PK: RB=1 MHz, VB=3 MHz, DET=Peak
-----------------	-----------------	-------------------------------	----------------------------------

802.11n (HT40) Channel 151

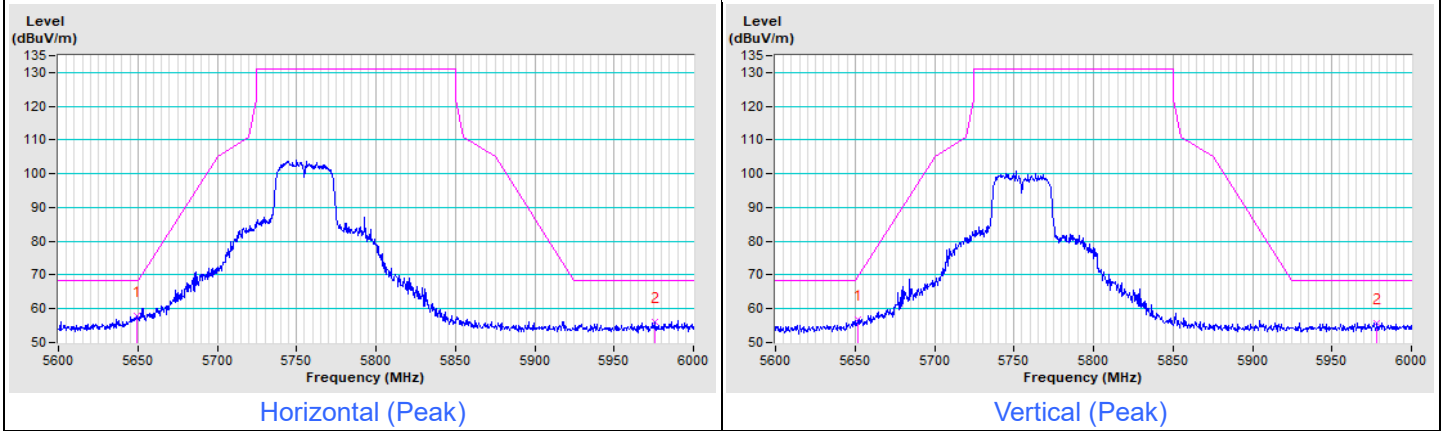

802.11n (HT40) Channel 159

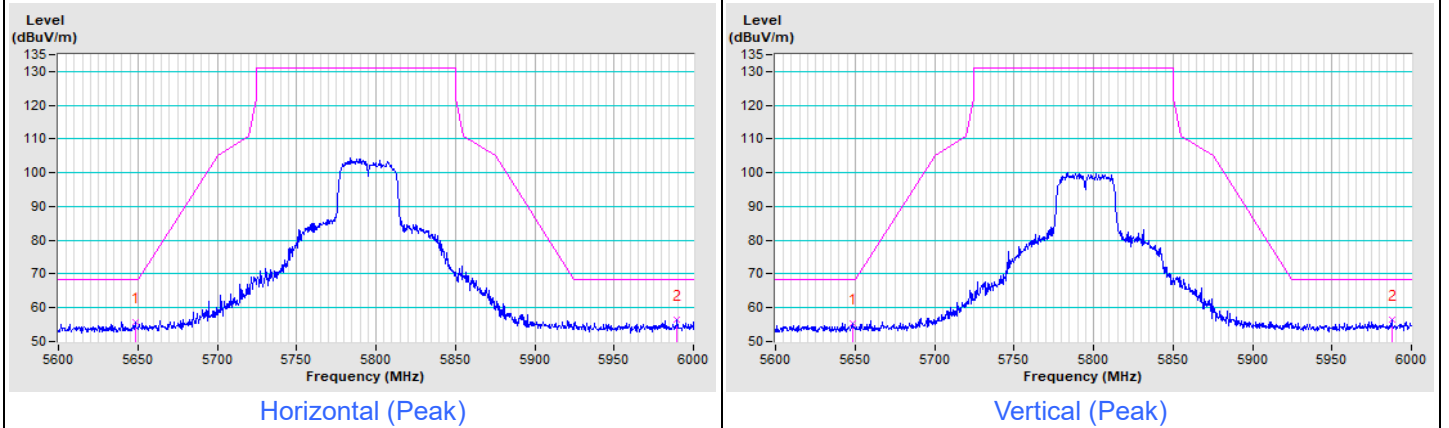

8 Pictures of Test Arrangements

Please refer to the attached file (Test Setup Photo)

9 Information of the Testing Laboratories

We, Bureau Veritas Consumer Products Services (H.K.) Ltd., Taoyuan Branch, were founded in 1988 to provide our best service in EMC, Radio, Telecom and Safety consultation. Our laboratories are FCC recognized accredited test firms and accredited according to ISO/IEC 17025.

If you have any comments, please feel free to contact us at the following:

Lin Kou EMC/RF Lab

Tel: 886-2-26052180

Fax: 886-2-26051924

Hsin Chu EMC/RF/Telecom Lab

Tel: 886-3-6668565

Fax: 886-3-6668323

Hwa Ya EMC/RF/Safety Lab

Tel: 886-3-3183232

Fax: 886-3-3270892

Email: service.adt@bureauveritas.com

Web Site: <http://ee.bureauveritas.com.tw>

The address and road map of all our labs can be found in our web site also.

--- END ---