

Partial FCC Test Report

(PART 24)

Report No.: RFBBGM-WTW-P21120256-1

FCC ID: WIYLE910C1NF

Test Model: LE910C1-NF

Received Date: Nov. 24, 2021

Test Date: Dec. 07, 2021

Issued Date: Jan. 10, 2022

Applicant: CASTLES TECHNOLOGY CO., LTD.

Address: 6F, NO. 207-5, SEC. 3, BEIXIN RD., XINDIAN DISTRICT, NEW TAIPEI CITY 23143, TAIWAN (R. O. C.)

Issued By: Bureau Veritas Consumer Products Services (H.K.) Ltd., Taoyuan Branch
Lin Kou Laboratories

Lab Address: No. 47-2, 14th Ling, Chia Pau Vil., Lin Kou Dist., New Taipei City, Taiwan

Test Location: No.70, Wenming Rd., Guishan Dist., Taoyuan City 333, Taiwan (R.O.C)

**FCC Registration /
Designation Number:** 281270 / TW0032



This report is for your exclusive use. Any copying or replication of this report to or for any other person or entity, or use of our name or trademark, is permitted only with our prior written permission. This report sets forth our findings solely with respect to the test samples identified herein. The results set forth in this report are not indicative or representative of the quality or characteristics of the lot from which a test sample was taken or any similar or identical product unless specifically and expressly noted. Our report includes all of the tests requested by you and the results thereof based upon the information that you provided to us. You have 60 days from date of issuance of this report to notify us of any material error or omission caused by our negligence, provided, however, that such notice shall be in writing and shall specifically address the issue you wish to raise. A failure to raise such issue within the prescribed time shall constitute your unqualified acceptance of the completeness of this report, the tests conducted and the correctness of the report contents. Unless specific mention, the uncertainty of measurement has been explicitly taken into account to declare the compliance or non-compliance to the specification.

Table of Contents

Release Control Record	3
1 Certificate of Conformity	4
2 Summary of Test Results	5
2.1 Measurement Uncertainty	5
2.2 Test Site and Instruments	6
3 General Information	7
3.1 General Description of EUT	7
3.2 Configuration of System under Test.....	8
3.2.1 Description of Support Units	8
3.3 Test Mode Applicability and Tested Channel Detail	9
3.4 EUT Operating Conditions	9
3.5 General Description of Applied Standards and references.....	10
4 Test Types and Results	11
4.1 Output Power Measurement	11
4.1.1 Limits of Output Power Measurement	11
4.1.2 Test Procedures.....	11
4.1.3 Test Setup	11
4.1.4 Test Results	12
4.2 Radiated Emission Measurement	14
4.2.1 Limits of Radiated Emission Measurement	14
4.2.2 Test Procedure	14
4.2.3 Deviation from Test Standard	14
4.2.4 Test Setup	15
4.2.5 Test Results	16
5 Pictures of Test Arrangements	22
Appendix – Information of the Testing Laboratories	23

Release Control Record

Issue No.	Description	Date Issued
RFBBGM-WTW-P21120256-1	Original Release	Jan. 10, 2022

1 Certificate of Conformity

Product: WCDMA and LTE cellular wireless module

Brand:  CASTLES
TECHNOLOGY

Test Model: LE910C1-NF

Sample Status: Identical Prototype

Applicant: CASTLES TECHNOLOGY CO., LTD.

Test Date: Dec. 07, 2021

Standards: FCC Part 24, Subpart E

The above equipment has been tested by **Bureau Veritas Consumer Products Services (H.K.) Ltd., Taoyuan Branch**, and found compliance with the requirement of the above standards. The test record, data evaluation & Equipment Under Test (EUT) configurations represented herein are true and accurate accounts of the measurements of the sample's RF characteristics under the conditions specified in this report.

Prepared by : Gina Liu, **Date:** Jan. 10, 2022
Gina Liu / Specialist

Approved by : Jeremy Lin, **Date:** Jan. 10, 2022
Dylan Chiou / Senior Engineer

2 Summary of Test Results

Applied Standard: FCC Part 24 & Part 2			
FCC Clause	Test Item	Result	Remarks
2.1046 24.232	Equivalent Isotropic Radiated Power	Pass	Meet the requirement of limit.
2.1047	Modulation Characteristics	N/A	Refer to Note
24.232(d)	Peak to Average Ratio	N/A	Refer to Note
2.1055 24.235	Frequency Stability	N/A	Refer to Note
2.1049	Occupied Bandwidth	N/A	Refer to Note
24.238	Band Edge Measurements	N/A	Refer to Note
2.1051 24.238	Conducted Spurious Emissions	N/A	Refer to Note
2.1053 24.238	Radiated Spurious Emissions	Pass	Meet the requirement of limit. Minimum passing margin is -20.44 dB at 892.33 MHz.

Note:

- This report is a partial report. Therefore, only test item of Equivalent Isotropic Radiated Power and Radiated Spurious Emissions tests were performed for this report. Other testing data please refer to DEKRA report no.: 1980255R-HPUSP17V00-B & 1980255R-HPUSP17V00-C (LTE Module, Brand: Telit, Model: LE910C4-NF, FCC ID: RI7LE910CXNF).
- Determining compliance based on the results of the compliance measurement, not taking into account measurement instrumentation uncertainty.

2.1 Measurement Uncertainty

Where relevant, the following measurement uncertainty levels have been estimated for tests performed on the EUT as specified in CISPR 16-4-2:

Measurement	Frequency	Expanded Uncertainty (k=2) (±)
Radiated Emissions up to 1 GHz	9 kHz ~ 30 MHz	3.04 dB
	30 MHz ~ 200 MHz	2.91 dB
	200 MHz ~ 1000 MHz	2.93 dB
Radiated Emissions above 1 GHz	1 GHz ~ 18 GHz	1.76 dB
	18 GHz ~ 40 GHz	1.77 dB

2.2 Test Site and Instruments

Description & Manufacturer	Model No.	Serial No.	Date of Calibration	Due Date of Calibration
Test Receiver KEYSIGHT	N9038B	MY60180018	Feb. 01, 2021	Jan. 31, 2022
Spectrum Analyzer KEYSIGHT	N9020B	MY60110513	Dec. 21, 2020	Dec. 20, 2021
BILOG Antenna SCHWARZBECK	VULB9168	9168-1214	Oct. 27, 2021	Oct. 26, 2022
HORN Antenna RF SPIN	DRH18-E	210101A18E	Nov. 14, 2021	Nov. 13, 2022
HORN Antenna SCHWARZBECK	BBHA 9170	9170-1049	Nov. 14, 2021	Nov. 13, 2022
Loop Antenna TESEQ	HLA 6121	45745	Jul. 21, 2021	Jul. 20, 2022
Preamplifier EMCI	EMC330N	980798	Jan. 19, 2021	Jan. 18, 2022
Preamplifier EMCI	EMC118A45SE	980809	Jan. 06, 2021	Jan. 05, 2022
Preamplifier EMCI	EMC184045SE	980786	Jan. 12, 2021	Jan. 11, 2022
RF signal cable EMCI	EMC104-SM-SM-(9000+2000+1000)	201244+ 201232+ 210103	Jan. 12, 2021	Jan. 11, 2022
RF signal cable EMCI	EMCCFD400-NM-NM-(9000+300+500)	201251+ 201249+ 201248	Jan. 12, 2021	Jan. 11, 2022
RF signal cable EMCI	EMC101G-KM-KM-(5000+3000+2000)	201261+201258+201249	Jan. 12, 2021	Jan. 11, 2022
Software BV ADT	ADT_Radiated_V7.6.15.9.5	NA	NA	NA
Antenna Tower Max-Full	MFA-515BSN	NA	NA	NA
Turn Table Max-Full	MFT-201SS	NA	NA	NA
Turn Table Controller Max-Full	MF-7802BS	MF780208676	NA	NA
Radio Communication Analyzer Anritsu	MT8821C	6201462755	Feb. 07, 2021	Feb. 06, 2022

Note: 1. The calibration interval of the above test instruments is 12 months and the calibrations are traceable to NML/ROC and NIST/USA.

2. The test was performed in WM Chamber 9.



3 General Information

3.1 General Description of EUT

Product	WCDMA and LTE cellular wireless module	
Brand		
Test Model	LE910C1-NF	
Status of EUT	Identical Prototype	
Power Supply Rating	5.0 Vdc (host equipment) 3.7 Vdc (Battery)	
Modulation Type	WCDMA	QPSK
	LTE	QPSK, 16QAM
Frequency Range	WCDMA	1852.4 ~ 1907.6 MHz
	LTE Band 2 (Channel Bandwidth: 1.4 MHz)	1850.7 ~ 1909.3 MHz
	LTE Band 2 (Channel Bandwidth: 3 MHz)	1851.5 ~ 1908.5 MHz
	LTE Band 2 (Channel Bandwidth: 5 MHz)	1852.5 ~ 1907.5 MHz
	LTE Band 2 (Channel Bandwidth: 10 MHz)	1855.0 ~ 1905.0 MHz
	LTE Band 2 (Channel Bandwidth: 15 MHz)	1857.5 ~ 1902.5 MHz
	LTE Band 2 (Channel Bandwidth: 20 MHz)	1860.0 ~ 1900.0 MHz
Max. EIRP Power	WCDMA	251.189 mW (24.00dBm)
	LTE Band 2 (Channel Bandwidth: 1.4 MHz)	243.220 mW (23.86dBm)
	LTE Band 2 (Channel Bandwidth: 3 MHz)	242.661 mW (23.85dBm)
	LTE Band 2 (Channel Bandwidth: 5 MHz)	240.436 mW (23.81dBm)
	LTE Band 2 (Channel Bandwidth: 10 MHz)	242.661 mW (23.85dBm)
	LTE Band 2 (Channel Bandwidth: 15 MHz)	245.471 mW (23.90dBm)
	LTE Band 2 (Channel Bandwidth: 20 MHz)	248.313 mW (23.95dBm)
Antenna Type	Dipole Antenna with 0.64 dBi gain	
Accessory Device	Refer to Note as below	
Data Cable Supplied	Refer to Note as below	

Note:

- The EUT was installed in POS Terminal (Brand:  , Model: VEGA3000).
- The EUT contains following accessory devices.

Product	Brand	Model	Description
USB Cable	CHANG YANG ELECTRON CO., LTD.	CY-AS-HK0059	1 m
AC adapter		1A52-UB52A	AC input : 100-240V~0.3A 50-60Hz DC output : 5V 2A 10W
Battery		V3M2	3.7V, 3100mAh, 11.47Wh

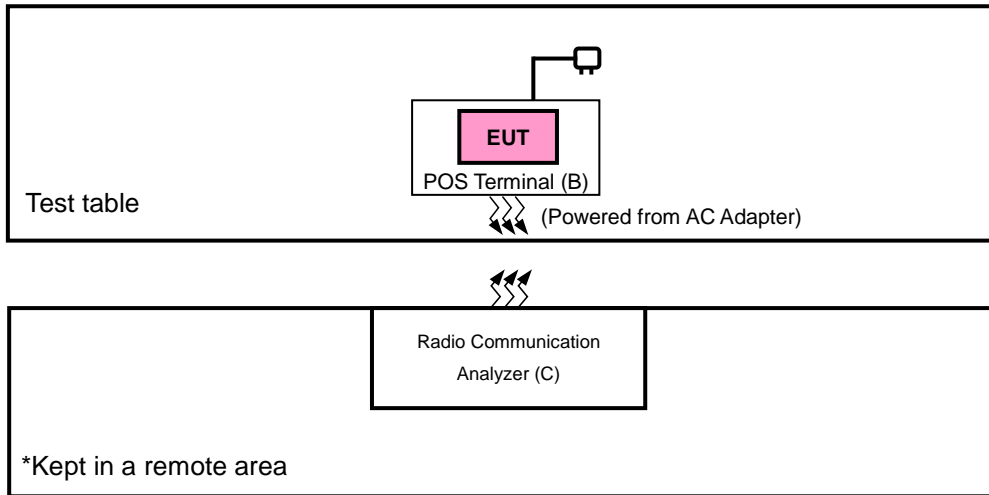

- The above Antenna information is declared by manufacturer and for more detailed features description, please refer to the manufacturer's specifications, the laboratory shall not be held responsible.
- The above EUT information is declared by manufacturer and for more detailed features description, please refers to the manufacturer's specifications or user's manual.

3.2 Configuration of System under Test



3.2.1 Description of Support Units

The EUT has been tested as an independent unit together with other necessary accessories or support units. The following support units or accessories were used to form a representative test configuration during the tests.

No.	Product	Brand	Model No.	Serial No.	FCC ID
A.	Adapter	 CASTLES TECHNOLOGY	1A52-UB52A	N/A	N/A
B.	POS Terminal	 CASTLES TECHNOLOGY	VEGA3000	N/A	N/A
C.	Radio Communication Analyzer	Anritsu	MT8821C	N/A	N/A

No.	Signal Cable Description Of The Above Support Units
1.	N/A

Note:

1. All power cords of the above support units are non-shielded (1.8m).
2. Item A-B was provided by client.

3.3 Test Mode Applicability and Tested Channel Detail

Pre-Scan has been conducted to determine the worst-case mode from all possible combinations between available modulations, data rates, XYZ axis, and antenna ports. The worst case was found when positioned on X-plane. Following channel(s) was (were) selected for the final test as listed below:

WCDMA

EUT Configure Mode	Test Item	Available Channel	Tested Channel	Mode
-	EIRP	9262 to 9538	9262, 9400, 9538	WCDMA
-	Radiated Emission	9262 to 9538	9400	WCDMA

LTE Band 2

EUT Configure Mode	Test Item	Available Channel	Tested Channel	Channel Bandwidth	Modulation	Mode
-	EIRP	18607 to 19193	18607, 18900, 19193	1.4 MHz	QPSK, 16QAM	1 RB / 0 RB Offset
		18615 to 19185	18615, 18900, 19185	3 MHz	QPSK, 16QAM	1 RB / 0 RB Offset
		18625 to 19175	18625, 18900, 19175	5 MHz	QPSK, 16QAM	1 RB / 0 RB Offset
		18650 to 19150	18650, 18900, 19150	10 MHz	QPSK, 16QAM	1 RB / 0 RB Offset
		18675 to 19125	18675, 18900, 19125	15 MHz	QPSK, 16QAM	1 RB / 0 RB Offset
		18700 to 19100	18700, 18900, 19100	20 MHz	QPSK, 16QAM	1 RB / 0 RB Offset
-	Radiated Emission	18615 to 19185	18900	3 MHz	QPSK	1 RB / 0 RB Offset

Test Condition:

Test Item	Environmental Conditions	Input Power	Tested By
EIRP	23 deg. C, 65 % RH	120 Vac, 60 Hz	Raymond Lee, Greg Lin
Radiated Emission	23 deg. C, 65 % RH	120 Vac, 60 Hz	Raymond Lee, Greg Lin

3.4 EUT Operating Conditions

The EUT makes a call to the communication simulator. The communication simulator station system controlled a EUT to export maximum output power under transmission mode and specific channel frequency

3.5 General Description of Applied Standards and references

The EUT is a RF Product. According to the specifications of the manufacturer, it must comply with the requirements of the following standards and references:

Test Standard:

FCC 47 CFR Part 2

FCC 47 CFR Part 24

ANSI 63.26-2015

NOTE: All test items have been performed and recorded as per the above standards.

References Test Guidance:

KDB 971168 D01 Power Meas License Digital Systems v03r01

ANSI/TIA/EIA-603-E 2016

NOTE: All test items have been performed as a reference to the above KDB test guidance.

4 Test Types and Results

4.1 Output Power Measurement

4.1.1 Limits of Output Power Measurement

Mobile / Portable station are limited to 2 watts e.i.r.p.

4.1.2 Test Procedures

Conducted Power Measurement:

The EUT was set up for the maximum power with WCDMA and LTE link data modulation and link up with simulator. Set the EUT to transmit under low, middle and high channel and record the power level shown on simulator.

Maximum EIRP / ERP

The relevant equation for determining the maximum ERP or EIRP from the measured RF output power is given in Equation as follows:

$$\text{EIRP} = P_{\text{Meas}} + G_{\text{T}}$$

$$\text{ERP} = P_{\text{Meas}} + G_{\text{T}} - 2.15$$

where

ERP or EIRP effective radiated power or equivalent isotropically radiated power, respectively
(expressed in the same units as P_{Meas} , e.g., dBm or dBW)

P_{Meas} measured transmitter output power or PSD, in dBm or dBW

G_{T} gain of the transmitting antenna, in dBd (ERP) or dBi (EIRP)

4.1.3 Test Setup

EIRP / ERP / Conducted Power Measurement:



4.1.4 Test Results

Conducted Output Power (dBm)

Band	WCDMA II		
Channel	9262	9400	9538
Frequency (MHz)	1852.4	1880.0	1907.6
RMC 12.2K	23.18	23.36	23.19
HSDPA Subtest-1	22.39	22.46	22.43
HSDPA Subtest-2	22.38	22.47	22.43
HSDPA Subtest-3	21.99	22	21.96
HSDPA Subtest-4	21.98	21.98	21.95
DC-HSDPA Subtest-1	21.69	21.66	21.73
DC-HSDPA Subtest-2	21.58	21.77	21.63
DC-HSDPA Subtest-3	21.19	21.24	21.26
DC-HSDPA Subtest-4	21.28	21.33	21.15
HSUPA Subtest-1	21.9	21.84	22.1
HSUPA Subtest-2	20.4	20.19	19.89
HSUPA Subtest-3	20.92	21.08	20.97
HSUPA Subtest-4	20.48	20.34	20.33
HSUPA Subtest-5	22.4	22.5	22.3

LTE Band 2																					
BW	MCS Index	RB Size	RB Offset	Low	Mid	High	3GPP MPR (dB)	BW	MCS Index	RB Size	RB Offset	Low	Mid	High	3GPP MPR (dB)						
				Channel								18675	18900	19125		Channel			18675	18900	19125
				Frequency (MHz)								1860.0	1880.0	1900.0		Frequency (MHz)			1857.5	1880.0	1902.5
20M	QPSK	1	0	23.22	23.31	23.29	0	15M	QPSK	1	0	23.2	23.26	23.2	0						
		1	50	23.14	23.23	23.21	0			1	37	23.13	23.14	23.17	0						
		1	99	23.18	23.27	23.25	0			1	74	23.12	23.26	23.18	0						
		50	0	22.28	22.37	22.35	1			36	0	22.19	22.35	22.26	1						
		50	25	22.2	22.29	22.27	1			36	19	22.15	22.25	22.18	1						
		50	50	22.16	22.25	22.23	1			36	39	22.12	22.2	22.21	1						
	100	0	22.14	22.23	22.21	1	75		0	22.14	22.14	22.16	1								
	16QAM	1	0	22.24	22.33	22.31	1		16QAM	1	0	22.22	22.31	22.21	1						
		1	50	22.17	22.26	22.24	1			1	37	22.24	22.16	22.14	1						
		1	99	22.14	22.23	22.21	1			1	74	22.08	22.13	22.18	1						
		50	0	21.23	21.32	21.3	2			36	0	21.21	21.24	21.29	2						
		50	25	21.19	21.28	21.26	2			36	19	21.18	21.21	21.21	2						
50		50	21.15	21.24	21.22	2	36	39		21.06	21.16	21.13	2								
100	0	21.16	21.25	21.23	2	75	0	21.07	21.16	21.2	2										
10M	QPSK	1	0	23.13	23.21	23.2	0	5M	QPSK	1	0	23.05	23.17	23.16	0						
		1	24	22.95	23.06	23.18	0			1	12	23.03	23.15	22.95	0						
		1	49	23.03	23.1	23.18	0			1	24	23.02	23.05	23.08	0						
		25	0	22.2	22.33	22.17	1			12	0	22.26	22.3	22.06	1						
		25	12	22.11	22.2	22.12	1			12	6	22.09	22.17	22.04	1						
		25	25	22.1	22.07	22.19	1			12	13	22.11	22.15	22.08	1						
	50	0	22.03	22.01	22.11	1	25		0	21.98	22.09	21.96	1								
	16QAM	1	0	22.04	22.18	22.2	1		16QAM	1	0	22.17	22.19	22.13	1						
		1	24	21.95	22.26	22.07	1			1	12	22.02	22.06	22.1	1						
		1	49	21.97	22.14	21.99	1			1	24	22.05	22.16	22.13	1						
		25	0	21.09	21.16	21.24	2			12	0	21.16	21.15	21.15	2						
		25	12	21.03	21.1	21.12	2			12	6	21.08	21.24	21.19	2						
25		25	20.96	21.08	21.02	2	12	13		20.98	21.18	21.15	2								
50	0	21.06	21.06	21.16	2	25	0	20.95	21.12	21.05	2										
3M	QPSK	1	0	23.21	23.2	23.15	0	1.4M	QPSK	1	0	23.08	23.16	23.17	0						
		1	7	22.97	23.14	23.14	0			1	2	22.92	23.05	23.03	0						
		1	14	23.09	23.15	23.12	0			1	5	22.99	23.13	23.15	0						
		8	0	22.14	22.28	22.17	1			3	0	23.21	23.22	23.15	0						
		8	3	22.08	22.25	22.2	1			3	1	23.07	23.15	23.15	0						
		8	7	21.98	22.11	22.08	1			3	3	23.07	23.11	23.17	0						
	15	0	22.06	22.12	21.97	1	6		0	22.05	22.08	22.18	1								
	16QAM	1	0	22.22	22.18	22.13	1		16QAM	1	0	22.13	22.25	22.21	1						
		1	7	21.97	22.2	22.05	1			1	2	22.02	22.22	22.19	1						
		1	14	22.09	22.09	22.02	1			1	5	21.95	22.13	22.13	1						
		8	0	21.11	21.2	21.12	2			3	0	22.23	22.18	22.21	1						
		8	3	21.07	21.25	21.11	2			3	1	22.04	22.13	22.08	1						
8		7	21.05	21.15	21.01	2	3	3		22.09	22.08	22.07	1								
15	0	21.11	21.06	21.09	2	6	0	20.97	21.14	21.12	2										

EIRP Power (dBm)

Band	WCDMA II		
Channel	9262	9400	9538
Frequency (MHz)	1852.4	1880.0	1907.6
RMC 12.2K	23.82	24	23.83
HSDPA Subtest-1	23.03	23.1	23.07
HSDPA Subtest-2	23.02	23.11	23.07
HSDPA Subtest-3	22.63	22.64	22.6
HSDPA Subtest-4	22.62	22.62	22.59
DC-HSDPA Subtest-1	22.33	22.3	22.37
DC-HSDPA Subtest-2	22.22	22.41	22.27
DC-HSDPA Subtest-3	21.83	21.88	21.9
DC-HSDPA Subtest-4	21.92	21.97	21.79
HSUPA Subtest-1	22.54	22.48	22.74
HSUPA Subtest-2	21.04	20.83	20.53
HSUPA Subtest-3	21.56	21.72	21.61
HSUPA Subtest-4	21.12	20.98	20.97
HSUPA Subtest-5	23.04	23.14	22.94

LTE Band 2																	
BW	MCS Index	RB Size	RB Offset	Low	Mid	High	3GPP MPR (dB)	BW	MCS Index	RB Size	RB Offset	Low	Mid	High	3GPP MPR (dB)		
				Channel	18700	18900						19100	Channel	18675		18900	19125
				Frequency (MHz)	1860.0	1880.0						1900.0	Frequency (MHz)	1857.5		1880.0	1902.5
20M	QPSK	1	0	23.86	23.95	23.93	0	15M	QPSK	1	0	23.84	23.9	23.84	0		
		1	50	23.78	23.87	23.85	0			1	37	23.77	23.78	23.81	0		
		1	99	23.82	23.91	23.89	0			1	74	23.76	23.9	23.82	0		
		50	0	22.92	23.01	22.99	1			36	0	22.83	22.99	22.9	1		
		50	25	22.84	22.93	22.91	1			36	19	22.79	22.89	22.82	1		
		50	50	22.8	22.89	22.87	1			36	39	22.76	22.84	22.85	1		
		100	0	22.78	22.87	22.85	1			75	0	22.78	22.78	22.8	1		
	16QAM	1	0	22.88	22.97	22.95	1		16QAM	1	0	22.86	22.95	22.85	1		
		1	50	22.81	22.9	22.88	1			1	37	22.78	22.8	22.78	1		
		1	99	22.78	22.87	22.85	1			1	74	22.72	22.77	22.82	1		
		50	0	21.87	21.96	21.94	2			36	0	21.85	21.88	21.93	2		
		50	25	21.83	21.92	21.9	2			36	19	21.82	21.85	21.85	2		
		50	50	21.79	21.88	21.86	2			36	39	21.7	21.8	21.77	2		
		100	0	21.8	21.89	21.87	2			75	0	21.71	21.8	21.84	2		
10M	QPSK	1	0	23.77	23.85	23.84	0	5M	QPSK	1	0	23.69	23.81	23.8	0		
		1	24	23.59	23.7	23.82	0			1	12	23.67	23.79	23.59	0		
		1	49	23.67	23.74	23.82	0			1	24	23.66	23.69	23.72	0		
		25	0	22.84	22.97	22.81	1			12	0	22.9	22.94	22.7	1		
		25	12	22.75	22.84	22.76	1			12	6	22.73	22.81	22.68	1		
		25	25	22.74	22.71	22.83	1			12	13	22.75	22.79	22.72	1		
		50	0	22.67	22.65	22.75	1			25	0	22.62	22.73	22.6	1		
	16QAM	1	0	22.68	22.82	22.84	1		16QAM	1	0	22.81	22.83	22.77	1		
		1	24	22.59	22.9	22.71	1			1	12	22.66	22.7	22.74	1		
		1	49	22.61	22.78	22.63	1			1	24	22.69	22.8	22.77	1		
		25	0	21.73	21.8	21.88	2			12	0	21.8	21.79	21.79	2		
		25	12	21.67	21.74	21.76	2			12	6	21.72	21.88	21.83	2		
		25	25	21.6	21.72	21.66	2			12	13	21.62	21.82	21.79	2		
		50	0	21.7	21.7	21.8	2			25	0	21.59	21.76	21.69	2		
3M	QPSK	1	0	23.85	23.84	23.79	0	1.4M	QPSK	1	0	23.72	23.8	23.81	0		
		1	7	23.61	23.78	23.78	0			1	2	23.56	23.69	23.67	0		
		1	14	23.73	23.79	23.76	0			1	5	23.63	23.77	23.79	0		
		8	0	22.78	22.92	22.81	1			3	0	23.85	23.86	23.79	0		
		8	3	22.72	22.89	22.84	1			3	1	23.71	23.79	23.79	0		
		8	7	22.62	22.75	22.72	1			3	3	23.71	23.75	23.81	0		
		15	0	22.7	22.76	22.61	1			6	0	22.69	22.72	22.82	1		
	16QAM	1	0	22.86	22.82	22.77	1		16QAM	1	0	22.77	22.89	22.85	1		
		1	7	22.61	22.84	22.69	1			1	2	22.66	22.86	22.83	1		
		1	14	22.73	22.73	22.66	1			1	5	22.59	22.77	22.77	1		
		8	0	21.75	21.84	21.76	2			3	0	22.87	22.82	22.85	1		
		8	3	21.71	21.89	21.75	2			3	1	22.68	22.77	22.72	1		
		8	7	21.69	21.79	21.65	2			3	3	22.73	22.72	22.71	1		
		15	0	21.75	21.7	21.73	2			6	0	21.61	21.78	21.76	2		

4.2 Radiated Emission Measurement

4.2.1 Limits of Radiated Emission Measurement

The power of any emission outside of the authorized operating frequency ranges must be attenuated below the transmitting power (P) by a factor of at least $43 + 10 \log(P)$ dB. The emission limit is equal to -13 dBm.

4.2.2 Test Procedure

- a. In the semi-anechoic chamber, EUT placed on the 0.8m(below or equal 1GHz) and/or 1.5m(above 1GHz) height of Turn Table, rotated the table around 360 degrees to search the maximum radiation power and receiver antenna shall be rotated vertical and horizontal polarization and moved height from 1m to 4m to find the maximum polar radiated power. The "Read Value" is the spectrum reading the maximum power value.
- b. The height of antenna is varied from one meter to four meters above the ground to determine the maximum value of the field strength. Both horizontal and vertical polarizations of the antenna are set to make the measurement.
- c. Perform a field strength measurement and record the worse read value, is the field strength value via a spectrum reading obtained corrected for antenna factor, cable loss and pre-amplifier factor and then mathematically convert the measured field strength level to EIRP/ERP level.
- d. Following C63.26 section 5.5 and 5.2.7
EIRP (dBm) = $E \text{ (dB}\mu\text{V/m)} + 20\log(D) - 104.8$; where D is the measurement distance (in the far field region) in m.
ERP (dBm) = $E \text{ (dB}\mu\text{V/m)} + 20\log(D) - 104.8 - 2.15$; where D is the measurement distance (in the far field region) in m.

NOTE:

1. The resolution bandwidth and video bandwidth of test receiver/spectrum analyzer is 1 MHz/3 MHz.
2. The emission levels were against the limit of frequency range 9 kHz ~ 30 MHz:

The amplitude of spurious emissions attenuated more than 20 dB below the permissible value is not required to be report.

4.2.3 Deviation from Test Standard

No deviation.

4.2.4 Test Setup

<Radiated Emission below or equal 1 GHz>

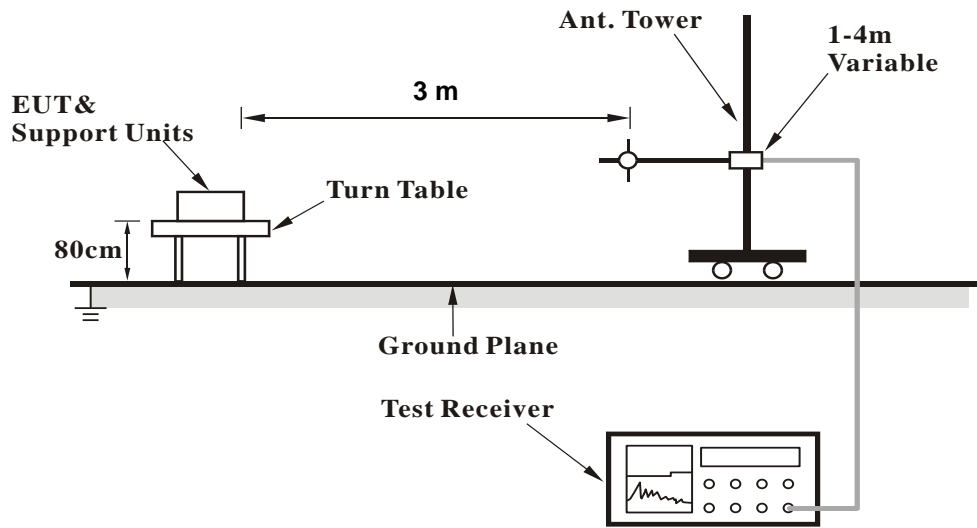

<Radiated Emission above 1 GHz>

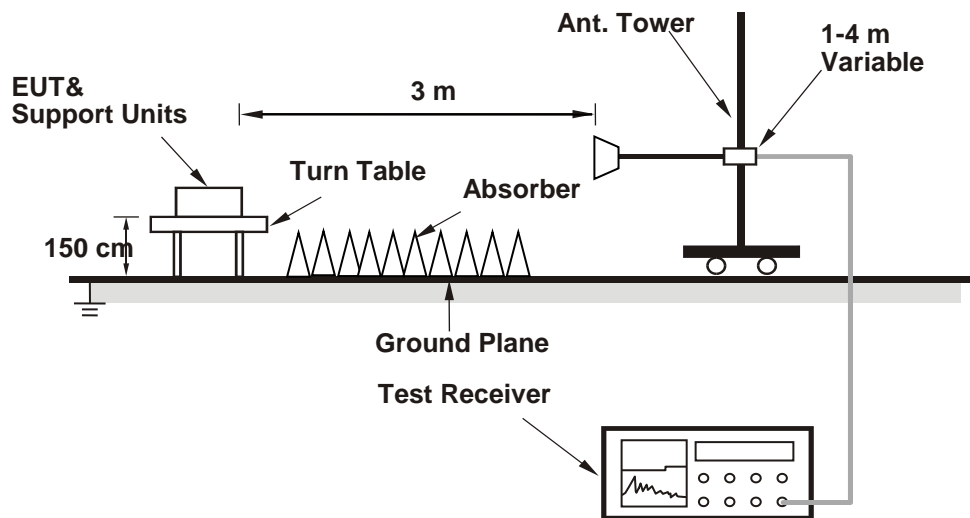

For the actual test configuration, please refer to the attached file (Test Setup Photo).

4.2.5 Test Results
Below 1GHz
WCDMA Band 2

Mode	TX channel 9400 (1880.0MHz)	Frequency Range	Below 1000 MHz
Environmental Conditions	23deg. C, 65%RH	Input Power	120Vac, 60Hz
Tested By	Raymond Lee		

Antenna Polarity & Test Distance: Horizontal at 3 M								
No	Frequency (MHz)	EIRP (dBm)	Limit (dBm)	Margin (dB)	Antenna Height (m)	Table Angle (Degree)	Raw Value (dBUV)	Correction Factor (dB/m)
1	88.20	-47.55	-13.00	-34.55	1.50 H	156	71.62	-119.17
2	174.53	-50.50	-13.00	-37.50	2.00 H	225	63.75	-114.25
3	253.10	-53.11	-13.00	-40.11	1.00 H	336	61.46	-114.57
4	400.54	-46.47	-13.00	-33.47	1.50 H	160	64.08	-110.55
5	777.87	-52.76	-13.00	-39.76	1.00 H	301	50.47	-103.23
6	959.26	-53.38	-13.00	-40.38	1.00 H	347	47.51	-100.89

Remarks:

1. $EIRP(dBm) = Raw\ Value(dBuV/m) + Correction\ Factor(dB/m)$
2. $Correction\ Factor(dB/m) = Antenna\ Factor(dB/m) + Cable\ Factor(dB) - Pre-Amplifier\ Factor(dB) + 20\log(D) - 104.8$
3. Margin value = EIRP – Limit value
4. The other EIRP levels were very low against the limit.

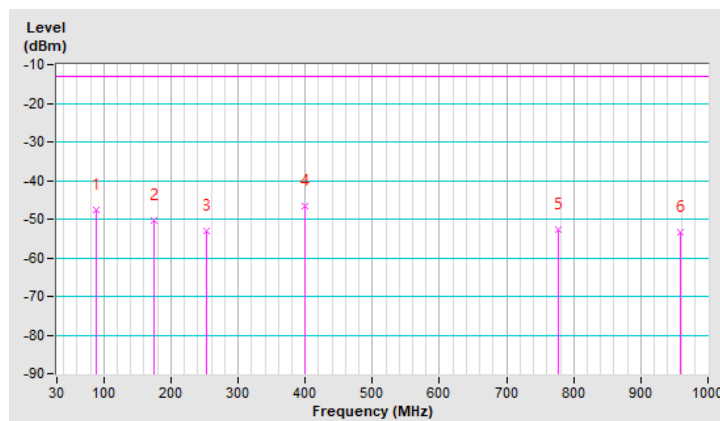

Mode	TX channel 9400 (1880.0MHz)	Frequency Range	Below 1000 MHz
Environmental Conditions	23deg. C, 65%RH	Input Power	120Vac, 60Hz
Tested By	Raymond Lee		

Antenna Polarity & Test Distance: Vertical at 3 M								
No	Frequency (MHz)	EIRP (dBm)	Limit (dBm)	Margin (dB)	Antenna Height (m)	Table Angle (Degree)	Raw Value (dBUV)	Correction Factor (dB/m)
1	54.25	-49.46	-13.00	-36.46	1.50 V	190	64.58	-114.04
2	84.32	-47.54	-13.00	-34.54	1.00 V	269	71.47	-119.01
3	171.62	-50.85	-13.00	-37.85	1.50 V	247	63.12	-113.97
4	642.07	-55.60	-13.00	-42.60	2.00 V	352	49.59	-105.19
5	773.02	-48.79	-13.00	-35.79	1.00 V	318	54.57	-103.36
6	956.35	-50.57	-13.00	-37.57	1.00 V	301	50.42	-100.99

Remarks:

1. $EIRP(dBm) = Raw\ Value(dBuV/m) + Correction\ Factor(dB/m)$
2. $Correction\ Factor(dB/m) = Antenna\ Factor(dB/m) + Cable\ Factor(dB) - Pre-Amplifier\ Factor(dB) + 20\log(D) - 104.8$
3. $Margin\ value = EIRP - Limit\ value$
4. The other EIRP levels were very low against the limit.

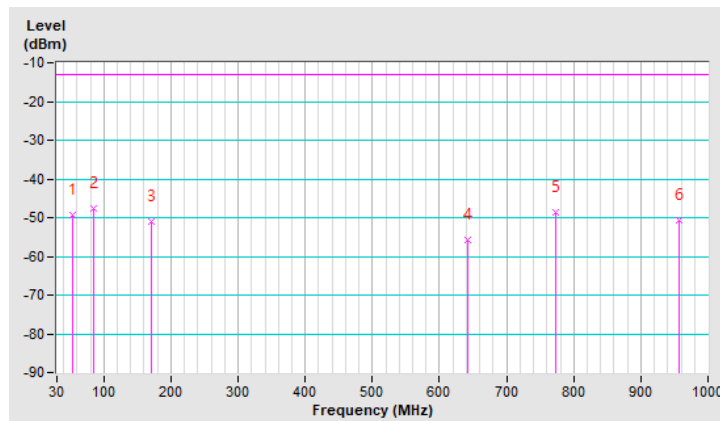

LTE Band 2, Channel Bandwidth: 3MHz

Mode	TX channel 18900 (1880.00MHz)	Frequency Range	Below 1000 MHz
Environmental Conditions	23deg. C, 65%RH	Input Power	120Vac, 60Hz
Tested By	Raymond Lee		

Antenna Polarity & Test Distance: Horizontal at 3 M

No	Frequency (MHz)	EIRP (dBm)	Limit (dBm)	Margin (dB)	Antenna Height (m)	Table Angle (Degree)	Raw Value (dBuV)	Correction Factor (dB/m)
1	88.20	-47.67	-13.00	-34.67	1.50 H	159	71.50	-119.17
2	174.53	-50.10	-13.00	-37.10	1.00 H	221	64.15	-114.25
3	251.16	-54.58	-13.00	-41.58	1.50 H	345	60.03	-114.61
4	770.11	-52.89	-13.00	-39.89	2.00 H	267	50.48	-103.37
5	891.36	-37.21	-13.00	-24.21	1.00 H	64	64.89	-102.10
6	956.35	-53.29	-13.00	-40.29	1.00 H	113	47.70	-100.99

Remarks:

1. $EIRP(dBm) = Raw\ Value(dBuV/m) + Correction\ Factor(dB/m)$
2. $Correction\ Factor(dB/m) = Antenna\ Factor(dB/m) + Cable\ Factor(dB) - Pre-Amplifier\ Factor(dB) + 20\log(D) - 104.8$
3. Margin value = EIRP – Limit value
4. The other EIRP levels were very low against the limit.

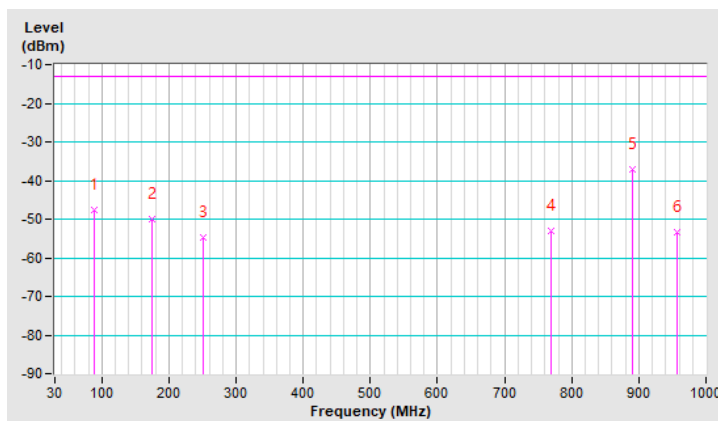

Mode	TX channel 18900 (1880.00MHz)	Frequency Range	Below 1000 MHz
Environmental Conditions	23deg. C, 65%RH	Input Power	120Vac, 60Hz
Tested By	Raymond Lee		

Antenna Polarity & Test Distance: Vertical at 3 M								
No	Frequency (MHz)	EIRP (dBm)	Limit (dBm)	Margin (dB)	Antenna Height (m)	Table Angle (Degree)	Raw Value (dBuV)	Correction Factor (dB/m)
1	54.25	-49.53	-13.00	-36.53	2.00 V	230	64.51	-114.04
2	84.32	-47.63	-13.00	-34.63	1.00 V	260	71.38	-119.01
3	170.65	-52.66	-13.00	-39.66	1.50 V	243	61.21	-113.87
4	771.08	-48.31	-13.00	-35.31	1.50 V	315	55.06	-103.37
5	892.33	-33.44	-13.00	-20.44	1.00 V	178	68.67	-102.11
6	957.32	-49.59	-13.00	-36.59	1.00 V	110	51.38	-100.97

Remarks:

1. $EIRP(dBm) = Raw\ Value(dBuV/m) + Correction\ Factor(dB/m)$
2. $Correction\ Factor(dB/m) = Antenna\ Factor(dB/m) + Cable\ Factor(dB) - Pre-Amplifier\ Factor(dB) + 20\log(D) - 104.8$
3. $Margin\ value = EIRP - Limit\ value$
4. The other EIRP levels were very low against the limit.

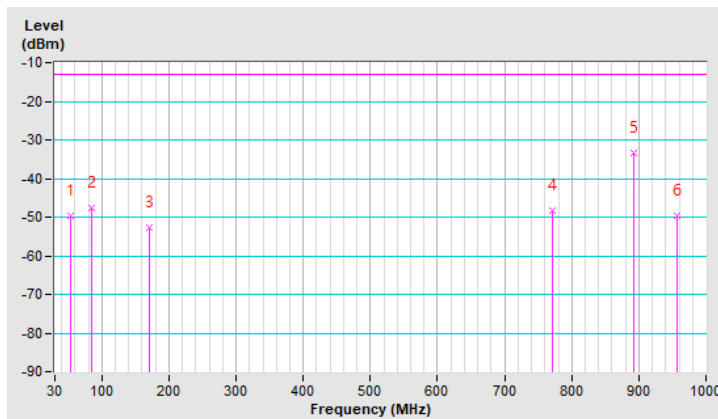

Above 1GHz
WCDMA Band 2

Mode	TX channel 9400 (1880.0MHz)	Frequency Range	1GHz ~ 20GHz
Environmental Conditions	23deg. C, 65%RH	Input Power	120Vac, 60Hz
Tested By	Greg Lin		

Antenna Polarity & Test Distance: Horizontal at 3 M								
No.	Frequency (MHz)	EIRP (dBm)	Limit (dBm)	Margin (dB)	Antenna Height (m)	Table Angle (Degree)	Raw Value (dBuV)	Correction Factor (dB/m)
1	3760.00	-45.53	-13.00	-32.53	2.63 H	328	49.39	-94.92
Antenna Polarity & Test Distance: Vertical at 3 M								
No.	Frequency (MHz)	EIRP (dBm)	Limit (dBm)	Margin (dB)	Antenna Height (m)	Table Angle (Degree)	Raw Value (dBuV)	Correction Factor (dB/m)
1	3760.00	-43.28	-13.00	-30.28	1.07 V	166	51.64	-94.92

Remarks:

1. $EIRP(dBm) = Raw\ Value(dBuV/m) + Correction\ Factor(dB/m)$
2. $Correction\ Factor(dB/m) = Antenna\ Factor(dB/m) + Cable\ Factor(dB) - Pre-Amplifier\ Factor(dB) + 20\log(D) - 104.8$
3. Margin value = EIRP – Limit value
4. The other EIRP levels were very low against the limit.

LTE Band 2, Channel Bandwidth 3MHz

Mode	TX channel 18900 (1880.00MHz)	Frequency Range	1GHz ~ 20GHz
Environmental Conditions	23deg. C, 65%RH	Input Power	120Vac, 60Hz
Tested By	Raymond Lee		

Antenna Polarity & Test Distance: Horizontal at 3 M								
No.	Frequency (MHz)	EIRP (dBm)	Limit (dBm)	Margin (dB)	Antenna Height (m)	Table Angle (Degree)	Raw Value (dBuV)	Correction Factor (dB/m)
1	3760.00	-43.20	-13.00	-30.20	2.74 H	332	51.72	-94.92
Antenna Polarity & Test Distance: Vertical at 3 M								
No.	Frequency (MHz)	EIRP (dBm)	Limit (dBm)	Margin (dB)	Antenna Height (m)	Table Angle (Degree)	Raw Value (dBuV)	Correction Factor (dB/m)
1	3760.00	-42.71	-13.00	-29.71	1.00 V	119	52.21	-94.92

Remarks:

1. $EIRP(dBm) = Raw\ Value(dBuV/m) + Correction\ Factor(dB/m)$
2. $Correction\ Factor(dB/m) = Antenna\ Factor(dB/m) + Cable\ Factor(dB) - Pre-Amplifier\ Factor(dB) + 20\log(D) - 104.8$
3. Margin value = EIRP – Limit value
4. The other EIRP levels were very low against the limit.

5 Pictures of Test Arrangements

Please refer to the attached file (Test Setup Photo).

Appendix – Information of the Testing Laboratories

We, Bureau Veritas Consumer Products Services (H.K.) Ltd., Taoyuan Branch, were founded in 1988 to provide our best service in EMC, Radio, Telecom and Safety consultation. Our laboratories are FCC recognized accredited test firms and accredited according to ISO/IEC 17025.

If you have any comments, please feel free to contact us at the following:

Lin Kou EMC/RF Lab

Tel: 886-2-26052180

Fax: 886-2-26051924

Hsin Chu EMC/RF/Telecom Lab

Tel: 886-3-6668565

Fax: 886-3-6668323

Hwa Ya EMC/RF/Safety Lab

Tel: 886-3-3183232

Fax: 886-3-3270892

Email: service.adt@tw.bureauveritas.com

Web Site: www.bureauveritas-adt.com

The address and road map of all our labs can be found in our web site also.

--- END ---