



TEST REPORT

Report Reference No...... : **TRE1605014401** R/C.....: 26610
FCC ID..... : **WIGLEYU1**
Applicant's name..... : **SHENZHEN EVERBEST MACHINERY INDUSTRY CO.,LTD**
Address..... : 19th Building, 5th Region, Baiwangxin Industrial Park,Songbai Rd.,
 Baimang, Xili,Nanshan, Shenzhen, China
Manufacturer..... : SHENZHEN EVERBEST MACHINERY INDUSTRY CO.,LTD
Address..... : 19th Building, 5th Region, Baiwangxin Industrial Park,Songbai Rd.,
 Baimang, Xili,Nanshan, Shenzhen, China
Test item description : **Non-Contact Forehead Infrared Thermometer**
Trade Mark : CEM
Model/Type reference..... : LEYU1
Listed Model(s)..... : LEYU2,LEYU3
Standard : **FCC CFR Title 47 Part 15 Subpart C Section 15.247**
Date of receipt of test sample..... : May.25, 2016
Date of testing..... : May.26, 2016- Jun.24,2016
Date of issue..... : Jun.27,2016
Result..... : **PASS**

Compiled by
 (position+printedname+signature)....: File administrators Candy Liu

Candy Liu

Supervised by
 (position+printedname+signature)....: Project Engineer Jeff Sun

Jeff Sun

Approved by
 (position+printedname+signature)....: RF Manager Hans Hu

Hans Hu

Testing Laboratory Name : **Shenzhen Huatongwei International Inspection Co., Ltd.**
Address..... : 1/F, Bldg 3, Hongfa Hi-tech Industrial Park, Genyu Road, Tianliao,
 Gongming, Shenzhen, China

Shenzhen Huatongwei International Inspection Co., Ltd. All rights reserved.

This publication may be reproduced in whole or in part for non-commercial purposes as long as the Shenzhen Huatongwei International Inspection Co., Ltd is acknowledged as copyright owner and source of the material. Shenzhen Huatongwei International Inspection Co., Ltd takes no responsibility for and will not assume liability for damages resulting from the reader's interpretation of the reproduced material due to its placement and context.

Contents

1.	<u>APPLICABLE STANDARDS AND TEST DESCRIPTION</u>	3
1.1.	Applicable Standards	3
1.2.	Test Description	3
2.	<u>SUMMARY</u>	4
2.1.	Client Information	4
2.2.	Product Description	4
2.3.	Operation state	5
2.4.	EUT configuration	5
2.5.	Modifications	5
3.	<u>TEST ENVIRONMENT</u>	6
3.1.	Address of the test laboratory	6
3.2.	Test Facility	6
3.3.	Equipments Used during the Test	7
3.4.	Environmental conditions	8
3.5.	Statement of the measurement uncertainty	8
4.	<u>TEST CONDITIONS AND RESULTS</u>	9
4.1.	Antenna requirement	9
4.2.	Conducted Emission (AC Main)	10
4.3.	Conducted Peak Output Power	11
4.4.	Power Spectral Density	12
4.5.	6dB bandwidth	14
4.6.	Restricted band	16
4.7.	Band edge and Spurious Emission (conducted)	19
4.8.	Spurious Emission (radiated)	23
5.	<u>TEST SETUP PHOTOS OF THE EUT</u>	31
6.	<u>EXTERNAL AND INTERNAL PHOTOS OF THE EUT</u>	32

1. APPLICABLE STANDARDS AND TEST DESCRIPTION

1.1. Applicable Standards

The tests were performed according to following standards:

[FCC Rules Part 15.247](#): Frequency Hopping, Direct Spread Spectrum and Hybrid Systems that are in operation within the bands of 902-928 MHz, 2400-2483.5 MHz, and 5725-5850 MHz.

[ANSI C63.10-2013](#): American National Standard for Testing Unlicensed Wireless Devices

[KDB 558074 D01 DTS Meas Guidance v03r05](#): Guidance for Performing Compliance Measurements on Digital Transmission Systems (DTS) Operating under § 15.247

1.2. Test Description

Test Item	Section in CFR 47	Result
Antenna requirement	15.203/15.247 (c)	Pass
Line Conducted Emission (AC Main)	15.207	N/A
Conducted Peak Output Power	15.247 (b)(3)	Pass
Power Spectral Density	15.247 (e)	Pass
6dB Bandwidth	15.247 (a)(2)	Pass
Restricted band	15.247(d)/15.205	Pass
Spurious Emission	15.247(d)/15.209	Pass

Remark: The measurement uncertainty is not included in the test result.

2. SUMMARY

2.1. Client Information

Applicant:	SHENZHEN EVERBEST MACHINERY INDUSTRY CO.,LTD
Address:	19th Building, 5th Region, Baiwangxin Industrial Park,Songbai Rd., Baimang, Xili,Nanshan, Shenzhen, China
Manufacturer:	SHENZHEN EVERBEST MACHINERY INDUSTRY CO.,LTD
Address:	19th Building, 5th Region, Baiwangxin Industrial Park,Songbai Rd., Baimang, Xili,Nanshan, Shenzhen, China

2.2. Product Description

Name of EUT	Non-Contact Forehead Infrared Thermometer
Trade Mark:	CEM
Model No.:	LEYU1
Listed Model(s):	LEYU2,LEYU3
Power supply:	DC 3.0V for internal battery
Adapter information:	-
Hardware version:	Leyu_4.0
Software version:	V3.0
Bluetooth	
Version:	Supported BT4.0+BLE
Modulation:	GFSK
Operation frequency:	2402MHz - 2480MHz
Channel number:	40
Channel separation:	2 MHz
Antenna type:	Internal Antenna
Antenna gain:	0dBi

2.3. Operation state

◆ Test frequency list

According to section 15.31(m), regards to the operating frequency range over 10 MHz, must select three channel which were tested. the Lowest frequency, the middle frequency, and the highest frequency of channel were selected to perform the test, please see the above gray bottom.

Channel	Frequency (MHz)
00	2402
01	2404
02	2408
...	...
19	2440
...	...
37	2476
38	2478
39	2480

◆ Test mode

For RF test items:

The engineering test program was provided and enabled to make EUT continuous transmit/receive.

2.4. EUT configuration

The following peripheral devices and interface cables were connected during the measurement:

- - supplied by the manufacturer
- - supplied by the lab

<input type="radio"/>	PowerCable	Length (m) :	/
		Shield :	/
		Detachable :	/
<input type="radio"/>	Multimeter	Manufacturer :	/
		Model No. :	/

2.5. Modifications

No modifications were implemented to meet testing criteria.

3. TEST ENVIRONMENT

3.1. Address of the test laboratory

Laboratory: Shenzhen Huatongwei International Inspection Co., Ltd.

Address: 1/F, Bldg 3, Hongfa Hi-tech Industrial Park, Genyu Road, Tianliao, Gongming, Shenzhen, China

Phone: 86-755-26748019 Fax: 86-755-26748089

3.2. Test Facility

The test facility is recognized, certified, or accredited by the following organizations:

CNAS-Lab Code: L1225

Shenzhen Huatongwei International Inspection Co., Ltd. has been assessed and proved to be in compliance with CNAS-CL01 Accreditation Criteria for Testing and Calibration Laboratories

(identical to ISO/IEC17025: 2005 General Requirements) for the Competence of Testing and Calibration Laboratories, Date of Registration: February 28, 2015. Valid time is until February 27, 2018.

A2LA-Lab Cert. No. 3902.01

Shenzhen Huatongwei International Inspection Co., Ltd. EMC Laboratory has been accredited by A2LA for technical competence in the field of electrical testing, and proved to be in compliance with ISO/IEC 17025: 2005 General Requirements for the Competence of Testing and Calibration Laboratories and any additional program requirements in the identified field of testing. Valid time is until December 31, 2016.

FCC-Registration No.: 317478

Shenzhen Huatongwei International Inspection Co., Ltd. EMC Laboratory has been registered and fully described in a report filed with the FCC (Federal Communications Commission). The acceptance letter from the FCC is maintained in our files. Registration 317478, Renewal date Jul. 18, 2014, valid time is until Jul. 18, 2017.

IC-Registration No.: 5377A&5377B

The 3m Alternate Test Site of Shenzhen Huatongwei International Inspection Co., Ltd. has been registered by Certification and Engineering Bureau of Industry Canada for the performance of radiated measurements with Registration No. 5377A on Dec. 31, 2013, valid time is until Dec. 31, 2016.

Two 3m Alternate Test Site of Shenzhen Huatongwei International Inspection Co., Ltd. has been registered by Certification and Engineering Bureau of Industry Canada for the performance of radiated measurements with Registration No. 5377B on Dec.03, 2014, valid time is until Dec.03, 2017.

ACA

Shenzhen Huatongwei International Inspection Co., Ltd. EMC Laboratory can also perform testing for the Australian C-Tick mark as a result of our A2LA accreditation.

VCCI

Radiated disturbance above 1GHz measurement of Shenzhen Huatongwei International Inspection Co., Ltd. has been registered in accordance with the Regulations for Voluntary Control Measures with Registration No.: G-292. Date of Registration: Dec. 24, 2013. Valid time is until Dec. 23, 2016.

Telecommunication Ports Conducted Interference Measurement of Shenzhen Huatongwei International Inspection Co., Ltd. has been registered in accordance with the Regulations for Voluntary Control Measures with Registration No.: T-1837. Date of Registration: May 07, 2013. Valid time is until May 06, 2016.

DNV

Shenzhen Huatongwei International Inspection Co., Ltd. has been found to comply with the requirements of DNV towards subcontractor of EMC and safety testing services in conjunction with the EMC and Low voltage Directives and in the voluntary field. The acceptance is based on a formal quality Audit and follow-ups according to relevant parts of ISO/IEC Guide 17025 (2005), in accordance with the requirements of the DNV Laboratory Quality Manual towards subcontractors. Valid time is until Aug. 24, 2016.

3.3. Equipments Used during the Test

Maximum Peak Output Power / Power Spectral Density / 6dB Bandwidth / Band Edge Compliance of RF Emission / Spurious RF Conducted Emission					
Item	Test Equipment	Manufacturer	Model No.	Serial No.	Last Cal
1	Spectrum Analyzer	Rohde&Schwarz	FSP	1164.4391.40	2015/11/02
2	Climate Chamber	ESPEC	EL-10KA	05107008	2015/11/02
3	Test cable	Junkosha Inc.	J12J102248	JUL-06-14-016	2015/12/05
4	Temporary antenna connector	/	/	/	/

NOTE: The temporary antenna connector is soldered on the PCB board in order to perform conducted tests and this temporary antenna connector is listed in the equipment list.

Radiated Emission					
Item	Test Equipment	Manufacturer	Model No.	Serial No.	Last Cal.
1	EMI TEST RECEIVER	Rohde&Schwarz	ESI 26	100009	2015/11/02
2	RF TEST PANEL	Rohde&Schwarz	TS / RSP	335015/ 0017	N/A
3	EMI TEST SOFTWARE	Rohde&Schwarz	ESK1	N/A	N/A
4	Loop Antenna	Rohde&Schwarz	HZ-9	838622\013	2015/11/08
5	Ultra-Broadband Antenna	ShwarzBeck	VULB9163	538	2015/11/08
6	HORN ANTENNA	ShwarzBeck	9120D	1011	2015/11/08
7	Broadband Horn Antenna	ShwarzBeck	BBHA 9170	BBHA917047 2	2015/11/08
8	Pre-amplifer	SCHWARZBECK	BBV 9743	9743-0022	2015/11/02
9	TURNTABLE	MATURO	TT2.0	----	N/A
10	ANTENNA MAST	MATURO	TAM-4.0-P	----	N/A
11	EMI TEST SOFTWARE	Audix	E3	N/A	N/A
12	Test cable	Siva Cables Italy	RG 58A/U	W14.02	2015/12/05

The Cal.Interval was one year

3.4. Environmental conditions

During the measurement the environmental conditions were within the listed ranges:

Temperature:	15~35°C
Relative Humidity:	30~60 %
Air Pressure:	950~1050mba

3.5. Statement of the measurement uncertainty

The data and results referenced in this document are true and accurate. The reader is cautioned that there may be errors within the calibration limits of the equipment and facilities. The measurement uncertainty was calculated for all measurements listed in this test report according to TR-100028-01 "Electromagnetic compatibility and Radio spectrum Matters (ERM); Uncertainties in the measurement of mobile radio equipment characteristics; Part 1" and TR-100028-02 "Electromagnetic compatibility and Radio spectrum Matters (ERM); Uncertainties in the measurement of mobile radio equipment characteristics; Part 2" and is documented in the Shenzhen Huatongwei International Inspection Co., Ltd quality system according to DIN EN ISO/IEC 17025. Furthermore, component and process variability of devices similar to that tested may result in additional deviation. The manufacturer has the sole responsibility of continued compliance of the device.

Hereafter the best measurement capability for Shenzhen Huatongwei laboratory is reported:

Test Items	Measurement Uncertainty	Notes
Transmitter power conducted	0.57 dB	(1)
Transmitter power Radiated	2.20 dB	(1)
Conducted spurious emission 9KHz-40 GHz	1.60 dB	(1)
Radiated spurious emission 9KHz-40 GHz	2.20 dB	(1)
Conducted Emission 9KHz-30MHz	3.39 dB	(1)
Radiated Emission 30~1000MHz	4.24 dB	(1)
Radiated Emission 1~18GHz	5.16 dB	(1)
Radiated Emission 18-40GHz	5.54 dB	(1)
Occupied Bandwidth	-----	(1)

(1) This uncertainty represents an expanded uncertainty expressed at approximately the 95% confidence level using a coverage factor of $k=1.96$.

4.2. Conducted Emission (AC Main)

LIMIT

FCC CFR Title 47 Part 15 Subpart C Section 15.207:

Frequency range (MHz)	Limit (dBuV)	
	Quasi-peak	Average
0.15-0.5	66 to 56*	56 to 46*
0.5-5	56	46
5-30	60	50

* Decreases with the logarithm of the frequency.

TEST CONFIGURATION

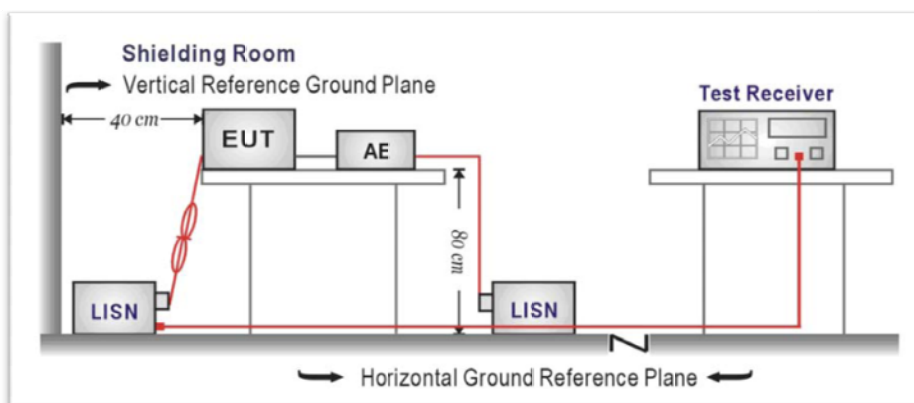

TEST PROCEDURE

1. The EUT was setup according to ANSI C63.10:2013 for compliance to FCC 47CFR 15.247 requirements.
2. The EUT was placed on a platform of nominal size, 1 m by 1.5 m, raised 80 cm above the conducting ground plane. The vertical conducting plane was located 40 cm to the rear of the EUT. All other surfaces of EUT were at least 80 cm from any other grounded conducting surface.
3. The EUT and simulators are connected to the main power through a line impedance stabilization network (LISN). The LISN provides a 50 ohm /50uH coupling impedance for the measuring equipment.
4. The peripheral devices are also connected to the main power through a LISN. (Please refer to the block diagram of the test setup and photographs)
5. Each current-carrying conductor of the EUT power cord, except the ground (safety) conductor, was individually connected through a LISN to the input power source.
6. The excess length of the power cord between the EUT and the LISN receptacle were folded back and forth at the center of the lead to form a bundle not exceeding 40 cm in length.
7. Conducted emissions were investigated over the frequency range from 0.15 MHz to 30 MHz using a receiver bandwidth of 9 kHz.
8. During the above scans, the emissions were maximized by cable manipulation.

TEST RESULTS

Test item is not applicable for EUT.

4.3. Conducted Peak Output Power

LIMIT

FCC CFR Title 47 Part 15 Subpart C Section 15.247 (b)(3): **30dBm**:

TEST CONFIGURATION

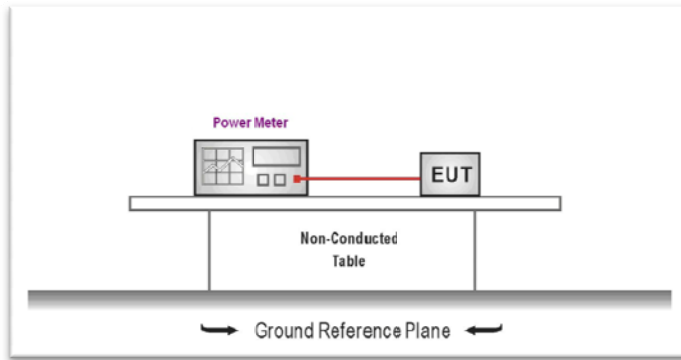

TEST PROCEDURE

1. The EUT was tested according to ANSI C63.10: 2013 and KDB 558074 D01 V03R04 for compliance to FCC 47CFR 15.247 requirements.
2. The maximum peak conducted output power may be measured using a broadband peak RF power meter.
3. The power meter shall have a video bandwidth that is greater than or equal to the DTS bandwidth and shall utilize a fast-responding diode detector
4. Record the measurement data.

TEST RESULTS

Type	Channel	Output power (dBm)	Limit (dBm)	Result
BLE	00	-7.20	30.00	Pass
	19	-7.23		
	39	-6.93		

4.4. Power Spectral Density

LIMIT

FCC CFR Title 47 Part 15 Subpart C Section 15.247 (e):

For digitally modulated systems, the power spectral density conducted from the intentional radiator to the antenna shall not be greater than 8 dBm in any 3 kHz band during any time interval of continuous transmission.

TEST CONFIGURATION

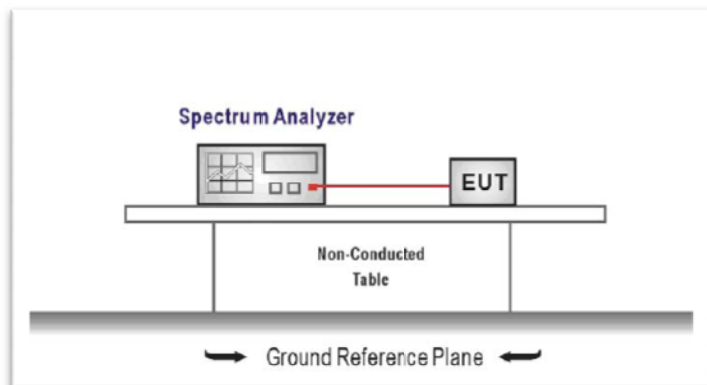

TEST PROCEDURE

1. Connect the antenna port(s) to the spectrum analyzer input,
2. Configure the spectrum analyzer as shown below:
Center frequency=DTS channel center frequency
Span =1.5 times the DTS bandwidth
RBW = 3 kHz ≤ RBW ≤ 100 kHz, VBW ≥ 3 × RBW
Sweep time = auto couple
Detector = peak
Trace mode = max hold
3. Place the radio in continuous transmit mode, allow the trace to stabilize, view the transmitter waveform on the spectrum analyzer.
4. Use the peak marker function to determine the maximum amplitude level within the RBW.
5. If measured value exceeds limit, reduce RBW (no less than 3 kHz) and repeat.

TEST RESULTS

Type	Channel	Power Spectral Density(dBm/3KHz)	Limit (dBm/3KHz)	Result
BLE	00	-13.65	8.00	Pass
	19	-13.64		
	39	-13.69		

Test plot as follows:

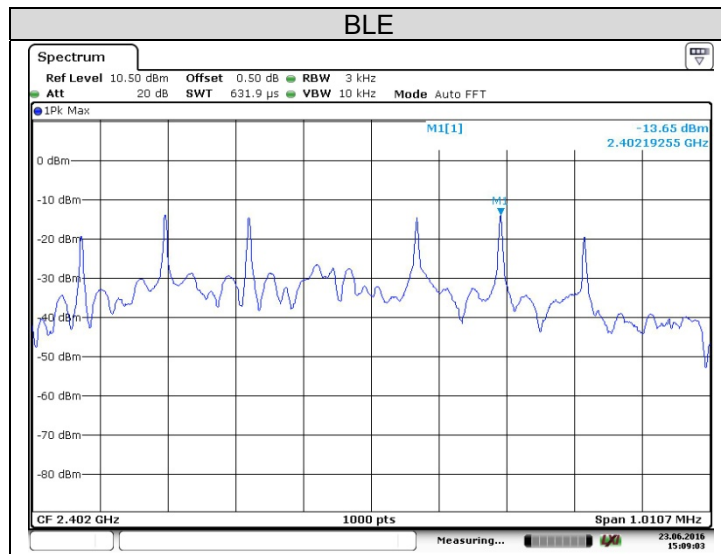

CH00

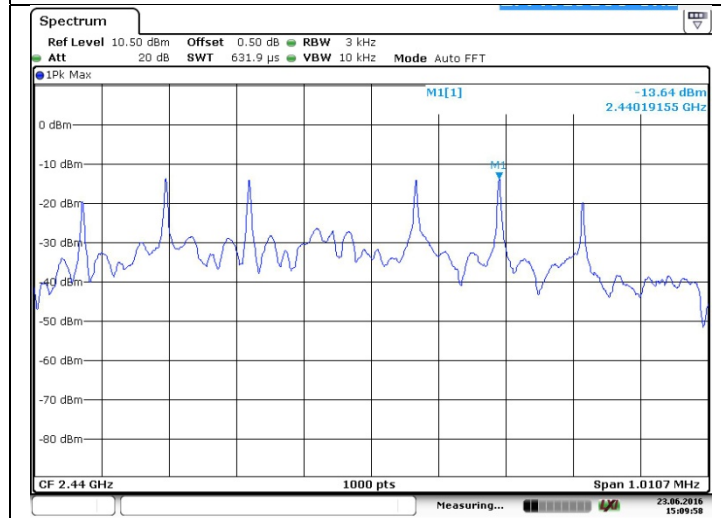

CH19

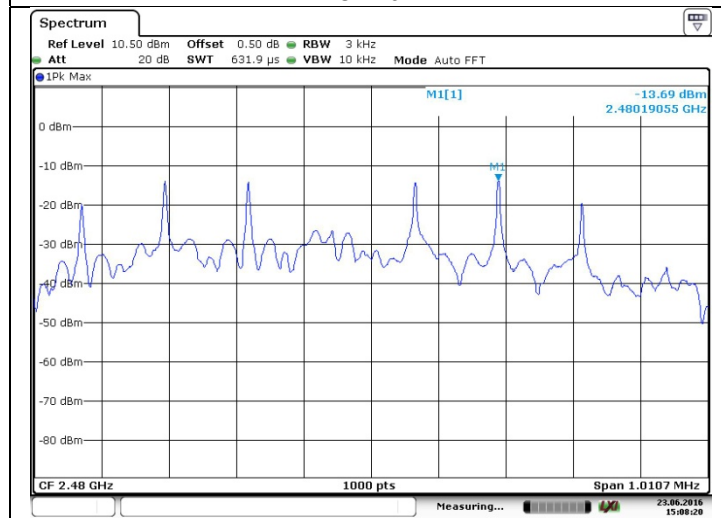

CH39

4.5. 6dB bandwidth

LIMIT

FCC CFR Title 47 Part 15 Subpart C Section 15.247 (a)(2):

For digital modulation systems, the minimum 6 dB bandwidth shall be at least 500 kHz.

TEST CONFIGURATION

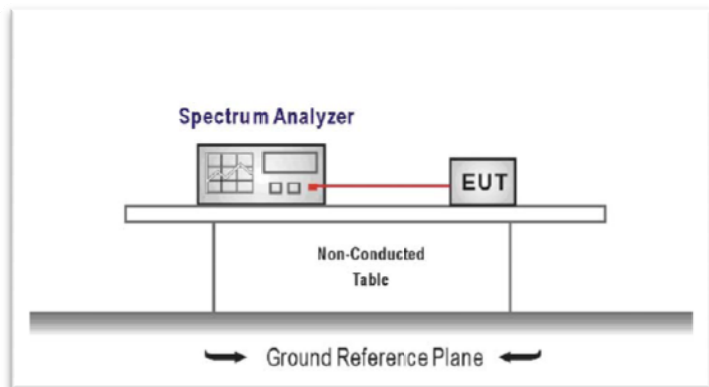

TEST PROCEDURE

1. Connect the antenna port(s) to the spectrum analyzer input.
2. Configure the spectrum analyzer as shown below (enter all losses between the transmitter output and the spectrum analyzer).
Center Frequency = DTS channel center frequency
Span = 2 x DTS bandwidth
RBW = 100 kHz, VBW ≥ 3 x RBW
Sweep time = auto couple
Detector = Peak
Trace mode = max hold
3. Place the radio in continuous transmit mode, allow the trace to stabilize, view the transmitter waveform on the spectrum analyzer.
4. Measure the maximum width of the emission that is constrained by the frequencies associated with the two outermost amplitude points (upper and lower frequencies) that are attenuated by 6 dB relative to the maximum level measured in the fundamental emission, and record the pertinent measurements.

TEST RESULTS

Type	Channel	6dB Bandwidth (KHz)	Limit (KHz)	Result
BLE	00	673.800	≥500	Pass
	19	671.164		
	39	663.650		

Test plot as follows:

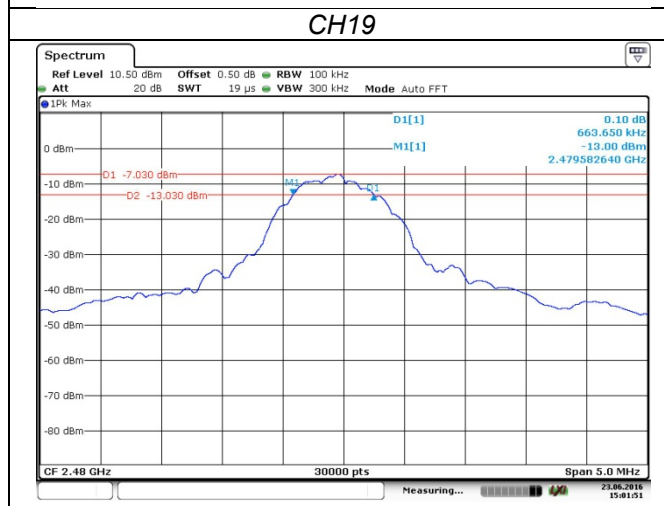
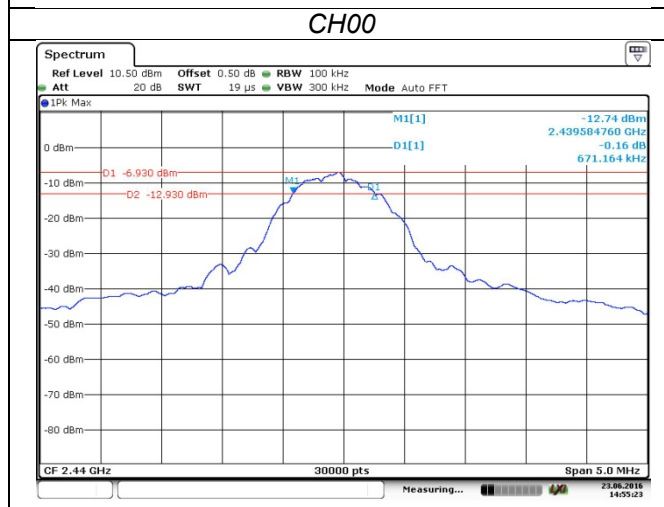
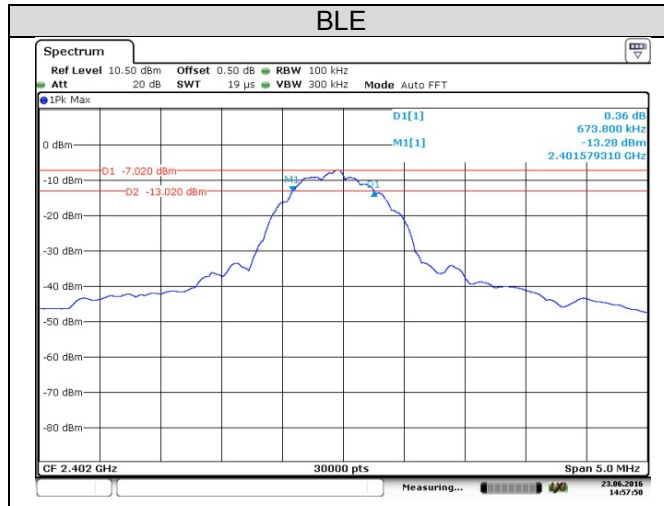

CH39

4.6. Restricted band

LIMIT

FCC CFR Title 47 Part 15 Subpart C Section 15.247 (d)::

In any 100 kHz bandwidth outside the frequency band in which the spread spectrum or digitally modulated intentional radiator is operating, radiated emissions which fall in the restricted bands, as defined in §15.205(a), must also comply with the radiated emission limits specified in §15.209(a) (see §15.205(c)).

TEST CONFIGURATION

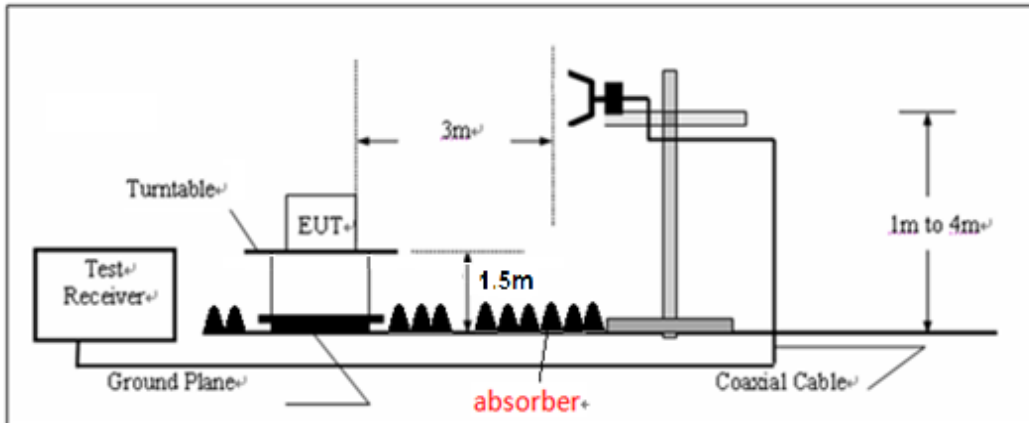

TEST PROCEDURE

1. The EUT was setup and tested according to ANSI C63.10:2013 for compliance to FCC 47CFR 15.247 requirements.
2. The EUT is placed on a turn table which is 1.5 meter above ground. The turn table is rotated 360 degrees to determine the position of the maximum emission level.
3. The EUT was positioned such that the distance from antenna to the EUT was 3 meters.
4. The antenna is scanned from 1 meter to 4 meters to find out the maximum emission level. This is repeated for both horizontal and vertical polarization of the antenna. In order to find the maximum emission, all of the interface cables were manipulated according to ANSI C63.10:2013 on radiated measurement.
5. The receiver set as follow:
RBW=1MHz, VBW=3MHz for Peak value
RBW=1MHz, VBW=3MHz for Average value.

TEST RESULTS

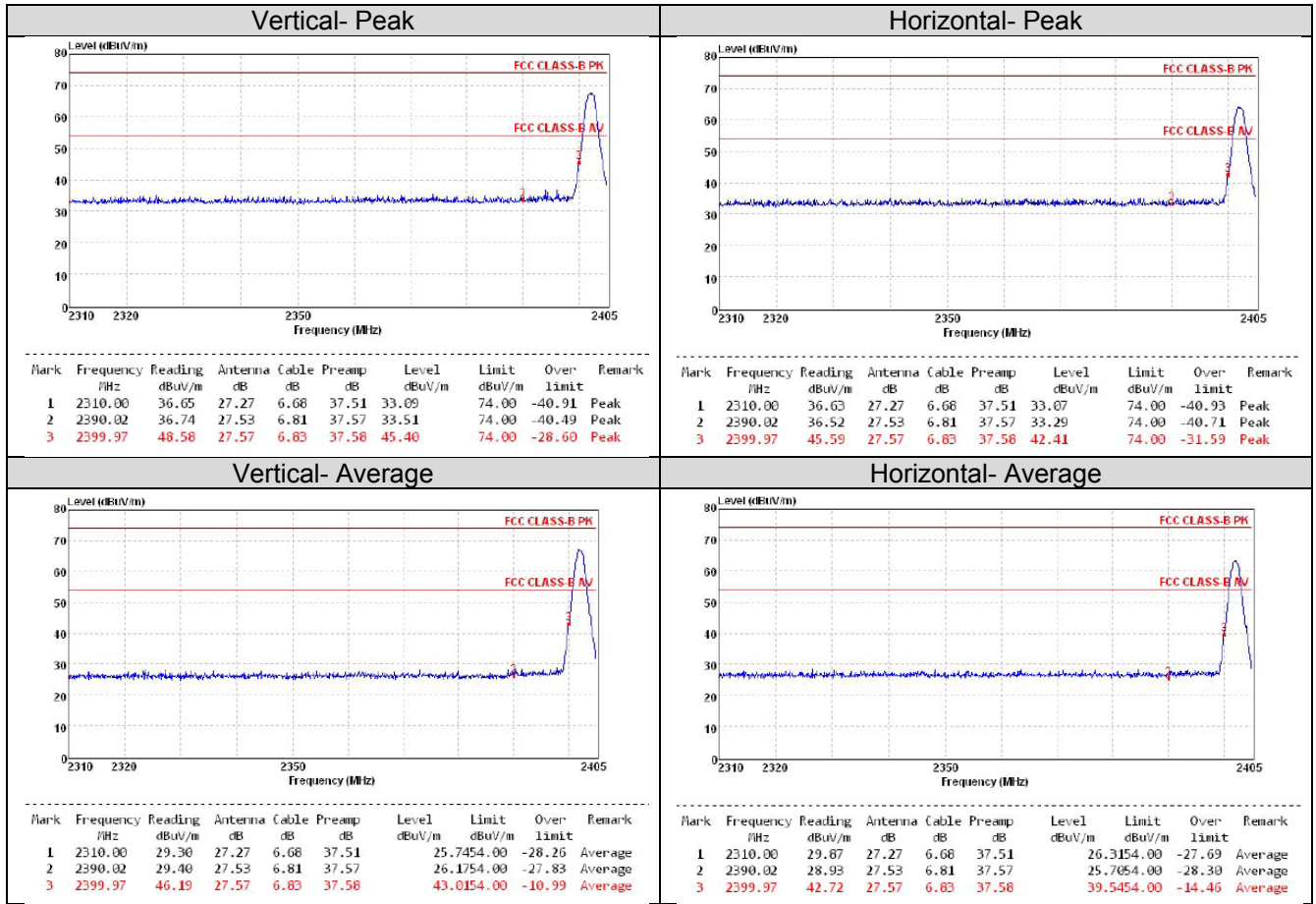

Note: Level = Read + Antenna Factor + Cable Loss - Preamp Factor

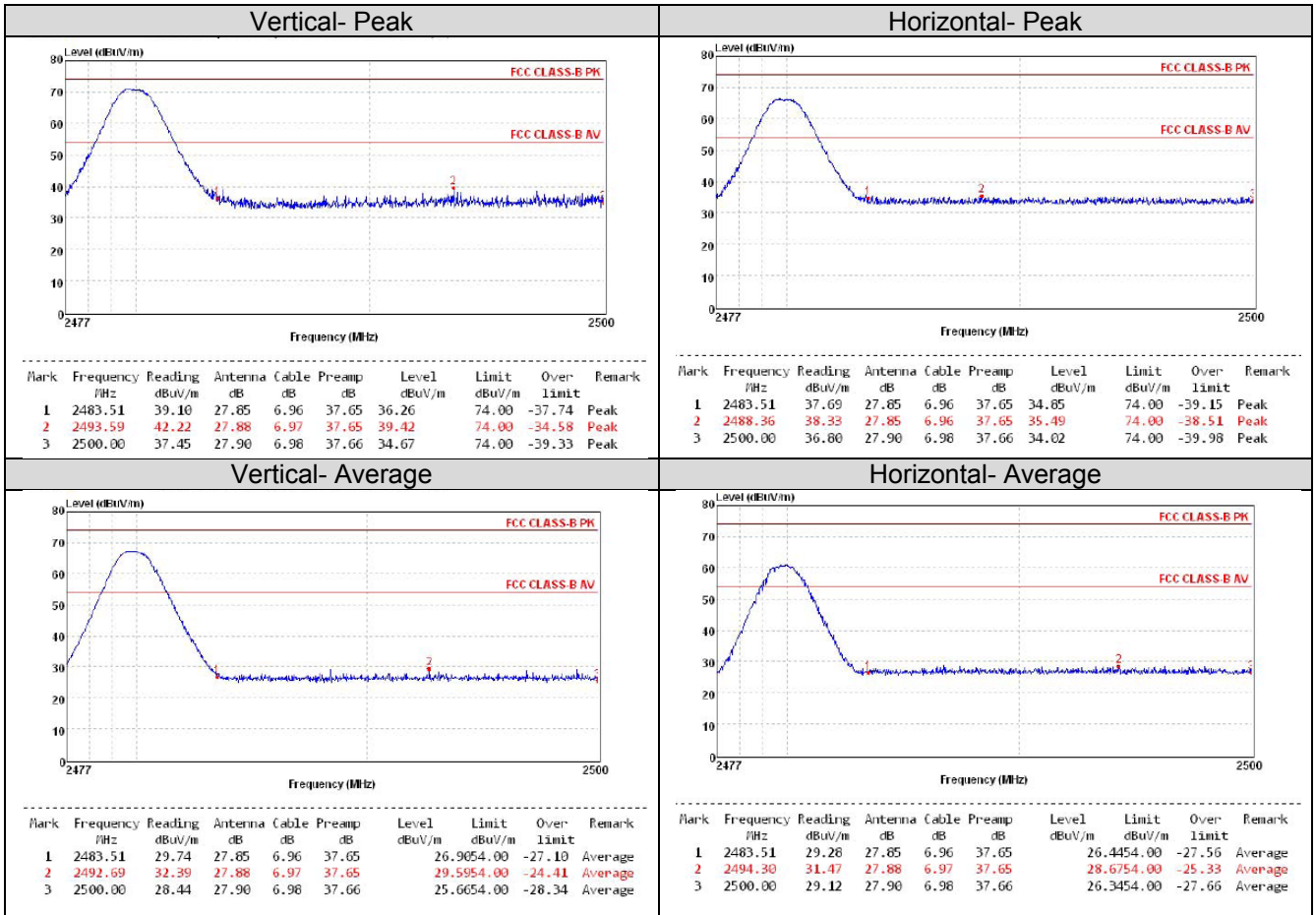

Note: Level= Read+ Antenna Factor+ Cable Loss- Preamp Factor

4.7. Band edge and Spurious Emission (conducted)

LIMIT

FCC CFR Title 47 Part 15 Subpart C Section 15.247 (d):

In any 100 kHz bandwidth outside the frequency band in which the spread spectrum intentional radiator is operating, the radio frequency power that is produced by the intentional radiator shall be at least 20 dB below that in the 100 kHz bandwidth within the band that contains the highest level of the desired power, based on either an RF conducted or a radiated measurement.

TEST CONFIGURATION

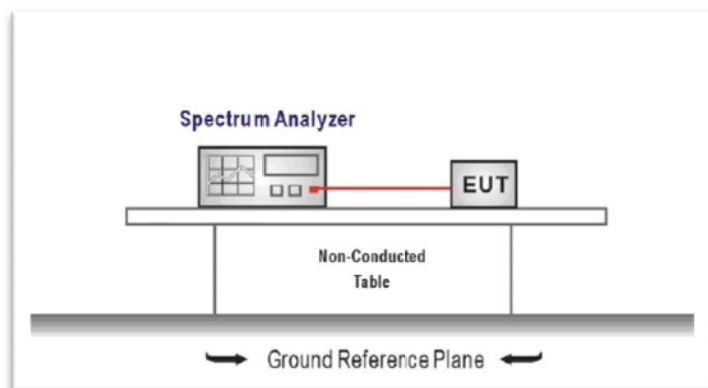

TEST PROCEDURE

1. Connect the antenna port(s) to the spectrum analyzer input.
2. **Establish a reference level by using the following procedure**
Center frequency=DTS channel center frequency
The span = 1.5 times the DTS bandwidth.
RBW = 100 kHz, VBW ≥ 3 x RBW
Detector = peak, Sweep time = auto couple, Trace mode = max hold
Allow trace to fully stabilize
Use the peak marker function to determine the maximum PSD level

Note that the channel found to contain the maximum PSD level can be used to establish the reference level.

3. **Emission level measurement**
Set the center frequency and span to encompass frequency range to be measured
RBW = 100 kHz, VBW ≥ 3 x RBW
Detector = peak, Sweep time = auto couple, Trace mode = max hold
Allow trace to fully stabilize
Use the peak marker function to determine the maximum amplitude level.
4. Place the radio in continuous transmit mode, allow the trace to stabilize, view the transmitter waveform on the spectrum analyzer.
5. Ensure that the amplitude of all unwanted emissions outside of the authorized frequency band excluding restricted frequency bands) are attenuated by at least the minimum requirements specified (at least 20 dB relative to the maximum in-band peak PSD level in 100 kHz). Report the three highest emissions relative to the limit.

TEST RESULTS

Test plot as follows:

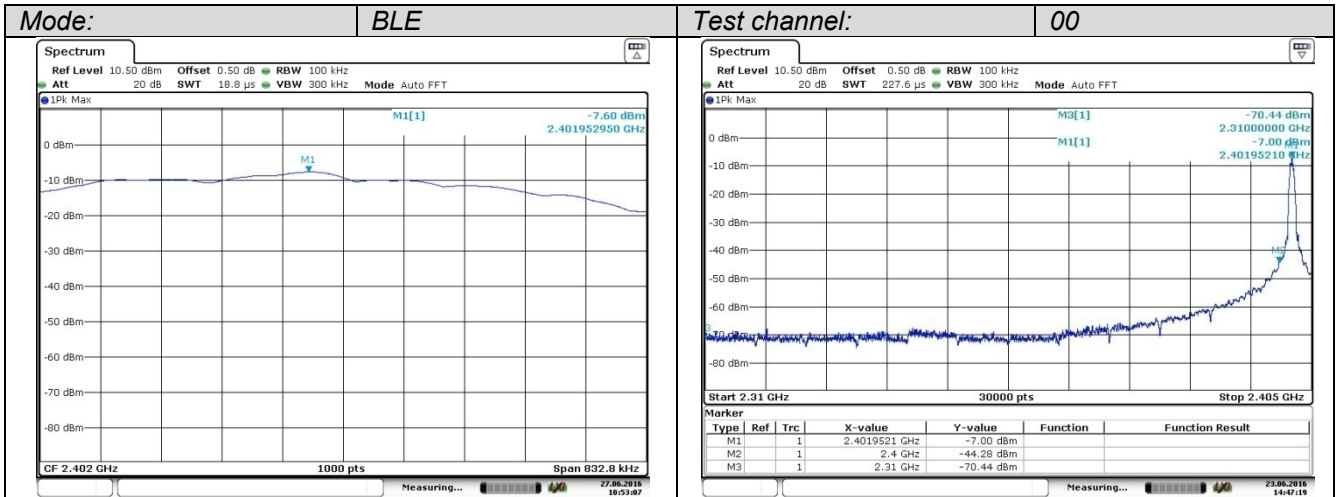

100KHz PSD Reference Level

Low bandedge Plot

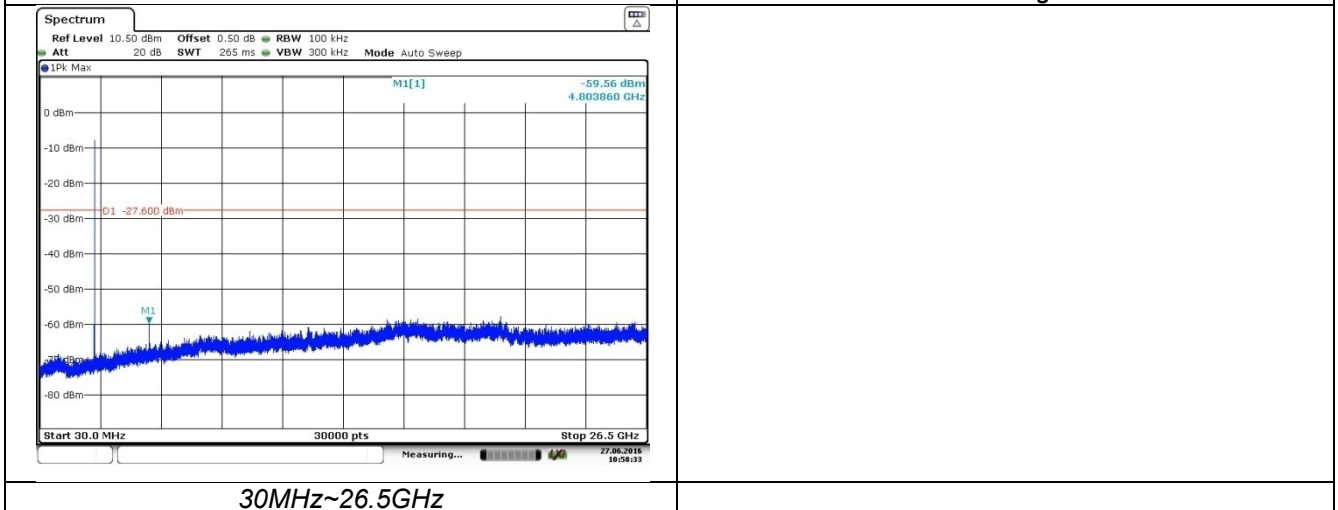

30MHz~26.5GHz

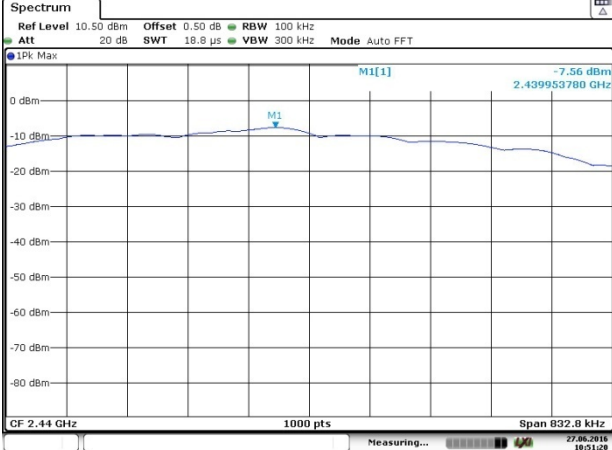
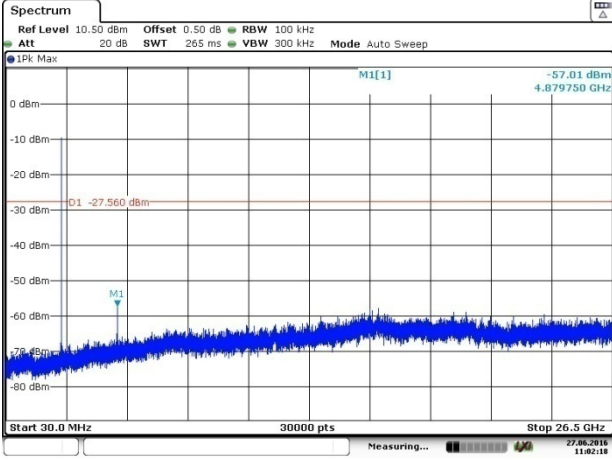
Mode:	BLE	Test channel:	19
			
100KHz PSD Reference Level			
			
30MHz~26.5GHz			

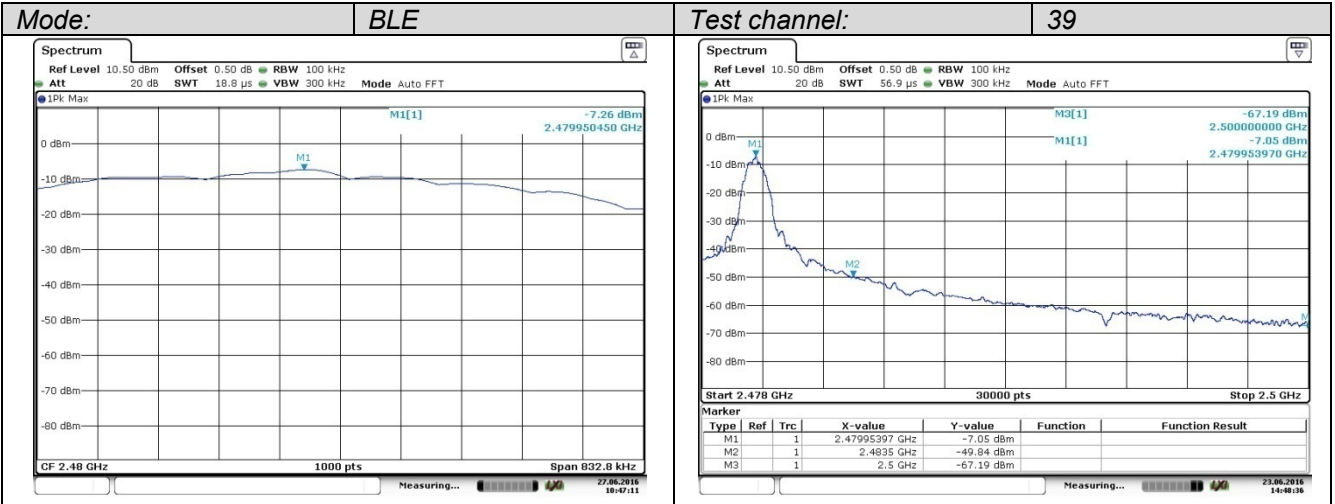

100KHz PSD Reference Level

High bandedge Plot

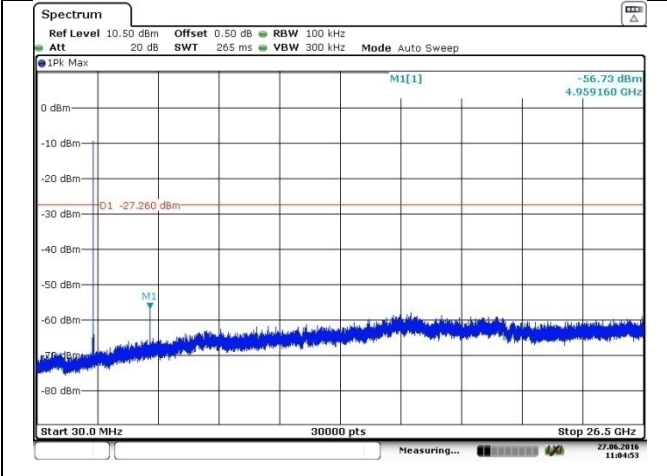

30MHz~3GHz



4.8. Spurious Emission (radiated)

LIMIT

FCC CFR Title 47 Part 15 Subpart C Section 15.209

Frequency	Limit (dBuV/m @3m)	Value
30MHz-88MHz	40.00	Quasi-peak
88MHz-216MHz	43.50	Quasi-peak
216MHz-960MHz	46.00	Quasi-peak
960MHz-1GHz	54.00	Quasi-peak
Above 1GHz	54.00	Average
	74.00	Peak

TEST CONFIGURATION

- 9KHz ~30MHz

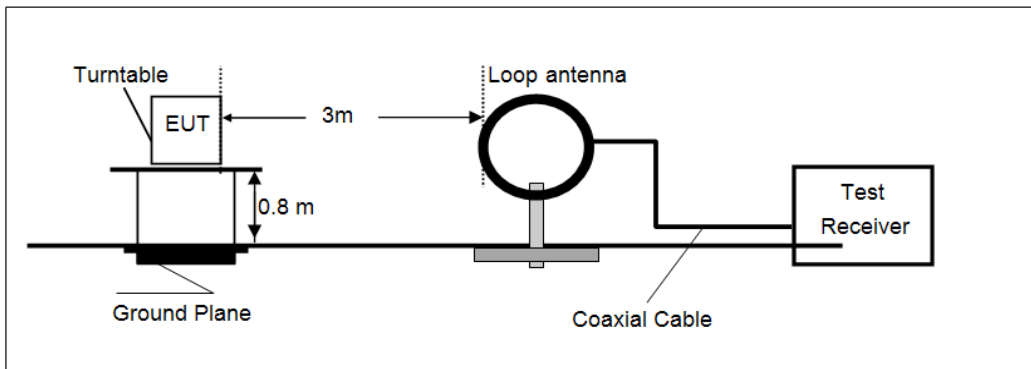

- 30MHz ~ 1GHz

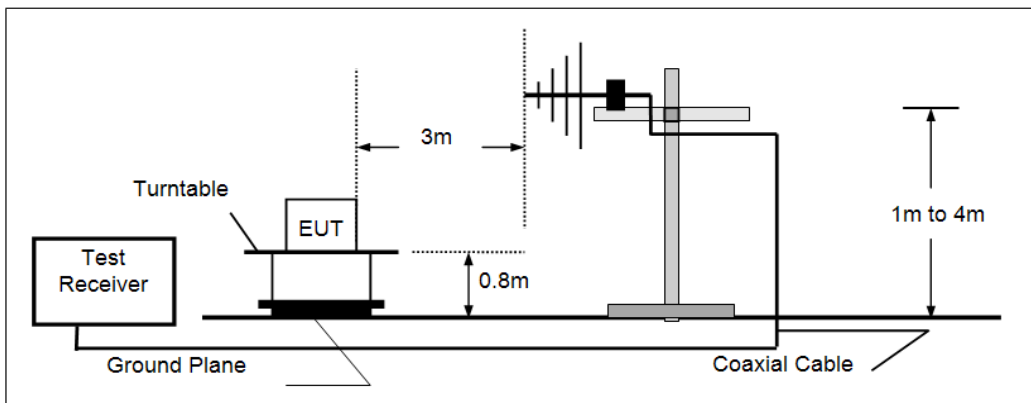

- Above 1GHz

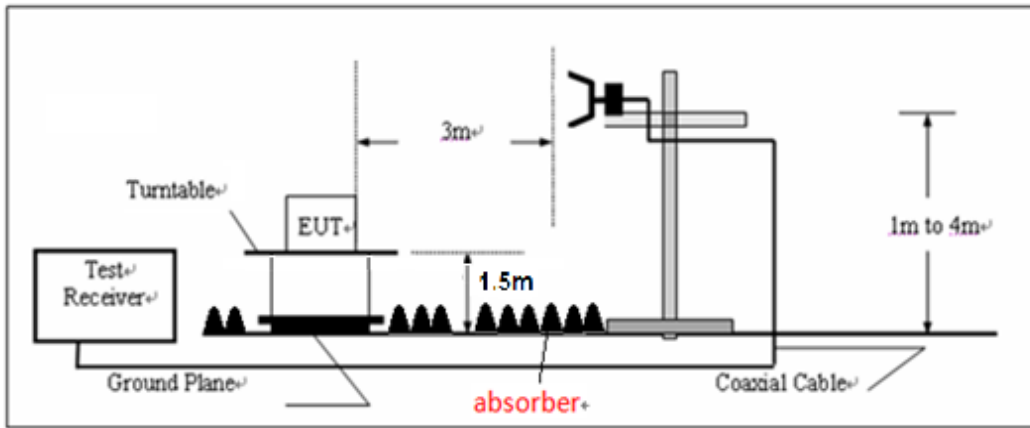

TEST PROCEDURE

1. The EUT was tested according to ANSI C63.10:2013 for compliance to FCC 47CFR 15.247 requirements.
2. The EUT is placed on a turn table which is 0.8 meter above ground. The turn table is rotated 360 degrees to determine the position of the maximum emission level.
3. The EUT was positioned such that the distance from antenna to the EUT was 3 meters.
4. The antenna is scanned from 1 meter to 4 meters to find out the maximum emission level. This is repeated for both horizontal and vertical polarization of the antenna.
5. Use the following spectrum analyzer settings
 - (1) Span shall wide enough to fully capture the emission being measured;
 - (2) Below 1GHz, RBW=120KHz, VBW=300KHz, Sweep=auto, Detector function=peak, Trace=max hold;
If the emission level of the EUT measured by the peak detector is 3 dB lower than the applicable limit, the peak emission level will be reported. Otherwise, the emission measurement will be repeated using the quasi-peak detector and reported.
 - (3) Above 1GHz, RBW=1MHz, VBW=3MHz for Peak value
RBW=1MHz, VBW=3MHz for Average value.

TEST RESULTS**Measurement data:**

Remark:

1. *Final Level = Receiver Read level + Antenna Factor + Cable Loss – Pre-amplifier Factor*
2. *"*" means this data is too weak instrument of signal is unable to test.*
3. *The emission levels of other frequencies are very lower than the limit and not show in test report.*

■ 9kHz ~ 30MHz

The low frequency, which started from 9 kHz to 30MHz, was pre-scanned and the result which was 20dB lower than the limit line per 15.31(o) was not reported.

■ 30MHz ~ 1GHz

Worst case mode	Vertical
-----------------	----------

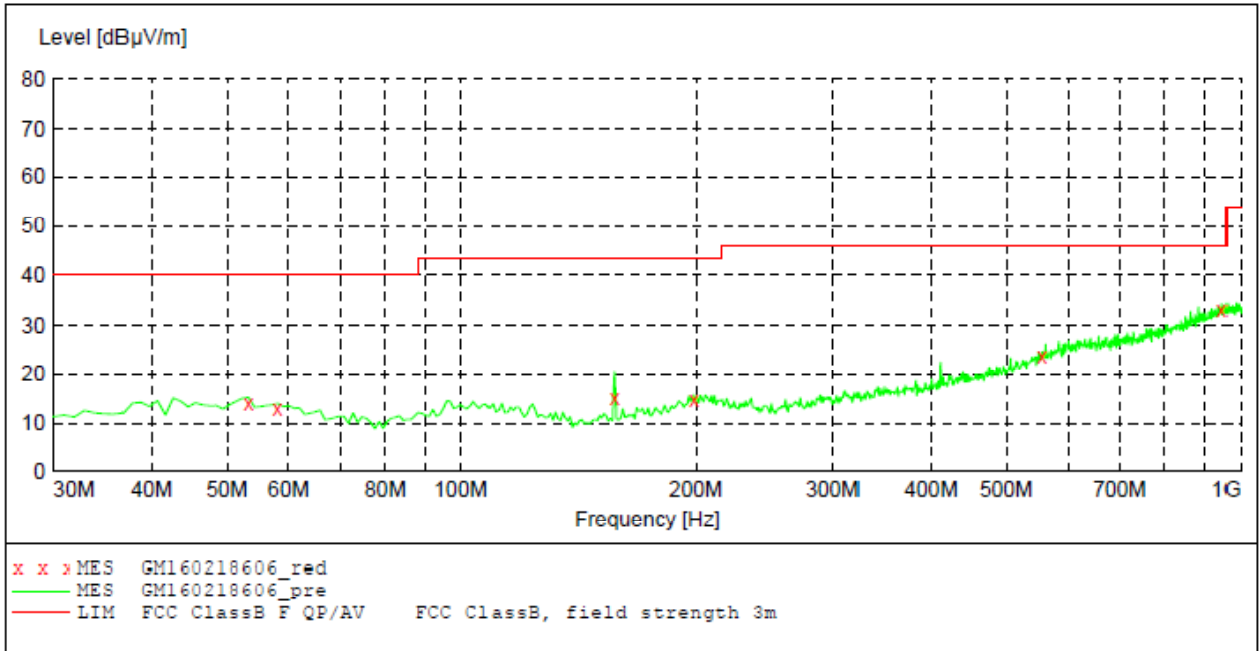

Frequency MHz	Level dBµV/m	Transd dB	Limit dBµV/m	Margin dB	Det.	Height cm	Azimuth deg	Polarization
53.280000	15.20	-14.6	40.0	24.8	QP	300.0	292.00	VERTICAL
58.130000	14.00	-15.0	40.0	26.0	QP	100.0	241.00	VERTICAL
157.070000	15.50	-17.4	43.5	28.0	QP	300.0	12.00	VERTICAL
198.780000	15.80	-13.7	43.5	27.7	QP	300.0	359.00	VERTICAL
555.740000	24.70	-4.6	46.0	21.3	QP	300.0	0.00	VERTICAL
946.650000	34.30	3.6	46.0	11.7	QP	300.0	267.00	VERTICAL

Worst case mode Horizontal

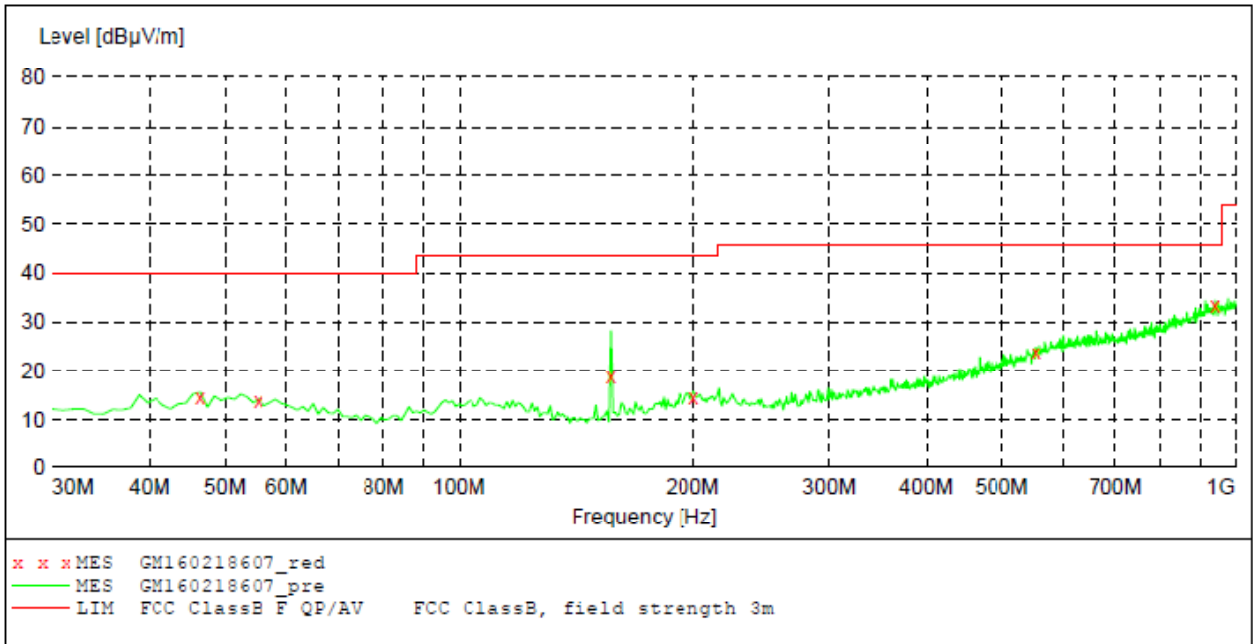

Frequency MHz	Level dBµV/m	Transd dB	Limit dBµV/m	Margin dB	Det.	Height cm	Azimuth deg	Polarization
46.490000	15.60	-14.6	40.0	24.4	QP	100.0	224.00	HORIZONTAL
55.220000	14.30	-14.7	40.0	25.7	QP	300.0	262.00	HORIZONTAL
157.070000	18.30	-17.4	43.5	25.2	QP	100.0	298.00	HORIZONTAL
200.720000	15.70	-13.6	43.5	27.8	QP	100.0	298.00	HORIZONTAL
552.830000	25.00	-4.8	46.0	21.0	QP	300.0	234.00	HORIZONTAL
942.770000	34.30	3.5	46.0	11.7	QP	100.0	110.00	HORIZONTAL

■ Above 1 GHz

CH00 for BLE Vertical

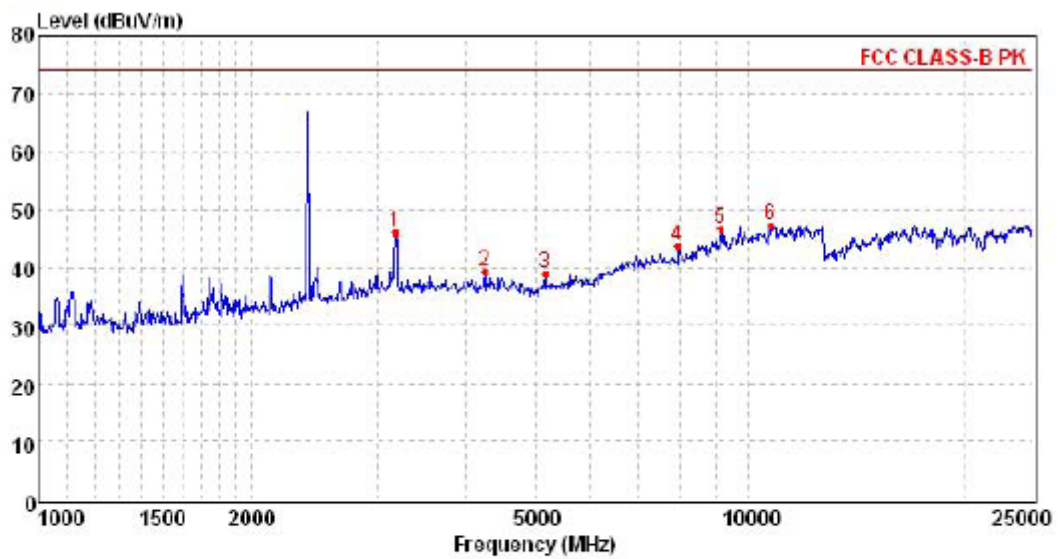

Mark	Frequency MHz	Reading dBuV/m	Antenna dB	Cable dB	Preamp dB	Level dBuV/m	Limit dBuV/m	Over limit	Remark
1	3184.25	47.19	28.58	8.42	37.99	46.20	74.00	-27.80	Peak
2	4256.33	38.40	30.24	8.81	38.17	39.28	74.00	-34.72	Peak
3	5177.97	36.28	31.64	9.45	38.51	38.86	74.00	-35.14	Peak
4	7961.43	34.18	36.68	11.23	38.25	43.84	74.00	-30.16	Peak
5	9134.58	35.01	37.95	11.76	37.98	46.74	74.00	-27.26	Peak
6	10750.81	33.49	38.95	13.06	38.14	47.36	74.00	-26.64	Peak

CH00 for BLE Horizontal

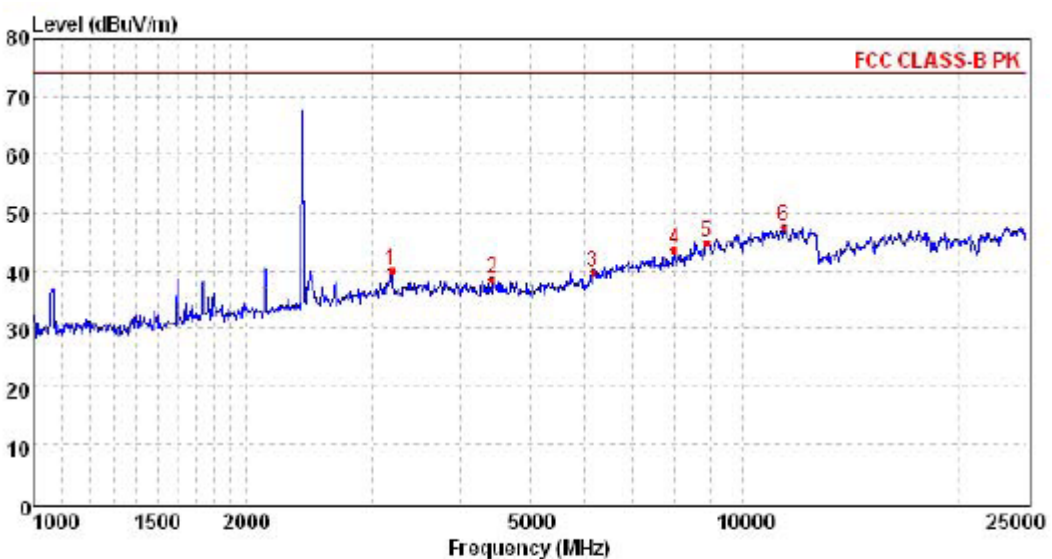

Mark	Frequency MHz	Reading dBuV/m	Antenna dB	Cable dB	Preamp dB	Level dBuV/m	Limit dBuV/m	Over limit	Remark
1	3200.50	41.24	28.58	8.43	37.99	40.26	74.00	-33.74	Peak
2	4444.56	37.24	30.76	8.94	38.30	38.64	74.00	-35.36	Peak
3	6156.51	33.95	33.81	9.95	37.93	39.78	74.00	-34.22	Peak
4	8022.46	34.08	36.72	11.24	38.24	43.80	74.00	-30.20	Peak
5	8904.99	33.51	37.80	11.59	37.97	44.93	74.00	-29.07	Peak
6	11428.08	33.00	39.11	13.46	37.91	47.66	74.00	-26.34	Peak

CH19 for BLE Vertical

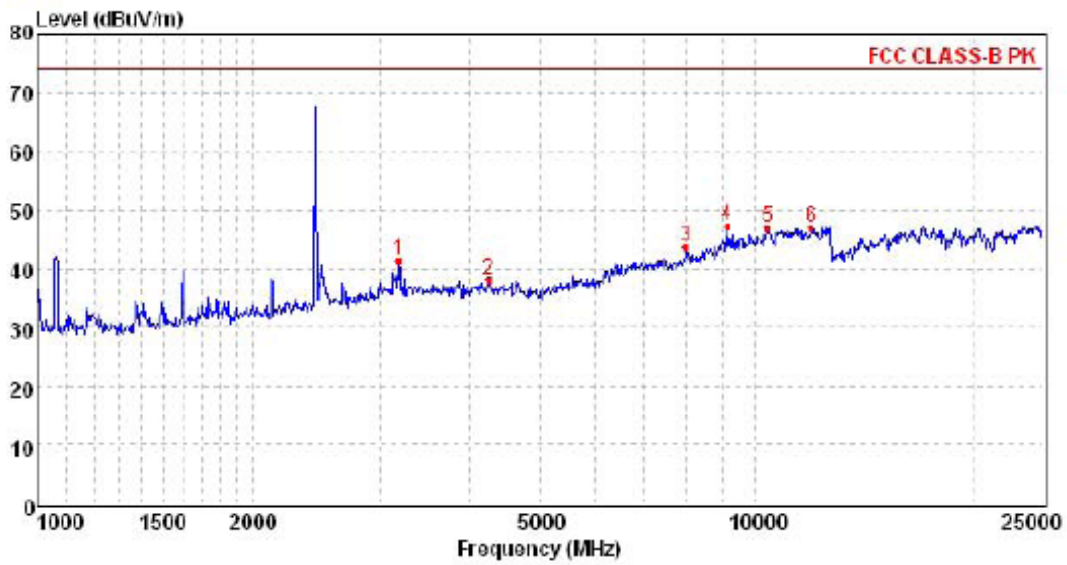

Mark	Frequency MHz	Reading dBuV/m	Antenna dB	Cable dB	Preamp dB	Level dBuV/m	Limit dBuV/m	Over limit	Remark
1	3192.37	42.28	28.58	8.43	37.99	41.30	74.00	-32.70	Peak
2	4256.33	37.24	30.24	8.81	38.17	38.12	74.00	-35.88	Peak
3	8022.46	34.00	36.72	11.24	38.24	43.72	74.00	-30.28	Peak
4	9134.58	35.49	37.95	11.76	37.98	47.22	74.00	-26.78	Peak
5	10427.37	33.68	38.65	12.81	38.14	47.00	74.00	-27.00	Peak
6	11994.38	31.86	39.10	13.73	37.61	47.08	74.00	-26.92	Peak

CH19 for BLE Horizontal

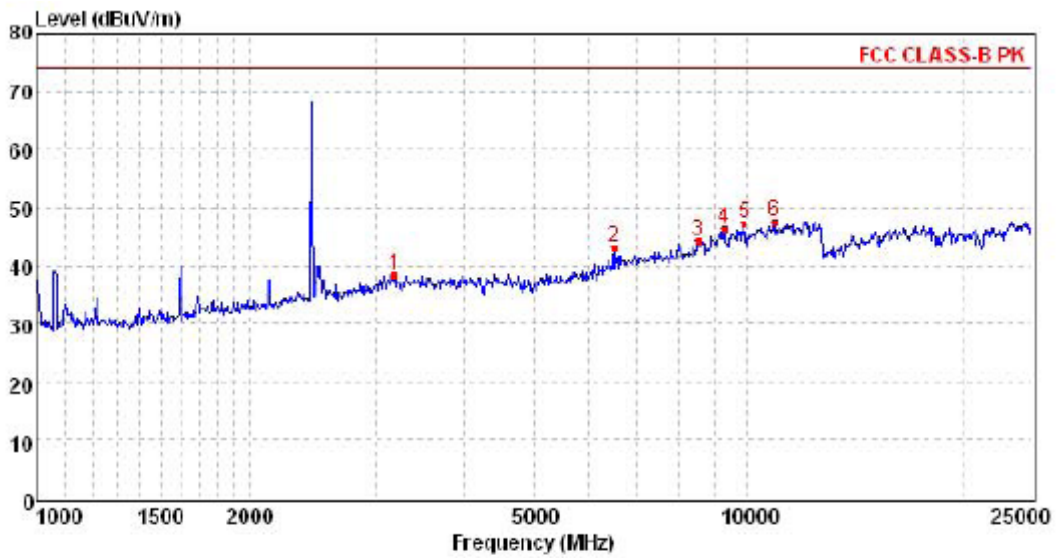

Mark	Frequency MHz	Reading dBuV/m	Antenna dB	Cable dB	Preamp dB	Level dBuV/m	Limit dBuV/m	Over limit	Remark
1	3192.37	39.29	28.58	8.43	37.99	38.31	74.00	-35.69	Peak
2	6511.12	35.68	35.10	10.35	37.98	43.15	74.00	-30.85	Peak
3	8549.59	33.90	37.27	11.30	38.08	44.39	74.00	-29.61	Peak
4	9298.80	34.48	38.02	11.88	38.01	46.37	74.00	-27.63	Peak
5	9909.80	34.49	38.35	12.42	38.12	47.14	74.00	-26.86	Peak
6	10944.09	33.44	39.14	13.19	38.14	47.63	74.00	-26.37	Peak

CH39 for BLE

Vertical

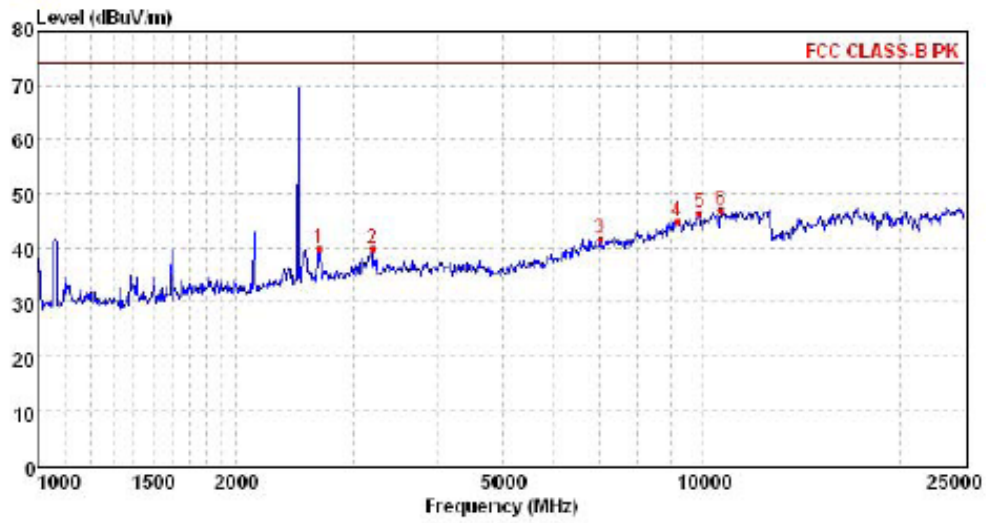

Mark	Frequency MHz	Reading dBuV/m	Antenna dB	Cable dB	Preamp dB	Level dBuV/m	Limit dBuV/m	Over limit	Remark
1	2664.54	42.20	28.11	7.38	37.77	39.92	74.00	-34.08	Peak
2	3200.50	40.93	28.58	8.43	37.99	39.95	74.00	-34.05	Peak
3	7027.82	33.05	35.83	10.78	38.07	41.59	74.00	-32.41	Peak
4	9204.60	33.20	37.98	11.82	37.99	45.01	74.00	-28.99	Peak
5	9909.80	33.66	38.35	12.42	38.12	46.31	74.00	-27.69	Peak
6	10696.21	33.30	38.89	13.01	38.14	47.06	74.00	-26.94	Peak

CH 39 for BLE

Horizontal

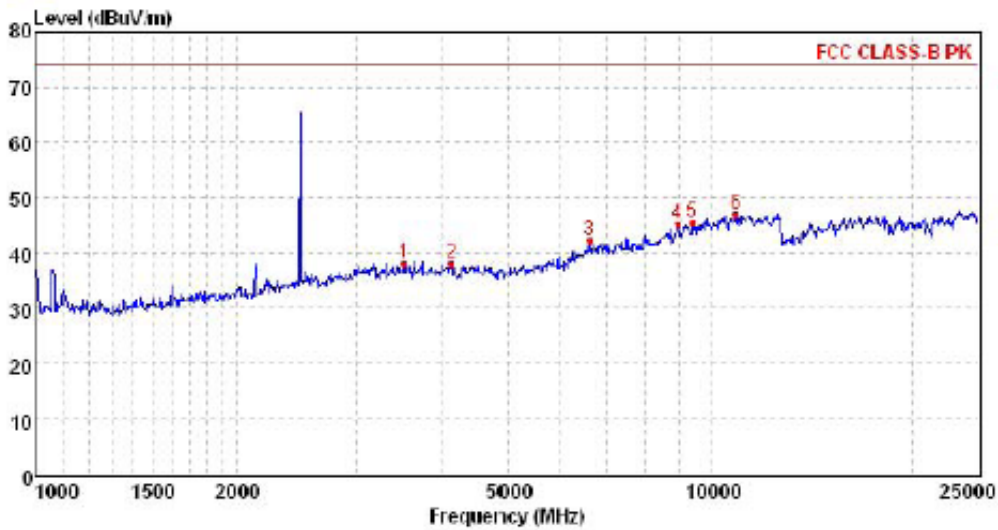

Mark	Frequency MHz	Reading dBuV/m	Antenna dB	Cable dB	Preamp dB	Level dBuV/m	Limit dBuV/m	Over limit	Remark
1	3534.54	38.39	28.77	8.79	37.99	37.96	74.00	-36.04	Peak
2	4149.35	37.66	29.92	8.72	38.09	38.21	74.00	-35.79	Peak
3	6611.33	34.51	35.24	10.44	38.00	42.19	74.00	-31.81	Peak
4	8950.44	33.65	37.83	11.64	37.96	45.16	74.00	-28.84	Peak
5	9417.91	33.51	38.07	11.95	38.03	45.50	74.00	-28.50	Peak
6	10916.26	32.80	39.11	13.19	38.14	46.96	74.00	-27.04	Peak

5. Test Setup Photos of the EUT

Radiated Emission

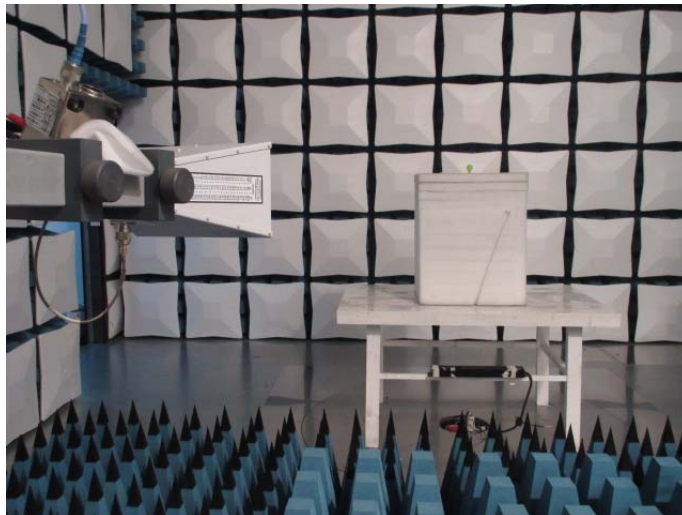

6. External and Internal Photos of the EUT External photos



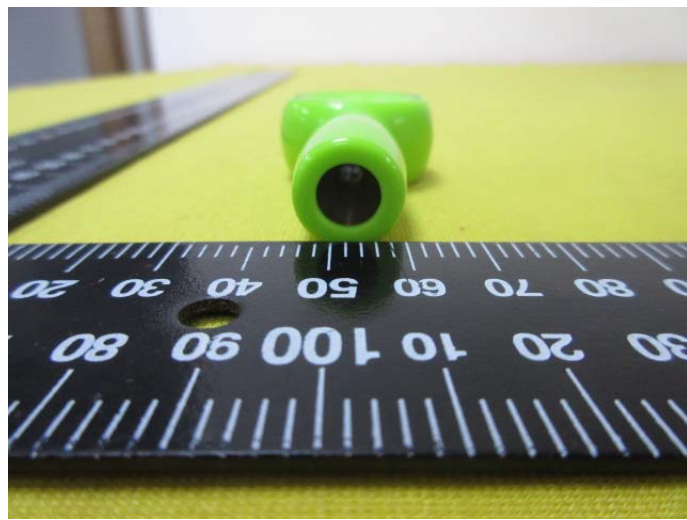



Internal photos

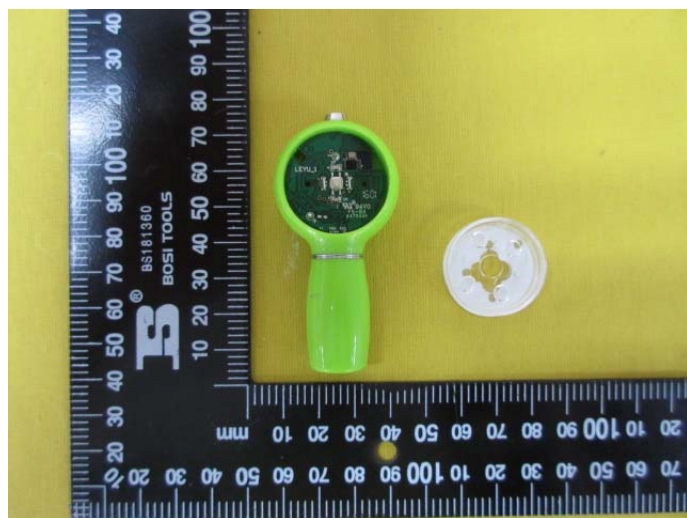
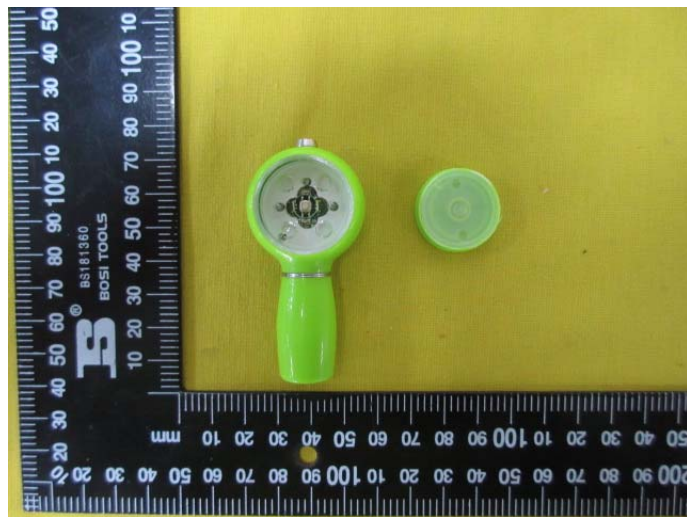

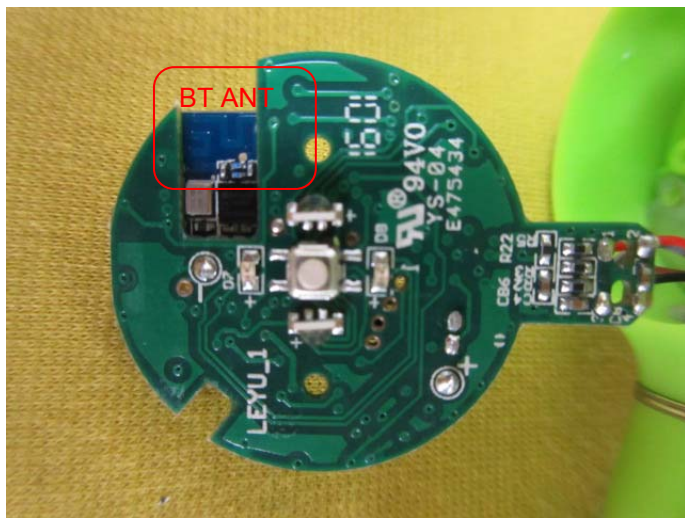
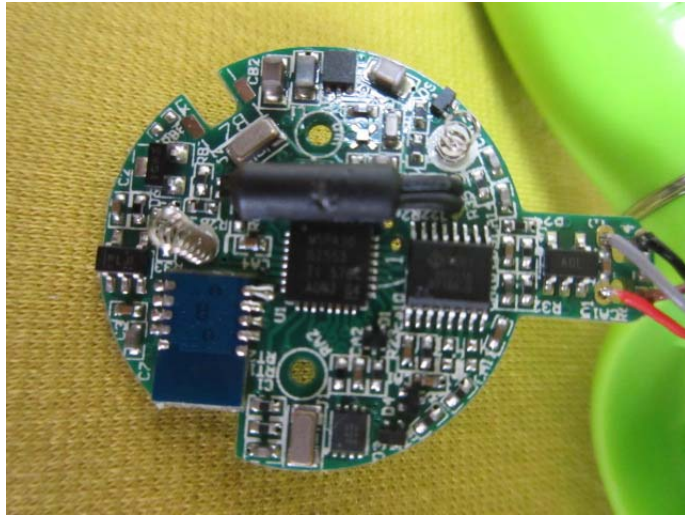

.....End of Report.....