

DT-3369T-BT

AC/DC TRMS CLAMP METER

With Mobile APP

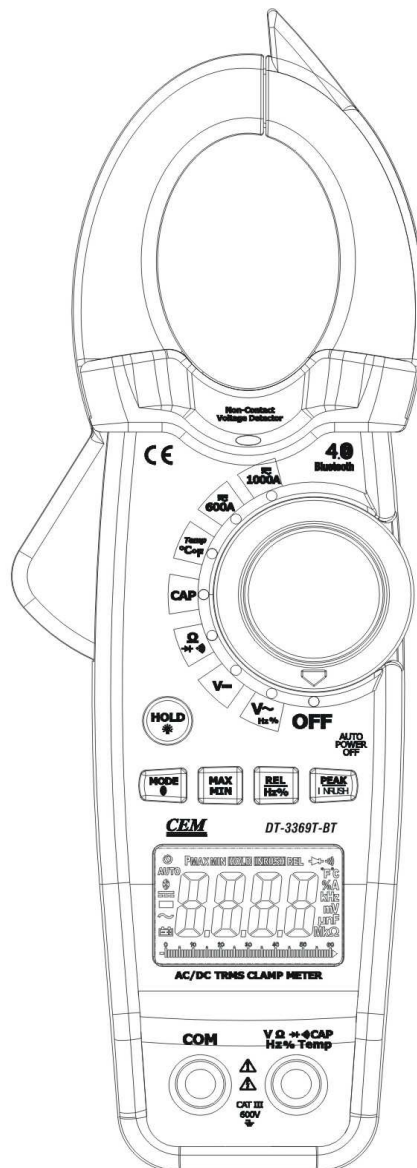

Safety

International Safety Symbols



This symbol, adjacent to another symbol or terminal, indicates the user must refer to the manual for further information.



This symbol, adjacent to a terminal, indicates that, under normal use, hazardous voltages may be present



Double insulation

SAFETY NOTES

- Do not exceed the maximum allowable input range of any function.
- Do not apply voltage to meter when resistance function is selected.
- Set the function switch OFF when the meter is not in use.
- Remove the battery if meter is to be stored for longer than 60 days.

WARNINGS

- Set function switch to the appropriate position before measuring.
- When measuring volts do not switch to current/resistance modes.
- Do not measure current on a circuit whose voltage exceeds 600V.
- When changing ranges always disconnect the test leads from the circuit under test.
- **Changes or modifications to this unit not expressly approved by the party responsible for compliance could void the user's authority to operate the equipment.**

Note: This equipment has been tested and found to comply with the limits for a Class B digital device, pursuant to Part 15 of the FCC Rules. These limits are designed to provide reasonable protection against harmful interference in a residential installation. This equipment generates, uses and can radiate radio frequency energy and, if not installed and used in accordance with the instructions, may cause harmful interference to radio communications. However, there is no guarantee that interference will not occur in a particular installation. If this equipment does cause harmful interference to radio or television reception, which can be determined by turning the equipment off and on, the user is encouraged to try to correct the interference by one or more of the following measures:

Reorient or relocate the receiving antenna

Increase the separation between the equipment and receiver

Connect the equipment into an outlet on a circuit different from that to which the receiver is connected

Consult the dealer or an experienced radio/TV technician for help.

The device must not be co-located or operating in conjunction with any other antenna or transmitter.

CAUTIONS

- Improper use of this meter can cause damage, shock, injury or death. Read and understand this user manual before operating the meter.
- Always remove the test leads before replacing the battery or fuses.
- Inspect the condition of the test leads and the meter itself for any damage before operating the meter. Repair or replace any damage before use.
- Use great care when making measurements if the voltages are greater than 25VAC rms or 35VDC. These voltages are considered a shock hazard.
- Always discharge capacitors and remove power from the device under test before performing Diode, Resistance or Continuity tests.
- Voltage checks on electrical outlets can be difficult and misleading because of the uncertainty of connection to the recessed electrical contacts. Other means should be used to ensure that the terminals are not "live".
- If the equipment is used in a manner not specified by the manufacturer, the protection provided by the equipment may be impaired.

Function	Maximum Input
A AC, A DC	1000A DC/AC
V DC, V AC	750V DC/AC
Resistance, Capacitance, Frequency, Diode Test	300V DC/AC
Temperature	300V DC/ AC



Description

Meter Description

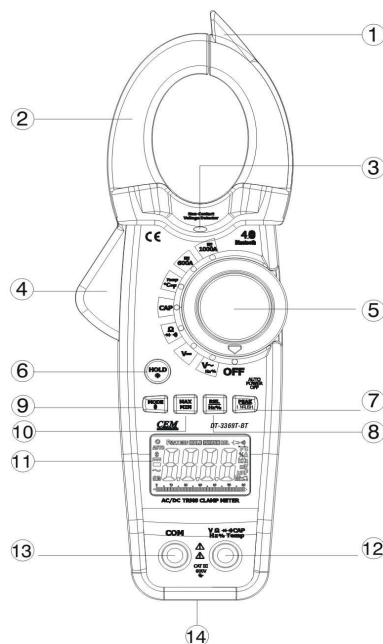
1. NCV Test
2. Current clamp
3. Non-contact AC voltage indicator light
4. Clamp trigger
5. Rotary Function switch
6. Data Hold and Backlight button
7. PEAK and INRUSH button
8. REL and HZ% button
9. MODE select and Bluetooth button
10. Max/Min button
11. LCD display
12. V Ω Diode Continuity CAP TEMP Hz% jack
13. COM input jack
14. Battery Cover



Display icons Description

HOLD	Data Hold
Minus sign	Negative reading display
0 to 5999	Measurement display digits
REL	REL/DCA Zero
MAX/MIN	Maximum/Minimum
	Auto Power Off
AUTO	Auto Range mode
DC/AC	Direct Current / Alternating Current
	Low battery
mV or V	Milli-volts or Volts (Voltage)
Ohms	(Resistance)
A	Amperes (Current)
F	Farad (Capacitance)
Hz/%	Hertz (Frequency)/Percent(duty ratio)
°F and °C	Fahrenheit and Celsius units (Temperature)
n, m, μ , M, k	Unit of measure prefixes: nano, milli, micro, mega, and kilo
•)))	Continuity test
→+	Diode test
	Bluetooth4.0

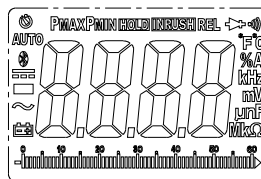

Specifications

Function	Range	Resolution	Accuracy (% of reading + digits)
AC True RMS Current (Auto Rang)	60.00	10 mA	$\pm 2.5\%$ of rdg ± 8 digits
	600.0A	100mA	$\pm 2.5\%$ of rdg ± 8 digits
	1000A	1A	$\pm 2.8\%$ of rdg ± 8 digits

Over rang protection: Maximum input 1000A

Accuracy specified from 5% to 100% of the measuring range

Frequency Response: 50Hz to 60Hz True RMS

Function	Range	Resolution	Accuracy (% of reading + digits)
DC Current (Auto Rang)	60.00A	10mA	$\pm 2.5\%$ of rdg ± 8 digits
	600.0A	100mA	$\pm 2.5\%$ of rdg ± 8 digits
	1000A	1A	$\pm 2.8\%$ of rdg ± 8 digits

Over rang protection: Maximum input 1000A

Function	Range	Resolution	Accuracy (% of reading + digits)
DC Voltage (Auto-ranging)	600.0mV	0.1mV	$\pm 0.9\%$ of rdg ± 5 digits
	6.000V	1mV	$\pm 1.0\%$ of rdg ± 3 digits
	60.00V	10mV	$\pm 1.0\%$ of rdg ± 3 digits
	600.0V	100mV	$\pm 1.0\%$ of rdg ± 3 digits

Maximum Input: 750V dc

Function	Range	Resolution	Accuracy (% of reading + digits)
AC True RMS Voltage (Auto-ranging)	6.000V	1mV	$\pm 1.2\%$ of rdg ± 5 digits
	60.00V	10mV	$\pm 1.2\%$ of rdg ± 5 digits
	600.0V	100mV	$\pm 1.5\%$ of rdg ± 5 digits

AC Response: 50 Hz to 1kHz

Accuracy specified from 5% to 100% of the measuring range

Accuracy PEAK function: $\pm 10\%$ rdg

Maximum Input: 750V ac rms.

Function	Range	Resolution	Accuracy (% of reading + digits)
Resistance (Auto-ranging)	600.0 Ω	0.1 Ω	$\pm 1\%$ of rdg ± 4 digits
	6.000k Ω	1 Ω	$\pm 1.5\%$ of rdg ± 2 digits
	60.00k Ω	10 Ω	$\pm 1.5\%$ of rdg ± 2 digits
	600.0k Ω	100 Ω	$\pm 1.5\%$ of rdg ± 2 digits
	6.000M Ω	1k Ω	$\pm 2.0\%$ of rdg ± 5 digits
	60.00M Ω	10k Ω	$\pm 3\%$ of rdg ± 8 digits

Input Protection: 300V dc or 300V ac rms.

Function	Range	Resolution	Accuracy (% of reading + digits)
Capacitance (Auto-ranging)	60.00nF	10pF	±5% of rdg ± 30digits
	600.0nF	0.1nF	±3% of rdg ± 5digits
	6.000uF	1nF	±3% of rdg ± 5digits
	60.00uF	10nF	±3% of rdg ± 5digits
	600.0uF	0.1uF	±4% of rdg ± 10digits
	6000uF	10uF	±4.5% of rdg ± 10digits

Input Protection: 300V dc or 300V ac rms.

Accuracy is not stated below 6nF

Frequency with test leads(AC Voltage)

Function	Range	Accuracy ±(% of reading + digits)
Frequency (Auto-ranging)	10Hz to 20kHz	±(1.0% +5 digits)

Input Protection:750V AC rms

Sensitivity: >15V AC rms

Function	Range	Accuracy ±(% of reading + digits)
Frequency	40Hz to 1kHz	±(1.0% +5 digits)

Maximum Input: 1000A AC

Sensitivity: >50A (600A range)

>500A (1000A range)

Function	Range	Resolution	Accuracy (% of reading + digits)
Duty Cycle	20.0%~80.0%	0.1	±1.2% of rdg ± 10digits

Function	Range	Resolution	Accuracy (% of reading + digits)
Temperature	-20°C~+760°C	0.1/1 °C	±3% of rdg ± 5 °C
	-4 °F~+1400 °F	0.1/1 °F	±3% of rdg ± 9°F

Sensor: Type K Thermocouple

Input Protection: 300V dc or 300V ac rms.

Function	Testing Condition	Reading
Diode	Forward DCA is approx.1mA, open circuit Voltage MAX . 3V	Forward voltage drop of Diode
Continuity	Test current MAX. 1.5mA	Buzzer makes a long sound, While resistance is less than(50Ω)

Input Protection: 300V dc or 300V ac rms.

General Specifications

Clamp jaw opening	1.2" (30mm) approx.
Blue tooth	4.0
Display	3-6/7 digits (6000 counts) backlit LCD
Continuity check	Threshold 50Ω; Test current < 0.5mA
Diode test	Test current of 0.3mA typical; Open circuit voltage < 3VDC typical
Low Battery indication	 is displayed
Over-range indication	'OL' display
Measurement rate	3 readings per second, nominal
PEAK	Captures peaks >1ms
INRUSH	100MS
Temperature sensor	Type K thermocouple
Input Impedance	10MΩ (VDC and VAC)
AC response	True rms (AAC and VAC)
Operating Temperature	41°F to 104°F (5°C to 40°C)
Storage Temperature	-4°F to 140°F (-20°C to 60°C)
Operating Humidity	Max 80% up to 87°F (31°C) decreasing linearly to 50% at 104°F(40°C)
Storage Humidity	<80%
Operating Altitude	7000ft. (2000meters) maximum.
Battery	One (1) 9V Battery
Auto power OFF	After approx. 15 minutes
Dimensions & Weight	239 x 80 x 49mm; 305g
Safety	For indoor use and in accordance with the requirements for double insulation to IEC1010-1 (2001); EN61010-2-030 EN61010-2-032 EN61010-2-033 Overvoltage Category III 600V, Pollution Degree 2.

measuring.

1. Set the function switch to the **CAP** position.
2. Insert the black test lead banana plug into the negative **COM** jack and the red test lead banana plug into the **V- \rightarrow -CAP-TEMP-Hz%- Ω** positive jack.
3. Touch the test probe tips across the part under test. If “**OL**” appears in the display, remove and discharge the component.
4. Read the capacitance value in the display.
5. The display will indicate the proper decimal point and value.

Note: For very large values of capacitance measurement it can take several minutes before the final reading stabilizes.

Frequency Measurements

1. Insert the black test lead banana plug into the negative **COM** jack and the red test lead banana plug into the **V- \rightarrow -CAP-TEMP-Hz%- Ω** positive jack.
2. Set the function switch to the **V~** Position.
3. Press **HZ/%** button to select the Frequency (Hz) or Duty cycle (%).
4. Touch the test probe tips across the part under test.
5. Read the value on the display.
6. The display will indicate the proper decimal point and value.
7. In Voltage and Current mode Press **HZ/%** button to select the Frequency (Hz) or Duty cycle (%).

Temperature Measurements

1. Set the function switch to the **TEMP** position.
2. Insert the Temperature Probe into the negative **COM** and the **V- \rightarrow -CAP-TEMP-Hz%- Ω** positive jacks, observing polarity.
3. Touch the Temperature Probe head to the device under test. Continue to touch the part under test with the probe until the reading stabilizes.
4. Read the temperature on the display. The digital reading will indicate the proper decimal point and value.
5. Use the **MODE** button to select °F or °C.

WARNING: To avoid electric shock, be sure the thermocouple probe has been removed before changing to another measurement function.

Continuity Measurements

1. Insert the black test lead into the negative **COM** terminal and the red test lead into the **V- \rightarrow -CAP-TEMP-Hz%- Ω** positive terminal.

2. Set the function switch to the $\Omega \rightarrow \bullet$ position.
3. Use the **MODE** button to select continuity “ \bullet ””. The display icons will change when the **MODE** button is pressed.
4. Touch the test probe tips across the circuit or component under test.
5. If the resistance is $< 50\Omega$, a tone will sound.

Diode Test

1. Insert the black test lead banana plug into the negative **COM** jack and the red test lead banana plug into the **V** positive jack
2. Turn the function switch to $\Omega \rightarrow \bullet$ position. Use the **MODE** button to select the diode function if necessary (diode symbol will appear on the LCD when in Diode test mode)
3. Touch the test probe tips to the diode or semiconductor junction under test. Note the meter reading
4. Reverse the test lead polarity by reversing the red and black leads. Note this reading
5. The diode or junction can be evaluated as follows:
 - If one reading displays a value (typically 0.400V to 0.900V) and the other reading displays **OL**, the diode is good.
 - If both readings display **OL** the device is open.
 - If both readings are very small or '0', the device is shorted.

Non-Contact AC Voltage Measurements

WARNING: Risk of Electrocution. Before use, always test the Voltage Detector on a known live circuit to verify proper operation

1. Touch the probe tip to the hot conductor or insert into the hot side of the electrical outlet.
2. If AC voltage is present, the detector light will illuminate.
 1. **NOTE:** The conductors in electrical cord sets are often twisted. For best results, rub the probe tip along a length of the cord to assure placing the tip in close proximity to the live conductor.
 2. **NOTE:** The detector is designed with high sensitivity. Static electricity or other sources of energy may randomly trip the sensor. This is normal operation

Mode/Bluetooth

Press Mode/Bluetooth key the selection of double measured functions which are present at display is possible. In particular this key is active in **V** position to select among resistance test, diode test, continuity test, and in Temp position to select

between °F or °C. and in current position to select between AC or DC current measurements.

To press and hold the mode key to turn the system on, the auto power off function will be cancelled.

Press the Mode/Bluetooth until the Bluetooth turns on or off.

PEAK/ INRUSH

NOTE: Only ACV functions can do the peak value measurement.

PEAK Key is the peak value measurement key that acts with trigger.

NOTE: Only ACA functions can do the **INRUSH** value measurement.

1. Close motor and then install Jaw or Flexible coil
2. Press the INRUSH button , “----”will appear in the display.
3. Open motor and then read the value on the display.

Data Hold/Backlight

To freeze the LCD reading, press the **HOLD** button. While data hold is active, the **HOLD** icon appears on the LCD. Press the **HOLD** button again to return to normal operation.

The LCD is equipped with backlighting for easier viewing, especially in dimly lit areas. Press the backlight button to turn the backlight on. Press again to turn the backlight off.

Note :

that the meter does have an auto power off feature as described below.

Relative

1. Press the **REL** button to zero the display. “ **REL** ” will appear in the display. The displayed reading is now the actual value less the stored “zero” value.
2. Press the **REL** button to view the stored value. “ **REL** ” will flash in the display.
3. To exit this mode, press and Hold the **REL** button until “ **REL** ” is no longer in the display.

MAX/MIN

Press MAX/IN key the maximum and minimum values are measured. This mode is activated on each measurement except for continuity test, diode test capacitance test, frequency test and duty cycle test.

This mode is disabled keeping pressed MAX/MIN key or moving the rotary switch.

HZ/%

With rotary switch on HZ/%, Voltage, Current, positions, the Hz% key permits to select the frequency test (Hz) or the duty cycle test(%).

LCD Backlight Button

The LCD is equipped with backlighting for easier viewing, especially in dimly lit areas. Press the backlight button to turn the backlight on. Press again to turn the backlight off. Note that the meter does have an auto power off feature as described below.

Automatic Power OFF

In order to conserve battery life, the meter will automatically turn off after approximately 15 minutes. To turn the meter on again, turn the function switch to the OFF position and then to the desired function position.

Maintenance

WARNING: To avoid electrical shock, disconnect the meter from any circuit, remove the test leads from the input terminals, and turn OFF the meter before opening the case. Do not operate the meter with an open case.

Cleaning and Storage

Periodically wipe the case with a damp cloth and mild detergent; do not use abrasives or solvents. If the meter is not to be used for 60 days or more, remove the battery and store it separately.

Battery Replacement

1. Remove the Phillips head screw that secures the rear battery door
2. Open the battery compartment
3. Replace the 9V battery
4. Secure the battery compartment

Temperature Probe Replacement

The replacement bead wire probe (with banana plug connectors) is Part Number TP873.

Note: To use a Type K thermocouple probe that is terminated by a subminiature (flat blade) connector, a subminiature-to-banana plug adaptor (Part Number TP879) is required.