

## Installation Guide

### Model TBZ500 Battery Powered Z-Wave Thermostat

This thermostat is compatible with most HVAC systems, including the following:

- 24VAC systems Note: requires both the R and C wires unless battery powered.
- Standard gas/oil/electric heating systems
  - 1 stage heating and cooling
  - 2 stage heating and cooling
- Heat Pump systems:
  - 1 stage heating and cooling
  - 2 stage heating and cooling
  - 2<sup>nd</sup> or 3<sup>rd</sup> stage Auxiliary heating (heat strips)
- Do NOT use for line voltage controls (120/240VAC)

The thermostat can be powered by batteries or 24VAC.

#### Battery Power

The thermostat can be powered by four AA Alkaline batteries. The thermostat will operate for approximately two years on four AA Alkaline batteries depending on the frequency of user operations and backlight operation. Always use Alkaline batteries and replace in complete all four at a time with new batteries.

#### Z-Wave Operation when Battery Powered

Important Note: If the thermostat is installed on a Z-Wave network, **while it is battery powered**, it will not work as a Z-Wave repeater.

#### 24VAC Power

Powering the thermostat with 24VAC power **requires** both the C wire (24VAC common wire - typically blue) and the R wire (24VAC hot wire - typically red). If the C wire is not available, then batteries are required.

**Note! If the thermostat is powered from 24VAC, batteries are not required.**

#### Z-Wave Operation when 24VAC powered

If the thermostat is installed on a Z-Wave network **while it is 24VAC powered**, it operates as an always-on Z-Wave repeater.

## Installation Steps

- Remove old thermostat.
- Install TBZ500
- Set up the thermostat for the HVAC system
- Enroll on Z-Wave network

#### Remove old thermostat

- Turn off power. Usually at the heating/cooling system or circuit- breaker panel.
- Remove cover of old thermostat to expose the wiring terminals
- **Take a picture of the wiring terminals! Note: This will help with troubleshooting later if needed.**
- **Mark the wires attached to the terminals with the wiring labels included**

- Use the terminal labels and not the wiring color to mark the wires
- Remove the old thermostat base
- Caution. Don't let the wires slip into the wall.

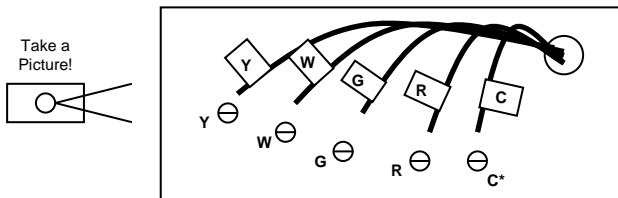

\*Note: the C wire (24V common) may not be present.

If there is no C wire, the TBZ500 must be powered by batteries.

If the C wire is present, you can power the thermostat without batteries

Mark the wires according to the terminal markings. There may be additional wires. Mark these according to the terminals. Y1, Y2, W1, W2, O, B.

**Wiring colors.** While the wiring terminals markings are intended to match the wire color (R=red, G=green, W=white, Y=yellow), not all installations were correctly installed this way. Be sure to follow the terminal marking when marking the wires, even if the wire color doesn't match.

**The C wire.** If the 24VAC Common wire (usually Blue) is present and is connect to 24VAC common at the HVAC system end, the thermostat can be powered from the HVAC system and batteries are not required. If there is no Common wire, batteries are required.

## Mount the thermostat base

Mount the thermostat base to the wall using the wall anchors and screws provided. Level as needed.

## Connect the wires – most common connections

### Single Stage Gas Heating/Cooling HVAC System Wiring to the Thermostat

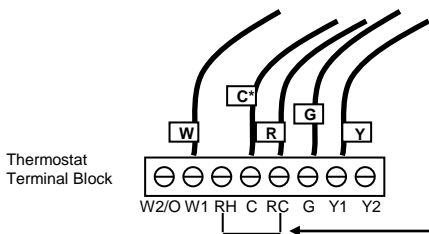

Connect the wires as marked from the HVAC system to the corresponding terminals on the thermostat back.

\*C wire (24VAC common) may not be present. If not, batteries must be installed.

Factory installed RC and RH jumper

### **R vs RC and RH Connections:**

Typical HVAC installations will have a common heating and cooling system 24VAC transformer. For these systems, there is only one 24VAC "R" wire and it can connect to either the RC or RH terminal on the thermostat. The thermostat is supplied with an RC-RH jumper installed. Do not remove the jumper for common transformer HVAC systems.

Some installations may have separate heating and cooling systems/transformers. For those systems there will be a separate "R" wire for the heating (RH) and cooling transformers (RC).

To connect dual transformer systems, FIRST REMOVE THE SUPPLIED RH-RC JUMPER. Then connect the heating "R" wire to the RH terminal and the cooling "R" wire to the RC terminal on the thermostat.

**Single Stage Heat Pump HVAC System Wiring to the Thermostat**

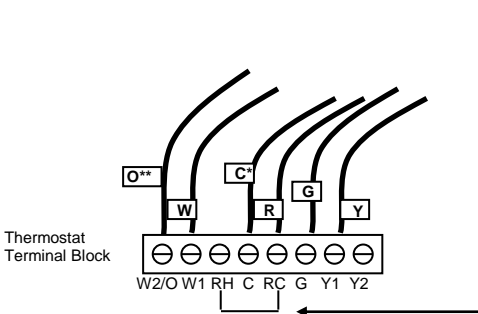

Connect the wires as marked from the HVAC system to the corresponding terminals on the thermostat back.

\*C wire (24VAC common)  
Heat Pump systems usually have the C wire connected to the thermostat. If there isn't a C wire, batteries must be installed.

\*\* O or B wires (changeover valve) connect to the W2/O terminal on the thermostat. Set the correct changeover operation (O = change over with cool, B = changeover with cool) in the SETUP menu.

Connect the R wire to either RC or RH terminals.

Factory installed RC and RH jumper

If you have additional wires, see the wiring diagrams on page 5 and 6.

Check that the wires are screwed into the terminal blocks firmly. Gently pull on the wires to confirm the connection. Push all the excess wiring back into the wall.

**Mount the thermostat**

If the thermostat is 24VAC powered (24VAC common "C" wire connected). DO NOT INSTALL BATTERIES!

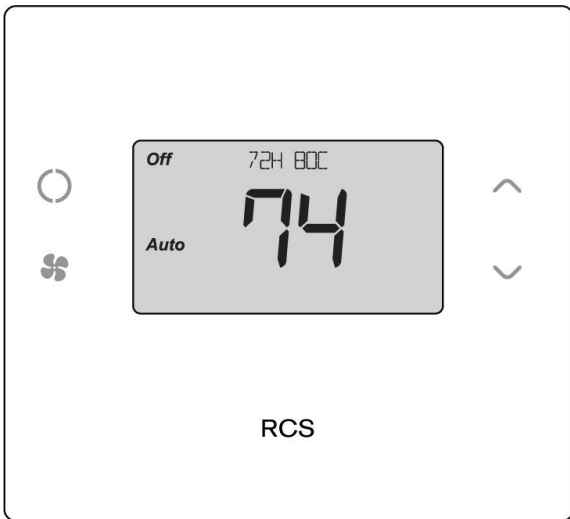

Install the thermostat on to the base. Turn on power to the thermostat.

If the thermostat is battery powered (NO 24VAC C wire connected), install 4 AA batteries into the back of the thermostat.

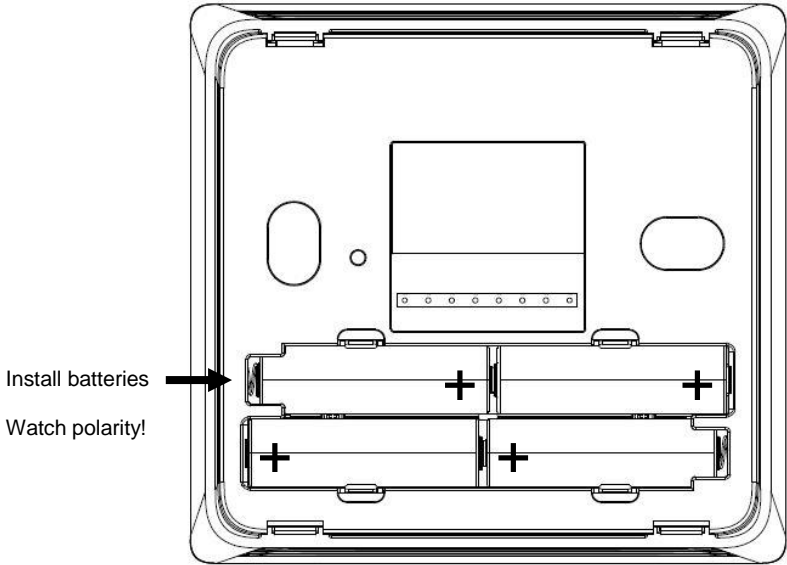

Install the thermostat on to the base.  
Turn on power to the thermostat.

# Standard Gas/Electric HVAC System Wiring

Typical thermostat wiring colors.  
Caution: verify that original wiring matches. Colors may be different.

## Standard HVAC System

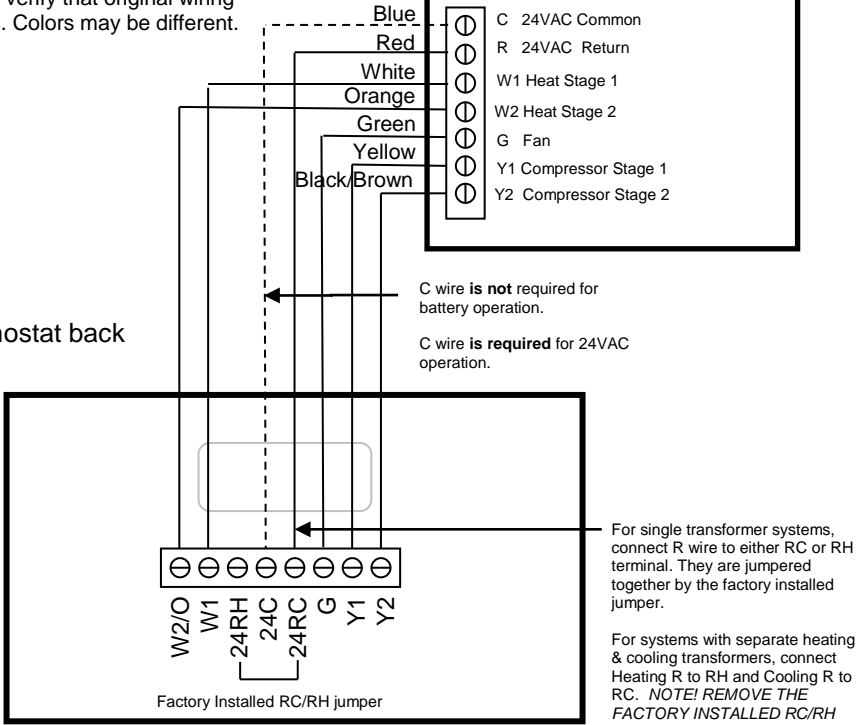
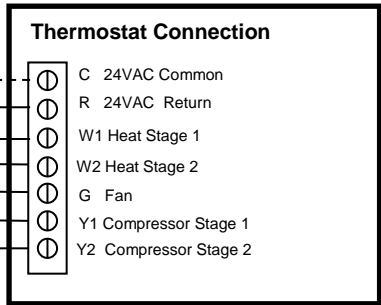

## Thermostat Setup: Standard Gas/Electric HVAC Systems

For Single Stage Heat/Cool Systems:  
Go to the Menu screen by pressing and holding the FAN button for 5 seconds  
Press the down arrow to select the **SYSTEM** menu and press Select.  
Set the following:

- SYSTEM TYPE:** Set to **STANDARD**  
**FAN TYPE:** Set to **GAS** for typical gas furnace (fan is controlled by the furnace)  
 Set to **ELECTRIC** for electric heat (fan on with heat call)

For Two Stage Heat/Cool Systems:  
Go to **ADVANCED SYSTEMS SETTINGS** menu.  
From the **Setup menu** screen, press and hold the Fan and Down arrow buttons for 5 seconds. Use the Down arrow button to select the following:

- 2ND STAGE HEAT ENABLE:** Enable second stage heating output  
 If a single stage heating system, leave this set to **N**  
 If a 2 stage heating system, set to **Y** to enable.
- 2ND STAGE COOL ENABLE:** Enable second stage cooling output  
 If a single stage cooling system, leave this set to **N**.  
 If a two stage cooling system, set to **Y** to enable.

### Default Thermostat Setup:

Type: Standard HVAC  
 Fan Type: Gas Heat  
 1 Stage heating  
 1 Stage cooling

**No Setup change required  
for this configuration**

# Heat Pump HVAC System Wiring

## Heat Pump HVAC System

Typical thermostat wiring colors.  
Caution: verify that original wiring matches. Colors may be different.

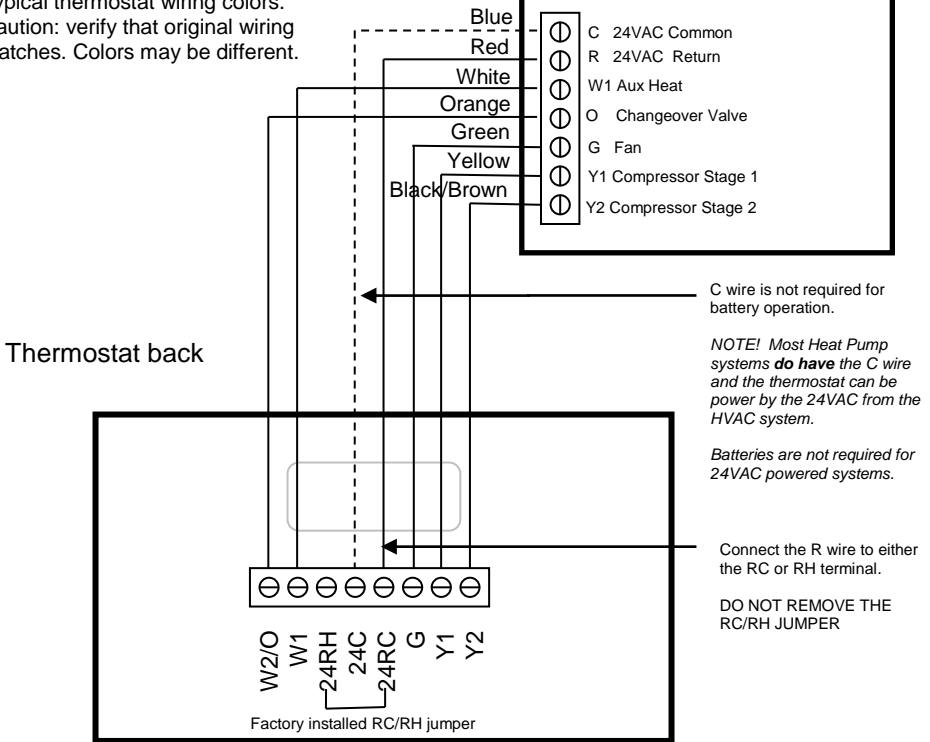

### Thermostat Setup: Heat Pump HVAC Systems

#### For Single Stage Heat/Cool Systems:

Go to the Menu screen by pressing and holding the FAN button for 5 seconds. Press the down arrow to select the **SYSTEM** menu and press Select. Set the following:

**SYSTEM TYPE:** Set to **HEAT PUMP**

**CHANGE OVER:** For changeover with cooling systems (Orange wire): set to **WITH COOL** (most common and default setting)

For changeover with heating systems (Brown wire): set to **WITH HEAT**

You must configure the thermostat's changeover valve setting to work correctly with your HVAC system.

Check your system information to be sure and note the color of original thermostat wire and the terminal it was connected to.

No matter what the old stat connection was (O or B), connect the wire to the thermostats W2/O terminal.

For Two Stage Heat/Cool Systems:

Go to **ADVANCED SYSTEMS SETTINGS** menu. From the **Setup menu** screen, press and hold the Fan and Down arrow buttons for 5 seconds. Use the Down arrow button to select the following:

**AUXHEAT:** If you have auxiliary heat strips, set this to **Y** to enable. (Default is Y)

**2ND STAGE HEAT ENABLE:** Enable second stage heating outputs

If a single stage heating system, leave this set to **N**

If a 2 stage heating system, set to **Y** to enable.

**2ND STAGE COOL ENABLE:** Enable second stage cooling outputs

If a single stage cooling system, leave this set to **N**.

If a two stage cooling system, set to **Y** to enable.

**Note!** If you get heating when you expected cooling or vice versa, change the **Change Over** type to the **opposite setting**.

# Thermostat Setup

The thermostat must be setup for the correct system type and configuration of the HVAC system for proper operation.

## **Preset HVAC System settings**

The thermostat is preset for the following typical HVAC system configuration:

- HVAC system type: Standard gas/electric
- HVAC fan type: Gas heat
- HVAC heating stages: one
- HVAC cooling stages: one

***If the thermostat is installed on this type HVAC system, the System setup does not need to be changed.***

If installed on a Heat Pump HVAC system or any HVAC configuration other than the preset settings, change the System settings in the **SYSTEM** setup menu to match the HVAC system.

## **Changing the HVAC system setup**

The thermostat normally displays the Thermostat Main Control Screen. To change the thermostats HVAC system settings, select the Menu Screen and then select the SYSTEM menu. Follow instructions below to access the SYSTEM menu.

*Note: To conserve battery life, the thermostat backlight turns off after a short time of no activity. The **first** press of **any** button turns on the backlight (but does not initiate any action). Press the button **again** to initiate the action desired. If the backlight is already on, button presses work with the first press.*

## **Thermostat Main Screen**

The thermostat Main screen shows the basic thermostat settings and controls. It allows you to set the temperature setpoints and the operating modes of the HVAC system. To change the thermostat setup and other user options, first select the thermostat Menu screen.

**To select the Menu screen,** press and hold the FAN button until the Setup screen is displayed

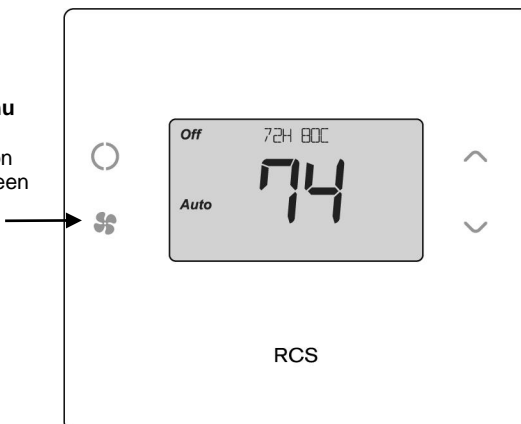

## Thermostat Menu Screen

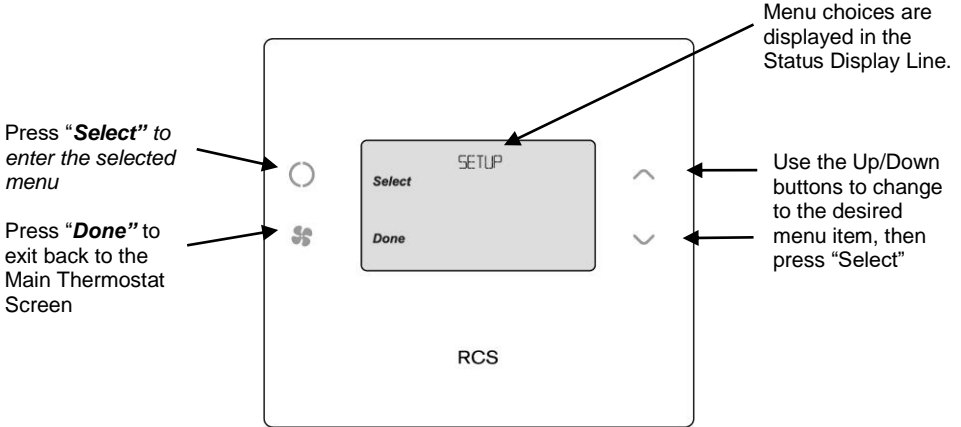

## Selecting the Menu Options

When the Thermostat Menu Screen is displayed, use the Up or Down arrow buttons to scroll through the following options:

- **SETUP** (user preference settings)
- **SYSTEM** (HVAC system setup)
- **ZWAVE** (install/uninstall from Z-Wave network)
- **CLOCK** (set the time and day)
- **INFO** (firmware versions and Z-Wave network information)

## SYSTEM SETUP

To change the HVAC system default settings, scroll down to the **SYSTEM** item and press "Select".

## SYSTEM Menu

The SYSTEM menu is used to setup the thermostat for the correct HVAC system type.

- **HVAC System Type:** Standard Gas/Electric or Heat Pump
- **Fan Type:** Gas Heating or Electric Heating
- **Changeover Valve Type** (for Heat Pump Systems): Changeover with Cooling or with Heating.

When SYSTEM is selected in the Menu options, the following **setup** options will be displayed in the text line.

- Use the UP/Down arrow buttons to scroll to the desired setting.
- Press "Select" to change a setting. The current setting for that selection will be flashing.
- Change the selection with the Up/Down arrows.
- When the desired setting has been selected, Press "Select" again to save it.
- Then press "Done" to exit.

## System Type

- For Standard Gas/Electric systems, select "**Standard**". This is the default setting.
- For Heat Pump systems, use the Up/Dn arrows to change to "**Heat Pump**"



- Press Select to set.
- Press Done to exit

### **Fan Type (For Standard HVAC systems only)**

Fan type depends on the heating system type.

- For Gas heat: select “**GAS**”. This is the default setting.
- For Electric heat: use the Up/Dn arrows to change to “**ELECTRIC**”.
- Press Select to set
- Press Done to exit

### **Changeover Type (For Heat Pump HVAC systems only)**

The changeover (or reversing) valve is used to change from heating to cooling operation. It is either a changeover with cooling type or changeover with heating type. Most are changeover with cooling, which is the default setting.

- For Changeover with Cooling systems, select “**WITH COOL**”. This is the default setting.
- For Changeover with Heating systems, use the Up/Dn arrows to change to “**WITH HEAT**”.
- Press Select to set
- Press Done to exit

Not sure what type Changeover system? Check the existing thermostat connections to help determine this. If the original system had an **orange** wire connected to an “**O**” terminal, then this is a “**changeover with cool**” system. If there was a **brown** wire connected to a “**B**” terminal, then this is a “**change over with heat**” system. Set the Change Over setting accordingly. (Caution: These are typical wiring colors/connections)

**Note: If heating comes on when cooling is expected or vice versa, change the “Change Over Type” to the opposite setting.**

### **Advanced System Settings Menu**

The Advanced System Settings Menu provides for additional system setup options. These settings can affect system operation and should only be changed by qualified HVAC installers.

To access the Advanced System Settings menu, first press and hold the Fan button to get into the **Setup** menu. While in the Setup Menu, press and hold both the **Fan** and **Down Arrow** buttons for 5 seconds. The first menu item in the Advance System Settings menu “Display Lock”, will be displayed. Use the Up/Down arrow buttons to scroll through the menu options to the desired setting. Press “Select” (Mode) button to change a setting. Once it begins to flash, use the Up/Down buttons to select the desired setting. Press the “Select” button to accept the new setting (flashing will stop).

### **Advanced Settings**

#### **Display Lock**

Range: Y or N

Default: N

Y = Display LOCKED

N = Display UNLOCKED

Allows the thermostat buttons to be locked. When the buttons are locked, none of the thermostat buttons will function.

To **unlock** the thermostat, press and hold the FAN button for 5 seconds to access the Setup screen (it's the only button that works in the lock mode). Access the Advanced Settings Menu (as above) to turn the Display Lock off.

**Test Mode** Range: Y or N Default: N  
Test mode shortens the system built-in delays (like MOT and MRT)  
Y= Test mode on. Reduces all delays to 10 sec for quicker system testing  
N= Test mode off. Normal system delays

**Aux Heat Enable (Heat Pump Systems only)** Range: Y or N Default: Y  
Enables the Auxiliary Heat operation.  
Typically the Aux Heat will be heat-strips in a Heat Pump system

**2<sup>nd</sup> Stage Heat Enable** Range: Y or N Default: N  
Enables the 2<sup>nd</sup> Stage Heat operation

**2<sup>nd</sup> Stage Cool Enable** Range: Y or N Default: N  
Enables the 2<sup>nd</sup> Stage Cool operation

**Minimum Run Time** Range: 1- 9 Minutes Default: 3  
Sets the Minimum Run Time (MRT) delay before a heating/cooling cycle can turn off.  
Sets heating/cooling cycle time. Prevents rapid on/off cycling.

**Minimum Off Time** Range: 5-9 Minutes Default: 5  
Sets the Minimum Off Time (MOT) delay before another heating/cooling cycle can begin.  
Provides compressor short cycle protection. "WAIT" is displayed on screen when active.

**Heat Setpoint Max** Range: 30F to 109F (0C-43C) Default: 90F (32C)  
Sets the maximum heating setpoint value.  
Will not ramp or accept setpoints higher than this maximum.

**Cool Setpoint Min** Range: 33F to 112F (2C-45C) Default: 60F (15C)  
Sets the minimum cooling setpoint value.  
Will not ramp or accept setpoints lower than this minimum.

**Heat Blower Off Delay** Range: 0-90 seconds Default: 0 (off)  
Sets the system blower delay off time after a heat call ends (fan purge).

**Cool Blower Off Delay** Range: 0-90 seconds Default: 0 (off)  
Sets the system blower delay off time after a cool call ends (fan purge).

**Heat - Cool Delta** Range: 3 - 15 degrees. Default: 3F (1C)  
Sets the minimum separation between heating and cooling setpoints.

**Note!** Attempts to lower the cooling setpoint below the heating setpoint will PUSH the heating setpoint down to maintain this separation. The same applies to setting the heating setpoint above the cooling setpoint, it will PUSH the cooling setpoint up to maintain the setpoint delta separation.

**Heating Stage 1 On Threshold** Range: 1 to 6 degrees Default: 1  
Sets the delta from setpoint that stage 1 heating starts.

**Heating Stage 1 Off Threshold** Range: 0 to 5 degrees Default: 0  
Sets the delta from setpoint that stage 1 heating stops.  
Stage 1 turns off at setpoint + Delta Stage 1.

**Heating Stage 2 On Threshold** Range: 2 to 7 degrees Default: 2

Sets the delta from setpoint that stage 2 heating starts.

**Heating Stage 2 Off Threshold**                      Range: 0 to 6 degrees                      Default: 0  
Sets the delta from setpoint that stage 2 heating stops.  
Stage 2 turns off at setpoint + Delta Stage 2.

**Aux Heat On Threshold**                              Range: 3 to 8 degrees                      Default: 3  
Sets the delta from setpoint that stage 3 heating starts.

**Aux Heat Off Threshold**                              Range: 0 to 7 degrees                      Default: 0  
Sets the delta from setpoint that stage 3 heating stops.  
Stage 3 turns off at setpoint + Delta Stage 3.

**Cooling Stage 1 On Threshold**                      Range: 1 to 7 degrees                      Default: 1  
Sets the delta from setpoint that stage 1 cooling starts.

**Cooling Stage 1 Off Threshold**                      Range: 0 to 6 degrees                      Default: 0  
Sets the delta from setpoint that stage 1 cooling stops.  
Stage 1 turns off at setpoint - Delta Stage 1

**Cooling Stage 2 On Threshold**                      Range: 2 to 8 degrees                      Default: 2  
Sets the delta from setpoint that stage 2 cooling starts.

**Cooling Stage 2 Off Threshold**                      Range: 0 to 7 degrees                      Default: 0  
Sets the delta from setpoint that stage 2 cooling stops.  
Stage 2 turns off at setpoint - Delta Stage 2.

**Restore Defaults**                                      Range: Yes, No                                      Default: No  
Restores all settings to factory defaults.  
Press Yes to restore defaults  
Press No to exit and not restore defaults

## **Z-Wave Installation**

See the Operating Guide for instructions on installing the thermostat on a Z-Wave network.

# Operation Guide

## Model TBZ500 Battery Powered Z-Wave Thermostat

### Main Thermostat Screen

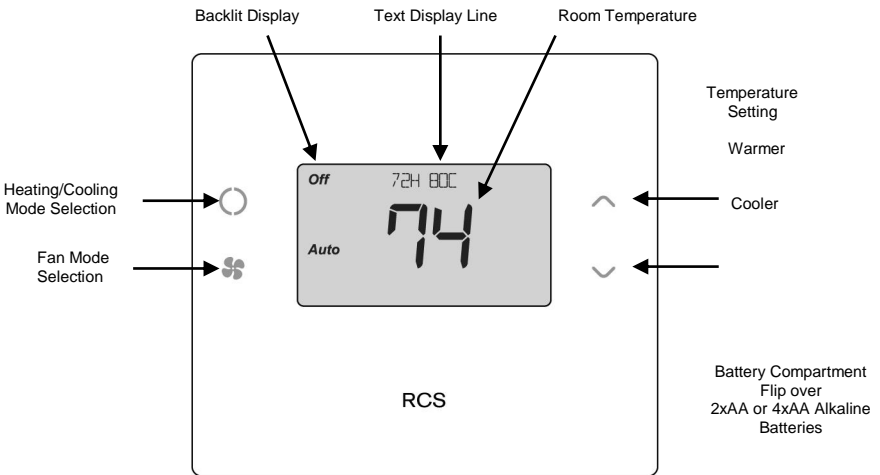

### Backlight and Button Operation

The thermostat backlight is normally set to go out after 20 seconds of no button presses to conserve battery power. **If the backlight is off, the first button press of any button** will only turn on the backlight. Once the backlight is on, the buttons function normally.

### TBZ500 Display

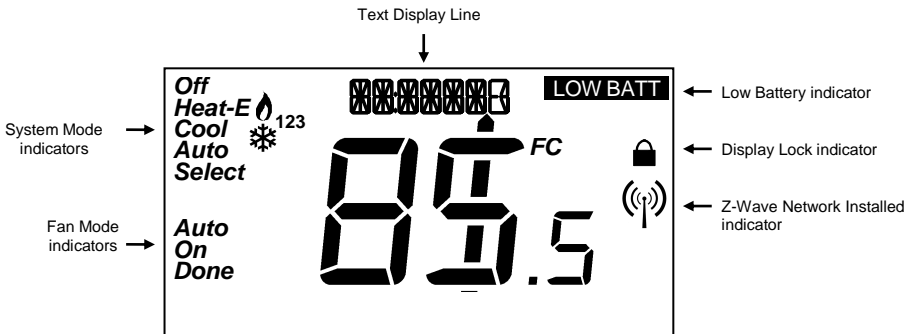

### System Operation Modes

- displayed > System is ON and heating
- displayed > System is ON and cooling

- 🔥 blinking > System is ON and heating. Minimum Run Time (MRT) delay is active.
- ❄️ blinking > System is ON and cooling. Minimum Run Time (MRT) delay is active.

### Staging Indicators

- "1" = Stage 1 heating or cooling is ON
- "2" = Stage 2 heating or cooling is ON
- "3" = Stage 3 heating (Aux Heat) is ON

For Heat Pump systems only:

"Heat-E" = Emergency heat mode active

## Setting the System Mode

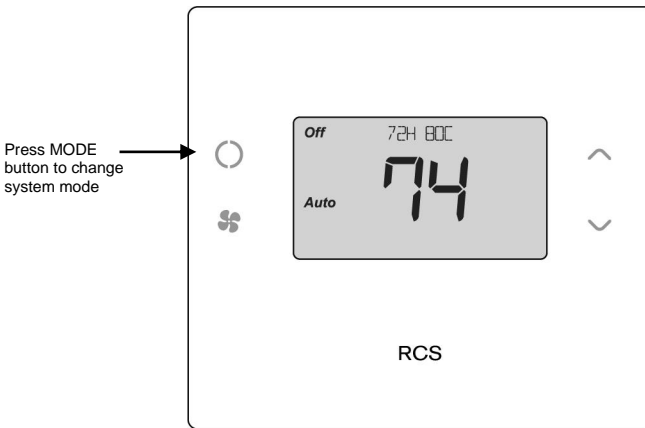

### System Modes

- **Off:** System is off. No heating or cooling will come on. If system was on, it will turn off immediately.
- **Heat:** Only heating will occur.
- **Cool:** Only cooling will occur.
- **Auto:** Heating or cooling will come on according to the heating and cooling setpoints. The system will automatically switch between heating and cooling modes as needed to maintain the setpoints.

### Special Heat Pump Mode: Emergency Heat

- **Heat-E:** An additional system mode, "Heat-E" for Emergency Heat will be displayed if the HVAC System Type is set to Heat Pump. If there is a compressor failure with the Heat Pump system, setting the mode to Emergency Heat will allow the supplemental Aux Heat to come on first whenever there is a call for heating. It also disables the compressor output to prevent further damage to the HVAC system.

**Caution!** *Emergency Heat should only be used for emergencies until the HVAC system can be repaired. Running the system in Emergency Heat mode is commonly the most expensive mode since only the electric heat strips are being used instead of the more efficient heat pump compressor.*

# Setting the Heating or Cooling Temperature Setpoint

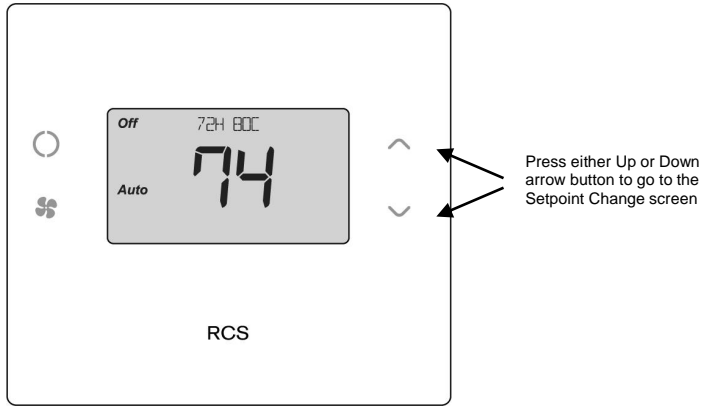

## Setpoint Change screen

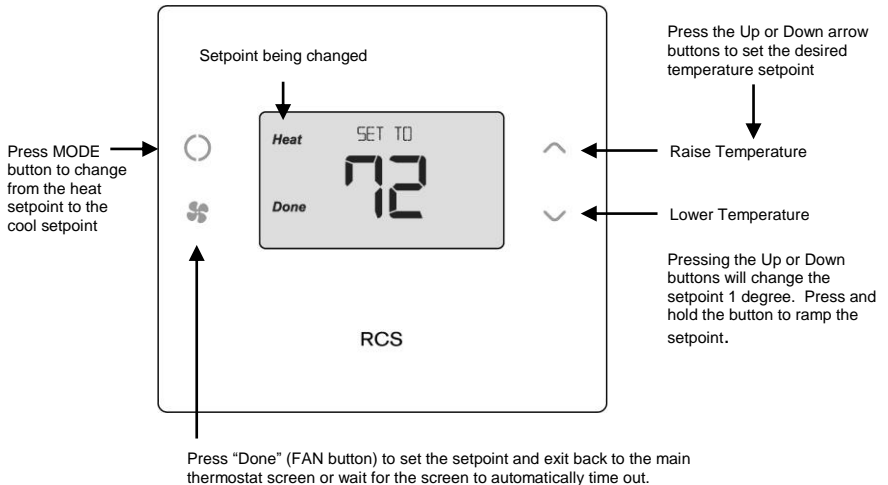

### Setpoint Change

To change the setpoint, press the Up or Down arrow buttons. The screen will switch to the setpoint change screen (as above) and show the current setpoint of the current heating or cooling mode. Adjust setpoint temperature up or down with the arrow buttons.

**Note!** *When in the Setpoint Change screen, pressing the MODE button will switch the setpoint being displayed between the Heat and Cool setpoints.*

**Setpoint Push:** The cooling setpoint cannot be set below the heating setpoint. The thermostat will "push" the heating setpoint lower if the cooling setpoint is set below the current heating setpoint. A 3 degree separation is maintained between the heating and cooling setpoints. The same is true for raising the heating setpoint above the cooling setpoint. The thermostat will "push" the cooling setpoint up to maintain the 3 degree separation.

## Setting the Fan Mode

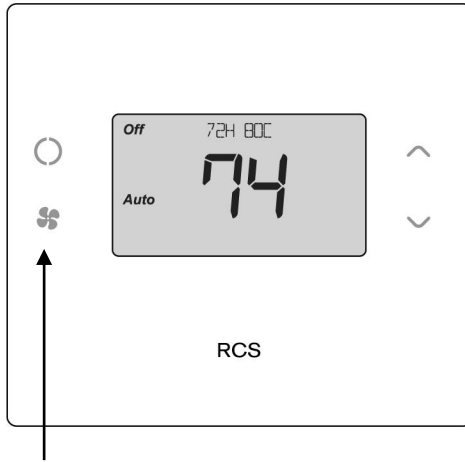

Press the FAN button to change the Fan mode

### Fan Modes:

- **Auto:** Fan automatically operated by the HVAC system. (normal setting)
- **On:** Manual Fan mode. Fan stays on until mode is changed back to Auto, independent of the heating or cooling system operation.

## Thermostat Menu Mode

The Thermostat has a menu of setup and information displays. To change to the Menu Mode, press and hold the FAN button for 5 seconds. The display will change to the Menu Mode and display the Setup screen. Use the Up/Down arrow buttons to scroll through other menu items.

### Thermostat Main Screen

Press and hold the FAN button for 5 seconds to go to the Menu Mode screen

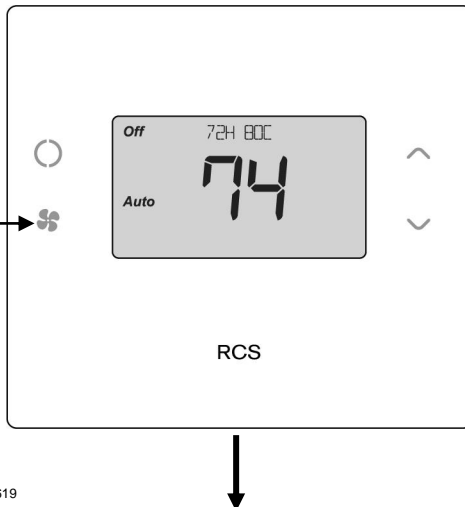

## Menu Mode Screen

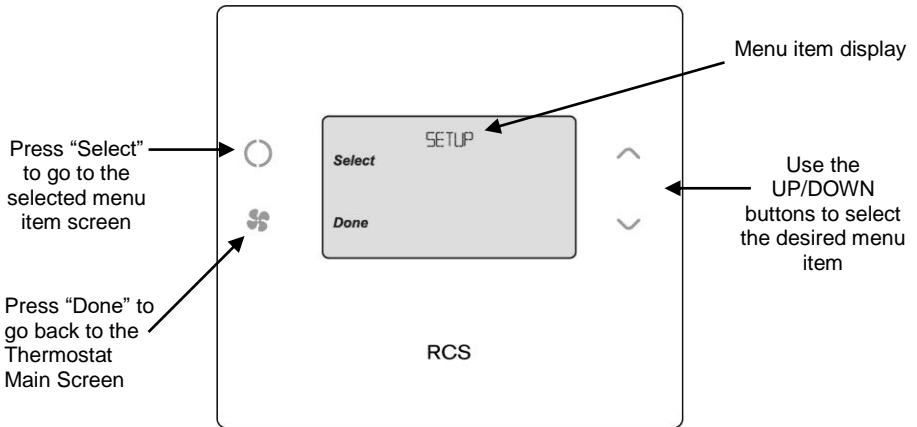

## Menu Mode options

- **SETUP** User preference settings
- **SYSTEM** Thermostat HVAC system settings
- **ZWAVE** Z-Wave network install or remove
- **CLOCK** Setting the thermostat time and day
- **INFO** Displays thermostat version and setup info

## SETUP Menu

User preference settings.

**FAHRENHEIT OR CELSIUS.** Select the temperature display mode.

**BACKLIGHT TIMEOUT.** Sets the time from last button press that the backlight will turn off. Range: 10-30 seconds. Note: long backlight timeouts will reduce battery life.

If the thermostat is powered from 24VAC, the backlight timeout can be set to "0" which will keep the backlight on continuously.

**SENSOR CALIBRATION** Change the temperature calibration by +/- 7 degrees. Use the Up/Dn arrow buttons to change to the desired display temperature.

## SYSTEM Menu

**SYSTEM TYPE.** Select the system type, **STANDARD** or **HEAT PUMP**

**FAN TYPE** (Standard systems only).

Select fan type: **GAS** (typical default setting) or **ELECTRIC**

**CHANGE OVER TYPE** (Heat Pump systems only).

Select the Changeover type:

Changeover **WITH COOL** (typical default setting)

Changeover **WITH HEAT**



See Installation Guide for more information on System setup and the Advanced Systems Menu

## **Z-WAVE Menu**

This menu item allows the thermostat to be enrolled to the Z-Wave network. Follow the instructions shown in the Z-Wave® Operation section (page 19) to enroll the Thermostat onto the network.

## **CLOCK Menu**

Set the time and day of the week.

Press select to set the DAY. The current day of the week setting will be displayed. Press the UP/DN arrows to change the day of the week desired.

Press select to set the TIME. The current time will be displayed. Press the UP/DN arrows to change the time.

## **INFO Menu**

The INFO menu displays information about the thermostat. Use the Up/Dn buttons to scroll through the various items.

Thermostat information displayed:

**VERSION** Thermostat firmware version

**ZWAVE** Z-Wave firmware version

**NODE ID** Z-Wave Node ID

**HOME ID** Z-Wave Home ID

**SYSTEM TYPE** displays current System Type setting (Standard or Heat Pump)

*If System Type = Standard*

**FAN TYPE** displays current Fan Type setting

*If System Type = Heat Pump*

**CHANGEOVER TYPE** displays current Change Over valve (reversing valve) setting

## **Thermostat Operation**

### **Minimum Run Time (MRT)**

The thermostat has a Minimum Run Time (MRT) delay after the start of any heating or cooling call. This minimum run time assures even heating and cooling cycles. The MRT will keep the system on, even if it reaches the setpoint room temperature, or you change the setpoint to a temperature that would satisfy the call, until the MRT expires. Changing the Mode to OFF will cancel the MRT and the system will turn off immediately. The MRT can be adjusted in the Advanced Settings menu of the thermostat.

*Note: The MRT status is shown in the thermostat Status display.*

**Minimum Off Time (MOT)**

The thermostat has a Minimum Off Time (MOT) delay after any heating or cooling cycle ends. This delay prevents rapid heating/cooling cycles and also provides “short cycle protection” for the system compressor. This delay may be noticeable when you change a setpoint and it does not respond immediately due to the MOT delay timer preventing the system from restarting. The MOT delay time can be adjusted in the Advanced Settings menu of the thermostat but there is a minimum of a 5 minute delay to assure compressor protection.

*Note: The MOT status is shown in the thermostat Status display.*

# **Z-Wave® Operation**

**Thermostat Battery Operation:** *If the thermostat is installed in a Z-Wave network while powered by **batteries**, it will be enrolled as a Z-Wave FLiRs type device. This is a power saving mode that conserves the batteries by keeping the radio asleep most of the time. However, in this mode, the thermostat does not act as a repeater/router in the Z-Wave network.*

**Thermostat 24VAC Operation:** *If the thermostat is installed in a Z-Wave network while powered by **24VAC**, it will be enrolled as an always-listening device and can act as a router node in the Z-Wave network.*

**Caution!** *Once installed in a Z-Wave network, if you change how the thermostat is powered (from batteries to 24VAC or vice versa), you must remove and re-enroll the thermostat in the Z-Wave network for it to work correctly.*

## **Adding the thermostat to a Z-Wave network.**

1. Follow the instructions provided with your system for enrolling the thermostat.
2. Press and hold the **FAN button** on the Thermostat until the screen changes to the Menu screen.
3. Press the UP button until ZWAVE is shown in the Status Display line then press Select.
4. INSTALL should be shown on the status line.
5. When instructed by your system installation to add the thermostat to the network press the "Select" button to install. Wait until SUCCESS or FAILED is shown on the status display.
6. Press Done on the Thermostat to exit the ZWAVE screen.
7. Press Done on the Thermostat again to exit the Menu screen.
8. Once enrolled on your system's network, continue to follow the instructions provided to complete the enrollment and naming of the thermostat.
9. The  indicator should be shown on the Thermostat Main screen indicating the thermostat has successfully been enrolled into the Z-Wave network.

## **Removing the thermostat from a Z-Wave network.**

It may be necessary to remove and/or reinstall the thermostat from a Z-Wave network, if the thermostat has been previously installed on another network.

Follow the instructions supplied with your Z-Wave system to remove/uninstall a Z-Wave device. When the system instructs you to press and release the Z-Wave button on the thermostat, follow these steps:

1. Press and hold the FAN button for 3 seconds until the Menu screen is displayed.
2. Press the UP arrow button to scroll to the "ZWAVE" menu.
3. Press "Select" to select the ZWAVE screen.
4. The display will show "REMOVE" in the text line.
5. Press "Select" to perform the remove action.
6. "WAIT" will be displayed in the text line. The remove operation is in process.
7. "SUCCESS" will be display when the reset is completed.
8. Press "Done" to exit back to the thermostat screen.
9. Thermostat is now ready to be added to the wireless network.

# FCC/IC

## INFORMATION TO USER

This device complies with FCC part 15 FCC Rules. Operation is subject to the following two conditions:

1. This device may not cause harmful interference and
2. This device must accept any interference, including interference that may cause undesired operation of the device.

### FCC Warning

Changes or modifications not expressly approved by the party responsible for compliance could void the user's authority to operate the equipment. Note: This equipment has been tested and found to comply with the limits for a Class B digital device, pursuant to part 15 of the FCC Rules. These limits are designed to provide reasonable protection against harmful interference in a residential installation. This equipment generates, uses and can radiate radio frequency energy and, if not installed and used in accordance with the instructions, may cause harmful interference to radio communications. However, there is no guarantee that interference will not occur in a particular installation. If this equipment does cause harmful interference to radio or television reception, which can be determined by turning the equipment off and on, the user is encouraged to try to correct the interference by one or more of the following measures:

- Reorient or relocate the receiving antenna.
- Increase the separation between the equipment and receiver.
- Connect the equipment into an outlet on a circuit different from that to which the receiver is connected.
- Consult the dealer or an experienced radio/TV technician for help.
- This device meets the FCC and IC requirements for RF exposure in public or uncontrolled environments.

This device complies with Industry Canada license-exempt RSS standard(s). Operation is subject to the following two conditions: (1) this device may not cause interference, and (2) this device must accept any interference, including interference that may cause undesired operation of the device.

Cet appareil est conforme avec Industrie Canada RSS standard exempts de licence (s). Son utilisation est soumise à Les deux conditions suivantes:

1. cet appareil ne peut pas provoquer d'interférences et
2. cet appareil doit accepter Toute interférence, y compris les interférences qui peuvent causer un mauvais fonctionnement du dispositif

This Class B digital apparatus complies with Canadian ICES-003.

Cet appareil numérique de la classe B est conforme à la norme NMB-003 du Canada