

# FCC RADIO TEST REPORT

## FCC 47 CFR PART 15 SUBPART C

<b>Test Standard</b>	<b>FCC Part 15.249(a)</b>
<b>FCC ID</b>	<b>WHBFCAREYE20</b>
<b>Trade name</b>	<b>BMW, MINI</b>
<b>Product name</b>	<b>Advanced Car Eye 2.0</b>
<b>Model No.</b>	<b>BMW Advanced Car Eye 2.0, MINI Advanced Car Eye 2.0</b>
<b>Test Result</b>	<b>Pass</b>

The test Result was tested by Compliance Certification Services Inc. The test data, data evaluation, test procedures, and equipment configurations shown in this report were given in ANSI C63.10: 2013 and compliance standards.

The test results of this report relate only to the tested sample (EUT) identified in this report.

The test Report of full or partial shall not copy. Without written approval of Compliance Certification Services Inc.(Wugu Laboratory)



Approved by:

A handwritten signature in black ink that reads 'Sam Chuang'.

Sam Chuang  
Manager

Tested by:

A handwritten signature in black ink that reads 'Kevin.Kuo'.

Kevin Kuo  
Engineer

## Revision History

Rev.	Issue Date	Revisions	Page	Revised By
00	October 19, 2017	Initial Issue	ALL	Allison Chen
01	November 7, 2017	1. Added Test Channel Frequencies. 2. Modify the test frequency.	P.11, P.16	Allison Chen

## **Table of contents**

<b>1. GENERAL INFORMATION .....</b>	<b>4</b>
1.1 EUT INFORMATION .....	4
1.2 EUT CHANNEL INFORMATION .....	5
1.3 ANTENNA INFORMATION .....	5
1.4 MEASUREMENT UNCERTAINTY.....	6
1.5 FACILITIES AND TEST LOCATION.....	7
1.6 INSTRUMENT CALIBRATION .....	7
1.7 SUPPORT AND EUT ACCESSORIES EQUIPMENT .....	8
<b>2. TEST SUMMERY .....</b>	<b>9</b>
<b>3. DESCRIPTION OF TEST MODES .....</b>	<b>10</b>
3.1 THE WORST MODE OF MEASUREMENT .....	10
<b>4. TEST RESULT .....</b>	<b>11</b>
4.1 FIELD STRENGTH OF FUNDAMENTAL AND SPURIOUS EMISSION .....	11
<b>APPENDIX 1 - PHOTOGRAPHS OF EUT</b>	

# 1. GENERAL INFORMATION

## 1.1 EUT INFORMATION

Applicant	Mobile Appliance, Inc. Gwanyang-dong-1701~1706, Daerung Techno #15, 401, Simin-daero, Dongan-gu, Anyang-si, Gyeonggi-do, Korea
Equipment	Advanced Car Eye 2.0
Model Name	BMW Advanced Car Eye 2.0, MINI Advanced Car Eye 2.0
Model Discrepancy	The two model names are difference from trade name, just for marketing purpose only.
EUT Functions	24G Radar
Received Date	September 4, 2017
Date of Test	October 16 ~ October 19, 2017
Output Power	Peak : 103.48dBuV/m Average : 90.96dBuV/m
Power Operation	<input type="checkbox"/> AC <input checked="" type="checkbox"/> DC Type : <input type="checkbox"/> Battery <input checked="" type="checkbox"/> DC Power Supply : 12V <input type="checkbox"/> External DC adapter

## 1.2 EUT CHANNEL INFORMATION

Frequency Range	24.00GHz-24.25GHz
Modulation Type	CW
Number of channel	1

## 1.3 ANTENNA INFORMATION

Antenna Type	<input type="checkbox"/> PIFA <input checked="" type="checkbox"/> PCB <input type="checkbox"/> Dipole <input type="checkbox"/> Printed <input type="checkbox"/> Coils
Antenna Gain	9.5 dBi

## 1.4 MEASUREMENT UNCERTAINTY

PARAMETER	UNCERTAINTY
AC Powerline Conducted Emission	N/A
Emission bandwidth, 20dB bandwidth	+/- 1.4003
RF output power, conducted	+/- 1.1372
Power density, conducted	+/- 1.4003
3M Semi Anechoic Chamber / 30M~200M	+/- 4.0138
3M Semi Anechoic Chamber / 200M~1000M	+/- 3.9483
3M Semi Anechoic Chamber / 1G~8G	+/- 2.5975
3M Semi Anechoic Chamber / 8G~18G	+/- 2.6112
3M Semi Anechoic Chamber / 18G~26G	+/- 2.7389
3M Semi Anechoic Chamber / 26G~40G	+/- 2.9683
3M Semi Anechoic Chamber / 40G~60G	+/- 1.8509
3M Semi Anechoic Chamber / 60G~75G	+/- 1.9869
3M Semi Anechoic Chamber / 75G~110G	+/- 2.9651
3M Semi Anechoic Chamber / 110G~170G	+/- 2.7807
3M Semi Anechoic Chamber / 170G~220G	+/- 3.6437
3M Semi Anechoic Chamber / 220G~325G	+/- 4.2982

**Remark:**

1. This uncertainty represents an expanded uncertainty expressed at approximately the 95% confidence level using a coverage factor of  $k=2$
2. ISO/IEC 17025 requires that an estimate of the measurement uncertainties associated with the emissions test results be included in the report.

## 1.5 FACILITIES AND TEST LOCATION

All measurement facilities used to collect the measurement data are located at No.11, Wugong 6th Rd., Wugu Dist., New Taipei City 24891, Taiwan. (R.O.C.)

Test site	Test Engineer	Remark
AC Conduction Room	-	-
Radiation	Kevin Kuo	-
RF Conducted	Kevin Kuo	-

**Remark:** The sites are constructed in conformance with the requirements of ANSI C63.7, ANSI C63.4 and CISPR Publication 22.

## 1.6 INSTRUMENT CALIBRATION

3M 966A Chamber Test Site					
Name of Equipment	Manufacturer	Model	Serial Number	Cal Date	Cal Due
Bilog Antenna	Sunol Sciences	JB3	A030105	06/20/2017	06/19/2018
Horn Antenna	EMCO	3117	00055165	02/20/2017	02/19/2018
Horn Antenna	Schwarzbeck	BBHA 9170	N/A	04/13/2017	04/12/2018
K Type Cable	Huber+Suhner	SUCOFLEX 102	29406/2	01/10/2017	01/09/2018
K Type Cable	Huber+Suhner	SUCOFLEX 102	22470/2	01/10/2017	01/09/2018
Pre-Amplifier	EMCI	EMC 012635	980151	08/01/2017	07/31/2018
Pre-Amplifier	EMEC	EM330	060609	06/07/2017	06/06/2018
Pre-Amplifier	COM-POWER	PAM-840A	461310	04/12/2017	04/11/2018
Spectrum Analyzer	Agilent	E4446A	US42510252	12/05/2016	12/04/2017
Antenna Tower	CCS	CC-A-1F	N/A	N.C.R	N.C.R
Controller	CCS	CC-C-1F	N/A	N.C.R	N.C.R
Turn Table	CCS	CC-T-1F	N/A	N.C.R	N.C.R

**Remark:** Each piece of equipment is scheduled for calibration once a year and harmonic mixer twice a year.

## 1.7 SUPPORT AND EUT ACCESSORIES EQUIPMENT

EUT Accessories Equipment					
No.	Equipment	Brand	Model	Series No.	FCC ID
	N/A				

Support Equipment					
No.	Equipment	Brand	Model	Series No.	FCC ID
1	DC Power Source	GWINSTEK	SPS-3610	N/A	N/A

## 1.8 TEST METHODOLOGY AND APPLIED STANDARDS

The test methodology, setups and results comply with all requirements in accordance with ANSI C63.10:2013, FCC Part 15.249.



## 2. TEST SUMMERY

<b>FCC Standard Section</b>	<b>Report Section</b>	<b>Test Item</b>	<b>Result</b>
15.203	1.2	Antenna Requirement	Pass
15.249(a)	4.1	Filed strength of fundamental	Pass
15.249(a)	4.1	Radiation Spurious Emission	Pass

### 3. DESCRIPTION OF TEST MODES

#### 3.1 THE WORST MODE OF MEASUREMENT

Radiated Emission Measurement Above 1G	
Test Condition	Band edge, Emission for Unwanted and Fundamental
DC Voltage	12 V
Test Mode	Mode 1:EUT power by DC source.
Worst Mode	<input checked="" type="checkbox"/> Mode 1 <input type="checkbox"/> Mode 2 <input type="checkbox"/> Mode 3 <input type="checkbox"/> Mode 4
Worst Position	<input type="checkbox"/> Placed in fixed position. <input checked="" type="checkbox"/> Placed in fixed position at X-Plane (E2-Plane) <input type="checkbox"/> Placed in fixed position at Y-Plane (E1-Plane) <input type="checkbox"/> Placed in fixed position at Z-Plane (H-Plane)
Worst Polarity	<input type="checkbox"/> Horizontal <input checked="" type="checkbox"/> Vertical

Radiated Emission Measurement Below 1G	
Test Condition	Radiated Emission Below 1G
DC Voltage	12 V
Test Mode	Mode 1:EUT power by DC source.
Worst Mode	<input checked="" type="checkbox"/> Mode 1 <input type="checkbox"/> Mode 2 <input type="checkbox"/> Mode 3 <input type="checkbox"/> Mode 4

Test Channel Frequencies	
Operation mode	24GHz
Test Channel Frequencies	24.08GHz

*Remark:*

1. The worst mode was record in this test report.
2. EUT pre-scanned in three axis ,X,Y, Z and two polarity, Horizontal and Vertical for radiated measurement. The worst case(X-Plane and Vertical) were recorded in this report

## 4. TEST RESULT

### 4.1 FIELD STRENGTH OF FUNDAMENTAL AND SPURIOUS EMISSION

#### 4.1.1 Test Limit

According to §15.249(a)

(1) The field strength of emissions from intentional radiators operated within these frequency bands shall comply with the following:

Fundamental frequency (MHz)	Field strength of fundamental (millivolts/meter)	Field strength of harmonics (microvolts/meter)
2400-2483.5	50	500
5725-5875	50	500
24000-24250	250	2500

\* Field strength limits are specified at a distance of 3 meters

Fundamental Limit Conversion			
Average (mV/m) at 3M	Average (dBuV/m) at 3M	Average (dBuV/m) at 1M	Peak (dBuV/m) at 1M
250	107.9588	117.50	137.50

\*(Limit=107.9588+20LOG(3/1)=117.50 dBuV/m)

Harmonic Limit Conversion			
Average (uV/m) at 3M	Average (dBuV/m) at 3M	Average (dBuV/m) at 1M	Peak (dBuV/m) at 1M
2500	67.9588	77.50	97.50

\*(Limit=67.9588+20LOG(3/1)=77.50 dBuV/m)

(2) Emissions radiated outside of the specified frequency bands, except for harmonics, shall be attenuated by at least 50 dB below the level of the fundamental or to the general radiated emission limits in §15.209(follow the table), whichever is the lesser attenuation

**Below 30 MHz**

Frequency	Field Strength (microvolts/m)	Magnetic H-Field (microamperes/m)	Measurement Distance (metres)
9-490 kHz	2,400/F (F in kHz)	2,400/F (F in kHz)	300
490-1,705 kHz	24,000/F (F in kHz)	24,000/F (F in kHz)	30
1.705-30 MHz	30	N/A	30

**Above 30 MHz**

Frequency (MHz)	Field Strength microvolts/m at 3 metres (watts, e.i.r.p.)	
	Transmitters	Receivers
30-88	100 (3 nW)	100 (3 nW)
88-216	150 (6.8 nW)	150 (6.8 nW)
216-960	200 (12 nW)	200 (12 nW)
Above 960	500 (75 nW)	500 (75 nW)

**4.1.2 Test Procedure**

1. The EUT is placed on a turntable, Above 1 GHz is 1.5m, below 1 GHz and above 40G is 0.8m above ground plane. The EUT Configured un accordance with ANSI C63.10, and the EUT set in a continuous mode.

2. The turntable shall be rotated for 360 degrees to determine the position of maximum emission level. And EUT is set 3m away from the receiving antenna, which is scanned from 1m to 4m above the ground plane to find out the highest emissions. Measurement are made polarized in both the vertical and the horizontal positions with antenna.

3. The SA setting following :

(1) Below 1G : RBW = 100kHz, VBW ≥ 3 RBW, Sweep = Auto, Detector = Peak,

(2) Above 1G :

(2.1) For Peak measurement : RBW = 1MHz, VBW ≥ 3 RBW.

(2.2) For Average measurement : RBW = 1MHz, VBW = 10Hz.

### 4.1.3 Test Setup

#### 9kHz ~ 30MHz

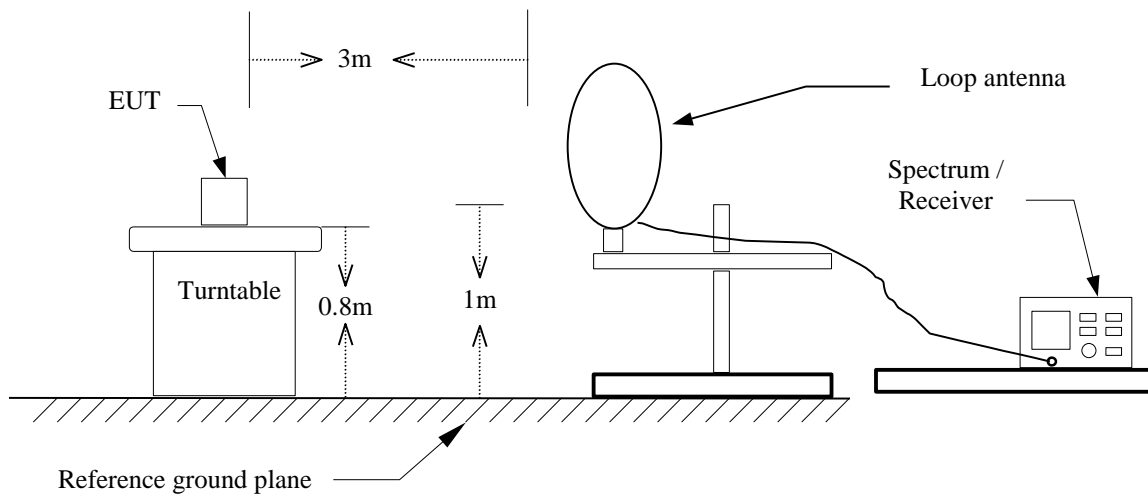

#### 30MHz ~ 1GHz

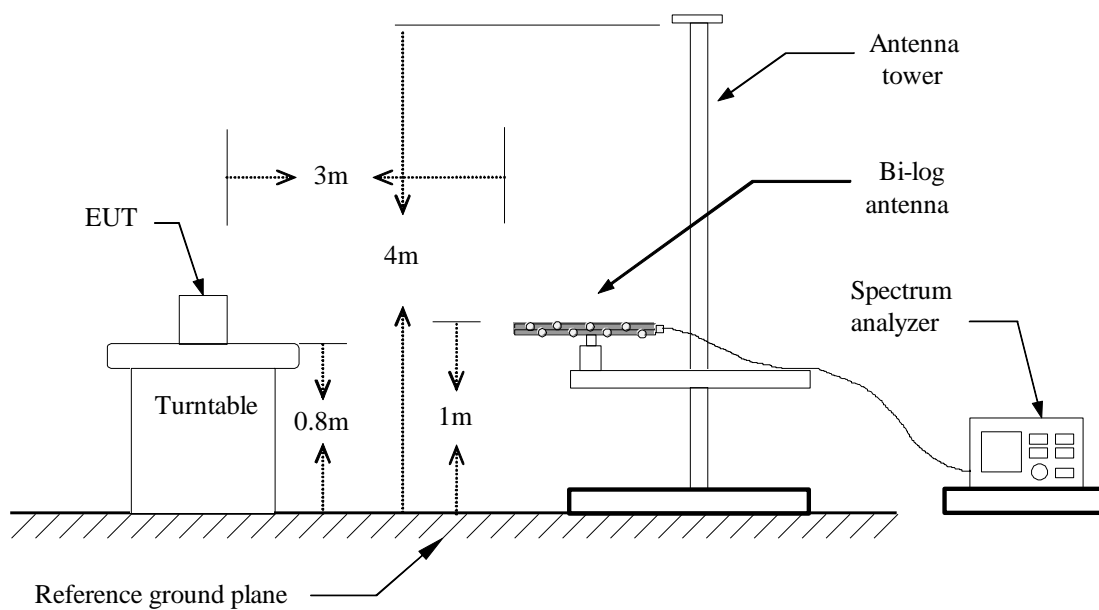

**Above 1 GHz**

**(1-18GHz)**

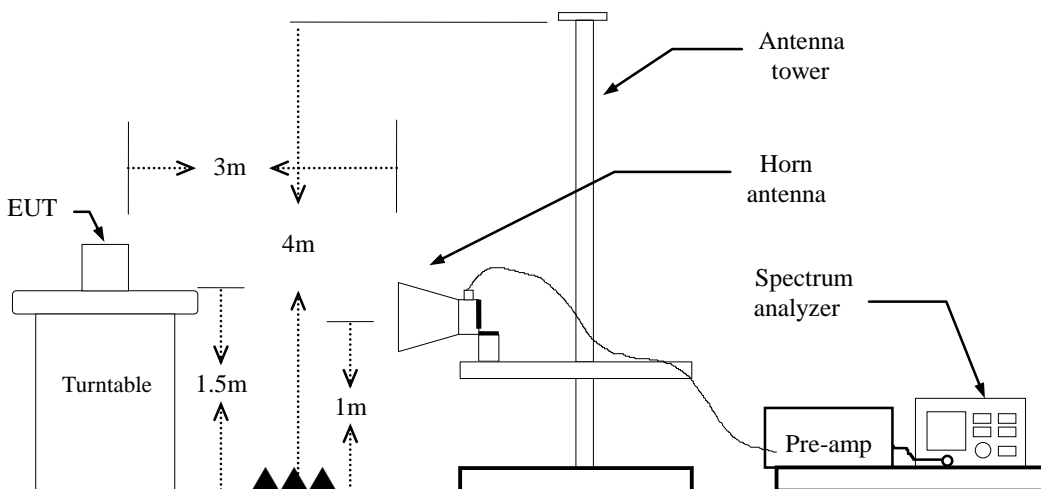

**(18-40GHz)**

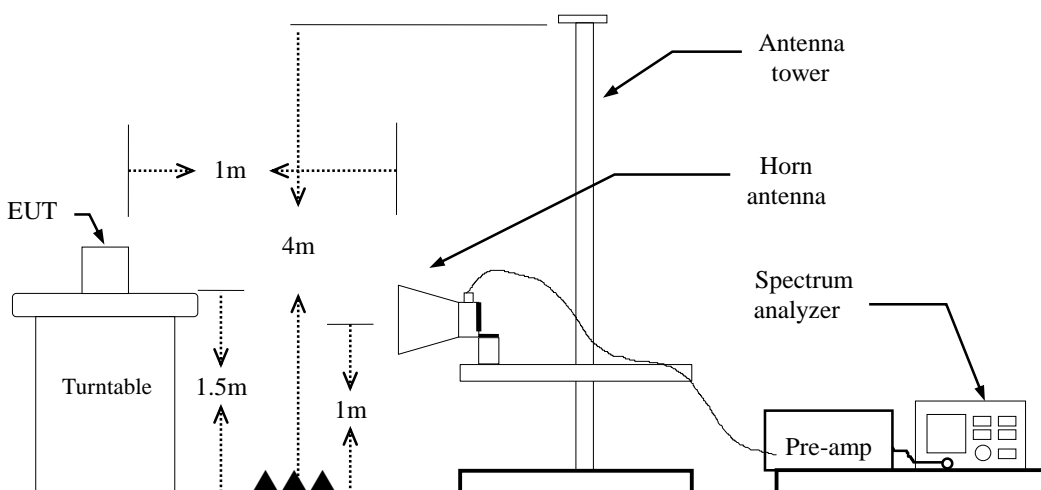

**A83Above 40 GHz**

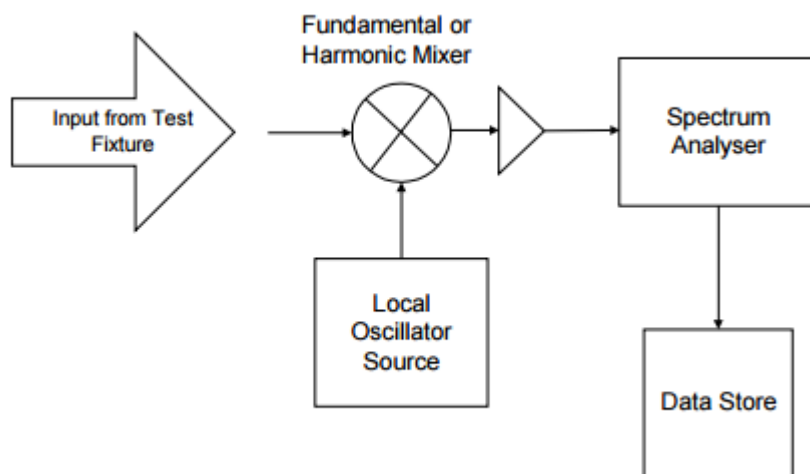

### 4.1.4 Test Result

Freq. (GHz)	Peak Value (dBuV/m)	Average Value (dBuV/m)	Peak Limit (dBuV/m)	Average Limit (dBuV/m)	Result
24.08	103.48	90.96	137.50	117.50	Pass

#### Test Data

##### (1) Filed strength of fundamental :

Test Mode:	TX-24GHz	Temp/Hum	24(°C)/ 33%RH
Test Item	Fundamental	Test Date	October 16, 2017
Axis	X-Plane	Test Engineer	Kevin Kuo
Detector	Peak	Test Voltage:	12Vdc

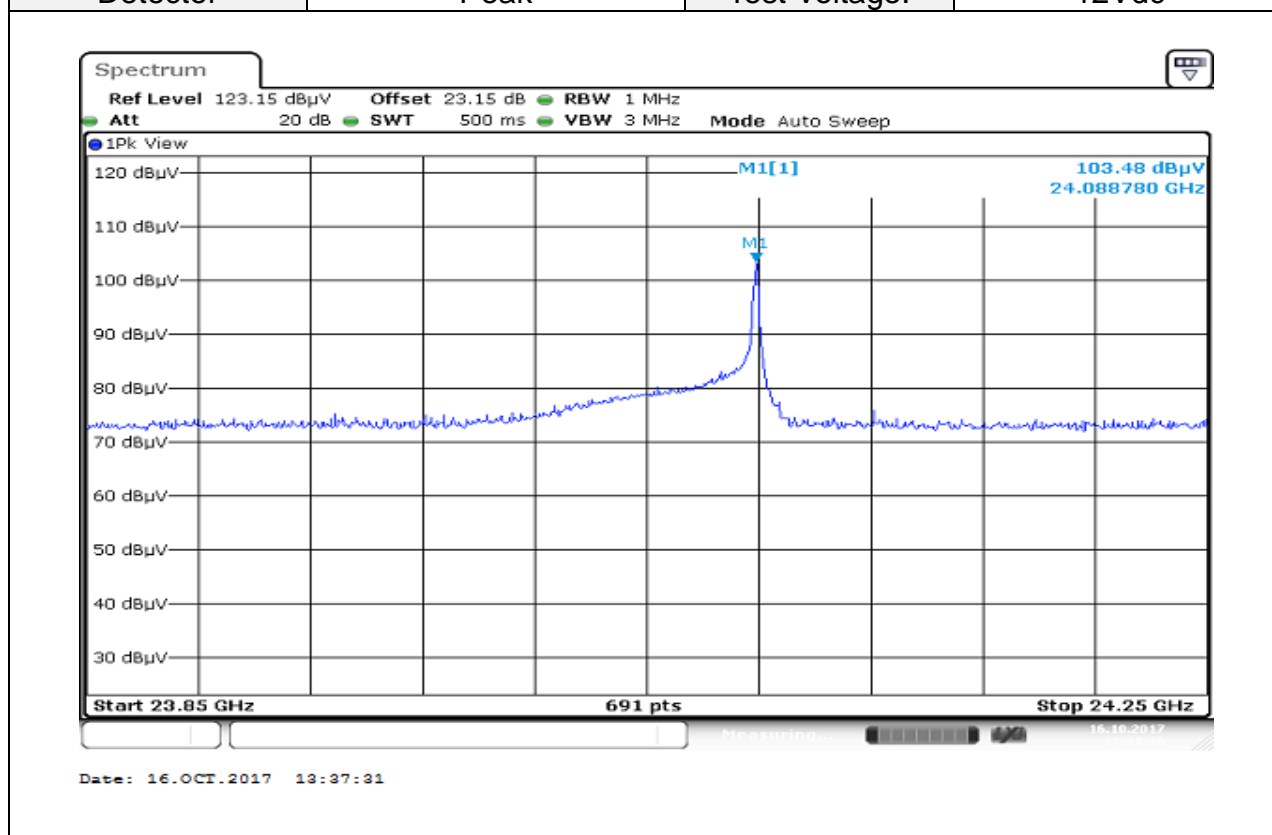



Test Mode:	TX-24GHz	Temp/Hum	24(°C)/ 33%RH
Test Item	Fundamental	Test Date	October 16, 2017
Polarize	Vertical	Test Engineer	Kevin Kuo
Detector	Average	Test Voltage:	12Vdc

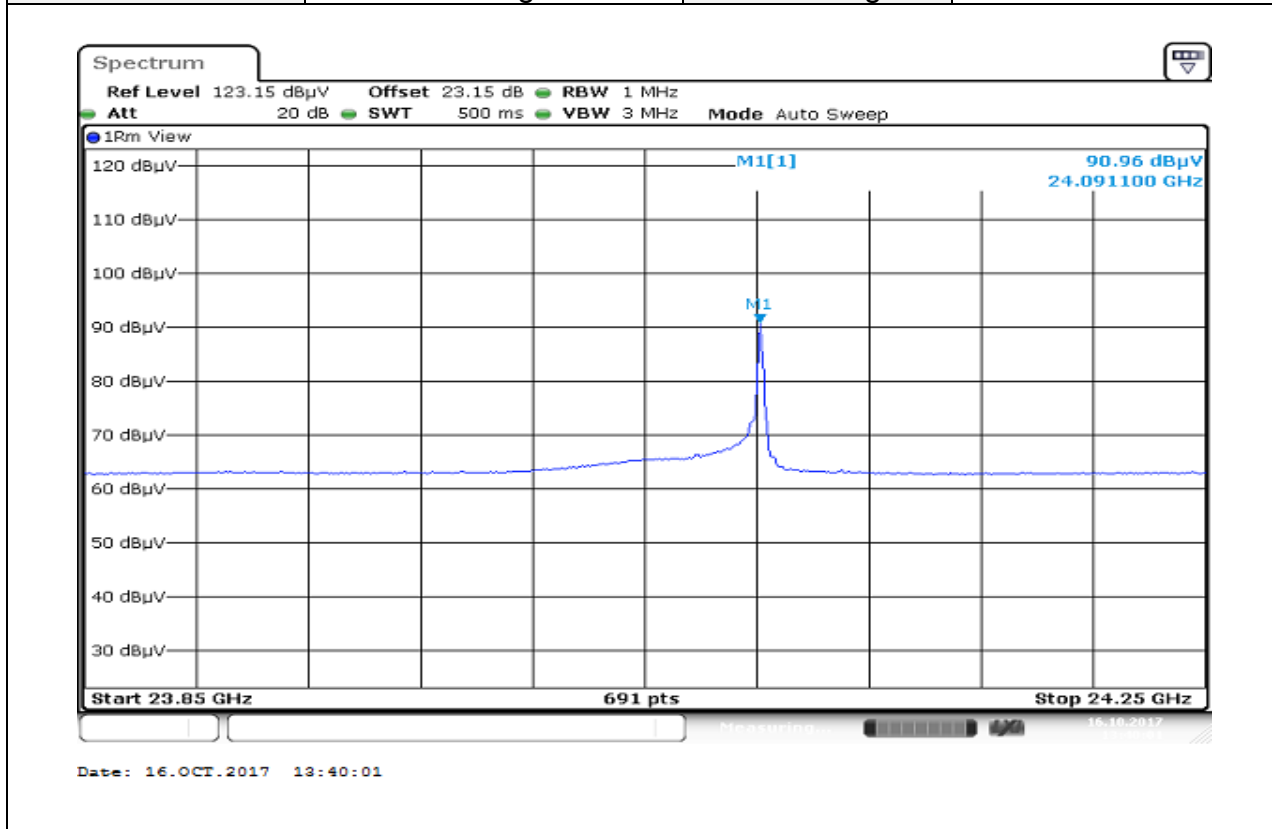

**(2) Below 1G :**

Test Mode:	TX-24GHz	Temp/Hum	24(°C)/ 33%RH
Test Item	30MHz-1GHz	Test Date	October 16, 2017
Polarize	Vertical	Test Engineer	Jerry Chuang
Detector	Peak and Qusi-peak	Test Voltage:	12Vdc

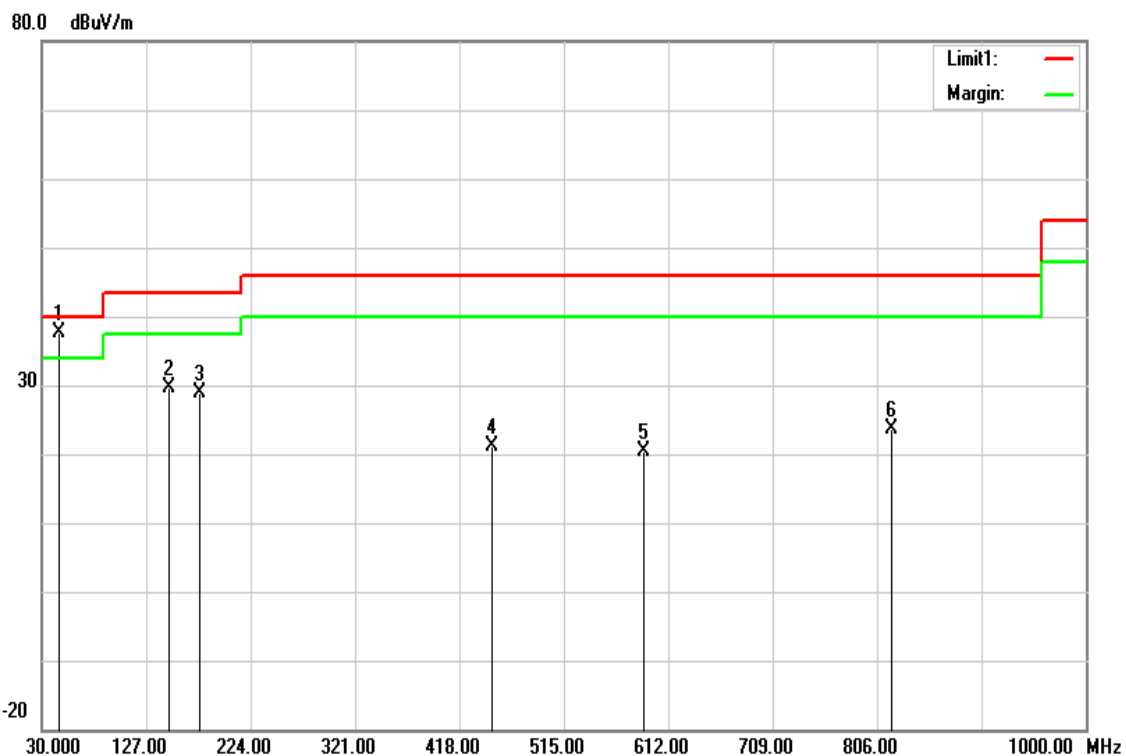

Frequency (MHz)	Reading (dBuV)	Correct Factor (dB/m)	Result (dBuV/m)	Limit (dBuV/m)	Margin (dB)	Remark
46.4900	57.22	-19.69	37.53	40.00	-2.47	QP
148.3400	45.26	-15.72	29.54	43.50	-13.96	peak
176.4700	45.87	-16.94	28.93	43.50	-14.57	peak
448.0700	30.89	-9.67	21.22	46.00	-24.78	peak
589.6900	27.38	-7.06	20.32	46.00	-25.68	peak
819.5800	26.82	-3.17	23.65	46.00	-22.35	peak

Test Mode:	TX-24GHz	Temp/Hum	24(°C)/ 33%RH
Test Item	30MHz-1GHz	Test Date	October 16, 2017
Polarize	Horizontal	Test Engineer	Jerry Chuang
Detector	Peak and Qusi-peak	Test Voltage:	12Vdc

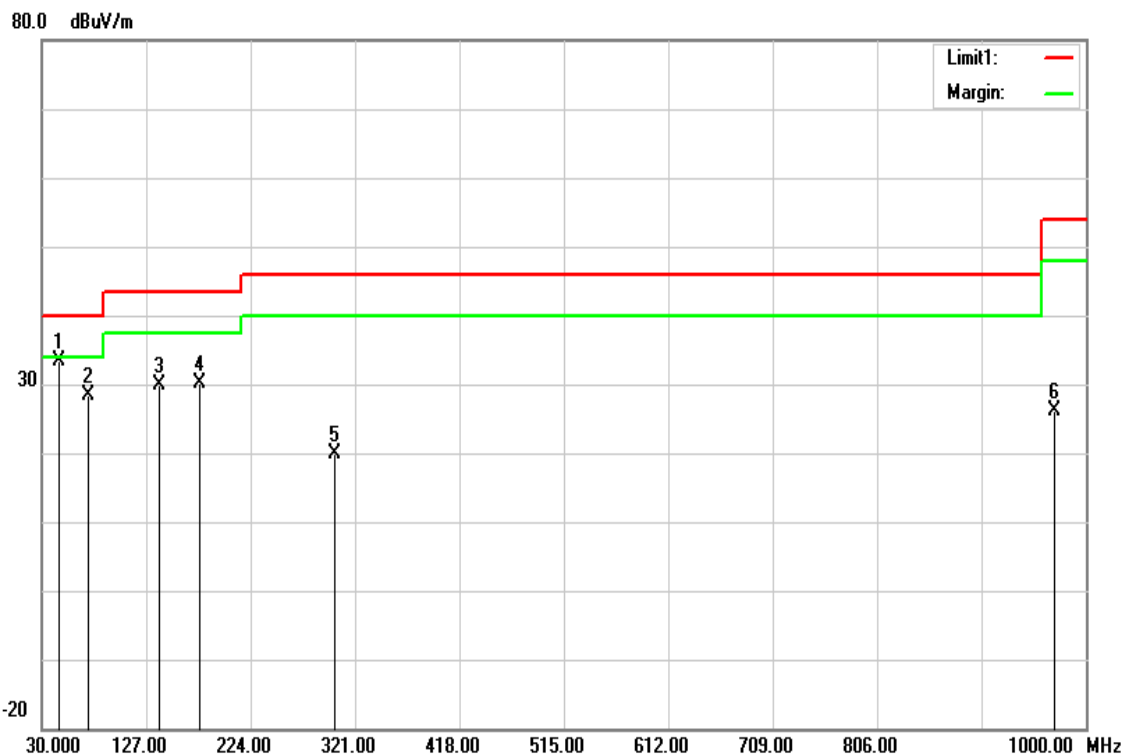

Frequency (MHz)	Reading (dBuV)	Correct Factor (dB/m)	Result (dBuV/m)	Limit (dBuV/m)	Margin (dB)	Remark
46.4900	53.10	-19.69	33.41	40.00	-6.59	peak
72.6800	49.66	-21.31	28.35	40.00	-11.65	peak
139.6100	45.49	-15.53	29.96	43.50	-13.54	peak
176.4700	47.15	-16.94	30.21	43.50	-13.29	peak
302.5700	34.02	-14.02	20.00	46.00	-26.00	peak
970.9000	27.21	-0.96	26.25	54.00	-27.75	peak

**(2) Above 1G :**

Test Mode:	TX-24GHz	Temp/Hum	24(°C)/ 33%RH
Test Item	1GHz-18GHz	Test Date	October 19, 2017
Polarize	Vertical	Test Engineer	Jerry Chuang
Detector	Peak and Average	Test Voltage:	12Vdc

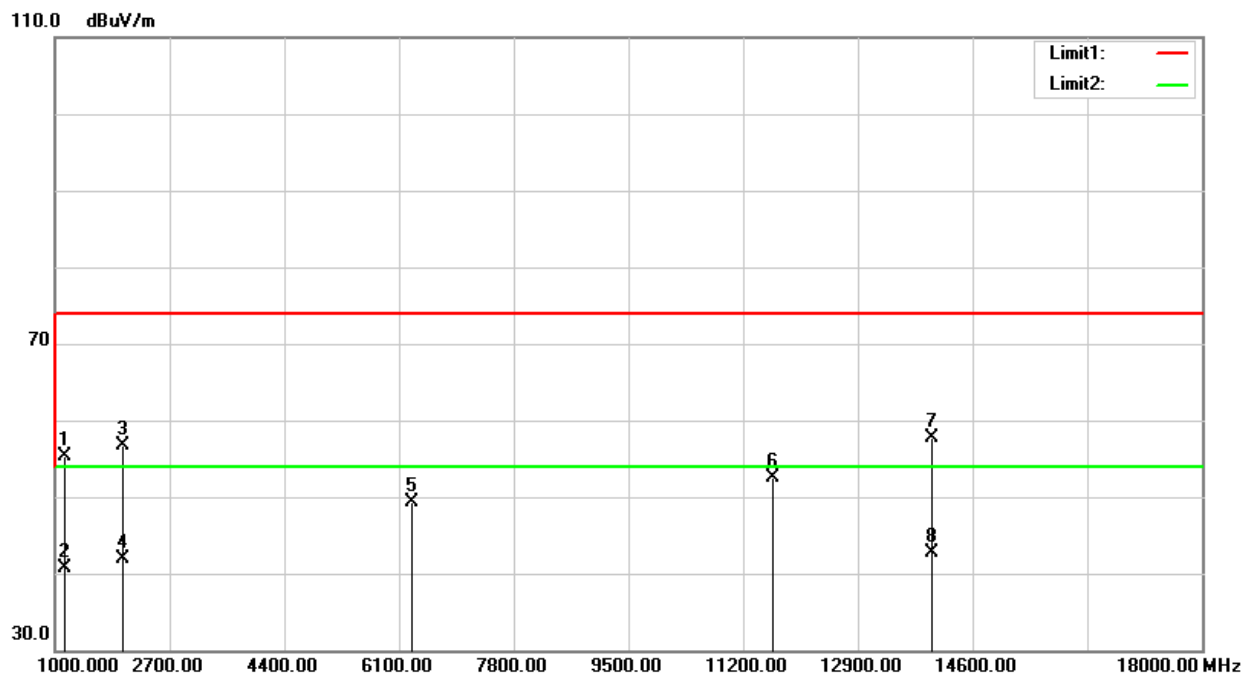

Frequency (MHz)	Reading (dBuV)	Correct Factor (dB/m)	Result (dBuV/m)	Limit (dBuV/m)	Margin (dB)	Remark
1140.000	61.25	-5.98	55.27	74.00	-18.73	peak
1140.000	46.65	-5.98	40.67	54.00	-13.33	AVG
2008.000	58.42	-1.81	56.61	74.00	-17.39	peak
2008.000	43.68	-1.81	41.87	54.00	-12.13	AVG
6299.000	38.12	11.11	49.23	74.00	-24.77	peak
11640.000	33.00	19.58	52.58	74.00	-21.42	peak
13990.000	34.53	23.27	57.80	74.00	-16.20	peak
13990.000	19.43	23.27	42.70	54.00	-11.30	AVG

**Remark:**

1. Measuring frequencies from 1 GHz to the 10th harmonic of highest fundamental frequency.

Test Mode:	TX-24GHz	Temp/Hum	24(°C)/ 33%RH
Test Item	18GHz-40GHz	Test Date	October 19, 2017
Polarize	Vertical	Test Engineer	Jerry Chuang
Detector	Peak and Average	Test Voltage:	12Vdc

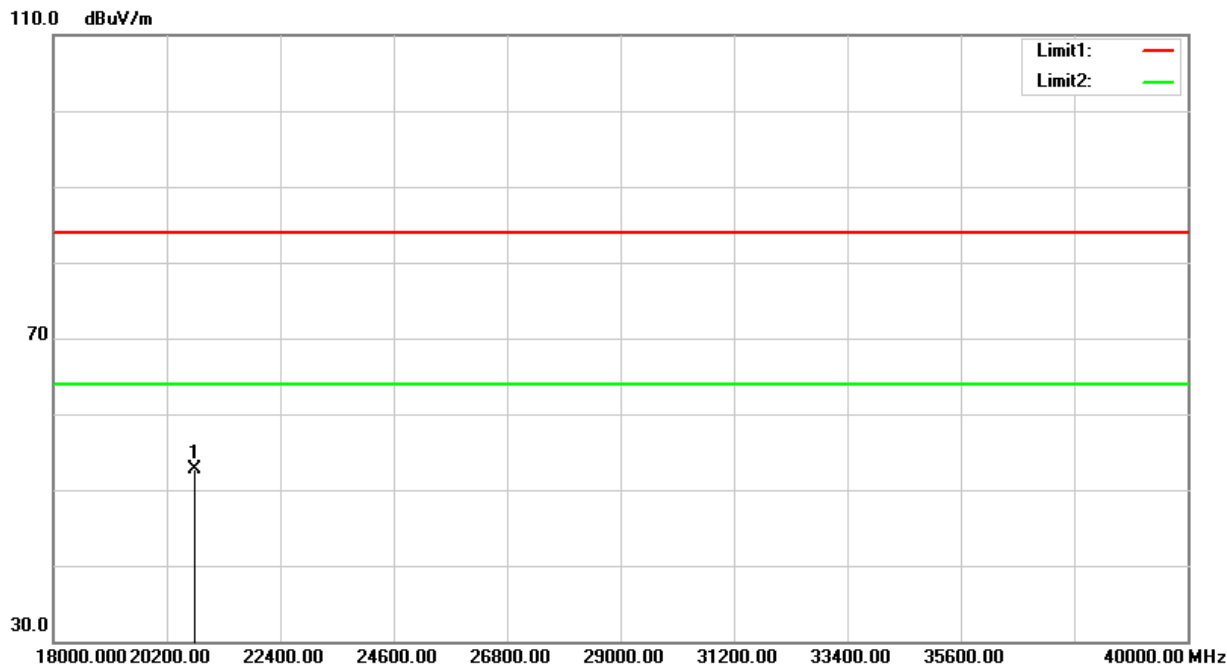

Frequency (MHz)	Reading (dBuV)	Correct Factor (dB/m)	Result (dBuV/m)	Limit (dBuV/m)	Margin (dB)	Remark
20756.000	36.27	16.44	52.71	84.00	-31.29	peak

**Remark:**

1. Measuring frequencies from 1 GHz to the 10th harmonic of highest fundamental frequency.
2. For above 1GHz, the EUT peak value was under average limit, therefore the Average value compliance with the average limit

Test Mode:	TX-24GHz	Temp/Hum	24(°C)/ 33%RH
Test Item	1GHz-18GHz	Test Date	October 19, 2017
Polarize	Horizontal	Test Engineer	Jerry Chuang
Detector	Peak and Average	Test Voltage:	12Vdc

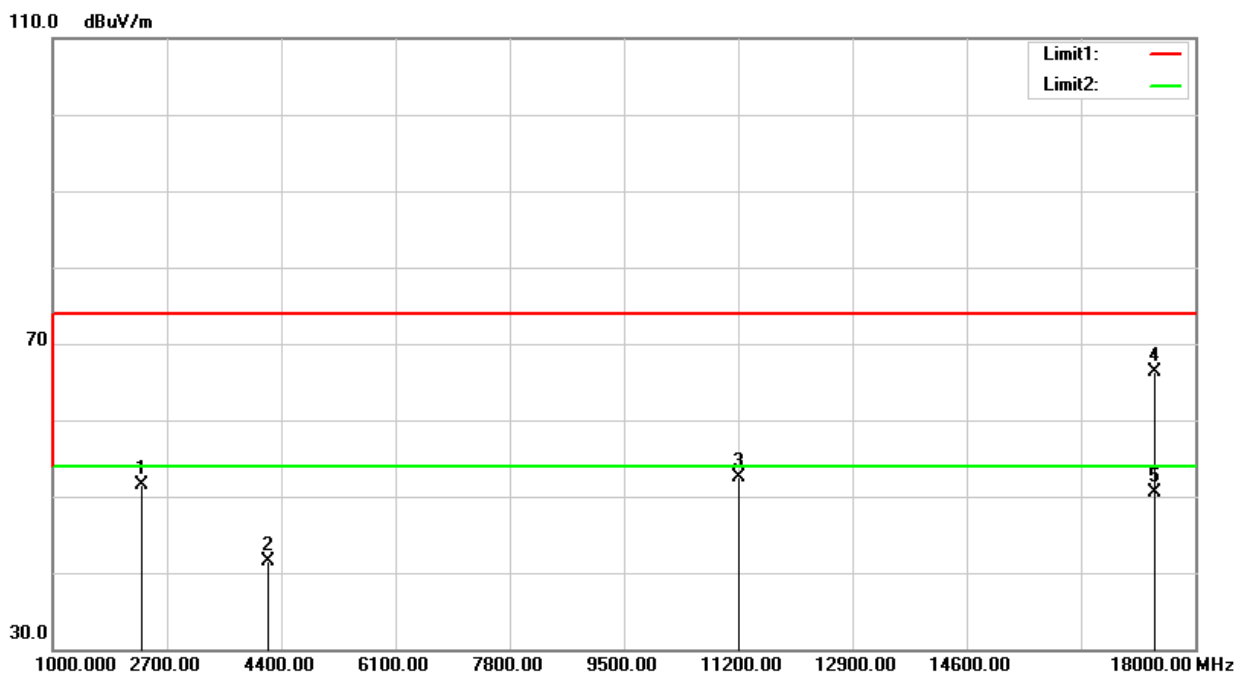

Frequency (MHz)	Reading (dBuV)	Correct Factor (dB/m)	Result (dBuV/m)	Limit (dBuV/m)	Margin (dB)	Remark
2323.000	52.41	-0.81	51.60	74.00	-22.40	peak
4206.000	36.37	5.06	41.43	74.00	-32.57	peak
11210.000	32.86	19.55	52.41	74.00	-21.59	peak
17410.000	34.47	31.83	66.30	74.00	-7.70	peak
17410.000	18.61	31.83	50.44	54.00	-3.56	AVG

**Remark:**

1. Measuring frequencies from 1 GHz to the 10th harmonic of highest fundamental frequency.

Test Mode:	TX-24GHz	Temp/Hum	24(°C)/ 33%RH
Test Item	18GHz-40GHz	Test Date	October 19, 2017
Polarize	Horizontal	Test Engineer	Jerry Chuang
Detector	Peak and Average	Test Voltage:	12Vdc

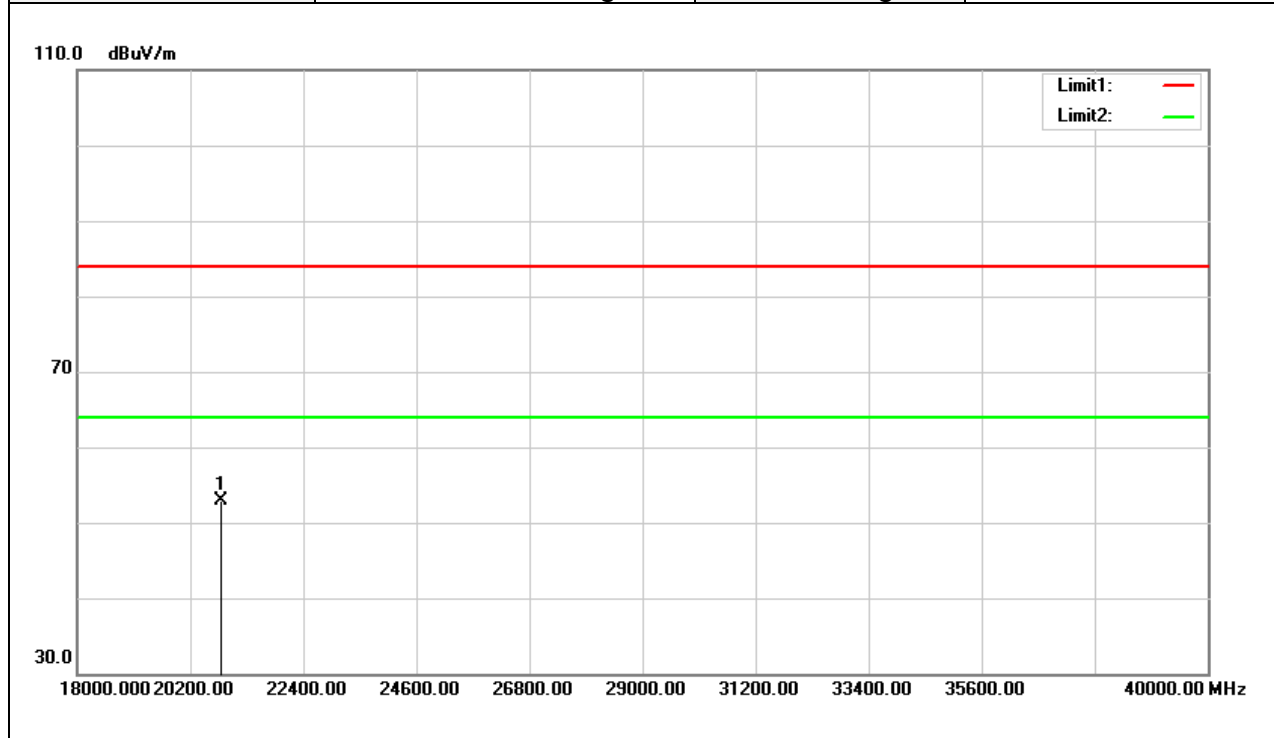

Frequency (MHz)	Reading (dBuV)	Correct Factor (dB/m)	Result (dBuV/m)	Limit (dBuV/m)	Margin (dB)	Remark
20804.000	21.71	31.22	52.93	84.00	-31.07	peak

**Remark:**

1. Measuring frequencies from 1 GHz to the 10th harmonic of highest fundamental frequency.
2. For above 1GHz, the EUT peak value was under average limit, therefore the Average value compliance with the average limit

Test Mode:	TX-24GHz	Temp/Hum	24(°C)/ 33%RH
Test Item	40GHz-60GHz	Test Date	October 16, 2017
Polarize	Vertical/Horizontal	Test Engineer	Kevin Kuo
Detector	Peak and Average	Test Voltage:	12Vdc

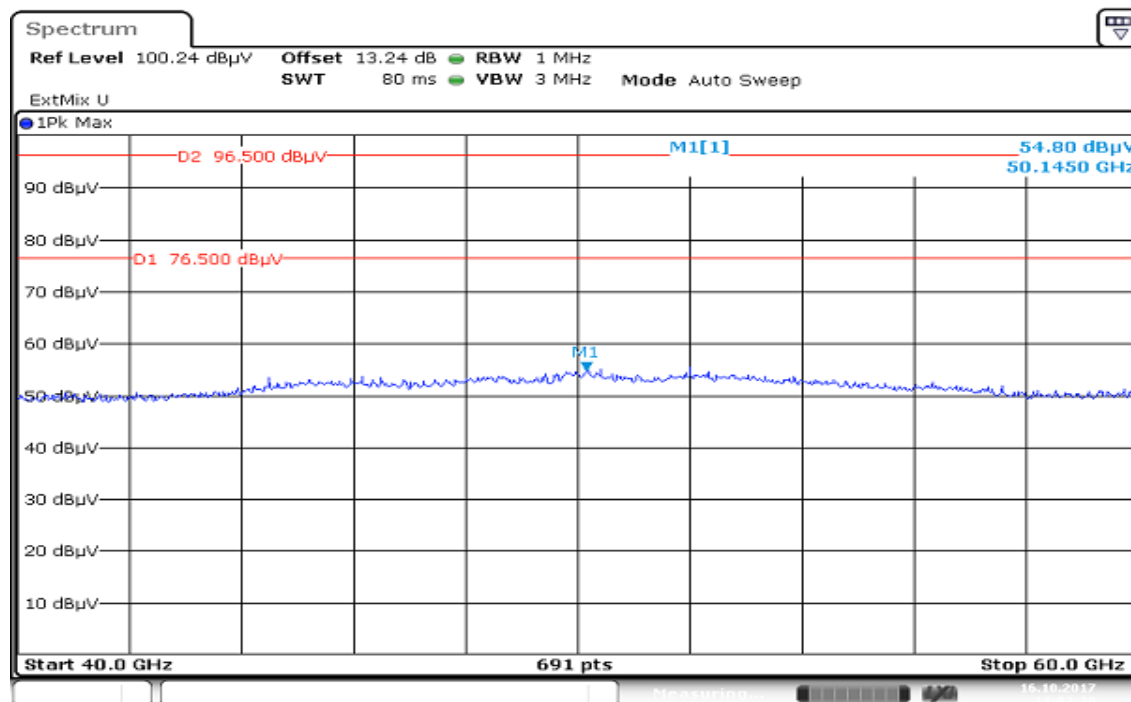

Date: 16.OCT.2017 14:03:30

**Remark:**

1. Measuring frequencies from 1 GHz to the 10th harmonic of highest fundamental frequency.
2. For above 1GHz, the EUT peak value was under average limit, therefore the Average value compliance with the average limit



Test Mode:	TX-24GHz	Temp/Hum	24(°C)/ 33%RH
Test Item	60GHz-75GHz	Test Date	October 16, 2017
Polarize	Vertical/Horizontal	Test Engineer	Kevin Kuo
Detector	Peak and Average	Test Voltage:	12Vdc

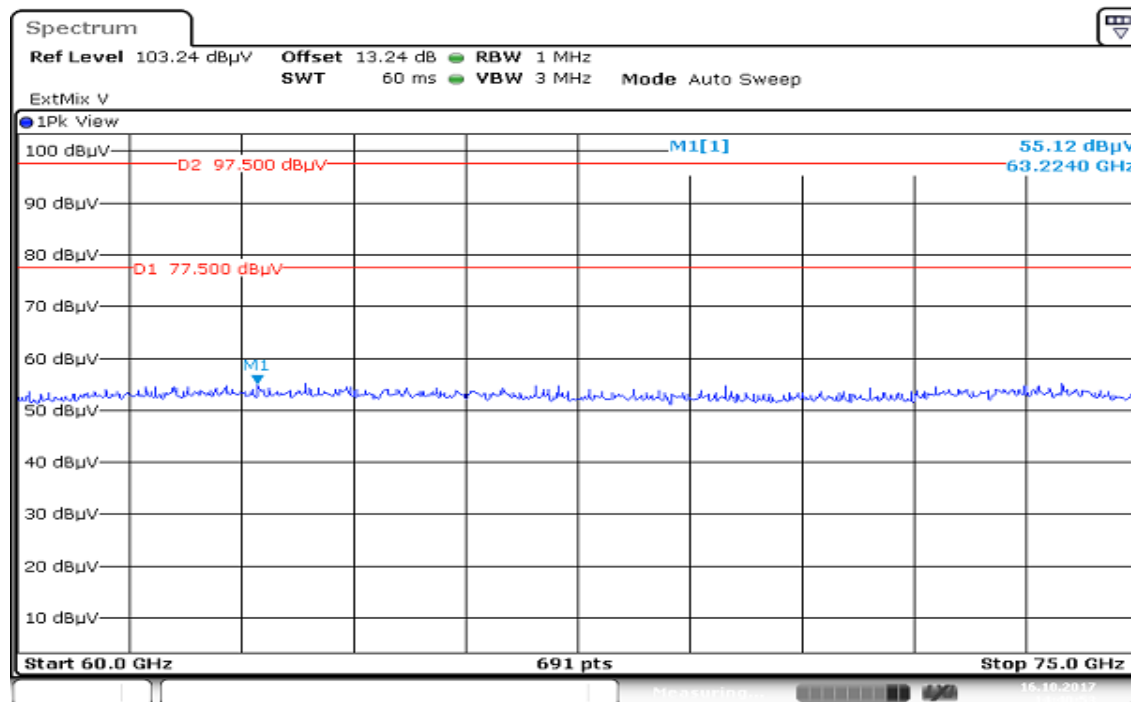

Date: 16.OCT.2017 14:40:53

**Remark:**

1. Measuring frequencies from 1 GHz to the 10th harmonic of highest fundamental frequency.
2. For above 1GHz, the EUT peak value was under average limit, therefore the Average value compliance with the average limit

Test Mode:	TX-24GHz	Temp/Hum	24(°C)/ 33%RH
Test Item	75GHz-110GHz	Test Date	October 16, 2017
Polarize	Vertical/Horizontal	Test Engineer	Kevin Kuo
Detector	Peak and Average	Test Voltage:	12Vdc

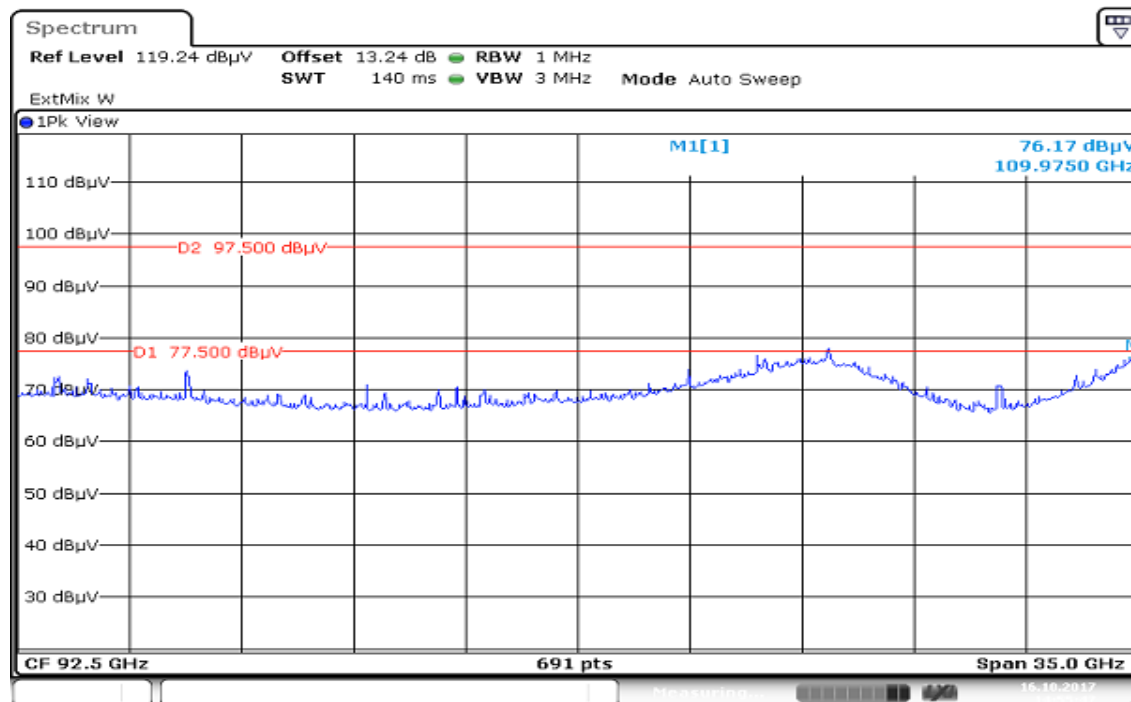

**Remark:**

1. Measuring frequencies from 1 GHz to the 10th harmonic of highest fundamental frequency.
2. For above 1GHz, the EUT peak value was under average limit, therefore the Average value compliance with the average limit

Test Mode:	TX-24GHz	Temp/Hum	24(°C)/ 33%RH
Test Item	110GHz-170GHz	Test Date	October 16, 2017
Polarize	Vertical/Horizontal	Test Engineer	Kevin Kuo
Detector	Peak and Average	Test Voltage:	12Vdc

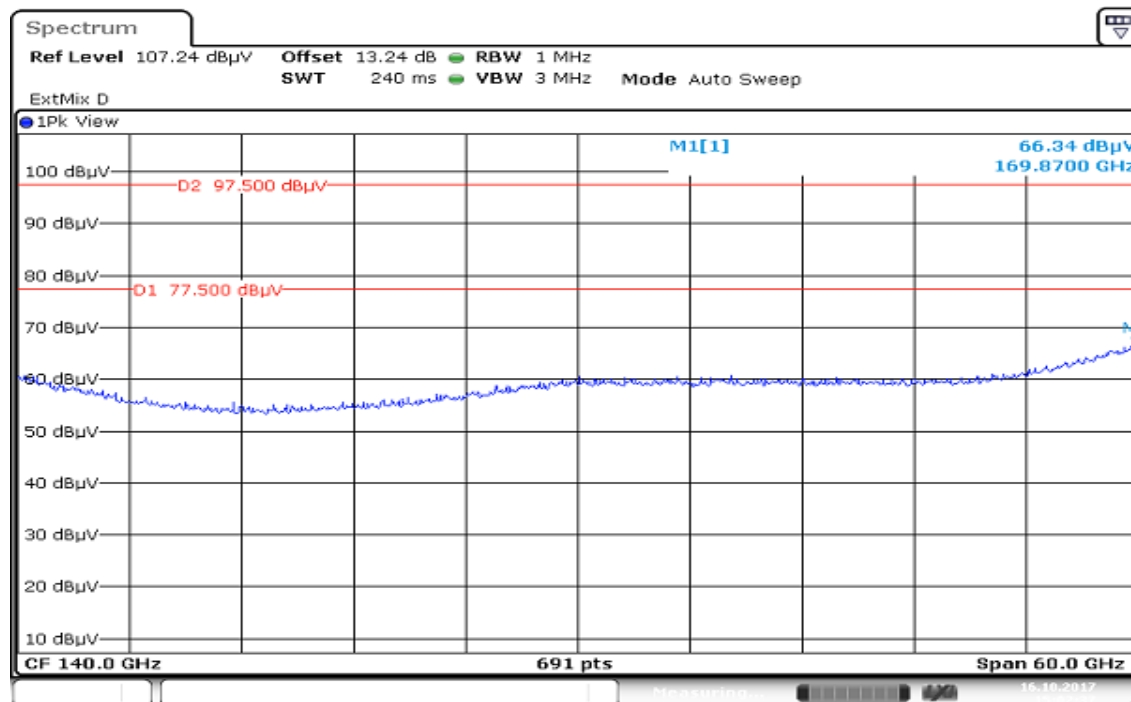

**Remark:**

1. Measuring frequencies from 1 GHz to the 10th harmonic of highest fundamental frequency.
2. For above 1GHz, the EUT peak value was under average limit, therefore the Average value compliance with the average limit

Test Mode:	TX-24GHz	Temp/Hum	24(°C)/ 33%RH
Test Item	170GHz-220GHz	Test Date	October 16, 2017
Polarize	Vertical/Horizontal	Test Engineer	Kevin Kuo
Detector	Peak and Average	Test Voltage:	12Vdc

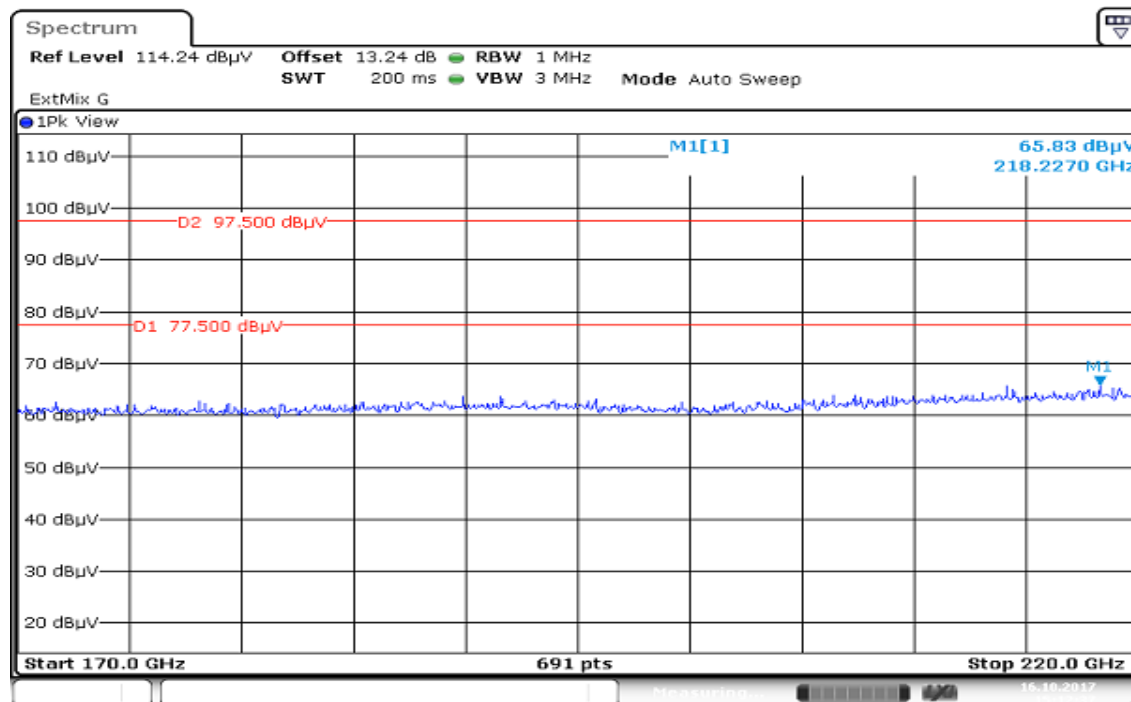

**Remark:**

1. Measuring frequencies from 1 GHz to the 10th harmonic of highest fundamental frequency.
2. For above 1GHz, the EUT peak value was under average limit, therefore the Average value compliance with the average limit

Test Mode:	TX-24GHz	Temp/Hum	24(°C)/ 33%RH
Test Item	220GHz-250GHz	Test Date	October 16, 2017
Polarize	Vertical/Horizontal	Test Engineer	Kevin Kuo
Detector	Peak and Average	Test Voltage:	12Vdc

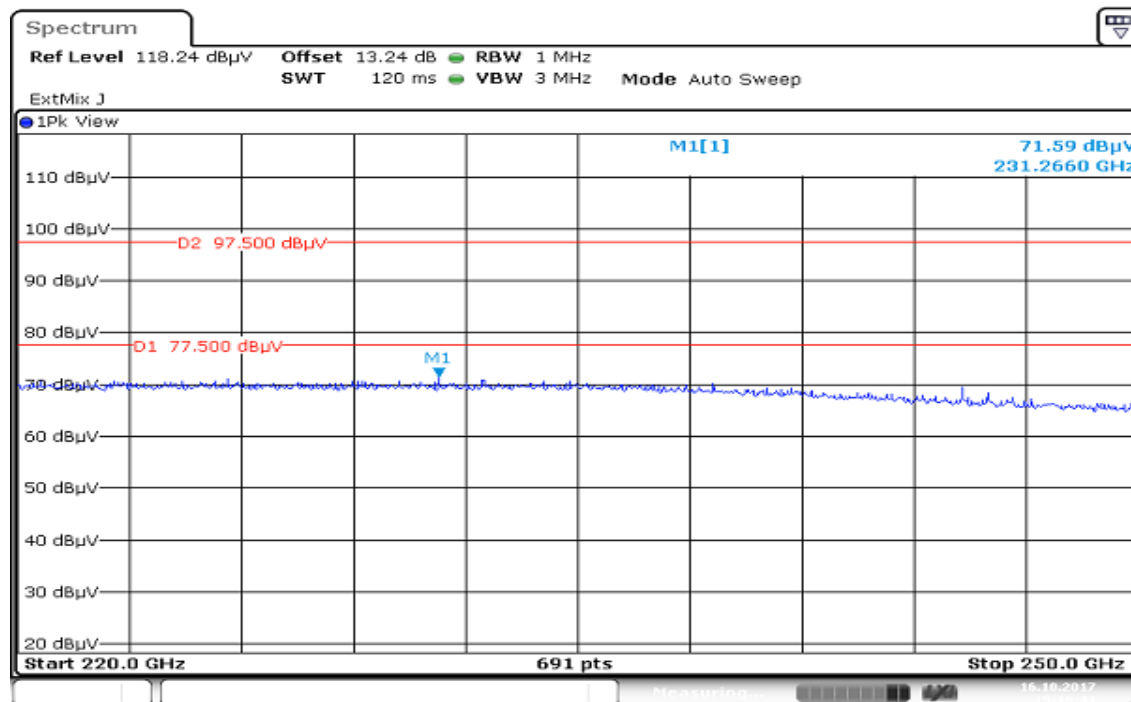

**Remark:**

1. Measuring frequencies from 1 GHz to the 10th harmonic of highest fundamental frequency.
2. For above 1GHz, the EUT peak value was under average limit, therefore the Average value compliance with the average limit
3. Above 220G, noise floor is higher than EUT signal..

**APPENDIX-1 Test Photo  
Radiation (Below 1GHz)**



**Radiation (Above 1GHz)  
1-18GHz**

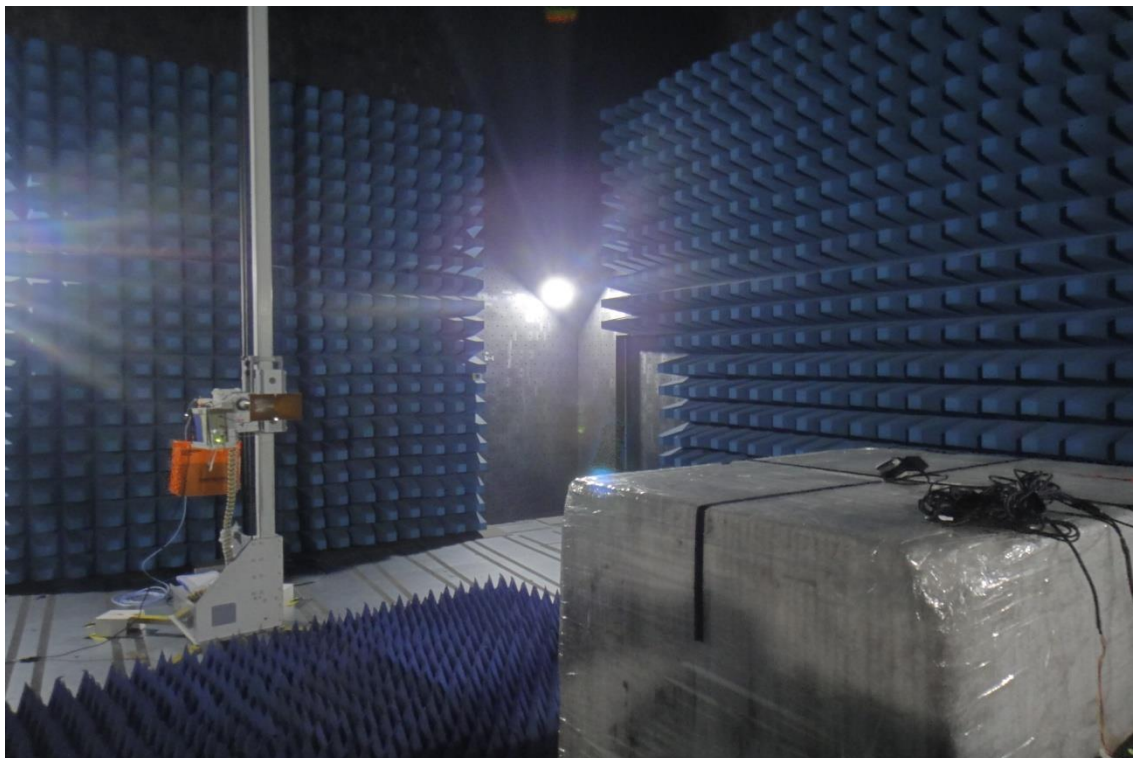

## Radiation (Above 18GHz)

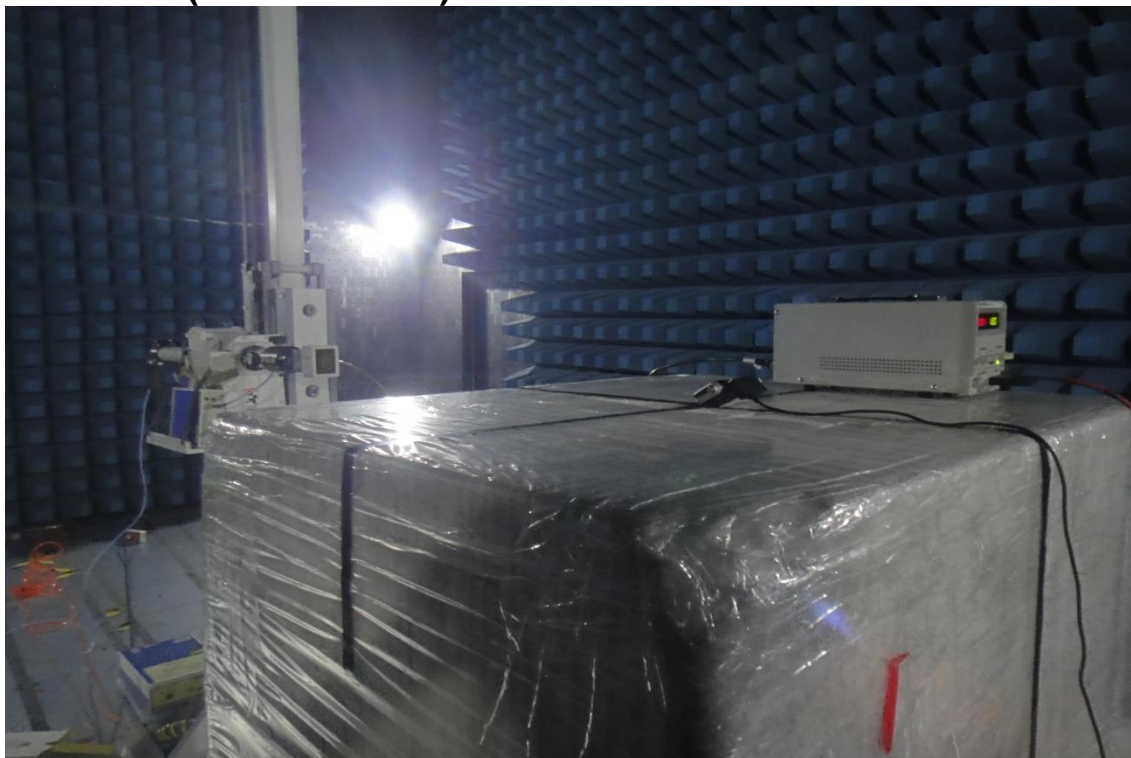

## CONDUCTED EMISSIONS SETUP PHOTOS

