

TEST REPORT

Report No: KST-FCR-090016

Applicant	Name	Dasan Electron Co.,Ltd.
	Address	# 606, Godowhadong, Gyunggi Techno Park, 1271-11, Sa-dong, Ansan-Si, Gyeonggi-do, Korea
Manufacturer	Name	Dasan Electron Co.,Ltd.
	Address	# 606, Godowhadong, Gyunggi Techno Park, 1271-11, Sa-dong, Ansan-Si, Gyeonggi-do, Korea
Equipment	Name	Wireless Headset Base
	Model No	DW-773B
	Brand Name	None
	FCC ID	WF2DW-773B
Test Standard	FCC CFR 47, Part 15. Subpart C-15.247	
Test Date(s)	2009. 12. 11 ~ 2009. 12. 15	
Issue Date	2008. 12. 16	
Test Result	Compliance	

Supplementary Information

The device bearing the brand name and FCC ID specified above has been shown to comply with the applicable technical standards as indicated in the measurement report and was tested in accordance with measurement procedures specified in [ANSI C 63.4-2003](#).

We attest to the accuracy of data and all measurements reported herein were performed by KOSTEC Co., Ltd. and were made under Chief Engineer's supervision. We assume full responsibility for the completeness of these measurements and vouch for the qualifications of all persons taking them.

Tested by Mi Young, Lee

Approved by Gyeong Hyeon, Park

Signature



Signature



Table of Contents

1. GENERAL INFORMATION	3
1.1 Test Facility	3
1.2 Location	3
2. EQUIPMENT DESCRIPTION	4
3. SYSTEM CONFIGURATION FOR TEST	5
3.1 Characteristics of equipment.....	5
3.2 Configuration of EUT	5
3.3 Product Modification.....	5
3.4 Operating Mode.....	5
3.5 Test Configuration.....	5
3.6 Test Jig	6
3.7 Used Test Equipment List.....	7
4. SUMMARY TEST RESULTS	8
5. MEASUREMENT RESULTS	9
5.1 6 dB Bandwidth	9
5.2 Max. Conducted peak output power	11
5.3 Conducted peak power spectral density	14
5.4 Band-edge Compliance	17
5.5 Spurious RF conducted emissions	20
5.6 Spurious RF Radiated emissions	24
5.7 Antenna requirement	29
5.8 AC Power Conducted emissions	30

1. GENERAL INFORMATION

1.1 Test Facility

Test laboratory and address

KOSTEC Co., Ltd.

180-254, Annyeong-dong, Hwaseong-si, Gyeonggi-do, South Korea

The open area field test site and conducted measurement facility are used for these testing. This site at was fully described in a reports submitted to the Federal Communications Commission (FCC).

The details of these reports have been found to be in complies with the requirements of Section 2.948 of the FCC Rules on November 14, 2002. The facility also complies with the radiated and conducted test site criteria set forth in ANSI C63.4-2003.

The Federal Communications Commission (FCC) has the reports on file and KOSTEC Co., Ltd. is listed under FCC Registration No.525762. The test site has been approved by the FCC for public use and is list in the FCC Public Access Link CORES (Commission Registration System) and Industry Canada office (Industry Canada Site No.: 8305A)

Registration information

KCC (Korea Communications Commission) Number : KR0041

KOLAS(Korea Laboratory Accreditation Scheme) Number : 232

FCC Registration Number(FRN) : 525762

IC Company Number(C,N) : 8305A

VCCI Registration Number : R-1657 / C -1763

1.2 Location



2. EQUIPMENT DESCRIPTION

The product operation described herein was declared by manufacturer. and refer to user's manual for the details.

1) Equipment Name	Wireless Headset Base
2) Model No	DW-773B
3) Brand Name	None
4) Serial Number	Prototype
5) Emission Type	F1D
6) Oscillation Type	PLL (Phase Local Loop)
7) Modulation Type	Digital Modulation (GFSK)
8) Operated Frequency	TX/RX : 2 402 MHz ~ 2 478 MHz
9) Power	Max. 2.50 mW (Conducted power declared by applicant)
9) Channel spacing	77 Ch
10) Communication Type	Half duplex
11) Communication access Method	CSMA-CA(Channel selection Multiple Access Collision Avoid)
12) Micro Processor	U3(ATMEGA88V/MLF)
13) Weight / Dimension	232g / 15(L) cm x 12(W) cm x 140(D) cm
14) Operation temperature	- 40 °C ~ + 70 °C
15) Power Source	Voltage: 9.0 V _{DC} (External Adaptor output)
	Current: 500 mA (TX Operation mode)
16) Antenna Description	Class: Chip ANT, Connect type: Internal, Gain: 0.58 dBi (in-band)
17) FCC ID	WF2DW-773B

3. SYSTEM CONFIGURATION FOR TEST

3.1 Characteristics of equipment

This equipment is named Wireless Headset Base and it has been developed using the latest wireless technology. with a comfort and freedom compared to using a standard telephone for making and receiving call For more operation and specification is refer to user manual

RF part of this product is consist of one chip type and used frequency band is 2 402 MHz ~ 2 478 MHz, Maximum conduction power is 2.5 mW and also when during communication, if the same the other interference signal is detected it is designed to avoid the other channel

Power source is supplied 9.0 V_{DC} from external adaptor

3.2 Configuration of EUT

Description	Model No.	Serial No.	Manufacture	Remark
Wireless Headset Base	DW-773B	None	Dasan Electron Co.,Ltd.	EUT
Adaptor	YHD0900500U-33	None	SHENZHEN YONGHAO TECHNOLOGY CO.,LTD.	9 V _{DC} , 500mA

3.3 Product Modification

N/A

3.4 Operating Mode

The transmitter was operated in a continuous modulation transmit mode and all measurements were intended to emit maximum RF signal

3.5 Test Configuration

Test Layout is difference according to test items at the clause 5.1 to 5.8
Below test setup is only configured peripheral device of EUT

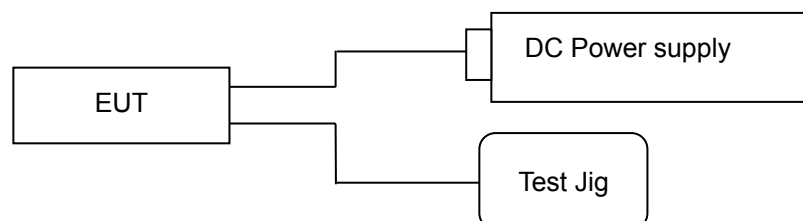

3.6 Test Jig

During test , the below “test Jig with button” provided by the supplier was used to the control the channel select & modulated signal and carrier controlling software program.

Output power expected by the customer and is going to be fixed on the firmware of the final end product.

■ Test Jig with RF Radio equipment

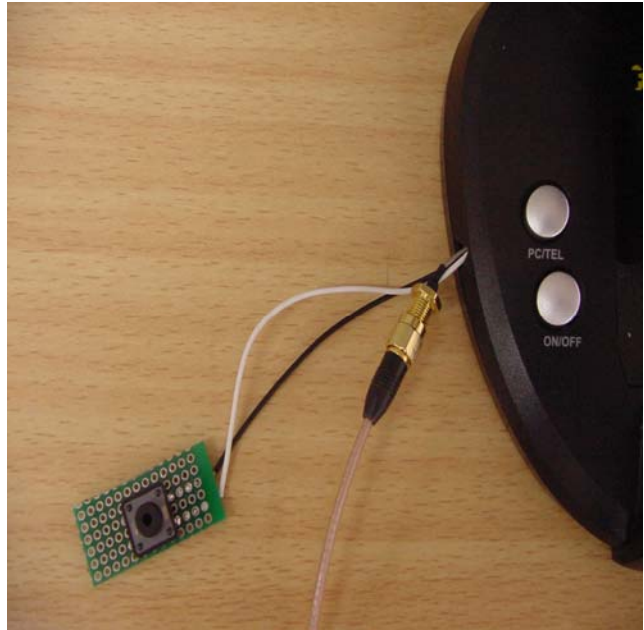

■ Table for Channel setting number

Frequency (MHz)	2 402	2 439	2 478
Channel Number	Ch 1	Ch 38	Ch 77
	Lowest channel	Middle channel	Highest channel

3.7 Used Test Equipment List

No.	Instrument	Model	Serial No.	Manufacturer	Due to Cal. Date	Used
1	Spectrum Analyzer	8563E	3846A10662	Agilent Technology	2010.05.20	<input checked="" type="checkbox"/>
2	Test Receiver	ESCS30	100111	Rohde & Schwarz	2010.03.07	<input checked="" type="checkbox"/>
3	Test Receiver	ESPI3	100109	Rohde & Schwarz	2010.03.03	<input type="checkbox"/>
4	LISN	ESH2-Z5	100044	Rohde & Schwarz	2010.03.16	<input checked="" type="checkbox"/>
5	LISN	ESH3-Z5	100147	Rohde & Schwarz	2010.06.25	<input checked="" type="checkbox"/>
6	Ultra broadband Antenna	HL562	100075	Rohde & Schwarz	2010.03.20	<input checked="" type="checkbox"/>
7	Ultra broadband Antenna	HL562	100076	Rohde & Schwarz	2010.04.14	<input type="checkbox"/>
8	Dipole Antenna	HZ-12	100005	Rohde & Schwarz	2010.04.03	<input type="checkbox"/>
9	Dipole Antenna	HZ-13	100007	Rohde & Schwarz	2010.04.03	<input type="checkbox"/>
10	Horn Antenna	3115	2996	EMCO	2010.06.13	<input checked="" type="checkbox"/>
11	Loop Antenna	6502	9203-0493	EMCO	2011.06.11	<input type="checkbox"/>
12	Digital Signal Generator	E4436B	US39260458	HP	2010.05.20	<input checked="" type="checkbox"/>
13	Tracking CW Signal Source	85645A	070521-A1	HP	2010.05.20	<input type="checkbox"/>
14	RF Power Amplifier	8347A	3307A01571	HP	2010.05.20	<input checked="" type="checkbox"/>
15	Microwave Amplifier	8349B	2627A01037	HP	2010.05.20	<input checked="" type="checkbox"/>
16	Attenuator	8498A	3318A09485	HP	2010.05.20	<input checked="" type="checkbox"/>
17	Temperature & Humidity Chamber	EY-101	90E14260	TABAI ESPEC	2010.03.16	<input type="checkbox"/>
18	EPM Series Power meter	E4418B	GB39512547	Agilent Technology	2010.05.20	<input type="checkbox"/>
19	RF Power Sensor	ECP-E18A	US37181768	Agilent Technology	2010.05.20	<input type="checkbox"/>
20	Microwave Frequency Counter	5352B	2908A00480	Agilent Technology	2010.05.20	<input type="checkbox"/>
20	Band rejection filter	WTR-BRF2442-84NM	09020001	WAVE TECH Co.,Ltd.	2010.03.03	<input checked="" type="checkbox"/>
21	SLIDAC	None	0207-4	Myoung-Sung Electronic Co., Ltd.	2010.05.20	<input type="checkbox"/>
22	DC Power supply	DRP-5030	9028029	Digital Electronic Co.,Ltd	2010.06.04	<input type="checkbox"/>
23	DC Power supply	UP-3005T	68	Unicon Co.,Ltd	2010.05.20	<input type="checkbox"/>
24	DC Power supply	E3610A	KR24104505	Agilent Technology	2010.05.20	<input type="checkbox"/>
25	Antenna Master	-	-	Daeil EMC	-	<input checked="" type="checkbox"/>
26	Turn Table	-	-	Daeil EMC	-	<input checked="" type="checkbox"/>

4. SUMMARY TEST RESULTS

Description of Test	Standard Section	Reference Section	Test Result	Remark
6 dB Bandwidth	15.247(a)(2)	Clause 5.1	Compliance	
Max. Conducted peak output power	15.247(b)(3)	Clause 5.2	Compliance	
Conducted peak output power spectrum density	15.247(e)	Clause 5.3	Compliance	
Band edge compliance	15.247(d)	Clause 5.4	Compliance	
Spurious RF conducted emissions	15.247(d)	Clause 5.5	Compliance	
Spurious RF radiated emissions	15.247(d), 15.209	Clause 5.6	Compliance	
Antenna requirement	15.203, 15.247	Clause 5.7	Compliance	
AC Power line Conducted emission	15.207	Clause 5.8	Compliance	
<p>Compliance : The EUT complies with the essential requirements in the standard. Not Compliance : The EUT does not comply with the essential requirements in the standard. N/A : The test was not applicable in the standard.</p>				

5. MEASUREMENT RESULTS

5.1 6 dB Bandwidth

5.1.1 Standard Applicable [FCC §15.247(a),(2)]

System using digital modulation techniques may operate in the 2 400 ~ 2 483.5 MHz band

The minimum 6 dB bandwidth shall be at least 500 KHz

5.1.2 Test Environment conditions

- Ambient temperature : 22 °C,
- Relative Humidity : (47 ~ 49) % R.H.

5.1.3 Measurement Procedure

The 6 dB occupied bandwidth was measured with a spectrum analyzer connected to the antenna terminal while EUT had its digitally modulated function enabled.

For more detailed test procedure and measurement method FCC Public Notice(DA 00-705) setting method on spectrum analyzer is as follows ;

- Span : approximately 2 to 3 times the 20 dB bandwidth
- RBW : $\geq 1\%$ of the 20 dB bandwidth
- VBW : \geq RBW
- Sweep : auto
- Detector function : peak
- Trace : max hold

5.1.4 Measurement Result

Channel No.	Frequency [MHz]	Test Results		
		Measured Bandwidth [KHz]	Limit	Result
1	2 402 MHz	280	at least 500 kHz	Pass
38	2 439 MHz	282		Pass
77	2 478 MHz	256		Pass

5.1.5 Test Plot

Channel 1 (2 402 MHz)

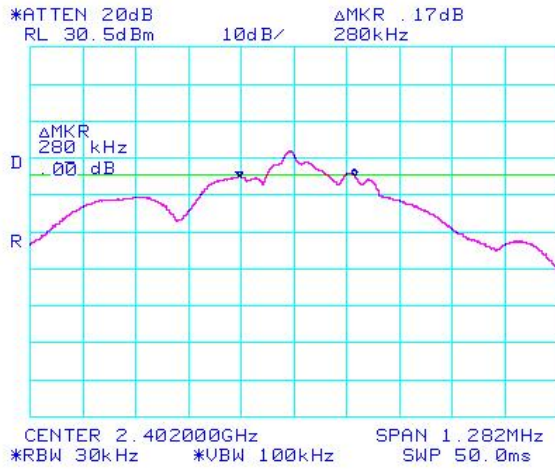

Channel 38 (2 439 MHz)

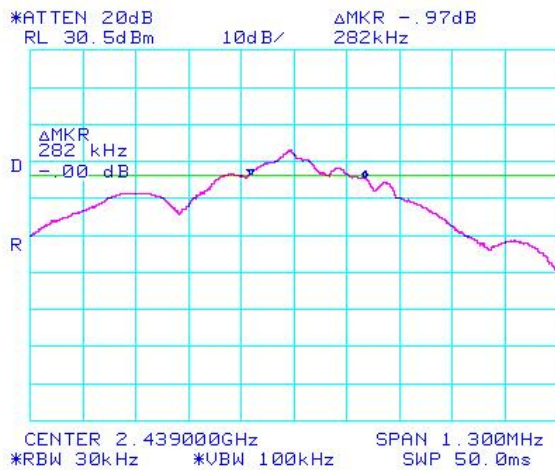

Channel 77 (2 478 MHz)

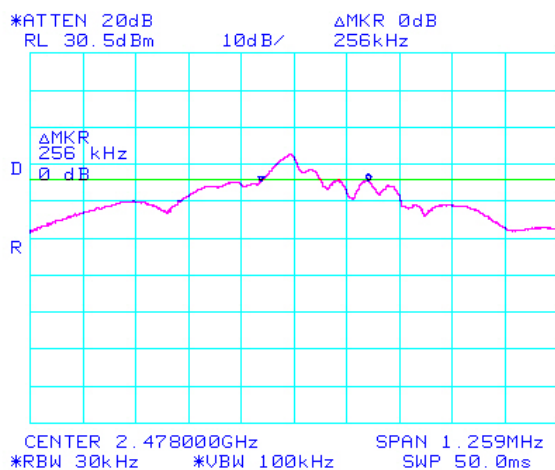

5.2 Max. Conducted peak output power

5.2.1 Standard Applicable [FCC §15.247(b)(3)]

For systems using digital modulation in the 2 400 MHz ~ 2 483.5 MHz bands : 1 Watt.

As an alternative to a peak power measurement, compliance with the one Watt limit can be based on a measurement of the maximum conducted output power.

5.2.2 Test Environment conditions

- Ambient temperature : 22 °C,
- Relative Humidity : (47 ~ 49) % R.H.

5.2.3 Measurement Procedure

- ① Pre-calibration for the spectrum analyzer has to be done first through a reference CW signal from CAL OUT(-10 dBm)
- ② Reference frequency signal generated from the signal generator is supply to RF input port in spectrum Analyzer via dc Block, RF cable and attenuator. and then, it's apply to offset value in spectrum analyzer as follows :
on Spectrum analyzer [Amplitude→1 More of 3→REF LVL OFFSET (31.5 dB)]
 - dc Block(1.0 dB)+Cable loss(0.5 dB)+Attenuator (30 dB)
- ③ Remove the antenna from the EUT and then, connected to spectrum analyzer via a dc Block, suitable low loss RF cable and attenuator.
- ④ Place the EUT on the table and set it hopping function disable at the highest, middle and the lowest available channels.
- ⑤ After the trace being stable, Use the marker-to-peak function to set the marker to the peak of the emission
- ⑥ The indicated level is the peak output power.
- ⑦ please refer to the detailed procedure method FCC Public Notice(DA 00-705)

*The spectrum analyzer is set to the as follows ;

- Span : approximately 5 times the 20 dB bandwidth
- RBW : > 20 dB bandwidth of the emission being measured
- VBW : ≥ RBW
- Sweep : auto
- Detector function : peak
- Trace : max hold

* above measurement frequency is selected to the lowest, Middle and Highest channel

5.2.4 Test Setup Configuration

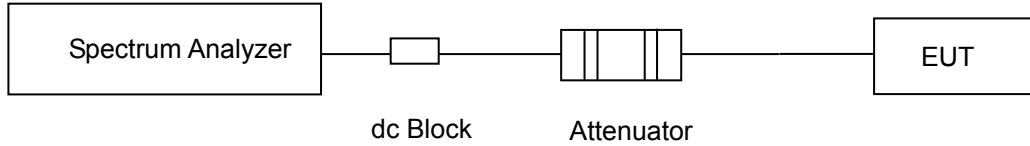

5.2.5 Measurement Result

Channel No.	Frequency [MHz]	Test Results		
		Measured power [dBm]	Limit [dBm]	Result
1	2 402	2.33	≤ 30	Pass
38	2 439	3.33		Pass
77	2 478	3.28		Pass

5.3 Conducted peak power spectral density

5.3.1 Standard Applicable [FCC §15.247(e)]

For digitally modulated systems, the power spectral density conducted from the intentional radiator to the antenna shall not be greater than 8 dBm in any 3 kHz band during any time interval of continuous transmit

5.3.2 Test Environment conditions

- Ambient temperature : 22 °C,
- Relative Humidity : (47 ~ 49) % R.H.

5.3.3 Measurement Procedure

- ① Pre-calibration for the spectrum analyzer has to be done first through a reference CW signal from CAL OUT(-10 dBm)
- ② Reference frequency signal generated from the signal generator is supply to RF input port in spectrum Analyzer via dc Block, RF cable and attenuator. and then, it's apply to offset value in spectrum analyzer as follows :
on Spectrum analyzer [Amplitude→1 More of 3→REF LVL OFFSET (31.5 dB)]
 - dc Block(1.0 dB)+Cable loss(0.5 dB)+Attenuator (30 dB)
- ③ Remove the antenna from the EUT and then, connected to spectrum analyzer via a dc Block, suitable low loss RF cable and attenuator.
- ④ Place the EUT on the table and set it hopping function disable at the highest, middle and the lowest available channels.
- ⑤ After the trace being stable, Use the marker-to-peak function to set the marker to the peak of the emission
- ⑥ The indicated level is the peak output power.
- ⑦ please refer to the detailed procedure method FCC Public Notice(DA 00-705)

The spectrum analyzer is set to the as follows :

- Span : 563.8 kHz
- RBW : 3 kHz
- VBW : 3 kHz (≥ RBW)
- Sweep : auto
- Detector function : peak
- Trace : max hold

5.3.4 Test Setup Configuration

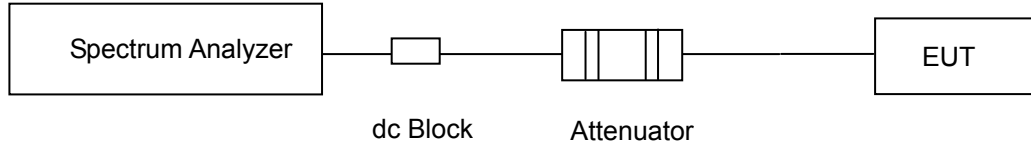

5.3.5 Measurement Result

Channel No.	Frequency [MHz]	Test Results		
		Measured PSD [dBm]	Limit	Result
1	2 402	- 1.03	≤ 8 dBm	Complies
38	2 439	- 1.70		Complies
77	2 478	- 0.03		Complies

5.4 Band-edge Compliance

5.4.1 Standard Applicable [FCC §15.247(d)]

In any 100 kHz bandwidth outside the frequency band in which the digitally modulated intentional radiator is operating, the radio frequency power that is produced by the intentional radiator shall be at least 20 dB below that in the 100 kHz bandwidth within the band that contains the highest level of the desired power.

5.4.2 Test Environment conditions

- Ambient temperature : 22 °C,
- Relative Humidity : (47 ~ 49) % R.H.

5.4.3 Measurement Procedure

- ① Pre-calibration for the spectrum analyzer has to be done first through a reference CW signal from CAL OUT(-10 dBm)
- ② Reference frequency signal generated from the signal generator is supply to RF input port in spectrum Analyzer via dc Block, RF cable and attenuator. and then, it's apply to offset value in spectrum analyzer as follows :
on Spectrum analyzer [Amplitude→1 More of 3→REF LVL OFFSET (31.5 dB)]
 - dc Block(1.0 dB)+Cable loss(0.5 dB)+Attenuator (30 dB)
- ③ Remove the antenna from the EUT and then, connected to spectrum analyzer via a dc Block, suitable low loss RF cable and attenuator.
- ④ Place the EUT on the table and set on the emission at the band-edge,
- ⑤ After the trace being stable, Use the marker-to-peak function to move the marker to the peak of the in-band emission.
- ⑥ The marker-delta value now displayed must comply with the limit specified in above standard.
- ⑦ please refer to the detailed procedure method FCC Public Notice(DA 00-705)

The spectrum analyzer is set to the as follows :

- Span : Wide enough to capture the peak level of the emission operating on the channel closet to the Band-edge, as well as any modulation products which fall outside of the authorized band of operation
- RBW : ≥ 1 % of the span
- VBW : \geq RBW
- Sweep : auto
- Detector function : peak
- Trace : Max hold

5.4.4 Test Setup Configuration

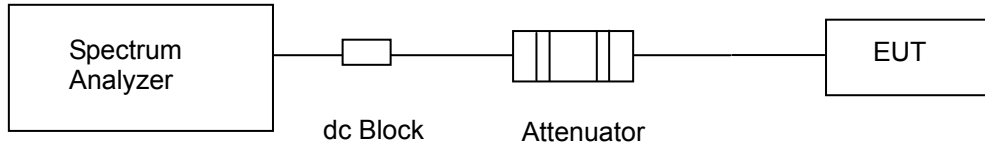

5.4.5 Measurement Result

Setting Channel	Frequency Range [MHz]	Test Results		
		Measured value [dBc]	Limit [dBc]	Result
Lowest channel_1 (2 402 MHz)	2,400 000 MHz ~ 2,402 282 MHz	- 41.00	≤ - 20	Pass
Highest channel_77 (2 478 MHz)	2.476 859 MHz ~ 2.483 500 MHz	- 43.50		Pass

5.4.6 Test Plot

Lowest Channel_01 (2 402 MHz)

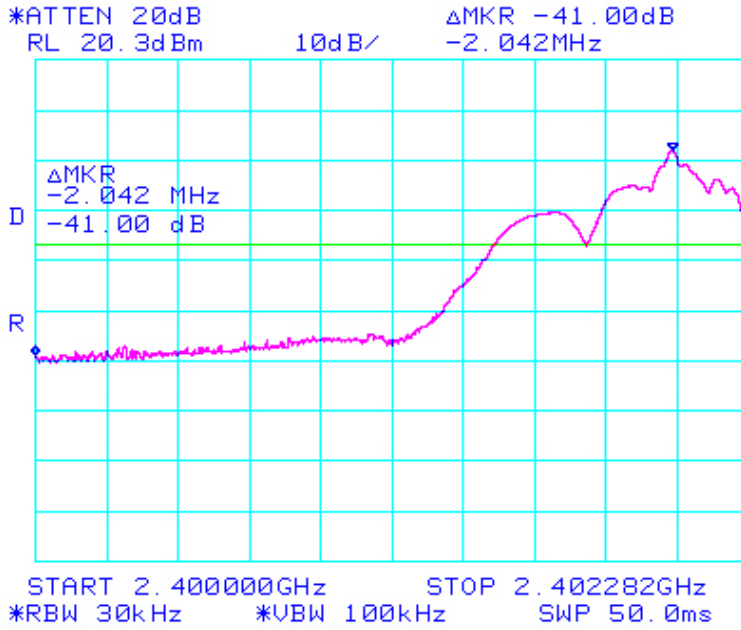

Highest Channel_77 (2 478 MHz)

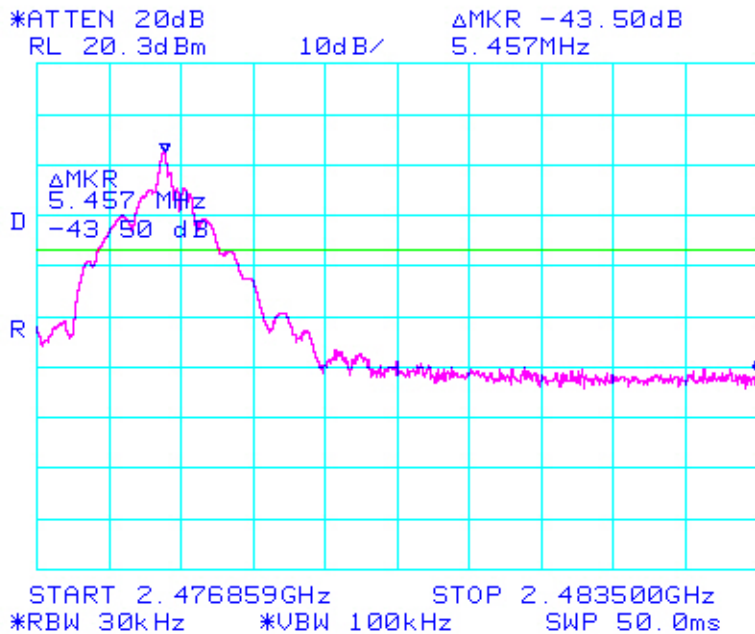

※ Above measured delta value is displayed at band edge point from lowest and highest frequency

5.5 Spurious RF conducted emissions

5.5.1 Standard Applicable [FCC §15.247(d)]

In addition in this clause 5.4.1 In any 100 kHz bandwidth outside the frequency band in which the digitally modulated intentional radiator is operating, the radio frequency power that is produced by the intentional radiator shall be at least 20 dB below that in the 100 kHz bandwidth within the band that contains the highest level of the desired power.

5.5.2 Test Environment conditions

- Ambient temperature : 22 °C,
- Relative Humidity : (47 ~ 49) % R.H.

5.5.3 Measurement Procedure

- ① Pre-calibration for the spectrum analyzer has to be done first through a reference CW signal from CAL OUT(-10 dBm)
- ② Reference frequency signal generated from the signal generator is supply to RF input port in spectrum Analyzer via dc Block, RF cable and attenuator. and then, it's apply to offset value in spectrum analyzer as follows :
on Spectrum analyzer [Amplitude→1 More of 3→REF LVL OFFSET (31.5 dB)]
 - dc Block(1.0 dB)+Cable loss(0.5 dB)+Attenuator (30 dB)
- ③ Remove the antenna from the EUT and then, connected to spectrum analyzer via a dc Block, suitable low loss RF cable and attenuator.
- ④ Place the EUT on the table and set on the emission at the out band
- ⑤ After the trace being stable, Use the marker-to-peak function to move the marker to the peak of the in-band emission.
- ⑥ The marker-delta value now displayed spurious emission must comply with the limit specified in above standard.
- ⑦ please refer to the detailed procedure method FCC Public Notice(DA 00-705)

The spectrum analyzer is set to the as follows :

- Span : wide enough to capture the peak level of the in-band emission and all spurious emissions from the Lowest frequency generated in the EUT up through the 10th harmonic. Typically, several plots are required to cover this entire span.
 - RBW : 100 kHz
 - VBW : ≥ RBW
 - Sweep : Auto
 - Detector function : Peak
 - Trace : Max hold

* Test setup of configuration is same as in this clause 5.4.4

5.5.4 Measurement Result

Setting channel and frequency		Frequency Range [MHz]	Test Results	
Channel No.	Frequency [MHz]		Limit [dBc]	Result
1	Lowest channel (2 402 MHz)	30 MHz ~ 3.0 GHz	≤ - 20	Pass
		1 GHz ~ 26.5 GHz		Pass
38	Middle channel (2 439 MHz)	30 MHz ~ 3.0 GHz		Pass
		1 GHz ~ 26.5 GHz		Pass
77	Highest channel (2 478 MHz)	30 MHz ~ 3.0 GHz		Pass
		1 GHz ~ 26.5 GHz		Pass

*Note: Spurious level at digitally modulation mode is 20dB below within the band that contains the highest level of the desired power. see to as below Test Plot of 5.5.5

5.5.5 Test Plot

Lowest Channel 30 MHz ~ 3.0 GHz

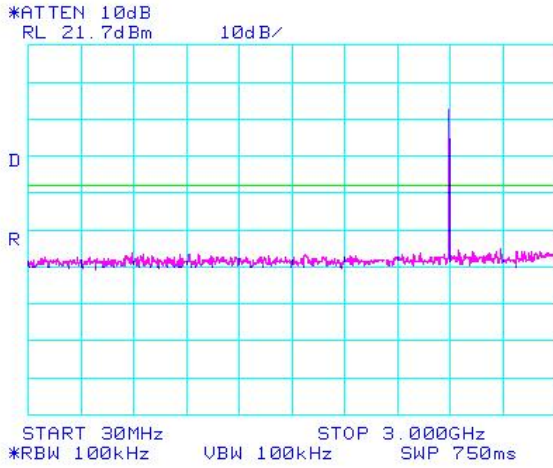

Lowest Channel 1 GHz ~ 26.5 GHz

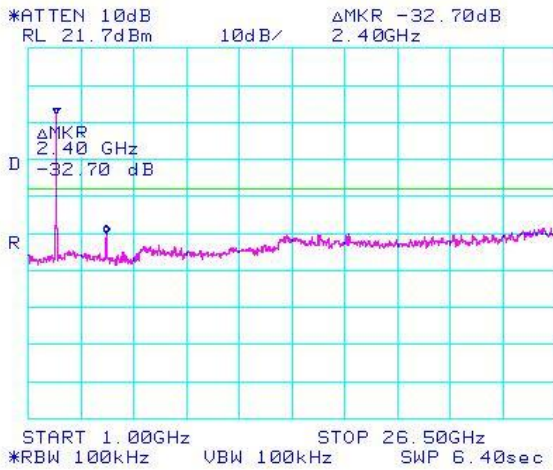

Middle Channel 30 MHz ~ 3.0 GHz

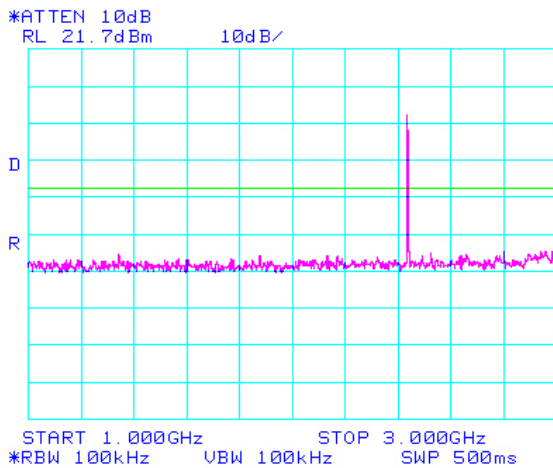

⇒Continuous

Middle Channel 1 GHz ~ 26.5 GHz

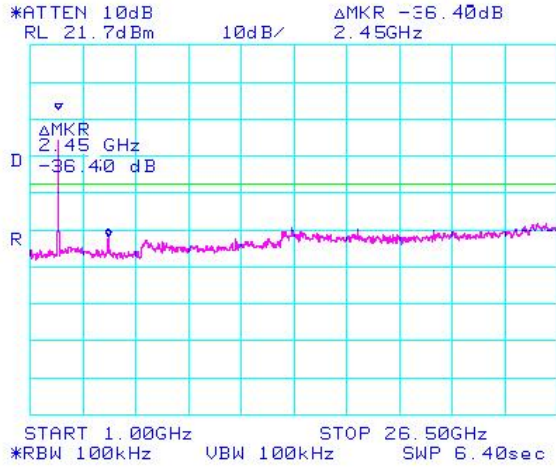

Highest Channel 30 MHz ~ 3.0 GHz

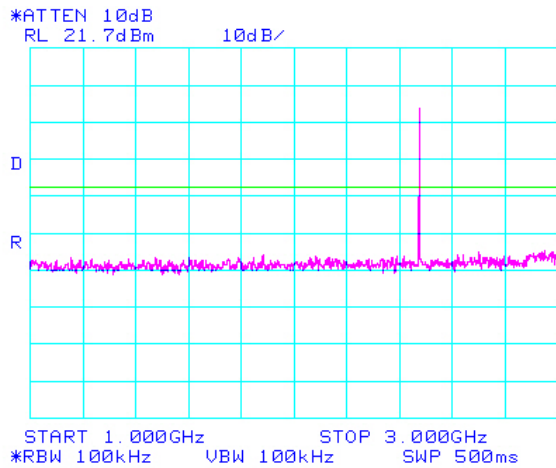

Highest Channel 1 GHz ~ 26.5 GHz

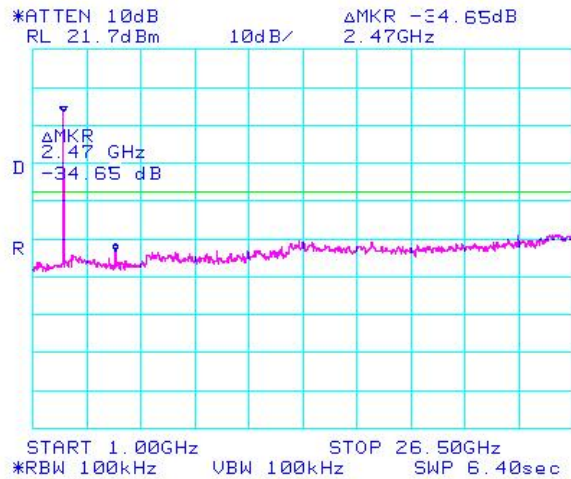

5.6 Spurious RF Radiated emissions

5.6.1 Standard Applicable [FCC §15.247(d)]

All other emissions outside these bands shall not exceed the general radiated emission limits specified in §15.209(a). And according to §15.33(a)(1), for an intentional radiator operates below 10 GHz, the frequency Range of measurements : to the tenth harmonic of the highest fundamental frequency or to 40 GHz, Whichever is lower. In addition, radiated emissions which fall in the restricted bands, as defined in Sec.15.205(a), must also comply with the radiated emission limits specified in Sec. 15.209(a)

§15.209. limits for radiated emissions measurements (distance at 3m)

Frequency Band [MHz]	Limit [$\mu\text{V}/\text{m}$]	Limit [$\text{dB}\mu\text{V}/\text{m}$]	Detector
30 - 88	100 **	40.00	Quasi peak
88 - 216	150 **	43.52	Quasi peak
216 - 960	200 **	46.02	Quasi peak
Above 960	500	54.00	Average

** fundamental emissions from intentional radiators operation under this Section shall not be located in the frequency bands 54-72 MHz, 76-88 MHz, 174-216 MHz, or 470-806 MHz. However, operation within these Frequency bands is permitted under other sections of this Part Section 15.231 and 15.241

§15.205. [Table 1] : Restrict Band of Operation

Only spurious emissions are permitted in any of the frequency bands listed below ;			
[MHz]	[MHz]	[MHz]	[GHz]
0.090 - 0.110	16.42 - 16.423	399.9 - 410	4.5 - 5.15
0.495 - 0.505**	16.694 75 - 16.695 25	608 - 614	5.35 - 5.46
2.173 5 - 2.190 5	16.804 25 - 16.804 75	960 - 1 240	7.25 - 7.75
4.125 - 4.128	25.5 - 25.67	1 300 - 1 427	8.025 - 8.
4.177 25 - 4.177 75	37.5 -38.25	1 435 - 1 626.5	9.0 - 9.2
4.207 25 - 4.207 75	73 - 74.6	1 645.5 - 1 646.5	9.3 - 9.5
6.215 - 6.218	74.8 - 75.2	1 660 - 1 710	10.6 - 12.7
6.267 75 - 6.268 25	108 - 121.94	1 718.8 - 1 722.2	13.25 - 13.
6.311 75 - 6.312 25	123 - 138	2 200 - 2 300	14.47 - 14.5
8.291 - 8.294	149.9 - 150.05	2 310 - 2 390	15.35 - 16.2
8.362 - 8.366	156.524 75 - 156.525 25	2 483.5 - 2 500	17.7 - 21.4
8.376 25 - 8.38 6 75	156.7 - 156.9	2 690 - 2 900	22.01 - 23.12
8.414 25 - 8.414 75	162.012 5 - 167.17	3 260 - 3 267	23.6 - 24.0
12.29 - 12.293	167.72 - 173.2	3 332 - 3 339	31.2 - 31.8
12.519 75 - 12.520 25	240 - 285	3 345.8 - 3 358	36.43 - 36.5
12.576 75 - 12.577 25	322 - 335.4	3 600 - 4 400	Above 38.6

** Until February 1, 1999, this restricted band shall be 0.490-0.510

5.6.2 Test Environment conditions

- Ambient temperature : 20 °C,
- Relative Humidity : (48 ~ 50) % R.H.
- Pressure : 100.5 kPa

5.6.3 Measurement Procedure

- ① As below test setup figure, for frequencies measured below and above 1 GHz respectively. Turn on EUT and make sure that it is test mode function. Also was placed on a non-metallic table height of 0.8 m above the reference ground plane. If EUT is connected to cables, that were fixed to cause maximum emission. Horn antenna was used to for above 1 GHz and Broadband antenna below 1 GHz. it made with the antenna positioned in both the horizontal and vertical planes of polarization.
- ② For emission frequencies measured each below and above 1 GHz, a pre-scan is performed in a Shield chamber to determine the accurate frequencies before final test, after maximum emissions level will be checked on a open test site and measuring distance is 3 m from EUT to receiver antenna.
- ③ For emission frequencies measured below 1 GHz, set the Test Receiver on a 120 KHz resolution bandwidth using measurement instrumentation employing a CISPR quasi-peak detector. and for above 1 GHz set the spectrum analyzer on a 1 MHz resolution bandwidth with average and peak detector for each frequency measured in step② and then EUT is located Position X,Y,Z on turn table (in this EUT is only Y axis)
- ④ The search antenna is to be raised and lowered over a range from 1 to 4 meters in horizontally polarized orientation. Position the highness when the highest value is indicated on spectrum analyzer, then change the orientation of EUT on test table over a range from 0° to 360° with a speed as slow as possible, and keep the highest emission is indicated on the spectrum analyzer. Vary the antenna position again and record the highest value as a final reading.
- ⑤ Repeat step④ until all frequencies to be measured were complete.
- ⑥ Repeat step⑤ with search antenna in vertical polarized orientations.
- ⑦ Check the frequencies of highest emission with varying the placement of cables (if any) associated with EUT to obtain the worst case and record the result.

The measurement results are obtained as described below:

$$\text{Result(dB}\mu\text{V/m)} = \text{Reading(dB}\mu\text{V/m)} + \text{Antenna factor(dB/m)} + \text{CL(dB)} + \text{other applicable factor (dB)}$$

5.6.4 Measurement Uncertainty

All measurements involve certain levels of uncertainties, especially in field of EMC. The factors contributing to uncertainties are test receiver, Cable loss, Antenna factor calibration, antenna directivity, antenna factor variation with height, antenna phase center variation, Antenna frequency interpolation, measurement distance variation, Site imperfection, mismatch, and system repeatability based on NIS 80,81, The measurement uncertainty level with a 95 % confidence level were apply to Uncertainty of a radiation emissions measurement at OATS(Open Area Test Site) of KOSTEC is ± 4.0 dB

5.6.5 Test Configuration

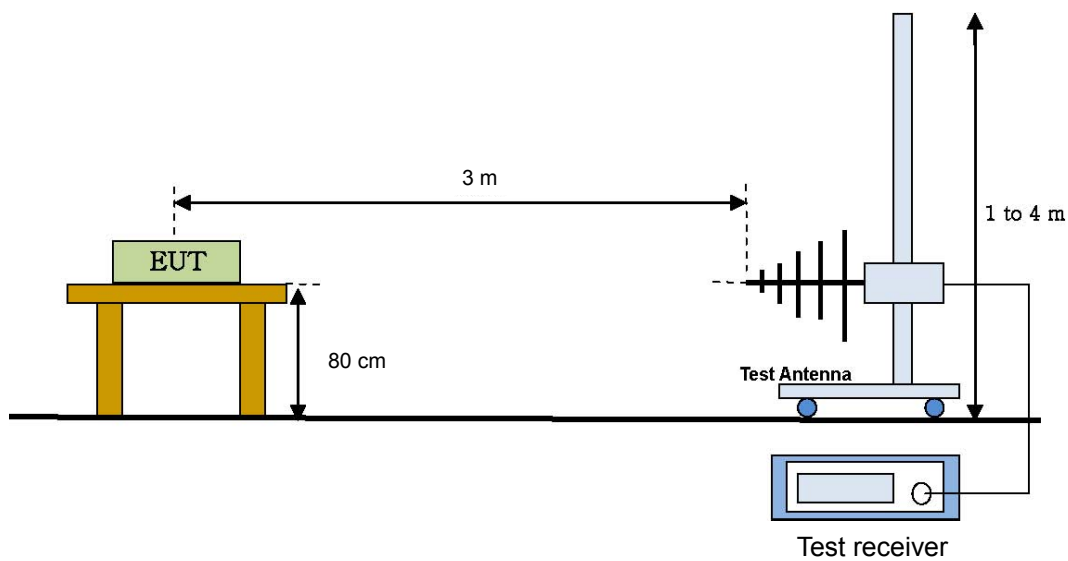

※ In case of above 1 GHz is using the Horn antenna instead of Broadband Antenna

[Radiated emission setup]

5.6.6 Measurement Result

▣ Lowest Channel_01 (2 402 MHz)

Below 1 GHz

Freq. (MHz)	Reading (dB μ V/m)	Table (Deg)	Antenna			CL (dB)	Pre AMP (dB)	Meas Result (dB μ V/m)	Limit (dB μ V/m)	Mgn (dB)	Result
			Height (m)	Pol. (H/V)	Fctr. (dB/m)						
648.56	34.75	185	1.9	V	17.72	8.51	25	35.98	46.02	10.04	Pass
Above 648.56	Nil emission										

Above 1 GHz

Freq. (MHz)	Reading (dB μ V/m)	Table (Deg)	Antenna			CL (dB)	Pre AMP (dB)	Meas Result (dB μ V/m)	Limit (dB μ V/m)	Mgn. (dB)	Result
			Height (m)	Pol. (H/V)	Fctr. (dB/m)						
1,125	34.56	105	1.5	H	24.71	2.52	25	36.79	54	17.21	Pass
1,125	42.84	105	1.5	H	24.71	2.52	25	45.07	74	28.93	Pass
4,804	26.50	120	1.6	V	32.07	5.25	25	38.82	54	15.18	Pass
4,804	35.53	120	1.6	V	32.07	5.25	25	47.85	74	26.15	Pass
Above 4,804	Nil emission										

※ Above 1 GHz is measured average and peak detector mode on Spectrum analyzer in accordance with FCC Rule 15.35

※ Limit: 54dB μ V/m(Average), 74dB μ V/m(Peak)

Freq.(MHz) : Measurement frequency, Reading(dB μ V/m) : Indicated value for test receiver,
Table (Deg) : Directional degree of Turn table,
Antenna (Height, Pol, Fctr) : Antenna Height, Polarization and Factor
Cbl(dB) : Cable loss, Pre AMP(dB) : Preamplifier gain(dB)
Meas Result (dB μ V/m) : Reading(dB μ V/m)+ Antenna factor.(dB/m) + CL(dB) - Pre AMP(dB)
Limit(dB μ V/m): Limit value specified with FCC Rule, Mgn(dB) : FCC Limit (dB μ V/m) – Meas Result(dB μ V/m),

▣ Middle Channel_ 38 (2 439 MHz)

Below 1 GHz

Freq. (MHz)	Reading (dB μ V/m)	Table (Deg)	Antenna			CL (dB)	Pre AMP (dB)	Meas Result (dB μ V/m)	Limit (dB μ V/m)	Mgn (dB)	Result
			Height (m)	Pol. (H/V)	Fctr. (dB/m)						
725.40	35.64	115	1.8	H	16.98	8.48	25	36.10	46.02	9.92	Pass
Above 725.40	Nil emission										

Above 1 GHz

Freq. (MHz)	Reading (dB μ V/m)	Table (Deg)	Antenna			CL (dB)	Pre AMP (dB)	Meas Result (dB μ V/m)	Limit (dB μ V/m)	Mgn. (dB)	Result
			Height (m)	Pol. (H/V)	Fctr. (dB/m)						
1,104	32.47	105	1.5	H	23.90	2.46	25	33.83	54	20.17	Pass
1,104	41.03	105	1.5	H	23.90	2.46	25	42.39	74	31.61	Pass
4,878	27.06	95	1.5	V	32.12	5.63	25	39.81	54	19.14	Pass
4,878	36.02	95	1.5	V	32.12	5.63	25	48.77	74	25.23	Pass
Above 4,878	Nil emission										

※ Above 1 GHz is measured average and peak detector mode on Spectrum analyzer in accordance with FCC Rule 15.35

※ Limit: 54dB μ V/m(Average), 74dB μ V/m(Peak)

■ Highest Channel_77 (2 478 MHz)

Below 1 GHz

Freq. (MHz)	Reading (dB μ V/m)	Table (Deg)	Antenna			CL (dB)	Pre AMP (dB)	Meas Result (dB μ V/m)	Limit (dB μ V/m)	Mgn (dB)	Result
			Height (m)	Pol. (H/V)	Fctr. (dB/m)						
894.50	32.88	115	1.8	H	17.24	9.15	25	34.27	46.02	11.75	Pass
Above 894.50	Nil emission										

Above 1 GHz

Freq. (MHz)	Reading (dB μ V/m)	Table (Deg)	Antenna			CL (dB)	Pre AMP (dB)	Meas Result (dB μ V/m)	Limit (dB μ V/m)	Mgn. (dB)	Result
			Height (m)	Pol. (H/V)	Fctr. (dB/m)						
1, 250	34.67	115	1.5	H	24.75	5.62	25	40.04	54	13.96	Pass
1, 250	42.92	115	1.5	H	24.75	5.62	25	48.29	74	25.71	Pass
4,956	25.63	104	1.6	V	33.10	5.98	25	39.71	54	14.29	Pass
4,956	34.67	104	1.6	V	33.10	5.98	25	48.75	74	25.25	Pass
Above 4,956	Nil emission										

※ Above 1 GHz is measured average and peak detector mode on Spectrum analyzer in accordance with FCC Rule 15.35

※ Limit: 54dB μ V/m(Average), 74dB μ V/m(Peak)

Freq.(MHz) : Measurement frequency, Reading(dB μ V/m) : Indicated value for test receiver,
Table (Deg) : Directional degree of Turn table,

Antenna (Height, Pol, Fctr) : Antenna Height, Polarization and Factor

Cbl(dB) : Cable loss, Preampifier gain(dB)

Meas Result (dB μ V/m) : Reading(dB μ V/m)+ Antenna factor.(dB/m) + CL(dB) - Pre AMP(dB)

Limit(dB μ V/m): Limit value specified with FCC Rule, Mgn(dB) : FCC Limit (dB μ V/m) – Meas Result(dB μ V/m),

5.7 Antenna requirement

5.7.1 Standard applicable

For intentional device, according to §15.203, an intentional radiator shall be designed to ensure that no antenna other than furnished by responsible party shall be used with the device.

The use of a permanently attached antenna or of an antenna that user a unique coupling to the intentional radiator shall be considered sufficient to comply with the provisions of this section.

The manufacturer may design the unit So that broken antenna can be replaced by the user, but the Use of a standard antenna jack or electrical connector is prohibited.

And according to, the conducted output power limit specified in paragraph(b) of this section §15.247 is based on the use of antennas with directional gains that do not exceed 6dBi.

According to above requirement standard's This product's antenna type is an Chip and it's gain is 0.58dBi, (In-band) So, antenna gain in this product is below requirement standard limit

5.7.2 Antenna gain

Frequency Band	Gain [dBi]	Limit [dBi]	Results
2 402 MHz – 2 478 MHz	0.58	≤ 6	Compliance

5.8 AC Power Conducted emissions

5.8.1 Standard Applicable [FCC §15.207(a)]

For intentional radiator that is designed to be connected to the public utility(AC)power line, the radio frequency Voltage that is conducted back onto the AC power line on any frequencies hopping mode within the band 150kHz to 30 MHz shall not exceed the limits in the following table, as measured using a 50uH/50 ohms line Impedance stabilization network(LISN). Compliance with the provisions of this paragraph shall be based on The measurement of the radio frequency voltage between each power line and ground at the power terminal. The lower limit applies at the boundary between the frequency ranges.

§15.207 limits for AC line conducted emissions;

Frequency of Emission(MHz)	Conducted Limit (dB μ V)	
	Quasi-peak	Average
0.15 ~ 0.5	66 to 56 *	56 to 46 *
0.5 ~ 5	56	46
5 ~ 30	60	50

* Decreases with the logarithm of the frequency

5.8.2 EUT used cable

Cable Type	Shield	Length (m)	Ferrite	Connector	Connection Point 1	Connection Point 2
RJ-11	No	0.5	No	No	E.U.T.	Telephone (Headset)
RJ-11	No	0.5	No	No	E.U.T.	Telephone (Base)
RJ-45	Yes	1.0	No	No	E.U.T.	Note book PC

5.8.3 Operating conditions

The operating mode/system was as follows in details:

Establish of BT communication link between Headset(EUT) and Mobile phone under the battery charging mode through USB connection. The mobile phone was set up with send to continuous calling (Inquiry mode) In order to search on BT device, So BT is Answer mode on frequencies band (2 402 MHz ~ 2 480 MHz)

5.8.4 Used Peripherals

Description	Manufacturer	Model / Part No	Serial Number
Note book PC	Dell Inc.	PP25L	CN-OXN850-48661-84P-25QH
Adaptor	Electronics (JIANG SU,. LTD)	DA65NS4-00	CN-OU8042-70166-87 G-0AIL

5.8.5 E.U.T Test Configuration

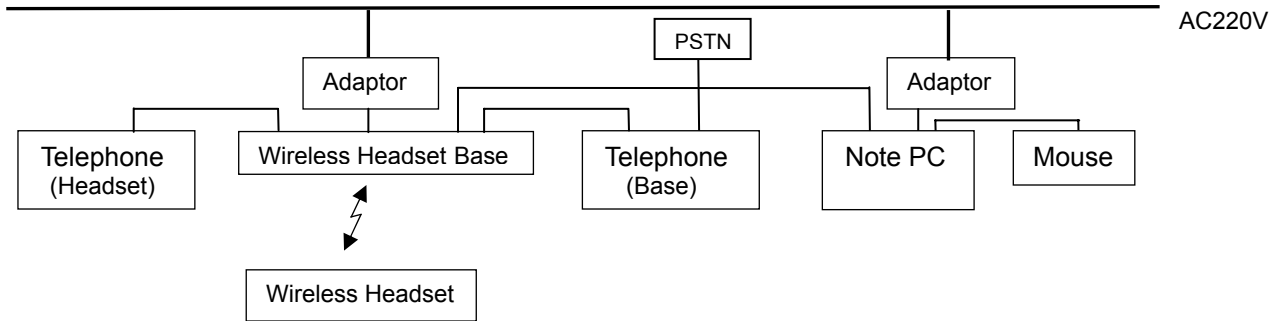

5.8.6 Measurement Procedure

A pretest was performed at 3 m distances in a semi-anechoic chamber for searching correct Frequency.

The final test was done at a 10 m open area test site with a quasi-peak detector. EUT was placed on a non-metallic table height of 0.8 m above the reference ground plane. Cables connected to EUT were fixed to cause maximum emission. Test was made with the antenna positioned in both the horizontal and vertical planes of polarization.

The measurement antenna was varied in height above the conducting ground plane to obtain the Maximum signal strength.

5.8.7 Test Data

FREQ. (MHz)	LEVEL(dB μ V)		LINE Pol	Loss (dB)	LIMIT(dB μ V)		MARGIN(dB)	
	QP	AV			QP	AV	QP	AV
0.154	37.16	33.99	L	0.08	65.36	55.36	28.20	21.37
0.182	36.84	31.94	L	0.08	63.53	53.53	26.69	21.59
0.290	38.83	35.22	N	0.29	61.12	51.12	22.29	15.90
0.738	23.52	19.50	N	0.43	56.00	46.00	32.48	26.50
1.066	28.49	25.94	N	0.44	56.00	46.00	27.51	20.06
2.046	21.78	19.86	N	0.57	56.00	46.00	34.22	26.14
7.798	16.29	15.81	L	1.20	60.00	50.00	43.71	34.19
13.610	13.93	10.52	N	1.61	60.00	50.00	46.07	39.48
22.578	27.75	26.18	N	1.94	60.00	50.00	32.25	23.82

* Note: Measurement uncertainty ; ± 2.4 dB ($K=2$)

■ Conducted Emission test graph

Line. Live

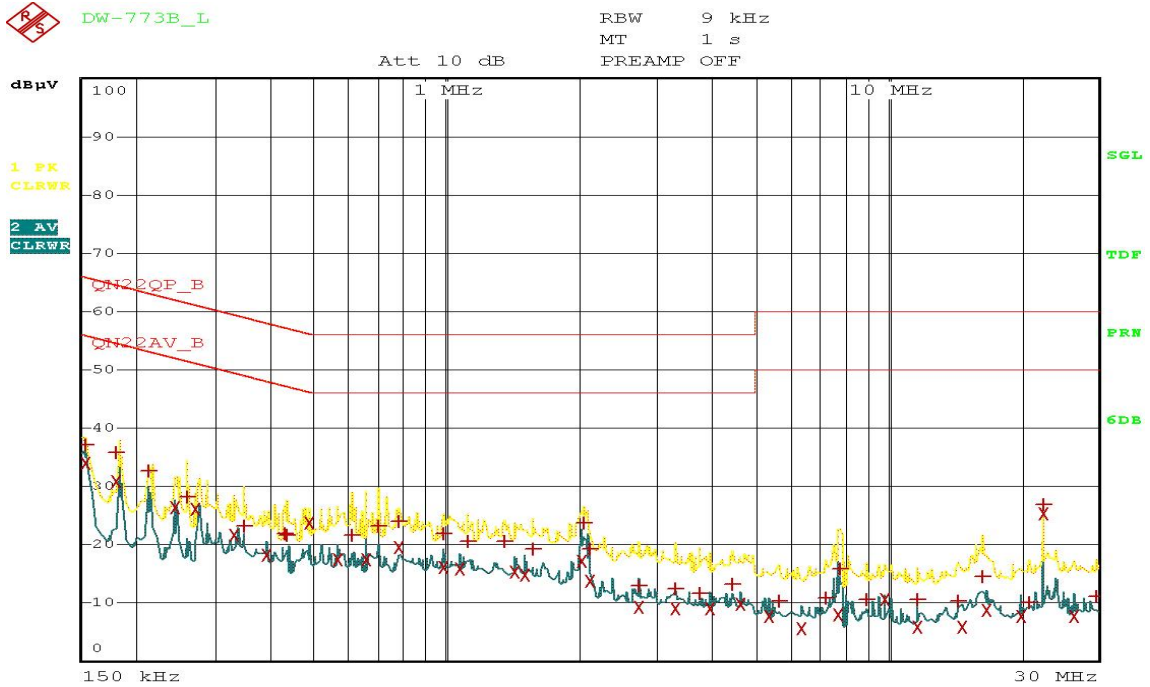

Line. Neutral

