

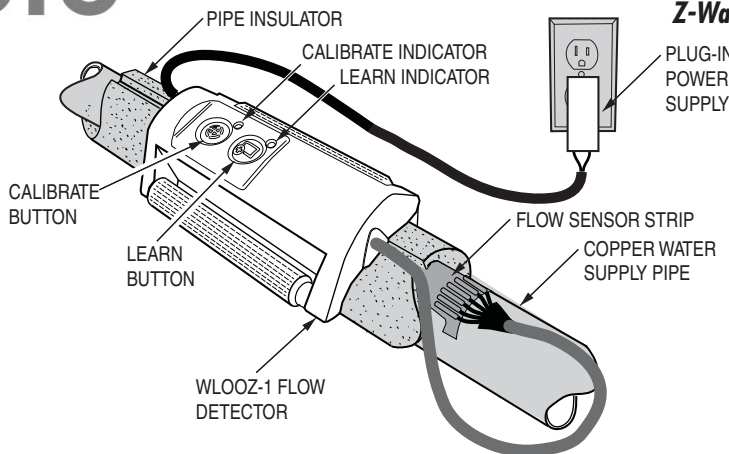

GoControl™

WL00Z-1

Z-Wave Radio Frequency (RF) Controlled Pipe Mounted Flow Detector



NOTE: This unit must be added to the Network **only where it will be permanently installed.** The proper operation of this node in the **mesh network** is dependent on it knowing its location with respect to other nodes. You cannot "test bench" configure this unit, then install.

GOCONTROL SMART Flow detector

The GoControl™ family of Z-Wave® certified wireless lighting products (smart LED bulbs, switches, dimmers, outlets, plug-in modules), security devices (alert sounder, motion sensor, and door/window sensor), and control products (garage door controller and thermostat) bring a new level of intelligent wireless capability to commercial and residential environments.

The Z-Wave wireless protocol is an international wireless standard for remote home automation, security and other applications. Embedded in each device, the Z-Wave smart chip enables two-way RF communication among hundreds of Z-Wave enabled devices, allowing products and services from multiple manufacturers to work seamlessly.

The FlowZ WL00Z-1 Smart Flow detector is simple to set up and provides whole house monitoring of water flow that can alert you to catastrophic water leaks like slab leaks, cracked pipes or a chronically running faucet.

GoControl Z-Wave products are easy to install, are Z-Wave Plus certified, and allow dealers to create an integrated wireless network with nearly limitless expansion and interoperability with security, energy management, home entertainment, appliances, and more.

As part of a Z-Wave network, the WL00Z-1 will also act as a wireless repeater to insure that commands intended for another device in the network are received. This is useful when the device would otherwise be out of the radio range of the wireless controller.

For indoor use only. Retain instructions for future use.

Z-WAVE PLUS FEATURES

The WL00Z-1 contains a Z-Wave 500 Series Module that supports Z-Wave Plus® features. A Z-Wave certified portable or stationary Controller can communicate with the Z-Wave 500 Series Module.

Depending on the capability of the Controller or gateway software, the following operations will be performed by Smart Flow Detector. Refer to the controller or gateway manual for details.

- Send an alert if water is running.
- Add or Remove Smart Flow Detector. Over-the-air firmware update by the gateway or static Controller.
- Lifeline function which automatically notifies the associated modules and the network that a manually reset device is no longer in the network, thus, the corresponding association becomes invalid.

Z-Wave® and Z-Wave Plus® are registered trademarks of Sigma Designs and its subsidiaries in the United States and other countries.

INSTALLATION

The WL00Z-1 Smart Flow detector module straps on a water pipe over the foam pipe insulator covering the stick-on sensor strip that directly contacts the pipe. The sensor strip that detects water flow plugs into the detector module. The detector module is powered by a UL Listed plug-in power supply that also plugs into the detector.

Pipe Preparation

1. Examine the water piping of the installation. Find the incoming line from the meter or the line to be monitored. **The WL00Z-1 must be installed indoors on a copper pipe 3/4 to 1" diameter.** Monitoring of PVC, cast iron, galvanized or any other type of pipe is not supported.
2. Determine the direction of the water flow through the pipe to be monitored.
3. Clean a 6" section of the pipe with the included abrasive cleaning pad. To ensure good contact with the flow sensor, be sure to clean completely around the pipe.

CLEAN A 6-INCH AREA OF THE WATER PIPE WHERE THE SENSOR STRIP WILL CONTACT THE PIPE

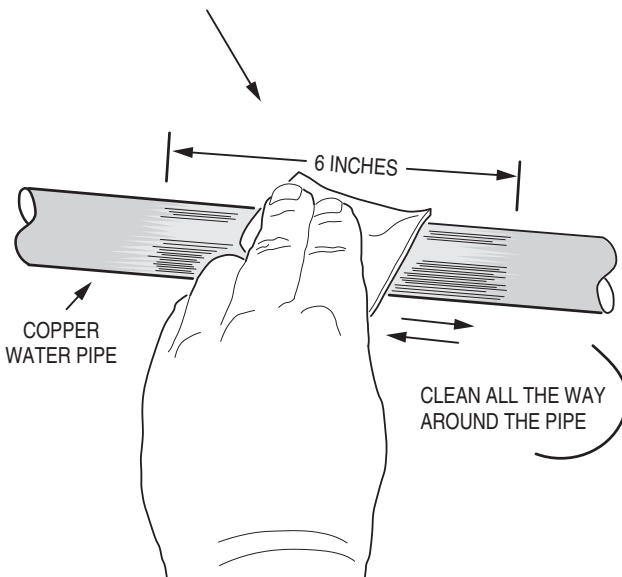

Flow Detector Installation

1. Look for the water flow direction arrow on the stick-on sensor strip.
2. Carefully peel off the stick-on sensor strip backing and affix the sensor strip long-wise to the cleaned off section of the pipe. **Be sure the water flow direction in the pipe matches the flow direction arrow on the sensor strip.**
3. Position the red silicone insulator completely over the sensor strip, then secure the insulator and sensor to the pipe with two evenly spaced wire ties (included).

Flow detector Module Installation

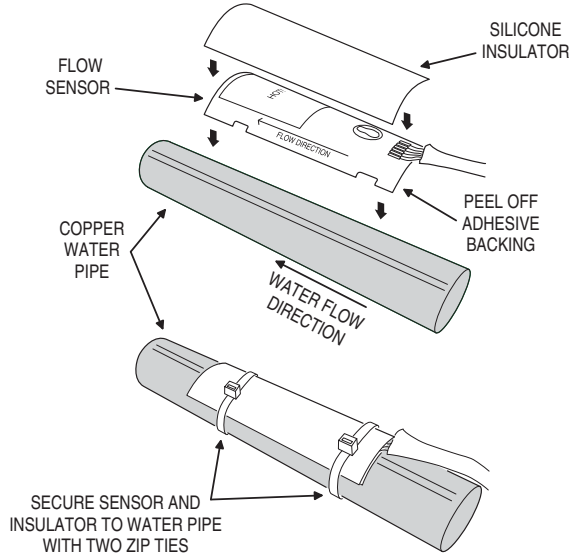

1. Fit the gray foam pipe insulator over the sensor assembly and onto the pipe with the sensor cable exiting one end of the pipe insulator.
2. Fit the flow detector over the gray foam pipe insulator.
3. Secure the flow detector to the pipe using the attached hook and loop strap.

Power Supply Installation

1. Insert the power supply connector into the power input plug on the side of the flow detector.
2. Plug the power supply into a *non-switched* 120 VAC outlet.
3. The green indicator on the flow detector should light.

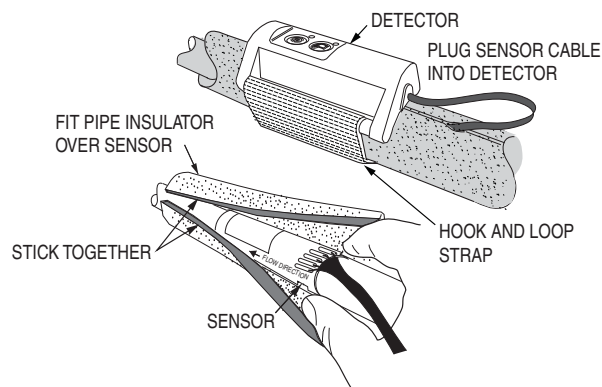

CALIBRATION

Before the flow detector can accurately measure the water flow in the monitored pipe, it will need to be calibrated. Perform the following steps to calibrate the unit.

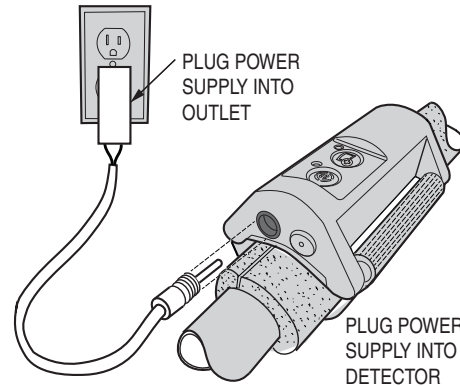

1. Turn off the water to the home by closing the incoming water line valve at nearest point to entry of home (typically the valve to turn off water is near where it enters the home).
2. Press the **CALIBRATE** button on the flow detector. The red and green indicators will alternatively blink every second.
3. Wait for the calibration process (about 30 seconds).
4. The system will confirm that the calibration is completed, by flashing the Green LED three (3) times and then staying on. If the calibration failed, the Red LED will flash three (3) times and stay Red.
5. Turn the water back on to the home.

OPERATION

Once installed and calibrated, the Smart Flow detector will continuously monitor the water flowing through the pipe. If water is running continuously at a rate of approximately ten (10) oz. per minute, an alert will be sent to the Z-Wave hub. The default Water Flow Time for the Smart Flow detector is 21 minutes.

You can change the Water Flow Time from 14 to 350 minutes (see Configuration). The Smart Flow detector will send an alert based on the Water Flow Time with a variation of up to seven (7) minutes. So out of the box, the Smart Flow detector will send an alert if water is flowing for 21 to 28 minutes. If the Water Flow Time is changed to 14 minutes, an alert will be sent between 14 and 21 minutes.

✓ *Note: It may take up to seven (7) minutes for a water flowing alert to be cleared.*

✓ *Note: This product should be tested periodically to make sure it is working properly. The product, if used properly, may reduce the risk of water damage. However it may fail to warn for a variety of reasons, including, but not limited to improper installation or positioning, improper maintenance, component failures, Z-Wave communication failures, water flow may be outside of the product's designed range of ten (10) oz. per minute and certain environmental conditions may impact performance.*

Z-WAVE PROGRAMMING

Adding to a Network:

Refer to your Controller operating instructions to add this device under the command of the Wireless Controller.

6. With your Controller in Discovery or Add Mode, press the **LEARN** button. The green indicator will blink slowly.
7. When the Smart Flow Detector is added, the green indicator will blink quickly three times, then stay on.
8. You should see an indication on your Controller that the “device was added” to the network and the green indicator will turn off.
9. The device will appear in the list of sensors at the hub.

If the Controller/Gateway shows the addition failed, the red indicator will flash three times then stay on. If this occurs, repeat Steps 1-3.

✓ **NOTE:** If you have trouble adding the WL00Z-1 to a group it may be that the Home ID and Node ID were not cleared from it after testing. You must first “RESET UNIT” to remove it from the network. Although adding it to a group includes it in the network, removing it from a group does not remove it from the network. If removed from a group, it functions as a repeater (only). “RESET UNIT” removes it completely from the network.

To Reset Unit (If Required):

In the event that your primary Controller is lost or otherwise inoperable, to reset the WL00Z-1 and clear all network information, follow these steps:

1. Press the **LEARN** button five (5) times quickly. The green indicator will start to blink quickly.
2. Immediately press and hold the **CALIBRATION** button for 15 seconds.
3. The green indicator will turn off when the reset is successful.

Removing from a Network:

The WL00Z-1 can be removed from the network by the Controller/Gateway. Refer to the Controller operating instructions for details.

1. Set the Controller into Removal Mode.
2. Press the **LEARN** button.
3. The green indicator will begin to blink slowly. When the Smart Flow Detector is successfully removed, the green indicator will blink quickly three times then stay on.
4. You should see an indication on your Controller that the device was removed from the network.

✓ **NOTE:** If the Controller/Gateway shows the remove failed, the red indicator will flash three times and stay on. If this occurs, repeat Steps 1-3.

CONFIGURATION

The WL00Z-1 supports the Configuration command. It can be configured to operate slightly differently than how it works when you first install it.

Using the Configuration command you can configure the following:

Flow Detection Alert Timing

By default, the WL00Z-1 will send an alert after approximately 21 minutes of continuous water flow.

The length of time for continuous water flow before an alert is sent can be set to a minimum of 14 minutes and a maximum of 350 minutes by using the Configuration Command Class, Parameter 0.

By default, the WL00Z will send an alert when water is running from 21 to 27minutes.

Parameter	Length	Valid Values	Configuration Option
0	2 Bytes	2 to 50 in whole number increments. Default =3	Alert is sent when water is flowing for x 7 + 7minutes

Associations

The WL00Z-1 supports one level of Z-Wave association.

Group 1 association is used to identify another Z-Wave device in the network that will receive unsolicited state changes and notification (alarm) events.

For instructions on how to “set lifeline association” please refer to your wireless controller instructions.

INDICATOR LEGEND

GREEN INDICATOR	RED INDICATOR	DESCRIPTION
Solid	Off	Powered on with no error conditions. (Note: the unit can be uncalibrated and/or unpaired in this state)
Blinks every second	Off	Indicates the WL00Z-1 is in the process on Learning or Unlearning into a Z-Wave network.
Fast blink (200ms) for 3 seconds, then Solid	Off	Indicates the WL00Z-1 succeeded Learning or Unlearning into a Z-Wave network.
Super fast (100ms) blink	Off	This is the result of tapping the Learn button 5 times within 2 seconds to initiate a Z-Wave reset of the WL00Z-1 This is the first step, the second step is to then hold down the Calibrate button for 15 seconds. If the Calibrate button is not held down during this state, it will end after 5 seconds.
Solid	Blink every second	The WL00Z-1 detects water flowing.
Blink every 400ms, alternately with Red LED	Blink every 400ms, alternately with Green LED	Indicates the WL00Z-1 is in the process of Calibration.
Off	Solid	Indicates the last action performed by the WL00Z-1 failed. This can be Learn or Unlearn into the Z-Wave network, or a failed Calibration.
Off	Blink every second	The WL00Z-1 detects water flowing, after the last action performed by the WL00Z-1 failed.
Off	Fast blink (200ms) for 3 seconds, then Solid	Indicates the WL00Z-1 failed Learning or Unlearning into a Z-Wave network.

SPECIFICATIONS

Power: 120 VAC, 60 Hz Input, 14V 1700 mA Output
Signal (Frequency): 908.42 MHz / 916 MHz
Range: Up to 130 feet line of sight

REGULATORY INFORMATION

The WL00Z-1 is certified to comply with applicable FCC and IC rules and regulations governing RF and EMI emissions. This device complies with part 15 of the FCC Rules. Operation is subject to the following two conditions: (1) This device may not cause harmful interference, and (2) This device must accept any interference received, including interference that may cause undesired operation.

FCC Notice

This equipment has been tested and found to comply with the limits for a Class B digital device, pursuant to Part 15 of the FCC Rules. These limits are designed to provide reasonable protection against harmful interference in a residential installation.

This equipment generates, uses, and can radiate radio frequency energy and, if not installed and used in accordance with the instructions may cause harmful interference to radio communications. However, there is no guarantee that interference will not occur in a particular installation. If this equipment does cause harmful interference to radio or television reception, which can be determined by turning the equipment off and on, the user is encouraged to try to correct the interference by one or more of the following measures:

- Reorient or relocate the receiving antenna.
- Increase the separation between the equipment and receiver
- Connect the equipment into an outlet on a circuit different from that to which the receiver is connected
- Consult the dealer or an experienced radio/TV technician to help.
- Changes or modifications not expressly approved by the party responsible for compliance could void the user's authority to operate the equipment

IC Notice

This Class B digital apparatus complies with Canadian ICES-003

Cet appareil numérique de la classe B est conforme à la norme NMB-003 du Canada. Le présent appareil est conforme aux CNR d'Industrie Canada applicables aux appareils radio exempts de licence. L'exploitation est autorisée aux deux conditions suivantes : (1) l'appareil ne doit pas produire de brouillage, et (2) l'utilisateur de l'appareil doit accepter tout brouillage radioélectrique subi, même si le brouillage est susceptible d'en compromettre le fonctionnement.

This device complies with the Industry Canada license exempt RSS standard(s). Operation is subject to the following two conditions: (1) this device may not cause interference, and (2) this device must accept any interference, including interference that may cause undesired operation of the device.

WARRANTY

What is Covered?

Nortek Security & Control ("NS&C") warrants to consumers who purchase this product for personal, family or household purposes new from NS&C directly or from an authorized NS&C dealer, that the product will be free from defects in materials and workmanship for a period of (1) year from the date of purchase. This warranty only applies if the product is installed at a residence in the 50 United States or District of Columbia, and only at the site of the original installation. It is not transferable. This warranty is not extended to resellers.

If a defect exists, NS&C will have you ship the defective part or product to us and we will, at our option, either repair or replace it. This warranty does **not** cover the cost of labor to remove a defective part or product or to reinstall any repaired or replacement part or product.

This warranty does **not** cover defects or damages caused by improper handling, maintenance, storage, installation, removal or re-installation, misuse, non-factory authorized modification or alteration, use of incompatible accessories, electrical power problems or surges, impact by foreign objects, accident, fire, acts of God, normal wear and tear or shipping damage other than a shipment from NS&C. Note that all NS&C products are designed to be installed, removed and serviced by trained individuals or professionals.

Keep your original sales receipt as it will be required to obtain warranty service.

This warranty shall not be extended or restarted upon receipt of any repaired or replacement part or product under this warranty. No person is authorized to extend or otherwise modify this warranty.

How do I Obtain Warranty Service?

To obtain warranty service, email our Returns Department at returns@nortek.com. Include your name, address, telephone number, the model number of your product, a copy of your original sales receipt, and a description of the problem. Unless we need to discuss the situation further with you, you will be emailed a Return Authorization Number and shipping instructions. If we need to discuss the situation further with you, we will call or email you. NS&C may require troubleshooting on installed product before a Return Authorization Number is issued. Anything shipped to us without a Return Authorization Number will be automatically returned unopened. You are responsible for the charges for shipment to us, unless you are a California resident.

Limitations

THE DURATION OF ANY IMPLIED WARRANTY, INCLUDING THE WARRANTIES OF MERCHANTABILITY AND FITNESS FOR A PARTICULAR PURPOSE, SHALL NOT EXCEED THE WARRANTY PERIOD PROVIDED HEREIN.

Some states do not allow limitations on how long an implied warranty lasts, so the above limitation may not apply to you.

NS&C SHALL NOT BE LIABLE FOR ANY INCIDENTAL OR CONSEQUENTIAL DAMAGES RESULTING FROM THE BREACH OF ANY WRITTEN OR IMPLIED WARRANTY.

Some states do not allow the exclusion or limitation of incidental or consequential damages, so the above limitation or exclusion may not apply to you.

This warranty gives you specific legal rights, and you may also have other legal rights which vary from State to State.

IMPORTANT !!!

Radio controls provide a reliable communications link and fill an important need in portable wireless signaling. However, there are some limitations which must be observed.

- For U.S. installations only: The radios are required to comply with FCC Rules and Regulations as Part 15 devices. As such, they have limited transmitter power and therefore limited range.
- A receiver cannot respond to more than one transmitted signal at a time and may be blocked by radio signals that occur on or near their operating frequencies, regardless of code settings.
- Changes or modifications to the device may void FCC compliance.
- Infrequently used radio links should be tested regularly to protect against undetected interference or fault.
- A general knowledge of radio and its vagaries should be gained prior to acting as a wholesale distributor or dealer, and these facts should be communicated to the ultimate users.

GoControl™

 **NORTEK**
SECURITY & CONTROL
USA & Canada (800) 421-1587 & (800) 392-0123
(760) 438-7000 - Toll Free FAX (800) 468-1340
www.nortekcontrol.com