

## Operating Instructions

The 2GIG-DW21R-345 is the industry's most flexible supervised recessed door/window contact, allowing a multitude of applications while hiding the transmitter within a door or window frame. The 2GIG-DW21R-345 uses a replaceable lithium battery and should last 5 years under normal usage.

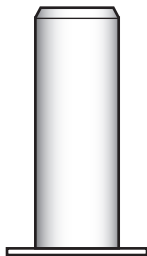

### Installation & Mounting Guidelines

It is important to select the proper placement of the recessed transmitter and magnet. The transmitter comes with two different tops, however, the screw mount is recommended for securing the sensor to the door frame. The magnet does not have a second top with a flange to screw it into place so you must be extra careful to ensure that the magnet is tightly in place once installed.

- 1 Install the recommended battery if it is not already installed (see Battery Installation & Replacement).
- 2 Select a location on the door or window frame for the 2GIG-DW21R-345 transmitter and magnet to be installed. Use a marker to mark and ensure that the two holes you intend to drill are lined up directly across from each other.
- 3 Using a 3/4" drill bit, slowly drill the first hole for the transmitter. The 2GIG-DW21R-345 was specifically designed to be slightly larger than a 3/4" hole so you will need to carefully drill to fit by slowly routing the hole little by little to ensure a snug fit. Use the flanged cap and use the included screws for mounting the transmitter to the door or window frame.
- 4 Drill the matching hole for the magnet directly opposite from the transmitter in the door, also using a 3/4" drill bit.

### Programming

2GIG panels allow a tamper to be sent to 'LEARN' the serial code of the transmitter. The 2GIG-DW21R-345 sends a tamper Fault and Restore when the battery is installed. To learn the contact into a 2GIG panel, insert the battery while the panel is in 'LEARN' mode. If inserting the battery does not learn in the contact to the panel, use the supplied magnet to learn in the contact.

### Testing

Before mounting the sensor, verify that the sensor mounting location provides good RF communication to the panel. To verify, do the following:

1. Put the control panel into sensor test mode.
2. Hold the magnet next to the removable cap on the sensor and then pull the magnet away from the sensor.
3. Listen for siren or keypad beeps to determine appropriate response (refer to the control panel Installation instructions).
4. Exit sensor test mode.

Note: It is recommended that a system test be performed per the Operation & User's Guide at least once a year.

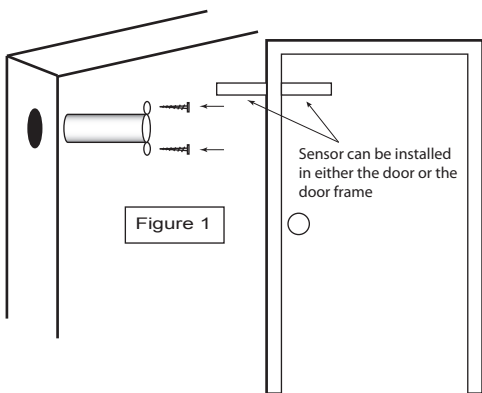

**CAUTION:**  
Do not apply any pressure on the glass reed switch

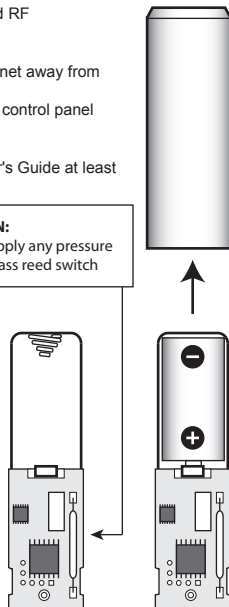

## Battery Installation & Replacement

Use a screw driver to turn and open the top of the 2GIG-DW21R-345 to change tops or access the battery. If the double screw top is used to attach the unit to the door frame, remove both screws, turn the top counterclockwise and then pull the board and battery out. Remove the old battery and replace with a new one. Use care when installing the battery and observe the correct polarity when the battery is inserted (see Figure 2). Use only the recommended replacement batteries (see Specifications). **DO NOT APPLY PRESSURE ON THE GLASS REED SWITCH.**

**WARNING! The polarity of the battery must be observed, as shown (see Figure 2). Improper handling of lithium batteries may result in heat generation, explosion or fire, which may lead to personal injuries. Replace only with the same or equivalent type of battery as recommended by the manufacturer (see Specifications).**

**Batteries must not be recharged, disassembled or disposed of in fire.** Disposal of used batteries must be made in accordance with the waste recovery and recycling regulations in your area.

Keep away from small children. If batteries are swallowed, promptly seek medical attention.

**California Only:** This Perchlorate warning applies only to Manganese Dioxide Lithium cells sold or distributed ONLY in California, USA. Perchlorate Material-special handling may apply. See [www.dtsc.ca.gov/hazardouswaste/perchlorate](http://www.dtsc.ca.gov/hazardouswaste/perchlorate).

## Specifications

Wireless Signal Range	450 ft., open air, with 2GIG Wireless Alarm Control Panel
Code Outputs	Alarm; Alarm Restore; Supervisory; Low Battery
Transmitter Frequency	345.000 MHz (crystal controlled)
Transmitter Frequency Tolerance	±15kHz
Transmitter Bandwidth	24kHz
Modulation Type	Amplitude Shift Keying-On/Off Keying (ASK-OOK)
Unique ID Codes	Over one (1) million different code combinations
Supervisory Interval	70 minutes
Peak Field Strength	Typical 50,000 uV/m at 3m
Reed Switch Magnetic Sensitivity	10 to 20 amp turns
Reed Sensitivity	0.625 in. (1.59 cm) minimum gap, 0.85 in. (2.16 cm) typical
Magnet Type	Rare earth
Magnet Dimensions (Hx~)	0.5 x 0.75 in. (1.27 x 1.9 cm)
Sensor Dimensions (HxD)	2.57 x 0.75 in. (6.53 x 1.9 cm)
Weight (Including battery & magnet)	1.25 oz. (35.4 g)
Housing Material	ABS plastic
Color	White
Operating Temperature	32° to 120°F (0° to 49°C)
Relative Humidity	5-95% Non-Condensing
Battery (Included, not Installed)	one (1) Panasonic CR2, or equivalent Lithium battery
Regulatory Listing(s)	ETL, FCC Part 15, Industry Canada
Warranty*	Two (2) years
Included Accessories	Included Accessories Two magnetic cap styles (Normal and Screw type), two (2) Phillip's flat-head screws

## FCC & INDUSTRY CANADA REGULATORY INFORMATION

FCC ID: WDQ-DW21345  
Industry Canada ID: 7794A-DW21345

NOTICE: Unauthorized changes or modifications could void the user's authority to operate the equipment.

This device complies with Part 15 of the FCC Rules and Industry Canada licence-exempt RSS standard(s). Operation is subject to the following two conditions: (1) This device may not cause harmful interference, and (2) this device must accept any interference received, including interference that may cause undesired operation of the device.

Le présent appareil est conforme aux CNR d'Industrie Canada applicables aux appareils radio exempts de licence. L'exploitation est autorisée aux deux conditions suivantes : (1) l'appareil ne doit pas produire de brouillage, et (2) l'utilisateur de l'appareil doit accepter tout brouillage radioélectrique subi, même si le brouillage est susceptible d'en compromettre le fonctionnement.

This equipment has been tested and found to comply with the limits for a Class B computing device, pursuant to Part 15 of FCC Rules. These limits are designed to provide reasonable protection against harmful interference in a residential installation. This equipment generates uses and can radiate radio frequency energy and if not installed and used in accordance with the instructions, may cause harmful interference to radio communications. However, there is no guarantee that interference will not occur in a particular installation. If this equipment does cause harmful interference to radio or television reception, which can be determined by turning the equipment off and on, the user is encouraged to try to correct the interference by one or more of the following measures:

- Reorient or relocate the receiving antenna.
- Increase the separation between the equipment and the receiver
- Connect the equipment into an outlet on a circuit different from that to which the receiver is connected.
- Consult the dealer or an experienced radio/television technician for help



©2011 2gig Technologies Inc. All Rights Reserved

Technical Support:  
1-866-670-1591  
[www.2gig.com](http://www.2gig.com)

PN 77-000003-001 Rev B