

2GIG-CO1-345

WIRELESS CARBON MONOXIDE ALARM

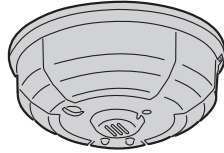

Installation Instructions



2gig technologies
 Technical Support
 866-670-1591
 www.2gig.com

PRODUCT DESCRIPTION

The 2GIG-CO1-345 is a carbon monoxide (CO) alarm with a built-in transmitter designed for use with the 2GIG-CNTRL-345 security system. The detector gives warning to alert against both the acute and chronic effects of CO poisoning. When carbon monoxide is detected, the alarm sounds a loud local alarm. When the local alarm sounds, the built-in transmitter sends a digitally coded wireless signal to the Control Panel every 20 seconds until the air has cleared and the detector is restored.

The 2GIG-CO1-345 detector can send four different signals: alarm, test, low battery, and status.

The local alarm can be silenced once by pressing the TEST/RESET button. The detector will continue to send an alarm signal every 20 seconds. After 7 minutes, the alarm will sound again if there is still an unsafe CO concentration level. The reset function can be used only once for each alarm occurrence.

The Control Panel must be programmed to the detector's serial number before system testing and operation. Refer to the Control Panel's instructions for details on programming.

The detector is powered by one 3-volt lithium battery. The battery is supplied with the detector and can power the unit for more than one year. If the battery voltage drops below a preset level the alarm will sound a low battery chirp every 45 seconds and a low battery signal will be sent to the Control Panel.

When the detector reaches the end of its serviceable life (after about 6 years) a permanent trouble condition will occur and cannot be reset.

Maintenance: Occasionally clean the outside casing with a cloth. Ensure that the holes on the front of the alarm are not blocked with dirt and dust. **Do not paint, and do not use cleaning agents, bleach, or polish on the detector.**

FEATURES

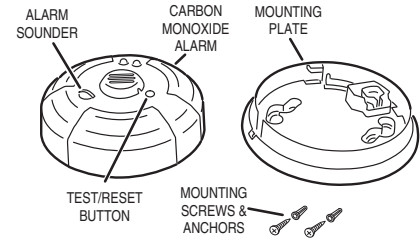

ALARM SIGNALS

NORMAL OPERATION	GREEN LED FLASHES EVERY 10 SECONDS.
ALARM SIGNAL	A REPEATING PATTERN OF FOUR SHORT BEEPS AND 5 SECOND SILENCE. THE RED LED WILL FLASH ONCE PER SECOND.
TROUBLE SIGNAL	DETECTOR SELF-TESTS EVERY 10 SECONDS. IF A FAULT IS DETECTED, RED LED WILL BLINK EVERY 5 SECONDS AND DETECTOR WILL BEEP EVERY 45 SECONDS. IN THIS CONDITION, THE DETECTOR REQUIRES IMMEDIATE REPLACEMENT.
LOW BATTERY SIGNAL	RED LED BLINKS EVERY 45 SECONDS. REPLACE THE BATTERY WHEN THIS SIGNAL OCCURS.
END-OF-LIFE SIGNAL	RED LED WILL BLINK ONCE EVERY 10 SECONDS AND DETECTOR WILL BEEP EVERY 45 SECONDS. IN THIS CONDITION, THE DETECTOR REQUIRES IMMEDIATE REPLACEMENT.

SELECT PROPER LOCATION

REFER TO SECTION NUMBER 5 ON THE REAR OF THESE INSTRUCTIONS FOR IMPORTANT MOUNTING DETAILS

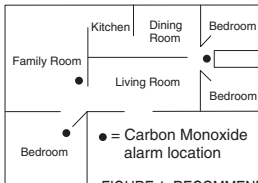

FIGURE 1. RECOMMENDED CO ALARM PLACEMENT FOR SINGLE FLOOR RESIDENCE

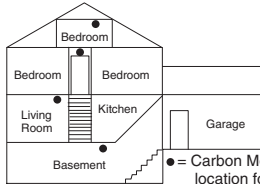
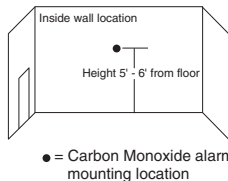

FIGURE 2. RECOMMENDED CO ALARM PLACEMENT FOR MULTI-LEVEL RESIDENCE

FIGURE 3. RECOMMENDED CO ALARM MOUNTING LOCATION IS 5 TO 6 FEET FROM FLOOR



REMOVE MOUNTING PLATE

TWIST MOUNTING PLATE TO UNLOCK

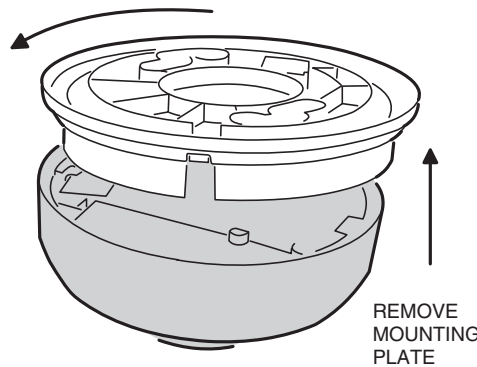

REMOVE BATTERY TAB

NOTE: ON POWER-UP THE RED AND GREEN LEDS WILL BLINK 4 TIMES, 15 SECONDS APART WHILE THE ALARM INITIALIZES.

REMOVE BATTERY TAB TO APPLY POWER

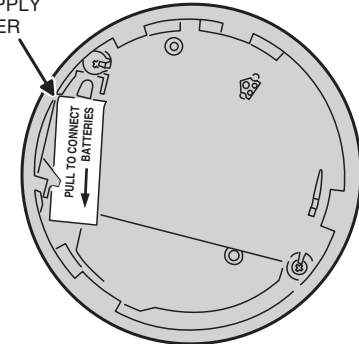

3-VOLT LITHIUM BATTERY - TYPES: DURACELL DL123A, PANASONIC CR123A, SANYO CR123A, ADEMCO 466. AVAILABLE AT LOCAL RETAILERS AND INTERNET SUPPLIERS. **NOTE: USE ONLY THESE SPECIFIC BATTERY MODELS.**

INSTALL MOUNTING PLATE

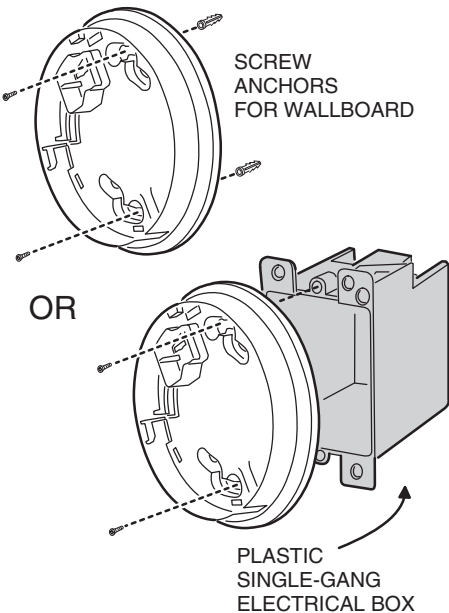

PROGRAM CONTROL PANEL

REFER TO CONTROL PANEL'S INSTRUCTIONS TO PREPARE RECEIVER TO ACCEPT THE DETECTOR'S SERIAL NUMBER

PRESS UNTIL ALARM BEEPS THEN RELEASE TEST BUTTON TO SEND SIGNAL

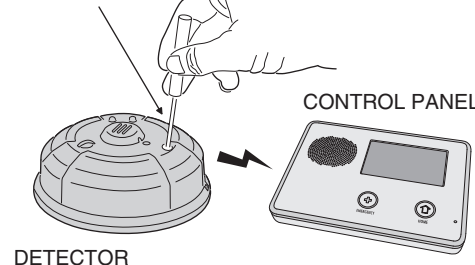

A TEST SIGNAL WILL BE SENT A FEW SECONDS AFTER THE SWITCH IS RELEASED

MOUNT ALARM ON PLATE

TWIST CO ALARM CLOCKWISE TO LOCK ONTO MOUNTING PLATE

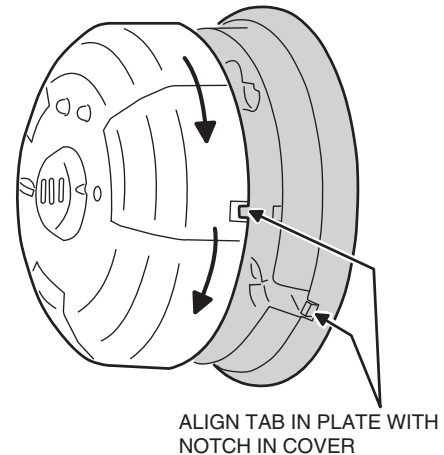

If alarm sounds:

- 1 Operate reset/silence button
- 2 Call your emergency services fire department or 911
- 3 Immediately move to fresh air – outdoors or by an open door/window. Then, do a head count to check that all persons are accounted for. Do not reenter the premises nor move away from the open door/window until the emergency services responders have arrived, the premises have been aired out, and your alarm remains in its normal condition.
- 4 After following steps 1 - 3, if your alarm reactivates within a 24-hour period, repeat steps 1 - 3 and call a qualified technician to investigate for sources of CO from fuel burning equipment and appliances, and inspect for proper operation of this equipment. If problems are identified during this inspection, have the equipment serviced immediately. Note any combustion equipment not inspected by the technician and consult the manufacturers' instructions or contact the manufacturers directly for more information about CO safety and this equipment. Make sure that motor vehicles are not and have not been operating in an attached garage or adjacent to the residence.

WARNING

ACTUATION OF YOUR CO ALARM INDICATES THE PRESENCE OF CARBON MONOXIDE (CO), WHICH CAN KILL YOU!

IMPORTANT INFORMATION

1.0 WHAT YOU SHOULD KNOW ABOUT CO

Carbon monoxide (CO) is an insidious poison. It is a colorless, odorless and tasteless gas. It is a cumulative poison. Even low levels of CO have been shown to cause brain and other vital organ damage in unborn infants with no effect on the mother.

The following symptoms are related to CARBON MONOXIDE POISONING and should be discussed with ALL members of the household:

- **MILD EXPOSURE:** Slight headache, nausea, vomiting, fatigue (often described as "flu-like" symptoms)
- **MEDIUM EXPOSURE:** Severe throbbing headache, drowsiness, confusion, fast heart rate
- **EXTREME EXPOSURE:** Unconsciousness, convulsions, cardiorespiratory failure, death

Many cases of reported CARBON MONOXIDE POISONING indicate that while victims are aware they are not well, they become so disoriented they are unable to save themselves by either exiting the building or calling for assistance. Also, young children and household pets may be the first affected.

Your CO alarm is designed to detect the toxic CO fumes that result from incomplete combustion, such as those emitted from appliances, furnaces, fireplaces and auto exhaust.

A CO Alarm is NOT A SUBSTITUTE for other combustible gas, fire or smoke alarms. This carbon monoxide alarm is designed to detect carbon monoxide gas from ANY source of combustion.

CAUTION: This alarm will only indicate the presence of carbon monoxide gas at the sensor. Carbon monoxide gas may be present in other areas.

WARNING: This product is intended for use in ordinary indoor locations of family living units. It is not designed to measure compliance with Occupational Safety and Health Administration (OSHA) commercial or industrial standards. Individuals with medical problems may consider using warning devices which provide audible and visual signals for carbon monoxide concentrations under 30 ppm.

2.0 IMPORTANT CONSIDERATIONS

- **2.1** The 2GIG-CO1-345 has been designed to operate for six years with regular maintenance.
- **2.2** Never disconnect the battery to silence an alarm. The alarm will automatically sense when the level of CO in the air falls below the danger level. You should stay outside the residence in fresh air until the alarm is silenced. When the alarm sounds, do not stand too close to the alarm. The sound produced by the alarm is loud because it is designed to awaken a person in an emergency. Prolonged exposure to the alarm at a close distance may be harmful to your hearing.

NOTE: Manufacturer strongly recommends replacement of alarm six years after date of purchase. Under no circumstances should the alarm be used (7) years after the date of purchase.

3.0 DEVELOPING YOUR OWN CO SAFETY PLAN

This CO alarm can quickly alert you to the presence of CO, it cannot prevent toxic CO emissions. Please note that there are hazards against which CO detection may not be effective, such as gas leaks or explosions. The ultimate responsibility for protection against toxic CO fumes rests solely on you.

Installing CO detectors is just the first step in protecting your family from toxic CO poisoning. We also suggest that you create an effective, comprehensive safety program as outlined below.

- **3.1** Install CO detectors properly following the instructions in this manual.
- **3.2** Develop a family escape plan and practice it with your entire family, especially small children.

- ✓ Draw a floor plan of your home and find two ways to exit from each room. There should be one way to get out of each bedroom without opening the door.
- ✓ Make sure that all occupants know what the CO alarm signal means and how they must exit the residence by themselves if necessary.
- ✓ Decide on a meeting place a safe distance from your house and make sure all occupants understand where they should go and wait if there is a dangerous CO condition.
- ✓ Conduct CO safety drills at least every 6 months to make sure that everyone, even small children, know what to do in order to escape safely.
- ✓ Know where to go to call the Fire Department from outside your residence.

NOTE: This unit is designed to detect carbon monoxide (CO) entering its sensing chamber. It does not sense combustible gas (such as natural gas, propane or butane), heat, smoke or flames.

4.0 IMPORTANT: WHAT YOUR CO ALARM CAN AND CANNOT DO

- **4.1** This CO alarm is designed for use within a single residential living unit only. In a multi-family building, the alarm may not provide early warning for residents if it is placed outside of the residential units, such as on outside porches, in corridors, lobbies, basements, or in other apartments. In multi-family buildings, each residential unit should have detectors installed as previously indicated.
- **4.2** When properly located, installed, and maintained, this CO alarm is designed to provide early warning of developing poisonous CO conditions at a reasonable cost. This alarm monitors the air, and when it senses CO, it activates its built-in alarm. It can provide precious time for you and your family to escape from your residence before CO can seriously injure or kill. However, such an early warning is possible only if the alarm is located, installed, and maintained as specified in the Owner's Manual.
- ★ **WARNING:** The 2GIG-CO1-345 CO Alarm is not designed for marine, aircraft, automobile or RV use.

5.0 INSTALLING THE 2GIG-CO1-345 FOR RESIDENTIAL USE
 If bedroom doors are usually closed at night, alarms should be placed in each bedroom as well as in the common hallway between them. CO alarms may not sense CO on a different level of a residence or building. For example, a second floor alarm may not sense a CO leak on the first floor or in the basement.

Therefore, alarms should be placed on every level of a residence or building. If the alarm is located outside of a bedroom, it may not wake up a sound sleeper, especially if the bedroom door is closed or only partly open. If the alarm is located on a different level of the residence than the bedrooms, it is even less likely to wake up people sleeping in the bedroom.

Installing CO alarms may qualify you for lower homeowner's insurance rates, but CO alarms are not a substitute for insurance. Homeowners and renters should continue to insure their lives and property.

- **5.1 RECOMMENDATIONS** One of the most important considerations in any CO alarm system is the location of the alarms. Statistics of the National Fire Protection Association (NFPA) show that most of the fatal CO occurrences happen at night while people are sleeping. Early warning of CO is best achieved by the correct installation of CO alarms. Placement of an alarm in a garage may cause an alarm due to CO from automotive exhaust.
- **5.2 RECOMMENDED MOUNTING LOCATIONS** Put a CO alarm inside each bedroom where the occupant closes the door while sleeping. A closed door can block particulate smoke, but CO gas is likely to get through.
- **5.3** This CO alarm must be mounted on the wall or ceiling.

- **5.4 LOCATIONS TO AVOID** Placing units where they will not operate properly causes nuisance alarms. To avoid nuisance alarms, do not place units:
 - ✓ Within 5 feet (1.5m) of any cooking appliance or furnace.
 - ✓ Near an open window or door, because the fresh air entering the opening may delay CO from reaching the alarm.
 - ✓ In damp or very humid areas or next to bathrooms with showers or tubs. Install detectors at least 10 feet (3 meters) away from bathrooms.
 - ✓ In very cold or very hot environments or in unheated buildings or outdoor rooms where the temperature can go below or above the operating range of the alarm. Temperature limits for proper operation are 32° F to 100° F (4.4° C to 37.8° C).
 - ✓ Good ventilation is recommended when household cleaning supplies or similar contaminants are used.
- **5.5 SOME CONDITIONS WHICH CAN RESULT IN TEMPORARY CO SITUATIONS:**

- **5.5.1** Excessive spillage or reverse venting of fuel burning appliances caused by outdoor ambient conditions, such as:
 - a. Wind direction and/or velocity, including high gusts of wind. Heavy air in the vent pipes (cold/humid air with extended periods between cycles).
 - b. Negative pressure differential resulting from the use of exhaust fans.
 - c. Simultaneous operation of several fuel burning appliances competing for limited internal air.
 - d. Vent pipe connections vibrating loose from clothes dryers, furnaces, or water heaters.
 - e. Obstructions in or unconventional vent pipe designs which can amplify the above situations.
- **5.5.2** Extended operation of unvented fuel burning devices (range, oven, fireplace, etc.)
- **5.5.3** Temperature inversions, which can trap exhaust gasses near the ground.
- **5.5.4** Car idling in an open or closed area garage, or near a home.

This device complies with FCC Rules Part 15. Operation is subject to the following two conditions: (1) This device may not cause harmful interference, and (2) This device must accept any interference received, including interference that may cause undesired operation

LIMITED WARRANTY

This 2GIG Technologies product is warranted against defects in material and workmanship for two (2) years. **This warranty extends only to wholesale customers** who buy direct from 2GIG Technologies or through 2GIG Technologies' normal distribution channels. **2GIG Technologies does not warrant this product to consumers.** Consumers should inquire from their selling dealer as to the nature of the dealer's warranty, if any. **There are no obligations or liabilities on the part of 2GIG Technologies for consequential damages arising out of or in connection with use or performance of this product or other indirect damages with respect to loss of property, revenue, or profit, or cost of removal, installation, or reinstallation.** All implied warranties, including implied warranties for merchantability and implied warranties for fitness, are valid only until warranty expires. **This 2GIG Technologies Warranty is in lieu of all other warranties express or implied.**

All products returned for warranty service require a Return Product Authorization Number (RPA#). Contact 2GIG Technologies at 1-866-670-1591 for an RPA# and other important details.

For additional warranty and compliance information, visit our Web site at: www.2gig.com

IMPORTANT!!!

Radio controls provide a reliable communications link and fill an important need in portable wireless signaling. However, there are some limitations which must be observed.

- ★ For U.S. installations only: The radios are required to comply with FCC Rules and Regulations as Part 15 devices. As such, they have limited transmitter power and therefore limited range.
- ★ A receiver cannot respond to more than one transmitted signal at a time and may be blocked by radio signals that occur on or near their operating frequencies, regardless of code settings.
- ★ Changes or modifications to the device may void FCC compliance.
- ★ Infrequently used radio links should be tested regularly to protect against undetected interference or fault.
- ★ A general knowledge of radio and its vagaries should be gained prior to acting as a wholesale distributor or dealer, and these facts should be communicated to the ultimate users.