

# ENGINEERING TEST REPORT

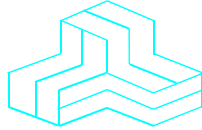

**UHF Bi-Directional Amplifier**

**Model: UBDA3845**

**FCC ID: WDM-UBDA3845**

*Applicant:*

**Comprod Communications Ltd**

*3405 North Benzing Road*

*Orchard Park, NY 14127*

*USA*

***Tested in Accordance With***

**Federal Communications Commission (FCC)**

**47 CFR, Parts 2 & 90**

**UltraTech's File No.: CMPR-007F90**

This Test report is Issued under the Authority of  
Tri M. Luu  
Vice President of Engineering  
UltraTech Group of Labs

Date: August 16, 2012

Report Prepared by: Dan Huynh

Tested by: Mr. Wei Wu

Issued Date: August 16, 2012

Test Dates: June 16 ~ August 24, 2011

- *The results in this Test Report apply only to the sample(s) tested, and the sample tested is randomly selected.*
- *This report must not be used by the client to claim product endorsement by NVLAP or any agency of the US Government.*

## UltraTech

3000 Bristol Circle, Oakville, Ontario, Canada, L6H 6G4

Tel.: (905) 829-1570 Fax.: (905) 829-8050

Website: [www.ultratech-labs.com](http://www.ultratech-labs.com), Email: [vic@ultratech-labs.com](mailto:vic@ultratech-labs.com), Email: [tri@ultratech-labs.com](mailto:tri@ultratech-labs.com)

FCC

91038



1309



46390-2049



NvLap Lab Code 200093-0



SL2-IN-E-1119R



Korea KCC-RRL  
CA2049

TABLE OF CONTENTS

**EXHIBIT 1. INTRODUCTION..... 1**

1.1. SCOPE..... 1

1.2. RELATED SUBMITTAL(S)/GRANT(S) ..... 1

1.3. NORMATIVE REFERENCES ..... 1

**EXHIBIT 2. PERFORMANCE ASSESSMENT ..... 2**

2.1. CLIENT INFORMATION ..... 2

2.2. EQUIPMENT UNDER TEST (EUT) INFORMATION ..... 2

2.3. EUT'S TECHNICAL SPECIFICATIONS ..... 3

2.4. LIST OF EUT'S PORTS ..... 3

2.5. ASSOCIATED EQUIPMENT ..... 4

2.6. ANCILLARY EQUIPMENT ..... 4

2.7. DRAWING OF TEST SETUP ..... 4

**EXHIBIT 3. EUT OPERATING CONDITIONS AND CONFIGURATIONS DURING TESTS..... 5**

3.1. CLIMATE TEST CONDITIONS ..... 5

3.2. OPERATIONAL TEST CONDITIONS & ARRANGEMENT FOR TEST SIGNALS ..... 5

**EXHIBIT 4. SUMMARY OF TEST RESULTS ..... 6**

4.1. LOCATION OF TESTS ..... 6

4.2. APPLICABILITY & SUMMARY OF EMC EMISSION TEST RESULTS ..... 6

4.3. MODIFICATIONS INCORPORATED IN THE EUT FOR COMPLIANCE PURPOSES ..... 6

4.4. DEVIATION OF STANDARD TEST PROCEDURES ..... 6

**EXHIBIT 5. TEST DATA ..... 7**

5.1. POWER LINE CONDUCTED EMISSIONS [[§ 15.107(b)] ..... 7

5.2. RF POWER OUTPUT [§§ 2.1046, 90.205 & 90.219] ..... 10

5.3. OCCUPIED BANDWIDTH [§ 2.1049] ..... 12

5.4. SPURIOUS EMISSIONS AT ANTENNA TERMINAL AND INTERMODULATION [§§ 2.1051, 2.1057 & 90.210] ..... 19

5.5. FIELD STRENGTH OF SPURIOUS RADIATION [§§ 90.210, 2.1053 & 2.1057] ..... 45

5.6. RF EXPOSURE REQUIRMENTS [§§ 1.1310 & 2.1091] ..... 47

**EXHIBIT 6. TEST EQUIPMENT LIST ..... 49**

**EXHIBIT 7. MEASUREMENT UNCERTAINTY ..... 50**

7.1. LINE CONDUCTED EMISSION MEASUREMENT UNCERTAINTY ..... 50

7.2. RADIATED EMISSION MEASUREMENT UNCERTAINTY ..... 50

## EXHIBIT 1. INTRODUCTION

### 1.1. SCOPE

<b>Reference:</b>	FCC Part 2 & 90
<b>Title:</b>	Telecommunication - Code of Federal Regulations, CFR 47, Part 2 & 90
<b>Purpose of Test:</b>	To gain FCC Certification Authorization for Radio Amplifier operating in the Frequency Range 380 - 445 MHz
<b>Test Procedures:</b>	Both conducted and radiated emissions measurements were conducted in accordance with American National Standards Institute ANSI C63.4 - American National Standard for Methods of Measurement of Radio-Noise Emissions from Low-Voltage Electrical and Electronic Equipment in the Range of 9 kHz to 40 GHz.

### 1.2. RELATED SUBMITTAL(S)/GRANT(S)

None.

### 1.3. NORMATIVE REFERENCES

Publication	Year	Title
FCC CFR Parts 0-19, 80-End	2011	Code of Federal Regulations – Title 47, Telecommunication
ANSI C63.4	2009	American National Standard for Methods of Measurement of Radio-Noise Emissions from Low-Voltage Electrical and Electronic Equipment in the Range of 9 kHz to 40 GHz
CISPR 16-1-1 +A1 +A2	2006 2006 2007	Specification for radio disturbance and immunity measuring apparatus and methods. Part 1-1: Measuring Apparatus
TIA/EIA 603, Edition C	2004	Land Mobile FM or PM Communications Equipment Measurement and Performance Standards

---

#### ULTRATECH GROUP OF LABS

3000 Bristol Circle, Oakville, Ontario, Canada L6H 6G4  
Tel. #: 905-829-1570, Fax. #: 905-829-8050, Email: [vic@ultratech-labs.com](mailto:vic@ultratech-labs.com), Website: <http://www.ultratech-labs.com>

File #: CMPR-007F90  
August 16, 2012

All test results contained in this engineering test report are traceable to National Institute of Standards and Technology (NIST)

## EXHIBIT 2. PERFORMANCE ASSESSMENT

### 2.1. CLIENT INFORMATION

APPLICANT	
<b>Name:</b>	Comprod Communications Ltd
<b>Address:</b>	3405 North Benzing Road Orchard Park, NY 14127 USA
<b>Contact Person:</b>	Mr. Fernando Apolinario Phone #: 450-641-1454 Fax #: 450-641-4616 Email Address: fapolinario@comprodcom.com

MANUFACTURER	
<b>Name:</b>	Comprod Communications Ltd
<b>Address:</b>	138 De La Barre Boucherville, Quebec Canada 4127
<b>Contact Person:</b>	Mr. Fernando Apolinario Phone #: 450-641-1454 Fax #: 450-641-4616 Email Address: fapolinario@comprodcom.com

### 2.2. EQUIPMENT UNDER TEST (EUT) INFORMATION

The following information (with the exception of the Date of Receipt) has been supplied by the applicant.

<b>Brand Name:</b>	Comprod Communications Ltd
<b>Product Name:</b>	UHF Bi-Directional Amplifier
<b>Model Name or Number:</b>	UBDA3845
<b>Serial Number:</b>	Test Sample
<b>Type of Equipment:</b>	Booster
<b>Power Supply Requirement:</b>	100-260 VAC 50 / 60 Hz
<b>Transmitting/Receiving Antenna Type:</b>	Non-Integral
<b>Primary User Functions of EUT:</b>	Extends RF coverage area of radio communications indoor/outdoor environments.

#### ULTRATECH GROUP OF LABS

3000 Bristol Circle, Oakville, Ontario, Canada L6H 6G4  
Tel. #: 905-829-1570, Fax. #: 905-829-8050, Email: [vic@ultratech-labs.com](mailto:vic@ultratech-labs.com), Website: <http://www.ultratech-labs.com>

File #: CMPR-007F90  
August 16, 2012

All test results contained in this engineering test report are traceable to National Institute of Standards and Technology (NIST)

**2.3. EUT'S TECHNICAL SPECIFICATIONS**

<b>Transmitter</b>	
<b>Equipment Type:</b>	Base station (fixed use)
<b>Intended Operating Environment:</b>	Commercial, Light Industry & Heavy Industry
<b>RF Output Power Rating (Conducted):</b>	Single output: 32.5 dBm or 1.778 Watts
<b>Operating Frequency Range:</b>	Uplink band: 380 - 445 MHz Downlink band: 380 - 445 MHz
<b>RF Input/Output Impedance:</b>	50 Ohm
<b>Nominal Gain (at -40dBm input power):</b>	76 dB maximum
<b>Occupied Bandwidth (99%):</b>	Booster
<b>Emission Designation:</b>	F3E, F1D
<b>Antenna Connector Type:</b>	SMA
<b>Antenna Description:</b>	Antenna gain: 3.5 dBd maximum
<b>Receiver</b>	
<b>Equipment Type:</b>	Base station (fixed use)
<b>Intended Operating Environment:</b>	Commercial, Light Industry & Heavy Industry
<b>Power Supply Requirement:</b>	100-260 VAC 50 / 60 Hz
<b>RF Input Power Rating:</b>	Single input: -40 dBm nominal
<b>Operating Frequency Range:</b>	Uplink band: 380 - 445 MHz Downlink band: 380 - 445 MHz

**2.4. LIST OF EUT'S PORTS**

<b>Port Number</b>	<b>EUT's Port Description</b>	<b>Number of Identical Ports</b>	<b>Connector Type</b>	<b>Cable Type (Shielded/Non-shielded)</b>
1	AC power input	1	RCPT waterproof 3 positions, male	Non-shielded
2	D/L VGA IN	1	SMA female	Shielded
3	D/L VGA OUT	1	SMA female	Shielded
4	D/L PA IN	1	SMA female	Shielded
5	D/L PA OUT	1	SMA female	Shielded
6	U/L VGA IN	1	SMA female	Shielded
7	U/L VGA OUT	1	SMA female	Shielded
8	U/L PA IN	1	SMA female	Shielded
9	U/L PA OUT	1	SMA female	Shielded

**ULTRATECH GROUP OF LABS**

3000 Bristol Circle, Oakville, Ontario, Canada L6H 6G4  
 Tel. #: 905-829-1570, Fax. #: 905-829-8050, Email: [vic@ultratech-labs.com](mailto:vic@ultratech-labs.com), Website: <http://www.ultratech-labs.com>

File #: CPMR-007F90  
 August 16, 2012

*All test results contained in this engineering test report are traceable to National Institute of Standards and Technology (NIST)*

**2.5. ASSOCIATED EQUIPMENT**

None.

**2.6. ANCILLARY EQUIPMENT**

N/A

**2.7. DRAWING OF TEST SETUP**

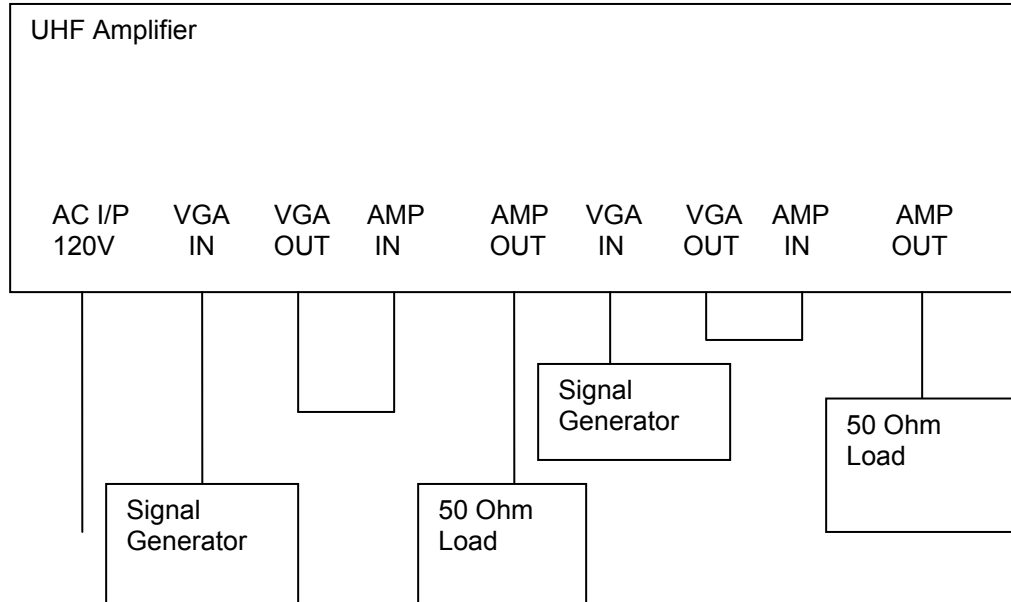

**EXHIBIT 3. EUT OPERATING CONDITIONS AND CONFIGURATIONS DURING TESTS**

**3.1. CLIMATE TEST CONDITIONS**

The climate conditions of the test environment are as follows:

Temperature:	22°C
Humidity:	54%
Pressure:	100 kPa
Power input source:	120 VAC, 60 Hz

**3.2. OPERATIONAL TEST CONDITIONS & ARRANGEMENT FOR TEST SIGNALS**

<b>Operating Modes:</b>	The amplifier was operated in a continuous transmission mode with the carrier modulated as specified in the Test Data.
<b>Special Test Software:</b>	N/A
<b>Special Hardware Used:</b>	N/A
<b>Transmitter Test Antenna:</b>	The EUT is tested with the amplifier antenna ports terminated to a 50 Ohm RF Load.

<b>Transmitter Test Signals</b>	
<b>Frequency Band(s):</b>	380 - 445 MHz
<b>Frequency(ies) Tested:</b> (Near lowest, near middle & near highest frequencies in the frequency range of operation.)	406.2, 429.9 and 444.0 MHz
<b>Transmitter Wanted Output Test Signals:</b>	
Transmitter Power (measured maximum output power):	32.76 dBm
Normal Test Modulation:	F3E, F1D
Modulating signal source:	External

## EXHIBIT 4. SUMMARY OF TEST RESULTS

### 4.1. LOCATION OF TESTS

All of the measurements described in this report were performed at Ultratech Group of Labs located in the city of Oakville, Province of Ontario, Canada.

- AC Power Line Conducted Emissions were performed in UltraTech's shielded room, 24'(L) by 16'(W) by 8'(H).
- Radiated Emissions were performed at the Ultratech's 3-10 TDK Semi-Anechoic Chamber situated in the Town of Oakville, province of Ontario. This test site been calibrated in accordance with ANSI C63.4, and found to be in compliance with the requirements of Sec. 2.948 of the FCC Rules. The descriptions and site measurement data of the Oakville 3-10 TDK Semi-Anechoic Chamber has been filed with FCC office (FCC File No.: 91038) and Industry Canada office (Industry Canada File No.: 2049A-3). Expiry Date: 2014-04-04.

### 4.2. APPLICABILITY & SUMMARY OF EMC EMISSION TEST RESULTS

FCC Section(s)	Test Requirements	Compliance (Yes/No)
15.107(b)	AC Power Line Conducted Emissions	Yes
2.1046 & 90.219	RF Power Output & Inter-modulation	Yes
1.1307, 1.1310, 2.1091	RF Exposure Limit	Yes
2.1055 & 90.213	Frequency Stability	N/A for Amplifier
2.1047(a)	Audio Frequency Response	N/A for Amplifier
2.1047(b) & 90.210	Modulation Limiting	N/A for Amplifier
2.1049	Occupied Bandwidth	Yes
2.1051, 2.1057 & 90.210	Spurious Emissions at Antenna Terminals	Yes
2.1053, 2.1057 & 90.210	Field Strength of Spurious Radiation	Yes

### 4.3. MODIFICATIONS INCORPORATED IN THE EUT FOR COMPLIANCE PURPOSES

None.

### 4.4. DEVIATION OF STANDARD TEST PROCEDURES

None.

---

#### ULTRATECH GROUP OF LABS

3000 Bristol Circle, Oakville, Ontario, Canada L6H 6G4  
Tel. #: 905-829-1570, Fax. #: 905-829-8050, Email: [vic@ultratech-labs.com](mailto:vic@ultratech-labs.com), Website: <http://www.ultratech-labs.com>

File #: CMPR-007F90  
August 16, 2012

All test results contained in this engineering test report are traceable to National Institute of Standards and Technology (NIST)



**EXHIBIT 5. TEST DATA**

**Remark:**

The amplification chain for Downlink band and Uplink band are identical, each chain consists of an identical VGA unit and an identical Power Amplifier unit. The the following test results will represents worst-case test configuration for both Downlink and Uplink bands.

**5.1. POWER LINE CONDUCTED EMISSIONS [[§ 15.107(b)]]**

**5.1.1. Limits**

The equipment shall meet the limits of the following table:

Frequency of emission (MHz)	Conducted Limits (dBµV)	
	Quasi-peak	Average
0.15 - 0.5	79	66
0.5 - 30	73	60

**5.1.2. Method of Measurements**

Refer to Ultratech Test Procedures ULTR-P001-2004 & ANSI C63.4 for method of measurements.

**5.1.3. Test Arrangement**

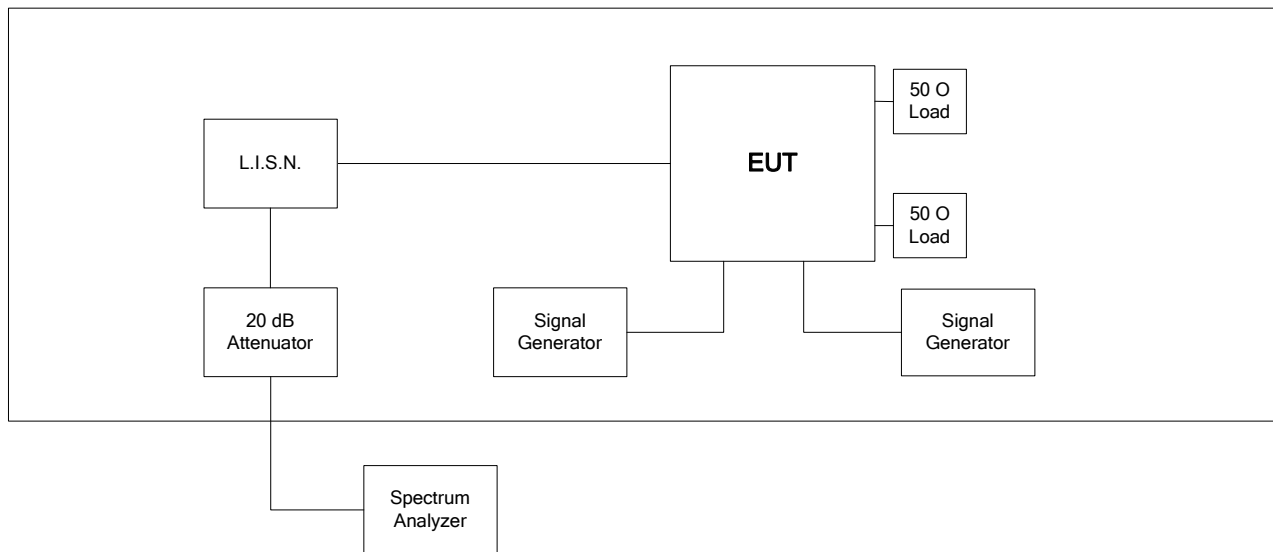

5.1.4. Test Data

Plot 5.1.4.1. Power Line Conducted Emissions  
 Line Voltage: 120 VAC 60 Hz, Line Tested: Hot

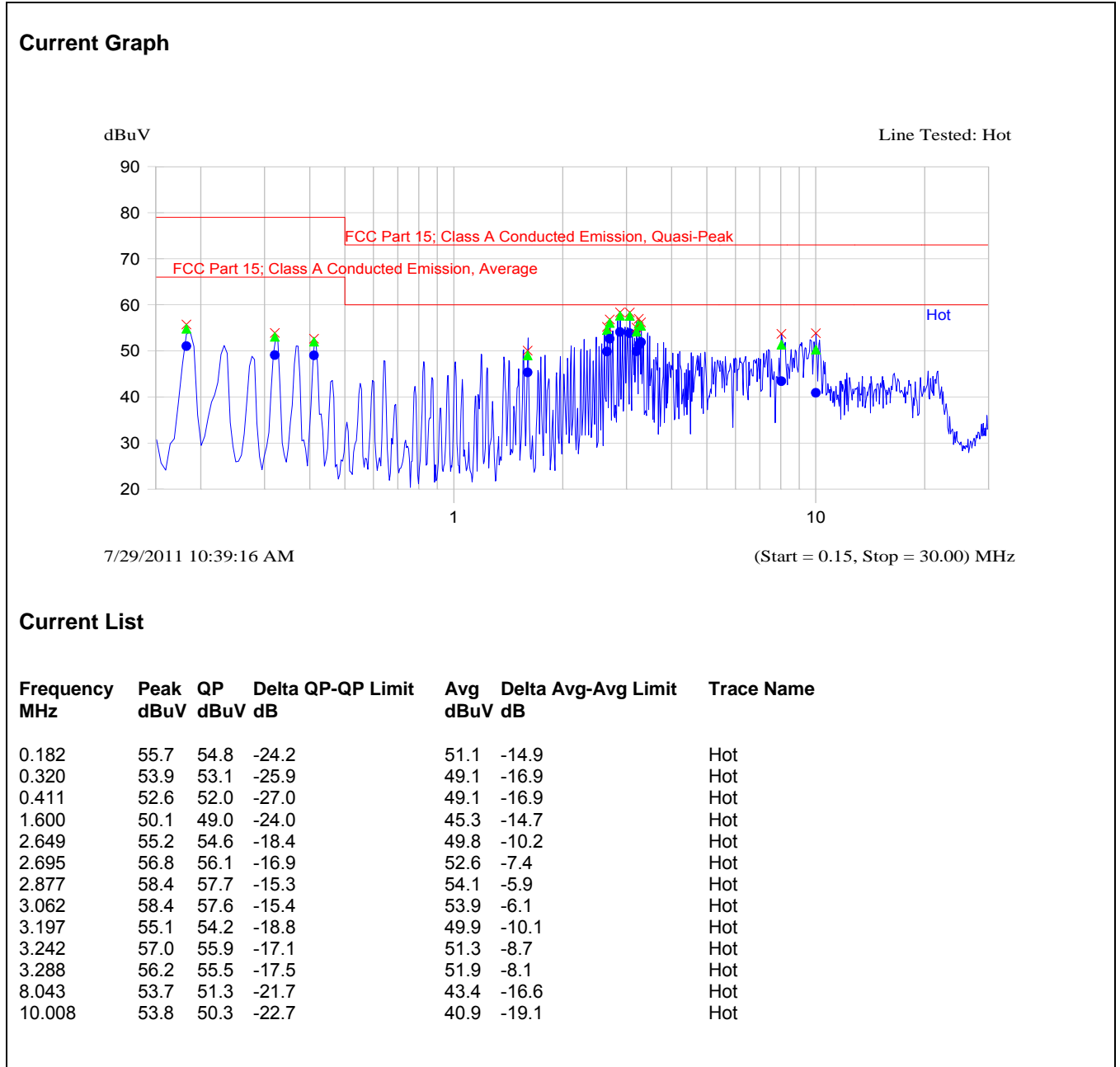

**Plot 5.1.4.2. Power Line Conducted Emissions**  
 Line Voltage: 120 VAC 60 Hz, Line Tested: Neutral

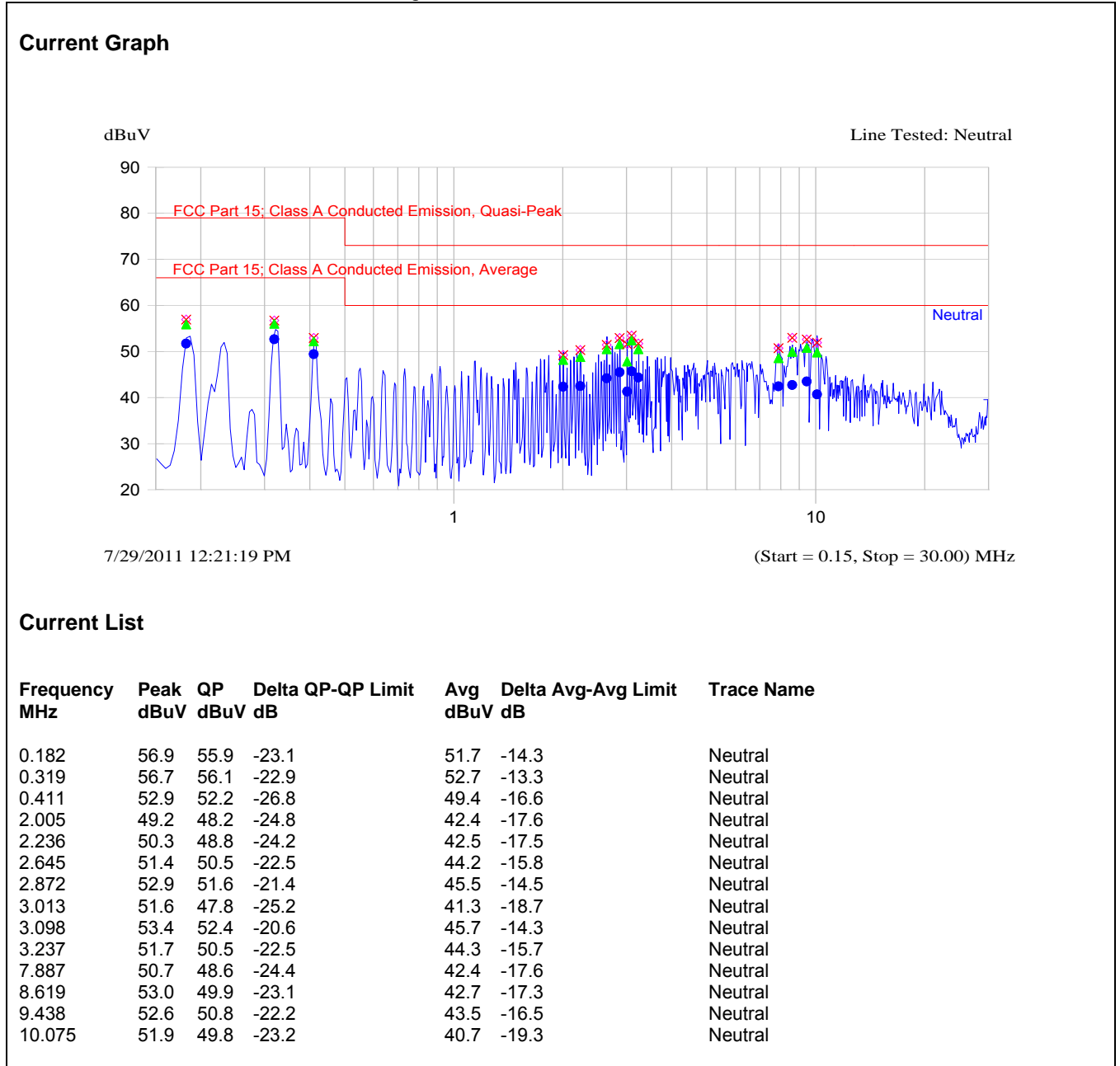

## 5.2. RF POWER OUTPUT [§§ 2.1046, 90.205 & 90.219]

### 5.2.1. Limits

FCC 47 CFR 90.205 for specification details, and § 90.219 Licensees authorized to operate radio systems in the frequency bands above 150 MHz may employ signal boosters at fixed locations in accordance with the following criteria:

(a) The amplified signal is retransmitted only on the exact frequency(ies) of the originating base, fixed, mobile, or portable station(s). The booster will fill in only weak signal areas and cannot extend the system's normal signal coverage area.

(b) Class A narrowband signal boosters must be equipped with automatic gain control circuitry which will limit the total effective radiated power (ERP) of the unit to a maximum of 5 watts under all conditions. Class B broadband signal boosters are limited to 5 watts ERP for each authorized frequency that the booster is designed to amplify.

### 5.2.2. Method of Measurements

ANSI/TIA-603-C-2004

### 5.2.3. Test Arrangement

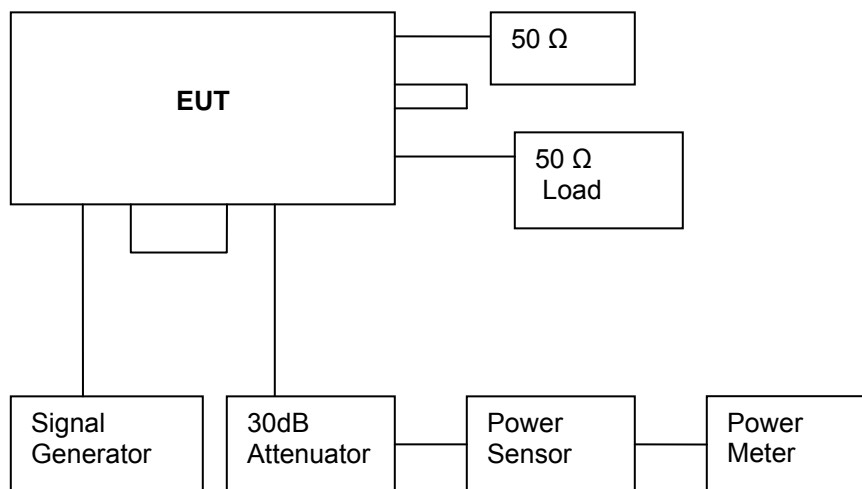

**5.2.4. Test Data**

Remark: The maximum antenna gain to be used with this device is 3.5 dBd.

Test Frequency (MHz)	Channel Spacing (kHz)	Input Power (dBm)	VGA Input Level Adjustment Setting	VGA Output Power Setting	Total RF Output Power at Antenna Port	
					(dBm)	(Watt)
406.2	6.25	-39.66	0	F	29.09	0.811
	12.5	-39.66	0	D	30.78	1.197
	25	-39.66	0	C	31.37	1.371
429.9	6.25	-39.58	0	C	28.83	0.764
	12.5	-39.58	0	8	32.76	1.888
	25	-39.56	0	8	32.76	1.888
444.0	6.25	-39.75	0	C	29.26	0.843
	12.5	-39.85	0	9	32.24	1.675
	25	-39.93	0	9	32.24	1.675

### 5.3. OCCUPIED BANDWIDTH [§ 2.1049]

#### 5.3.1. Limits

The spectral shape of the output should look similar to input for all modulations.

#### 5.3.2. Method of Measurements

The measurement procedure shall be as follows:

Step 1:

- Connect the EUT to the spectrum analyzer and use the following settings:

Span: the minimum span to fully display the emission  
Resolution BW: 300 Hz or 1% of the approximate emission width  
Video BW: 3 times the Resolution BW or greater  
Video Averaging: none  
Sweep time: coupled or set to a slower rate

Step 2:

- When the trace is complete, capture the trace.
- Find the peak value of the trace and place the analyzer marker on this peak.

Step 3:

- Use the 99 % bandwidth function of the spectrum analyzer to measure the occupied bandwidth of the EUT. This value shall be recorded.

#### 5.3.3. Test Arrangement

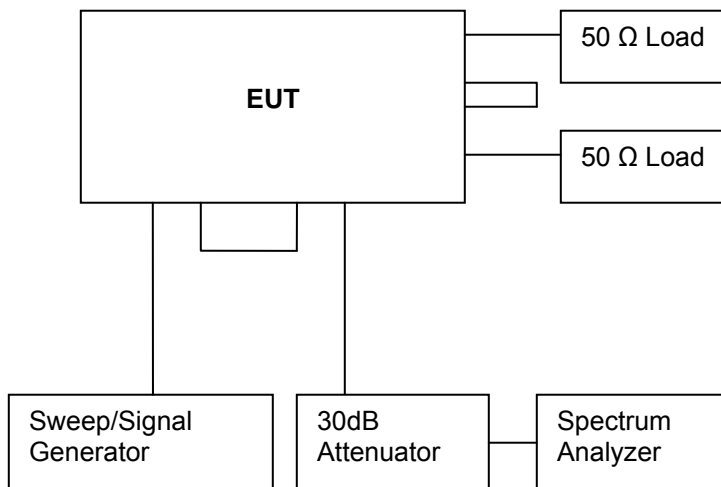

5.3.4. Test Data

Plot 5.3.4.1. 99% Occupied Bandwidth – Input Signal, F1D  
 Transmitter Frequency: 406.2 MHz

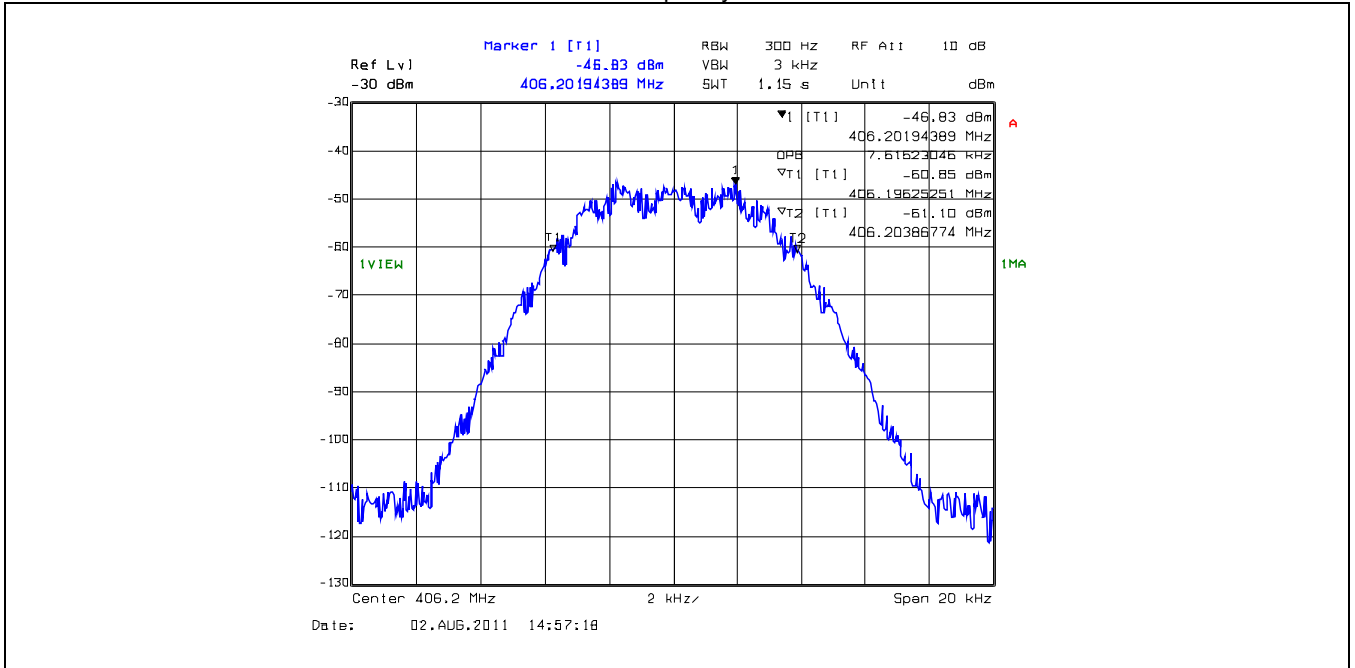

Plot 5.3.4.2. 99% Occupied Bandwidth – Output Signal, F1D  
 Transmitter Frequency: 406.2 MHz

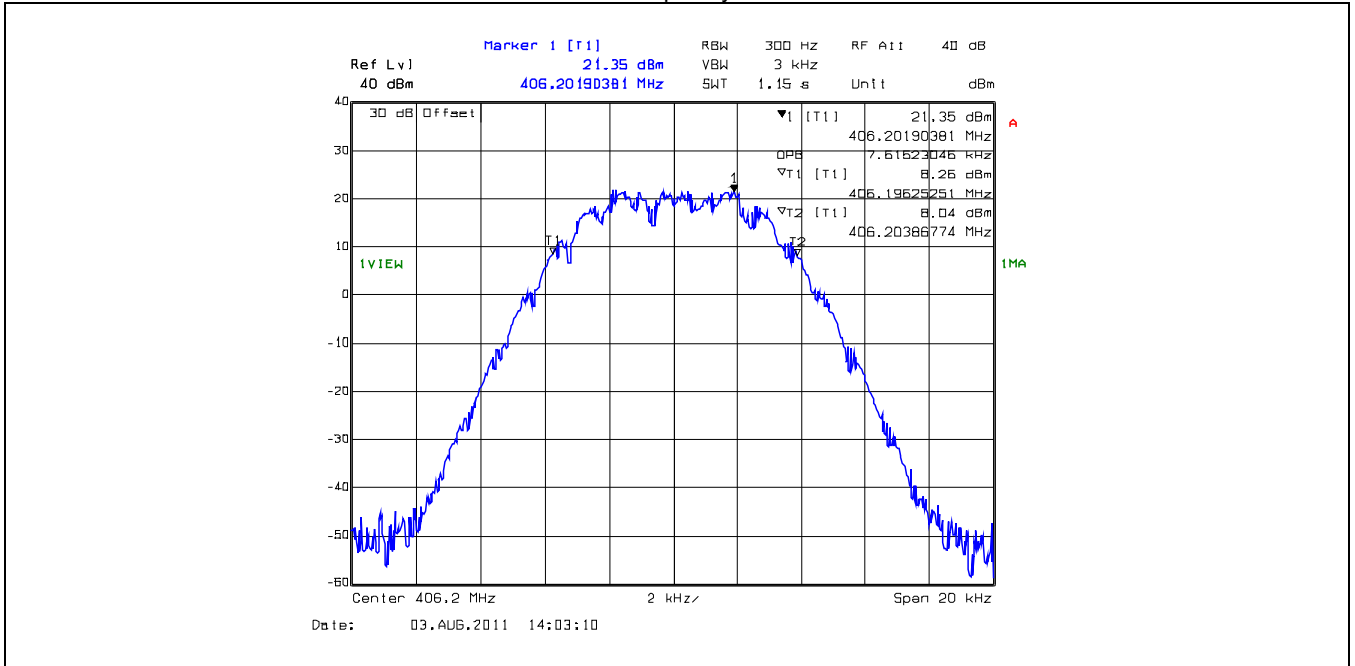

Plot 5.3.4.3. 99% Occupied Bandwidth – Input Signal, F1D  
 Transmitter Frequency: 429.9 MHz

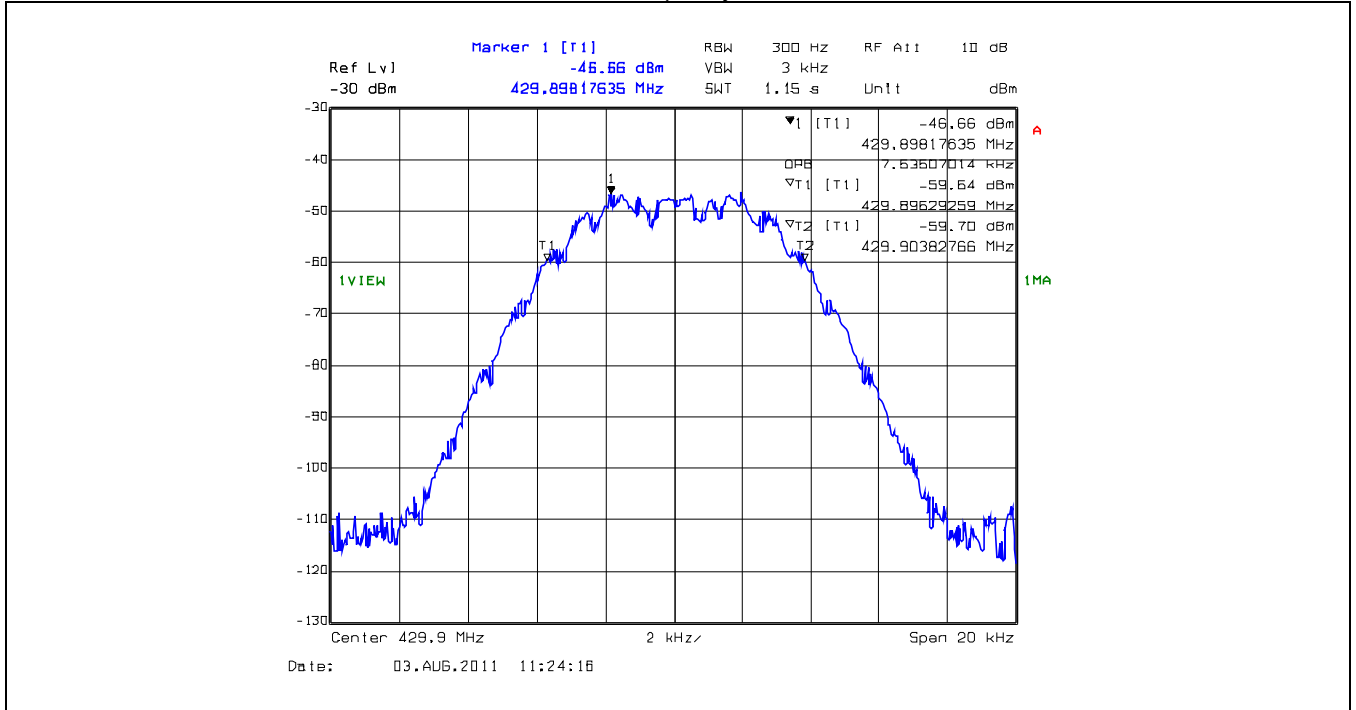

Plot 5.3.4.4. 99% Occupied Bandwidth – Output Signal, F1D  
 Transmitter Frequency: 429.9 MHz

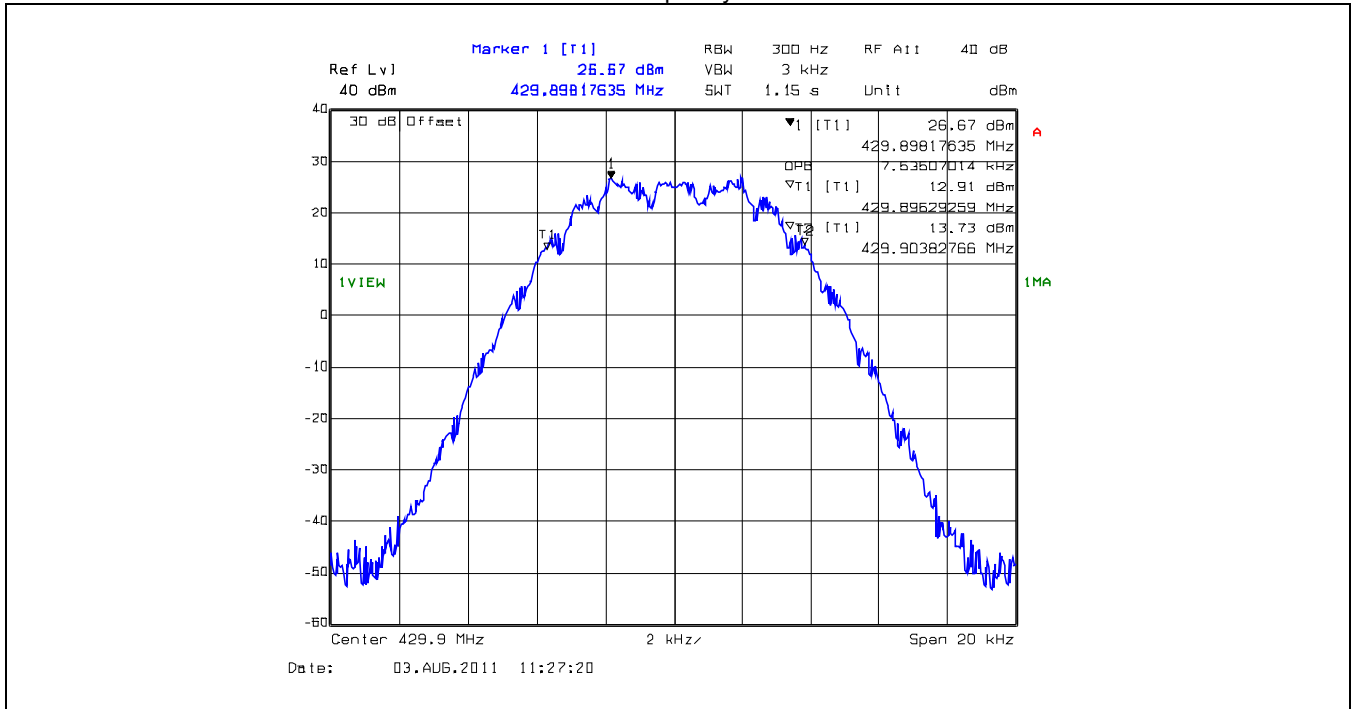

**ULTRATECH GROUP OF LABS**

3000 Bristol Circle, Oakville, Ontario, Canada L6H 6G4  
 Tel. #: 905-829-1570, Fax. #: 905-829-8050, Email: [vic@ultratech-labs.com](mailto:vic@ultratech-labs.com), Website: <http://www.ultratech-labs.com>

File #: CMPR-007F90  
 August 16, 2012

All test results contained in this engineering test report are traceable to National Institute of Standards and Technology (NIST)



**Plot 5.3.4.5. 99% Occupied Bandwidth – Input Signal, F1D**  
 Transmitter Frequency: 444.0 MHz

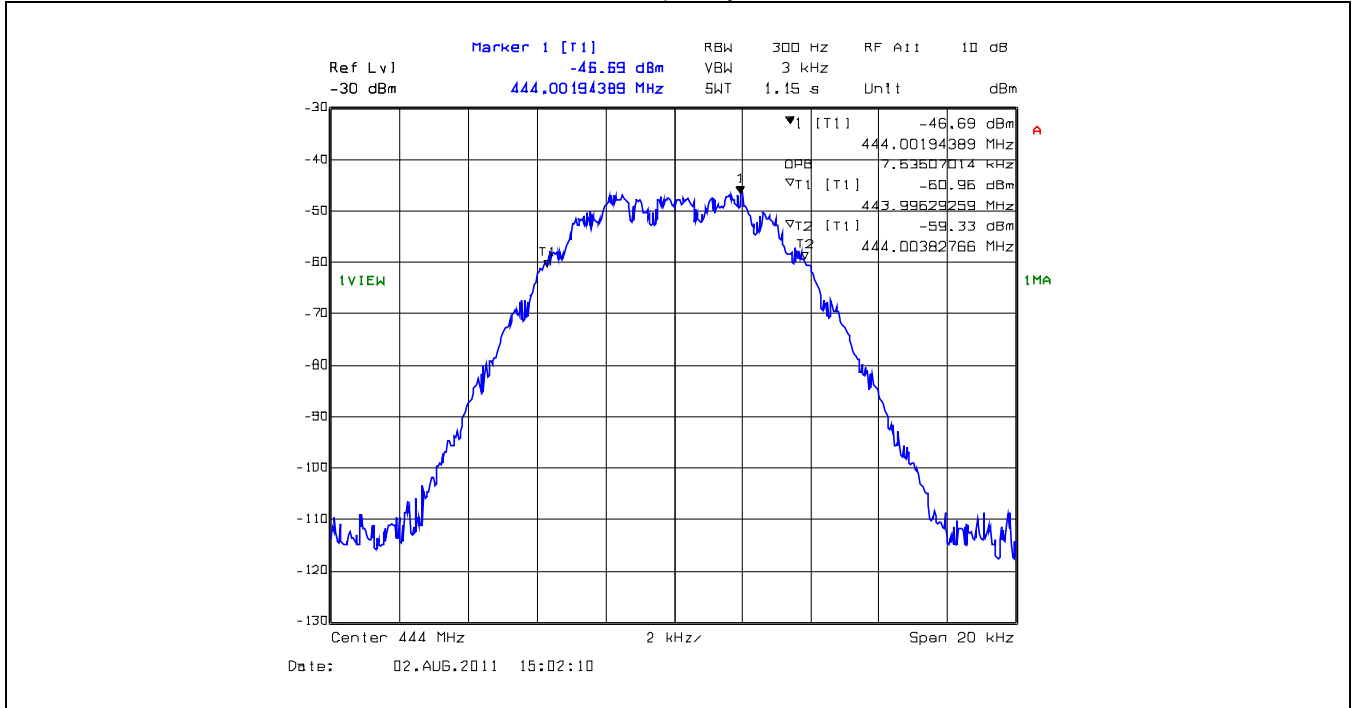

**Plot 5.3.4.6. 99% Occupied Bandwidth – Output Signal, F1D**  
 Transmitter Frequency: 444.0 MHz

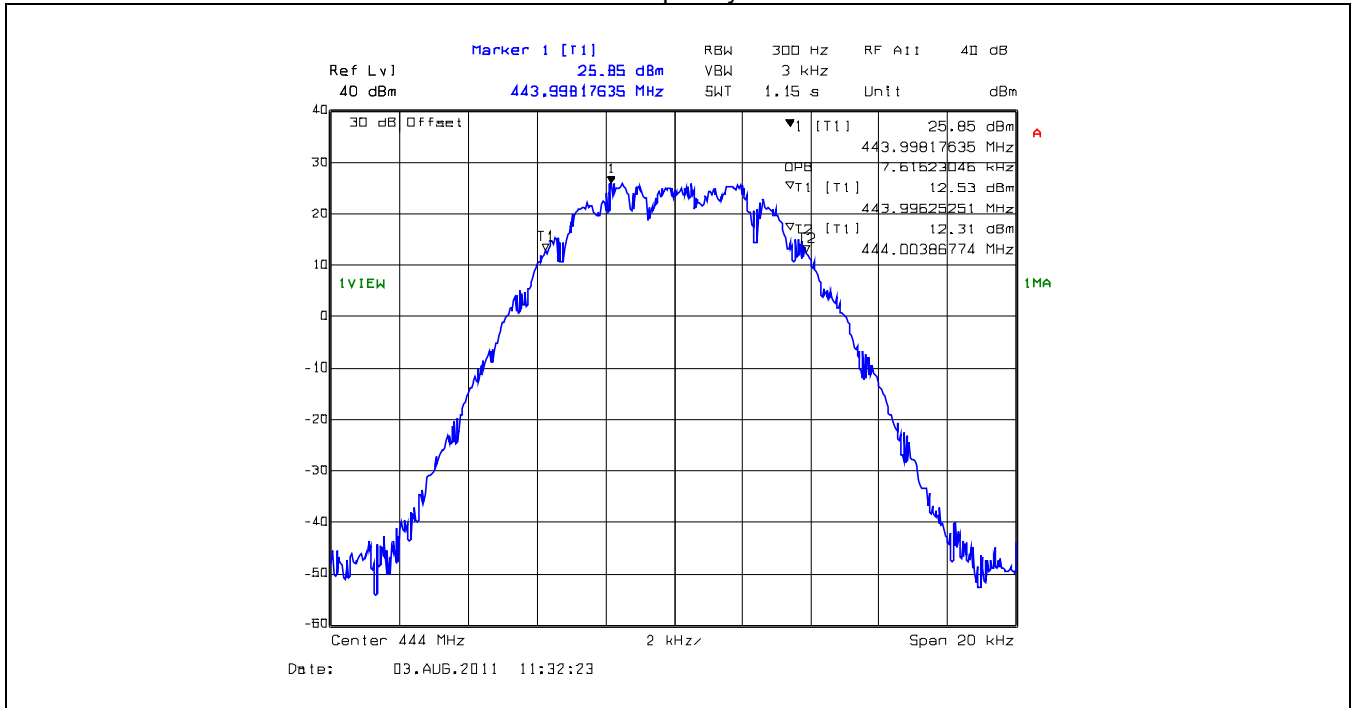

Plot 5.3.4.7. 99% Occupied Bandwidth – Input Signal, F3E  
 Transmitter Frequency: 406.2 MHz

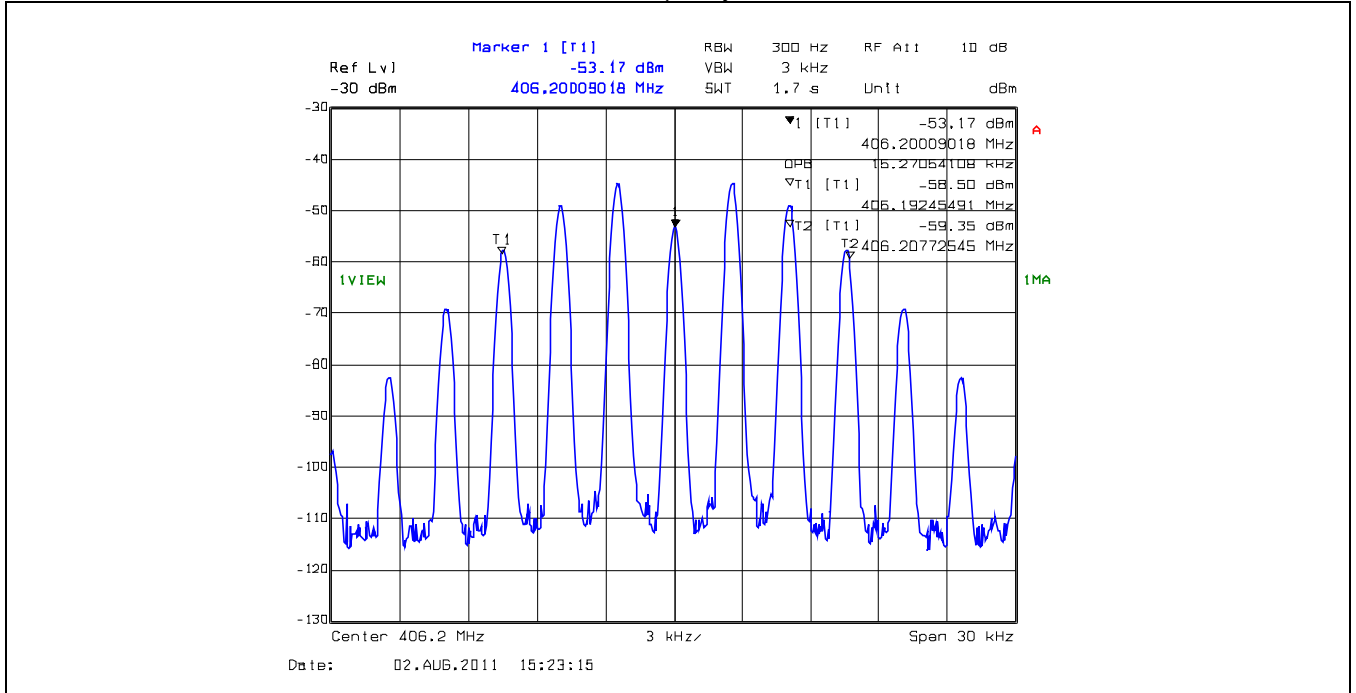

Plot 5.3.4.8. 99% Occupied Bandwidth – Output Signal, F3E  
 Transmitter Frequency: 406.2 MHz

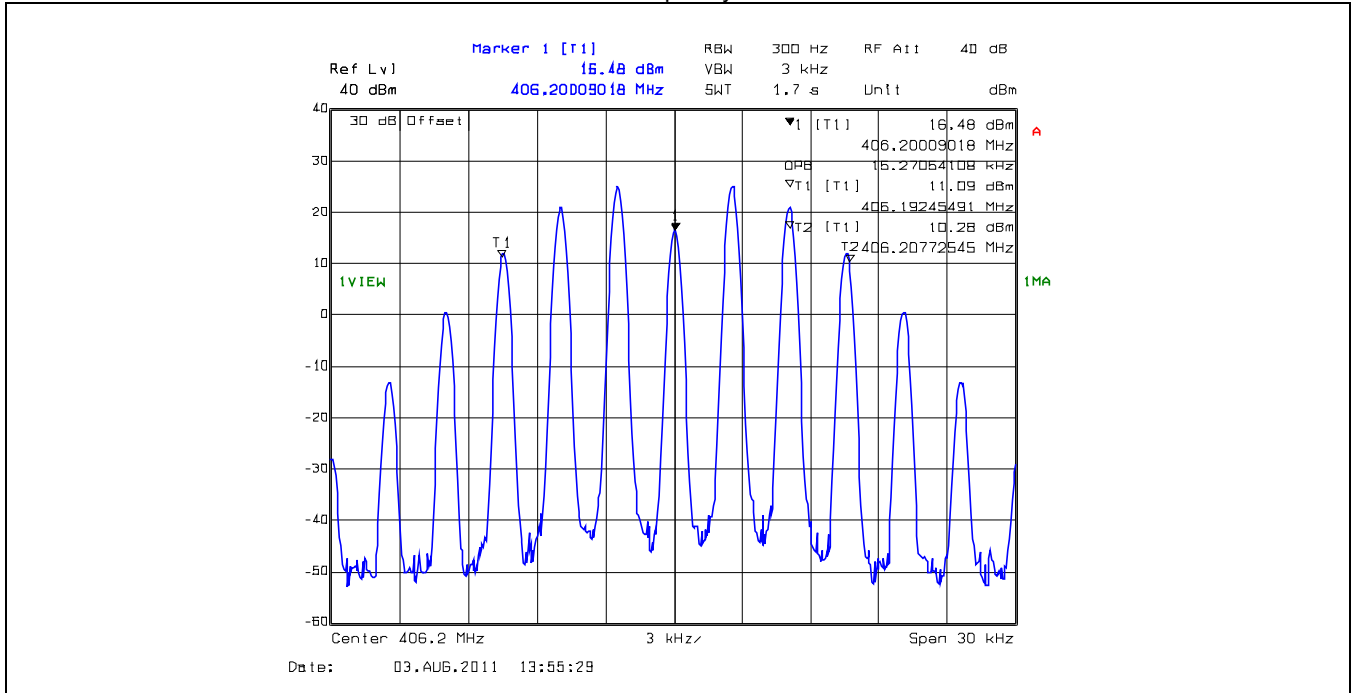

**ULTRATECH GROUP OF LABS**

3000 Bristol Circle, Oakville, Ontario, Canada L6H 6G4  
 Tel. #: 905-829-1570, Fax. #: 905-829-8050, Email: [vic@ultratech-labs.com](mailto:vic@ultratech-labs.com), Website: <http://www.ultratech-labs.com>

File #: CMPR-007F90  
 August 16, 2012

All test results contained in this engineering test report are traceable to National Institute of Standards and Technology (NIST)

**Plot 5.3.4.9. 99% Occupied Bandwidth – Input Signal, F3E**  
 Transmitter Frequency: 429.9 MHz

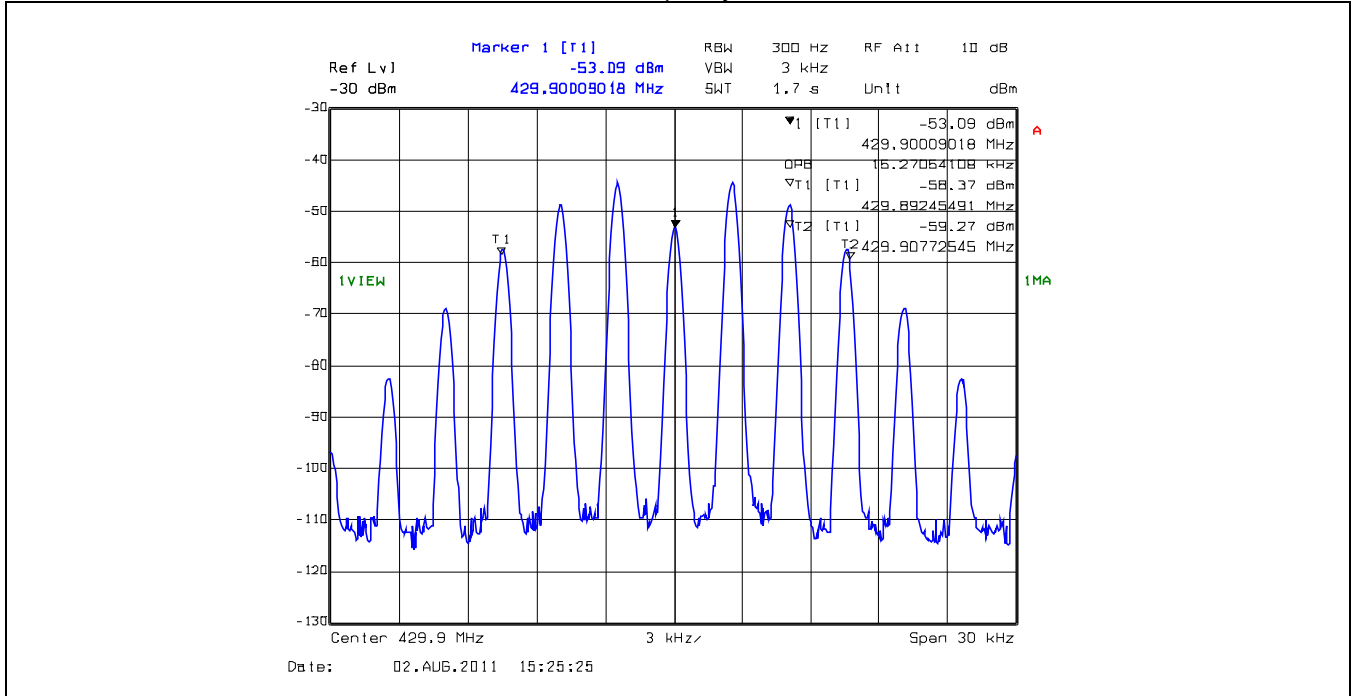

**Plot 5.3.4.10. 99% Occupied Bandwidth – Output Signal, F3E**  
 Transmitter Frequency: 429.9 MHz

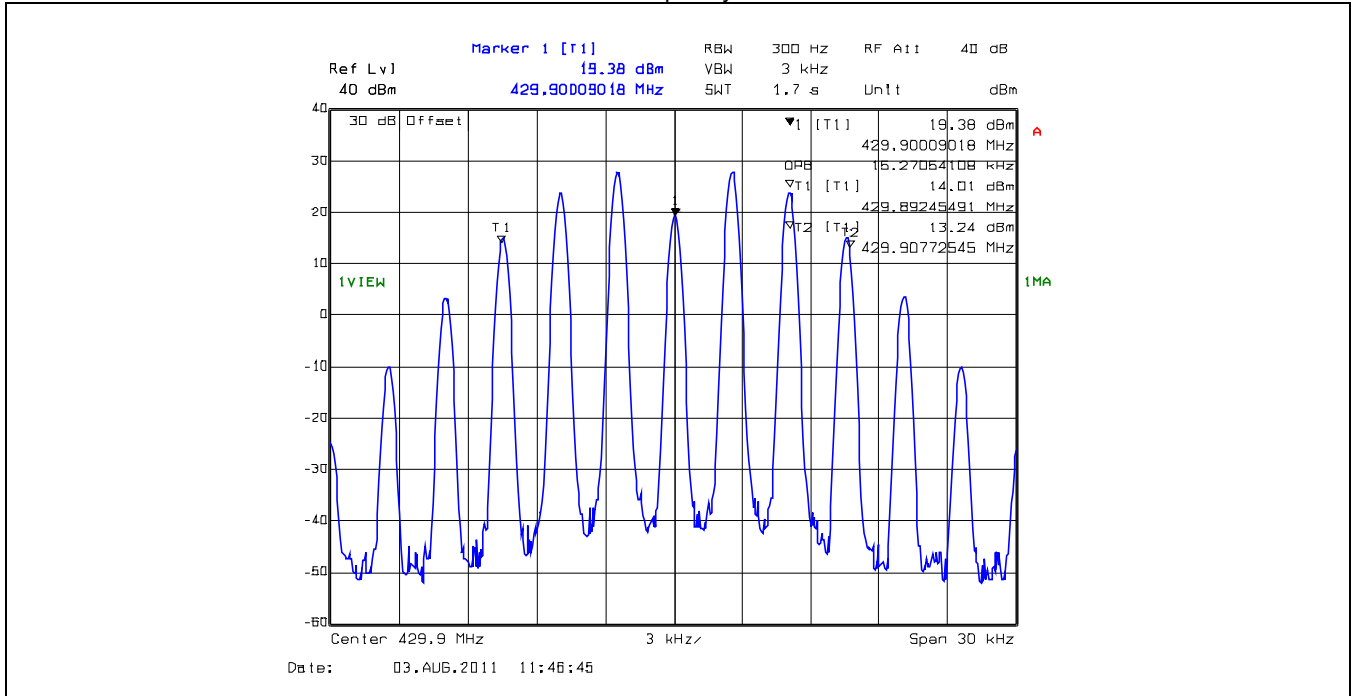

Plot 5.3.4.11. 99% Occupied Bandwidth – Input Signal, F3E  
 Transmitter Frequency: 444.0 MHz

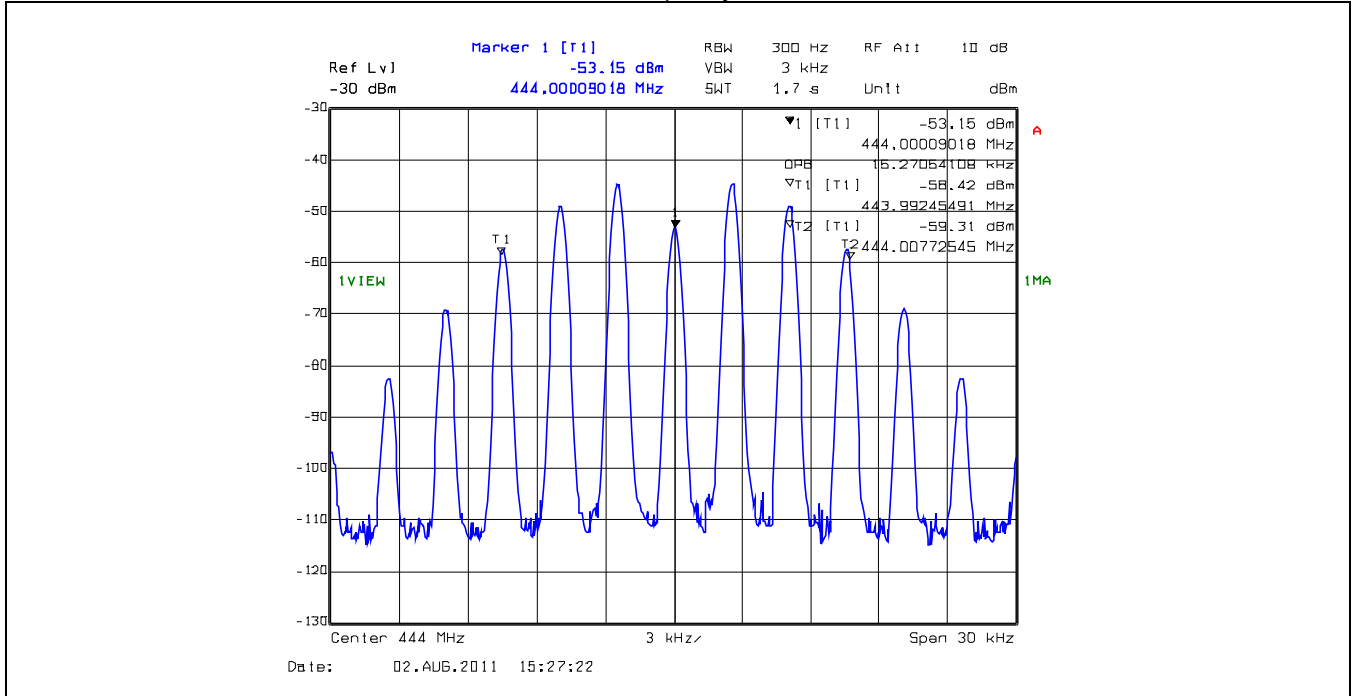

Plot 5.3.4.12. 99% Occupied Bandwidth – Output Signal, F3E  
 Transmitter Frequency: 444.0 MHz

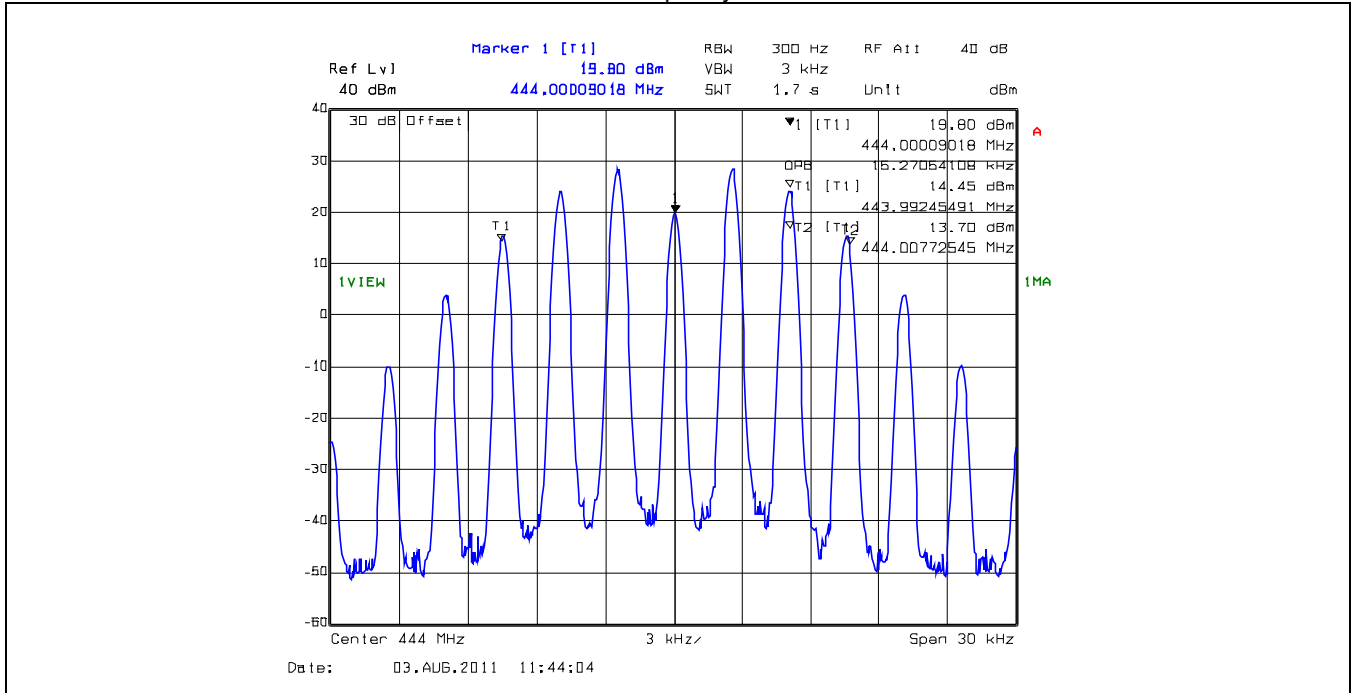

**5.4. SPURIOUS EMISSIONS AT ANTENNA TERMINAL AND INTERMODULATION [§§ 2.1051, 2.1057 & 90.210]**

**5.4.1. Limits**

§ 90.219 (c) Class A narrowband boosters must meet the out-of-band emission limits of § 90.210 for each narrowband channel that the booster is designed to amplify. Class B broadband signal boosters must meet the emission limits of § 90.210 for frequencies outside of the booster's designed passband.

KDB 935210 - FCC guidelines for testing amplifiers, boosters and repeater:  
Intermodulation limit: -13dBm conducted.

**5.4.2. Method of Measurements**

TIA-603-C.

**5.4.3. Test Arrangement**

**Single Channel Input:**

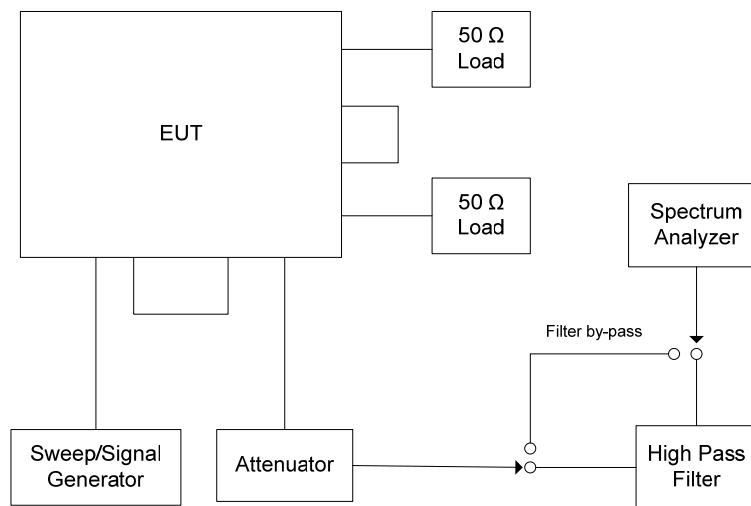

**Multiple Channel Inputs:**

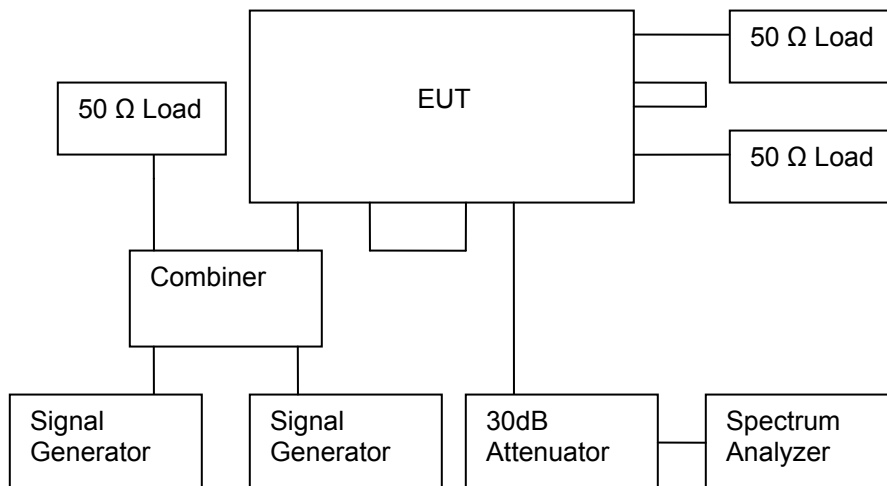

### 5.4.4. Test Data

#### Remarks:

- The RF emissions were scanned with all different modulations and there was no discernable difference in the spurious emissions between the different modulation types. Therefore, the final tests were only performed without modulation and it shall represent for all different modulations required.
- Single RF input will be tested to represent the worst case with highest input/output powers

**Plot 5.4.4.1.** Conducted Transmitter Spurious Emissions for 406.2 MHz, 25 kHz Channel Spacing, 30 - 600 MHz

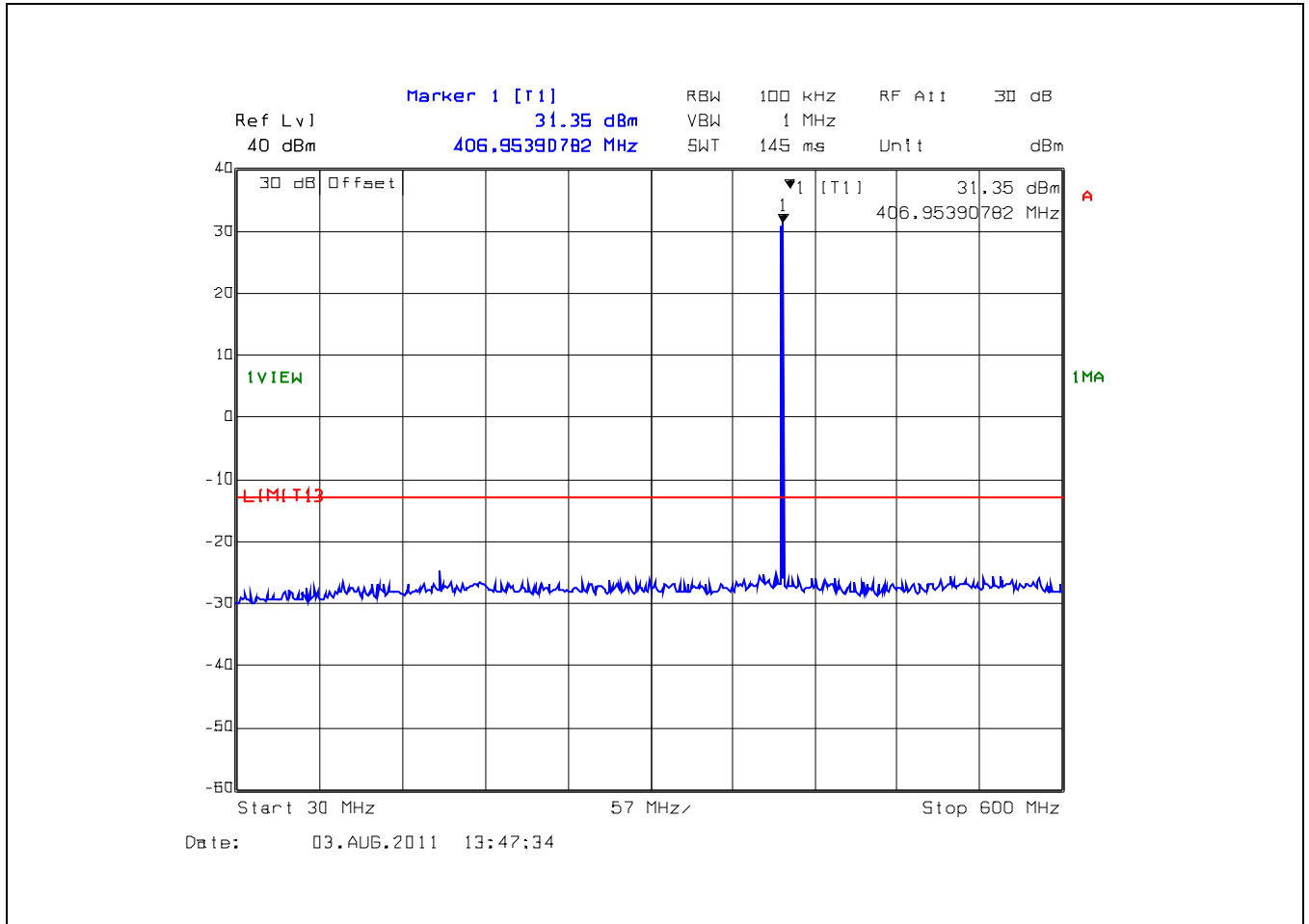

Plot 5.4.4.2. Conducted Transmitter Spurious Emissions for 406.2 MHz, 25 kHz Channel Spacing, 600 MHz - 5.5 GHz

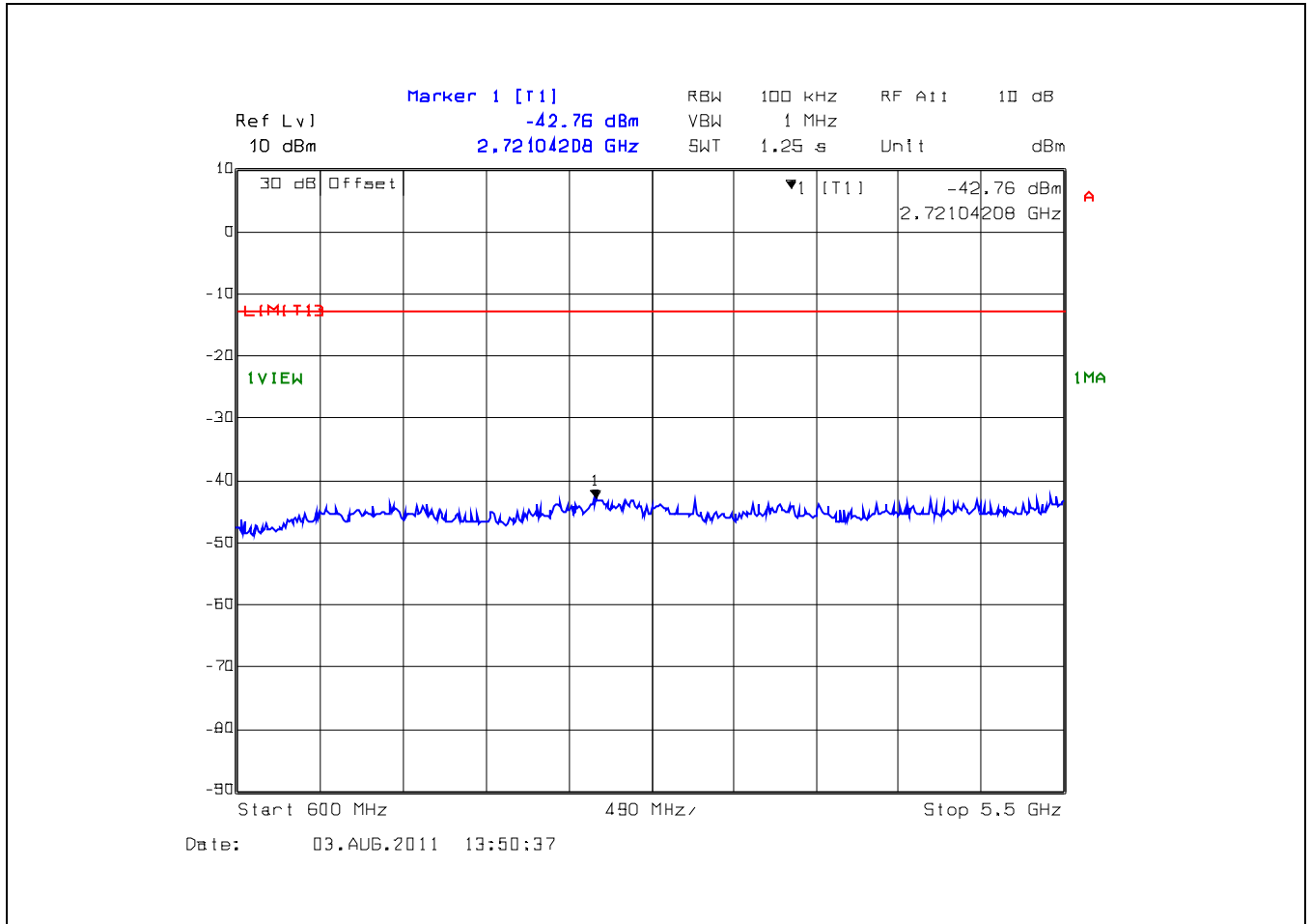

**ULTRATECH GROUP OF LABS**

3000 Bristol Circle, Oakville, Ontario, Canada L6H 6G4  
 Tel. #: 905-829-1570, Fax. #: 905-829-8050, Email: [vic@ultratech-labs.com](mailto:vic@ultratech-labs.com), Website: <http://www.ultratech-labs.com>

File #: CMPR-007F90  
 August 16, 2012

All test results contained in this engineering test report are traceable to National Institute of Standards and Technology (NIST)



Plot 5.4.4.3. Conducted Transmitter Spurious Emissions for 429.9 MHz, 25 kHz Channel Spacing, 30 - 600 MHz

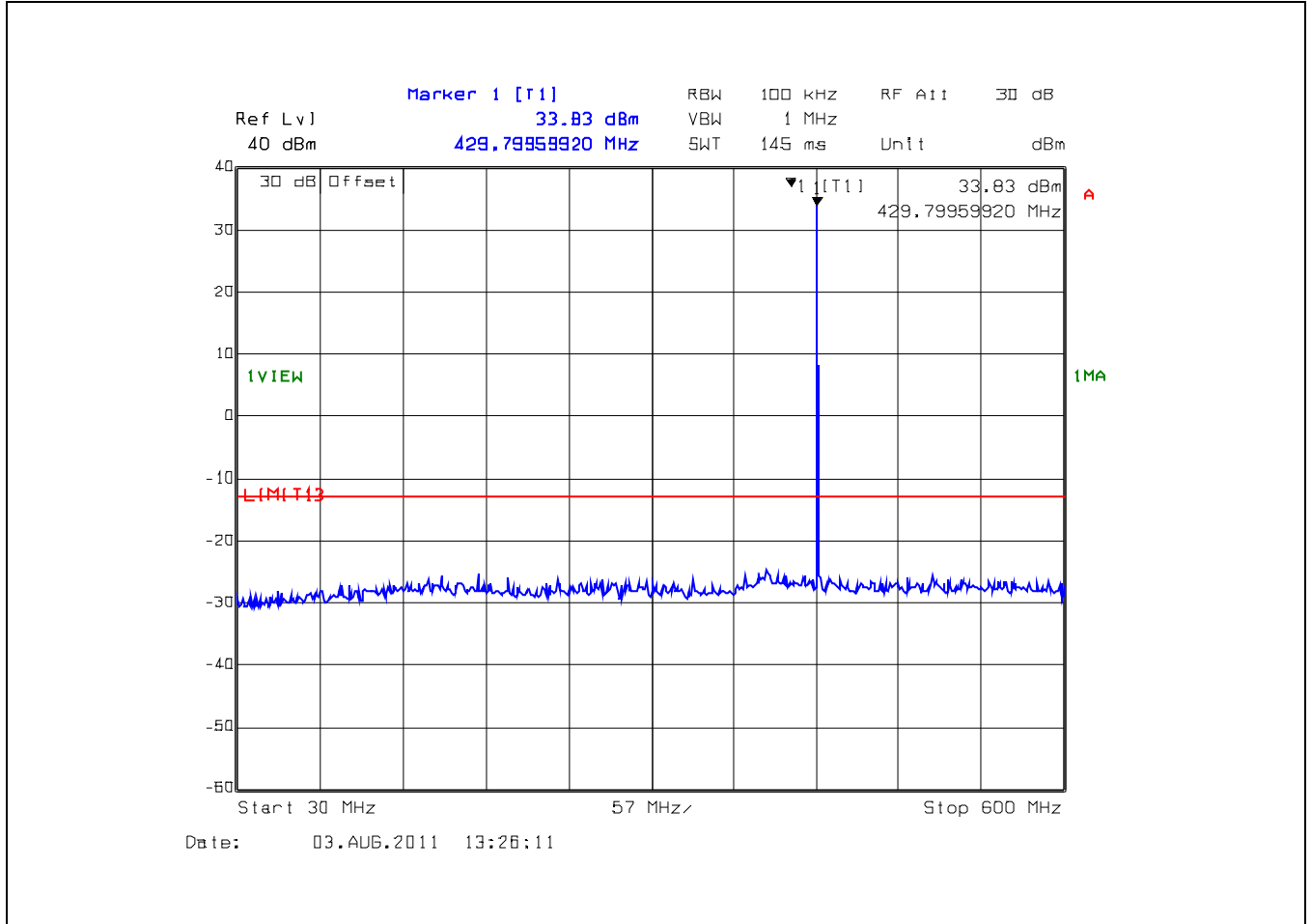

**Plot 5.4.4.4.** Conducted Transmitter Spurious Emissions for 429.9 MHz, 25 kHz Channel Spacing, 600 MHz - 5.5 GHz

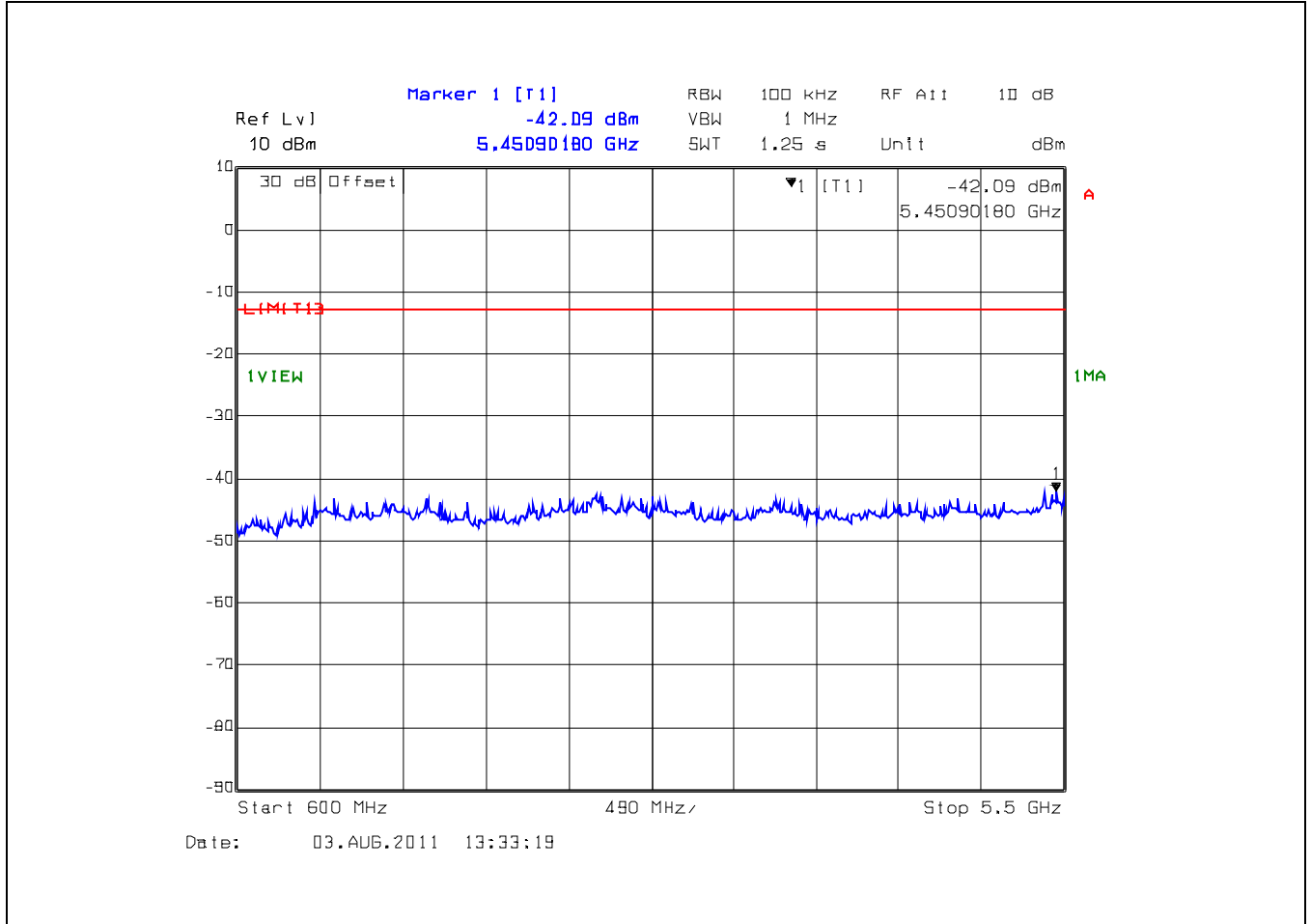

**ULTRATECH GROUP OF LABS**

3000 Bristol Circle, Oakville, Ontario, Canada L6H 6G4  
 Tel. #: 905-829-1570, Fax. #: 905-829-8050, Email: [vic@ultratech-labs.com](mailto:vic@ultratech-labs.com), Website: <http://www.ultratech-labs.com>

File #: CMPR-007F90  
 August 16, 2012

All test results contained in this engineering test report are traceable to National Institute of Standards and Technology (NIST)

Plot 5.4.4.5. Conducted Transmitter Spurious Emissions for 444.0 MHz, 25 kHz Channel Spacing, 30 - 600 MHz

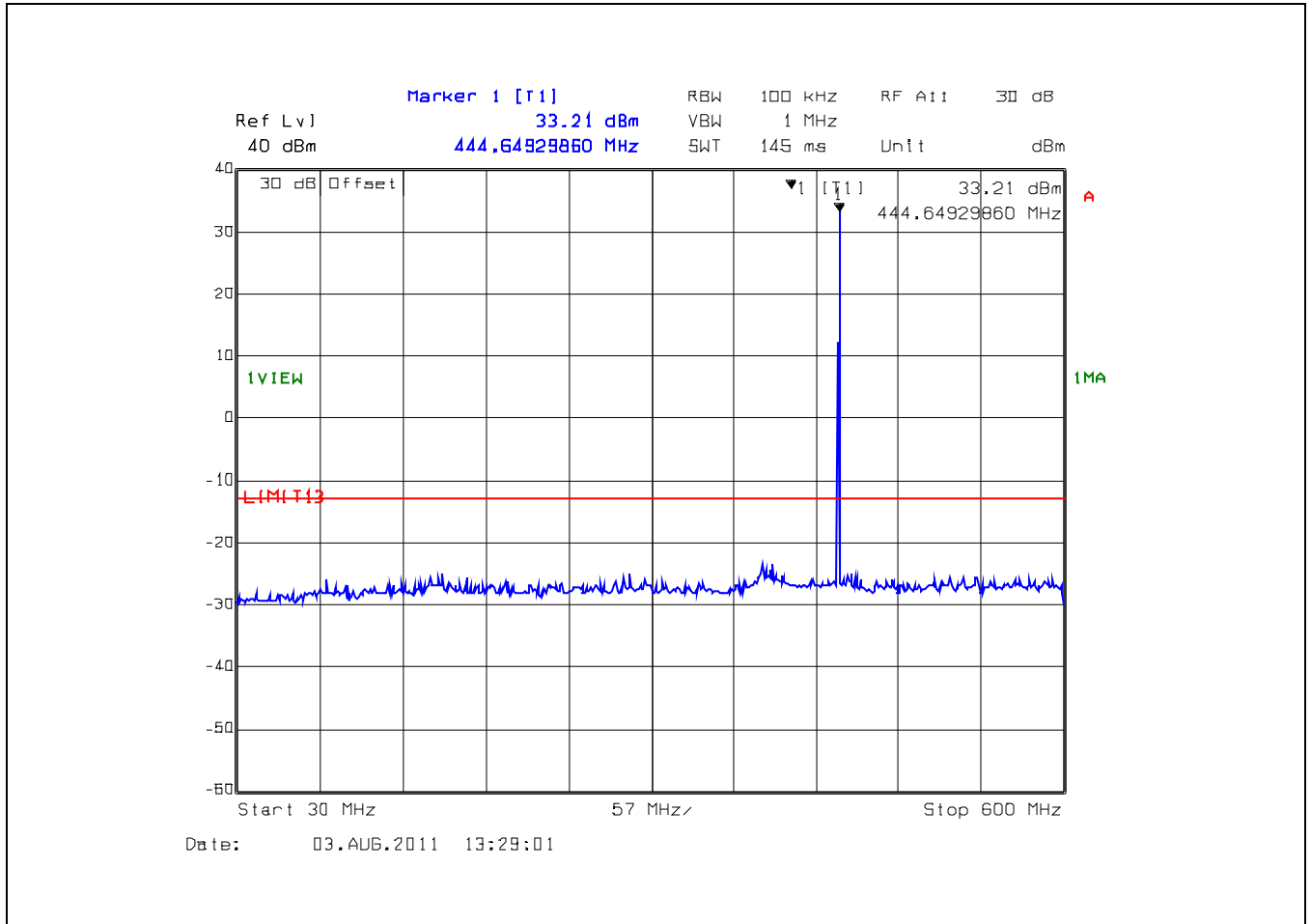

**ULTRATECH GROUP OF LABS**

3000 Bristol Circle, Oakville, Ontario, Canada L6H 6G4  
Tel. #: 905-829-1570, Fax. #: 905-829-8050, Email: [vic@ultratech-labs.com](mailto:vic@ultratech-labs.com), Website: <http://www.ultratech-labs.com>

File #: CMPR-007F90  
August 16, 2012

All test results contained in this engineering test report are traceable to National Institute of Standards and Technology (NIST)

Plot 5.4.4.6. Conducted Transmitter Spurious Emissions for 444.0 MHz, 25 kHz Channel Spacing, 600 MHz - 5.5 GHz

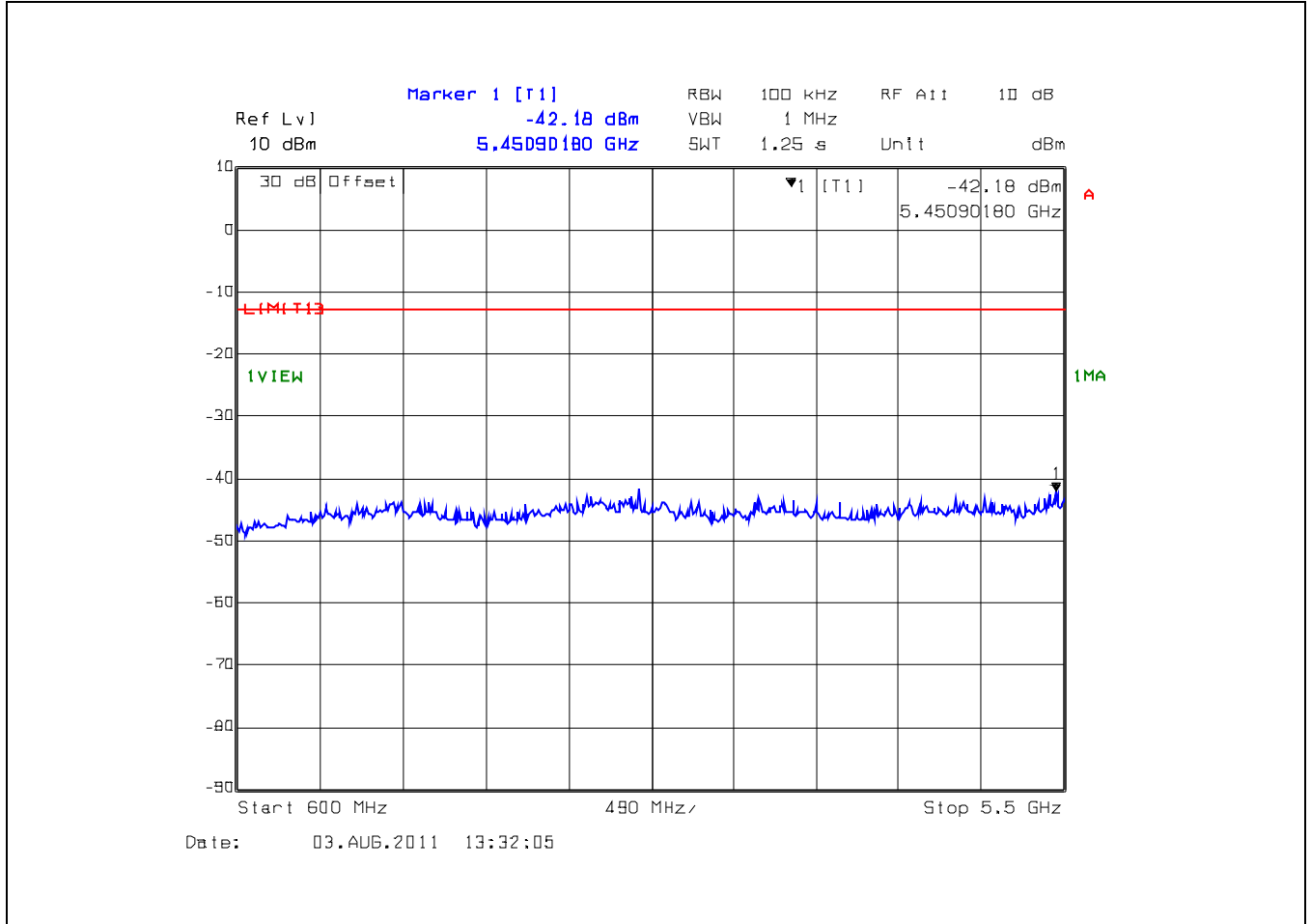

**ULTRATECH GROUP OF LABS**

3000 Bristol Circle, Oakville, Ontario, Canada L6H 6G4  
Tel. #: 905-829-1570, Fax. #: 905-829-8050, Email: [vic@ultratech-labs.com](mailto:vic@ultratech-labs.com), Website: <http://www.ultratech-labs.com>

File #: CMPR-007F90  
August 16, 2012

All test results contained in this engineering test report are traceable to National Institute of Standards and Technology (NIST)

Plot 5.4.4.7. Conducted Transmitter Spurious Emissions for 406.2 MHz, 12.5 kHz Channel Spacing, 30 - 600 MHz

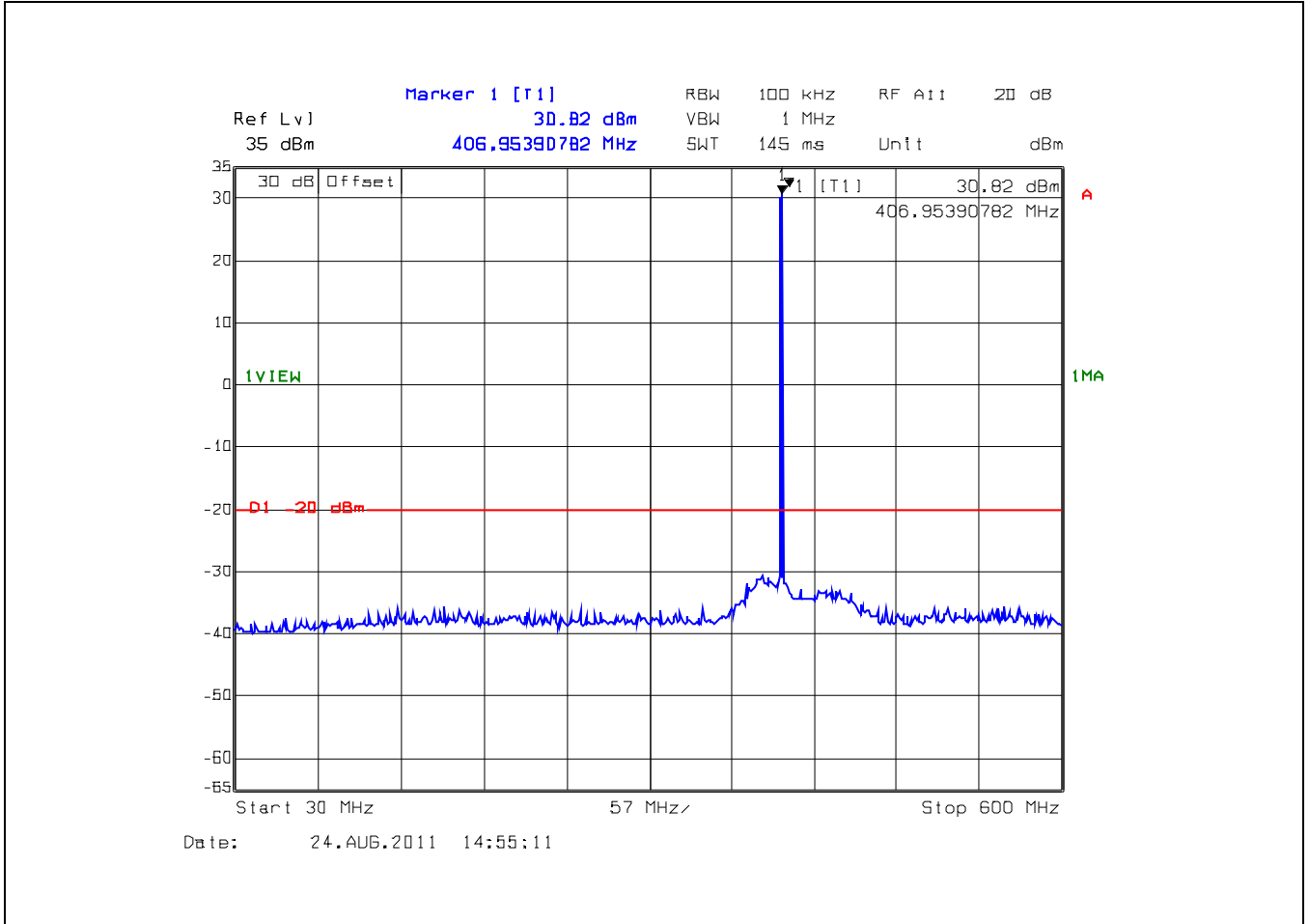

**ULTRATECH GROUP OF LABS**

3000 Bristol Circle, Oakville, Ontario, Canada L6H 6G4  
Tel. #: 905-829-1570, Fax. #: 905-829-8050, Email: [vic@ultratech-labs.com](mailto:vic@ultratech-labs.com), Website: <http://www.ultratech-labs.com>

File #: CMPR-007F90  
August 16, 2012

All test results contained in this engineering test report are traceable to National Institute of Standards and Technology (NIST)

Plot 5.4.4.8. Conducted Transmitter Spurious Emissions for 406.2 MHz, 12.5 kHz Channel Spacing, 600 MHz - 5.5 GHz

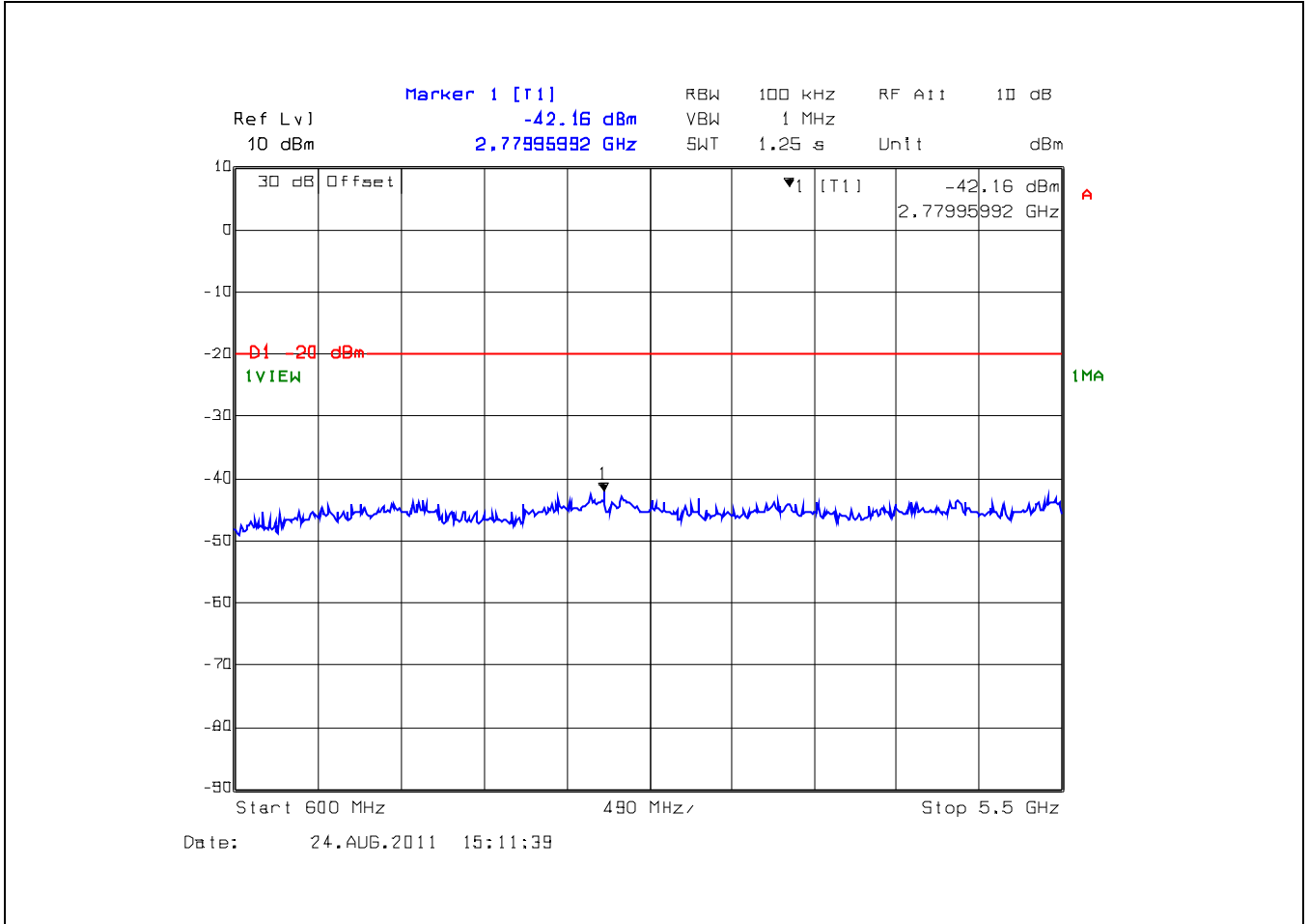



Plot 5.4.4.10. Conducted Transmitter Spurious Emissions for 429.9 MHz, 12.5 kHz Channel Spacing, 600 MHz - 5.5 GHz

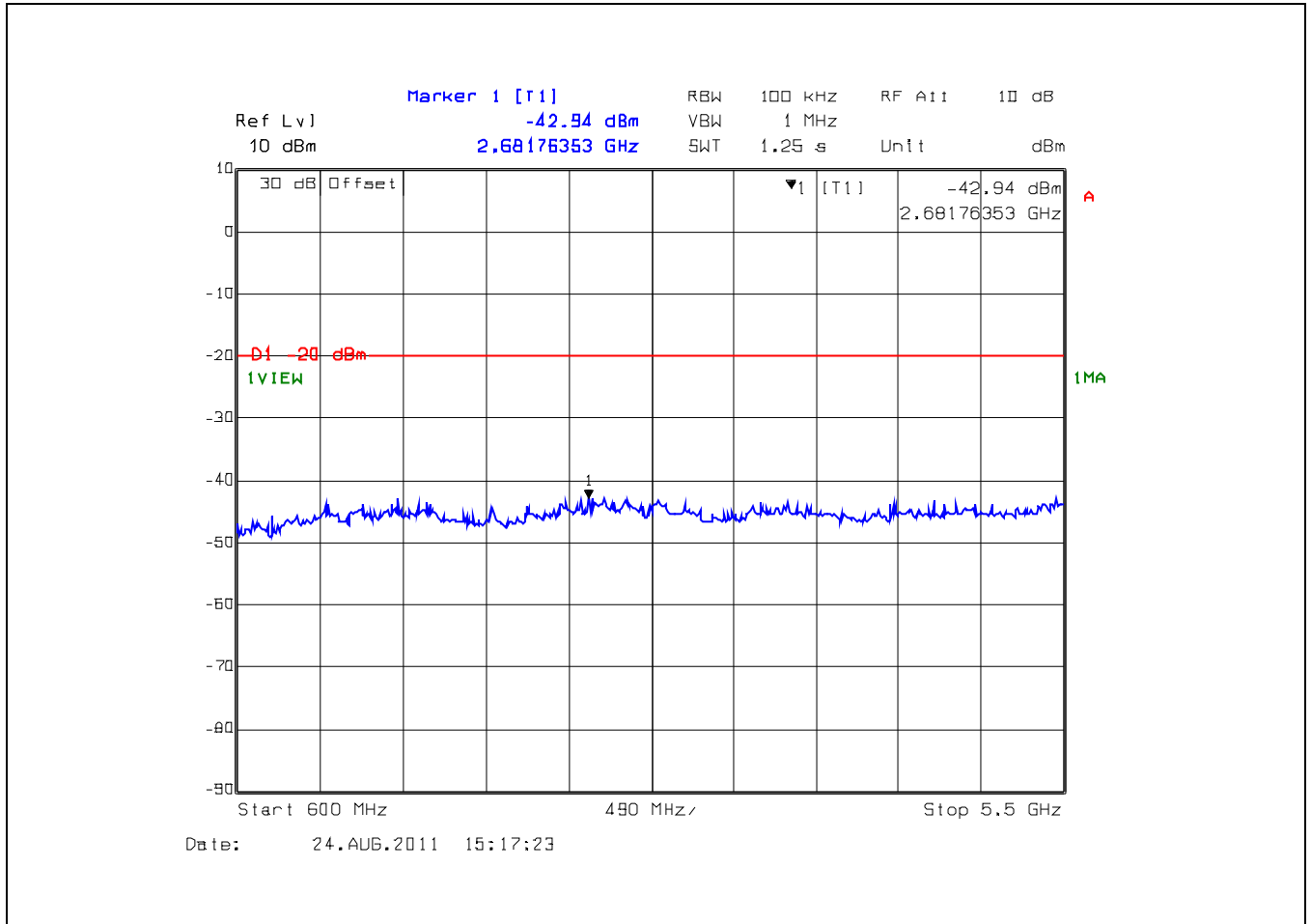

**ULTRATECH GROUP OF LABS**

3000 Bristol Circle, Oakville, Ontario, Canada L6H 6G4  
Tel. #: 905-829-1570, Fax. #: 905-829-8050, Email: [vic@ultratech-labs.com](mailto:vic@ultratech-labs.com), Website: <http://www.ultratech-labs.com>

File #: CMPR-007F90  
August 16, 2012

All test results contained in this engineering test report are traceable to National Institute of Standards and Technology (NIST)



Plot 5.4.4.11. Conducted Transmitter Spurious Emissions for 444.0 MHz, 12.5 kHz Channel Spacing, 30 - 600 MHz

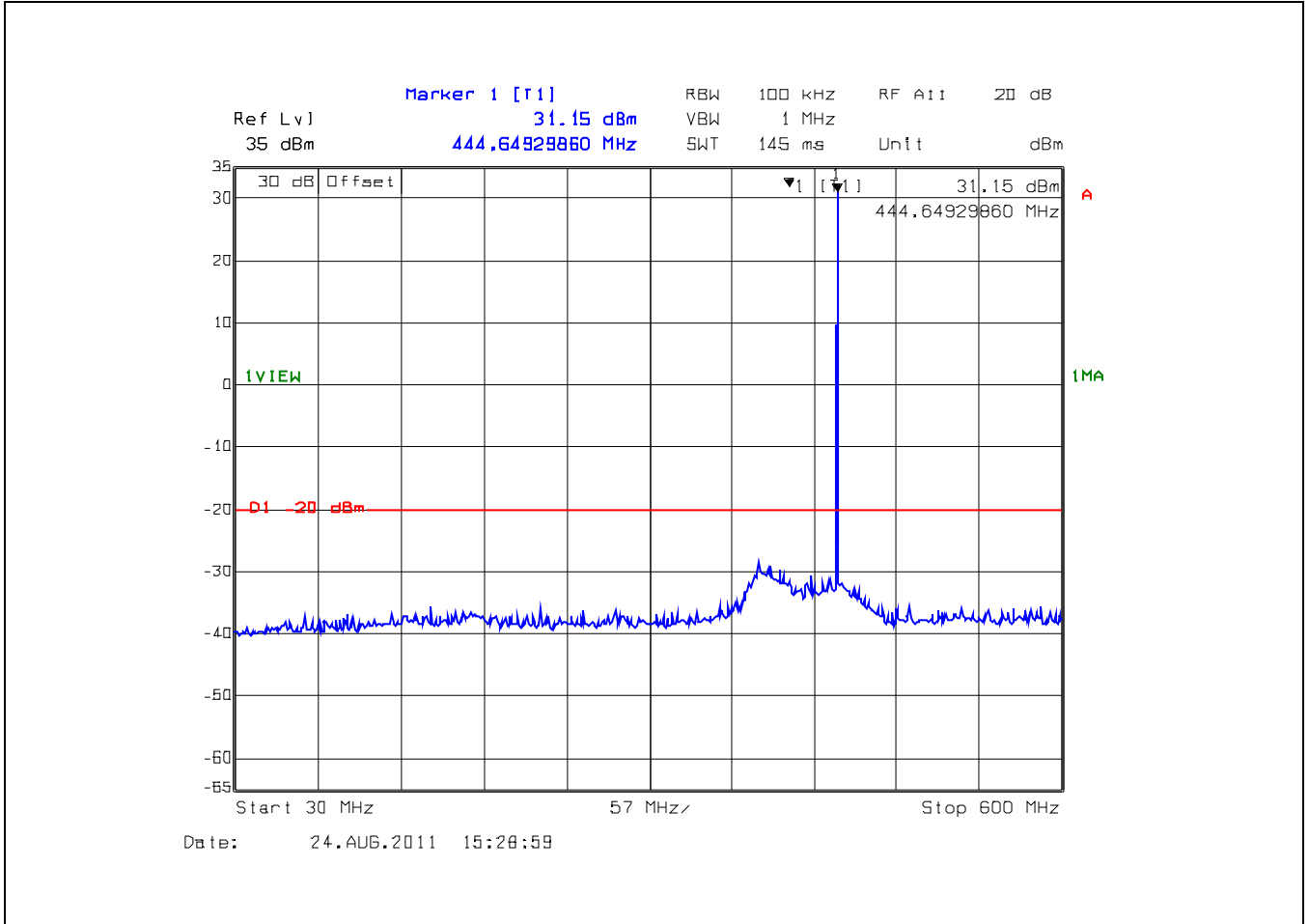

**ULTRATECH GROUP OF LABS**

3000 Bristol Circle, Oakville, Ontario, Canada L6H 6G4  
 Tel. #: 905-829-1570, Fax. #: 905-829-8050, Email: [vic@ultratech-labs.com](mailto:vic@ultratech-labs.com), Website: <http://www.ultratech-labs.com>

File #: CMPR-007F90  
 August 16, 2012

All test results contained in this engineering test report are traceable to National Institute of Standards and Technology (NIST)

Plot 5.4.4.12. Conducted Transmitter Spurious Emissions for 444.0 MHz, 12.5 kHz Channel Spacing, 600 MHz - 5.5 GHz

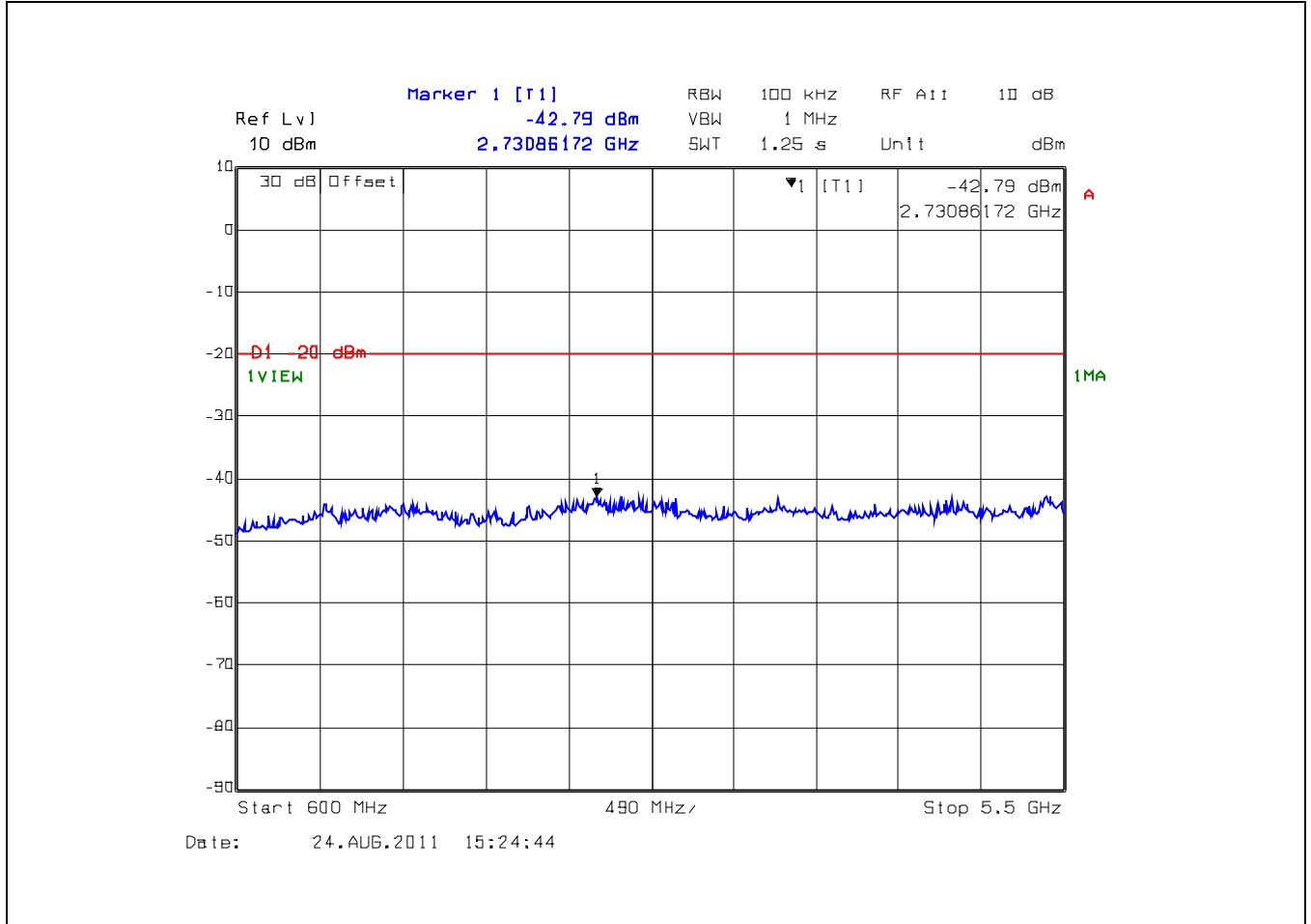

**ULTRATECH GROUP OF LABS**

3000 Bristol Circle, Oakville, Ontario, Canada L6H 6G4  
Tel. #: 905-829-1570, Fax. #: 905-829-8050, Email: [vic@ultratech-labs.com](mailto:vic@ultratech-labs.com), Website: <http://www.ultratech-labs.com>

File #: CMPR-007F90  
August 16, 2012

All test results contained in this engineering test report are traceable to National Institute of Standards and Technology (NIST)



Plot 5.4.4.14. Conducted Transmitter Spurious Emissions for 406.2 MHz, 6.25 kHz Channel Spacing, 600 MHz - 5.5 GHz

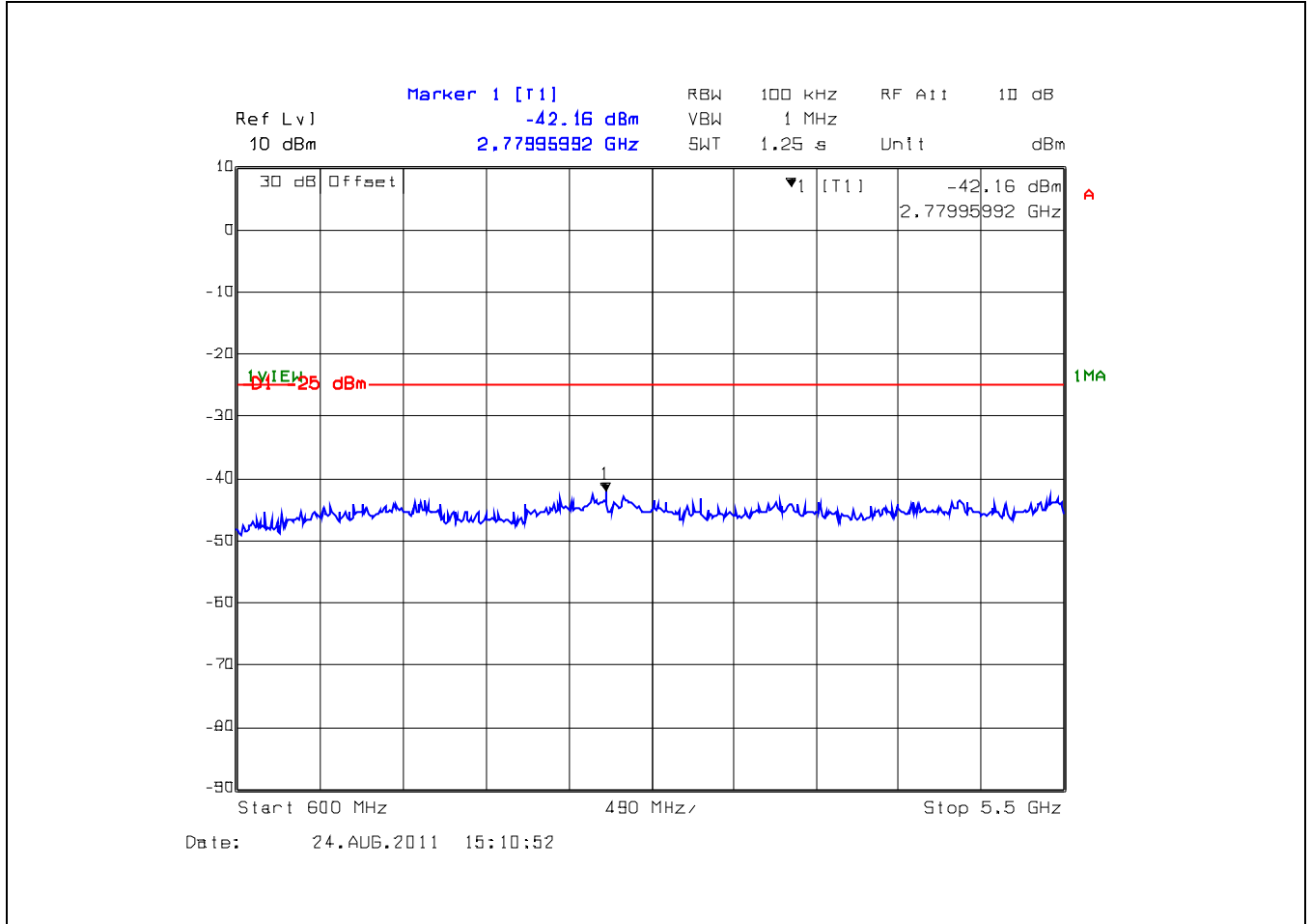

**ULTRATECH GROUP OF LABS**

3000 Bristol Circle, Oakville, Ontario, Canada L6H 6G4  
Tel. #: 905-829-1570, Fax. #: 905-829-8050, Email: [vic@ultratech-labs.com](mailto:vic@ultratech-labs.com), Website: <http://www.ultratech-labs.com>

File #: CMPR-007F90  
August 16, 2012

All test results contained in this engineering test report are traceable to National Institute of Standards and Technology (NIST)



Plot 5.4.4.16. Conducted Transmitter Spurious Emissions for 429.9 MHz, 6.25 kHz Channel Spacing, 600 MHz - 5.5 GHz

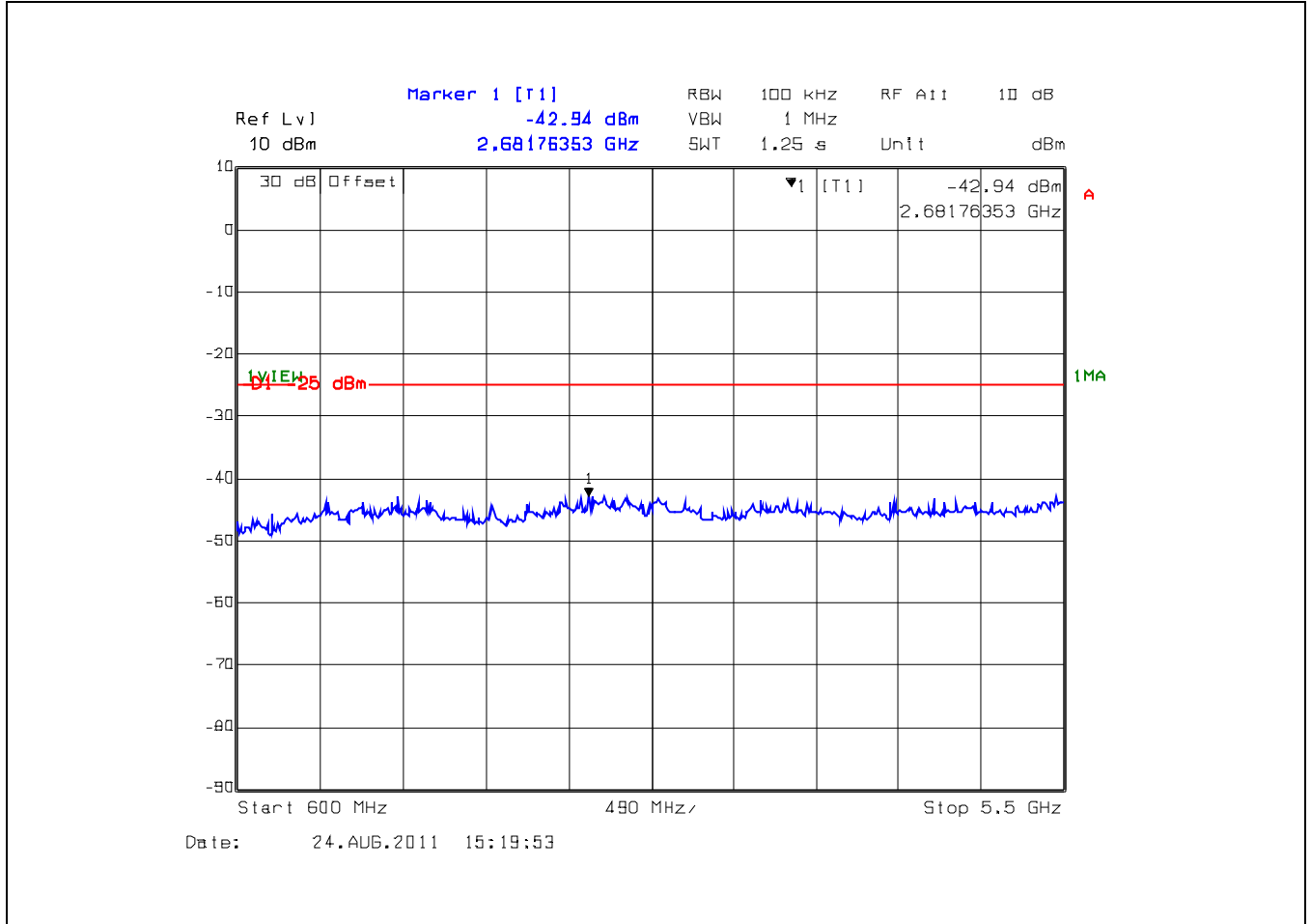

**ULTRATECH GROUP OF LABS**

3000 Bristol Circle, Oakville, Ontario, Canada L6H 6G4  
Tel. #: 905-829-1570, Fax. #: 905-829-8050, Email: [vic@ultratech-labs.com](mailto:vic@ultratech-labs.com), Website: <http://www.ultratech-labs.com>

File #: CMPR-007F90  
August 16, 2012

All test results contained in this engineering test report are traceable to National Institute of Standards and Technology (NIST)







**Plot 5.4.4.19.** Intermodulation, Two Signals at Lower Edge of Passband for 6.25 kHz Channel Spacing  
 Input Signals: 406.2 MHz at -39.66 dBm and 406.20625 MHz at -39.81 dBm

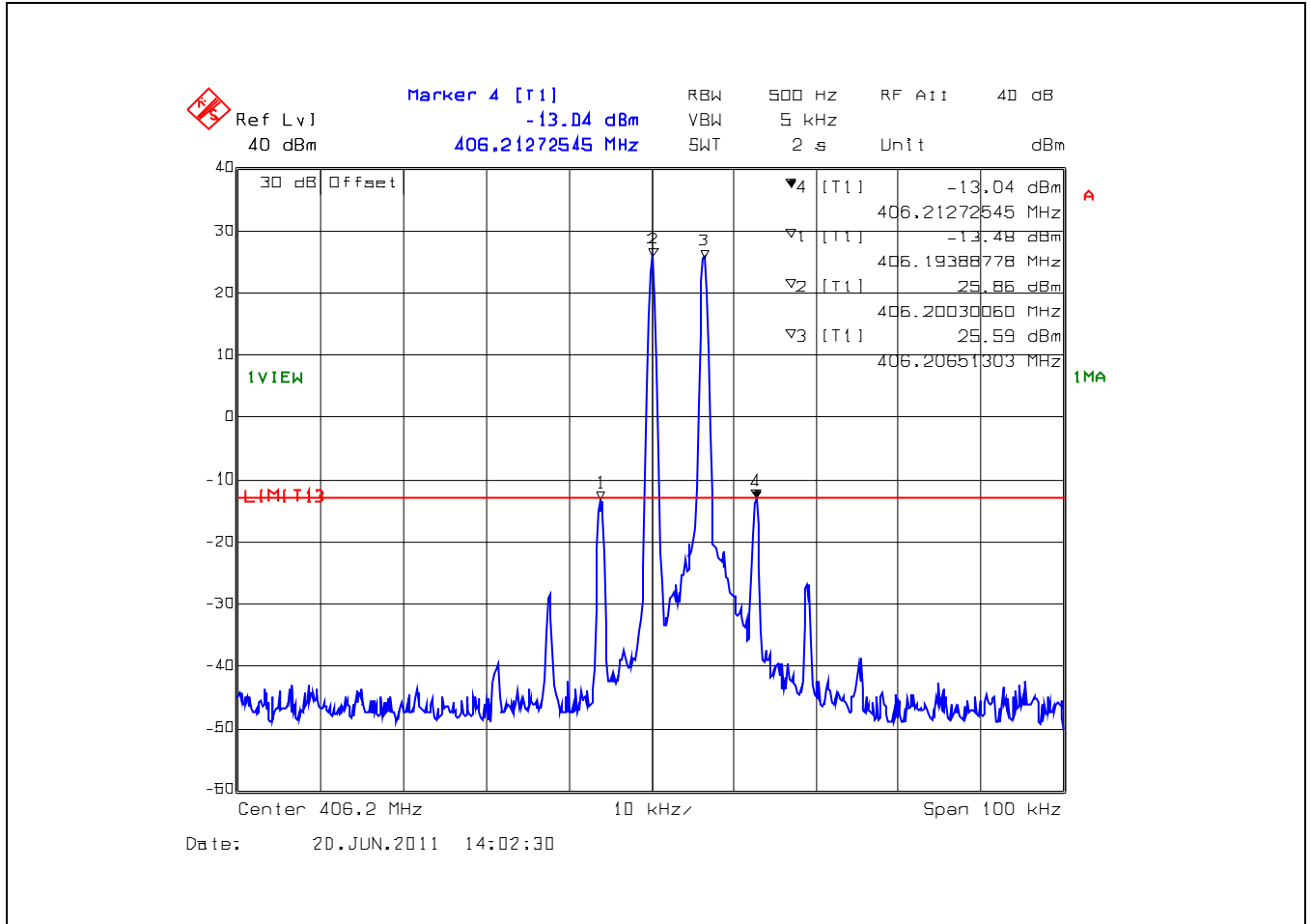

**ULTRATECH GROUP OF LABS**

3000 Bristol Circle, Oakville, Ontario, Canada L6H 6G4  
 Tel. #: 905-829-1570, Fax. #: 905-829-8050, Email: [vic@ultratech-labs.com](mailto:vic@ultratech-labs.com), Website: <http://www.ultratech-labs.com>

File #: CMPR-007F90  
 August 16, 2012

All test results contained in this engineering test report are traceable to National Institute of Standards and Technology (NIST)

**Plot 5.4.4.20.** Intermodulation, Two Signals at Upper Edge of Passband for 6.25 kHz Channel Spacing  
 Input Signals: 443.99375 MHz at -39.75dBm and 444.0 MHz at -39.93dBm

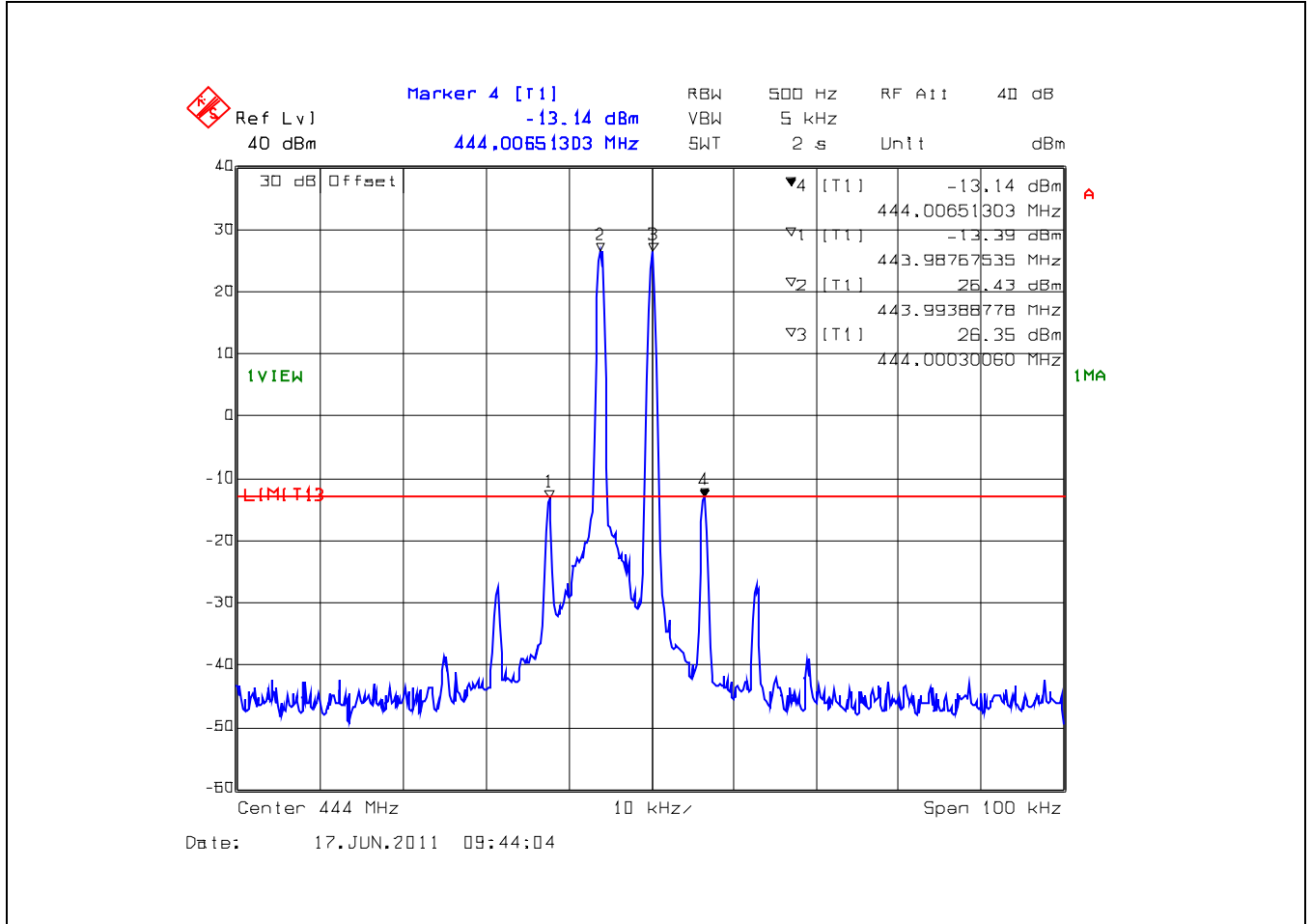

**ULTRATECH GROUP OF LABS**

3000 Bristol Circle, Oakville, Ontario, Canada L6H 6G4  
 Tel. #: 905-829-1570, Fax. #: 905-829-8050, Email: [vic@ultratech-labs.com](mailto:vic@ultratech-labs.com), Website: <http://www.ultratech-labs.com>

File #: CMPR-007F90  
 August 16, 2012

All test results contained in this engineering test report are traceable to National Institute of Standards and Technology (NIST)

**Plot 5.4.4.21.** Intermodulation, Two Signals at Lower Edge of Passband for 12.5 kHz Channel Spacing  
 Input Signals: 406.2 MHz at -39.66dBm and 406.2125 MHz at -39.99dBm

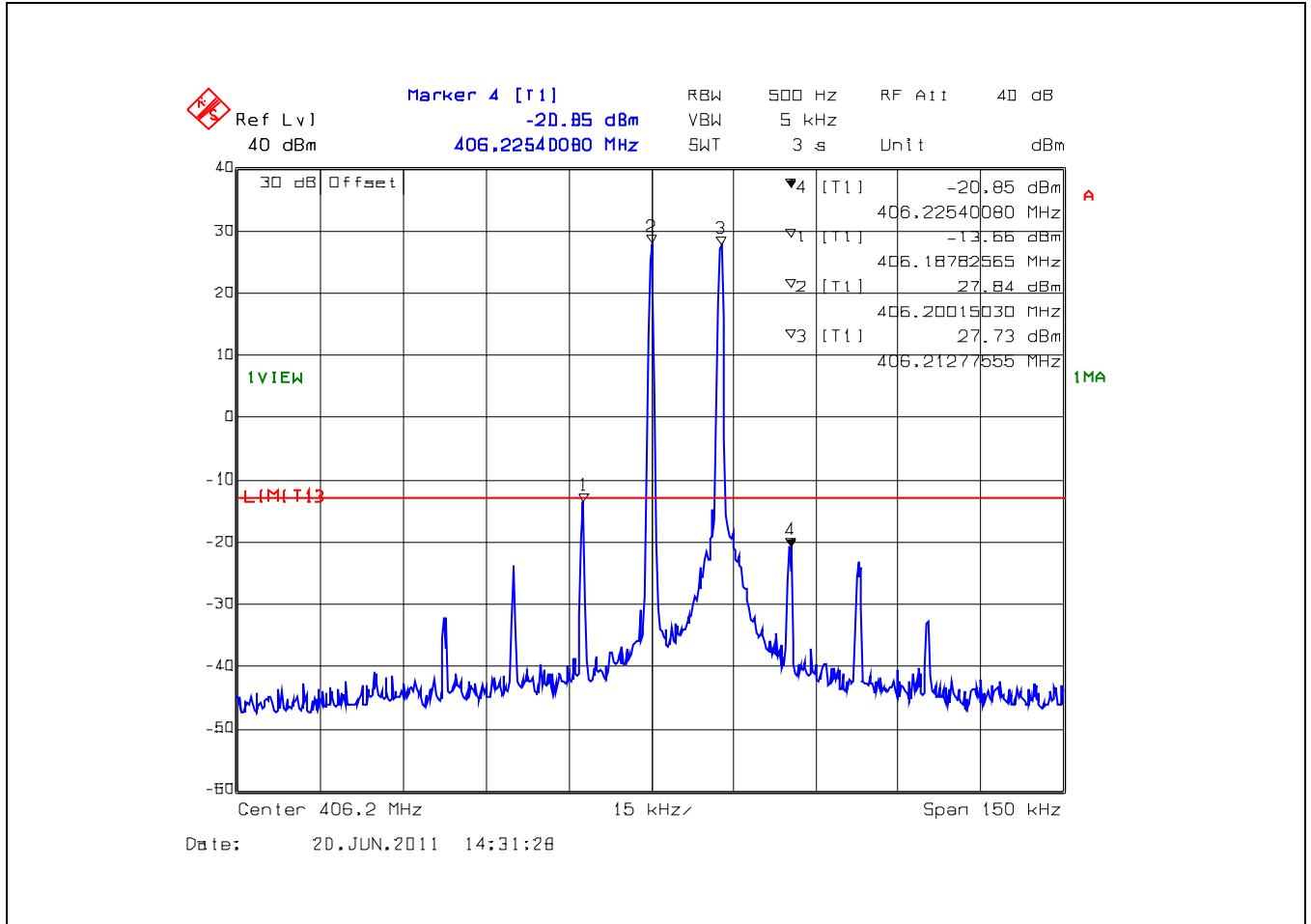

**ULTRATECH GROUP OF LABS**

3000 Bristol Circle, Oakville, Ontario, Canada L6H 6G4  
 Tel. #: 905-829-1570, Fax. #: 905-829-8050, Email: [vic@ultratech-labs.com](mailto:vic@ultratech-labs.com), Website: <http://www.ultratech-labs.com>

File #: CMPR-007F90  
 August 16, 2012

All test results contained in this engineering test report are traceable to National Institute of Standards and Technology (NIST)

**Plot 5.4.4.22.** Intermodulation, Two Signals at Upper Edge of Passband for 12.5 kHz Channel Spacing  
 Input Signals: 443.9875 MHz at -39.85dBm and 444.0 MHz at -39.93dBm

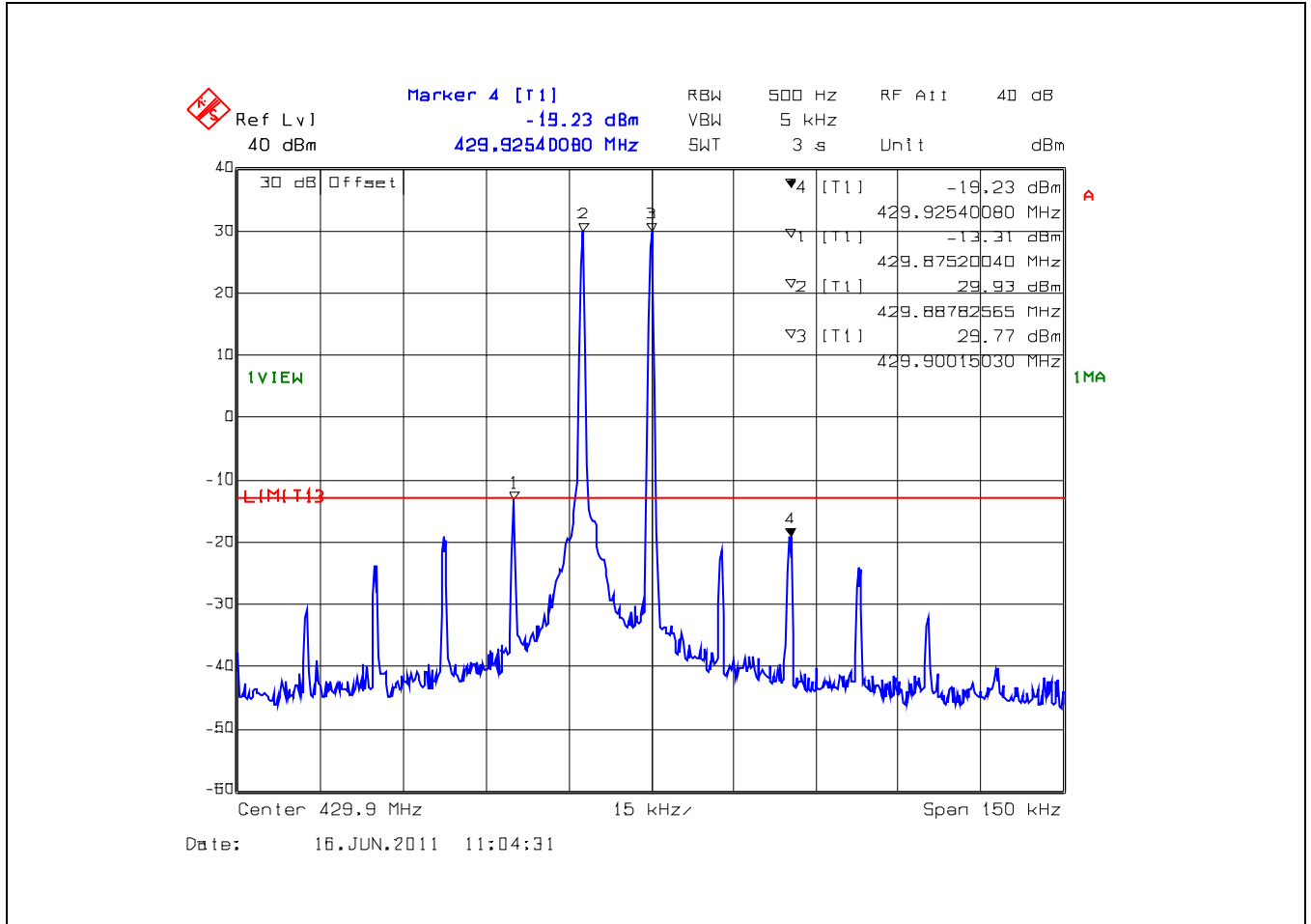

**ULTRATECH GROUP OF LABS**

3000 Bristol Circle, Oakville, Ontario, Canada L6H 6G4  
 Tel. #: 905-829-1570, Fax. #: 905-829-8050, Email: [vic@ultratech-labs.com](mailto:vic@ultratech-labs.com), Website: <http://www.ultratech-labs.com>

File #: CMPR-007F90  
 August 16, 2012

All test results contained in this engineering test report are traceable to National Institute of Standards and Technology (NIST)

**Plot 5.4.4.23.** Intermodulation, Two Signals at Lower Edge of Passband for 25 kHz Channel Spacing  
 Input Signals: 406.2 MHz at -39.66dBm and 406.225 MHz at -39.52dBm

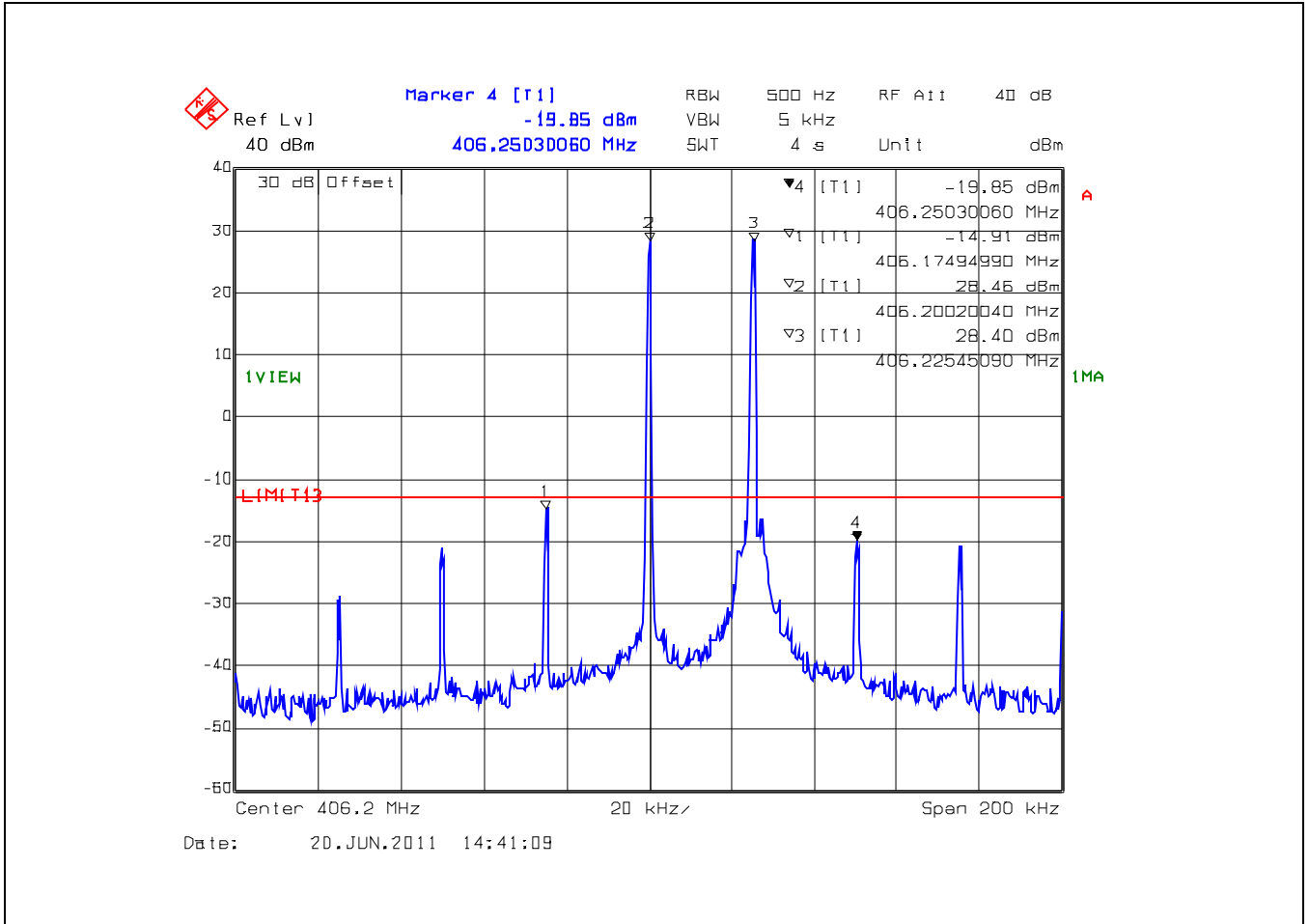

**ULTRATECH GROUP OF LABS**

3000 Bristol Circle, Oakville, Ontario, Canada L6H 6G4  
 Tel. #: 905-829-1570, Fax. #: 905-829-8050, Email: [vic@ultratech-labs.com](mailto:vic@ultratech-labs.com), Website: <http://www.ultratech-labs.com>

File #: CMPR-007F90  
 August 16, 2012

All test results contained in this engineering test report are traceable to National Institute of Standards and Technology (NIST)

**Plot 5.4.4.24.** Intermodulation, Two Signals at Upper Edge of Passband for 25 kHz Channel Spacing  
 Input Signals: 443.975 MHz at -40.27dBm and 444.0 MHz at -39.93dBm

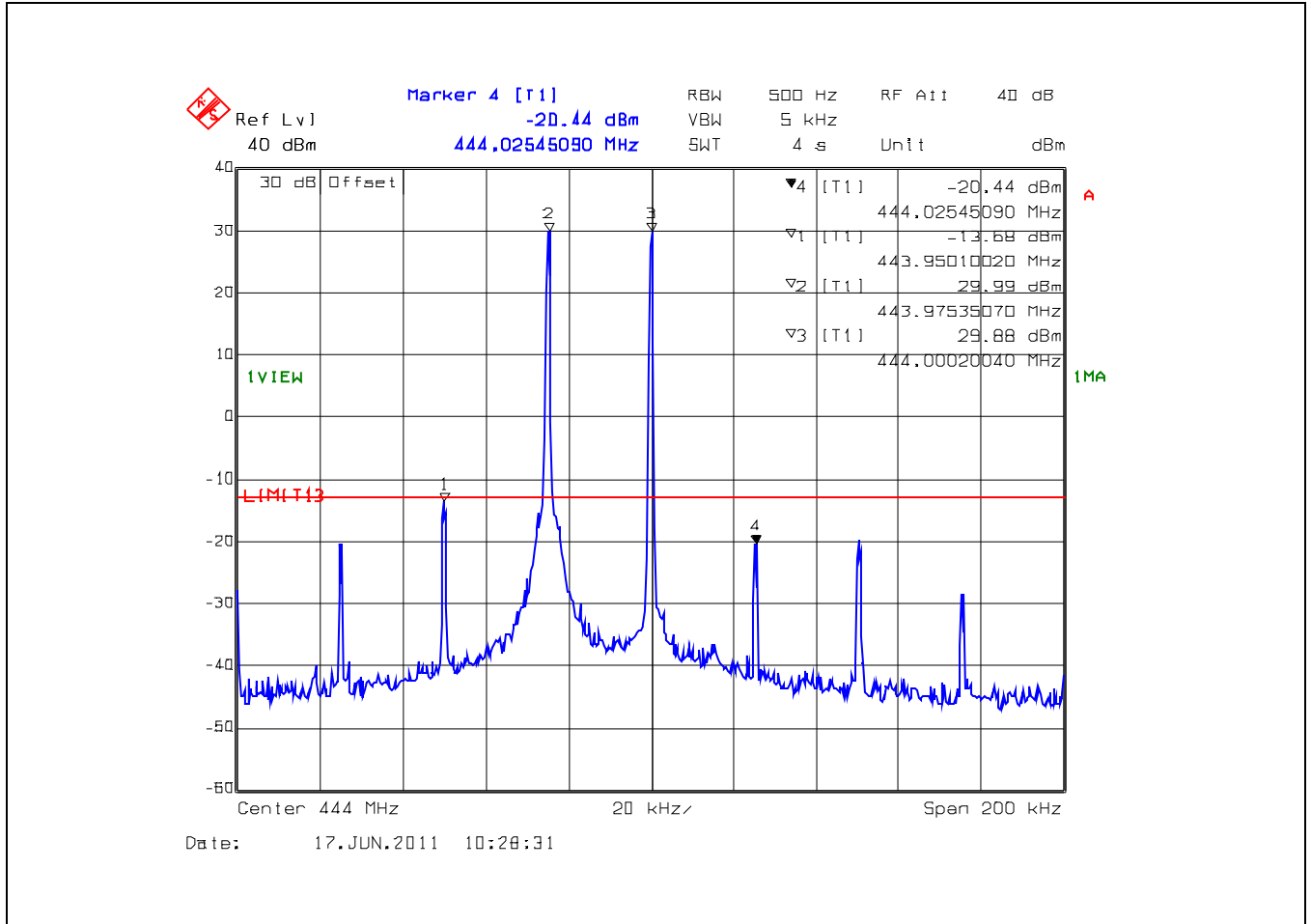

**ULTRATECH GROUP OF LABS**

3000 Bristol Circle, Oakville, Ontario, Canada L6H 6G4  
 Tel. #: 905-829-1570, Fax. #: 905-829-8050, Email: [vic@ultratech-labs.com](mailto:vic@ultratech-labs.com), Website: <http://www.ultratech-labs.com>

File #: CMPR-007F90  
 August 16, 2012

All test results contained in this engineering test report are traceable to National Institute of Standards and Technology (NIST)

## 5.5. FIELD STRENGTH OF SPURIOUS RADIATION [§§ 90.210, 2.1053 & 2.1057]

### 5.5.1. Limits

§ 90.219 (c) Class A narrowband boosters must meet the out-of-band emission limits of § 90.210 for each narrowband channel that the booster is designed to amplify. Class B broadband signal boosters must meet the emission limits of § 90.210 for frequencies outside of the booster's designed passband.

### 5.5.2. Method of Measurements

The test shall be performed using substitution method specified in TIA-603-C.

### 5.5.3. Test Arrangement

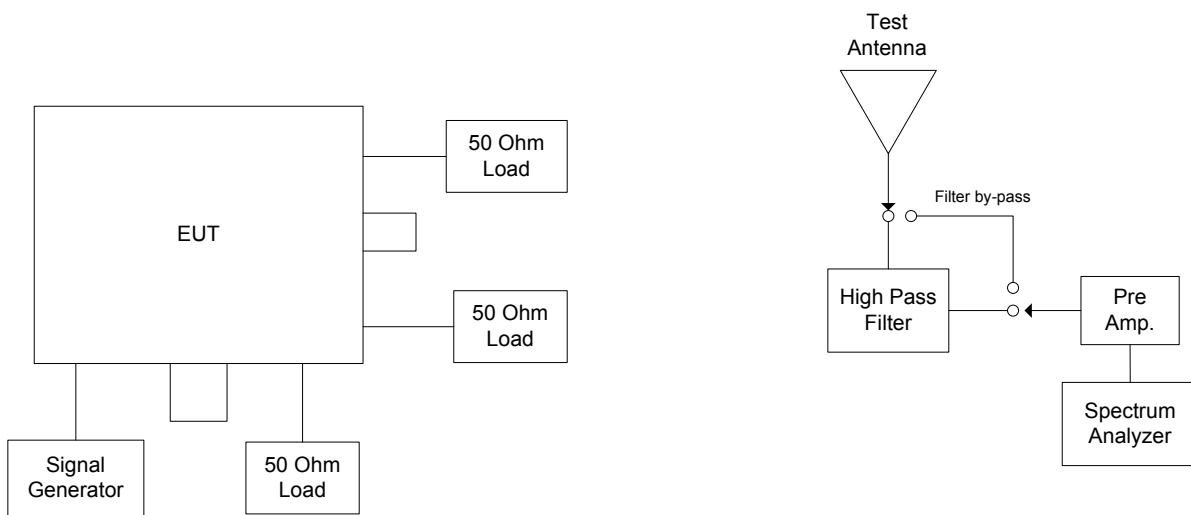

**5.5.4. Test Data**

**Remarks:**

- The RF spurious/harmonic emission characteristics for different channel spacing are similar. Therefore, the following radiated emissions were performed at 25 kHz channel spacing and the results were compared with the more stringent limit for the worst-case.
- The radiated emissions were performed at high power setting with single RF input signal at 3 m distance to represents the worst-case test configuration.
- The emissions were scanned from at least 30 MHz to 10<sup>th</sup> harmonics; all spurious emissions that are in excess of 20dB below the specified limit shall be recorded.

**5.5.4.1. Near Lowest Frequency (406.2 MHz)**

<b>Test Frequency (MHz):</b>		406.2				
<b>Limit (dBm):</b>		-25				
Frequency (MHz)	E-Field (dBµV/m)	EMI Detector (Peak/QP)	Antenna Polarization (H/V)	ERP measured (dBm)	Limit (dBm)	Margin (dB)
30-6000	*	Peak	V/H	*	-25	*
* Spurious emissions are more than 20dB below the specified limit.						

**5.5.4.2. Near Middle Frequency (429.9 MHz)**

<b>Test Frequency (MHz):</b>		429.9				
<b>Limit (dBm):</b>		-25				
Frequency (MHz)	E-Field (dBµV/m)	EMI Detector (Peak/QP)	Antenna Polarization (H/V)	ERP measured (dBm)	Limit (dBm)	Margin (dB)
2149.5	60.52	Peak	V	-40.41	-25	-15.4
2149.5	61.51	Peak	H	-39.91	-25	-14.9

**5.5.4.3. Near Highest Frequency (444.0 MHz)**

<b>Test Frequency (MHz):</b>		444.0				
<b>Limit (dBm):</b>		-25				
Frequency (MHz)	E-Field (dBµV/m)	EMI Detector (Peak/QP)	Antenna Polarization (H/V)	ERP measured (dBm)	Limit (dBm)	Margin (dB)
2220.0	57.96	Peak	V	-43.92	-25	-18.9



**5.6. RF EXPOSURE REQUIRMENTS [§§ 1.1310 & 2.1091]**

The criteria listed in the following table shall be used to evaluate the environmental impact of human exposure to radio-frequency (RF) radiation.

**FCC 47 CFR § 1.1310:**

**TABLE 1—LIMITS FOR MAXIMUM PERMISSIBLE EXPOSURE (MPE)**

Frequency range (MHz)	Electric field strength (V/m)	Magnetic field strength (A/m)	Power density (mW/cm <sup>2</sup> )	Averaging time (minutes)
<b>(A) Limits for Occupational/Controlled Exposures</b>				
0.3–3.0 .....	614	1.63	*(100)	6
3.0–30 .....	1842/f	4.89/f	*(900/f <sup>2</sup> )	6
30–300 .....	61.4	0.163	1.0	6
300–1500 .....	.....	.....	f/300	6
1500–100,000 .....	.....	.....	5	6
<b>(B) Limits for General Population/Uncontrolled Exposure</b>				
0.3–1.34 .....	614	1.63	*(100)	30
1.34–30 .....	824/f	2.19/f	*(180/f <sup>2</sup> )	30
30–300 .....	27.5	0.073	0.2	30
300–1500 .....	.....	.....	f/1500	30
1500–100,000 .....	.....	.....	1.0	30

f = frequency in MHz

\* = Plane-wave equivalent power density

NOTE 1 TO TABLE 1: Occupational/controlled limits apply in situations in which persons are exposed as a consequence of their employment provided those persons are fully aware of the potential for exposure and can exercise control over their exposure. Limits for occupational/controlled exposure also apply in situations when an individual is transient through a location where occupational/controlled limits apply provided he or she is made aware of the potential for exposure.

NOTE 2 TO TABLE 1: General population/uncontrolled exposures apply in situations in which the general public may be exposed, or in which persons that are exposed as a consequence of their employment may not be fully aware of the potential for exposure or can not exercise control over their exposure.

**5.6.1. Method of Measurements**

Refer to Sections 1.1310, 2.1091

In order to demonstrate compliance with MPE requirements (see Section 2.1091), the following information is typically needed:

- (1) Calculation that estimates the minimum separation distance (20 cm or more) between an antenna and persons required to satisfy power density limits defined for free space.
- (2) Antenna installation and device operating instructions for installers (professional/unskilled users), and the parties responsible for ensuring compliance with the RF exposure requirement
- (3) Any caution statements and/or warning labels that are necessary in order to comply with the exposure limits
- (4) Any other RF exposure related issues that may affect MPE compliance

**Calculation Method of RF Safety Distance:**

$$S = \frac{P \cdot G}{4 \cdot \pi \cdot r^2} = \frac{EIRP}{4 \cdot \pi \cdot r^2}$$

Where: P: power input to the antenna in mW  
 EIRP: Equivalent (effective) isotropic radiated power  
 S: power density mW/cm<sup>2</sup>  
 G: numeric gain of antenna relative to isotropic radiator  
 r: distance to centre of radiation in cm

**5.6.2. RF Evaluation**

EVALUATION OF RF EXPOSURE COMPLIANCE REQUIREMENTS	
RF Exposure Requirements	Compliance with FCC Rules
Minimum calculated separation distance between antenna and persons required: <b>*50.8 cm</b>	Manufacturer' instruction for separation distance between antenna and persons required: <b>66 cm.</b>
Antenna installation and device operating instructions for installers (professional/unskilled users), and the parties responsible for ensuring compliance with the RF exposure requirement	Antenna installation and device operating instructions shall be provided to installers to maintain and ensure compliance with RF exposure requirements.
Caution statements and/or warning labels that are necessary in order to comply with the exposure limits	Refer to User's Manual for RF Exposure Information.
Any other RF exposure related issues that may affect MPE compliance	None.

\*The minimum separation distance between the antenna and bodies of users are calculated using the following formula:

$$r = \sqrt{\frac{P \cdot G}{4 \cdot \pi \cdot S}} = \sqrt{\frac{EIRP}{4 \cdot \pi \cdot S}}$$

S = 380/1500 mW/cm<sup>2</sup>

EIRP = P<sub>(Max. ERP permitted)</sub> + 2.15 dB = 37 dBm + 2.15 dB = 39.15 dBm = 8222 mW (Worst Case)

**(Minimum Safe Distance, r) =**  $\sqrt{\frac{EIRP}{4 \cdot \pi \cdot S}} = \sqrt{\frac{8222}{4 \cdot \pi \cdot (380 / 1500)}} \approx 50.8cm$

**EXHIBIT 6. TEST EQUIPMENT LIST**

Test Instruments	Manufacturer	Model No.	Serial No.	Frequency Range	Cal. Due Date
Spectrum Analyzer	Rohde & Schwarz	FSEK	834157/005	9 KHz – 40 GHz	18 Jul 2012
Attenuator (20dB)	Aeroflex/Weinschel	46-30-34	BR9127	DC-18 GHz	Cal on use
High Pass Filter	Mini Circuit	SHP 250	--	Cut off 230 MHz	Cal on use
Power Meter	Hewlett Packard	437B	3125U06665	100K--50G sensor dependent	24 Aug 2012
Power Sensor	Hewlett Packard	8481A	US37295684	0.1 - 18 GHz	27 Aug 2011
Modulation Analyzer	Hewlett Packard	8901B	3226A04606	150KHz-1300MHz	17 Dec 2011
Frequency Counter	EIP	545A	2683	10Hz - 18 GHz	31 Jan 2012
Combiner	Mini Circuit	ZFSC-3-4	15542	1MHz - 1GHz	Cal on use
RF Detector	Pasternack	PE8000-50	--	10M--1G Hz	Cal on use
Infinium Digital Oscilloscope	Hewlett-Packard	54801A	US38380192	DC--500M Hz 1G sampling	27 May 2012
Environmental Chamber	Envirotronics	SSH32C	11994847-S-11059	-60 to 177 degree C	11 Aug 2012
RF Synthesized signal Generator	HP	8648C	3343U00391	100K-3200M Hz AM/ FM/ PM	16 Dec 2011
Power supply	Tenma	72-7295	490300297	1-40V DC 5A	Cal on use
FFT Digital Spectrum Analyzer	Advantest	R9211E	8202336	10mHz--100KHz	12 Nov 2011
RF Communication Test Set	Hewlett Packard	8920B	US39064699	30MHz-1GHz	27 Oct 2012
Horn antenna	ETS-LINDGREN	3117	119425	1-18GHz	15 Feb 2012
Preamplifier	Hewlett Packard	8449B	3008A00769	1-26.5GHz	17 Feb 2012
High Pass Filter	Mini Circuit	SHP 600	--	Cut off 560 MHz	Cal on use
Power supply	XANTREX	XKW 60-50	26509	0-60V 0-50A DC	Cal on use
Attenuator (20dB)	narda	26298	A577	DC-1GHz 150W	Cal on use
Attenuator (10dB)	Aeroflex/Weinschel	46-10-34	BS4336	DC-18 GHz	Cal on use
Attenuator (3dB )	Weinschel	2	A86-4204	DC-12GHz	Cal on use
Synthesized Sweeper	Hewlett Packard	83752B	3610A00457	0.01-20GHz	19 Oct 2011
Signal Generator	IFR	2025	202304/141	9 kHz – 2.51 GHz	16 Nov 2011
Spectrum Analyzer	Hewlett Packard	HP 8593EM	3710A00223	9 kHz - 22 GHz	25 Apr 2012
Attenuator	Pasternack	PE7010-20	--	DC – 2 GHz	08 Jan 2012
L.I.S.N.	EMCO	3825/2	8907-1531	10 kHz – 100 MHz	30 Mar 2012
Log Periodic Antenna	ETS	93148	1101	200 MHz – 2 GHz	04 Jan 2012
Horn Antenna	EMCO	3115	9701-5955	1 GHz – 18 GHz	09 Jan 2012

**ULTRATECH GROUP OF LABS**

3000 Bristol Circle, Oakville, Ontario, Canada L6H 6G4  
 Tel. #: 905-829-1570, Fax. #: 905-829-8050, Email: [vic@ultratech-labs.com](mailto:vic@ultratech-labs.com), Website: <http://www.ultratech-labs.com>

File #: CMPR-007F90  
 August 16, 2012

All test results contained in this engineering test report are traceable to National Institute of Standards and Technology (NIST)

**EXHIBIT 7. MEASUREMENT UNCERTAINTY**

The measurement uncertainties stated were calculated in accordance with the requirements of CISPR 16-4-2 @ IEC:2003 and JCGM 100:2008 (GUM 1995) – Guide to the Expression of Uncertainty in Measurement.

**7.1. LINE CONDUCTED EMISSION MEASUREMENT UNCERTAINTY**

	Line Conducted Emission Measurement Uncertainty (150 kHz – 30 MHz):	Measured	Limit
<b>u<sub>c</sub></b>	<b>Combined standard uncertainty:</b> $u_c(y) = \sqrt{\sum_{i=1}^m u_i^2(y)}$	<b>± 1.57</b>	<b>± 1.8</b>
<b>U</b>	<b>Expanded uncertainty U:</b> $U = 2u_c(y)$	<b>± 3.14</b>	<b>± 3.6</b>

**7.2. RADIATED EMISSION MEASUREMENT UNCERTAINTY**

	Radiated Emission Measurement Uncertainty @ 3m, Horizontal (30-1000 MHz):	Measured	Limit
<b>u<sub>c</sub></b>	<b>Combined standard uncertainty:</b> $u_c(y) = \sqrt{\sum_{i=1}^m u_i^2(y)}$	<b>± 2.15</b>	<b>± 2.6</b>
<b>U</b>	<b>Expanded uncertainty U:</b> $U = 2u_c(y)$	<b>± 4.30</b>	<b>± 5.2</b>

	Radiated Emission Measurement Uncertainty @ 3m, Vertical (30-1000 MHz):	Measured	Limit
<b>u<sub>c</sub></b>	<b>Combined standard uncertainty:</b> $u_c(y) = \sqrt{\sum_{i=1}^m u_i^2(y)}$	<b>± 2.39</b>	<b>± 2.6</b>
<b>U</b>	<b>Expanded uncertainty U:</b> $U = 2u_c(y)$	<b>± 4.78</b>	<b>± 5.2</b>

	Radiated Emission Measurement Uncertainty @ 3 m, Horizontal & Vertical (1 – 18 GHz):	Measured	Limit
<b>u<sub>c</sub></b>	<b>Combined standard uncertainty:</b> $u_c(y) = \sqrt{\sum_{i=1}^m u_i^2(y)}$	<b>± 1.87</b>	Under consideration
<b>U</b>	<b>Expanded uncertainty U:</b> $U = 2u_c(y)$	<b>± 3.75</b>	Under consideration