

COMPROD COMMUNICATIONS LTD.

Customer Instruction Manual

Model #BDA-764806

700 MHz BIDIRECTIONAL AMPLIFIER Technical manual

© 2015, Comprod Communications LTD.

88 Industriel Blvd
Boucherville, QC, J4B 2X2
Phone 1.800.641.1454 • Fax 1.800.641.4616

3405 N. Benzing Road
Orchard Park, NY, USA 14127
Phone 1.800.603.1454 • Fax 1.800.554.1033

IMPORTANT:

The integrator is responsible for its product to comply with IC ICES-003 & FCC Part 15, Subpart B – Unintentional Radiators. Final product must comply with unintentional radiators before declaring compliance of their final product to Part 15 of the FCC Rules and Industry Canada ICES-003.

Based on the philosophy of Anytime, Anywhere, and Anyplace, the amplifier module 806-869 MHz is designed for ease of use and being adaptable to various needs in the field. Recently developed technologies are applied and with the use of modern integrated circuits and RF components, the Comprod design ensures constant performances and reliable amplifier unit.

Our 700 MHz amplifier has also been designed with government agencies in mind. These are our highest level of performance and quality for continuous duty solutions while providing maximizing coverage.

This amplifier module is aimed for the use in buildings, tunnel, government facilities, airports, providing the communication throughout.

The amplifier module helps to increase the coverage of RF communications in buildings or places where RF is unable to penetrate from the base station site. The Amplifier Module can be used in both Uplink and Downlink directions and connected to either a radiant cable, a distributed antenna system at one end. At the other end it's connected to the donor antenna.

Main Specifications:

No	Parameters	Specification	Remarks
1	Operating Frequency	DL: 764~775MHz UL: 794~805MHz	
2	Pass Bandwidth	12MHz	
3	Passband Ripple	± 1.5dB	
4	Signal & Modulation	F1D,F2D,LTE	
5	Gain	83.5dB	
6	Gain variation over Temp.	± 2dB	
7	Manual Gain Control (MGC)	31dB / 1dB step	controlled by Rotary switch
8	Automatic Gain Control	30dB	
9	Delay	1us max.	
10	Input Power No damage	10 dBm	
11	Output Power	DL: 31.5 dBm max. UL: 31.5 dBm max.	
12	VSWR	1.5 max	
13	Noise figure	2dB max.	Max Gain, without DPLX (2.8 dB max with DPLX)
14	Spurious	3GPP TS 36. 106	
15	Channel Filter rejection	45dBc@C.F±36MHz	Ceramic filter
16	In/Output det. range	Input: -65~-25dBm Output: 0~+34.5dBm	
17	LNA by pass function	-20dBm @ input power	

18	Alarm (Led Indicator)	AGC Alarm, S/D Alarm	Alarm: High, Normal Low
19	Voltage(Current)	+28V(3A)/+6V(3A)	
20	In/Out Connector	N (F)	
21	Size (in)	10H x 16W x 8.5D	
22	Operating Temp./Humi.	-10 ~ +50°C/95%	

Block Diagram Details

- The 700 MHz Amplifier module contains a (Low Noise Amplifier) LNA designed to detected very week signal. This stage is bypassed if the signal level at the input is higher than -20dBm
- The LNA is followed by an Automatic Gain Control (AGC). The AGC circuit measures composite power level at the VGA input and adjusts automatically the gain, in order to maintain constant the signal level at the VGA output delivered to the Power Amplifier (PA). Channel filters are inserted, in order to reject adjacent channel signals and to improve the main signal quality.
- The PA provides good performance for both linearity and efficiency. This amplifier is heat sink mounted and produces a high compression point and 3rd order Intercept point.
- The unit can operate with AC or DC supplies. The main AC input accepts 50/60 Hz with a 115 to 220 V AC power source; then the Power Supply Unit (PSU) converts AC to DC voltages to supply DC power to the Amplifiers and the Monitoring and controle units. The unit can be fed directly with the DC power, by selecting the DC option on the AC/DC switch and connecting +24-27 V to the DC input connector. The operator must ensure that his external DC power supplies are compliant with FCC limits on the radiated and conducted emission.
- The unit does not have built-in UPS/Battery system. In case of need for inconsistency in the AC line power, surge protection, short Black outs, crossover time from line AC to generator power, circuit breaker for short circuit and over load protection, etc., an external UPS/Battery system is recommended.
- The unit has two duplexers; one at BTS port allowing the use for only one donor antenna for both UL and DL. The second duplexer is mounted at the Service DAS antennas port. These duplexers provide at least 100 dB isolation at each end between the two path..
- A set of manual gain control (MGC), ranging from 0 to 30 dB in 1 dB steps are also added in the chain for additional attenuation if needed.

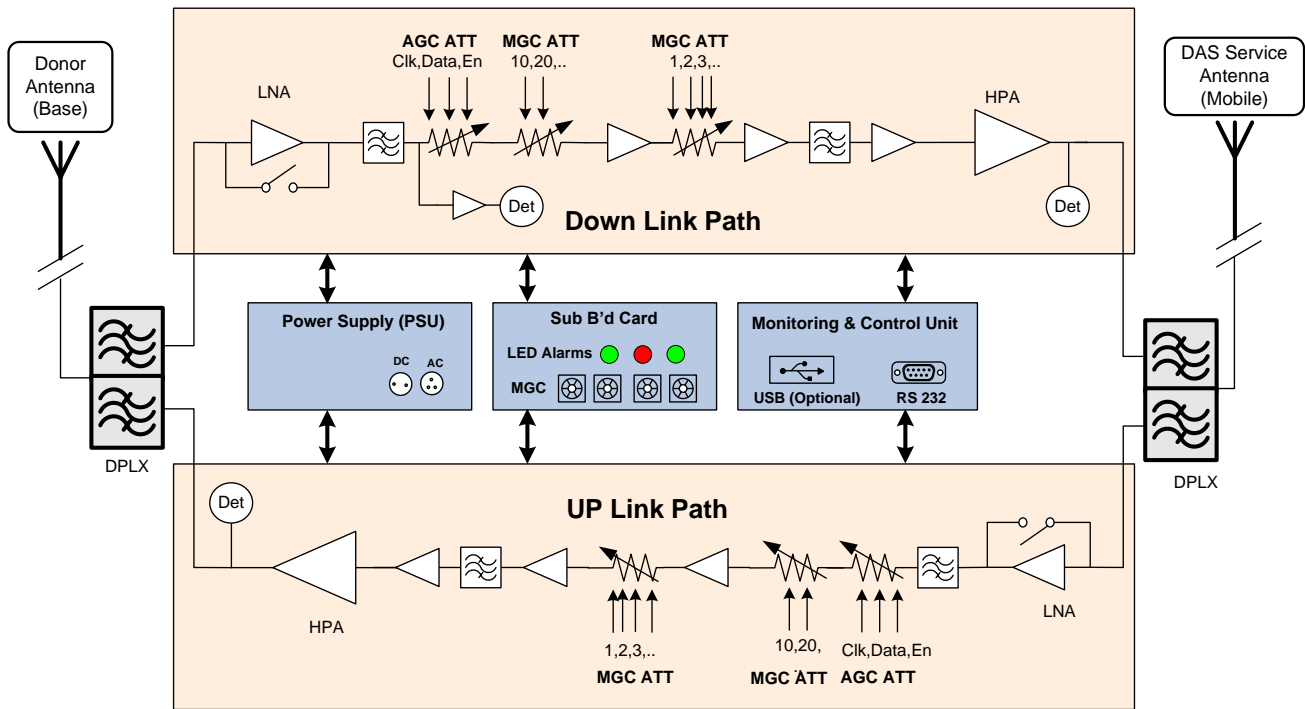

Figure 1: Block diagram of the 700 MHz bidirectional amplifier

Led indicator Alarm and Manual level control.

- The unit has a visual Alarm as led indicators for the following main functionality; AGC, S/D and Power.
 - o AGC alarm tuned red when the AGC is not delivering any attenuation. This can happen in two situations either the AGC is tuned off by the user (see monitoring and control section) or if the signal at input of the DL is too weak. This is not necessarily a failure. It can be just a warning that the signal from the BTS is too weak.
 - o S/D The shutdown indicator turn red when the system is automatically shut down. This happen when the internal temp is too high or when output power exceed the max limit allowed. When the RF module is turned off by the user (see monitoring and control section) the S/D indicator start flashin ✖.
 - o Power indicator turns red when the RFM is not receiving the DC power.

700 MHZ BIDIRECTIONAL AMPLIFIER TECHNICAL MANUAL

○



○

. Monitoring and Control

-. The monitoring and control Function is possible by connecting the BDA through a serial RS232 connector. A Serial to USB cable is available under request.

The software designed for this purpose is provided (ver 1.02). this software should be installed on computer with windows, xp,vista,7, 8 or 10 version, when execute the software we see the screen below.

To activate the control we should first click on Release. If the HPA enable is in Off position you should click to turn it ON in order to have the amplifier working.



4. Monitor, Alarm, Control items

4.1 Monitor

- 1) Downlink Input Power.

(This gives the power level in dBm of the signal coming from the BTS
The lowest level the unit can detect is -76dBm)

- 2) Downlink / Uplink Output Power

- 3) Downlink / Uplink System Gain

- 4) Downlink / Uplink AGC Attenuation

Automatic attenuation delivered by the AGC to maintain the output level constant

When this value shows 0 it's because the input power is lower than -53 dBm. If it's zero in the Downlink path the AGC Alarm turn red.

5) DC voltage / current monitor

It shows the DC voltage and current to the RF unit

6) System temp.

4.2 Alarm

1) Downlink input over power

Turn red when the input power from the BTS exceed the maximum predefined

2) Downlink / Uplink output over power

3) AGC range alarm

4) Downlink / Uplink Shutdown

When shut down occur because of over temp or over output power it turns red. Flushing when it's shut down by the user.

5) PSU alarm

6) Over temp. Alarm

7) Door Alarm

4.3 Control

1) Downlink / Uplink HPA on/off

2) Downlink / Uplink gain control

3) Downlink / Uplink AGC on/off

4) Downlink / Uplink shutdown on/off

5) MCU Reset

6) Alarm limit

4.4 Etc.

1) Software Version

2) Vendor name

3) Model name

4) Time

5) Alarm history

6) Maintenance history

Unpacking

- 1) The 700 MHz BDA should be unpacked soon after delivery and carefully inspected for possible shipping damage. It is the customer's responsibility to file claims with the freight carrier if damage is suspected and is usually limited to a certain time period after delivery.
- 2) Carefully compare the packing slip(s) against the package contents to verify the receipt of all expected items.
- 3) Retain all product documentation and make sure that manuals are forwarded to the appropriate site management, installation and service personnel.

Lightning Protection

Although relatively rugged, lightning can damage the internal working mechanisms inside the BDA. We recommend the installation of a lightning surge suppressor in the transmission line where it enters the building prior to the BDA. The suppressor should be grounded to the building ground buss at the transmission line entry point. Choose a suppressor that will handle the expected amount of input power from the BDA to the donor antenna.

Antenna Installation

Buildings that are not designed or upgraded for antenna systems need special attention for antenna mountings, equipment installation and Cable runs. There are many variables involved in the design of a DAS system (distributed antenna system).

-Structural requirements for the location of the outdoor antenna (Donor); masts towers, building structure for the wind and ice loading.

-Protection of antennas and cables from building occupants and general human interaction.

- Installers/designers must be aware of general seating, foot traffic areas and different access points.
- All Antennas must be designed for the working frequency, which ensure meeting the exposure requirements.

- The donor antenna and distribution antennas must be have 12 dB + the Maximum gain of the amplifier of isolation between them. Less isolation will cause the module to overload and oscillation will occur which may result in damage to the amplification module.

- Antennas should be mounted following the manufactures' guidelines for RF connection and being affixed to the building or location of desired signal.

- All cables used in the DAS system shall be 50 ohms and clamped properly to ensure the cables 50 ohm impedance characteristics. Improper clamps will change the impedance of the cable at that location thus changing the efficiency of the system.

- Antenna placement through the DAS system is important to impose a balanced distributed signal. The use of proper valued (dB) decouples, power dividers, and signal taps is important to promote a balanced system.

BDA INSTALLATION

DO NOT APPLY A.C. POWER TO THE BDA UNTIL CABLES ARE CONNECTED TO BOTH PORTS OF THE BDA AND THE ANTENNAS.

1. Mount the BDA on the wall with the RF connectors pointing DOWN. Using appropriate screws and anchors, attach the BDA to the wall at the four mounting holes on the side flanges.
2. Ensure that the isolation between the donor antenna and the service antenna is at least 12 dB greater than the BDA gain. (Use the higher of the Uplink and Downlink gains reported on the BDA test data sheet).
3. Connect the cable from the donor antenna to the BDA connector labeled “BASE” and the cable from the service antennas to the BDA connector labeled “MOBILE”.
4. Open the door of the metallic box of the BDA and verify that both of the PSU switches are in their factory preset “ON” positions. Close the panels.
5. Connect the AC power cord to the BDA and then to the power source. Verify that the “Power ON” lamp is illuminated.
6. Connect the computer with the software v1.02 installed via RS 232 connector or via a USB port.
7. on RF_BDA_GUI make sure that AGC Anable, ASD Enable and HPA Enable fuctions are turned ON.

Installation of the BDA is now complete. To adjust the gain controls to suit the specific signal environment, refer to the section monitoring and Control.



Figure 4: 700 MHz Bidirectional Amplifier



Figure 5: Label position on the BDA

The amplifier unit has its FCC/IC, Warning and Signal Booster Class B labels on the front cover, as shown in the above picture. These labels must not be removed.

If the amplifiers units are installed in a host device where this label is not visible, the host device should have visible label with the following text:

BDA764806: Contains FCC ID: WDM-BDA764806
Model: BDA764806
IC: 7755A-BDA764806
HVIN: BDA764806 FVIN: BDA RF GUI V1.02



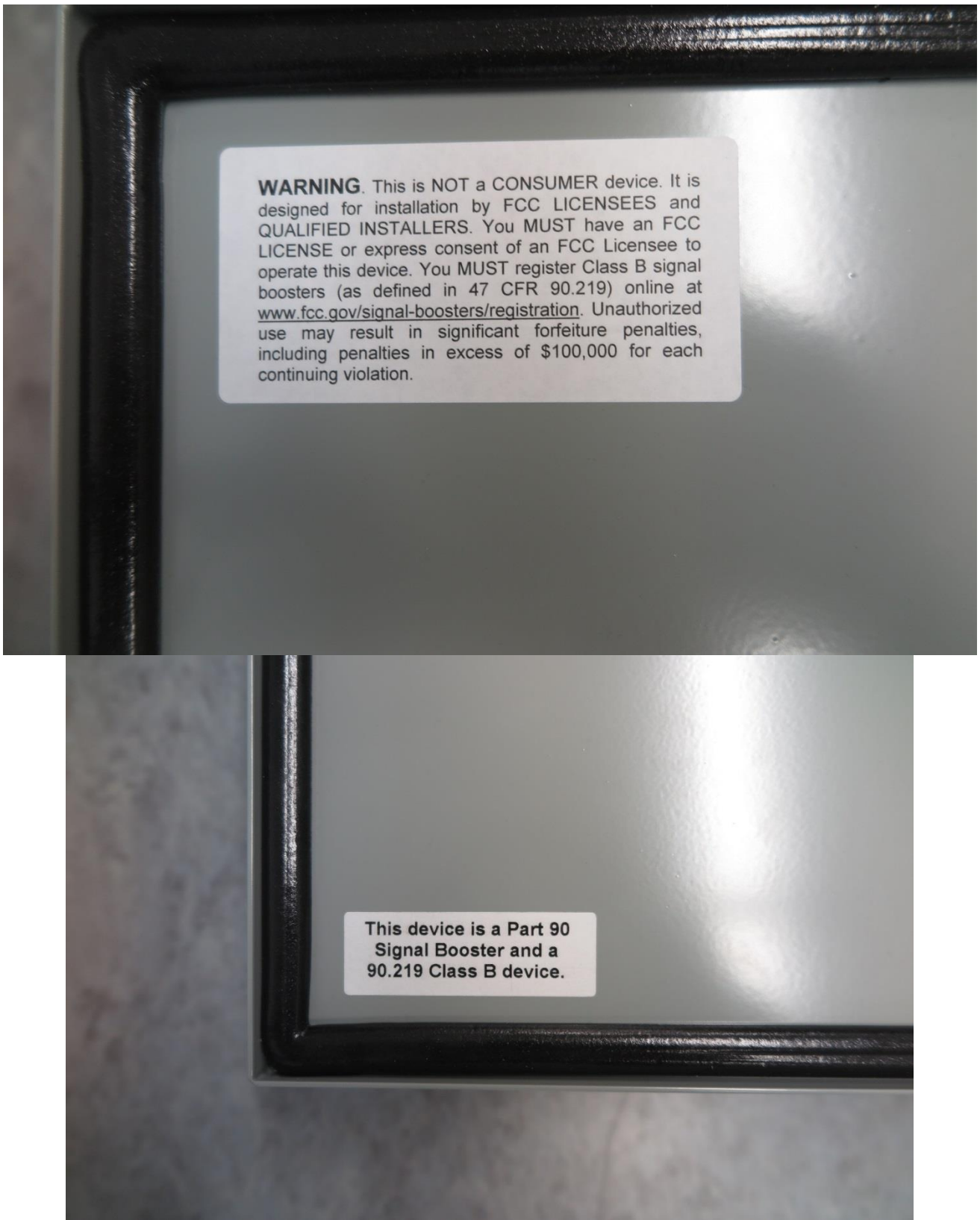



Figure 6: Labels on BDA.

Warnings and Notices

WARNING: Changes or modifications not expressly approved by Comprod Communications could void the user's authority to operate the equipment

 **WARNING:** *To satisfy RF exposure requirement*

FCC: The RF exposure safe separation distance is 20cm

IC: The RF exposure safe separation distance is 21.42cm

Notice:

This equipment has been tested and found to comply with the limits for a Class A digital device, pursuant to Part 15 of the FCC Rules. These limits are designed to provide reasonable protection against harmful interference when the equipment is operated in a commercial environment. This equipment generates, uses, and can radiate radio frequency energy and, if not installed and used in accordance with the instruction manual, may cause harmful interference to radio communications. Operation of this equipment in a residential area is likely to cause harmful interference in which case the user will be required to correct the interference at his own expense.

End of Document