



NVLAP LAB CODE 200707-0



# FCC PART 15.247

## MEASUREMENT AND TEST REPORT

For

### Shenzhen TOKWA Precision Technology Co., Ltd.

3F, Building A, 1 Block, Hongpai Technology Garden, Tianfu Road,  
Fuyong Town, Baoan District, Shenzhen, China.

**FCC ID: WDDKSC105B**

<b>This Report Concerns:</b> <input checked="" type="checkbox"/> Original Report	<b>Equipment Type:</b> CAR CD/MP3 Player
<b>Test Engineer:</b> Chris Peng <i>Chris Peng</i>	
<b>Report No.:</b> RSZ08060205	
<b>Test Date:</b> 2008-08-01 to 2008-08-20	
<b>Report Date:</b> 2008-08-21	
<b>Reviewed By:</b> EMC Manager: Green Xu <i>Green Xu</i>	
<b>Prepared By:</b> Bay Area Compliance Laboratories Corp. (Shenzhen) 6/F, the 3rd Phase of WanLi Industrial Building, ShiHua Road, FuTian Free Trade Zone Shenzhen, Guangdong, China Tel: +86-755-33320018 Fax: +86-755-33320008	

**Note:** This test report is for the customer shown above and their specific product only. It may not be duplicated or used in part without prior written consent from Bay Area Compliance Laboratories Corp. (Shenzhen) This report **must not** be used by the customer to claim product certification, approval, or endorsement by NVLAP, NIST, or any agency of the Federal Government.

## TABLE OF CONTENTS

<b>GENERAL INFORMATION.....</b>	<b>4</b>
PRODUCT DESCRIPTION FOR EQUIPMENT UNDER TEST (EUT) .....	4
OBJECTIVE .....	4
RELATED SUBMITTAL(S)/GRANT(S).....	4
TEST METHODOLOGY .....	4
TEST FACILITY .....	4
<b>SYSTEM TEST CONFIGURATION.....</b>	<b>6</b>
DESCRIPTION OF TEST CONFIGURATION .....	6
EUT EXERCISE SOFTWARE .....	6
SPECIAL ACCESSORIES.....	6
EQUIPMENT MODIFICATIONS .....	6
HOST SYSTEM CONFIGURATION LIST AND DETAILS .....	6
LOCAL SUPPORT EQUIPMENT LIST AND DETAILS .....	6
EXTERNAL I/O CABLE.....	7
CONFIGURATION OF TEST SETUP .....	7
BLOCK DIAGRAM OF TEST SETUP .....	8
<b>SUMMARY OF TEST RESULTS .....</b>	<b>9</b>
<b>CFR47 §15.203 - ANTENNA REQUIREMENT.....</b>	<b>10</b>
STANDARD APPLICABLE .....	10
ANTENNA CONNECTOR CONSTRUCTION .....	10
<b>§15.247 (i) and §1.1307 (b) (1) - MAXIMUM PERMISSIBLE EXPOSURE (MPE) .....</b>	<b>11</b>
STANDARD APPLICABLE .....	11
TEST DATA .....	11
<b>CFR47 §15.205, §15.209, §15.247 - RADIATED EMISSIONS.....</b>	<b>12</b>
APPLICABLE STANDARD .....	12
MEASUREMENT UNCERTAINTY .....	12
EUT SETUP .....	12
EMI TEST RECEIVER & SPECTRUM ANALYZER SETUP .....	13
TEST EQUIPMENT LIST AND DETAILS.....	13
TEST PROCEDURE .....	13
CORRECTED AMPLITUDE & MARGIN CALCULATION .....	13
TEST RESULTS SUMMARY.....	14
TEST DATA .....	14
<b>CFR47 §15.247(a) (1)-CHANNEL SEPARATION TEST .....</b>	<b>18</b>
APPLICABLE STANDARD .....	18
TEST EQUIPMENT LIST AND DETAILS.....	18
TEST PROCEDURE .....	18
TEST DATA .....	18
<b>CFR47 §15.247(a) (1) –20dB BANDWIDTH TESTING .....</b>	<b>23</b>
APPLICABLE STANDARD .....	23

TEST EQUIPMENT LIST AND DETAILS.....23  
TEST PROCEDURE .....23  
TEST DATA .....23

**CFR47 §15.247(a) (1) (iii)-QUANTITY OF HOPPING CHANNEL TEST .....27**  
APPLICABLE STANDARD .....27  
TEST EQUIPMENT LIST AND DETAILS.....27  
TEST PROCEDURE .....27  
TEST DATA .....27

**CFR47 §15.247(a) (1) (iii) -TIME OF OCCUPANCY (DWELL TIME).....29**  
APPLICABLE STANDARD .....29  
TEST EQUIPMENT LIST AND DETAILS.....29  
TEST PROCEDURE .....29  
TEST DATA .....29

**CFR47 §15.247(b) (1) - PEAK OUTPUT POWER MEASUREMENT .....39**  
APPLICABLE STANDARD .....39  
TEST EQUIPMENT LIST AND DETAILS.....39  
TEST PROCEDURE .....39  
TEST DATA .....40

**CFR47 §15.247(d) - BAND EDGES TESTING .....44**  
APPLICABLE STANDARD .....44  
TEST EQUIPMENT LIST AND DETAILS.....44  
TEST PROCEDURE .....44  
TEST DATA .....45

---

## GENERAL INFORMATION

---

### Product Description for Equipment under Test (EUT)

The *Shenzhen TOKWA Precision Technology Co., Ltd.*'s product, model number: *KSC105B* or the "EUT" as referred to in this report is a *CAR CD/MP3 PLAYER*, which measures approximately: 20.0 cm L x 7.5 cm W x 5.0 cm H, rated input voltage: DC 12V battery.

\*Note: The series products, model KSC105B, KSC-105, VR500CSBT, we select KSC105B to test, the all model have same circuit diagram, PCB, only appearance have difference, which was explained in the attached Declaration Letter.

\* *All measurement and test data in this report was gathered from production sample serial number: 0806004 (Assigned by BAEL, Shenzhen). The EUT was received on 2008-06-02.*

### Objective

This Type approval report is prepared on behalf of *Shenzhen TOKWA Precision Technology Co., Ltd.* in accordance with Part 2, Subpart J, Part 15, Subparts A, B and C of the Federal Communication Commissions rules.

The tests were performed in order to determine compliance with FCC Part 15, Subpart C, and section 15.203, 15.205, 15.209 and 15.247 rules.

### Related Submittal(s)/Grant(s)

No related submittal(s).

### Test Methodology

All measurements contained in this report were conducted with ANSI C63.4-2003, American National Standard for Methods of Measurement of Radio-Noise Emissions from Low-Voltage Electrical and Electronic Equipment in the range of 9 kHz to 40 GHz.

All emissions measurement was performed and Bay Area Compliance Laboratories Corp. (Shenzhen). The radiated testing was performed at an antenna-to-EUT distance of 3 meters.

### Test Facility

The Test site used by Bay Area Compliance Laboratories Corp. (Shenzhen) to collect test data is located in the 6/F, the 3rd Phase of WanLi Industrial Building, ShiHua Road, FuTian Free Trade Zone Shenzhen, Guangdong, China.

Test site at Bay Area Compliance Laboratories Corp. (Shenzhen) has been fully described in reports submitted to the Federal Communication Commission (FCC). The details of these reports have been found to be in compliance with the requirements of Section 2.948 of the FCC Rules on November 04, 2004. The facility also complies with the radiated and AC line conducted test site criteria set forth in ANSI C63.4-2003.

The Federal Communications Commission has the reports on file and is listed under FCC Registration No.: 382179. The test site has been approved by the FCC for public use and is listed in the FCC Public Access Link (PAL) database.

Additionally, Bay Area Compliance Laboratories Corp. (Shenzhen) is a National Institute of Standards and Technology (NIST) accredited laboratory, under the National Voluntary Laboratory Accredited Program (Lab Code 200707-0).



NVLAP LAB CODE 200707-0

The current scope of accreditations can be found at  
<http://ts.nist.gov/Standards/scopes/2007070.htm>.

## SYSTEM TEST CONFIGURATION

### Description of Test Configuration

The system was configured for testing in a typical fashion (as normally used by a typical user).

### EUT Exercise Software

Bluetooth test.

### Special Accessories

The special accessories were provided by Bay Area Compliance Laboratories Corp. (Shenzhen).

### Equipment Modifications

No modification was made to the unit tested.

### Host System Configuration List and Details

Manufacturer	Description	Model	Serial Number	FCC ID
DELL	Motherboard	OWC297	CN-OWC297-70821-564-00NI	DoC
DELL	Power	NPS-250KB D	CN-0H2678-17972-56E-80BM	DoC
Seagate	Hard Disk	ST340014A	5JXK3GXE	DoC
DELL	3.5' Floppy	N/A	CN-0N8893-69802-54Q-02P0	DoC
Lite-ON	CD-Rom	LTN-489S	N/A	DoC
Intel	Ethernet	PRO 10/100 VE	N/A	DoC
ProMOS	Memory	V826632K24SATG-C0	0525-K1933700	N/A
Intel	CPU	Celeron D-2533	N/A	N/A

### Local Support Equipment List and Details

Manufacturer	Description	Model	Serial Number	FCC ID
DELL	PC	DELL 170L	CN-0TC670-70821-560-F4Q6	DoC
DELL	Keyboard	SK-8110	CN07N244-71616-56A-1B1E	DoC
DELL	Mouse	M071KC	520027907	DoC
DELL	LCD Monitor	1505FP	Y4287-7168-571-GBSH	DoC

## External I/O Cable

Cable Description	Length (M)	From/Port	To
Shielded Detachable K/B Cable	1.5	K/B Port/Host	K/B
Shielded Detachable Mouse Cable	1.5	Mouse Port/Host	Mouse
Shielded Detachable VGA Cable	1.5	VGA Port/Host	Monitor

## Configuration of Test Setup

For Radiated:

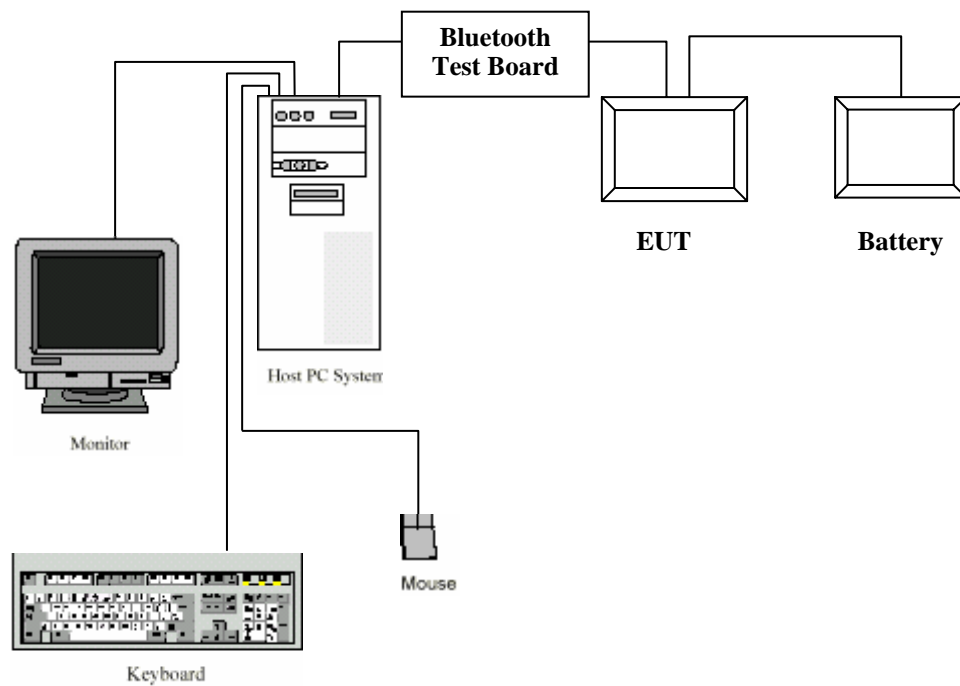

### Block Diagram of Test Setup

For Radiated:

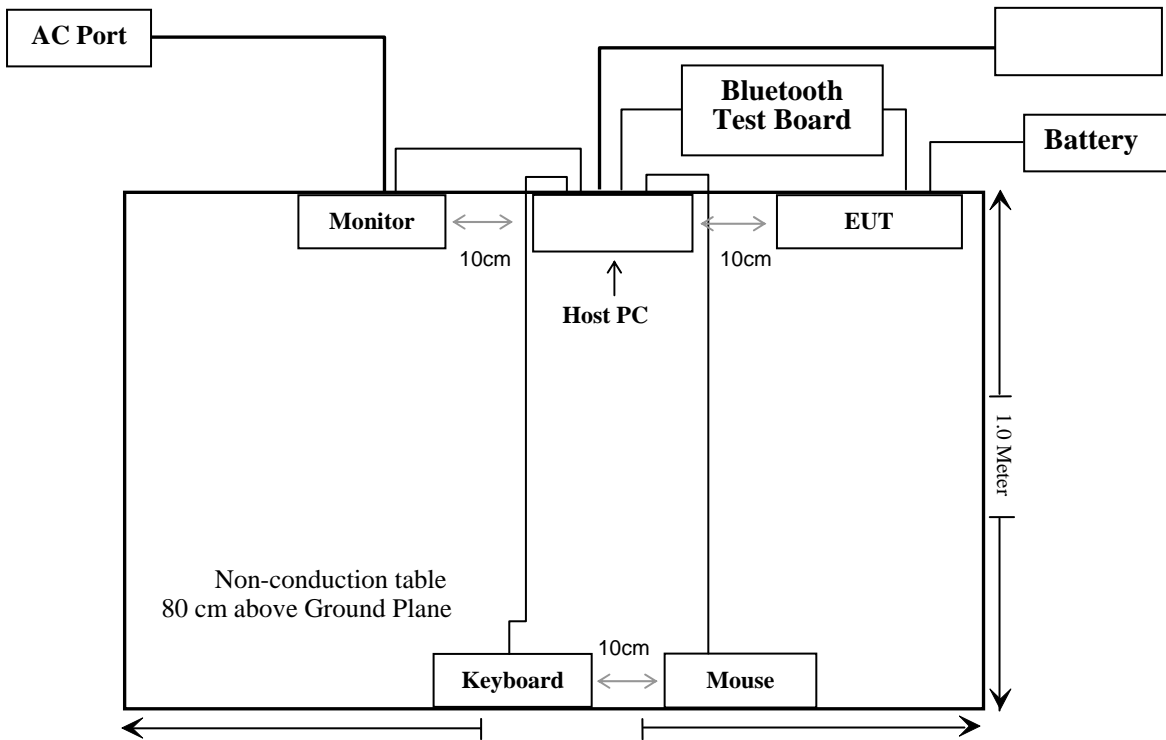



## SUMMARY OF TEST RESULTS

FCC Rules	Description of Test	Result
§15.247 (i), §1.1307 (b)(1)	Maximum Permissible Exposure (MPE)	Compliant
CFR47 §15.203	Antenna Requirement	Compliant
CFR47 §15.207 (a)	Conducted Emissions	N/A*
CFR47 §15.205	Restricted Band	Compliant
CFR47 §15.205, §15.209, §15.247(d)	Radiated Emission	Compliant
CFR47 §15.247 (a)(1)	20 dB Bandwidth	Compliant
CFR47 §15.247(a)(1)	Channel Separation Test	Compliant
CFR47 §15.247(a)(1)(iii)	Time of occupancy (Dwell Time)	Compliant
CFR47 §15.247(a)(1)(iii)	Quantity of hopping channel Test	Compliant
CFR47 §15.247(b)(1)	Peak Output Power Measurement	Compliant
CFR47 §15.247(d)	Band edges	Compliant

\* Note: The EUT input voltage: DC 12V battery, so no need test conducted emissions.

---

## **CFR47 §15.203 - ANTENNA REQUIREMENT**

---

### **Standard Applicable**

According to CFR47 § 15.203, an intentional radiator shall be designed to ensure that no antenna other than that furnished by the responsible party shall be used with the device. The use of a permanently attached antenna or of an antenna that uses a unique coupling to the intentional radiator shall be considered sufficient to comply with the provisions of this Section. The manufacturer may design the unit so that a broken antenna can be replaced by the user, but the use of a standard antenna jack or electrical connector is prohibited.

### **Antenna Connector Construction**

The EUT antenna is a permanently attached antenna, which in accordance to section 15.203 is considered sufficient to comply with the provisions of this section.

**Result:** Compliance.

Please refer to the EUT internal photos.

## §15.247 (i) and §1.1307 (b) (1) - MAXIMUM PERMISSIBLE EXPOSURE (MPE)

### Standard Applicable

According to subpart 15.247 (i) and subpart 1.1307 (b)(1), systems operating under the provisions of this section shall be operated in a manner that ensures the public is not exposed to RF energy level in excess of the communication guidelines.

Limits for General Population/Uncontrolled Exposure

Limits for General Population/Uncontrolled Exposure				
Frequency Range (MHz)	Electric Field Strength (V/m)	Magnetic Field Strength (A/m)	Power Density (mW/cm <sup>2</sup> )	Averaging Time (minutes)
0.3-1.34	614	1.63	*(100)	30
1.34-30	824/f	2.19/f	*(180/f <sup>2</sup> )	30
30-300	27.5	0.073	0.2	30
300-1500	/	/	f/1500	30
1500-100,000	/	/	1.0	30

f = frequency in MHz

\* = Plane-wave equivalent power density

### Test Data

Predication of MPE limit at a given distance

$$S = PG/4\pi R^2$$

S = power density (in appropriate units, e.g. mW/cm<sup>2</sup>)

P = power input to the antenna (in appropriate units, e.g., mW)

G = power gain of the antenna in the direction of interest relative to an isotropic radiator, the power gain factor, is normally *numeric* gain.

R = distance to the center of radiation of the antenna (appropriate units, e.g., cm)

Maximum peak output power at antenna input terminal: 3.06 (dBm)

Maximum peak output power at antenna input terminal: 2.023 (mW)

Predication distance: >20 (cm)

Predication frequency: 2441(MHz)

Antenna Gain (typical): 2 (dBi)

Antenna Gain (typical): 1.585 numeric

The worst case is power density at predication frequency at 20 cm: 0.000638 (mW/cm<sup>2</sup>)

MPE limit for general population exposure at predication frequency: 1 (mW/cm<sup>2</sup>)

$$0.000638(\text{mW}/\text{cm}^2) < 1 (\text{mW}/\text{cm}^2)$$

**Result:** Compliant at 20 cm.

## CFR47 §15.205, §15.209, §15.247 - RADIATED EMISSIONS

### Applicable Standard

CFR47 §15.205; §15.209; §15.247 (d).

### Measurement Uncertainty

All measurements involve certain levels of uncertainties, especially in field of EMC. The factors contributing to uncertainties are spectrum analyzer, cable loss, antenna factor calibration, antenna directivity, antenna factor variation with height, antenna phase center variation, antenna factor frequency interpolation, measurement distance variation, site imperfections, mismatch (average), and system repeatability.

Based on NIS 81, The Treatment of Uncertainty in EMC Measurements, the best estimate of the uncertainty of a radiation emissions measurement at Bay Area Compliance Laboratories Corp. (Shenzhen) is  $\pm 4.0$  dB.

### EUT Setup

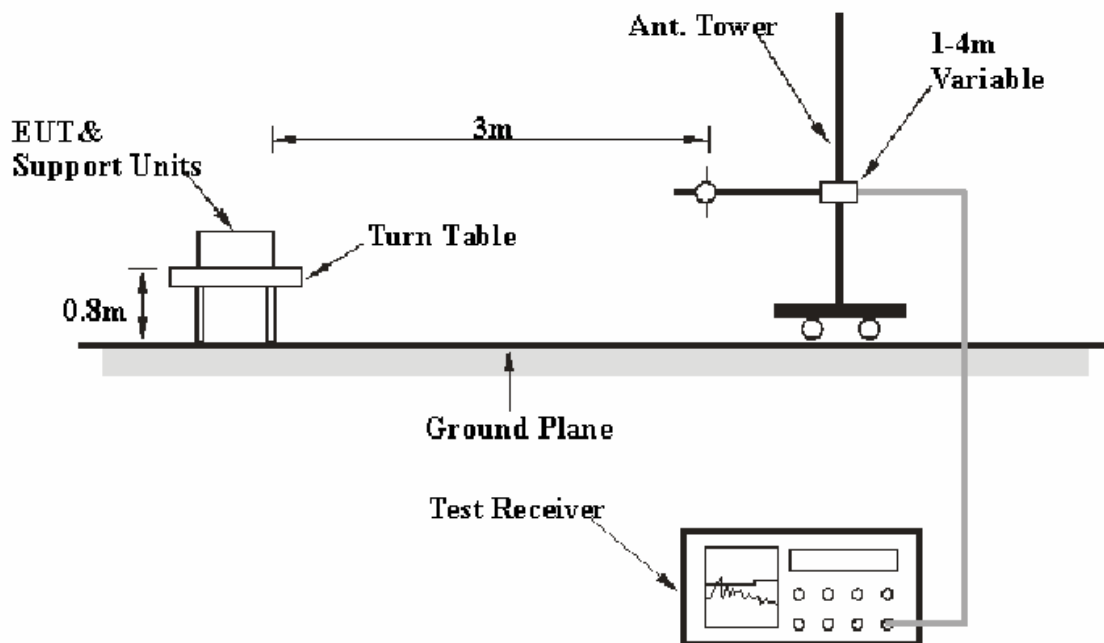

The radiated emission tests were performed in the 3 meters chamber B test site, using the setup accordance with the ANSI C63.4-2003. The specification used was the FCC 15.109, FCC 15.209 and FCC 15.247 limits.

The external I/O cables were draped along the test table and formed a bundle 30 to 40 cm long in the middle.

The spacing between the peripherals was 10 cm.

The host PC was connected to a 120 VAC/60 Hz power source.

## EMI Test Receiver & Spectrum Analyzer Setup

The system was investigated from 30 MHz to 25 GHz.

During the radiated emission test, the EMI test receiver & Spectrum Analyzer Setup were set with the following configurations:

<i>Frequency Range</i>	<i>RBW</i>	<i>Video B/W</i>
30MHz – 1000 MHz	100 kHz	300 kHz
1000 MHz – 25 GHz	1 MHz	3 MHz

## Test Equipment List and Details

Manufacturer	Description	Model	Serial Number	Calibration Date	Calibration Due Date
HP	Amplifier	HP8447D	2944A09795	2007-11-15	2008-11-15
Rohde & Schwarz	EMI Test Receiver	ESCI	100035	2007-10-16	2008-10-16
Sunol Sciences	Broadband Antenna	JB1	A040904-1	2007-08-14	2008-08-14
HP	Amplifier	8449B	3008A00277	2007-09-29	2008-09-29
Sunol Sciences	Horn Antenna	DRH-118	A052604	2007-09-25	2008-09-25
Rohde & Schwarz	Spectrum Analyzer	FSEM30	849720/019	2008-05-09	2009-05-09

\* **Statement of Traceability:** Bay Area Compliance Laboratories Corp. (Shenzhen) attests that all calibrations have been performed in accordance to NVLAP requirements, traceable to the NIST.

## Test Procedure

For the radiated emissions test, the host PC was connected to the AC floor outlet.

Maximizing procedure was performed on the highest emissions to ensure that the EUT complied with all installation combinations.

Data was recorded in Quasi-peak detection mode for frequency range of 30 MHz-1GHz and peak and Average detection modes for frequencies above 1GHz.

## Corrected Amplitude & Margin Calculation

The Corrected Amplitude is calculated by adding the Antenna Factor and Cable Loss, and subtracting the Amplifier Gain from the Meter Reading. The basic equation is as follows:

$$\text{Corrected Amplitude} = \text{Meter Reading} + \text{Antenna Factor} + \text{Cable Loss} - \text{Amplifier Gain}$$

The “**Margin**” column of the following data tables indicates the degree of compliance with the applicable limit. For example, a margin of 7dB means the emission is 7dB below the maximum limit. The equation for margin calculation is as follows:

$$\text{Margin} = \text{Limit} - \text{Corrected Amplitude}$$

## Test Results Summary

According to the recorded data in following table, the EUT complied with the FCC Title 47, Part 15, Subpart C, section 15.109, 15.205, 15.209, and 15.247, with the worst margin reading of:

Below 1GHz:

For Transmitting Mode: **7.60 dB** at **906.984875 MHz** in the **Horizontal** polarization

Above 1GHz:

**2.33 dB** at **4804 MHz** in the **Vertical** polarization, **for Low Channel**  
**2.97 dB** at **4882 MHz** in the **Vertical** polarization, **for Middle Channel**  
**2.49 dB** at **4960 MHz** in the **Vertical** polarization, **for High Channel**

## Test Data

### Environmental Conditions

<b>Temperature:</b>	25 ° C
<b>Relative Humidity:</b>	52%
<b>ATM Pressure:</b>	100.9 kPa

*The testing was performed by Chris Peng on 2008-08-01 to 2008-08-20.*

**Below 1GHz:**

Test Mode: Transmitting

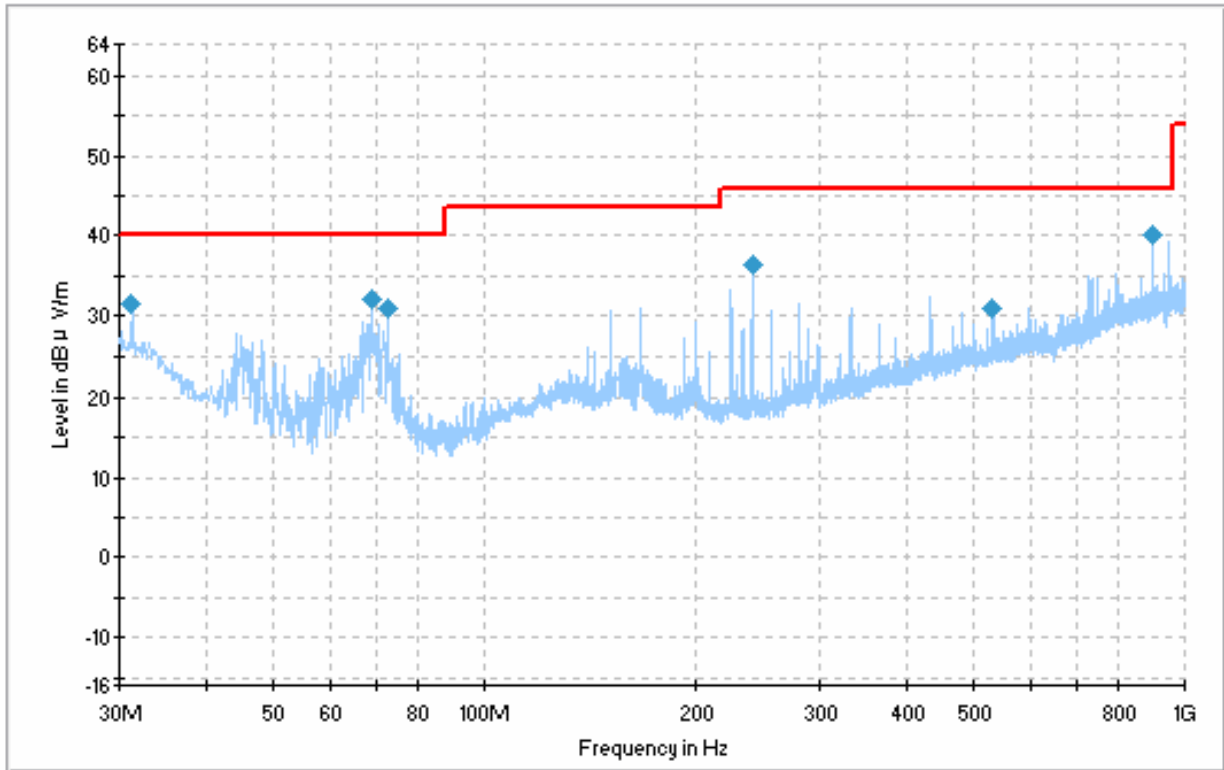

Frequency (MHz)	Corrected Amp. (dBμV/m)	Ant. Height (cm)	Ant. Polarity (H/V)	Turntable Position (deg)	Correction Factor (dB)	Limit (dBμV/m)	Margin (dB)
906.984875	38.4	139.0	H	305.0	0.0	46.0	7.6
68.826950	32.0	300.0	H	186.0	-22.2	40.0	8.0
31.047100	31.5	117.0	H	0.0	-9.3	40.0	8.5
240.010100	36.3	171.0	H	7.0	-17.1	46.0	9.7
72.594075	29.8	401.0	H	2.0	-22.2	40.0	10.2
531.243670	31.0	359.0	V	230.0	-0.3	46.0	15.0

**Above 1 GHz***Test Mode: Transmitting*

Freq. (MHz)	Meter Reading (dB $\mu$ V)	Detector PK/QP/AV	Table Direction Degree	Antenna			Cable Loss (dB)	Pre-Amp. Gain (dB)	Corr. Amp. (dB $\mu$ V/m)	FCC Part15.247/15.209		
				Height (m)	Polar (H/V)	Factor (dB/m)				Limit (dB $\mu$ V/m)	Margin (dB)	Remarks
<b>Low Channel 2402 MHz</b>												
2402	96.48	PK	90	1.0	H	30.6	3.61	35.0	97.27			Fund.
2402	89.37	AV	45	1.0	H	30.6	3.61	35.0	88.58			Fund.
2402	92.42	PK	90	1.0	V	30.6	3.61	35.0	91.63			Fund.
2402	89.79	AV	45	1.0	V	30.6	3.61	35.0	89.00			Fund.
4804	45.03	AV	90	1.0	V	35.4	4.64	33.4	51.67	54	2.33*	Harmonic
4804	41.18	AV	90	1.0	H	36.6	4.64	33.4	49.02	54	4.98	Harmonic
1601	49.92	AV	180	1.2	V	26.0	2.77	35.0	43.69	54	10.31	Spurious
1601	48.99	AV	180	1.2	H	26.5	2.77	35.0	43.26	54	10.74	Spurious
4804	50.96	PK	180	1.2	V	35.4	4.64	33.4	57.60	74	16.4	Harmonic
1601	62.92	PK	45	1.2	V	26.0	2.77	35.0	56.69	74	17.31	Spurious
4804	47.82	PK	180	1.2	H	36.6	4.64	33.4	55.66	74	18.34	Harmonic
1601	60.82	PK	45	1.2	H	26.5	2.77	35.0	55.09	74	18.91	Spurious
<b>Middle Channel 2441MHz</b>												
2441	91.04	PK	60	1.4	H	30.6	3.61	35.0	90.25			Fund.
2441	88.30	AV	152	1.3	H	30.6	3.61	35.0	87.51			Fund.
2441	91.30	PK	128	1.5	V	30.6	3.61	35.0	90.51			Fund.
2441	90.19	AV	156	1.2	V	30.6	3.61	35.0	89.4			Fund.
4882	44.39	AV	243	1.4	V	35.4	4.64	33.4	51.03	54	2.97*	Harmonic
4882	41.96	AV	142	1.6	H	36.6	4.64	33.4	49.80	54	4.20	Harmonic
1627.8	49.24	AV	85	1.5	V	26.0	2.77	35.0	43.01	54	10.99	Spurious
4882	55.29	PK	153	1.5	V	35.4	4.64	33.4	61.93	74	12.07	Harmonic
1627.8	46.37	AV	135	1.3	H	26.5	2.77	36.0	39.64	54	14.36	Spurious
1627.8	63.05	PK	265	1.4	V	26.0	2.77	35.0	56.82	74	17.18	Spurious
4882	47.84	PK	234	1.8	H	36.6	4.64	33.4	55.68	74	18.32	Harmonic
1627.8	61.95	PK	156	1.4	H	26.5	2.77	36.0	55.22	74	18.78	Spurious
<b>High Channel 2480 MHz</b>												
2480	91.84	PK	89	1.5	H	30.6	3.61	35.0	91.05			Fund.
2480	88.62	AV	65	1.5	H	30.6	3.61	35.0	87.83			Fund.
2480	92.56	PK	65	1.4	V	30.6	3.61	35.0	91.77			Fund.
2480	90.89	AV	65	1.6	V	30.6	3.61	35.0	90.10			Fund.
4960	44.96	AV	142	1.5	V	35.4	4.55	33.4	51.51	54	2.49*	Harmonic
4960	41.93	AV	256	1.8	H	36.6	4.55	33.4	49.68	54	4.32	Harmonic
1653.9	50.62	AV	210	1.2	V	26.0	2.77	35.0	44.39	54	9.61	Spurious
1653.9	48.99	AV	156	1.2	H	26.5	2.77	35.0	43.26	54	10.74	Spurious
4960	54.75	PK	142	1.4	V	35.4	4.55	33.4	61.3	74	12.7	Harmonic
1653.9	64.57	PK	240	1.4	V	26.0	2.77	35.0	58.34	74	15.66	Spurious
4960	48.99	PK	145	1.4	H	36.6	4.55	33.4	56.74	74	17.26	Harmonic
1653.9	62.00	PK	128	1.5	H	26.5	2.77	35.0	56.27	74	17.73	Spurious

\* Within measurement uncertainty.



Restrict Band:

Freq. (MHz)	Meter Reading (dB $\mu$ V)	Detector PK/QP/AV	Table Direction Degree	Antenna			Cable Loss (dB)	Pre- Amp. Gain (dB)	Corr. Amp. (dB $\mu$ V/m)	FCC Part15.247/15.209		
				Height (m)	Polar (H/V)	Factor (dB/m)				Limit (dB $\mu$ V/m)	Margin (dB)	Remarks
2483.96	42.74	AV	230	1.8	V	30.6	3.61	35.0	41.95	54	12.05	/
2483.96	48.15	PK	230	1.8	V	30.6	3.61	35.0	47.36	74	26.64	/

## CFR47 §15.247(a) (1)-CHANNEL SEPARATION TEST

### Applicable Standard

Frequency hopping systems shall have hopping channel carrier frequencies separated by a minimum of 25 kHz or the 20dB bandwidth of the hopping channel, whichever is greater. Alternatively, frequency hopping systems operating in the 2400-2483.5 MHz band may have hopping channel carrier frequencies that are separated by 25 kHz or two-thirds of the 20dB bandwidth of the hopping channel, whichever is greater provided the systems operate with an output power no greater than 125 mW.

### Test Equipment List and Details

Manufacturer	Description	Model	Serial Number	Calibration Date	Calibration Due Date
Rohde & Schwarz	EMI Test Receiver	ESCI	100035	2007-10-16	2008-10-16

\* **Statement of Traceability:** Bay Area Compliance Laboratories Corp. (Shenzhen) attests that all calibrations have been performed in accordance to NVLAP requirements, traceable to the NIST.

### Test Procedure

1. Set the EUT in transmitting mode, spectrum Bandwidth was set at 100 kHz, maxhold the channel.
2. Set the adjacent channel of the EUT maxhold another truce
3. Measure the channel separation.

### Test Data

#### Environmental Conditions

<b>Temperature:</b>	27 °C
<b>Relative Humidity:</b>	50 %
<b>ATM Pressure:</b>	100.9 kPa

*The testing was performed by Chris Peng on 2008-08-01.*

*Test Mode: Transmitting*

Channel	Channel Frequency (MHz)	Channel Separation (MHz)	Limit (MHz)	Result
Low Channel	2402	1.000	0.541	Pass
Adjacency Channel	2403			
Middle Channel	2441	1.004	0.536	Pass
Adjacency Channel	2442			
High Channel	2480	1.008	0.536	Pass
Adjacency Channel	2479			

**Test Result:** Compliance.

Please refer to following plots

### Low Channel

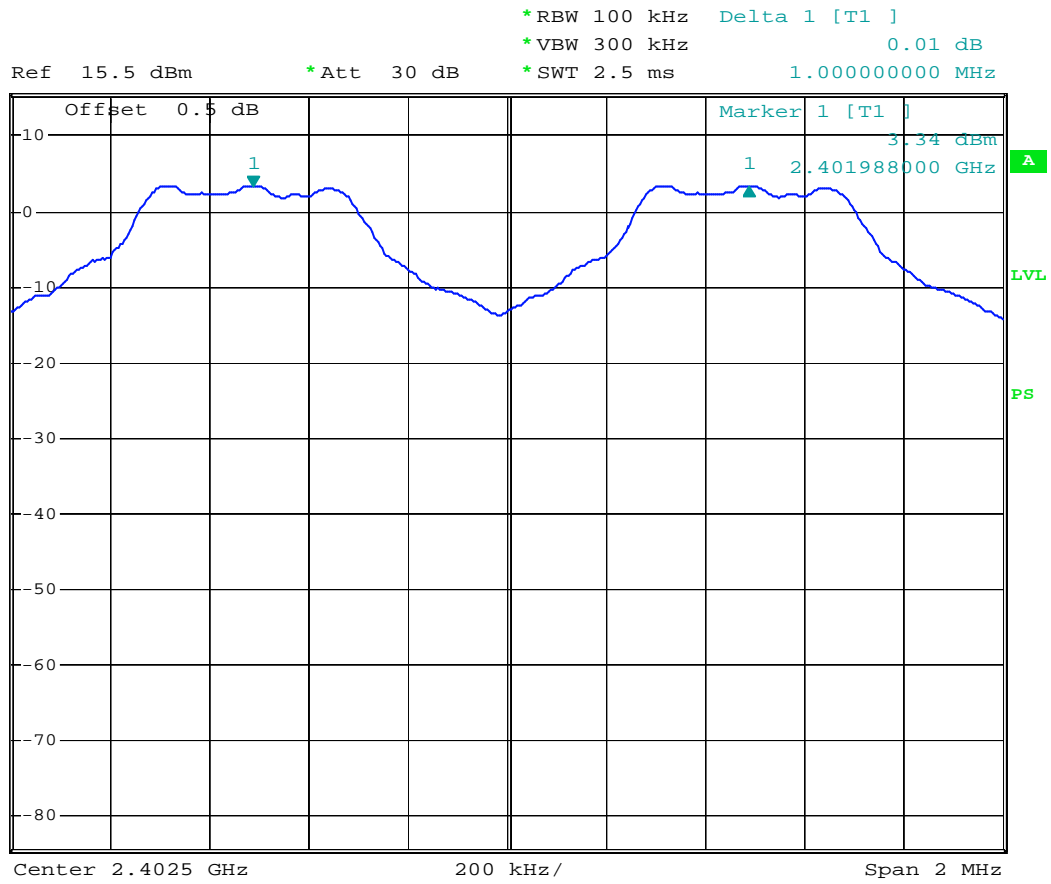

TOKWA channel separation low channel

Date: 1.AUG.2008 22:38:47



### High Channel

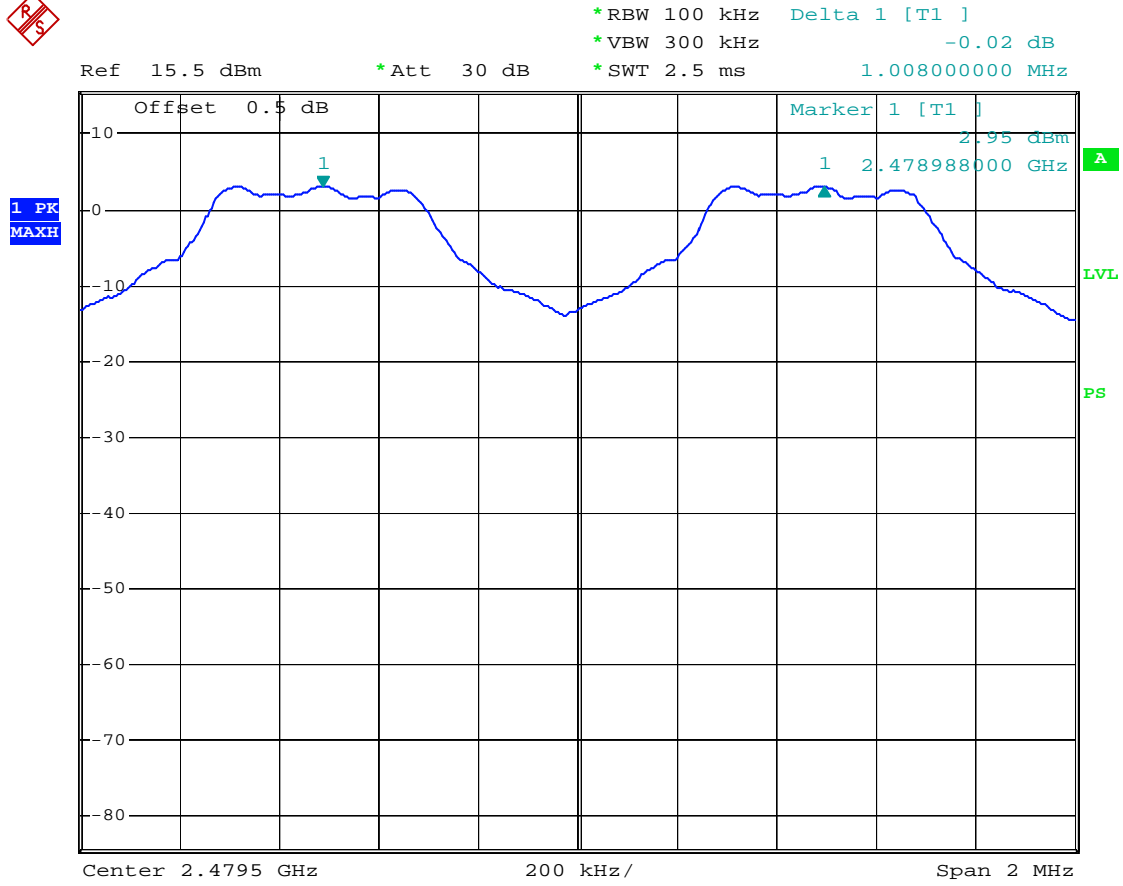

TOKWA channel separation high channel

Date: 1.AUG.2008 22:43:50

## CFR47 §15.247(a) (1) –20dB BANDWIDTH TESTING

### Applicable Standard

Alternatively, frequency hopping systems operating in the 2400–2483.5 MHz band may have hopping channel carrier frequencies that are separated by 25 kHz or two-thirds of the 20 dB bandwidth of the hopping channel, whichever is greater, provided the systems operate with an output power no greater than 125mW.

### Test Equipment List and Details

Manufacturer	Description	Model	Serial Number	Calibration Date	Calibration Due Date
Rohde & Schwarz	EMI Test Receiver	ESCI	100035	2007-10-16	2008-10-16

\* **Statement of Traceability:** Bay Area Compliance Laboratories Corp. (Shenzhen) attests that all calibrations have been performed in accordance to NVLAP requirements, traceable to the NIST.

### Test Procedure

1. Check the calibration of the measuring instrument using either an internal calibrator or a known signal from an external generator.
2. Position the EUT without connection to measurement instrument. Turn on the EUT and connect it to measurement instrument. Then set it to any one convenient frequency within its operating range. Set a reference level on the measuring instrument equal to the highest peak value.
3. Measure the frequency difference of two frequencies that were attenuated 20 dB from the reference level. Record the frequency difference as the emission bandwidth.
4. Repeat above procedures until all frequencies measured were complete.

### Test Data

#### Environmental Conditions

<b>Temperature:</b>	27 °C
<b>Relative Humidity:</b>	50 %
<b>ATM Pressure:</b>	100.9 kPa

*The testing was performed by Chris Peng on 2008-08-01.*

**Test Result:** Please refer to the following table and plots.

Channel	Channel Frequency (MHz)	20dB Bandwidth (kHz)
Low	2402	812
Middle	2441	804
High	2480	804

Low Channel

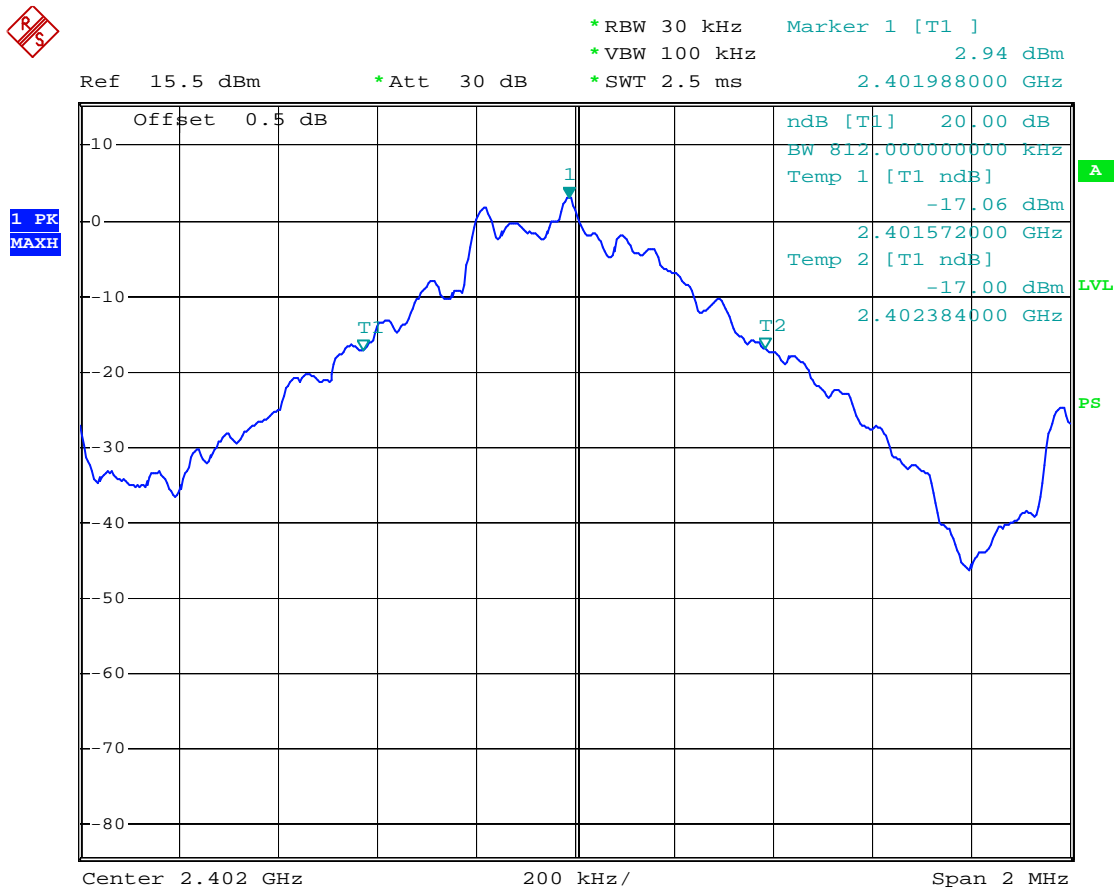

TOKWA low channel 20DB Bandwidth

Date: 1.AUG.2008 22:24:40



### Middle Channel

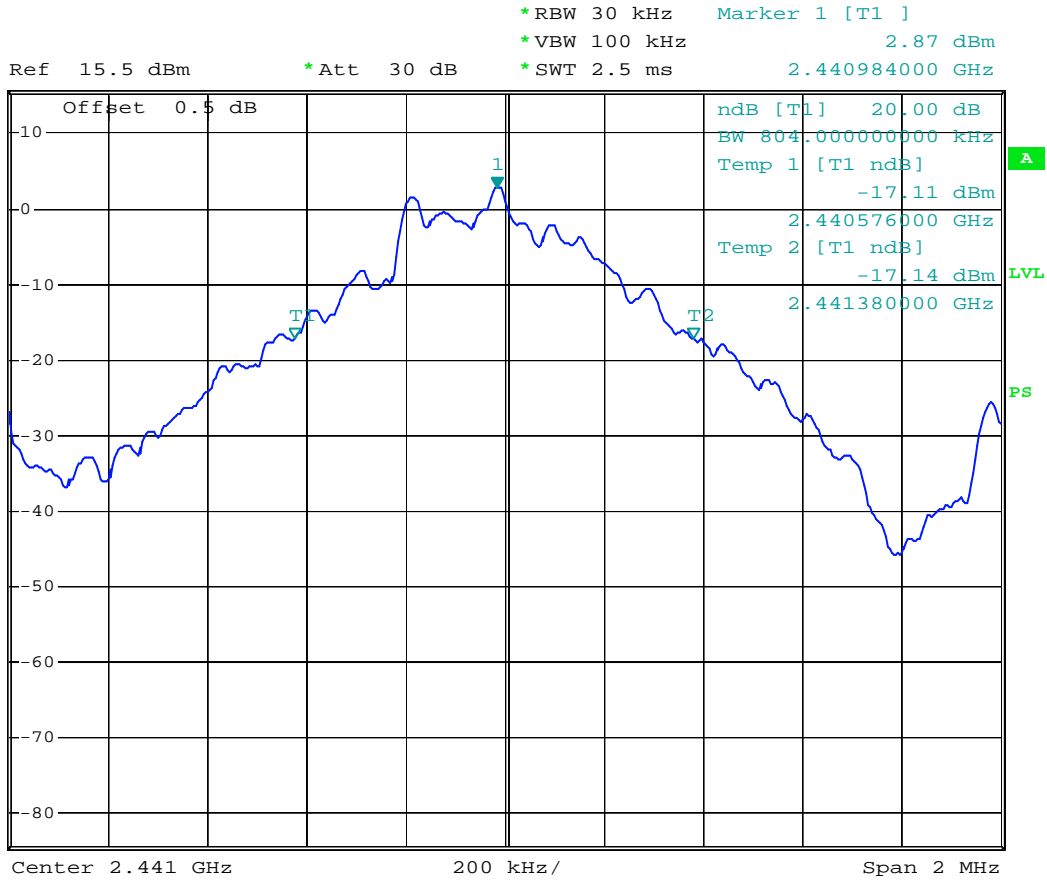

TOKWA middle channel 20DB Bandwidth

Date: 1.AUG.2008 22:25:56

### High Channel



1 PK  
MAXH

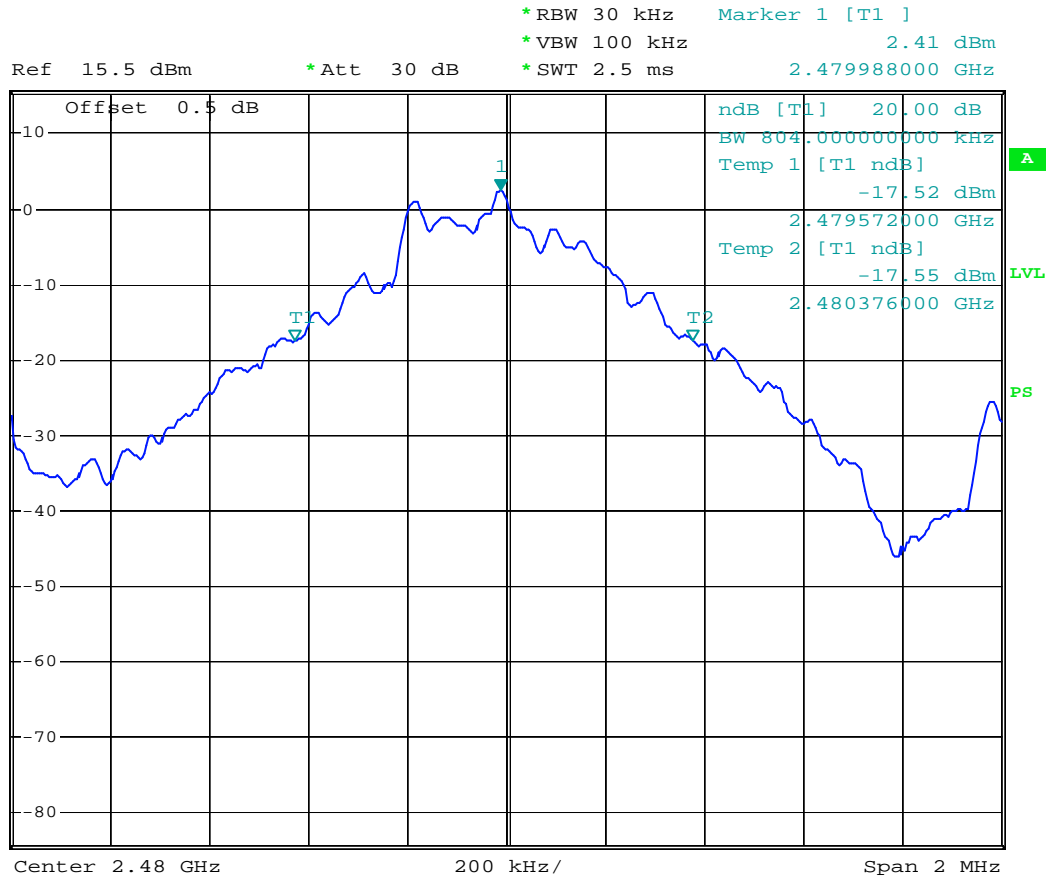

TOKWA high channel 20DB Bandwidth

Date: 1.AUG.2008 22:26:53

## CFR47 §15.247(a) (1) (iii)-QUANTITY OF HOPPING CHANNEL TEST

### Applicable Standard

Frequency hopping systems in the 2400–2483.5 MHz band shall use at least 15 channels. The average time of occupancy on any channel shall not be greater than 0.4 seconds within a period of 0.4 seconds multiplied by the number of hopping channels employed. Frequency hopping systems may avoid or suppress transmissions on a particular hopping frequency provided that a minimum of 15 channels are used.

### Test Equipment List and Details

Manufacturer	Description	Model	Serial Number	Calibration Date	Calibration Due Date
Rohde & Schwarz	EMI Test Receiver	ESCI	100035	2007-10-16	2008-10-16

\* **Statement of Traceability:** Bay Area Compliance Laboratories Corp. (Shenzhen) attests that all calibrations have been performed in accordance to NVLAP requirements, traceable to the NIST.

### Test Procedure

1. Check the calibration of the measuring instrument (SA) using either an internal calibrator or a known signal from an external generator.
2. Set the EUT in transmitting mode from first channel to last.
3. By using the Max-Hold function record the Quantity of the channel.

### Test Data

#### Environmental Conditions

<b>Temperature:</b>	27 °C
<b>Relative Humidity:</b>	50 %
<b>ATM Pressure:</b>	100.9 kPa

*The testing was performed by Chris Peng on 2008-08-01.*

*Test Mode: Transmitting*

Frequency Range (MHz)	Quantity of Hopping Channel (CH)	Limit (CH)
2402-2480	79	>15

**Test Result:** Compliance.

Please refer to following plot.

### Number of Hopping Channels



Ref 15.5 dBm      \*Att 30 dB      \*RBW 100 kHz      Delta 1 [T1 ]  
\*VBW 300 kHz      -0.41 dB  
\*SWT 10 ms      78.323000000 MHz

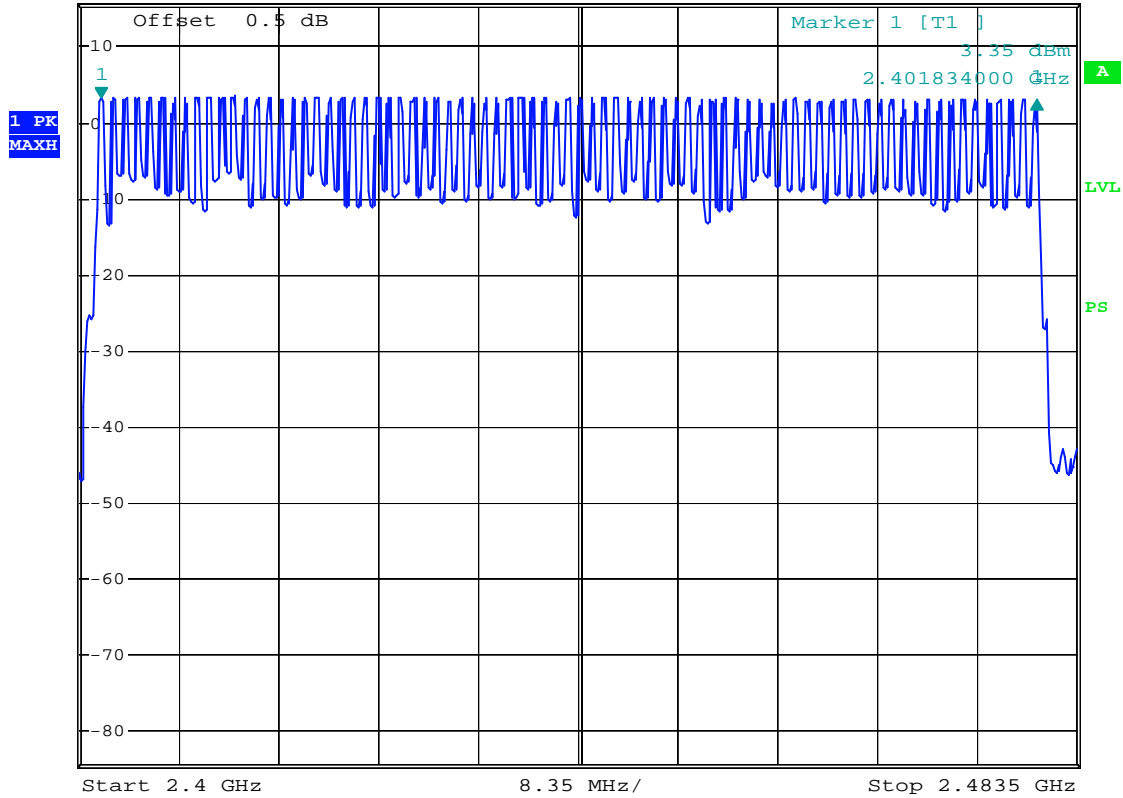

TOKWA channel quantity

Date: 1.AUG.2008 23:27:49

**CFR47 §15.247(a) (1) (iii) -TIME OF OCCUPANCY (DWELL TIME)****Applicable Standard**

Frequency hopping systems in the 2400-2483.5 MHz shall use at least 15 channels. The average time of occupancy on any channel shall not be greater than 0.4 seconds within a period of 0.4 seconds multiplied by the number of hopping channels employed. Frequency hopping systems may avoid or suppress transmissions on a particular hopping frequency provided that a minimum of 15 channels are used.

**Test Equipment List and Details**

Manufacturer	Description	Model	Serial Number	Calibration Date	Calibration Due Date
Rohde & Schwarz	EMI Test Receiver	ESCI	100035	2007-10-16	2008-10-16

\* **Statement of Traceability:** Bay Area Compliance Laboratories Corp. (Shenzhen) attests that all calibrations have been performed in accordance to NVLAP requirements, traceable to the NIST.

**Test Procedure**

The EUT was worked in channel hopping; Spectrum SPAN was set as 0. Sweep was set as 0.4 X channel no. (s), the quantity of pulse was get from single sweep. In addition, the time of single pulses was tested.

Dwell Time= time slot length \* hope rate/ number of hopping channels \* 31.6s  
Hop rate=1600/s

**Test Data****Environmental Conditions**

<b>Temperature:</b>	27 °C
<b>Relative Humidity:</b>	50 %
<b>ATM Pressure:</b>	100.9 kPa

*The testing was performed by Chris Peng on 2008-08-02.*

*Test Mode: Transmitting*

**Test Result:** Compliance.

Please refer to following tables and plots

**DH1**

Channel	Pulse width (msec)	Dwell time (sec)	Limit (sec)	Result
Low	0.540	0.1728	0.4	Pass
Middle	0.536	0.1715	0.4	Pass
High	0.536	0.1715	0.4	Pass

*NOTE: Pulse time\*(1600/2/79)\*31.6S*

**Low Channel**

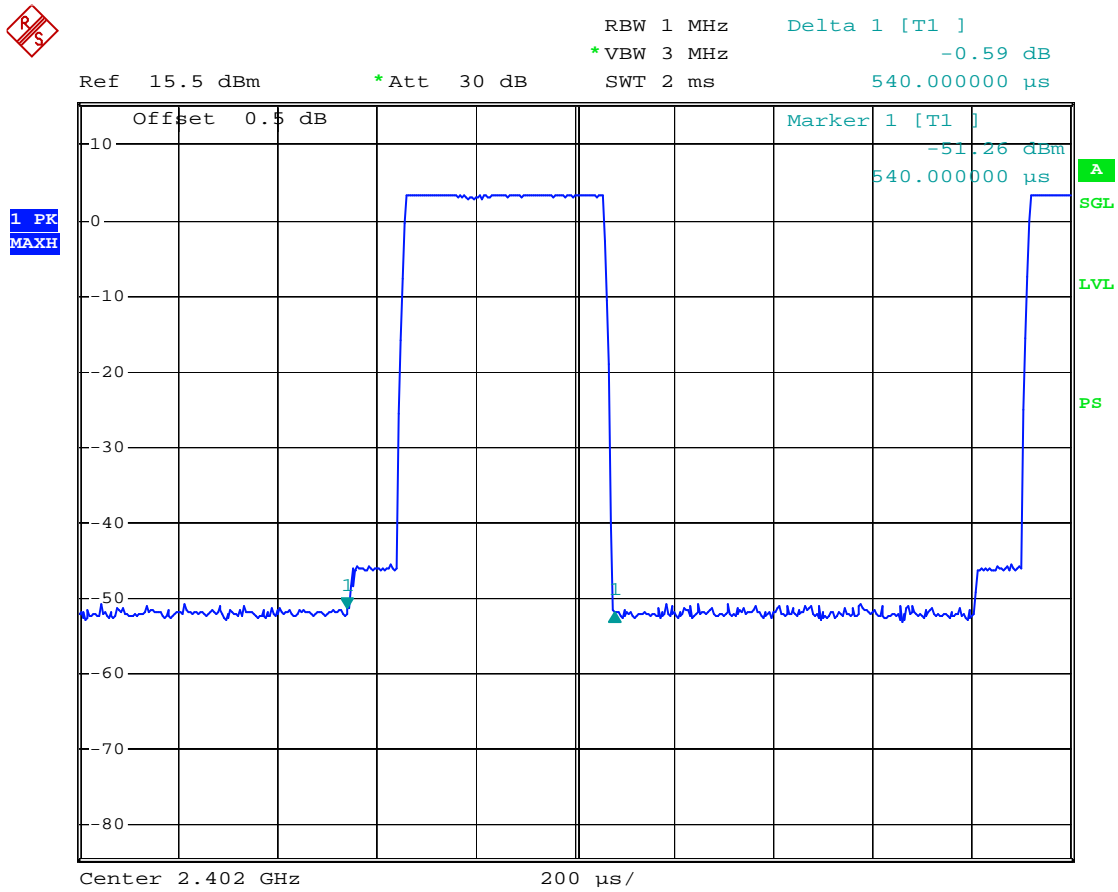

TOKWA Dwell time low channel dh1

Date: 2.AUG.2008 11:37:48

### Middle Channel

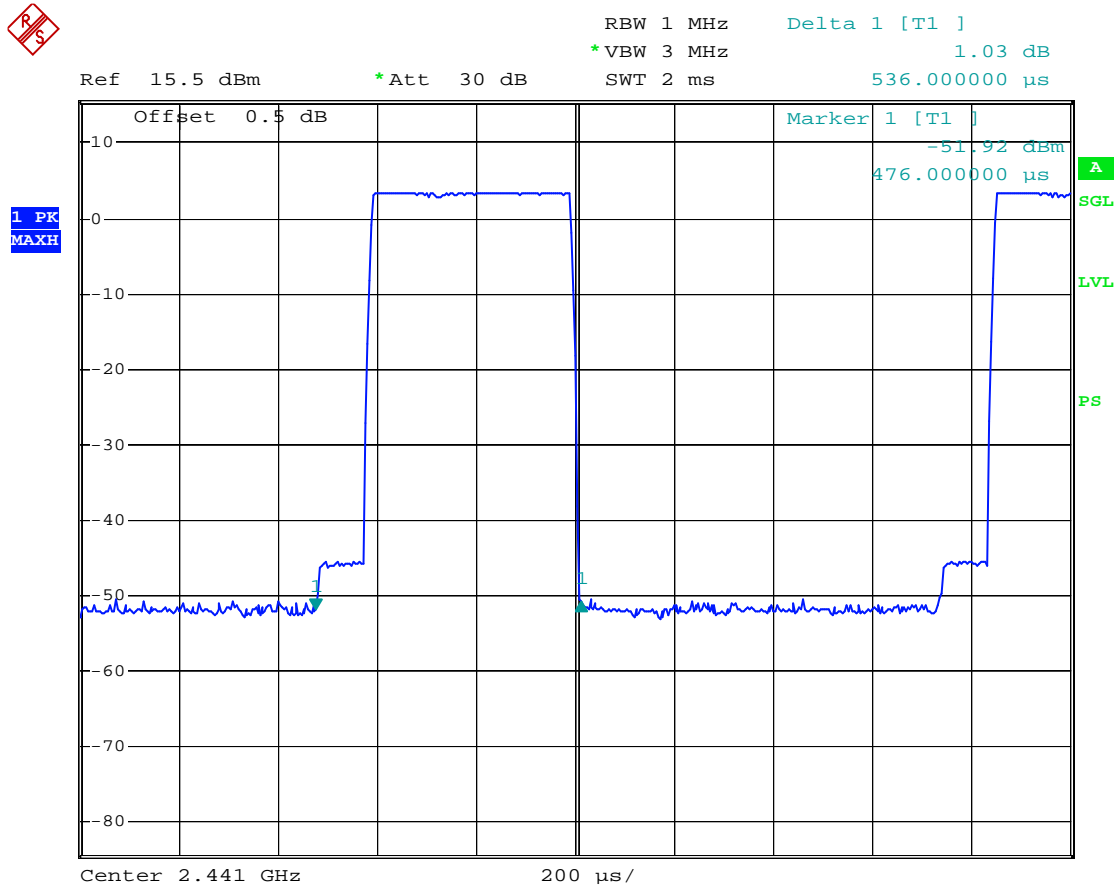

TOKWA Dwell time middle channel dh1

Date: 2.AUG.2008 12:18:27

### High Channel

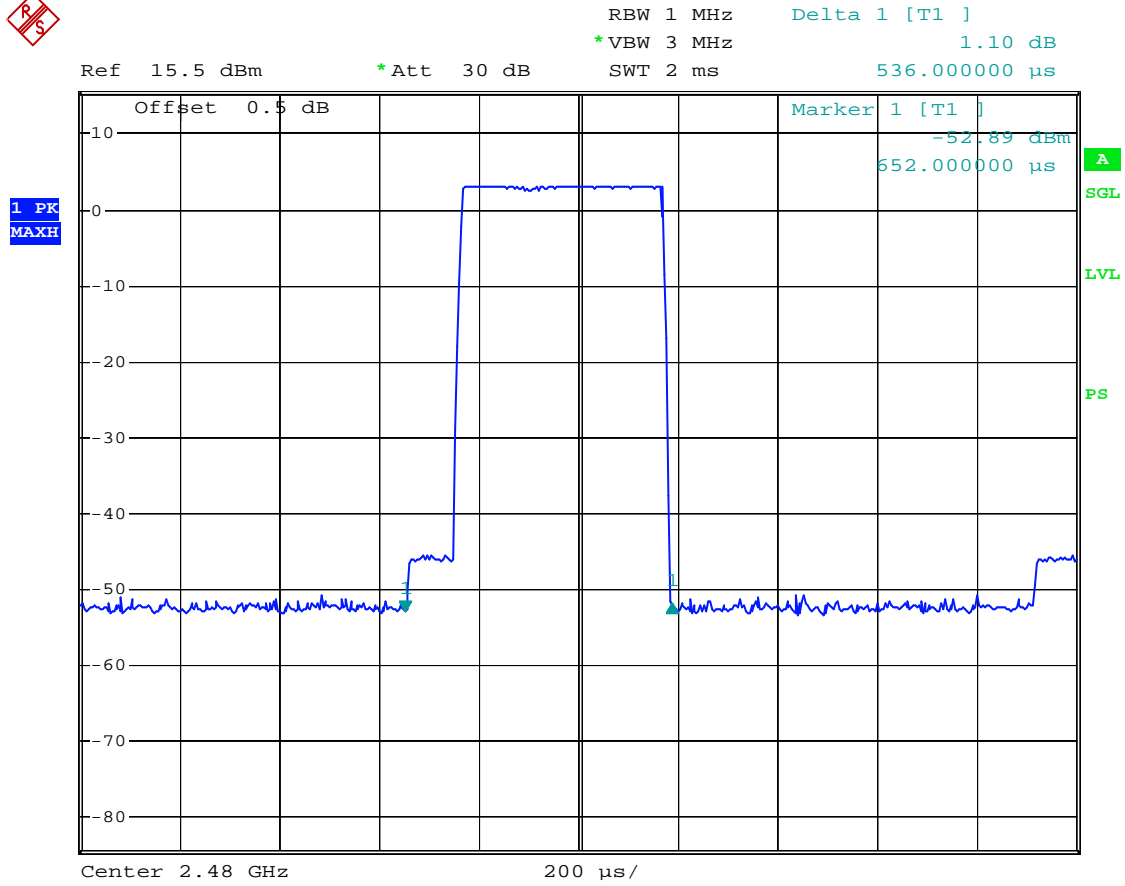

TOKWA Dwell time high channel dh1

Date: 2.AUG.2008 12:20:08



**DH3**

Channel	Pulse width (msec)	Dwell time (sec)	Limit (sec)	Result
Low	1.730	0.2768	0.4	Pass
Middle	1.810	0.2896	0.4	Pass
High	1.796	0.2874	0.4	Pass

*NOTE: Pulse time\*(1600/4/79)\*31.6S*

**Low Channel**

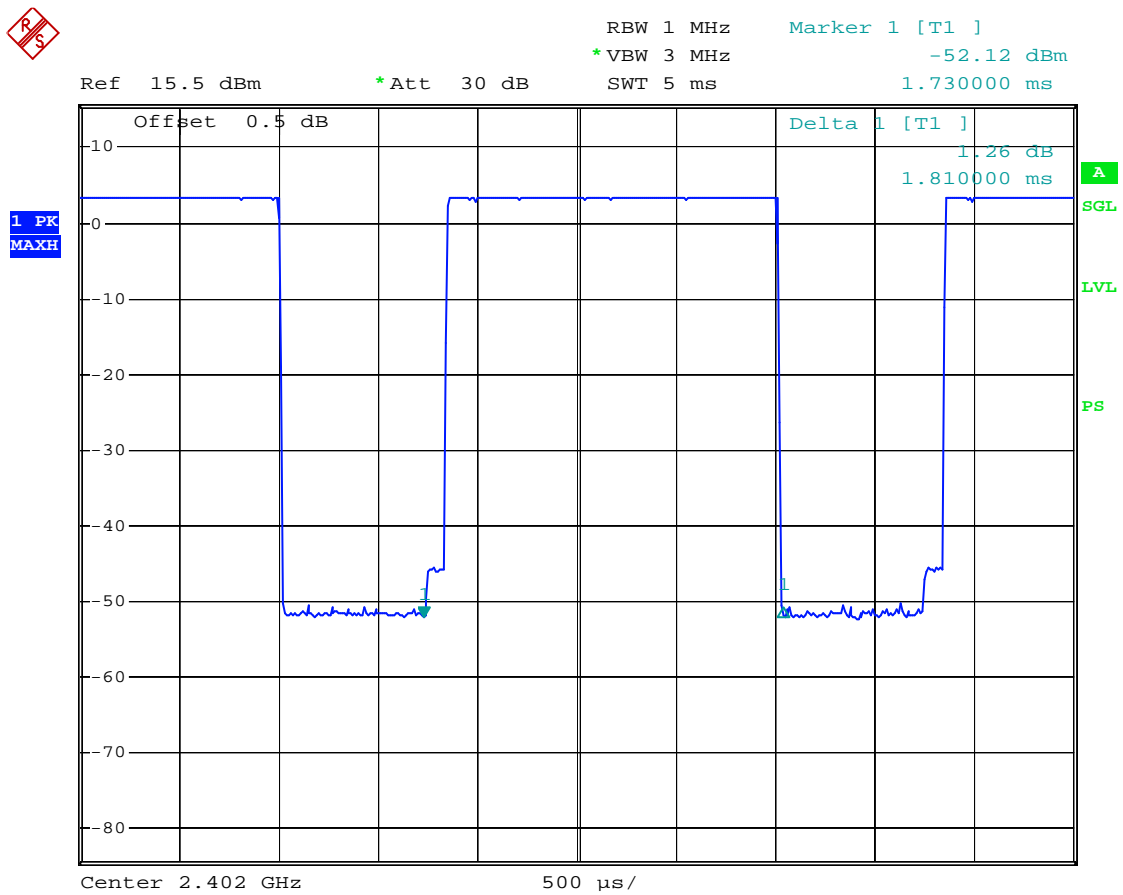

TOKWA Dwell time low channel dh3

Date: 2.AUG.2008 11:38:56

### Middle Channel

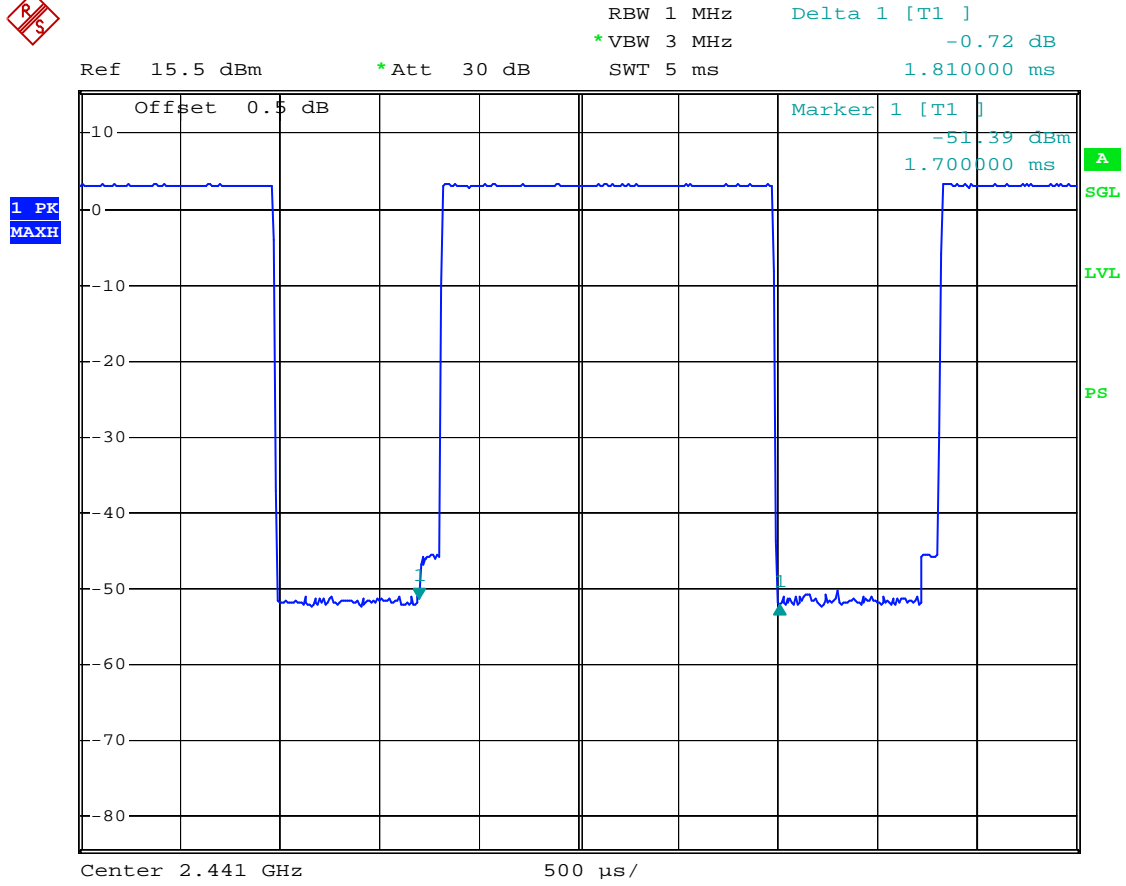

TOKWA Dwell time middle channel dh3

Date: 2.AUG.2008 12:15:52

### High Channel

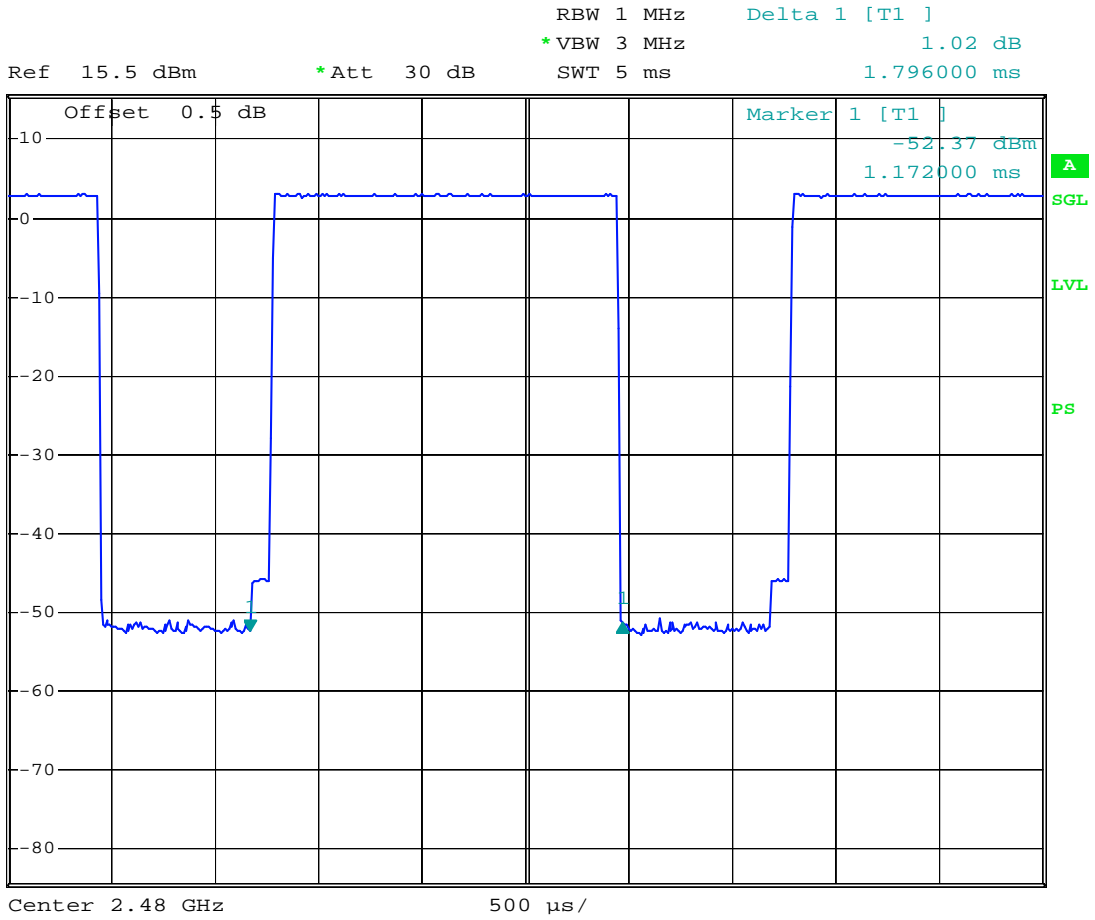

TOKWA Dwell time high channel dh3

Date: 2.AUG.2008 12:21:48

**DH5**

Channel	Pulse width (msec)	Dwell time (sec)	Limit (sec)	Result
Low	3.050	0.3253	0.4	Pass
Middle	3.050	0.3253	0.4	Pass
High	3.046	0.3249	0.4	Pass

*NOTE: Pulse time\*(1600/6/79)\*31.6S*

**Low Channel**

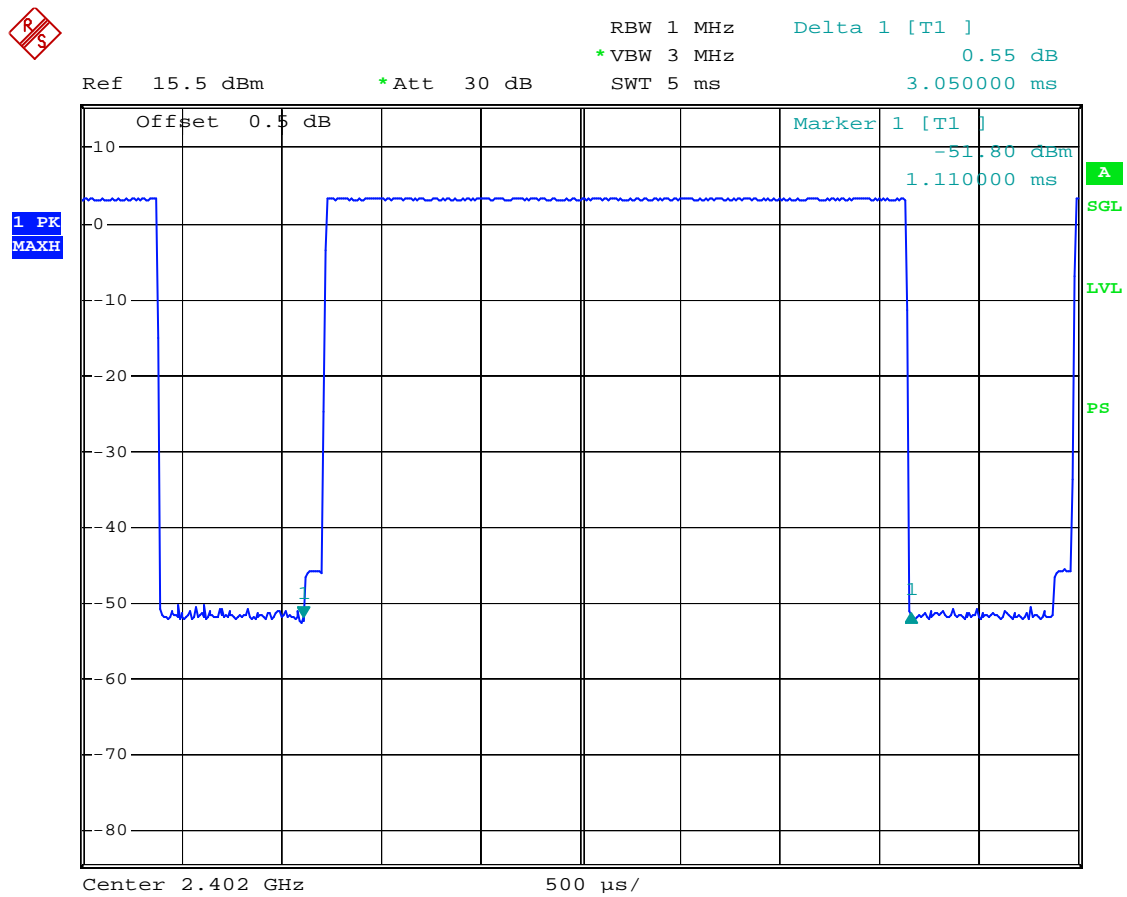

TOKWA Dwell time low channel dh5

Date: 2.AUG.2008 11:39:57

### Middle Channel

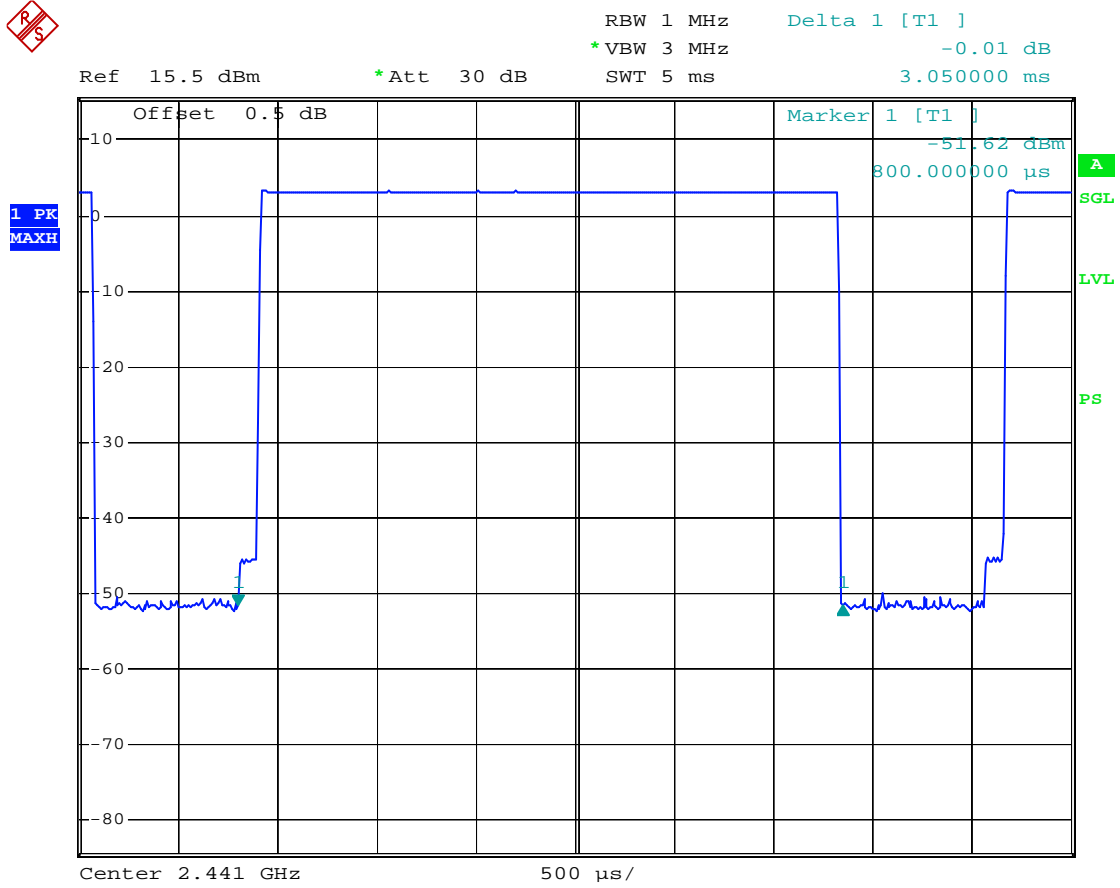

TOKWA Dwell time middle channel dh5

Date: 2.AUG.2008 12:14:26

### High Channel

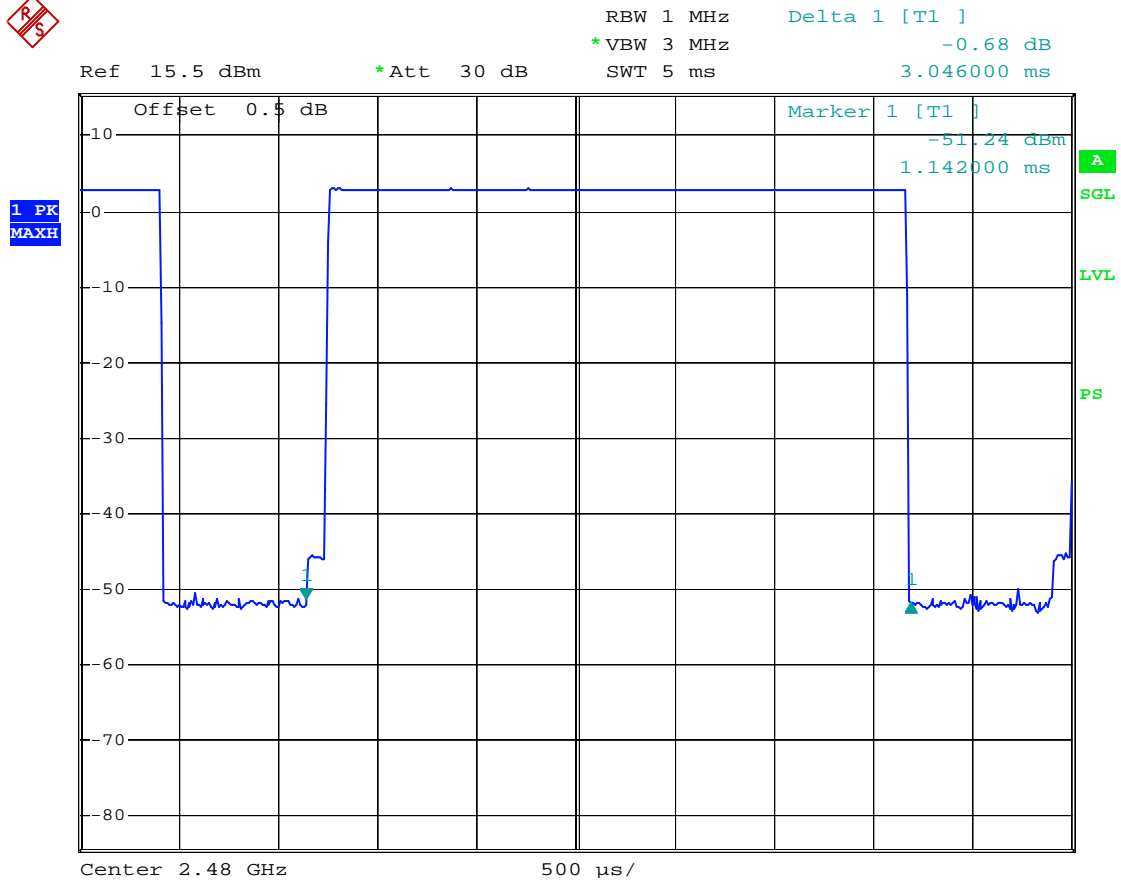

TOKWA Dwell time high channel dh5

Date: 2.AUG.2008 12:22:56

## CFR47 §15.247(b) (1) - PEAK OUTPUT POWER MEASUREMENT

### Applicable Standard

According to §15.247(b) (1), for frequency hopping systems operating in the 2400–2483.5 MHz band employing at least 75 non-overlapping hopping channels, and all frequency hopping systems in the 5725–5850 MHz band: 1 watt. For all other frequency hopping systems in the 2400–2483.5 MHz band: 0.125 watts.

### Test Equipment List and Details

Manufacturer	Description	Model	Serial Number	Calibration Date	Calibration Due Date
Rohde & Schwarz	EMI Test Receiver	ESCI	100035	2007-10-16	2008-10-16

\* **Statement of Traceability:** Bay Area Compliance Laboratories Corp. (Shenzhen) attests that all calibrations have been performed in accordance to NVLAP requirements, traceable to the NIST.

### Test Procedure

1. Place the EUT on a bench and set it in transmitting mode.
2. Remove the antenna from the EUT and then connect a low loss RF cable from the antenna port to an EMI Test Receiver.
3. Add a correction factor to the display.

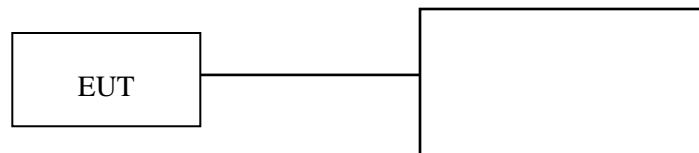

**Test Data****Environmental Conditions**

<b>Temperature:</b>	27 °C
<b>Relative Humidity:</b>	50 %
<b>ATM Pressure:</b>	100.9 kPa

*The testing was performed by Chris Peng on 2008-08-01.*

*Test Mode: Transmitting*

Channel	Channel Frequency (MHz)	Power Output		Limit (w)
		(dBm)	(mW)	
Low	2402	3.06	2.023	0.125
Mid	2441	3.00	1.995	0.125
High	2480	2.62	1.828	0.125

Please refer to the following plots.



### Low Channel



Ref 15.5 dBm      \*Att 30 dB      \*RBW 1 MHz      Marker 1 [T1 ]      3.06 dBm  
\*VBW 3 MHz      SWT 2.5 ms      2.401820000 GHz

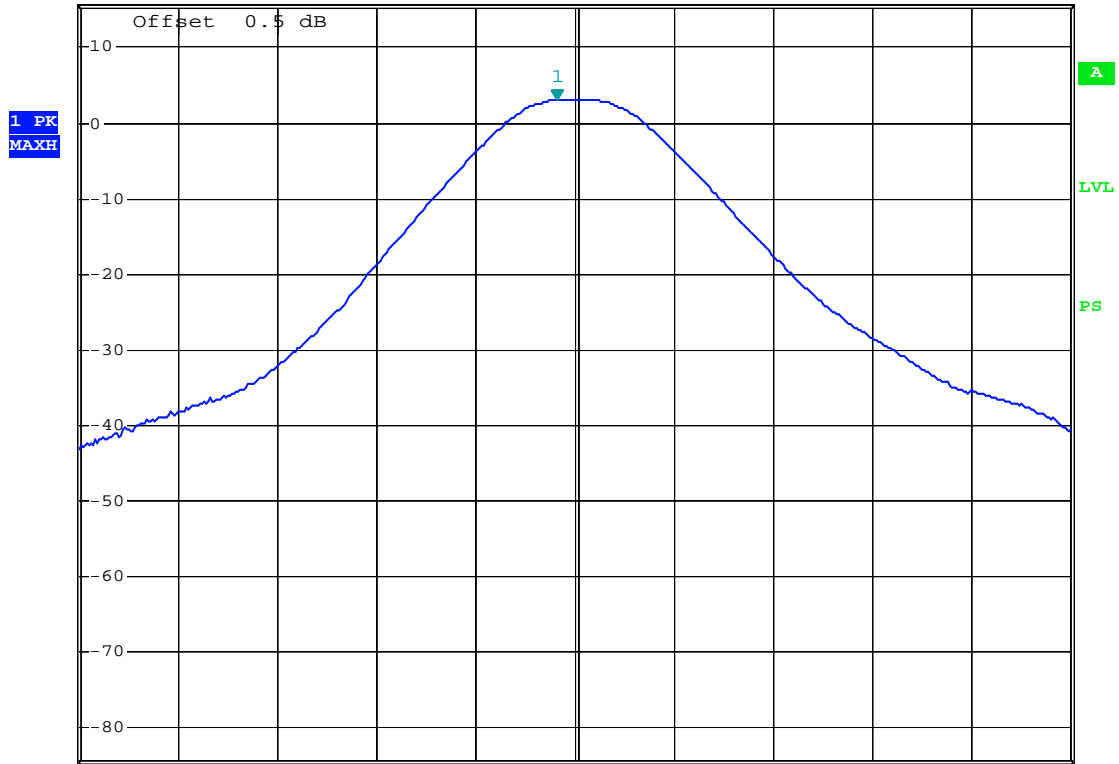

Center 2.402 GHz      1 MHz/      Span 10 MHz

TOKWA low channel peak output power

Date: 1.AUG.2008 22:13:27

### Middle Channel

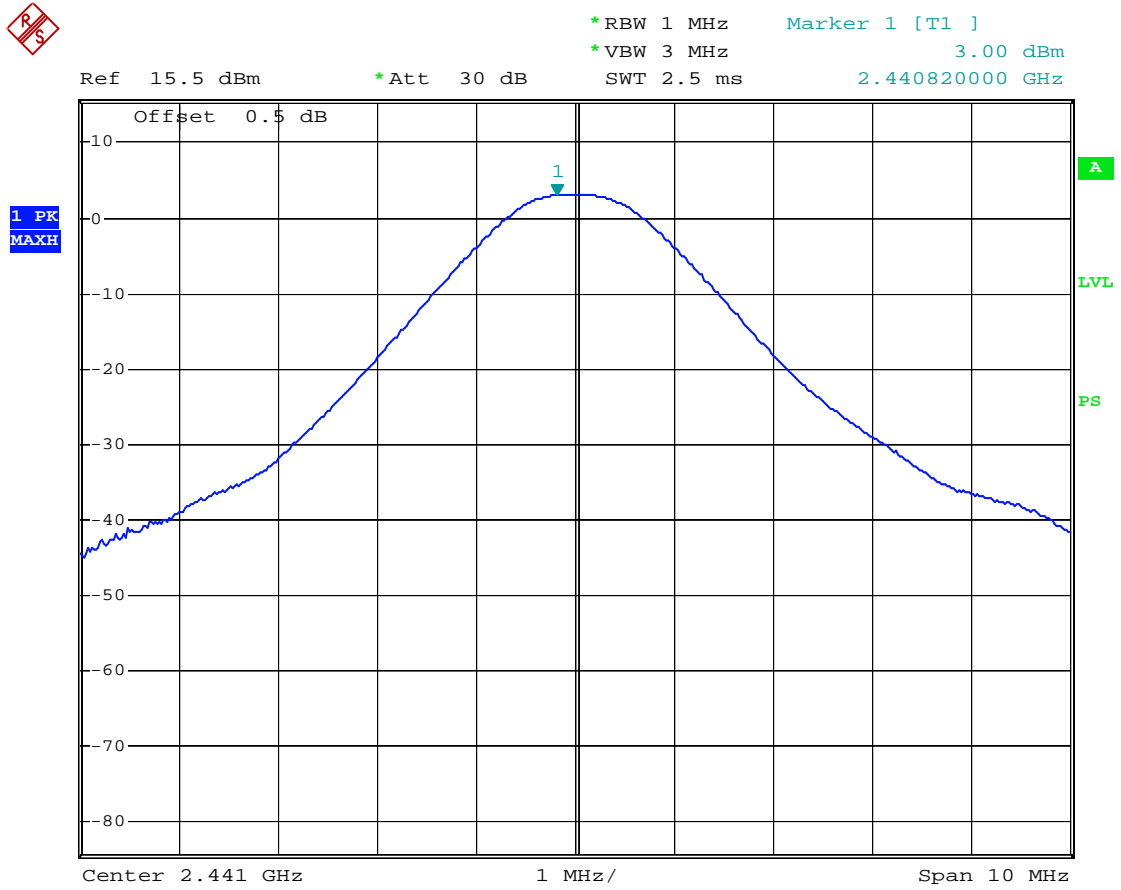

TOKWA middle channel peak output power

Date: 1.AUG.2008 22:15:02

### High Channel

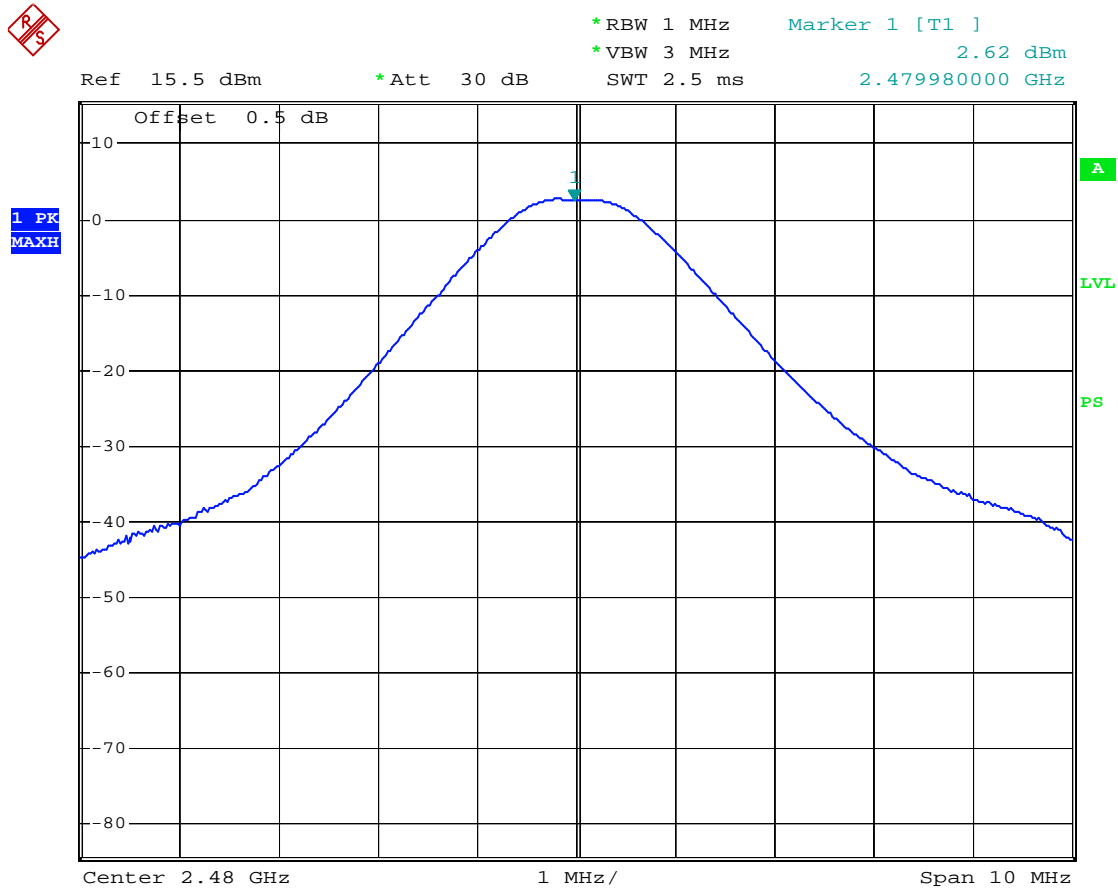

TOKWA high channel peak output power

Date: 1.AUG.2008 22:17:25

## CFR47 §15.247(d) - BAND EDGES TESTING

### Applicable Standard

In any 100 kHz bandwidth outside the frequency band in which the spread spectrum or digitally modulated intentional radiator is operating, the radio frequency power that is produced by the intentional radiator shall be at least 20 dB below that in the 100 kHz bandwidth within the band that contains the highest level of the desired power, based on either an RF conducted or a radiated measurement, provided the transmitter demonstrates compliance with the peak conducted power limits. If the transmitter complies with the conducted power limits based on the use of RMS averaging over a time interval, as permitted under paragraph (b)(3) of this section, the attenuation required under this paragraph shall be 30 dB instead of 20 dB. Attenuation below the general limits specified in §15.209(a) is not required. In addition, radiated emissions which fall in the restricted bands, as defined in §15.205(a), must also comply with the radiated emission limits specified in §15.209(a) (see §15.205(c)).

### Test Equipment List and Details

Manufacturer	Description	Model	Serial Number	Calibration Date	Calibration Due Date
Rohde & Schwarz	EMI Test Receiver	ESCI	100035	2007-10-16	2008-10-16

\* **Statement of Traceability:** Bay Area Compliance Laboratories Corp. (Shenzhen) attests that all calibrations have been performed in accordance to NVLAP requirements, traceable to the NIST.

### Test Procedure

1. Check the calibration of the measuring instrument using either an internal calibrator or a known signal from an external generator.
2. Position the EUT without connection to measurement instrument. Put it on the Rotated table and turn on the EUT and make it operate in transmitting mode. Then set it to Low Channel and High Channel within its operating range, and make sure the instrument is operated in its linear range.
3. Set both RBW and VBW of spectrum analyzer to 100 kHz with a convenient frequency span including 100kHz bandwidth from band edge, for Radiated emissions restricted band RBW=1MHz, VBW=3MHz.
4. Measure the highest amplitude appearing on spectral display and set it as a reference level. Plot the graph with marking the highest point and edge frequency.
5. Repeat above procedures until all measured frequencies were complete.

**Test Data****Environmental Conditions**

<b>Temperature:</b>	27 °C
<b>Relative Humidity:</b>	50 %
<b>ATM Pressure:</b>	100.9 kPa

*The testing was performed by Chris Peng on 2008-08-01.*

*Test Mode: Transmitting*

<b>Frequency (MHz)</b>	<b>Delta Peak to Band Emission (dBc)</b>	<b>Limit (dBc)</b>
2398.3460	45.91	20
2483.9560	45.36	20

### Low Band Edge

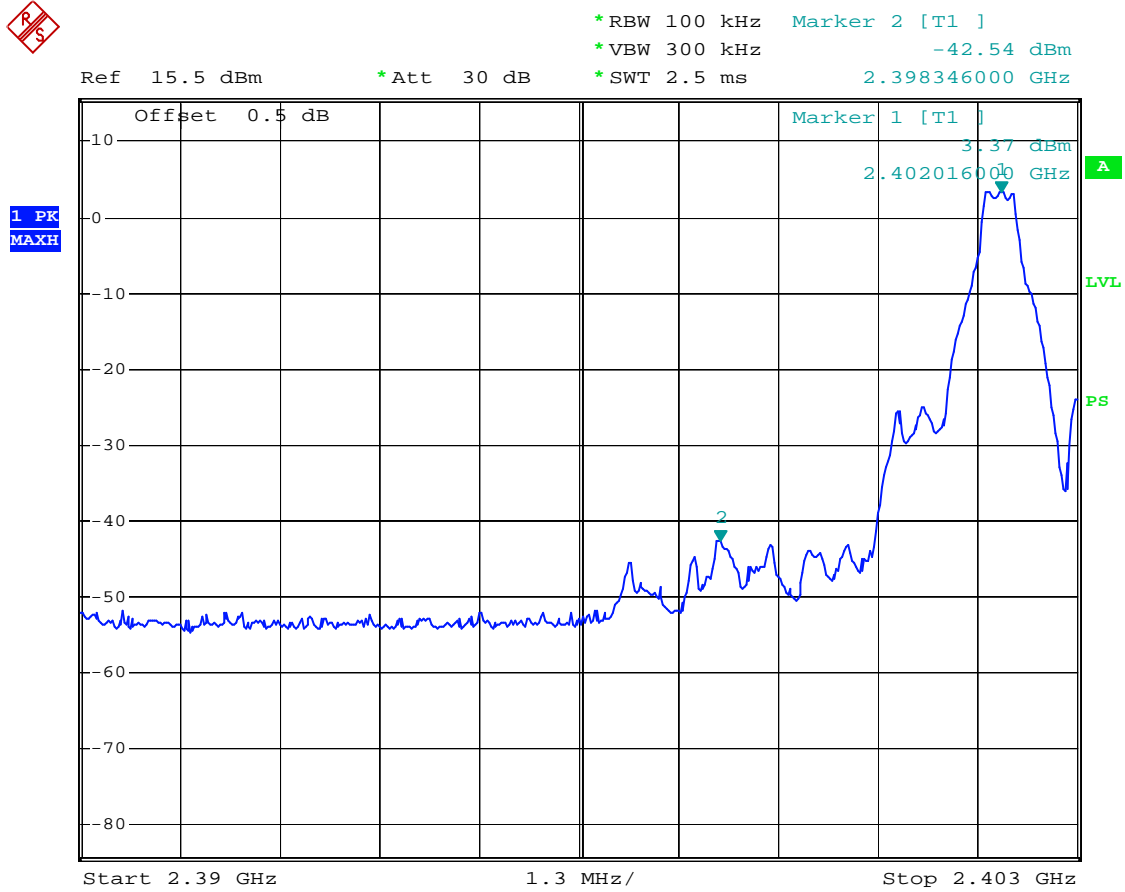

TOKWA band edge left

Date: 1.AUG.2008 23:35:20

### High Band Edge



Ref 15.5 dBm      \*Att 30 dB      \*RBW 100 kHz      Marker 2 [T1 ]  
\*VBW 300 kHz      -42.34 dBm  
\*SWT 2.5 ms      2.483956000 GHz

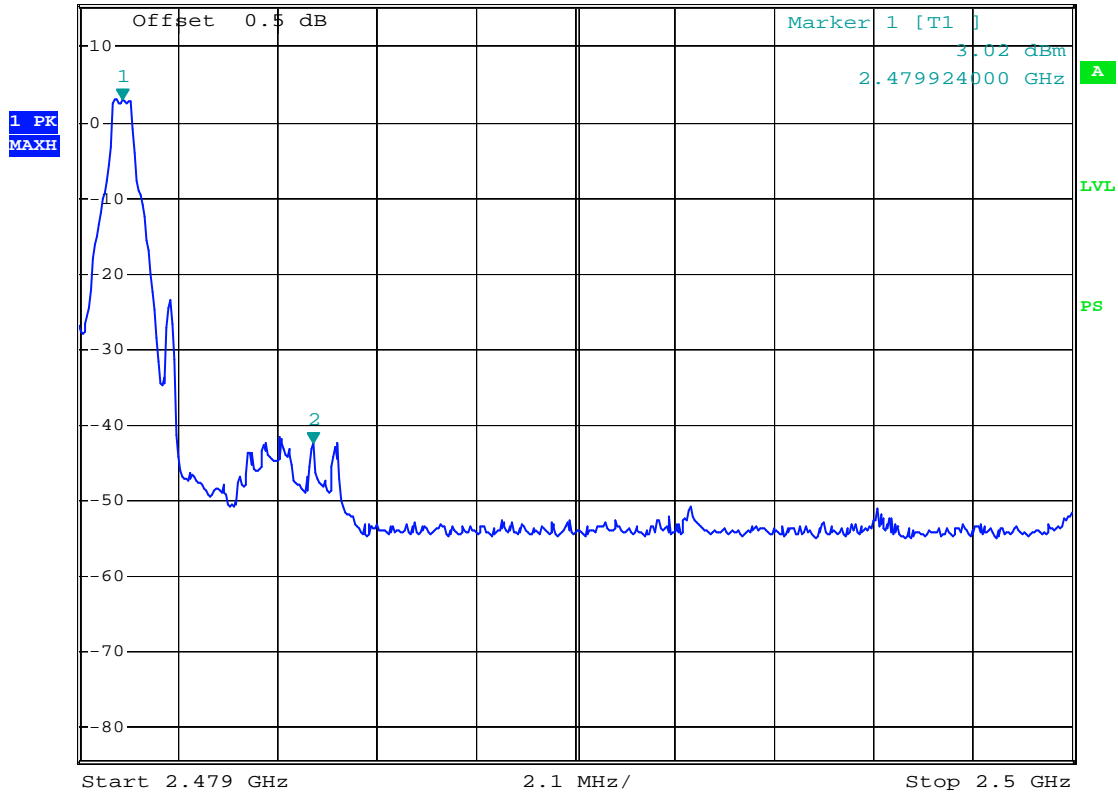

TOKWA band edge right

Date: 1.AUG.2008 23:38:56

\*\*\*\*\*END OF REPORT\*\*\*\*\*