



Test Report No. 9612335876

For Maytronics Ltd

Equipment Under Test:

Transceiver Module

Model: 99954735LF

**From The Standards Institution
Of Israel
Industry Division
Electronics & Telematics Laboratory
EMC Branch**



Certificate Number: AT-1359



Test report No: 9612335876
Title: Transceiver Module
Model: 99954735LF

Page 2 of 28 Pages

FCC ID: WCH99956BT

Table of Contents

1. Applicant information	3
2. Test performance	3
3. Summary of test:.....	5
4. Equipment under test description.....	6
4.1 General description	6
4.2 Test configuration.....	7
5. Test results	8
5.1 Transmitter characteristics	8
5.1.1 Transmitter 6 dB occupied bandwidth.....	8
5.1.2 Maximum peak conducted output power test.	10
5.1.3 Power spectral density test.....	12
5.1.4 Radiated emissions according to §§ 15.247(d), 15.205(a)	13
5.2 Radiated emissions test according to § 15.209	18
5.3 Conducted emissions test according to § 15.207.....	20
APPENDIX A Test equipment used.....	22
APPENDIX B Photo of the test setups.....	27
APPENDIX C Abbreviations and acronyms.	28



Test report No: 9612335876
Title: Transceiver Module
Model: 99954735LF

Page 3 of 28 Pages

FCC ID: WCH99956BT

1. Applicant information

Applicant:	Maytronics Ltd
Address:	Kibbutz Yizre'el, 19350 Israel
Sample for test selected by:	The customer
The date of tests:	10, 17 March, 10 May 2016

Equipment under test information

Description of Equipment Under Test (EUT):	Transceiver Module
Model:	99954735LF
Serial Number:	NA
Hardware version:	Revision 01
Software version:	Revision 11
Manufactured by:	Maytronics Ltd.

2. Test performance

Location:	SII EMC Section
Purpose of test:	Apparatus compliance verification in accordance with emission requirements
Test specifications:	47CFR part 15.247, 15.205 15.207. 15.209 and part 1 §1.1310

This Test Report contains 28 pages and may be used only in full.

This Test Report applies only to the specimen tested and may not be applied to other specimens of the same product.



Test report No: 9612335876

Page 4 of 28 Pages

Title: Transceiver Module

Model: 99954735LF

FCC ID: WCH99956BT

Normative References.

FCC 47 CFR Part 15, Subpart C, 2015	Radio Frequency Devices Subpart C – Intentional Radiators
ANSI C63.4: 2009	American National Standard for Method of Measurements of Radio-Noise Emissions from Low-Voltage Electrical and Electronic Equipment in the Range of 9 kHz to 40 GHz
ANSI C63.10: 2009	American National Standard for Testing of Unlicensed Wireless Devices.
FCC OET KDB 558074, January 2016	Guidance for Performing Compliance Measurements on Digital Transmission Systems (DTS) Operating Under §15.247



Test report No: 9612335876
Title: Transceiver Module
Model: 99954735LF

Page 5 of 28 Pages

FCC ID: WCH99956BT

3. Summary of test:

The EUT was found to be in compliance with requirements of: 47CFR Part 15, §§ 15.247, 15.205 and 15.209.

Transmitter characteristics	Subclasses
Minimum 6 dB bandwidth	15.247(a)(2)
Maximum output power	15.247(b)(3)
Peak power spectral density	15.247(e)
Out of band spurious emissions radiated	15.205, 15.247(d)
Conducted emissions on AC power line	15.207
Unwanted radiated emissions below 1 GHz	15.209

Electronics and Telematics Laboratory

June 2016

Name: Eng. Yuri Rozenberg
 Position: Head of EMC Branch

Name: Michael Feldman

Measurement uncertainty.

The test equipment has been calibrated according to its recommended procedures and is within the manufacturer's published limit of error.

The laboratory calibrates its standards by a third party (traceable to NIST, USA) on a regular basis according to equipment manufacturer requirements.

In the following table the uncertainty calculation is given.

Type of disturbance Test description	Calculated uncertainty U _{LAB}
<u>Radiated emissions</u> electric field strength in a SAR at 3 m distance 30 MHz – 1.0 GHz	4.32 dB
electric field strength in a FAR at 3 m distance 1.0 GHz – 18 GHz	4.47 dB
<u>Substitution measurements</u> in a FAR at 3 m distance 1.0 GHz – 18 GHz	3.41 dB

Test report No: 9612335876
Title: Transceiver Module
Model: 99954735LF

Page 6 of 28 Pages

FCC ID: WCH99956BT

4. Equipment under test description.

*The customer provided description.

4.1 General description

The EUT is a Transceiver module that communicates through BLE protocol to Smartphones that have installed the "My Dolphin" application. The user uses the Smartphone application to instruct the Transceiver module to operate different operation modes and features.

The power supply main module provides the voltage to operate the module.

This power supply is connected to the mains and is outputting to the robot 29VDC. This is an outdoor appliance. The communication module is mounted on the power supply front panel.

EUT technical characteristics

Transmitter technical characteristics.		Note
Assigned frequency band	2400 MHz – 2483.5 MHz	-
Operating frequency	2402 MHz – 2480 MHz	BLE transceiver
Programmable Output power	< 2 dBm	-
RF channel spacing:	2 MHz	-
Maximum data rate:	1 Mbit/s	-
Type of modulation:	GFSK	-
Duty cycle of transmitter during the tests.	100%	-
Antenna information		
Type	Manufacturer	Antenna gain, dBi
Internal on PCB	Maytronics Ltd	0

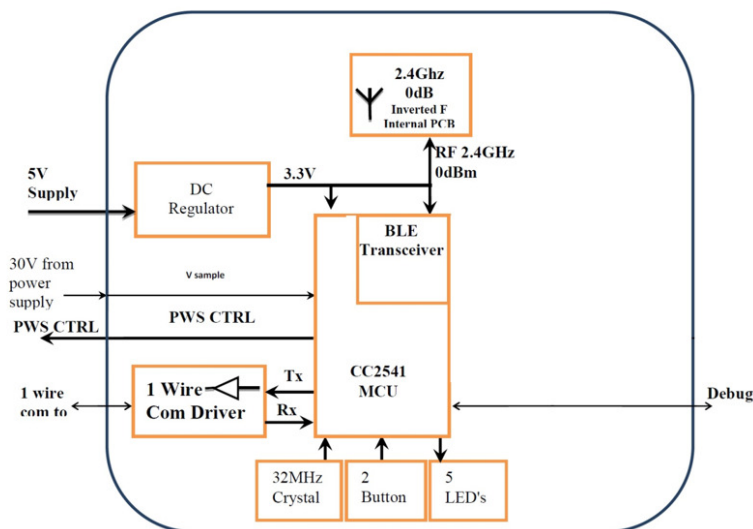

Fig. 1. Transmitter module block diagram.

Test report No: 9612335876
Title: Transceiver Module
Model: 99954735LF

Page 7 of 28 Pages

FCC ID: WCH99956BT

4.2 Test configuration

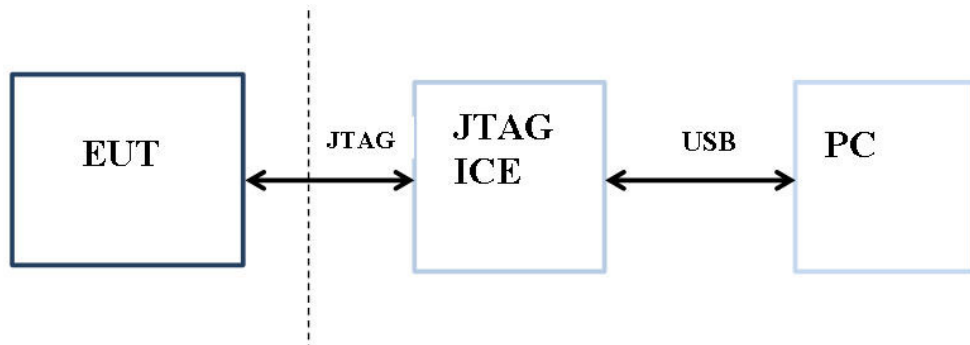

Fig. 2. Test configuration block diagram.

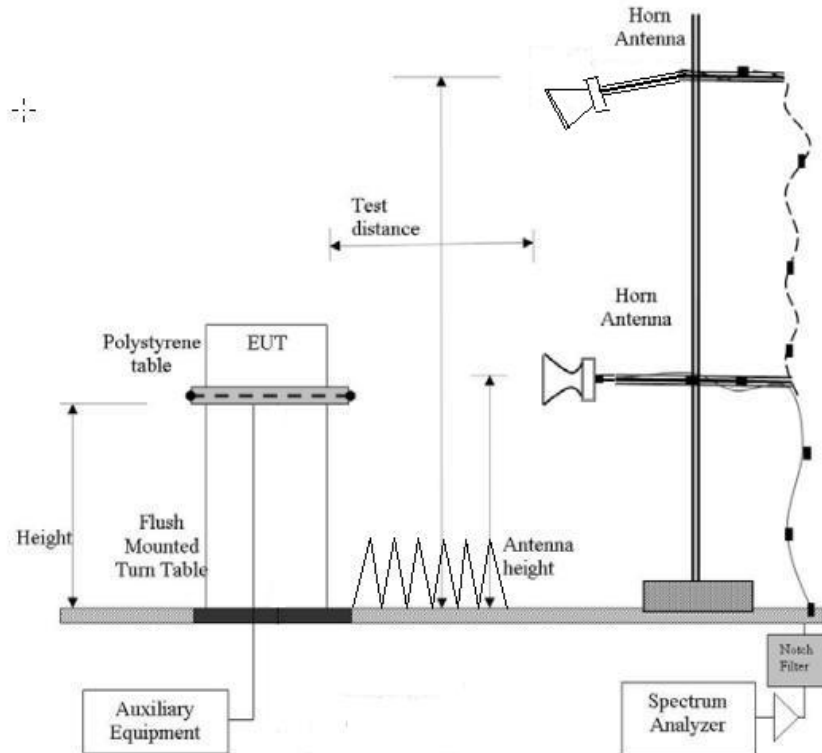

Fig.3. RE test setup above 1 GHz.



Test report No: 9612335876
Title: Transceiver Module
Model: 99954735LF

Page 8 of 28 Pages

FCC ID: WCH99956BT

5. Test results

5.1 Transmitter characteristics

5.1.1 Transmitter 6 dB occupied bandwidth.

Method of measurement	558074 D01 DTS Meas Guidance. Section 8.1				
Operating Frequency Range	2402– 2480 MHz				
Detector used	Peak				
Resolution bandwidth	100 kHz				
Video bandwidth	> 3 x RBW.				
Trace mode	Max Hold.				
Sweep time:	Auto couple.				
Ambient Temperature	24° C	Relative Humidity	51%	Air Pressure	1009 hPa

The minimum 6 dB occupied bandwidth shall be at least 500 kHz.

Carrier frequency, MHz	Measured 6 dB occupied bandwidth, kHz	Limit, kHz	Reference to plot#
2402	686	500	1
2440	683	500	2
2480	682	500	3

TEST EQUIPMENT USED:

1	5	15				
---	---	----	--	--	--	--



Test report No: 9612335876
Title: Transceiver Module
Model: 99954735LF

Page 9 of 28 Pages

FCC ID: WCH99956BT



Plot # 1

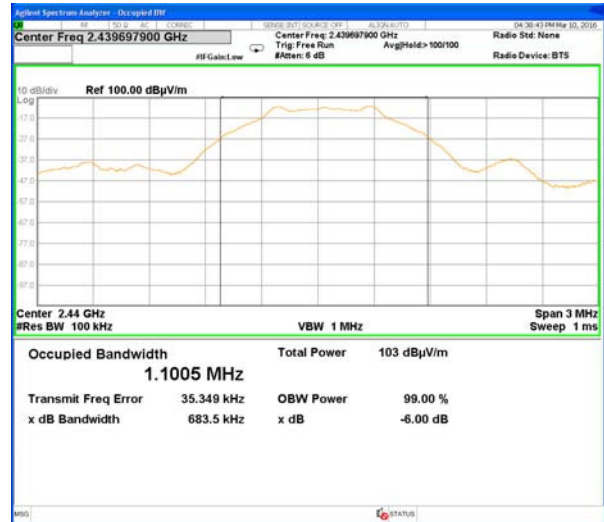

Plot # 2

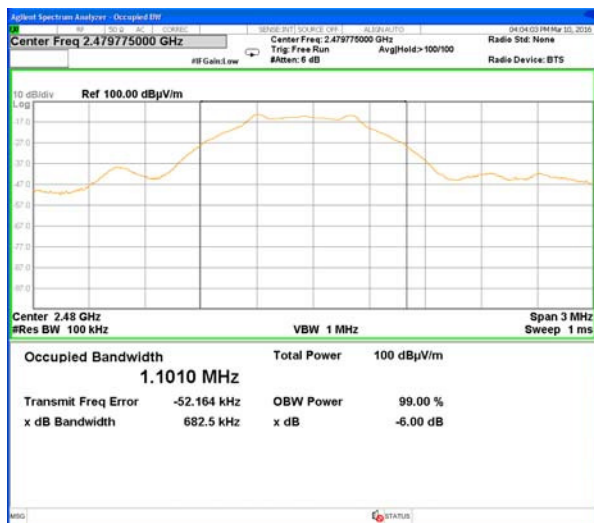

Plot # 3



Test report No: 9612335876
Title: Transceiver Module
Model: 99954735LF

Page 10 of 28 Pages

FCC ID: WCH99956BT

5.1.2 Maximum peak conducted output power test.

Method of measurement	558074 D01 DTS Meas Guidance. Section 9.1.1.				
Operating Frequency Range	2402– 2480 MHz				
Detector used	Peak				
Resolution bandwidth	3 MHz				
Video bandwidth	> RBW.				
Trace mode	Max Hold.				
Type of modulation:	GFSK				
Ambient Temperature	22° C	Relative Humidity	46%	Air Pressure	1009 hPa

For Digital Transmit System the peak conducted output power in the 2400 – 2483.5 MHz band shall not exceed: 1W (30 dBm) or 36 dBm EIRP with antennas gains not exceed 6 dBi.

Carrier frequency, MHz	EIRP power, dBm	EIRP limit, dBm	Reference to plots #
2402	1.6	36	4
2440	-0.1	36	5
2480	-0.6	36	6

The measurement provided according to ANSI/TIA-603-D-2010 section 2.2.17 substitution test method. Measurement of transmitter carrier emission level was performed. EUT was replaced by generator and substitution antenna. Result calculated from generator output level, substitution antenna gain and loss of connected cable was compared with the limit. Transmitter was operated at continuous transmit mode at bottom, middle and top of the 2400 – 2483.5 MHz frequency band.

TEST EQUIPMENT USED:

1	2	5	7	10	11	15
---	---	---	---	----	----	----



Test report No: 9612335876
Title: Transceiver Module
Model: 99954735LF

Page 11 of 28 Pages

FCC ID: WCH99956BT



Plot # 4. Carrier frequency – 2402 MHz.



Plot # 5. Carrier frequency – 2440 MHz.



Plot # 6. Carrier frequency – 2480 MHz.



Test report No: 9612335876
Title: Transceiver Module
Model: 99954735LF

Page 12 of 28 Pages

FCC ID: WCH99956BT

5.1.3 Power spectral density test

Method of measurement	558074 D01 DTS Meas Guidance. Section 10.1.				
Operating Frequency Range	2402– 2480 MHz				
Detector used	Peak				
Resolution bandwidth	3 – 100 kHz				
Video bandwidth	> RBW.				
Trace mode	Max Hold.				
Type of modulation:	GFSK				
Ambient Temperature	24 ⁰ C	Relative Humidity	47%	Air Pressure	1007 hPa

For digitally modulated systems, the power spectral density conducted from the intentional radiator to the antenna shall not be greater than 8 dBm in any 3 kHz band during any time interval of continuous transmission.

TEST SUMMARY

EUT peak output power result is below PSD limit per 47 CFR 15.247 (e).
PSD level is equal to the measured output power.
The EUT was found complies with standard requirement.

TEST EQUIPMENT USED:

1	2	5	7	10	11	15
---	---	---	---	----	----	----

**Test report No:** 9612335876

Page 13 of 28 Pages

Title: Transceiver Module**Model:** 99954735LF

FCC ID: WCH99956BT

5.1.4 Radiated emissions according to §§ 15.247(d), 15.205(a)

Method of measurement	558074 D01 DTS Meas Guidance. Sec. 12.1.					
Operating Frequency Range	2402– 2480 MHz					
Detector used	Trace 1 – Peak; Trace 2 - Average					
Resolution bandwidth	120 kHz /1.0 MHz					
Video bandwidth	> RBW.					
Trace mode	Max Hold.					
Ambient Temperature	24° C	Relative Humidity	47%	Air Pressure	1007 hPa	

In any 100 kHz bandwidth outside the frequency band in which the spread spectrum or digitally modulated intentional radiator is operating, the radio frequency power that is produced by the intentional radiator shall be at least 20 dB below that in the 100 kHz bandwidth within the band that contains the highest level of the desired power, based on a radiated measurement, provided the transmitter demonstrates compliance with the peak conducted power limits.

In addition, radiated emissions which fall in the restricted bands, as defined in Section 15.205(a) must also comply with the radiated emission limits specified in Section 15.209(a).

Carrier frequency 2402 MHz

Frequency, MHz	Radiated emissions, dB μ V/m	Peak limit, dB μ V/m	Avg limit, dB μ V/m	Margin, dB	Note	Note	Reference to plot#
2390.0	53.2	74	-	>20	RB	Detector peak	7
2390.0	42.5	-	54	11.5	RB	Detector average	7
2399	68.2	77.0	-	8.8	Band edge	Detector peak.	8
4868	59.3	74	-	19.7	RB	Detector peak	10
4868	42.4	-	54	11.6	RB	Detector average	10
12345	57.1	74		16.9	RB	Detector peak	11
12345	45.6		54	8.4	RB	Detector average	11
23810	48.6	74		>20	RB	Detector peak	12
23830	37.6		54	16.4	RB	Detector average	12



Test report No: 9612335876
Title: Transceiver Module
Model: 99954735LF

Page 14 of 28 Pages

FCC ID: WCH99956BT

Carrier frequency 2440 MHz

Frequency, MHz	Radiated emissions, dB μ V/m	Peak limit, dB μ V/m	Avg limit, dB μ V/m	Margin, dB	Note	Note	Reference to plot#
2323.3	50.31	74	-	>20	RB	Detector peak	13
2387.9	38.4	-	54	15.6	RB	Detector average	13
2400	55.3	75.7	-	>20	Band edge	Detector peak.	14
2484.2	52.2	74	-	>20	RB	Detector peak	15
2489.0	40.5	-	54	13.5	RB	Detector average	15
13281	57.1	74	-	16.9	RB	Detector peak	17
13281	45.7	-	54	8.3	RB	Detector average	17

Carrier frequency 2480 MHz

Frequency, MHz	Radiated emissions, dB μ V/m	Peak limit, dB μ V/m	Avg limit, dB μ V/m	Margin, dB	Note	Note	Reference to plot#
2483.5	55.4	73.5	-	18.1	Band edge	Detector peak.	20
2484.5	57.7	74	-	16.3	RB	Detector peak	21
2485.4	48.0	-	54	6.0	RB	Detector average	21
13308.0	56.9	74	-	17.1	RB	Detector peak	23
13308.0	45.9	-	54	8.1	RB	Detector average	23

TEST SUMMARY

All emissions outside of the 2400 – 2483.5 MHz band were found below 15.247(d) limits.

TEST EQUIPMENT USED:

1	2	5	6	15	16		
---	---	---	---	----	----	--	--



Test report No: 9612335876
Title: Transceiver Module
Model: 99954735LF

Page 15 of 28 Pages

FCC ID: WCH99956BT

Carrier frequency – 2402 MHz



Plot # 7

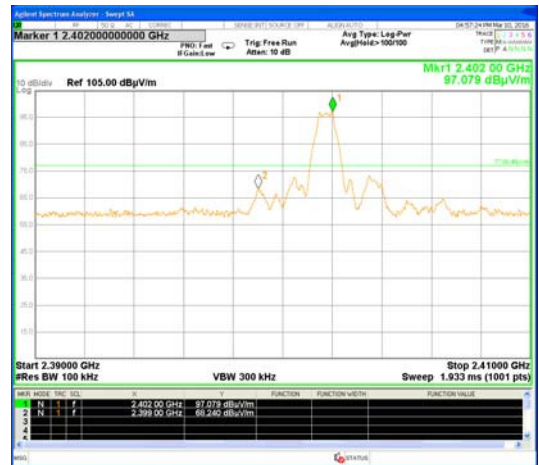

Plot # 8



Plot # 9



Plot # 10



Plot # 11.



Plot # 12.



Test report No: 9612335876
Title: Transceiver Module
Model: 99954735LF

Page 16 of 28 Pages

FCC ID: WCH99956BT

Carrier frequency - 2440 MHz.

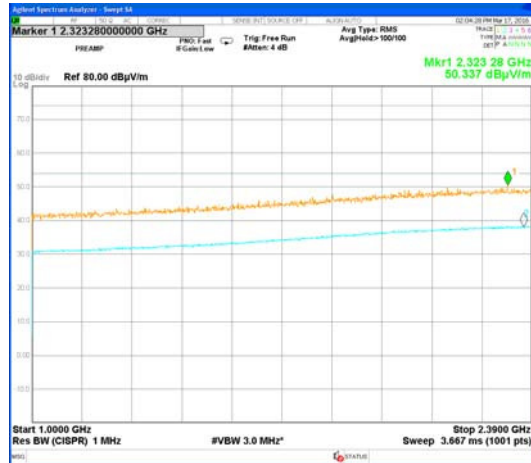

Plot # 13

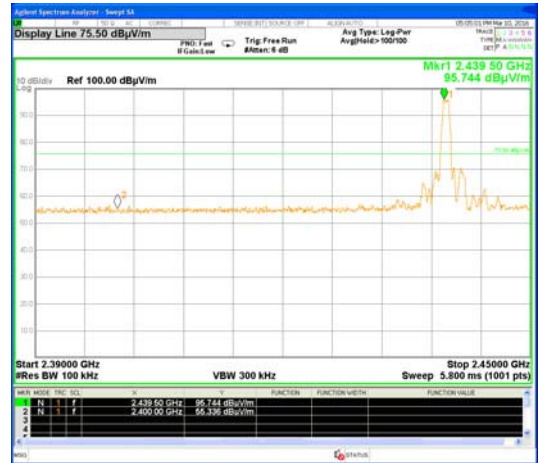

Plot # 14



Plot # 15



Plot # 16



Plot # 17.

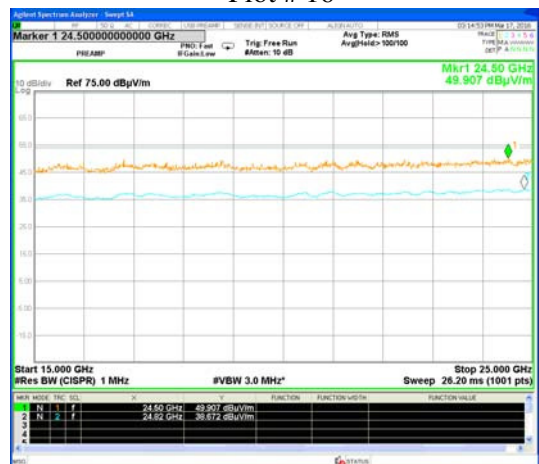

Plot # 18.



Test report No: 9612335876
Title: Transceiver Module
Model: 99954735LF

Page 17 of 28 Pages

FCC ID: WCH99956BT

Carrier frequency 2480 MHz

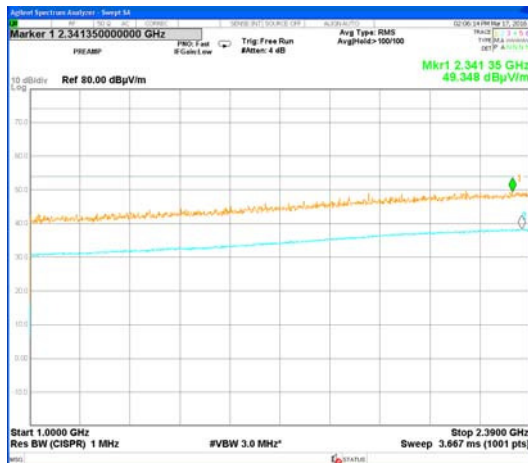

Plot # 19

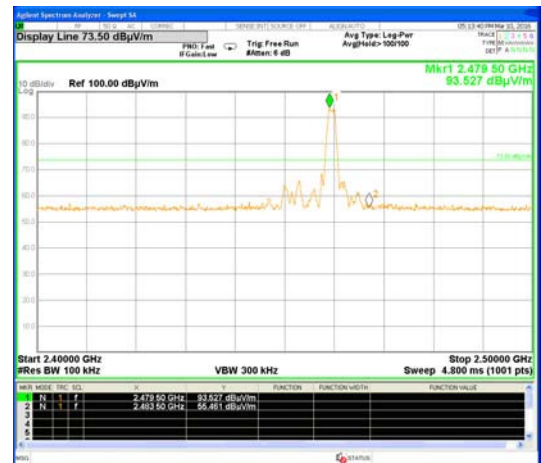

Plot # 20



Plot # 21



Plot # 22



Plot # 23



Plot # 24.



Test report No: 9612335876

Page 18 of 28 Pages

Title: Transceiver Module

Model: 99954735LF

FCC ID: WCH99956BT

5.2 Radiated emissions test according to § 15.209

Method of measurement	ANSI C63.10 § 5				
Detector used	CISPR Quasi-Peak				
Resolution bandwidth	9 kHz/120 kHz				
Video bandwidth	>3 x RBW.				
Trace mode	Free run				
Ambient Temperature	24° C	Relative Humidity	55%	Air Pressure	1012 hPa

TEST DESCRIPTION:

The measurements were performed at 3m test distance in Anechoic chamber. The EUT was arranged on a polystyrene table 0.8 m height placed on the turn - table. The Active Loop antenna in 9 kHz to 30 MHz frequency band and Biconilog antenna in 30 MHz – 1.0 GHz frequency band were used. The emission level was maximized by initially rotating turntable through 360°, varying the antenna height between 1 m and 4 m, rerouting EUT cables and changing antenna polarization from vertical to horizontal.

REQUIREMENTS:

EUT radiated emission shall not exceed value required in section 15.209

TEST RESULT:

Test results are presented in a plots ## 25 - 27

TEST EQUIPMENT USED:

1	8	15	17			
---	---	----	----	--	--	--



Test report No: 9612335876
Title: Transceiver Module
Model: 99954735LF

Page 19 of 28 Pages

FCC ID: WCH99956BT

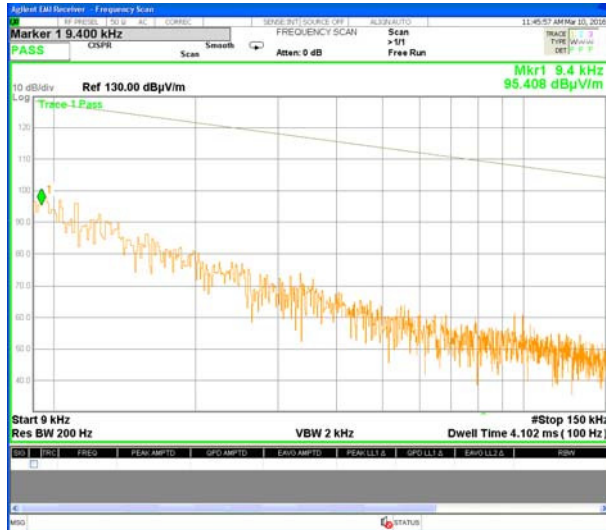

Plot # 25

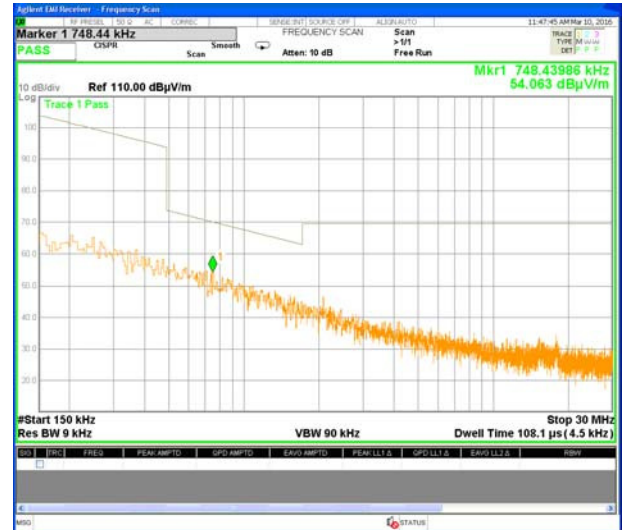

Plot # 26

Investigation result in 0.009 – 30 MHz frequency range.

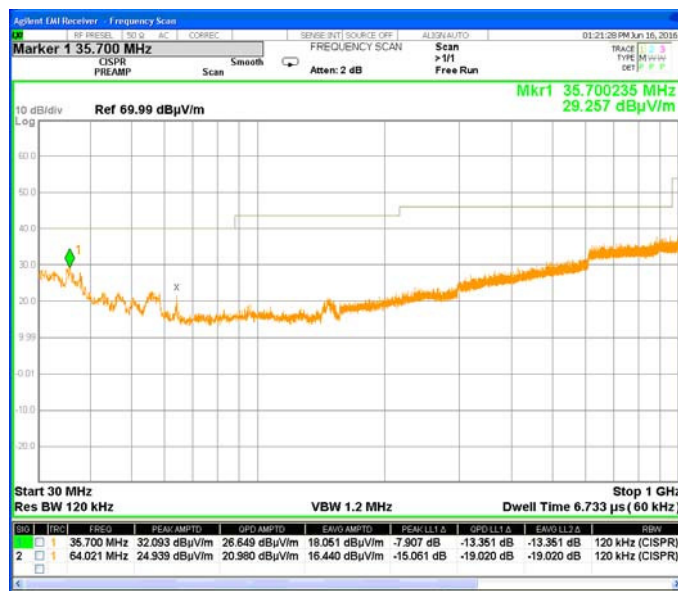

Plot # 27. Investigation result in 30 - 1000 MHz frequency range.



Test report No: 9612335876	Page 20 of 28 Pages
Title: Transceiver Module	
Model: 99954735LF	FCC ID: WCH99956BT

5.3 Conducted emissions test according to § 15.207.

Method of measurement ANSI C63.4 §13.3
Ambient Temperature 23° C Relative Humidity 52% Air Pressure 1008 hPa

Frequency, MHz	Conducted limit, dBµV	
	QP	AVRG
0.15 - 0.5	66 - 56*	56 - 46*
0.5 - 5	56	46
5 - 30	60	50

* Decreases with the logarithm of the frequency.

TEST PROCEDURE

EUT was placed on a wooden table in a shielded chamber at a height of 80 cm from the floor and 40 cm from the vertical reference plane. The measurements were performed at mains terminals by means of LISN, connected to spectrum analyzer. The measurements were made with quasi-peak and average (CISPR) detectors. The position of the EUT cables was varied to determine maximum emission level.

TEST RESULTS:

Test results are present at plots # 28 for line Phase and # 29 for line Neutral.

TEST EQUIPMENT USED:

1	13	14			
---	----	----	--	--	--



Test report No: 9612335876
Title: Transceiver Module
Model: 99954735LF

Page 21 of 28 Pages

FCC ID: WCH99956BT

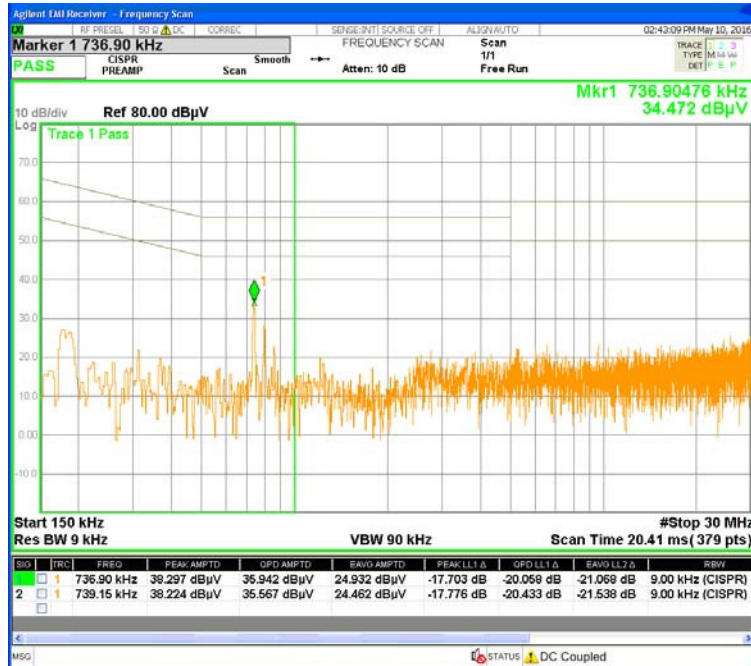

Plot # 28. AC line conducted emissions test. Line Phase

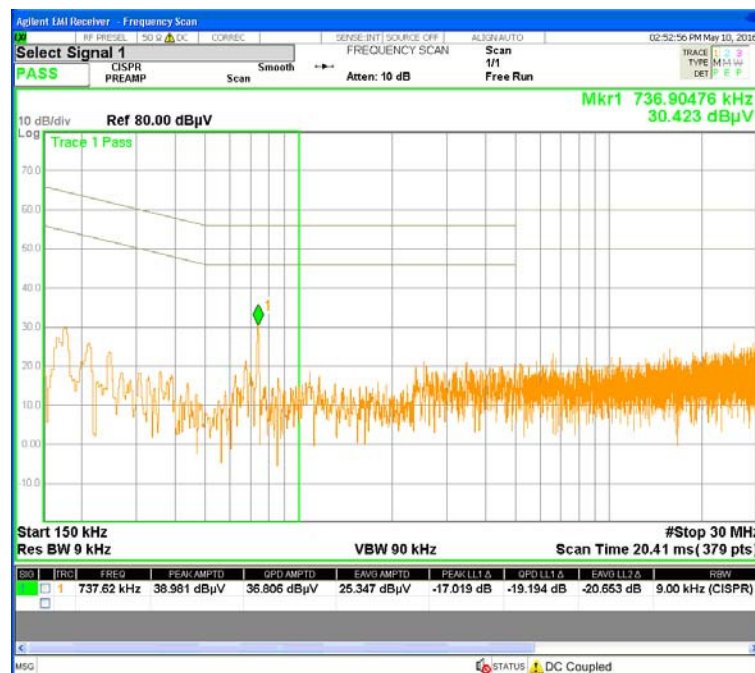

Plot # 29. AC line conducted emissions test. Line Neutral

**Test report No:** 9612335876

Page 22 of 28 Pages

Title: Transceiver Module**Model:** 99954735LF

FCC ID: WCH99956BT

APPENDIX A Test equipment used.**Test equipment used**

No	Description	Manufacturer information			Due Calibration date
		Name	Model	Serial No	
1	MXE EMI Receiver 20 Hz -26.5 GHz	Agilent	N9038A	SII 650114	March 2017
2	Cable RF 1m	Huber-Suhner	Sucoflex 104	21325/4PE	October 2016
3	EPM Series Power Meter	HP	E4418A	US38261895	May 2017
4	E-Series Avg. Power Sensor 10 MHz – 6.0 GHz	Agilent	E9301A	MY41498740	May 2017
5	Double Ridged Guide Antenna 0.75 – 18 GHz	ETS-Lindgren	3115	00143138	December 2016
6	Broadband Horn antenna 15 – 40 GHz	Schwarzbeck Mess-Electronik	BBHA 9170	9170-341	December 2016
7	Double Ridged Waveguide Horn Antenna 1 – 18 GHz	ETS-Lindgren	3117	00139055	December 2016
8	Antenna Biconilog 26 – 6000 MHz	ETS-Lindgren	31142D	0146490	December 2016
9	Spectrum analyzer 20 Hz-40 GHz	Rohde&Schwarz	ESU 40	100168	November 2016
10	MXG Signal Generator 100 KHz - 20 GHz	Agilent	N5183A	6501148	May 2017
11	Attenuator 3 dB DC – 12.4 GHz	HP	8491A	50469	October 2016
12	EMI Receiver 9 kHz-6.5 GHz	HP	8546A+85460A	SII 4068	May 2017
13	LISN 9 kHz – 30 MHz	FCC	LISN 250-32-4-16	SII5023	October 2016
14	Transient limiter 0.009-200 MHz	HP	11947A	3107105	August 2016
15	Cable RF 4m	Huber-Suhner	Sucoflex 104PE	21329/4PE	October 2016
16	USB preamplifier 2 GHz – 50 GHz	Keysight	U7227F	MY55380004	January 2017
17	Active Loop antenna 1.0 kHz – 30 MHz	ETS-Lindgren	6507	00144641	December 2016



Test report No: 9612335876

Page 23 of 28 Pages

Title: Transceiver Module

Model: 99954735LF

FCC ID: WCH99956BT

Cable Loss (Mast 6 m set cable.)

Point	Frequency (MHz)	Cable Loss (dB)	Point	Frequency (MHz)	Cable Loss (dB)
1	30	0.3	21	1000	2.5
2	50	0.4	22	1100	2.6
3	100	0.6	23	1200	2.8
4	150	0.8	24	1300	2.9
5	200	1.0	25	1400	3.1
6	250	1.1	26	1500	3.2
7	300	1.2	27	1600	3.3
8	350	1.3	28	1700	3.5
9	400	1.5	29	1800	3.6
10	450	1.6	30	1900	3.7
11	500	1.7	31	2000	3.9
12	550	1.8	32	2100	4.0
13	600	1.9	33	2200	4.1
14	650	1.9	34	2300	4.2
15	700	2.0	35	2400	4.4
16	750	2.1	36	2500	4.6
17	800	2.1	37	2600	4.7
18	850	2.2	38	2700	4.8
19	900	2.3	39	2800	4.9
20	950	2.4	40	2900	5.0



Test report No: 9612335876

Page 24 of 28 Pages

Title: Transceiver Module

Model: 99954735LF

FCC ID: WCH99956BT

Antenna factor
Biconilog Antenna, ETS-Lindgren mod. 31142D, S/N: 0146490 3m calibration.

No.	f / MHz	AF / dB/m	f / MHz	AF / dB/m	f / MHz	AF / dB/m
1	30	18.7	250	12.0	2750	31.0
2	35	15.7	300	13.8	3000	31.2
3	40	12.9	400	16.2	3250	32.7
4	45	10.6	500	18.6	3500	34.5
5	50	9.0	600	20.2	3750	34.3
6	60	7.3	700	21.8	4000	34.5
7	70	7.7	800	22.9	4250	35.3
8	80	8.2	900	24.1	4500	35.5
9	90	9.2	1000	24.8	4750	36.1
10	100	9.4	1250	26.9	5000	37.4
11	120	8.5	1500	30.2	5250	38.4
12	140	8.5	1750	28.5	5000	39.9
13	160	9.1	2000	28.9	5750	38.2
14	180	10.5	2250	29.8	6000	39.1
15	200	10.9	2500	32.5	-	-

**Test report No:** 9612335876

Page 25 of 28 Pages

Title: Transceiver Module**Model:** 99954735LF

FCC ID: WCH99956BT

Antenna Factor**Double Ridged Guide Antenna mfr ETS-Lindgren model 3115 1m calibration**

Point	Frequency (MHz)	Antenna Factor (dB/m)
1	1000	23.7
2	1500	25.5
3	2000	28.5
4	2500	28.1
5	3000	29.6
6	3500	31.1
7	4000	32.5
8	4500	32.5
9	5000	33.5
10	5500	34.7
11	6000	36.1
12	6500	36.5
13	7000	37.3
14	7500	38.0
15	8000	37.3
16	8500	37.9
17	9000	38.1
18	9500	38.5
19	10000	38.7
20	10500	38.8
21	11000	38.6
22	11500	38.8
23	12000	38.9
24	12500	39.3
25	13000	40.2
26	13500	40.6
27	14000	40.6
28	14500	40.4
29	15000	39.6
30	15500	39.5
31	16000	39.8
32	16500	40.4
33	17000	41.3
34	17500	42.6
35	18000	43.2

Cable Loss**Type: Sucoflex 104PE; Ser.No.21329/4PE; 4 m length**

Point	Frequency (GHz)	Cable Loss (dB)
0	0.0-1.8	1.67
1	1.8 – 3.6	2.39
2	3.6 – 5.4	3.04
3	5.4-7.2	3.58
4	7.2-9.0	4.06
5	9.0-10.8	4.49
6	10.8-12.6	4.91
7	12.6-14.4	5.31
8	14.4-16.2	5.66
9	16.2-18.00	6.01



Test report No: 9612335876

Page 26 of 28 Pages

Title: Transceiver Module

Model: 99954735LF

FCC ID: WCH99956BT

Antenna Factor
Broadband Horn Antenna model BBHA 9170 1m calibration

Point	Frequency (GHz)	Antenna Factor (dB/m)
1	15.0	38.5
2	16.0	37.7
3	17.0	38.1
4	18.0	37.9
5	19.0	38.0
6	20.0	38.0
7	21.0	37.9
8	22.0	38.2
9	23.0	39.6
10	24.0	39.6
11	25.0	39.3
12	26.0	39.5
13	27.0	39.6
14	28.0	39.6
15	30.0	40.1
16	32.0	41.2
17	34.0	41.5
18	35.0	41.9
19	36.0	42.2
20	38.0	43.8
21	40.0	43.2

Antenna Factor
For Antenna Loop MFR ETS Lindgren, Type/Model 6507, S/N: 00144641

No.	Frequency MHz	Magnetic antenna factor, dBS/m	Electric antenna factor, dB/m
1	9	-21.5	30.0
2	10	-22.0	29.5
3	20	-27.7	23.8
4	50	-32.2	19.4
5	75	-33.0	18.5
6	100	-33.4	18.2
7	150	-33.6	17.9
8	250	-33.7	17.9
9	500	-33.8	17.8
10	750	-33.8	17.7
11	1000	-33.8	17.7
12	2000	-33.7	17.9
13	3000	-33.8	17.8
14	4000	-34.0	17.5
15	5000	-34.3	17.2
16	10000	-35.2	16.4
17	15000	-35.8	15.8
18	20000	-36.0	15.6
19	25000	-36.2	15.3
20	30000	-36.4	15.2



Test report No: 9612335876
Title: Transceiver Module
Model: 99954735LF

Page 27 of 28 Pages

FCC ID: WCH99956BT

APPENDIX B Photo of the test setups.



Photo 1.

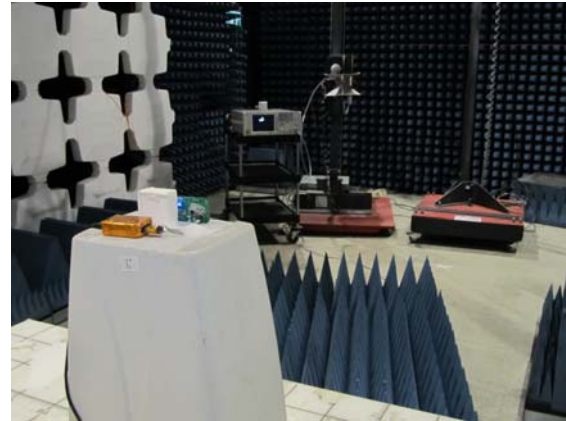

Photo 2.



Photo 3.

**Test report No: 9612335876****Page 28 of 28 Pages****Title: Transceiver Module****Model: 99954735LF****FCC ID: WCH99956BT**

APPENDIX C Abbreviations and acronyms.

The following abbreviations and acronyms are applicable to this test report:

AC	alternating current
cm	centimeter
dB	decibel
dBm	decibel referred to one milliwatt
dB(μ V)	decibel referred to one microvolt
dB(μ V/m)	decibel referred to one microvolt per meter
EBW	emission bandwidth.
EMC	electromagnetic compatibility
EUT	equipment under test
GHz	gigahertz
H	height
Hz	hertz
kHz	kilohertz
L	length
LNA	low noise amplifier
m	meter
Mbps	megabit per second
MHz	megahertz
NA	not applicable
OFDM	Orthogonal Frequency Division Multiple Access
PRBS	pseudo random binary sequence
QP	quasi-peak
RF	radio frequency
RE	radiated emission
SA	spectrum analyzer
rms	root mean square
W	width