



Report No.: E01A22030472F00501

1 of 78

**ELECTROMAGNETIC EMISSIONS COMPLIANCE REPORT
INTENTIONAL RADIATOR CERTIFICATION TO
FCC PART 15 SUBPART C REQUIREMENT**

OF

Wireless Bluetooth Home Speaker

Model No.: WB-386, DOSS TV Soundbar

Trademark: N/A

FCC ID: WC2-WB386

Report No.: E01A22030472F00501

Issue Date: Mar. 31, 2022

Prepared for

Wonders Technology Co., Ltd.

**4/F, Tower A, 3rd Building, Tian'an Cloud Park, Bantian Avenue, Longgang
District, Shenzhen, China**

Prepared by

Dong Guan Anci Electronic Technology Co., Ltd.

**1-2 Floor, Building A, No.11, Headquarters 2 Road, Songshan, Lake Hi-tech
Industrial Development Zone, Dongguan City, evelopment Zone,
Dongguan City, Guangdong Pr., China.**

**This report shall not be reproduced, except in full, without the written approval of
Dong Guan Anci Electronic Technology Co., Ltd.**



VERIFICATION OF COMPLIANCE

| | |
|----------------------|---|
| Applicant: | Wonders Technology Co., Ltd. 4/F, Tower A, 3rd Building, Tian'an Cloud Park, Bantian Avenue, Longgang District, Shenzhen, China |
| Manufacturer: | Wonders Technology Co., Ltd. 4/F, Tower A, 3rd Building, Tian'an Cloud Park, Bantian Avenue, Longgang District, Shenzhen, China |
| Product Description: | Wireless Bluetooth Home Speaker |
| Trade Mark: | N/A |
| Model Number: | WB-386, DOSS TV Soundbar (Note: All models are the same, except the model name.) |

We hereby certify that:

The above equipment was tested by Dong Guan Anci Electronic Technology Co., Ltd. The test data, data evaluation, test procedures, and equipment configurations shown in this report were made in accordance with the procedures given in ANSI C63.10-2013 and the energy emitted by the sample EUT tested as described in this report is in compliance with conducted and radiated emission limits of FCC Rules Part 15.247(2020).

Date of Test : Mar. 21, 2022 to Mar. 30, 2022

Prepared by : 
Tomas Yang/Supervisor

Reviewer &
Authorized Signer : 
Alan He/Manager





Modified Information

| Version | Summary | Revision Date | Report No. |
|---------|-----------------|---------------|--------------------|
| Ver.1.0 | Original Report | / | E01A22030472F00501 |
| | | | |
| | | | |
| | | | |
| | | | |
| | | | |
| | | | |

Table of Contents

| | | |
|-----------|--|-----------|
| 1. | GENERAL INFORMATION | 6 |
| 1.1 | PRODUCT DESCRIPTION | 6 |
| 1.2 | TEST METHODOLOGY..... | 6 |
| 1.3 | TEST FACILITY | 7 |
| 2. | SYSTEM TEST CONFIGURATION | 8 |
| 2.1 | EUT CONFIGURATION | 8 |
| 2.2 | EUT EXERCISE | 8 |
| 2.3 | TEST PROCEDURE..... | 8 |
| 2.4 | CONFIGURATION OF TESTED SYSTEM | 9 |
| 3. | SUMMARY OF TEST RESULTS | 10 |
| 4. | DESCRIPTION OF TEST MODES | 11 |
| 5. | TEST SYSTEM UNCERTAINTY | 12 |
| 6. | CONDUCTED EMISSIONS TEST | 13 |
| 6.1 | MEASUREMENT PROCEDURE: | 13 |
| 6.2 | TEST SET-UP (BLOCK DIAGRAM OF CONFIGURATION) | 13 |
| 6.3 | MEASUREMENT EQUIPMENT USED: | 13 |
| 6.4 | MEASUREMENT RESULT:..... | 13 |
| | CONDUCTED MEASUREMENT PHOTOS: | 15 |
| 6.5 | CONDUCTED MEASUREMENT PHOTOS:..... | 16 |
| 7. | RADIATED EMISSION TEST | 17 |
| 7.1 | MEASUREMENT PROCEDURE..... | 17 |
| 7.2 | TEST SET-UP (BLOCK DIAGRAM OF CONFIGURATION) | 19 |
| 7.3 | MEASUREMENT EQUIPMENT USED:..... | 20 |
| 7.4 | RADIATED EMISSION LIMIT | 21 |
| 7.5 | MEASUREMENT RESULT..... | 22 |
| 7.5 | RADIATED MEASUREMENT PHOTOS:..... | 30 |
| 8. | CHANNEL SEPARATION TEST | 31 |
| 8.1 | MEASUREMENT PROCEDURE..... | 31 |
| 8.2 | TEST SET-UP (BLOCK DIAGRAM OF CONFIGURATION) | 31 |
| 8.3 | MEASUREMENT EQUIPMENT USED:..... | 31 |
| 8.4 | MEASUREMENT RESULTS: | 31 |
| 9. | 20DB BANDWIDTH TEST | 38 |
| 9.1 | MEASUREMENT PROCEDURE..... | 38 |
| 9.2 | TEST SET-UP (BLOCK DIAGRAM OF CONFIGURATION) | 38 |
| 9.3 | MEASUREMENT EQUIPMENT USED:..... | 38 |
| 9.4 | MEASUREMENT RESULTS:..... | 38 |



- 10. QUANTITY OF HOPPING CHANNEL TEST 45**
 - 10.1 MEASUREMENT PROCEDURE 45
 - 10.2 TEST SET-UP (BLOCK DIAGRAM OF CONFIGURATION) 45
 - 10.3 MEASUREMENT EQUIPMENT USED: 45
 - 10.4 MEASUREMENT RESULTS: 45
- 11. TIME OF OCCUPANCY (DWELL TIME) TEST 46**
 - 11.1 TEST DESCRIPTION 46
 - 11.2 TEST SET-UP (BLOCK DIAGRAM OF CONFIGURATION) 46
 - 11.3 MEASUREMENT EQUIPMENT USED: 46
 - 11.4 TEST REQUIREMENTS / LIMITS 46
 - 11.5 TEST RESULT 47
- 12. MAXIMUM PEAK OUTPUT POWER TEST 49**
 - 12.1 MEASUREMENT PROCEDURE 49
 - 12.2 TEST SET-UP (BLOCK DIAGRAM OF CONFIGURATION) 49
 - 12.3 MEASUREMENT EQUIPMENT USED: 49
 - 12.4 MEASUREMENT RESULTS: 50
- 13. BAND EDGE TEST 56**
 - 13.1 MEASUREMENT PROCEDURE 56
 - 13.2 TEST SET-UP (BLOCK DIAGRAM OF CONFIGURATION) 57
 - 13.3 MEASUREMENT EQUIPMENT USED: 57
 - 13.4 MEASUREMENT RESULTS: 58
- 14. ANTENNA APPLICATION 73**
 - 14.1 ANTENNA REQUIREMENT 73
 - 14.2 RESULT 73



1. GENERAL INFORMATION

1.1 Product Description

| Characteristics | Description |
|---------------------------|--|
| Product Name | Wireless Bluetooth Home Speaker |
| Model number | WB-386, DOSS TV Soundbar (Note: All models are the same, except the model name.) |
| Input rating | 18V \equiv 2A |
| Power Supply | AC 120V/60Hz for adapter |
| Kind of Device | Bluetooth Ver. 5.0 |
| Modulation | GFSK, $\pi/4$ -DQPSK, 8DPSK |
| Operating Frequency Range | 2402-2480MHz |
| Number of Channels | 79 |
| Transmit Power Max(PK) | 2.27dBm(0.0017W) |
| Antenna Type | Internal PCB antenna |
| Antenna Gain | 0dBi |

1.2 Test Methodology

Both conducted and radiated testing was performed according to the procedures in ANSI C63.10-2013. Radiated testing was performed at an antenna to EUT distance 3 meters.



1.3 Test Facility

Site Description

EMC Lab. : Accredited by CNAS, 2017.06.26
The certificate is valid until 2022.10.28
The Laboratory has been assessed and proved to be in compliance with CNAS-CL01:2006 (identical to ISO/IEC 17025:2005)
The Certificate Registration Number is L0468.

Accredited by A2LA, 2018.03.15
The Certificate Number is 4422.01.

Name of Firm : Dong Guan Anci Electronic Technology Co., Ltd.
Site Location : 1-2 Floor, Building A, No.11, Headquarters 2 Road, Songshan, Lake Hi-tech Industrial Development Zone, Dongguan City, evelopment Zone, Dongguan City, Guangdong Pr., China.

2. System Test Configuration

2.1 EUT Configuration

The EUT configuration for testing is installed on RF field strength measurement to meet the Commissions requirement and operating in a manner which intends to maximize its emission characteristics in a continuous normal application.

2.2 EUT Exercise

The Transmitter was operated in the normal operating mode. The Tx frequency was fixed which was for the purpose of the measurements.

2.3 Test Procedure

2.3.1 Conducted Emissions

The EUT is placed on a turn table which is 0.8 m above ground plane. According to the requirements in Section 13.1.4.1 of ANSI C63.10-2013. Conducted emissions from the EUT measured in the frequency range between 0.15 MHz and 30MHz using CISPR Quasi-Peak and average detector mode.

2.3.2 Radiated Emissions

Below 1000MHz, The EUT was placed on a turn table which is 0.8m above ground plane. And above 1000MHz, The EUT was placed on a styrofoam table which is 1.5m above ground plane. The turn table shall rotate 360 degrees to determine the position of maximum emission level. EUT is set 3m away from the receiving antenna which varied from 1m to 4m to find out the highest emission. And also, each emission was to be maximized by changing the polarization of receiving antenna both horizontal and vertical. In order to find out the max. emission, the relative positions of EUT was fixed in a particular direction according to the requirements in Section 13.1.4.1 of ANSI C63.10-2013.

2.4 Configuration of Tested System

Fig. 2-1 Configuration of Tested System



Table 2-1 Equipment Used in Tested System

| Item | Equipment | Trademark | Model No. | FCC ID | Note |
|------|---------------------------------|-----------|--|-----------|---------------------------------|
| 1. | Wireless Bluetooth Home Speaker | N/A | WB-386 | WC2-WB386 | <i>EUT</i> |
| 2. | Adapter | N/A | Model:R361-1802000U Input: 100-240V~, 50/60Hz 1.5A Output: 18V $\overline{=}$ 2A | N/A | <i>Support Equipment</i> |

Note:

- (1) Unless otherwise denoted as EUT in 『Remark』 column , device(s) used in tested system is a support equipment.

3. Summary of Test Results

| FCC Rules | Description Of Test | Result |
|--------------------|-------------------------------|-----------|
| §15.207 | AC Power Conducted Emission | Compliant |
| §15.247(d),§15.209 | Radiated Emission | Compliant |
| §15.247(a)(1) | Channel Separation test | Compliant |
| §15.247(a)(1) | 20dB Bandwidth | Compliant |
| §15.247(a)(1)(iii) | Quantity of Hopping Channel | Compliant |
| §15.247(a)(1)(iii) | Time of Occupancy(Dwell Time) | Compliant |
| §15.247(b) | Max Peak output Power test | Compliant |
| §15.247(d) | Band edge test | Compliant |
| §15.203 | Antenna Requirement | Compliant |

Remark: The product was tested under the battery fully charged.

Note 1: During the charging proceed, the Bluetooth function of this device is inactive.

Note 2: Left and right earbuds have the same RF module and antenna, schematics, PCB Layout and component, Here right earbud was selected for related conducted tests. And for the radiated test, both earbuds are under the test. Right earbud acts as a master device and left earbud acts as a slave device.

4. Description of test modes

The EUT has been tested under its typical operating condition for EUT tested alone. Pre-defined engineering program for regulatory testing used to control the EUT for staying in continuous transmitting. Only the worst case data were reported.

The EUT has been associated with peripherals pursuant to ANSI C63.10-2013 and configuration operated in a manner tended to maximize its emission characteristics in a typical application. Frequency range investigated: radiation (9 KHz to the 10th harmonics of the highest fundamental frequency or to 40 GHz, whichever is lower).

For Radiated: The EUT’s antenna was pre-tested under the following modes:

| Test Mode | Description |
|---------------|-----------------|
| Mode A | X-Y axis |
| Mode B | Y-Z axis |
| Mode C | X-Z axis |

From the above modes, the worst case was found in Mode C. Therefore only the test data of the mode was recorded in this report.

The EUT has been tested under TX operating condition.

This EUT is a FHSS system, were conducted to determine the final configuration from all possible combinations. We use software control the EUT, Let EUT hopping on and transmit with highest power, all the modes GFSK, $\pi/4$ -DQPSK, 8DPSK have been tested. 79 Channels are provided by EUT. The 3 channels of lower, medium and higher were chosen for test.

| Channel | Frequency(MHz) |
|---------|----------------|
| 1 | 2402 |
| 40 | 2441 |
| 79 | 2480 |

5. TEST SYSTEM UNCERTAINTY

The following measurement uncertainty levels have been estimated for tests performed on the apparatus:

| Parameter | Uncertainty |
|--------------------------------|-------------------------|
| Radio Frequency | $\pm 1 \times 10^{-5}$ |
| Maximum Peak Output Power Test | $\pm 1.0\text{dB}$ |
| Conducted Emissions Test | $\pm 2.0\text{dB}$ |
| Radiated Emission Test | $\pm 2.0\text{dB}$ |
| Power Density | $\pm 2.0\text{dB}$ |
| Occupied Bandwidth Test | $\pm 1.0\text{dB}$ |
| Band Edge Test | $\pm 3\text{dB}$ |
| All emission, radiated | $\pm 3\text{dB}$ |
| Antenna Port Emission | $\pm 3\text{dB}$ |
| Temperature | $\pm 0.5^\circ\text{C}$ |
| Humidity | $\pm 3\%$ |

Remark: The coverage Factor ($k=2$), and measurement Uncertainty for a level of Confidence of 95%

Please refer to the following data.

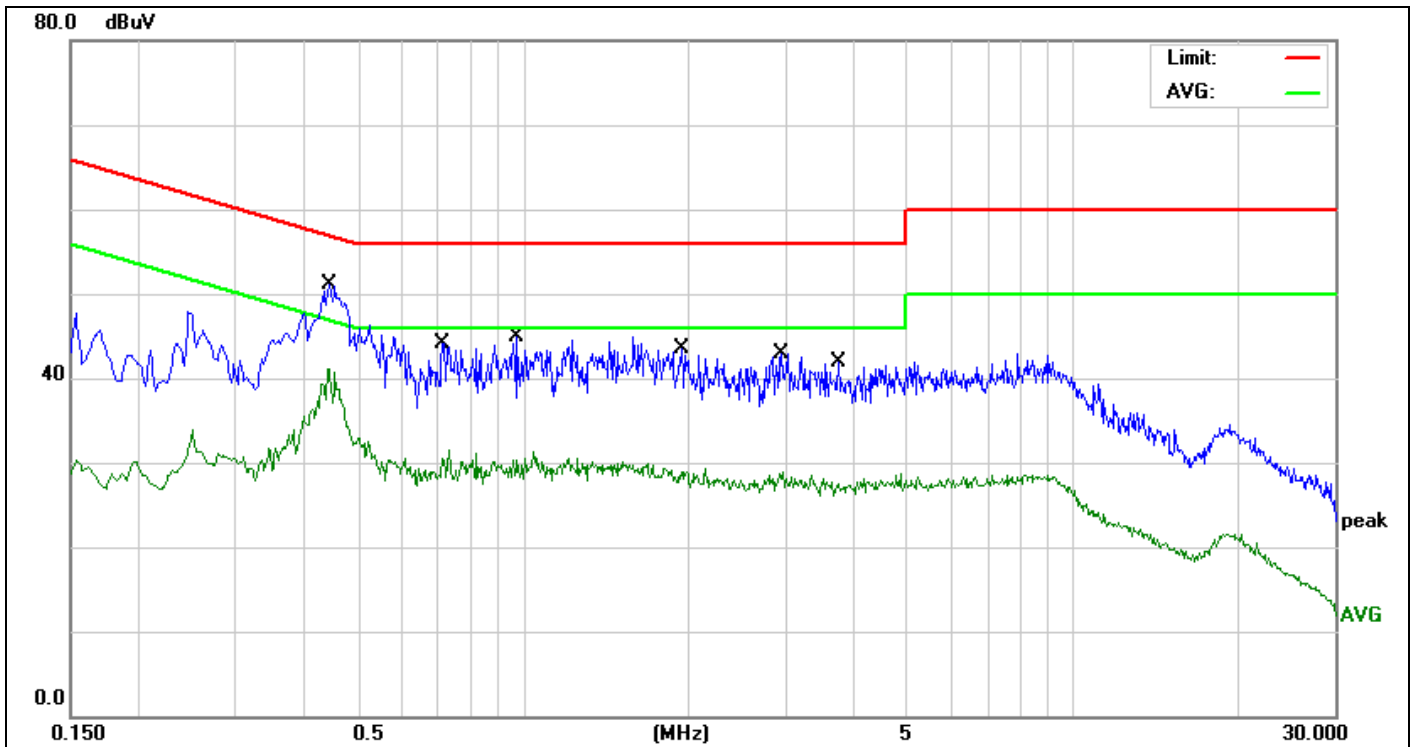

| | | | |
|--------|---------------------------------|----------------|----------------------|
| Site: | 843 | Phase:L1 | Temperature(C):24(C) |
| Limit: | FCC Part 15 C Conduction(QP) | | Humidity(%):58% |
| EUT: | Wireless Bluetooth Home Speaker | Test Time: | Mar. 23, 2022 |
| M/N.: | WB-386 | Power Rating: | AC 120V/60Hz |
| Mode: | TX2480 | Test Engineer: | Jack |
| Note: | | | |

| No. | Frequency (MHz) | Reading Level(dBuV) | Factor (dB) | Measurement(dBuV) | Limit (dBuV) | Over (dB) | Detector | Comment |
|-----|-----------------|---------------------|-------------|-------------------|--------------|-----------|----------|---------|
| 1 | 0.4460 | 38.56 | 9.77 | 48.33 | 56.95 | -8.62 | QP | |
| 2 * | 0.4460 | 29.71 | 9.77 | 39.48 | 46.95 | -7.47 | AVG | |
| 3 | 0.7140 | 28.60 | 9.58 | 38.18 | 56.00 | -17.82 | QP | |
| 4 | 0.7140 | 19.29 | 9.58 | 28.87 | 46.00 | -17.13 | AVG | |
| 5 | 0.9740 | 27.87 | 9.91 | 37.78 | 56.00 | -18.22 | QP | |
| 6 | 0.9740 | 18.87 | 9.91 | 28.78 | 46.00 | -17.22 | AVG | |
| 7 | 1.9420 | 26.21 | 9.80 | 36.01 | 56.00 | -19.99 | QP | |
| 8 | 1.9420 | 17.67 | 9.80 | 27.47 | 46.00 | -18.53 | AVG | |
| 9 | 2.9580 | 25.62 | 10.01 | 35.63 | 56.00 | -20.37 | QP | |
| 10 | 2.9580 | 17.43 | 10.01 | 27.44 | 46.00 | -18.56 | AVG | |
| 11 | 3.7420 | 25.29 | 9.78 | 35.07 | 56.00 | -20.93 | QP | |
| 12 | 3.7420 | 17.11 | 9.78 | 26.89 | 46.00 | -19.11 | AVG | |

*:Maximum data x:Over limit !:over margin

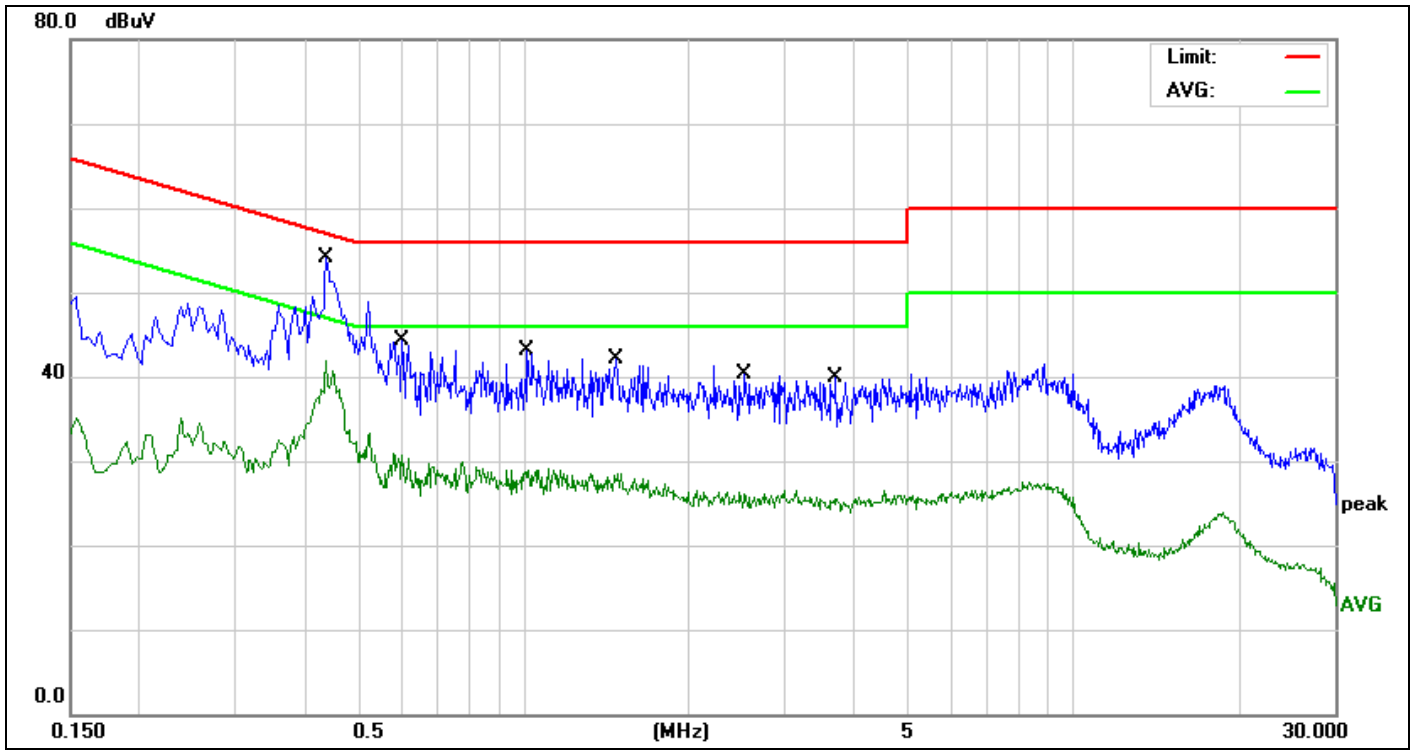

| | | | | | |
|--------|---------------------------------|----------------|---------------|-----------------|-------|
| Site: | 843 | Phase: | N | Temperature(C): | 24(C) |
| Limit: | FCC Part 15 C Conduction(QP) | Test Time: | Mar. 23, 2022 | Humidity(%): | 58% |
| EUT: | Wireless Bluetooth Home Speaker | Power Rating: | AC 120V/60Hz | | |
| M/N.: | WB-386 | Test Engineer: | Jack | | |
| Mode: | TX2480 | | | | |
| Note: | | | | | |

| No. | Frequency (MHz) | Reading Level(dBuV) | Factor (dB) | Measurement(dBuV) | Limit (dBuV) | Over (dB) | Detector | Comment |
|-----|-----------------|---------------------|-------------|-------------------|--------------|-----------|----------|---------|
| 1 | 0.4380 | 40.11 | 9.78 | 49.89 | 57.10 | -7.21 | QP | |
| 2 * | 0.4380 | 30.21 | 9.78 | 39.99 | 47.10 | -7.11 | AVG | |
| 3 | 0.6020 | 30.77 | 9.56 | 40.33 | 56.00 | -15.67 | QP | |
| 4 | 0.6020 | 19.65 | 9.56 | 29.21 | 46.00 | -16.79 | AVG | |
| 5 | 1.0180 | 26.05 | 9.93 | 35.98 | 56.00 | -20.02 | QP | |
| 6 | 1.0180 | 17.98 | 9.93 | 27.91 | 46.00 | -18.09 | AVG | |
| 7 | 1.4740 | 25.99 | 9.96 | 35.95 | 56.00 | -20.05 | QP | |
| 8 | 1.4740 | 17.57 | 9.96 | 27.53 | 46.00 | -18.47 | AVG | |
| 9 | 2.5340 | 22.33 | 9.89 | 32.22 | 56.00 | -23.78 | QP | |
| 10 | 2.5340 | 14.85 | 9.89 | 24.74 | 46.00 | -21.26 | AVG | |
| 11 | 3.7100 | 21.86 | 9.79 | 31.65 | 56.00 | -24.35 | QP | |
| 12 | 3.7100 | 14.52 | 9.79 | 24.31 | 46.00 | -21.69 | AVG | |

*:Maximum data x:Over limit !:over margin

6.5 Conducted Measurement Photos:



7. Radiated Emission Test

7.1 Measurement Procedure

1. The testing follows the guidelines in Spurious Radiated Emissions of ANSI C63.10-2013.
2. Below 1000MHz, The EUT was placed on a turn table which is 0.8m above ground plane. And above 1000MHz, The EUT was placed on a styrofoam table which is 1.5m above ground plane.
3. The EUT was set 3 meters from the interference receiving antenna, which was mounted on the top of a variable height antenna tower.
4. For each suspected emission, the EUT was arranged to its worst case and then tune the Antenna tower (From 1m to 4m) and turntable (from 0 degree to 360 degree) to find the maximum reading. A pre-amp and a high pass filter are used for the test in order to get better signal level to comply with the guidelines.
5. Set to the maximum power setting and enable the EUT transmit continuously.
6. Final measurement (Above 1GHz): The frequency range will be divided into different sub ranges depending of the frequency range of the used horn antenna. The EMI Receiver set to peak and average mode and a resolution bandwidth of 1MHz. The measurement will be performed in horizontal and vertical polarization of the measuring antenna and while rotating the EUT in its vertical axis in the range of 0 degree to 360 degree in order to have the antenna inside the cone of radiation.
7. Test Procedure of measurement (For Above 1GHz):
 - 1) Monitor the frequency range at horizontal polarization and move the antenna over all sides of the EUT(if necessary move the EUT to another orthogonal axis).
 - 2) Change the antenna polarization and repeat 1) with vertical polarization.
 - 3) Make a hardcopy of the spectrum.
 - 4) Measure the frequency of the detected emissions with a lower span and resolution bandwidth to increase the accuracy and note the frequency value.
 - 5) Change the analyser mode to Clear/ Write and found the cone of emission.
 - 6) Rotate and move the EUT, so that the measuring distance can be enlarged to 3m and the antenna will be still inside the cone of emission.
 - 7) Measure the level of the detected frequency with the correct resolution bandwidth, with the antenna polarization and azimuth and the peak and average detector, which causes the maximum emission.
 - 8) Repeat steps 1) to 7) for the next antenna spot if the EUT is larger than the antenna beamwidth.

Use the following spectrum analyzer settings:

When spectrum scanned from 30MHz to 1GHz setting resolution bandwidth 120KHz and video bandwidth 300KHz:

| EMI Test Receiver | Setting |
|-------------------|----------|
| Attenuation | Auto |
| RB | 120KHz |
| VB | 300KHz |
| Detector | QP |
| Trace | Max hold |

When spectrum scanned above 1GHz setting resolution bandwidth 1MHz, video bandwidth 3MHz:

| EMI Test Receiver | Setting |
|-------------------|----------|
| Attenuation | Auto |
| RB | 1MHz |
| VB | 3MHz |
| Detector | Peak |
| Trace | Max hold |

When spectrum scanned above 1GHz setting resolution bandwidth 1MHz, video bandwidth 10Hz:

| EMI Test Receiver | Setting |
|-------------------|----------|
| Attenuation | Auto |
| RB | 1MHz |
| VB | 10Hz |
| Detector | Average |
| Trace | Max hold |

7.2 Test SET-UP (Block Diagram of Configuration)

(A) Radiated Emission Test Set-Up, Frequency Below 30MHz

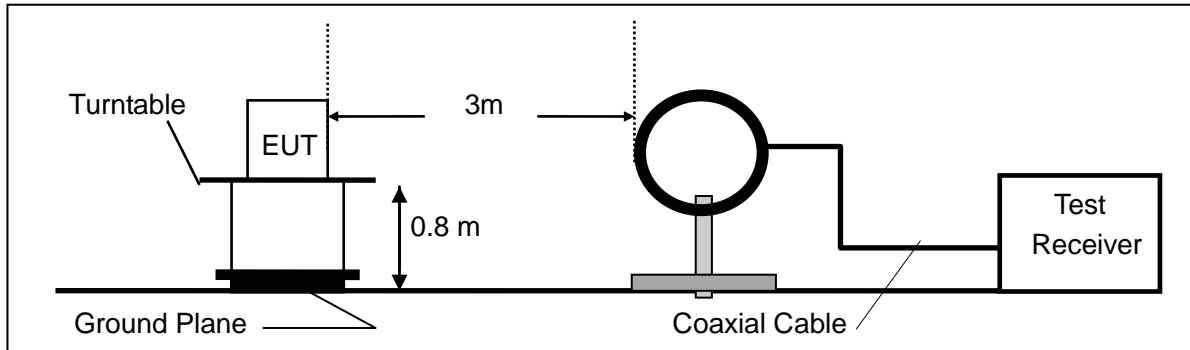

(B) Radiated Emission Test Set-Up, Frequency Below 1000MHz

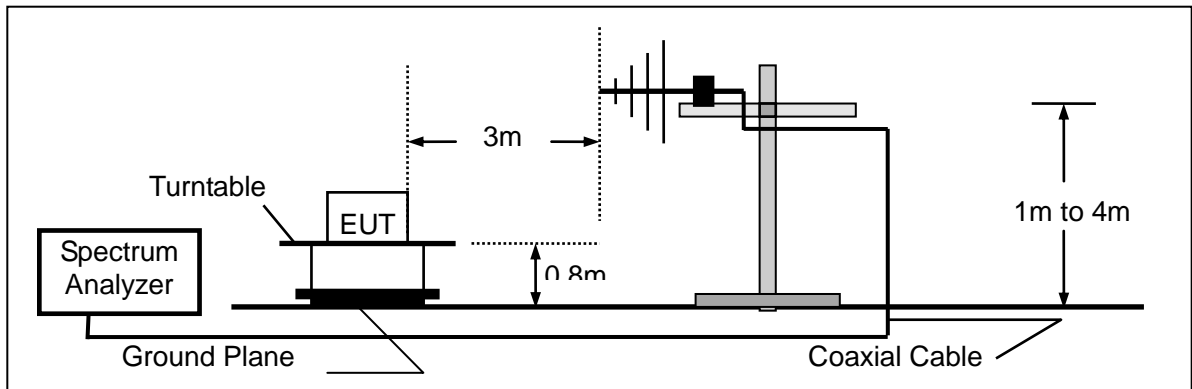

(C) Radiated Emission Test Set-Up, Frequency above 1000MHz

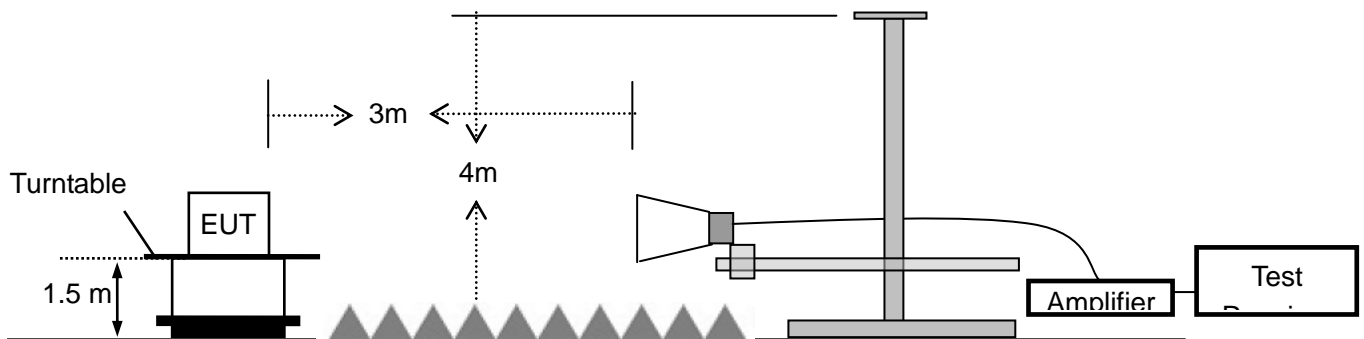

7.3 Measurement Equipment Used:

| Item | Equipment | Manufacturer | Model No. | Serial No. | Calibrated until |
|------|------------------------------|--------------------|--------------------------|--------------------|------------------|
| | EMI Test Receiver | Rohde & Schwarz | ESPI | 100502 | 2022-11-11 |
| | Pre-Amplifier | HP | 8447D | 2727A06172 | 2022-05-17 |
| | Bilog Antenna | Schwarzbeck | VULB9163 | VULB9163-588 | 2022-05-17 |
| | Loop Antenna | Schwarzbeck | FMZB 1516 | 1516-141 | 2022-05-20 |
| | Spectrum Analyzer | Rohde & Schwarz | FSV40 | US40240623 | 2022-05-20 |
| | Low noise Amplifiers | A-INFO | LA1018N4009 | J101313052400 1 | 2022-05-17 |
| | Horn antenna | A-INFO | LB-10180-SF | J203109061212 3 | 2022-05-17 |
| | Broadband RF Power Amplifier | AEROFLEX | AEROFLEX10 0KHz-40GHz | J101313052400 1 | 2022-05-20 |
| | DRG Horn Antenna | A.H.SYSTEMS | SAS-574 | J203109061212 3 | 2022-05-20 |
| | RF Cable | Gigalink Microwave | ZT40-2.92J-2.92J-2m | N/A | 2022-05-20 |
| | RF Cable | Gigalink Microwave | ZT40-2.92J-2.92J-0.3m | N/A | 2022-05-20 |
| | RF Cable | N/A | N/A | 6# | 2022-05-17 |
| | RF Cable | N/A | N/A | 1-1# | 2022-05-17 |
| | RF Cable | N/A | N/A | 1-2# | 2022-05-17 |
| | RF Cable | N/A | N/A | 7# | 2022-05-17 |
| | 3m Semi-anechoic Chamber | chengyu | 9m*6m*6m | N/A | 2022-05-17 |
| | Test Software | Farad | EZ-EMC Ver:ANCI-3A1 | N/A | N/A |

7.4 Radiated Emission Limit

The emissions from an intentional radiator shall not exceed the field strength levels specified in the following table 15.209(a):

| Frequencies (MHz) | Field Strength (micorvolts/meter) | Measurement Distance (meters) |
|-------------------|-----------------------------------|-------------------------------|
| 0.009~0.490 | 2400/F(KHz) | 300 |
| 0.490~1.705 | 24000/F(KHz) | 30 |
| 1.705~30.0 | 30 | 30 |
| 30~88 | 100 | 3 |
| 88~216 | 150 | 3 |
| 216~960 | 200 | 3 |
| Above 960 | 500 | 3 |

15.205 Restricted bands of operation

| MHz | MHz | MHz | GHz |
|----------------------------|-----------------------|-----------------|------------------|
| 0.090 - 0.110 | 16.42 - 16.423 | 399.9 - 410 | 4.5 - 5.15 |
| ¹ 0.495 - 0.505 | 16.69475 - 16.69525 | 608 - 614 | 5.35 - 5.46 |
| 2.1735 - 2.1905 | 16.80425 - 16.80475 | 960 - 1240 | 7.25 - 7.75 |
| 4.125 - 4.128 | 25.5 - 25.67 | 1300 - 1427 | 8.025 - 8.5 |
| 4.17725 - 4.17775 | 37.5 - 38.25 | 1435 - 1626.5 | 9.0 - 9.2 |
| 4.20725 - 4.20775 | 73 - 74.6 | 1645.5 - 1646.5 | 9.3 - 9.5 |
| 6.215 - 6.218 | 74.8 - 75.2 | 1660 - 1710 | 10.6 - 12.7 |
| 6.26775 - 6.26825 | 108 - 121.94 | 1718.8 - 1722.2 | 13.25 - 13.4 |
| 6.31175 - 6.31225 | 123 - 138 | 2200 - 2300 | 14.47 - 14.5 |
| 8.291 - 8.294 | 149.9 - 150.05 | 2310 - 2390 | 15.35 - 16.2 |
| 8.362 - 8.366 | 156.52475 - 156.52525 | 2483.5 - 2500 | 17.7 - 21.4 |
| 8.37625 - 8.38675 | 156.7 - 156.9 | 2690 - 2900 | 22.01 - 23.12 |
| 8.41425 - 8.41475 | 162.0125 - 167.17 | 3260 - 3267 | 23.6 - 24.0 |
| 12.29 - 12.293 | 167.72 - 173.2 | 3332 - 3339 | 31.2 - 31.8 |
| 12.51975 - 12.52025 | 240 - 285 | 3345.8 - 3358 | 36.43 - 36.5 |
| 12.57675 - 12.57725 | 322 - 335.4 | 3600 - 4400 | (²) |

- Remark 1. Emission level in dBuV/m=20 log (uV/m)
- :
2. Measurement was performed at an antenna to the closed point of EUT distance of meters.
 3. Only spurious frequency is permitted to locate within the Restricted Bands specified in provision of § 15.205, and the emissions located in restricted bands also comply with 15.209 limit.



7.5 Measurement Result

| | | | |
|--------------------|------|---------------|------------|
| Operation Mode: | TX | Test Date : | 2022-03-23 |
| Test By: | Best | Temperature : | 25°C |
| Test Result: | PASS | Humidity : | 58 % |
| Measured Distance: | 3m | | |

Below 30MHz:

| Freq. (MHz) | Ant.Pol. H/V | Emission Level (dBuV/m) | Limit 3m (dBuV/m) | Over (dB) |
|----------------|-----------------|-------------------------------|----------------------|--------------|
| -- | -- | -- | -- | -- |

Note: The low frequency, which started from 9KHz-30MHz, was pre-scanned and the result which was 20dB lower than the limit line per 15.31(o) was not reported.

Below 1000MHz:

Pass.

All the modulation modes were tested the data of the worst mode (GFSK TX 2480MHz) are recorded in the following pages and the others modulation methods do not exceed the limits.

Please refer to the following data.

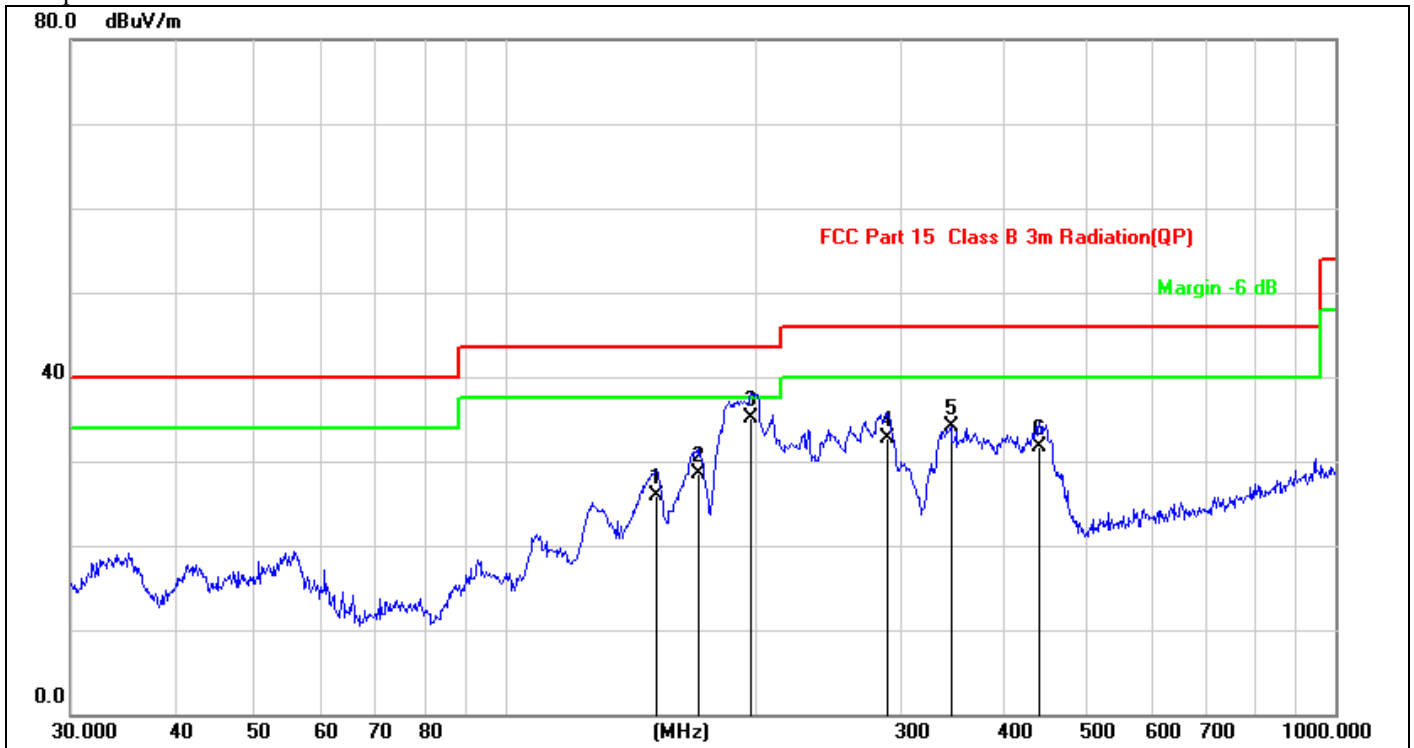

| | | | | | |
|--------|---------------------------------|---------------|--------------|-----------------|-------|
| Site: | LAB | Antenna:: | Horizontal | Temperature(C): | 26(C) |
| Limit: | FCC Part 15 C 3m Radiation | Test Time: | 2022-03-23 | Humidity(%): | 60% |
| EUT: | Wireless Bluetooth Home Speaker | Power Rating: | AC 120V/60Hz | Test Engineer: | Bast |
| M/N.: | WB-386 | | | | |
| Mode: | TX2480 | | | | |
| Note: | | | | | |

| No. | Frequency (MHz) | Reading (dBuV) | Factor (dB/m) | Level (dBuV/m) | Limit (dBuV/m) | Margin (dB) | Det. | Remark |
|-----|-----------------|----------------|---------------|----------------|----------------|-------------|------|--------|
| 1 | 152.1297 | 40.50 | -14.66 | 25.84 | 43.50 | -17.66 | QP | |
| 2 | 170.7926 | 41.73 | -13.29 | 28.44 | 43.50 | -15.06 | QP | |
| 3 * | 197.8928 | 46.25 | -11.09 | 35.16 | 43.50 | -8.34 | QP | |
| 4 | 289.0021 | 42.08 | -9.33 | 32.75 | 46.00 | -13.25 | QP | |
| 5 | 344.3855 | 42.09 | -8.08 | 34.01 | 46.00 | -11.99 | QP | |
| 6 | 440.1963 | 37.80 | -6.16 | 31.64 | 46.00 | -14.36 | QP | |

*:Maximum data x:Over limit !:over margin

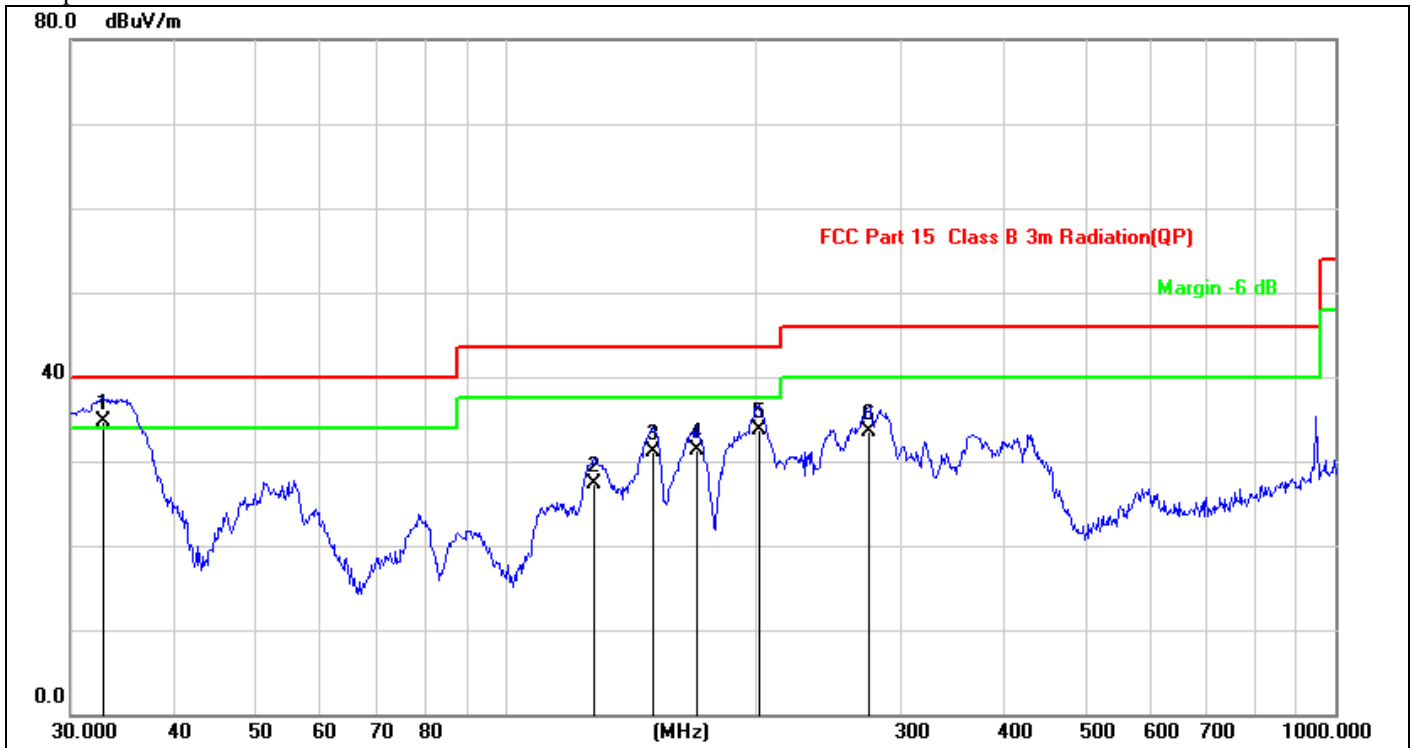

| | | | | | |
|---------------|---------------------------------|-----------------------|----------|------------------------|-------|
| Site: | LAB | Antenna:: | Vertical | Temperature(C): | 26(C) |
| Limit: | FCC Part 15 C 3m Radiation | | | Humidity(%): | 60% |
| EUT: | Wireless Bluetooth Home Speaker | Test Time: | | 2022-03-23 | |
| M/N.: | WB-386 | Power Rating: | | AC 120V/60Hz | |
| Mode: | TX2480 | Test Engineer: | | Bast | |
| Note: | | | | | |

| No. | Frequency (MHz) | Reading (dBuV) | Factor (dB/m) | Level (dBuV/m) | Limit (dBuV/m) | Margin (dB) | Det. | Remark |
|-----|-----------------|----------------|---------------|----------------|----------------|-------------|------|--------|
| 1 * | 32.8637 | 48.92 | -14.27 | 34.65 | 40.00 | -5.35 | QP | |
| 2 | 128.1130 | 41.43 | -14.13 | 27.30 | 43.50 | -16.20 | QP | |
| 3 | 151.0666 | 45.85 | -14.70 | 31.15 | 43.50 | -12.35 | QP | |
| 4 | 170.1948 | 44.59 | -13.36 | 31.23 | 43.50 | -12.27 | QP | |
| 5 | 202.1005 | 44.62 | -10.97 | 33.65 | 43.50 | -9.85 | QP | |
| 6 | 274.1939 | 43.16 | -9.61 | 33.55 | 46.00 | -12.45 | QP | |

*:Maximum data x:Over limit !:over margin

**Above 1000MHz~10th Harmonics:**

Please refer to the following data.

Operation Mode: GFSK (CH1: 2402MHz) Test Date : 2022-03-23

| Freq. (MHz) | Ant. Pol. | Reading Level(dBuV/m) | | Correct Factor dB | Emission Level(dBuV/m) | | Limit 3m(dBuV/m) | | Margin(dB) | |
|----------------|--------------|--------------------------|-------|-------------------------|---------------------------|-------|---------------------|----|------------|--------|
| | | PK | AV | | PK | AV | PK | AV | PK | AV |
| 4804 | V | 95.35 | 76.15 | -32.3 | 63.05 | 43.85 | 74 | 54 | -10.95 | -10.15 |
| 7206 | V | 97.39 | 77.4 | -37.25 | 60.14 | 40.15 | 74 | 54 | -13.86 | -13.85 |
| 9608 | V | 98.12 | 79.42 | -39.8 | 58.32 | 39.62 | 74 | 54 | -15.68 | -14.38 |
| 12010 | V | 97.82 | 79.15 | -40.5 | 57.32 | 38.65 | 74 | 54 | -16.68 | -15.35 |
| 14412 | V | 98.03 | 78.88 | -41.7 | 56.33 | 37.18 | 74 | 54 | -17.67 | -16.82 |
| 16814 | V | 95.17 | 76.58 | -40 | 55.17 | 36.58 | 74 | 54 | -18.83 | -17.42 |
| 4804 | H | 94.38 | 74.98 | -31.4 | 62.98 | 43.58 | 74 | 54 | -11.02 | -10.42 |
| 7206 | H | 94.86 | 75.75 | -35.5 | 59.36 | 40.25 | 74 | 54 | -14.64 | -13.75 |
| 9608 | H | 96.42 | 77.95 | -38.3 | 58.12 | 39.65 | 74 | 54 | -15.88 | -14.35 |
| 12010 | H | 96.69 | 77.74 | -39 | 57.69 | 38.74 | 74 | 54 | -16.31 | -15.26 |
| 14412 | H | 98.32 | 79.52 | -42 | 56.32 | 37.52 | 74 | 54 | -17.68 | -16.48 |
| 16814 | H | 94.77 | 76.15 | -39.3 | 55.47 | 36.85 | 74 | 54 | -18.53 | -17.15 |

Operation Mode: GFSK (CH40: 2441MHz) Test Date : 2022-03-23

| Freq. (MHz) | Ant. Pol. | Reading Level(dBuV/m) | | Correct Factor dB | Emission Level(dBuV/m) | | Limit 3m(dBuV/m) | | Margin(dB) | |
|----------------|--------------|--------------------------|-------|-------------------------|---------------------------|-------|---------------------|----|------------|--------|
| | | PK | AV | | PK | AV | PK | AV | PK | AV |
| 4882 | V | 96.04 | 76.32 | -32.3 | 63.74 | 44.02 | 74 | 54 | -10.26 | -9.98 |
| 7323 | V | 97.45 | 78.23 | -37.2 | 60.25 | 41.03 | 74 | 54 | -13.75 | -12.97 |
| 9764 | V | 98.76 | 79.96 | -39.6 | 59.16 | 40.36 | 74 | 54 | -14.84 | -13.64 |
| 12205 | V | 98.16 | 78.97 | -40.5 | 57.66 | 38.47 | 74 | 54 | -16.34 | -15.53 |
| 14646 | V | 97.25 | 78.65 | -41 | 56.25 | 37.65 | 74 | 54 | -17.75 | -16.35 |
| 17087 | V | 96.24 | 77.68 | -41.1 | 55.14 | 36.58 | 74 | 54 | -18.86 | -17.42 |
| 4882 | H | 95.16 | 75.29 | -31.6 | 63.56 | 43.69 | 74 | 54 | -10.44 | -10.31 |
| 7323 | H | 95.96 | 76.92 | -35.7 | 60.26 | 41.22 | 74 | 54 | -13.74 | -12.78 |
| 9764 | H | 97.66 | 78.45 | -38.3 | 59.36 | 40.15 | 74 | 54 | -14.64 | -13.85 |
| 12205 | H | 96.32 | 77.69 | -39 | 57.32 | 38.69 | 74 | 54 | -16.68 | -15.31 |
| 14646 | H | 98.31 | 79.25 | -42 | 56.31 | 37.25 | 74 | 54 | -17.69 | -16.75 |
| 17087 | H | 96.69 | 78.08 | -41.5 | 55.19 | 36.58 | 74 | 54 | -18.81 | -17.42 |



Operation Mode: GFSK (CH79: 2480MHz) Test Date : 2022-03-23

| Freq. (MHz) | Ant. Pol. H/V | Reading Level(dBuV/m) | | Correct Factor dB | Emission Level(dBuV/m) | | Limit 3m(dBuV/m) | | Margin(dB) | |
|----------------|---------------------|--------------------------|-------|-------------------------|---------------------------|-------|---------------------|----|------------|--------|
| | | PK | AV | | PK | AV | PK | AV | PK | AV |
| 4960 | V | 96.53 | 77.5 | -32.3 | 64.23 | 45.2 | 74 | 54 | -9.77 | -8.8 |
| 7440 | V | 98.59 | 79.31 | -37.2 | 61.39 | 42.11 | 74 | 54 | -12.61 | -11.89 |
| 9920 | V | 98.96 | 80.23 | -39.6 | 59.36 | 40.63 | 74 | 54 | -14.64 | -13.37 |
| 12400 | V | 98.32 | 79.22 | -40.7 | 57.62 | 38.52 | 74 | 54 | -16.38 | -15.48 |
| 14880 | V | 97.33 | 78.19 | -41 | 56.33 | 37.19 | 74 | 54 | -17.67 | -16.81 |
| 17360 | V | 97.57 | 78.35 | -41.1 | 56.47 | 37.25 | 74 | 54 | -17.53 | -16.75 |
| 4960 | H | 96.18 | 75.96 | -31.6 | 64.58 | 44.36 | 74 | 54 | -9.42 | -9.64 |
| 7440 | H | 96.55 | 76.83 | -35.7 | 60.85 | 41.13 | 74 | 54 | -13.15 | -12.87 |
| 9920 | H | 97.13 | 78.42 | -38.1 | 59.03 | 40.32 | 74 | 54 | -14.97 | -13.68 |
| 12400 | H | 96.23 | 77.16 | -39 | 57.23 | 38.16 | 74 | 54 | -16.77 | -15.84 |
| 14880 | H | 98.32 | 79.84 | -42 | 56.32 | 37.84 | 74 | 54 | -17.68 | -16.16 |
| 17360 | H | 97.21 | 77.74 | -41.5 | 55.71 | 36.24 | 74 | 54 | -18.29 | -17.76 |

Operation Mode: Pi/4-DQPSK (CH1: 2402MHz) Test Date : 2022-03-23

| Freq. (MHz) | Ant. Pol. H/V | Reading Level(dBuV/m) | | Correct Factor dB | Emission Level(dBuV/m) | | Limit 3m(dBuV/m) | | Over(dB) | |
|----------------|---------------------|--------------------------|-------|-------------------------|---------------------------|-------|---------------------|----|----------|--------|
| | | PK | AV | | PK | AV | PK | AV | PK | AV |
| 4804 | V | 94.28 | 74.88 | -32.3 | 61.98 | 42.58 | 74 | 54 | -12.02 | -11.42 |
| 7206 | V | 97.52 | 78.47 | -37.2 | 60.32 | 41.27 | 74 | 54 | -13.68 | -12.73 |
| 9608 | V | 98.12 | 79.58 | -39.8 | 58.32 | 39.78 | 74 | 54 | -15.68 | -14.22 |
| 12010 | V | 97.08 | 77.95 | -40.5 | 56.58 | 37.45 | 74 | 54 | -17.42 | -16.55 |
| 14412 | V | 98.02 | 79.02 | -41.7 | 56.32 | 37.32 | 74 | 54 | -17.68 | -16.68 |
| 16814 | V | 96.47 | 77.56 | -40 | 56.47 | 37.56 | 74 | 54 | -17.53 | -16.44 |
| 4804 | H | 93.18 | 73.92 | -31.6 | 61.58 | 42.32 | 74 | 54 | -12.42 | -11.68 |
| 7206 | H | 95.65 | 76.86 | -35.5 | 60.15 | 41.36 | 74 | 54 | -13.85 | -12.64 |
| 9608 | H | 96.72 | 77.71 | -38.3 | 58.42 | 39.41 | 74 | 54 | -15.58 | -14.59 |
| 12010 | H | 96.92 | 77.74 | -39.4 | 57.52 | 38.34 | 74 | 54 | -16.48 | -15.66 |
| 14412 | H | 98.41 | 79.21 | -42 | 56.41 | 37.21 | 74 | 54 | -17.59 | -16.79 |
| 16814 | H | 95.33 | 76.47 | -39.3 | 56.03 | 37.17 | 74 | 54 | -17.97 | -16.83 |



| Freq. (MHz) | Ant. Pol. | Reading Level(dBuV/m) | | Correct Factor dB | Emission Level(dBuV/m) | | Limit 3m(dBuV/m) | | Over(dB) | |
|----------------|--------------|--------------------------|-------|-------------------------|---------------------------|-------|---------------------|----|----------|--------|
| | | PK | AV | | PK | AV | PK | AV | PK | AV |
| 4882 | V | 95.21 | 75.55 | -32.3 | 62.91 | 43.25 | 74 | 54 | -11.09 | -10.75 |
| 7323 | V | 97.45 | 78.85 | -37.2 | 60.25 | 41.65 | 74 | 54 | -13.75 | -12.35 |
| 9764 | V | 98.46 | 79.07 | -39.8 | 58.66 | 39.27 | 74 | 54 | -15.34 | -14.73 |
| 12205 | V | 97.08 | 78.08 | -40.5 | 56.58 | 37.58 | 74 | 54 | -17.42 | -16.42 |
| 14646 | V | 97.32 | 78.25 | -41 | 56.32 | 37.25 | 74 | 54 | -17.68 | -16.75 |
| 17087 | V | 97.28 | 78.12 | -41.1 | 56.18 | 37.02 | 74 | 54 | -17.82 | -16.98 |
| 4882 | H | 94.07 | 74.62 | -31.6 | 62.47 | 43.02 | 74 | 54 | -11.53 | -10.98 |
| 7323 | H | 95.48 | 76.08 | -35.5 | 59.98 | 40.58 | 74 | 54 | -14.02 | -13.42 |
| 9764 | H | 96.26 | 77.12 | -38.3 | 57.96 | 38.82 | 74 | 54 | -16.04 | -15.18 |
| 12205 | H | 95.88 | 76.25 | -39 | 56.88 | 37.25 | 74 | 54 | -17.12 | -16.75 |
| 14646 | H | 98.32 | 79.02 | -42 | 56.32 | 37.02 | 74 | 54 | -17.68 | -16.98 |
| 17087 | H | 97.88 | 78.65 | -41.4 | 56.48 | 37.25 | 74 | 54 | -17.52 | -16.75 |

Operation Mode: Pi/4-DQPSK (CH79: 2480MHz) Test Date : 2022-03-23

| Freq. (MHz) | Ant. Pol. | Reading Level(dBuV/m) | | Correct Factor dB | Emission Level(dBuV/m) | | Limit 3m(dBuV/m) | | Over(dB) | |
|----------------|--------------|--------------------------|-------|-------------------------|---------------------------|-------|---------------------|----|----------|--------|
| | | PK | AV | | PK | AV | PK | AV | PK | AV |
| 4960 | V | 95.32 | 76.47 | -32.3 | 63.02 | 44.17 | 74 | 54 | -10.98 | -9.83 |
| 7440 | V | 98.78 | 79.42 | -37.2 | 61.58 | 42.22 | 74 | 54 | -12.42 | -11.78 |
| 9920 | V | 99.43 | 79.95 | -39.8 | 59.63 | 40.15 | 74 | 54 | -14.37 | -13.85 |
| 12400 | V | 98.02 | 79.08 | -40.5 | 57.52 | 38.58 | 74 | 54 | -16.48 | -15.42 |
| 14880 | V | 97.47 | 78.33 | -41 | 56.47 | 37.33 | 74 | 54 | -17.53 | -16.67 |
| 17360 | V | 96.78 | 77.68 | -41.1 | 55.68 | 36.58 | 74 | 54 | -18.32 | -17.42 |
| 4960 | H | 94.73 | 75.66 | -31.6 | 63.13 | 44.06 | 74 | 54 | -10.87 | -9.94 |
| 7440 | H | 96.75 | 78.08 | -35.5 | 61.25 | 42.58 | 74 | 54 | -12.75 | -11.42 |
| 9920 | H | 97.88 | 78.5 | -38.3 | 59.58 | 40.2 | 74 | 54 | -14.42 | -13.8 |
| 12400 | H | 96.48 | 77.58 | -39 | 57.48 | 38.58 | 74 | 54 | -16.52 | -15.42 |
| 14880 | H | 98.32 | 79.16 | -42 | 56.32 | 37.16 | 74 | 54 | -17.68 | -16.84 |
| 17360 | H | 97.83 | 78.52 | -41.5 | 56.33 | 37.02 | 74 | 54 | -17.67 | -16.98 |



Report No.: E01A22030472F00501

28 of 78

Operation Mode: 8DPSK (CH1: 2402MHz) Test Date : 2022-03-23

| Freq. (MHz) | Ant. Pol. H/V | Reading Level(dBuV/m) | | Correct Factor dB | Emission Level(dBuV/m) | | Limit 3m(dBuV/m) | | Over(dB) | |
|----------------|------------------|-----------------------|-------|----------------------|------------------------|-------|------------------|----|----------|-------|
| | | PK | AV | | PK | AV | PK | AV | PK | AV |
| 4804 | V | 94.6 | 75.52 | -32.3 | 62.3 | 43.22 | 74 | 54 | -11.7 | -10.8 |
| 7206 | V | 97.53 | 78.89 | -37.2 | 60.33 | 41.69 | 74 | 54 | -13.67 | -12.3 |
| 9608 | V | 99.27 | 80.05 | -39.8 | 59.47 | 40.25 | 74 | 54 | -14.53 | -13.8 |
| 12010 | V | 98.86 | 80.08 | -40.5 | 58.36 | 39.58 | 74 | 54 | -15.64 | -14.4 |
| 14412 | V | 98.28 | 79.11 | -41.7 | 56.58 | 37.41 | 74 | 54 | -17.42 | -16.6 |
| 16814 | V | 95.71 | 76.58 | -40 | 55.71 | 36.58 | 74 | 54 | -18.29 | -17.4 |
| 4804 | H | 93.75 | 74.67 | -31.6 | 62.15 | 43.07 | 74 | 54 | -11.85 | -10.9 |
| 7206 | H | 95.83 | 77 | -35.5 | 60.33 | 41.5 | 74 | 54 | -13.67 | -12.5 |
| 9608 | H | 97.66 | 78.82 | -38.3 | 59.36 | 40.52 | 74 | 54 | -14.64 | -13.5 |
| 12010 | H | 97.17 | 78.45 | -39 | 58.17 | 39.45 | 74 | 54 | -15.83 | -14.6 |
| 14412 | H | 98.47 | 79.58 | -42 | 56.47 | 37.58 | 74 | 54 | -17.53 | -16.4 |
| 16814 | H | 94.66 | 75.88 | -39.3 | 55.36 | 36.58 | 74 | 54 | -18.64 | -17.4 |

Operation Mode: 8DPSK (CH40: 2441MHz) Test Date : 2022-03-23

| Freq. (MHz) | Ant. Pol. H/V | Reading Level(dBuV/m) | | Correct Factor dB | Emission Level(dBuV/m) | | Limit 3m(dBuV/m) | | Over(dB) | |
|----------------|------------------|-----------------------|-------|----------------------|------------------------|-------|------------------|----|----------|--------|
| | | PK | AV | | PK | AV | PK | AV | PK | AV |
| 4882 | V | 95.32 | 76.55 | -32.3 | 63.02 | 44.25 | 74 | 54 | -10.98 | -9.75 |
| 7323 | V | 98.52 | 79.22 | -37.2 | 61.32 | 42.02 | 74 | 54 | -12.68 | -11.98 |
| 9764 | V | 99.13 | 80.05 | -39.8 | 59.33 | 40.25 | 74 | 54 | -14.67 | -13.75 |
| 12205 | V | 98.82 | 79.66 | -40.5 | 58.32 | 39.16 | 74 | 54 | -15.68 | -14.84 |
| 14646 | V | 98.25 | 79.02 | -41 | 57.25 | 38.02 | 74 | 54 | -16.75 | -15.98 |
| 17087 | V | 97.27 | 78.24 | -41.1 | 56.17 | 37.14 | 74 | 54 | -17.83 | -16.86 |
| 4882 | H | 94.71 | 75.56 | -31.6 | 63.11 | 43.96 | 74 | 54 | -10.89 | -10.04 |
| 7323 | H | 96.86 | 78.19 | -35.5 | 61.36 | 42.69 | 74 | 54 | -12.64 | -11.31 |
| 9764 | H | 97.71 | 78.69 | -38.3 | 59.41 | 40.39 | 74 | 54 | -14.59 | -13.61 |
| 12205 | H | 97.31 | 78.81 | -39 | 58.31 | 39.81 | 74 | 54 | -15.69 | -14.19 |
| 14646 | H | 98.32 | 79.14 | -42 | 56.32 | 37.14 | 74 | 54 | -17.68 | -16.86 |
| 17087 | H | 98.05 | 79.12 | -41.5 | 56.55 | 37.62 | 74 | 54 | -17.45 | -16.38 |

Operation Mode: 8DPSK (CH79: 2480MHz) Test Date : 2022-03-23



| Freq. | Ant. Pol. | Reading Level(dBuV/m) | | Correct Factor | Emission Level(dBuV/m) | | Limit 3m(dBuV/m) | | Over(dB) | |
|-------|-----------|-----------------------|-------|----------------|------------------------|-------|------------------|----|----------|--------|
| | | PK | AV | | PK | AV | PK | AV | PK | AV |
| (MHz) | H/V | PK | AV | dB | PK | AV | PK | AV | PK | AV |
| 4960 | V | 96.55 | 77.62 | -32.3 | 64.25 | 45.32 | 74 | 54 | -9.75 | -8.68 |
| 7440 | V | 99.53 | 80.22 | -37.2 | 62.33 | 43.02 | 74 | 54 | -11.67 | -10.98 |
| 9920 | V | 100.27 | 81.54 | -39.8 | 60.47 | 41.74 | 74 | 54 | -13.53 | -12.26 |
| 12400 | V | 99.86 | 80.65 | -40.5 | 59.36 | 40.15 | 74 | 54 | -14.64 | -13.85 |
| 14880 | V | 99.22 | 80.13 | -41 | 58.22 | 39.13 | 74 | 54 | -15.78 | -14.87 |
| 17360 | V | 97.73 | 78.68 | -41.1 | 56.63 | 37.58 | 74 | 54 | -17.37 | -16.42 |
| 4960 | H | 95.83 | 76.39 | -31.6 | 64.23 | 44.79 | 74 | 54 | -9.77 | -9.21 |
| 7440 | H | 97.53 | 77.72 | -35.5 | 62.03 | 42.22 | 74 | 54 | -11.97 | -11.78 |
| 9920 | H | 97.98 | 78.55 | -38.3 | 59.68 | 40.25 | 74 | 54 | -14.32 | -13.75 |
| 12400 | H | 97.74 | 78.78 | -39 | 58.74 | 39.78 | 74 | 54 | -15.26 | -14.22 |
| 14880 | H | 99.52 | 80.16 | -42 | 57.52 | 38.16 | 74 | 54 | -16.48 | -15.84 |
| 17360 | H | 97.82 | 77.97 | -41.5 | 56.32 | 36.47 | 74 | 54 | -17.68 | -17.53 |

Other harmonics emissions are lower than 20dB below the allowable limit.

- Note:**
- (1) All Readings are Peak Value and AV.
 - (2) Emission Level= Reading Level+ Probe Factor +Cable Loss.
 - (3) The average measurement was not performed when the peak measured data under the limit of average detection.
 - (4) Measuring frequencies from 1GHz to 25GHz.

7.5 Radiated Measurement Photos:

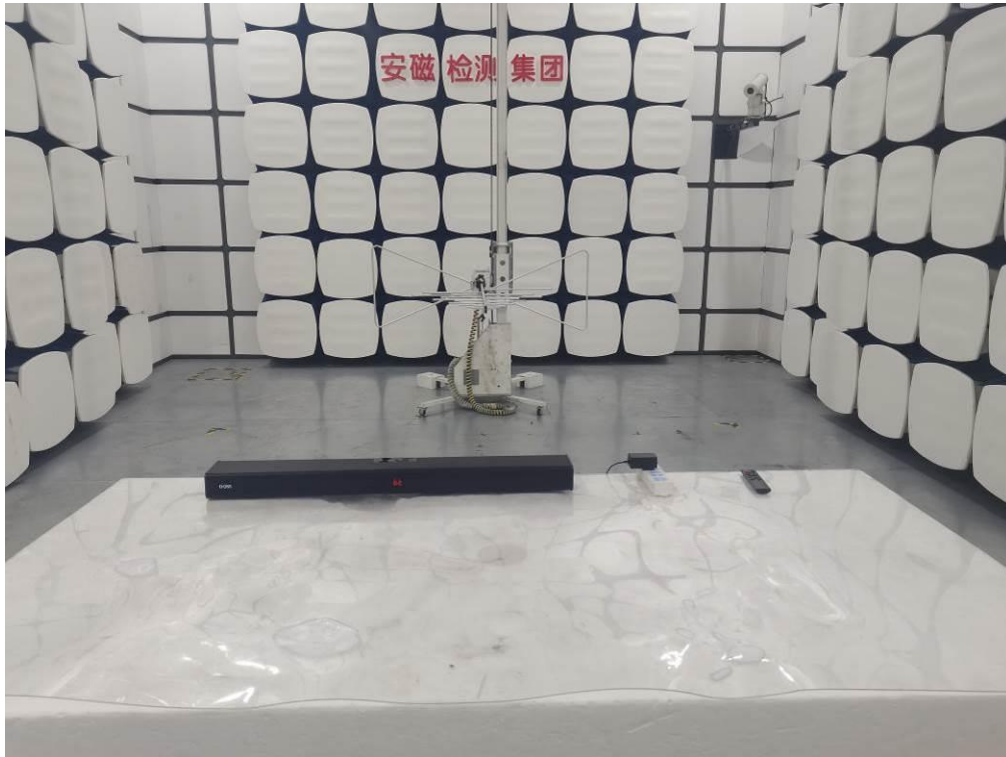

8. Channel Separation test

8.1 Measurement Procedure

The EUT was operating in hopping mode or could be controlled its channel. Printed out the test result from the spectrum by hard copy function.

8.2 Test SET-UP (Block Diagram of Configuration)

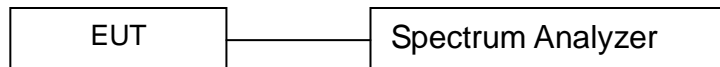

8.3 Measurement Equipment Used:

| EQUIPMENT TYPE | MFR | MODEL NUMBER | SERIAL NUMBER | CALIBRATED UNTIL |
|-------------------|--------------------|--------------|---------------|------------------|
| Spectrum Analyzer | Rohde & Schwarz | FSV40 | US40240623 | 2022-05-20 |
| Coaxial Cable | Gigalink Microwave | ZT40 | 19022092 | 2022-05-20 |
| Antenna Connector | ARTHUR-YANG | 2244-N1TG1 | N/A | 2022-05-20 |

Remark: The temporary antenna connector is soldered on the PCB board in order to perform conducted tests and this temporary antenna connector is listed in the equipment list.

8.4 Measurement Results:

Refer to attached data chart.



Spectrum Detector: PK Test Date : 2022-03-23
Test By: Best Temperature : 24°C
Test Result: PASS Humidity : 53 %
Modulation: GFSK

| Channel number | Channel frequency (MHz) | Separation Read Value (kHz) | Separation Limit 20dB Down BW(kHz) |
|----------------|-------------------------|-----------------------------|------------------------------------|
| 1 | 2402 | 1000 | >940 |
| 40 | 2441 | 1000 | >944 |
| 79 | 2480 | 1000 | >939 |

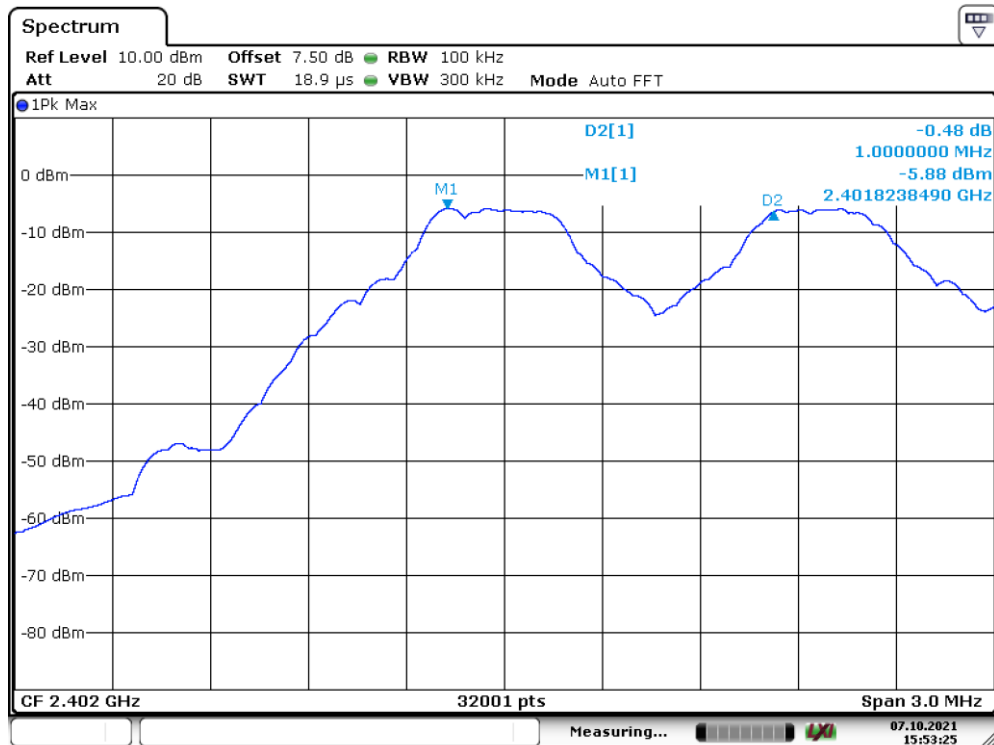

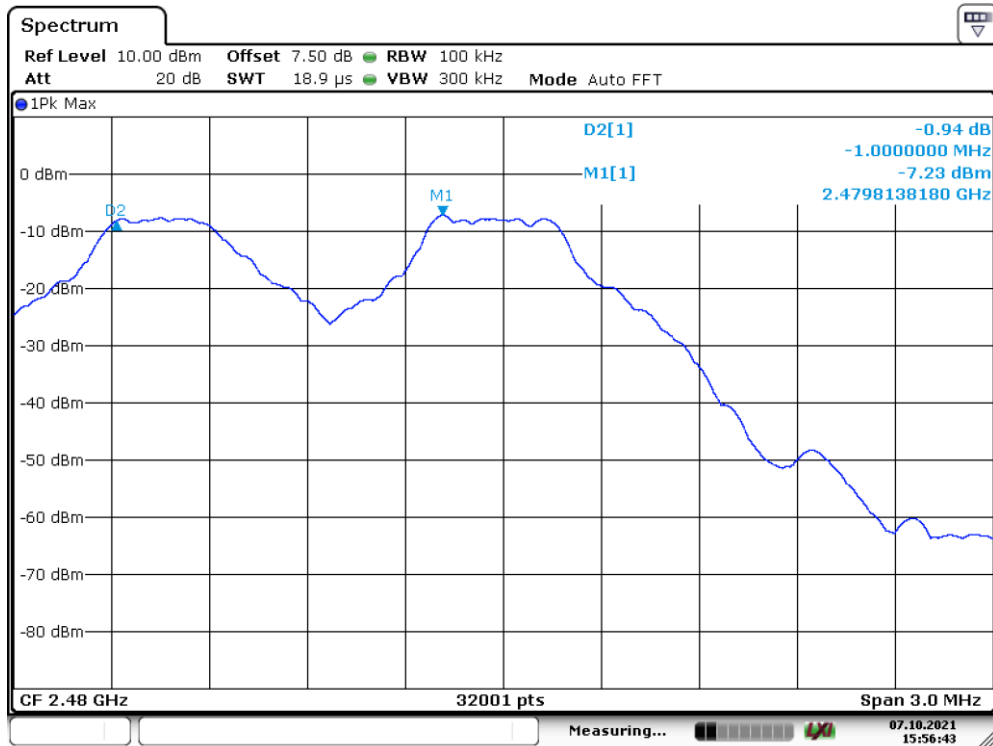
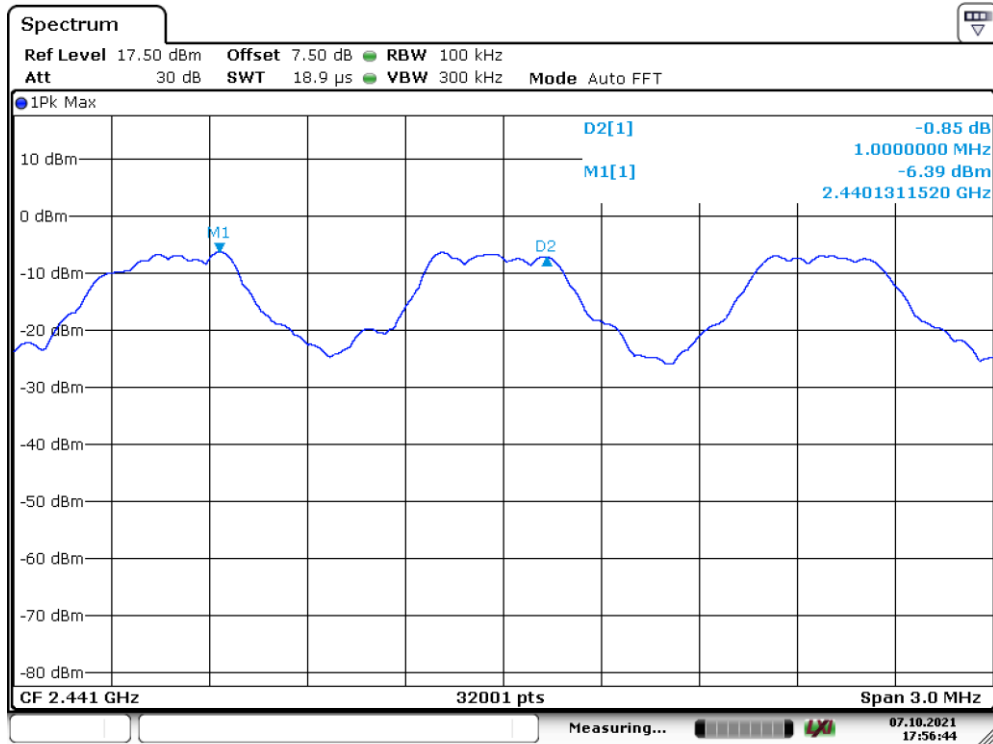



Report No.: E01A22030472F00501
Spectrum Detector: PK
Test By: Best
Test Result: PASS
Modulation: $\Pi/4$ -DQPSK

34 of 78
Test Date : 2022-03-23
Temperature : 24°C
Humidity : 53 %

| Channel number | Channel frequency (MHz) | Separation Read Value (kHz) | Separation Limit 2/3 20dB Down BW(kHz) |
|----------------|-------------------------|-----------------------------|--|
| 1 | 2402 | 1000 | >876 |
| 40 | 2441 | 1000 | >885 |
| 79 | 2480 | 1000 | >903 |

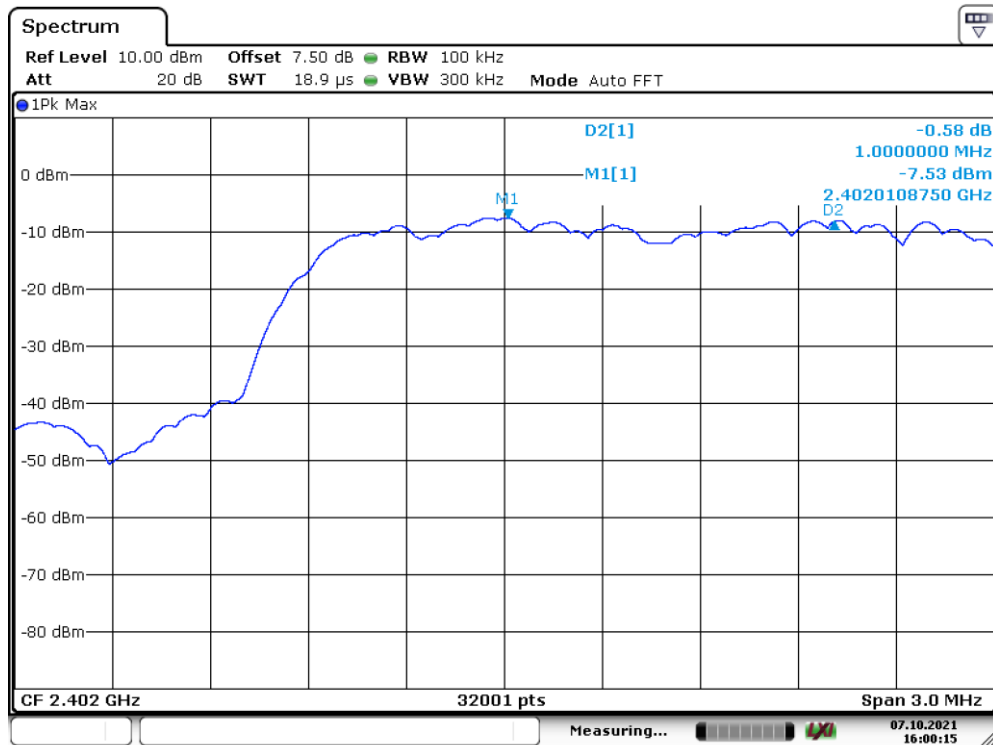

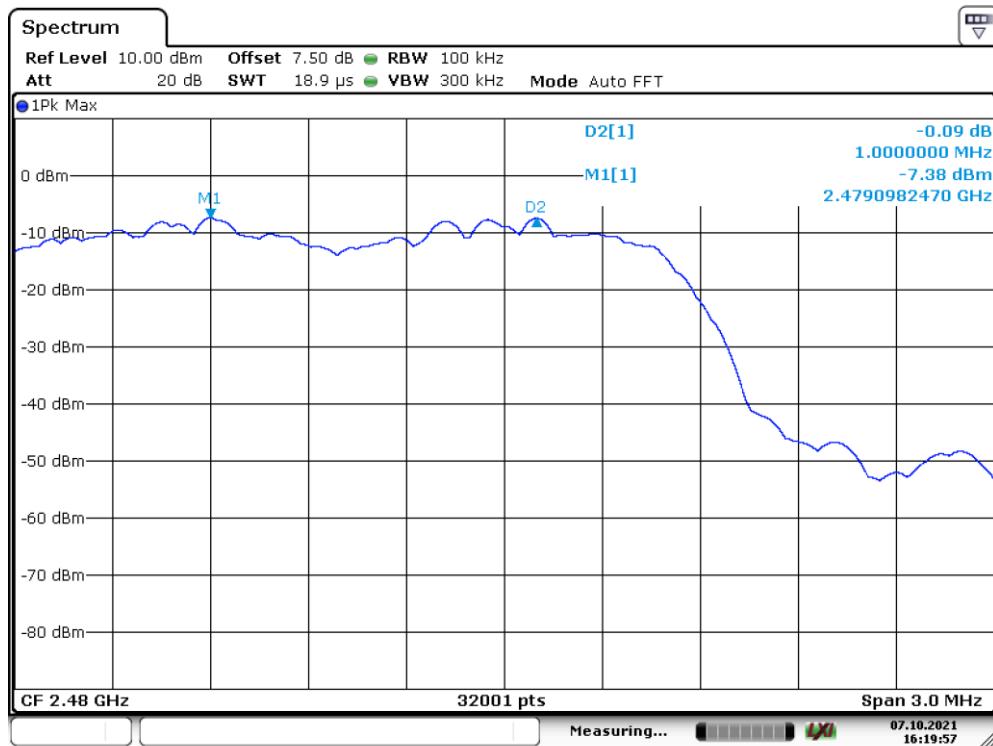
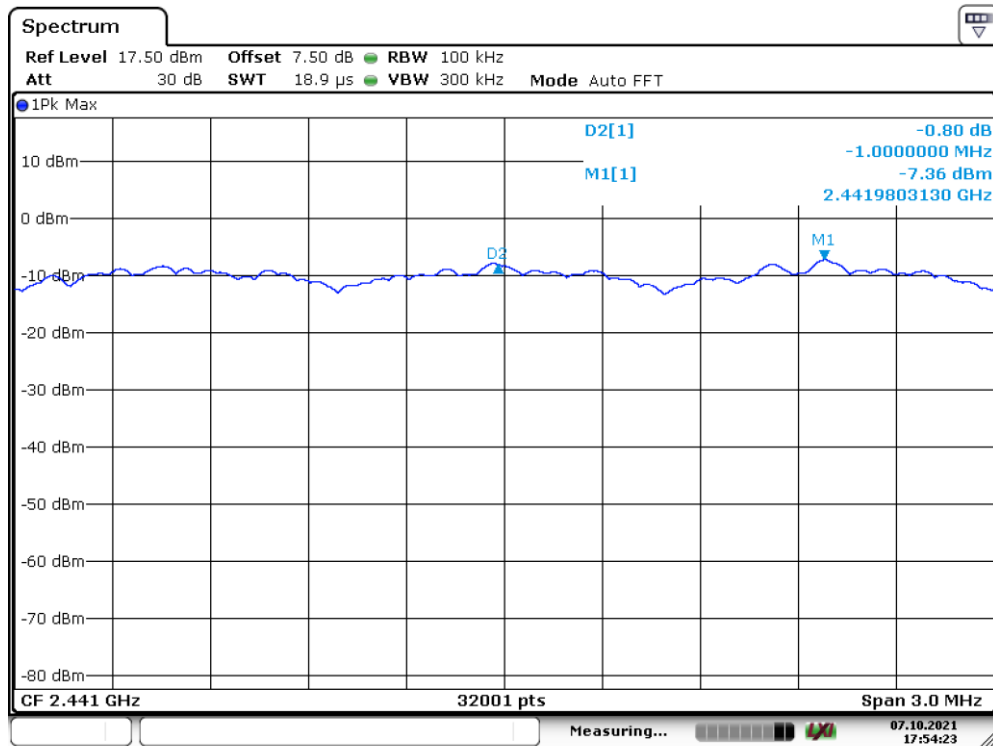

Report No.: E01A22030472F00501

36 of 78

Spectrum Detector: PK

Test Date : 2022-03-23

Test By: Best

Temperature : 24°C

Test Result: PASS

Humidity : 53 %

Modulation: 8DPSK

| Channel number | Channel frequency (MHz) | Separation Read Value (kHz) | Separation Limit 2/3 20dB Down BW(kHz) |
|----------------|-------------------------|-----------------------------|--|
| 1 | 2402 | 1000 | >855 |
| 40 | 2441 | 1000 | >853 |
| 79 | 2480 | 1000 | >846 |

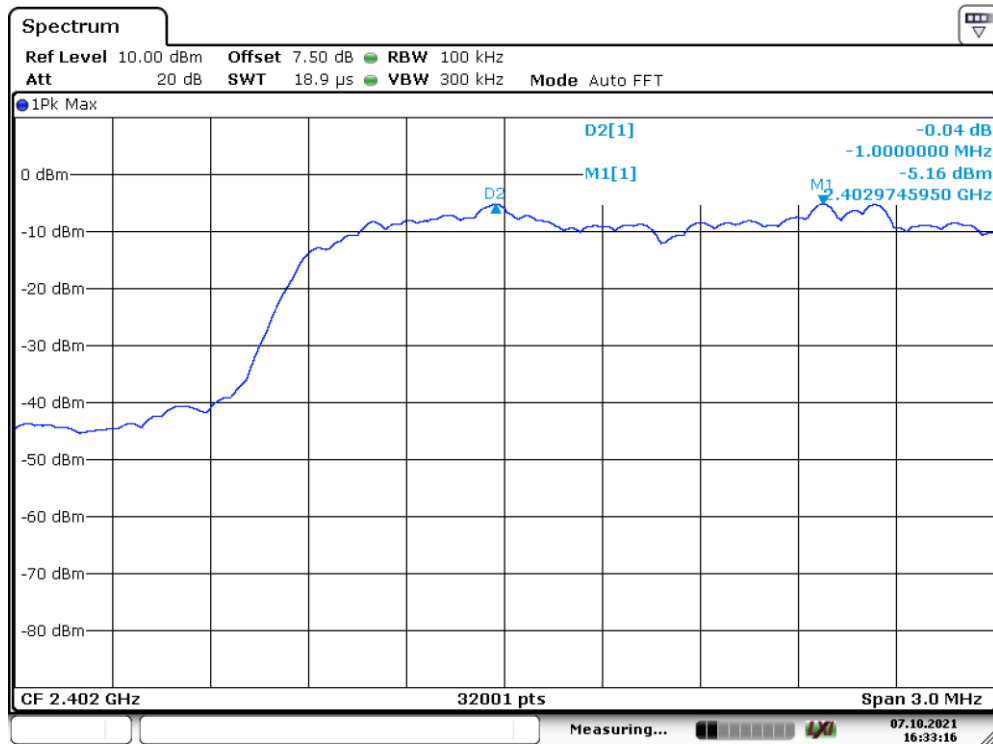

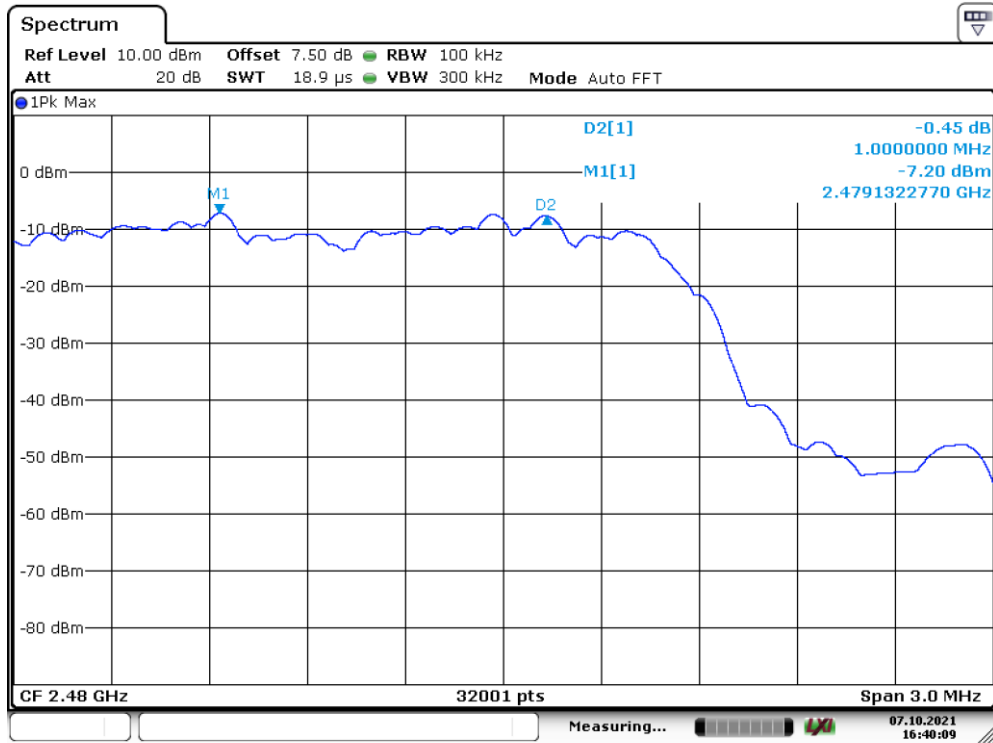
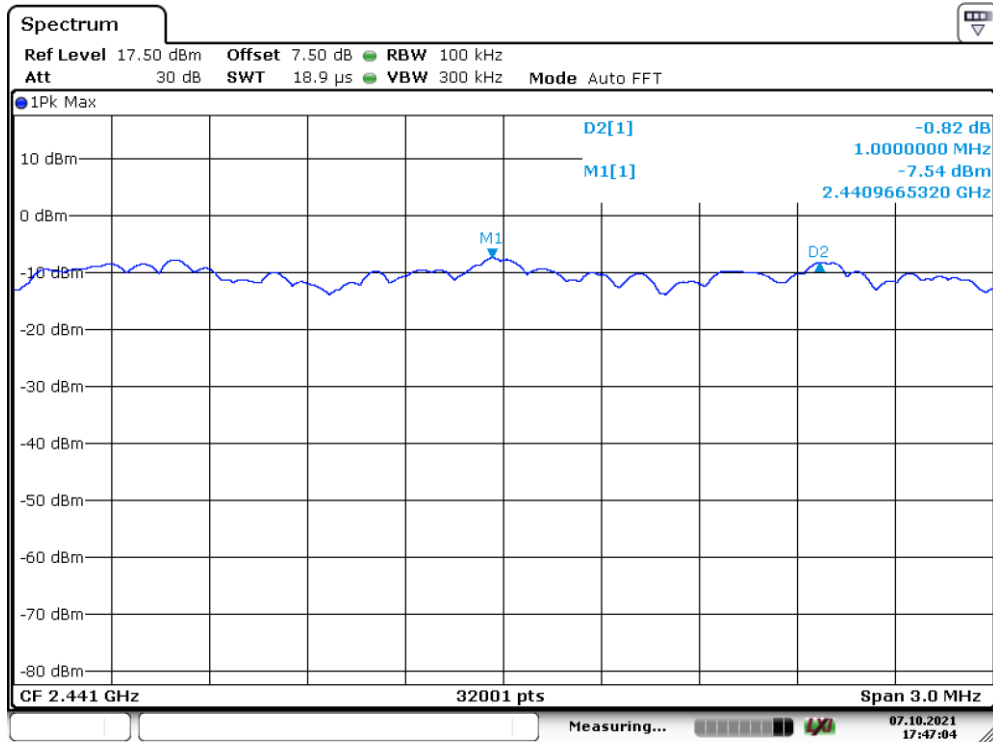

9. 20dB Bandwidth test

9.1 Measurement Procedure

The EUT was operating in hopping mode or could be controlled its channel. Printed out the test result from the spectrum by hard copy function.

9.2 Test SET-UP (Block Diagram of Configuration)

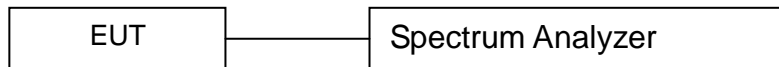

9.3 Measurement Equipment Used:

| EQUIPMENT TYPE | MFR | MODEL NUMBER | SERIAL NUMBER | CALIBRATED UNTIL |
|-------------------|--------------------|--------------|---------------|------------------|
| Spectrum Analyzer | Rohde & Schwarz | FSV40 | US40240623 | 2021-11-19 |
| Coaxial Cable | Gigalink Microwave | ZT40 | 19022092 | 2021-11-19 |
| Antenna Connector | ARTHUR-YANG | 2244-N1TG1 | N/A | 2021-11-19 |

Remark: The temporary antenna connector is soldered on the PCB board in order to perform conducted tests and this temporary antenna connector is listed in the equipment list.

9.4 Measurement Results:

Refer to attached data chart.

| | | | |
|--------------------|------|---------------|------------|
| Spectrum Detector: | PK | Test Date : | 2022-03-25 |
| Test By: | Best | Temperature : | 24°C |
| Test Result: | PASS | Humidity : | 53 % |
| Modulation: | GFSK | | |

| Channel number | Channel frequency (MHz) | 20dB Down BW(kHz) |
|----------------|-------------------------|-------------------|
| 1 | 2402 | 975 |
| 40 | 2441 | 1054 |
| 79 | 2480 | 994 |

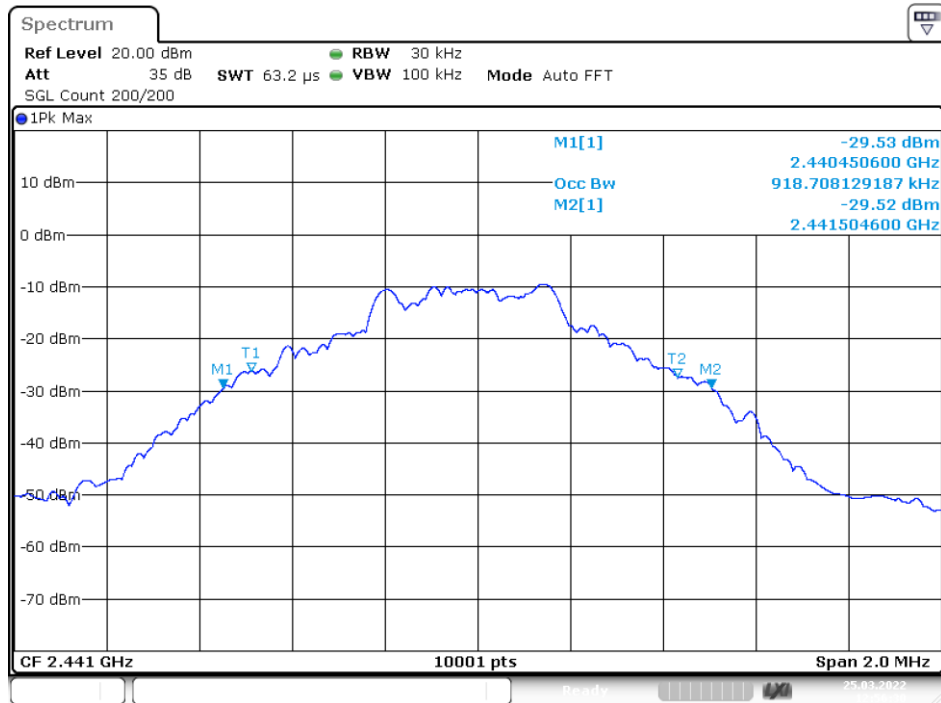
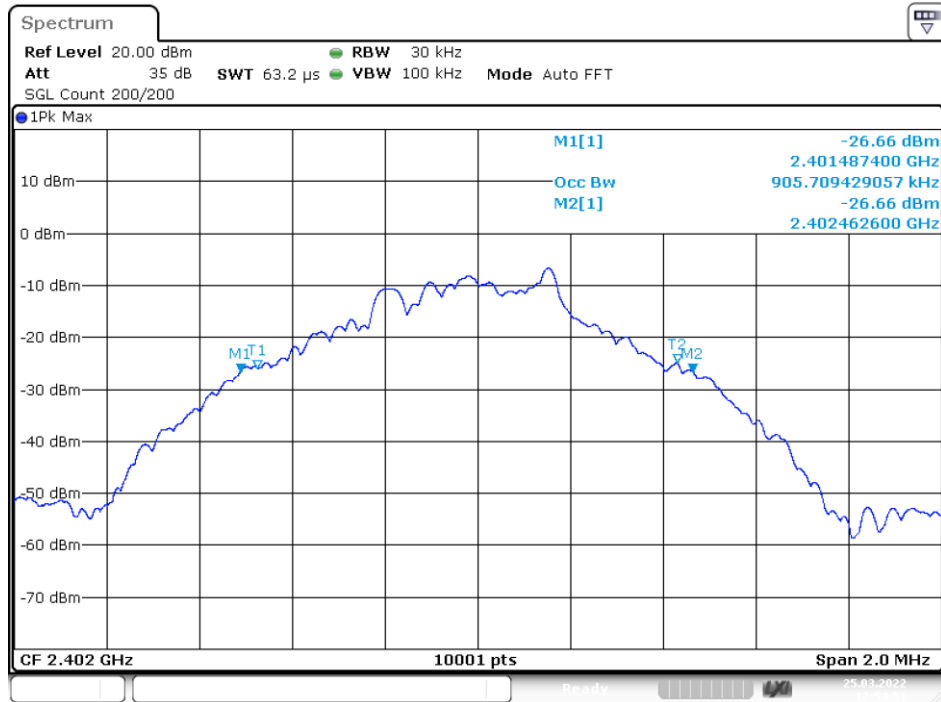

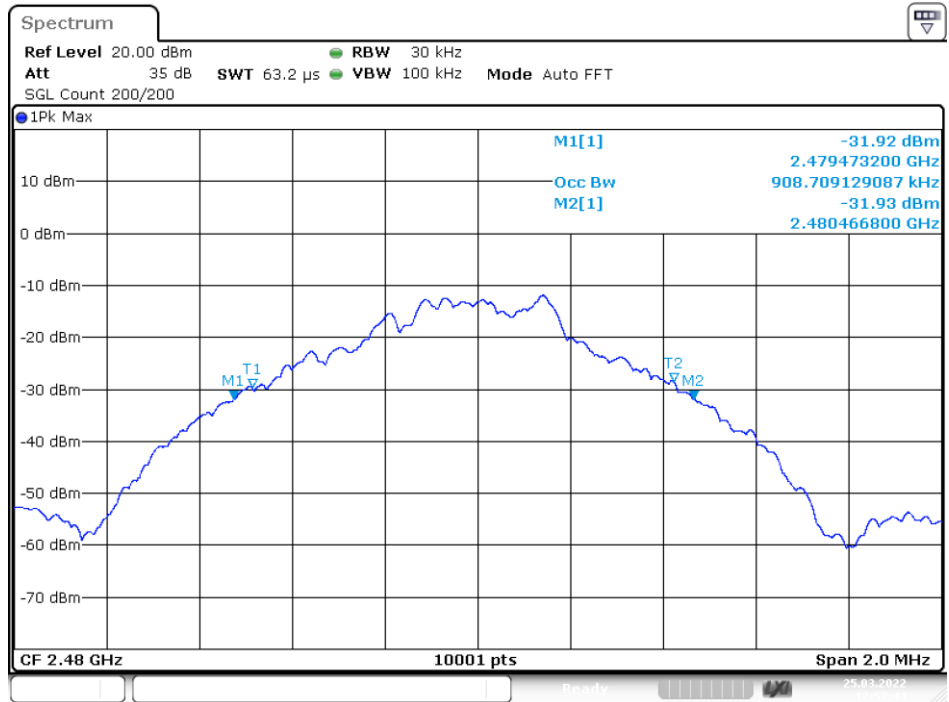

Date: 25.MAR.2022 12:57:44

| | | | |
|--------------------|-----------|---------------|------------|
| Spectrum Detector: | PK | Test Date : | 2022-03-25 |
| Test By: | Best | Temperature : | 24°C |
| Test Result: | PASS | Humidity : | 53 % |
| Modulation: | Π/4-DQPSK | | |

| Channel number | Channel frequency (MHz) | 20dB Down BW(kHz) |
|----------------|-------------------------|-------------------|
| 1 | 2402 | 1295 |
| 40 | 2441 | 1313 |
| 79 | 2480 | 1305 |

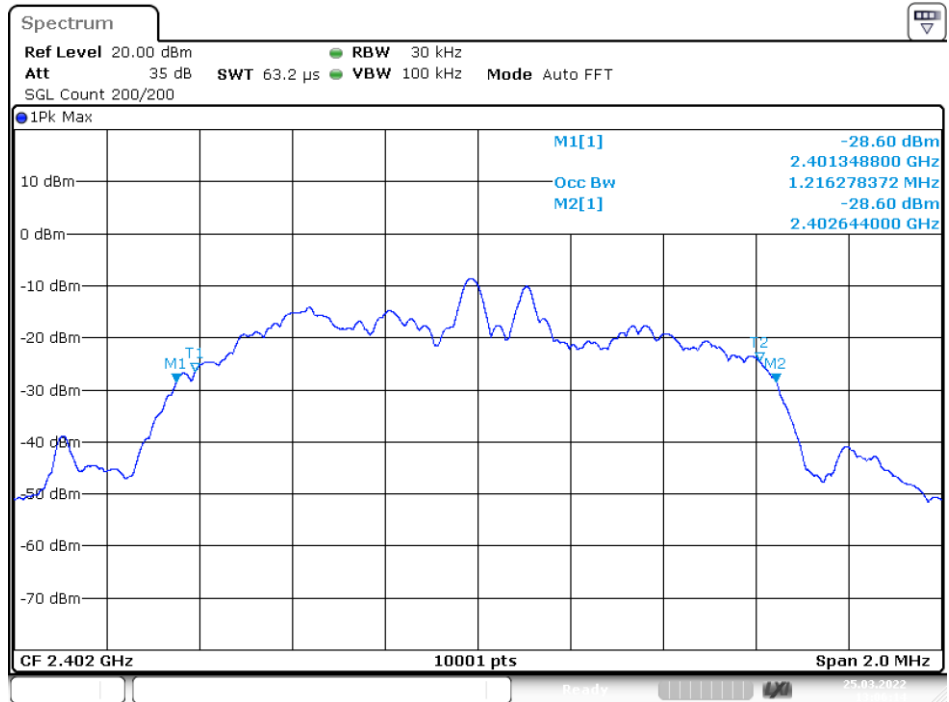

Date: 25.MAR.2022 13:06:13

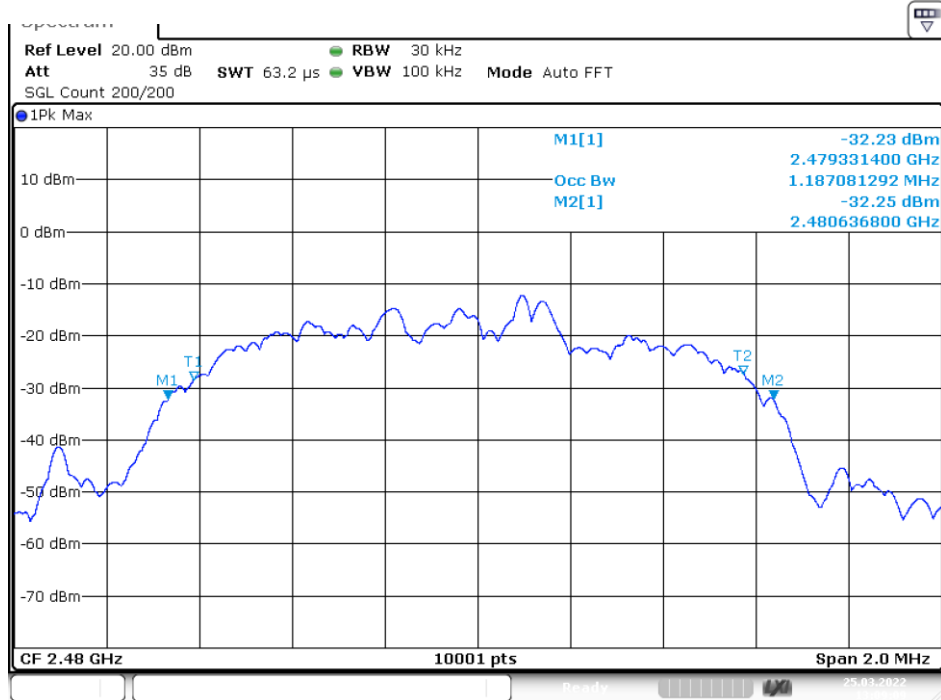
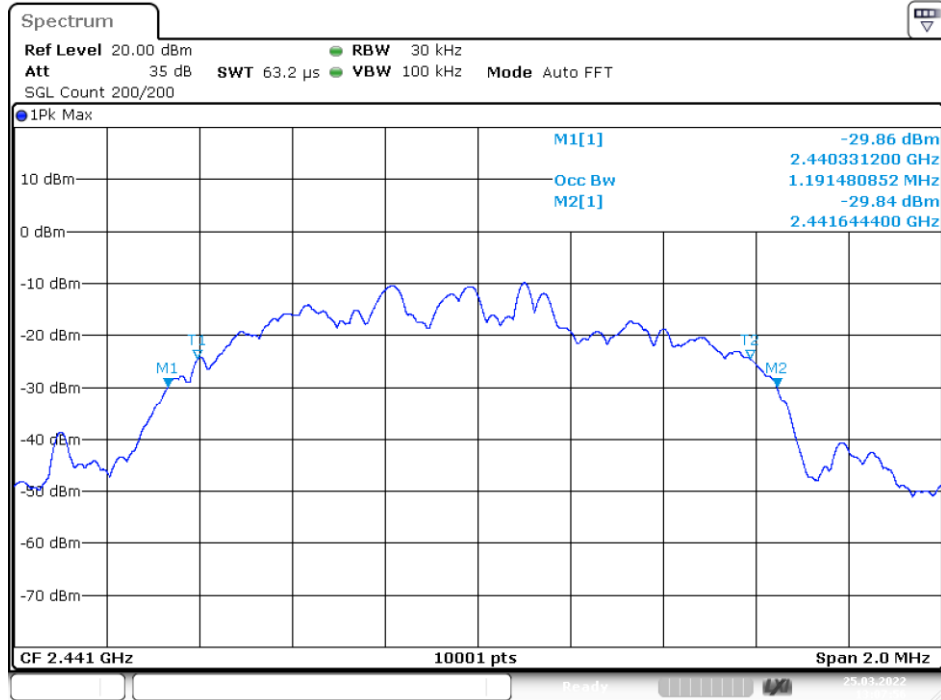

| | | | |
|--------------------|-------|---------------|------------|
| Spectrum Detector: | PK | Test Date : | 2022-03-25 |
| Test By: | Best | Temperature : | 24°C |
| Test Result: | PASS | Humidity : | 53 % |
| Modulation: | 8DPSK | | |

| Channel number | Channel frequency (MHz) | 20dB Down BW(kHz) |
|----------------|-------------------------|-------------------|
| 1 | 2402 | 1289 |
| 40 | 2441 | 1294 |
| 79 | 2480 | 1293 |

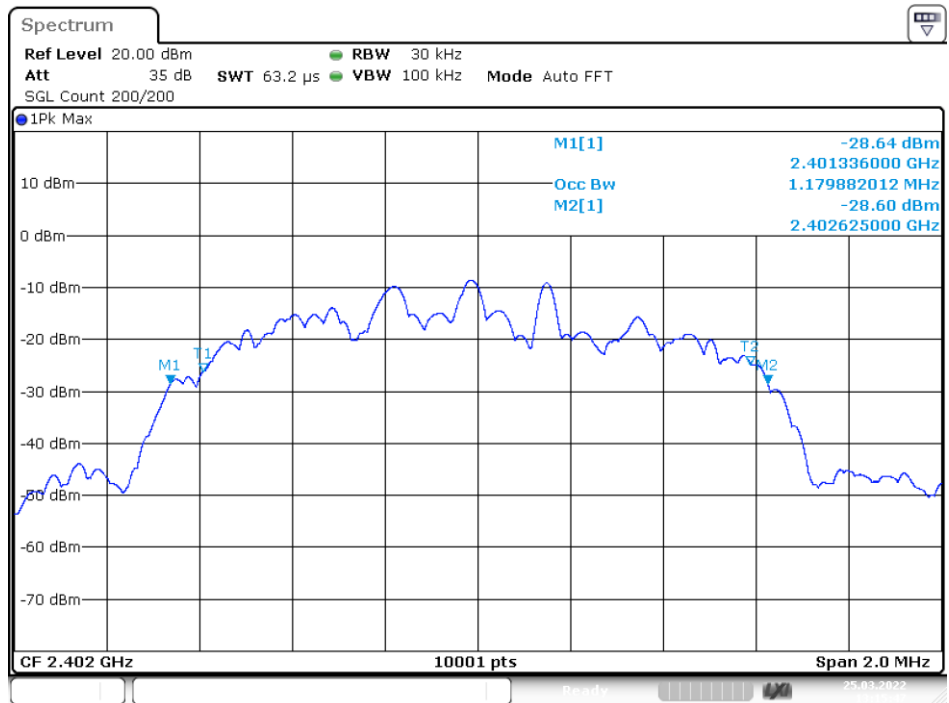

Date: 25.MAR.2022 13:15:47

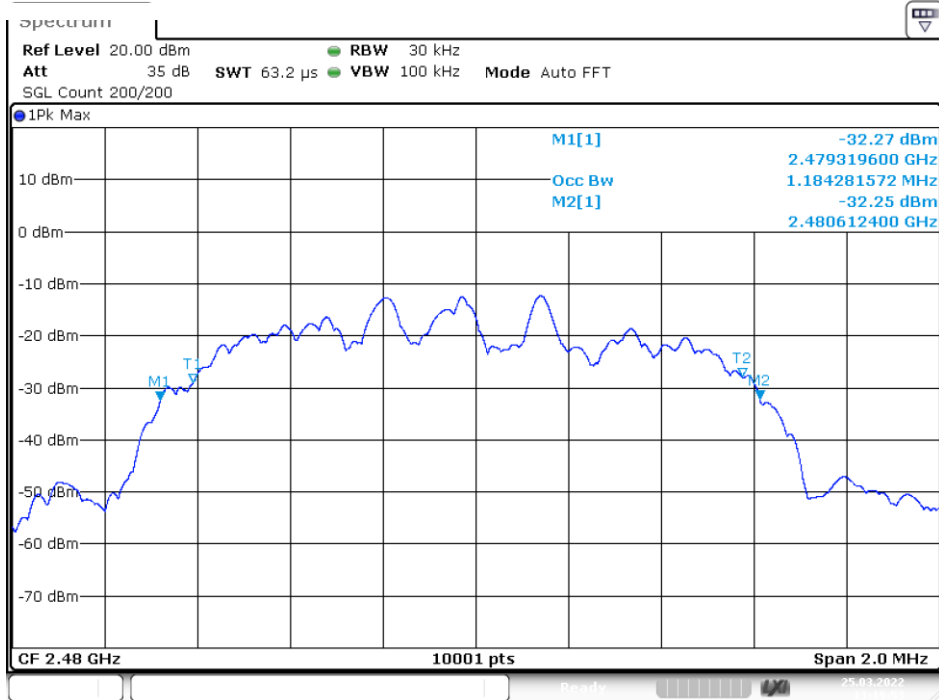
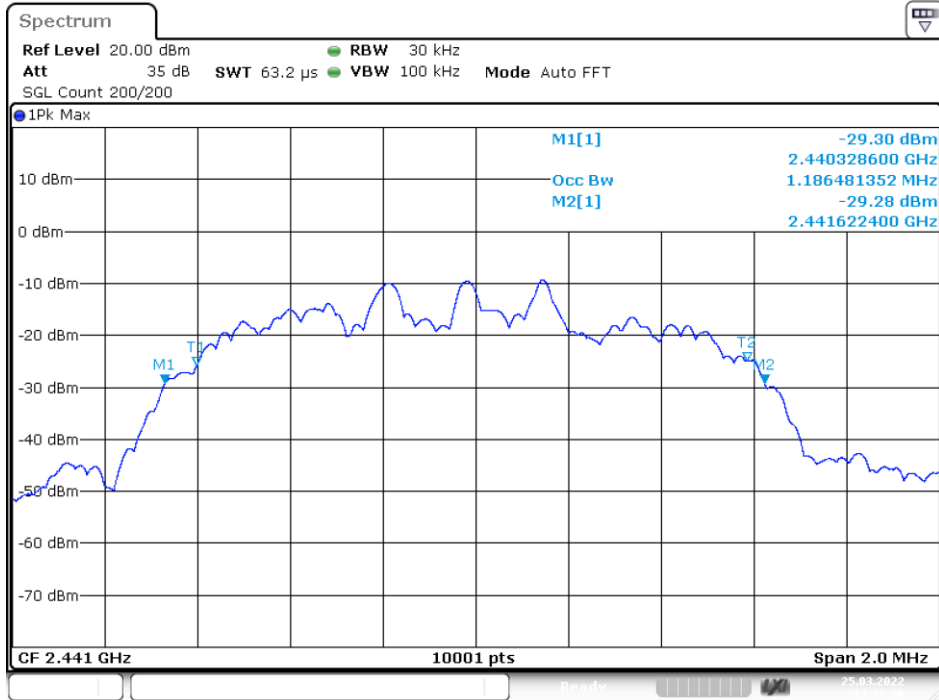

10. Quantity of Hopping Channel Test

10.1 Measurement Procedure

The EUT was operating in hopping mode or could be controlled its channel. Printed out the test result from the spectrum by hard copy function.

10.2 Test SET-UP (Block Diagram of Configuration)

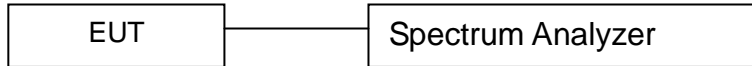

10.3 Measurement Equipment Used:

| EQUIPMENT TYPE | MFR | MODEL NUMBER | SERIAL NUMBER | CALIBRATED UNTIL |
|-------------------|--------------------|--------------|---------------|------------------|
| Spectrum Analyzer | Rohde & Schwarz | FSV40 | US40240623 | 2022-11-19 |
| Coaxial Cable | Gigalink Microwave | ZT40 | 19022092 | 2022-11-19 |
| Antenna Connector | ARTHUR-YANG | 2244-N1TG1 | N/A | 2022-11-19 |

Remark: The temporary antenna connector is soldered on the PCB board in order to perform conducted tests and this temporary antenna connector is listed in the equipment list.

10.4 Measurement Results:

Refer to attached data chart.

| | | | |
|-----------------|------|---------------|------------|
| Worst Test Mode | GFSK | Test Date : | 2022-03-25 |
| Test By: | Best | Temperature : | 24 °C |
| Test Result: | PASS | Humidity : | 53 % |

| Hopping Channel Frequency Range | Quantity of Hopping Channel | Quantity of Hopping Channel |
|---------------------------------|-----------------------------|-----------------------------|
| 2402-2480 | 79 | > 15 |

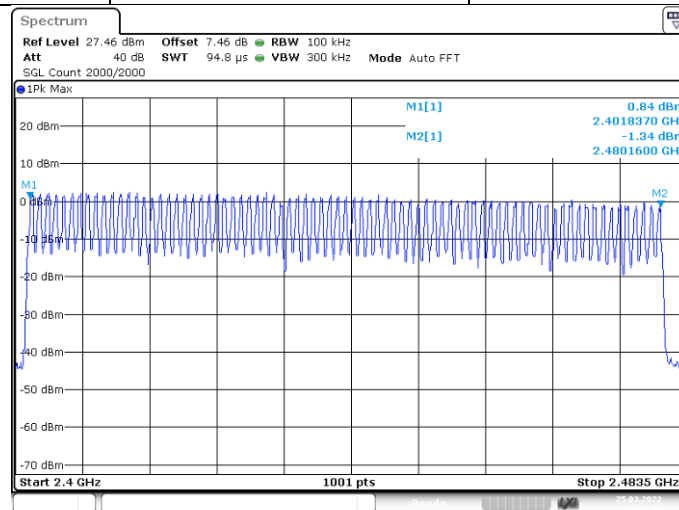

11. Time of Occupancy (Dwell Time) test

11.1 Test Description

The Equipment Under Test (EUT) was set up to perform the dwell time measurements. The EUT was connected to the spectrum analyzer via a short coax cable. The dwell time is calculated by:

$$\text{Dwell time} = \text{time slot length} * \text{hop rate} / \text{number of hopping channels} * 31.6\text{s}$$

with:

- hop rate = $1600 * 1/\text{s}$ for DH1 packets = 1600 s^{-1}
- hop rate = $1600/3 * 1/\text{s}$ for DH3 packets = 533.33 s^{-1}
- number of hopping channels = 79
- $31.6 \text{ s} = 0.4 \text{ seconds multiplied by the number of hopping channels} = 0.4 \text{ s} * 79$

The highest value of the dwell time is reported.

11.2 Test SET-UP (Block Diagram of Configuration)

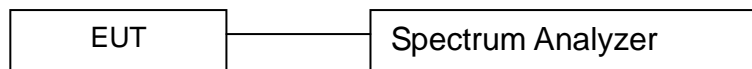

11.3 Measurement Equipment Used:

| EQUIPMENT TYPE | MFR | MODEL NUMBER | SERIAL NUMBER | CALIBRATED UNTIL |
|-------------------|--------------------|--------------|---------------|------------------|
| Spectrum Analyzer | Rohde & Schwarz | FSV40 | US40240623 | 2022-11-19 |
| Coaxial Cable | Gigalink Microwave | ZT40 | 19022092 | 2022-11-19 |
| Antenna Connector | ARTHUR-YANG | 2244-N1TG1 | N/A | 2022-11-19 |

Remark: The temporary antenna connector is soldered on the PCB board in order to perform conducted tests and this temporary antenna connector is listed in the equipment list.

11.4 Test Requirements / Limits

FCC Part 15, Subpart C, §15.247 (a) (1) (iii)

Frequency hopping systems in the 2400-2483.5 MHz band shall use at least 15 channels. The average time of occupancy on any channel shall not be greater than 0.4 seconds within a period of 0.4 seconds multiplied by the number of hopping channels employed. Since the Bluetooth technology uses 79 channels this period is calculated to be 31.6seconds. Refer to attached data chart.

| | | | |
|--------------|------|---------------|------------|
| Modulation: | GFSK | Test Date : | 2022-03-25 |
| Test By: | Best | Temperature : | 24 °C |
| Test Result: | PASS | Humidity : | 53 % |

11.5 Test result

| Mode | Number of transmission in a 31.6(79 Hopping*0.4) | Length of transmissions time(msec) | Result (msec) | Limit (msec) |
|------|---|------------------------------------|---------------|--------------|
| DH1 | $1600/(2*79) \times 31.6 = 320$ | 2.890 | 273.934 | 400 |
| DH3 | $1600/(4*79) \times 31.6 = 160$ | 2.889 | 273.896 | 400 |
| DH5 | $1600/(6*79) \times 31.6 = 106.67$ | 2.891 | 274.048 | 400 |

Remark: The results of worst cased was recorded.

DH1:

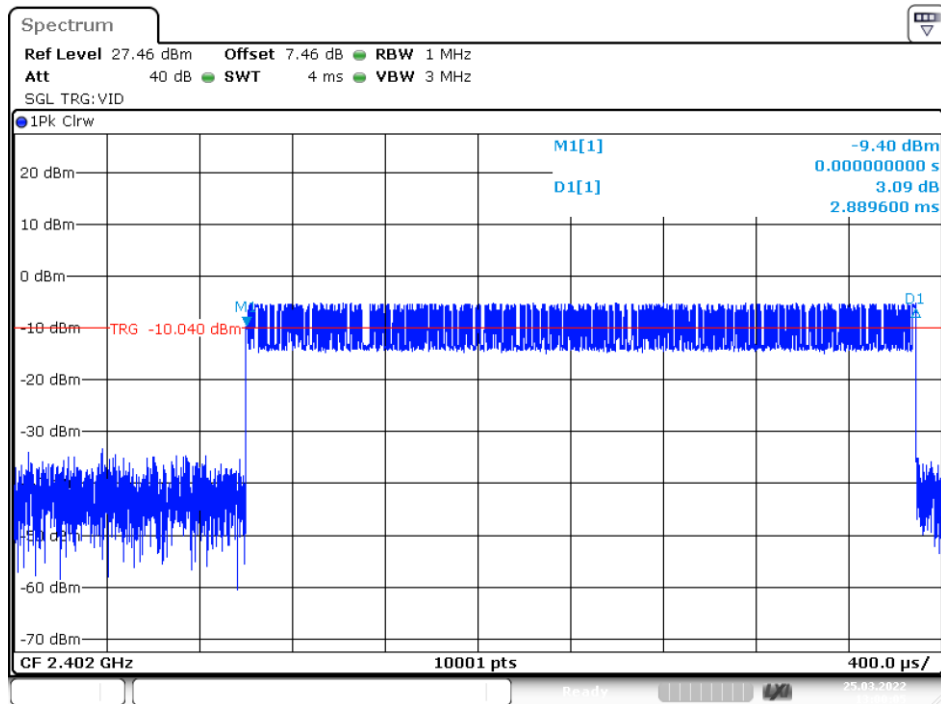

DH3:

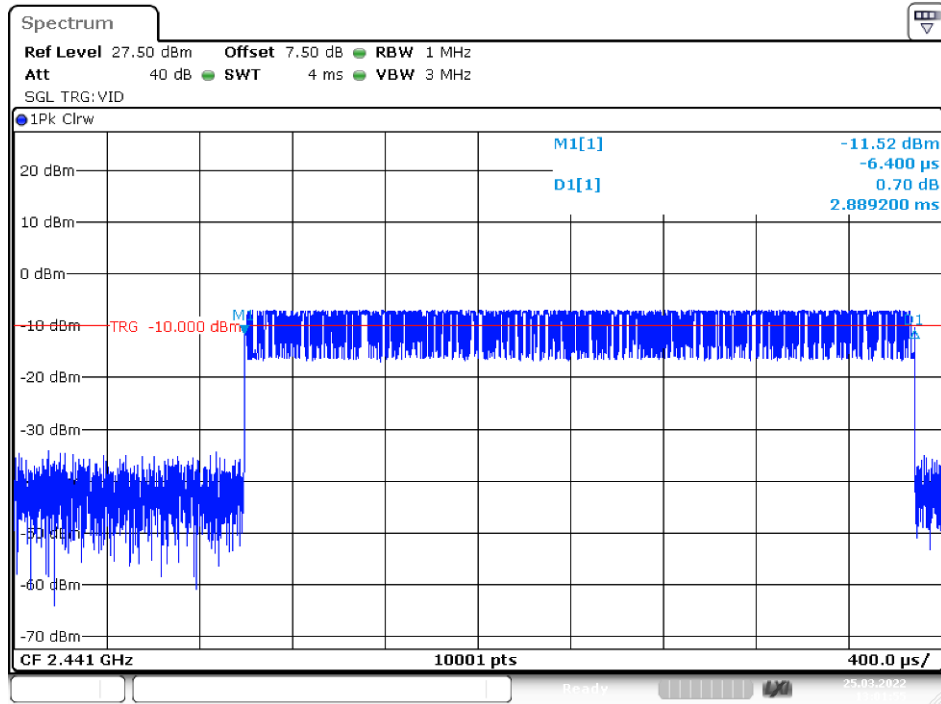

Date: 25.MAR.2022 13:01:55

DH5:

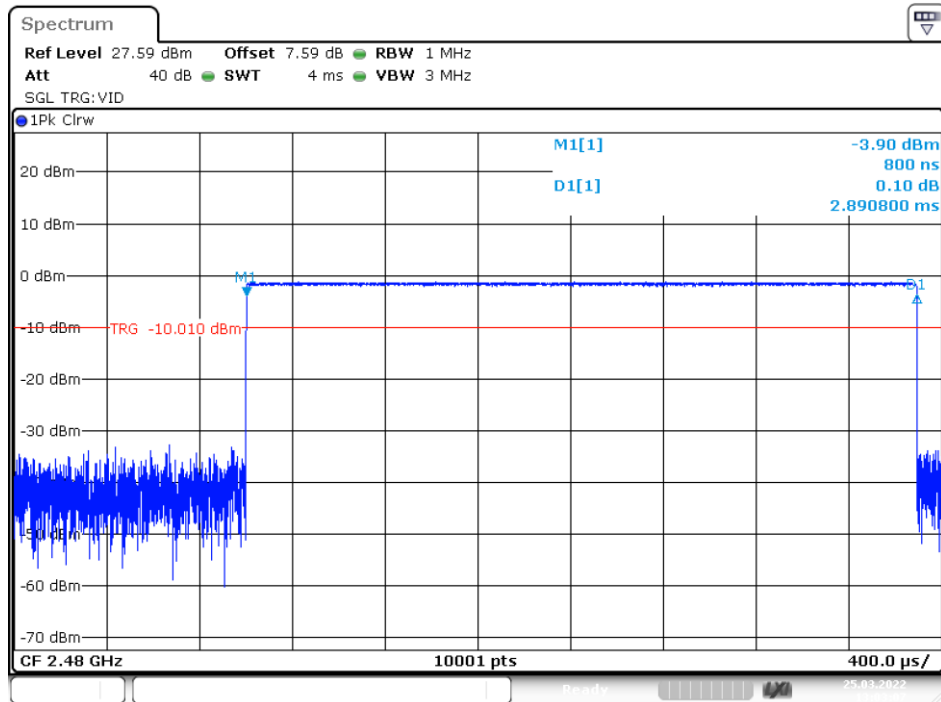

Date: 25.MAR.2022 13:03:07

12. MAXIMUM PEAK OUTPUT POWER TEST

12.1 Measurement Procedure

- a. Check the calibration of the measuring instrument(SA) using either an internal calibrator or a known signal from an external generator.
- b. Turn on the EUT and connect it to measurement instrument. Then set it to any one convenient frequency within its operating range. Set a reference level on the measuring instrument equal to the highest peak value.
- c. The center frequency of the spectrum analyzer is set to the fundamental frequency and using proper RBW and VBW setting.
- d. Measure the captured power within the band and recording the plot.
- e. Repeat above procedures until all frequencies required were complete.

12.2 Test SET-UP (Block Diagram of Configuration)

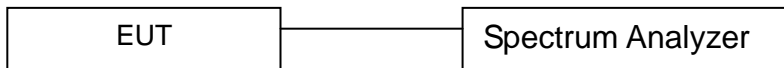

12.3 Measurement Equipment Used:

| EQUIPMENT TYPE | MFR | MODEL NUMBER | SERIAL NUMBER | CALIBRATED UNTIL |
|-------------------|--------------------|--------------|---------------|------------------|
| Spectrum Analyzer | Rohde & Schwarz | FSV40 | US40240623 | 2021-11-19 |
| Coaxial Cable | Gigalink Microwave | ZT40 | 19022092 | 2021-11-19 |
| Antenna Connector | ARTHUR-YANG | 2244-N1TG1 | N/A | 2021-11-19 |

Remark: The temporary antenna connector is soldered on the PCB board in order to perform conducted tests and this temporary antenna connector is listed in the equipment list.

12.4 Measurement Results:

Refer to attached data chart.

| | | | |
|--------------------|------|---------------|------------|
| Spectrum Detector: | PK | Test Date : | 2022-03-25 |
| Test By: | Best | Temperature : | 24 °C |
| Test Result: | PASS | Humidity : | 53 % |
| Modulation: | GFSK | | |

| Channel number | Channel Frequency (MHz) | Peak Power output(dBm) | Peak Power output(mW) | Peak Power Limit(mW) | Pass/Fail |
|----------------|-------------------------|------------------------|-----------------------|----------------------|-----------|
| 01 | 2402 | 2.27 | 1.687 | 1000 | PASS |
| 40 | 2441 | 1.47 | 1.403 | 1000 | PASS |
| 79 | 2480 | -1.18 | 0.762 | 1000 | PASS |

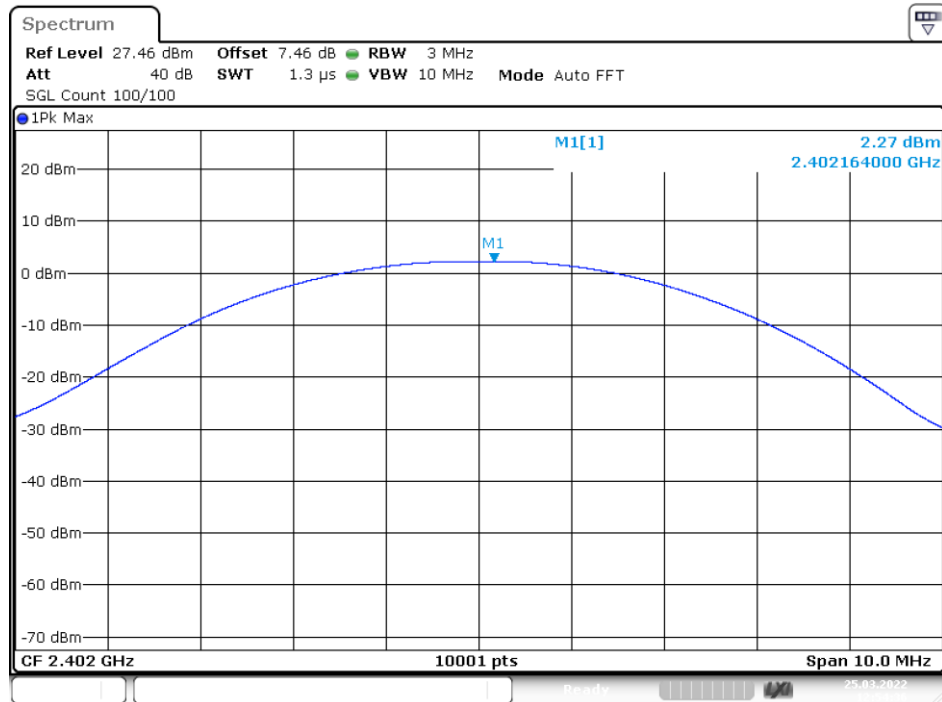

Date: 25.MAR.2022 12:54:36

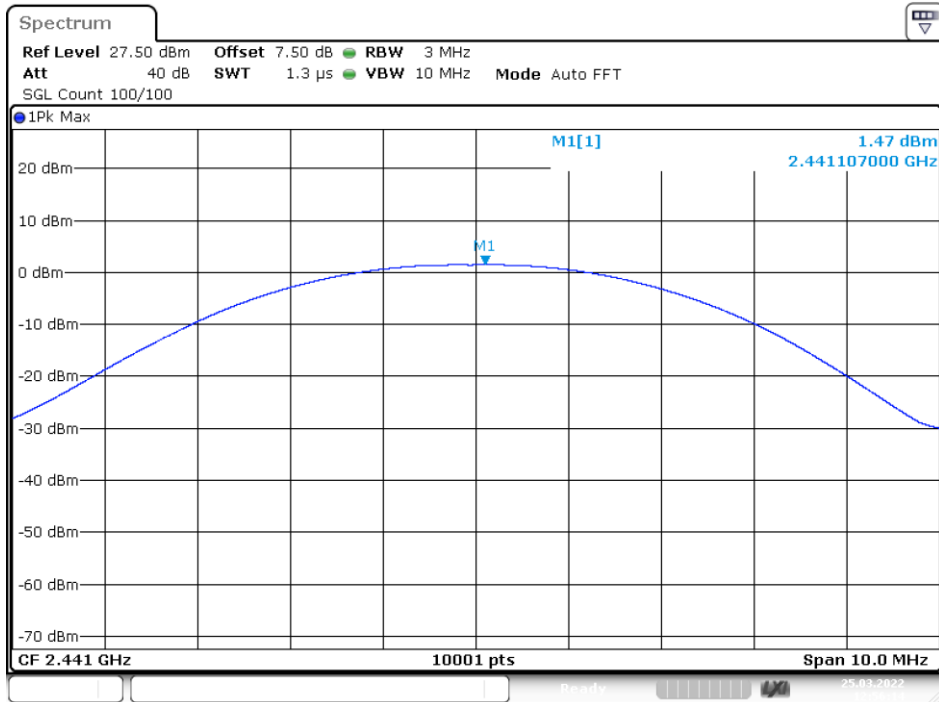

Date: 25.MAR.2022 12:56:14

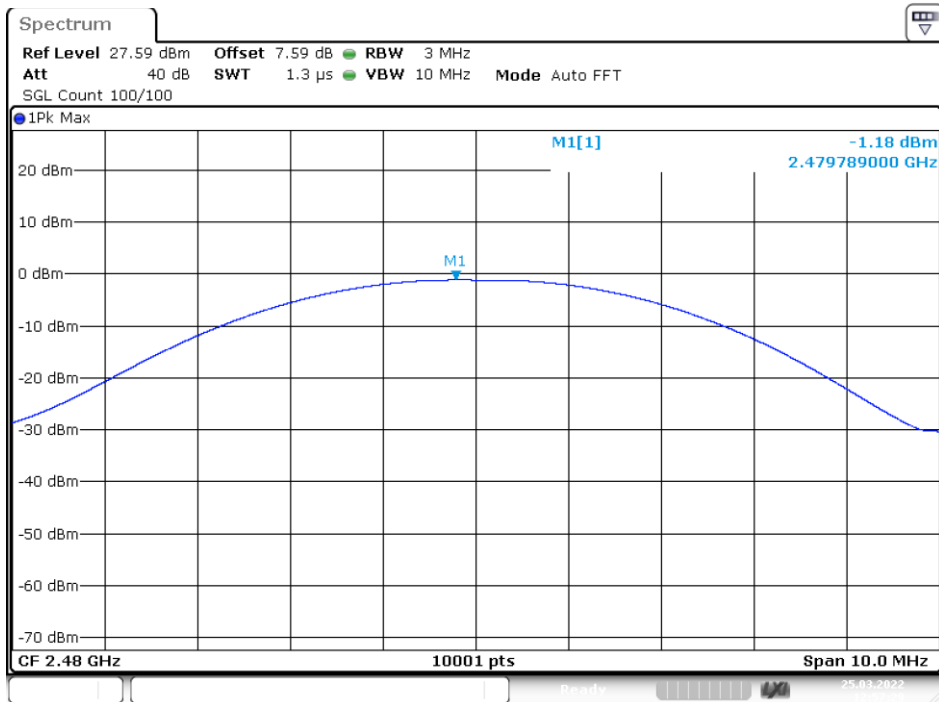

Date: 25.MAR.2022 12:57:29

Report No.: E01A22030472F00501
 Spectrum Detector: PK
 Test By: Best
 Test Result: PASS
 Modulation: Π/4-DQPSK

52 of 78
 Test Date : 2022-03-25
 Temperature : 24 °C
 Humidity : 53 %

| Channel number | Channel Frequency (MHz) | Peak Power output(dBm) | Peak Power output(mW) | Peak Power Limit(mW) | Pass/Fail |
|----------------|-------------------------|------------------------|-----------------------|----------------------|-----------|
| 01 | 2402 | 1.99 | 1.581 | 125 | PASS |
| 40 | 2441 | 1.34 | 1.361 | 125 | PASS |
| 79 | 2480 | -1.39 | 0.726 | 125 | PASS |

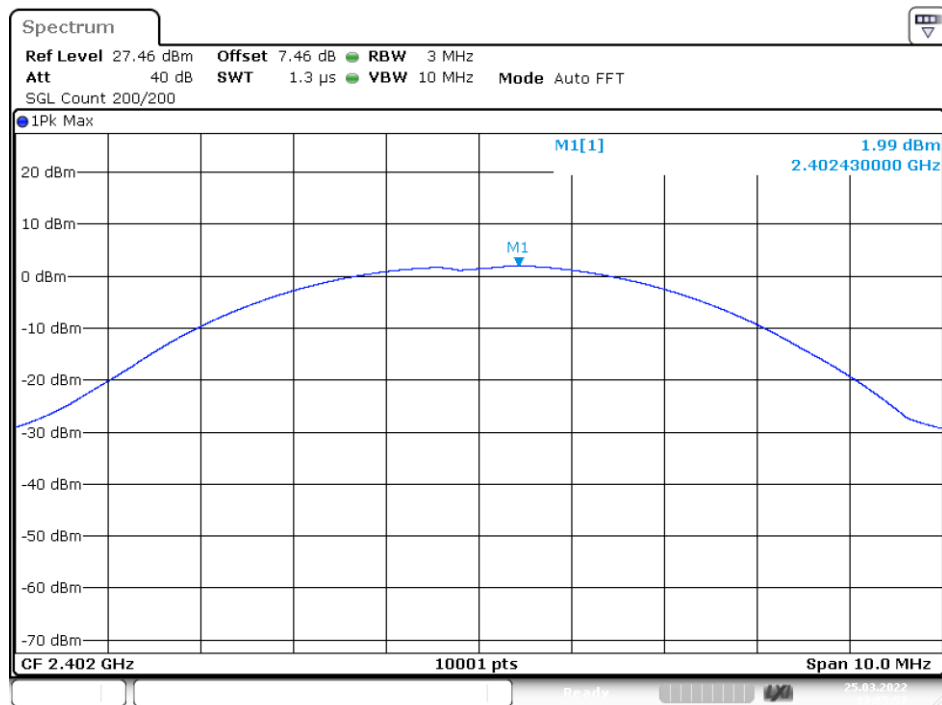

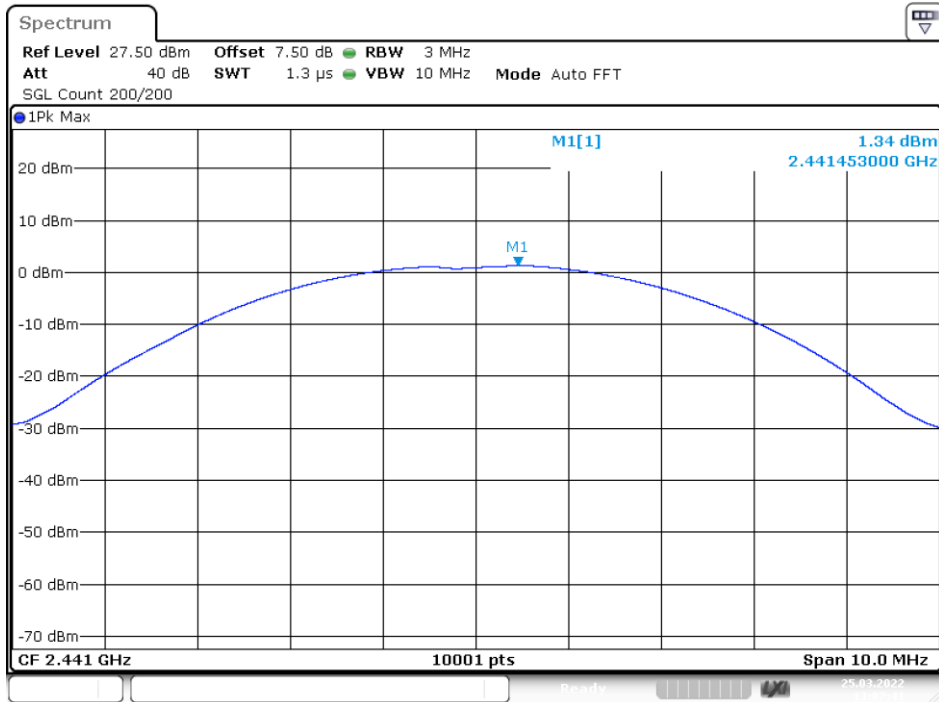

Date: 25.MAR.2022 13:07:41

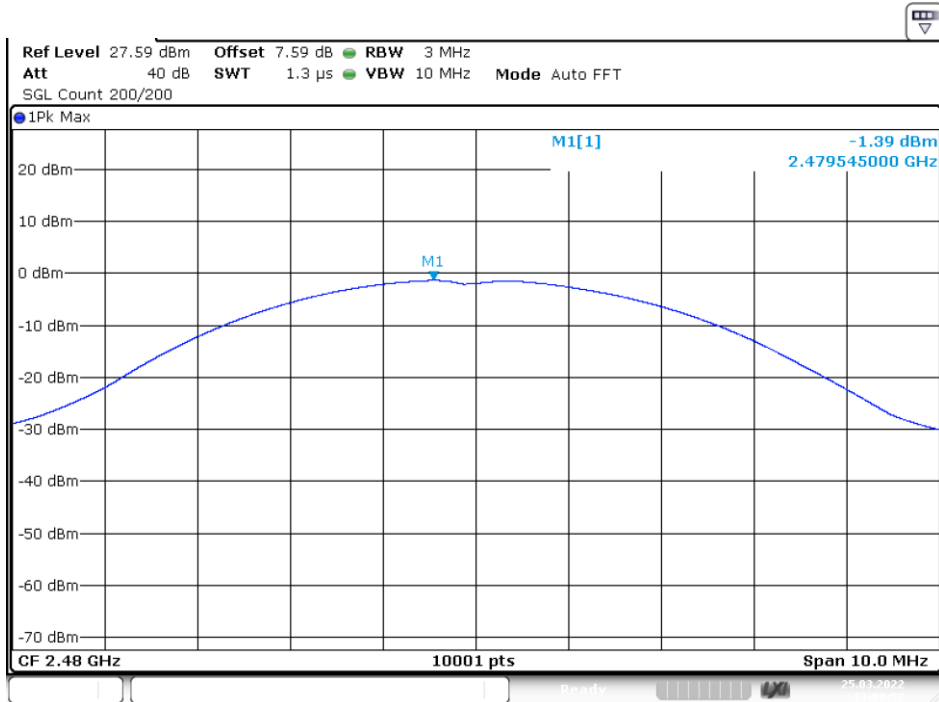

Date: 25.MAR.2022 13:08:52



Report No.: E01A22030472F00501

54 of 78

Spectrum Detector: PK
Test By: Best
Test Result: PASS
Modulation: 8DPSK

Test Date : 2022-03-23
Temperature : 24 °C
Humidity : 53 %

| Channel number | Channel Frequency (MHz) | Peak Power output(dBm) | Peak Power output(mW) | Peak Power Limit(mW) | Pass/Fail |
|----------------|-------------------------|------------------------|-----------------------|----------------------|-----------|
| 01 | 2402 | 1.93 | 1.560 | 125 | PASS |
| 40 | 2441 | 1.2 | 1.318 | 125 | PASS |
| 79 | 2480 | -1.47 | 0.713 | 125 | PASS |

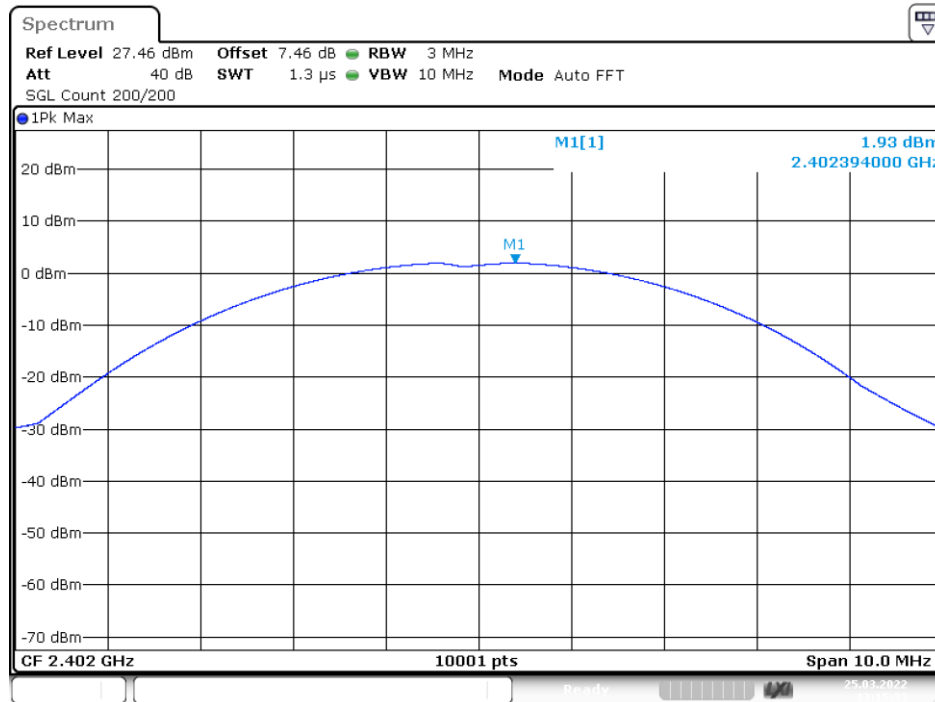

Date: 25.MAR.2022 13:15:32

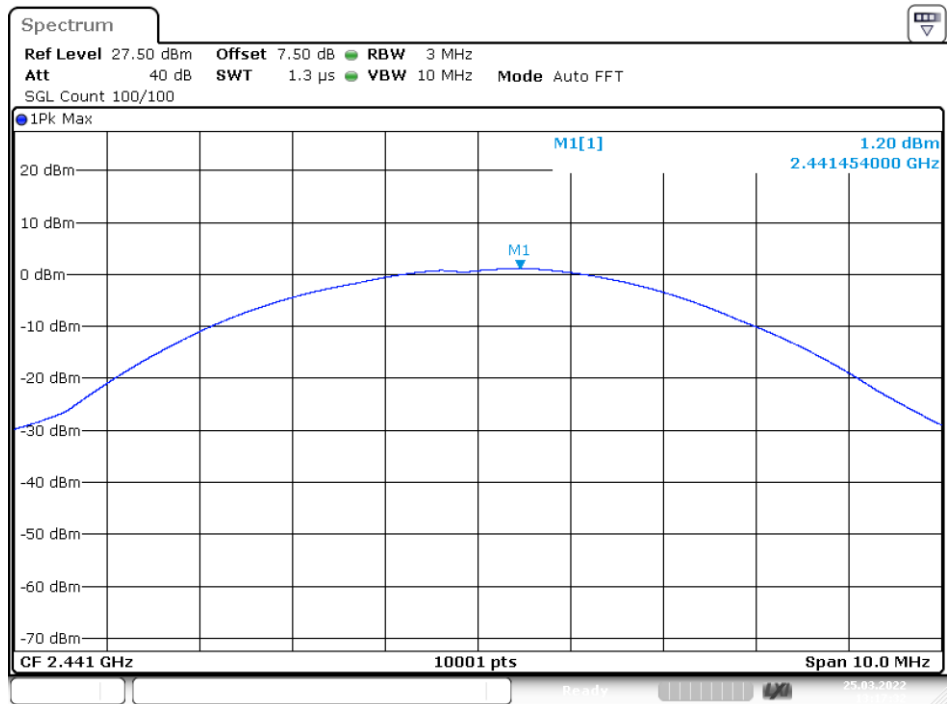

Date: 25.MAR.2022 13:17:32

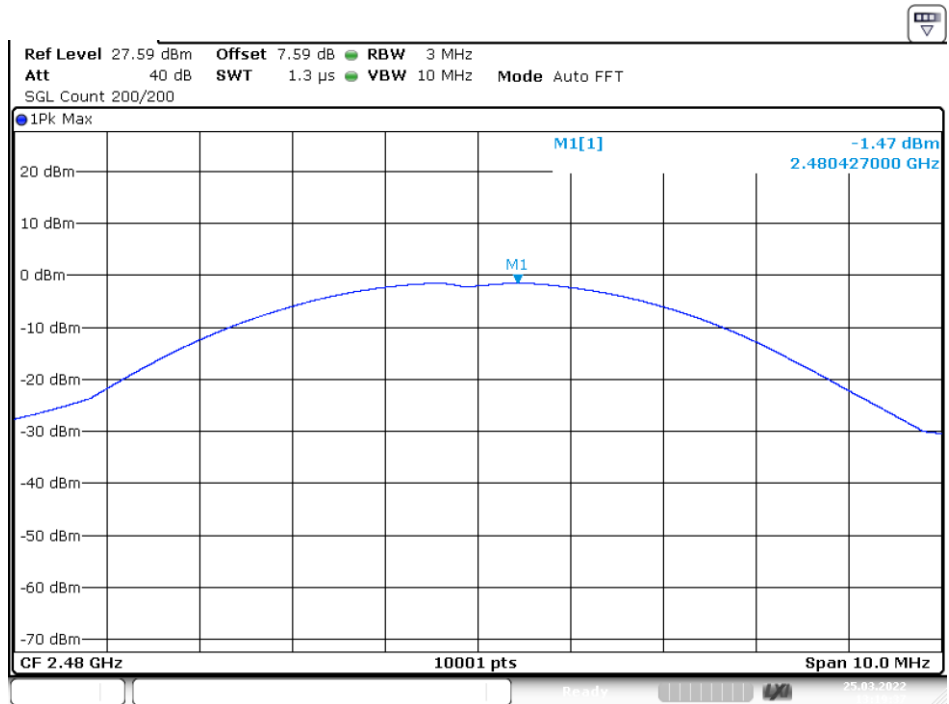

Date: 25.MAR.2022 13:19:37

13. Band EDGE test

13.1 Measurement Procedure

For Conducted Test

1. The transmitter output is connected to a spectrum analyzer. The resolution bandwidth is set to 100KHz. The video bandwidth is set to 300KHz.
2. The spectrum from 30MHz to 26 GHz is investigated with the transmitter set to the lowest, middle, and highest channels.

| EMI Test Receiver | Setting |
|-------------------|----------|
| Attenuation | Auto |
| RBW | 100KHz |
| VBW | 300KHz |
| Detector | Peak |
| Trace | Max hold |

For Radiated emission Test

The EUT was placed on a styrofoam table which is 1.5m above ground plane.

The measurement procedure at the band edges was simplified by performing the measurement in just one plot. Both, the in-band-emission and the unwanted emission were encompassed by the span. After trace stabilization, the maximum peak was determined by a peak detector and the value was marked by an appropriate limit line. The second limit line, which is 20dB below the first, marks the limit for the emissions in the unrestricted band. A maximum-peak-detector marks the highest emission in the unrestricted band next to the band edge.

The measurements were performed at the lower end of the 2.4GHz band.

Use the following spectrum analyzer settings:

For Restricted Band, When spectrum scanned above 1GHz setting resolution bandwidth 1MHz, video bandwidth 3MHz:

| EMI Test Receiver | Setting |
|-------------------|----------|
| Attenuation | Auto |
| RBW | 1MHz |
| VBW | 3MHz |
| Detector | Peak |
| Trace | Max hold |

For Non-Restricted Band, When spectrum scanned above 1GHz setting resolution bandwidth 100KHz, video bandwidth 300KHz:

| EMI Test Receiver | Setting |
|-------------------|----------|
| Attenuation | Auto |
| RBW | 100KHz |
| VBW | 300KHz |
| Detector | Peak |
| Trace | Max hold |

13.2 Test SET-UP (Block Diagram of Configuration)

For Conducted Test

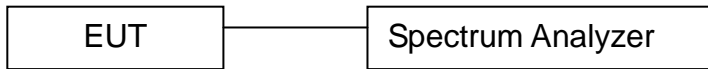

For Radiated emission Test

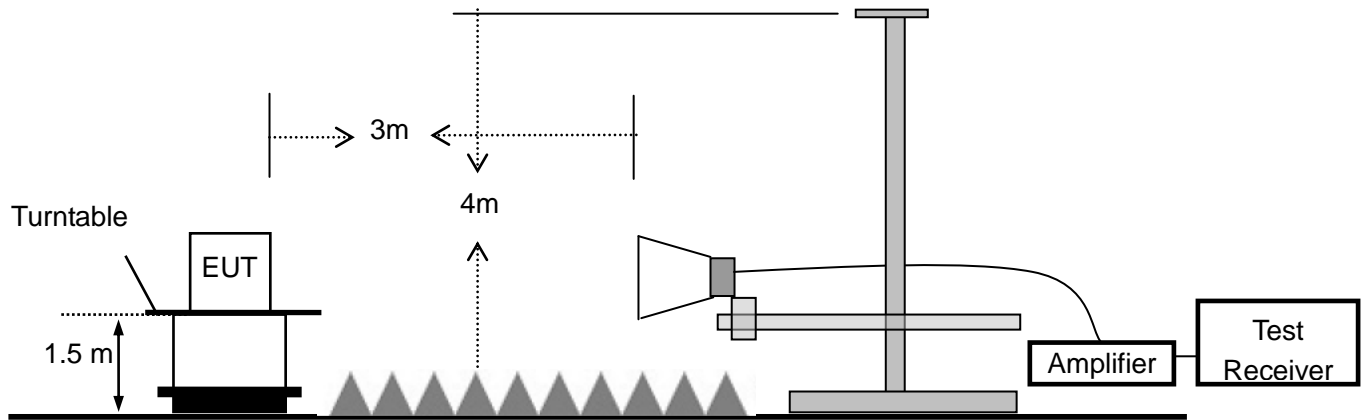

13.3 Measurement Equipment Used:

For Conducted Test

| EQUIPMENT TYPE | MFR | MODEL NUMBER | SERIAL NUMBER | CALIBRATED UNTIL |
|-------------------|--------------------|--------------|---------------|------------------|
| Spectrum Analyzer | Rohde & Schwarz | FSV40 | US40240623 | 2022-05-20 |
| Coaxial Cable | Gigalink Microwave | ZT40 | 19022092 | 2022-05-20 |
| Antenna Connector | ARTHUR-YANG | 2244-N1TG1 | N/A | 2022-05-20 |

Remark: The temporary antenna connector is soldered on the PCB board in order to perform conducted tests and this temporary antenna connector is listed in the equipment list.

For Radiated emission Test

| Item | Equipment | Manufacturer | Model No. | Serial No. | Calibrated Until |
|------|------------------------------|--------------------|-----------------------|-----------------|------------------|
| 1 | Signal Analyzer | Rohde & Schwarz | FSV40 | US40240623 | 2022-05-20 |
| 2 | Broadband RF Power Amplifier | AEROFLEX | AEROFLEX100KHz-40G Hz | J1013130524 001 | 2022-05-20 |
| 3 | DRG Horn Antenna | A.H.SYSTEMS | SAS-574 | J2031090612 123 | 2022-05-21 |
| 4 | RF Cable | Gigalink Microwave | ZT40-2.92J-2.92J-2m | N/A | 2022-05-21 |
| 5 | RF Cable | Gigalink Microwave | ZT40-2.92J-2.92J-0.3m | N/A | 2022-05-21 |

13.4 Measurement Results:

Refer to attached data chart.

| | | | |
|--------------------|------|---------------|------------|
| Spectrum Detector: | PK | Test Date : | 2022-03-25 |
| Test By: | Best | Temperature : | 24 °C |
| Test Result: | PASS | Humidity : | 53 % |

1. Conducted Test

For Non-Hopping Mode:

| Frequency (MHz) | Modulation | Peak Power Output(dBm) | Emission(dBm) | Result of Band edge(dBc) | Band edge Limit(dBc) |
|-----------------|------------|------------------------|---------------|--------------------------|----------------------|
| 2326.9 | GFSK | 2.09 | -41.43 | 43.52 | >20dBc |
| 2497.6 | pi/4-DQPSK | -2.12 | -43.32 | 41.20 | >20dBc |
| 2377.8 | 8DPSK | 2.21 | 41.12 | -38.91 | >20dBc |
| 2496.3 | GFSK | -1.42 | -42.79 | 41.37 | >20dBc |
| 2332.4 | pi/4-DQPSK | -0.70 | -41.82 | 41.12 | >20dBc |
| 2498.3 | 8DPSK | -4.28 | -42.00 | 37.72 | >20dBc |

Test plots of GFSK

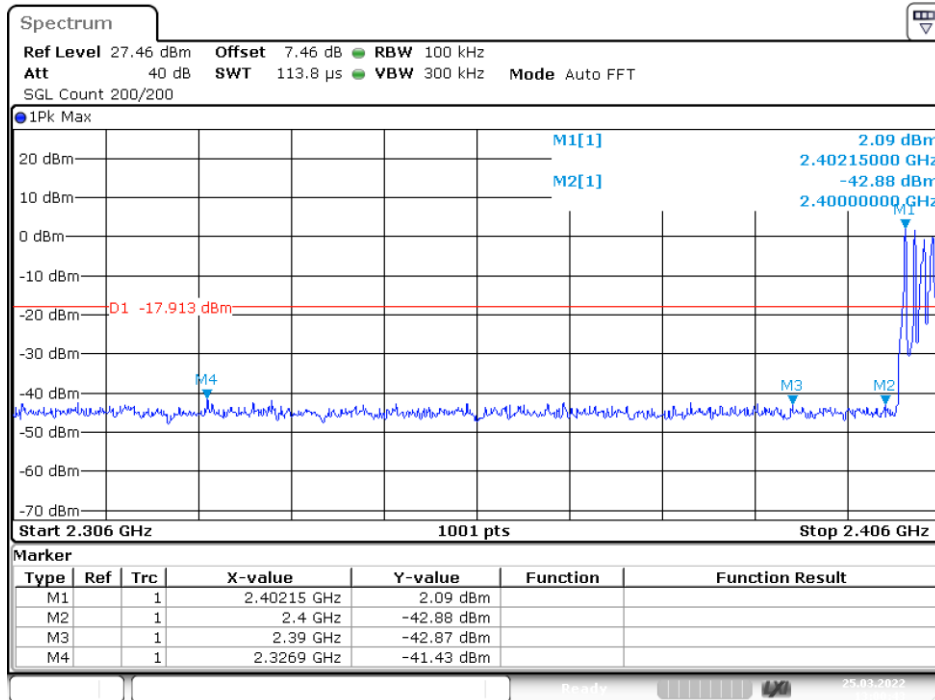

Date: 25.MAR.2022 13:00:42

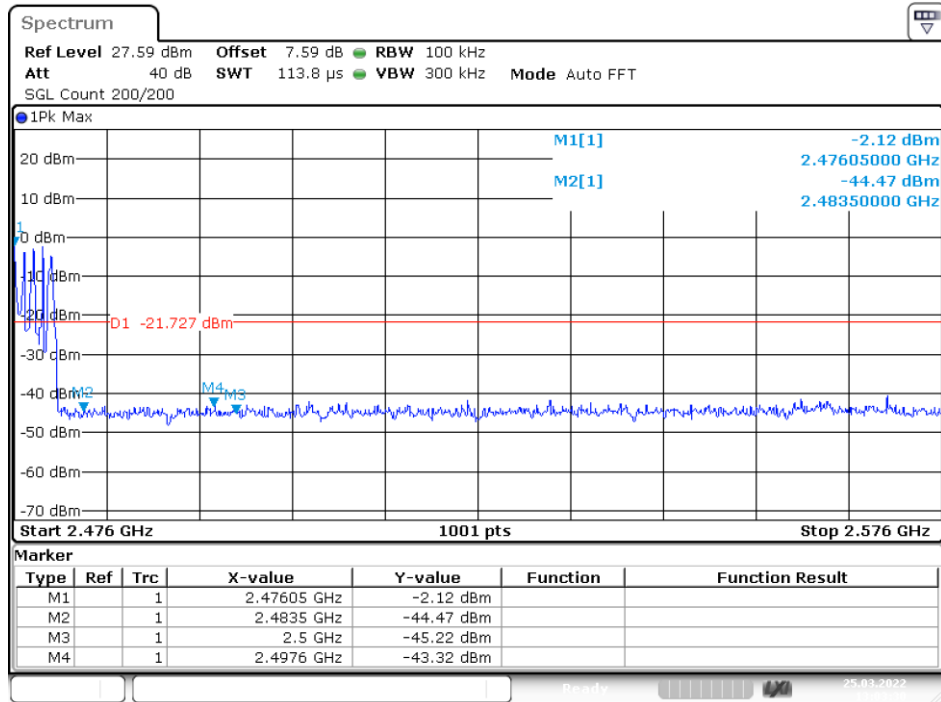

Test plots of pi/4-DQPSK

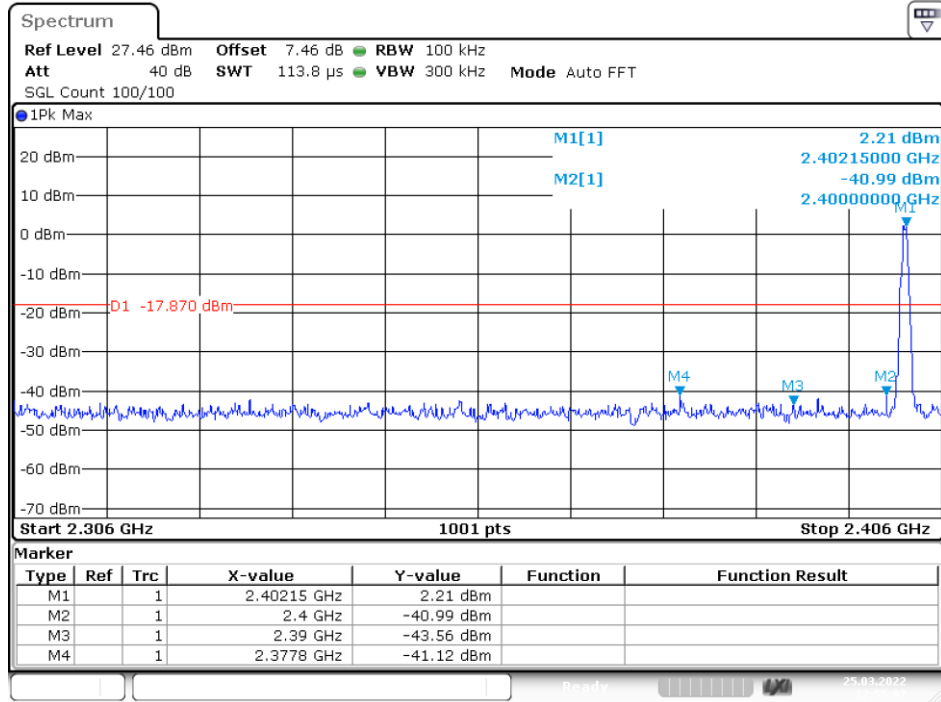

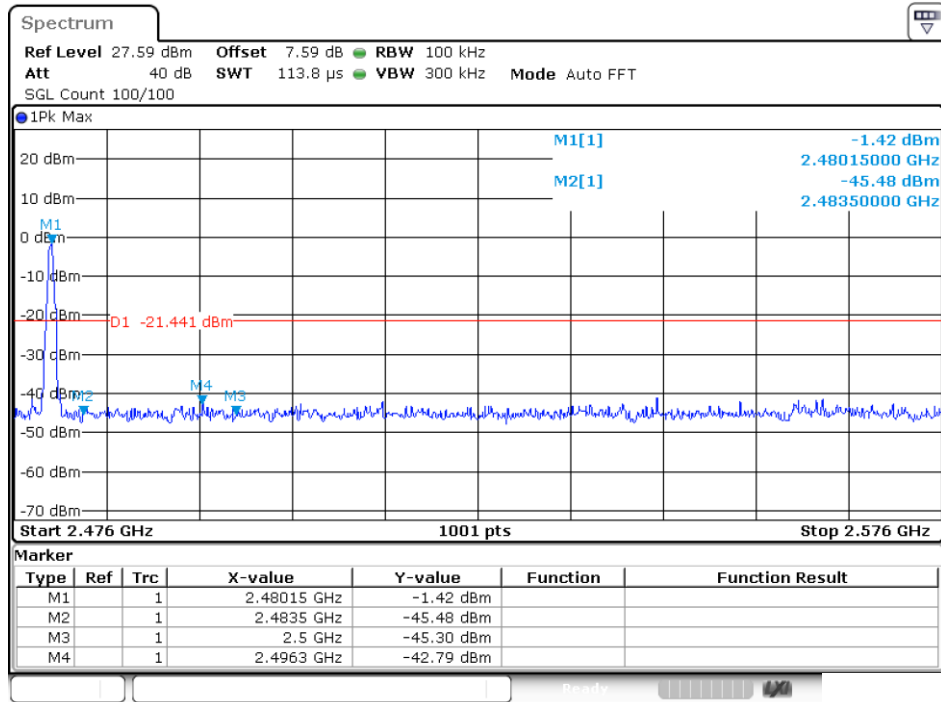

Date: 25.MAR.2022 12:57:58

Test plots of 8DPSK

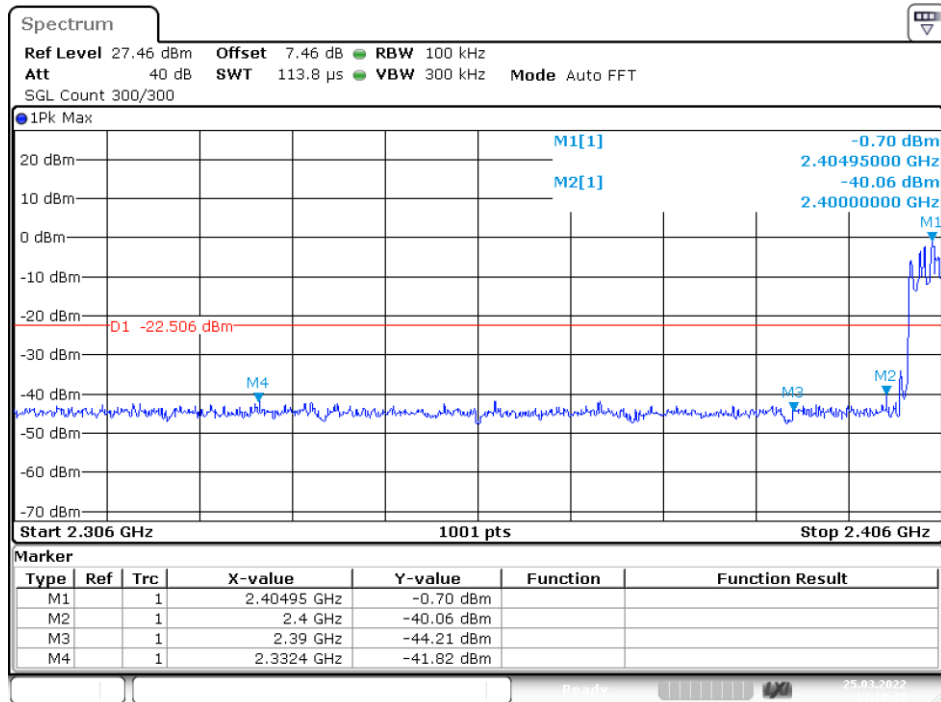

Date: 25.MAR.2022 13:10:44

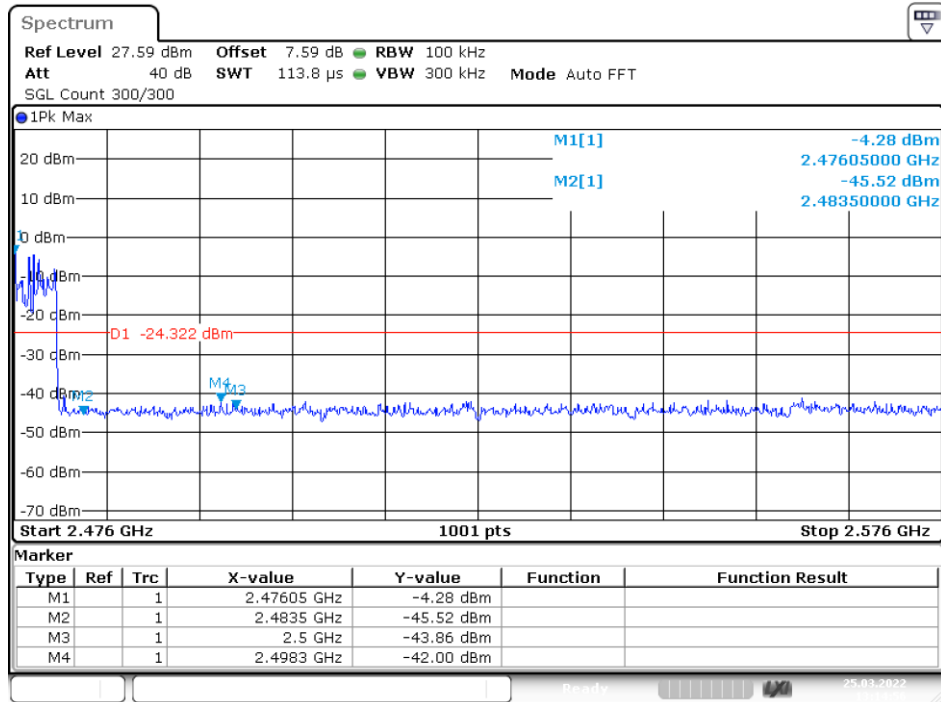

Date: 25.MAR.2022 13:14:56

For Hopping Mode:

| Frequency (MHz) | Modulation | Peak Power Output(dBm) | Emission(dBm) | Result of Band edge(dF) | Band edge |
|-----------------|------------|------------------------|---------------|-------------------------|-----------|
| 2354.5 | GFSK | 1.54 | -41.98 | 43.52 | >20dBc |
| 2499.8 | pi/4-DQPSK | -3.18 | -41.59 | 38.41 | >20dBc |
| 2385 | 8DPSK | -2.55 | -41.86 | 39.31 | >20dBc |
| 2493.4 | GFSK | -4.03 | -41.90 | 37.87 | >20dBc |
| 2354.2 | pi/4-DQPSK | 0.57 | -41.80 | 42.37 | >20dBc |
| 2493.9 | 8DPSK | -3.34 | -42.29 | 38.95 | >20dBc |

Test plots of GFSK

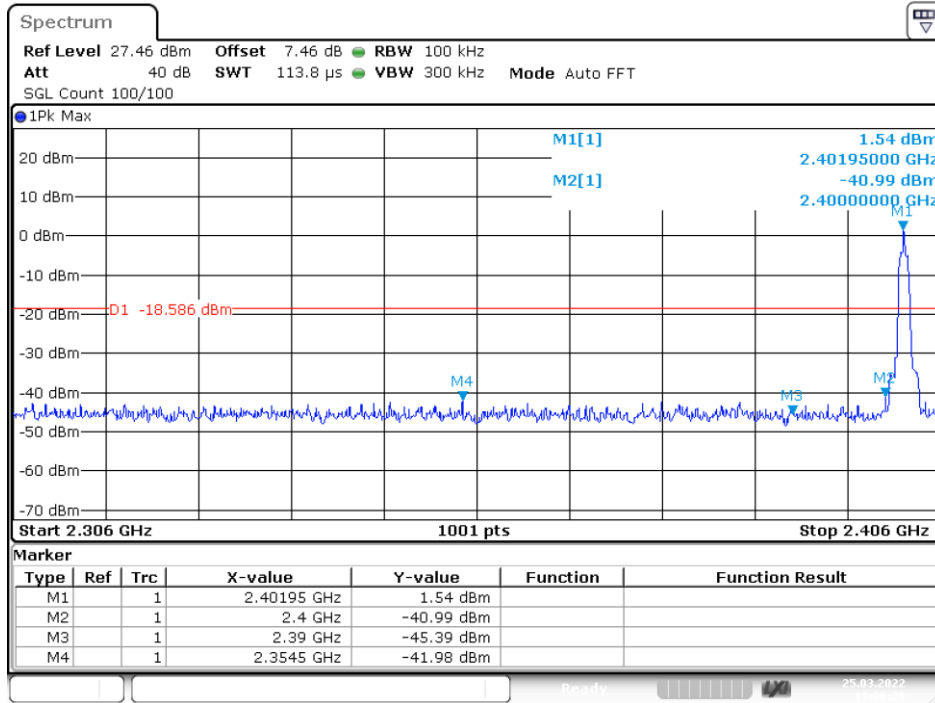

Date: 25.MAR.2022 13:06:28

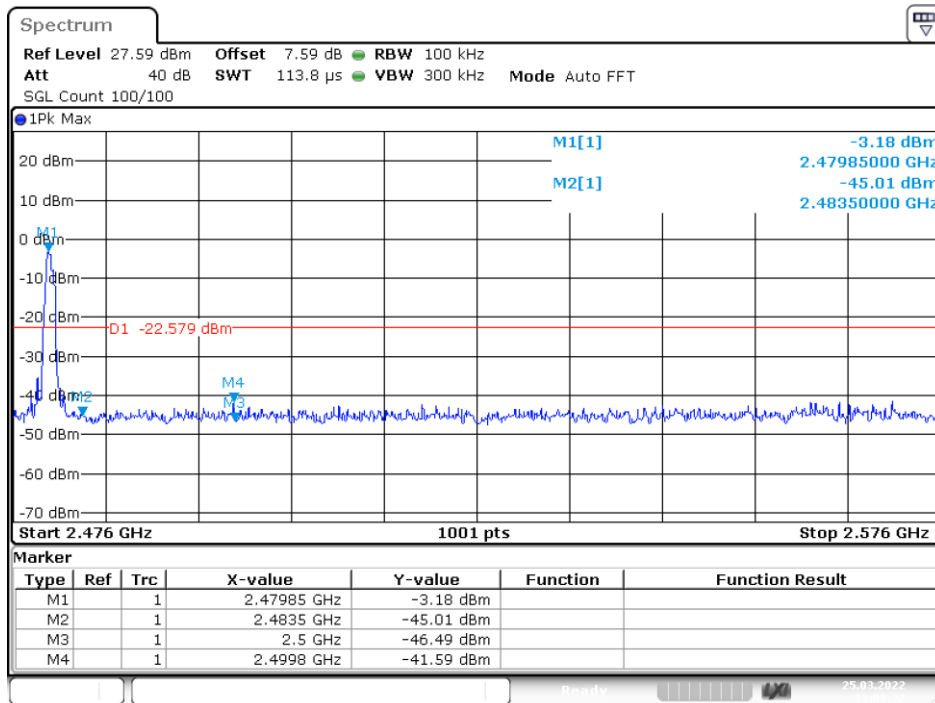

Date: 25.MAR.2022 13:09:22

Test plots of pi/4-DQPSK

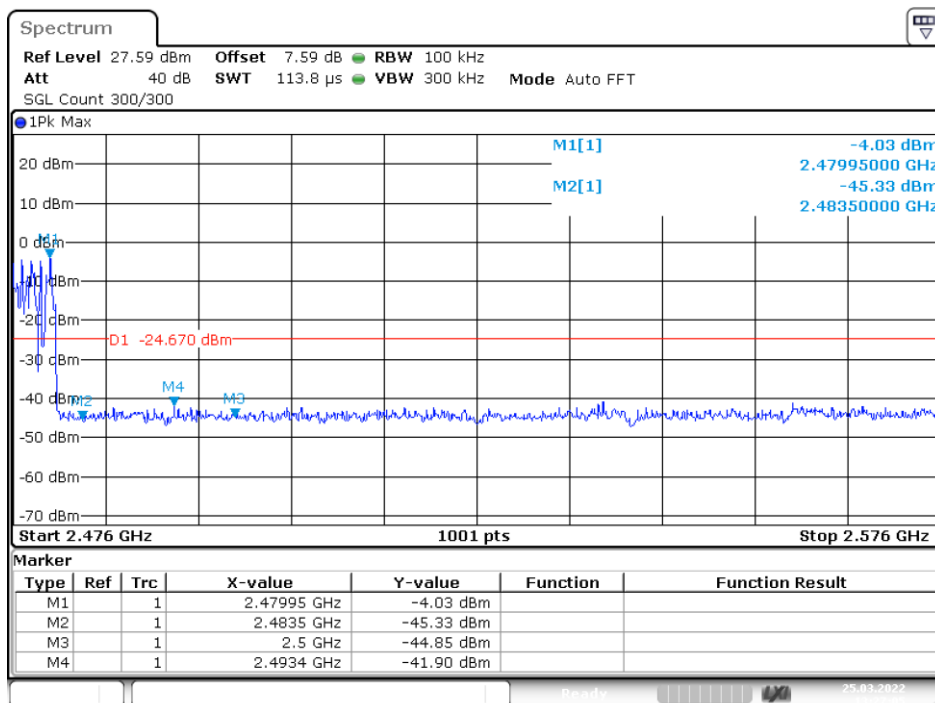
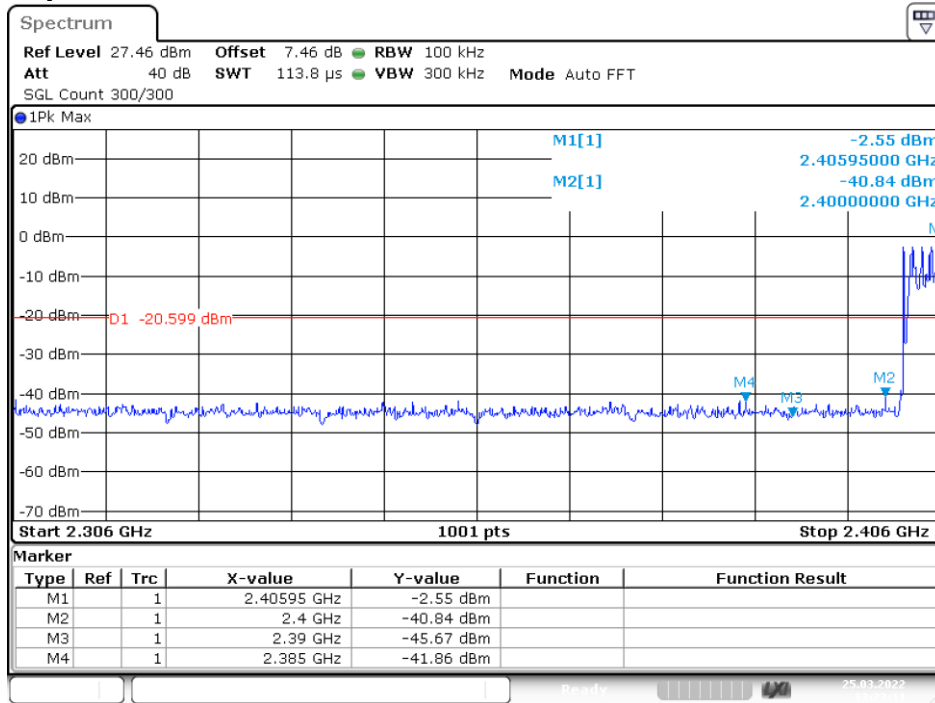

Test plots of 8DPSK

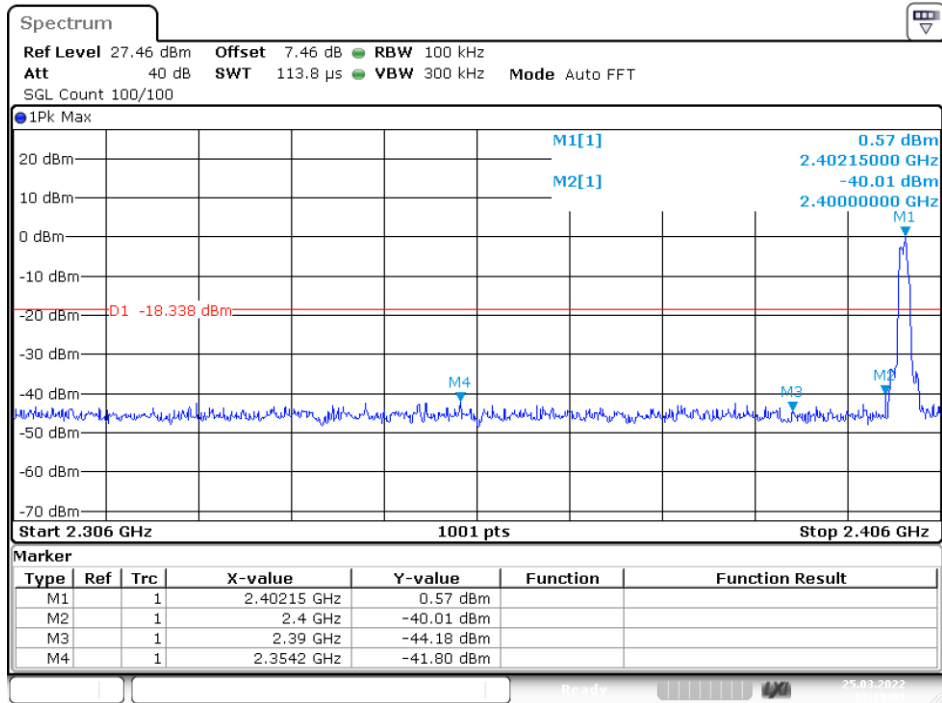

Date: 25.MAR.2022 13:19:01

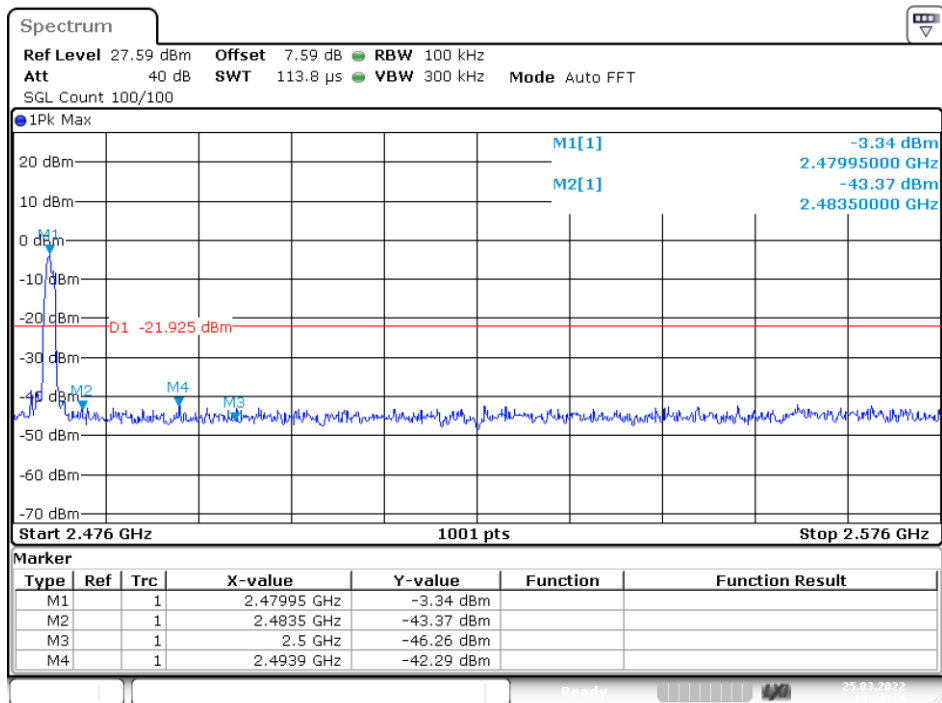

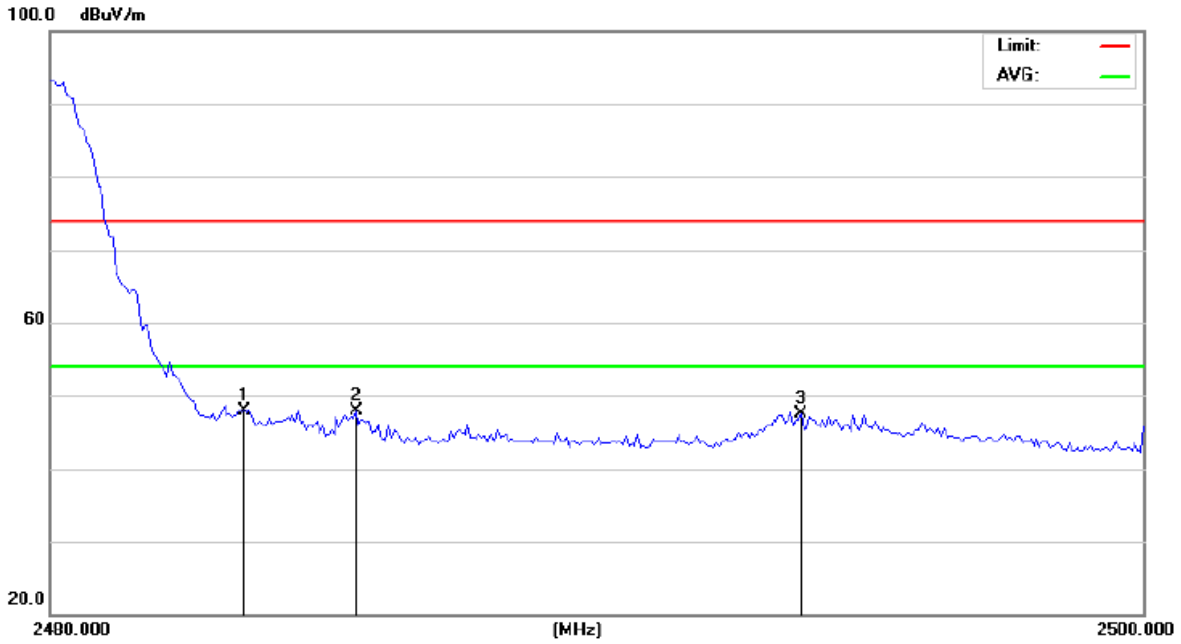

Site 843 Polarization: **Vertical** Temperature: 26.5(C)
 Limit: FCC Part 15 C 3m Above1G(Peak) Power: AC 120V/60Hz Humidity: 60.6 %
 Mode: DSS(TX2480)
 Note:

| No. | Mk. | Freq. MHz | Reading Level dBuV | Correct Factor dB | Measure- ment dBuV/m | Limit dB/m | Over dB | Antenna Height cm | Table Degree | Comment |
|-----|-----|--------------|--------------------------|-------------------------|----------------------------|---------------|------------|-------------------------|-----------------|---------|
| 1 | * | 2483.500 | 52.14 | -4.19 | 47.95 | 74.00 | -26.05 | peak | | |
| 2 | | 2485.584 | 52.12 | -4.18 | 47.94 | 74.00 | -26.06 | peak | | |
| 3 | | 2493.733 | 51.71 | -4.14 | 47.57 | 74.00 | -26.43 | peak | | |

*:Maximum data x:Over limit !:over margin

<Reference Only

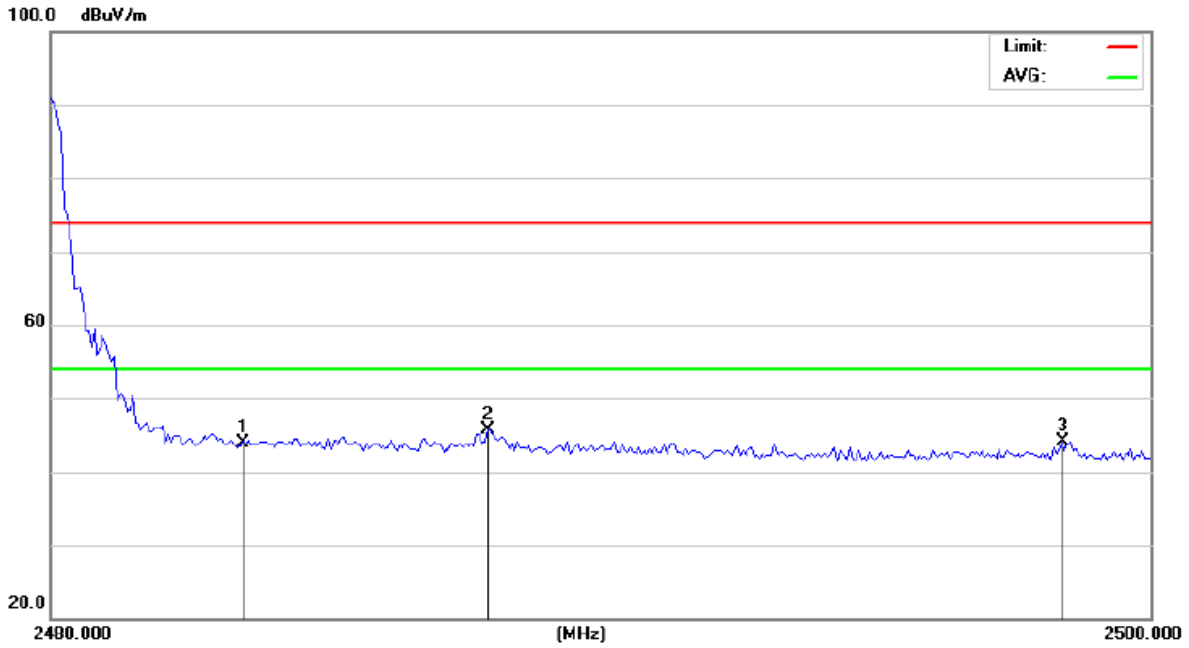

Site 843 Polarization: *Horizontal* Temperature: 26.5(C)
 Limit: FCC Part 15 C 3m Above1G(Peak) Power: AC 120V/60Hz Humidity: 60.6 %
 Mode: Hopping
 Note:

| No. | Mk. | Freq. | Reading Level | Correct Factor | Measurement | Limit | Over | Antenna Height | Table Degree | |
|-----|-----|----------|---------------|----------------|-------------|-------|--------|----------------|--------------|---------|
| | | MHz | dBuV | dB | dBuV/m | dB/m | dB | cm | degree | Comment |
| 1 | | 2483.500 | 48.12 | -4.19 | 43.93 | 74.00 | -30.07 | peak | | |
| 2 | * | 2487.931 | 49.78 | -4.16 | 45.62 | 74.00 | -28.38 | peak | | |
| 3 | | 2498.394 | 48.28 | -4.10 | 44.18 | 74.00 | -29.82 | peak | | |

*:Maximum data x:Over limit !:over margin

(Reference Only)

14. Antenna Application

14.1 Antenna requirement

The EUT'S antenna is met the requirement of FCC part 15C section 15.203 and 15.247.

FCC part 15C section 15.247 requirements:

Systems operating in the 2402-2480MHz band that are used exclusively for fixed, point-to-point operations may employ transmitting antennas with directional gain greater than 6dBi provided the maximum peak output power of the intentional radiator is reduced by 1dB for every 3dB that the directional gain of the antenna exceeds 6dBi.

14.2 Result

The EUT's antenna, permanent attached antenna, used a PCB antenna and integrated on PCB, The antenna's gain is 0 dBi and meets the requirement..



APPENDIX (Photos of EUT)

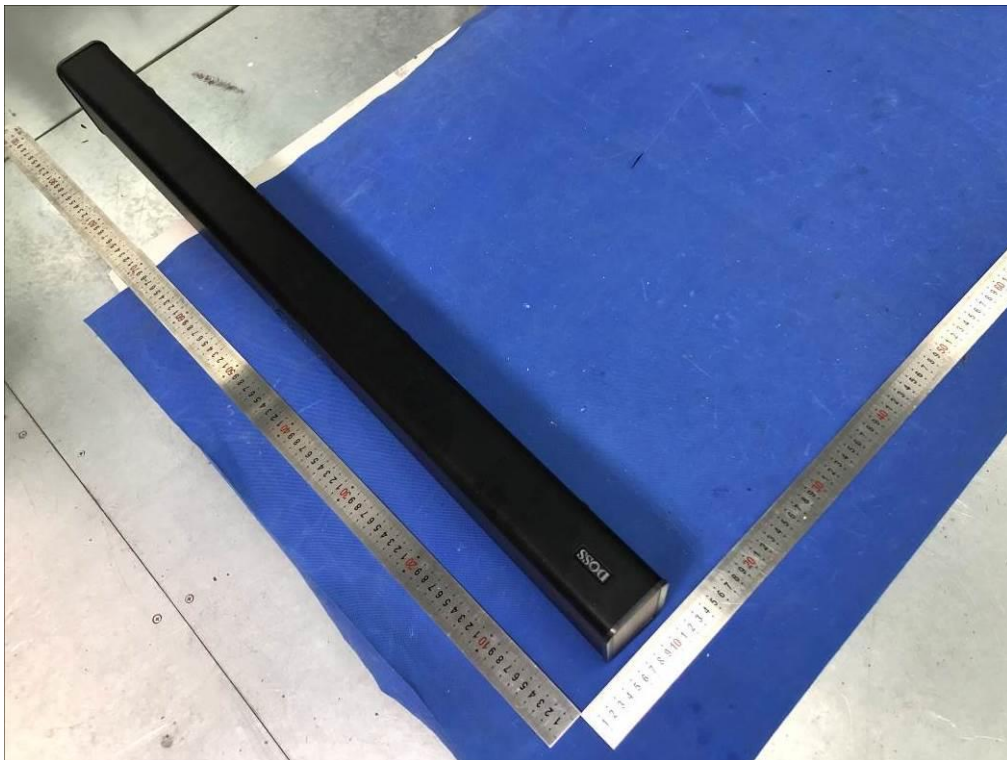

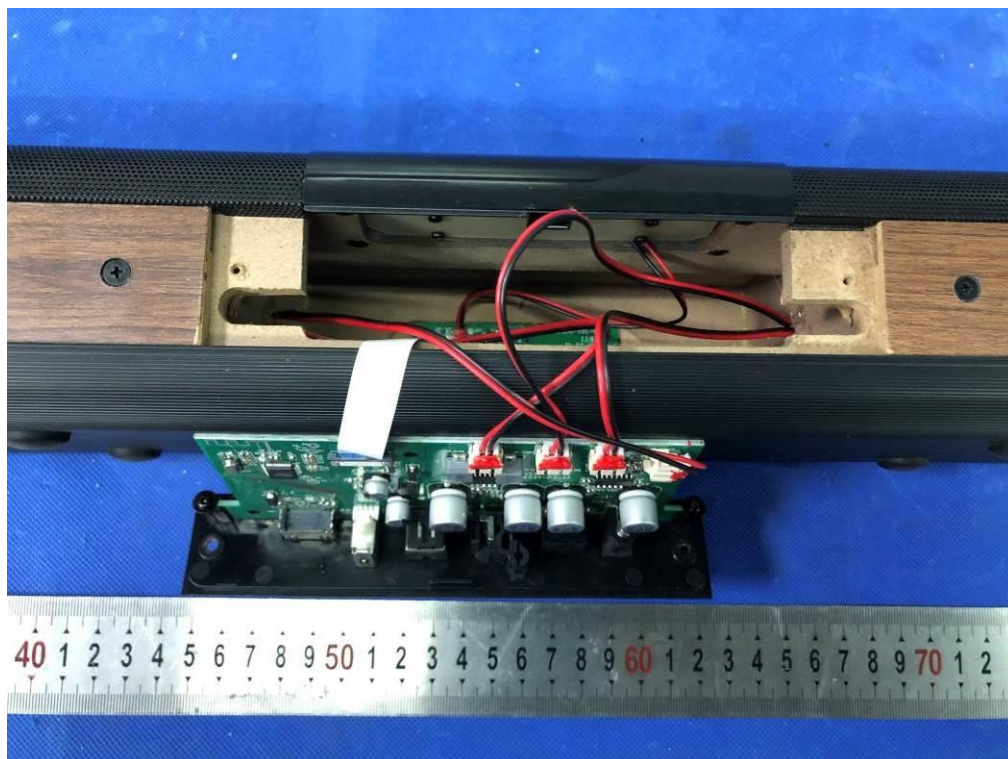

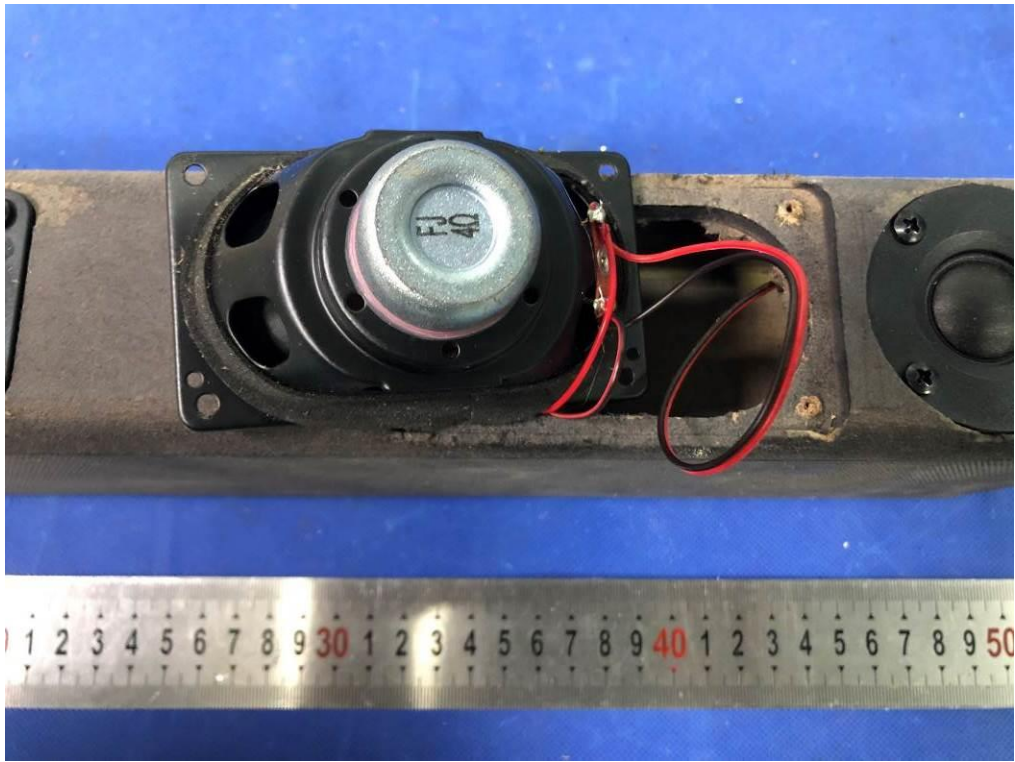

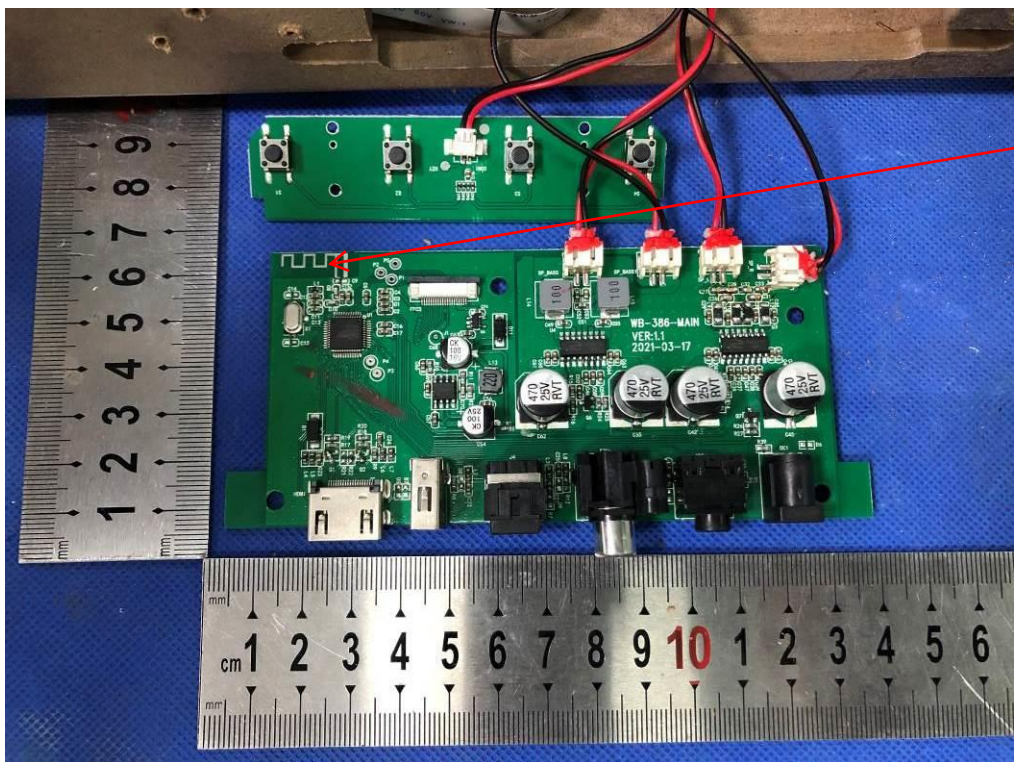

ANT

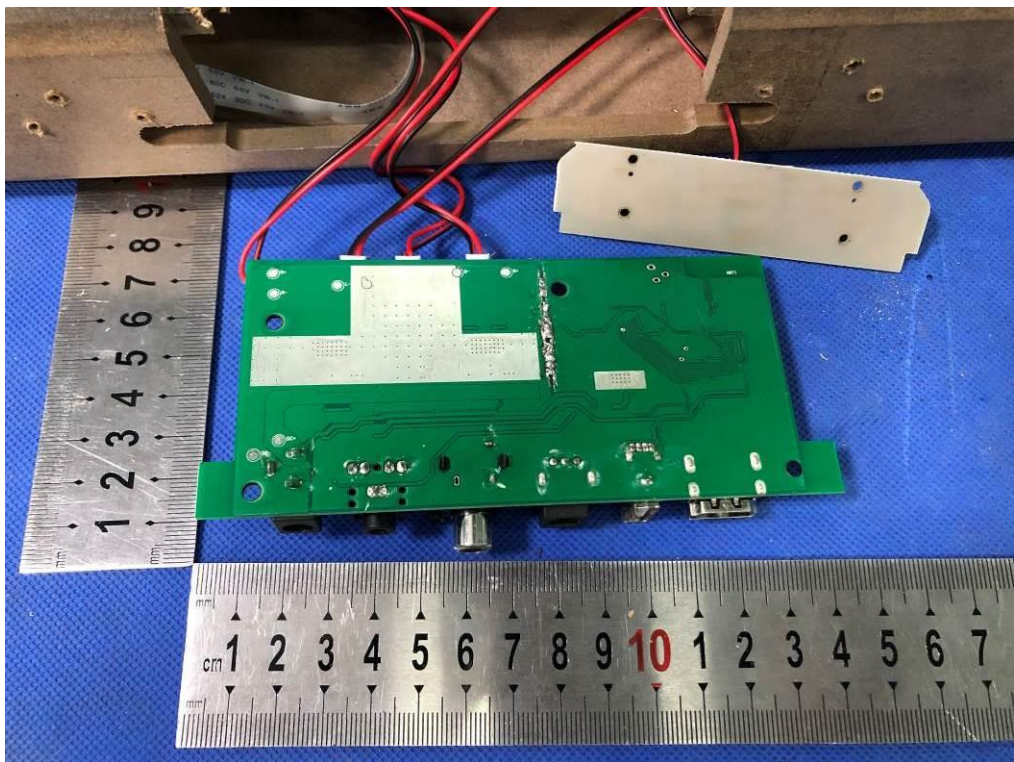

-----The end of report-----