

FCC Test Report

Report No.: RF160407E10A

FCC ID: WBV-AP550

Test Model: AP550

Received Date: Apr. 07, 2016

Test Date: May 07 ~ Jun. 22, 2016

Issued Date: Jun. 29, 2016

Applicant: Aerohive Networks Inc.

Address: 1011 McCarthy Blvd, Milpitas, CA 95035, USA

Issued By: Bureau Veritas Consumer Products Services (H.K.) Ltd., Taoyuan Branch

Lab Address: E-2, No.1, Li Hsin 1st Road, Hsinchu Science Park, Hsinchu City 300, Taiwan R.O.C.

Test Location (1): E-2, No.1, Li Hsin 1st Road, Hsinchu Science Park, Hsinchu City 300, Taiwan R.O.C.

Test Location (2): No. 49, Ln. 206, Wende Rd., Shangshan Tsuen, Chiung Lin Hsiang, Hsin Chu Hsien 307, Taiwan R.O.C.



This report is for your exclusive use. Any copying or replication of this report to or for any other person or entity, or use of our name or trademark, is permitted only with our prior written permission. This report sets forth our findings solely with respect to the test samples identified herein. The results set forth in this report are not indicative or representative of the quality or characteristics of the lot from which a test sample was taken or any similar or identical product specifically and expressly noted. Our report includes all of the tests requested by you and the results thereof based upon the information that you provided to us. You have 60 days from date of issuance of this report to notify us of any material error or omission caused by our negligence, provided, however, that such notice shall be in writing and shall specifically address the issue you wish to raise. A failure to raise such issue within the prescribed time shall constitute your unqualified acceptance of the completeness of this report, the tests conducted and the correctness of the report contents. Unless specific mention, the uncertainty of measurement has been explicitly taken into account to declare the compliance or non-compliance to the specification. The report must not be used by the client to claim product certification, approval, or endorsement by TAF or any government agencies.

Table of Contents

Release Control Record	4
1 Certificate of Conformity	5
2 Summary of Test Results	6
2.1 Measurement Uncertainty.....	6
2.2 Modification Record.....	6
3 General Information	7
3.1 General Description of EUT.....	7
3.2 Description of Test Modes.....	14
3.2.1 Test Mode Applicability and Tested Channel Detail.....	15
3.3 Duty Cycle of Test Signal.....	22
3.4 Description of Support Units.....	23
3.4.1 Configuration of System under Test.....	23
3.5 General Description of Applied Standards.....	24
4 Test Types and Results	25
4.1 Radiated Emission and Bandedge Measurement.....	25
4.1.1 Limits of Radiated Emission and Bandedge Measurement.....	25
4.1.2 Test Instruments.....	26
4.1.3 Test Procedures.....	28
4.1.4 Deviation from Test Standard.....	28
4.1.5 Test Set Up.....	29
4.1.6 EUT Operating Conditions.....	29
4.1.7 Test Results.....	30
4.2 Conducted Emission Measurement.....	180
4.2.1 Limits of Conducted Emission Measurement.....	180
4.2.2 Test Instruments.....	180
4.2.3 Test Procedures.....	181
4.2.4 Deviation from Test Standard.....	181
4.2.5 Test Setup.....	181
4.2.6 EUT Operating Conditions.....	181
4.2.7 Test Results.....	182
4.3 Transmit Power Measurement.....	190
4.3.1 Limits of Transmit Power Measurement.....	190
4.3.2 Test Setup.....	190
4.3.3 Test Instruments.....	190
4.3.4 Test Procedure.....	190
4.3.5 Deviation from Test Standard.....	190
4.3.6 EUT Operating Conditions.....	190
4.3.7 Test Result.....	191
4.4 Occupied Bandwidth Measurement.....	244
4.4.1 Test Setup.....	244
4.4.2 Test Instruments.....	244
4.4.3 Test Procedure.....	244
4.4.4 Test Result.....	245
4.5 Peak Power Spectral Density Measurement.....	257
4.5.1 Limits of Peak Power Spectral Density Measurement.....	257
4.5.2 Test Setup.....	257
4.5.3 Test Instruments.....	257
4.5.4 Test Procedures.....	258
4.5.5 Deviation from Test Standard.....	258
4.5.6 EUT Operating Conditions.....	258
4.5.7 Test Results.....	259
4.6 Frequency Stability.....	279
4.6.1 Limits of Frequency Stability Measurement.....	279

4.6.2	Test Setup.....	279
4.6.3	Test Instruments	279
4.6.4	Test Procedure	279
4.6.5	Deviation from Test Standard	279
4.6.6	EUT Operating Condition	279
4.6.7	Test Results	280
4.7	6dB Bandwidth Measurement.....	282
4.7.1	Limits of 6dB Bandwidth Measurement.....	282
4.7.2	Test Setup.....	282
4.7.3	Test Instruments	282
4.7.4	Test Procedure	282
4.7.5	Deviation from Test Standard	282
4.7.6	EUT Operating Condition	282
4.7.7	Test Results	283
5	Pictures of Test Arrangements.....	291
	Appendix – Information on the Testing Laboratories	292

Release Control Record

Issue No.	Description	Date Issued
RF160407E10A	Original release	Jun. 29, 2016

1 Certificate of Conformity

Product: Access Point

Brand: Aerohive

Test Model: AP550

Sample Status: Engineering sample

Applicant: Aerohive Networks Inc.

Test Date: May 07 ~ Jun. 22, 2016

Standards: 47 CFR FCC Part 15, Subpart E (Section 15.407)
ANSI C63.10:2013

The above equipment has been tested by **Bureau Veritas Consumer Products Services (H.K.) Ltd., Taoyuan Branch**, and found compliance with the requirement of the above standards. The test record, data evaluation & Equipment Under Test (EUT) configurations represented herein are true and accurate accounts of the measurements of the sample's EMC characteristics under the conditions specified in this report.

Prepared by : Celine Chou , **Date:** Jun. 29, 2016
Celine Chou / Specialist

Approved by :  , **Date:** Jun. 29, 2016
May Chen / Manager

2 Summary of Test Results

47 CFR FCC Part 15, Subpart E (Section 15.407)			
FCC Clause	Test Item	Result	Remarks
15.407(b)(6)	AC Power Conducted Emissions	Pass	Meet the requirement of limit. Minimum passing margin is -14.03dB at 0.18125MHz.
15.407(b) (1/2/3/4(i/ii)/6)	Radiated Emissions & Band Edge Measurement	Pass	Meet the requirement of limit. Minimum passing margin is -0.1dB at 5466.00MHz, 5390.00MHz, 5414.10MHz, 5150.00MHz and 5350.00MHz.
15.407(a)(1/2/3)	Max Average Transmit Power	Pass	Meet the requirement of limit.
---	Occupied Bandwidth Measurement	-	Reference only.
15.407(a)(1/2/3)	Peak Power Spectral Density	Pass	Meet the requirement of limit.
15.407(g)	Frequency Stability	Pass	Meet the requirement of limit.
15.203	Antenna Requirement	Pass	Antenna connector is i-pex not a standard connector.

2.1 Measurement Uncertainty

Where relevant, the following measurement uncertainty levels have been estimated for tests performed on the EUT as specified in CISPR 16-4-2:

Measurement	Frequency	Expanded Uncertainty (k=2) (\pm)
Conducted Emissions at mains ports	150kHz ~ 30MHz	1.83 dB
Radiated Emissions up to 1 GHz	30MHz ~ 200MHz	5.31 dB
	200MHz ~ 1000MHz	3.40 dB
Radiated Emissions above 1 GHz	1GHz ~ 18GHz	3.73 dB
	18GHz ~ 40GHz	4.11 dB

2.2 Modification Record

There were no modifications required for compliance.

3 General Information

3.1 General Description of EUT (DFS Band)

Product	Access Point
Brand	Aerohive
Test Model	AP550
Status of EUT	Engineering sample
Power Supply Rating	12Vdc from adapter 55Vdc from PoE
Modulation Type	256QAM, 64QAM, 16QAM, QPSK, BPSK for OFDM
Modulation Technology	OFDM
Transfer Rate	802.11a: 54.0/ 48.0/ 36.0/ 24.0/ 18.0/ 12.0/ 9.0/ 6.0Mbps 802.11n: up to 600.0Mbps 802.11ac: up to 1733.3Mbps
Operating Frequency	5260 ~ 5320MHz, 5500 ~ 5720MHz
Number of Channel	5260 ~ 5320MHz: 802.11a, 802.11n (HT20), 802.11ac (VHT20): 4 802.11n (HT40), 802.11ac (VHT40): 2 802.11ac (VHT80): 1 5500 ~ 5720MHz: 802.11a, 802.11n (HT20), 802.11ac (VHT20): 12, 802.11n (HT40), 802.11ac (VHT40): 6, 802.11ac (VHT80): 3
Output Power	Radio 1: 4TX CDD Mode 5260 ~ 5320MHz: 128.338mW 5500 ~ 5720MHz: 209.472mW 4TX TxBF Mode 5260 ~ 5320MHz: 67.494mW 5500 ~ 5720MHz: 69.211mW 2TX CDD Mode 5260 ~ 5320MHz: 216.399mW 5500 ~ 5720MHz: 208.999mW 2TX TxBF Mode 5260 ~ 5320MHz: 127.712mW 5500 ~ 5720MHz: 132.544mW

Output Power	Radio 2: 4TX CDD Mode 5260 ~ 5320MHz: 137.271mW 5500 ~ 5720MHz: 246.926mW 4TX TxBF Mode 5260 ~ 5320MHz: 66.750mW 5500 ~ 5720MHz: 68.515mW 2TX CDD Mode 5260 ~ 5320MHz: 205.746mW 5500 ~ 5720MHz: 235.989mW 2TX TxBF Mode 5260 ~ 5320MHz: 133.114mW 5500 ~ 5720MHz: 129.959mW
Antenna Type	Refer to Note
Antenna Connector	i-pex
Accessory Device	N/A
Data Cable Supplied	N/A

Note:

1. This report is prepared for FCC class II permissive change. The difference compared with the original report (BV ADT report no.: RF160407E10-1) is adding 5.26GHz to 5.32GHz and 5.50GHz to 5.72GHz by software.
2. There are three radios for the EUT.

Radio	Function
Radio 1	WLAN 2.4G & 5G
Radio 2	WLAN 5G
Radio 3	BT EDR & BT LE

3. The EUT incorporates a MIMO function. Physically, the EUT provides 4 completed transmitters and 4 receivers.

Modulation Mode	TX Function	Beamforming
Radio 1		
802.11a	2TX/4TX	Not Support
802.11n (HT20)	2TX/4TX	Support
802.11n (HT40)	2TX/4TX	Support
802.11ac (VHT20)	2TX/4TX	Support
802.11ac (VHT40)	2TX/4TX	Support
802.11ac (VHT80)	2TX/4TX	Support
Radio 2		
802.11a	2TX/4TX	Not Support
802.11n (HT20)	2TX/4TX	Support
802.11n (HT40)	2TX/4TX	Support
802.11ac (VHT20)	2TX/4TX	Support
802.11ac (VHT40)	2TX/4TX	Support
802.11ac (VHT80)	2TX/4TX	Support

*The modulation and bandwidth are similar for 802.11n mode for HT20 / HT40 and 802.11ac mode for VHT20 / VHT40, therefore investigated worst case to representative mode in test report. (Final test mode refer section 3.2.1)

4. The following antennas were provided to the EUT.

Radio	Ant. No.	Chain No.	Antenna Gain(dBi) (Including cable loss)	Frequency range	Antenna Type	Connector Type	*Cable Loss(dB)	*Cable Length	
1	Ant. 1	Chain 0	4.00	2.4~2.4835GHz	PIFA	i-pex	0.39	95	
			5.84	5.15~5.25GHz					
			5.92	5.25~5.35GHz					
			5.29	5.47~5.725GHz					
			5.78	5.725~5.85GHz					
1	Ant. 2	Chain 1	3.41	2.4~2.4835GHz	PIFA	i-pex	0.41	100	
			5.88	5.15~5.25GHz					
			5.36	5.25~5.35GHz					
			5.84	5.47~5.725GHz					
			5.72	5.725~5.85GHz					
1	Ant. 3	Chain 2	3.77	2.4~2.4835GHz	PIFA	i-pex	0.65	160	
			5.64	5.15~5.25GHz					
			5.49	5.25~5.35GHz					
			5.31	5.47~5.725GHz					
			5.75	5.725~5.85GHz					
1	Ant. 4	Chain 3	3.94	2.4~2.4835GHz	PIFA	i-pex	0.83	203	
			5.39	5.15~5.25GHz					
			5.91	5.25~5.35GHz					
			5.67	5.47~5.725GHz					
			5.92	5.725~5.85GHz					
2	Ant. 5	Chain 0	5.11	5.15~5.25GHz	PIFA	i-pex	0.4	98	
			5.50	5.25~5.35GHz					
			5.08	5.47~5.725GHz					
			5.40	5.725~5.85GHz					
	2	Ant. 6	Chain 1	5.55	5.15~5.25GHz	PIFA	i-pex	0.32	78
				5.02	5.25~5.35GHz				
				5.30	5.47~5.725GHz				
				5.94	5.725~5.85GHz				
2	Ant. 7	Chain 2	5.62	5.15~5.25GHz	PIFA	i-pex	0.6	148	
			5.78	5.25~5.35GHz					
			5.67	5.47~5.725GHz					
			5.64	5.725~5.85GHz					
2	Ant. 8	Chain 3	5.23	5.15~5.25GHz	PIFA	i-pex	0.87	213	
			5.69	5.25~5.35GHz					
			5.75	5.47~5.725GHz					
			5.73	5.725~5.85GHz					
2	Ant. 10	Chain 0	4.70	5.15~5.25GHz	Dipole	i-pex	0.23	57	
			5.31	5.25~5.35GHz					
			5.68	5.47~5.725GHz					
			4.74	5.725~5.85GHz					
2	Ant. 11	Chain 1	5.15	5.15~5.25GHz	Dipole	i-pex	0.44	107	
			5.25	5.25~5.35GHz					
			4.50	5.47~5.725GHz					
			5.20	5.725~5.85GHz					
2	Ant. 12	Chain 2	4.53	5.15~5.25GHz	Dipole	i-pex	0.68	167	
			4.55	5.25~5.35GHz					
			4.42	5.47~5.725GHz					
			5.21	5.725~5.85GHz					
2	Ant. 13	Chain 3	4.87	5.15~5.25GHz	Dipole	i-pex	0.93	227	
			4.69	5.25~5.35GHz					
			4.95	5.47~5.725GHz					
			4.41	5.725~5.85GHz					
3	Ant. 9	Chain 0	5.83	2.4~2.4835GHz	Dipole	i-pex	0.36	148	

* For 2TX: the worst antenna for each mode please refers to section 3.2.1

5. The power setting are list as below:

Radio 1, 4TX, CDD						
	802.11a	802.11ac (VHT20)		802.11ac (VHT40)		802.11ac (VHT80)
CH 52	47	47	CH 54	59	CH 58	36
CH 60	47	47	CH 62	44	CH 106	38
CH 64	47	47	CH 102	48	CH 122	67
CH 100	47	47	CH 110	58	CH 138 For U-NII-2C	67
CH 116	46	46	CH 134	58	CH 138 For U-NII-3	67
CH 140	46	46	CH 142 For U-NII-2C	58		
CH 144 For U-NII-2C	46	46	CH 142 For U-NII-3	58		
CH 144 For U-NII-3	46	46				
Radio 1, 2TX, CDD						
	802.11a	802.11ac (VHT20)		802.11ac (VHT40)		802.11ac (VHT80)
CH 52	72	72	CH 54	82	CH 58	45
CH 60	72	72	CH 62	50	CH 106	48
CH 64	72	72	CH 102	55	CH 122	74
CH 100	73	73	CH 110	82	CH 138 For U-NII-2C	78
CH 116	73	73	CH 134	74	CH 138 For U-NII-3	78
CH 140	73	68	CH 142 For U-NII-2C	86		
CH 144 For U-NII-2C	73	73	CH 142 For U-NII-3	86		
CH 144 For U-NII-3	73	73				

Radio 2, 4TX, CDD						
	802.11a	802.11ac (VHT20)		802.11ac (VHT40)		802.11ac (VHT80)
CH 52	49	49	CH 54	60	CH 58	46
CH 60	48	48	CH 62	59	CH 106	46
CH 64	48	48	CH 102	52	CH 122	70
CH 100	48	48	CH 110	59	CH 138 For U-NII-2C	75
CH 116	47	47	CH 134	59	CH 138 For U-NII-3	75
CH 140	48	48	CH 142 For U-NII-2C	59		
CH 144 For U-NII-2C	48	48	CH 142 For U-NII-3	59		
CH 144 For U-NII-3	48	48				
Radio 2, 2TX, CDD						
	802.11a	802.11ac (VHT20)		802.11ac (VHT40)		802.11ac (VHT80)
CH 52	77	77	CH 54	86	CH 58	47
CH 60	77	77	CH 62	63	CH 106	47
CH 64	77	77	CH 102	62	CH 122	77
CH 100	74	74	CH 110	88	CH 138 For U-NII-2C	85
CH 116	75	76	CH 134	74	CH 138 For U-NII-3	85
CH 140	74	74	CH 142 For U-NII-2C	88		
CH 144 For U-NII-2C	76	76	CH 142 For U-NII-3	88		
CH 144 For U-NII-3	76	76				

Radio 1, 4TX, TxBF					
	802.11ac (VHT20)		802.11ac (VHT40)		802.11ac (VHT80)
CH 52	47	CH 54	46	CH 58	36
CH 60	47	CH 62	44	CH 106	38
CH 64	47	CH 102	46	CH 122	46
CH 100	47	CH 110	46	CH 138 For U-NII-2C	46
CH 116	46	CH 134	46	CH 138 For U-NII-3	46
CH 140	46	CH 142 For U-NII-2C	46		
CH 144 For U-NII-2C	46	CH 142 For U-NII-3	46		
CH 144 For U-NII-3	46				
Radio 1, 2TX, TxBF					
	802.11ac (VHT20)		802.11ac (VHT40)		802.11ac (VHT80)
CH 52	72	CH 54	73	CH 58	45
CH 60	72	CH 62	50	CH 106	48
CH 64	72	CH 102	55	CH 122	73
CH 100	73	CH 110	73	CH 138 For U-NII-2C	76
CH 116	73	CH 134	73	CH 138 For U-NII-3	76
CH 140	68	CH 142 For U-NII-2C	73		
CH 144 For U-NII-2C	73	CH 142 For U-NII-3	73		
CH 144 For U-NII-3	73				

Radio 2, 4TX, TxBF					
	802.11ac (VHT20)		802.11ac (VHT40)		802.11ac (VHT80)
CH 52	49	CH 54	49	CH 58	46
CH 60	48	CH 62	48	CH 106	46
CH 64	48	CH 102	48	CH 122	48
CH 100	48	CH 110	48	CH 138 For U-NII-2C	48
CH 116	47	CH 134	48	CH 138 For U-NII-3	48
CH 140	48	CH 142 For U-NII-2C	48		
CH 144 For U-NII-2C	48	CH 142 For U-NII-3	48		
CH 144 For U-NII-3	48				

Radio 2, 2TX, TxBF					
	802.11ac (VHT20)		802.11ac (VHT40)		802.11ac (VHT80)
CH 52	77	CH 54	78	CH 58	47
CH 60	77	CH 62	63	CH 106	47
CH 64	77	CH 102	62	CH 122	76
CH 100	74	CH 110	76	CH 138 For U-NII-2C	76
CH 116	80	CH 134	74	CH 138 For U-NII-3	76
CH 140	74	CH 142 For U-NII-2C	76		
CH 144 For U-NII-2C	76	CH 142 For U-NII-3	76		
CH 144 For U-NII-3	76				

6. The EUT uses following adapter & PoE. (Support unit only)

Adapter	
Brand	DVE
Model	DSA-36PFH-12FUS
Input Power	100-240Vac, 50/60Hz, 1A
Output Power	12.0Vdc, 3.0A
Power Line	1.5m DC cable without core attached on adapter

PoE	
Brand	PowerDsine
Model	PD-9001GR/AT/AC
Input Power	100-240Vac, 50/60Hz, 0.67A
Output Power	55Vdc, 0.6A

3.2 Description of Test Modes

For 5260 ~ 5320MHz

4 channels are provided for 802.11a, 802.11n (HT20), 802.11ac (VHT20):

Channel	Frequency	Channel	Frequency
52	5260 MHz	60	5300 MHz
56	5280 MHz	64	5320 MHz

2 channels are provided for 802.11n (HT40), 802.11ac (VHT40):

Channel	Frequency	Channel	Frequency
54	5270 MHz	62	5310 MHz

1 channel is provided for 802.11ac (VHT80):

Channel	Frequency
58	5290 MHz

For 5500 ~ 5720MHz

12 channels are provided for 802.11a, 802.11n (HT20), 802.11ac (VHT20):

Channel	Frequency	Channel	Frequency
100	5500 MHz	124	5620 MHz
104	5520 MHz	128	5640 MHz
108	5540 MHz	132	5660 MHz
112	5560 MHz	136	5680 MHz
116	5580 MHz	140	5700 MHz
120	5600 MHz	144	5720 MHz

6 channels are provided for 802.11n (HT40), 802.11ac (VHT40):

Channel	Frequency	Channel	Frequency
102	5510 MHz	126	5630 MHz
110	5550 MHz	134	5670 MHz
118	5590 MHz	142	5710 MHz

3 channels are provided for 802.11ac (VHT80):

Channel	Frequency	Channel	Frequency
106	5530 MHz	122	5610 MHz
138	5690 MHz		

3.2.1 Test Mode Applicability and Tested Channel Detail

EUT CONFIGURE MODE	APPLICABLE TO				DESCRIPTION
	RE \geq 1G	RE<1G	PLC	APCM	
A	√	√	√	√	EUT with PoE mode
B	-	√	√	-	EUT with Adapter mode

Where **RE \geq 1G**: Radiated Emission above 1GHz & Bandedge Measurement
RE<1G: Radiated Emission below 1GHz
PLC: Power Line Conducted Emission
APCM: Antenna Port Conducted Measurement

Note:

- The EUT had been pre-tested on the positioned of each 2 axis. The worst case was following as below.
 - ◆ For the Radio 1 above 1GHz was found when positioned on X-plane.
 - ◆ For the Radio 2 above 1GHz was found when positioned on X-plane.
 - ◆ For the Radio 1 and Radio 2 below 1GHz was found when positioned on Y-plane.
- "-" means no effect.

Radiated Emission Test (Above 1GHz):

- Pre-Scan has been conducted to determine the worst-case mode from all possible combinations between available modulations, data rates and antenna ports (if EUT with antenna diversity architecture).
- Following channel(s) was (were) selected for the final test as listed below.

For Radio 1								
EUT CONFIGURE MODE	MODE	FREQ. BAND (MHz)	AVAILABLE CHANNEL	TESTED CHANNEL	MODULATION TECHNOLOGY	MODULATION TYPE	DATA RATE (Mbps)	MODE
A	802.11a	5260-5320	52 to 64	52, 60, 64	OFDM	BPSK	6.0	Radio 1, CDD (Ant. 1, 2, 3, 4)
A	802.11ac (VHT20)		52 to 64	52, 60, 64	OFDM	BPSK	6.5	
A	802.11ac (VHT40)		54 to 62	54, 62	OFDM	BPSK	13.5	
A	802.11ac (VHT80)		58	58	OFDM	BPSK	29.3	
A	802.11a		52 to 64	52, 60, 64	OFDM	BPSK	6.0	Radio 1, CDD (Ant. 1, 4)
A	802.11ac (VHT20)		52 to 64	52, 60, 64	OFDM	BPSK	6.5	
A	802.11ac (VHT40)		54 to 62	54, 62	OFDM	BPSK	13.5	
A	802.11ac (VHT80)		58	58	OFDM	BPSK	29.3	
A	802.11a	5500-5720	100 to 144	100, 116, 140, 144	OFDM	BPSK	6.0	Radio 1, CDD (Ant. 1, 2, 3, 4)
A	802.11ac (VHT20)		100 to 144	100, 116, 140, 144	OFDM	BPSK	6.5	
A	802.11ac (VHT40)		102 to 142	102, 110, 134, 142	OFDM	BPSK	13.5	
A	802.11ac (VHT80)		106 to 138	106, 122, 138	OFDM	BPSK	29.3	
A	802.11a		100 to 144	100, 116, 140, 144	OFDM	BPSK	6.0	Radio 1, CDD (Ant. 2, 4)
A	802.11ac (VHT20)		100 to 144	100, 116, 140, 144	OFDM	BPSK	6.5	
A	802.11ac (VHT40)		102 to 142	102, 110, 134, 142	OFDM	BPSK	13.5	
A	802.11ac (VHT80)		106 to 138	106, 122, 138	OFDM	BPSK	29.3	

For Radio 2								
EUT CONFIGURE MODE	MODE	FREQ. BAND (MHz)	AVAILABLE CHANNEL	TESTED CHANNEL	MODULATION TECHNOLOGY	MODULATION TYPE	DATA RATE (Mbps)	MODE
A	802.11a	5260-5320	52 to 64	52, 60, 64	OFDM	BPSK	6.0	Radio 2 with PIFA ant., CDD (Ant. 5, 6, 7, 8)
A	802.11ac (VHT20)		52 to 64	52, 60, 64	OFDM	BPSK	6.5	
A	802.11ac (VHT40)		54 to 62	54, 62	OFDM	BPSK	13.5	
A	802.11ac (VHT80)		58	58	OFDM	BPSK	29.3	
A	802.11a		52 to 64	52, 60, 64	OFDM	BPSK	6.0	Radio 2 with PIFA ant., CDD (Ant. 7, 8)
A	802.11ac (VHT20)		52 to 64	52, 60, 64	OFDM	BPSK	6.5	
A	802.11ac (VHT40)		54 to 62	54, 62	OFDM	BPSK	13.5	
A	802.11ac (VHT80)		58	58	OFDM	BPSK	29.3	
A	802.11a		52 to 64	52, 60, 64	OFDM	BPSK	6.0	Radio 2 with Dipole ant., CDD (Ant. 10, 11, 12, 13)
A	802.11ac (VHT20)		52 to 64	52, 60, 64	OFDM	BPSK	6.5	
A	802.11ac (VHT40)		54 to 62	54, 62	OFDM	BPSK	13.5	
A	802.11ac (VHT80)		58	58	OFDM	BPSK	29.3	
A	802.11a		52 to 64	52, 60, 64	OFDM	BPSK	6.0	Radio 2 with Dipole ant., CDD (Ant. 10, 11)
A	802.11ac (VHT20)		52 to 64	52, 60, 64	OFDM	BPSK	6.5	
A	802.11ac (VHT40)		54 to 62	54, 62	OFDM	BPSK	13.5	
A	802.11ac (VHT80)		58	58	OFDM	BPSK	29.3	
A	802.11a	5500-5720	100 to 144	100, 116, 140, 144	OFDM	BPSK	6.0	Radio 2 with PIFA ant., CDD (Ant. 5, 6, 7, 8)
A	802.11ac (VHT20)		100 to 144	100, 116, 140, 144	OFDM	BPSK	6.5	
A	802.11ac (VHT40)		102 to 142	102, 110, 134, 142	OFDM	BPSK	13.5	
A	802.11ac (VHT80)		106 to 138	106, 122, 138	OFDM	BPSK	29.3	
A	802.11a		100 to 144	100, 116, 140, 144	OFDM	BPSK	6.0	Radio 2 with PIFA ant., CDD (Ant. 7, 8)
A	802.11ac (VHT20)		100 to 144	100, 116, 140, 144	OFDM	BPSK	6.5	
A	802.11ac (VHT40)		102 to 142	102, 110, 134, 142	OFDM	BPSK	13.5	
A	802.11ac (VHT80)		106 to 138	106, 122, 138	OFDM	BPSK	29.3	
A	802.11a		100 to 144	100, 116, 140, 144	OFDM	BPSK	6.0	Radio 2 with Dipole ant., CDD (Ant. 10, 11, 12, 13)
A	802.11ac (VHT20)		100 to 144	100, 116, 140, 144	OFDM	BPSK	6.5	
A	802.11ac (VHT40)		102 to 142	102, 110, 134, 142	OFDM	BPSK	13.5	
A	802.11ac (VHT80)		106 to 138	106, 122, 138	OFDM	BPSK	29.3	
A	802.11a		100 to 144	100, 116, 140, 144	OFDM	BPSK	6.0	Radio 2 with Dipole ant., CDD (Ant. 10, 13)
A	802.11ac (VHT20)		100 to 144	100, 116, 140, 144	OFDM	BPSK	6.5	
A	802.11ac (VHT40)		102 to 142	102, 110, 134, 142	OFDM	BPSK	13.5	
A	802.11ac (VHT80)		106 to 138	106, 122, 138	OFDM	BPSK	29.3	

Radiated Emission Test (Below 1GHz):

- Pre-Scan has been conducted to determine the worst-case mode from all possible combinations between available modulations, data rates and antenna ports (if EUT with antenna diversity architecture).
- Following channel(s) was (were) selected for the final test as listed below.

For Radio 1								
EUT CONFIGURE MODE	MODE	FREQ. BAND (MHz)	AVAILABLE CHANNEL	TESTED CHANNEL	MODULATION TECHNOLOGY	MODULATION TYPE	DATA RATE (Mbps)	MODE
A, B	802.11ac (VHT40)	5260-5320	54 to 62	110	OFDM	BPSK	13.5	Radio 1, CDD (Ant. 1, 2, 3, 4)
	802.11ac (VHT40)	5500-5720	102 to 142		OFDM	BPSK	13.5	
For Radio 2								
EUT CONFIGURE MODE	MODE	FREQ. BAND (MHz)	AVAILABLE CHANNEL	TESTED CHANNEL	MODULATION TECHNOLOGY	MODULATION TYPE	DATA RATE (Mbps)	MODE
A, B	802.11ac (VHT40)	5260-5320	54 to 62	110	OFDM	BPSK	13.5	Radio 2 with PIFA ant., CDD (Ant. 5, 6, 7, 8)
	802.11ac (VHT40)	5500-5720	102 to 142		OFDM	BPSK	13.5	
A, B	802.11ac (VHT40)	5260-5320	54 to 62	110	OFDM	BPSK	13.5	Radio 2 with Dipole ant., CDD (Ant. 10, 11, 12, 13)
	802.11ac (VHT40)	5500-5720	102 to 142		OFDM	BPSK	13.5	

Power Line Conducted Emission Test:

- Pre-Scan has been conducted to determine the worst-case mode from all possible combinations between available modulations, data rates and antenna ports (if EUT with antenna diversity architecture).
- Following channel(s) was (were) selected for the final test as listed below.

For Radio 1								
EUT CONFIGURE MODE	MODE	FREQ. BAND (MHz)	AVAILABLE CHANNEL	TESTED CHANNEL	MODULATION TECHNOLOGY	MODULATION TYPE	DATA RATE (Mbps)	MODE
A, B	802.11ac (VHT40)	5260-5320	54 to 62	110	OFDM	BPSK	13.5	Radio 1, CDD (Ant. 1, 2, 3, 4)
	802.11ac (VHT40)	5500-5720	102 to 142		OFDM	BPSK	13.5	
For Radio 2								
EUT CONFIGURE MODE	MODE	FREQ. BAND (MHz)	AVAILABLE CHANNEL	TESTED CHANNEL	MODULATION TECHNOLOGY	MODULATION TYPE	DATA RATE (Mbps)	MODE
A, B	802.11ac (VHT40)	5260-5320	54 to 62	110	OFDM	BPSK	13.5	Radio 2 with Dipole ant., CDD (Ant. 10, 11, 12, 13)
	802.11ac (VHT40)	5500-5720	102 to 142		OFDM	BPSK	13.5	

Transmit Power Measurement:

- This item includes all test value of each mode, but only includes spectrum plot of worst value of each mode.
- Pre-Scan has been conducted to determine the worst-case mode from all possible combinations between available modulations, data rates and antenna ports (if EUT with antenna diversity architecture).
- Following channel(s) was (were) selected for the final test as listed below.

For Radio 1										
EUT CONFIGURE MODE	MODE	FREQ. BAND (MHz)	AVAILABLE CHANNEL	TESTED CHANNEL	MODULATION TECHNOLOGY	MODULATION TYPE	DATA RATE (Mbps)	MODE		
A	802.11a	5260-5320	52 to 64	52, 60, 64	OFDM	BPSK	6.0	Radio 1, CDD (Ant. 1, 2, 3, 4)		
A	802.11ac (VHT20)		52 to 64	52, 60, 64	OFDM	BPSK	6.5			
A	802.11ac (VHT40)		54 to 62	54, 62	OFDM	BPSK	13.5			
A	802.11ac (VHT80)		58	58	OFDM	BPSK	29.3			
A	802.11ac (VHT20)		52 to 64	52, 60, 64	OFDM	BPSK	6.5	Radio 1, TxBF (Ant. 1, 2, 3, 4)		
A	802.11ac (VHT40)		54 to 62	54, 62	OFDM	BPSK	13.5			
A	802.11ac (VHT80)		58	58	OFDM	BPSK	29.3			
A	802.11a		52 to 64	52, 60, 64	OFDM	BPSK	6.0			
A	802.11ac (VHT20)		52 to 64	52, 60, 64	OFDM	BPSK	6.5	Radio 1, CDD (Ant. 1, 4)		
A	802.11ac (VHT40)		54 to 62	54, 62	OFDM	BPSK	13.5			
A	802.11ac (VHT80)		58	58	OFDM	BPSK	29.3			
A	802.11ac (VHT20)		52 to 64	52, 60, 64	OFDM	BPSK	6.5			
A	802.11ac (VHT40)		54 to 62	54, 62	OFDM	BPSK	13.5	Radio 1, TxBF (Ant. 1, 4)		
A	802.11ac (VHT80)		58	58	OFDM	BPSK	29.3			
A	802.11a		5500-5720	100 to 144	100, 116, 140, 144	OFDM	BPSK		6.0	Radio 1, CDD (Ant. 1, 2, 3, 4)
A	802.11ac (VHT20)			100 to 144	100, 116, 140, 144	OFDM	BPSK		6.5	
A	802.11ac (VHT40)	102 to 142		102, 110, 134, 142	OFDM	BPSK	13.5			
A	802.11ac (VHT80)	106 to 138		106, 122, 138	OFDM	BPSK	29.3			
A	802.11ac (VHT20)	100 to 144		100, 116, 140, 144	OFDM	BPSK	6.5	Radio 1, TxBF (Ant. 1, 2, 3, 4)		
A	802.11ac (VHT40)	102 to 142		102, 110, 134, 142	OFDM	BPSK	13.5			
A	802.11ac (VHT80)	106 to 138		106, 122, 138	OFDM	BPSK	29.3			
A	802.11a	100 to 144		100, 116, 140, 144	OFDM	BPSK	6.0			
A	802.11ac (VHT20)	100 to 144		100, 116, 140, 144	OFDM	BPSK	6.5	Radio 1, CDD (Ant. 2, 4)		
A	802.11ac (VHT40)	102 to 142		102, 110, 134, 142	OFDM	BPSK	13.5			
A	802.11ac (VHT80)	106 to 138		106, 122, 138	OFDM	BPSK	29.3			
A	802.11ac (VHT20)	100 to 144		100, 116, 140, 144	OFDM	BPSK	6.5			
A	802.11ac (VHT40)	102 to 142		102, 110, 134, 142	OFDM	BPSK	13.5	Radio 1, TxBF (Ant. 2, 4)		
A	802.11ac (VHT80)	106 to 138		106, 122, 138	OFDM	BPSK	29.3			

For Radio 2									
EUT CONFIGURE MODE	MODE	FREQ. BAND (MHz)	AVAILABLE CHANNEL	TESTED CHANNEL	MODULATION TECHNOLOGY	MODULATION TYPE	DATA RATE (Mbps)	MODE	
A	802.11a	5260-5320	52 to 64	52, 60, 64	OFDM	BPSK	6.0	Radio 2 with PIFA ant., CDD (Ant. 5, 6, 7, 8)	
A	802.11ac (VHT20)		52 to 64	52, 60, 64	OFDM	BPSK	6.5		
A	802.11ac (VHT40)		54 to 62	54, 62	OFDM	BPSK	13.5		
A	802.11ac (VHT80)		58	58	OFDM	BPSK	29.3		
A	802.11ac (VHT20)		52 to 64	52, 60, 64	OFDM	BPSK	6.5	Radio 2 with PIFA ant., TxBF (Ant. 5, 6, 7, 8)	
A	802.11ac (VHT40)		54 to 62	54, 62	OFDM	BPSK	13.5		
A	802.11ac (VHT80)		58	58	OFDM	BPSK	29.3		
A	802.11a		52 to 64	52, 60, 64	OFDM	BPSK	6.0	Radio 2 with PIFA ant., CDD (Ant. 7, 8)	
A	802.11ac (VHT20)		52 to 64	52, 60, 64	OFDM	BPSK	6.5		
A	802.11ac (VHT40)		54 to 62	54, 62	OFDM	BPSK	13.5		
A	802.11ac (VHT80)		58	58	OFDM	BPSK	29.3		
A	802.11ac (VHT20)		52 to 64	52, 60, 64	OFDM	BPSK	6.5	Radio 2 with PIFA ant., TxBF (Ant. 7, 8)	
A	802.11ac (VHT40)		54 to 62	54, 62	OFDM	BPSK	13.5		
A	802.11ac (VHT80)		58	58	OFDM	BPSK	29.3		
A	802.11a		5500-5720	100 to 144	100, 116, 140, 144	OFDM	BPSK	6.0	Radio 2 with PIFA ant., CDD (Ant. 5, 6, 7, 8)
A	802.11ac (VHT20)			100 to 144	100, 116, 140, 144	OFDM	BPSK	6.5	
A	802.11ac (VHT40)	102 to 142		102, 110, 134, 142	OFDM	BPSK	13.5		
A	802.11ac (VHT80)	106 to 138		106, 122, 138	OFDM	BPSK	29.3		
A	802.11ac (VHT20)	100 to 144		100, 116, 140, 144	OFDM	BPSK	6.5	Radio 2 with PIFA ant., TxBF (Ant. 5, 6, 7, 8)	
A	802.11ac (VHT40)	102 to 142		102, 110, 134, 142	OFDM	BPSK	13.5		
A	802.11ac (VHT80)	106 to 138		106, 122, 138	OFDM	BPSK	29.3		
A	802.11a	100 to 144		100, 116, 140, 144	OFDM	BPSK	6.0	Radio 2 with PIFA ant., CDD (Ant. 7, 8)	
A	802.11ac (VHT20)	100 to 144		100, 116, 140, 144	OFDM	BPSK	6.5		
A	802.11ac (VHT40)	102 to 142		102, 110, 134, 142	OFDM	BPSK	13.5		
A	802.11ac (VHT80)	106 to 138		106, 122, 138	OFDM	BPSK	29.3		
A	802.11ac (VHT20)	100 to 144		100, 116, 140, 144	OFDM	BPSK	6.5	Radio 2 with PIFA ant., TxBF (Ant. 7, 8)	
A	802.11ac (VHT40)	102 to 142		102, 110, 134, 142	OFDM	BPSK	13.5		
A	802.11ac (VHT80)	106 to 138		106, 122, 138	OFDM	BPSK	29.3		

Peak Power Spectral Density and Bandwidth Measurement:

- This item includes all test value of each mode, but only includes spectrum plot of worst value of each mode.
- Pre-Scan has been conducted to determine the worst-case mode from all possible combinations between available modulations, data rates and antenna ports (if EUT with antenna diversity architecture).
- Following channel(s) was (were) selected for the final test as listed below.

For Radio 1								
EUT CONFIGURE MODE	MODE	FREQ. BAND (MHz)	AVAILABLE CHANNEL	TESTED CHANNEL	MODULATION TECHNOLOGY	MODULATION TYPE	DATA RATE (Mbps)	MODE
A	802.11a	5260-5320	52 to 64	52, 60, 64	OFDM	BPSK	6.0	Radio 1, CDD (Ant. 1, 2, 3, 4)
A	802.11ac (VHT20)		52 to 64	52, 60, 64	OFDM	BPSK	6.5	
A	802.11ac (VHT40)		54 to 62	54, 62	OFDM	BPSK	13.5	
A	802.11ac (VHT80)		58	58	OFDM	BPSK	29.3	
A	802.11a		52 to 64	52, 60, 64	OFDM	BPSK	6.0	Radio 1, CDD (Ant. 1, 4)
A	802.11ac (VHT20)		52 to 64	52, 60, 64	OFDM	BPSK	6.5	
A	802.11ac (VHT40)		54 to 62	54, 62	OFDM	BPSK	13.5	
A	802.11ac (VHT80)		58	58	OFDM	BPSK	29.3	
A	802.11a	5500-5720	100 to 144	100, 116, 140, 144	OFDM	BPSK	6.0	Radio 1, CDD (Ant. 1, 2, 3, 4)
A	802.11ac (VHT20)		100 to 144	100, 116, 140, 144	OFDM	BPSK	6.5	
A	802.11ac (VHT40)		102 to 142	102, 110, 134, 142	OFDM	BPSK	13.5	
A	802.11ac (VHT80)		106 to 138	106, 122, 138	OFDM	BPSK	29.3	
A	802.11a		100 to 144	100, 116, 140, 144	OFDM	BPSK	6.0	Radio 1, CDD (Ant. 2, 4)
A	802.11ac (VHT20)		100 to 144	100, 116, 140, 144	OFDM	BPSK	6.5	
A	802.11ac (VHT40)		102 to 142	102, 110, 134, 142	OFDM	BPSK	13.5	
A	802.11ac (VHT80)		106 to 138	106, 122, 138	OFDM	BPSK	29.3	
For Radio 2								
EUT CONFIGURE MODE	MODE	FREQ. BAND (MHz)	AVAILABLE CHANNEL	TESTED CHANNEL	MODULATION TECHNOLOGY	MODULATION TYPE	DATA RATE (Mbps)	MODE
A	802.11a	5260-5320	52 to 64	52, 60, 64	OFDM	BPSK	6.0	Radio 2 with PIFA ant., CDD (Ant. 5, 6, 7, 8)
A	802.11ac (VHT20)		52 to 64	52, 60, 64	OFDM	BPSK	6.5	
A	802.11ac (VHT40)		54 to 62	54, 62	OFDM	BPSK	13.5	
A	802.11ac (VHT80)		58	58	OFDM	BPSK	29.3	
A	802.11a		52 to 64	52, 60, 64	OFDM	BPSK	6.0	Radio 2 with PIFA ant., CDD (Ant. 7, 8)
A	802.11ac (VHT20)		52 to 64	52, 60, 64	OFDM	BPSK	6.5	
A	802.11ac (VHT40)		54 to 62	54, 62	OFDM	BPSK	13.5	
A	802.11ac (VHT80)		58	58	OFDM	BPSK	29.3	
A	802.11a	5500-5720	100 to 144	100, 116, 140, 144	OFDM	BPSK	6.0	Radio 2 with PIFA ant., CDD (Ant. 5, 6, 7, 8)
A	802.11ac (VHT20)		100 to 144	100, 116, 140, 144	OFDM	BPSK	6.5	
A	802.11ac (VHT40)		102 to 142	102, 110, 134, 142	OFDM	BPSK	13.5	
A	802.11ac (VHT80)		106 to 138	106, 122, 138	OFDM	BPSK	29.3	
A	802.11a		100 to 144	100, 116, 140, 144	OFDM	BPSK	6.0	Radio 2 with PIFA ant., CDD (Ant. 7, 8)
A	802.11ac (VHT20)		100 to 144	100, 116, 140, 144	OFDM	BPSK	6.5	
A	802.11ac (VHT40)		102 to 142	102, 110, 134, 142	OFDM	BPSK	13.5	
A	802.11ac (VHT80)		106 to 138	106, 122, 138	OFDM	BPSK	29.3	

Frequency Stability:

- Pre-Scan has been conducted to determine the worst-case mode from all possible combinations between available modulations, data rates and antenna ports (if EUT with antenna diversity architecture).
- Following channel(s) was (were) selected for the final test as listed below.

For Radio 1								
EUT CONFIGURE MODE	MODE	FREQ. BAND (MHz)	AVAILABLE CHANNEL	TESTED CHANNEL	MODULATION TECHNOLOGY	MODULATION TYPE	DATA RATE (Mbps)	MODE
A	802.11a	5260-5320	54 to 62	52	OFDM	BPSK	29.3	Radio 1
	802.11a	5500-5720	100 to 144		OFDM	BPSK	29.3	
For Radio 2								
EUT CONFIGURE MODE	MODE	FREQ. BAND (MHz)	AVAILABLE CHANNEL	TESTED CHANNEL	MODULATION TECHNOLOGY	MODULATION TYPE	DATA RATE (Mbps)	MODE
A	802.11a	5260-5320	54 to 62	52	OFDM	BPSK	29.3	Radio 2
	802.11a	5500-5720	100 to 144		OFDM	BPSK	29.3	

Test Condition:

APPLICABLE TO	ENVIRONMENTAL CONDITIONS	INPUT POWER (SYSTEM)	TESTED BY
RE \geq 1G	21deg. C, 63%RH	120Vac, 60Hz	Tim Ho
	25deg. C, 65%RH	120Vac, 60Hz	Tim Ho
	25deg. C, 65%RH	120Vac, 60Hz	Robert Cheng
	22deg. C, 70%RH	120Vac, 60Hz	Gary Cheng
RE<1G	25deg. C, 65%RH	120Vac, 60Hz	Tim Ho
PLC	24deg. C, 61%RH	120Vac, 60Hz	JyunChun Lin
APCM	25deg. C, 60%RH	120Vac, 60Hz	Gary Cheng

3.3 Duty Cycle of Test Signal

802.11a, 802.11ac (VHT20), 802.11ac (VHT40): Duty cycle of test signal is > 98 %, duty factor is not required.

802.11ac (VHT80): Duty cycle of test signal is < 98 %, duty factor is required.

802.11a: Duty cycle = $2.061/2.082 = 0.990$

802.11ac (VHT20): Duty cycle = $1.927/1.963 = 0.982$

802.11ac (VHT40): Duty cycle = $0.951/0.970 = 0.980$

802.11ac (VHT80): Duty cycle = $0.460/0.479 = 0.960$, Duty factor = $10 * \log(1/0.960) = 0.18\text{dB}$

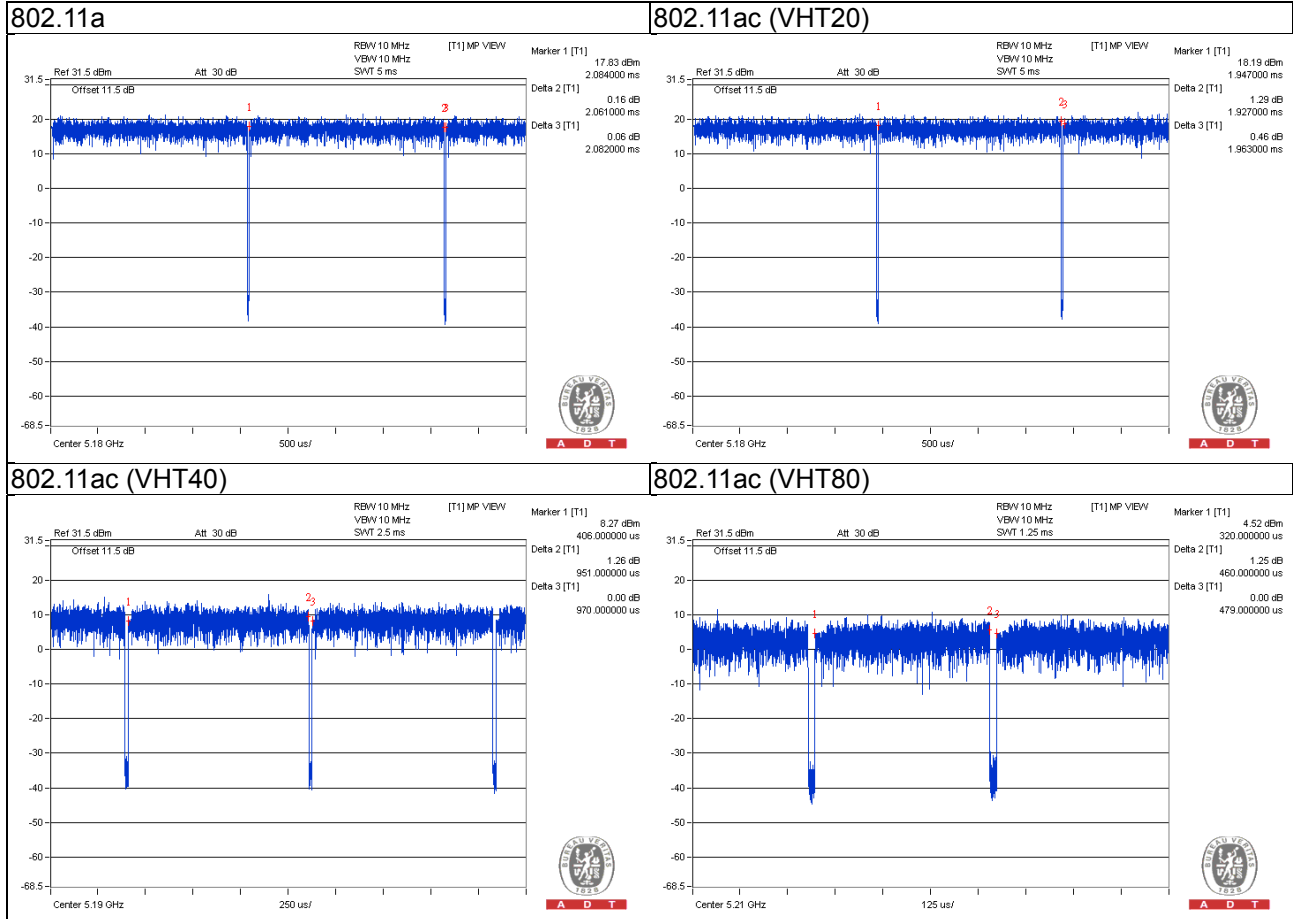

3.4 Description of Support Units

The EUT has been tested as an independent unit together with other necessary accessories or support units. The following support units or accessories were used to form a representative test configuration during the tests.

ID	Product	Brand	Model No.	Serial No.	FCC ID	Remarks
A.	Notebook	DELL	E5430	HYV4VY1	FCC DoC Approved	-
B.	iPod	Apple	MC749TA/A	CC4DMFJUDFDM	FCC DoC Approved	-
C.	HUB	ZyXEL	ES-116P	S060H02000215	FCC DoC Approved	-
D.	POE	PowerDsine	PD-9001GR/AT/AC	NA	NA	For test mode A
E.	Adapter	DVE	DSA-36PFH-12FUS	NA	NA	For test mode B

Note:

1. All power cords of the above support units are non-shielded (1.8m).
2. Items A and C acted as communication partners to transfer data.

ID	Descriptions	Qty.	Length (m)	Shielding (Yes/No)	Cores (Qty.)	Remarks
1.	USB cable	1	0.1	Y	0	-
2.	RJ45 cable	1	3	N	0	Cat5e For test mode A
3.	RJ45 cable	1	10	N	0	Cat5e
4.	RJ45 cable	1	10	N	0	Cat5e
5.	Console cable	1	1.5	N	0	-
6.	DC power cable	1	1.5	N	0	Attached on adapter For test mode B

3.4.1 Configuration of System under Test

Test Mode A

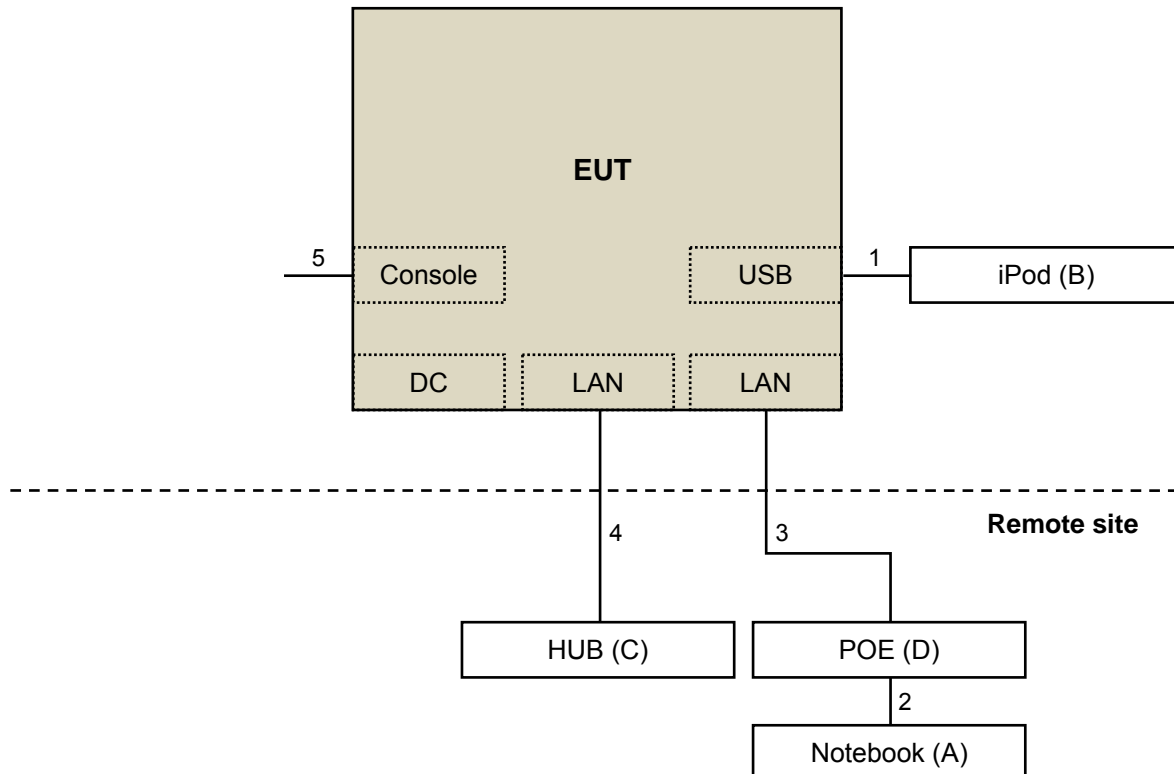

Test Mode B

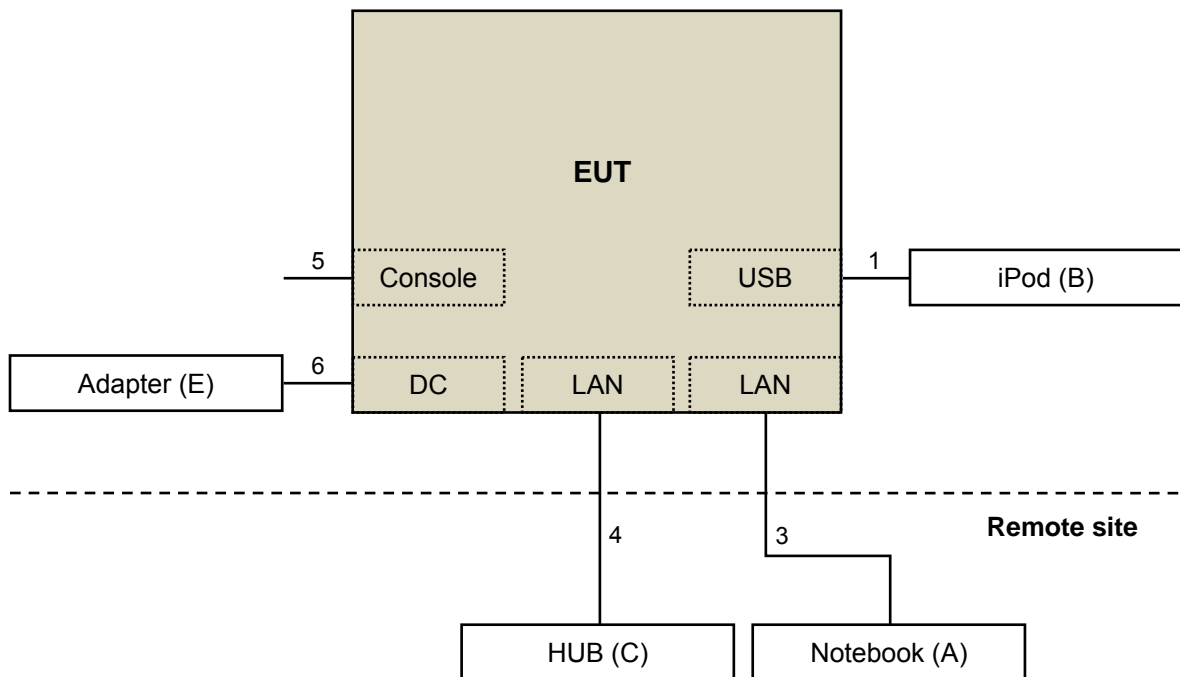

3.5 General Description of Applied Standards

The EUT is a RF Product. According to the specifications of the manufacturer, it must comply with the requirements of the following standards:

FCC Part 15, Subpart E (15.407)

KDB 789033 D02 General UNII Test Procedure New Rules v01r03

KDB 662911 D01 Multiple Transmitter Output v02r01

ANSI C63.10-2013

All test items have been performed and recorded as per the above standards.

4 Test Types and Results

4.1 Radiated Emission and Bandedge Measurement

4.1.1 Limits of Radiated Emission and Bandedge Measurement

Radiated emissions which fall in the restricted bands must comply with the radiated emission limits specified as below table.

Frequencies (MHz)	Field Strength (microvolts/meter)	Measurement Distance (meters)
0.009 ~ 0.490	2400/F(kHz)	300
0.490 ~ 1.705	24000/F(kHz)	30
1.705 ~ 30.0	30	30
30 ~ 88	100	3
88 ~ 216	150	3
216 ~ 960	200	3
Above 960	500	3

Note:

1. The lower limit shall apply at the transition frequencies.
2. Emission level (dBuV/m) = 20 log Emission level (uV/m).
3. For frequencies above 1000MHz, the field strength limits are based on average detector, however, the peak field strength of any emission shall not exceed the maximum permitted average limits, specified above by more than 20dB under any condition of modulation.

Limits of unwanted emission out of the restricted bands

Applicable To		Limit	
789033 D02 General UNII Test Procedure New Rules v01r03		Field Strength at 3m	
		PK:74 (dBµV/m)	AV:54 (dBµV/m)
Frequency Band	Applicable To	EIRP Limit	Equivalent Field Strength at 3m
5150~5250 MHz	15.407(b)(1)	PK:-27 (dBm/MHz)	PK:68.2(dBµV/m)
5250~5350 MHz	15.407(b)(2)		
5470~5725 MHz	15.407(b)(3)		
5725~5850 MHz	<input checked="" type="checkbox"/> 15.407(b)(4)(i)	PK:-27 (dBm/MHz) ^{*1} PK:10 (dBm/MHz) ^{*2} PK:15.6 (dBm/MHz) ^{*3} PK:27 (dBm/MHz) ^{*4}	PK: 68.2(dBµV/m) ^{*1} PK:105.2 (dBµV/m) ^{*2} PK: 110.8(dBµV/m) ^{*3} PK:122.2 (dBµV/m) ^{*4}
	<input type="checkbox"/> 15.407(b)(4)(ii)	Emission limits in section 15.247(d)	
^{*1} beyond 75 MHz or more above of the band edge.		^{*2} below the band edge increasing linearly to 10 dBm/MHz at 25 MHz above.	
^{*3} below the band edge increasing linearly to a level of 15.6 dBm/MHz at 5 MHz above.		^{*4} from 5 MHz above or below the band edge increasing linearly to a level of 27 dBm/MHz at the band edge.	

Note: The following formula is used to convert the equipment isotropic radiated power (eirp) to field strength:

$$E = \frac{1000000\sqrt{30P}}{3} \mu\text{V/m, where P is the eirp (Watts).$$

4.1.2 Test Instruments

Description & Manufacturer	Model No.	Serial No.	Cal. Date	Cal. Due
Test Receiver Agilent	N9038A	MY50010156	Aug. 12, 2015	Aug. 11, 2016
Pre-Amplifier(*) EMCI	EMC001340	980142	Jan. 20, 2016	Jan. 19, 2018
Loop Antenna(*) Electro-Metrics	EM-6879	264	Dec. 16, 2014	Dec. 15, 2016
RF Cable	NA	LOOPCAB-001 LOOPCAB-002	Jan. 18, 2016	Jan. 17, 2017
Pre-Amplifier Mini-Circuits	ZFL-1000VH2B	AMP-ZFL-05	May 07, 2016	May 06, 2017
Trilog Broadband Antenna SCHWARZBECK	VULB 9168	9168-156	Jan. 04, 2016	Jan. 03, 2017
RF Cable	8D	966-3-1 966-3-2 966-3-3	Apr. 02, 2016	Apr. 01, 2017
Horn_Antenna SCHWARZBECK	BBHA9120-D	9120D-406	Jan. 20, 2016	Jan. 19, 2017
Pre-Amplifier Agilent	8449B	3008A02465	Apr. 05, 2016	Apr. 04, 2017
RF Cable	EMC104-SM-SM-2000 EMC104-SM-SM-5000 EMC104-SM-SM-5000	150317 150321 150322	Mar. 30, 2016	Mar. 29, 2017
Spectrum Analyzer Keysight	N9030A	MY54490520	July 26, 2015	July 25, 2016
Pre-Amplifier EMCI	EMC184045	980143	Jan. 15, 2016	Jan. 14, 2017
Horn_Antenna SCHWARZBECK	BBHA 9170	BBHA9170608	Jan. 08, 2016	Jan. 07, 2017
RF Cable	SUCOFLEX 102	36432/2 36441/2	Jan. 16, 2016	Jan. 15, 2017
Software	ADT_Radiated_V8.7.0 7	NA	NA	NA
Antenna Tower & Turn Table Max-Full	MF-7802	MF780208406	NA	NA
Boresight Antenna Fixture	FBA-01	FBA-SIP01	NA	NA

Note:

1. The calibration interval of the above test instruments is 12 months and the calibrations are traceable to NML/ROC and NIST/USA.
2. The test was performed in 966 Chamber No. 3.
3. The FCC Site Registration No. is 147459
4. The CANADA Site Registration No. is 20331-1
5. Tested Date: May 07 ~ Jun. 22, 2016

Description & Manufacturer	Model No.	Serial No.	Cal. Date	Cal. Due
Spectrum Analyzer R&S	FSP40	100060	May 11, 2016	May 10, 2017
Spectrum Analyzer Agilent	E4446A	MY48250253	Dec. 22, 2015	Dec. 21, 2016
Power meter Anritsu	ML2495A	1014008	May 5, 2016	May 4, 2017
Power sensor Anritsu	MA2411B	0917122	May 5, 2016	May 4, 2017
AC Power Source Extech Electronics	6205	1440452	NA	NA
Temperature & Humidity Chamber Giant Force	GTH-150-40-SP-AR	MAA0812-008	Jan. 15, 2016	Jan. 14, 2017
DC Power Supply Topward	6603D	795558	NA	NA
ESG Vector signal generator Agilent	E4438C	MY45094468/005 506 602 UK6 UNJ	Dec. 01, 2015	Nov. 30, 2016
Mech Switch Absorptive Mini-Circuits	MSP4TA-18+	0140	Mar. 19, 2016	Mar. 18, 2017
FXD ATTEN Mini-Circuits	BW-S3W2+	MN71981	Mar. 19, 2016	Mar. 18, 2017
Software	ADT_RF Test Software V6.6.5.3	NA	NA	NA

Note:

1. The test was performed in Oven room 2.
2. The calibration interval of the above test instruments is 12 months and the calibrations are traceable to NML/ROC and NIST/USA.
3. Tested Date: Jun. 03 ~ Jun. 07, 2016

4.1.3 Test Procedures

- a. The EUT was placed on the top of a rotating table 0.8 meters (for below 1GHz) / 1.5 meters (for above 1GHz) above the ground at 3 meter chamber room for test. The table was rotated 360 degrees to determine the position of the highest radiation.
- b. The EUT was set 3 meters away from the interference-receiving antenna, which was mounted on the top of a variable-height antenna tower.
- c. The height of antenna is varied from one meter to four meters above the ground to determine the maximum value of the field strength. Both horizontal and vertical polarizations of the antenna are set to make the measurement.
- d. For each suspected emission, the EUT was arranged to its worst case and then the antenna was tuned to heights from 1 meter to 4 meters and the rotatable table was turned from 0 degrees to 360 degrees to find the maximum reading.
- e. The test-receiver system was set to quasi-peak detect function and specified bandwidth with maximum hold mode when the test frequency is below 1 GHz.
- f. The test-receiver system was set to peak and average detect function and specified bandwidth with maximum hold mode when the test frequency is above 1 GHz. If the peak reading value also meets average limit, measurement with the average detector is unnecessary.

Note:

1. The resolution bandwidth and video bandwidth of test receiver/spectrum analyzer is 120kHz for Quasi-peak detection (QP) at frequency below 1GHz.
2. The resolution bandwidth of test receiver/spectrum analyzer is 1 MHz and the video bandwidth is 3 MHz for Peak detection (PK) at frequency above 1GHz.
3. The resolution bandwidth of test receiver/spectrum analyzer is 1MHz and the video bandwidth is 3MHz for RMS Average (Duty cycle < 98%) for Average detection (AV) at frequency above 1GHz, then the measurement results was added to a correction factor ($10 \log(1/\text{duty cycle})$).
4. The resolution bandwidth of test receiver/spectrum analyzer is 1MHz and the video bandwidth is 10Hz (Duty cycle $\geq 98\%$) for Average detection (AV) at frequency above 1GHz.
5. All modes of operation were investigated and the worst-case emissions are reported.

4.1.4 Deviation from Test Standard

No deviation.

4.1.5 Test Set Up

<Frequency Range below 1GHz>

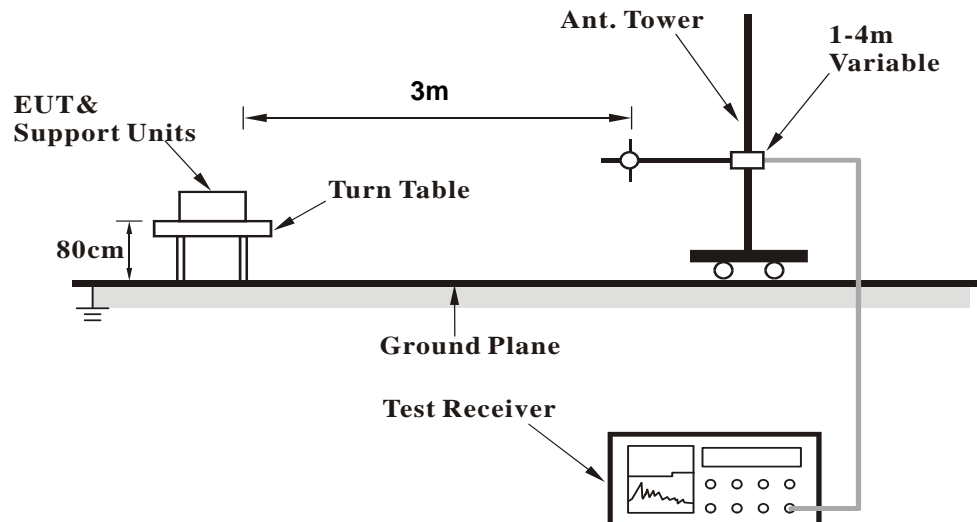

<Frequency Range above 1GHz>

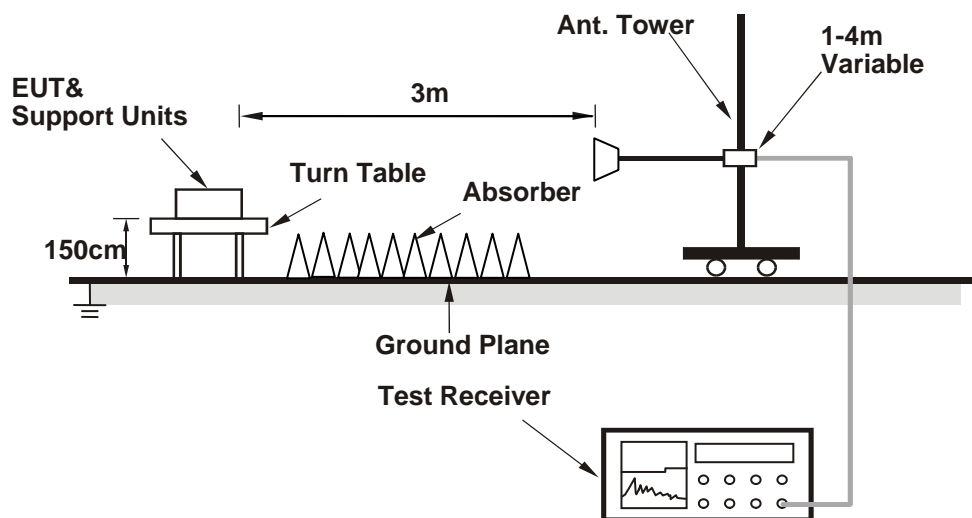

For the actual test configuration, please refer to the attached file (Test Setup Photo)

4.1.6 EUT Operating Conditions

- Placed the EUT on the testing table.
- Prepared notebook to act as communication partner and placed it outside of testing area.
- The communication partner connected with EUT via a RJ45 cable and ran a test program (MTool_REL_2_0_3_2) to enable EUT under transmission condition continuously at specific channel frequency.
- The communication partner sent data to EUT by command "PING".

4.1.7 Test Results

Above 1GHz Data

Radio 1 - 4TX CDD Mode

802.11a

CHANNEL	TX Channel 52	DETECTOR	Peak (PK)
FREQUENCY RANGE	1GHz ~ 40GHz	FUNCTION	Average (AV)

ANTENNA POLARITY & TEST DISTANCE: HORIZONTAL AT 3 M								
NO.	FREQ. (MHz)	EMISSION LEVEL (dBuV/m)	LIMIT (dBuV/m)	MARGIN (dB)	ANTENNA HEIGHT (m)	TABLE ANGLE (Degree)	RAW VALUE (dBuV)	CORRECTION FACTOR (dB/m)
1	5150.00	48.4 PK	74.0	-25.6	1.10 H	20	45.4	3.0
2	5150.00	37.1 AV	54.0	-16.9	1.10 H	20	34.1	3.0
3	*5260.00	95.2 PK			1.10 H	20	91.9	3.3
4	*5260.00	86.1 AV			1.10 H	20	82.8	3.3
5	#10520.00	50.7 PK	74.0	-23.3	1.00 H	69	36.6	14.1
6	#10520.00	40.9 AV	54.0	-13.1	1.00 H	69	26.8	14.1
7	15780.00	51.3 PK	74.0	-22.7	1.87 H	336	36.1	15.2
8	15780.00	40.1 AV	54.0	-13.9	1.87 H	336	24.9	15.2
ANTENNA POLARITY & TEST DISTANCE: VERTICAL AT 3 M								
NO.	FREQ. (MHz)	EMISSION LEVEL (dBuV/m)	LIMIT (dBuV/m)	MARGIN (dB)	ANTENNA HEIGHT (m)	TABLE ANGLE (Degree)	RAW VALUE (dBuV)	CORRECTION FACTOR (dB/m)
1	5150.00	48.0 PK	74.0	-26.0	2.37 V	259	45.0	3.0
2	5150.00	36.5 AV	54.0	-17.5	2.37 V	259	33.5	3.0
3	*5260.00	110.4 PK			2.37 V	259	107.1	3.3
4	*5260.00	101.2 AV			2.37 V	259	97.9	3.3
5	#10520.00	51.2 PK	74.0	-22.8	3.20 V	324	37.1	14.1
6	#10520.00	40.7 AV	54.0	-13.3	3.20 V	324	26.6	14.1
7	15780.00	50.8 PK	74.0	-23.2	3.78 V	202	35.6	15.2
8	15780.00	39.4 AV	54.0	-14.6	3.78 V	202	24.2	15.2

Remark:

1. Emission Level(dBuV/m) = Raw Value(dBuV) + Correction Factor(dB/m)
2. Correction Factor(dB/m) = Antenna Factor(dB/m) + Cable Factor(dB)
3. The other emission levels were very low against the limit.
4. Margin value = Emission Level – Limit value
5. " * ": Fundamental frequency.
6. " # ": The radiated frequency is out of the restricted band.

CHANNEL	TX Channel 60	DETECTOR FUNCTION	Peak (PK)
FREQUENCY RANGE	1GHz ~ 40GHz		Average (AV)

ANTENNA POLARITY & TEST DISTANCE: HORIZONTAL AT 3 M								
NO.	FREQ. (MHz)	EMISSION LEVEL (dBuV/m)	LIMIT (dBuV/m)	MARGIN (dB)	ANTENNA HEIGHT (m)	TABLE ANGLE (Degree)	RAW VALUE (dBuV)	CORRECTION FACTOR (dB/m)
1	*5300.00	95.2 PK			1.05 H	22	91.9	3.3
2	*5300.00	85.8 AV			1.05 H	22	82.5	3.3
3	10600.00	50.3 PK	74.0	-23.7	1.00 H	60	36.0	14.3
4	10600.00	40.5 AV	54.0	-13.5	1.00 H	60	26.2	14.3
5	15900.00	51.1 PK	74.0	-22.9	1.85 H	328	36.0	15.1
6	15900.00	40.0 AV	54.0	-14.0	1.85 H	328	24.9	15.1

ANTENNA POLARITY & TEST DISTANCE: VERTICAL AT 3 M								
NO.	FREQ. (MHz)	EMISSION LEVEL (dBuV/m)	LIMIT (dBuV/m)	MARGIN (dB)	ANTENNA HEIGHT (m)	TABLE ANGLE (Degree)	RAW VALUE (dBuV)	CORRECTION FACTOR (dB/m)
1	*5300.00	110.1 PK			2.24 V	257	106.8	3.3
2	*5300.00	101.0 AV			2.24 V	257	97.7	3.3
3	10600.00	51.1 PK	74.0	-22.9	3.16 V	323	36.8	14.3
4	10600.00	40.5 AV	54.0	-13.5	3.16 V	323	26.2	14.3
5	15900.00	51.4 PK	74.0	-22.6	3.84 V	223	36.3	15.1
6	15900.00	39.7 AV	54.0	-14.3	3.84 V	223	24.6	15.1

Remark:

1. Emission Level(dBuV/m) = Raw Value(dBuV) + Correction Factor(dB/m)
2. Correction Factor(dB/m) = Antenna Factor(dB/m) + Cable Factor(dB)
3. The other emission levels were very low against the limit.
4. Margin value = Emission Level – Limit value
5. " * ": Fundamental frequency.
6. " # ": The radiated frequency is out of the restricted band.

CHANNEL	TX Channel 64	DETECTOR FUNCTION	Peak (PK)
FREQUENCY RANGE	1GHz ~ 40GHz		Average (AV)

ANTENNA POLARITY & TEST DISTANCE: HORIZONTAL AT 3 M

NO.	FREQ. (MHz)	EMISSION LEVEL (dBuV/m)	LIMIT (dBuV/m)	MARGIN (dB)	ANTENNA HEIGHT (m)	TABLE ANGLE (Degree)	RAW VALUE (dBuV)	CORRECTION FACTOR (dB/m)
1	*5320.00	95.2 PK			1.12 H	5	91.7	3.5
2	*5320.00	86.2 AV			1.12 H	5	82.7	3.5
3	5350.00	48.1 PK	74.0	-25.9	1.12 H	5	44.6	3.5
4	5350.00	36.7 AV	54.0	-17.3	1.12 H	5	33.2	3.5
5	10640.00	50.8 PK	74.0	-23.2	1.00 H	63	36.5	14.3
6	10640.00	41.1 AV	54.0	-12.9	1.00 H	63	26.8	14.3
7	15960.00	51.3 PK	74.0	-22.7	1.93 H	338	36.2	15.1
8	15960.00	40.3 AV	54.0	-13.7	1.93 H	338	25.2	15.1

ANTENNA POLARITY & TEST DISTANCE: VERTICAL AT 3 M

NO.	FREQ. (MHz)	EMISSION LEVEL (dBuV/m)	LIMIT (dBuV/m)	MARGIN (dB)	ANTENNA HEIGHT (m)	TABLE ANGLE (Degree)	RAW VALUE (dBuV)	CORRECTION FACTOR (dB/m)
1	*5320.00	110.4 PK			2.76 V	220	106.9	3.5
2	*5320.00	101.2 AV			2.76 V	220	97.7	3.5
3	5350.00	68.4 PK	74.0	-5.6	2.76 V	220	64.9	3.5
4	5350.00	46.2 AV	54.0	-7.8	2.76 V	220	42.7	3.5
5	10640.00	50.4 PK	74.0	-23.6	3.14 V	339	36.1	14.3
6	10640.00	40.0 AV	54.0	-14.0	3.14 V	339	25.7	14.3
7	15960.00	50.7 PK	74.0	-23.3	3.76 V	213	35.6	15.1
8	15960.00	39.4 AV	54.0	-14.6	3.76 V	213	24.3	15.1

Remark:

1. Emission Level(dBuV/m) = Raw Value(dBuV) + Correction Factor(dB/m)
2. Correction Factor(dB/m) = Antenna Factor(dB/m) + Cable Factor(dB)
3. The other emission levels were very low against the limit.
4. Margin value = Emission Level – Limit value
5. " * ": Fundamental frequency.
6. " # ": The radiated frequency is out of the restricted band.

CHANNEL	TX Channel 100	DETECTOR FUNCTION	Peak (PK)
FREQUENCY RANGE	1GHz ~ 40GHz		Average (AV)

ANTENNA POLARITY & TEST DISTANCE: HORIZONTAL AT 3 M

NO.	FREQ. (MHz)	EMISSION LEVEL (dBuV/m)	LIMIT (dBuV/m)	MARGIN (dB)	ANTENNA HEIGHT (m)	TABLE ANGLE (Degree)	RAW VALUE (dBuV)	CORRECTION FACTOR (dB/m)
1	#5470.00	48.0 PK	74.0	-26.0	1.06 H	28	44.3	3.7
2	#5470.00	36.6 AV	54.0	-17.4	1.06 H	28	32.9	3.7
3	*5500.00	95.9 PK			1.06 H	28	92.1	3.8
4	*5500.00	86.6 AV			1.06 H	28	82.8	3.8
5	11000.00	50.9 PK	74.0	-23.1	1.04 H	61	35.7	15.2
6	11000.00	40.8 AV	54.0	-13.2	1.04 H	61	25.6	15.2
7	#16500.00	51.3 PK	74.0	-22.7	1.92 H	349	33.9	17.4
8	#16500.00	40.3 AV	54.0	-13.7	1.92 H	349	22.9	17.4

ANTENNA POLARITY & TEST DISTANCE: VERTICAL AT 3 M

NO.	FREQ. (MHz)	EMISSION LEVEL (dBuV/m)	LIMIT (dBuV/m)	MARGIN (dB)	ANTENNA HEIGHT (m)	TABLE ANGLE (Degree)	RAW VALUE (dBuV)	CORRECTION FACTOR (dB/m)
1	#5470.00	68.8 PK	74.0	-5.2	2.54 V	341	65.1	3.7
2	#5470.00	46.6 AV	54.0	-7.4	2.54 V	341	42.9	3.7
3	*5500.00	110.3 PK			2.69 V	38	106.5	3.8
4	*5500.00	101.2 AV			2.69 V	38	97.4	3.8
5	11000.00	51.4 PK	74.0	-22.6	3.13 V	345	36.2	15.2
6	11000.00	40.8 AV	54.0	-13.2	3.13 V	345	25.6	15.2
7	#16500.00	51.4 PK	74.0	-22.6	3.76 V	214	34.0	17.4
8	#16500.00	40.1 AV	54.0	-13.9	3.76 V	214	22.7	17.4

Remark:

1. Emission Level(dBuV/m) = Raw Value(dBuV) + Correction Factor(dB/m)
2. Correction Factor(dB/m) = Antenna Factor(dB/m) + Cable Factor(dB)
3. The other emission levels were very low against the limit.
4. Margin value = Emission Level – Limit value
5. " * ": Fundamental frequency.
6. " # ": The radiated frequency is out of the restricted band.

CHANNEL	TX Channel 116	DETECTOR FUNCTION	Peak (PK)
FREQUENCY RANGE	1GHz ~ 40GHz		Average (AV)

ANTENNA POLARITY & TEST DISTANCE: HORIZONTAL AT 3 M								
NO.	FREQ. (MHz)	EMISSION LEVEL (dBuV/m)	LIMIT (dBuV/m)	MARGIN (dB)	ANTENNA HEIGHT (m)	TABLE ANGLE (Degree)	RAW VALUE (dBuV)	CORRECTION FACTOR (dB/m)
1	*5580.00	95.0 PK			1.12 H	13	91.1	3.9
2	*5580.00	86.1 AV			1.12 H	13	82.2	3.9
3	11160.00	50.3 PK	74.0	-23.7	1.00 H	78	35.1	15.2
4	11160.00	40.5 AV	54.0	-13.5	1.00 H	78	25.3	15.2
5	#16740.00	51.3 PK	74.0	-22.7	1.88 H	348	33.0	18.3
6	#16740.00	39.8 AV	54.0	-14.2	1.88 H	348	21.5	18.3

ANTENNA POLARITY & TEST DISTANCE: VERTICAL AT 3 M								
NO.	FREQ. (MHz)	EMISSION LEVEL (dBuV/m)	LIMIT (dBuV/m)	MARGIN (dB)	ANTENNA HEIGHT (m)	TABLE ANGLE (Degree)	RAW VALUE (dBuV)	CORRECTION FACTOR (dB/m)
1	*5580.00	110.5 PK			2.44 V	35	106.6	3.9
2	*5580.00	101.5 AV			2.44 V	35	97.6	3.9
3	11160.00	50.6 PK	74.0	-23.4	3.16 V	335	35.4	15.2
4	11160.00	40.0 AV	54.0	-14.0	3.16 V	335	24.8	15.2
5	#16740.00	51.1 PK	74.0	-22.9	3.76 V	219	32.8	18.3
6	#16740.00	39.7 AV	54.0	-14.3	3.76 V	219	21.4	18.3

Remark:

1. Emission Level(dBuV/m) = Raw Value(dBuV) + Correction Factor(dB/m)
2. Correction Factor(dB/m) = Antenna Factor(dB/m) + Cable Factor(dB)
3. The other emission levels were very low against the limit.
4. Margin value = Emission Level – Limit value
5. " * ": Fundamental frequency.
6. " # ": The radiated frequency is out of the restricted band.

CHANNEL	TX Channel 140	DETECTOR FUNCTION	Peak (PK)
FREQUENCY RANGE	1GHz ~ 40GHz		Average (AV)

ANTENNA POLARITY & TEST DISTANCE: HORIZONTAL AT 3 M								
NO.	FREQ. (MHz)	EMISSION LEVEL (dBuV/m)	LIMIT (dBuV/m)	MARGIN (dB)	ANTENNA HEIGHT (m)	TABLE ANGLE (Degree)	RAW VALUE (dBuV)	CORRECTION FACTOR (dB/m)
1	*5700.00	95.5 PK			1.10 H	32	91.3	4.2
2	*5700.00	86.2 AV			1.10 H	32	82.0	4.2
3	#5725.00	48.3 PK	74.0	-25.7	1.10 H	32	44.1	4.2
4	#5725.00	36.9 AV	54.0	-17.1	1.10 H	32	32.7	4.2
5	11400.00	50.5 PK	74.0	-23.5	1.04 H	80	35.0	15.5
6	11400.00	40.6 AV	54.0	-13.4	1.04 H	80	25.1	15.5
7	#17100.00	51.2 PK	74.0	-22.8	1.87 H	340	31.1	20.1
8	#17100.00	39.8 AV	54.0	-14.2	1.87 H	340	19.7	20.1

ANTENNA POLARITY & TEST DISTANCE: VERTICAL AT 3 M								
NO.	FREQ. (MHz)	EMISSION LEVEL (dBuV/m)	LIMIT (dBuV/m)	MARGIN (dB)	ANTENNA HEIGHT (m)	TABLE ANGLE (Degree)	RAW VALUE (dBuV)	CORRECTION FACTOR (dB/m)
1	*5700.00	110.1 PK			2.53 V	38	105.9	4.2
2	*5700.00	101.0 AV			2.53 V	38	96.8	4.2
3	#5725.00	68.4 PK	74.0	-5.6	2.66 V	36	64.2	4.2
4	#5725.00	46.4 AV	54.0	-7.6	2.66 V	36	42.2	4.2
5	11400.00	49.9 PK	74.0	-24.1	3.12 V	351	34.4	15.5
6	11400.00	39.8 AV	54.0	-14.2	3.12 V	351	24.3	15.5
7	#17100.00	51.0 PK	74.0	-23.0	3.83 V	197	30.9	20.1
8	#17100.00	39.7 AV	54.0	-14.3	3.83 V	197	19.6	20.1

Remark:

1. Emission Level(dBuV/m) = Raw Value(dBuV) + Correction Factor(dB/m)
2. Correction Factor(dB/m) = Antenna Factor(dB/m) + Cable Factor(dB)
3. The other emission levels were very low against the limit.
4. Margin value = Emission Level – Limit value
5. " * ": Fundamental frequency.
6. " # ": The radiated frequency is out of the restricted band.

CHANNEL	TX Channel 144	DETECTOR FUNCTION	Peak (PK)
FREQUENCY RANGE	1GHz ~ 40GHz		Average (AV)

ANTENNA POLARITY & TEST DISTANCE: HORIZONTAL AT 3 M

NO.	FREQ. (MHz)	EMISSION LEVEL (dBuV/m)	LIMIT (dBuV/m)	MARGIN (dB)	ANTENNA HEIGHT (m)	TABLE ANGLE (Degree)	RAW VALUE (dBuV)	CORRECTION FACTOR (dB/m)
1	#5470.00	47.9 PK	74.0	-26.1	1.13 H	32	44.2	3.7
2	#5470.00	36.5 AV	54.0	-17.5	1.13 H	32	32.8	3.7
3	*5720.00	95.2 PK			1.13 H	32	91.0	4.2
4	*5720.00	86.0 AV			1.13 H	32	81.8	4.2
5	#5850.00	48.3 PK	74.0	-25.7	1.13 H	32	44.1	4.2
6	#5850.00	37.0 AV	54.0	-17.0	1.13 H	32	32.8	4.2
7	11440.00	50.4 PK	74.0	-23.6	1.07 H	71	35.1	15.3
8	11440.00	40.3 AV	54.0	-13.7	1.07 H	71	25.0	15.3
9	#17160.00	50.7 PK	74.0	-23.3	1.83 H	341	30.9	19.8
10	#17160.00	39.5 AV	54.0	-14.5	1.83 H	341	19.7	19.8

ANTENNA POLARITY & TEST DISTANCE: VERTICAL AT 3 M

NO.	FREQ. (MHz)	EMISSION LEVEL (dBuV/m)	LIMIT (dBuV/m)	MARGIN (dB)	ANTENNA HEIGHT (m)	TABLE ANGLE (Degree)	RAW VALUE (dBuV)	CORRECTION FACTOR (dB/m)
1	#5470.00	48.5 PK	74.0	-25.5	2.53 V	23	44.8	3.7
2	#5470.00	37.3 AV	54.0	-16.7	2.53 V	23	33.6	3.7
3	*5720.00	110.0 PK			2.53 V	23	105.8	4.2
4	*5720.00	100.8 AV			2.53 V	23	96.6	4.2
5	#5850.00	48.3 PK	74.0	-25.7	2.53 V	23	44.1	4.2
6	#5850.00	37.1 AV	54.0	-16.9	2.53 V	23	32.9	4.2
7	11440.00	49.5 PK	74.0	-24.5	3.15 V	345	34.2	15.3
8	11440.00	39.5 AV	54.0	-14.5	3.15 V	345	24.2	15.3
9	#17160.00	51.1 PK	74.0	-22.9	3.83 V	204	31.3	19.8
10	#17160.00	39.9 AV	54.0	-14.1	3.83 V	204	20.1	19.8

Remark:

1. Emission Level(dBuV/m) = Raw Value(dBuV) + Correction Factor(dB/m)
2. Correction Factor(dB/m) = Antenna Factor(dB/m) + Cable Factor(dB)
3. The other emission levels were very low against the limit.
4. Margin value = Emission Level – Limit value
5. " * ": Fundamental frequency.
6. " # ": The radiated frequency is out of the restricted band.

802.11ac (VHT20)

CHANNEL	TX Channel 52	DETECTOR FUNCTION	Peak (PK)
FREQUENCY RANGE	1GHz ~ 40GHz		Average (AV)

ANTENNA POLARITY & TEST DISTANCE: HORIZONTAL AT 3 M

NO.	FREQ. (MHz)	EMISSION LEVEL (dBuV/m)	LIMIT (dBuV/m)	MARGIN (dB)	ANTENNA HEIGHT (m)	TABLE ANGLE (Degree)	RAW VALUE (dBuV)	CORRECTION FACTOR (dB/m)
1	5150.00	48.3 PK	74.0	-25.7	1.11 H	5	45.3	3.0
2	5150.00	36.5 AV	54.0	-17.5	1.11 H	5	33.5	3.0
3	*5260.00	94.9 PK			1.11 H	5	91.6	3.3
4	*5260.00	85.7 AV			1.11 H	5	82.4	3.3
5	#10520.00	50.2 PK	74.0	-23.8	1.00 H	64	36.1	14.1
6	#10520.00	40.6 AV	54.0	-13.4	1.00 H	64	26.5	14.1
7	15780.00	51.3 PK	74.0	-22.7	1.85 H	336	36.1	15.2
8	15780.00	40.0 AV	54.0	-14.0	1.85 H	336	24.8	15.2

ANTENNA POLARITY & TEST DISTANCE: VERTICAL AT 3 M

NO.	FREQ. (MHz)	EMISSION LEVEL (dBuV/m)	LIMIT (dBuV/m)	MARGIN (dB)	ANTENNA HEIGHT (m)	TABLE ANGLE (Degree)	RAW VALUE (dBuV)	CORRECTION FACTOR (dB/m)
1	5150.00	48.2 PK	74.0	-25.8	2.70 V	130	45.2	3.0
2	5150.00	36.8 AV	54.0	-17.2	2.70 V	130	33.8	3.0
3	*5260.00	110.1 PK			2.70 V	130	106.8	3.3
4	*5260.00	101.1 AV			2.70 V	130	97.8	3.3
5	#10520.00	51.0 PK	74.0	-23.0	3.15 V	311	36.9	14.1
6	#10520.00	40.3 AV	54.0	-13.7	3.15 V	311	26.2	14.1
7	15780.00	51.0 PK	74.0	-23.0	3.76 V	199	35.8	15.2
8	15780.00	39.4 AV	54.0	-14.6	3.76 V	199	24.2	15.2

Remark:

1. Emission Level(dBuV/m) = Raw Value(dBuV) + Correction Factor(dB/m)
2. Correction Factor(dB/m) = Antenna Factor(dB/m) + Cable Factor(dB)
3. The other emission levels were very low against the limit.
4. Margin value = Emission Level – Limit value
5. " * ": Fundamental frequency.
6. " # ": The radiated frequency is out of the restricted band.

CHANNEL	TX Channel 60	DETECTOR FUNCTION	Peak (PK)
FREQUENCY RANGE	1GHz ~ 40GHz		Average (AV)

ANTENNA POLARITY & TEST DISTANCE: HORIZONTAL AT 3 M								
NO.	FREQ. (MHz)	EMISSION LEVEL (dBuV/m)	LIMIT (dBuV/m)	MARGIN (dB)	ANTENNA HEIGHT (m)	TABLE ANGLE (Degree)	RAW VALUE (dBuV)	CORRECTION FACTOR (dB/m)
1	*5300.00	95.0 PK			1.16 H	17	91.7	3.3
2	*5300.00	85.9 AV			1.16 H	17	82.6	3.3
3	10600.00	50.3 PK	74.0	-23.7	1.03 H	82	36.0	14.3
4	10600.00	40.7 AV	54.0	-13.3	1.03 H	82	26.4	14.3
5	15900.00	51.4 PK	74.0	-22.6	1.85 H	345	36.3	15.1
6	15900.00	40.3 AV	54.0	-13.7	1.85 H	345	25.2	15.1
ANTENNA POLARITY & TEST DISTANCE: VERTICAL AT 3 M								
NO.	FREQ. (MHz)	EMISSION LEVEL (dBuV/m)	LIMIT (dBuV/m)	MARGIN (dB)	ANTENNA HEIGHT (m)	TABLE ANGLE (Degree)	RAW VALUE (dBuV)	CORRECTION FACTOR (dB/m)
1	*5300.00	109.7 PK			2.62 V	38	106.4	3.3
2	*5300.00	100.8 AV			2.62 V	38	97.5	3.3
3	10600.00	50.9 PK	74.0	-23.1	3.07 V	326	36.6	14.3
4	10600.00	40.3 AV	54.0	-13.7	3.07 V	326	26.0	14.3
5	15900.00	50.2 PK	74.0	-23.8	3.79 V	223	35.1	15.1
6	15900.00	39.0 AV	54.0	-15.0	3.79 V	223	23.9	15.1

Remark:

1. Emission Level(dBuV/m) = Raw Value(dBuV) + Correction Factor(dB/m)
2. Correction Factor(dB/m) = Antenna Factor(dB/m) + Cable Factor(dB)
3. The other emission levels were very low against the limit.
4. Margin value = Emission Level – Limit value
5. " * ": Fundamental frequency.
6. " # ": The radiated frequency is out of the restricted band.

CHANNEL	TX Channel 64	DETECTOR FUNCTION	Peak (PK)
FREQUENCY RANGE	1GHz ~ 40GHz		Average (AV)

ANTENNA POLARITY & TEST DISTANCE: HORIZONTAL AT 3 M

NO.	FREQ. (MHz)	EMISSION LEVEL (dBuV/m)	LIMIT (dBuV/m)	MARGIN (dB)	ANTENNA HEIGHT (m)	TABLE ANGLE (Degree)	RAW VALUE (dBuV)	CORRECTION FACTOR (dB/m)
1	*5320.00	95.0 PK			1.10 H	23	91.5	3.5
2	*5320.00	85.8 AV			1.10 H	23	82.3	3.5
3	5350.00	48.5 PK	74.0	-25.5	1.10 H	23	45.0	3.5
4	5350.00	37.2 AV	54.0	-16.8	1.10 H	23	33.7	3.5
5	10640.00	50.1 PK	74.0	-23.9	1.04 H	82	35.8	14.3
6	10640.00	40.6 AV	54.0	-13.4	1.04 H	82	26.3	14.3
7	15960.00	51.1 PK	74.0	-22.9	1.92 H	344	36.0	15.1
8	15960.00	39.7 AV	54.0	-14.3	1.92 H	344	24.6	15.1

ANTENNA POLARITY & TEST DISTANCE: VERTICAL AT 3 M

NO.	FREQ. (MHz)	EMISSION LEVEL (dBuV/m)	LIMIT (dBuV/m)	MARGIN (dB)	ANTENNA HEIGHT (m)	TABLE ANGLE (Degree)	RAW VALUE (dBuV)	CORRECTION FACTOR (dB/m)
1	*5320.00	110.7 PK			2.61 V	33	107.2	3.5
2	*5320.00	101.7 AV			2.61 V	33	98.2	3.5
3	5350.00	68.3 PK	74.0	-5.7	2.46 V	33	64.8	3.5
4	5350.00	45.8 AV	54.0	-8.2	2.46 V	33	42.3	3.5
5	10640.00	50.8 PK	74.0	-23.2	3.07 V	320	36.5	14.3
6	10640.00	40.2 AV	54.0	-13.8	3.07 V	320	25.9	14.3
7	15960.00	50.8 PK	74.0	-23.2	3.74 V	201	35.7	15.1
8	15960.00	39.5 AV	54.0	-14.5	3.74 V	201	24.4	15.1

Remark:

1. Emission Level(dBuV/m) = Raw Value(dBuV) + Correction Factor(dB/m)
2. Correction Factor(dB/m) = Antenna Factor(dB/m) + Cable Factor(dB)
3. The other emission levels were very low against the limit.
4. Margin value = Emission Level – Limit value
5. " * ": Fundamental frequency.
6. " # ": The radiated frequency is out of the restricted band.

CHANNEL	TX Channel 100	DETECTOR FUNCTION	Peak (PK)
FREQUENCY RANGE	1GHz ~ 40GHz		Average (AV)

ANTENNA POLARITY & TEST DISTANCE: HORIZONTAL AT 3 M

NO.	FREQ. (MHz)	EMISSION LEVEL (dBuV/m)	LIMIT (dBuV/m)	MARGIN (dB)	ANTENNA HEIGHT (m)	TABLE ANGLE (Degree)	RAW VALUE (dBuV)	CORRECTION FACTOR (dB/m)
1	#5470.00	48.3 PK	74.0	-25.7	1.13 H	32	44.6	3.7
2	#5470.00	36.8 AV	54.0	-17.2	1.13 H	32	33.1	3.7
3	*5500.00	94.7 PK			1.13 H	32	90.9	3.8
4	*5500.00	85.8 AV			1.13 H	32	82.0	3.8
5	11000.00	50.4 PK	74.0	-23.6	1.04 H	67	35.2	15.2
6	11000.00	40.8 AV	54.0	-13.2	1.04 H	67	25.6	15.2
7	#16500.00	51.4 PK	74.0	-22.6	1.88 H	348	34.0	17.4
8	#16500.00	40.4 AV	54.0	-13.6	1.88 H	348	23.0	17.4

ANTENNA POLARITY & TEST DISTANCE: VERTICAL AT 3 M

NO.	FREQ. (MHz)	EMISSION LEVEL (dBuV/m)	LIMIT (dBuV/m)	MARGIN (dB)	ANTENNA HEIGHT (m)	TABLE ANGLE (Degree)	RAW VALUE (dBuV)	CORRECTION FACTOR (dB/m)
1	#5470.00	69.0 PK	74.0	-5.0	2.46 V	32	65.3	3.7
2	#5470.00	46.7 AV	54.0	-7.3	2.46 V	32	43.0	3.7
3	*5500.00	110.3 PK			2.46 V	32	106.5	3.8
4	*5500.00	101.3 AV			2.46 V	32	97.5	3.8
5	11000.00	50.1 PK	74.0	-23.9	3.10 V	329	34.9	15.2
6	11000.00	39.8 AV	54.0	-14.2	3.10 V	329	24.6	15.2
7	#16500.00	51.0 PK	74.0	-23.0	3.75 V	199	33.6	17.4
8	#16500.00	39.7 AV	54.0	-14.3	3.75 V	199	22.3	17.4

Remark:

1. Emission Level(dBuV/m) = Raw Value(dBuV) + Correction Factor(dB/m)
2. Correction Factor(dB/m) = Antenna Factor(dB/m) + Cable Factor(dB)
3. The other emission levels were very low against the limit.
4. Margin value = Emission Level – Limit value
5. " * ": Fundamental frequency.
6. " # ": The radiated frequency is out of the restricted band.

CHANNEL	TX Channel 116	DETECTOR FUNCTION	Peak (PK)
FREQUENCY RANGE	1GHz ~ 40GHz		Average (AV)

ANTENNA POLARITY & TEST DISTANCE: HORIZONTAL AT 3 M								
NO.	FREQ. (MHz)	EMISSION LEVEL (dBuV/m)	LIMIT (dBuV/m)	MARGIN (dB)	ANTENNA HEIGHT (m)	TABLE ANGLE (Degree)	RAW VALUE (dBuV)	CORRECTION FACTOR (dB/m)
1	*5580.00	95.1 PK			1.06 H	12	91.2	3.9
2	*5580.00	85.9 AV			1.06 H	12	82.0	3.9
3	11160.00	50.5 PK	74.0	-23.5	1.05 H	60	35.3	15.2
4	11160.00	40.7 AV	54.0	-13.3	1.05 H	60	25.5	15.2
5	#16740.00	52.0 PK	74.0	-22.0	1.86 H	324	33.7	18.3
6	#16740.00	40.5 AV	54.0	-13.5	1.86 H	324	22.2	18.3

ANTENNA POLARITY & TEST DISTANCE: VERTICAL AT 3 M								
NO.	FREQ. (MHz)	EMISSION LEVEL (dBuV/m)	LIMIT (dBuV/m)	MARGIN (dB)	ANTENNA HEIGHT (m)	TABLE ANGLE (Degree)	RAW VALUE (dBuV)	CORRECTION FACTOR (dB/m)
1	*5580.00	110.3 PK			2.47 V	32	106.4	3.9
2	*5580.00	101.1 AV			2.47 V	32	97.2	3.9
3	11160.00	50.2 PK	74.0	-23.8	3.11 V	314	35.0	15.2
4	11160.00	40.1 AV	54.0	-13.9	3.11 V	314	24.9	15.2
5	#16740.00	50.5 PK	74.0	-23.5	3.78 V	198	32.2	18.3
6	#16740.00	39.1 AV	54.0	-14.9	3.78 V	198	20.8	18.3

Remark:

1. Emission Level(dBuV/m) = Raw Value(dBuV) + Correction Factor(dB/m)
2. Correction Factor(dB/m) = Antenna Factor(dB/m) + Cable Factor(dB)
3. The other emission levels were very low against the limit.
4. Margin value = Emission Level – Limit value
5. " * ": Fundamental frequency.
6. " # ": The radiated frequency is out of the restricted band.

CHANNEL	TX Channel 140	DETECTOR FUNCTION	Peak (PK)
FREQUENCY RANGE	1GHz ~ 40GHz		Average (AV)

ANTENNA POLARITY & TEST DISTANCE: HORIZONTAL AT 3 M								
NO.	FREQ. (MHz)	EMISSION LEVEL (dBuV/m)	LIMIT (dBuV/m)	MARGIN (dB)	ANTENNA HEIGHT (m)	TABLE ANGLE (Degree)	RAW VALUE (dBuV)	CORRECTION FACTOR (dB/m)
1	*5700.00	95.1 PK			1.08 H	24	90.9	4.2
2	*5700.00	86.2 AV			1.08 H	24	82.0	4.2
3	#5725.00	48.0 PK	74.0	-26.0	1.08 H	24	43.8	4.2
4	#5725.00	36.7 AV	54.0	-17.3	1.08 H	24	32.5	4.2
5	11400.00	50.9 PK	74.0	-23.1	1.02 H	77	35.4	15.5
6	11400.00	40.9 AV	54.0	-13.1	1.02 H	77	25.4	15.5
7	#17100.00	51.4 PK	74.0	-22.6	1.89 H	323	31.3	20.1
8	#17100.00	40.1 AV	54.0	-13.9	1.89 H	323	20.0	20.1

ANTENNA POLARITY & TEST DISTANCE: VERTICAL AT 3 M								
NO.	FREQ. (MHz)	EMISSION LEVEL (dBuV/m)	LIMIT (dBuV/m)	MARGIN (dB)	ANTENNA HEIGHT (m)	TABLE ANGLE (Degree)	RAW VALUE (dBuV)	CORRECTION FACTOR (dB/m)
1	*5700.00	110.3 PK			2.85 V	32	106.1	4.2
2	*5700.00	101.2 AV			2.85 V	32	97.0	4.2
3	#5725.00	68.0 PK	74.0	-6.0	2.23 V	328	63.8	4.2
4	#5725.00	46.0 AV	54.0	-8.0	2.23 V	328	41.8	4.2
5	11400.00	50.7 PK	74.0	-23.3	3.11 V	336	35.2	15.5
6	11400.00	40.1 AV	54.0	-13.9	3.11 V	336	24.6	15.5
7	#17100.00	51.2 PK	74.0	-22.8	3.67 V	196	31.1	20.1
8	#17100.00	39.7 AV	54.0	-14.3	3.67 V	196	19.6	20.1

Remark:

1. Emission Level(dBuV/m) = Raw Value(dBuV) + Correction Factor(dB/m)
2. Correction Factor(dB/m) = Antenna Factor(dB/m) + Cable Factor(dB)
3. The other emission levels were very low against the limit.
4. Margin value = Emission Level – Limit value
5. " * ": Fundamental frequency.
6. " # ": The radiated frequency is out of the restricted band.

CHANNEL	TX Channel 144	DETECTOR FUNCTION	Peak (PK)
FREQUENCY RANGE	1GHz ~ 40GHz		Average (AV)

ANTENNA POLARITY & TEST DISTANCE: HORIZONTAL AT 3 M								
NO.	FREQ. (MHz)	EMISSION LEVEL (dBuV/m)	LIMIT (dBuV/m)	MARGIN (dB)	ANTENNA HEIGHT (m)	TABLE ANGLE (Degree)	RAW VALUE (dBuV)	CORRECTION FACTOR (dB/m)
1	#5470.00	48.3 PK	74.0	-25.7	1.01 H	6	44.6	3.7
2	#5470.00	37.1 AV	54.0	-16.9	1.01 H	6	33.4	3.7
3	*5720.00	94.8 PK			1.01 H	6	90.6	4.2
4	*5720.00	85.5 AV			1.01 H	6	81.3	4.2
5	#5850.00	48.6 PK	74.0	-25.4	1.01 H	6	44.4	4.2
6	#5850.00	37.2 AV	54.0	-16.8	1.01 H	6	33.0	4.2
7	11440.00	50.4 PK	74.0	-23.6	1.07 H	83	35.1	15.3
8	11440.00	40.5 AV	54.0	-13.5	1.07 H	83	25.2	15.3
9	#17160.00	51.2 PK	74.0	-22.8	1.85 H	322	31.4	19.8
10	#17160.00	39.8 AV	54.0	-14.2	1.85 H	322	20.0	19.8

ANTENNA POLARITY & TEST DISTANCE: VERTICAL AT 3 M								
NO.	FREQ. (MHz)	EMISSION LEVEL (dBuV/m)	LIMIT (dBuV/m)	MARGIN (dB)	ANTENNA HEIGHT (m)	TABLE ANGLE (Degree)	RAW VALUE (dBuV)	CORRECTION FACTOR (dB/m)
1	#5470.00	48.8 PK	74.0	-25.2	2.50 V	20	45.1	3.7
2	#5470.00	37.3 AV	54.0	-16.7	2.50 V	20	33.6	3.7
3	*5720.00	110.4 PK			2.50 V	20	106.2	4.2
4	*5720.00	101.4 AV			2.50 V	20	97.2	4.2
5	#5850.00	48.0 PK	74.0	-26.0	2.50 V	20	43.8	4.2
6	#5850.00	36.5 AV	54.0	-17.5	2.50 V	20	32.3	4.2
7	11440.00	50.6 PK	74.0	-23.4	3.13 V	334	35.3	15.3
8	11440.00	40.0 AV	54.0	-14.0	3.13 V	334	24.7	15.3
9	#17160.00	51.7 PK	74.0	-22.3	3.69 V	209	31.9	19.8
10	#17160.00	40.0 AV	54.0	-14.0	3.69 V	209	20.2	19.8

Remark:

1. Emission Level(dBuV/m) = Raw Value(dBuV) + Correction Factor(dB/m)
2. Correction Factor(dB/m) = Antenna Factor(dB/m) + Cable Factor(dB)
3. The other emission levels were very low against the limit.
4. Margin value = Emission Level – Limit value
5. " * ": Fundamental frequency.
6. " # ": The radiated frequency is out of the restricted band.

802.11ac (VHT40)

CHANNEL	TX Channel 54	DETECTOR FUNCTION	Peak (PK)
FREQUENCY RANGE	1GHz ~ 40GHz		Average (AV)

ANTENNA POLARITY & TEST DISTANCE: HORIZONTAL AT 3 M

NO.	FREQ. (MHz)	EMISSION LEVEL (dBuV/m)	LIMIT (dBuV/m)	MARGIN (dB)	ANTENNA HEIGHT (m)	TABLE ANGLE (Degree)	RAW VALUE (dBuV)	CORRECTION FACTOR (dB/m)
1	5150.00	48.7 PK	74.0	-25.3	1.15 H	27	45.7	3.0
2	5150.00	37.0 AV	54.0	-17.0	1.15 H	27	34.0	3.0
3	*5270.00	94.7 PK			1.15 H	27	91.4	3.3
4	*5270.00	85.6 AV			1.15 H	27	82.3	3.3
5	#10540.00	51.1 PK	74.0	-22.9	1.06 H	71	36.9	14.2
6	#10540.00	41.1 AV	54.0	-12.9	1.06 H	71	26.9	14.2
7	15810.00	50.5 PK	74.0	-23.5	1.83 H	343	35.5	15.0
8	15810.00	39.6 AV	54.0	-14.4	1.83 H	343	24.6	15.0

ANTENNA POLARITY & TEST DISTANCE: VERTICAL AT 3 M

NO.	FREQ. (MHz)	EMISSION LEVEL (dBuV/m)	LIMIT (dBuV/m)	MARGIN (dB)	ANTENNA HEIGHT (m)	TABLE ANGLE (Degree)	RAW VALUE (dBuV)	CORRECTION FACTOR (dB/m)
1	5150.00	50.8 PK	74.0	-23.2	2.61 V	41	47.8	3.0
2	5150.00	38.9 AV	54.0	-15.1	2.61 V	41	35.9	3.0
3	*5270.00	110.1 PK			2.61 V	41	106.8	3.3
4	*5270.00	100.3 AV			2.61 V	41	97.0	3.3
5	#10540.00	50.5 PK	74.0	-23.5	3.13 V	330	36.3	14.2
6	#10540.00	40.5 AV	54.0	-13.5	3.13 V	330	26.3	14.2
7	15810.00	50.9 PK	74.0	-23.1	3.82 V	236	35.9	15.0
8	15810.00	39.7 AV	54.0	-14.3	3.82 V	236	24.7	15.0

Remark:

1. Emission Level(dBuV/m) = Raw Value(dBuV) + Correction Factor(dB/m)
2. Correction Factor(dB/m) = Antenna Factor(dB/m) + Cable Factor(dB)
3. The other emission levels were very low against the limit.
4. Margin value = Emission Level – Limit value
5. " * ": Fundamental frequency.
6. " # ": The radiated frequency is out of the restricted band.

CHANNEL	TX Channel 62	DETECTOR FUNCTION	Peak (PK)
FREQUENCY RANGE	1GHz ~ 40GHz		Average (AV)

ANTENNA POLARITY & TEST DISTANCE: HORIZONTAL AT 3 M								
NO.	FREQ. (MHz)	EMISSION LEVEL (dBuV/m)	LIMIT (dBuV/m)	MARGIN (dB)	ANTENNA HEIGHT (m)	TABLE ANGLE (Degree)	RAW VALUE (dBuV)	CORRECTION FACTOR (dB/m)
1	*5310.00	93.6 PK			3.16 H	38	90.2	3.4
2	*5310.00	83.4 AV			3.16 H	38	80.0	3.4
3	5350.00	58.1 PK	74.0	-15.9	3.16 H	38	54.6	3.5
4	5350.00	46.1 AV	54.0	-7.9	3.16 H	38	42.6	3.5
5	10620.00	50.2 PK	74.0	-23.8	1.05 H	82	35.9	14.3
6	10620.00	40.4 AV	54.0	-13.6	1.05 H	82	26.1	14.3
7	15930.00	51.2 PK	74.0	-22.8	1.83 H	343	36.1	15.1
8	15930.00	39.9 AV	54.0	-14.1	1.83 H	343	24.8	15.1
ANTENNA POLARITY & TEST DISTANCE: VERTICAL AT 3 M								
NO.	FREQ. (MHz)	EMISSION LEVEL (dBuV/m)	LIMIT (dBuV/m)	MARGIN (dB)	ANTENNA HEIGHT (m)	TABLE ANGLE (Degree)	RAW VALUE (dBuV)	CORRECTION FACTOR (dB/m)
1	*5310.00	108.3 PK			2.80 V	41	104.9	3.4
2	*5310.00	98.3 AV			2.80 V	41	94.9	3.4
3	5350.00	66.5 PK	74.0	-7.5	2.43 V	39	63.0	3.5
4	5350.00	53.2 AV	54.0	-0.8	2.43 V	39	49.7	3.5
5	10620.00	50.1 PK	74.0	-23.9	3.14 V	342	35.8	14.3
6	10620.00	40.0 AV	54.0	-14.0	3.14 V	342	25.7	14.3
7	15930.00	51.4 PK	74.0	-22.6	3.79 V	225	36.3	15.1
8	15930.00	39.8 AV	54.0	-14.2	3.79 V	225	24.7	15.1

Remark:

1. Emission Level(dBuV/m) = Raw Value(dBuV) + Correction Factor(dB/m)
2. Correction Factor(dB/m) = Antenna Factor(dB/m) + Cable Factor(dB)
3. The other emission levels were very low against the limit.
4. Margin value = Emission Level – Limit value
5. " * ": Fundamental frequency.
6. " # ": The radiated frequency is out of the restricted band.

CHANNEL	TX Channel 102	DETECTOR FUNCTION	Peak (PK)
FREQUENCY RANGE	1GHz ~ 40GHz		Average (AV)

ANTENNA POLARITY & TEST DISTANCE: HORIZONTAL AT 3 M

NO.	FREQ. (MHz)	EMISSION LEVEL (dBuV/m)	LIMIT (dBuV/m)	MARGIN (dB)	ANTENNA HEIGHT (m)	TABLE ANGLE (Degree)	RAW VALUE (dBuV)	CORRECTION FACTOR (dB/m)
1	#5466.00	58.1 PK	74.0	-15.9	3.16 H	29	54.4	3.7
2	#5466.00	46.2 AV	54.0	-7.8	3.16 H	29	42.5	3.7
3	*5510.00	95.6 PK			3.16 H	29	91.8	3.8
4	*5510.00	85.2 AV			3.16 H	29	81.4	3.8
5	11020.00	50.1 PK	74.0	-23.9	1.00 H	67	35.0	15.1
6	11020.00	40.4 AV	54.0	-13.6	1.00 H	67	25.3	15.1
7	#16530.00	51.9 PK	74.0	-22.1	1.84 H	333	34.4	17.5
8	#16530.00	40.5 AV	54.0	-13.5	1.84 H	333	23.0	17.5

ANTENNA POLARITY & TEST DISTANCE: VERTICAL AT 3 M

NO.	FREQ. (MHz)	EMISSION LEVEL (dBuV/m)	LIMIT (dBuV/m)	MARGIN (dB)	ANTENNA HEIGHT (m)	TABLE ANGLE (Degree)	RAW VALUE (dBuV)	CORRECTION FACTOR (dB/m)
1	#5466.00	71.6 PK	74.0	-2.4	2.85 V	40	67.9	3.7
2	#5466.00	53.9 AV	54.0	-0.1	2.85 V	40	50.2	3.7
3	*5510.00	110.7 PK			2.79 V	39	106.9	3.8
4	*5510.00	100.7 AV			2.79 V	39	96.9	3.8
5	11020.00	50.8 PK	74.0	-23.2	3.10 V	326	35.7	15.1
6	11020.00	40.8 AV	54.0	-13.2	3.10 V	326	25.7	15.1
7	#16530.00	52.1 PK	74.0	-21.9	3.83 V	214	34.6	17.5
8	#16530.00	40.5 AV	54.0	-13.5	3.83 V	214	23.0	17.5

Remark:

1. Emission Level(dBuV/m) = Raw Value(dBuV) + Correction Factor(dB/m)
2. Correction Factor(dB/m) = Antenna Factor(dB/m) + Cable Factor(dB)
3. The other emission levels were very low against the limit.
4. Margin value = Emission Level – Limit value
5. " * ": Fundamental frequency.
6. " # ": The radiated frequency is out of the restricted band.

CHANNEL	TX Channel 110	DETECTOR FUNCTION	Peak (PK)
FREQUENCY RANGE	1GHz ~ 40GHz		Average (AV)

ANTENNA POLARITY & TEST DISTANCE: HORIZONTAL AT 3 M								
NO.	FREQ. (MHz)	EMISSION LEVEL (dBuV/m)	LIMIT (dBuV/m)	MARGIN (dB)	ANTENNA HEIGHT (m)	TABLE ANGLE (Degree)	RAW VALUE (dBuV)	CORRECTION FACTOR (dB/m)
1	5390.00	57.9 PK	74.0	-16.1	3.19 H	30	54.2	3.7
2	5390.00	46.1 AV	54.0	-7.9	3.19 H	30	42.4	3.7
3	*5550.00	97.7 PK			3.19 H	30	93.8	3.9
4	*5550.00	87.6 AV			3.19 H	30	83.7	3.9
5	11100.00	50.8 PK	74.0	-23.2	1.02 H	64	35.7	15.1
6	11100.00	41.2 AV	54.0	-12.8	1.02 H	64	26.1	15.1
7	#16650.00	51.1 PK	74.0	-22.9	1.86 H	325	33.1	18.0
8	#16650.00	39.6 AV	54.0	-14.4	1.86 H	325	21.6	18.0
ANTENNA POLARITY & TEST DISTANCE: VERTICAL AT 3 M								
NO.	FREQ. (MHz)	EMISSION LEVEL (dBuV/m)	LIMIT (dBuV/m)	MARGIN (dB)	ANTENNA HEIGHT (m)	TABLE ANGLE (Degree)	RAW VALUE (dBuV)	CORRECTION FACTOR (dB/m)
1	5390.00	63.8 PK	74.0	-10.2	2.32 V	40	60.1	3.7
2	5390.00	53.9 AV	54.0	-0.1	2.32 V	40	50.2	3.7
3	*5550.00	112.4 PK			3.01 V	38	108.5	3.9
4	*5550.00	102.3 AV			3.01 V	38	98.4	3.9
5	11100.00	50.7 PK	74.0	-23.3	3.10 V	325	35.6	15.1
6	11100.00	40.4 AV	54.0	-13.6	3.10 V	325	25.3	15.1
7	#16650.00	51.5 PK	74.0	-22.5	3.76 V	212	33.5	18.0
8	#16650.00	39.9 AV	54.0	-14.1	3.76 V	212	21.9	18.0

Remark:

1. Emission Level(dBuV/m) = Raw Value(dBuV) + Correction Factor(dB/m)
2. Correction Factor(dB/m) = Antenna Factor(dB/m) + Cable Factor(dB)
3. The other emission levels were very low against the limit.
4. Margin value = Emission Level – Limit value
5. " * ": Fundamental frequency.
6. " # ": The radiated frequency is out of the restricted band.

CHANNEL	TX Channel 134	DETECTOR FUNCTION	Peak (PK)
FREQUENCY RANGE	1GHz ~ 40GHz		Average (AV)

ANTENNA POLARITY & TEST DISTANCE: HORIZONTAL AT 3 M								
NO.	FREQ. (MHz)	EMISSION LEVEL (dBuV/m)	LIMIT (dBuV/m)	MARGIN (dB)	ANTENNA HEIGHT (m)	TABLE ANGLE (Degree)	RAW VALUE (dBuV)	CORRECTION FACTOR (dB/m)
1	*5670.00	97.2 PK			1.11 H	23	93.2	4.0
2	*5670.00	87.1 AV			1.11 H	23	83.1	4.0
3	#5725.00	58.0 PK	74.0	-16.0	1.11 H	23	53.8	4.2
4	#5725.00	45.9 AV	54.0	-8.1	1.11 H	23	41.7	4.2
5	11340.00	50.4 PK	74.0	-23.6	1.00 H	54	35.1	15.3
6	11340.00	40.5 AV	54.0	-13.5	1.00 H	54	25.2	15.3
7	#17010.00	51.2 PK	74.0	-22.8	1.90 H	338	31.3	19.9
8	#17010.00	40.1 AV	54.0	-13.9	1.90 H	338	20.2	19.9
ANTENNA POLARITY & TEST DISTANCE: VERTICAL AT 3 M								
NO.	FREQ. (MHz)	EMISSION LEVEL (dBuV/m)	LIMIT (dBuV/m)	MARGIN (dB)	ANTENNA HEIGHT (m)	TABLE ANGLE (Degree)	RAW VALUE (dBuV)	CORRECTION FACTOR (dB/m)
1	*5670.00	112.3 PK			2.36 V	40	108.3	4.0
2	*5670.00	102.1 AV			2.36 V	40	98.1	4.0
3	#5725.00	70.1 PK	74.0	-3.9	2.51 V	332	65.9	4.2
4	#5725.00	53.4 AV	54.0	-0.6	2.51 V	332	49.2	4.2
5	11340.00	50.8 PK	74.0	-23.2	3.17 V	330	35.5	15.3
6	11340.00	40.8 AV	54.0	-13.2	3.17 V	330	25.5	15.3
7	#17010.00	51.3 PK	74.0	-22.7	3.83 V	231	31.4	19.9
8	#17010.00	39.8 AV	54.0	-14.2	3.83 V	231	19.9	19.9

Remark:

1. Emission Level(dBuV/m) = Raw Value(dBuV) + Correction Factor(dB/m)
2. Correction Factor(dB/m) = Antenna Factor(dB/m) + Cable Factor(dB)
3. The other emission levels were very low against the limit.
4. Margin value = Emission Level – Limit value
5. " * ": Fundamental frequency.
6. " # ": The radiated frequency is out of the restricted band.

CHANNEL	TX Channel 142	DETECTOR FUNCTION	Peak (PK)
FREQUENCY RANGE	1GHz ~ 40GHz		Average (AV)

ANTENNA POLARITY & TEST DISTANCE: HORIZONTAL AT 3 M								
NO.	FREQ. (MHz)	EMISSION LEVEL (dBuV/m)	LIMIT (dBuV/m)	MARGIN (dB)	ANTENNA HEIGHT (m)	TABLE ANGLE (Degree)	RAW VALUE (dBuV)	CORRECTION FACTOR (dB/m)
1	#5470.00	58.5 PK	74.0	-15.5	1.05 H	24	54.8	3.7
2	#5470.00	46.6 AV	54.0	-7.4	1.05 H	24	42.9	3.7
3	*5710.00	96.7 PK			1.05 H	24	92.5	4.2
4	*5710.00	86.6 AV			1.05 H	24	82.4	4.2
5	#5850.00	58.3 PK	74.0	-15.7	1.05 H	24	54.1	4.2
6	#5850.00	46.2 AV	54.0	-7.8	1.05 H	24	42.0	4.2
7	11420.00	50.7 PK	74.0	-23.3	1.07 H	60	35.3	15.4
8	11420.00	40.9 AV	54.0	-13.1	1.07 H	60	25.5	15.4
9	#17130.00	51.1 PK	74.0	-22.9	1.89 H	331	31.1	20.0
10	#17130.00	39.8 AV	54.0	-14.2	1.89 H	331	19.8	20.0

ANTENNA POLARITY & TEST DISTANCE: VERTICAL AT 3 M								
NO.	FREQ. (MHz)	EMISSION LEVEL (dBuV/m)	LIMIT (dBuV/m)	MARGIN (dB)	ANTENNA HEIGHT (m)	TABLE ANGLE (Degree)	RAW VALUE (dBuV)	CORRECTION FACTOR (dB/m)
1	#5470.00	57.6 PK	74.0	-16.4	2.36 V	46	53.9	3.7
2	#5470.00	45.8 AV	54.0	-8.2	2.36 V	46	42.1	3.7
3	*5710.00	112.5 PK			2.36 V	46	108.3	4.2
4	*5710.00	102.5 AV			2.36 V	46	98.3	4.2
5	#5850.00	57.7 PK	74.0	-16.3	2.36 V	46	53.5	4.2
6	#5850.00	45.9 AV	54.0	-8.1	2.36 V	46	41.7	4.2
7	11420.00	51.0 PK	74.0	-23.0	3.19 V	319	35.6	15.4
8	11420.00	41.1 AV	54.0	-12.9	3.19 V	319	25.7	15.4
9	#17130.00	51.2 PK	74.0	-22.8	3.83 V	228	31.2	20.0
10	#17130.00	39.7 AV	54.0	-14.3	3.83 V	228	19.7	20.0

Remark:

1. Emission Level(dBuV/m) = Raw Value(dBuV) + Correction Factor(dB/m)
2. Correction Factor(dB/m) = Antenna Factor(dB/m) + Cable Factor(dB)
3. The other emission levels were very low against the limit.
4. Margin value = Emission Level – Limit value
5. " * " : Fundamental frequency.
6. " # " : The radiated frequency is out of the restricted band.

802.11ac (VHT80)

CHANNEL	TX Channel 58	DETECTOR FUNCTION	Peak (PK)
FREQUENCY RANGE	1GHz ~ 40GHz		Average (AV)

ANTENNA POLARITY & TEST DISTANCE: HORIZONTAL AT 3 M

NO.	FREQ. (MHz)	EMISSION LEVEL (dBuV/m)	LIMIT (dBuV/m)	MARGIN (dB)	ANTENNA HEIGHT (m)	TABLE ANGLE (Degree)	RAW VALUE (dBuV)	CORRECTION FACTOR (dB/m)
1	5150.00	50.0 PK	74.0	-24.0	3.13 H	35	47.0	3.0
2	5150.00	39.5 AV	54.0	-14.5	3.13 H	35	36.5	3.0
3	*5290.00	88.6 PK			3.13 H	35	85.3	3.3
4	*5290.00	79.6 AV			3.13 H	35	76.3	3.3
5	5350.00	57.5 PK	74.0	-16.5	3.13 H	35	54.0	3.5
6	5350.00	45.5 AV	54.0	-8.5	3.13 H	35	42.0	3.5
7	#10580.00	50.7 PK	74.0	-23.3	1.03 H	54	36.4	14.3
8	#10580.00	41.2 AV	54.0	-12.8	1.03 H	54	26.9	14.3
9	15870.00	51.6 PK	74.0	-22.4	1.82 H	343	36.6	15.0
10	15870.00	40.2 AV	54.0	-13.8	1.82 H	343	25.2	15.0

ANTENNA POLARITY & TEST DISTANCE: VERTICAL AT 3 M

NO.	FREQ. (MHz)	EMISSION LEVEL (dBuV/m)	LIMIT (dBuV/m)	MARGIN (dB)	ANTENNA HEIGHT (m)	TABLE ANGLE (Degree)	RAW VALUE (dBuV)	CORRECTION FACTOR (dB/m)
1	5150.00	50.0 PK	74.0	-24.0	2.53 V	37	47.0	3.0
2	5150.00	39.6 AV	54.0	-14.4	2.53 V	37	36.6	3.0
3	*5290.00	103.5 PK			2.53 V	37	100.2	3.3
4	*5290.00	94.8 AV			2.53 V	37	91.5	3.3
5	5350.00	66.5 PK	74.0	-7.5	2.53 V	27	63.0	3.5
6	5350.00	53.2 AV	54.0	-0.8	2.53 V	27	49.7	3.5
7	#10580.00	50.5 PK	74.0	-23.5	3.08 V	329	36.2	14.3
8	#10580.00	40.6 AV	54.0	-13.4	3.08 V	329	26.3	14.3
9	15870.00	50.9 PK	74.0	-23.1	3.73 V	221	35.9	15.0
10	15870.00	39.7 AV	54.0	-14.3	3.73 V	221	24.7	15.0

Remark:

1. Emission Level(dBuV/m) = Raw Value(dBuV) + Correction Factor(dB/m)
2. Correction Factor(dB/m) = Antenna Factor(dB/m) + Cable Factor(dB)
3. The other emission levels were very low against the limit.
4. Margin value = Emission Level – Limit value
5. " * ": Fundamental frequency.
6. " # ": The radiated frequency is out of the restricted band.

CHANNEL	TX Channel 106	DETECTOR FUNCTION	Peak (PK)
FREQUENCY RANGE	1GHz ~ 40GHz		Average (AV)

ANTENNA POLARITY & TEST DISTANCE: HORIZONTAL AT 3 M

NO.	FREQ. (MHz)	EMISSION LEVEL (dBuV/m)	LIMIT (dBuV/m)	MARGIN (dB)	ANTENNA HEIGHT (m)	TABLE ANGLE (Degree)	RAW VALUE (dBuV)	CORRECTION FACTOR (dB/m)
1	#5466.00	58.0 PK	74.0	-16.0	3.18 H	46	54.3	3.7
2	#5466.00	46.1 AV	54.0	-7.9	3.18 H	46	42.4	3.7
3	*5530.00	89.8 PK			3.18 H	46	85.9	3.9
4	*5530.00	80.2 AV			3.18 H	46	76.3	3.9
5	11060.00	50.4 PK	74.0	-23.6	1.00 H	73	35.3	15.1
6	11060.00	40.9 AV	54.0	-13.1	1.00 H	73	25.8	15.1
7	#16590.00	51.5 PK	74.0	-22.5	1.93 H	324	33.8	17.7
8	#16590.00	40.2 AV	54.0	-13.8	1.93 H	324	22.5	17.7

ANTENNA POLARITY & TEST DISTANCE: VERTICAL AT 3 M

NO.	FREQ. (MHz)	EMISSION LEVEL (dBuV/m)	LIMIT (dBuV/m)	MARGIN (dB)	ANTENNA HEIGHT (m)	TABLE ANGLE (Degree)	RAW VALUE (dBuV)	CORRECTION FACTOR (dB/m)
1	#5466.00	66.9 PK	74.0	-7.1	2.42 V	36	63.2	3.7
2	#5466.00	53.6 AV	54.0	-0.4	2.42 V	36	49.9	3.7
3	*5530.00	104.0 PK			2.81 V	33	100.1	3.9
4	*5530.00	95.2 AV			2.81 V	33	91.3	3.9
5	11060.00	50.8 PK	74.0	-23.2	3.11 V	335	35.7	15.1
6	11060.00	40.6 AV	54.0	-13.4	3.11 V	335	25.5	15.1
7	#16590.00	51.5 PK	74.0	-22.5	3.78 V	207	33.8	17.7
8	#16590.00	40.2 AV	54.0	-13.8	3.78 V	207	22.5	17.7

Remark:

1. Emission Level(dBuV/m) = Raw Value(dBuV) + Correction Factor(dB/m)
2. Correction Factor(dB/m) = Antenna Factor(dB/m) + Cable Factor(dB)
3. The other emission levels were very low against the limit.
4. Margin value = Emission Level – Limit value
5. " * ": Fundamental frequency.
6. " # ": The radiated frequency is out of the restricted band.

CHANNEL	TX Channel 122	DETECTOR FUNCTION	Peak (PK)
FREQUENCY RANGE	1GHz ~ 40GHz		Average (AV)

ANTENNA POLARITY & TEST DISTANCE: HORIZONTAL AT 3 M								
NO.	FREQ. (MHz)	EMISSION LEVEL (dBuV/m)	LIMIT (dBuV/m)	MARGIN (dB)	ANTENNA HEIGHT (m)	TABLE ANGLE (Degree)	RAW VALUE (dBuV)	CORRECTION FACTOR (dB/m)
1	*5610.00	92.9 PK			3.13 H	39	89.0	3.9
2	*5610.00	83.2 AV			3.13 H	39	79.3	3.9
3	#5725.00	57.4 PK	74.0	-16.6	3.13 H	39	53.2	4.2
4	#5725.00	45.3 AV	54.0	-8.7	3.13 H	39	41.1	4.2
5	11220.00	50.7 PK	74.0	-23.3	1.02 H	55	35.5	15.2
6	11220.00	41.0 AV	54.0	-13.0	1.02 H	55	25.8	15.2
7	#16830.00	51.7 PK	74.0	-22.3	1.82 H	348	33.2	18.5
8	#16830.00	40.3 AV	54.0	-13.7	1.82 H	348	21.8	18.5
ANTENNA POLARITY & TEST DISTANCE: VERTICAL AT 3 M								
NO.	FREQ. (MHz)	EMISSION LEVEL (dBuV/m)	LIMIT (dBuV/m)	MARGIN (dB)	ANTENNA HEIGHT (m)	TABLE ANGLE (Degree)	RAW VALUE (dBuV)	CORRECTION FACTOR (dB/m)
1	*5610.00	107.7 PK			3.04 V	34	103.8	3.9
2	*5610.00	98.0 AV			3.04 V	34	94.1	3.9
3	#5725.00	65.9 PK	74.0	-8.1	3.04 V	34	61.7	4.2
4	#5725.00	53.0 AV	54.0	-1.0	3.04 V	34	48.8	4.2
5	11220.00	50.7 PK	74.0	-23.3	3.17 V	337	35.5	15.2
6	11220.00	40.3 AV	54.0	-13.7	3.17 V	337	25.1	15.2
7	#16830.00	51.4 PK	74.0	-22.6	3.79 V	212	32.9	18.5
8	#16830.00	39.9 AV	54.0	-14.1	3.79 V	212	21.4	18.5

Remark:

1. Emission Level(dBuV/m) = Raw Value(dBuV) + Correction Factor(dB/m)
2. Correction Factor(dB/m) = Antenna Factor(dB/m) + Cable Factor(dB)
3. The other emission levels were very low against the limit.
4. Margin value = Emission Level – Limit value
5. " * ": Fundamental frequency.
6. " # ": The radiated frequency is out of the restricted band.

CHANNEL	TX Channel 138	DETECTOR FUNCTION	Peak (PK)
FREQUENCY RANGE	1GHz ~ 40GHz		Average (AV)

ANTENNA POLARITY & TEST DISTANCE: HORIZONTAL AT 3 M								
NO.	FREQ. (MHz)	EMISSION LEVEL (dBuV/m)	LIMIT (dBuV/m)	MARGIN (dB)	ANTENNA HEIGHT (m)	TABLE ANGLE (Degree)	RAW VALUE (dBuV)	CORRECTION FACTOR (dB/m)
1	#5470.00	57.7 PK	74.0	-16.3	3.11 H	30	54.0	3.7
2	#5470.00	45.2 AV	54.0	-8.8	3.11 H	30	41.5	3.7
3	*5690.00	93.2 PK			3.11 H	30	89.0	4.2
4	*5690.00	83.3 AV			3.11 H	30	79.1	4.2
5	#5850.00	57.5 PK	74.0	-16.5	3.11 H	30	53.3	4.2
6	#5850.00	45.4 AV	54.0	-8.6	3.11 H	30	41.2	4.2
7	11380.00	50.4 PK	74.0	-23.6	1.08 H	44	35.0	15.4
8	11380.00	40.9 AV	54.0	-13.1	1.08 H	44	25.5	15.4
9	#17070.00	51.3 PK	74.0	-22.7	1.77 H	334	31.3	20.0
10	#17070.00	39.8 AV	54.0	-14.2	1.77 H	334	19.8	20.0

ANTENNA POLARITY & TEST DISTANCE: VERTICAL AT 3 M								
NO.	FREQ. (MHz)	EMISSION LEVEL (dBuV/m)	LIMIT (dBuV/m)	MARGIN (dB)	ANTENNA HEIGHT (m)	TABLE ANGLE (Degree)	RAW VALUE (dBuV)	CORRECTION FACTOR (dB/m)
1	#5470.00	57.6 PK	74.0	-16.4	3.06 V	44	53.9	3.7
2	#5470.00	45.5 AV	54.0	-8.5	3.06 V	44	41.8	3.7
3	*5690.00	107.9 PK			3.06 V	44	103.7	4.2
4	*5690.00	98.0 AV			3.06 V	44	93.8	4.2
5	#5850.00	58.0 PK	74.0	-16.0	3.06 V	44	53.8	4.2
6	#5850.00	45.8 AV	54.0	-8.2	3.06 V	44	41.6	4.2
7	11380.00	50.4 PK	74.0	-23.6	3.14 V	340	35.0	15.4
8	11380.00	40.3 AV	54.0	-13.7	3.14 V	340	24.9	15.4
9	#17070.00	51.5 PK	74.0	-22.5	3.82 V	213	31.5	20.0
10	#17070.00	39.7 AV	54.0	-14.3	3.82 V	213	19.7	20.0

Remark:

1. Emission Level(dBuV/m) = Raw Value(dBuV) + Correction Factor(dB/m)
2. Correction Factor(dB/m) = Antenna Factor(dB/m) + Cable Factor(dB)
3. The other emission levels were very low against the limit.
4. Margin value = Emission Level – Limit value
5. " * ": Fundamental frequency.
6. " # ": The radiated frequency is out of the restricted band.

Radio 1 - 2TX CDD Mode

802.11a

CHANNEL	TX Channel 52	DETECTOR FUNCTION	Peak (PK)
FREQUENCY RANGE	1GHz ~ 40GHz		Average (AV)

ANTENNA POLARITY & TEST DISTANCE: HORIZONTAL AT 3 M

NO.	FREQ. (MHz)	EMISSION LEVEL (dBuV/m)	LIMIT (dBuV/m)	MARGIN (dB)	ANTENNA HEIGHT (m)	TABLE ANGLE (Degree)	RAW VALUE (dBuV)	CORRECTION FACTOR (dB/m)
1	5101.40	50.3 PK	74.0	-23.7	1.15 H	16	47.5	2.8
2	5101.40	39.5 AV	54.0	-14.5	1.15 H	16	36.7	2.8
3	*5260.00	109.3 PK			1.15 H	16	106.0	3.3
4	*5260.00	99.2 AV			1.15 H	16	95.9	3.3
5	5413.00	50.3 PK	74.0	-23.7	1.15 H	16	46.6	3.7
6	5413.00	39.9 AV	54.0	-14.1	1.15 H	16	36.2	3.7
7	#10520.00	59.4 PK	74.0	-14.6	3.86 H	325	45.3	14.1
8	#10520.00	47.3 AV	54.0	-6.7	3.86 H	325	33.2	14.1
9	15780.00	50.9 PK	74.0	-23.1	1.60 H	206	35.7	15.2
10	15780.00	39.8 AV	54.0	-14.2	1.60 H	206	24.6	15.2

ANTENNA POLARITY & TEST DISTANCE: VERTICAL AT 3 M

NO.	FREQ. (MHz)	EMISSION LEVEL (dBuV/m)	LIMIT (dBuV/m)	MARGIN (dB)	ANTENNA HEIGHT (m)	TABLE ANGLE (Degree)	RAW VALUE (dBuV)	CORRECTION FACTOR (dB/m)
1	5101.40	55.6 PK	74.0	-18.4	2.90 V	327	52.8	2.8
2	5101.40	45.7 AV	54.0	-8.3	2.90 V	327	42.9	2.8
3	*5260.00	116.9 PK			2.90 V	327	113.6	3.3
4	*5260.00	107.0 AV			2.90 V	327	103.7	3.3
5	5413.00	57.3 PK	74.0	-16.7	2.90 V	327	53.6	3.7
6	5413.00	44.1 AV	54.0	-9.9	2.90 V	327	40.4	3.7
7	#10520.00	60.9 PK	74.0	-13.1	3.05 V	302	46.8	14.1
8	#10520.00	50.1 AV	54.0	-3.9	3.05 V	302	36.0	14.1
9	15780.00	52.0 PK	74.0	-22.0	1.62 V	205	36.8	15.2
10	15780.00	41.1 AV	54.0	-12.9	1.62 V	205	25.9	15.2

Remark:

1. Emission Level(dBuV/m) = Raw Value(dBuV) + Correction Factor(dB/m)
2. Correction Factor(dB/m) = Antenna Factor(dB/m) + Cable Factor(dB)
3. The other emission levels were very low against the limit.
4. Margin value = Emission Level – Limit value
5. " * ": Fundamental frequency.
6. " # ": The radiated frequency is out of the restricted band.

CHANNEL	TX Channel 60	DETECTOR FUNCTION	Peak (PK)
FREQUENCY RANGE	1GHz ~ 40GHz		Average (AV)

ANTENNA POLARITY & TEST DISTANCE: HORIZONTAL AT 3 M								
NO.	FREQ. (MHz)	EMISSION LEVEL (dBuV/m)	LIMIT (dBuV/m)	MARGIN (dB)	ANTENNA HEIGHT (m)	TABLE ANGLE (Degree)	RAW VALUE (dBuV)	CORRECTION FACTOR (dB/m)
1	5150.00	56.7 PK	74.0	-17.3	2.26 H	32	53.7	3.0
2	5150.00	43.5 AV	54.0	-10.5	2.26 H	32	40.5	3.0
3	*5300.00	109.2 PK			2.26 H	32	105.9	3.3
4	*5300.00	99.0 AV			2.26 H	32	95.7	3.3
5	5350.00	50.6 PK	74.0	-23.4	2.26 H	32	47.1	3.5
6	5350.00	39.9 AV	54.0	-14.1	2.26 H	32	36.4	3.5
7	10600.00	60.0 PK	74.0	-14.0	3.90 H	315	45.7	14.3
8	10600.00	47.8 AV	54.0	-6.2	3.90 H	315	33.5	14.3
9	15900.00	51.2 PK	74.0	-22.8	1.64 H	221	36.1	15.1
10	15900.00	40.2 AV	54.0	-13.8	1.64 H	221	25.1	15.1

ANTENNA POLARITY & TEST DISTANCE: VERTICAL AT 3 M								
NO.	FREQ. (MHz)	EMISSION LEVEL (dBuV/m)	LIMIT (dBuV/m)	MARGIN (dB)	ANTENNA HEIGHT (m)	TABLE ANGLE (Degree)	RAW VALUE (dBuV)	CORRECTION FACTOR (dB/m)
1	5150.00	55.2 PK	74.0	-18.8	2.80 V	320	52.2	3.0
2	5150.00	45.4 AV	54.0	-8.6	2.80 V	320	42.4	3.0
3	*5300.00	117.4 PK			2.80 V	320	114.1	3.3
4	*5300.00	107.0 AV			2.80 V	320	103.7	3.3
5	5350.00	67.7 PK	74.0	-6.3	2.80 V	320	64.2	3.5
6	5350.00	50.4 AV	54.0	-3.6	2.80 V	320	46.9	3.5
7	10600.00	64.1 PK	74.0	-9.9	2.91 V	352	49.8	14.3
8	10600.00	51.8 AV	54.0	-2.2	2.91 V	352	37.5	14.3
9	15900.00	51.6 PK	74.0	-22.4	1.38 V	159	36.5	15.1
10	15900.00	40.5 AV	54.0	-13.5	1.38 V	159	25.4	15.1

Remark:

1. Emission Level(dBuV/m) = Raw Value(dBuV) + Correction Factor(dB/m)
2. Correction Factor(dB/m) = Antenna Factor(dB/m) + Cable Factor(dB)
3. The other emission levels were very low against the limit.
4. Margin value = Emission Level – Limit value
5. " * " : Fundamental frequency.
6. " # " : The radiated frequency is out of the restricted band.

CHANNEL	TX Channel 64	DETECTOR FUNCTION	Peak (PK)
FREQUENCY RANGE	1GHz ~ 40GHz		Average (AV)

ANTENNA POLARITY & TEST DISTANCE: HORIZONTAL AT 3 M								
NO.	FREQ. (MHz)	EMISSION LEVEL (dBuV/m)	LIMIT (dBuV/m)	MARGIN (dB)	ANTENNA HEIGHT (m)	TABLE ANGLE (Degree)	RAW VALUE (dBuV)	CORRECTION FACTOR (dB/m)
1	*5320.00	106.9 PK			1.22 H	16	103.4	3.5
2	*5320.00	96.9 AV			1.22 H	16	93.4	3.5
3	5350.00	65.9 PK	74.0	-8.1	1.22 H	16	62.4	3.5
4	5350.00	42.1 AV	54.0	-11.9	1.22 H	16	38.6	3.5
5	10640.00	59.6 PK	74.0	-14.4	3.89 H	312	45.3	14.3
6	10640.00	47.6 AV	54.0	-6.4	3.89 H	312	33.3	14.3
7	15960.00	51.1 PK	74.0	-22.9	1.62 H	228	36.0	15.1
8	15960.00	40.4 AV	54.0	-13.6	1.62 H	228	25.3	15.1

ANTENNA POLARITY & TEST DISTANCE: VERTICAL AT 3 M								
NO.	FREQ. (MHz)	EMISSION LEVEL (dBuV/m)	LIMIT (dBuV/m)	MARGIN (dB)	ANTENNA HEIGHT (m)	TABLE ANGLE (Degree)	RAW VALUE (dBuV)	CORRECTION FACTOR (dB/m)
1	*5320.00	114.7 PK			2.88 V	42	111.2	3.5
2	*5320.00	104.9 AV			2.88 V	42	101.4	3.5
3	5350.00	73.7 PK	74.0	-0.3	2.88 V	42	70.2	3.5
4	5350.00	49.7 AV	54.0	-4.3	2.88 V	42	46.2	3.5
5	10640.00	60.1 PK	74.0	-13.9	3.01 V	310	45.8	14.3
6	10640.00	49.6 AV	54.0	-4.4	3.01 V	310	35.3	14.3
7	15960.00	51.9 PK	74.0	-22.1	1.62 V	211	36.8	15.1
8	15960.00	41.4 AV	54.0	-12.6	1.62 V	211	26.3	15.1

Remark:

1. Emission Level(dBuV/m) = Raw Value(dBuV) + Correction Factor(dB/m)
2. Correction Factor(dB/m) = Antenna Factor(dB/m) + Cable Factor(dB)
3. The other emission levels were very low against the limit.
4. Margin value = Emission Level – Limit value
5. " * ": Fundamental frequency.
6. " # ": The radiated frequency is out of the restricted band.

CHANNEL	TX Channel 100	DETECTOR FUNCTION	Peak (PK)
FREQUENCY RANGE	1GHz ~ 40GHz		Average (AV)

ANTENNA POLARITY & TEST DISTANCE: HORIZONTAL AT 3 M								
NO.	FREQ. (MHz)	EMISSION LEVEL (dBuV/m)	LIMIT (dBuV/m)	MARGIN (dB)	ANTENNA HEIGHT (m)	TABLE ANGLE (Degree)	RAW VALUE (dBuV)	CORRECTION FACTOR (dB/m)
1	#5470.00	65.3 PK	74.0	-8.7	1.15 H	28	61.6	3.7
2	#5470.00	43.6 AV	54.0	-10.4	1.15 H	28	39.9	3.7
3	*5500.00	106.9 PK			1.15 H	28	103.1	3.8
4	*5500.00	97.4 AV			1.15 H	28	93.6	3.8
5	#5736.80	51.1 PK	74.0	-22.9	1.15 H	28	46.9	4.2
6	#5736.80	39.8 AV	54.0	-14.2	1.15 H	28	35.6	4.2
7	11000.00	51.0 PK	74.0	-23.0	1.67 H	240	35.8	15.2
8	11000.00	37.8 AV	54.0	-16.2	1.67 H	240	22.6	15.2
9	#16500.00	53.6 PK	74.0	-20.4	1.40 H	193	36.2	17.4
10	#16500.00	41.2 AV	54.0	-12.8	1.40 H	193	23.8	17.4

ANTENNA POLARITY & TEST DISTANCE: VERTICAL AT 3 M								
NO.	FREQ. (MHz)	EMISSION LEVEL (dBuV/m)	LIMIT (dBuV/m)	MARGIN (dB)	ANTENNA HEIGHT (m)	TABLE ANGLE (Degree)	RAW VALUE (dBuV)	CORRECTION FACTOR (dB/m)
1	#5470.00	73.4 PK	74.0	-0.6	2.82 V	46	69.7	3.7
2	#5470.00	51.9 AV	54.0	-2.1	2.82 V	46	48.2	3.7
3	*5500.00	115.4 PK			2.82 V	46	111.6	3.8
4	*5500.00	105.9 AV			2.82 V	46	102.1	3.8
5	#5736.80	59.3 PK	74.0	-14.7	2.65 V	43	55.1	4.2
6	#5736.80	47.9 AV	54.0	-6.1	2.65 V	43	43.7	4.2
7	11000.00	50.5 PK	74.0	-23.5	1.38 V	335	35.3	15.2
8	11000.00	39.7 AV	54.0	-14.3	1.38 V	335	24.5	15.2
9	#16500.00	54.2 PK	74.0	-19.8	1.52 V	236	36.8	17.4
10	#16500.00	42.0 AV	54.0	-12.0	1.52 V	236	24.6	17.4

Remark:

1. Emission Level(dBuV/m) = Raw Value(dBuV) + Correction Factor(dB/m)
2. Correction Factor(dB/m) = Antenna Factor(dB/m) + Cable Factor(dB)
3. The other emission levels were very low against the limit.
4. Margin value = Emission Level – Limit value
5. " * ": Fundamental frequency.
6. " # ": The radiated frequency is out of the restricted band.

CHANNEL	TX Channel 116	DETECTOR FUNCTION	Peak (PK)
FREQUENCY RANGE	1GHz ~ 40GHz		Average (AV)

ANTENNA POLARITY & TEST DISTANCE: HORIZONTAL AT 3 M								
NO.	FREQ. (MHz)	EMISSION LEVEL (dBuV/m)	LIMIT (dBuV/m)	MARGIN (dB)	ANTENNA HEIGHT (m)	TABLE ANGLE (Degree)	RAW VALUE (dBuV)	CORRECTION FACTOR (dB/m)
1	5414.10	56.3 PK	74.0	-17.7	2.35 H	270	52.6	3.7
2	5414.10	46.0 AV	54.0	-8.0	2.35 H	270	42.3	3.7
3	*5580.00	106.0 PK			2.35 H	272	102.1	3.9
4	*5580.00	97.2 AV			2.35 H	272	93.3	3.9
5	#5742.30	55.7 PK	74.0	-18.3	2.31 H	277	51.5	4.2
6	#5742.30	44.3 AV	54.0	-9.7	2.31 H	277	40.1	4.2
7	11160.00	51.1 PK	74.0	-22.9	1.64 H	231	35.9	15.2
8	11160.00	38.2 AV	54.0	-15.8	1.64 H	231	23.0	15.2
9	#16740.00	54.2 PK	74.0	-19.8	1.38 H	194	35.9	18.3
10	#16740.00	41.7 AV	54.0	-12.3	1.38 H	194	23.4	18.3

ANTENNA POLARITY & TEST DISTANCE: VERTICAL AT 3 M								
NO.	FREQ. (MHz)	EMISSION LEVEL (dBuV/m)	LIMIT (dBuV/m)	MARGIN (dB)	ANTENNA HEIGHT (m)	TABLE ANGLE (Degree)	RAW VALUE (dBuV)	CORRECTION FACTOR (dB/m)
1	5414.10	63.8 PK	74.0	-10.2	2.44 V	347	60.1	3.7
2	5414.10	53.9 AV	54.0	-0.1	2.44 V	347	50.2	3.7
3	*5580.00	115.6 PK			2.46 V	37	111.7	3.9
4	*5580.00	105.7 AV			2.46 V	37	101.8	3.9
5	#5742.30	61.6 PK	74.0	-12.4	2.63 V	40	57.4	4.2
6	#5742.30	51.4 AV	54.0	-2.6	2.63 V	40	47.2	4.2
7	11160.00	50.8 PK	74.0	-23.2	1.37 V	350	35.6	15.2
8	11160.00	40.0 AV	54.0	-14.0	1.37 V	350	24.8	15.2
9	#16740.00	54.2 PK	74.0	-19.8	1.46 V	231	35.9	18.3
10	#16740.00	41.9 AV	54.0	-12.1	1.46 V	231	23.6	18.3

Remark:

1. Emission Level(dBuV/m) = Raw Value(dBuV) + Correction Factor(dB/m)
2. Correction Factor(dB/m) = Antenna Factor(dB/m) + Cable Factor(dB)
3. The other emission levels were very low against the limit.
4. Margin value = Emission Level – Limit value
5. " * ": Fundamental frequency.
6. " # ": The radiated frequency is out of the restricted band.

CHANNEL	TX Channel 140	DETECTOR FUNCTION	Peak (PK)
FREQUENCY RANGE	1GHz ~ 40GHz		Average (AV)

ANTENNA POLARITY & TEST DISTANCE: HORIZONTAL AT 3 M

NO.	FREQ. (MHz)	EMISSION LEVEL (dBuV/m)	LIMIT (dBuV/m)	MARGIN (dB)	ANTENNA HEIGHT (m)	TABLE ANGLE (Degree)	RAW VALUE (dBuV)	CORRECTION FACTOR (dB/m)
1	*5700.00	104.5 PK			1.16 H	28	100.3	4.2
2	*5700.00	94.8 AV			1.16 H	28	90.6	4.2
3	#5725.00	65.4 PK	74.0	-8.6	1.16 H	28	61.2	4.2
4	#5725.00	45.5 AV	54.0	-8.5	1.16 H	28	41.3	4.2
5	#5863.70	51.5 PK	74.0	-22.5	1.16 H	28	47.3	4.2
6	#5863.70	42.4 AV	54.0	-11.6	1.16 H	28	38.2	4.2
7	11400.00	51.1 PK	74.0	-22.9	1.66 H	221	35.6	15.5
8	11400.00	38.2 AV	54.0	-15.8	1.66 H	221	22.7	15.5
9	#17100.00	54.6 PK	74.0	-19.4	1.33 H	182	34.5	20.1
10	#17100.00	42.1 AV	54.0	-11.9	1.33 H	182	22.0	20.1

ANTENNA POLARITY & TEST DISTANCE: VERTICAL AT 3 M

NO.	FREQ. (MHz)	EMISSION LEVEL (dBuV/m)	LIMIT (dBuV/m)	MARGIN (dB)	ANTENNA HEIGHT (m)	TABLE ANGLE (Degree)	RAW VALUE (dBuV)	CORRECTION FACTOR (dB/m)
1	*5700.00	111.8 PK			2.29 V	39	107.6	4.2
2	*5700.00	102.4 AV			2.29 V	39	98.2	4.2
3	#5725.00	73.8 PK	74.0	-0.2	2.29 V	39	69.6	4.2
4	#5725.00	53.7 AV	54.0	-0.3	2.29 V	39	49.5	4.2
5	#5863.70	60.1 PK	74.0	-13.9	2.29 V	281	55.9	4.2
6	#5863.70	50.9 AV	54.0	-3.1	2.29 V	281	46.7	4.2
7	11400.00	50.4 PK	74.0	-23.6	1.33 V	359	34.9	15.5
8	11400.00	39.7 AV	54.0	-14.3	1.33 V	359	24.2	15.5
9	#17100.00	54.4 PK	74.0	-19.6	1.45 V	233	34.3	20.1
10	#17100.00	42.0 AV	54.0	-12.0	1.45 V	233	21.9	20.1

Remark:

1. Emission Level(dBuV/m) = Raw Value(dBuV) + Correction Factor(dB/m)
2. Correction Factor(dB/m) = Antenna Factor(dB/m) + Cable Factor(dB)
3. The other emission levels were very low against the limit.
4. Margin value = Emission Level – Limit value
5. " * ": Fundamental frequency.
6. " # ": The radiated frequency is out of the restricted band.

CHANNEL	TX Channel 144	DETECTOR FUNCTION	Peak (PK)
FREQUENCY RANGE	1GHz ~ 40GHz		Average (AV)

ANTENNA POLARITY & TEST DISTANCE: HORIZONTAL AT 3 M								
NO.	FREQ. (MHz)	EMISSION LEVEL (dBuV/m)	LIMIT (dBuV/m)	MARGIN (dB)	ANTENNA HEIGHT (m)	TABLE ANGLE (Degree)	RAW VALUE (dBuV)	CORRECTION FACTOR (dB/m)
1	*5720.00	107.6 PK			1.23 H	20	103.4	4.2
2	*5720.00	98.0 AV			1.23 H	20	93.8	4.2
3	#5850.00	58.2 PK	68.2	-10.0	1.23 H	20	54.0	4.2
4	11440.00	51.6 PK	74.0	-22.4	1.68 H	241	36.3	15.3
5	11440.00	39.2 AV	54.0	-14.8	1.68 H	241	23.9	15.3
6	#17160.00	54.8 PK	68.2	-13.4	1.32 H	176	35.0	19.8
ANTENNA POLARITY & TEST DISTANCE: VERTICAL AT 3 M								
NO.	FREQ. (MHz)	EMISSION LEVEL (dBuV/m)	LIMIT (dBuV/m)	MARGIN (dB)	ANTENNA HEIGHT (m)	TABLE ANGLE (Degree)	RAW VALUE (dBuV)	CORRECTION FACTOR (dB/m)
1	*5720.00	115.7 PK			2.14 V	252	111.5	4.2
2	*5720.00	106.0 AV			2.14 V	252	101.8	4.2
3	#5850.00	66.1 PK	68.2	-2.1	2.33 V	35	61.9	4.2
4	11440.00	51.8 PK	74.0	-22.2	1.44 V	329	36.5	15.3
5	11440.00	40.7 AV	54.0	-13.3	1.44 V	329	25.4	15.3
6	#17160.00	56.7 PK	68.2	-11.5	1.39 V	233	36.9	19.8

Remark:

1. Emission Level(dBuV/m) = Raw Value(dBuV) + Correction Factor(dB/m)
2. Correction Factor(dB/m) = Antenna Factor(dB/m) + Cable Factor(dB)
3. The other emission levels were very low against the limit.
4. Margin value = Emission Level – Limit value
5. " * ": Fundamental frequency.
6. " # ": The radiated frequency is out of the restricted band.

802.11ac (VHT20)

CHANNEL	TX Channel 52	DETECTOR FUNCTION	Peak (PK)
FREQUENCY RANGE	1GHz ~ 40GHz		Average (AV)

ANTENNA POLARITY & TEST DISTANCE: HORIZONTAL AT 3 M

NO.	FREQ. (MHz)	EMISSION LEVEL (dBuV/m)	LIMIT (dBuV/m)	MARGIN (dB)	ANTENNA HEIGHT (m)	TABLE ANGLE (Degree)	RAW VALUE (dBuV)	CORRECTION FACTOR (dB/m)
1	5103.20	54.8 PK	74.0	-19.2	2.32 H	274	52.0	2.8
2	5103.20	43.5 AV	54.0	-10.5	2.32 H	274	40.7	2.8
3	*5260.00	109.7 PK			2.32 H	274	106.4	3.3
4	*5260.00	99.6 AV			2.32 H	274	96.3	3.3
5	#10520.00	50.9 PK	74.0	-23.1	1.54 H	219	36.8	14.1
6	#10520.00	38.8 AV	54.0	-15.2	1.54 H	219	24.7	14.1
7	15780.00	55.4 PK	74.0	-18.6	1.23 H	168	40.2	15.2
8	15780.00	42.6 AV	54.0	-11.4	1.23 H	168	27.4	15.2

ANTENNA POLARITY & TEST DISTANCE: VERTICAL AT 3 M

NO.	FREQ. (MHz)	EMISSION LEVEL (dBuV/m)	LIMIT (dBuV/m)	MARGIN (dB)	ANTENNA HEIGHT (m)	TABLE ANGLE (Degree)	RAW VALUE (dBuV)	CORRECTION FACTOR (dB/m)
1	5103.20	56.5 PK	74.0	-17.5	2.96 V	328	53.7	2.8
2	5103.20	45.2 AV	54.0	-8.8	2.96 V	328	42.4	2.8
3	*5260.00	117.3 PK			2.96 V	328	114.0	3.3
4	*5260.00	107.0 AV			2.96 V	328	103.7	3.3
5	#10520.00	51.8 PK	74.0	-22.2	1.37 V	341	37.7	14.1
6	#10520.00	40.8 AV	54.0	-13.2	1.37 V	341	26.7	14.1
7	15780.00	57.0 PK	74.0	-17.0	1.50 V	223	41.8	15.2
8	15780.00	44.5 AV	54.0	-9.5	1.50 V	223	29.3	15.2

Remark:

1. Emission Level(dBuV/m) = Raw Value(dBuV) + Correction Factor(dB/m)
2. Correction Factor(dB/m) = Antenna Factor(dB/m) + Cable Factor(dB)
3. The other emission levels were very low against the limit.
4. Margin value = Emission Level – Limit value
5. " * ": Fundamental frequency.
6. " # ": The radiated frequency is out of the restricted band.

CHANNEL	TX Channel 60	DETECTOR FUNCTION	Peak (PK)
FREQUENCY RANGE	1GHz ~ 40GHz		Average (AV)

ANTENNA POLARITY & TEST DISTANCE: HORIZONTAL AT 3 M

NO.	FREQ. (MHz)	EMISSION LEVEL (dBuV/m)	LIMIT (dBuV/m)	MARGIN (dB)	ANTENNA HEIGHT (m)	TABLE ANGLE (Degree)	RAW VALUE (dBuV)	CORRECTION FACTOR (dB/m)
1	*5300.00	109.7 PK			2.35 H	261	106.4	3.3
2	*5300.00	99.3 AV			2.35 H	261	96.0	3.3
3	5350.00	63.9 PK	74.0	-10.1	2.35 H	261	60.4	3.5
4	5350.00	43.6 AV	54.0	-10.4	2.35 H	261	40.1	3.5
5	10600.00	50.1 PK	74.0	-23.9	1.60 H	218	35.8	14.3
6	10600.00	38.5 AV	54.0	-15.5	1.60 H	218	24.2	14.3
7	15900.00	55.4 PK	74.0	-18.6	1.30 H	169	40.3	15.1
8	15900.00	42.5 AV	54.0	-11.5	1.30 H	169	27.4	15.1

ANTENNA POLARITY & TEST DISTANCE: VERTICAL AT 3 M

NO.	FREQ. (MHz)	EMISSION LEVEL (dBuV/m)	LIMIT (dBuV/m)	MARGIN (dB)	ANTENNA HEIGHT (m)	TABLE ANGLE (Degree)	RAW VALUE (dBuV)	CORRECTION FACTOR (dB/m)
1	*5300.00	117.1 PK			2.73 V	37	113.8	3.3
2	*5300.00	106.8 AV			2.73 V	37	103.5	3.3
3	5350.00	71.1 PK	74.0	-2.9	2.73 V	37	67.6	3.5
4	5350.00	50.8 AV	54.0	-3.2	2.73 V	37	47.3	3.5
5	10600.00	52.5 PK	74.0	-21.5	1.40 V	353	38.2	14.3
6	10600.00	41.0 AV	54.0	-13.0	1.40 V	353	26.7	14.3
7	15900.00	56.5 PK	74.0	-17.5	1.50 V	240	41.4	15.1
8	15900.00	43.9 AV	54.0	-10.1	1.50 V	240	28.8	15.1

Remark:

1. Emission Level(dBuV/m) = Raw Value(dBuV) + Correction Factor(dB/m)
2. Correction Factor(dB/m) = Antenna Factor(dB/m) + Cable Factor(dB)
3. The other emission levels were very low against the limit.
4. Margin value = Emission Level – Limit value
5. " * ": Fundamental frequency.
6. " # ": The radiated frequency is out of the restricted band.

CHANNEL	TX Channel 64	DETECTOR FUNCTION	Peak (PK)
FREQUENCY RANGE	1GHz ~ 40GHz		Average (AV)

ANTENNA POLARITY & TEST DISTANCE: HORIZONTAL AT 3 M

NO.	FREQ. (MHz)	EMISSION LEVEL (dBuV/m)	LIMIT (dBuV/m)	MARGIN (dB)	ANTENNA HEIGHT (m)	TABLE ANGLE (Degree)	RAW VALUE (dBuV)	CORRECTION FACTOR (dB/m)
1	*5320.00	107.5 PK			2.33 H	275	104.0	3.5
2	*5320.00	97.3 AV			2.33 H	275	93.8	3.5
3	5350.00	66.2 PK	74.0	-7.8	2.33 H	275	62.7	3.5
4	5350.00	43.4 AV	54.0	-10.6	2.33 H	275	39.9	3.5
5	10640.00	50.7 PK	74.0	-23.3	1.54 H	243	36.4	14.3
6	10640.00	38.5 AV	54.0	-15.5	1.54 H	243	24.2	14.3
7	15960.00	55.2 PK	74.0	-18.8	1.27 H	163	40.1	15.1
8	15960.00	42.6 AV	54.0	-11.4	1.27 H	163	27.5	15.1

ANTENNA POLARITY & TEST DISTANCE: VERTICAL AT 3 M

NO.	FREQ. (MHz)	EMISSION LEVEL (dBuV/m)	LIMIT (dBuV/m)	MARGIN (dB)	ANTENNA HEIGHT (m)	TABLE ANGLE (Degree)	RAW VALUE (dBuV)	CORRECTION FACTOR (dB/m)
1	*5320.00	114.4 PK			2.61 V	39	110.9	3.5
2	*5320.00	104.3 AV			2.61 V	39	100.8	3.5
3	5350.00	73.2 PK	74.0	-0.8	2.61 V	39	69.7	3.5
4	5350.00	50.4 AV	54.0	-3.6	2.61 V	39	46.9	3.5
5	10640.00	51.8 PK	74.0	-22.2	1.40 V	326	37.5	14.3
6	10640.00	40.5 AV	54.0	-13.5	1.40 V	326	26.2	14.3
7	15960.00	57.0 PK	74.0	-17.0	1.42 V	215	41.9	15.1
8	15960.00	44.3 AV	54.0	-9.7	1.42 V	215	29.2	15.1

Remark:

1. Emission Level(dBuV/m) = Raw Value(dBuV) + Correction Factor(dB/m)
2. Correction Factor(dB/m) = Antenna Factor(dB/m) + Cable Factor(dB)
3. The other emission levels were very low against the limit.
4. Margin value = Emission Level – Limit value
5. " * ": Fundamental frequency.
6. " # ": The radiated frequency is out of the restricted band.

CHANNEL	TX Channel 100	DETECTOR FUNCTION	Peak (PK)
FREQUENCY RANGE	1GHz ~ 40GHz		Average (AV)

ANTENNA POLARITY & TEST DISTANCE: HORIZONTAL AT 3 M

NO.	FREQ. (MHz)	EMISSION LEVEL (dBuV/m)	LIMIT (dBuV/m)	MARGIN (dB)	ANTENNA HEIGHT (m)	TABLE ANGLE (Degree)	RAW VALUE (dBuV)	CORRECTION FACTOR (dB/m)
1	#5470.00	67.1 PK	74.0	-6.9	2.36 H	268	63.4	3.7
2	#5470.00	45.0 AV	54.0	-9.0	2.36 H	268	41.3	3.7
3	*5500.00	106.3 PK			2.36 H	268	102.5	3.8
4	*5500.00	96.9 AV			2.36 H	268	93.1	3.8
5	#5737.10	51.9 PK	74.0	-22.1	2.36 H	268	47.7	4.2
6	#5737.10	41.9 AV	54.0	-12.1	2.36 H	268	37.7	4.2
7	11000.00	50.7 PK	74.0	-23.3	1.62 H	221	35.5	15.2
8	11000.00	39.1 AV	54.0	-14.9	1.62 H	221	23.9	15.2
9	#16500.00	54.9 PK	74.0	-19.1	1.31 H	157	37.5	17.4
10	#16500.00	42.3 AV	54.0	-11.7	1.31 H	157	24.9	17.4

ANTENNA POLARITY & TEST DISTANCE: VERTICAL AT 3 M

NO.	FREQ. (MHz)	EMISSION LEVEL (dBuV/m)	LIMIT (dBuV/m)	MARGIN (dB)	ANTENNA HEIGHT (m)	TABLE ANGLE (Degree)	RAW VALUE (dBuV)	CORRECTION FACTOR (dB/m)
1	#5470.00	73.8 PK	74.0	-0.2	2.76 V	231	70.1	3.7
2	#5470.00	51.8 AV	54.0	-2.2	2.76 V	231	48.1	3.7
3	*5500.00	113.7 PK			2.76 V	231	109.9	3.8
4	*5500.00	104.2 AV			2.76 V	231	100.4	3.8
5	#5737.10	59.1 PK	74.0	-14.9	2.76 V	40	54.9	4.2
6	#5737.10	49.2 AV	54.0	-4.8	2.76 V	40	45.0	4.2
7	11000.00	52.1 PK	74.0	-21.9	1.38 V	339	36.9	15.2
8	11000.00	41.0 AV	54.0	-13.0	1.38 V	339	25.8	15.2
9	#16500.00	57.0 PK	74.0	-17.0	1.51 V	232	39.6	17.4
10	#16500.00	44.6 AV	54.0	-9.4	1.51 V	232	27.2	17.4

Remark:

1. Emission Level(dBuV/m) = Raw Value(dBuV) + Correction Factor(dB/m)
2. Correction Factor(dB/m) = Antenna Factor(dB/m) + Cable Factor(dB)
3. The other emission levels were very low against the limit.
4. Margin value = Emission Level – Limit value
5. " * ": Fundamental frequency.
6. " # ": The radiated frequency is out of the restricted band.

CHANNEL	TX Channel 116	DETECTOR FUNCTION	Peak (PK)
FREQUENCY RANGE	1GHz ~ 40GHz		Average (AV)

ANTENNA POLARITY & TEST DISTANCE: HORIZONTAL AT 3 M

NO.	FREQ. (MHz)	EMISSION LEVEL (dBuV/m)	LIMIT (dBuV/m)	MARGIN (dB)	ANTENNA HEIGHT (m)	TABLE ANGLE (Degree)	RAW VALUE (dBuV)	CORRECTION FACTOR (dB/m)
1	5417.10	57.1 PK	74.0	-16.9	2.39 H	280	53.4	3.7
2	5417.10	47.1 AV	54.0	-6.9	2.39 H	280	43.4	3.7
3	*5580.00	107.4 PK			2.39 H	280	103.5	3.9
4	*5580.00	97.3 AV			2.39 H	280	93.4	3.9
5	11160.00	51.0 PK	74.0	-23.0	1.64 H	222	35.8	15.2
6	11160.00	38.9 AV	54.0	-15.1	1.64 H	222	23.7	15.2
7	#16740.00	55.1 PK	74.0	-18.9	1.28 H	162	36.8	18.3
8	#16740.00	42.7 AV	54.0	-11.3	1.28 H	162	24.4	18.3

ANTENNA POLARITY & TEST DISTANCE: VERTICAL AT 3 M

NO.	FREQ. (MHz)	EMISSION LEVEL (dBuV/m)	LIMIT (dBuV/m)	MARGIN (dB)	ANTENNA HEIGHT (m)	TABLE ANGLE (Degree)	RAW VALUE (dBuV)	CORRECTION FACTOR (dB/m)
1	5417.10	63.7 PK	74.0	-10.3	2.45 V	345	60.0	3.7
2	5417.10	53.8 AV	54.0	-0.2	2.45 V	345	50.1	3.7
3	*5580.00	114.6 PK			2.68 V	38	110.7	3.9
4	*5580.00	104.5 AV			2.68 V	38	100.6	3.9
5	11160.00	51.3 PK	74.0	-22.7	1.41 V	348	36.1	15.2
6	11160.00	40.3 AV	54.0	-13.7	1.41 V	348	25.1	15.2
7	#16740.00	56.6 PK	74.0	-17.4	1.48 V	232	38.3	18.3
8	#16740.00	44.0 AV	54.0	-10.0	1.48 V	232	25.7	18.3

Remark:

1. Emission Level(dBuV/m) = Raw Value(dBuV) + Correction Factor(dB/m)
2. Correction Factor(dB/m) = Antenna Factor(dB/m) + Cable Factor(dB)
3. The other emission levels were very low against the limit.
4. Margin value = Emission Level – Limit value
5. " * ": Fundamental frequency.
6. " # ": The radiated frequency is out of the restricted band.

CHANNEL	TX Channel 140	DETECTOR FUNCTION	Peak (PK)
FREQUENCY RANGE	1GHz ~ 40GHz		Average (AV)

ANTENNA POLARITY & TEST DISTANCE: HORIZONTAL AT 3 M								
NO.	FREQ. (MHz)	EMISSION LEVEL (dBuV/m)	LIMIT (dBuV/m)	MARGIN (dB)	ANTENNA HEIGHT (m)	TABLE ANGLE (Degree)	RAW VALUE (dBuV)	CORRECTION FACTOR (dB/m)
1	*5700.00	105.7 PK			2.37 H	258	101.5	4.2
2	*5700.00	94.3 AV			2.37 H	258	90.1	4.2
3	#5725.00	66.3 PK	74.0	-7.7	2.37 H	258	62.1	4.2
4	#5725.00	47.2 AV	54.0	-6.8	2.37 H	258	43.0	4.2
5	11400.00	50.8 PK	74.0	-23.2	1.54 H	248	35.3	15.5
6	11400.00	39.1 AV	54.0	-14.9	1.54 H	248	23.6	15.5
7	#17100.00	55.6 PK	74.0	-18.4	1.23 H	169	35.5	20.1
8	#17100.00	42.9 AV	54.0	-11.1	1.23 H	169	22.8	20.1
ANTENNA POLARITY & TEST DISTANCE: VERTICAL AT 3 M								
NO.	FREQ. (MHz)	EMISSION LEVEL (dBuV/m)	LIMIT (dBuV/m)	MARGIN (dB)	ANTENNA HEIGHT (m)	TABLE ANGLE (Degree)	RAW VALUE (dBuV)	CORRECTION FACTOR (dB/m)
1	*5700.00	113.0 PK			2.31 V	38	108.8	4.2
2	*5700.00	101.5 AV			2.31 V	38	97.3	4.2
3	#5725.00	72.5 PK	74.0	-1.5	2.31 V	38	68.3	4.2
4	#5725.00	53.7 AV	54.0	-0.3	2.31 V	38	49.5	4.2
5	11400.00	52.4 PK	74.0	-21.6	1.42 V	352	36.9	15.5
6	11400.00	40.9 AV	54.0	-13.1	1.42 V	352	25.4	15.5
7	#17100.00	56.0 PK	74.0	-18.0	1.43 V	235	35.9	20.1
8	#17100.00	43.7 AV	54.0	-10.3	1.43 V	235	23.6	20.1

Remark:

1. Emission Level(dBuV/m) = Raw Value(dBuV) + Correction Factor(dB/m)
2. Correction Factor(dB/m) = Antenna Factor(dB/m) + Cable Factor(dB)
3. The other emission levels were very low against the limit.
4. Margin value = Emission Level – Limit value
5. " * ": Fundamental frequency.
6. " # ": The radiated frequency is out of the restricted band.

CHANNEL	TX Channel 144	DETECTOR FUNCTION	Peak (PK)
FREQUENCY RANGE	1GHz ~ 40GHz		Average (AV)

ANTENNA POLARITY & TEST DISTANCE: HORIZONTAL AT 3 M								
NO.	FREQ. (MHz)	EMISSION LEVEL (dBuV/m)	LIMIT (dBuV/m)	MARGIN (dB)	ANTENNA HEIGHT (m)	TABLE ANGLE (Degree)	RAW VALUE (dBuV)	CORRECTION FACTOR (dB/m)
1	*5720.00	109.3 PK			2.29 H	263	105.1	4.2
2	*5720.00	98.9 AV			2.29 H	263	94.7	4.2
3	#5877.30	57.7 PK	74.0	-16.3	2.29 H	263	53.5	4.2
4	#5877.30	47.2 AV	54.0	-6.8	2.29 H	263	43.0	4.2
5	11440.00	50.6 PK	74.0	-23.4	1.62 H	219	35.3	15.3
6	11440.00	38.8 AV	54.0	-15.2	1.62 H	219	23.5	15.3
7	#17160.00	54.9 PK	74.0	-19.1	1.29 H	174	35.1	19.8
8	#17160.00	42.3 AV	54.0	-11.7	1.29 H	174	22.5	19.8

ANTENNA POLARITY & TEST DISTANCE: VERTICAL AT 3 M								
NO.	FREQ. (MHz)	EMISSION LEVEL (dBuV/m)	LIMIT (dBuV/m)	MARGIN (dB)	ANTENNA HEIGHT (m)	TABLE ANGLE (Degree)	RAW VALUE (dBuV)	CORRECTION FACTOR (dB/m)
1	*5720.00	116.2 PK			2.67 V	39	112.0	4.2
2	*5720.00	106.0 AV			2.67 V	39	101.8	4.2
3	#5877.30	64.4 PK	74.0	-9.6	2.66 V	333	60.2	4.2
4	#5877.30	53.8 AV	54.0	-0.2	2.66 V	333	49.6	4.2
5	11440.00	51.8 PK	74.0	-22.2	1.36 V	335	36.5	15.3
6	11440.00	40.6 AV	54.0	-13.4	1.36 V	335	25.3	15.3
7	#17160.00	57.2 PK	74.0	-16.8	1.44 V	235	37.4	19.8
8	#17160.00	44.6 AV	54.0	-9.4	1.44 V	235	24.8	19.8

Remark:

1. Emission Level(dBuV/m) = Raw Value(dBuV) + Correction Factor(dB/m)
2. Correction Factor(dB/m) = Antenna Factor(dB/m) + Cable Factor(dB)
3. The other emission levels were very low against the limit.
4. Margin value = Emission Level – Limit value
5. " * ": Fundamental frequency.
6. " # ": The radiated frequency is out of the restricted band.

802.11ac (VHT40)

CHANNEL	TX Channel 54	DETECTOR FUNCTION	Peak (PK)
FREQUENCY RANGE	1GHz ~ 40GHz		Average (AV)

ANTENNA POLARITY & TEST DISTANCE: HORIZONTAL AT 3 M

NO.	FREQ. (MHz)	EMISSION LEVEL (dBuV/m)	LIMIT (dBuV/m)	MARGIN (dB)	ANTENNA HEIGHT (m)	TABLE ANGLE (Degree)	RAW VALUE (dBuV)	CORRECTION FACTOR (dB/m)
1	*5270.00	105.9 PK			2.31 H	281	102.6	3.3
2	*5270.00	96.5 AV			2.31 H	281	93.2	3.3
3	5350.00	66.8 PK	74.0	-7.2	2.31 H	281	63.3	3.5
4	5350.00	46.9 AV	54.0	-7.1	2.31 H	281	43.4	3.5
5	#10540.00	50.9 PK	74.0	-23.1	1.56 H	239	36.7	14.2
6	#10540.00	38.7 AV	54.0	-15.3	1.56 H	239	24.5	14.2
7	15810.00	55.6 PK	74.0	-18.4	1.26 H	187	40.6	15.0
8	15810.00	42.6 AV	54.0	-11.4	1.26 H	187	27.6	15.0

ANTENNA POLARITY & TEST DISTANCE: VERTICAL AT 3 M

NO.	FREQ. (MHz)	EMISSION LEVEL (dBuV/m)	LIMIT (dBuV/m)	MARGIN (dB)	ANTENNA HEIGHT (m)	TABLE ANGLE (Degree)	RAW VALUE (dBuV)	CORRECTION FACTOR (dB/m)
1	*5270.00	113.4 PK			2.80 V	327	110.1	3.3
2	*5270.00	103.8 AV			2.80 V	327	100.5	3.3
3	5350.00	73.3 PK	74.0	-0.7	2.80 V	327	69.8	3.5
4	5350.00	53.7 AV	54.0	-0.3	2.80 V	327	50.2	3.5
5	#10540.00	51.7 PK	74.0	-22.3	1.35 V	350	37.5	14.2
6	#10540.00	40.8 AV	54.0	-13.2	1.35 V	350	26.6	14.2
7	15810.00	56.5 PK	74.0	-17.5	1.41 V	223	41.5	15.0
8	15810.00	43.7 AV	54.0	-10.3	1.41 V	223	28.7	15.0

Remark:

1. Emission Level(dBuV/m) = Raw Value(dBuV) + Correction Factor(dB/m)
2. Correction Factor(dB/m) = Antenna Factor(dB/m) + Cable Factor(dB)
3. The other emission levels were very low against the limit.
4. Margin value = Emission Level – Limit value
5. " * ": Fundamental frequency.
6. " # ": The radiated frequency is out of the restricted band.

CHANNEL	TX Channel 62	DETECTOR FUNCTION	Peak (PK)
FREQUENCY RANGE	1GHz ~ 40GHz		Average (AV)

ANTENNA POLARITY & TEST DISTANCE: HORIZONTAL AT 3 M								
NO.	FREQ. (MHz)	EMISSION LEVEL (dBuV/m)	LIMIT (dBuV/m)	MARGIN (dB)	ANTENNA HEIGHT (m)	TABLE ANGLE (Degree)	RAW VALUE (dBuV)	CORRECTION FACTOR (dB/m)
1	*5310.00	96.5 PK			2.37 H	270	93.1	3.4
2	*5310.00	87.9 AV			2.37 H	270	84.5	3.4
3	5350.00	60.5 PK	74.0	-13.5	2.37 H	270	57.0	3.5
4	5350.00	46.5 AV	54.0	-7.5	2.37 H	270	43.0	3.5
5	10620.00	50.6 PK	74.0	-23.4	1.61 H	237	36.3	14.3
6	10620.00	38.9 AV	54.0	-15.1	1.61 H	237	24.6	14.3
7	15930.00	55.7 PK	74.0	-18.3	1.32 H	163	40.6	15.1
8	15930.00	42.7 AV	54.0	-11.3	1.32 H	163	27.6	15.1
ANTENNA POLARITY & TEST DISTANCE: VERTICAL AT 3 M								
NO.	FREQ. (MHz)	EMISSION LEVEL (dBuV/m)	LIMIT (dBuV/m)	MARGIN (dB)	ANTENNA HEIGHT (m)	TABLE ANGLE (Degree)	RAW VALUE (dBuV)	CORRECTION FACTOR (dB/m)
1	*5310.00	104.2 PK			2.34 V	312	100.8	3.4
2	*5310.00	95.3 AV			2.34 V	312	91.9	3.4
3	5350.00	67.4 PK	74.0	-6.6	2.81 V	316	63.9	3.5
4	5350.00	53.2 AV	54.0	-0.8	2.81 V	316	49.7	3.5
5	10620.00	52.0 PK	74.0	-22.0	1.40 V	354	37.7	14.3
6	10620.00	40.7 AV	54.0	-13.3	1.40 V	354	26.4	14.3
7	15930.00	56.8 PK	74.0	-17.2	1.48 V	232	41.7	15.1
8	15930.00	44.1 AV	54.0	-9.9	1.48 V	232	29.0	15.1

Remark:

1. Emission Level(dBuV/m) = Raw Value(dBuV) + Correction Factor(dB/m)
2. Correction Factor(dB/m) = Antenna Factor(dB/m) + Cable Factor(dB)
3. The other emission levels were very low against the limit.
4. Margin value = Emission Level – Limit value
5. " * ": Fundamental frequency.
6. " # ": The radiated frequency is out of the restricted band.

CHANNEL	TX Channel 102	DETECTOR FUNCTION	Peak (PK)
FREQUENCY RANGE	1GHz ~ 40GHz		Average (AV)

ANTENNA POLARITY & TEST DISTANCE: HORIZONTAL AT 3 M

NO.	FREQ. (MHz)	EMISSION LEVEL (dBuV/m)	LIMIT (dBuV/m)	MARGIN (dB)	ANTENNA HEIGHT (m)	TABLE ANGLE (Degree)	RAW VALUE (dBuV)	CORRECTION FACTOR (dB/m)
1	#5470.00	60.6 PK	74.0	-13.4	2.35 H	286	56.9	3.7
2	#5470.00	46.7 AV	54.0	-7.3	2.35 H	286	43.0	3.7
3	*5510.00	99.8 PK			2.35 H	286	96.0	3.8
4	*5510.00	90.6 AV			2.35 H	286	86.8	3.8
5	11020.00	50.5 PK	74.0	-23.5	1.56 H	235	35.4	15.1
6	11020.00	38.9 AV	54.0	-15.1	1.56 H	235	23.8	15.1
7	#16530.00	55.1 PK	74.0	-18.9	1.28 H	184	37.6	17.5
8	#16530.00	42.2 AV	54.0	-11.8	1.28 H	184	24.7	17.5

ANTENNA POLARITY & TEST DISTANCE: VERTICAL AT 3 M

NO.	FREQ. (MHz)	EMISSION LEVEL (dBuV/m)	LIMIT (dBuV/m)	MARGIN (dB)	ANTENNA HEIGHT (m)	TABLE ANGLE (Degree)	RAW VALUE (dBuV)	CORRECTION FACTOR (dB/m)
1	#5470.00	67.6 PK	74.0	-6.4	2.58 V	35	63.9	3.7
2	#5470.00	53.7 AV	54.0	-0.3	2.58 V	35	50.0	3.7
3	*5510.00	107.3 PK			2.57 V	35	103.5	3.8
4	*5510.00	98.0 AV			2.57 V	35	94.2	3.8
5	11020.00	52.0 PK	74.0	-22.0	1.33 V	348	36.9	15.1
6	11020.00	40.6 AV	54.0	-13.4	1.33 V	348	25.5	15.1
7	#16530.00	56.8 PK	74.0	-17.2	1.47 V	221	39.3	17.5
8	#16530.00	44.4 AV	54.0	-9.6	1.47 V	221	26.9	17.5

Remark:

1. Emission Level(dBuV/m) = Raw Value(dBuV) + Correction Factor(dB/m)
2. Correction Factor(dB/m) = Antenna Factor(dB/m) + Cable Factor(dB)
3. The other emission levels were very low against the limit.
4. Margin value = Emission Level – Limit value
5. " * ": Fundamental frequency.
6. " # ": The radiated frequency is out of the restricted band.

CHANNEL	TX Channel 110	DETECTOR FUNCTION	Peak (PK)
FREQUENCY RANGE	1GHz ~ 40GHz		Average (AV)

ANTENNA POLARITY & TEST DISTANCE: HORIZONTAL AT 3 M

NO.	FREQ. (MHz)	EMISSION LEVEL (dBuV/m)	LIMIT (dBuV/m)	MARGIN (dB)	ANTENNA HEIGHT (m)	TABLE ANGLE (Degree)	RAW VALUE (dBuV)	CORRECTION FACTOR (dB/m)
1	#5470.00	57.7 PK	74.0	-16.3	2.30 H	283	54.0	3.7
2	#5470.00	46.0 AV	54.0	-8.0	2.30 H	283	42.3	3.7
3	*5550.00	105.6 PK			2.30 H	283	101.7	3.9
4	*5550.00	96.5 AV			2.30 H	283	92.6	3.9
5	#5725.00	52.0 PK	74.0	-22.0	2.30 H	283	47.8	4.2
6	#5725.00	41.6 AV	54.0	-12.4	2.30 H	283	37.4	4.2
7	11100.00	51.2 PK	74.0	-22.8	1.57 H	232	36.1	15.1
8	11100.00	39.2 AV	54.0	-14.8	1.57 H	232	24.1	15.1
9	#16650.00	54.8 PK	74.0	-19.2	1.32 H	181	36.8	18.0
10	#16650.00	42.4 AV	54.0	-11.6	1.32 H	181	24.4	18.0

ANTENNA POLARITY & TEST DISTANCE: VERTICAL AT 3 M

NO.	FREQ. (MHz)	EMISSION LEVEL (dBuV/m)	LIMIT (dBuV/m)	MARGIN (dB)	ANTENNA HEIGHT (m)	TABLE ANGLE (Degree)	RAW VALUE (dBuV)	CORRECTION FACTOR (dB/m)
1	#5470.00	64.9 PK	74.0	-9.1	2.75 V	47	61.2	3.7
2	#5470.00	53.2 AV	54.0	-0.8	2.75 V	47	49.5	3.7
3	*5550.00	112.9 PK			2.75 V	38	109.0	3.9
4	*5550.00	103.6 AV			2.75 V	38	99.7	3.9
5	#5725.00	58.9 PK	74.0	-15.1	2.75 V	47	54.7	4.2
6	#5725.00	48.3 AV	54.0	-5.7	2.75 V	47	44.1	4.2
7	11100.00	52.2 PK	74.0	-21.8	1.41 V	342	37.1	15.1
8	11100.00	40.8 AV	54.0	-13.2	1.41 V	342	25.7	15.1
9	#16650.00	56.2 PK	74.0	-17.8	1.45 V	217	38.2	18.0
10	#16650.00	43.8 AV	54.0	-10.2	1.45 V	217	25.8	18.0

Remark:

1. Emission Level(dBuV/m) = Raw Value(dBuV) + Correction Factor(dB/m)
2. Correction Factor(dB/m) = Antenna Factor(dB/m) + Cable Factor(dB)
3. The other emission levels were very low against the limit.
4. Margin value = Emission Level – Limit value
5. " * ": Fundamental frequency.
6. " # ": The radiated frequency is out of the restricted band.

CHANNEL	TX Channel 134	DETECTOR FUNCTION	Peak (PK)
FREQUENCY RANGE	1GHz ~ 40GHz		Average (AV)

ANTENNA POLARITY & TEST DISTANCE: HORIZONTAL AT 3 M								
NO.	FREQ. (MHz)	EMISSION LEVEL (dBuV/m)	LIMIT (dBuV/m)	MARGIN (dB)	ANTENNA HEIGHT (m)	TABLE ANGLE (Degree)	RAW VALUE (dBuV)	CORRECTION FACTOR (dB/m)
1	*5670.00	104.4 PK			2.29 H	283	100.4	4.0
2	*5670.00	94.4 AV			2.29 H	283	90.4	4.0
3	#5725.00	65.7 PK	74.0	-8.3	2.29 H	283	61.5	4.2
4	#5725.00	46.4 AV	54.0	-7.6	2.29 H	283	42.2	4.2
5	11340.00	51.1 PK	74.0	-22.9	1.58 H	226	35.8	15.3
6	11340.00	39.2 AV	54.0	-14.8	1.58 H	226	23.9	15.3
7	#17010.00	55.0 PK	74.0	-19.0	1.24 H	183	35.1	19.9
8	#17010.00	42.2 AV	54.0	-11.8	1.24 H	183	22.3	19.9
ANTENNA POLARITY & TEST DISTANCE: VERTICAL AT 3 M								
NO.	FREQ. (MHz)	EMISSION LEVEL (dBuV/m)	LIMIT (dBuV/m)	MARGIN (dB)	ANTENNA HEIGHT (m)	TABLE ANGLE (Degree)	RAW VALUE (dBuV)	CORRECTION FACTOR (dB/m)
1	*5670.00	110.7 PK			2.76 V	39	106.7	4.0
2	*5670.00	100.9 AV			2.76 V	39	96.9	4.0
3	#5725.00	72.6 PK	74.0	-1.4	2.75 V	34	68.4	4.2
4	#5725.00	53.3 AV	54.0	-0.7	2.75 V	34	49.1	4.2
5	11340.00	52.2 PK	74.0	-21.8	1.40 V	338	36.9	15.3
6	11340.00	40.7 AV	54.0	-13.3	1.40 V	338	25.4	15.3
7	#17010.00	56.9 PK	74.0	-17.1	1.51 V	216	37.0	19.9
8	#17010.00	44.3 AV	54.0	-9.7	1.51 V	216	24.4	19.9

Remark:

1. Emission Level(dBuV/m) = Raw Value(dBuV) + Correction Factor(dB/m)
2. Correction Factor(dB/m) = Antenna Factor(dB/m) + Cable Factor(dB)
3. The other emission levels were very low against the limit.
4. Margin value = Emission Level – Limit value
5. " * ": Fundamental frequency.
6. " # ": The radiated frequency is out of the restricted band.

CHANNEL	TX Channel 142	DETECTOR FUNCTION	Peak (PK)
FREQUENCY RANGE	1GHz ~ 40GHz		Average (AV)

ANTENNA POLARITY & TEST DISTANCE: HORIZONTAL AT 3 M								
NO.	FREQ. (MHz)	EMISSION LEVEL (dBuV/m)	LIMIT (dBuV/m)	MARGIN (dB)	ANTENNA HEIGHT (m)	TABLE ANGLE (Degree)	RAW VALUE (dBuV)	CORRECTION FACTOR (dB/m)
1	#5470.00	53.6 PK	74.0	-20.4	2.38 H	276	49.9	3.7
2	#5470.00	43.0 AV	54.0	-11.0	2.38 H	276	39.3	3.7
3	*5710.00	107.5 PK			2.38 H	276	103.3	4.2
4	*5710.00	97.0 AV			2.38 H	276	92.8	4.2
5	#5850.00	58.1 PK	74.0	-15.9	2.38 H	276	53.9	4.2
6	#5850.00	46.8 AV	54.0	-7.2	2.38 H	276	42.6	4.2
7	11420.00	50.8 PK	74.0	-23.2	1.55 H	231	35.4	15.4
8	11420.00	39.2 AV	54.0	-14.8	1.55 H	231	23.8	15.4
9	#17130.00	54.7 PK	74.0	-19.3	1.33 H	175	34.7	20.0
10	#17130.00	42.1 AV	54.0	-11.9	1.33 H	175	22.1	20.0

ANTENNA POLARITY & TEST DISTANCE: VERTICAL AT 3 M								
NO.	FREQ. (MHz)	EMISSION LEVEL (dBuV/m)	LIMIT (dBuV/m)	MARGIN (dB)	ANTENNA HEIGHT (m)	TABLE ANGLE (Degree)	RAW VALUE (dBuV)	CORRECTION FACTOR (dB/m)
1	#5470.00	60.6 PK	74.0	-13.4	2.29 V	35	56.9	3.7
2	#5470.00	50.2 AV	54.0	-3.8	2.29 V	35	46.5	3.7
3	*5710.00	114.1 PK			2.29 V	35	109.9	4.2
4	*5710.00	103.8 AV			2.29 V	35	99.6	4.2
5	#5850.00	64.4 PK	74.0	-9.6	2.28 V	35	60.2	4.2
6	#5850.00	53.4 AV	54.0	-0.6	2.28 V	35	49.2	4.2
7	11420.00	51.9 PK	74.0	-22.1	1.36 V	334	36.5	15.4
8	11420.00	40.5 AV	54.0	-13.5	1.36 V	334	25.1	15.4
9	#17130.00	56.2 PK	74.0	-17.8	1.45 V	239	36.2	20.0
10	#17130.00	44.0 AV	54.0	-10.0	1.45 V	239	24.0	20.0

Remark:

1. Emission Level(dBuV/m) = Raw Value(dBuV) + Correction Factor(dB/m)
2. Correction Factor(dB/m) = Antenna Factor(dB/m) + Cable Factor(dB)
3. The other emission levels were very low against the limit.
4. Margin value = Emission Level – Limit value
5. " * " : Fundamental frequency.
6. " # " : The radiated frequency is out of the restricted band.

802.11ac (VHT80)

CHANNEL	TX Channel 58	DETECTOR FUNCTION	Peak (PK)
FREQUENCY RANGE	1GHz ~ 40GHz		Average (AV)

ANTENNA POLARITY & TEST DISTANCE: HORIZONTAL AT 3 M

NO.	FREQ. (MHz)	EMISSION LEVEL (dBuV/m)	LIMIT (dBuV/m)	MARGIN (dB)	ANTENNA HEIGHT (m)	TABLE ANGLE (Degree)	RAW VALUE (dBuV)	CORRECTION FACTOR (dB/m)
1	5150.00	48.9 PK	74.0	-25.1	2.32 H	290	45.9	3.0
2	5150.00	38.7 AV	54.0	-15.3	2.32 H	290	35.7	3.0
3	*5290.00	94.4 PK			2.32 H	290	91.1	3.3
4	*5290.00	85.2 AV			2.32 H	290	81.9	3.3
5	5350.00	59.7 PK	74.0	-14.3	2.32 H	290	56.2	3.5
6	5350.00	46.9 AV	54.0	-7.1	2.32 H	290	43.4	3.5
7	#10580.00	51.1 PK	74.0	-22.9	1.60 H	246	36.8	14.3
8	#10580.00	39.3 AV	54.0	-14.7	1.60 H	246	25.0	14.3
9	15870.00	55.5 PK	74.0	-18.5	1.23 H	164	40.5	15.0
10	15870.00	42.7 AV	54.0	-11.3	1.23 H	164	27.7	15.0

ANTENNA POLARITY & TEST DISTANCE: VERTICAL AT 3 M

NO.	FREQ. (MHz)	EMISSION LEVEL (dBuV/m)	LIMIT (dBuV/m)	MARGIN (dB)	ANTENNA HEIGHT (m)	TABLE ANGLE (Degree)	RAW VALUE (dBuV)	CORRECTION FACTOR (dB/m)
1	5150.00	53.4 PK	74.0	-20.6	2.32 V	325	50.4	3.0
2	5150.00	42.1 AV	54.0	-11.9	2.32 V	325	39.1	3.0
3	*5290.00	101.0 PK			2.49 V	322	97.7	3.3
4	*5290.00	92.1 AV			2.49 V	322	88.8	3.3
5	5350.00	66.5 PK	74.0	-7.5	2.77 V	324	63.0	3.5
6	5350.00	53.6 AV	54.0	-0.4	2.77 V	324	50.1	3.5
7	#10580.00	51.4 PK	74.0	-22.6	1.39 V	345	37.1	14.3
8	#10580.00	40.3 AV	54.0	-13.7	1.39 V	345	26.0	14.3
9	15870.00	56.4 PK	74.0	-17.6	1.52 V	210	41.4	15.0
10	15870.00	44.0 AV	54.0	-10.0	1.52 V	210	29.0	15.0

Remark:

1. Emission Level(dBuV/m) = Raw Value(dBuV) + Correction Factor(dB/m)
2. Correction Factor(dB/m) = Antenna Factor(dB/m) + Cable Factor(dB)
3. The other emission levels were very low against the limit.
4. Margin value = Emission Level – Limit value
5. " * ": Fundamental frequency.
6. " # ": The radiated frequency is out of the restricted band.

CHANNEL	TX Channel 106	DETECTOR FUNCTION	Peak (PK)
FREQUENCY RANGE	1GHz ~ 40GHz		Average (AV)

ANTENNA POLARITY & TEST DISTANCE: HORIZONTAL AT 3 M

NO.	FREQ. (MHz)	EMISSION LEVEL (dBuV/m)	LIMIT (dBuV/m)	MARGIN (dB)	ANTENNA HEIGHT (m)	TABLE ANGLE (Degree)	RAW VALUE (dBuV)	CORRECTION FACTOR (dB/m)
1	#5470.00	62.2 PK	74.0	-11.8	2.27 H	288	58.5	3.7
2	#5470.00	45.8 AV	54.0	-8.2	2.27 H	288	42.1	3.7
3	*5530.00	95.5 PK			2.27 H	288	91.6	3.9
4	*5530.00	86.2 AV			2.27 H	288	82.3	3.9
5	#5725.00	49.2 PK	74.0	-24.8	2.27 H	288	45.0	4.2
6	#5725.00	39.1 AV	54.0	-14.9	2.27 H	288	34.9	4.2
7	11060.00	50.9 PK	74.0	-23.1	1.56 H	242	35.8	15.1
8	11060.00	39.1 AV	54.0	-14.9	1.56 H	242	24.0	15.1
9	#16590.00	55.1 PK	74.0	-18.9	1.25 H	157	37.4	17.7
10	#16590.00	42.6 AV	54.0	-11.4	1.25 H	157	24.9	17.7

ANTENNA POLARITY & TEST DISTANCE: VERTICAL AT 3 M

NO.	FREQ. (MHz)	EMISSION LEVEL (dBuV/m)	LIMIT (dBuV/m)	MARGIN (dB)	ANTENNA HEIGHT (m)	TABLE ANGLE (Degree)	RAW VALUE (dBuV)	CORRECTION FACTOR (dB/m)
1	#5470.00	69.9 PK	74.0	-4.1	2.91 V	50	66.2	3.7
2	#5470.00	53.3 AV	54.0	-0.7	2.91 V	50	49.6	3.7
3	*5530.00	102.4 PK			2.95 V	50	98.5	3.9
4	*5530.00	93.2 AV			2.95 V	50	89.3	3.9
5	#5725.00	51.8 PK	74.0	-22.2	2.91 V	51	47.6	4.2
6	#5725.00	41.5 AV	54.0	-12.5	2.91 V	51	37.3	4.2
7	11060.00	51.5 PK	74.0	-22.5	1.32 V	341	36.4	15.1
8	11060.00	40.4 AV	54.0	-13.6	1.32 V	341	25.3	15.1
9	#16590.00	57.0 PK	74.0	-17.0	1.42 V	228	39.3	17.7
10	#16590.00	44.3 AV	54.0	-9.7	1.42 V	228	26.6	17.7

Remark:

1. Emission Level(dBuV/m) = Raw Value(dBuV) + Correction Factor(dB/m)
2. Correction Factor(dB/m) = Antenna Factor(dB/m) + Cable Factor(dB)
3. The other emission levels were very low against the limit.
4. Margin value = Emission Level – Limit value
5. " * ": Fundamental frequency.
6. " # ": The radiated frequency is out of the restricted band.

CHANNEL	TX Channel 122	DETECTOR FUNCTION	Peak (PK)
FREQUENCY RANGE	1GHz ~ 40GHz		Average (AV)

ANTENNA POLARITY & TEST DISTANCE: HORIZONTAL AT 3 M

NO.	FREQ. (MHz)	EMISSION LEVEL (dBuV/m)	LIMIT (dBuV/m)	MARGIN (dB)	ANTENNA HEIGHT (m)	TABLE ANGLE (Degree)	RAW VALUE (dBuV)	CORRECTION FACTOR (dB/m)
1	#5470.00	58.3 PK	74.0	-15.7	2.32 H	273	54.6	3.7
2	#5470.00	44.8 AV	54.0	-9.2	2.32 H	273	41.1	3.7
3	*5610.00	100.6 PK			2.32 H	273	96.7	3.9
4	*5610.00	91.0 AV			2.32 H	273	87.1	3.9
5	#5725.00	61.7 PK	74.0	-12.3	2.32 H	273	57.5	4.2
6	#5725.00	46.7 AV	54.0	-7.3	2.32 H	273	42.5	4.2
7	11220.00	50.8 PK	74.0	-23.2	1.56 H	222	35.6	15.2
8	11220.00	38.8 AV	54.0	-15.2	1.56 H	222	23.6	15.2
9	#16830.00	55.3 PK	74.0	-18.7	1.31 H	175	36.8	18.5
10	#16830.00	42.3 AV	54.0	-11.7	1.31 H	175	23.8	18.5

ANTENNA POLARITY & TEST DISTANCE: VERTICAL AT 3 M

NO.	FREQ. (MHz)	EMISSION LEVEL (dBuV/m)	LIMIT (dBuV/m)	MARGIN (dB)	ANTENNA HEIGHT (m)	TABLE ANGLE (Degree)	RAW VALUE (dBuV)	CORRECTION FACTOR (dB/m)
1	#5470.00	65.4 PK	74.0	-8.6	2.94 V	50	61.7	3.7
2	#5470.00	51.9 AV	54.0	-2.1	2.94 V	50	48.2	3.7
3	*5610.00	107.7 PK			2.94 V	50	103.8	3.9
4	*5610.00	97.9 AV			2.94 V	50	94.0	3.9
5	#5725.00	68.9 PK	74.0	-5.1	2.94 V	35	64.7	4.2
6	#5725.00	53.8 AV	54.0	-0.2	2.94 V	35	49.6	4.2
7	11220.00	51.7 PK	74.0	-22.3	1.43 V	356	36.5	15.2
8	11220.00	40.8 AV	54.0	-13.2	1.43 V	356	25.6	15.2
9	#16830.00	57.4 PK	74.0	-16.6	1.47 V	225	38.9	18.5
10	#16830.00	44.7 AV	54.0	-9.3	1.47 V	225	26.2	18.5

Remark:

1. Emission Level(dBuV/m) = Raw Value(dBuV) + Correction Factor(dB/m)
2. Correction Factor(dB/m) = Antenna Factor(dB/m) + Cable Factor(dB)
3. The other emission levels were very low against the limit.
4. Margin value = Emission Level – Limit value
5. " * ": Fundamental frequency.
6. " # ": The radiated frequency is out of the restricted band.

CHANNEL	TX Channel 138	DETECTOR FUNCTION	Peak (PK)
FREQUENCY RANGE	1GHz ~ 40GHz		Average (AV)

ANTENNA POLARITY & TEST DISTANCE: HORIZONTAL AT 3 M								
NO.	FREQ. (MHz)	EMISSION LEVEL (dBuV/m)	LIMIT (dBuV/m)	MARGIN (dB)	ANTENNA HEIGHT (m)	TABLE ANGLE (Degree)	RAW VALUE (dBuV)	CORRECTION FACTOR (dB/m)
1	#5470.00	55.1 PK	74.0	-18.9	2.36 H	281	51.4	3.7
2	#5470.00	42.0 AV	54.0	-12.0	2.36 H	281	38.3	3.7
3	*5690.00	102.7 PK			2.36 H	281	98.5	4.2
4	*5690.00	91.6 AV			2.36 H	281	87.4	4.2
5	#5850.00	61.3 PK	74.0	-12.7	2.36 H	281	57.1	4.2
6	#5850.00	46.9 AV	54.0	-7.1	2.36 H	281	42.7	4.2
7	11380.00	50.3 PK	74.0	-23.7	1.55 H	230	34.9	15.4
8	11380.00	38.5 AV	54.0	-15.5	1.55 H	230	23.1	15.4
9	#17070.00	55.4 PK	74.0	-18.6	1.24 H	184	35.4	20.0
10	#17070.00	42.4 AV	54.0	-11.6	1.24 H	184	22.4	20.0

ANTENNA POLARITY & TEST DISTANCE: VERTICAL AT 3 M								
NO.	FREQ. (MHz)	EMISSION LEVEL (dBuV/m)	LIMIT (dBuV/m)	MARGIN (dB)	ANTENNA HEIGHT (m)	TABLE ANGLE (Degree)	RAW VALUE (dBuV)	CORRECTION FACTOR (dB/m)
1	#5470.00	62.5 PK	74.0	-11.5	2.94 V	51	58.8	3.7
2	#5470.00	49.2 AV	54.0	-4.8	2.94 V	51	45.5	3.7
3	*5690.00	109.8 PK			2.94 V	37	105.6	4.2
4	*5690.00	98.9 AV			2.94 V	37	94.7	4.2
5	#5850.00	68.1 PK	74.0	-5.9	2.94 V	51	63.9	4.2
6	#5850.00	53.4 AV	54.0	-0.6	2.94 V	51	49.2	4.2
7	11380.00	51.6 PK	74.0	-22.4	1.42 V	343	36.2	15.4
8	11380.00	40.4 AV	54.0	-13.6	1.42 V	343	25.0	15.4
9	#17070.00	56.5 PK	74.0	-17.5	1.51 V	213	36.5	20.0
10	#17070.00	43.9 AV	54.0	-10.1	1.51 V	213	23.9	20.0

Remark:

1. Emission Level(dBuV/m) = Raw Value(dBuV) + Correction Factor(dB/m)
2. Correction Factor(dB/m) = Antenna Factor(dB/m) + Cable Factor(dB)
3. The other emission levels were very low against the limit.
4. Margin value = Emission Level – Limit value
5. " * " : Fundamental frequency.
6. " # " : The radiated frequency is out of the restricted band.

Radio 2 - 4TX with PIFA antenna CDD Mode

802.11a

CHANNEL	TX Channel 52	DETECTOR FUNCTION	Peak (PK)
FREQUENCY RANGE	1GHz ~ 40GHz		Average (AV)

ANTENNA POLARITY & TEST DISTANCE: HORIZONTAL AT 3 M

NO.	FREQ. (MHz)	EMISSION LEVEL (dBuV/m)	LIMIT (dBuV/m)	MARGIN (dB)	ANTENNA HEIGHT (m)	TABLE ANGLE (Degree)	RAW VALUE (dBuV)	CORRECTION FACTOR (dB/m)
1	5100.00	49.7 PK	74.0	-24.3	1.09 H	142	46.9	2.8
2	5100.00	39.5 AV	54.0	-14.5	1.09 H	142	36.7	2.8
3	*5260.00	101.4 PK			1.09 H	142	98.1	3.3
4	*5260.00	93.6 AV			1.09 H	142	90.3	3.3
5	#10520.00	50.4 PK	74.0	-23.6	1.47 H	332	36.3	14.1
6	#10520.00	39.2 AV	54.0	-14.8	1.47 H	332	25.1	14.1
7	15780.00	51.1 PK	74.0	-22.9	1.50 H	156	35.9	15.2
8	15780.00	40.9 AV	54.0	-13.1	1.50 H	156	25.7	15.2

ANTENNA POLARITY & TEST DISTANCE: VERTICAL AT 3 M

NO.	FREQ. (MHz)	EMISSION LEVEL (dBuV/m)	LIMIT (dBuV/m)	MARGIN (dB)	ANTENNA HEIGHT (m)	TABLE ANGLE (Degree)	RAW VALUE (dBuV)	CORRECTION FACTOR (dB/m)
1	5100.00	50.0 PK	74.0	-24.0	2.84 V	44	47.2	2.8
2	5100.00	40.4 AV	54.0	-13.6	2.84 V	44	37.6	2.8
3	*5260.00	111.6 PK			2.84 V	44	108.3	3.3
4	*5260.00	104.5 AV			2.84 V	44	101.2	3.3
5	#10520.00	50.6 PK	74.0	-23.4	1.00 V	356	36.5	14.1
6	#10520.00	39.4 AV	54.0	-14.6	1.00 V	356	25.3	14.1
7	15780.00	51.8 PK	74.0	-22.2	1.02 V	360	36.6	15.2
8	15780.00	41.4 AV	54.0	-12.6	1.02 V	360	26.2	15.2

Remark:

1. Emission Level(dBuV/m) = Raw Value(dBuV) + Correction Factor(dB/m)
2. Correction Factor(dB/m) = Antenna Factor(dB/m) + Cable Factor(dB)
3. The other emission levels were very low against the limit.
4. Margin value = Emission Level – Limit value
5. " * ": Fundamental frequency.
6. " # ": The radiated frequency is out of the restricted band.

CHANNEL	TX Channel 60	DETECTOR FUNCTION	Peak (PK)
FREQUENCY RANGE	1GHz ~ 40GHz		Average (AV)

ANTENNA POLARITY & TEST DISTANCE: HORIZONTAL AT 3 M								
NO.	FREQ. (MHz)	EMISSION LEVEL (dBuV/m)	LIMIT (dBuV/m)	MARGIN (dB)	ANTENNA HEIGHT (m)	TABLE ANGLE (Degree)	RAW VALUE (dBuV)	CORRECTION FACTOR (dB/m)
1	*5300.00	101.5 PK			1.10 H	128	98.2	3.3
2	*5300.00	93.5 AV			1.10 H	128	90.2	3.3
3	10600.00	50.5 PK	74.0	-23.5	1.49 H	321	36.2	14.3
4	10600.00	39.4 AV	54.0	-14.6	1.49 H	321	25.1	14.3
5	15900.00	50.7 PK	74.0	-23.3	1.52 H	126	35.6	15.1
6	15900.00	40.6 AV	54.0	-13.4	1.52 H	126	25.5	15.1

ANTENNA POLARITY & TEST DISTANCE: VERTICAL AT 3 M								
NO.	FREQ. (MHz)	EMISSION LEVEL (dBuV/m)	LIMIT (dBuV/m)	MARGIN (dB)	ANTENNA HEIGHT (m)	TABLE ANGLE (Degree)	RAW VALUE (dBuV)	CORRECTION FACTOR (dB/m)
1	*5300.00	112.0 PK			2.47 V	299	108.7	3.3
2	*5300.00	104.8 AV			2.47 V	299	101.5	3.3
3	10600.00	50.7 PK	74.0	-23.3	1.00 V	360	36.4	14.3
4	10600.00	39.4 AV	54.0	-14.6	1.00 V	360	25.1	14.3
5	15900.00	51.8 PK	74.0	-22.2	1.00 V	360	36.7	15.1
6	15900.00	41.4 AV	54.0	-12.6	1.00 V	360	26.3	15.1

Remark:

1. Emission Level(dBuV/m) = Raw Value(dBuV) + Correction Factor(dB/m)
2. Correction Factor(dB/m) = Antenna Factor(dB/m) + Cable Factor(dB)
3. The other emission levels were very low against the limit.
4. Margin value = Emission Level – Limit value
5. " * ": Fundamental frequency.
6. " # ": The radiated frequency is out of the restricted band.

CHANNEL	TX Channel 64	DETECTOR FUNCTION	Peak (PK)
FREQUENCY RANGE	1GHz ~ 40GHz		Average (AV)

ANTENNA POLARITY & TEST DISTANCE: HORIZONTAL AT 3 M								
NO.	FREQ. (MHz)	EMISSION LEVEL (dBuV/m)	LIMIT (dBuV/m)	MARGIN (dB)	ANTENNA HEIGHT (m)	TABLE ANGLE (Degree)	RAW VALUE (dBuV)	CORRECTION FACTOR (dB/m)
1	*5320.00	101.9 PK			1.05 H	132	98.4	3.5
2	*5320.00	94.1 AV			1.05 H	132	90.6	3.5
3	5350.00	50.2 PK	74.0	-23.8	1.05 H	132	46.7	3.5
4	5350.00	39.9 AV	54.0	-14.1	1.05 H	132	36.4	3.5
5	10640.00	50.0 PK	74.0	-24.0	1.48 H	318	35.7	14.3
6	10640.00	38.9 AV	54.0	-15.1	1.48 H	318	24.6	14.3
7	15960.00	50.8 PK	74.0	-23.2	1.50 H	130	35.7	15.1
8	15960.00	40.3 AV	54.0	-13.7	1.50 H	130	25.2	15.1
ANTENNA POLARITY & TEST DISTANCE: VERTICAL AT 3 M								
NO.	FREQ. (MHz)	EMISSION LEVEL (dBuV/m)	LIMIT (dBuV/m)	MARGIN (dB)	ANTENNA HEIGHT (m)	TABLE ANGLE (Degree)	RAW VALUE (dBuV)	CORRECTION FACTOR (dB/m)
1	*5320.00	111.1 PK			2.99 V	44	107.6	3.5
2	*5320.00	104.2 AV			2.99 V	44	100.7	3.5
3	5350.00	67.1 PK	74.0	-6.9	2.99 V	44	63.6	3.5
4	5350.00	47.6 AV	54.0	-6.4	2.99 V	44	44.1	3.5
5	10640.00	50.8 PK	74.0	-23.2	1.00 V	360	36.5	14.3
6	10640.00	39.4 AV	54.0	-14.6	1.00 V	360	25.1	14.3
7	15960.00	52.3 PK	74.0	-21.7	1.00 V	360	37.2	15.1
8	15960.00	41.7 AV	54.0	-12.3	1.00 V	360	26.6	15.1

Remark:

1. Emission Level(dBuV/m) = Raw Value(dBuV) + Correction Factor(dB/m)
2. Correction Factor(dB/m) = Antenna Factor(dB/m) + Cable Factor(dB)
3. The other emission levels were very low against the limit.
4. Margin value = Emission Level – Limit value
5. " * ": Fundamental frequency.
6. " # ": The radiated frequency is out of the restricted band.

CHANNEL	TX Channel 100	DETECTOR FUNCTION	Peak (PK)
FREQUENCY RANGE	1GHz ~ 40GHz		Average (AV)

ANTENNA POLARITY & TEST DISTANCE: HORIZONTAL AT 3 M

NO.	FREQ. (MHz)	EMISSION LEVEL (dBuV/m)	LIMIT (dBuV/m)	MARGIN (dB)	ANTENNA HEIGHT (m)	TABLE ANGLE (Degree)	RAW VALUE (dBuV)	CORRECTION FACTOR (dB/m)
1	#5470.00	49.1 PK	74.0	-24.9	1.10 H	137	45.4	3.7
2	#5470.00	38.9 AV	54.0	-15.1	1.10 H	137	35.2	3.7
3	*5500.00	101.3 PK			1.10 H	137	97.5	3.8
4	*5500.00	93.2 AV			1.10 H	137	89.4	3.8
5	11000.00	50.3 PK	74.0	-23.7	1.52 H	302	35.1	15.2
6	11000.00	39.3 AV	54.0	-14.7	1.52 H	302	24.1	15.2
7	#16500.00	51.2 PK	74.0	-22.8	1.55 H	157	33.8	17.4
8	#16500.00	40.9 AV	54.0	-13.1	1.55 H	157	23.5	17.4

ANTENNA POLARITY & TEST DISTANCE: VERTICAL AT 3 M

NO.	FREQ. (MHz)	EMISSION LEVEL (dBuV/m)	LIMIT (dBuV/m)	MARGIN (dB)	ANTENNA HEIGHT (m)	TABLE ANGLE (Degree)	RAW VALUE (dBuV)	CORRECTION FACTOR (dB/m)
1	#5470.00	67.6 PK	74.0	-6.4	2.99 V	295	63.9	3.7
2	#5470.00	47.8 AV	54.0	-6.2	2.99 V	295	44.1	3.7
3	*5500.00	112.1 PK			2.99 V	295	108.3	3.8
4	*5500.00	104.7 AV			2.99 V	295	100.9	3.8
5	11000.00	49.9 PK	74.0	-24.1	1.00 V	351	34.7	15.2
6	11000.00	38.9 AV	54.0	-15.1	1.00 V	351	23.7	15.2
7	#16500.00	52.2 PK	74.0	-21.8	1.00 V	360	34.8	17.4
8	#16500.00	41.9 AV	54.0	-12.1	1.00 V	360	24.5	17.4

Remark:

1. Emission Level(dBuV/m) = Raw Value(dBuV) + Correction Factor(dB/m)
2. Correction Factor(dB/m) = Antenna Factor(dB/m) + Cable Factor(dB)
3. The other emission levels were very low against the limit.
4. Margin value = Emission Level – Limit value
5. " * ": Fundamental frequency.
6. " # ": The radiated frequency is out of the restricted band.

CHANNEL	TX Channel 116	DETECTOR FUNCTION	Peak (PK)
FREQUENCY RANGE	1GHz ~ 40GHz		Average (AV)

ANTENNA POLARITY & TEST DISTANCE: HORIZONTAL AT 3 M								
NO.	FREQ. (MHz)	EMISSION LEVEL (dBuV/m)	LIMIT (dBuV/m)	MARGIN (dB)	ANTENNA HEIGHT (m)	TABLE ANGLE (Degree)	RAW VALUE (dBuV)	CORRECTION FACTOR (dB/m)
1	*5580.00	101.4 PK			1.07 H	128	97.5	3.9
2	*5580.00	93.3 AV			1.07 H	128	89.4	3.9
3	11160.00	50.5 PK	74.0	-23.5	1.52 H	318	35.3	15.2
4	11160.00	39.5 AV	54.0	-14.5	1.52 H	318	24.3	15.2
5	#16740.00	50.6 PK	74.0	-23.4	1.51 H	157	32.3	18.3
6	#16740.00	40.6 AV	54.0	-13.4	1.51 H	157	22.3	18.3

ANTENNA POLARITY & TEST DISTANCE: VERTICAL AT 3 M								
NO.	FREQ. (MHz)	EMISSION LEVEL (dBuV/m)	LIMIT (dBuV/m)	MARGIN (dB)	ANTENNA HEIGHT (m)	TABLE ANGLE (Degree)	RAW VALUE (dBuV)	CORRECTION FACTOR (dB/m)
1	*5580.00	112.0 PK			2.37 V	70	108.1	3.9
2	*5580.00	104.8 AV			2.37 V	70	100.9	3.9
3	11160.00	50.2 PK	74.0	-23.8	1.00 V	360	35.0	15.2
4	11160.00	39.3 AV	54.0	-14.7	1.00 V	360	24.1	15.2
5	#16740.00	51.6 PK	74.0	-22.4	1.08 V	360	33.3	18.3
6	#16740.00	41.4 AV	54.0	-12.6	1.08 V	360	23.1	18.3

Remark:

1. Emission Level(dBuV/m) = Raw Value(dBuV) + Correction Factor(dB/m)
2. Correction Factor(dB/m) = Antenna Factor(dB/m) + Cable Factor(dB)
3. The other emission levels were very low against the limit.
4. Margin value = Emission Level – Limit value
5. " * ": Fundamental frequency.
6. " # ": The radiated frequency is out of the restricted band.

CHANNEL	TX Channel 140	DETECTOR FUNCTION	Peak (PK)
FREQUENCY RANGE	1GHz ~ 40GHz		Average (AV)

ANTENNA POLARITY & TEST DISTANCE: HORIZONTAL AT 3 M								
NO.	FREQ. (MHz)	EMISSION LEVEL (dBuV/m)	LIMIT (dBuV/m)	MARGIN (dB)	ANTENNA HEIGHT (m)	TABLE ANGLE (Degree)	RAW VALUE (dBuV)	CORRECTION FACTOR (dB/m)
1	*5700.00	101.2 PK			1.07 H	131	97.0	4.2
2	*5700.00	93.4 AV			1.07 H	131	89.2	4.2
3	#5725.00	49.4 PK	74.0	-24.6	1.07 H	131	45.2	4.2
4	#5725.00	38.9 AV	54.0	-15.1	1.07 H	131	34.7	4.2
5	11400.00	49.6 PK	74.0	-24.4	1.47 H	313	34.1	15.5
6	11400.00	38.8 AV	54.0	-15.2	1.47 H	313	23.3	15.5
7	#17100.00	50.7 PK	74.0	-23.3	1.50 H	140	30.6	20.1
8	#17100.00	40.5 AV	54.0	-13.5	1.50 H	140	20.4	20.1
ANTENNA POLARITY & TEST DISTANCE: VERTICAL AT 3 M								
NO.	FREQ. (MHz)	EMISSION LEVEL (dBuV/m)	LIMIT (dBuV/m)	MARGIN (dB)	ANTENNA HEIGHT (m)	TABLE ANGLE (Degree)	RAW VALUE (dBuV)	CORRECTION FACTOR (dB/m)
1	*5700.00	111.0 PK			2.58 V	298	106.8	4.2
2	*5700.00	104.2 AV			2.58 V	298	100.0	4.2
3	#5725.00	67.9 PK	74.0	-6.1	2.58 V	298	63.7	4.2
4	#5725.00	48.1 AV	54.0	-5.9	2.58 V	298	43.9	4.2
5	11400.00	50.3 PK	74.0	-23.7	1.00 V	360	34.8	15.5
6	11400.00	39.2 AV	54.0	-14.8	1.00 V	360	23.7	15.5
7	#17100.00	52.1 PK	74.0	-21.9	1.00 V	360	32.0	20.1
8	#17100.00	41.5 AV	54.0	-12.5	1.00 V	360	21.4	20.1

Remark:

1. Emission Level(dBuV/m) = Raw Value(dBuV) + Correction Factor(dB/m)
2. Correction Factor(dB/m) = Antenna Factor(dB/m) + Cable Factor(dB)
3. The other emission levels were very low against the limit.
4. Margin value = Emission Level – Limit value
5. " * ": Fundamental frequency.
6. " # ": The radiated frequency is out of the restricted band.

CHANNEL	TX Channel 144	DETECTOR FUNCTION	Peak (PK)
FREQUENCY RANGE	1GHz ~ 40GHz		Average (AV)

ANTENNA POLARITY & TEST DISTANCE: HORIZONTAL AT 3 M

NO.	FREQ. (MHz)	EMISSION LEVEL (dBuV/m)	LIMIT (dBuV/m)	MARGIN (dB)	ANTENNA HEIGHT (m)	TABLE ANGLE (Degree)	RAW VALUE (dBuV)	CORRECTION FACTOR (dB/m)
1	#5470.00	49.0 PK	74.0	-25.0	1.05 H	118	45.3	3.7
2	#5470.00	38.7 AV	54.0	-15.3	1.05 H	118	35.0	3.7
3	*5720.00	101.2 PK			1.05 H	118	97.0	4.2
4	*5720.00	93.6 AV			1.05 H	118	89.4	4.2
5	#5880.00	49.4 PK	74.0	-24.6	1.05 H	118	45.2	4.2
6	#5880.00	39.0 AV	54.0	-15.0	1.05 H	118	34.8	4.2
7	11440.00	49.2 PK	74.0	-24.8	1.43 H	312	33.9	15.3
8	11440.00	38.7 AV	54.0	-15.3	1.43 H	312	23.4	15.3
9	#17160.00	50.6 PK	74.0	-23.4	1.51 H	124	30.8	19.8
10	#17160.00	40.4 AV	54.0	-13.6	1.51 H	124	20.6	19.8

ANTENNA POLARITY & TEST DISTANCE: VERTICAL AT 3 M

NO.	FREQ. (MHz)	EMISSION LEVEL (dBuV/m)	LIMIT (dBuV/m)	MARGIN (dB)	ANTENNA HEIGHT (m)	TABLE ANGLE (Degree)	RAW VALUE (dBuV)	CORRECTION FACTOR (dB/m)
1	#5470.00	49.0 PK	74.0	-25.0	2.55 V	292	45.3	3.7
2	#5470.00	38.6 AV	54.0	-15.4	2.55 V	292	34.9	3.7
3	*5720.00	111.5 PK			2.55 V	292	107.3	4.2
4	*5720.00	104.7 AV			2.55 V	292	100.5	4.2
5	#5880.00	49.7 PK	74.0	-24.3	2.55 V	292	45.5	4.2
6	#5880.00	39.0 AV	54.0	-15.0	2.55 V	292	34.8	4.2
7	11440.00	50.7 PK	74.0	-23.3	1.02 V	360	35.4	15.3
8	11440.00	39.7 AV	54.0	-14.3	1.02 V	360	24.4	15.3
9	#17160.00	52.0 PK	74.0	-22.0	1.09 V	354	32.2	19.8
10	#17160.00	41.9 AV	54.0	-12.1	1.09 V	354	22.1	19.8

Remark:

1. Emission Level(dBuV/m) = Raw Value(dBuV) + Correction Factor(dB/m)
2. Correction Factor(dB/m) = Antenna Factor(dB/m) + Cable Factor(dB)
3. The other emission levels were very low against the limit.
4. Margin value = Emission Level – Limit value
5. " * ": Fundamental frequency.
6. " # ": The radiated frequency is out of the restricted band.

802.11ac (VHT20)

CHANNEL	TX Channel 52	DETECTOR FUNCTION	Peak (PK)
FREQUENCY RANGE	1GHz ~ 40GHz		Average (AV)

ANTENNA POLARITY & TEST DISTANCE: HORIZONTAL AT 3 M

NO.	FREQ. (MHz)	EMISSION LEVEL (dBuV/m)	LIMIT (dBuV/m)	MARGIN (dB)	ANTENNA HEIGHT (m)	TABLE ANGLE (Degree)	RAW VALUE (dBuV)	CORRECTION FACTOR (dB/m)
1	5100.00	49.0 PK	74.0	-25.0	1.13 H	147	46.2	2.8
2	5100.00	38.9 AV	54.0	-15.1	1.13 H	147	36.1	2.8
3	*5260.00	101.9 PK			1.13 H	147	98.6	3.3
4	*5260.00	94.0 AV			1.13 H	147	90.7	3.3
5	#10520.00	50.1 PK	74.0	-23.9	1.54 H	320	36.0	14.1
6	#10520.00	39.1 AV	54.0	-14.9	1.54 H	320	25.0	14.1
7	15780.00	50.7 PK	74.0	-23.3	1.52 H	158	35.5	15.2
8	15780.00	40.3 AV	54.0	-13.7	1.52 H	158	25.1	15.2

ANTENNA POLARITY & TEST DISTANCE: VERTICAL AT 3 M

NO.	FREQ. (MHz)	EMISSION LEVEL (dBuV/m)	LIMIT (dBuV/m)	MARGIN (dB)	ANTENNA HEIGHT (m)	TABLE ANGLE (Degree)	RAW VALUE (dBuV)	CORRECTION FACTOR (dB/m)
1	5100.00	50.1 PK	74.0	-23.9	3.30 V	42	47.3	2.8
2	5100.00	39.6 AV	54.0	-14.4	3.30 V	42	36.8	2.8
3	*5260.00	112.1 PK			3.30 V	42	108.8	3.3
4	*5260.00	104.8 AV			3.30 V	42	101.5	3.3
5	#10520.00	50.0 PK	74.0	-24.0	1.00 V	346	35.9	14.1
6	#10520.00	39.0 AV	54.0	-15.0	1.00 V	346	24.9	14.1
7	15780.00	51.6 PK	74.0	-22.4	1.00 V	356	36.4	15.2
8	15780.00	41.4 AV	54.0	-12.6	1.00 V	356	26.2	15.2

Remark:

1. Emission Level(dBuV/m) = Raw Value(dBuV) + Correction Factor(dB/m)
2. Correction Factor(dB/m) = Antenna Factor(dB/m) + Cable Factor(dB)
3. The other emission levels were very low against the limit.
4. Margin value = Emission Level – Limit value
5. " * ": Fundamental frequency.
6. " # ": The radiated frequency is out of the restricted band.

CHANNEL	TX Channel 60	DETECTOR FUNCTION	Peak (PK)
FREQUENCY RANGE	1GHz ~ 40GHz		Average (AV)

ANTENNA POLARITY & TEST DISTANCE: HORIZONTAL AT 3 M

NO.	FREQ. (MHz)	EMISSION LEVEL (dBuV/m)	LIMIT (dBuV/m)	MARGIN (dB)	ANTENNA HEIGHT (m)	TABLE ANGLE (Degree)	RAW VALUE (dBuV)	CORRECTION FACTOR (dB/m)
1	*5300.00	101.7 PK			1.08 H	137	98.4	3.3
2	*5300.00	93.8 AV			1.08 H	137	90.5	3.3
3	10600.00	50.0 PK	74.0	-24.0	1.52 H	304	35.7	14.3
4	10600.00	39.2 AV	54.0	-14.8	1.52 H	304	24.9	14.3
5	15900.00	50.7 PK	74.0	-23.3	1.43 H	151	35.6	15.1
6	15900.00	40.7 AV	54.0	-13.3	1.43 H	151	25.6	15.1

ANTENNA POLARITY & TEST DISTANCE: VERTICAL AT 3 M

NO.	FREQ. (MHz)	EMISSION LEVEL (dBuV/m)	LIMIT (dBuV/m)	MARGIN (dB)	ANTENNA HEIGHT (m)	TABLE ANGLE (Degree)	RAW VALUE (dBuV)	CORRECTION FACTOR (dB/m)
1	*5300.00	111.2 PK			2.49 V	228	107.9	3.3
2	*5300.00	104.4 AV			2.49 V	228	101.1	3.3
3	10600.00	50.4 PK	74.0	-23.6	1.01 V	360	36.1	14.3
4	10600.00	39.5 AV	54.0	-14.5	1.01 V	360	25.2	14.3
5	15900.00	52.2 PK	74.0	-21.8	1.05 V	360	37.1	15.1
6	15900.00	41.6 AV	54.0	-12.4	1.05 V	360	26.5	15.1

Remark:

1. Emission Level(dBuV/m) = Raw Value(dBuV) + Correction Factor(dB/m)
2. Correction Factor(dB/m) = Antenna Factor(dB/m) + Cable Factor(dB)
3. The other emission levels were very low against the limit.
4. Margin value = Emission Level – Limit value
5. " * ": Fundamental frequency.
6. " # ": The radiated frequency is out of the restricted band.

CHANNEL	TX Channel 64	DETECTOR FUNCTION	Peak (PK)
FREQUENCY RANGE	1GHz ~ 40GHz		Average (AV)

ANTENNA POLARITY & TEST DISTANCE: HORIZONTAL AT 3 M

NO.	FREQ. (MHz)	EMISSION LEVEL (dBuV/m)	LIMIT (dBuV/m)	MARGIN (dB)	ANTENNA HEIGHT (m)	TABLE ANGLE (Degree)	RAW VALUE (dBuV)	CORRECTION FACTOR (dB/m)
1	*5320.00	101.5 PK			1.06 H	140	98.0	3.5
2	*5320.00	93.4 AV			1.06 H	140	89.9	3.5
3	5350.00	50.1 PK	74.0	-23.9	1.06 H	140	46.6	3.5
4	5350.00	39.9 AV	54.0	-14.1	1.06 H	140	36.4	3.5
5	10640.00	49.6 PK	74.0	-24.4	1.56 H	303	35.3	14.3
6	10640.00	38.7 AV	54.0	-15.3	1.56 H	303	24.4	14.3
7	15960.00	50.7 PK	74.0	-23.3	1.43 H	137	35.6	15.1
8	15960.00	40.5 AV	54.0	-13.5	1.43 H	137	25.4	15.1

ANTENNA POLARITY & TEST DISTANCE: VERTICAL AT 3 M

NO.	FREQ. (MHz)	EMISSION LEVEL (dBuV/m)	LIMIT (dBuV/m)	MARGIN (dB)	ANTENNA HEIGHT (m)	TABLE ANGLE (Degree)	RAW VALUE (dBuV)	CORRECTION FACTOR (dB/m)
1	*5320.00	111.0 PK			2.77 V	39	107.5	3.5
2	*5320.00	104.0 AV			2.77 V	39	100.5	3.5
3	5350.00	67.4 PK	74.0	-6.6	2.77 V	39	63.9	3.5
4	5350.00	48.0 AV	54.0	-6.0	2.77 V	39	44.5	3.5
5	10640.00	50.3 PK	74.0	-23.7	1.00 V	360	36.0	14.3
6	10640.00	39.4 AV	54.0	-14.6	1.00 V	360	25.1	14.3
7	15960.00	51.5 PK	74.0	-22.5	1.00 V	360	36.4	15.1
8	15960.00	41.4 AV	54.0	-12.6	1.00 V	360	26.3	15.1

Remark:

1. Emission Level(dBuV/m) = Raw Value(dBuV) + Correction Factor(dB/m)
2. Correction Factor(dB/m) = Antenna Factor(dB/m) + Cable Factor(dB)
3. The other emission levels were very low against the limit.
4. Margin value = Emission Level – Limit value
5. " * ": Fundamental frequency.
6. " # ": The radiated frequency is out of the restricted band.

CHANNEL	TX Channel 100	DETECTOR FUNCTION	Peak (PK)
FREQUENCY RANGE	1GHz ~ 40GHz		Average (AV)

ANTENNA POLARITY & TEST DISTANCE: HORIZONTAL AT 3 M								
NO.	FREQ. (MHz)	EMISSION LEVEL (dBuV/m)	LIMIT (dBuV/m)	MARGIN (dB)	ANTENNA HEIGHT (m)	TABLE ANGLE (Degree)	RAW VALUE (dBuV)	CORRECTION FACTOR (dB/m)
1	#5470.00	49.4 PK	74.0	-24.6	1.09 H	136	45.7	3.7
2	#5470.00	39.4 AV	54.0	-14.6	1.09 H	136	35.7	3.7
3	*5500.00	100.9 PK			1.09 H	136	97.1	3.8
4	*5500.00	93.3 AV			1.09 H	136	89.5	3.8
5	11000.00	49.4 PK	74.0	-24.6	1.52 H	292	34.2	15.2
6	11000.00	38.5 AV	54.0	-15.5	1.52 H	292	23.3	15.2
7	#16500.00	50.6 PK	74.0	-23.4	1.39 H	150	33.2	17.4
8	#16500.00	40.2 AV	54.0	-13.8	1.39 H	150	22.8	17.4
ANTENNA POLARITY & TEST DISTANCE: VERTICAL AT 3 M								
NO.	FREQ. (MHz)	EMISSION LEVEL (dBuV/m)	LIMIT (dBuV/m)	MARGIN (dB)	ANTENNA HEIGHT (m)	TABLE ANGLE (Degree)	RAW VALUE (dBuV)	CORRECTION FACTOR (dB/m)
1	#5470.00	66.9 PK	74.0	-7.1	2.59 V	220	63.2	3.7
2	#5470.00	47.4 AV	54.0	-6.6	2.59 V	220	43.7	3.7
3	*5500.00	111.6 PK			2.59 V	220	107.8	3.8
4	*5500.00	104.7 AV			2.59 V	220	100.9	3.8
5	11000.00	50.6 PK	74.0	-23.4	1.00 V	360	35.4	15.2
6	11000.00	39.4 AV	54.0	-14.6	1.00 V	360	24.2	15.2
7	#16500.00	52.4 PK	74.0	-21.6	1.00 V	353	35.0	17.4
8	#16500.00	41.8 AV	54.0	-12.2	1.00 V	353	24.4	17.4

Remark:

1. Emission Level(dBuV/m) = Raw Value(dBuV) + Correction Factor(dB/m)
2. Correction Factor(dB/m) = Antenna Factor(dB/m) + Cable Factor(dB)
3. The other emission levels were very low against the limit.
4. Margin value = Emission Level – Limit value
5. " * ": Fundamental frequency.
6. " # ": The radiated frequency is out of the restricted band.

CHANNEL	TX Channel 116	DETECTOR FUNCTION	Peak (PK)
FREQUENCY RANGE	1GHz ~ 40GHz		Average (AV)

ANTENNA POLARITY & TEST DISTANCE: HORIZONTAL AT 3 M								
NO.	FREQ. (MHz)	EMISSION LEVEL (dBuV/m)	LIMIT (dBuV/m)	MARGIN (dB)	ANTENNA HEIGHT (m)	TABLE ANGLE (Degree)	RAW VALUE (dBuV)	CORRECTION FACTOR (dB/m)
1	*5580.00	101.9 PK			1.14 H	128	98.0	3.9
2	*5580.00	93.8 AV			1.14 H	128	89.9	3.9
3	11160.00	49.8 PK	74.0	-24.2	1.58 H	306	34.6	15.2
4	11160.00	38.8 AV	54.0	-15.2	1.58 H	306	23.6	15.2
5	#16740.00	50.5 PK	74.0	-23.5	1.47 H	139	32.2	18.3
6	#16740.00	40.4 AV	54.0	-13.6	1.47 H	139	22.1	18.3

ANTENNA POLARITY & TEST DISTANCE: VERTICAL AT 3 M								
NO.	FREQ. (MHz)	EMISSION LEVEL (dBuV/m)	LIMIT (dBuV/m)	MARGIN (dB)	ANTENNA HEIGHT (m)	TABLE ANGLE (Degree)	RAW VALUE (dBuV)	CORRECTION FACTOR (dB/m)
1	*5580.00	111.1 PK			2.96 V	315	107.2	3.9
2	*5580.00	104.1 AV			2.96 V	315	100.2	3.9
3	11160.00	50.3 PK	74.0	-23.7	1.00 V	360	35.1	15.2
4	11160.00	39.0 AV	54.0	-15.0	1.00 V	360	23.8	15.2
5	#16740.00	51.8 PK	74.0	-22.2	1.03 V	355	33.5	18.3
6	#16740.00	41.4 AV	54.0	-12.6	1.03 V	355	23.1	18.3

Remark:

1. Emission Level(dBuV/m) = Raw Value(dBuV) + Correction Factor(dB/m)
2. Correction Factor(dB/m) = Antenna Factor(dB/m) + Cable Factor(dB)
3. The other emission levels were very low against the limit.
4. Margin value = Emission Level – Limit value
5. " * ": Fundamental frequency.
6. " # ": The radiated frequency is out of the restricted band.

CHANNEL	TX Channel 140	DETECTOR FUNCTION	Peak (PK)
FREQUENCY RANGE	1GHz ~ 40GHz		Average (AV)

ANTENNA POLARITY & TEST DISTANCE: HORIZONTAL AT 3 M								
NO.	FREQ. (MHz)	EMISSION LEVEL (dBuV/m)	LIMIT (dBuV/m)	MARGIN (dB)	ANTENNA HEIGHT (m)	TABLE ANGLE (Degree)	RAW VALUE (dBuV)	CORRECTION FACTOR (dB/m)
1	*5700.00	101.3 PK			1.05 H	153	97.1	4.2
2	*5700.00	93.6 AV			1.05 H	153	89.4	4.2
3	#5725.00	49.5 PK	74.0	-24.5	1.05 H	153	45.3	4.2
4	#5725.00	39.1 AV	54.0	-14.9	1.05 H	153	34.9	4.2
5	11400.00	48.9 PK	74.0	-25.1	1.54 H	310	33.4	15.5
6	11400.00	38.3 AV	54.0	-15.7	1.54 H	310	22.8	15.5
7	#17100.00	50.0 PK	74.0	-24.0	1.49 H	130	29.9	20.1
8	#17100.00	40.1 AV	54.0	-13.9	1.49 H	130	20.0	20.1
ANTENNA POLARITY & TEST DISTANCE: VERTICAL AT 3 M								
NO.	FREQ. (MHz)	EMISSION LEVEL (dBuV/m)	LIMIT (dBuV/m)	MARGIN (dB)	ANTENNA HEIGHT (m)	TABLE ANGLE (Degree)	RAW VALUE (dBuV)	CORRECTION FACTOR (dB/m)
1	*5700.00	111.6 PK			3.48 V	132	107.4	4.2
2	*5700.00	104.4 AV			3.48 V	132	100.2	4.2
3	#5725.00	66.3 PK	74.0	-7.7	3.48 V	132	62.1	4.2
4	#5725.00	47.1 AV	54.0	-6.9	3.48 V	132	42.9	4.2
5	11400.00	50.4 PK	74.0	-23.6	1.00 V	357	34.9	15.5
6	11400.00	39.0 AV	54.0	-15.0	1.00 V	357	23.5	15.5
7	#17100.00	52.0 PK	74.0	-22.0	1.06 V	360	31.9	20.1
8	#17100.00	41.3 AV	54.0	-12.7	1.06 V	360	21.2	20.1

Remark:

1. Emission Level(dBuV/m) = Raw Value(dBuV) + Correction Factor(dB/m)
2. Correction Factor(dB/m) = Antenna Factor(dB/m) + Cable Factor(dB)
3. The other emission levels were very low against the limit.
4. Margin value = Emission Level – Limit value
5. " * ": Fundamental frequency.
6. " # ": The radiated frequency is out of the restricted band.

CHANNEL	TX Channel 144	DETECTOR FUNCTION	Peak (PK)
FREQUENCY RANGE	1GHz ~ 40GHz		Average (AV)

ANTENNA POLARITY & TEST DISTANCE: HORIZONTAL AT 3 M								
NO.	FREQ. (MHz)	EMISSION LEVEL (dBuV/m)	LIMIT (dBuV/m)	MARGIN (dB)	ANTENNA HEIGHT (m)	TABLE ANGLE (Degree)	RAW VALUE (dBuV)	CORRECTION FACTOR (dB/m)
1	#5470.00	49.8 PK	74.0	-24.2	1.06 H	141	46.1	3.7
2	#5470.00	39.5 AV	54.0	-14.5	1.06 H	141	35.8	3.7
3	*5720.00	101.4 PK			1.06 H	141	97.2	4.2
4	*5720.00	93.9 AV			1.06 H	141	89.7	4.2
5	#5850.00	49.7 PK	74.0	-24.3	1.06 H	141	45.5	4.2
6	#5850.00	39.3 AV	54.0	-14.7	1.06 H	141	35.1	4.2
7	11440.00	48.7 PK	74.0	-25.3	1.56 H	306	33.4	15.3
8	11440.00	38.2 AV	54.0	-15.8	1.56 H	306	22.9	15.3
9	#17160.00	51.2 PK	74.0	-22.8	1.44 H	158	31.4	19.8
10	#17160.00	40.9 AV	54.0	-13.1	1.44 H	158	21.1	19.8

ANTENNA POLARITY & TEST DISTANCE: VERTICAL AT 3 M								
NO.	FREQ. (MHz)	EMISSION LEVEL (dBuV/m)	LIMIT (dBuV/m)	MARGIN (dB)	ANTENNA HEIGHT (m)	TABLE ANGLE (Degree)	RAW VALUE (dBuV)	CORRECTION FACTOR (dB/m)
1	#5470.00	49.7 PK	74.0	-24.3	3.49 V	126	46.0	3.7
2	#5470.00	39.5 AV	54.0	-14.5	3.49 V	126	35.8	3.7
3	*5720.00	111.6 PK			3.49 V	126	107.4	4.2
4	*5720.00	104.4 AV			3.49 V	126	100.2	4.2
5	#5850.00	49.6 PK	74.0	-24.4	3.49 V	126	45.4	4.2
6	#5850.00	39.5 AV	54.0	-14.5	3.49 V	126	35.3	4.2
7	11440.00	50.5 PK	74.0	-23.5	1.01 V	360	35.2	15.3
8	11440.00	39.1 AV	54.0	-14.9	1.01 V	360	23.8	15.3
9	#17160.00	52.1 PK	74.0	-21.9	1.03 V	360	32.3	19.8
10	#17160.00	41.7 AV	54.0	-12.3	1.03 V	360	21.9	19.8

Remark:

1. Emission Level(dBuV/m) = Raw Value(dBuV) + Correction Factor(dB/m)
2. Correction Factor(dB/m) = Antenna Factor(dB/m) + Cable Factor(dB)
3. The other emission levels were very low against the limit.
4. Margin value = Emission Level – Limit value
5. " * ": Fundamental frequency.
6. " # ": The radiated frequency is out of the restricted band.

802.11ac (VHT40)

CHANNEL	TX Channel 54	DETECTOR FUNCTION	Peak (PK)
FREQUENCY RANGE	1GHz ~ 40GHz		Average (AV)

ANTENNA POLARITY & TEST DISTANCE: HORIZONTAL AT 3 M

NO.	FREQ. (MHz)	EMISSION LEVEL (dBuV/m)	LIMIT (dBuV/m)	MARGIN (dB)	ANTENNA HEIGHT (m)	TABLE ANGLE (Degree)	RAW VALUE (dBuV)	CORRECTION FACTOR (dB/m)
1	5150.00	49.9 PK	74.0	-24.1	1.04 H	134	46.9	3.0
2	5150.00	39.8 AV	54.0	-14.2	1.04 H	134	36.8	3.0
3	*5270.00	100.4 PK			1.04 H	134	97.1	3.3
4	*5270.00	91.6 AV			1.04 H	134	88.3	3.3
5	#10540.00	49.8 PK	74.0	-24.2	1.54 H	309	35.6	14.2
6	#10540.00	38.7 AV	54.0	-15.3	1.54 H	309	24.5	14.2
7	15810.00	51.1 PK	74.0	-22.9	1.49 H	126	36.1	15.0
8	15810.00	40.8 AV	54.0	-13.2	1.49 H	126	25.8	15.0

ANTENNA POLARITY & TEST DISTANCE: VERTICAL AT 3 M

NO.	FREQ. (MHz)	EMISSION LEVEL (dBuV/m)	LIMIT (dBuV/m)	MARGIN (dB)	ANTENNA HEIGHT (m)	TABLE ANGLE (Degree)	RAW VALUE (dBuV)	CORRECTION FACTOR (dB/m)
1	5150.00	56.6 PK	74.0	-17.4	2.62 V	286	53.6	3.0
2	5150.00	50.6 AV	54.0	-3.4	2.62 V	286	47.6	3.0
3	*5270.00	111.6 PK			2.62 V	286	108.3	3.3
4	*5270.00	102.4 AV			2.62 V	286	99.1	3.3
5	#10540.00	50.8 PK	74.0	-23.2	1.00 V	360	36.6	14.2
6	#10540.00	39.2 AV	54.0	-14.8	1.00 V	360	25.0	14.2
7	15810.00	50.6 PK	74.0	-23.4	1.02 V	334	35.6	15.0
8	15810.00	40.4 AV	54.0	-13.6	1.02 V	334	25.4	15.0

Remark:

1. Emission Level(dBuV/m) = Raw Value(dBuV) + Correction Factor(dB/m)
2. Correction Factor(dB/m) = Antenna Factor(dB/m) + Cable Factor(dB)
3. The other emission levels were very low against the limit.
4. Margin value = Emission Level – Limit value
5. " * ": Fundamental frequency.
6. " # ": The radiated frequency is out of the restricted band.

CHANNEL	TX Channel 62	DETECTOR FUNCTION	Peak (PK)
FREQUENCY RANGE	1GHz ~ 40GHz		Average (AV)

ANTENNA POLARITY & TEST DISTANCE: HORIZONTAL AT 3 M								
NO.	FREQ. (MHz)	EMISSION LEVEL (dBuV/m)	LIMIT (dBuV/m)	MARGIN (dB)	ANTENNA HEIGHT (m)	TABLE ANGLE (Degree)	RAW VALUE (dBuV)	CORRECTION FACTOR (dB/m)
1	*5310.00	99.9 PK			1.13 H	128	96.5	3.4
2	*5310.00	90.3 AV			1.13 H	128	86.9	3.4
3	5350.00	49.9 PK	74.0	-24.1	1.13 H	128	46.4	3.5
4	5350.00	39.3 AV	54.0	-14.7	1.13 H	128	35.8	3.5
5	10620.00	50.0 PK	74.0	-24.0	1.51 H	313	35.7	14.3
6	10620.00	38.9 AV	54.0	-15.1	1.51 H	313	24.6	14.3
7	15930.00	50.4 PK	74.0	-23.6	1.41 H	129	35.3	15.1
8	15930.00	40.3 AV	54.0	-13.7	1.41 H	129	25.2	15.1
ANTENNA POLARITY & TEST DISTANCE: VERTICAL AT 3 M								
NO.	FREQ. (MHz)	EMISSION LEVEL (dBuV/m)	LIMIT (dBuV/m)	MARGIN (dB)	ANTENNA HEIGHT (m)	TABLE ANGLE (Degree)	RAW VALUE (dBuV)	CORRECTION FACTOR (dB/m)
1	*5310.00	110.8 PK			2.62 V	245	107.4	3.4
2	*5310.00	101.4 AV			2.62 V	245	98.0	3.4
3	5350.00	70.2 PK	74.0	-3.8	2.62 V	245	66.7	3.5
4	5350.00	52.8 AV	54.0	-1.2	2.62 V	245	49.3	3.5
5	10620.00	50.5 PK	74.0	-23.5	1.00 V	360	36.2	14.3
6	10620.00	38.9 AV	54.0	-15.1	1.00 V	360	24.6	14.3
7	15930.00	50.9 PK	74.0	-23.1	1.00 V	336	35.8	15.1
8	15930.00	40.3 AV	54.0	-13.7	1.00 V	336	25.2	15.1

Remark:

1. Emission Level(dBuV/m) = Raw Value(dBuV) + Correction Factor(dB/m)
2. Correction Factor(dB/m) = Antenna Factor(dB/m) + Cable Factor(dB)
3. The other emission levels were very low against the limit.
4. Margin value = Emission Level – Limit value
5. " * ": Fundamental frequency.
6. " # ": The radiated frequency is out of the restricted band.

CHANNEL	TX Channel 102	DETECTOR FUNCTION	Peak (PK)
FREQUENCY RANGE	1GHz ~ 40GHz		Average (AV)

ANTENNA POLARITY & TEST DISTANCE: HORIZONTAL AT 3 M

NO.	FREQ. (MHz)	EMISSION LEVEL (dBuV/m)	LIMIT (dBuV/m)	MARGIN (dB)	ANTENNA HEIGHT (m)	TABLE ANGLE (Degree)	RAW VALUE (dBuV)	CORRECTION FACTOR (dB/m)
1	#5466.00	57.4 PK	74.0	-16.6	1.10 H	114	53.7	3.7
2	#5466.00	44.9 AV	54.0	-9.1	1.10 H	114	41.2	3.7
3	*5510.00	99.8 PK			1.10 H	114	96.0	3.8
4	*5510.00	89.7 AV			1.10 H	114	85.9	3.8
5	11020.00	49.5 PK	74.0	-24.5	1.51 H	295	34.4	15.1
6	11020.00	38.4 AV	54.0	-15.6	1.51 H	295	23.3	15.1
7	#16530.00	50.4 PK	74.0	-23.6	1.44 H	150	32.9	17.5
8	#16530.00	40.1 AV	54.0	-13.9	1.44 H	150	22.6	17.5

ANTENNA POLARITY & TEST DISTANCE: VERTICAL AT 3 M

NO.	FREQ. (MHz)	EMISSION LEVEL (dBuV/m)	LIMIT (dBuV/m)	MARGIN (dB)	ANTENNA HEIGHT (m)	TABLE ANGLE (Degree)	RAW VALUE (dBuV)	CORRECTION FACTOR (dB/m)
1	#5466.00	68.2 PK	74.0	-5.8	2.22 V	218	64.5	3.7
2	#5466.00	53.4 AV	54.0	-0.6	2.22 V	218	49.7	3.7
3	*5510.00	109.8 PK			2.22 V	218	106.0	3.8
4	*5510.00	100.3 AV			2.22 V	218	96.5	3.8
5	11020.00	50.0 PK	74.0	-24.0	1.02 V	360	34.9	15.1
6	11020.00	38.9 AV	54.0	-15.1	1.02 V	360	23.8	15.1
7	#16530.00	50.4 PK	74.0	-23.6	1.00 V	340	32.9	17.5
8	#16530.00	40.2 AV	54.0	-13.8	1.00 V	340	22.7	17.5

Remark:

1. Emission Level(dBuV/m) = Raw Value(dBuV) + Correction Factor(dB/m)
2. Correction Factor(dB/m) = Antenna Factor(dB/m) + Cable Factor(dB)
3. The other emission levels were very low against the limit.
4. Margin value = Emission Level – Limit value
5. " * ": Fundamental frequency.
6. " # ": The radiated frequency is out of the restricted band.

CHANNEL	TX Channel 110	DETECTOR FUNCTION	Peak (PK)
FREQUENCY RANGE	1GHz ~ 40GHz		Average (AV)

ANTENNA POLARITY & TEST DISTANCE: HORIZONTAL AT 3 M

NO.	FREQ. (MHz)	EMISSION LEVEL (dBuV/m)	LIMIT (dBuV/m)	MARGIN (dB)	ANTENNA HEIGHT (m)	TABLE ANGLE (Degree)	RAW VALUE (dBuV)	CORRECTION FACTOR (dB/m)
1	*5550.00	100.1 PK			1.15 H	113	96.2	3.9
2	*5550.00	90.6 AV			1.15 H	113	86.7	3.9
3	11100.00	49.9 PK	74.0	-24.1	1.60 H	307	34.8	15.1
4	11100.00	38.7 AV	54.0	-15.3	1.60 H	307	23.6	15.1
5	#16650.00	50.6 PK	74.0	-23.4	1.39 H	133	32.6	18.0
6	#16650.00	40.4 AV	54.0	-13.6	1.39 H	133	22.4	18.0

ANTENNA POLARITY & TEST DISTANCE: VERTICAL AT 3 M

NO.	FREQ. (MHz)	EMISSION LEVEL (dBuV/m)	LIMIT (dBuV/m)	MARGIN (dB)	ANTENNA HEIGHT (m)	TABLE ANGLE (Degree)	RAW VALUE (dBuV)	CORRECTION FACTOR (dB/m)
1	*5550.00	111.5 PK			2.82 V	219	107.6	3.9
2	*5550.00	101.9 AV			2.82 V	219	98.0	3.9
3	11100.00	50.3 PK	74.0	-23.7	1.00 V	357	35.2	15.1
4	11100.00	38.9 AV	54.0	-15.1	1.00 V	357	23.8	15.1
5	#16650.00	51.0 PK	74.0	-23.0	1.01 V	354	33.0	18.0
6	#16650.00	40.7 AV	54.0	-13.3	1.01 V	354	22.7	18.0

Remark:

1. Emission Level(dBuV/m) = Raw Value(dBuV) + Correction Factor(dB/m)
2. Correction Factor(dB/m) = Antenna Factor(dB/m) + Cable Factor(dB)
3. The other emission levels were very low against the limit.
4. Margin value = Emission Level – Limit value
5. " * ": Fundamental frequency.
6. " # ": The radiated frequency is out of the restricted band.

CHANNEL	TX Channel 134	DETECTOR FUNCTION	Peak (PK)
FREQUENCY RANGE	1GHz ~ 40GHz		Average (AV)

ANTENNA POLARITY & TEST DISTANCE: HORIZONTAL AT 3 M								
NO.	FREQ. (MHz)	EMISSION LEVEL (dBuV/m)	LIMIT (dBuV/m)	MARGIN (dB)	ANTENNA HEIGHT (m)	TABLE ANGLE (Degree)	RAW VALUE (dBuV)	CORRECTION FACTOR (dB/m)
1	*5670.00	101.6 PK			1.12 H	138	97.6	4.0
2	*5670.00	91.2 AV			1.12 H	138	87.2	4.0
3	#5725.00	56.8 PK	74.0	-17.2	1.12 H	138	52.6	4.2
4	#5725.00	41.3 AV	54.0	-12.7	1.12 H	138	37.1	4.2
5	11340.00	49.6 PK	74.0	-24.4	1.59 H	315	34.3	15.3
6	11340.00	38.4 AV	54.0	-15.6	1.59 H	315	23.1	15.3
7	#17010.00	50.6 PK	74.0	-23.4	1.42 H	149	30.7	19.9
8	#17010.00	40.5 AV	54.0	-13.5	1.42 H	149	20.6	19.9
ANTENNA POLARITY & TEST DISTANCE: VERTICAL AT 3 M								
NO.	FREQ. (MHz)	EMISSION LEVEL (dBuV/m)	LIMIT (dBuV/m)	MARGIN (dB)	ANTENNA HEIGHT (m)	TABLE ANGLE (Degree)	RAW VALUE (dBuV)	CORRECTION FACTOR (dB/m)
1	*5670.00	111.7 PK			2.28 V	221	107.7	4.0
2	*5670.00	102.1 AV			2.28 V	221	98.1	4.0
3	#5725.00	67.1 PK	74.0	-6.9	2.28 V	221	62.9	4.2
4	#5725.00	52.1 AV	54.0	-1.9	2.28 V	221	47.9	4.2
5	11340.00	50.2 PK	74.0	-23.8	1.00 V	360	34.9	15.3
6	11340.00	38.6 AV	54.0	-15.4	1.00 V	360	23.3	15.3
7	#17010.00	50.3 PK	74.0	-23.7	1.01 V	340	30.4	19.9
8	#17010.00	40.0 AV	54.0	-14.0	1.01 V	340	20.1	19.9

Remark:

1. Emission Level(dBuV/m) = Raw Value(dBuV) + Correction Factor(dB/m)
2. Correction Factor(dB/m) = Antenna Factor(dB/m) + Cable Factor(dB)
3. The other emission levels were very low against the limit.
4. Margin value = Emission Level – Limit value
5. " * ": Fundamental frequency.
6. " # ": The radiated frequency is out of the restricted band.

CHANNEL	TX Channel 142	DETECTOR FUNCTION	Peak (PK)
FREQUENCY RANGE	1GHz ~ 40GHz		Average (AV)

ANTENNA POLARITY & TEST DISTANCE: HORIZONTAL AT 3 M								
NO.	FREQ. (MHz)	EMISSION LEVEL (dBuV/m)	LIMIT (dBuV/m)	MARGIN (dB)	ANTENNA HEIGHT (m)	TABLE ANGLE (Degree)	RAW VALUE (dBuV)	CORRECTION FACTOR (dB/m)
1	5460.00	57.2 PK	74.0	-16.8	1.10 H	125	53.5	3.7
2	5460.00	41.4 AV	54.0	-12.6	1.10 H	125	37.7	3.7
3	#5470.00	56.7 PK	74.0	-17.3	1.10 H	125	53.0	3.7
4	#5470.00	41.0 AV	54.0	-13.0	1.10 H	125	37.3	3.7
5	*5710.00	101.8 PK			1.10 H	125	97.6	4.2
6	*5710.00	91.4 AV			1.10 H	125	87.2	4.2
7	11420.00	49.2 PK	74.0	-24.8	1.47 H	313	33.8	15.4
8	11420.00	38.5 AV	54.0	-15.5	1.47 H	313	23.1	15.4
9	#17130.00	50.7 PK	74.0	-23.3	1.40 H	139	30.7	20.0
10	#17130.00	40.6 AV	54.0	-13.4	1.40 H	139	20.6	20.0

ANTENNA POLARITY & TEST DISTANCE: VERTICAL AT 3 M								
NO.	FREQ. (MHz)	EMISSION LEVEL (dBuV/m)	LIMIT (dBuV/m)	MARGIN (dB)	ANTENNA HEIGHT (m)	TABLE ANGLE (Degree)	RAW VALUE (dBuV)	CORRECTION FACTOR (dB/m)
1	5460.00	57.1 PK	74.0	-16.9	2.30 V	223	53.4	3.7
2	5460.00	41.8 AV	54.0	-12.2	2.30 V	223	38.1	3.7
3	#5470.00	57.4 PK	74.0	-16.6	2.30 V	223	53.7	3.7
4	#5470.00	41.7 AV	54.0	-12.3	2.30 V	223	38.0	3.7
5	*5710.00	111.8 PK			2.30 V	223	107.6	4.2
6	*5710.00	102.0 AV			2.30 V	223	97.8	4.2
7	11420.00	50.9 PK	74.0	-23.1	1.00 V	360	35.5	15.4
8	11420.00	39.6 AV	54.0	-14.4	1.00 V	360	24.2	15.4
9	#17130.00	51.9 PK	74.0	-22.1	1.03 V	360	31.9	20.0
10	#17130.00	41.5 AV	54.0	-12.5	1.03 V	360	21.5	20.0

Remark:

1. Emission Level(dBuV/m) = Raw Value(dBuV) + Correction Factor(dB/m)
2. Correction Factor(dB/m) = Antenna Factor(dB/m) + Cable Factor(dB)
3. The other emission levels were very low against the limit.
4. Margin value = Emission Level – Limit value
5. " * ": Fundamental frequency.
6. " # ": The radiated frequency is out of the restricted band.

802.11ac (VHT80)

CHANNEL	TX Channel 58	DETECTOR FUNCTION	Peak (PK)
FREQUENCY RANGE	1GHz ~ 40GHz		Average (AV)

ANTENNA POLARITY & TEST DISTANCE: HORIZONTAL AT 3 M

NO.	FREQ. (MHz)	EMISSION LEVEL (dBuV/m)	LIMIT (dBuV/m)	MARGIN (dB)	ANTENNA HEIGHT (m)	TABLE ANGLE (Degree)	RAW VALUE (dBuV)	CORRECTION FACTOR (dB/m)
1	5150.00	57.8 PK	74.0	-16.2	1.07 H	117	54.8	3.0
2	5150.00	41.4 AV	54.0	-12.6	1.07 H	117	38.4	3.0
3	*5290.00	95.8 PK			1.07 H	117	92.5	3.3
4	*5290.00	83.6 AV			1.07 H	117	80.3	3.3
5	#10580.00	50.0 PK	74.0	-24.0	1.59 H	307	35.7	14.3
6	#10580.00	38.9 AV	54.0	-15.1	1.59 H	307	24.6	14.3
7	15870.00	51.4 PK	74.0	-22.6	1.41 H	145	36.4	15.0
8	15870.00	40.9 AV	54.0	-13.1	1.41 H	145	25.9	15.0

ANTENNA POLARITY & TEST DISTANCE: VERTICAL AT 3 M

NO.	FREQ. (MHz)	EMISSION LEVEL (dBuV/m)	LIMIT (dBuV/m)	MARGIN (dB)	ANTENNA HEIGHT (m)	TABLE ANGLE (Degree)	RAW VALUE (dBuV)	CORRECTION FACTOR (dB/m)
1	5150.00	73.9 PK	74.0	-0.1	2.64 V	62	70.9	3.0
2	5150.00	47.8 AV	54.0	-6.2	2.64 V	62	44.8	3.0
3	*5290.00	106.9 PK			2.64 V	62	103.6	3.3
4	*5290.00	94.1 AV			2.64 V	62	90.8	3.3
5	#10580.00	49.8 PK	74.0	-24.2	1.00 V	360	35.5	14.3
6	#10580.00	38.7 AV	54.0	-15.3	1.00 V	360	24.4	14.3
7	15870.00	50.0 PK	74.0	-24.0	1.00 V	340	35.0	15.0
8	15870.00	40.0 AV	54.0	-14.0	1.00 V	340	25.0	15.0

Remark:

1. Emission Level(dBuV/m) = Raw Value(dBuV) + Correction Factor(dB/m)
2. Correction Factor(dB/m) = Antenna Factor(dB/m) + Cable Factor(dB)
3. The other emission levels were very low against the limit.
4. Margin value = Emission Level – Limit value
5. " * ": Fundamental frequency.
6. " # ": The radiated frequency is out of the restricted band.

CHANNEL	TX Channel 106	DETECTOR FUNCTION	Peak (PK)
FREQUENCY RANGE	1GHz ~ 40GHz		Average (AV)

ANTENNA POLARITY & TEST DISTANCE: HORIZONTAL AT 3 M

NO.	FREQ. (MHz)	EMISSION LEVEL (dBuV/m)	LIMIT (dBuV/m)	MARGIN (dB)	ANTENNA HEIGHT (m)	TABLE ANGLE (Degree)	RAW VALUE (dBuV)	CORRECTION FACTOR (dB/m)
1	#5466.00	57.9 PK	74.0	-16.1	1.06 H	139	54.2	3.7
2	#5466.00	45.4 AV	54.0	-8.6	1.06 H	139	41.7	3.7
3	*5530.00	96.7 PK			1.06 H	139	92.8	3.9
4	*5530.00	84.9 AV			1.06 H	139	81.0	3.9
5	11060.00	49.2 PK	74.0	-24.8	1.52 H	316	34.1	15.1
6	11060.00	38.3 AV	54.0	-15.7	1.52 H	316	23.2	15.1
7	#16590.00	50.4 PK	74.0	-23.6	1.45 H	131	32.7	17.7
8	#16590.00	40.2 AV	54.0	-13.8	1.45 H	131	22.5	17.7

ANTENNA POLARITY & TEST DISTANCE: VERTICAL AT 3 M

NO.	FREQ. (MHz)	EMISSION LEVEL (dBuV/m)	LIMIT (dBuV/m)	MARGIN (dB)	ANTENNA HEIGHT (m)	TABLE ANGLE (Degree)	RAW VALUE (dBuV)	CORRECTION FACTOR (dB/m)
1	#5466.00	73.6 PK	74.0	-0.4	2.58 V	59	69.9	3.7
2	#5466.00	53.5 AV	54.0	-0.5	2.58 V	59	49.8	3.7
3	*5530.00	107.7 PK			2.58 V	59	103.8	3.9
4	*5530.00	95.7 AV			2.58 V	59	91.8	3.9
5	11060.00	50.4 PK	74.0	-23.6	1.00 V	360	35.3	15.1
6	11060.00	39.2 AV	54.0	-14.8	1.00 V	360	24.1	15.1
7	#16590.00	50.3 PK	74.0	-23.7	1.01 V	348	32.6	17.7
8	#16590.00	40.1 AV	54.0	-13.9	1.01 V	348	22.4	17.7

Remark:

1. Emission Level(dBuV/m) = Raw Value(dBuV) + Correction Factor(dB/m)
2. Correction Factor(dB/m) = Antenna Factor(dB/m) + Cable Factor(dB)
3. The other emission levels were very low against the limit.
4. Margin value = Emission Level – Limit value
5. " * ": Fundamental frequency.
6. " # ": The radiated frequency is out of the restricted band.

CHANNEL	TX Channel 122	DETECTOR FUNCTION	Peak (PK)
FREQUENCY RANGE	1GHz ~ 40GHz		Average (AV)

ANTENNA POLARITY & TEST DISTANCE: HORIZONTAL AT 3 M								
NO.	FREQ. (MHz)	EMISSION LEVEL (dBuV/m)	LIMIT (dBuV/m)	MARGIN (dB)	ANTENNA HEIGHT (m)	TABLE ANGLE (Degree)	RAW VALUE (dBuV)	CORRECTION FACTOR (dB/m)
1	*5610.00	102.4 PK			1.11 H	122	98.5	3.9
2	*5610.00	91.4 AV			1.11 H	122	87.5	3.9
3	#5730.00	57.5 PK	74.0	-16.5	1.11 H	122	53.3	4.2
4	#5730.00	45.0 AV	54.0	-9.0	1.11 H	122	40.8	4.2
5	11220.00	49.0 PK	74.0	-25.0	1.51 H	310	33.8	15.2
6	11220.00	38.3 AV	54.0	-15.7	1.51 H	310	23.1	15.2
7	#16830.00	50.9 PK	74.0	-23.1	1.44 H	144	32.4	18.5
8	#16830.00	40.8 AV	54.0	-13.2	1.44 H	144	22.3	18.5
ANTENNA POLARITY & TEST DISTANCE: VERTICAL AT 3 M								
NO.	FREQ. (MHz)	EMISSION LEVEL (dBuV/m)	LIMIT (dBuV/m)	MARGIN (dB)	ANTENNA HEIGHT (m)	TABLE ANGLE (Degree)	RAW VALUE (dBuV)	CORRECTION FACTOR (dB/m)
1	*5610.00	113.1 PK			2.38 V	60	109.2	3.9
2	*5610.00	102.3 AV			2.38 V	60	98.4	3.9
3	#5730.00	70.1 PK	74.0	-3.9	2.38 V	60	65.9	4.2
4	#5730.00	53.3 AV	54.0	-0.7	2.38 V	60	49.1	4.2
5	11220.00	50.7 PK	74.0	-23.3	1.03 V	355	35.5	15.2
6	11220.00	39.0 AV	54.0	-15.0	1.03 V	355	23.8	15.2
7	#16830.00	49.9 PK	74.0	-24.1	1.02 V	360	31.4	18.5
8	#16830.00	39.8 AV	54.0	-14.2	1.02 V	360	21.3	18.5

Remark:

1. Emission Level(dBuV/m) = Raw Value(dBuV) + Correction Factor(dB/m)
2. Correction Factor(dB/m) = Antenna Factor(dB/m) + Cable Factor(dB)
3. The other emission levels were very low against the limit.
4. Margin value = Emission Level – Limit value
5. " * ": Fundamental frequency.
6. " # ": The radiated frequency is out of the restricted band.

CHANNEL	TX Channel 138	DETECTOR FUNCTION	Peak (PK)
FREQUENCY RANGE	1GHz ~ 40GHz		Average (AV)

ANTENNA POLARITY & TEST DISTANCE: HORIZONTAL AT 3 M								
NO.	FREQ. (MHz)	EMISSION LEVEL (dBuV/m)	LIMIT (dBuV/m)	MARGIN (dB)	ANTENNA HEIGHT (m)	TABLE ANGLE (Degree)	RAW VALUE (dBuV)	CORRECTION FACTOR (dB/m)
1	#5470.00	49.4 PK	74.0	-24.6	1.07 H	137	45.7	3.7
2	#5470.00	39.8 AV	54.0	-14.2	1.07 H	137	36.1	3.7
3	*5690.00	104.4 PK			1.07 H	137	100.2	4.2
4	*5690.00	93.3 AV			1.07 H	137	89.1	4.2
5	#5850.00	49.9 PK	74.0	-24.1	1.07 H	137	45.7	4.2
6	#5850.00	40.2 AV	54.0	-13.8	1.07 H	137	36.0	4.2
7	11380.00	48.4 PK	74.0	-25.6	1.46 H	314	33.0	15.4
8	11380.00	38.0 AV	54.0	-16.0	1.46 H	314	22.6	15.4
9	#17070.00	50.6 PK	74.0	-23.4	1.42 H	143	30.6	20.0
10	#17070.00	40.5 AV	54.0	-13.5	1.42 H	143	20.5	20.0

ANTENNA POLARITY & TEST DISTANCE: VERTICAL AT 3 M								
NO.	FREQ. (MHz)	EMISSION LEVEL (dBuV/m)	LIMIT (dBuV/m)	MARGIN (dB)	ANTENNA HEIGHT (m)	TABLE ANGLE (Degree)	RAW VALUE (dBuV)	CORRECTION FACTOR (dB/m)
1	#5470.00	49.4 PK	74.0	-24.6	1.00 V	360	45.7	3.7
2	#5470.00	39.6 AV	54.0	-14.4	1.00 V	360	35.9	3.7
3	*5690.00	114.2 PK			1.00 V	360	110.0	4.2
4	*5690.00	103.4 AV			1.00 V	360	99.2	4.2
5	#5850.00	49.6 PK	74.0	-24.4	1.00 V	360	45.4	4.2
6	#5850.00	39.9 AV	54.0	-14.1	1.00 V	360	35.7	4.2
7	11380.00	49.9 PK	74.0	-24.1	1.01 V	360	34.5	15.4
8	11380.00	39.1 AV	54.0	-14.9	1.01 V	360	23.7	15.4
9	#17070.00	52.6 PK	74.0	-21.4	1.05 V	360	32.6	20.0
10	#17070.00	41.9 AV	54.0	-12.1	1.05 V	360	21.9	20.0

Remark:

1. Emission Level(dBuV/m) = Raw Value(dBuV) + Correction Factor(dB/m)
2. Correction Factor(dB/m) = Antenna Factor(dB/m) + Cable Factor(dB)
3. The other emission levels were very low against the limit.
4. Margin value = Emission Level – Limit value
5. " * ": Fundamental frequency.
6. " # ": The radiated frequency is out of the restricted band.

Radio 2 - 4TX with Dipole antenna CDD Mode

802.11a

CHANNEL	TX Channel 52	DETECTOR FUNCTION	Peak (PK)
FREQUENCY RANGE	1GHz ~ 40GHz		Average (AV)

ANTENNA POLARITY & TEST DISTANCE: HORIZONTAL AT 3 M								
NO.	FREQ. (MHz)	EMISSION LEVEL (dBuV/m)	LIMIT (dBuV/m)	MARGIN (dB)	ANTENNA HEIGHT (m)	TABLE ANGLE (Degree)	RAW VALUE (dBuV)	CORRECTION FACTOR (dB/m)
1	5100.00	50.8 PK	74.0	-23.2	2.46 H	171	48.0	2.8
2	5100.00	41.8 AV	54.0	-12.2	2.46 H	171	39.0	2.8
3	*5260.00	112.3 PK			2.69 H	181	109.0	3.3
4	*5260.00	103.1 AV			2.69 H	181	99.8	3.3
5	#10520.00	50.5 PK	74.0	-23.5	1.49 H	100	36.4	14.1
6	#10520.00	39.2 AV	54.0	-14.8	1.49 H	100	25.1	14.1
7	15780.00	50.7 PK	74.0	-23.3	2.12 H	318	35.5	15.2
8	15780.00	40.3 AV	54.0	-13.7	2.12 H	318	25.1	15.2

ANTENNA POLARITY & TEST DISTANCE: VERTICAL AT 3 M								
NO.	FREQ. (MHz)	EMISSION LEVEL (dBuV/m)	LIMIT (dBuV/m)	MARGIN (dB)	ANTENNA HEIGHT (m)	TABLE ANGLE (Degree)	RAW VALUE (dBuV)	CORRECTION FACTOR (dB/m)
1	5100.00	48.9 PK	74.0	-25.1	2.58 V	299	46.1	2.8
2	5100.00	38.8 AV	54.0	-15.2	2.58 V	299	36.0	2.8
3	*5260.00	101.9 PK			2.58 V	299	98.6	3.3
4	*5260.00	92.8 AV			2.58 V	299	89.5	3.3
5	#10520.00	50.3 PK	74.0	-23.7	1.21 V	96	36.2	14.1
6	#10520.00	39.1 AV	54.0	-14.9	1.21 V	96	25.0	14.1
7	15780.00	50.7 PK	74.0	-23.3	3.02 V	161	35.5	15.2
8	15780.00	40.5 AV	54.0	-13.5	3.02 V	161	25.3	15.2

Remark:

1. Emission Level(dBuV/m) = Raw Value(dBuV) + Correction Factor(dB/m)
2. Correction Factor(dB/m) = Antenna Factor(dB/m) + Cable Factor(dB)
3. The other emission levels were very low against the limit.
4. Margin value = Emission Level – Limit value
5. " * ": Fundamental frequency.
6. " # ": The radiated frequency is out of the restricted band.

CHANNEL	TX Channel 60	DETECTOR FUNCTION	Peak (PK)
FREQUENCY RANGE	1GHz ~ 40GHz		Average (AV)

ANTENNA POLARITY & TEST DISTANCE: HORIZONTAL AT 3 M								
NO.	FREQ. (MHz)	EMISSION LEVEL (dBuV/m)	LIMIT (dBuV/m)	MARGIN (dB)	ANTENNA HEIGHT (m)	TABLE ANGLE (Degree)	RAW VALUE (dBuV)	CORRECTION FACTOR (dB/m)
1	*5300.00	112.0 PK			3.13 H	183	108.7	3.3
2	*5300.00	102.9 AV			3.13 H	183	99.6	3.3
3	10600.00	50.2 PK	74.0	-23.8	1.41 H	93	35.9	14.3
4	10600.00	39.1 AV	54.0	-14.9	1.41 H	93	24.8	14.3
5	15900.00	51.0 PK	74.0	-23.0	2.08 H	296	35.9	15.1
6	15900.00	40.6 AV	54.0	-13.4	2.08 H	296	25.5	15.1

ANTENNA POLARITY & TEST DISTANCE: VERTICAL AT 3 M								
NO.	FREQ. (MHz)	EMISSION LEVEL (dBuV/m)	LIMIT (dBuV/m)	MARGIN (dB)	ANTENNA HEIGHT (m)	TABLE ANGLE (Degree)	RAW VALUE (dBuV)	CORRECTION FACTOR (dB/m)
1	*5300.00	102.0 PK			2.68 V	289	98.7	3.3
2	*5300.00	93.2 AV			2.68 V	289	89.9	3.3
3	10600.00	50.8 PK	74.0	-23.2	1.23 V	93	36.5	14.3
4	10600.00	39.7 AV	54.0	-14.3	1.23 V	93	25.4	14.3
5	15900.00	50.5 PK	74.0	-23.5	2.99 V	160	35.4	15.1
6	15900.00	40.0 AV	54.0	-14.0	2.99 V	160	24.9	15.1

Remark:

1. Emission Level(dBuV/m) = Raw Value(dBuV) + Correction Factor(dB/m)
2. Correction Factor(dB/m) = Antenna Factor(dB/m) + Cable Factor(dB)
3. The other emission levels were very low against the limit.
4. Margin value = Emission Level – Limit value
5. " * ": Fundamental frequency.
6. " # ": The radiated frequency is out of the restricted band.

CHANNEL	TX Channel 64	DETECTOR FUNCTION	Peak (PK)
FREQUENCY RANGE	1GHz ~ 40GHz		Average (AV)

ANTENNA POLARITY & TEST DISTANCE: HORIZONTAL AT 3 M								
NO.	FREQ. (MHz)	EMISSION LEVEL (dBuV/m)	LIMIT (dBuV/m)	MARGIN (dB)	ANTENNA HEIGHT (m)	TABLE ANGLE (Degree)	RAW VALUE (dBuV)	CORRECTION FACTOR (dB/m)
1	*5320.00	112.0 PK			2.81 H	181	108.5	3.5
2	*5320.00	102.6 AV			2.81 H	181	99.1	3.5
3	5350.00	66.5 PK	74.0	-7.5	2.93 H	248	63.0	3.5
4	5350.00	47.2 AV	54.0	-6.8	2.93 H	248	43.7	3.5
5	10640.00	50.6 PK	74.0	-23.4	1.48 H	78	36.3	14.3
6	10640.00	39.7 AV	54.0	-14.3	1.48 H	78	25.4	14.3
7	15960.00	50.5 PK	74.0	-23.5	2.07 H	295	35.4	15.1
8	15960.00	40.3 AV	54.0	-13.7	2.07 H	295	25.2	15.1
ANTENNA POLARITY & TEST DISTANCE: VERTICAL AT 3 M								
NO.	FREQ. (MHz)	EMISSION LEVEL (dBuV/m)	LIMIT (dBuV/m)	MARGIN (dB)	ANTENNA HEIGHT (m)	TABLE ANGLE (Degree)	RAW VALUE (dBuV)	CORRECTION FACTOR (dB/m)
1	*5320.00	102.4 PK			2.58 V	296	98.9	3.5
2	*5320.00	93.2 AV			2.58 V	296	89.7	3.5
3	5350.00	49.4 PK	74.0	-24.6	2.58 V	296	45.9	3.5
4	5350.00	38.9 AV	54.0	-15.1	2.58 V	296	35.4	3.5
5	10640.00	49.8 PK	74.0	-24.2	1.20 V	104	35.5	14.3
6	10640.00	39.0 AV	54.0	-15.0	1.20 V	104	24.7	14.3
7	15960.00	50.3 PK	74.0	-23.7	2.95 V	158	35.2	15.1
8	15960.00	39.8 AV	54.0	-14.2	2.95 V	158	24.7	15.1

Remark:

1. Emission Level(dBuV/m) = Raw Value(dBuV) + Correction Factor(dB/m)
2. Correction Factor(dB/m) = Antenna Factor(dB/m) + Cable Factor(dB)
3. The other emission levels were very low against the limit.
4. Margin value = Emission Level – Limit value
5. " * ": Fundamental frequency.
6. " # ": The radiated frequency is out of the restricted band.

CHANNEL	TX Channel 100	DETECTOR FUNCTION	Peak (PK)
FREQUENCY RANGE	1GHz ~ 40GHz		Average (AV)

ANTENNA POLARITY & TEST DISTANCE: HORIZONTAL AT 3 M

NO.	FREQ. (MHz)	EMISSION LEVEL (dBuV/m)	LIMIT (dBuV/m)	MARGIN (dB)	ANTENNA HEIGHT (m)	TABLE ANGLE (Degree)	RAW VALUE (dBuV)	CORRECTION FACTOR (dB/m)
1	#5470.00	67.1 PK	74.0	-6.9	2.83 H	182	63.4	3.7
2	#5470.00	47.6 AV	54.0	-6.4	2.83 H	182	43.9	3.7
3	*5500.00	112.2 PK			2.59 H	182	108.4	3.8
4	*5500.00	102.9 AV			2.59 H	182	99.1	3.8
5	11000.00	50.6 PK	74.0	-23.4	1.50 H	91	35.4	15.2
6	11000.00	39.3 AV	54.0	-14.7	1.50 H	91	24.1	15.2
7	#16500.00	51.2 PK	74.0	-22.8	2.10 H	299	33.8	17.4
8	#16500.00	41.1 AV	54.0	-12.9	2.10 H	299	23.7	17.4

ANTENNA POLARITY & TEST DISTANCE: VERTICAL AT 3 M

NO.	FREQ. (MHz)	EMISSION LEVEL (dBuV/m)	LIMIT (dBuV/m)	MARGIN (dB)	ANTENNA HEIGHT (m)	TABLE ANGLE (Degree)	RAW VALUE (dBuV)	CORRECTION FACTOR (dB/m)
1	#5470.00	49.8 PK	74.0	-24.2	2.63 V	313	46.1	3.7
2	#5470.00	39.6 AV	54.0	-14.4	2.63 V	313	35.9	3.7
3	*5500.00	101.9 PK			2.63 V	313	98.1	3.8
4	*5500.00	93.0 AV			2.63 V	313	89.2	3.8
5	11000.00	50.4 PK	74.0	-23.6	1.23 V	84	35.2	15.2
6	11000.00	39.4 AV	54.0	-14.6	1.23 V	84	24.2	15.2
7	#16500.00	50.4 PK	74.0	-23.6	2.95 V	166	33.0	17.4
8	#16500.00	39.9 AV	54.0	-14.1	2.95 V	166	22.5	17.4

Remark:

1. Emission Level(dBuV/m) = Raw Value(dBuV) + Correction Factor(dB/m)
2. Correction Factor(dB/m) = Antenna Factor(dB/m) + Cable Factor(dB)
3. The other emission levels were very low against the limit.
4. Margin value = Emission Level – Limit value
5. " * ": Fundamental frequency.
6. " # ": The radiated frequency is out of the restricted band.

CHANNEL	TX Channel 116	DETECTOR FUNCTION	Peak (PK)
FREQUENCY RANGE	1GHz ~ 40GHz		Average (AV)

ANTENNA POLARITY & TEST DISTANCE: HORIZONTAL AT 3 M								
NO.	FREQ. (MHz)	EMISSION LEVEL (dBuV/m)	LIMIT (dBuV/m)	MARGIN (dB)	ANTENNA HEIGHT (m)	TABLE ANGLE (Degree)	RAW VALUE (dBuV)	CORRECTION FACTOR (dB/m)
1	*5580.00	111.9 PK			2.40 H	180	108.0	3.9
2	*5580.00	102.8 AV			2.40 H	180	98.9	3.9
3	11160.00	50.4 PK	74.0	-23.6	1.41 H	82	35.2	15.2
4	11160.00	39.1 AV	54.0	-14.9	1.41 H	82	23.9	15.2
5	#16740.00	50.8 PK	74.0	-23.2	2.12 H	318	32.5	18.3
6	#16740.00	40.5 AV	54.0	-13.5	2.12 H	318	22.2	18.3

ANTENNA POLARITY & TEST DISTANCE: VERTICAL AT 3 M								
NO.	FREQ. (MHz)	EMISSION LEVEL (dBuV/m)	LIMIT (dBuV/m)	MARGIN (dB)	ANTENNA HEIGHT (m)	TABLE ANGLE (Degree)	RAW VALUE (dBuV)	CORRECTION FACTOR (dB/m)
1	*5580.00	102.7 PK			2.65 V	299	98.8	3.9
2	*5580.00	93.7 AV			2.65 V	299	89.8	3.9
3	11160.00	49.8 PK	74.0	-24.2	1.29 V	75	34.6	15.2
4	11160.00	39.1 AV	54.0	-14.9	1.29 V	75	23.9	15.2
5	#16740.00	50.6 PK	74.0	-23.4	3.04 V	156	32.3	18.3
6	#16740.00	40.5 AV	54.0	-13.5	3.04 V	156	22.2	18.3

Remark:

1. Emission Level(dBuV/m) = Raw Value(dBuV) + Correction Factor(dB/m)
2. Correction Factor(dB/m) = Antenna Factor(dB/m) + Cable Factor(dB)
3. The other emission levels were very low against the limit.
4. Margin value = Emission Level – Limit value
5. " * ": Fundamental frequency.
6. " # ": The radiated frequency is out of the restricted band.

CHANNEL	TX Channel 140	DETECTOR FUNCTION	Peak (PK)
FREQUENCY RANGE	1GHz ~ 40GHz		Average (AV)

ANTENNA POLARITY & TEST DISTANCE: HORIZONTAL AT 3 M								
NO.	FREQ. (MHz)	EMISSION LEVEL (dBuV/m)	LIMIT (dBuV/m)	MARGIN (dB)	ANTENNA HEIGHT (m)	TABLE ANGLE (Degree)	RAW VALUE (dBuV)	CORRECTION FACTOR (dB/m)
1	*5700.00	112.2 PK			2.36 H	273	108.0	4.2
2	*5700.00	103.0 AV			2.36 H	273	98.8	4.2
3	#5725.00	67.4 PK	74.0	-6.6	2.58 H	273	63.2	4.2
4	#5725.00	47.7 AV	54.0	-6.3	2.58 H	273	43.5	4.2
5	11400.00	50.4 PK	74.0	-23.6	1.41 H	91	34.9	15.5
6	11400.00	39.4 AV	54.0	-14.6	1.41 H	91	23.9	15.5
7	#17100.00	51.2 PK	74.0	-22.8	2.14 H	291	31.1	20.1
8	#17100.00	40.8 AV	54.0	-13.2	2.14 H	291	20.7	20.1
ANTENNA POLARITY & TEST DISTANCE: VERTICAL AT 3 M								
NO.	FREQ. (MHz)	EMISSION LEVEL (dBuV/m)	LIMIT (dBuV/m)	MARGIN (dB)	ANTENNA HEIGHT (m)	TABLE ANGLE (Degree)	RAW VALUE (dBuV)	CORRECTION FACTOR (dB/m)
1	*5700.00	102.2 PK			2.68 V	295	98.0	4.2
2	*5700.00	93.2 AV			2.68 V	295	89.0	4.2
3	#5725.00	49.1 PK	74.0	-24.9	2.68 V	295	44.9	4.2
4	#5725.00	39.0 AV	54.0	-15.0	2.68 V	295	34.8	4.2
5	11400.00	50.1 PK	74.0	-23.9	1.27 V	89	34.6	15.5
6	11400.00	39.3 AV	54.0	-14.7	1.27 V	89	23.8	15.5
7	#17100.00	50.4 PK	74.0	-23.6	3.00 V	151	30.3	20.1
8	#17100.00	40.2 AV	54.0	-13.8	3.00 V	151	20.1	20.1

Remark:

1. Emission Level(dBuV/m) = Raw Value(dBuV) + Correction Factor(dB/m)
2. Correction Factor(dB/m) = Antenna Factor(dB/m) + Cable Factor(dB)
3. The other emission levels were very low against the limit.
4. Margin value = Emission Level – Limit value
5. " * ": Fundamental frequency.
6. " # ": The radiated frequency is out of the restricted band.

CHANNEL	TX Channel 144	DETECTOR FUNCTION	Peak (PK)
FREQUENCY RANGE	1GHz ~ 40GHz		Average (AV)

ANTENNA POLARITY & TEST DISTANCE: HORIZONTAL AT 3 M

NO.	FREQ. (MHz)	EMISSION LEVEL (dBuV/m)	LIMIT (dBuV/m)	MARGIN (dB)	ANTENNA HEIGHT (m)	TABLE ANGLE (Degree)	RAW VALUE (dBuV)	CORRECTION FACTOR (dB/m)
1	#5470.00	49.6 PK	74.0	-24.4	2.39 H	276	45.9	3.7
2	#5470.00	39.5 AV	54.0	-14.5	2.39 H	276	35.8	3.7
3	*5720.00	112.3 PK			2.39 H	276	108.1	4.2
4	*5720.00	103.2 AV			2.39 H	276	99.0	4.2
5	#5850.00	48.6 PK	74.0	-25.4	2.39 H	276	44.4	4.2
6	#5850.00	38.7 AV	54.0	-15.3	2.39 H	276	34.5	4.2
7	11440.00	50.6 PK	74.0	-23.4	1.43 H	103	35.3	15.3
8	11440.00	39.6 AV	54.0	-14.4	1.43 H	103	24.3	15.3
9	#17160.00	51.5 PK	74.0	-22.5	2.09 H	295	31.7	19.8
10	#17160.00	41.1 AV	54.0	-12.9	2.09 H	295	21.3	19.8

ANTENNA POLARITY & TEST DISTANCE: VERTICAL AT 3 M

NO.	FREQ. (MHz)	EMISSION LEVEL (dBuV/m)	LIMIT (dBuV/m)	MARGIN (dB)	ANTENNA HEIGHT (m)	TABLE ANGLE (Degree)	RAW VALUE (dBuV)	CORRECTION FACTOR (dB/m)
1	#5470.00	49.0 PK	74.0	-25.0	2.72 V	293	45.3	3.7
2	#5470.00	38.9 AV	54.0	-15.1	2.72 V	293	35.2	3.7
3	*5720.00	101.8 PK			2.72 V	293	97.6	4.2
4	*5720.00	93.0 AV			2.72 V	293	88.8	4.2
5	#5850.00	49.3 PK	74.0	-24.7	2.72 V	293	45.1	4.2
6	#5850.00	39.4 AV	54.0	-14.6	2.72 V	293	35.2	4.2
7	11440.00	49.6 PK	74.0	-24.4	1.29 V	74	34.3	15.3
8	11440.00	38.5 AV	54.0	-15.5	1.29 V	74	23.2	15.3
9	#17160.00	50.4 PK	74.0	-23.6	3.00 V	164	30.6	19.8
10	#17160.00	40.2 AV	54.0	-13.8	3.00 V	164	20.4	19.8

Remark:

1. Emission Level(dBuV/m) = Raw Value(dBuV) + Correction Factor(dB/m)
2. Correction Factor(dB/m) = Antenna Factor(dB/m) + Cable Factor(dB)
3. The other emission levels were very low against the limit.
4. Margin value = Emission Level – Limit value
5. " * ": Fundamental frequency.
6. " # ": The radiated frequency is out of the restricted band.

802.11ac (VHT20)

CHANNEL	TX Channel 52	DETECTOR FUNCTION	Peak (PK)
FREQUENCY RANGE	1GHz ~ 40GHz		Average (AV)

ANTENNA POLARITY & TEST DISTANCE: HORIZONTAL AT 3 M

NO.	FREQ. (MHz)	EMISSION LEVEL (dBuV/m)	LIMIT (dBuV/m)	MARGIN (dB)	ANTENNA HEIGHT (m)	TABLE ANGLE (Degree)	RAW VALUE (dBuV)	CORRECTION FACTOR (dB/m)
1	5150.00	51.3 PK	74.0	-22.7	2.82 H	164	48.3	3.0
2	5150.00	41.9 AV	54.0	-12.1	2.82 H	164	38.9	3.0
3	*5260.00	112.3 PK			2.82 H	164	109.0	3.3
4	*5260.00	102.5 AV			2.82 H	164	99.2	3.3
5	#10520.00	50.5 PK	74.0	-23.5	1.43 H	80	36.4	14.1
6	#10520.00	39.3 AV	54.0	-14.7	1.43 H	80	25.2	14.1
7	15780.00	50.3 PK	74.0	-23.7	2.06 H	294	35.1	15.2
8	15780.00	40.3 AV	54.0	-13.7	2.06 H	294	25.1	15.2

ANTENNA POLARITY & TEST DISTANCE: VERTICAL AT 3 M

NO.	FREQ. (MHz)	EMISSION LEVEL (dBuV/m)	LIMIT (dBuV/m)	MARGIN (dB)	ANTENNA HEIGHT (m)	TABLE ANGLE (Degree)	RAW VALUE (dBuV)	CORRECTION FACTOR (dB/m)
1	5150.00	49.3 PK	74.0	-24.7	2.65 V	303	46.3	3.0
2	5150.00	38.8 AV	54.0	-15.2	2.65 V	303	35.8	3.0
3	*5260.00	101.2 PK			2.65 V	303	97.9	3.3
4	*5260.00	91.4 AV			2.65 V	303	88.1	3.3
5	#10520.00	50.6 PK	74.0	-23.4	1.25 V	102	36.5	14.1
6	#10520.00	39.6 AV	54.0	-14.4	1.25 V	102	25.5	14.1
7	15780.00	50.1 PK	74.0	-23.9	3.03 V	162	34.9	15.2
8	15780.00	39.9 AV	54.0	-14.1	3.03 V	162	24.7	15.2

Remark:

1. Emission Level(dBuV/m) = Raw Value(dBuV) + Correction Factor(dB/m)
2. Correction Factor(dB/m) = Antenna Factor(dB/m) + Cable Factor(dB)
3. The other emission levels were very low against the limit.
4. Margin value = Emission Level – Limit value
5. " * ": Fundamental frequency.
6. " # ": The radiated frequency is out of the restricted band.

CHANNEL	TX Channel 60	DETECTOR FUNCTION	Peak (PK)
FREQUENCY RANGE	1GHz ~ 40GHz		Average (AV)

ANTENNA POLARITY & TEST DISTANCE: HORIZONTAL AT 3 M								
NO.	FREQ. (MHz)	EMISSION LEVEL (dBuV/m)	LIMIT (dBuV/m)	MARGIN (dB)	ANTENNA HEIGHT (m)	TABLE ANGLE (Degree)	RAW VALUE (dBuV)	CORRECTION FACTOR (dB/m)
1	*5300.00	112.5 PK			2.81 H	190	109.2	3.3
2	*5300.00	102.9 AV			2.81 H	190	99.6	3.3
3	10600.00	50.6 PK	74.0	-23.4	1.44 H	99	36.3	14.3
4	10600.00	39.6 AV	54.0	-14.4	1.44 H	99	25.3	14.3
5	15900.00	50.7 PK	74.0	-23.3	2.10 H	296	35.6	15.1
6	15900.00	40.5 AV	54.0	-13.5	2.10 H	296	25.4	15.1
ANTENNA POLARITY & TEST DISTANCE: VERTICAL AT 3 M								
NO.	FREQ. (MHz)	EMISSION LEVEL (dBuV/m)	LIMIT (dBuV/m)	MARGIN (dB)	ANTENNA HEIGHT (m)	TABLE ANGLE (Degree)	RAW VALUE (dBuV)	CORRECTION FACTOR (dB/m)
1	*5300.00	100.9 PK			2.63 V	293	97.6	3.3
2	*5300.00	91.2 AV			2.63 V	293	87.9	3.3
3	10600.00	50.3 PK	74.0	-23.7	1.22 V	77	36.0	14.3
4	10600.00	39.5 AV	54.0	-14.5	1.22 V	77	25.2	14.3
5	15900.00	50.5 PK	74.0	-23.5	3.01 V	143	35.4	15.1
6	15900.00	40.2 AV	54.0	-13.8	3.01 V	143	25.1	15.1

Remark:

1. Emission Level(dBuV/m) = Raw Value(dBuV) + Correction Factor(dB/m)
2. Correction Factor(dB/m) = Antenna Factor(dB/m) + Cable Factor(dB)
3. The other emission levels were very low against the limit.
4. Margin value = Emission Level – Limit value
5. " * ": Fundamental frequency.
6. " # ": The radiated frequency is out of the restricted band.

CHANNEL	TX Channel 64	DETECTOR FUNCTION	Peak (PK)
FREQUENCY RANGE	1GHz ~ 40GHz		Average (AV)

ANTENNA POLARITY & TEST DISTANCE: HORIZONTAL AT 3 M

NO.	FREQ. (MHz)	EMISSION LEVEL (dBuV/m)	LIMIT (dBuV/m)	MARGIN (dB)	ANTENNA HEIGHT (m)	TABLE ANGLE (Degree)	RAW VALUE (dBuV)	CORRECTION FACTOR (dB/m)
1	*5320.00	112.6 PK			2.84 H	175	109.1	3.5
2	*5320.00	103.0 AV			2.84 H	175	99.5	3.5
3	5350.00	66.7 PK	74.0	-7.3	2.84 H	175	63.2	3.5
4	5350.00	47.3 AV	54.0	-6.7	2.84 H	175	43.8	3.5
5	10640.00	50.7 PK	74.0	-23.3	1.52 H	103	36.4	14.3
6	10640.00	39.5 AV	54.0	-14.5	1.52 H	103	25.2	14.3
7	15960.00	51.5 PK	74.0	-22.5	2.16 H	313	36.4	15.1
8	15960.00	41.2 AV	54.0	-12.8	2.16 H	313	26.1	15.1

ANTENNA POLARITY & TEST DISTANCE: VERTICAL AT 3 M

NO.	FREQ. (MHz)	EMISSION LEVEL (dBuV/m)	LIMIT (dBuV/m)	MARGIN (dB)	ANTENNA HEIGHT (m)	TABLE ANGLE (Degree)	RAW VALUE (dBuV)	CORRECTION FACTOR (dB/m)
1	*5320.00	101.6 PK			2.69 V	292	98.1	3.5
2	*5320.00	91.6 AV			2.69 V	292	88.1	3.5
3	5350.00	49.9 PK	74.0	-24.1	2.69 V	292	46.4	3.5
4	5350.00	39.5 AV	54.0	-14.5	2.69 V	292	36.0	3.5
5	10640.00	50.6 PK	74.0	-23.4	1.30 V	101	36.3	14.3
6	10640.00	39.4 AV	54.0	-14.6	1.30 V	101	25.1	14.3
7	15960.00	50.9 PK	74.0	-23.1	2.94 V	166	35.8	15.1
8	15960.00	40.5 AV	54.0	-13.5	2.94 V	166	25.4	15.1

Remark:

1. Emission Level(dBuV/m) = Raw Value(dBuV) + Correction Factor(dB/m)
2. Correction Factor(dB/m) = Antenna Factor(dB/m) + Cable Factor(dB)
3. The other emission levels were very low against the limit.
4. Margin value = Emission Level – Limit value
5. " * ": Fundamental frequency.
6. " # ": The radiated frequency is out of the restricted band.

CHANNEL	TX Channel 100	DETECTOR FUNCTION	Peak (PK)
FREQUENCY RANGE	1GHz ~ 40GHz		Average (AV)

ANTENNA POLARITY & TEST DISTANCE: HORIZONTAL AT 3 M								
NO.	FREQ. (MHz)	EMISSION LEVEL (dBuV/m)	LIMIT (dBuV/m)	MARGIN (dB)	ANTENNA HEIGHT (m)	TABLE ANGLE (Degree)	RAW VALUE (dBuV)	CORRECTION FACTOR (dB/m)
1	#5470.00	66.8 PK	74.0	-7.2	2.77 H	189	63.1	3.7
2	#5470.00	47.6 AV	54.0	-6.4	2.77 H	189	43.9	3.7
3	*5500.00	112.1 PK			2.77 H	189	108.3	3.8
4	*5500.00	102.4 AV			2.77 H	189	98.6	3.8
5	11000.00	50.8 PK	74.0	-23.2	1.50 H	86	35.6	15.2
6	11000.00	39.4 AV	54.0	-14.6	1.50 H	86	24.2	15.2
7	#16500.00	50.8 PK	74.0	-23.2	2.09 H	311	33.4	17.4
8	#16500.00	40.6 AV	54.0	-13.4	2.09 H	311	23.2	17.4
ANTENNA POLARITY & TEST DISTANCE: VERTICAL AT 3 M								
NO.	FREQ. (MHz)	EMISSION LEVEL (dBuV/m)	LIMIT (dBuV/m)	MARGIN (dB)	ANTENNA HEIGHT (m)	TABLE ANGLE (Degree)	RAW VALUE (dBuV)	CORRECTION FACTOR (dB/m)
1	#5470.00	49.5 PK	74.0	-24.5	2.68 V	312	45.8	3.7
2	#5470.00	39.4 AV	54.0	-14.6	2.68 V	312	35.7	3.7
3	*5500.00	101.8 PK			2.68 V	312	98.0	3.8
4	*5500.00	91.9 AV			2.68 V	312	88.1	3.8
5	11000.00	50.3 PK	74.0	-23.7	1.25 V	94	35.1	15.2
6	11000.00	39.4 AV	54.0	-14.6	1.25 V	94	24.2	15.2
7	#16500.00	50.7 PK	74.0	-23.3	3.01 V	160	33.3	17.4
8	#16500.00	40.2 AV	54.0	-13.8	3.01 V	160	22.8	17.4

Remark:

1. Emission Level(dBuV/m) = Raw Value(dBuV) + Correction Factor(dB/m)
2. Correction Factor(dB/m) = Antenna Factor(dB/m) + Cable Factor(dB)
3. The other emission levels were very low against the limit.
4. Margin value = Emission Level – Limit value
5. " * ": Fundamental frequency.
6. " # ": The radiated frequency is out of the restricted band.

CHANNEL	TX Channel 116	DETECTOR FUNCTION	Peak (PK)
FREQUENCY RANGE	1GHz ~ 40GHz		Average (AV)

ANTENNA POLARITY & TEST DISTANCE: HORIZONTAL AT 3 M								
NO.	FREQ. (MHz)	EMISSION LEVEL (dBuV/m)	LIMIT (dBuV/m)	MARGIN (dB)	ANTENNA HEIGHT (m)	TABLE ANGLE (Degree)	RAW VALUE (dBuV)	CORRECTION FACTOR (dB/m)
1	*5580.00	112.3 PK			2.76 H	179	108.4	3.9
2	*5580.00	102.4 AV			2.76 H	179	98.5	3.9
3	11160.00	50.9 PK	74.0	-23.1	1.46 H	83	35.7	15.2
4	11160.00	39.8 AV	54.0	-14.2	1.46 H	83	24.6	15.2
5	#16740.00	50.6 PK	74.0	-23.4	2.16 H	318	32.3	18.3
6	#16740.00	40.4 AV	54.0	-13.6	2.16 H	318	22.1	18.3
ANTENNA POLARITY & TEST DISTANCE: VERTICAL AT 3 M								
NO.	FREQ. (MHz)	EMISSION LEVEL (dBuV/m)	LIMIT (dBuV/m)	MARGIN (dB)	ANTENNA HEIGHT (m)	TABLE ANGLE (Degree)	RAW VALUE (dBuV)	CORRECTION FACTOR (dB/m)
1	*5580.00	101.4 PK			2.70 V	315	97.5	3.9
2	*5580.00	91.5 AV			2.70 V	315	87.6	3.9
3	11160.00	50.1 PK	74.0	-23.9	1.20 V	75	34.9	15.2
4	11160.00	39.1 AV	54.0	-14.9	1.20 V	75	23.9	15.2
5	#16740.00	50.5 PK	74.0	-23.5	3.01 V	152	32.2	18.3
6	#16740.00	40.1 AV	54.0	-13.9	3.01 V	152	21.8	18.3

Remark:

1. Emission Level(dBuV/m) = Raw Value(dBuV) + Correction Factor(dB/m)
2. Correction Factor(dB/m) = Antenna Factor(dB/m) + Cable Factor(dB)
3. The other emission levels were very low against the limit.
4. Margin value = Emission Level – Limit value
5. " * ": Fundamental frequency.
6. " # ": The radiated frequency is out of the restricted band.

CHANNEL	TX Channel 140	DETECTOR FUNCTION	Peak (PK)
FREQUENCY RANGE	1GHz ~ 40GHz		Average (AV)

ANTENNA POLARITY & TEST DISTANCE: HORIZONTAL AT 3 M								
NO.	FREQ. (MHz)	EMISSION LEVEL (dBuV/m)	LIMIT (dBuV/m)	MARGIN (dB)	ANTENNA HEIGHT (m)	TABLE ANGLE (Degree)	RAW VALUE (dBuV)	CORRECTION FACTOR (dB/m)
1	*5700.00	111.7 PK			2.82 H	184	107.5	4.2
2	*5700.00	102.2 AV			2.82 H	184	98.0	4.2
3	#5725.00	67.1 PK	74.0	-6.9	2.82 H	184	62.9	4.2
4	#5725.00	47.8 AV	54.0	-6.2	2.82 H	184	43.6	4.2
5	11400.00	51.1 PK	74.0	-22.9	1.50 H	78	35.6	15.5
6	11400.00	39.8 AV	54.0	-14.2	1.50 H	78	24.3	15.5
7	#17100.00	51.0 PK	74.0	-23.0	2.10 H	315	30.9	20.1
8	#17100.00	41.0 AV	54.0	-13.0	2.10 H	315	20.9	20.1
ANTENNA POLARITY & TEST DISTANCE: VERTICAL AT 3 M								
NO.	FREQ. (MHz)	EMISSION LEVEL (dBuV/m)	LIMIT (dBuV/m)	MARGIN (dB)	ANTENNA HEIGHT (m)	TABLE ANGLE (Degree)	RAW VALUE (dBuV)	CORRECTION FACTOR (dB/m)
1	*5700.00	101.2 PK			2.65 V	295	97.0	4.2
2	*5700.00	91.5 AV			2.65 V	295	87.3	4.2
3	#5725.00	49.4 PK	74.0	-24.6	2.65 V	295	45.2	4.2
4	#5725.00	38.9 AV	54.0	-15.1	2.65 V	295	34.7	4.2
5	11400.00	50.5 PK	74.0	-23.5	1.31 V	91	35.0	15.5
6	11400.00	39.8 AV	54.0	-14.2	1.31 V	91	24.3	15.5
7	#17100.00	50.3 PK	74.0	-23.7	2.96 V	143	30.2	20.1
8	#17100.00	40.0 AV	54.0	-14.0	2.96 V	143	19.9	20.1

Remark:

1. Emission Level(dBuV/m) = Raw Value(dBuV) + Correction Factor(dB/m)
2. Correction Factor(dB/m) = Antenna Factor(dB/m) + Cable Factor(dB)
3. The other emission levels were very low against the limit.
4. Margin value = Emission Level – Limit value
5. " * ": Fundamental frequency.
6. " # ": The radiated frequency is out of the restricted band.

CHANNEL	TX Channel 144	DETECTOR FUNCTION	Peak (PK)
FREQUENCY RANGE	1GHz ~ 40GHz		Average (AV)

ANTENNA POLARITY & TEST DISTANCE: HORIZONTAL AT 3 M								
NO.	FREQ. (MHz)	EMISSION LEVEL (dBuV/m)	LIMIT (dBuV/m)	MARGIN (dB)	ANTENNA HEIGHT (m)	TABLE ANGLE (Degree)	RAW VALUE (dBuV)	CORRECTION FACTOR (dB/m)
1	#5470.00	48.4 PK	74.0	-25.6	2.80 H	184	44.7	3.7
2	#5470.00	38.2 AV	54.0	-15.8	2.80 H	184	34.5	3.7
3	*5720.00	111.4 PK			2.80 H	184	107.2	4.2
4	*5720.00	102.2 AV			2.80 H	184	98.0	4.2
5	#5850.00	48.7 PK	74.0	-25.3	2.80 H	184	44.5	4.2
6	#5850.00	38.6 AV	54.0	-15.4	2.80 H	184	34.4	4.2
7	11440.00	50.9 PK	74.0	-23.1	1.48 H	95	35.6	15.3
8	11440.00	39.6 AV	54.0	-14.4	1.48 H	95	24.3	15.3
9	#17160.00	51.8 PK	74.0	-22.2	2.09 H	309	32.0	19.8
10	#17160.00	41.5 AV	54.0	-12.5	2.09 H	309	21.7	19.8

ANTENNA POLARITY & TEST DISTANCE: VERTICAL AT 3 M								
NO.	FREQ. (MHz)	EMISSION LEVEL (dBuV/m)	LIMIT (dBuV/m)	MARGIN (dB)	ANTENNA HEIGHT (m)	TABLE ANGLE (Degree)	RAW VALUE (dBuV)	CORRECTION FACTOR (dB/m)
1	#5470.00	48.8 PK	74.0	-25.2	2.68 V	302	45.1	3.7
2	#5470.00	38.5 AV	54.0	-15.5	2.68 V	302	34.8	3.7
3	*5720.00	100.5 PK			2.68 V	302	96.3	4.2
4	*5720.00	91.0 AV			2.68 V	302	86.8	4.2
5	#5850.00	49.2 PK	74.0	-24.8	2.68 V	302	45.0	4.2
6	#5850.00	38.8 AV	54.0	-15.2	2.68 V	302	34.6	4.2
7	11440.00	50.2 PK	74.0	-23.8	1.31 V	96	34.9	15.3
8	11440.00	38.8 AV	54.0	-15.2	1.31 V	96	23.5	15.3
9	#17160.00	50.0 PK	74.0	-24.0	2.99 V	168	30.2	19.8
10	#17160.00	40.3 AV	54.0	-13.7	2.99 V	168	20.5	19.8

Remark:

1. Emission Level(dBuV/m) = Raw Value(dBuV) + Correction Factor(dB/m)
2. Correction Factor(dB/m) = Antenna Factor(dB/m) + Cable Factor(dB)
3. The other emission levels were very low against the limit.
4. Margin value = Emission Level – Limit value
5. " * ": Fundamental frequency.
6. " # ": The radiated frequency is out of the restricted band.

802.11ac (VHT40)

CHANNEL	TX Channel 54	DETECTOR FUNCTION	Peak (PK)
FREQUENCY RANGE	1GHz ~ 40GHz		Average (AV)

ANTENNA POLARITY & TEST DISTANCE: HORIZONTAL AT 3 M

NO.	FREQ. (MHz)	EMISSION LEVEL (dBuV/m)	LIMIT (dBuV/m)	MARGIN (dB)	ANTENNA HEIGHT (m)	TABLE ANGLE (Degree)	RAW VALUE (dBuV)	CORRECTION FACTOR (dB/m)
1	5150.00	51.7 PK	74.0	-22.3	2.76 H	185	48.7	3.0
2	5150.00	45.1 AV	54.0	-8.9	2.76 H	185	42.1	3.0
3	*5270.00	109.8 PK			2.76 H	185	106.5	3.3
4	*5270.00	100.6 AV			2.76 H	185	97.3	3.3
5	#10540.00	50.1 PK	74.0	-23.9	1.40 H	101	35.9	14.2
6	#10540.00	39.1 AV	54.0	-14.9	1.40 H	101	24.9	14.2
7	15810.00	51.5 PK	74.0	-22.5	2.08 H	315	36.5	15.0
8	15810.00	41.3 AV	54.0	-12.7	2.08 H	315	26.3	15.0

ANTENNA POLARITY & TEST DISTANCE: VERTICAL AT 3 M

NO.	FREQ. (MHz)	EMISSION LEVEL (dBuV/m)	LIMIT (dBuV/m)	MARGIN (dB)	ANTENNA HEIGHT (m)	TABLE ANGLE (Degree)	RAW VALUE (dBuV)	CORRECTION FACTOR (dB/m)
1	5150.00	49.3 PK	74.0	-24.7	2.61 V	293	46.3	3.0
2	5150.00	39.0 AV	54.0	-15.0	2.61 V	293	36.0	3.0
3	*5270.00	98.7 PK			2.61 V	293	95.4	3.3
4	*5270.00	89.9 AV			2.61 V	293	86.6	3.3
5	#10540.00	50.5 PK	74.0	-23.5	1.30 V	84	36.3	14.2
6	#10540.00	39.3 AV	54.0	-14.7	1.30 V	84	25.1	14.2
7	15810.00	51.0 PK	74.0	-23.0	3.01 V	144	36.0	15.0
8	15810.00	40.8 AV	54.0	-13.2	3.01 V	144	25.8	15.0

Remark:

1. Emission Level(dBuV/m) = Raw Value(dBuV) + Correction Factor(dB/m)
2. Correction Factor(dB/m) = Antenna Factor(dB/m) + Cable Factor(dB)
3. The other emission levels were very low against the limit.
4. Margin value = Emission Level – Limit value
5. " * ": Fundamental frequency.
6. " # ": The radiated frequency is out of the restricted band.

CHANNEL	TX Channel 62	DETECTOR FUNCTION	Peak (PK)
FREQUENCY RANGE	1GHz ~ 40GHz		Average (AV)

ANTENNA POLARITY & TEST DISTANCE: HORIZONTAL AT 3 M								
NO.	FREQ. (MHz)	EMISSION LEVEL (dBuV/m)	LIMIT (dBuV/m)	MARGIN (dB)	ANTENNA HEIGHT (m)	TABLE ANGLE (Degree)	RAW VALUE (dBuV)	CORRECTION FACTOR (dB/m)
1	*5310.00	112.2 PK			2.80 H	171	108.8	3.4
2	*5310.00	102.5 AV			2.80 H	171	99.1	3.4
3	5350.00	73.2 PK	74.0	-0.8	2.80 H	171	69.7	3.5
4	5350.00	53.9 AV	54.0	-0.1	2.80 H	171	50.4	3.5
5	10620.00	50.9 PK	74.0	-23.1	1.48 H	75	36.6	14.3
6	10620.00	39.8 AV	54.0	-14.2	1.48 H	75	25.5	14.3
7	15930.00	50.6 PK	74.0	-23.4	2.06 H	321	35.5	15.1
8	15930.00	40.4 AV	54.0	-13.6	2.06 H	321	25.3	15.1
ANTENNA POLARITY & TEST DISTANCE: VERTICAL AT 3 M								
NO.	FREQ. (MHz)	EMISSION LEVEL (dBuV/m)	LIMIT (dBuV/m)	MARGIN (dB)	ANTENNA HEIGHT (m)	TABLE ANGLE (Degree)	RAW VALUE (dBuV)	CORRECTION FACTOR (dB/m)
1	*5310.00	101.6 PK			2.62 V	297	98.2	3.4
2	*5310.00	91.4 AV			2.62 V	297	88.0	3.4
3	5350.00	57.6 PK	74.0	-16.4	2.62 V	297	54.1	3.5
4	5350.00	45.3 AV	54.0	-8.7	2.62 V	297	41.8	3.5
5	10620.00	50.4 PK	74.0	-23.6	1.23 V	97	36.1	14.3
6	10620.00	39.4 AV	54.0	-14.6	1.23 V	97	25.1	14.3
7	15930.00	50.8 PK	74.0	-23.2	3.01 V	150	35.7	15.1
8	15930.00	40.5 AV	54.0	-13.5	3.01 V	150	25.4	15.1

Remark:

1. Emission Level(dBuV/m) = Raw Value(dBuV) + Correction Factor(dB/m)
2. Correction Factor(dB/m) = Antenna Factor(dB/m) + Cable Factor(dB)
3. The other emission levels were very low against the limit.
4. Margin value = Emission Level – Limit value
5. " * ": Fundamental frequency.
6. " # ": The radiated frequency is out of the restricted band.

CHANNEL	TX Channel 102	DETECTOR FUNCTION	Peak (PK)
FREQUENCY RANGE	1GHz ~ 40GHz		Average (AV)

ANTENNA POLARITY & TEST DISTANCE: HORIZONTAL AT 3 M

NO.	FREQ. (MHz)	EMISSION LEVEL (dBuV/m)	LIMIT (dBuV/m)	MARGIN (dB)	ANTENNA HEIGHT (m)	TABLE ANGLE (Degree)	RAW VALUE (dBuV)	CORRECTION FACTOR (dB/m)
1	#5466.00	67.6 PK	74.0	-6.4	2.80 H	193	63.9	3.7
2	#5466.00	53.1 AV	54.0	-0.9	2.80 H	193	49.4	3.7
3	*5510.00	109.6 PK			2.80 H	193	105.8	3.8
4	*5510.00	99.8 AV			2.80 H	193	96.0	3.8
5	11020.00	50.8 PK	74.0	-23.2	1.49 H	87	35.7	15.1
6	11020.00	39.5 AV	54.0	-14.5	1.49 H	87	24.4	15.1
7	#16530.00	51.1 PK	74.0	-22.9	2.08 H	307	33.6	17.5
8	#16530.00	40.8 AV	54.0	-13.2	2.08 H	307	23.3	17.5

ANTENNA POLARITY & TEST DISTANCE: VERTICAL AT 3 M

NO.	FREQ. (MHz)	EMISSION LEVEL (dBuV/m)	LIMIT (dBuV/m)	MARGIN (dB)	ANTENNA HEIGHT (m)	TABLE ANGLE (Degree)	RAW VALUE (dBuV)	CORRECTION FACTOR (dB/m)
1	#5466.00	58.2 PK	74.0	-15.8	2.64 V	317	54.5	3.7
2	#5466.00	45.7 AV	54.0	-8.3	2.64 V	317	42.0	3.7
3	*5510.00	98.8 PK			2.64 V	317	95.0	3.8
4	*5510.00	89.7 AV			2.64 V	317	85.9	3.8
5	11020.00	50.2 PK	74.0	-23.8	1.30 V	87	35.1	15.1
6	11020.00	39.1 AV	54.0	-14.9	1.30 V	87	24.0	15.1
7	#16530.00	51.5 PK	74.0	-22.5	3.04 V	141	34.0	17.5
8	#16530.00	41.1 AV	54.0	-12.9	3.04 V	141	23.6	17.5

Remark:

1. Emission Level(dBuV/m) = Raw Value(dBuV) + Correction Factor(dB/m)
2. Correction Factor(dB/m) = Antenna Factor(dB/m) + Cable Factor(dB)
3. The other emission levels were very low against the limit.
4. Margin value = Emission Level – Limit value
5. " * ": Fundamental frequency.
6. " # ": The radiated frequency is out of the restricted band.

CHANNEL	TX Channel 110	DETECTOR FUNCTION	Peak (PK)
FREQUENCY RANGE	1GHz ~ 40GHz		Average (AV)

ANTENNA POLARITY & TEST DISTANCE: HORIZONTAL AT 3 M								
NO.	FREQ. (MHz)	EMISSION LEVEL (dBuV/m)	LIMIT (dBuV/m)	MARGIN (dB)	ANTENNA HEIGHT (m)	TABLE ANGLE (Degree)	RAW VALUE (dBuV)	CORRECTION FACTOR (dB/m)
1	*5550.00	109.6 PK			2.74 H	174	105.7	3.9
2	*5550.00	100.4 AV			2.74 H	174	96.5	3.9
3	11100.00	50.8 PK	74.0	-23.2	1.47 H	99	35.7	15.1
4	11100.00	39.7 AV	54.0	-14.3	1.47 H	99	24.6	15.1
5	#16650.00	51.5 PK	74.0	-22.5	2.07 H	301	33.5	18.0
6	#16650.00	41.1 AV	54.0	-12.9	2.07 H	301	23.1	18.0
ANTENNA POLARITY & TEST DISTANCE: VERTICAL AT 3 M								
NO.	FREQ. (MHz)	EMISSION LEVEL (dBuV/m)	LIMIT (dBuV/m)	MARGIN (dB)	ANTENNA HEIGHT (m)	TABLE ANGLE (Degree)	RAW VALUE (dBuV)	CORRECTION FACTOR (dB/m)
1	*5550.00	99.1 PK			2.64 V	300	95.2	3.9
2	*5550.00	89.7 AV			2.64 V	300	85.8	3.9
3	11100.00	50.6 PK	74.0	-23.4	1.21 V	89	35.5	15.1
4	11100.00	39.6 AV	54.0	-14.4	1.21 V	89	24.5	15.1
5	#16650.00	51.3 PK	74.0	-22.7	2.98 V	139	33.3	18.0
6	#16650.00	41.3 AV	54.0	-12.7	2.98 V	139	23.3	18.0

Remark:

1. Emission Level(dBuV/m) = Raw Value(dBuV) + Correction Factor(dB/m)
2. Correction Factor(dB/m) = Antenna Factor(dB/m) + Cable Factor(dB)
3. The other emission levels were very low against the limit.
4. Margin value = Emission Level – Limit value
5. " * ": Fundamental frequency.
6. " # ": The radiated frequency is out of the restricted band.

CHANNEL	TX Channel 134	DETECTOR FUNCTION	Peak (PK)
FREQUENCY RANGE	1GHz ~ 40GHz		Average (AV)

ANTENNA POLARITY & TEST DISTANCE: HORIZONTAL AT 3 M								
NO.	FREQ. (MHz)	EMISSION LEVEL (dBuV/m)	LIMIT (dBuV/m)	MARGIN (dB)	ANTENNA HEIGHT (m)	TABLE ANGLE (Degree)	RAW VALUE (dBuV)	CORRECTION FACTOR (dB/m)
1	*5670.00	109.7 PK			2.85 H	174	105.7	4.0
2	*5670.00	100.6 AV			2.85 H	174	96.6	4.0
3	#5725.00	69.3 PK	74.0	-4.7	2.85 H	174	65.1	4.2
4	#5725.00	50.6 AV	54.0	-3.4	2.85 H	174	46.4	4.2
5	11340.00	50.4 PK	74.0	-23.6	1.45 H	86	35.1	15.3
6	11340.00	39.1 AV	54.0	-14.9	1.45 H	86	23.8	15.3
7	#17010.00	51.1 PK	74.0	-22.9	2.16 H	304	31.2	19.9
8	#17010.00	41.2 AV	54.0	-12.8	2.16 H	304	21.3	19.9
ANTENNA POLARITY & TEST DISTANCE: VERTICAL AT 3 M								
NO.	FREQ. (MHz)	EMISSION LEVEL (dBuV/m)	LIMIT (dBuV/m)	MARGIN (dB)	ANTENNA HEIGHT (m)	TABLE ANGLE (Degree)	RAW VALUE (dBuV)	CORRECTION FACTOR (dB/m)
1	*5670.00	99.0 PK			2.66 V	290	95.0	4.0
2	*5670.00	89.8 AV			2.66 V	290	85.8	4.0
3	#5725.00	58.1 PK	74.0	-15.9	2.66 V	290	53.9	4.2
4	#5725.00	45.4 AV	54.0	-8.6	2.66 V	290	41.2	4.2
5	11340.00	50.0 PK	74.0	-24.0	1.27 V	85	34.7	15.3
6	11340.00	38.9 AV	54.0	-15.1	1.27 V	85	23.6	15.3
7	#17010.00	51.0 PK	74.0	-23.0	2.96 V	164	31.1	19.9
8	#17010.00	41.1 AV	54.0	-12.9	2.96 V	164	21.2	19.9

Remark:

1. Emission Level(dBuV/m) = Raw Value(dBuV) + Correction Factor(dB/m)
2. Correction Factor(dB/m) = Antenna Factor(dB/m) + Cable Factor(dB)
3. The other emission levels were very low against the limit.
4. Margin value = Emission Level – Limit value
5. " * ": Fundamental frequency.
6. " # ": The radiated frequency is out of the restricted band.

CHANNEL	TX Channel 142	DETECTOR FUNCTION	Peak (PK)
FREQUENCY RANGE	1GHz ~ 40GHz		Average (AV)

ANTENNA POLARITY & TEST DISTANCE: HORIZONTAL AT 3 M								
NO.	FREQ. (MHz)	EMISSION LEVEL (dBuV/m)	LIMIT (dBuV/m)	MARGIN (dB)	ANTENNA HEIGHT (m)	TABLE ANGLE (Degree)	RAW VALUE (dBuV)	CORRECTION FACTOR (dB/m)
1	#5470.00	58.1 PK	74.0	-15.9	2.85 H	167	54.4	3.7
2	#5470.00	45.0 AV	54.0	-9.0	2.85 H	167	41.3	3.7
3	*5710.00	109.4 PK			2.85 H	167	105.2	4.2
4	*5710.00	100.2 AV			2.85 H	167	96.0	4.2
5	#5850.00	57.5 PK	74.0	-16.5	2.85 H	167	53.3	4.2
6	#5850.00	45.0 AV	54.0	-9.0	2.85 H	167	40.8	4.2
7	11420.00	50.2 PK	74.0	-23.8	1.52 H	96	34.8	15.4
8	11420.00	39.4 AV	54.0	-14.6	1.52 H	96	24.0	15.4
9	#17130.00	51.4 PK	74.0	-22.6	2.01 H	290	31.4	20.0
10	#17130.00	41.0 AV	54.0	-13.0	2.01 H	290	21.0	20.0

ANTENNA POLARITY & TEST DISTANCE: VERTICAL AT 3 M								
NO.	FREQ. (MHz)	EMISSION LEVEL (dBuV/m)	LIMIT (dBuV/m)	MARGIN (dB)	ANTENNA HEIGHT (m)	TABLE ANGLE (Degree)	RAW VALUE (dBuV)	CORRECTION FACTOR (dB/m)
1	#5470.00	57.9 PK	74.0	-16.1	2.68 V	287	54.2	3.7
2	#5470.00	44.9 AV	54.0	-9.1	2.68 V	287	41.2	3.7
3	*5710.00	98.9 PK			2.68 V	287	94.7	4.2
4	*5710.00	89.8 AV			2.68 V	287	85.6	4.2
5	#5850.00	58.1 PK	74.0	-15.9	2.68 V	287	53.9	4.2
6	#5850.00	45.4 AV	54.0	-8.6	2.68 V	287	41.2	4.2
7	11420.00	50.5 PK	74.0	-23.5	1.25 V	92	35.1	15.4
8	11420.00	39.2 AV	54.0	-14.8	1.25 V	92	23.8	15.4
9	#17130.00	50.7 PK	74.0	-23.3	2.94 V	171	30.7	20.0
10	#17130.00	40.5 AV	54.0	-13.5	2.94 V	171	20.5	20.0

Remark:

1. Emission Level(dBuV/m) = Raw Value(dBuV) + Correction Factor(dB/m)
2. Correction Factor(dB/m) = Antenna Factor(dB/m) + Cable Factor(dB)
3. The other emission levels were very low against the limit.
4. Margin value = Emission Level – Limit value
5. " * ": Fundamental frequency.
6. " # ": The radiated frequency is out of the restricted band.

802.11ac (VHT80)

CHANNEL	TX Channel 58	DETECTOR FUNCTION	Peak (PK) Average (AV)
FREQUENCY RANGE	1GHz ~ 40GHz		

ANTENNA POLARITY & TEST DISTANCE: HORIZONTAL AT 3 M

NO.	FREQ. (MHz)	EMISSION LEVEL (dBuV/m)	LIMIT (dBuV/m)	MARGIN (dB)	ANTENNA HEIGHT (m)	TABLE ANGLE (Degree)	RAW VALUE (dBuV)	CORRECTION FACTOR (dB/m)
1	5150.00	50.1 PK	74.0	-23.9	2.83 H	191	47.1	3.0
2	5150.00	39.6 AV	54.0	-14.4	2.83 H	191	36.6	3.0
3	*5290.00	106.4 PK			2.83 H	191	103.1	3.3
4	*5290.00	93.4 AV			2.83 H	191	90.1	3.3
5	5350.00	73.7 PK	74.0	-0.3	2.83 H	191	70.2	3.5
6	5350.00	47.6 AV	54.0	-6.4	2.83 H	191	44.1	3.5
7	#10580.00	50.9 PK	74.0	-23.1	1.40 H	94	36.6	14.3
8	#10580.00	39.6 AV	54.0	-14.4	1.40 H	94	25.3	14.3
9	15870.00	50.5 PK	74.0	-23.5	2.08 H	304	35.5	15.0
10	15870.00	40.6 AV	54.0	-13.4	2.08 H	304	25.6	15.0

ANTENNA POLARITY & TEST DISTANCE: VERTICAL AT 3 M

NO.	FREQ. (MHz)	EMISSION LEVEL (dBuV/m)	LIMIT (dBuV/m)	MARGIN (dB)	ANTENNA HEIGHT (m)	TABLE ANGLE (Degree)	RAW VALUE (dBuV)	CORRECTION FACTOR (dB/m)
1	5150.00	49.0 PK	74.0	-25.0	2.63 V	316	46.0	3.0
2	5150.00	38.7 AV	54.0	-15.3	2.63 V	316	35.7	3.0
3	*5290.00	95.7 PK			2.63 V	316	92.4	3.3
4	*5290.00	82.7 AV			2.63 V	316	79.4	3.3
5	5350.00	49.7 PK	74.0	-24.3	2.63 V	316	46.2	3.5
6	5350.00	39.2 AV	54.0	-14.8	2.63 V	316	35.7	3.5
7	#10580.00	50.6 PK	74.0	-23.4	1.31 V	74	36.3	14.3
8	#10580.00	39.6 AV	54.0	-14.4	1.31 V	74	25.3	14.3
9	15870.00	50.6 PK	74.0	-23.4	2.98 V	157	35.6	15.0
10	15870.00	40.4 AV	54.0	-13.6	2.98 V	157	25.4	15.0

Remark:

1. Emission Level(dBuV/m) = Raw Value(dBuV) + Correction Factor(dB/m)
2. Correction Factor(dB/m) = Antenna Factor(dB/m) + Cable Factor(dB)
3. The other emission levels were very low against the limit.
4. Margin value = Emission Level – Limit value
5. " * ": Fundamental frequency.
6. " # ": The radiated frequency is out of the restricted band.

CHANNEL	TX Channel 106	DETECTOR FUNCTION	Peak (PK)
FREQUENCY RANGE	1GHz ~ 40GHz		Average (AV)

ANTENNA POLARITY & TEST DISTANCE: HORIZONTAL AT 3 M								
NO.	FREQ. (MHz)	EMISSION LEVEL (dBuV/m)	LIMIT (dBuV/m)	MARGIN (dB)	ANTENNA HEIGHT (m)	TABLE ANGLE (Degree)	RAW VALUE (dBuV)	CORRECTION FACTOR (dB/m)
1	#5466.00	73.2 PK	74.0	-0.8	2.74 H	186	69.5	3.7
2	#5466.00	53.1 AV	54.0	-0.9	2.74 H	186	49.4	3.7
3	*5530.00	107.1 PK			2.74 H	186	103.2	3.9
4	*5530.00	95.2 AV			2.74 H	186	91.3	3.9
5	11060.00	50.6 PK	74.0	-23.4	1.40 H	103	35.5	15.1
6	11060.00	39.6 AV	54.0	-14.4	1.40 H	103	24.5	15.1
7	#16590.00	51.4 PK	74.0	-22.6	2.13 H	294	33.7	17.7
8	#16590.00	41.1 AV	54.0	-12.9	2.13 H	294	23.4	17.7
ANTENNA POLARITY & TEST DISTANCE: VERTICAL AT 3 M								
NO.	FREQ. (MHz)	EMISSION LEVEL (dBuV/m)	LIMIT (dBuV/m)	MARGIN (dB)	ANTENNA HEIGHT (m)	TABLE ANGLE (Degree)	RAW VALUE (dBuV)	CORRECTION FACTOR (dB/m)
1	#5466.00	57.8 PK	74.0	-16.2	2.69 V	300	54.1	3.7
2	#5466.00	45.5 AV	54.0	-8.5	2.69 V	300	41.8	3.7
3	*5530.00	96.1 PK			2.69 V	300	92.2	3.9
4	*5530.00	85.1 AV			2.69 V	300	81.2	3.9
5	11060.00	50.3 PK	74.0	-23.7	1.19 V	91	35.2	15.1
6	11060.00	39.2 AV	54.0	-14.8	1.19 V	91	24.1	15.1
7	#16590.00	50.9 PK	74.0	-23.1	2.99 V	165	33.2	17.7
8	#16590.00	40.8 AV	54.0	-13.2	2.99 V	165	23.1	17.7

Remark:

1. Emission Level(dBuV/m) = Raw Value(dBuV) + Correction Factor(dB/m)
2. Correction Factor(dB/m) = Antenna Factor(dB/m) + Cable Factor(dB)
3. The other emission levels were very low against the limit.
4. Margin value = Emission Level – Limit value
5. " * ": Fundamental frequency.
6. " # ": The radiated frequency is out of the restricted band.

CHANNEL	TX Channel 122	DETECTOR FUNCTION	Peak (PK)
FREQUENCY RANGE	1GHz ~ 40GHz		Average (AV)

ANTENNA POLARITY & TEST DISTANCE: HORIZONTAL AT 3 M								
NO.	FREQ. (MHz)	EMISSION LEVEL (dBuV/m)	LIMIT (dBuV/m)	MARGIN (dB)	ANTENNA HEIGHT (m)	TABLE ANGLE (Degree)	RAW VALUE (dBuV)	CORRECTION FACTOR (dB/m)
1	*5610.00	112.0 PK			2.74 H	167	108.1	3.9
2	*5610.00	101.3 AV			2.74 H	167	97.4	3.9
3	#5730.00	68.2 PK	74.0	-5.8	2.74 H	167	64.0	4.2
4	#5730.00	52.1 AV	54.0	-1.9	2.74 H	167	47.9	4.2
5	11220.00	50.1 PK	74.0	-23.9	1.49 H	98	34.9	15.2
6	11220.00	39.1 AV	54.0	-14.9	1.49 H	98	23.9	15.2
7	#16830.00	51.6 PK	74.0	-22.4	2.06 H	300	33.1	18.5
8	#16830.00	41.2 AV	54.0	-12.8	2.06 H	300	22.7	18.5
ANTENNA POLARITY & TEST DISTANCE: VERTICAL AT 3 M								
NO.	FREQ. (MHz)	EMISSION LEVEL (dBuV/m)	LIMIT (dBuV/m)	MARGIN (dB)	ANTENNA HEIGHT (m)	TABLE ANGLE (Degree)	RAW VALUE (dBuV)	CORRECTION FACTOR (dB/m)
1	*5610.00	101.3 PK			2.59 V	299	97.4	3.9
2	*5610.00	90.2 AV			2.59 V	299	86.3	3.9
3	#5730.00	57.8 PK	74.0	-16.2	2.59 V	299	53.6	4.2
4	#5730.00	45.6 AV	54.0	-8.4	2.59 V	299	41.4	4.2
5	11220.00	50.3 PK	74.0	-23.7	1.28 V	81	35.1	15.2
6	11220.00	39.0 AV	54.0	-15.0	1.28 V	81	23.8	15.2
7	#16830.00	50.3 PK	74.0	-23.7	2.95 V	163	31.8	18.5
8	#16830.00	40.3 AV	54.0	-13.7	2.95 V	163	21.8	18.5

Remark:

1. Emission Level(dBuV/m) = Raw Value(dBuV) + Correction Factor(dB/m)
2. Correction Factor(dB/m) = Antenna Factor(dB/m) + Cable Factor(dB)
3. The other emission levels were very low against the limit.
4. Margin value = Emission Level – Limit value
5. " * ": Fundamental frequency.
6. " # ": The radiated frequency is out of the restricted band.

CHANNEL	TX Channel 138	DETECTOR FUNCTION	Peak (PK)
FREQUENCY RANGE	1GHz ~ 40GHz		Average (AV)

ANTENNA POLARITY & TEST DISTANCE: HORIZONTAL AT 3 M								
NO.	FREQ. (MHz)	EMISSION LEVEL (dBuV/m)	LIMIT (dBuV/m)	MARGIN (dB)	ANTENNA HEIGHT (m)	TABLE ANGLE (Degree)	RAW VALUE (dBuV)	CORRECTION FACTOR (dB/m)
1	#5470.00	57.3 PK	74.0	-16.7	2.77 H	153	53.6	3.7
2	#5470.00	45.3 AV	54.0	-8.7	2.77 H	153	41.6	3.7
3	*5690.00	113.2 PK			2.77 H	153	109.0	4.2
4	*5690.00	102.5 AV			2.77 H	153	98.3	4.2
5	#5850.00	57.4 PK	74.0	-16.6	2.77 H	153	53.2	4.2
6	#5850.00	45.3 AV	54.0	-8.7	2.77 H	153	41.1	4.2
7	11380.00	49.9 PK	74.0	-24.1	1.46 H	95	34.5	15.4
8	11380.00	38.9 AV	54.0	-15.1	1.46 H	95	23.5	15.4
9	#17070.00	51.6 PK	74.0	-22.4	2.03 H	301	31.6	20.0
10	#17070.00	41.4 AV	54.0	-12.6	2.03 H	301	21.4	20.0

ANTENNA POLARITY & TEST DISTANCE: VERTICAL AT 3 M								
NO.	FREQ. (MHz)	EMISSION LEVEL (dBuV/m)	LIMIT (dBuV/m)	MARGIN (dB)	ANTENNA HEIGHT (m)	TABLE ANGLE (Degree)	RAW VALUE (dBuV)	CORRECTION FACTOR (dB/m)
1	#5470.00	57.9 PK	74.0	-16.1	2.60 V	311	54.2	3.7
2	#5470.00	45.8 AV	54.0	-8.2	2.60 V	311	42.1	3.7
3	*5690.00	102.4 PK			2.60 V	311	98.2	4.2
4	*5690.00	91.3 AV			2.60 V	311	87.1	4.2
5	#5850.00	57.8 PK	74.0	-16.2	2.60 V	311	53.6	4.2
6	#5850.00	45.6 AV	54.0	-8.4	2.60 V	311	41.4	4.2
7	11380.00	50.2 PK	74.0	-23.8	1.26 V	86	34.8	15.4
8	11380.00	39.1 AV	54.0	-14.9	1.26 V	86	23.7	15.4
9	#17070.00	50.2 PK	74.0	-23.8	2.99 V	167	30.2	20.0
10	#17070.00	40.4 AV	54.0	-13.6	2.99 V	167	20.4	20.0

Remark:

1. Emission Level(dBuV/m) = Raw Value(dBuV) + Correction Factor(dB/m)
2. Correction Factor(dB/m) = Antenna Factor(dB/m) + Cable Factor(dB)
3. The other emission levels were very low against the limit.
4. Margin value = Emission Level – Limit value
5. " * ": Fundamental frequency.
6. " # ": The radiated frequency is out of the restricted band.

Radio 2 - 2TX with PIFA antenna CDD Mode

802.11a

CHANNEL	TX Channel 52	DETECTOR FUNCTION	Peak (PK)
FREQUENCY RANGE	1GHz ~ 40GHz		Average (AV)

ANTENNA POLARITY & TEST DISTANCE: HORIZONTAL AT 3 M

NO.	FREQ. (MHz)	EMISSION LEVEL (dBuV/m)	LIMIT (dBuV/m)	MARGIN (dB)	ANTENNA HEIGHT (m)	TABLE ANGLE (Degree)	RAW VALUE (dBuV)	CORRECTION FACTOR (dB/m)
1	5100.00	59.4 PK	74.0	-14.6	1.09 H	335	56.6	2.8
2	5100.00	40.0 AV	54.0	-14.0	1.09 H	335	37.2	2.8
3	*5260.00	106.2 PK			1.09 H	335	102.9	3.3
4	*5260.00	97.5 AV			1.09 H	335	94.2	3.3
5	5350.00	60.2 PK	74.0	-13.8	1.09 H	335	56.7	3.5
6	5350.00	40.5 AV	54.0	-13.5	1.09 H	335	37.0	3.5
7	#10520.00	50.8 PK	74.0	-23.2	1.46 H	322	36.7	14.1
8	#10520.00	39.4 AV	54.0	-14.6	1.46 H	322	25.3	14.1
9	15780.00	51.1 PK	74.0	-22.9	1.45 H	142	35.9	15.2
10	15780.00	41.1 AV	54.0	-12.9	1.45 H	142	25.9	15.2

ANTENNA POLARITY & TEST DISTANCE: VERTICAL AT 3 M

NO.	FREQ. (MHz)	EMISSION LEVEL (dBuV/m)	LIMIT (dBuV/m)	MARGIN (dB)	ANTENNA HEIGHT (m)	TABLE ANGLE (Degree)	RAW VALUE (dBuV)	CORRECTION FACTOR (dB/m)
1	5100.00	55.5 PK	74.0	-18.5	2.67 V	64	52.7	2.8
2	5100.00	44.8 AV	54.0	-9.2	2.67 V	64	42.0	2.8
3	*5260.00	118.2 PK			2.71 V	40	114.9	3.3
4	*5260.00	107.6 AV			2.71 V	40	104.3	3.3
5	5350.00	57.2 PK	74.0	-16.8	2.40 V	35	53.7	3.5
6	5350.00	46.1 AV	54.0	-7.9	2.40 V	35	42.6	3.5
7	#10520.00	50.3 PK	74.0	-23.7	1.06 V	360	36.2	14.1
8	#10520.00	39.1 AV	54.0	-14.9	1.06 V	360	25.0	14.1
9	15780.00	51.2 PK	74.0	-22.8	1.08 V	360	36.0	15.2
10	15780.00	41.0 AV	54.0	-13.0	1.08 V	360	25.8	15.2

Remark:

1. Emission Level(dBuV/m) = Raw Value(dBuV) + Correction Factor(dB/m)
2. Correction Factor(dB/m) = Antenna Factor(dB/m) + Cable Factor(dB)
3. The other emission levels were very low against the limit.
4. Margin value = Emission Level – Limit value
5. " * ": Fundamental frequency.
6. " # ": The radiated frequency is out of the restricted band.

CHANNEL	TX Channel 60	DETECTOR FUNCTION	Peak (PK)
FREQUENCY RANGE	1GHz ~ 40GHz		Average (AV)

ANTENNA POLARITY & TEST DISTANCE: HORIZONTAL AT 3 M								
NO.	FREQ. (MHz)	EMISSION LEVEL (dBuV/m)	LIMIT (dBuV/m)	MARGIN (dB)	ANTENNA HEIGHT (m)	TABLE ANGLE (Degree)	RAW VALUE (dBuV)	CORRECTION FACTOR (dB/m)
1	5140.00	59.1 PK	74.0	-14.9	1.07 H	1	56.1	3.0
2	5140.00	39.8 AV	54.0	-14.2	1.07 H	1	36.8	3.0
3	*5300.00	104.8 PK			1.07 H	1	101.5	3.3
4	*5300.00	95.9 AV			1.07 H	1	92.6	3.3
5	5361.00	59.2 PK	74.0	-14.8	1.07 H	1	55.7	3.5
6	5361.00	39.9 AV	54.0	-14.1	1.07 H	1	36.4	3.5
7	10600.00	50.4 PK	74.0	-23.6	1.45 H	324	36.1	14.3
8	10600.00	39.1 AV	54.0	-14.9	1.45 H	324	24.8	14.3
9	15900.00	50.9 PK	74.0	-23.1	1.42 H	128	35.8	15.1
10	15900.00	40.8 AV	54.0	-13.2	1.42 H	128	25.7	15.1

ANTENNA POLARITY & TEST DISTANCE: VERTICAL AT 3 M								
NO.	FREQ. (MHz)	EMISSION LEVEL (dBuV/m)	LIMIT (dBuV/m)	MARGIN (dB)	ANTENNA HEIGHT (m)	TABLE ANGLE (Degree)	RAW VALUE (dBuV)	CORRECTION FACTOR (dB/m)
1	5140.00	55.6 PK	74.0	-18.4	2.64 V	66	52.6	3.0
2	5140.00	44.6 AV	54.0	-9.4	2.64 V	66	41.6	3.0
3	*5300.00	117.6 PK			2.61 V	38	114.3	3.3
4	*5300.00	108.7 AV			2.61 V	38	105.4	3.3
5	5361.00	64.5 PK	74.0	-9.5	2.82 V	38	61.0	3.5
6	5361.00	49.7 AV	54.0	-4.3	2.82 V	38	46.2	3.5
7	10600.00	49.6 PK	74.0	-24.4	1.06 V	360	35.3	14.3
8	10600.00	38.7 AV	54.0	-15.3	1.06 V	360	24.4	14.3
9	15900.00	51.7 PK	74.0	-22.3	1.10 V	360	36.6	15.1
10	15900.00	41.5 AV	54.0	-12.5	1.10 V	360	26.4	15.1

Remark:

1. Emission Level(dBuV/m) = Raw Value(dBuV) + Correction Factor(dB/m)
2. Correction Factor(dB/m) = Antenna Factor(dB/m) + Cable Factor(dB)
3. The other emission levels were very low against the limit.
4. Margin value = Emission Level – Limit value
5. " * ": Fundamental frequency.
6. " # ": The radiated frequency is out of the restricted band.

CHANNEL	TX Channel 64	DETECTOR FUNCTION	Peak (PK)
FREQUENCY RANGE	1GHz ~ 40GHz		Average (AV)

ANTENNA POLARITY & TEST DISTANCE: HORIZONTAL AT 3 M								
NO.	FREQ. (MHz)	EMISSION LEVEL (dBuV/m)	LIMIT (dBuV/m)	MARGIN (dB)	ANTENNA HEIGHT (m)	TABLE ANGLE (Degree)	RAW VALUE (dBuV)	CORRECTION FACTOR (dB/m)
1	*5320.00	102.5 PK			1.13 H	19	99.0	3.5
2	*5320.00	93.4 AV			1.13 H	19	89.9	3.5
3	5350.00	57.9 PK	74.0	-16.1	1.13 H	19	54.4	3.5
4	5350.00	40.0 AV	54.0	-14.0	1.13 H	19	36.5	3.5
5	10640.00	51.5 PK	74.0	-22.5	1.52 H	330	37.2	14.3
6	10640.00	39.9 AV	54.0	-14.1	1.52 H	330	25.6	14.3
7	15960.00	51.2 PK	74.0	-22.8	1.45 H	144	36.1	15.1
8	15960.00	41.5 AV	54.0	-12.5	1.45 H	144	26.4	15.1
ANTENNA POLARITY & TEST DISTANCE: VERTICAL AT 3 M								
NO.	FREQ. (MHz)	EMISSION LEVEL (dBuV/m)	LIMIT (dBuV/m)	MARGIN (dB)	ANTENNA HEIGHT (m)	TABLE ANGLE (Degree)	RAW VALUE (dBuV)	CORRECTION FACTOR (dB/m)
1	*5320.00	115.9 PK			2.88 V	38	112.4	3.5
2	*5320.00	106.6 AV			2.88 V	38	103.1	3.5
3	5350.00	70.6 PK	74.0	-3.4	2.72 V	233	67.1	3.5
4	5350.00	53.0 AV	54.0	-1.0	2.72 V	233	49.5	3.5
5	10640.00	50.2 PK	74.0	-23.8	1.06 V	360	35.9	14.3
6	10640.00	39.1 AV	54.0	-14.9	1.06 V	360	24.8	14.3
7	15960.00	51.7 PK	74.0	-22.3	1.03 V	348	36.6	15.1
8	15960.00	41.3 AV	54.0	-12.7	1.03 V	348	26.2	15.1

Remark:

1. Emission Level(dBuV/m) = Raw Value(dBuV) + Correction Factor(dB/m)
2. Correction Factor(dB/m) = Antenna Factor(dB/m) + Cable Factor(dB)
3. The other emission levels were very low against the limit.
4. Margin value = Emission Level – Limit value
5. " * ": Fundamental frequency.
6. " # ": The radiated frequency is out of the restricted band.

CHANNEL	TX Channel 100	DETECTOR FUNCTION	Peak (PK)
FREQUENCY RANGE	1GHz ~ 40GHz		Average (AV)

ANTENNA POLARITY & TEST DISTANCE: HORIZONTAL AT 3 M

NO.	FREQ. (MHz)	EMISSION LEVEL (dBuV/m)	LIMIT (dBuV/m)	MARGIN (dB)	ANTENNA HEIGHT (m)	TABLE ANGLE (Degree)	RAW VALUE (dBuV)	CORRECTION FACTOR (dB/m)
1	#5470.00	59.6 PK	74.0	-14.4	1.07 H	13	55.9	3.7
2	#5470.00	40.1 AV	54.0	-13.9	1.07 H	13	36.4	3.7
3	*5500.00	101.9 PK			1.07 H	13	98.1	3.8
4	*5500.00	93.2 AV			1.07 H	13	89.4	3.8
5	#5735.00	59.7 PK	74.0	-14.3	1.07 H	13	55.5	4.2
6	#5735.00	40.4 AV	54.0	-13.6	1.07 H	13	36.2	4.2
7	11000.00	50.9 PK	74.0	-23.1	1.51 H	310	35.7	15.2
8	11000.00	39.3 AV	54.0	-14.7	1.51 H	310	24.1	15.2
9	#16500.00	50.7 PK	74.0	-23.3	1.41 H	137	33.3	17.4
10	#16500.00	40.7 AV	54.0	-13.3	1.41 H	137	23.3	17.4

ANTENNA POLARITY & TEST DISTANCE: VERTICAL AT 3 M

NO.	FREQ. (MHz)	EMISSION LEVEL (dBuV/m)	LIMIT (dBuV/m)	MARGIN (dB)	ANTENNA HEIGHT (m)	TABLE ANGLE (Degree)	RAW VALUE (dBuV)	CORRECTION FACTOR (dB/m)
1	#5470.00	72.8 PK	74.0	-1.2	2.71 V	37	69.1	3.7
2	#5470.00	53.1 AV	54.0	-0.9	2.71 V	37	49.4	3.7
3	*5500.00	114.9 PK			2.41 V	36	111.1	3.8
4	*5500.00	106.2 AV			2.41 V	36	102.4	3.8
5	#5735.00	59.8 PK	74.0	-14.2	2.41 V	36	55.6	4.2
6	#5735.00	49.9 AV	54.0	-4.1	2.41 V	36	45.7	4.2
7	11000.00	50.4 PK	74.0	-23.6	1.03 V	360	35.2	15.2
8	11000.00	39.5 AV	54.0	-14.5	1.03 V	360	24.3	15.2
9	#16500.00	51.7 PK	74.0	-22.3	1.10 V	348	34.3	17.4
10	#16500.00	41.2 AV	54.0	-12.8	1.10 V	348	23.8	17.4

Remark:

1. Emission Level(dBuV/m) = Raw Value(dBuV) + Correction Factor(dB/m)
2. Correction Factor(dB/m) = Antenna Factor(dB/m) + Cable Factor(dB)
3. The other emission levels were very low against the limit.
4. Margin value = Emission Level – Limit value
5. " * ": Fundamental frequency.
6. " # ": The radiated frequency is out of the restricted band.

CHANNEL	TX Channel 116	DETECTOR FUNCTION	Peak (PK)
FREQUENCY RANGE	1GHz ~ 40GHz		Average (AV)

ANTENNA POLARITY & TEST DISTANCE: HORIZONTAL AT 3 M

NO.	FREQ. (MHz)	EMISSION LEVEL (dBuV/m)	LIMIT (dBuV/m)	MARGIN (dB)	ANTENNA HEIGHT (m)	TABLE ANGLE (Degree)	RAW VALUE (dBuV)	CORRECTION FACTOR (dB/m)
1	5420.00	59.4 PK	74.0	-14.6	1.05 H	18	55.7	3.7
2	5420.00	40.2 AV	54.0	-13.8	1.05 H	18	36.5	3.7
3	*5580.00	104.1 PK			1.05 H	18	100.2	3.9
4	*5580.00	94.5 AV			1.05 H	18	90.6	3.9
5	#5740.00	59.5 PK	74.0	-14.5	1.05 H	18	55.3	4.2
6	#5740.00	40.2 AV	54.0	-13.8	1.05 H	18	36.0	4.2
7	11160.00	50.4 PK	74.0	-23.6	1.45 H	312	35.2	15.2
8	11160.00	38.9 AV	54.0	-15.1	1.45 H	312	23.7	15.2
9	#16740.00	50.6 PK	74.0	-23.4	1.48 H	129	32.3	18.3
10	#16740.00	40.9 AV	54.0	-13.1	1.48 H	129	22.6	18.3

ANTENNA POLARITY & TEST DISTANCE: VERTICAL AT 3 M

NO.	FREQ. (MHz)	EMISSION LEVEL (dBuV/m)	LIMIT (dBuV/m)	MARGIN (dB)	ANTENNA HEIGHT (m)	TABLE ANGLE (Degree)	RAW VALUE (dBuV)	CORRECTION FACTOR (dB/m)
1	5420.00	62.7 PK	74.0	-11.3	2.82 V	36	59.0	3.7
2	5420.00	53.1 AV	54.0	-0.9	2.82 V	36	49.4	3.7
3	*5580.00	117.3 PK			2.43 V	39	113.4	3.9
4	*5580.00	107.6 AV			2.43 V	39	103.7	3.9
5	#5740.00	62.2 PK	74.0	-11.8	2.76 V	38	58.0	4.2
6	#5740.00	53.3 AV	54.0	-0.7	2.76 V	38	49.1	4.2
7	11160.00	50.8 PK	74.0	-23.2	1.03 V	360	35.6	15.2
8	11160.00	39.4 AV	54.0	-14.6	1.03 V	360	24.2	15.2
9	#16740.00	50.9 PK	74.0	-23.1	1.04 V	347	32.6	18.3
10	#16740.00	40.6 AV	54.0	-13.4	1.04 V	347	22.3	18.3

Remark:

1. Emission Level(dBuV/m) = Raw Value(dBuV) + Correction Factor(dB/m)
2. Correction Factor(dB/m) = Antenna Factor(dB/m) + Cable Factor(dB)
3. The other emission levels were very low against the limit.
4. Margin value = Emission Level – Limit value
5. " * ": Fundamental frequency.
6. " # ": The radiated frequency is out of the restricted band.

CHANNEL	TX Channel 140	DETECTOR FUNCTION	Peak (PK)
FREQUENCY RANGE	1GHz ~ 40GHz		Average (AV)

ANTENNA POLARITY & TEST DISTANCE: HORIZONTAL AT 3 M

NO.	FREQ. (MHz)	EMISSION LEVEL (dBuV/m)	LIMIT (dBuV/m)	MARGIN (dB)	ANTENNA HEIGHT (m)	TABLE ANGLE (Degree)	RAW VALUE (dBuV)	CORRECTION FACTOR (dB/m)
1	#5463.00	55.4 PK	74.0	-18.6	1.03 H	16	51.7	3.7
2	#5463.00	40.9 AV	54.0	-13.1	1.03 H	16	37.2	3.7
3	*5700.00	102.3 PK			1.03 H	16	98.1	4.2
4	*5700.00	93.1 AV			1.03 H	16	88.9	4.2
5	#5727.00	55.5 PK	74.0	-18.5	1.03 H	16	51.3	4.2
6	#5727.00	40.9 AV	54.0	-13.1	1.03 H	16	36.7	4.2
7	11400.00	50.9 PK	74.0	-23.1	1.48 H	328	35.4	15.5
8	11400.00	39.6 AV	54.0	-14.4	1.48 H	328	24.1	15.5
9	#17100.00	51.1 PK	74.0	-22.9	1.48 H	130	31.0	20.1
10	#17100.00	41.2 AV	54.0	-12.8	1.48 H	130	21.1	20.1

ANTENNA POLARITY & TEST DISTANCE: VERTICAL AT 3 M

NO.	FREQ. (MHz)	EMISSION LEVEL (dBuV/m)	LIMIT (dBuV/m)	MARGIN (dB)	ANTENNA HEIGHT (m)	TABLE ANGLE (Degree)	RAW VALUE (dBuV)	CORRECTION FACTOR (dB/m)
1	#5463.00	59.9 PK	74.0	-14.1	2.35 V	38	56.2	3.7
2	#5463.00	50.4 AV	54.0	-3.6	2.35 V	38	46.7	3.7
3	*5700.00	115.3 PK			2.35 V	38	111.1	4.2
4	*5700.00	106.3 AV			2.35 V	38	102.1	4.2
5	#5727.00	73.5 PK	74.0	-0.5	2.43 V	35	69.3	4.2
6	#5727.00	53.1 AV	54.0	-0.9	2.43 V	35	48.9	4.2
7	11400.00	49.9 PK	74.0	-24.1	1.04 V	360	34.4	15.5
8	11400.00	38.6 AV	54.0	-15.4	1.04 V	360	23.1	15.5
9	#17100.00	51.1 PK	74.0	-22.9	1.08 V	360	31.0	20.1
10	#17100.00	40.9 AV	54.0	-13.1	1.08 V	360	20.8	20.1

Remark:

1. Emission Level(dBuV/m) = Raw Value(dBuV) + Correction Factor(dB/m)
2. Correction Factor(dB/m) = Antenna Factor(dB/m) + Cable Factor(dB)
3. The other emission levels were very low against the limit.
4. Margin value = Emission Level – Limit value
5. " * ": Fundamental frequency.
6. " # ": The radiated frequency is out of the restricted band.

CHANNEL	TX Channel 144	DETECTOR FUNCTION	Peak (PK)
FREQUENCY RANGE	1GHz ~ 40GHz		Average (AV)

ANTENNA POLARITY & TEST DISTANCE: HORIZONTAL AT 3 M

NO.	FREQ. (MHz)	EMISSION LEVEL (dBuV/m)	LIMIT (dBuV/m)	MARGIN (dB)	ANTENNA HEIGHT (m)	TABLE ANGLE (Degree)	RAW VALUE (dBuV)	CORRECTION FACTOR (dB/m)
1	5400.00	54.6 PK	74.0	-19.4	1.09 H	27	50.9	3.7
2	5400.00	40.4 AV	54.0	-13.6	1.09 H	27	36.7	3.7
3	*5720.00	106.0 PK			1.09 H	27	101.8	4.2
4	*5720.00	96.5 AV			1.09 H	27	92.3	4.2
5	#5880.00	59.8 PK	74.0	-14.2	1.09 H	27	55.6	4.2
6	#5880.00	50.0 AV	54.0	-4.0	1.09 H	27	45.8	4.2
7	11440.00	50.6 PK	74.0	-23.4	1.41 H	328	35.3	15.3
8	11440.00	39.1 AV	54.0	-14.9	1.41 H	328	23.8	15.3
9	#17160.00	51.0 PK	74.0	-23.0	1.39 H	140	31.2	19.8
10	#17160.00	40.8 AV	54.0	-13.2	1.39 H	140	21.0	19.8

ANTENNA POLARITY & TEST DISTANCE: VERTICAL AT 3 M

NO.	FREQ. (MHz)	EMISSION LEVEL (dBuV/m)	LIMIT (dBuV/m)	MARGIN (dB)	ANTENNA HEIGHT (m)	TABLE ANGLE (Degree)	RAW VALUE (dBuV)	CORRECTION FACTOR (dB/m)
1	5400.00	53.7 PK	74.0	-20.3	2.51 V	38	50.0	3.7
2	5400.00	43.1 AV	54.0	-10.9	2.51 V	38	39.4	3.7
3	*5720.00	118.9 PK			2.51 V	38	114.7	4.2
4	*5720.00	109.3 AV			2.51 V	38	105.1	4.2
5	#5880.00	52.1 PK	74.0	-21.9	2.51 V	38	47.9	4.2
6	#5880.00	40.6 AV	54.0	-13.4	2.51 V	38	36.4	4.2
7	11440.00	50.6 PK	74.0	-23.4	1.08 V	360	35.3	15.3
8	11440.00	39.6 AV	54.0	-14.4	1.08 V	360	24.3	15.3
9	#17160.00	51.6 PK	74.0	-22.4	1.04 V	356	31.8	19.8
10	#17160.00	41.2 AV	54.0	-12.8	1.04 V	356	21.4	19.8

Remark:

1. Emission Level(dBuV/m) = Raw Value(dBuV) + Correction Factor(dB/m)
2. Correction Factor(dB/m) = Antenna Factor(dB/m) + Cable Factor(dB)
3. The other emission levels were very low against the limit.
4. Margin value = Emission Level – Limit value
5. " * ": Fundamental frequency.
6. " # ": The radiated frequency is out of the restricted band.

802.11ac (VHT20)

CHANNEL	TX Channel 52	DETECTOR FUNCTION	Peak (PK)
FREQUENCY RANGE	1GHz ~ 40GHz		Average (AV)

ANTENNA POLARITY & TEST DISTANCE: HORIZONTAL AT 3 M

NO.	FREQ. (MHz)	EMISSION LEVEL (dBuV/m)	LIMIT (dBuV/m)	MARGIN (dB)	ANTENNA HEIGHT (m)	TABLE ANGLE (Degree)	RAW VALUE (dBuV)	CORRECTION FACTOR (dB/m)
1	5100.00	55.0 PK	74.0	-19.0	1.02 H	12	52.2	2.8
2	5100.00	40.7 AV	54.0	-13.3	1.02 H	12	37.9	2.8
3	*5260.00	105.4 PK			1.02 H	12	102.1	3.3
4	*5260.00	98.2 AV			1.02 H	12	94.9	3.3
5	5420.00	55.2 PK	74.0	-18.8	1.02 H	12	51.5	3.7
6	5420.00	41.0 AV	54.0	-13.0	1.02 H	12	37.3	3.7
7	#10520.00	51.1 PK	74.0	-22.9	1.48 H	316	37.0	14.1
8	#10520.00	39.5 AV	54.0	-14.5	1.48 H	316	25.4	14.1
9	15780.00	51.3 PK	74.0	-22.7	1.45 H	130	36.1	15.2
10	15780.00	41.1 AV	54.0	-12.9	1.45 H	130	25.9	15.2

ANTENNA POLARITY & TEST DISTANCE: VERTICAL AT 3 M

NO.	FREQ. (MHz)	EMISSION LEVEL (dBuV/m)	LIMIT (dBuV/m)	MARGIN (dB)	ANTENNA HEIGHT (m)	TABLE ANGLE (Degree)	RAW VALUE (dBuV)	CORRECTION FACTOR (dB/m)
1	5100.00	55.3 PK	74.0	-18.7	2.77 V	64	52.5	2.8
2	5100.00	44.5 AV	54.0	-9.5	2.77 V	64	41.7	2.8
3	*5260.00	118.5 PK			3.09 V	61	115.2	3.3
4	*5260.00	111.3 AV			3.09 V	61	108.0	3.3
5	5420.00	56.6 PK	74.0	-17.4	2.77 V	64	52.9	3.7
6	5420.00	46.9 AV	54.0	-7.1	2.77 V	64	43.2	3.7
7	#10520.00	50.3 PK	74.0	-23.7	1.01 V	360	36.2	14.1
8	#10520.00	39.2 AV	54.0	-14.8	1.01 V	360	25.1	14.1
9	15780.00	51.0 PK	74.0	-23.0	1.11 V	360	35.8	15.2
10	15780.00	40.9 AV	54.0	-13.1	1.11 V	360	25.7	15.2

Remark:

1. Emission Level(dBuV/m) = Raw Value(dBuV) + Correction Factor(dB/m)
2. Correction Factor(dB/m) = Antenna Factor(dB/m) + Cable Factor(dB)
3. The other emission levels were very low against the limit.
4. Margin value = Emission Level – Limit value
5. " * ": Fundamental frequency.
6. " # ": The radiated frequency is out of the restricted band.

CHANNEL	TX Channel 60	DETECTOR FUNCTION	Peak (PK)
FREQUENCY RANGE	1GHz ~ 40GHz		Average (AV)

ANTENNA POLARITY & TEST DISTANCE: HORIZONTAL AT 3 M

NO.	FREQ. (MHz)	EMISSION LEVEL (dBuV/m)	LIMIT (dBuV/m)	MARGIN (dB)	ANTENNA HEIGHT (m)	TABLE ANGLE (Degree)	RAW VALUE (dBuV)	CORRECTION FACTOR (dB/m)
1	5140.00	54.9 PK	74.0	-19.1	1.05 H	10	51.9	3.0
2	5140.00	40.6 AV	54.0	-13.4	1.05 H	10	37.6	3.0
3	*5300.00	107.5 PK			1.05 H	10	104.2	3.3
4	*5300.00	98.0 AV			1.05 H	10	94.7	3.3
5	5350.00	56.0 PK	74.0	-18.0	1.05 H	10	52.5	3.5
6	5350.00	41.4 AV	54.0	-12.6	1.05 H	10	37.9	3.5
7	10600.00	50.8 PK	74.0	-23.2	1.50 H	314	36.5	14.3
8	10600.00	39.2 AV	54.0	-14.8	1.50 H	314	24.9	14.3
9	15900.00	51.6 PK	74.0	-22.4	1.41 H	128	36.5	15.1
10	15900.00	41.5 AV	54.0	-12.5	1.41 H	128	26.4	15.1

ANTENNA POLARITY & TEST DISTANCE: VERTICAL AT 3 M

NO.	FREQ. (MHz)	EMISSION LEVEL (dBuV/m)	LIMIT (dBuV/m)	MARGIN (dB)	ANTENNA HEIGHT (m)	TABLE ANGLE (Degree)	RAW VALUE (dBuV)	CORRECTION FACTOR (dB/m)
1	5140.00	57.6 PK	74.0	-16.4	3.00 V	63	54.6	3.0
2	5140.00	44.9 AV	54.0	-9.1	3.00 V	63	41.9	3.0
3	*5300.00	120.7 PK			2.77 V	65	117.4	3.3
4	*5300.00	111.1 AV			2.77 V	65	107.8	3.3
5	5350.00	63.7 PK	74.0	-10.3	2.99 V	66	60.2	3.5
6	5350.00	50.2 AV	54.0	-3.8	2.99 V	66	46.7	3.5
7	10600.00	49.7 PK	74.0	-24.3	1.04 V	360	35.4	14.3
8	10600.00	38.7 AV	54.0	-15.3	1.04 V	360	24.4	14.3
9	15900.00	51.7 PK	74.0	-22.3	1.05 V	360	36.6	15.1
10	15900.00	41.3 AV	54.0	-12.7	1.05 V	360	26.2	15.1

Remark:

1. Emission Level(dBuV/m) = Raw Value(dBuV) + Correction Factor(dB/m)
2. Correction Factor(dB/m) = Antenna Factor(dB/m) + Cable Factor(dB)
3. The other emission levels were very low against the limit.
4. Margin value = Emission Level – Limit value
5. " * ": Fundamental frequency.
6. " # ": The radiated frequency is out of the restricted band.

CHANNEL	TX Channel 64	DETECTOR FUNCTION	Peak (PK)
FREQUENCY RANGE	1GHz ~ 40GHz		Average (AV)

ANTENNA POLARITY & TEST DISTANCE: HORIZONTAL AT 3 M								
NO.	FREQ. (MHz)	EMISSION LEVEL (dBuV/m)	LIMIT (dBuV/m)	MARGIN (dB)	ANTENNA HEIGHT (m)	TABLE ANGLE (Degree)	RAW VALUE (dBuV)	CORRECTION FACTOR (dB/m)
1	*5320.00	104.8 PK			1.08 H	26	101.3	3.5
2	*5320.00	94.3 AV			1.08 H	26	90.8	3.5
3	5350.00	55.1 PK	74.0	-18.9	1.08 H	26	51.6	3.5
4	5350.00	40.9 AV	54.0	-13.1	1.08 H	26	37.4	3.5
5	10640.00	50.9 PK	74.0	-23.1	1.46 H	332	36.6	14.3
6	10640.00	39.2 AV	54.0	-14.8	1.46 H	332	24.9	14.3
7	15960.00	50.9 PK	74.0	-23.1	1.50 H	147	35.8	15.1
8	15960.00	40.8 AV	54.0	-13.2	1.50 H	147	25.7	15.1
ANTENNA POLARITY & TEST DISTANCE: VERTICAL AT 3 M								
NO.	FREQ. (MHz)	EMISSION LEVEL (dBuV/m)	LIMIT (dBuV/m)	MARGIN (dB)	ANTENNA HEIGHT (m)	TABLE ANGLE (Degree)	RAW VALUE (dBuV)	CORRECTION FACTOR (dB/m)
1	*5320.00	117.3 PK			2.97 V	67	113.8	3.5
2	*5320.00	107.0 AV			2.97 V	67	103.5	3.5
3	5350.00	64.3 PK	74.0	-9.7	2.90 V	66	60.8	3.5
4	5350.00	53.2 AV	54.0	-0.8	2.90 V	66	49.7	3.5
5	10640.00	50.8 PK	74.0	-23.2	1.06 V	360	36.5	14.3
6	10640.00	39.3 AV	54.0	-14.7	1.06 V	360	25.0	14.3
7	15960.00	51.5 PK	74.0	-22.5	1.08 V	351	36.4	15.1
8	15960.00	41.3 AV	54.0	-12.7	1.08 V	351	26.2	15.1

Remark:

1. Emission Level(dBuV/m) = Raw Value(dBuV) + Correction Factor(dB/m)
2. Correction Factor(dB/m) = Antenna Factor(dB/m) + Cable Factor(dB)
3. The other emission levels were very low against the limit.
4. Margin value = Emission Level – Limit value
5. " * ": Fundamental frequency.
6. " # ": The radiated frequency is out of the restricted band.

CHANNEL	TX Channel 100	DETECTOR FUNCTION	Peak (PK)
FREQUENCY RANGE	1GHz ~ 40GHz		Average (AV)

ANTENNA POLARITY & TEST DISTANCE: HORIZONTAL AT 3 M

NO.	FREQ. (MHz)	EMISSION LEVEL (dBuV/m)	LIMIT (dBuV/m)	MARGIN (dB)	ANTENNA HEIGHT (m)	TABLE ANGLE (Degree)	RAW VALUE (dBuV)	CORRECTION FACTOR (dB/m)
1	#5470.00	55.3 PK	74.0	-18.7	1.01 H	13	51.6	3.7
2	#5470.00	40.7 AV	54.0	-13.3	1.01 H	13	37.0	3.7
3	*5500.00	102.7 PK			1.01 H	13	98.9	3.8
4	*5500.00	93.9 AV			1.01 H	13	90.1	3.8
5	11000.00	50.5 PK	74.0	-23.5	1.48 H	316	35.3	15.2
6	11000.00	39.1 AV	54.0	-14.9	1.48 H	316	23.9	15.2
7	#16500.00	50.7 PK	74.0	-23.3	1.48 H	132	33.3	17.4
8	#16500.00	40.9 AV	54.0	-13.1	1.48 H	132	23.5	17.4

ANTENNA POLARITY & TEST DISTANCE: VERTICAL AT 3 M

NO.	FREQ. (MHz)	EMISSION LEVEL (dBuV/m)	LIMIT (dBuV/m)	MARGIN (dB)	ANTENNA HEIGHT (m)	TABLE ANGLE (Degree)	RAW VALUE (dBuV)	CORRECTION FACTOR (dB/m)
1	#5470.00	68.5 PK	74.0	-5.5	2.96 V	33	64.8	3.7
2	#5470.00	53.2 AV	54.0	-0.8	2.96 V	33	49.5	3.7
3	*5500.00	115.9 PK			2.84 V	34	112.1	3.8
4	*5500.00	107.1 AV			2.84 V	34	103.3	3.8
5	11000.00	49.9 PK	74.0	-24.1	1.11 V	360	34.7	15.2
6	11000.00	38.9 AV	54.0	-15.1	1.11 V	360	23.7	15.2
7	#16500.00	51.0 PK	74.0	-23.0	1.04 V	360	33.6	17.4
8	#16500.00	40.7 AV	54.0	-13.3	1.04 V	360	23.3	17.4

Remark:

1. Emission Level(dBuV/m) = Raw Value(dBuV) + Correction Factor(dB/m)
2. Correction Factor(dB/m) = Antenna Factor(dB/m) + Cable Factor(dB)
3. The other emission levels were very low against the limit.
4. Margin value = Emission Level – Limit value
5. " * ": Fundamental frequency.
6. " # ": The radiated frequency is out of the restricted band.

CHANNEL	TX Channel 116	DETECTOR FUNCTION	Peak (PK)
FREQUENCY RANGE	1GHz ~ 40GHz		Average (AV)

ANTENNA POLARITY & TEST DISTANCE: HORIZONTAL AT 3 M								
NO.	FREQ. (MHz)	EMISSION LEVEL (dBuV/m)	LIMIT (dBuV/m)	MARGIN (dB)	ANTENNA HEIGHT (m)	TABLE ANGLE (Degree)	RAW VALUE (dBuV)	CORRECTION FACTOR (dB/m)
1	5420.00	54.7 PK	74.0	-19.3	1.06 H	17	51.0	3.7
2	5420.00	40.7 AV	54.0	-13.3	1.06 H	17	37.0	3.7
3	*5580.00	102.9 PK			1.06 H	17	99.0	3.9
4	*5580.00	93.4 AV			1.06 H	17	89.5	3.9
5	11160.00	51.0 PK	74.0	-23.0	1.45 H	337	35.8	15.2
6	11160.00	39.5 AV	54.0	-14.5	1.45 H	337	24.3	15.2
7	#16740.00	50.6 PK	74.0	-23.4	1.42 H	152	32.3	18.3
8	#16740.00	40.6 AV	54.0	-13.4	1.42 H	152	22.3	18.3
ANTENNA POLARITY & TEST DISTANCE: VERTICAL AT 3 M								
NO.	FREQ. (MHz)	EMISSION LEVEL (dBuV/m)	LIMIT (dBuV/m)	MARGIN (dB)	ANTENNA HEIGHT (m)	TABLE ANGLE (Degree)	RAW VALUE (dBuV)	CORRECTION FACTOR (dB/m)
1	5420.00	62.1 PK	74.0	-11.9	2.97 V	65	58.4	3.7
2	5420.00	53.1 AV	54.0	-0.9	2.97 V	65	49.4	3.7
3	*5580.00	116.1 PK			3.00 V	38	112.2	3.9
4	*5580.00	106.9 AV			3.00 V	38	103.0	3.9
5	11160.00	49.7 PK	74.0	-24.3	1.02 V	360	34.5	15.2
6	11160.00	38.6 AV	54.0	-15.4	1.02 V	360	23.4	15.2
7	#16740.00	51.8 PK	74.0	-22.2	1.14 V	355	33.5	18.3
8	#16740.00	41.4 AV	54.0	-12.6	1.14 V	355	23.1	18.3

Remark:

1. Emission Level(dBuV/m) = Raw Value(dBuV) + Correction Factor(dB/m)
2. Correction Factor(dB/m) = Antenna Factor(dB/m) + Cable Factor(dB)
3. The other emission levels were very low against the limit.
4. Margin value = Emission Level – Limit value
5. " * ": Fundamental frequency.
6. " # ": The radiated frequency is out of the restricted band.

CHANNEL	TX Channel 140	DETECTOR FUNCTION	Peak (PK)
FREQUENCY RANGE	1GHz ~ 40GHz		Average (AV)

ANTENNA POLARITY & TEST DISTANCE: HORIZONTAL AT 3 M

NO.	FREQ. (MHz)	EMISSION LEVEL (dBuV/m)	LIMIT (dBuV/m)	MARGIN (dB)	ANTENNA HEIGHT (m)	TABLE ANGLE (Degree)	RAW VALUE (dBuV)	CORRECTION FACTOR (dB/m)
1	5460.00	54.8 PK	74.0	-19.2	1.05 H	33	51.1	3.7
2	5460.00	40.5 AV	54.0	-13.5	1.05 H	33	36.8	3.7
3	*5700.00	101.7 PK			1.05 H	33	97.5	4.2
4	*5700.00	92.4 AV			1.05 H	33	88.2	4.2
5	#5725.00	54.9 PK	74.0	-19.1	1.05 H	33	50.7	4.2
6	#5725.00	40.7 AV	54.0	-13.3	1.05 H	33	36.5	4.2
7	#5860.00	55.2 PK	74.0	-18.8	1.05 H	33	51.0	4.2
8	#5860.00	40.8 AV	54.0	-13.2	1.05 H	33	36.6	4.2
9	#5940.00	55.1 PK	74.0	-18.9	1.05 H	33	50.7	4.4
10	#5940.00	40.8 AV	54.0	-13.2	1.05 H	33	36.4	4.4
11	11400.00	50.2 PK	74.0	-23.8	1.50 H	320	34.7	15.5
12	11400.00	39.0 AV	54.0	-15.0	1.50 H	320	23.5	15.5
13	#17100.00	50.8 PK	74.0	-23.2	1.49 H	156	30.7	20.1
14	#17100.00	40.9 AV	54.0	-13.1	1.49 H	156	20.8	20.1

ANTENNA POLARITY & TEST DISTANCE: VERTICAL AT 3 M

NO.	FREQ. (MHz)	EMISSION LEVEL (dBuV/m)	LIMIT (dBuV/m)	MARGIN (dB)	ANTENNA HEIGHT (m)	TABLE ANGLE (Degree)	RAW VALUE (dBuV)	CORRECTION FACTOR (dB/m)
1	5460.00	59.3 PK	74.0	-14.7	2.66 V	136	55.6	3.7
2	5460.00	49.2 AV	54.0	-4.8	2.66 V	136	45.5	3.7
3	*5700.00	113.9 PK			2.65 V	136	109.7	4.2
4	*5700.00	104.9 AV			2.65 V	136	100.7	4.2
5	#5725.00	69.5 PK	74.0	-4.5	2.91 V	41	65.3	4.2
6	#5725.00	53.8 AV	54.0	-0.2	2.91 V	41	49.6	4.2
7	#5860.00	59.0 PK	74.0	-15.0	2.71 V	44	54.8	4.2
8	#5860.00	49.4 AV	54.0	-4.6	2.71 V	44	45.2	4.2
9	#5940.00	58.3 PK	74.0	-15.7	2.62 V	134	53.9	4.4
10	#5940.00	47.3 AV	54.0	-6.7	2.62 V	134	42.9	4.4
11	11400.00	50.8 PK	74.0	-23.2	1.04 V	359	35.3	15.5
12	11400.00	39.3 AV	54.0	-14.7	1.04 V	359	23.8	15.5
13	#17100.00	51.5 PK	74.0	-22.5	1.08 V	348	31.4	20.1
14	#17100.00	41.5 AV	54.0	-12.5	1.08 V	348	21.4	20.1

Remark:

1. Emission Level(dBuV/m) = Raw Value(dBuV) + Correction Factor(dB/m)
2. Correction Factor(dB/m) = Antenna Factor(dB/m) + Cable Factor(dB)
3. The other emission levels were very low against the limit.
4. Margin value = Emission Level – Limit value
5. " * ": Fundamental frequency.
6. " # ": The radiated frequency is out of the restricted band.

CHANNEL	TX Channel 144	DETECTOR FUNCTION	Peak (PK)
FREQUENCY RANGE	1GHz ~ 40GHz		Average (AV)

ANTENNA POLARITY & TEST DISTANCE: HORIZONTAL AT 3 M								
NO.	FREQ. (MHz)	EMISSION LEVEL (dBuV/m)	LIMIT (dBuV/m)	MARGIN (dB)	ANTENNA HEIGHT (m)	TABLE ANGLE (Degree)	RAW VALUE (dBuV)	CORRECTION FACTOR (dB/m)
1	5400.00	55.0 PK	74.0	-19.0	1.04 H	9	51.3	3.7
2	5400.00	40.8 AV	54.0	-13.2	1.04 H	9	37.1	3.7
3	*5720.00	105.3 PK			1.04 H	9	101.1	4.2
4	*5720.00	94.9 AV			1.04 H	9	90.7	4.2
5	#5880.00	55.0 PK	74.0	-19.0	1.04 H	9	50.8	4.2
6	#5880.00	40.7 AV	54.0	-13.3	1.04 H	9	36.5	4.2
7	11440.00	50.8 PK	74.0	-23.2	1.50 H	312	35.5	15.3
8	11440.00	39.5 AV	54.0	-14.5	1.50 H	312	24.2	15.3
9	#17160.00	51.1 PK	74.0	-22.9	1.44 H	145	31.3	19.8
10	#17160.00	41.4 AV	54.0	-12.6	1.44 H	145	21.6	19.8

ANTENNA POLARITY & TEST DISTANCE: VERTICAL AT 3 M								
NO.	FREQ. (MHz)	EMISSION LEVEL (dBuV/m)	LIMIT (dBuV/m)	MARGIN (dB)	ANTENNA HEIGHT (m)	TABLE ANGLE (Degree)	RAW VALUE (dBuV)	CORRECTION FACTOR (dB/m)
1	5400.00	52.9 PK	74.0	-21.1	2.44 V	132	49.2	3.7
2	5400.00	41.3 AV	54.0	-12.7	2.44 V	132	37.6	3.7
3	*5720.00	117.9 PK			2.80 V	135	113.7	4.2
4	*5720.00	107.7 AV			2.80 V	135	103.5	4.2
5	#5880.00	62.7 PK	74.0	-11.3	2.80 V	132	58.5	4.2
6	#5880.00	53.7 AV	54.0	-0.3	2.80 V	132	49.5	4.2
7	11440.00	50.4 PK	74.0	-23.6	1.04 V	360	35.1	15.3
8	11440.00	39.0 AV	54.0	-15.0	1.04 V	360	23.7	15.3
9	#17160.00	51.6 PK	74.0	-22.4	1.13 V	359	31.8	19.8
10	#17160.00	41.1 AV	54.0	-12.9	1.13 V	359	21.3	19.8

Remark:

1. Emission Level(dBuV/m) = Raw Value(dBuV) + Correction Factor(dB/m)
2. Correction Factor(dB/m) = Antenna Factor(dB/m) + Cable Factor(dB)
3. The other emission levels were very low against the limit.
4. Margin value = Emission Level – Limit value
5. " * " : Fundamental frequency.
6. " # " : The radiated frequency is out of the restricted band.

802.11ac (VHT40)

CHANNEL	TX Channel 54	DETECTOR FUNCTION	Peak (PK)
FREQUENCY RANGE	1GHz ~ 40GHz		Average (AV)

ANTENNA POLARITY & TEST DISTANCE: HORIZONTAL AT 3 M

NO.	FREQ. (MHz)	EMISSION LEVEL (dBuV/m)	LIMIT (dBuV/m)	MARGIN (dB)	ANTENNA HEIGHT (m)	TABLE ANGLE (Degree)	RAW VALUE (dBuV)	CORRECTION FACTOR (dB/m)
1	*5270.00	103.5 PK			1.11 H	24	100.2	3.3
2	*5270.00	93.6 AV			1.11 H	24	90.3	3.3
3	5350.00	55.4 PK	74.0	-18.6	1.11 H	24	51.9	3.5
4	5350.00	41.2 AV	54.0	-12.8	1.11 H	24	37.7	3.5
5	5430.00	55.0 PK	74.0	-19.0	1.11 H	24	51.3	3.7
6	5430.00	40.9 AV	54.0	-13.1	1.11 H	24	37.2	3.7
7	#10540.00	50.5 PK	74.0	-23.5	1.44 H	336	36.3	14.2
8	#10540.00	39.0 AV	54.0	-15.0	1.44 H	336	24.8	14.2
9	15810.00	51.6 PK	74.0	-22.4	1.39 H	152	36.6	15.0
10	15810.00	41.5 AV	54.0	-12.5	1.39 H	152	26.5	15.0

ANTENNA POLARITY & TEST DISTANCE: VERTICAL AT 3 M

NO.	FREQ. (MHz)	EMISSION LEVEL (dBuV/m)	LIMIT (dBuV/m)	MARGIN (dB)	ANTENNA HEIGHT (m)	TABLE ANGLE (Degree)	RAW VALUE (dBuV)	CORRECTION FACTOR (dB/m)
1	*5270.00	117.0 PK			3.06 V	63	113.7	3.3
2	*5270.00	107.1 AV			3.06 V	63	103.8	3.3
3	5350.00	68.9 PK	74.0	-5.1	2.79 V	64	65.4	3.5
4	5350.00	53.4 AV	54.0	-0.6	2.79 V	64	49.9	3.5
5	5430.00	60.6 PK	74.0	-13.4	2.79 V	138	56.9	3.7
6	5430.00	51.2 AV	54.0	-2.8	2.79 V	138	47.5	3.7
7	#10540.00	50.0 PK	74.0	-24.0	1.09 V	360	35.8	14.2
8	#10540.00	39.0 AV	54.0	-15.0	1.09 V	360	24.8	14.2
9	15810.00	50.6 PK	74.0	-23.4	1.13 V	360	35.6	15.0
10	15810.00	40.7 AV	54.0	-13.3	1.13 V	360	25.7	15.0

Remark:

1. Emission Level(dBuV/m) = Raw Value(dBuV) + Correction Factor(dB/m)
2. Correction Factor(dB/m) = Antenna Factor(dB/m) + Cable Factor(dB)
3. The other emission levels were very low against the limit.
4. Margin value = Emission Level – Limit value
5. " * ": Fundamental frequency.
6. " # ": The radiated frequency is out of the restricted band.

CHANNEL	TX Channel 62	DETECTOR FUNCTION	Peak (PK)
FREQUENCY RANGE	1GHz ~ 40GHz		Average (AV)

ANTENNA POLARITY & TEST DISTANCE: HORIZONTAL AT 3 M								
NO.	FREQ. (MHz)	EMISSION LEVEL (dBuV/m)	LIMIT (dBuV/m)	MARGIN (dB)	ANTENNA HEIGHT (m)	TABLE ANGLE (Degree)	RAW VALUE (dBuV)	CORRECTION FACTOR (dB/m)
1	*5310.00	98.0 PK			1.02 H	29	94.6	3.4
2	*5310.00	87.6 AV			1.02 H	29	84.2	3.4
3	5350.00	55.9 PK	74.0	-18.1	1.02 H	29	52.4	3.5
4	5350.00	41.3 AV	54.0	-12.7	1.02 H	29	37.8	3.5
5	10620.00	50.6 PK	74.0	-23.4	1.50 H	318	36.3	14.3
6	10620.00	39.0 AV	54.0	-15.0	1.50 H	318	24.7	14.3
7	15930.00	51.4 PK	74.0	-22.6	1.39 H	151	36.3	15.1
8	15930.00	41.2 AV	54.0	-12.8	1.39 H	151	26.1	15.1
ANTENNA POLARITY & TEST DISTANCE: VERTICAL AT 3 M								
NO.	FREQ. (MHz)	EMISSION LEVEL (dBuV/m)	LIMIT (dBuV/m)	MARGIN (dB)	ANTENNA HEIGHT (m)	TABLE ANGLE (Degree)	RAW VALUE (dBuV)	CORRECTION FACTOR (dB/m)
1	*5310.00	111.2 PK			3.05 V	66	107.8	3.4
2	*5310.00	100.9 AV			3.05 V	66	97.5	3.4
3	5350.00	73.8 PK	74.0	-0.2	3.05 V	63	70.3	3.5
4	5350.00	53.3 AV	54.0	-0.7	3.05 V	63	49.8	3.5
5	10620.00	50.2 PK	74.0	-23.8	1.00 V	360	35.9	14.3
6	10620.00	38.9 AV	54.0	-15.1	1.00 V	360	24.6	14.3
7	15930.00	51.8 PK	74.0	-22.2	1.06 V	360	36.7	15.1
8	15930.00	41.4 AV	54.0	-12.6	1.06 V	360	26.3	15.1

Remark:

1. Emission Level(dBuV/m) = Raw Value(dBuV) + Correction Factor(dB/m)
2. Correction Factor(dB/m) = Antenna Factor(dB/m) + Cable Factor(dB)
3. The other emission levels were very low against the limit.
4. Margin value = Emission Level – Limit value
5. " * ": Fundamental frequency.
6. " # ": The radiated frequency is out of the restricted band.

CHANNEL	TX Channel 102	DETECTOR FUNCTION	Peak (PK)
FREQUENCY RANGE	1GHz ~ 40GHz		Average (AV)

ANTENNA POLARITY & TEST DISTANCE: HORIZONTAL AT 3 M								
NO.	FREQ. (MHz)	EMISSION LEVEL (dBuV/m)	LIMIT (dBuV/m)	MARGIN (dB)	ANTENNA HEIGHT (m)	TABLE ANGLE (Degree)	RAW VALUE (dBuV)	CORRECTION FACTOR (dB/m)
1	#5470.00	55.5 PK	74.0	-18.5	1.09 H	29	51.8	3.7
2	#5470.00	41.3 AV	54.0	-12.7	1.09 H	29	37.6	3.7
3	*5510.00	97.3 PK			1.09 H	29	93.5	3.8
4	*5510.00	87.9 AV			1.09 H	29	84.1	3.8
5	11020.00	50.7 PK	74.0	-23.3	1.44 H	329	35.6	15.1
6	11020.00	39.3 AV	54.0	-14.7	1.44 H	329	24.2	15.1
7	#16530.00	51.9 PK	74.0	-22.1	1.45 H	152	34.4	17.5
8	#16530.00	41.6 AV	54.0	-12.4	1.45 H	152	24.1	17.5

ANTENNA POLARITY & TEST DISTANCE: VERTICAL AT 3 M								
NO.	FREQ. (MHz)	EMISSION LEVEL (dBuV/m)	LIMIT (dBuV/m)	MARGIN (dB)	ANTENNA HEIGHT (m)	TABLE ANGLE (Degree)	RAW VALUE (dBuV)	CORRECTION FACTOR (dB/m)
1	#5470.00	67.0 PK	74.0	-7.0	3.16 V	33	63.3	3.7
2	#5470.00	53.4 AV	54.0	-0.6	3.16 V	33	49.7	3.7
3	*5510.00	110.0 PK			3.12 V	36	106.2	3.8
4	*5510.00	100.6 AV			3.12 V	36	96.8	3.8
5	11020.00	50.4 PK	74.0	-23.6	1.06 V	357	35.3	15.1
6	11020.00	39.1 AV	54.0	-14.9	1.06 V	357	24.0	15.1
7	#16530.00	51.3 PK	74.0	-22.7	1.13 V	360	33.8	17.5
8	#16530.00	41.3 AV	54.0	-12.7	1.13 V	360	23.8	17.5

Remark:

1. Emission Level(dBuV/m) = Raw Value(dBuV) + Correction Factor(dB/m)
2. Correction Factor(dB/m) = Antenna Factor(dB/m) + Cable Factor(dB)
3. The other emission levels were very low against the limit.
4. Margin value = Emission Level – Limit value
5. " * ": Fundamental frequency.
6. " # ": The radiated frequency is out of the restricted band.

CHANNEL	TX Channel 110	DETECTOR FUNCTION	Peak (PK)
FREQUENCY RANGE	1GHz ~ 40GHz		Average (AV)

ANTENNA POLARITY & TEST DISTANCE: HORIZONTAL AT 3 M

NO.	FREQ. (MHz)	EMISSION LEVEL (dBuV/m)	LIMIT (dBuV/m)	MARGIN (dB)	ANTENNA HEIGHT (m)	TABLE ANGLE (Degree)	RAW VALUE (dBuV)	CORRECTION FACTOR (dB/m)
1	5390.00	50.7 PK	74.0	-23.3	1.09 H	12	47.0	3.7
2	5390.00	40.2 AV	54.0	-13.8	1.09 H	12	36.5	3.7
3	*5550.00	101.0 PK			1.09 H	12	97.1	3.9
4	*5550.00	91.8 AV			1.09 H	12	87.9	3.9
5	#5725.00	49.0 PK	74.0	-25.0	1.09 H	12	44.8	4.2
6	#5725.00	39.8 AV	54.0	-14.2	1.09 H	12	35.6	4.2
7	11100.00	51.0 PK	74.0	-23.0	1.44 H	338	35.9	15.1
8	11100.00	39.8 AV	54.0	-14.2	1.44 H	338	24.7	15.1
9	#16650.00	50.6 PK	74.0	-23.4	1.43 H	142	32.6	18.0
10	#16650.00	40.7 AV	54.0	-13.3	1.43 H	142	22.7	18.0

ANTENNA POLARITY & TEST DISTANCE: VERTICAL AT 3 M

NO.	FREQ. (MHz)	EMISSION LEVEL (dBuV/m)	LIMIT (dBuV/m)	MARGIN (dB)	ANTENNA HEIGHT (m)	TABLE ANGLE (Degree)	RAW VALUE (dBuV)	CORRECTION FACTOR (dB/m)
1	5390.00	63.6 PK	74.0	-10.4	3.09 V	67	59.9	3.7
2	5390.00	53.3 AV	54.0	-0.7	3.09 V	67	49.6	3.7
3	*5550.00	113.9 PK			3.12 V	69	110.0	3.9
4	*5550.00	104.6 AV			3.12 V	69	100.7	3.9
5	#5725.00	62.4 PK	74.0	-11.6	3.15 V	132	58.2	4.2
6	#5725.00	52.9 AV	54.0	-1.1	3.15 V	132	48.7	4.2
7	11100.00	50.0 PK	74.0	-24.0	1.05 V	360	34.9	15.1
8	11100.00	39.1 AV	54.0	-14.9	1.05 V	360	24.0	15.1
9	#16650.00	51.1 PK	74.0	-22.9	1.14 V	348	33.1	18.0
10	#16650.00	40.6 AV	54.0	-13.4	1.14 V	348	22.6	18.0

Remark:

1. Emission Level(dBuV/m) = Raw Value(dBuV) + Correction Factor(dB/m)
2. Correction Factor(dB/m) = Antenna Factor(dB/m) + Cable Factor(dB)
3. The other emission levels were very low against the limit.
4. Margin value = Emission Level – Limit value
5. " * ": Fundamental frequency.
6. " # ": The radiated frequency is out of the restricted band.

CHANNEL	TX Channel 134	DETECTOR FUNCTION	Peak (PK)
FREQUENCY RANGE	1GHz ~ 40GHz		Average (AV)

ANTENNA POLARITY & TEST DISTANCE: HORIZONTAL AT 3 M								
NO.	FREQ. (MHz)	EMISSION LEVEL (dBuV/m)	LIMIT (dBuV/m)	MARGIN (dB)	ANTENNA HEIGHT (m)	TABLE ANGLE (Degree)	RAW VALUE (dBuV)	CORRECTION FACTOR (dB/m)
1	5430.00	55.7 PK	74.0	-18.3	1.05 H	20	52.0	3.7
2	5430.00	40.4 AV	54.0	-13.6	1.05 H	20	36.7	3.7
3	*5670.00	99.3 PK			1.05 H	20	95.3	4.0
4	*5670.00	88.9 AV			1.05 H	20	84.9	4.0
5	#5725.00	55.9 PK	74.0	-18.1	1.05 H	20	51.7	4.2
6	#5725.00	40.4 AV	54.0	-13.6	1.05 H	20	36.2	4.2
7	11340.00	50.7 PK	74.0	-23.3	1.46 H	333	35.4	15.3
8	11340.00	39.6 AV	54.0	-14.4	1.46 H	333	24.3	15.3
9	#17010.00	51.2 PK	74.0	-22.8	1.49 H	143	31.3	19.9
10	#17010.00	41.5 AV	54.0	-12.5	1.49 H	143	21.6	19.9

ANTENNA POLARITY & TEST DISTANCE: VERTICAL AT 3 M								
NO.	FREQ. (MHz)	EMISSION LEVEL (dBuV/m)	LIMIT (dBuV/m)	MARGIN (dB)	ANTENNA HEIGHT (m)	TABLE ANGLE (Degree)	RAW VALUE (dBuV)	CORRECTION FACTOR (dB/m)
1	5430.00	56.0 PK	74.0	-18.0	2.94 V	34	52.3	3.7
2	5430.00	46.2 AV	54.0	-7.8	2.94 V	34	42.5	3.7
3	*5670.00	111.8 PK			2.94 V	46	107.8	4.0
4	*5670.00	101.5 AV			2.94 V	46	97.5	4.0
5	#5725.00	68.9 PK	74.0	-5.1	3.24 V	133	64.7	4.2
6	#5725.00	53.2 AV	54.0	-0.8	3.24 V	133	49.0	4.2
7	11340.00	50.0 PK	74.0	-24.0	1.10 V	360	34.7	15.3
8	11340.00	38.9 AV	54.0	-15.1	1.10 V	360	23.6	15.3
9	#17010.00	51.3 PK	74.0	-22.7	1.07 V	360	31.4	19.9
10	#17010.00	41.3 AV	54.0	-12.7	1.07 V	360	21.4	19.9

Remark:

1. Emission Level(dBuV/m) = Raw Value(dBuV) + Correction Factor(dB/m)
2. Correction Factor(dB/m) = Antenna Factor(dB/m) + Cable Factor(dB)
3. The other emission levels were very low against the limit.
4. Margin value = Emission Level – Limit value
5. " * ": Fundamental frequency.
6. " # ": The radiated frequency is out of the restricted band.

CHANNEL	TX Channel 142	DETECTOR FUNCTION	Peak (PK)
FREQUENCY RANGE	1GHz ~ 40GHz		Average (AV)

ANTENNA POLARITY & TEST DISTANCE: HORIZONTAL AT 3 M								
NO.	FREQ. (MHz)	EMISSION LEVEL (dBuV/m)	LIMIT (dBuV/m)	MARGIN (dB)	ANTENNA HEIGHT (m)	TABLE ANGLE (Degree)	RAW VALUE (dBuV)	CORRECTION FACTOR (dB/m)
1	#5470.00	55.7 PK	74.0	-18.3	1.09 H	3	52.0	3.7
2	#5470.00	41.3 AV	54.0	-12.7	1.09 H	3	37.6	3.7
3	*5710.00	101.8 PK			1.09 H	3	97.6	4.2
4	*5710.00	91.9 AV			1.09 H	3	87.7	4.2
5	#5850.00	54.6 PK	74.0	-19.4	1.09 H	3	50.4	4.2
6	#5850.00	40.4 AV	54.0	-13.6	1.09 H	3	36.2	4.2
7	11420.00	50.9 PK	74.0	-23.1	1.52 H	308	35.5	15.4
8	11420.00	39.5 AV	54.0	-14.5	1.52 H	308	24.1	15.4
9	#17130.00	50.8 PK	74.0	-23.2	1.40 H	128	30.8	20.0
10	#17130.00	40.6 AV	54.0	-13.4	1.40 H	128	20.6	20.0

ANTENNA POLARITY & TEST DISTANCE: VERTICAL AT 3 M								
NO.	FREQ. (MHz)	EMISSION LEVEL (dBuV/m)	LIMIT (dBuV/m)	MARGIN (dB)	ANTENNA HEIGHT (m)	TABLE ANGLE (Degree)	RAW VALUE (dBuV)	CORRECTION FACTOR (dB/m)
1	#5470.00	58.9 PK	74.0	-15.1	2.95 V	135	55.2	3.7
2	#5470.00	49.1 AV	54.0	-4.9	2.95 V	135	45.4	3.7
3	*5710.00	115.1 PK			2.96 V	135	110.9	4.2
4	*5710.00	105.4 AV			2.96 V	135	101.2	4.2
5	#5850.00	61.7 PK	74.0	-12.3	2.95 V	134	57.5	4.2
6	#5850.00	51.6 AV	54.0	-2.4	2.95 V	134	47.4	4.2
7	11420.00	50.4 PK	74.0	-23.6	1.04 V	360	35.0	15.4
8	11420.00	39.2 AV	54.0	-14.8	1.04 V	360	23.8	15.4
9	#17130.00	51.7 PK	74.0	-22.3	1.06 V	360	31.7	20.0
10	#17130.00	41.4 AV	54.0	-12.6	1.06 V	360	21.4	20.0

Remark:

1. Emission Level(dBuV/m) = Raw Value(dBuV) + Correction Factor(dB/m)
2. Correction Factor(dB/m) = Antenna Factor(dB/m) + Cable Factor(dB)
3. The other emission levels were very low against the limit.
4. Margin value = Emission Level – Limit value
5. " * ": Fundamental frequency.
6. " # ": The radiated frequency is out of the restricted band.

802.11ac (VHT80)

CHANNEL	TX Channel 58	DETECTOR FUNCTION	Peak (PK)
FREQUENCY RANGE	1GHz ~ 40GHz		Average (AV)

ANTENNA POLARITY & TEST DISTANCE: HORIZONTAL AT 3 M

NO.	FREQ. (MHz)	EMISSION LEVEL (dBuV/m)	LIMIT (dBuV/m)	MARGIN (dB)	ANTENNA HEIGHT (m)	TABLE ANGLE (Degree)	RAW VALUE (dBuV)	CORRECTION FACTOR (dB/m)
1	*5290.00	89.5 PK			1.01 H	30	86.2	3.3
2	*5290.00	79.0 AV			1.01 H	30	75.7	3.3
3	5350.00	55.5 PK	74.0	-18.5	1.01 H	30	52.0	3.5
4	5350.00	41.2 AV	54.0	-12.8	1.01 H	30	37.7	3.5
5	#10580.00	51.0 PK	74.0	-23.0	1.41 H	311	36.7	14.3
6	#10580.00	39.5 AV	54.0	-14.5	1.41 H	311	25.2	14.3
7	15870.00	50.9 PK	74.0	-23.1	1.50 H	154	35.9	15.0
8	15870.00	40.9 AV	54.0	-13.1	1.50 H	154	25.9	15.0

ANTENNA POLARITY & TEST DISTANCE: VERTICAL AT 3 M

NO.	FREQ. (MHz)	EMISSION LEVEL (dBuV/m)	LIMIT (dBuV/m)	MARGIN (dB)	ANTENNA HEIGHT (m)	TABLE ANGLE (Degree)	RAW VALUE (dBuV)	CORRECTION FACTOR (dB/m)
1	*5290.00	102.2 PK			2.92 V	48	98.9	3.3
2	*5290.00	91.7 AV			2.92 V	48	88.4	3.3
3	5350.00	73.9 PK	74.0	-0.1	2.92 V	48	70.4	3.5
4	5350.00	53.4 AV	54.0	-0.6	2.92 V	48	49.9	3.5
5	#10580.00	50.2 PK	74.0	-23.8	1.04 V	360	35.9	14.3
6	#10580.00	39.2 AV	54.0	-14.8	1.04 V	360	24.9	14.3
7	15870.00	51.5 PK	74.0	-22.5	1.13 V	360	36.5	15.0
8	15870.00	41.2 AV	54.0	-12.8	1.13 V	360	26.2	15.0

Remark:

1. Emission Level(dBuV/m) = Raw Value(dBuV) + Correction Factor(dB/m)
2. Correction Factor(dB/m) = Antenna Factor(dB/m) + Cable Factor(dB)
3. The other emission levels were very low against the limit.
4. Margin value = Emission Level – Limit value
5. " * ": Fundamental frequency.
6. " # ": The radiated frequency is out of the restricted band.

CHANNEL	TX Channel 106	DETECTOR FUNCTION	Peak (PK)
FREQUENCY RANGE	1GHz ~ 40GHz		Average (AV)

ANTENNA POLARITY & TEST DISTANCE: HORIZONTAL AT 3 M								
NO.	FREQ. (MHz)	EMISSION LEVEL (dBuV/m)	LIMIT (dBuV/m)	MARGIN (dB)	ANTENNA HEIGHT (m)	TABLE ANGLE (Degree)	RAW VALUE (dBuV)	CORRECTION FACTOR (dB/m)
1	#5466.00	55.8 PK	74.0	-18.2	1.08 H	21	52.1	3.7
2	#5466.00	41.5 AV	54.0	-12.5	1.08 H	21	37.8	3.7
3	*5530.00	90.5 PK			1.08 H	21	86.6	3.9
4	*5530.00	80.0 AV			1.08 H	21	76.1	3.9
5	#5725.00	55.2 PK	74.0	-18.8	1.08 H	21	51.0	4.2
6	#5725.00	41.4 AV	54.0	-12.6	1.08 H	21	37.2	4.2
7	11060.00	51.0 PK	74.0	-23.0	1.50 H	336	35.9	15.1
8	11060.00	39.5 AV	54.0	-14.5	1.50 H	336	24.4	15.1
9	#16590.00	51.4 PK	74.0	-22.6	1.47 H	157	33.7	17.7
10	#16590.00	41.1 AV	54.0	-12.9	1.47 H	157	23.4	17.7

ANTENNA POLARITY & TEST DISTANCE: VERTICAL AT 3 M								
NO.	FREQ. (MHz)	EMISSION LEVEL (dBuV/m)	LIMIT (dBuV/m)	MARGIN (dB)	ANTENNA HEIGHT (m)	TABLE ANGLE (Degree)	RAW VALUE (dBuV)	CORRECTION FACTOR (dB/m)
1	#5466.00	73.9 PK	74.0	-0.1	2.90 V	33	70.2	3.7
2	#5466.00	50.9 AV	54.0	-3.1	2.90 V	33	47.2	3.7
3	*5530.00	103.6 PK			2.94 V	40	99.7	3.9
4	*5530.00	93.2 AV			2.94 V	40	89.3	3.9
5	#5725.00	53.3 PK	74.0	-20.7	2.94 V	47	49.1	4.2
6	#5725.00	41.8 AV	54.0	-12.2	2.94 V	47	37.6	4.2
7	11060.00	50.6 PK	74.0	-23.4	1.11 V	360	35.5	15.1
8	11060.00	39.1 AV	54.0	-14.9	1.11 V	360	24.0	15.1
9	#16590.00	50.6 PK	74.0	-23.4	1.13 V	358	32.9	17.7
10	#16590.00	40.7 AV	54.0	-13.3	1.13 V	358	23.0	17.7

Remark:

1. Emission Level(dBuV/m) = Raw Value(dBuV) + Correction Factor(dB/m)
2. Correction Factor(dB/m) = Antenna Factor(dB/m) + Cable Factor(dB)
3. The other emission levels were very low against the limit.
4. Margin value = Emission Level – Limit value
5. " * ": Fundamental frequency.
6. " # ": The radiated frequency is out of the restricted band.

CHANNEL	TX Channel 122	DETECTOR FUNCTION	Peak (PK)
FREQUENCY RANGE	1GHz ~ 40GHz		Average (AV)

ANTENNA POLARITY & TEST DISTANCE: HORIZONTAL AT 3 M								
NO.	FREQ. (MHz)	EMISSION LEVEL (dBuV/m)	LIMIT (dBuV/m)	MARGIN (dB)	ANTENNA HEIGHT (m)	TABLE ANGLE (Degree)	RAW VALUE (dBuV)	CORRECTION FACTOR (dB/m)
1	*5610.00	98.1 PK			1.00 H	11	94.2	3.9
2	*5610.00	88.6 AV			1.00 H	11	84.7	3.9
3	#5730.00	55.3 PK	74.0	-18.7	1.00 H	11	51.1	4.2
4	#5730.00	41.2 AV	54.0	-12.8	1.00 H	11	37.0	4.2
5	11220.00	50.3 PK	74.0	-23.7	1.44 H	313	35.1	15.2
6	11220.00	38.9 AV	54.0	-15.1	1.44 H	313	23.7	15.2
7	#16830.00	50.8 PK	74.0	-23.2	1.46 H	157	32.3	18.5
8	#16830.00	40.8 AV	54.0	-13.2	1.46 H	157	22.3	18.5
ANTENNA POLARITY & TEST DISTANCE: VERTICAL AT 3 M								
NO.	FREQ. (MHz)	EMISSION LEVEL (dBuV/m)	LIMIT (dBuV/m)	MARGIN (dB)	ANTENNA HEIGHT (m)	TABLE ANGLE (Degree)	RAW VALUE (dBuV)	CORRECTION FACTOR (dB/m)
1	*5610.00	110.6 PK			3.30 V	137	106.7	3.9
2	*5610.00	101.1 AV			3.30 V	137	97.2	3.9
3	#5730.00	72.4 PK	74.0	-1.6	3.15 V	137	68.2	4.2
4	#5730.00	53.7 AV	54.0	-0.3	3.15 V	137	49.5	4.2
5	11220.00	49.6 PK	74.0	-24.4	1.02 V	359	34.4	15.2
6	11220.00	38.7 AV	54.0	-15.3	1.02 V	359	23.5	15.2
7	#16830.00	50.6 PK	74.0	-23.4	1.04 V	346	32.1	18.5
8	#16830.00	40.6 AV	54.0	-13.4	1.04 V	346	22.1	18.5

Remark:

1. Emission Level(dBuV/m) = Raw Value(dBuV) + Correction Factor(dB/m)
2. Correction Factor(dB/m) = Antenna Factor(dB/m) + Cable Factor(dB)
3. The other emission levels were very low against the limit.
4. Margin value = Emission Level – Limit value
5. " * ": Fundamental frequency.
6. " # ": The radiated frequency is out of the restricted band.

CHANNEL	TX Channel 138	DETECTOR FUNCTION	Peak (PK)
FREQUENCY RANGE	1GHz ~ 40GHz		Average (AV)

ANTENNA POLARITY & TEST DISTANCE: HORIZONTAL AT 3 M								
NO.	FREQ. (MHz)	EMISSION LEVEL (dBuV/m)	LIMIT (dBuV/m)	MARGIN (dB)	ANTENNA HEIGHT (m)	TABLE ANGLE (Degree)	RAW VALUE (dBuV)	CORRECTION FACTOR (dB/m)
1	#5470.00	55.2 PK	74.0	-18.8	1.09 H	12	51.5	3.7
2	#5470.00	40.9 AV	54.0	-13.1	1.09 H	12	37.2	3.7
3	*5690.00	99.3 PK			1.09 H	12	95.1	4.2
4	*5690.00	90.3 AV			1.09 H	12	86.1	4.2
5	#5850.00	55.1 PK	74.0	-18.9	1.09 H	12	50.9	4.2
6	#5850.00	41.0 AV	54.0	-13.0	1.09 H	12	36.8	4.2
7	11380.00	51.0 PK	74.0	-23.0	1.50 H	323	35.6	15.4
8	11380.00	39.4 AV	54.0	-14.6	1.50 H	323	24.0	15.4
9	#17070.00	51.6 PK	74.0	-22.4	1.46 H	151	31.6	20.0
10	#17070.00	41.4 AV	54.0	-12.6	1.46 H	151	21.4	20.0

ANTENNA POLARITY & TEST DISTANCE: VERTICAL AT 3 M								
NO.	FREQ. (MHz)	EMISSION LEVEL (dBuV/m)	LIMIT (dBuV/m)	MARGIN (dB)	ANTENNA HEIGHT (m)	TABLE ANGLE (Degree)	RAW VALUE (dBuV)	CORRECTION FACTOR (dB/m)
1	#5470.00	58.7 PK	74.0	-15.3	2.98 V	136	55.0	3.7
2	#5470.00	47.4 AV	54.0	-6.6	2.98 V	136	43.7	3.7
3	*5690.00	112.3 PK			2.98 V	136	108.1	4.2
4	*5690.00	103.3 AV			2.98 V	136	99.1	4.2
5	#5850.00	67.7 PK	74.0	-6.3	3.01 V	135	63.5	4.2
6	#5850.00	53.8 AV	54.0	-0.2	3.01 V	135	49.6	4.2
7	11380.00	50.1 PK	74.0	-23.9	1.02 V	360	34.7	15.4
8	11380.00	38.7 AV	54.0	-15.3	1.02 V	360	23.3	15.4
9	#17070.00	51.8 PK	74.0	-22.2	1.10 V	346	31.8	20.0
10	#17070.00	41.4 AV	54.0	-12.6	1.10 V	346	21.4	20.0

Remark:

1. Emission Level(dBuV/m) = Raw Value(dBuV) + Correction Factor(dB/m)
2. Correction Factor(dB/m) = Antenna Factor(dB/m) + Cable Factor(dB)
3. The other emission levels were very low against the limit.
4. Margin value = Emission Level – Limit value
5. " * " : Fundamental frequency.
6. " # " : The radiated frequency is out of the restricted band.

Radio 2 - 2TX with Dipole antenna CDD Mode

802.11a

CHANNEL	TX Channel 52	DETECTOR FUNCTION	Peak (PK)
FREQUENCY RANGE	1GHz ~ 40GHz		Average (AV)

ANTENNA POLARITY & TEST DISTANCE: HORIZONTAL AT 3 M								
NO.	FREQ. (MHz)	EMISSION LEVEL (dBuV/m)	LIMIT (dBuV/m)	MARGIN (dB)	ANTENNA HEIGHT (m)	TABLE ANGLE (Degree)	RAW VALUE (dBuV)	CORRECTION FACTOR (dB/m)
1	5100.00	55.3 PK	74.0	-18.7	2.97 H	357	52.5	2.8
2	5100.00	44.1 AV	54.0	-9.9	2.97 H	357	41.3	2.8
3	*5260.00	117.5 PK			2.97 H	357	114.2	3.3
4	*5260.00	108.4 AV			2.97 H	357	105.1	3.3
5	5420.00	57.1 PK	74.0	-16.9	2.96 H	360	53.4	3.7
6	5420.00	47.0 AV	54.0	-7.0	2.96 H	360	43.3	3.7
7	#10520.00	50.7 PK	74.0	-23.3	1.52 H	307	36.6	14.1
8	#10520.00	39.4 AV	54.0	-14.6	1.52 H	307	25.3	14.1
9	15780.00	51.2 PK	74.0	-22.8	1.40 H	145	36.0	15.2
10	15780.00	41.1 AV	54.0	-12.9	1.40 H	145	25.9	15.2

ANTENNA POLARITY & TEST DISTANCE: VERTICAL AT 3 M								
NO.	FREQ. (MHz)	EMISSION LEVEL (dBuV/m)	LIMIT (dBuV/m)	MARGIN (dB)	ANTENNA HEIGHT (m)	TABLE ANGLE (Degree)	RAW VALUE (dBuV)	CORRECTION FACTOR (dB/m)
1	5100.00	52.1 PK	74.0	-21.9	2.67 V	73	49.3	2.8
2	5100.00	40.9 AV	54.0	-13.1	2.67 V	73	38.1	2.8
3	*5260.00	104.8 PK			2.67 V	73	101.5	3.3
4	*5260.00	95.9 AV			2.67 V	73	92.6	3.3
5	5420.00	51.8 PK	74.0	-22.2	2.67 V	73	48.1	3.7
6	5420.00	40.6 AV	54.0	-13.4	2.67 V	73	36.9	3.7
7	#10520.00	49.9 PK	74.0	-24.1	1.07 V	360	35.8	14.1
8	#10520.00	38.9 AV	54.0	-15.1	1.07 V	360	24.8	14.1
9	15780.00	51.3 PK	74.0	-22.7	1.05 V	357	36.1	15.2
10	15780.00	41.2 AV	54.0	-12.8	1.05 V	357	26.0	15.2

Remark:

1. Emission Level(dBuV/m) = Raw Value(dBuV) + Correction Factor(dB/m)
2. Correction Factor(dB/m) = Antenna Factor(dB/m) + Cable Factor(dB)
3. The other emission levels were very low against the limit.
4. Margin value = Emission Level – Limit value
5. " * ": Fundamental frequency.
6. " # ": The radiated frequency is out of the restricted band.

CHANNEL	TX Channel 60	DETECTOR FUNCTION	Peak (PK)
FREQUENCY RANGE	1GHz ~ 40GHz		Average (AV)

ANTENNA POLARITY & TEST DISTANCE: HORIZONTAL AT 3 M								
NO.	FREQ. (MHz)	EMISSION LEVEL (dBuV/m)	LIMIT (dBuV/m)	MARGIN (dB)	ANTENNA HEIGHT (m)	TABLE ANGLE (Degree)	RAW VALUE (dBuV)	CORRECTION FACTOR (dB/m)
1	5140.00	55.3 PK	74.0	-18.7	2.96 H	360	52.3	3.0
2	5140.00	45.1 AV	54.0	-8.9	2.96 H	360	42.1	3.0
3	*5300.00	116.9 PK			2.96 H	360	113.6	3.3
4	*5300.00	108.5 AV			2.96 H	360	105.2	3.3
5	5350.00	61.9 PK	74.0	-12.1	2.96 H	178	58.4	3.5
6	5350.00	49.3 AV	54.0	-4.7	2.96 H	178	45.8	3.5
7	10600.00	50.2 PK	74.0	-23.8	1.46 H	319	35.9	14.3
8	10600.00	39.1 AV	54.0	-14.9	1.46 H	319	24.8	14.3
9	15900.00	51.5 PK	74.0	-22.5	1.36 H	138	36.4	15.1
10	15900.00	41.2 AV	54.0	-12.8	1.36 H	138	26.1	15.1

ANTENNA POLARITY & TEST DISTANCE: VERTICAL AT 3 M								
NO.	FREQ. (MHz)	EMISSION LEVEL (dBuV/m)	LIMIT (dBuV/m)	MARGIN (dB)	ANTENNA HEIGHT (m)	TABLE ANGLE (Degree)	RAW VALUE (dBuV)	CORRECTION FACTOR (dB/m)
1	5140.00	52.2 PK	74.0	-21.8	2.63 V	78	49.2	3.0
2	5140.00	40.7 AV	54.0	-13.3	2.63 V	78	37.7	3.0
3	*5300.00	104.0 PK			2.63 V	78	100.7	3.3
4	*5300.00	95.3 AV			2.63 V	78	92.0	3.3
5	5350.00	51.7 PK	74.0	-22.3	2.63 V	78	48.2	3.5
6	5350.00	40.6 AV	54.0	-13.4	2.63 V	78	37.1	3.5
7	10600.00	49.4 PK	74.0	-24.6	1.06 V	360	35.1	14.3
8	10600.00	38.5 AV	54.0	-15.5	1.06 V	360	24.2	14.3
9	15900.00	52.0 PK	74.0	-22.0	1.08 V	347	36.9	15.1
10	15900.00	41.7 AV	54.0	-12.3	1.08 V	347	26.6	15.1

Remark:

1. Emission Level(dBuV/m) = Raw Value(dBuV) + Correction Factor(dB/m)
2. Correction Factor(dB/m) = Antenna Factor(dB/m) + Cable Factor(dB)
3. The other emission levels were very low against the limit.
4. Margin value = Emission Level – Limit value
5. " * ": Fundamental frequency.
6. " # ": The radiated frequency is out of the restricted band.

CHANNEL	TX Channel 64	DETECTOR FUNCTION	Peak (PK)
FREQUENCY RANGE	1GHz ~ 40GHz		Average (AV)

ANTENNA POLARITY & TEST DISTANCE: HORIZONTAL AT 3 M								
NO.	FREQ. (MHz)	EMISSION LEVEL (dBuV/m)	LIMIT (dBuV/m)	MARGIN (dB)	ANTENNA HEIGHT (m)	TABLE ANGLE (Degree)	RAW VALUE (dBuV)	CORRECTION FACTOR (dB/m)
1	*5320.00	115.2 PK			2.96 H	180	111.7	3.5
2	*5320.00	106.6 AV			2.96 H	180	103.1	3.5
3	5350.00	66.4 PK	74.0	-7.6	2.44 H	181	62.9	3.5
4	5350.00	53.1 AV	54.0	-0.9	2.44 H	181	49.6	3.5
5	10640.00	50.9 PK	74.0	-23.1	1.57 H	312	36.6	14.3
6	10640.00	39.6 AV	54.0	-14.4	1.57 H	312	25.3	14.3
7	15960.00	51.1 PK	74.0	-22.9	1.36 H	155	36.0	15.1
8	15960.00	41.3 AV	54.0	-12.7	1.36 H	155	26.2	15.1
ANTENNA POLARITY & TEST DISTANCE: VERTICAL AT 3 M								
NO.	FREQ. (MHz)	EMISSION LEVEL (dBuV/m)	LIMIT (dBuV/m)	MARGIN (dB)	ANTENNA HEIGHT (m)	TABLE ANGLE (Degree)	RAW VALUE (dBuV)	CORRECTION FACTOR (dB/m)
1	*5320.00	101.8 PK			2.69 V	67	98.3	3.5
2	*5320.00	93.2 AV			2.69 V	67	89.7	3.5
3	5350.00	51.9 PK	74.0	-22.1	2.69 V	67	48.4	3.5
4	5350.00	40.4 AV	54.0	-13.6	2.69 V	67	36.9	3.5
5	10640.00	50.1 PK	74.0	-23.9	1.11 V	360	35.8	14.3
6	10640.00	39.1 AV	54.0	-14.9	1.11 V	360	24.8	14.3
7	15960.00	51.4 PK	74.0	-22.6	1.03 V	345	36.3	15.1
8	15960.00	41.1 AV	54.0	-12.9	1.03 V	345	26.0	15.1

Remark:

1. Emission Level(dBuV/m) = Raw Value(dBuV) + Correction Factor(dB/m)
2. Correction Factor(dB/m) = Antenna Factor(dB/m) + Cable Factor(dB)
3. The other emission levels were very low against the limit.
4. Margin value = Emission Level – Limit value
5. " * ": Fundamental frequency.
6. " # ": The radiated frequency is out of the restricted band.

CHANNEL	TX Channel 100	DETECTOR FUNCTION	Peak (PK)
FREQUENCY RANGE	1GHz ~ 40GHz		Average (AV)

ANTENNA POLARITY & TEST DISTANCE: HORIZONTAL AT 3 M

NO.	FREQ. (MHz)	EMISSION LEVEL (dBuV/m)	LIMIT (dBuV/m)	MARGIN (dB)	ANTENNA HEIGHT (m)	TABLE ANGLE (Degree)	RAW VALUE (dBuV)	CORRECTION FACTOR (dB/m)
1	#5470.00	66.1 PK	74.0	-7.9	2.82 H	178	62.4	3.7
2	#5470.00	51.4 AV	54.0	-2.6	2.82 H	178	47.7	3.7
3	*5500.00	113.9 PK			2.42 H	183	110.1	3.8
4	*5500.00	105.5 AV			2.42 H	183	101.7	3.8
5	#5730.00	64.3 PK	74.0	-9.7	3.63 H	360	60.1	4.2
6	#5730.00	53.8 AV	54.0	-0.2	3.63 H	360	49.6	4.2
7	11000.00	50.8 PK	74.0	-23.2	1.51 H	312	35.6	15.2
8	11000.00	39.3 AV	54.0	-14.7	1.51 H	312	24.1	15.2
9	#16500.00	51.4 PK	74.0	-22.6	1.44 H	142	34.0	17.4
10	#16500.00	41.5 AV	54.0	-12.5	1.44 H	142	24.1	17.4

ANTENNA POLARITY & TEST DISTANCE: VERTICAL AT 3 M

NO.	FREQ. (MHz)	EMISSION LEVEL (dBuV/m)	LIMIT (dBuV/m)	MARGIN (dB)	ANTENNA HEIGHT (m)	TABLE ANGLE (Degree)	RAW VALUE (dBuV)	CORRECTION FACTOR (dB/m)
1	#5470.00	52.9 PK	74.0	-21.1	2.65 V	72	49.2	3.7
2	#5470.00	41.4 AV	54.0	-12.6	2.65 V	72	37.7	3.7
3	*5500.00	100.7 PK			2.65 V	72	96.9	3.8
4	*5500.00	92.1 AV			2.65 V	72	88.3	3.8
5	#5730.00	52.9 PK	74.0	-21.1	2.65 V	72	48.7	4.2
6	#5730.00	41.4 AV	54.0	-12.6	2.65 V	72	37.2	4.2
7	11000.00	49.6 PK	74.0	-24.4	1.02 V	360	34.4	15.2
8	11000.00	38.7 AV	54.0	-15.3	1.02 V	360	23.5	15.2
9	#16500.00	51.2 PK	74.0	-22.8	1.06 V	360	33.8	17.4
10	#16500.00	41.1 AV	54.0	-12.9	1.06 V	360	23.7	17.4

Remark:

1. Emission Level(dBuV/m) = Raw Value(dBuV) + Correction Factor(dB/m)
2. Correction Factor(dB/m) = Antenna Factor(dB/m) + Cable Factor(dB)
3. The other emission levels were very low against the limit.
4. Margin value = Emission Level – Limit value
5. " * ": Fundamental frequency.
6. " # ": The radiated frequency is out of the restricted band.

CHANNEL	TX Channel 116	DETECTOR FUNCTION	Peak (PK)
FREQUENCY RANGE	1GHz ~ 40GHz		Average (AV)

ANTENNA POLARITY & TEST DISTANCE: HORIZONTAL AT 3 M

NO.	FREQ. (MHz)	EMISSION LEVEL (dBuV/m)	LIMIT (dBuV/m)	MARGIN (dB)	ANTENNA HEIGHT (m)	TABLE ANGLE (Degree)	RAW VALUE (dBuV)	CORRECTION FACTOR (dB/m)
1	5420.00	62.3 PK	74.0	-11.7	3.23 H	358	58.6	3.7
2	5420.00	53.2 AV	54.0	-0.8	3.23 H	358	49.5	3.7
3	*5580.00	114.7 PK			3.37 H	360	110.8	3.9
4	*5580.00	106.0 AV			3.37 H	360	102.1	3.9
5	#5730.00	62.4 PK	74.0	-11.6	3.65 H	358	58.2	4.2
6	#5730.00	52.9 AV	54.0	-1.1	3.65 H	358	48.7	4.2
7	11160.00	50.4 PK	74.0	-23.6	1.46 H	302	35.2	15.2
8	11160.00	39.2 AV	54.0	-14.8	1.46 H	302	24.0	15.2
9	#16740.00	50.8 PK	74.0	-23.2	1.42 H	148	32.5	18.3
10	#16740.00	40.6 AV	54.0	-13.4	1.42 H	148	22.3	18.3

ANTENNA POLARITY & TEST DISTANCE: VERTICAL AT 3 M

NO.	FREQ. (MHz)	EMISSION LEVEL (dBuV/m)	LIMIT (dBuV/m)	MARGIN (dB)	ANTENNA HEIGHT (m)	TABLE ANGLE (Degree)	RAW VALUE (dBuV)	CORRECTION FACTOR (dB/m)
1	5420.00	52.2 PK	74.0	-21.8	2.66 V	84	48.5	3.7
2	5420.00	40.8 AV	54.0	-13.2	2.66 V	84	37.1	3.7
3	*5580.00	101.5 PK			2.66 V	84	97.6	3.9
4	*5580.00	93.0 AV			2.66 V	84	89.1	3.9
5	#5730.00	52.0 PK	74.0	-22.0	2.66 V	84	47.8	4.2
6	#5730.00	41.1 AV	54.0	-12.9	2.66 V	84	36.9	4.2
7	11160.00	50.3 PK	74.0	-23.7	1.10 V	360	35.1	15.2
8	11160.00	39.3 AV	54.0	-14.7	1.10 V	360	24.1	15.2
9	#16740.00	51.7 PK	74.0	-22.3	1.05 V	360	33.4	18.3
10	#16740.00	41.5 AV	54.0	-12.5	1.05 V	360	23.2	18.3

Remark:

1. Emission Level(dBuV/m) = Raw Value(dBuV) + Correction Factor(dB/m)
2. Correction Factor(dB/m) = Antenna Factor(dB/m) + Cable Factor(dB)
3. The other emission levels were very low against the limit.
4. Margin value = Emission Level – Limit value
5. " * ": Fundamental frequency.
6. " # ": The radiated frequency is out of the restricted band.

CHANNEL	TX Channel 140	DETECTOR FUNCTION	Peak (PK)
FREQUENCY RANGE	1GHz ~ 40GHz		Average (AV)

ANTENNA POLARITY & TEST DISTANCE: HORIZONTAL AT 3 M								
NO.	FREQ. (MHz)	EMISSION LEVEL (dBuV/m)	LIMIT (dBuV/m)	MARGIN (dB)	ANTENNA HEIGHT (m)	TABLE ANGLE (Degree)	RAW VALUE (dBuV)	CORRECTION FACTOR (dB/m)
1	#5465.00	59.3 PK	74.0	-14.7	2.81 H	348	55.6	3.7
2	#5465.00	50.1 AV	54.0	-3.9	2.81 H	348	46.4	3.7
3	*5700.00	113.2 PK			3.39 H	357	109.0	4.2
4	*5700.00	104.6 AV			3.39 H	357	100.4	4.2
5	#5725.00	69.6 PK	74.0	-4.4	3.05 H	360	65.4	4.2
6	#5725.00	53.7 AV	54.0	-0.3	3.05 H	360	49.5	4.2
7	11400.00	51.0 PK	74.0	-23.0	1.49 H	300	35.5	15.5
8	11400.00	39.5 AV	54.0	-14.5	1.49 H	300	24.0	15.5
9	#17100.00	51.9 PK	74.0	-22.1	1.44 H	154	31.8	20.1
10	#17100.00	41.5 AV	54.0	-12.5	1.44 H	154	21.4	20.1

ANTENNA POLARITY & TEST DISTANCE: VERTICAL AT 3 M								
NO.	FREQ. (MHz)	EMISSION LEVEL (dBuV/m)	LIMIT (dBuV/m)	MARGIN (dB)	ANTENNA HEIGHT (m)	TABLE ANGLE (Degree)	RAW VALUE (dBuV)	CORRECTION FACTOR (dB/m)
1	#5465.00	51.6 PK	74.0	-22.4	2.70 V	65	47.9	3.7
2	#5465.00	40.4 AV	54.0	-13.6	2.70 V	65	36.7	3.7
3	*5700.00	100.4 PK			2.70 V	65	96.2	4.2
4	*5700.00	91.9 AV			2.70 V	65	87.7	4.2
5	#5725.00	52.5 PK	74.0	-21.5	2.70 V	65	48.3	4.2
6	#5725.00	41.4 AV	54.0	-12.6	2.70 V	65	37.2	4.2
7	11400.00	50.2 PK	74.0	-23.8	1.09 V	360	34.7	15.5
8	11400.00	39.4 AV	54.0	-14.6	1.09 V	360	23.9	15.5
9	#17100.00	51.4 PK	74.0	-22.6	1.00 V	358	31.3	20.1
10	#17100.00	41.2 AV	54.0	-12.8	1.00 V	358	21.1	20.1

Remark:

1. Emission Level(dBuV/m) = Raw Value(dBuV) + Correction Factor(dB/m)
2. Correction Factor(dB/m) = Antenna Factor(dB/m) + Cable Factor(dB)
3. The other emission levels were very low against the limit.
4. Margin value = Emission Level – Limit value
5. " * ": Fundamental frequency.
6. " # ": The radiated frequency is out of the restricted band.

CHANNEL	TX Channel 144	DETECTOR FUNCTION	Peak (PK)
FREQUENCY RANGE	1GHz ~ 40GHz		Average (AV)

ANTENNA POLARITY & TEST DISTANCE: HORIZONTAL AT 3 M

NO.	FREQ. (MHz)	EMISSION LEVEL (dBuV/m)	LIMIT (dBuV/m)	MARGIN (dB)	ANTENNA HEIGHT (m)	TABLE ANGLE (Degree)	RAW VALUE (dBuV)	CORRECTION FACTOR (dB/m)
1	5400.00	52.7 PK	74.0	-21.3	3.39 H	357	49.0	3.7
2	5400.00	41.8 AV	54.0	-12.2	3.39 H	357	38.1	3.7
3	*5720.00	115.8 PK			3.39 H	357	111.6	4.2
4	*5720.00	107.0 AV			3.39 H	357	102.8	4.2
5	#5880.00	60.3 PK	74.0	-13.7	3.38 H	332	56.1	4.2
6	#5880.00	50.3 AV	54.0	-3.7	3.38 H	332	46.1	4.2
7	11440.00	50.0 PK	74.0	-24.0	1.55 H	304	34.7	15.3
8	11440.00	38.9 AV	54.0	-15.1	1.55 H	304	23.6	15.3
9	#17160.00	50.9 PK	74.0	-23.1	1.44 H	134	31.1	19.8
10	#17160.00	40.9 AV	54.0	-13.1	1.44 H	134	21.1	19.8

ANTENNA POLARITY & TEST DISTANCE: VERTICAL AT 3 M

NO.	FREQ. (MHz)	EMISSION LEVEL (dBuV/m)	LIMIT (dBuV/m)	MARGIN (dB)	ANTENNA HEIGHT (m)	TABLE ANGLE (Degree)	RAW VALUE (dBuV)	CORRECTION FACTOR (dB/m)
1	5400.00	52.2 PK	74.0	-21.8	2.69 V	85	48.5	3.7
2	5400.00	41.3 AV	54.0	-12.7	2.69 V	85	37.6	3.7
3	*5720.00	102.8 PK			2.69 V	85	98.6	4.2
4	*5720.00	94.0 AV			2.69 V	85	89.8	4.2
5	#5880.00	52.1 PK	74.0	-21.9	2.69 V	85	47.9	4.2
6	#5880.00	40.9 AV	54.0	-13.1	2.69 V	85	36.7	4.2
7	11440.00	50.0 PK	74.0	-24.0	1.02 V	359	34.7	15.3
8	11440.00	38.7 AV	54.0	-15.3	1.02 V	359	23.4	15.3
9	#17160.00	52.0 PK	74.0	-22.0	1.02 V	348	32.2	19.8
10	#17160.00	41.6 AV	54.0	-12.4	1.02 V	348	21.8	19.8

Remark:

1. Emission Level(dBuV/m) = Raw Value(dBuV) + Correction Factor(dB/m)
2. Correction Factor(dB/m) = Antenna Factor(dB/m) + Cable Factor(dB)
3. The other emission levels were very low against the limit.
4. Margin value = Emission Level – Limit value
5. " * ": Fundamental frequency.
6. " # ": The radiated frequency is out of the restricted band.

802.11ac (VHT20)

CHANNEL	TX Channel 52	DETECTOR FUNCTION	Peak (PK)
FREQUENCY RANGE	1GHz ~ 40GHz		Average (AV)

ANTENNA POLARITY & TEST DISTANCE: HORIZONTAL AT 3 M								
NO.	FREQ. (MHz)	EMISSION LEVEL (dBuV/m)	LIMIT (dBuV/m)	MARGIN (dB)	ANTENNA HEIGHT (m)	TABLE ANGLE (Degree)	RAW VALUE (dBuV)	CORRECTION FACTOR (dB/m)
1	5100.00	54.1 PK	74.0	-19.9	2.78 H	360	51.3	2.8
2	5100.00	43.7 AV	54.0	-10.3	2.78 H	360	40.9	2.8
3	*5260.00	116.5 PK			2.78 H	360	113.2	3.3
4	*5260.00	107.6 AV			2.78 H	360	104.3	3.3
5	5420.00	55.9 PK	74.0	-18.1	2.78 H	360	52.2	3.7
6	5420.00	45.5 AV	54.0	-8.5	2.78 H	360	41.8	3.7
7	#10520.00	50.8 PK	74.0	-23.2	1.53 H	315	36.7	14.1
8	#10520.00	39.2 AV	54.0	-14.8	1.53 H	315	25.1	14.1
9	15780.00	51.4 PK	74.0	-22.6	1.40 H	147	36.2	15.2
10	15780.00	41.1 AV	54.0	-12.9	1.40 H	147	25.9	15.2
ANTENNA POLARITY & TEST DISTANCE: VERTICAL AT 3 M								
NO.	FREQ. (MHz)	EMISSION LEVEL (dBuV/m)	LIMIT (dBuV/m)	MARGIN (dB)	ANTENNA HEIGHT (m)	TABLE ANGLE (Degree)	RAW VALUE (dBuV)	CORRECTION FACTOR (dB/m)
1	5100.00	52.7 PK	74.0	-21.3	2.67 V	84	49.9	2.8
2	5100.00	41.3 AV	54.0	-12.7	2.67 V	84	38.5	2.8
3	*5260.00	103.0 PK			2.67 V	84	99.7	3.3
4	*5260.00	94.3 AV			2.67 V	84	91.0	3.3
5	5420.00	52.2 PK	74.0	-21.8	2.67 V	84	48.5	3.7
6	5420.00	40.9 AV	54.0	-13.1	2.67 V	84	37.2	3.7
7	#10520.00	50.1 PK	74.0	-23.9	1.03 V	360	36.0	14.1
8	#10520.00	38.8 AV	54.0	-15.2	1.03 V	360	24.7	14.1
9	15780.00	50.9 PK	74.0	-23.1	1.07 V	360	35.7	15.2
10	15780.00	41.0 AV	54.0	-13.0	1.07 V	360	25.8	15.2

Remark:

1. Emission Level(dBuV/m) = Raw Value(dBuV) + Correction Factor(dB/m)
2. Correction Factor(dB/m) = Antenna Factor(dB/m) + Cable Factor(dB)
3. The other emission levels were very low against the limit.
4. Margin value = Emission Level – Limit value
5. " * ": Fundamental frequency.
6. " # ": The radiated frequency is out of the restricted band.

CHANNEL	TX Channel 60	DETECTOR FUNCTION	Peak (PK)
FREQUENCY RANGE	1GHz ~ 40GHz		Average (AV)

ANTENNA POLARITY & TEST DISTANCE: HORIZONTAL AT 3 M

NO.	FREQ. (MHz)	EMISSION LEVEL (dBuV/m)	LIMIT (dBuV/m)	MARGIN (dB)	ANTENNA HEIGHT (m)	TABLE ANGLE (Degree)	RAW VALUE (dBuV)	CORRECTION FACTOR (dB/m)
1	5140.00	54.2 PK	74.0	-19.8	2.75 H	360	51.2	3.0
2	5140.00	43.9 AV	54.0	-10.1	2.75 H	360	40.9	3.0
3	*5300.00	116.2 PK			2.75 H	360	112.9	3.3
4	*5300.00	107.3 AV			2.75 H	360	104.0	3.3
5	5350.00	60.9 PK	74.0	-13.1	2.75 H	360	57.4	3.5
6	5350.00	49.0 AV	54.0	-5.0	2.75 H	360	45.5	3.5
7	10600.00	51.0 PK	74.0	-23.0	1.51 H	313	36.7	14.3
8	10600.00	39.6 AV	54.0	-14.4	1.51 H	313	25.3	14.3
9	15900.00	50.7 PK	74.0	-23.3	1.36 H	131	35.6	15.1
10	15900.00	40.7 AV	54.0	-13.3	1.36 H	131	25.6	15.1

ANTENNA POLARITY & TEST DISTANCE: VERTICAL AT 3 M

NO.	FREQ. (MHz)	EMISSION LEVEL (dBuV/m)	LIMIT (dBuV/m)	MARGIN (dB)	ANTENNA HEIGHT (m)	TABLE ANGLE (Degree)	RAW VALUE (dBuV)	CORRECTION FACTOR (dB/m)
1	5140.00	52.4 PK	74.0	-21.6	2.70 V	60	49.4	3.0
2	5140.00	41.2 AV	54.0	-12.8	2.70 V	60	38.2	3.0
3	*5300.00	103.4 PK			2.70 V	60	100.1	3.3
4	*5300.00	94.4 AV			2.70 V	60	91.1	3.3
5	5350.00	51.5 PK	74.0	-22.5	2.70 V	60	48.0	3.5
6	5350.00	40.5 AV	54.0	-13.5	2.70 V	60	37.0	3.5
7	10600.00	50.1 PK	74.0	-23.9	1.10 V	360	35.8	14.3
8	10600.00	39.2 AV	54.0	-14.8	1.10 V	360	24.9	14.3
9	15900.00	51.3 PK	74.0	-22.7	1.03 V	350	36.2	15.1
10	15900.00	41.1 AV	54.0	-12.9	1.03 V	350	26.0	15.1

Remark:

1. Emission Level(dBuV/m) = Raw Value(dBuV) + Correction Factor(dB/m)
2. Correction Factor(dB/m) = Antenna Factor(dB/m) + Cable Factor(dB)
3. The other emission levels were very low against the limit.
4. Margin value = Emission Level – Limit value
5. " * ": Fundamental frequency.
6. " # ": The radiated frequency is out of the restricted band.

CHANNEL	TX Channel 64	DETECTOR FUNCTION	Peak (PK)
FREQUENCY RANGE	1GHz ~ 40GHz		Average (AV)

ANTENNA POLARITY & TEST DISTANCE: HORIZONTAL AT 3 M								
NO.	FREQ. (MHz)	EMISSION LEVEL (dBuV/m)	LIMIT (dBuV/m)	MARGIN (dB)	ANTENNA HEIGHT (m)	TABLE ANGLE (Degree)	RAW VALUE (dBuV)	CORRECTION FACTOR (dB/m)
1	*5320.00	115.1 PK			2.79 H	360	111.6	3.5
2	*5320.00	107.6 AV			2.79 H	360	104.1	3.5
3	5350.00	71.0 PK	74.0	-3.0	2.79 H	360	67.5	3.5
4	5350.00	53.2 AV	54.0	-0.8	2.79 H	360	49.7	3.5
5	10640.00	50.4 PK	74.0	-23.6	1.55 H	297	36.1	14.3
6	10640.00	39.4 AV	54.0	-14.6	1.55 H	297	25.1	14.3
7	15960.00	50.6 PK	74.0	-23.4	1.37 H	130	35.5	15.1
8	15960.00	40.6 AV	54.0	-13.4	1.37 H	130	25.5	15.1
ANTENNA POLARITY & TEST DISTANCE: VERTICAL AT 3 M								
NO.	FREQ. (MHz)	EMISSION LEVEL (dBuV/m)	LIMIT (dBuV/m)	MARGIN (dB)	ANTENNA HEIGHT (m)	TABLE ANGLE (Degree)	RAW VALUE (dBuV)	CORRECTION FACTOR (dB/m)
1	*5320.00	101.7 PK			2.70 V	82	98.2	3.5
2	*5320.00	94.1 AV			2.70 V	82	90.6	3.5
3	5350.00	52.5 PK	74.0	-21.5	2.70 V	82	49.0	3.5
4	5350.00	41.3 AV	54.0	-12.7	2.70 V	82	37.8	3.5
5	10640.00	50.2 PK	74.0	-23.8	1.03 V	360	35.9	14.3
6	10640.00	39.3 AV	54.0	-14.7	1.03 V	360	25.0	14.3
7	15960.00	51.6 PK	74.0	-22.4	1.01 V	360	36.5	15.1
8	15960.00	41.6 AV	54.0	-12.4	1.01 V	360	26.5	15.1

Remark:

1. Emission Level(dBuV/m) = Raw Value(dBuV) + Correction Factor(dB/m)
2. Correction Factor(dB/m) = Antenna Factor(dB/m) + Cable Factor(dB)
3. The other emission levels were very low against the limit.
4. Margin value = Emission Level – Limit value
5. " * ": Fundamental frequency.
6. " # ": The radiated frequency is out of the restricted band.

CHANNEL	TX Channel 100	DETECTOR FUNCTION	Peak (PK)
FREQUENCY RANGE	1GHz ~ 40GHz		Average (AV)

ANTENNA POLARITY & TEST DISTANCE: HORIZONTAL AT 3 M

NO.	FREQ. (MHz)	EMISSION LEVEL (dBuV/m)	LIMIT (dBuV/m)	MARGIN (dB)	ANTENNA HEIGHT (m)	TABLE ANGLE (Degree)	RAW VALUE (dBuV)	CORRECTION FACTOR (dB/m)
1	#5470.00	70.9 PK	74.0	-3.1	2.72 H	360	67.2	3.7
2	#5470.00	53.2 AV	54.0	-0.8	2.72 H	360	49.5	3.7
3	*5500.00	115.1 PK			2.72 H	360	111.3	3.8
4	*5500.00	105.4 AV			2.72 H	360	101.6	3.8
5	11000.00	50.9 PK	74.0	-23.1	1.56 H	292	35.7	15.2
6	11000.00	39.4 AV	54.0	-14.6	1.56 H	292	24.2	15.2
7	#16500.00	51.1 PK	74.0	-22.9	1.38 H	135	33.7	17.4
8	#16500.00	41.1 AV	54.0	-12.9	1.38 H	135	23.7	17.4

ANTENNA POLARITY & TEST DISTANCE: VERTICAL AT 3 M

NO.	FREQ. (MHz)	EMISSION LEVEL (dBuV/m)	LIMIT (dBuV/m)	MARGIN (dB)	ANTENNA HEIGHT (m)	TABLE ANGLE (Degree)	RAW VALUE (dBuV)	CORRECTION FACTOR (dB/m)
1	#5470.00	52.8 PK	74.0	-21.2	2.71 V	60	49.1	3.7
2	#5470.00	41.3 AV	54.0	-12.7	2.71 V	60	37.6	3.7
3	*5500.00	101.9 PK			2.71 V	60	98.1	3.8
4	*5500.00	92.2 AV			2.71 V	60	88.4	3.8
5	11000.00	50.2 PK	74.0	-23.8	1.02 V	360	35.0	15.2
6	11000.00	39.1 AV	54.0	-14.9	1.02 V	360	23.9	15.2
7	#16500.00	51.8 PK	74.0	-22.2	1.10 V	360	34.4	17.4
8	#16500.00	41.6 AV	54.0	-12.4	1.10 V	360	24.2	17.4

Remark:

1. Emission Level(dBuV/m) = Raw Value(dBuV) + Correction Factor(dB/m)
2. Correction Factor(dB/m) = Antenna Factor(dB/m) + Cable Factor(dB)
3. The other emission levels were very low against the limit.
4. Margin value = Emission Level – Limit value
5. " * ": Fundamental frequency.
6. " # ": The radiated frequency is out of the restricted band.

CHANNEL	TX Channel 116	DETECTOR FUNCTION	Peak (PK)
FREQUENCY RANGE	1GHz ~ 40GHz		Average (AV)

ANTENNA POLARITY & TEST DISTANCE: HORIZONTAL AT 3 M

NO.	FREQ. (MHz)	EMISSION LEVEL (dBuV/m)	LIMIT (dBuV/m)	MARGIN (dB)	ANTENNA HEIGHT (m)	TABLE ANGLE (Degree)	RAW VALUE (dBuV)	CORRECTION FACTOR (dB/m)
1	#5343.00	62.3 PK	74.0	-11.7	2.90 H	188	58.8	3.5
2	#5343.00	52.6 AV	54.0	-1.4	2.90 H	188	49.1	3.5
3	5420.00	62.6 PK	74.0	-11.4	2.71 H	183	58.9	3.7
4	5420.00	53.6 AV	54.0	-0.4	2.71 H	183	49.9	3.7
5	*5580.00	115.2 PK			3.17 H	360	111.3	3.9
6	*5580.00	106.4 AV			3.17 H	360	102.5	3.9
7	#5730.00	63.1 PK	74.0	-10.9	3.30 H	360	58.9	4.2
8	#5730.00	53.5 AV	54.0	-0.5	3.30 H	360	49.3	4.2
9	11160.00	50.7 PK	74.0	-23.3	1.53 H	317	35.5	15.2
10	11160.00	39.6 AV	54.0	-14.4	1.53 H	317	24.4	15.2
11	#16740.00	51.9 PK	74.0	-22.1	1.40 H	147	33.6	18.3
12	#16740.00	41.6 AV	54.0	-12.4	1.40 H	147	23.3	18.3

ANTENNA POLARITY & TEST DISTANCE: VERTICAL AT 3 M

NO.	FREQ. (MHz)	EMISSION LEVEL (dBuV/m)	LIMIT (dBuV/m)	MARGIN (dB)	ANTENNA HEIGHT (m)	TABLE ANGLE (Degree)	RAW VALUE (dBuV)	CORRECTION FACTOR (dB/m)
1	#5343.00	52.5 PK	74.0	-21.5	2.62 V	84	49.0	3.5
2	#5343.00	41.0 AV	54.0	-13.0	2.62 V	84	37.5	3.5
3	5420.00	52.6 PK	74.0	-21.4	2.62 V	84	48.9	3.7
4	5420.00	41.5 AV	54.0	-12.5	2.62 V	84	37.8	3.7
5	*5580.00	102.4 PK			2.62 V	84	98.5	3.9
6	*5580.00	93.6 AV			2.62 V	84	89.7	3.9
7	#5730.00	52.1 PK	74.0	-21.9	2.62 V	84	47.9	4.2
8	#5730.00	40.8 AV	54.0	-13.2	2.62 V	84	36.6	4.2
9	11160.00	49.7 PK	74.0	-24.3	1.13 V	360	34.5	15.2
10	11160.00	38.5 AV	54.0	-15.5	1.13 V	360	23.3	15.2
11	#16740.00	51.1 PK	74.0	-22.9	1.11 V	345	32.8	18.3
12	#16740.00	41.2 AV	54.0	-12.8	1.11 V	345	22.9	18.3

Remark:

1. Emission Level(dBuV/m) = Raw Value(dBuV) + Correction Factor(dB/m)
2. Correction Factor(dB/m) = Antenna Factor(dB/m) + Cable Factor(dB)
3. The other emission levels were very low against the limit.
4. Margin value = Emission Level – Limit value
5. " * ": Fundamental frequency.
6. " # ": The radiated frequency is out of the restricted band.

CHANNEL	TX Channel 140	DETECTOR FUNCTION	Peak (PK)
FREQUENCY RANGE	1GHz ~ 40GHz		Average (AV)

ANTENNA POLARITY & TEST DISTANCE: HORIZONTAL AT 3 M

NO.	FREQ. (MHz)	EMISSION LEVEL (dBuV/m)	LIMIT (dBuV/m)	MARGIN (dB)	ANTENNA HEIGHT (m)	TABLE ANGLE (Degree)	RAW VALUE (dBuV)	CORRECTION FACTOR (dB/m)
1	5460.00	58.3 PK	74.0	-15.7	2.57 H	297	54.6	3.7
2	5460.00	49.1 AV	54.0	-4.9	2.57 H	297	45.4	3.7
3	*5700.00	110.5 PK			2.59 H	275	106.3	4.2
4	*5700.00	101.3 AV			2.59 H	275	97.1	4.2
5	#5725.00	65.4 PK	74.0	-8.6	2.65 H	360	61.2	4.2
6	#5725.00	53.4 AV	54.0	-0.6	2.65 H	360	49.2	4.2
7	11400.00	50.3 PK	74.0	-23.7	1.50 H	317	34.8	15.5
8	11400.00	38.9 AV	54.0	-15.1	1.50 H	317	23.4	15.5
9	#17100.00	50.5 PK	74.0	-23.5	1.38 H	132	30.4	20.1
10	#17100.00	40.6 AV	54.0	-13.4	1.38 H	132	20.5	20.1

ANTENNA POLARITY & TEST DISTANCE: VERTICAL AT 3 M

NO.	FREQ. (MHz)	EMISSION LEVEL (dBuV/m)	LIMIT (dBuV/m)	MARGIN (dB)	ANTENNA HEIGHT (m)	TABLE ANGLE (Degree)	RAW VALUE (dBuV)	CORRECTION FACTOR (dB/m)
1	5460.00	51.9 PK	74.0	-22.1	2.62 V	85	48.2	3.7
2	5460.00	40.5 AV	54.0	-13.5	2.62 V	85	36.8	3.7
3	*5700.00	97.5 PK			2.62 V	85	93.3	4.2
4	*5700.00	88.5 AV			2.62 V	85	84.3	4.2
5	#5725.00	51.9 PK	74.0	-22.1	2.62 V	85	47.7	4.2
6	#5725.00	40.4 AV	54.0	-13.6	2.62 V	85	36.2	4.2
7	11400.00	49.5 PK	74.0	-24.5	1.02 V	360	34.0	15.5
8	11400.00	38.5 AV	54.0	-15.5	1.02 V	360	23.0	15.5
9	#17100.00	51.8 PK	74.0	-22.2	1.09 V	360	31.7	20.1
10	#17100.00	41.5 AV	54.0	-12.5	1.09 V	360	21.4	20.1

Remark:

1. Emission Level(dBuV/m) = Raw Value(dBuV) + Correction Factor(dB/m)
2. Correction Factor(dB/m) = Antenna Factor(dB/m) + Cable Factor(dB)
3. The other emission levels were very low against the limit.
4. Margin value = Emission Level – Limit value
5. " * ": Fundamental frequency.
6. " # ": The radiated frequency is out of the restricted band.

CHANNEL	TX Channel 144	DETECTOR FUNCTION	Peak (PK)
FREQUENCY RANGE	1GHz ~ 40GHz		Average (AV)

ANTENNA POLARITY & TEST DISTANCE: HORIZONTAL AT 3 M								
NO.	FREQ. (MHz)	EMISSION LEVEL (dBuV/m)	LIMIT (dBuV/m)	MARGIN (dB)	ANTENNA HEIGHT (m)	TABLE ANGLE (Degree)	RAW VALUE (dBuV)	CORRECTION FACTOR (dB/m)
1	5400.00	52.2 PK	74.0	-21.8	2.50 H	284	48.5	3.7
2	5400.00	41.5 AV	54.0	-12.5	2.50 H	284	37.8	3.7
3	*5720.00	112.9 PK			2.50 H	284	108.7	4.2
4	*5720.00	103.9 AV			2.50 H	284	99.7	4.2
5	#5880.00	59.2 PK	74.0	-14.8	2.50 H	113	55.0	4.2
6	#5880.00	50.2 AV	54.0	-3.8	2.50 H	113	46.0	4.2
7	11440.00	51.2 PK	74.0	-22.8	1.49 H	294	35.9	15.3
8	11440.00	39.7 AV	54.0	-14.3	1.49 H	294	24.4	15.3
9	#17160.00	51.3 PK	74.0	-22.7	1.36 H	156	31.5	19.8
10	#17160.00	41.1 AV	54.0	-12.9	1.36 H	156	21.3	19.8

ANTENNA POLARITY & TEST DISTANCE: VERTICAL AT 3 M								
NO.	FREQ. (MHz)	EMISSION LEVEL (dBuV/m)	LIMIT (dBuV/m)	MARGIN (dB)	ANTENNA HEIGHT (m)	TABLE ANGLE (Degree)	RAW VALUE (dBuV)	CORRECTION FACTOR (dB/m)
1	5400.00	52.1 PK	74.0	-21.9	2.73 V	72	48.4	3.7
2	5400.00	41.0 AV	54.0	-13.0	2.73 V	72	37.3	3.7
3	*5720.00	100.0 PK			2.73 V	72	95.8	4.2
4	*5720.00	91.2 AV			2.73 V	72	87.0	4.2
5	#5880.00	52.1 PK	74.0	-21.9	2.73 V	72	47.9	4.2
6	#5880.00	40.7 AV	54.0	-13.3	2.73 V	72	36.5	4.2
7	11440.00	49.7 PK	74.0	-24.3	1.02 V	360	34.4	15.3
8	11440.00	38.8 AV	54.0	-15.2	1.02 V	360	23.5	15.3
9	#17160.00	51.2 PK	74.0	-22.8	1.08 V	358	31.4	19.8
10	#17160.00	41.1 AV	54.0	-12.9	1.08 V	358	21.3	19.8

Remark:

1. Emission Level(dBuV/m) = Raw Value(dBuV) + Correction Factor(dB/m)
2. Correction Factor(dB/m) = Antenna Factor(dB/m) + Cable Factor(dB)
3. The other emission levels were very low against the limit.
4. Margin value = Emission Level – Limit value
5. " * " : Fundamental frequency.
6. " # " : The radiated frequency is out of the restricted band.

802.11ac (VHT40)

CHANNEL	TX Channel 54	DETECTOR FUNCTION	Peak (PK)
FREQUENCY RANGE	1GHz ~ 40GHz		Average (AV)

ANTENNA POLARITY & TEST DISTANCE: HORIZONTAL AT 3 M

NO.	FREQ. (MHz)	EMISSION LEVEL (dBuV/m)	LIMIT (dBuV/m)	MARGIN (dB)	ANTENNA HEIGHT (m)	TABLE ANGLE (Degree)	RAW VALUE (dBuV)	CORRECTION FACTOR (dB/m)
1	5090.00	59.8 PK	74.0	-14.2	2.89 H	168	57.0	2.8
2	5090.00	49.4 AV	54.0	-4.6	2.89 H	168	46.6	2.8
3	*5270.00	112.9 PK			2.39 H	185	109.6	3.3
4	*5270.00	104.2 AV			2.39 H	185	100.9	3.3
5	5430.00	64.7 PK	74.0	-9.3	3.06 H	186	61.0	3.7
6	5430.00	53.3 AV	54.0	-0.7	3.06 H	186	49.6	3.7
7	#10540.00	51.2 PK	74.0	-22.8	1.48 H	312	37.0	14.2
8	#10540.00	39.6 AV	54.0	-14.4	1.48 H	312	25.4	14.2
9	15810.00	51.4 PK	74.0	-22.6	1.34 H	158	36.4	15.0
10	15810.00	41.4 AV	54.0	-12.6	1.34 H	158	26.4	15.0

ANTENNA POLARITY & TEST DISTANCE: VERTICAL AT 3 M

NO.	FREQ. (MHz)	EMISSION LEVEL (dBuV/m)	LIMIT (dBuV/m)	MARGIN (dB)	ANTENNA HEIGHT (m)	TABLE ANGLE (Degree)	RAW VALUE (dBuV)	CORRECTION FACTOR (dB/m)
1	5090.00	51.6 PK	74.0	-22.4	2.63 V	69	48.8	2.8
2	5090.00	40.3 AV	54.0	-13.7	2.63 V	69	37.5	2.8
3	*5270.00	99.8 PK			2.63 V	69	96.5	3.3
4	*5270.00	91.0 AV			2.63 V	69	87.7	3.3
5	5430.00	52.1 PK	74.0	-21.9	2.63 V	69	48.4	3.7
6	5430.00	40.7 AV	54.0	-13.3	2.63 V	69	37.0	3.7
7	#10540.00	50.2 PK	74.0	-23.8	1.11 V	360	36.0	14.2
8	#10540.00	39.0 AV	54.0	-15.0	1.11 V	360	24.8	14.2
9	15810.00	51.8 PK	74.0	-22.2	1.00 V	360	36.8	15.0
10	15810.00	41.6 AV	54.0	-12.4	1.00 V	360	26.6	15.0

Remark:

1. Emission Level(dBuV/m) = Raw Value(dBuV) + Correction Factor(dB/m)
2. Correction Factor(dB/m) = Antenna Factor(dB/m) + Cable Factor(dB)
3. The other emission levels were very low against the limit.
4. Margin value = Emission Level – Limit value
5. " * ": Fundamental frequency.
6. " # ": The radiated frequency is out of the restricted band.

CHANNEL	TX Channel 62	DETECTOR FUNCTION	Peak (PK)
FREQUENCY RANGE	1GHz ~ 40GHz		Average (AV)

ANTENNA POLARITY & TEST DISTANCE: HORIZONTAL AT 3 M								
NO.	FREQ. (MHz)	EMISSION LEVEL (dBuV/m)	LIMIT (dBuV/m)	MARGIN (dB)	ANTENNA HEIGHT (m)	TABLE ANGLE (Degree)	RAW VALUE (dBuV)	CORRECTION FACTOR (dB/m)
1	*5310.00	108.7 PK			3.06 H	183	105.3	3.4
2	*5310.00	99.4 AV			3.06 H	183	96.0	3.4
3	5350.00	72.0 PK	74.0	-2.0	3.06 H	183	68.5	3.5
4	5350.00	53.6 AV	54.0	-0.4	3.06 H	183	50.1	3.5
5	10620.00	50.9 PK	74.0	-23.1	1.53 H	303	36.6	14.3
6	10620.00	39.3 AV	54.0	-14.7	1.53 H	303	25.0	14.3
7	15930.00	50.8 PK	74.0	-23.2	1.41 H	139	35.7	15.1
8	15930.00	40.9 AV	54.0	-13.1	1.41 H	139	25.8	15.1
ANTENNA POLARITY & TEST DISTANCE: VERTICAL AT 3 M								
NO.	FREQ. (MHz)	EMISSION LEVEL (dBuV/m)	LIMIT (dBuV/m)	MARGIN (dB)	ANTENNA HEIGHT (m)	TABLE ANGLE (Degree)	RAW VALUE (dBuV)	CORRECTION FACTOR (dB/m)
1	*5310.00	94.9 PK			2.58 V	62	91.5	3.4
2	*5310.00	85.9 AV			2.58 V	62	82.5	3.4
3	5350.00	51.9 PK	74.0	-22.1	2.58 V	62	48.4	3.5
4	5350.00	40.4 AV	54.0	-13.6	2.58 V	62	36.9	3.5
5	10620.00	50.2 PK	74.0	-23.8	1.13 V	360	35.9	14.3
6	10620.00	39.1 AV	54.0	-14.9	1.13 V	360	24.8	14.3
7	15930.00	51.5 PK	74.0	-22.5	1.04 V	344	36.4	15.1
8	15930.00	41.2 AV	54.0	-12.8	1.04 V	344	26.1	15.1

Remark:

1. Emission Level(dBuV/m) = Raw Value(dBuV) + Correction Factor(dB/m)
2. Correction Factor(dB/m) = Antenna Factor(dB/m) + Cable Factor(dB)
3. The other emission levels were very low against the limit.
4. Margin value = Emission Level – Limit value
5. " * ": Fundamental frequency.
6. " # ": The radiated frequency is out of the restricted band.

CHANNEL	TX Channel 102	DETECTOR FUNCTION	Peak (PK)
FREQUENCY RANGE	1GHz ~ 40GHz		Average (AV)

ANTENNA POLARITY & TEST DISTANCE: HORIZONTAL AT 3 M								
NO.	FREQ. (MHz)	EMISSION LEVEL (dBuV/m)	LIMIT (dBuV/m)	MARGIN (dB)	ANTENNA HEIGHT (m)	TABLE ANGLE (Degree)	RAW VALUE (dBuV)	CORRECTION FACTOR (dB/m)
1	#5466.00	69.2 PK	74.0	-4.8	2.86 H	182	65.5	3.7
2	#5466.00	53.6 AV	54.0	-0.4	2.86 H	182	49.9	3.7
3	*5510.00	108.9 PK			2.86 H	182	105.1	3.8
4	*5510.00	98.7 AV			2.86 H	182	94.9	3.8
5	11020.00	51.3 PK	74.0	-22.7	1.49 H	318	36.2	15.1
6	11020.00	39.8 AV	54.0	-14.2	1.49 H	318	24.7	15.1
7	#16530.00	50.9 PK	74.0	-23.1	1.36 H	138	33.4	17.5
8	#16530.00	40.8 AV	54.0	-13.2	1.36 H	138	23.3	17.5
ANTENNA POLARITY & TEST DISTANCE: VERTICAL AT 3 M								
NO.	FREQ. (MHz)	EMISSION LEVEL (dBuV/m)	LIMIT (dBuV/m)	MARGIN (dB)	ANTENNA HEIGHT (m)	TABLE ANGLE (Degree)	RAW VALUE (dBuV)	CORRECTION FACTOR (dB/m)
1	#5466.00	52.3 PK	74.0	-21.7	2.62 V	69	48.6	3.7
2	#5466.00	41.2 AV	54.0	-12.8	2.62 V	69	37.5	3.7
3	*5510.00	95.5 PK			2.62 V	69	91.7	3.8
4	*5510.00	85.4 AV			2.62 V	69	81.6	3.8
5	11020.00	49.5 PK	74.0	-24.5	1.05 V	360	34.4	15.1
6	11020.00	38.6 AV	54.0	-15.4	1.05 V	360	23.5	15.1
7	#16530.00	50.7 PK	74.0	-23.3	1.06 V	360	33.2	17.5
8	#16530.00	40.8 AV	54.0	-13.2	1.06 V	360	23.3	17.5

Remark:

1. Emission Level(dBuV/m) = Raw Value(dBuV) + Correction Factor(dB/m)
2. Correction Factor(dB/m) = Antenna Factor(dB/m) + Cable Factor(dB)
3. The other emission levels were very low against the limit.
4. Margin value = Emission Level – Limit value
5. " * ": Fundamental frequency.
6. " # ": The radiated frequency is out of the restricted band.

CHANNEL	TX Channel 110	DETECTOR FUNCTION	Peak (PK)
FREQUENCY RANGE	1GHz ~ 40GHz		Average (AV)

ANTENNA POLARITY & TEST DISTANCE: HORIZONTAL AT 3 M

NO.	FREQ. (MHz)	EMISSION LEVEL (dBuV/m)	LIMIT (dBuV/m)	MARGIN (dB)	ANTENNA HEIGHT (m)	TABLE ANGLE (Degree)	RAW VALUE (dBuV)	CORRECTION FACTOR (dB/m)
1	5390.00	60.5 PK	74.0	-13.5	2.60 H	175	56.8	3.7
2	5390.00	51.5 AV	54.0	-2.5	2.60 H	175	47.8	3.7
3	*5550.00	113.0 PK			2.61 H	183	109.1	3.9
4	*5550.00	103.5 AV			2.61 H	183	99.6	3.9
5	#5725.00	59.6 PK	74.0	-14.4	2.38 H	196	55.4	4.2
6	#5725.00	49.4 AV	54.0	-4.6	2.38 H	196	45.2	4.2
7	11100.00	50.6 PK	74.0	-23.4	1.55 H	293	35.5	15.1
8	11100.00	39.6 AV	54.0	-14.4	1.55 H	293	24.5	15.1
9	#16650.00	51.3 PK	74.0	-22.7	1.38 H	138	33.3	18.0
10	#16650.00	41.0 AV	54.0	-13.0	1.38 H	138	23.0	18.0

ANTENNA POLARITY & TEST DISTANCE: VERTICAL AT 3 M

NO.	FREQ. (MHz)	EMISSION LEVEL (dBuV/m)	LIMIT (dBuV/m)	MARGIN (dB)	ANTENNA HEIGHT (m)	TABLE ANGLE (Degree)	RAW VALUE (dBuV)	CORRECTION FACTOR (dB/m)
1	5390.00	51.6 PK	74.0	-22.4	2.61 V	63	47.9	3.7
2	5390.00	40.5 AV	54.0	-13.5	2.61 V	63	36.8	3.7
3	*5550.00	99.5 PK			2.61 V	63	95.6	3.9
4	*5550.00	90.2 AV			2.61 V	63	86.3	3.9
5	#5725.00	52.4 PK	74.0	-21.6	2.61 V	63	48.2	4.2
6	#5725.00	40.9 AV	54.0	-13.1	2.61 V	63	36.7	4.2
7	11100.00	50.0 PK	74.0	-24.0	1.07 V	356	34.9	15.1
8	11100.00	38.8 AV	54.0	-15.2	1.07 V	356	23.7	15.1
9	#16650.00	51.1 PK	74.0	-22.9	1.02 V	343	33.1	18.0
10	#16650.00	41.0 AV	54.0	-13.0	1.02 V	343	23.0	18.0

Remark:

1. Emission Level(dBuV/m) = Raw Value(dBuV) + Correction Factor(dB/m)
2. Correction Factor(dB/m) = Antenna Factor(dB/m) + Cable Factor(dB)
3. The other emission levels were very low against the limit.
4. Margin value = Emission Level – Limit value
5. " * ": Fundamental frequency.
6. " # ": The radiated frequency is out of the restricted band.

CHANNEL	TX Channel 134	DETECTOR FUNCTION	Peak (PK)
FREQUENCY RANGE	1GHz ~ 40GHz		Average (AV)

ANTENNA POLARITY & TEST DISTANCE: HORIZONTAL AT 3 M								
NO.	FREQ. (MHz)	EMISSION LEVEL (dBuV/m)	LIMIT (dBuV/m)	MARGIN (dB)	ANTENNA HEIGHT (m)	TABLE ANGLE (Degree)	RAW VALUE (dBuV)	CORRECTION FACTOR (dB/m)
1	5430.00	57.9 PK	74.0	-16.1	2.51 H	183	54.2	3.7
2	5430.00	47.5 AV	54.0	-6.5	2.51 H	183	43.8	3.7
3	*5670.00	111.6 PK			2.48 H	199	107.6	4.0
4	*5670.00	101.4 AV			2.48 H	199	97.4	4.0
5	#5728.00	72.8 PK	74.0	-1.2	2.61 H	183	68.6	4.2
6	#5728.00	53.7 AV	54.0	-0.3	2.61 H	183	49.5	4.2
7	11340.00	50.5 PK	74.0	-23.5	1.47 H	317	35.2	15.3
8	11340.00	39.4 AV	54.0	-14.6	1.47 H	317	24.1	15.3
9	#17010.00	51.7 PK	74.0	-22.3	1.34 H	135	31.8	19.9
10	#17010.00	41.4 AV	54.0	-12.6	1.34 H	135	21.5	19.9

ANTENNA POLARITY & TEST DISTANCE: VERTICAL AT 3 M								
NO.	FREQ. (MHz)	EMISSION LEVEL (dBuV/m)	LIMIT (dBuV/m)	MARGIN (dB)	ANTENNA HEIGHT (m)	TABLE ANGLE (Degree)	RAW VALUE (dBuV)	CORRECTION FACTOR (dB/m)
1	5430.00	52.0 PK	74.0	-22.0	2.65 V	74	48.3	3.7
2	5430.00	40.8 AV	54.0	-13.2	2.65 V	74	37.1	3.7
3	*5670.00	98.9 PK			2.65 V	74	94.9	4.0
4	*5670.00	88.6 AV			2.65 V	74	84.6	4.0
5	#5728.00	51.8 PK	74.0	-22.2	2.65 V	74	47.6	4.2
6	#5728.00	40.7 AV	54.0	-13.3	2.65 V	74	36.5	4.2
7	11340.00	49.8 PK	74.0	-24.2	1.08 V	360	34.5	15.3
8	11340.00	39.1 AV	54.0	-14.9	1.08 V	360	23.8	15.3
9	#17010.00	51.6 PK	74.0	-22.4	1.07 V	348	31.7	19.9
10	#17010.00	41.6 AV	54.0	-12.4	1.07 V	348	21.7	19.9

Remark:

1. Emission Level(dBuV/m) = Raw Value(dBuV) + Correction Factor(dB/m)
2. Correction Factor(dB/m) = Antenna Factor(dB/m) + Cable Factor(dB)
3. The other emission levels were very low against the limit.
4. Margin value = Emission Level – Limit value
5. " * ": Fundamental frequency.
6. " # ": The radiated frequency is out of the restricted band.

CHANNEL	TX Channel 142	DETECTOR FUNCTION	Peak (PK)
FREQUENCY RANGE	1GHz ~ 40GHz		Average (AV)

ANTENNA POLARITY & TEST DISTANCE: HORIZONTAL AT 3 M								
NO.	FREQ. (MHz)	EMISSION LEVEL (dBuV/m)	LIMIT (dBuV/m)	MARGIN (dB)	ANTENNA HEIGHT (m)	TABLE ANGLE (Degree)	RAW VALUE (dBuV)	CORRECTION FACTOR (dB/m)
1	#5470.00	56.3 PK	74.0	-17.7	2.87 H	133	52.6	3.7
2	#5470.00	46.8 AV	54.0	-7.2	2.87 H	133	43.1	3.7
3	*5710.00	112.6 PK			2.43 H	134	108.4	4.2
4	*5710.00	102.8 AV			2.43 H	134	98.6	4.2
5	#5850.00	56.6 PK	74.0	-17.4	2.87 H	133	52.4	4.2
6	#5850.00	46.9 AV	54.0	-7.1	2.87 H	133	42.7	4.2
7	11420.00	51.1 PK	74.0	-22.9	1.56 H	301	35.7	15.4
8	11420.00	39.6 AV	54.0	-14.4	1.56 H	301	24.2	15.4
9	#17130.00	51.0 PK	74.0	-23.0	1.42 H	151	31.0	20.0
10	#17130.00	40.9 AV	54.0	-13.1	1.42 H	151	20.9	20.0

ANTENNA POLARITY & TEST DISTANCE: VERTICAL AT 3 M								
NO.	FREQ. (MHz)	EMISSION LEVEL (dBuV/m)	LIMIT (dBuV/m)	MARGIN (dB)	ANTENNA HEIGHT (m)	TABLE ANGLE (Degree)	RAW VALUE (dBuV)	CORRECTION FACTOR (dB/m)
1	#5470.00	51.8 PK	74.0	-22.2	2.63 V	84	48.1	3.7
2	#5470.00	40.9 AV	54.0	-13.1	2.63 V	84	37.2	3.7
3	*5710.00	99.9 PK			2.63 V	84	95.7	4.2
4	*5710.00	90.0 AV			2.63 V	84	85.8	4.2
5	#5850.00	52.1 PK	74.0	-21.9	2.63 V	84	47.9	4.2
6	#5850.00	41.1 AV	54.0	-12.9	2.63 V	84	36.9	4.2
7	11420.00	49.4 PK	74.0	-24.6	1.01 V	356	34.0	15.4
8	11420.00	38.6 AV	54.0	-15.4	1.01 V	356	23.2	15.4
9	#17130.00	51.0 PK	74.0	-23.0	1.08 V	360	31.0	20.0
10	#17130.00	40.9 AV	54.0	-13.1	1.08 V	360	20.9	20.0

Remark:

1. Emission Level(dBuV/m) = Raw Value(dBuV) + Correction Factor(dB/m)
2. Correction Factor(dB/m) = Antenna Factor(dB/m) + Cable Factor(dB)
3. The other emission levels were very low against the limit.
4. Margin value = Emission Level – Limit value
5. " * ": Fundamental frequency.
6. " # ": The radiated frequency is out of the restricted band.

802.11ac (VHT80)

CHANNEL	TX Channel 58	DETECTOR FUNCTION	Peak (PK)
FREQUENCY RANGE	1GHz ~ 40GHz		Average (AV)

ANTENNA POLARITY & TEST DISTANCE: HORIZONTAL AT 3 M

NO.	FREQ. (MHz)	EMISSION LEVEL (dBuV/m)	LIMIT (dBuV/m)	MARGIN (dB)	ANTENNA HEIGHT (m)	TABLE ANGLE (Degree)	RAW VALUE (dBuV)	CORRECTION FACTOR (dB/m)
1	*5290.00	102.6 PK			2.90 H	57	99.3	3.3
2	*5290.00	92.0 AV			2.90 H	57	88.7	3.3
3	5350.00	73.8 PK	74.0	-0.2	2.97 H	61	70.3	3.5
4	5350.00	53.3 AV	54.0	-0.7	2.97 H	61	49.8	3.5
5	#10580.00	50.9 PK	74.0	-23.1	1.47 H	301	36.6	14.3
6	#10580.00	39.5 AV	54.0	-14.5	1.47 H	301	25.2	14.3
7	15870.00	51.4 PK	74.0	-22.6	1.44 H	132	36.4	15.0
8	15870.00	41.4 AV	54.0	-12.6	1.44 H	132	26.4	15.0

ANTENNA POLARITY & TEST DISTANCE: VERTICAL AT 3 M

NO.	FREQ. (MHz)	EMISSION LEVEL (dBuV/m)	LIMIT (dBuV/m)	MARGIN (dB)	ANTENNA HEIGHT (m)	TABLE ANGLE (Degree)	RAW VALUE (dBuV)	CORRECTION FACTOR (dB/m)
1	*5290.00	89.5 PK			2.59 V	81	86.2	3.3
2	*5290.00	78.7 AV			2.59 V	81	75.4	3.3
3	5350.00	51.7 PK	74.0	-22.3	2.59 V	81	48.2	3.5
4	5350.00	41.0 AV	54.0	-13.0	2.59 V	81	37.5	3.5
5	#10580.00	50.1 PK	74.0	-23.9	1.04 V	356	35.8	14.3
6	#10580.00	39.3 AV	54.0	-14.7	1.04 V	356	25.0	14.3
7	15870.00	51.6 PK	74.0	-22.4	1.02 V	350	36.6	15.0
8	15870.00	41.5 AV	54.0	-12.5	1.02 V	350	26.5	15.0

Remark:

1. Emission Level(dBuV/m) = Raw Value(dBuV) + Correction Factor(dB/m)
2. Correction Factor(dB/m) = Antenna Factor(dB/m) + Cable Factor(dB)
3. The other emission levels were very low against the limit.
4. Margin value = Emission Level – Limit value
5. " * ": Fundamental frequency.
6. " # ": The radiated frequency is out of the restricted band.

CHANNEL	TX Channel 106	DETECTOR FUNCTION	Peak (PK)
FREQUENCY RANGE	1GHz ~ 40GHz		Average (AV)

ANTENNA POLARITY & TEST DISTANCE: HORIZONTAL AT 3 M								
NO.	FREQ. (MHz)	EMISSION LEVEL (dBuV/m)	LIMIT (dBuV/m)	MARGIN (dB)	ANTENNA HEIGHT (m)	TABLE ANGLE (Degree)	RAW VALUE (dBuV)	CORRECTION FACTOR (dB/m)
1	#5466.00	73.9 PK	74.0	-0.1	2.93 H	74	70.2	3.7
2	#5466.00	50.9 AV	54.0	-3.1	2.93 H	74	47.2	3.7
3	*5530.00	103.5 PK			2.93 H	74	99.6	3.9
4	*5530.00	93.1 AV			2.93 H	74	89.2	3.9
5	#5725.00	53.9 PK	74.0	-20.1	2.93 H	74	49.7	4.2
6	#5725.00	42.3 AV	54.0	-11.7	2.93 H	74	38.1	4.2
7	11060.00	51.3 PK	74.0	-22.7	1.49 H	319	36.2	15.1
8	11060.00	39.9 AV	54.0	-14.1	1.49 H	319	24.8	15.1
9	#16590.00	51.0 PK	74.0	-23.0	1.39 H	138	33.3	17.7
10	#16590.00	40.9 AV	54.0	-13.1	1.39 H	138	23.2	17.7

ANTENNA POLARITY & TEST DISTANCE: VERTICAL AT 3 M								
NO.	FREQ. (MHz)	EMISSION LEVEL (dBuV/m)	LIMIT (dBuV/m)	MARGIN (dB)	ANTENNA HEIGHT (m)	TABLE ANGLE (Degree)	RAW VALUE (dBuV)	CORRECTION FACTOR (dB/m)
1	#5466.00	52.2 PK	74.0	-21.8	2.62 V	80	48.5	3.7
2	#5466.00	41.3 AV	54.0	-12.7	2.62 V	80	37.6	3.7
3	*5530.00	90.6 PK			2.62 V	80	86.7	3.9
4	*5530.00	79.9 AV			2.62 V	80	76.0	3.9
5	#5725.00	52.1 PK	74.0	-21.9	2.62 V	80	47.9	4.2
6	#5725.00	41.1 AV	54.0	-12.9	2.62 V	80	36.9	4.2
7	11060.00	50.4 PK	74.0	-23.6	1.07 V	360	35.3	15.1
8	11060.00	39.4 AV	54.0	-14.6	1.07 V	360	24.3	15.1
9	#16590.00	51.1 PK	74.0	-22.9	1.10 V	347	33.4	17.7
10	#16590.00	40.8 AV	54.0	-13.2	1.10 V	347	23.1	17.7

Remark:

1. Emission Level(dBuV/m) = Raw Value(dBuV) + Correction Factor(dB/m)
2. Correction Factor(dB/m) = Antenna Factor(dB/m) + Cable Factor(dB)
3. The other emission levels were very low against the limit.
4. Margin value = Emission Level – Limit value
5. " * ": Fundamental frequency.
6. " # ": The radiated frequency is out of the restricted band.

CHANNEL	TX Channel 122	DETECTOR FUNCTION	Peak (PK)
FREQUENCY RANGE	1GHz ~ 40GHz		Average (AV)

ANTENNA POLARITY & TEST DISTANCE: HORIZONTAL AT 3 M

NO.	FREQ. (MHz)	EMISSION LEVEL (dBuV/m)	LIMIT (dBuV/m)	MARGIN (dB)	ANTENNA HEIGHT (m)	TABLE ANGLE (Degree)	RAW VALUE (dBuV)	CORRECTION FACTOR (dB/m)
1	#5470.00	63.2 PK	74.0	-10.8	3.69 H	360	59.5	3.7
2	#5470.00	47.9 AV	54.0	-6.1	3.69 H	360	44.2	3.7
3	*5610.00	107.9 PK			3.69 H	360	104.0	3.9
4	*5610.00	98.9 AV			3.69 H	360	95.0	3.9
5	#5730.00	72.6 PK	74.0	-1.4	3.69 H	360	68.4	4.2
6	#5730.00	53.2 AV	54.0	-0.8	3.69 H	360	49.0	4.2
7	11220.00	50.7 PK	74.0	-23.3	1.53 H	304	35.5	15.2
8	11220.00	39.3 AV	54.0	-14.7	1.53 H	304	24.1	15.2
9	#16830.00	51.3 PK	74.0	-22.7	1.41 H	158	32.8	18.5
10	#16830.00	41.4 AV	54.0	-12.6	1.41 H	158	22.9	18.5

ANTENNA POLARITY & TEST DISTANCE: VERTICAL AT 3 M

NO.	FREQ. (MHz)	EMISSION LEVEL (dBuV/m)	LIMIT (dBuV/m)	MARGIN (dB)	ANTENNA HEIGHT (m)	TABLE ANGLE (Degree)	RAW VALUE (dBuV)	CORRECTION FACTOR (dB/m)
1	#5470.00	51.5 PK	74.0	-22.5	2.67 V	78	47.8	3.7
2	#5470.00	40.7 AV	54.0	-13.3	2.67 V	78	37.0	3.7
3	*5610.00	95.1 PK			2.67 V	78	91.2	3.9
4	*5610.00	85.9 AV			2.67 V	78	82.0	3.9
5	#5730.00	51.7 PK	74.0	-22.3	2.67 V	78	47.5	4.2
6	#5730.00	41.1 AV	54.0	-12.9	2.67 V	78	36.9	4.2
7	11220.00	49.7 PK	74.0	-24.3	1.10 V	360	34.5	15.2
8	11220.00	38.8 AV	54.0	-15.2	1.10 V	360	23.6	15.2
9	#16830.00	51.7 PK	74.0	-22.3	1.10 V	356	33.2	18.5
10	#16830.00	41.5 AV	54.0	-12.5	1.10 V	356	23.0	18.5

Remark:

1. Emission Level(dBuV/m) = Raw Value(dBuV) + Correction Factor(dB/m)
2. Correction Factor(dB/m) = Antenna Factor(dB/m) + Cable Factor(dB)
3. The other emission levels were very low against the limit.
4. Margin value = Emission Level – Limit value
5. " * ": Fundamental frequency.
6. " # ": The radiated frequency is out of the restricted band.

CHANNEL	TX Channel 138	DETECTOR FUNCTION	Peak (PK)
FREQUENCY RANGE	1GHz ~ 40GHz		Average (AV)

ANTENNA POLARITY & TEST DISTANCE: HORIZONTAL AT 3 M								
NO.	FREQ. (MHz)	EMISSION LEVEL (dBuV/m)	LIMIT (dBuV/m)	MARGIN (dB)	ANTENNA HEIGHT (m)	TABLE ANGLE (Degree)	RAW VALUE (dBuV)	CORRECTION FACTOR (dB/m)
1	#5470.00	59.3 PK	74.0	-14.7	3.08 H	360	55.6	3.7
2	#5470.00	47.7 AV	54.0	-6.3	3.08 H	360	44.0	3.7
3	*5690.00	110.5 PK			3.08 H	360	106.3	4.2
4	*5690.00	99.6 AV			3.08 H	360	95.4	4.2
5	#5850.00	51.2 PK	74.0	-22.8	3.08 H	360	47.0	4.2
6	#5850.00	51.2 AV	54.0	-2.8	3.08 H	360	47.0	4.2
7	11380.00	50.9 PK	74.0	-23.1	1.52 H	305	35.5	15.4
8	11380.00	39.3 AV	54.0	-14.7	1.52 H	305	23.9	15.4
9	#17070.00	51.7 PK	74.0	-22.3	1.36 H	129	31.7	20.0
10	#17070.00	41.5 AV	54.0	-12.5	1.36 H	129	21.5	20.0

ANTENNA POLARITY & TEST DISTANCE: VERTICAL AT 3 M								
NO.	FREQ. (MHz)	EMISSION LEVEL (dBuV/m)	LIMIT (dBuV/m)	MARGIN (dB)	ANTENNA HEIGHT (m)	TABLE ANGLE (Degree)	RAW VALUE (dBuV)	CORRECTION FACTOR (dB/m)
1	#5470.00	51.7 PK	74.0	-22.3	2.64 V	62	48.0	3.7
2	#5470.00	40.9 AV	54.0	-13.1	2.64 V	62	37.2	3.7
3	*5690.00	97.7 PK			2.64 V	62	93.5	4.2
4	*5690.00	87.1 AV			2.64 V	62	82.9	4.2
5	#5850.00	51.5 PK	74.0	-22.5	2.64 V	62	47.3	4.2
6	#5850.00	40.8 AV	54.0	-13.2	2.64 V	62	36.6	4.2
7	11380.00	50.0 PK	74.0	-24.0	1.11 V	360	34.6	15.4
8	11380.00	38.9 AV	54.0	-15.1	1.11 V	360	23.5	15.4
9	#17070.00	51.2 PK	74.0	-22.8	1.01 V	351	31.2	20.0
10	#17070.00	40.9 AV	54.0	-13.1	1.01 V	351	20.9	20.0

Remark:

1. Emission Level(dBuV/m) = Raw Value(dBuV) + Correction Factor(dB/m)
2. Correction Factor(dB/m) = Antenna Factor(dB/m) + Cable Factor(dB)
3. The other emission levels were very low against the limit.
4. Margin value = Emission Level – Limit value
5. " * ": Fundamental frequency.
6. " # ": The radiated frequency is out of the restricted band.

Below 1GHz Worst-Case Data:

Radio 1 - 4TX CDD Mode

802.11ac (VHT40)

CHANNEL	TX Channel 110	DETECTOR FUNCTION	Quasi-Peak (QP)
FREQUENCY RANGE	30MHz ~ 1GHz		
TEST MODE	A		

ANTENNA POLARITY & TEST DISTANCE: HORIZONTAL AT 3 M								
NO.	FREQ. (MHz)	EMISSION LEVEL (dBuV/m)	LIMIT (dBuV/m)	MARGIN (dB)	ANTENNA HEIGHT (m)	TABLE ANGLE (Degree)	RAW VALUE (dBuV)	CORRECTION FACTOR (dB/m)
1	98.16	31.1 QP	43.5	-12.4	2.00 H	222	44.3	-13.2
2	209.44	34.1 QP	43.5	-9.4	1.50 H	224	45.5	-11.4
3	269.14	30.3 QP	46.0	-15.7	1.00 H	111	38.8	-8.5
4	343.54	30.3 QP	46.0	-15.7	1.00 H	302	36.8	-6.5
5	400.06	33.2 QP	46.0	-12.8	1.00 H	205	38.2	-5.0
6	800.13	33.5 QP	46.0	-12.5	1.00 H	123	30.4	3.1
ANTENNA POLARITY & TEST DISTANCE: VERTICAL AT 3 M								
NO.	FREQ. (MHz)	EMISSION LEVEL (dBuV/m)	LIMIT (dBuV/m)	MARGIN (dB)	ANTENNA HEIGHT (m)	TABLE ANGLE (Degree)	RAW VALUE (dBuV)	CORRECTION FACTOR (dB/m)
1	37.39	35.4 QP	40.0	-4.6	1.00 V	308	44.8	-9.4
2	72.08	35.2 QP	40.0	-4.8	1.00 V	114	46.2	-11.0
3	157.03	35.1 QP	43.5	-8.4	1.00 V	108	43.4	-8.3
4	302.34	34.4 QP	46.0	-11.6	1.00 V	306	41.7	-7.3
5	400.08	32.2 QP	46.0	-13.8	1.00 V	127	37.2	-5.0
6	644.05	30.2 QP	46.0	-15.8	2.00 V	196	29.5	0.7

Remarks:

1. Emission Level(dBuV/m) = Raw Value(dBuV) + Correction Factor(dB/m)
2. Correction Factor(dB/m) = Antenna Factor(dB/m) + Cable Factor(dB)
3. The other emission levels were very low against the limit.
4. Margin value = Emission Level – Limit value

CHANNEL	TX Channel 110	DETECTOR FUNCTION	Quasi-Peak (QP)
FREQUENCY RANGE	30MHz ~ 1GHz		
TEST MODE	B		

ANTENNA POLARITY & TEST DISTANCE: HORIZONTAL AT 3 M

NO.	FREQ. (MHz)	EMISSION LEVEL (dBuV/m)	LIMIT (dBuV/m)	MARGIN (dB)	ANTENNA HEIGHT (m)	TABLE ANGLE (Degree)	RAW VALUE (dBuV)	CORRECTION FACTOR (dB/m)
1	147.97	33.7 QP	43.5	-9.8	1.00 H	104	42.1	-8.4
2	181.05	37.6 QP	43.5	-5.9	4.00 H	280	47.3	-9.7
3	274.54	34.8 QP	46.0	-11.2	1.50 H	338	43.0	-8.2
4	399.81	35.9 QP	46.0	-10.1	2.00 H	194	40.9	-5.0
5	799.54	36.0 QP	46.0	-10.0	1.00 H	264	32.9	3.1
6	900.31	34.5 QP	46.0	-11.6	1.41 H	249	30.2	4.3

ANTENNA POLARITY & TEST DISTANCE: VERTICAL AT 3 M

NO.	FREQ. (MHz)	EMISSION LEVEL (dBuV/m)	LIMIT (dBuV/m)	MARGIN (dB)	ANTENNA HEIGHT (m)	TABLE ANGLE (Degree)	RAW VALUE (dBuV)	CORRECTION FACTOR (dB/m)
1	66.41	36.1 QP	40.0	-3.9	2.00 V	332	45.9	-9.8
2	149.14	36.4 QP	43.5	-7.1	2.00 V	217	44.8	-8.4
3	181.38	35.5 QP	43.5	-8.0	1.50 V	220	45.2	-9.7
4	275.35	34.4 QP	46.0	-11.7	3.00 V	216	42.5	-8.2
5	399.68	35.6 QP	46.0	-10.4	1.00 V	294	40.7	-5.0
6	900.46	33.4 QP	46.0	-12.7	1.00 V	287	29.1	4.3

Remarks:

1. Emission Level(dBuV/m) = Raw Value(dBuV) + Correction Factor(dB/m)
2. Correction Factor(dB/m) = Antenna Factor(dB/m) + Cable Factor(dB)
3. The other emission levels were very low against the limit.
4. Margin value = Emission Level – Limit value

Radio 2 - 4TX with PIFA antenna CDD Mode

802.11ac (VHT40)

CHANNEL	TX Channel 110	DETECTOR FUNCTION	Quasi-Peak (QP)
FREQUENCY RANGE	30MHz ~ 1GHz		
TEST MODE	A		

ANTENNA POLARITY & TEST DISTANCE: HORIZONTAL AT 3 M

NO.	FREQ. (MHz)	EMISSION LEVEL (dBuV/m)	LIMIT (dBuV/m)	MARGIN (dB)	ANTENNA HEIGHT (m)	TABLE ANGLE (Degree)	RAW VALUE (dBuV)	CORRECTION FACTOR (dB/m)
1	98.13	31.2 QP	43.5	-12.3	2.00 H	247	44.4	-13.2
2	209.47	34.1 QP	43.5	-9.4	1.50 H	226	45.5	-11.4
3	269.16	30.4 QP	46.0	-15.6	1.00 H	116	38.9	-8.5
4	343.56	30.3 QP	46.0	-15.7	1.00 H	305	36.8	-6.5
5	400.23	33.3 QP	46.0	-12.7	1.00 H	207	38.3	-5.0
6	800.15	33.5 QP	46.0	-12.5	1.00 H	124	30.4	3.1

ANTENNA POLARITY & TEST DISTANCE: VERTICAL AT 3 M

NO.	FREQ. (MHz)	EMISSION LEVEL (dBuV/m)	LIMIT (dBuV/m)	MARGIN (dB)	ANTENNA HEIGHT (m)	TABLE ANGLE (Degree)	RAW VALUE (dBuV)	CORRECTION FACTOR (dB/m)
1	37.26	35.3 QP	40.0	-4.7	1.00 V	318	44.7	-9.4
2	72.16	35.3 QP	40.0	-4.7	1.00 V	124	46.3	-11.0
3	157.12	35.2 QP	43.5	-8.3	1.00 V	117	43.5	-8.3
4	302.27	34.4 QP	46.0	-11.6	1.00 V	314	41.7	-7.3
5	400.15	32.1 QP	46.0	-13.9	1.00 V	134	37.1	-5.0
6	644.15	30.1 QP	46.0	-15.9	2.00 V	214	29.4	0.7

Remarks:

1. Emission Level(dBuV/m) = Raw Value(dBuV) + Correction Factor(dB/m)
2. Correction Factor(dB/m) = Antenna Factor(dB/m) + Cable Factor(dB)
3. The other emission levels were very low against the limit.
4. Margin value = Emission Level – Limit value

CHANNEL	TX Channel 110	DETECTOR FUNCTION	Quasi-Peak (QP)
FREQUENCY RANGE	30MHz ~ 1GHz		
TEST MODE	B		

ANTENNA POLARITY & TEST DISTANCE: HORIZONTAL AT 3 M

NO.	FREQ. (MHz)	EMISSION LEVEL (dBuV/m)	LIMIT (dBuV/m)	MARGIN (dB)	ANTENNA HEIGHT (m)	TABLE ANGLE (Degree)	RAW VALUE (dBuV)	CORRECTION FACTOR (dB/m)
1	149.44	34.3 QP	43.5	-9.2	2.00 H	206	42.7	-8.4
2	181.07	37.3 QP	43.5	-6.2	2.00 H	260	47.0	-9.7
3	275.12	35.6 QP	46.0	-10.4	1.00 H	303	43.8	-8.2
4	400.24	36.5 QP	46.0	-9.5	1.00 H	198	41.5	-5.0
5	799.92	36.7 QP	46.0	-9.3	1.00 H	259	33.7	3.1
6	899.93	34.9 QP	46.0	-11.1	1.50 H	248	30.7	4.3

ANTENNA POLARITY & TEST DISTANCE: VERTICAL AT 3 M

NO.	FREQ. (MHz)	EMISSION LEVEL (dBuV/m)	LIMIT (dBuV/m)	MARGIN (dB)	ANTENNA HEIGHT (m)	TABLE ANGLE (Degree)	RAW VALUE (dBuV)	CORRECTION FACTOR (dB/m)
1	66.75	36.4 QP	40.0	-3.6	2.00 V	298	46.3	-9.9
2	149.47	36.7 QP	43.5	-6.8	2.00 V	358	45.1	-8.4
3	181.56	35.8 QP	43.5	-7.7	1.50 V	200	45.5	-9.7
4	274.97	34.2 QP	46.0	-11.8	2.00 V	216	42.4	-8.2
5	399.49	35.9 QP	46.0	-10.1	1.00 V	260	40.9	-5.0
6	900.32	33.6 QP	46.0	-12.4	1.00 V	259	29.4	4.3

Remarks:

1. Emission Level(dBuV/m) = Raw Value(dBuV) + Correction Factor(dB/m)
2. Correction Factor(dB/m) = Antenna Factor(dB/m) + Cable Factor(dB)
3. The other emission levels were very low against the limit.
4. Margin value = Emission Level – Limit value

Radio 2 - 4TX with Dipole antenna CDD Mode

802.11ac (VHT40)

CHANNEL	TX Channel 110	DETECTOR FUNCTION	Quasi-Peak (QP)
FREQUENCY RANGE	30MHz ~ 1GHz		
TEST MODE	A		

ANTENNA POLARITY & TEST DISTANCE: HORIZONTAL AT 3 M

NO.	FREQ. (MHz)	EMISSION LEVEL (dBuV/m)	LIMIT (dBuV/m)	MARGIN (dB)	ANTENNA HEIGHT (m)	TABLE ANGLE (Degree)	RAW VALUE (dBuV)	CORRECTION FACTOR (dB/m)
1	98.23	31.1 QP	43.5	-12.4	2.00 H	234	44.3	-13.2
2	209.36	34.2 QP	43.5	-9.3	1.50 H	215	45.6	-11.4
3	269.25	30.3 QP	46.0	-15.7	1.00 H	104	38.8	-8.5
4	343.45	30.2 QP	46.0	-15.8	1.00 H	316	36.7	-6.5
5	400.32	33.3 QP	46.0	-12.7	1.00 H	215	38.3	-5.0
6	800.26	33.4 QP	46.0	-12.6	1.00 H	114	30.3	3.1

ANTENNA POLARITY & TEST DISTANCE: VERTICAL AT 3 M

NO.	FREQ. (MHz)	EMISSION LEVEL (dBuV/m)	LIMIT (dBuV/m)	MARGIN (dB)	ANTENNA HEIGHT (m)	TABLE ANGLE (Degree)	RAW VALUE (dBuV)	CORRECTION FACTOR (dB/m)
1	37.45	35.4 QP	40.0	-4.6	1.00 V	315	44.8	-9.4
2	72.17	35.1 QP	40.0	-4.9	1.00 V	126	46.1	-11.0
3	157.04	35.1 QP	43.5	-8.4	1.00 V	127	43.4	-8.3
4	302.35	34.5 QP	46.0	-11.5	1.00 V	303	41.8	-7.3
5	400.07	32.2 QP	46.0	-13.8	1.00 V	128	37.2	-5.0
6	644.22	30.2 QP	46.0	-15.8	2.00 V	217	29.5	0.7

Remarks:

1. Emission Level(dBuV/m) = Raw Value(dBuV) + Correction Factor(dB/m)
2. Correction Factor(dB/m) = Antenna Factor(dB/m) + Cable Factor(dB)
3. The other emission levels were very low against the limit.
4. Margin value = Emission Level – Limit value

CHANNEL	TX Channel 110	DETECTOR FUNCTION	Quasi-Peak (QP)
FREQUENCY RANGE	30MHz ~ 1GHz		
TEST MODE	B		

ANTENNA POLARITY & TEST DISTANCE: HORIZONTAL AT 3 M

NO.	FREQ. (MHz)	EMISSION LEVEL (dBuV/m)	LIMIT (dBuV/m)	MARGIN (dB)	ANTENNA HEIGHT (m)	TABLE ANGLE (Degree)	RAW VALUE (dBuV)	CORRECTION FACTOR (dB/m)
1	147.87	34.5 QP	43.5	-9.0	2.00 H	215	42.9	-8.4
2	181.08	37.8 QP	43.5	-5.7	1.50 H	326	47.4	-9.7
3	275.18	35.2 QP	46.0	-10.8	2.00 H	291	43.4	-8.2
4	399.99	36.1 QP	46.0	-9.9	1.00 H	181	41.1	-5.0
5	800.07	36.7 QP	46.0	-9.3	1.00 H	261	33.7	3.1
6	900.17	34.9 QP	46.0	-11.1	1.50 H	217	30.6	4.3

ANTENNA POLARITY & TEST DISTANCE: VERTICAL AT 3 M

NO.	FREQ. (MHz)	EMISSION LEVEL (dBuV/m)	LIMIT (dBuV/m)	MARGIN (dB)	ANTENNA HEIGHT (m)	TABLE ANGLE (Degree)	RAW VALUE (dBuV)	CORRECTION FACTOR (dB/m)
1	66.30	35.8 QP	40.0	-4.2	2.00 V	355	45.6	-9.8
2	149.55	36.6 QP	43.5	-6.9	2.00 V	268	45.0	-8.4
3	181.64	35.7 QP	43.5	-7.8	1.50 V	290	45.5	-9.7
4	275.60	34.5 QP	46.0	-11.5	3.00 V	166	42.7	-8.2
5	399.50	35.3 QP	46.0	-10.7	1.50 V	267	40.4	-5.0
6	900.78	33.7 QP	46.0	-12.3	1.00 V	303	29.4	4.3

Remarks:

1. Emission Level(dBuV/m) = Raw Value(dBuV) + Correction Factor(dB/m)
2. Correction Factor(dB/m) = Antenna Factor(dB/m) + Cable Factor(dB)
3. The other emission levels were very low against the limit.
4. Margin value = Emission Level – Limit value

4.2 Conducted Emission Measurement

4.2.1 Limits of Conducted Emission Measurement

Frequency (MHz)	Conducted Limit (dBuV)	
	Quasi-peak	Average
0.15 - 0.5	66 - 56	56 - 46
0.50 - 5.0	56	46
5.0 - 30.0	60	50

- Note:** 1. The lower limit shall apply at the transition frequencies.
 2. The limit decreases in line with the logarithm of the frequency in the range of 0.15 to 0.50MHz.

4.2.2 Test Instruments

Description & Manufacturer	Model No.	Serial No.	Cal. Date	Cal. Due
Test Receiver R&S	ESCS 30	847124/029	Oct. 23, 2015	Oct. 22, 2016
Line-Impedance Stabilization Network (for EUT) R&S	ESH3-Z5	848773/004	Oct. 28, 2015	Oct. 27, 2016
RF Cable	5D-FB	COACAB-002	Mar. 04, 2016	Mar. 03, 2017
10 dB PAD Mini-Circuits	HAT-10+	CONATT-004	Jun. 20, 2015	Jun. 19, 2016
Software BVADT	BVADT_Cond_ V7.3.7.3	NA	NA	NA

Note:

- The test was performed in Shielded Room No. 1.
- The calibration interval of the above test instruments is 12 months and the calibrations are traceable to NML/ROC and NIST/USA.
- Tested Date: Jun. 17, 2016

4.2.3 Test Procedures

- The EUT was placed 0.4 meters from the conducting wall of the shielded room with EUT being connected to the power mains through a line impedance stabilization network (LISN). Other support units were connected to the power mains through another LISN. The two LISNs provide 50 ohm/ 50uH of coupling impedance for the measuring instrument.
- Both lines of the power mains connected to the EUT were checked for maximum conducted interference.
- The frequency range from 150kHz to 30MHz was searched. Emission levels under (Limit - 20dB) was not recorded.

Note: The resolution bandwidth and video bandwidth of test receiver is 9kHz for quasi-peak detection (QP) and average detection (AV) at frequency 0.15MHz-30MHz.

4.2.4 Deviation from Test Standard

No deviation.

4.2.5 Test Setup

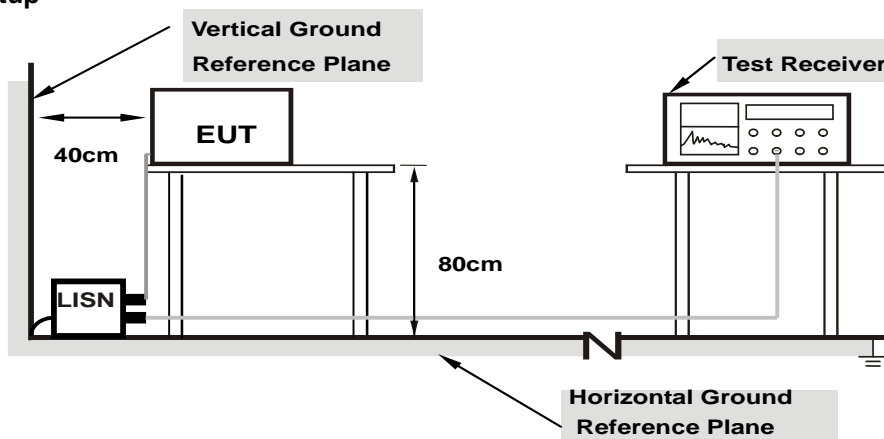

Note: 1.Support units were connected to second LISN.

For the actual test configuration, please refer to the attached file (Test Setup Photo).

4.2.6 EUT Operating Conditions

Same as 4.1.6.

4.2.7 Test Results

Radio 1 - 4TX CDD Mode

Phase	Line (L)	Detector Function	Quasi-Peak (QP) / Average (AV)
Test Mode	A		

No	Freq. [MHz]	Corr. Factor (dB)	Reading Value		Emission Level		Limit		Margin	
			[dB (uV)]		[dB (uV)]		[dB (uV)]		(dB)	
			Q.P.	AV.	Q.P.	AV.	Q.P.	AV.	Q.P.	AV.
1	0.18516	10.22	37.01	27.50	47.23	37.72	64.25	54.25	-17.02	-16.53
2	0.22422	10.22	31.17	20.76	41.39	30.98	62.66	52.66	-21.27	-21.68
3	0.37838	10.22	27.28	14.11	37.50	24.33	58.31	48.31	-20.81	-23.98
4	0.84531	10.25	20.15	10.40	30.40	20.65	56.00	46.00	-25.60	-25.35
5	2.05469	10.31	14.18	4.76	24.49	15.07	56.00	46.00	-31.51	-30.93
6	19.66016	11.33	26.10	23.44	37.43	34.77	60.00	50.00	-22.57	-15.23

Remarks:

1. Q.P. and AV. are abbreviations of quasi-peak and average individually.
2. The emission levels of other frequencies were very low against the limit.
3. Margin value = Emission level - Limit value
4. Correction factor = Insertion loss + Cable loss
5. Emission Level = Correction Factor + Reading Value.

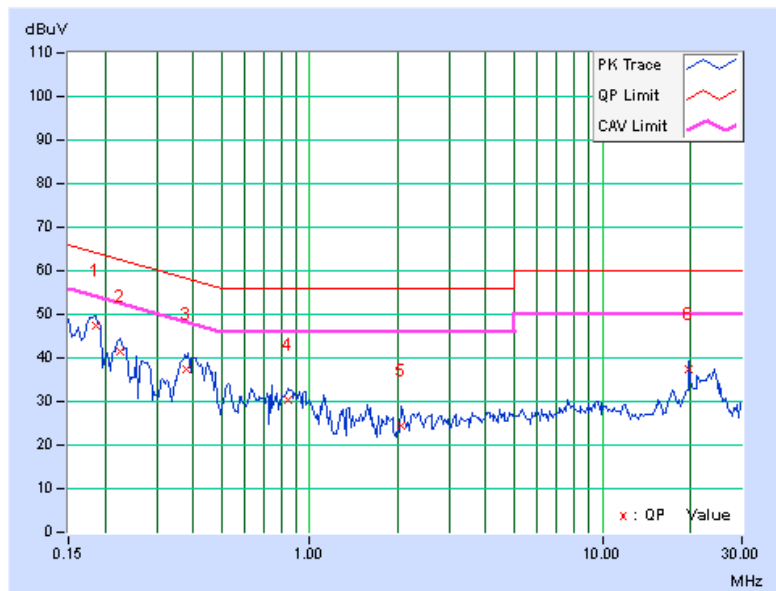

Phase	Neutral (N)	Detector Function	Quasi-Peak (QP) / Average (AV)
Test Mode	A		

No	Freq. [MHz]	Corr. Factor (dB)	Reading Value [dB (uV)]		Emission Level [dB (uV)]		Limit [dB (uV)]		Margin (dB)	
			Q.P.	AV.	Q.P.	AV.	Q.P.	AV.	Q.P.	AV.
			1	0.18125	10.20	38.40	29.26	48.60	39.46	64.43
2	0.22422	10.21	31.92	21.78	42.13	31.99	62.66	52.66	-20.53	-20.67
3	0.38047	10.20	28.68	13.12	38.88	23.32	58.27	48.27	-19.39	-24.95
4	0.89219	10.23	19.10	10.16	29.33	20.39	56.00	46.00	-26.67	-25.61
5	1.55469	10.27	18.01	7.79	28.28	18.06	56.00	46.00	-27.72	-27.94
6	24.55469	11.13	20.62	14.95	31.75	26.08	60.00	50.00	-28.25	-23.92

Remarks:

1. Q.P. and AV. are abbreviations of quasi-peak and average individually.
2. The emission levels of other frequencies were very low against the limit.
3. Margin value = Emission level - Limit value
4. Correction factor = Insertion loss + Cable loss
5. Emission Level = Correction Factor + Reading Value.

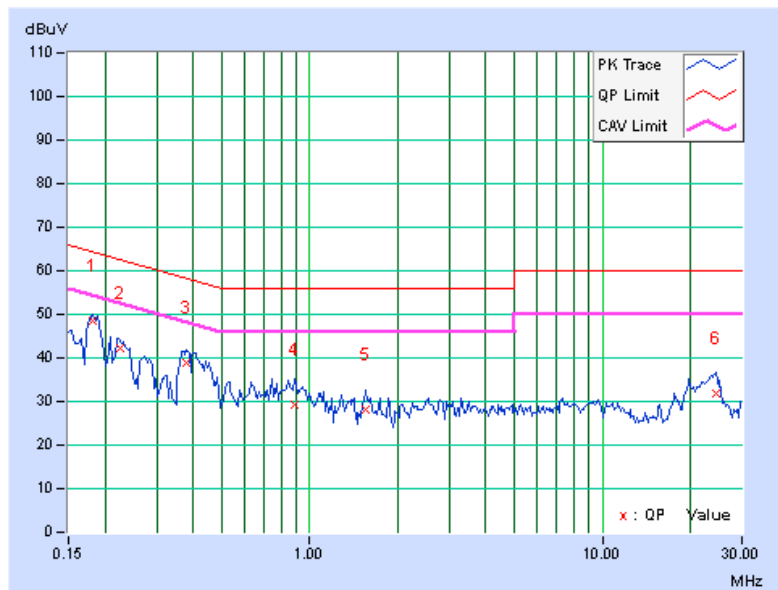

Phase	Line (L)	Detector Function	Quasi-Peak (QP) / Average (AV)
Test Mode	B		

No	Freq. [MHz]	Corr. Factor (dB)	Reading Value [dB (uV)]		Emission Level [dB (uV)]		Limit [dB (uV)]		Margin (dB)	
			Q.P.	AV.	Q.P.	AV.	Q.P.	AV.	Q.P.	AV.
			1	0.16953	10.21	36.01	23.36	46.22	33.57	64.98
2	0.23203	10.22	26.99	15.13	37.21	25.35	62.38	52.38	-25.17	-27.03
3	0.28337	10.22	25.58	14.39	35.80	24.61	60.72	50.72	-24.92	-26.11
4	0.45859	10.22	23.55	18.09	33.77	28.31	56.72	46.72	-22.94	-18.40
5	3.76563	10.29	12.86	5.81	23.15	16.10	56.00	46.00	-32.85	-29.90
6	19.22266	11.31	15.81	8.35	27.12	19.66	60.00	50.00	-32.88	-30.34

Remarks:

1. Q.P. and AV. are abbreviations of quasi-peak and average individually.
2. The emission levels of other frequencies were very low against the limit.
3. Margin value = Emission level - Limit value
4. Correction factor = Insertion loss + Cable loss
5. Emission Level = Correction Factor + Reading Value.

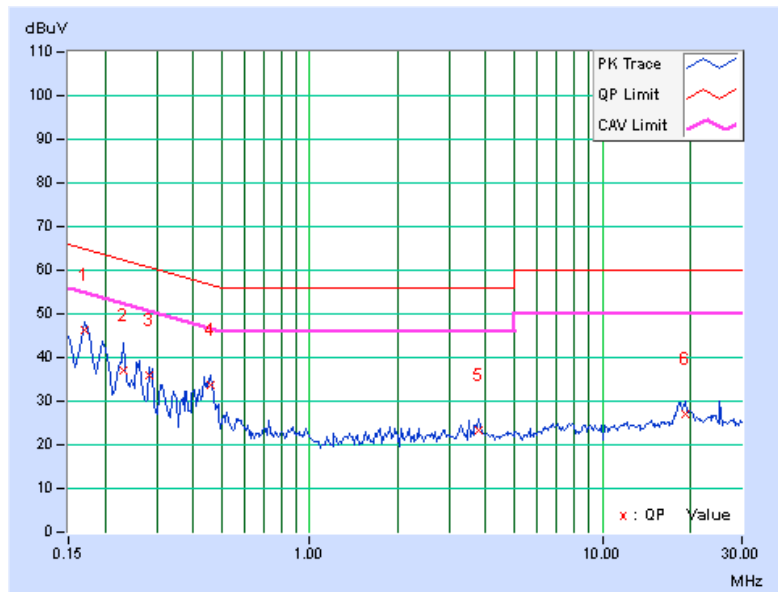

Phase	Neutral (N)	Detector Function	Quasi-Peak (QP) / Average (AV)
Test Mode	B		

No	Freq. [MHz]	Corr. Factor (dB)	Reading Value [dB (uV)]		Emission Level [dB (uV)]		Limit [dB (uV)]		Margin (dB)	
			Q.P.	AV.	Q.P.	AV.	Q.P.	AV.	Q.P.	AV.
			1	0.15000	10.19	34.35	17.07	44.54	27.26	66.00
2	0.16562	10.20	33.87	18.34	44.07	28.54	65.18	55.18	-21.11	-26.64
3	0.25547	10.21	25.68	14.27	35.89	24.48	61.58	51.58	-25.69	-27.10
4	0.45859	10.20	21.62	13.63	31.82	23.83	56.72	46.72	-24.89	-22.88
5	1.53906	10.27	12.64	5.12	22.91	15.39	56.00	46.00	-33.09	-30.61
6	25.23047	11.13	14.41	14.20	25.54	25.33	60.00	50.00	-34.46	-24.67

Remarks:

1. Q.P. and AV. are abbreviations of quasi-peak and average individually.
2. The emission levels of other frequencies were very low against the limit.
3. Margin value = Emission level - Limit value
4. Correction factor = Insertion loss + Cable loss
5. Emission Level = Correction Factor + Reading Value.

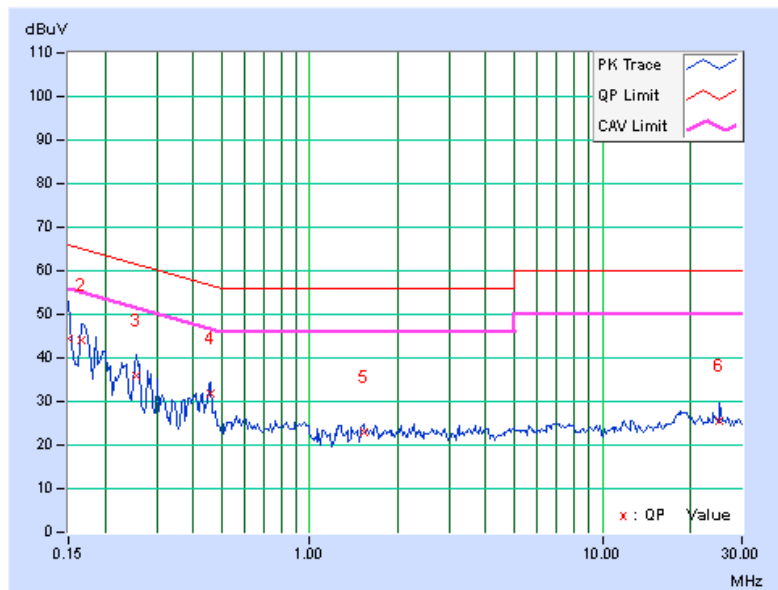

Radio 2 - 4TX with Dipole antenna CDD Mode

Phase	Line (L)	Detector Function	Quasi-Peak (QP) / Average (AV)
Test Mode	A		

No	Freq. [MHz]	Corr. Factor (dB)	Reading Value [dB (uV)]		Emission Level [dB (uV)]		Limit [dB (uV)]		Margin (dB)	
			Q.P.	AV.	Q.P.	AV.	Q.P.	AV.	Q.P.	AV.
			1	0.17734	10.22	38.78	26.58	49.00	36.80	64.61
2	0.22031	10.22	31.49	16.84	41.71	27.06	62.81	52.81	-21.10	-25.75
3	0.38047	10.22	25.42	9.59	35.64	19.81	58.27	48.27	-22.63	-28.46
4	0.84922	10.25	19.65	10.82	29.90	21.07	56.00	46.00	-26.10	-24.93
5	2.50000	10.30	13.79	5.86	24.09	16.16	56.00	46.00	-31.91	-29.84
6	24.00000	11.43	25.03	21.69	36.46	33.12	60.00	50.00	-23.54	-16.88

Remarks:

1. Q.P. and AV. are abbreviations of quasi-peak and average individually.
2. The emission levels of other frequencies were very low against the limit.
3. Margin value = Emission level - Limit value
4. Correction factor = Insertion loss + Cable loss
5. Emission Level = Correction Factor + Reading Value.

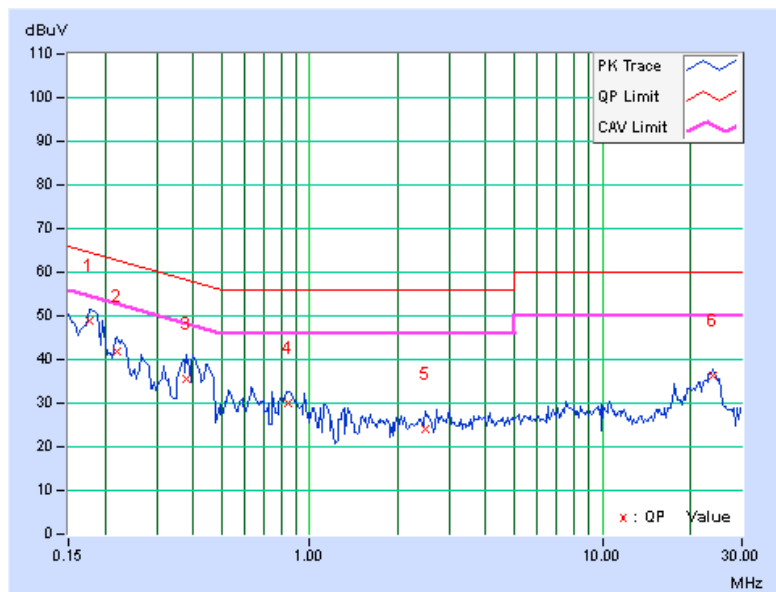

Phase	Neutral (N)	Detector Function	Quasi-Peak (QP) / Average (AV)
Test Mode	A		

No	Freq. [MHz]	Corr. Factor (dB)	Reading Value [dB (uV)]		Emission Level [dB (uV)]		Limit [dB (uV)]		Margin (dB)	
			Q.P.	AV.	Q.P.	AV.	Q.P.	AV.	Q.P.	AV.
			1	0.15391	10.19	37.77	11.99	47.96	22.18	65.79
2	0.18125	10.20	38.74	30.20	48.94	40.40	64.43	54.43	-15.49	-14.03
3	0.22331	10.21	32.34	21.22	42.55	31.43	62.69	52.69	-20.15	-21.27
4	0.40391	10.20	29.36	23.11	39.56	33.31	57.77	47.77	-18.21	-14.46
5	0.84531	10.23	21.07	11.74	31.30	21.97	56.00	46.00	-24.70	-24.03
6	23.96094	11.13	20.19	14.32	31.32	25.45	60.00	50.00	-28.68	-24.55

Remarks:

1. Q.P. and AV. are abbreviations of quasi-peak and average individually.
2. The emission levels of other frequencies were very low against the limit.
3. Margin value = Emission level - Limit value
4. Correction factor = Insertion loss + Cable loss
5. Emission Level = Correction Factor + Reading Value.

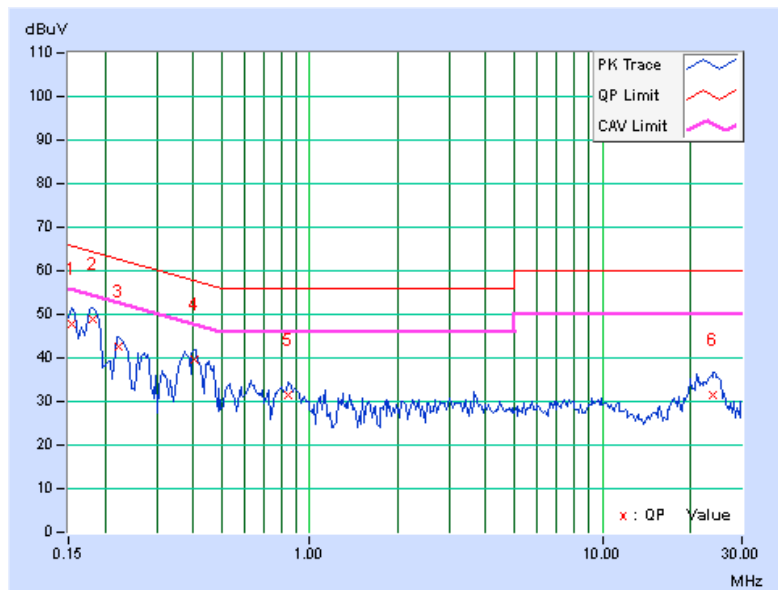

Phase	Line (L)	Detector Function	Quasi-Peak (QP) / Average (AV)
Test Mode	B		

No	Freq. [MHz]	Corr. Factor (dB)	Reading Value [dB (uV)]		Emission Level [dB (uV)]		Limit [dB (uV)]		Margin (dB)	
			Q.P.	AV.	Q.P.	AV.	Q.P.	AV.	Q.P.	AV.
			1	0.16953	10.21	36.13	23.90	46.34	34.11	64.98
2	0.23203	10.22	26.83	14.08	37.05	24.30	62.38	52.38	-25.33	-28.08
3	0.28453	10.22	25.36	15.87	35.58	26.09	60.68	50.68	-25.10	-24.59
4	0.45469	10.22	23.64	18.38	33.86	28.60	56.79	46.79	-22.93	-18.19
5	3.66797	10.29	12.35	5.62	22.64	15.91	56.00	46.00	-33.36	-30.09
6	18.51172	11.27	15.85	8.00	27.12	19.27	60.00	50.00	-32.88	-30.73

Remarks:

1. Q.P. and AV. are abbreviations of quasi-peak and average individually.
2. The emission levels of other frequencies were very low against the limit.
3. Margin value = Emission level - Limit value
4. Correction factor = Insertion loss + Cable loss
5. Emission Level = Correction Factor + Reading Value.

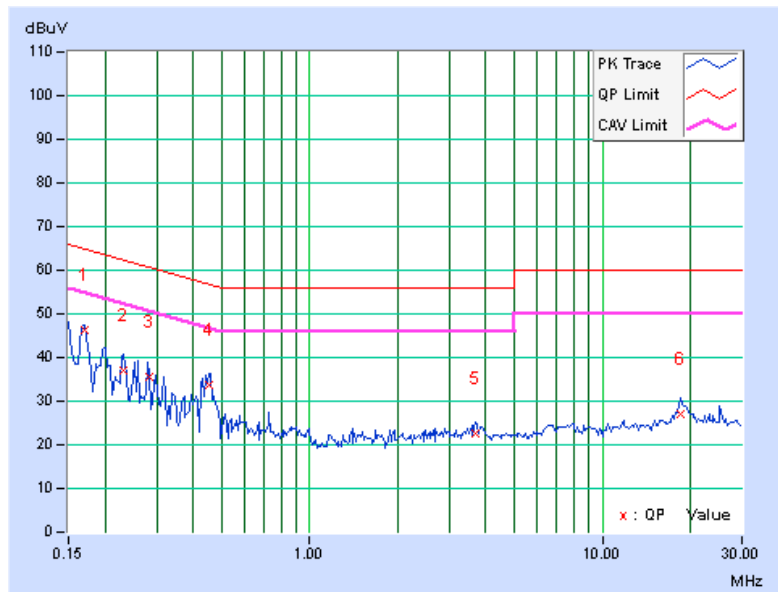

Phase	Neutral (N)	Detector Function	Quasi-Peak (QP) / Average (AV)
Test Mode	B		

No	Freq. [MHz]	Corr. Factor (dB)	Reading Value [dB (uV)]		Emission Level [dB (uV)]		Limit [dB (uV)]		Margin (dB)	
			Q.P.	AV.	Q.P.	AV.	Q.P.	AV.	Q.P.	AV.
			1	0.16953	10.20	35.71	23.52	45.91	33.72	64.98
2	0.22919	10.21	26.43	15.40	36.64	25.61	62.48	52.48	-25.84	-26.87
3	0.28281	10.21	24.43	12.51	34.64	22.72	60.73	50.73	-26.10	-28.02
4	0.45078	10.20	21.09	12.86	31.29	23.06	56.86	46.86	-25.57	-23.80
5	2.97656	10.27	12.38	5.80	22.65	16.07	56.00	46.00	-33.35	-29.93
6	25.23047	11.13	14.79	14.08	25.92	25.21	60.00	50.00	-34.08	-24.79

Remarks:

1. Q.P. and AV. are abbreviations of quasi-peak and average individually.
2. The emission levels of other frequencies were very low against the limit.
3. Margin value = Emission level - Limit value
4. Correction factor = Insertion loss + Cable loss
5. Emission Level = Correction Factor + Reading Value.

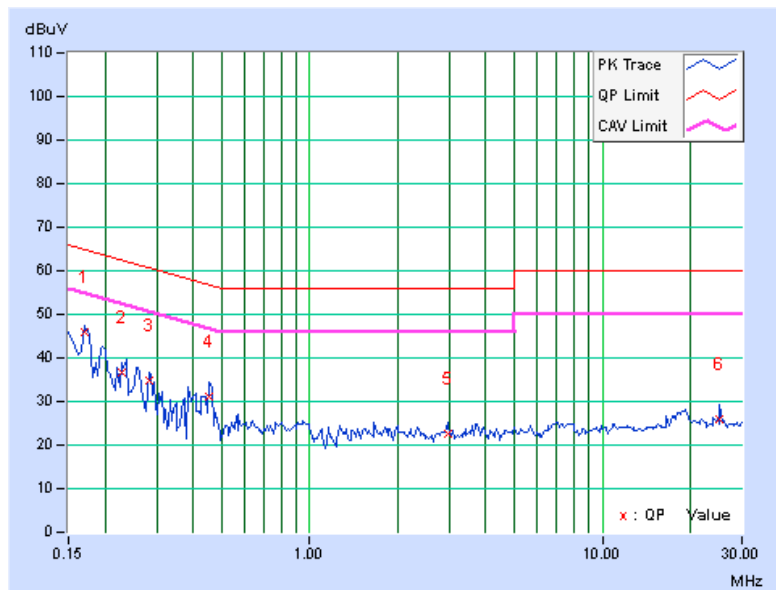

4.3 Transmit Power Measurement

4.3.1 Limits of Transmit Power Measurement

Operation Band	EUT Category		LIMIT
U-NII-1	---	Outdoor Access Point	1 Watt (30 dBm) (Max. e.i.r.p \leq 125mW(21 dBm) at any elevation angle above 30 degrees as measured from the horizon)
	---	Fixed point-to-point Access Point	1 Watt (30 dBm)
	---	Indoor Access Point	1 Watt (30 dBm)
	---	Mobile and Portable client device	250mW (24 dBm)
U-NII-2A	√		250mW (24 dBm) or 11 dBm+10 log B*
U-NII-2C	√		250mW (24 dBm) or 11 dBm+10 log B*
U-NII-3	√		1 Watt (30 dBm)

*B is the 26 dB emission bandwidth in megahertz

Per KDB 662911 Method of conducted output power measurement on IEEE 802.11 devices,

Array Gain = 0 dB (i.e., no array gain) for $N_{ANT} \leq 4$;

Array Gain = 0 dB (i.e., no array gain) for channel widths ≥ 40 MHz for any N_{ANT} ;

Array Gain = $5 \log(N_{ANT}/N_{SS})$ dB or 3 dB, whichever is less for 20-MHz channel widths with $N_{ANT} \geq 5$.

For power measurements on all other devices: Array Gain = $10 \log(N_{ANT}/N_{SS})$ dB.

4.3.2 Test Setup

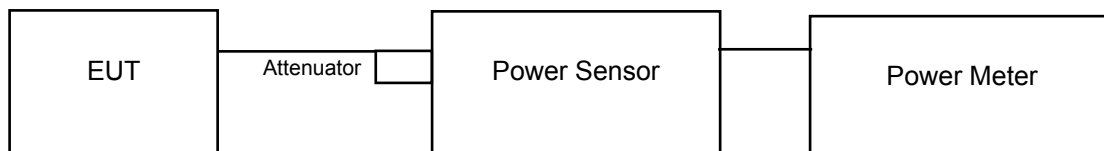

4.3.3 Test Instruments

Refer to section 4.1.2 to get information of above instrument.

4.3.4 Test Procedure

Method PM is used to perform output power measurement, trigger and gating function of wide band power meter is enabled to measure max output power of TX on burst. Duty factor is not added to measured value.

4.3.5 Deviation from Test Standard

No deviation.

4.3.6 EUT Operating Conditions

The software provided by client to enable the EUT under transmission condition continuously at lowest, middle and highest channel frequencies individually.

4.3.7 Test Result

Radio 1 - 4TX CDD Mode

802.11a

Power Output:

Chan.	Freq. (MHz)	Maximum Conducted Power (dBm)				Total Power (mW)	Total Power (dBm)	Power Limit (dBm)	Pass / Fail
		Chain 0	Chain 1	Chain 2	Chain 3				
52	5260	12.90	11.79	12.02	12.00	66.370	18.22	24.00	Pass
60	5300	12.86	11.81	12.05	12.16	66.967	18.26	24.00	Pass
64	5320	12.96	11.94	12.00	12.02	67.172	18.27	24.00	Pass
100	5500	12.55	11.91	12.40	12.62	69.172	18.40	24.00	Pass
116	5580	12.60	11.90	12.34	12.47	68.485	18.36	24.00	Pass
140	5700	12.60	12.24	12.44	12.23	69.196	18.40	24.00	Pass
144	5720 For U-NII-2C	9.59	8.99	9.21	9.24	33.756	15.28	22.98	Pass
144	5720 For U-NII-3	3.31	2.71	3.37	3.08	8.214	9.15	30.00	Pass

26dB Bandwidth:

Chan.	Freq. (MHz)	26dBc Bandwidth (MHz)				Pass / Fail
		Chain 0	Chain 1	Chain 2	Chain 3	
52	5260	21.88	21.74	21.64	21.40	Pass
60	5300	21.87	21.65	21.60	21.61	Pass
64	5320	21.89	21.73	21.59	21.48	Pass
100	5500	21.77	21.64	21.52	21.61	Pass
116	5580	21.87	21.71	21.62	21.64	Pass
140	5700	21.69	21.56	21.59	21.54	Pass
144	5720 For U-NII-2C	16.01	15.97	15.96	15.81	Pass
144	5720 For U-NII-3	5.94	5.80	5.91	5.80	Pass

Note: For FCC output poer limitation is determined based on 26dB bandwidth.

Power Limit = 11 dBm+10 log B <U-NII-2A, U-NII-2C>

Chan.	Freq. (MHz)	Min. B (MHz)	Determined Conducted Limit (dBm)
52	5260	21.40	24.30 > 24
60	5300	21.60	24.34 > 24
64	5320	21.48	24.32 > 24
100	5500	21.52	24.32 > 24
116	5580	21.62	24.34 > 24
140	5700	21.54	24.33 > 24
144	5720 For U-NII-2C	15.81	22.98 < 24

802.11ac (VHT20)

Power Output:

Chan.	Freq. (MHz)	Maximum Conducted Power (dBm)				Total Power (mW)	Total Power (dBm)	Power Limit (dBm)	Pass / Fail
		Chain 0	Chain 1	Chain 2	Chain 3				
52	5260	12.90	11.42	11.91	11.96	64.594	18.10	24.00	Pass
60	5300	12.86	11.52	11.98	11.95	64.955	18.13	24.00	Pass
64	5320	12.90	11.44	12.06	11.89	64.952	18.13	24.00	Pass
100	5500	12.36	11.90	12.15	12.32	66.174	18.21	24.00	Pass
116	5580	12.47	11.91	12.10	12.22	66.074	18.20	24.00	Pass
140	5700	12.52	12.27	12.30	12.19	68.271	18.34	24.00	Pass
144	5720 For U-NII-2C	9.74	8.83	9.30	9.20	33.886	15.30	23.01	Pass
144	5720 For U-NII-3	4.14	3.18	3.22	3.35	8.936	9.51	30.00	Pass

26dB Bandwidth:

Chan.	Freq. (MHz)	26dBc Bandwidth (MHz)				Pass / Fail
		Chain 0	Chain 1	Chain 2	Chain 3	
52	5260	22.09	21.48	22.10	21.89	Pass
60	5300	22.16	21.73	21.89	21.65	Pass
64	5320	22.01	21.79	21.90	22.00	Pass
100	5500	21.97	21.62	21.85	21.80	Pass
116	5580	21.88	21.62	21.82	21.80	Pass
140	5700	21.94	21.60	21.66	21.74	Pass
144	5720 For U-NII-2C	16.17	15.89	15.97	15.97	Pass
144	5720 For U-NII-3	6.19	5.97	5.77	5.99	Pass

Note: For FCC output power limitation is determined based on 26dB bandwidth.

Power Limit = 11 dBm+10 log B <U-NII-2A, U-NII-2C>

Chan.	Freq. (MHz)	Min. B (MHz)	Determined Conducted Limit (dBm)
52	5260	21.48	24.32 > 24
60	5300	21.65	24.35 > 24
64	5320	21.79	24.38 > 24
100	5500	21.62	24.34 > 24
116	5580	21.62	24.34 > 24
140	5700	21.60	24.34 > 24
144	5720 For U-NII-2C	15.89	23.01 < 24

802.11ac (VHT40)

Power Output:

Chan.	Freq. (MHz)	Maximum Conducted Power (dBm)				Total Power (mW)	Total Power (dBm)	Power Limit (dBm)	Pass / Fail
		Chain 0	Chain 1	Chain 2	Chain 3				
54	5270	15.41	15.26	15.01	14.52	128.338	21.08	24.00	Pass
62	5310	12.10	12.15	11.66	11.15	60.311	17.80	24.00	Pass
102	5510	13.23	12.83	13.14	12.86	80.151	19.04	24.00	Pass
110	5550	15.61	14.87	15.30	15.55	136.858	21.36	24.00	Pass
134	5670	15.72	15.16	14.90	15.53	136.765	21.36	24.00	Pass
142	5710 For U-NII-2C	12.73	12.32	12.86	13.35	76.758	18.85	24.00	Pass
142	5710 For U-NII-3	2.32	1.83	2.15	2.73	6.746	8.29	30.00	Pass

26dB Bandwidth:

Chan.	Freq. (MHz)	26dBc Bandwidth (MHz)				Pass / Fail
		Chain 0	Chain 1	Chain 2	Chain 3	
54	5270	68.22	61.75	53.07	49.00	Pass
62	5310	41.69	45.18	41.58	41.24	Pass
102	5510	47.53	41.46	41.30	41.35	Pass
110	5550	67.23	52.72	64.11	49.80	Pass
134	5670	64.90	57.93	55.93	50.62	Pass
142	5710 For U-NII-2C	50.22	45.52	47.60	47.09	Pass
142	5710 For U-NII-3	20.82	20.62	18.46	19.10	Pass

Note: For FCC output power limitation is determined based on 26dB bandwidth.

Power Limit = 11 dBm+10 log B <U-NII-2A, U-NII-2C>			
Chan.	Freq. (MHz)	Min. B (MHz)	Determined Conducted Limit (dBm)
54	5270	49.00	27.90 > 24
62	5310	41.24	27.15 > 24
102	5510	41.30	27.15 > 24
110	5550	49.80	27.97 > 24
134	5670	50.62	28.04 > 24
142	5710 For U-NII-2C	45.52	27.58 > 24

802.11ac (VHT80)

Power Output:

Chan.	Freq. (MHz)	Maximum Conducted Power (dBm)				Total Power (mW)	Total Power (dBm)	Power Limit (dBm)	Pass / Fail
		Chain 0	Chain 1	Chain 2	Chain 3				
58	5290	10.21	9.32	9.54	9.99	38.018	15.80	24.00	Pass
106	5530	10.89	10.25	10.72	10.36	45.534	16.58	24.00	Pass
122	5610	17.56	17.05	17.01	17.12	209.472	23.21	24.00	Pass
138	5690 For U-NII-2C	14.95	14.28	13.85	14.31	113.810	20.56	24.00	Pass
138	5690 For U-NII-3	1.37	0.51	-0.32	0.40	4.7077	6.73	30.00	Pass

26dB Bandwidth:

Chan.	Freq. (MHz)	26dBc Bandwidth (MHz)				Pass / Fail
		Chain 0	Chain 1	Chain 2	Chain 3	
58	5290	82.89	82.39	82.16	82.13	Pass
106	5530	83.18	82.80	82.30	82.27	Pass
122	5610	140.44	133.17	126.56	119.70	Pass
138	5690 For U-NII-2C	106.31	101.38	103.22	104.72	Pass
138	5690 For U-NII-3	42.36	31.28	29.98	29.08	Pass

Note: For FCC output poer limitation is determined based on 26dB bandwidth.

Power Limit = 11 dBm+10 log B <U-NII-2A, U-NII-2C>			
Chan.	Freq. (MHz)	Min. B (MHz)	Determined Conducted Limit (dBm)
58	5290	82.13	30.14 > 24
106	5530	82.27	30.15 > 24
122	5610	119.70	31.78 > 24
138	5690 For U-NII-2C	101.38	31.05 > 24

Spectrum Plot of Worst Value

802.11a

802.11ac (VHT20)

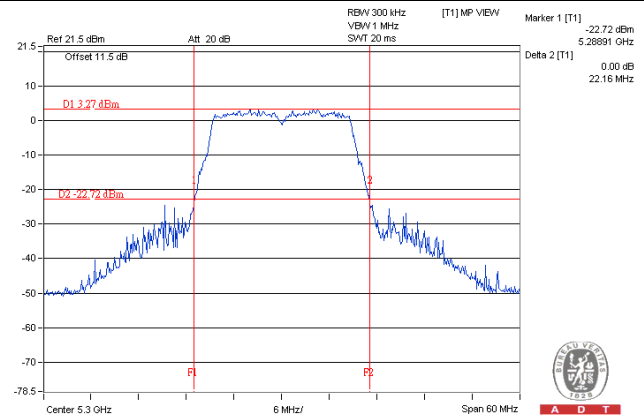
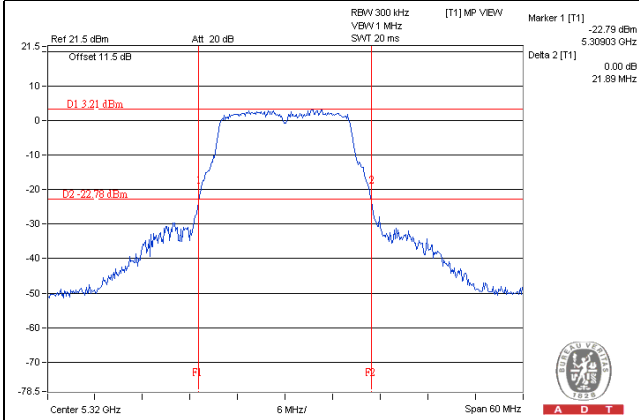

802.11ac (VHT40)

802.11ac (VHT80)

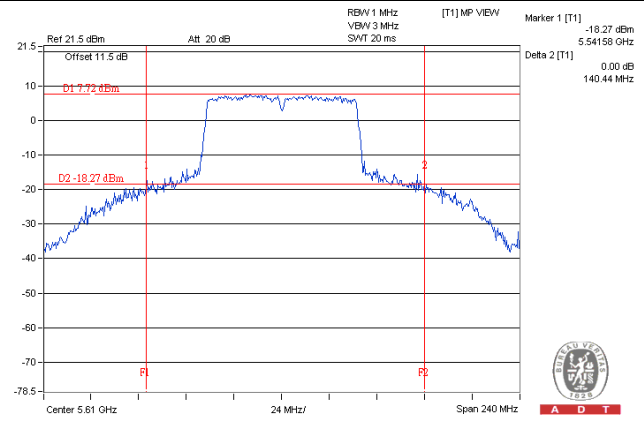
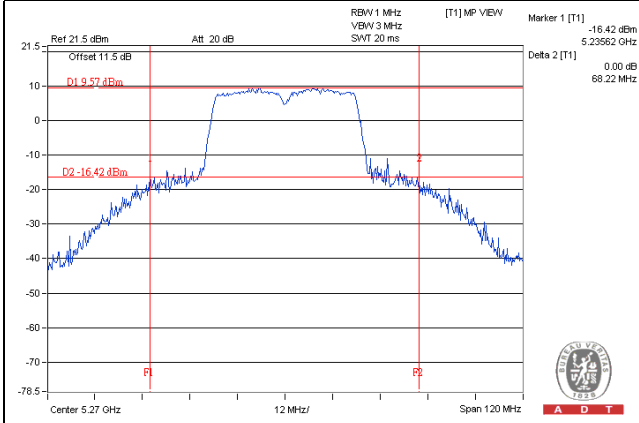

Radio 1 - 4TX TxBF Mode

802.11ac (VHT20)

Power Output:

Chan.	Freq. (MHz)	Maximum Conducted Power (dBm)				Total Power (mW)	Total Power (dBm)	Power Limit (dBm)	Pass / Fail
		Chain 0	Chain 1	Chain 2	Chain 3				
52	5260	12.90	11.42	11.91	11.96	64.594	18.10	18.31	Pass
60	5300	12.86	11.52	11.98	11.95	64.955	18.13	18.31	Pass
64	5320	12.90	11.44	12.06	11.89	64.952	18.13	18.31	Pass
100	5500	12.36	11.90	12.15	12.32	66.174	18.21	18.45	Pass
116	5580	12.47	11.91	12.10	12.22	66.074	18.20	18.45	Pass
140	5700	12.52	12.27	12.30	12.19	68.271	18.34	18.45	Pass
144	5720 For U-NII-2C	8.61	8.29	8.44	8.30	27.749	14.43	17.46	Pass
144	5720 For U-NII-3	2.89	2.54	2.15	2.46	7.143	8.54	24.19	Pass

Note:

For U-NII-2A Band: Directional gain = $10 \log[(10^{G1/20} + 10^{G2/20} + \dots + 10^{GN/20})^2/4]$ = 11.69dBi > 6dBi , so the power limit shall be reduced to "Determined Conducted Limit-(11.69-6)".

For U-NII-2C Band: Directional gain = $10 \log[(10^{G1/20} + 10^{G2/20} + \dots + 10^{GN/20})^2/4]$ = 11.55dBi > 6dBi , so the power limit shall be reduced to "Determined Conducted Limit-(11.55-6)".

For U-NII-3 Band: Directional gain = $10 \log[(10^{G1/20} + 10^{G2/20} + \dots + 10^{GN/20})^2/4]$ = 11.81dBi > 6dBi , so the power limit shall be reduced to 30-(11.81-6) = 24.19dBm.

26dB Bandwidth:

Chan.	Freq. (MHz)	26dBc Bandwidth (MHz)				Pass / Fail
		Chain 0	Chain 1	Chain 2	Chain 3	
52	5260	22.09	21.48	22.10	21.89	Pass
60	5300	22.16	21.73	21.89	21.65	Pass
64	5320	22.01	21.79	21.90	22.00	Pass
100	5500	21.97	21.62	21.85	21.80	Pass
116	5580	21.88	21.62	21.82	21.80	Pass
140	5700	21.94	21.60	21.66	21.74	Pass
144	5720 For U-NII-2C	16.17	15.89	15.97	15.97	Pass
144	5720 For U-NII-3	6.19	5.97	5.77	5.99	Pass

Note: For FCC output power limitation is determined based on 26dB bandwidth.

Power Limit = 11 dBm+10 log B <U-NII-2A, U-NII-2C>

Chan.	Freq. (MHz)	Min. B (MHz)	Determined Conducted Limit (dBm)
52	5260	21.48	24.32 > 24
60	5300	21.65	24.35 > 24
64	5320	21.79	24.38 > 24
100	5500	21.62	24.34 > 24
116	5580	21.62	24.34 > 24
140	5700	21.60	24.34 > 24
144	5720 For U-NII-2C	15.89	23.01 < 24

802.11ac (VHT40)

Power Output:

Chan.	Freq. (MHz)	Maximum Conducted Power (dBm)				Total Power (mW)	Total Power (dBm)	Power Limit (dBm)	Pass / Fail
		Chain 0	Chain 1	Chain 2	Chain 3				
54	5270	12.62	12.64	12.12	11.63	67.494	18.29	18.31	Pass
62	5310	12.10	12.15	11.66	11.15	60.311	17.80	18.31	Pass
102	5510	12.52	12.23	12.49	12.16	68.762	18.37	18.45	Pass
110	5550	12.50	12.32	12.46	12.22	69.136	18.40	18.45	Pass
134	5670	12.52	12.29	12.50	12.19	69.149	18.40	18.45	Pass
142	5710 For U-NII-2C	9.57	9.48	9.69	9.75	36.681	15.64	18.45	Pass
142	5710 For U-NII-3	-0.83	-0.97	-1.21	-0.92	3.1917	5.04	24.19	Pass

Note:

For U-NII-2A Band: Directional gain = $10 \log[(10^{G1/20} + 10^{G2/20} + \dots + 10^{GN/20})^2/4]$ = 11.69dBi > 6dBi , so the power limit shall be reduced to "Determined Conducted Limit-(11.69-6)".

For U-NII-2C Band: Directional gain = $10 \log[(10^{G1/20} + 10^{G2/20} + \dots + 10^{GN/20})^2/4]$ = 11.55dBi > 6dBi , so the power limit shall be reduced to "Determined Conducted Limit-(11.55-6)".

For U-NII-3 Band: Directional gain = $10 \log[(10^{G1/20} + 10^{G2/20} + \dots + 10^{GN/20})^2/4]$ = 11.81dBi > 6dBi , so the power limit shall be reduced to $30-(11.81-6) = 24.19$ dBm.

26dB Bandwidth:

Chan.	Freq. (MHz)	26dBc Bandwidth (MHz)				Pass / Fail
		Chain 0	Chain 1	Chain 2	Chain 3	
54	5270	68.22	61.75	53.07	49.00	Pass
62	5310	41.69	45.18	41.58	41.24	Pass
102	5510	47.53	41.46	41.30	41.35	Pass
110	5550	67.23	52.72	64.11	49.80	Pass
134	5670	64.90	57.93	55.93	50.62	Pass
142	5710 For U-NII-2C	50.22	45.52	47.60	47.09	Pass
142	5710 For U-NII-3	20.82	20.62	18.46	19.10	Pass

Note: For FCC output power limitation is determined based on 26dB bandwidth.

Power Limit = 11 dBm+10 log B <U-NII-2A, U-NII-2C>

Chan.	Freq. (MHz)	Min. B (MHz)	Determined Conducted Limit (dBm)
54	5270	49.00	27.90 > 24
62	5310	41.24	27.15 > 24
102	5510	41.30	27.15 > 24
110	5550	49.80	27.97 > 24
134	5670	50.62	28.04 > 24
142	5710 For U-NII-2C	45.52	27.58 > 24

802.11ac (VHT80)

Power Output:

Chan.	Freq. (MHz)	Maximum Conducted Power (dBm)				Total Power (mW)	Total Power (dBm)	Power Limit (dBm)	Pass / Fail
		Chain 0	Chain 1	Chain 2	Chain 3				
58	5290	10.21	9.32	9.54	9.99	38.018	15.80	18.31	Pass
106	5530	10.89	10.25	10.72	10.36	45.534	16.58	18.45	Pass
122	5610	12.49	12.33	12.46	12.24	69.211	18.40	18.45	Pass
138	5690 For U-NII-2C	9.70	9.54	9.61	9.74	38.412	15.84	18.45	Pass
138	5690 For U-NII-3	-4.20	-4.46	-4.98	-4.37	1.480	1.70	24.19	Pass

Note:

For U-NII-2A Band: Directional gain = $10 \log[(10^{G1/20} + 10^{G2/20} + \dots + 10^{GN/20})^2/4] = 11.69\text{dBi} > 6\text{dBi}$, so the power limit shall be reduced to "Determined Conducted Limit-(11.69-6)".

For U-NII-2C Band: Directional gain = $10 \log[(10^{G1/20} + 10^{G2/20} + \dots + 10^{GN/20})^2/4] = 11.55\text{dBi} > 6\text{dBi}$, so the power limit shall be reduced to "Determined Conducted Limit-(11.55-6)".

For U-NII-3 Band: Directional gain = $10 \log[(10^{G1/20} + 10^{G2/20} + \dots + 10^{GN/20})^2/4] = 11.81\text{dBi} > 6\text{dBi}$, so the power limit shall be reduced to $30 - (11.81 - 6) = 24.19\text{dBm}$.

26dB Bandwidth:

Chan.	Freq. (MHz)	26dBc Bandwidth (MHz)				Pass / Fail
		Chain 0	Chain 1	Chain 2	Chain 3	
58	5290	82.89	82.39	82.16	82.13	Pass
106	5530	83.18	82.80	82.30	82.27	Pass
122	5610	140.44	133.17	126.56	119.70	Pass
138	5690 For U-NII-2C	106.31	101.38	103.22	104.72	Pass
138	5690 For U-NII-3	42.36	31.28	29.98	29.08	Pass

Note: For FCC output power limitation is determined based on 26dB bandwidth.

Power Limit = 11 dBm+10 log B <U-NII-2A, U-NII-2C>			
Chan.	Freq. (MHz)	Min. B (MHz)	Determined Conducted Limit (dBm)
58	5290	82.13	30.14 > 24
106	5530	82.27	30.15 > 24
122	5610	119.70	31.78 > 24
138	5690 For U-NII-2C	101.38	31.05 > 24

Spectrum Plot of Worst Value

802.11ac (VHT20)

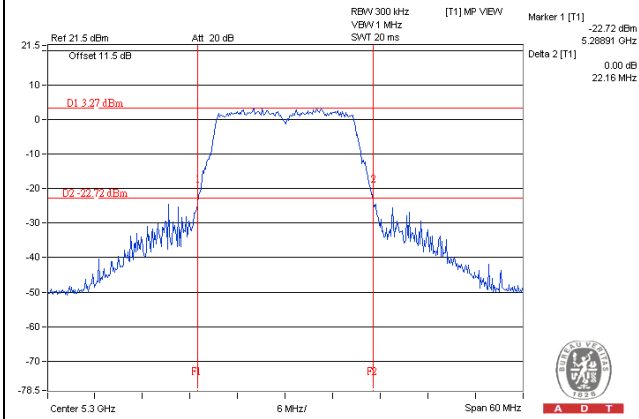

802.11ac (VHT40)

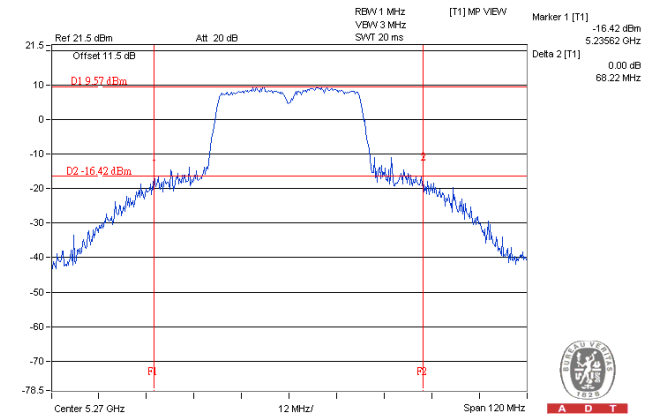

802.11ac (VHT80)

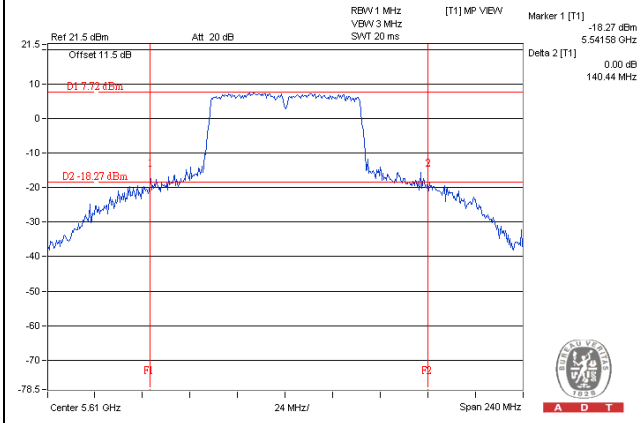

Radio 1 - 2TX CDD Mode

802.11a

Power Output:

Chan.	Freq. (MHz)	Maximum Conducted Power (dBm)		Total Power (mW)	Total Power (dBm)	Power Limit (dBm)	Pass / Fail
		Chain 0	Chain 3				
52	5260	18.42	17.65	127.712	21.06	24.00	Pass
60	5300	18.38	17.69	127.614	21.06	24.00	Pass
64	5320	18.38	17.67	127.344	21.05	24.00	Pass

Chan.	Freq. (MHz)	Maximum Conducted Power (dBm)		Total Power (mW)	Total Power (dBm)	Power Limit (dBm)	Pass / Fail
		Chain 1	Chain 3				
100	5500	18.49	17.86	131.726	21.20	24.00	Pass
116	5580	18.52	17.77	130.962	21.17	24.00	Pass
140	5700	18.37	17.96	131.224	21.18	24.00	Pass
144	5720 For U-NII-2C	14.93	14.39	58.596	17.68	24.00	Pass
144	5720 For U-NII-3	8.74	8.01	13.806	11.40	30.00	Pass

26dB Bandwidth:

Chan.	Freq. (MHz)	26dBc Bandwidth (MHz)		Pass / Fail
		Chain 0	Chain 3	
52	5260	33.11	32.31	Pass
60	5300	33.25	31.93	Pass
64	5320	32.96	31.59	Pass

Chan.	Freq. (MHz)	26dBc Bandwidth (MHz)		Pass / Fail
		Chain 1	Chain 3	
100	5500	33.28	32.97	Pass
116	5580	33.07	32.95	Pass
140	5700	32.93	32.31	Pass
144	5720 For U-NII-2C	21.80	21.68	Pass
144	5720 For U-NII-3	13.00	11.31	Pass

Note: For FCC output power limitation is determined based on 26dB bandwidth.

Power Limit = 11 dBm+10 log B <U-NII-2A, U-NII-2C>

Chan.	Freq. (MHz)	Min. B (MHz)	Determined Conducted Limit (dBm)
52	5260	32.31	26.09 > 24
60	5300	31.93	26.04 > 24
64	5320	31.59	25.99 > 24
100	5500	32.97	26.18 > 24
116	5580	32.95	26.17 > 24
140	5700	32.31	26.09 > 24
144	5720 For U-NII-2C	21.68	24.36 > 24

802.11ac (VHT20)

Power Output:

Chan.	Freq. (MHz)	Maximum Conducted Power (dBm)		Total Power (mW)	Total Power (dBm)	Power Limit (dBm)	Pass / Fail
		Chain 0	Chain 3				
52	5260	18.33	17.62	125.887	21.00	24.00	Pass
60	5300	18.42	17.65	127.712	21.06	24.00	Pass
64	5320	18.29	17.62	125.263	20.98	24.00	Pass

Chan.	Freq. (MHz)	Maximum Conducted Power (dBm)		Total Power (mW)	Total Power (dBm)	Power Limit (dBm)	Pass / Fail
		Chain 1	Chain 3				
100	5500	18.52	17.82	131.655	21.19	24.00	Pass
116	5580	18.54	17.86	132.544	21.22	24.00	Pass
140	5700	17.28	17.02	103.806	20.16	24.00	Pass
144	5720 For U-NII-2C	14.69	14.19	55.686	17.46	24.00	Pass
144	5720 For U-NII-3	8.95	8.35	14.691	11.67	30.00	Pass

26dB Bandwidth:

Chan.	Freq. (MHz)	26dBc Bandwidth (MHz)		Pass / Fail
		Chain 0	Chain 3	
52	5260	35.63	34.99	Pass
60	5300	35.28	35.95	Pass
64	5320	35.74	35.35	Pass

Chan.	Freq. (MHz)	26dBc Bandwidth (MHz)		Pass / Fail
		Chain 1	Chain 3	
100	5500	35.49	37.45	Pass
116	5580	36.27	35.64	Pass
140	5700	34.67	34.02	Pass
144	5720 For U-NII-2C	23.56	23.77	Pass
144	5720 For U-NII-3	14.94	14.45	Pass

Note: For FCC output power limitation is determined based on 26dB bandwidth.

Power Limit = 11 dBm+10 log B <U-NII-2A, U-NII-2C>

Chan.	Freq. (MHz)	Min. B (MHz)	Determined Conducted Limit (dBm)
52	5260	34.99	26.43 > 24
60	5300	35.28	26.47 > 24
64	5320	35.35	26.48 > 24
100	5500	35.49	26.50 > 24
116	5580	35.64	26.51 > 24
140	5700	34.02	26.31 > 24
144	5720 For U-NII-2C	23.56	24.72 > 24

802.11ac (VHT40)

Power Output:

Chan.	Freq. (MHz)	Maximum Conducted Power (dBm)		Total Power (mW)	Total Power (dBm)	Power Limit (dBm)	Pass / Fail
		Chain 0	Chain 3				
54	5270	20.76	19.88	216.399	23.35	24.00	Pass
62	5310	13.45	12.67	40.624	16.09	24.00	Pass

Chan.	Freq. (MHz)	Maximum Conducted Power (dBm)		Total Power (mW)	Total Power (dBm)	Power Limit (dBm)	Pass / Fail
		Chain 1	Chain 3				
102	5510	14.57	14.50	56.826	17.55	24.00	Pass
110	5550	20.09	20.29	208.999	23.20	24.00	Pass
134	5670	18.48	18.64	143.583	21.57	24.00	Pass
142	5710 For U-NII-2C	17.89	17.48	117.494	20.70	24.00	Pass
142	5710 For U-NII-3	7.83	7.31	11.450	10.59	30.00	Pass

26dB Bandwidth:

Chan.	Freq. (MHz)	26dBc Bandwidth (MHz)		Pass / Fail
		Chain 0	Chain 3	
54	5270	99.24	94.42	Pass
62	5310	41.61	41.30	Pass

Chan.	Freq. (MHz)	26dBc Bandwidth (MHz)		Pass / Fail
		Chain 1	Chain 3	
102	5510	49.90	50.34	Pass
110	5550	93.82	94.12	Pass
134	5670	83.77	82.23	Pass
142	5710 For U-NII-2C	63.06	64.92	Pass
142	5710 For U-NII-3	34.63	34.22	Pass

Note: For FCC output power limitation is determined based on 26dB bandwidth.

Power Limit = $11 \text{ dBm} + 10 \log B$ <U-NII-2A, U-NII-2C>

Chan.	Freq. (MHz)	Min. B (MHz)	Determined Conducted Limit (dBm)
54	5270	94.42	30.75 > 24
62	5310	41.30	27.15 > 24
102	5510	49.90	27.98 > 24
110	5550	93.82	30.72 > 24
134	5670	82.23	30.15 > 24
142	5710 For U-NII-2C	63.06	28.99 > 24

802.11ac (VHT80)

Power Output:

Chan.	Freq. (MHz)	Maximum Conducted Power (dBm)		Total Power (mW)	Total Power (dBm)	Power Limit (dBm)	Pass / Fail
		Chain 0	Chain 3				
58	5290	12.32	11.88	32.302	15.09	24.00	Pass

Chan.	Freq. (MHz)	Maximum Conducted Power (dBm)		Total Power (mW)	Total Power (dBm)	Power Limit (dBm)	Pass / Fail
		Chain 1	Chain 3				
106	5530	12.39	12.62	35.619	15.52	24.00	Pass
122	5610	18.20	18.42	135.571	21.32	24.00	Pass
138	5690 For U-NII-2C	16.66	15.12	87.305	19.41	24.00	Pass
138	5690 For U-NII-3	3.15	13.70	3.771	5.76	30.00	Pass

26dB Bandwidth:

Chan.	Freq. (MHz)	26dBc Bandwidth (MHz)		Pass / Fail
		Chain 0	Chain 3	
58	5290	82.64	82.50	Pass

Chan.	Freq. (MHz)	26dBc Bandwidth (MHz)		Pass / Fail
		Chain 1	Chain 3	
106	5530	82.99	82.27	Pass
122	5610	159.74	156.83	Pass
138	5690 For U-NII-2C	120.89	105.47	Pass
138	5690 For U-NII-3	56.24	36.02	Pass

Note: For FCC output poer limitation is determined based on 26dB bandwidth.

Power Limit = 11 dBm+10 log B <U-NII-2A, U-NII-2C>			
Chan.	Freq. (MHz)	Min. B (MHz)	Determined Conducted Limit (dBm)
58	5290	82.50	30.16 > 24
106	5530	82.27	30.15 > 24
122	5610	156.83	32.95 > 24
138	5690 For U-NII-2C	105.47	31.23 > 24

Spectrum Plot of Worst Value

802.11a

802.11ac (VHT20)

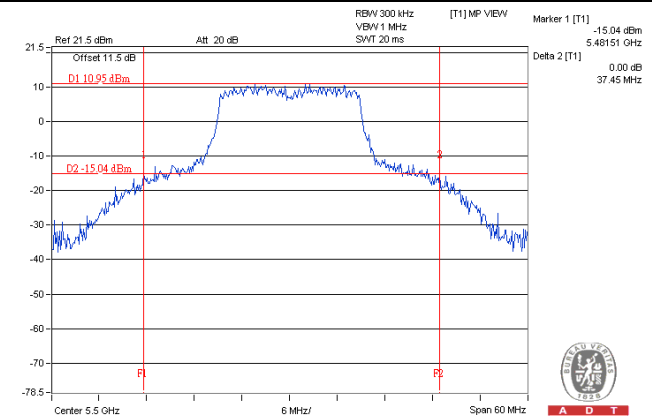
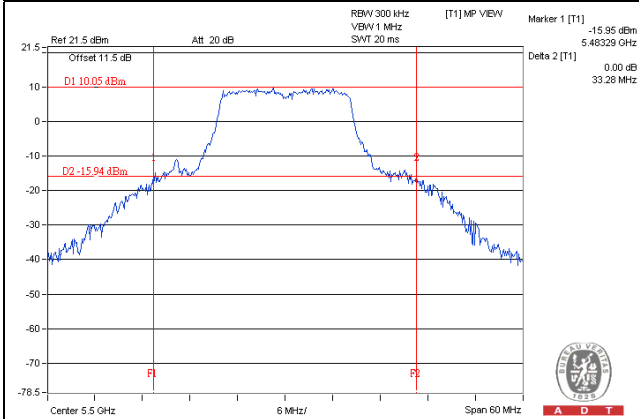

802.11ac (VHT40)

802.11ac (VHT80)

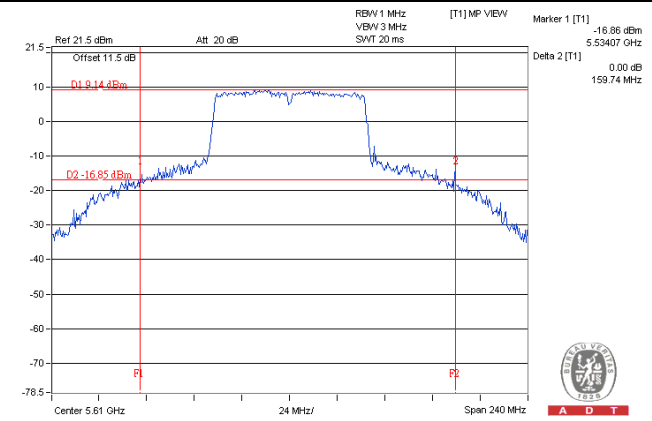
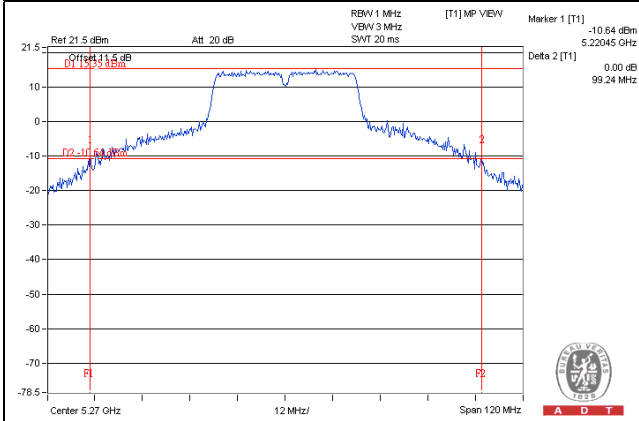

Radio 1 - 2TX TxBF Mode

802.11ac (VHT20)

Power Output:

Chan.	Freq. (MHz)	Maximum Conducted Power (dBm)		Total Power (mW)	Total Power (dBm)	Power Limit (dBm)	Pass / Fail
		Chain 0	Chain 3				
52	5260	18.33	17.62	125.887	21.00	21.07	Pass
60	5300	18.42	17.65	127.712	21.06	21.07	Pass
64	5320	18.29	17.62	125.263	20.98	21.07	Pass

Chan.	Freq. (MHz)	Maximum Conducted Power (dBm)		Total Power (mW)	Total Power (dBm)	Power Limit (dBm)	Pass / Fail
		Chain 1	Chain 3				
100	5500	18.52	17.82	131.655	21.19	21.23	Pass
116	5580	18.54	17.86	132.544	21.22	21.23	Pass
140	5700	17.28	17.02	103.806	20.16	21.23	Pass
144	5720 For U-NII-2C	14.69	14.19	55.686	17.46	21.23	Pass
144	5720 For U-NII-3	8.95	8.35	14.691	11.67	27.17	Pass

Note:

For U-NII-2A Band: Directional gain = $10 \log[(10^{G1/20} + 10^{G2/20} + \dots + 10^{GN/20})^2/2] = 8.93\text{dBi} > 6\text{dBi}$, so the power limit shall be reduced to "Determined Conducted Limit-(8.93-6)".

For U-NII-2C Band: Directional gain = $10 \log[(10^{G1/20} + 10^{G2/20} + \dots + 10^{GN/20})^2/2] = 8.77\text{dBi} > 6\text{dBi}$, so the power limit shall be reduced to "Determined Conducted Limit-(8.77-6)".

For U-NII-3 Band: Directional gain = $10 \log[(10^{G1/20} + 10^{G2/20} + \dots + 10^{GN/20})^2/2] = 8.83\text{dBi} > 6\text{dBi}$, so the power density limit shall be reduced to $30 - (8.83 - 6) = 27.17\text{dBm}$.

26dB Bandwidth:

Chan.	Freq. (MHz)	26dBc Bandwidth (MHz)		Pass / Fail
		Chain 0	Chain 3	
52	5260	35.63	34.99	Pass
60	5300	35.28	35.95	Pass
64	5320	35.74	35.35	Pass

Chan.	Freq. (MHz)	26dBc Bandwidth (MHz)		Pass / Fail
		Chain 1	Chain 3	
100	5500	35.49	37.45	Pass
116	5580	36.27	35.64	Pass
140	5700	34.67	34.02	Pass
144	5720 For U-NII-2C	23.56	23.77	Pass
144	5720 For U-NII-3	14.94	14.45	Pass

Note: For FCC output poer limitation is determined based on 26dB bandwidth.

Power Limit = 11 dBm+10 log B <U-NII-2A, U-NII-2C>			
Chan.	Freq. (MHz)	Min. B (MHz)	Determined Conducted Limit (dBm)
52	5260	34.99	26.43 > 24
60	5300	35.28	26.47 > 24
64	5320	35.35	26.48 > 24
100	5500	35.49	26.50 > 24
116	5580	35.64	26.51 > 24
140	5700	34.02	26.31 > 24
144	5720 For U-NII-2C	23.56	24.72 > 24

802.11ac (VHT40)

Power Output:

Chan.	Freq. (MHz)	Maximum Conducted Power (dBm)		Total Power (mW)	Total Power (dBm)	Power Limit (dBm)	Pass / Fail
		Chain 0	Chain 3				
54	5270	18.44	17.52	126.317	21.01	21.07	Pass
62	5310	13.45	12.67	40.624	16.09	21.07	Pass

Chan.	Freq. (MHz)	Maximum Conducted Power (dBm)		Total Power (mW)	Total Power (dBm)	Power Limit (dBm)	Pass / Fail
		Chain 1	Chain 3				
102	5510	14.57	14.50	56.826	17.55	21.23	Pass
110	5550	18.11	18.25	131.548	21.19	21.23	Pass
134	5670	18.06	18.30	131.581	21.19	21.23	Pass
142	5710 For U-NII-2C	15.47	15.47	70.474	18.48	21.23	Pass
142	5710 For U-NII-3	5.06	4.96	6.339	8.02	27.17	Pass

Note:

For U-NII-2A Band: Directional gain = $10 \log[(10^{G1/20} + 10^{G2/20} + \dots + 10^{GN/20})^2/2] = 8.93\text{dBi} > 6\text{dBi}$, so the power limit shall be reduced to "Determined Conducted Limit-(8.93-6)".

For U-NII-2C Band: Directional gain = $10 \log[(10^{G1/20} + 10^{G2/20} + \dots + 10^{GN/20})^2/2] = 8.77\text{dBi} > 6\text{dBi}$, so the power limit shall be reduced to "Determined Conducted Limit-(8.77-6)".

For U-NII-3 Band: Directional gain = $10 \log[(10^{G1/20} + 10^{G2/20} + \dots + 10^{GN/20})^2/2] = 8.83\text{dBi} > 6\text{dBi}$, so the power density limit shall be reduced to $30 - (8.83 - 6) = 27.17\text{dBm}$.

26dB Bandwidth:

Chan.	Freq. (MHz)	26dBc Bandwidth (MHz)		Pass / Fail
		Chain 0	Chain 3	
54	5270	99.24	94.42	Pass
62	5310	41.61	41.30	Pass

Chan.	Freq. (MHz)	26dBc Bandwidth (MHz)		Pass / Fail
		Chain 1	Chain 3	
102	5510	49.90	50.34	Pass
110	5550	93.82	94.12	Pass
134	5670	83.77	82.23	Pass
142	5710 For U-NII-2C	63.06	64.92	Pass
142	5710 For U-NII-3	34.63	34.22	Pass

Note: For FCC output power limitation is determined based on 26dB bandwidth.

Power Limit = 11 dBm+10 log B <U-NII-2A, U-NII-2C>

Chan.	Freq. (MHz)	Min. B (MHz)	Determined Conducted Limit (dBm)
54	5270	94.42	30.75 > 24
62	5310	41.30	27.15 > 24
102	5510	49.90	27.98 > 24
110	5550	93.82	30.72 > 24
134	5670	82.23	30.15 > 24
142	5710 For U-NII-2C	63.06	28.99 > 24

802.11ac (VHT80)

Power Output:

Chan.	Freq. (MHz)	Maximum Conducted Power (dBm)		Total Power (mW)	Total Power (dBm)	Power Limit (dBm)	Pass / Fail
		Chain 0	Chain 3				
58	5290	12.32	11.83	32.302	15.09	21.07	Pass

Chan.	Freq. (MHz)	Maximum Conducted Power (dBm)		Total Power (mW)	Total Power (dBm)	Power Limit (dBm)	Pass / Fail
		Chain 1	Chain 3				
106	5530	12.39	12.62	35.619	15.52	21.23	Pass
122	5610	18.06	18.16	129.437	21.12	21.23	Pass
138	5690 For U-NII-2C	15.84	15.98	81.221	19.10	21.23	Pass
138	5690 For U-NII-3	15.32	1.98	37.09	15.69	27.17	Pass

Note:

For U-NII-2A Band: Directional gain = $10 \log[(10^{G1/20} + 10^{G2/20} + \dots + 10^{GN/20})^2/2]$ = 8.93dBi > 6dBi , so the power limit shall be reduced to "Determined Conducted Limit-(8.93-6)".

For U-NII-2C Band: Directional gain = $10 \log[(10^{G1/20} + 10^{G2/20} + \dots + 10^{GN/20})^2/2]$ = 8.77dBi > 6dBi , so the power limit shall be reduced to "Determined Conducted Limit-(8.77-6)".

For U-NII-3 Band: Directional gain = $10 \log[(10^{G1/20} + 10^{G2/20} + \dots + 10^{GN/20})^2/2]$ = 8.83dBi > 6dBi , so the power density limit shall be reduced to 30-(8.83-6) = 27.17dBm.

26dB Bandwidth:

Chan.	Freq. (MHz)	26dBc Bandwidth (MHz)		Pass / Fail
		Chain 0	Chain 3	
58	5290	82.64	82.50	Pass

Chan.	Freq. (MHz)	26dBc Bandwidth (MHz)		Pass / Fail
		Chain 1	Chain 3	
106	5530	82.99	82.27	Pass
122	5610	159.74	156.83	Pass
138	5690 For U-NII-2C	120.89	105.47	Pass
138	5690 For U-NII-3	56.24	36.02	Pass

Note: For FCC output power limitation is determined based on 26dB bandwidth.

Power Limit = 11 dBm+10 log B <U-NII-2A, U-NII-2C>

Chan.	Freq. (MHz)	Min. B (MHz)	Determined Conducted Limit (dBm)
58	5290	82.50	30.16 > 24
106	5530	82.27	30.15 > 24
122	5610	156.83	32.95 > 24
138	5690 For U-NII-2C	105.47	31.23 > 24

Spectrum Plot of Worst Value

802.11ac (VHT20)

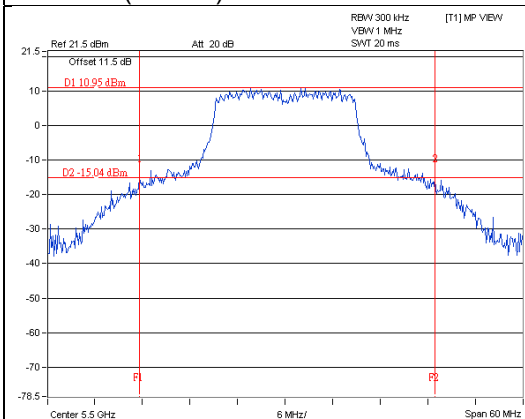

802.11ac (VHT40)

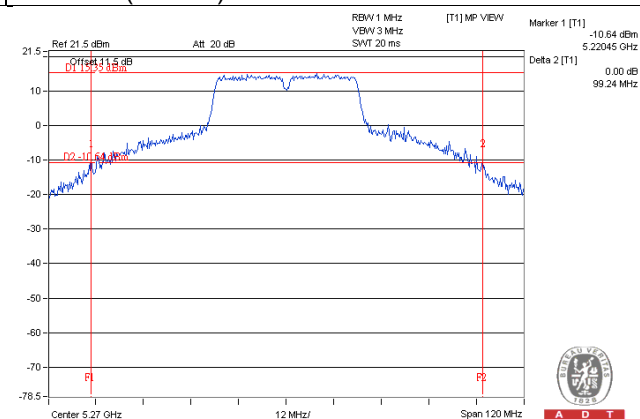

802.11ac (VHT80)

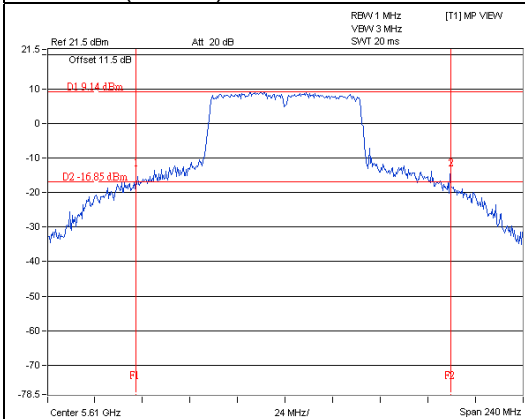

Radio 2 - 4TX CDD Mode

802.11a

Power Output:

Chan.	Freq. (MHz)	Maximum Conducted Power (dBm)				Total Power (mW)	Total Power (dBm)	Power Limit (dBm)	Pass / Fail
		Chain 0	Chain 1	Chain 2	Chain 3				
52	5260	12.55	12.15	12.08	11.66	65.194	18.14	24.00	Pass
60	5300	12.67	12.52	11.64	11.57	65.301	18.15	24.00	Pass
64	5320	12.51	12.27	11.91	11.72	65.073	18.13	24.00	Pass
100	5500	13.05	11.98	11.91	11.81	66.655	18.24	24.00	Pass
116	5580	13.02	11.90	12.38	11.87	68.213	18.34	24.00	Pass
140	5700	13.10	12.19	12.16	11.80	68.555	18.36	24.00	Pass
144	5720 For U-NII-2C	9.34	8.73	8.44	8.67	30.398	14.83	22.97	Pass
144	5720 For U-NII-3	3.11	2.31	2.21	2.53	7.202	8.57	30.00	Pass

26dB Bandwidth:

Chan.	Freq. (MHz)	26dBc Bandwidth (MHz)				Pass / Fail
		Chain 0	Chain 1	Chain 2	Chain 3	
52	5260	21.75	21.61	21.62	21.51	Pass
60	5300	21.86	21.70	21.67	21.48	Pass
64	5320	21.83	21.69	21.65	21.60	Pass
100	5500	21.70	21.70	21.54	21.43	Pass
116	5580	21.62	21.61	21.62	21.51	Pass
140	5700	21.72	21.65	21.63	21.55	Pass
144	5720 For U-NII-2C	15.89	15.89	15.77	15.80	Pass
144	5720 For U-NII-3	5.81	5.84	5.79	5.74	Pass

Note: For FCC output power limitation is determined based on 26dB bandwidth.

Power Limit = $11 \text{ dBm} + 10 \log B$ <U-NII-2A, U-NII-2C>

Chan.	Freq. (MHz)	Min. B (MHz)	Determined Conducted Limit (dBm)
52	5260	21.51	24.32 > 24
60	5300	21.48	24.32 > 24
64	5320	21.60	24.34 > 24
100	5500	21.43	24.31 > 24
116	5580	21.51	24.32 > 24
140	5700	21.55	24.33 > 24
144	5720 For U-NII-2C	15.77	22.97 < 24

802.11ac (VHT20)

Power Output:

Chan.	Freq. (MHz)	Maximum Conducted Power (dBm)				Total Power (mW)	Total Power (dBm)	Power Limit (dBm)	Pass / Fail
		Chain 0	Chain 1	Chain 2	Chain 3				
52	5260	12.38	12.40	11.61	11.49	63.257	18.01	24.00	Pass
60	5300	12.60	12.61	12.10	11.46	66.650	18.24	24.00	Pass
64	5320	12.56	12.56	12.14	11.56	66.750	18.24	24.00	Pass
100	5500	12.94	11.98	11.66	11.65	64.732	18.11	24.00	Pass
116	5580	12.98	11.82	12.28	11.77	67.001	18.26	24.00	Pass
140	5700	13.03	12.22	12.15	11.86	68.515	18.36	24.00	Pass
144	5720 For U-NII-2C	9.70	8.54	8.41	8.47	30.443	14.83	23.01	Pass
144	5720 For U-NII-3	3.89	2.75	2.65	2.72	8.045	9.06	30.00	Pass

26dB Bandwidth:

Chan.	Freq. (MHz)	26dBc Bandwidth (MHz)				Pass / Fail
		Chain 0	Chain 1	Chain 2	Chain 3	
52	5260	22.06	21.56	21.68	21.46	Pass
60	5300	21.99	21.67	21.49	21.77	Pass
64	5320	21.90	21.52	21.65	21.67	Pass
100	5500	22.14	21.65	21.81	21.74	Pass
116	5580	21.90	21.72	21.86	21.70	Pass
140	5700	21.87	21.71	22.02	21.76	Pass
144	5720 For U-NII-2C	16.05	15.92	15.89	15.96	Pass
144	5720 For U-NII-3	5.95	5.77	6.00	5.87	Pass

Note: For FCC output power limitation is determined based on 26dB bandwidth.

Power Limit = 11 dBm+10 log B <U-NII-2A, U-NII-2C>

Chan.	Freq. (MHz)	Min. B (MHz)	Determined Conducted Limit (dBm)
52	5260	21.46	24.31 > 24
60	5300	21.49	24.32 > 24
64	5320	21.52	24.32 > 24
100	5500	21.65	24.35 > 24
116	5580	21.70	24.36 > 24
140	5700	21.71	24.36 > 24
144	5720 For U-NII-2C	15.89	23.01 < 24

802.11ac (VHT40)

Power Output:

Chan.	Freq. (MHz)	Maximum Conducted Power (dBm)				Total Power (mW)	Total Power (dBm)	Power Limit (dBm)	Pass / Fail
		Chain 0	Chain 1	Chain 2	Chain 3				
54	5270	15.90	15.43	15.90	13.90	137.271	21.38	24.00	Pass
62	5310	15.49	15.08	15.45	13.63	125.753	21.00	24.00	Pass
102	5510	13.86	13.08	13.48	11.98	82.706	19.18	24.00	Pass
110	5550	15.83	14.88	15.67	14.26	132.610	21.23	24.00	Pass
134	5670	15.77	14.86	15.72	14.31	132.679	21.23	24.00	Pass
142	5710 For U-NII-2C	13.05	12.18	12.75	11.69	70.297	18.47	24.00	Pass
142	5710 For U-NII-3	2.44	1.69	2.31	1.19	6.247	7.96	30.00	Pass

26dB Bandwidth:

Chan.	Freq. (MHz)	26dBc Bandwidth (MHz)				Pass / Fail
		Chain 0	Chain 1	Chain 2	Chain 3	
54	5270	58.99	45.26	66.56	40.99	Pass
62	5310	41.68	41.45	63.88	49.34	Pass
102	5510	41.51	41.40	50.16	41.13	Pass
110	5550	41.70	41.52	65.51	57.64	Pass
134	5670	58.52	55.26	75.02	65.04	Pass
142	5710 For U-NII-2C	45.47	45.21	46.40	44.26	Pass
142	5710 For U-NII-3	15.01	15.42	16.66	6.08	Pass

Note: For FCC output power limitation is determined based on 26dB bandwidth.

Power Limit = 11 dBm+10 log B <U-NII-2A, U-NII-2C>			
Chan.	Freq. (MHz)	Min. B (MHz)	Determined Conducted Limit (dBm)
54	5270	40.99	27.12 > 24
62	5310	41.45	27.17 > 24
102	5510	41.13	27.14 > 24
110	5550	41.52	27.18 > 24
134	5670	55.26	28.42 > 24
142	5710 For U-NII-2C	44.26	27.46 > 24

802.11ac (VHT80)

Power Output:

Chan.	Freq. (MHz)	Maximum Conducted Power (dBm)				Total Power (mW)	Total Power (dBm)	Power Limit (dBm)	Pass / Fail
		Chain 0	Chain 1	Chain 2	Chain 3				
58	5290	11.85	11.18	11.60	10.74	54.745	17.38	24.00	Pass
106	5530	11.80	11.25	11.65	10.86	55.283	17.43	24.00	Pass
122	5610	18.63	17.60	18.45	16.67	246.926	23.93	24.00	Pass
138	5690 For U-NII-2C	15.27	14.68	15.10	14.89	131.431	21.19	24.00	Pass
138	5690 For U-NII-3	1.26	0.79	1.32	1.10	5.393	7.32	30.00	Pass

26dB Bandwidth:

Chan.	Freq. (MHz)	26dBc Bandwidth (MHz)				Pass / Fail
		Chain 0	Chain 1	Chain 2	Chain 3	
58	5290	148.73	144.20	196.45	167.03	Pass
106	5530	113.07	94.14	123.82	102.19	Pass
122	5610	194.21	194.20	189.72	168.97	Pass
138	5690 For U-NII-2C	132.01	133.08	130.06	128.90	Pass
138	5690 For U-NII-3	43.37	40.46	29.43	30.29	Pass

Note: For FCC output poer limitation is determined based on 26dB bandwidth.

Power Limit = 11 dBm+10 log B <U-NII-2A, U-NII-2C>			
Chan.	Freq. (MHz)	Min. B (MHz)	Determined Conducted Limit (dBm)
58	5290	144.20	32.58 > 24
106	5530	94.14	30.73 > 24
122	5610	168.97	33.27 > 24
138	5690 For U-NII-2C	128.90	32.10 > 24

Spectrum Plot of Worst Value

802.11a

802.11ac (VHT20)

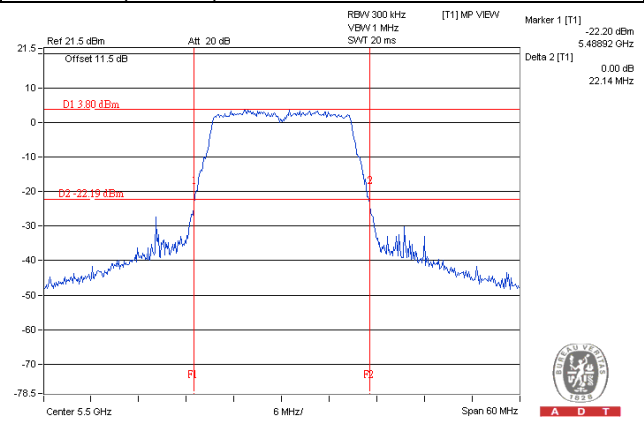
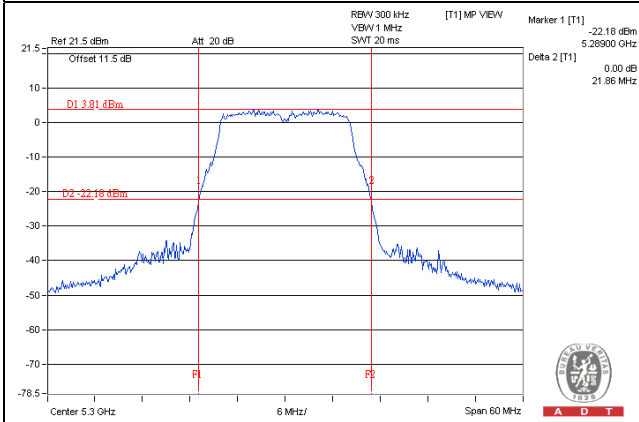

802.11ac (VHT40)

802.11ac (VHT80)

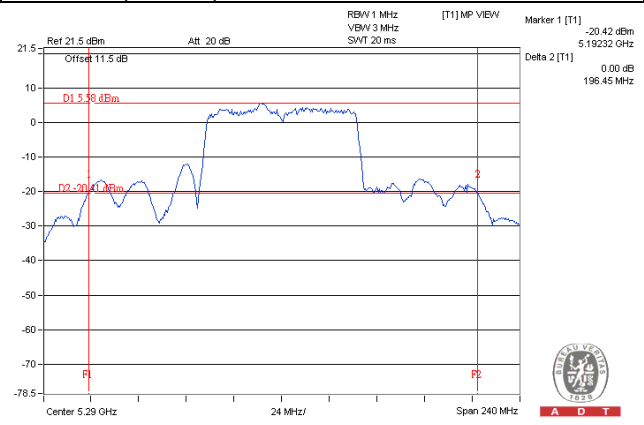
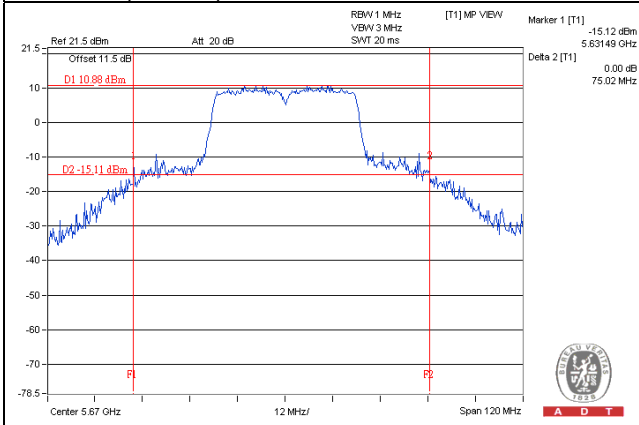

Radio 2 - 4TX TxBF Mode

802.11ac (VHT20)

Power Output:

Chan.	Freq. (MHz)	Maximum Conducted Power (dBm)				Total Power (mW)	Total Power (dBm)	Power Limit (dBm)	Pass / Fail
		Chain 0	Chain 1	Chain 2	Chain 3				
52	5260	12.38	12.40	11.61	11.49	63.257	18.01	18.42	Pass
60	5300	12.60	12.61	12.10	11.46	66.650	18.24	18.42	Pass
64	5320	12.56	12.56	12.14	11.56	66.750	18.24	18.42	Pass
100	5500	12.94	11.98	11.66	11.65	64.732	18.11	18.38	Pass
116	5580	12.98	11.82	12.28	11.77	67.001	18.26	18.38	Pass
140	5700	13.03	12.22	12.15	11.86	68.515	18.36	18.38	Pass
144	5720 For U-NII-2C	8.22	8.01	8.34	8.04	26.152	14.18	17.39	Pass
144	5720 For U-NII-3	2.55	2.25	2.58	2.30	6.987	8.44	24.30	Pass

Note:

For U-NII-2A Band: Directional gain = $10 \log[(10^{G1/20} + 10^{G2/20} + \dots + 10^{GN/20})^2/4]$ = 11.58dBi > 6dBi , so the power limit shall be reduced to "Determined Conducted Limit-(11.58-6)".

For U-NII-2C Band: Directional gain = $10 \log[(10^{G1/20} + 10^{G2/20} + \dots + 10^{GN/20})^2/4]$ = 11.62dBi > 6dBi , so the power limit shall be reduced to "Determined Conducted Limit-(11.62-6)".

For U-NII-3 Band: Directional gain = $10 \log[(10^{G1/20} + 10^{G2/20} + \dots + 10^{GN/20})^2/4]$ = 11.70dBi > 6dBi , so the power density limit shall be reduced to 30-(11.70-6) = 24.30dBm.

26dB Bandwidth:

Chan.	Freq. (MHz)	26dBc Bandwidth (MHz)				Pass / Fail
		Chain 0	Chain 1	Chain 2	Chain 3	
52	5260	22.06	21.56	21.68	21.46	Pass
60	5300	21.99	21.67	21.49	21.77	Pass
64	5320	21.90	21.52	21.65	21.67	Pass
100	5500	22.14	21.65	21.81	21.74	Pass
116	5580	21.90	21.72	21.86	21.70	Pass
140	5700	21.87	21.71	22.02	21.76	Pass
144	5720 For U-NII-2C	16.05	15.92	15.89	15.96	Pass
144	5720 For U-NII-3	5.95	5.77	6.00	5.87	Pass

Note: For FCC output power limitation is determined based on 26dB bandwidth.

Power Limit = $11 \text{ dBm} + 10 \log B$ <U-NII-2A, U-NII-2C>

Chan.	Freq. (MHz)	Min. B (MHz)	Determined Conducted Limit (dBm)
52	5260	21.46	24.31 > 24
60	5300	21.49	24.32 > 24
64	5320	21.52	24.32 > 24
100	5500	21.65	24.35 > 24
116	5580	21.70	24.36 > 24
140	5700	21.71	24.36 > 24
144	5720 For U-NII-2C	15.89	23.01 < 24

802.11ac (VHT40)

Power Output:

Chan.	Freq. (MHz)	Maximum Conducted Power (dBm)				Total Power (mW)	Total Power (dBm)	Power Limit (dBm)	Pass / Fail
		Chain 0	Chain 1	Chain 2	Chain 3				
54	5270	12.32	12.46	11.72	11.44	63.472	18.03	18.42	Pass
62	5310	12.42	12.32	11.74	11.38	63.187	18.01	18.42	Pass
102	5510	12.52	12.36	11.70	11.53	64.098	18.07	18.38	Pass
110	5550	12.49	12.40	11.76	11.49	64.210	18.08	18.38	Pass
134	5670	12.39	12.46	11.66	11.52	63.804	18.05	18.38	Pass
142	5710 For U-NII-2C	9.77	9.36	8.69	8.68	32.889	15.17	18.38	Pass
142	5710 For U-NII-3	-0.90	-1.05	-1.82	-1.82	2.9134	4.64	24.30	Pass

Note:

For U-NII-2A Band: Directional gain = $10 \log[(10^{G1/20} + 10^{G2/20} + \dots + 10^{GN/20})^2/4]$ = 11.58dBi > 6dBi , so the power limit shall be reduced to "Determined Conducted Limit-(11.58-6)".

For U-NII-2C Band: Directional gain = $10 \log[(10^{G1/20} + 10^{G2/20} + \dots + 10^{GN/20})^2/4]$ = 11.62dBi > 6dBi , so the power limit shall be reduced to "Determined Conducted Limit-(11.62-6)".

For U-NII-3 Band: Directional gain = $10 \log[(10^{G1/20} + 10^{G2/20} + \dots + 10^{GN/20})^2/4]$ = 11.70dBi > 6dBi , so the power density limit shall be reduced to 30-(11.70-6) = 24.30dBm.

26dB Bandwidth:

Chan.	Freq. (MHz)	26dBc Bandwidth (MHz)				Pass / Fail
		Chain 0	Chain 1	Chain 2	Chain 3	
54	5270	58.99	45.26	66.56	40.99	Pass
62	5310	41.68	41.45	63.88	49.34	Pass
102	5510	41.51	41.40	50.16	41.13	Pass
110	5550	41.70	41.52	65.51	57.64	Pass
134	5670	58.52	55.26	75.02	65.04	Pass
142	5710 For U-NII-2C	45.47	45.21	46.40	44.26	Pass
142	5710 For U-NII-3	15.01	15.42	16.66	6.08	Pass

Note: For FCC output power limitation is determined based on 26dB bandwidth.

Power Limit = 11 dBm+10 log B <U-NII-2A, U-NII-2C>

Chan.	Freq. (MHz)	Min. B (MHz)	Determined Conducted Limit (dBm)
54	5270	40.99	27.12 > 24
62	5310	41.45	27.17 > 24
102	5510	41.13	27.14 > 24
110	5550	41.52	27.18 > 24
134	5670	55.26	28.42 > 24
142	5710 For U-NII-2C	44.26	27.46 > 24

802.11ac (VHT80)

Power Output:

Chan.	Freq. (MHz)	Maximum Conducted Power (dBm)				Total Power (mW)	Total Power (dBm)	Power Limit (dBm)	Pass / Fail
		Chain 0	Chain 1	Chain 2	Chain 3				
58	5290	11.85	11.18	11.60	10.74	54.745	17.38	18.42	Pass
106	5530	11.80	11.25	11.65	10.86	55.283	17.43	18.38	Pass
122	5610	12.42	12.45	11.72	11.44	63.828	18.05	18.38	Pass
138	5690 For U-NII-2C	9.36	9.70	2.19	8.67	28.095	14.49	18.38	Pass
138	5690 For U-NII-3	-4.80	-4.31	-13.64	-5.28	1.08456	0.35	24.30	Pass

Note:

For U-NII-2A Band: Directional gain = $10 \log[(10^{G1/20} + 10^{G2/20} + \dots + 10^{GN/20})^2/4] = 11.58\text{dBi} > 6\text{dBi}$, so the power limit shall be reduced to "Determined Conducted Limit-(11.58-6)".

For U-NII-2C Band: Directional gain = $10 \log[(10^{G1/20} + 10^{G2/20} + \dots + 10^{GN/20})^2/4] = 11.62\text{dBi} > 6\text{dBi}$, so the power limit shall be reduced to "Determined Conducted Limit-(11.62-6)".

For U-NII-3 Band: Directional gain = $10 \log[(10^{G1/20} + 10^{G2/20} + \dots + 10^{GN/20})^2/4] = 11.70\text{dBi} > 6\text{dBi}$, so the power density limit shall be reduced to $30-(11.70-6) = 24.30\text{dBm}$.

26dB Bandwidth:

Chan.	Freq. (MHz)	26dBc Bandwidth (MHz)				Pass / Fail
		Chain 0	Chain 1	Chain 2	Chain 3	
58	5290	148.73	144.20	196.45	167.03	Pass
106	5530	113.07	94.14	123.82	102.19	Pass
122	5610	194.21	194.20	189.72	168.97	Pass
138	5690 For U-NII-2C	132.01	133.08	130.06	128.90	Pass
138	5690 For U-NII-3	43.37	40.46	29.43	30.29	Pass

Note: For FCC output power limitation is determined based on 26dB bandwidth.

Power Limit = 11 dBm+10 log B <U-NII-2A, U-NII-2C>			
Chan.	Freq. (MHz)	Min. B (MHz)	Determined Conducted Limit (dBm)
58	5290	144.20	32.58 > 24
106	5530	94.14	30.73 > 24
122	5610	168.97	33.27 > 24
138	5690 For U-NII-2C	128.90	32.10 > 24

Spectrum Plot of Worst Value

802.11ac (VHT20)

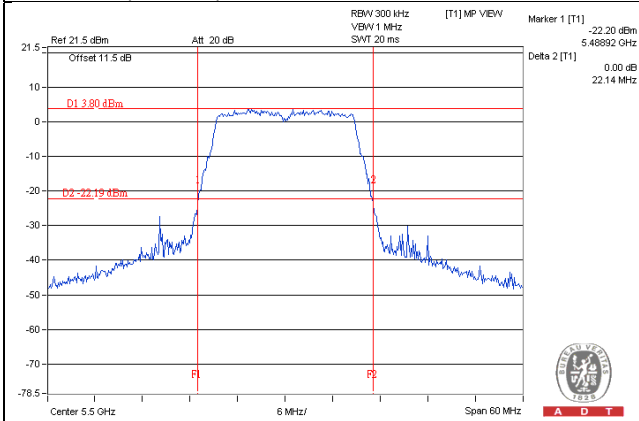

802.11ac (VHT40)

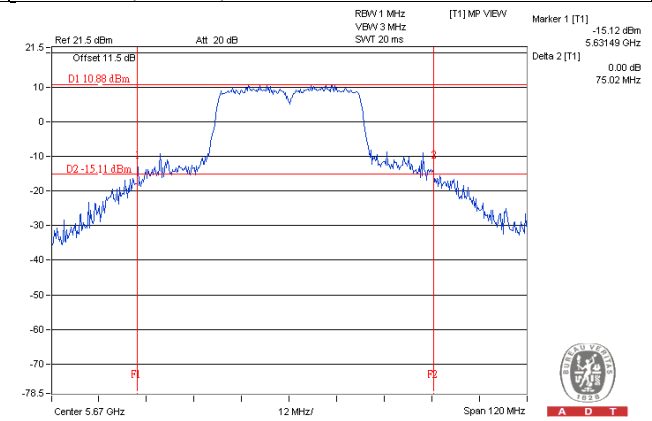

802.11ac (VHT80)

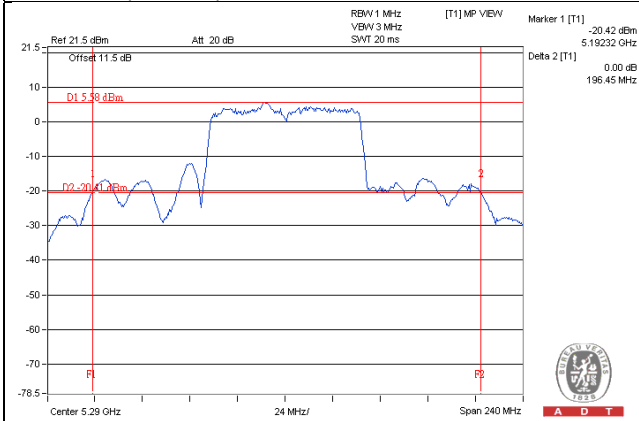

Radio 2 - 2TX CDD Mode

802.11a

Power Output:

Chan.	Freq. (MHz)	Maximum Conducted Power (dBm)		Total Power (mW)	Total Power (dBm)	Power Limit (dBm)	Pass / Fail
		Chain 2	Chain 3				
52	5260	18.24	17.83	127.355	21.05	24.00	Pass
60	5300	18.20	17.92	128.013	21.07	24.00	Pass
64	5320	18.21	18.08	130.491	21.16	24.00	Pass
100	5500	17.97	17.27	115.994	20.64	24.00	Pass
116	5580	18.43	17.82	130.197	21.15	24.00	Pass
140	5700	17.92	17.33	116.019	20.65	24.00	Pass
144	5720 For U-NII-2C	15.08	14.40	59.753	17.76	24.00	Pass
144	5720 For U-NII-3	8.85	8.23	14.327	11.56	30.00	Pass

26dB Bandwidth:

Chan.	Freq. (MHz)	26dBc Bandwidth (MHz)		Pass / Fail
		Chain 2	Chain 3	
52	5260	21.90	21.87	Pass
60	5300	21.93	21.82	Pass
64	5320	21.72	21.85	Pass
100	5500	23.08	21.78	Pass
116	5580	27.72	21.91	Pass
140	5700	32.50	32.61	Pass
144	5720 For U-NII-2C	21.71	21.22	Pass
144	5720 For U-NII-3	12.88	10.15	Pass

Note: For FCC output power limitation is determined based on 26dB bandwidth.

Power Limit = 11 dBm+10 log B <U-NII-2A, U-NII-2C>

Chan.	Freq. (MHz)	Min. B (MHz)	Determined Conducted Limit (dBm)
52	5260	21.87	24.39 > 24
60	5300	21.82	24.38 > 24
64	5320	21.72	24.36 > 24
100	5500	21.78	24.38 > 24
116	5580	21.91	24.40 > 24
140	5700	32.50	26.11 > 24
144	5720 For U-NII-2C	21.22	24.26 > 24

802.11ac (VHT20)

Power Output:

Chan.	Freq. (MHz)	Maximum Conducted Power (dBm)		Total Power (mW)	Total Power (dBm)	Power Limit (dBm)	Pass / Fail
		Chain 2	Chain 3				
52	5260	18.35	18.09	132.808	21.23	24.00	Pass
60	5300	18.37	18.06	132.680	21.23	24.00	Pass
64	5320	18.36	18.10	133.114	21.24	24.00	Pass
100	5500	17.92	17.30	115.647	20.63	24.00	Pass
116	5580	18.38	17.86	129.959	21.14	24.00	Pass
140	5700	18.00	17.44	118.559	20.74	24.00	Pass
144	5720 For U-NII-2C	14.76	14.31	56.900	17.55	24.00	Pass
144	5720 For U-NII-3	9.06	8.57	15.248	11.83	30.00	Pass

26dB Bandwidth:

Chan.	Freq. (MHz)	26dBc Bandwidth (MHz)		Pass / Fail
		Chain 2	Chain 3	
52	5260	26.47	28.22	Pass
60	5300	30.05	26.10	Pass
64	5320	31.10	22.07	Pass
100	5500	34.50	25.95	Pass
116	5580	34.07	31.87	Pass
140	5700	37.22	32.87	Pass
144	5720 For U-NII-2C	24.68	21.60	Pass
144	5720 For U-NII-3	14.51	11.08	Pass

Note: For FCC output power limitation is determined based on 26dB bandwidth.

Power Limit = 11 dBm+10 log B <U-NII-2A, U-NII-2C>

Chan.	Freq. (MHz)	Min. B (MHz)	Determined Conducted Limit (dBm)
52	5260	26.47	25.22 > 24
60	5300	26.10	25.16 > 24
64	5320	22.07	24.43 > 24
100	5500	25.95	25.14 > 24
116	5580	31.87	26.03 > 24
140	5700	32.87	26.16 > 24
144	5720 For U-NII-2C	21.60	24.34 > 24

802.11ac (VHT40)

Power Output:

Chan.	Freq. (MHz)	Maximum Conducted Power (dBm)		Total Power (mW)	Total Power (dBm)	Power Limit (dBm)	Pass / Fail
		Chain 2	Chain 3				
54	5270	20.75	19.39	205.746	23.13	24.00	Pass
62	5310	15.66	14.85	67.362	18.28	24.00	Pass
102	5510	15.71	14.35	64.466	18.09	24.00	Pass
110	5550	21.26	20.10	235.989	23.73	24.00	Pass
134	5670	18.29	16.76	114.877	20.60	24.00	Pass
142	5710 For U-NII-2C	18.38	17.20	121.346	20.84	24.00	Pass
142	5710 For U-NII-3	8.36	6.87	11.719	10.69	30.00	Pass

26dB Bandwidth:

Chan.	Freq. (MHz)	26dBc Bandwidth (MHz)		Pass / Fail
		Chain 2	Chain 3	
54	5270	77.93	73.22	Pass
62	5310	41.11	40.98	Pass
102	5510	41.30	41.00	Pass
110	5550	82.83	74.85	Pass
134	5670	75.10	71.07	Pass
142	5710 For U-NII-2C	63.52	59.85	Pass
142	5710 For U-NII-3	33.83	28.59	Pass

Note: For FCC output power limitation is determined based on 26dB bandwidth.

Power Limit = 11 dBm+10 log B <U-NII-2A, U-NII-2C>			
Chan.	Freq. (MHz)	Min. B (MHz)	Determined Conducted Limit (dBm)
54	5270	73.22	29.64 > 24
62	5310	40.98	27.12 > 24
102	5510	41.00	27.12 > 24
110	5550	74.85	29.74 > 24
134	5670	71.07	29.51 > 24
142	5710 For U-NII-2C	59.85	28.77 > 24

802.11ac (VHT80)

Power Output:

Chan.	Freq. (MHz)	Maximum Conducted Power (dBm)		Total Power (mW)	Total Power (dBm)	Power Limit (dBm)	Pass / Fail
		Chain 2	Chain 3				
58	5290	11.60	10.90	26.757	14.27	24.00	Pass
106	5530	11.90	11.49	29.581	14.71	24.00	Pass
122	5610	18.89	17.71	136.466	21.35	24.00	Pass
138	5690 For U-NII-2C	17.12	16.59	101.139	20.05	24.00	Pass
138	5690 For U-NII-3	3.76	2.91	4.510	6.54	30.00	Pass

26dB Bandwidth:

Chan.	Freq. (MHz)	26dBc Bandwidth (MHz)		Pass / Fail
		Chain 2	Chain 3	
58	5290	126.05	113.36	Pass
106	5530	94.77	103.34	Pass
122	5610	190.41	142.86	Pass
138	5690 For U-NII-2C	132.74	131.30	Pass
138	5690 For U-NII-3	49.13	38.13	Pass

Note: For FCC output poer limitation is determined based on 26dB bandwidth.

Power Limit = 11 dBm+10 log B <U-NII-2A, U-NII-2C>			
Chan.	Freq. (MHz)	Min. B (MHz)	Determined Conducted Limit (dBm)
58	5290	113.36	31.54 > 24
106	5530	94.77	30.76 > 24
122	5610	142.86	32.54 > 24
138	5690 For U-NII-2C	131.30	32.18 > 24

Spectrum Plot of Worst Value

802.11a

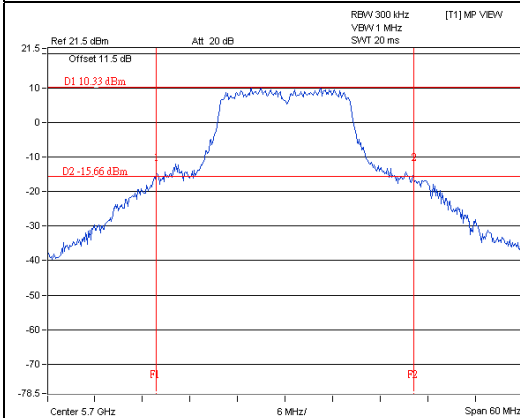

802.11ac (VHT20)

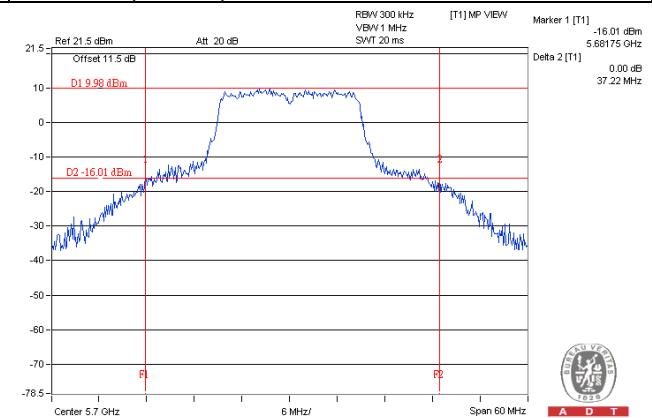

802.11ac (VHT40)

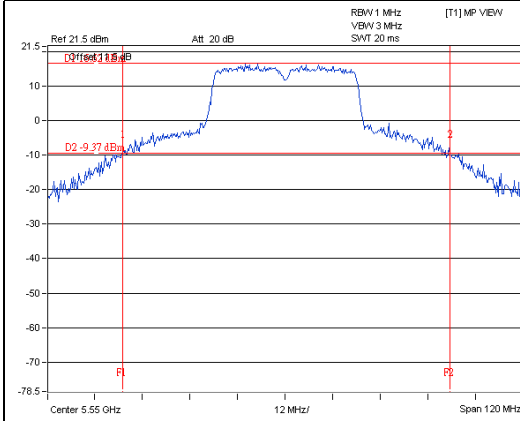

802.11ac (VHT80)

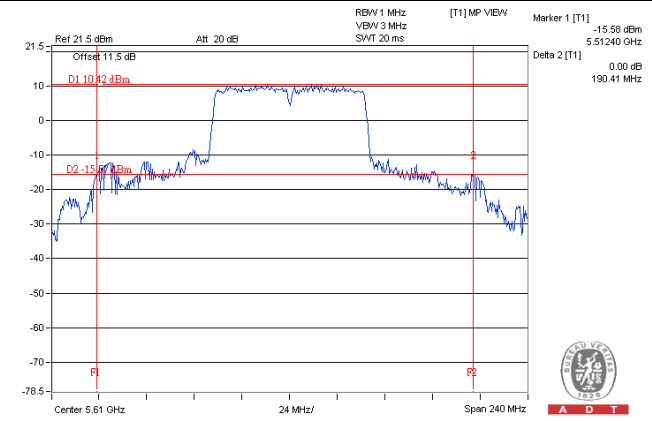

Radio 2 - 2TX TxBF Mode

802.11ac (VHT20)

Power Output:

Chan.	Freq. (MHz)	Maximum Conducted Power (dBm)		Total Power (mW)	Total Power (dBm)	Power Limit (dBm)	Pass / Fail
		Chain 2	Chain 3				
52	5260	18.35	18.09	132.808	21.23	21.25	Pass
60	5300	18.37	18.06	132.680	21.23	21.25	Pass
64	5320	18.36	18.10	133.114	21.24	21.25	Pass
100	5500	17.92	17.30	115.647	20.63	21.28	Pass
116	5580	18.38	17.86	129.959	21.14	21.28	Pass
140	5700	18.00	17.44	118.559	20.74	21.28	Pass
144	5720 For U-NII-2C	14.76	14.31	56.900	17.55	21.28	Pass
144	5720 For U-NII-3	9.06	8.57	15.248	11.83	27.30	Pass

Note:

For U-NII-2A Band: Directional gain = $10 \log[(10^{G1/20} + 10^{G2/20} + \dots + 10^{GN/20})^2/2] = 8.75\text{dBi} > 6\text{dBi}$, so the power limit shall be reduced to "Determined Conducted Limit-(8.75-6)".

For U-NII-2C Band: Directional gain = $10 \log[(10^{G1/20} + 10^{G2/20} + \dots + 10^{GN/20})^2/2] = 8.72\text{dBi} > 6\text{dBi}$, so the power limit shall be reduced to "Determined Conducted Limit-(8.72-6)".

For U-NII-3 Band: Directional gain = $10 \log[(10^{G1/20} + 10^{G2/20} + \dots + 10^{GN/20})^2/2] = 8.70\text{dBi} > 6\text{dBi}$, so the power limit shall be reduced to $30 - (8.70 - 6) = 27.30\text{dBm}$.

26dB Bandwidth:

Chan.	Freq. (MHz)	26dBc Bandwidth (MHz)		Pass / Fail
		Chain 2	Chain 3	
52	5260	26.47	28.22	Pass
60	5300	30.05	26.10	Pass
64	5320	31.10	22.07	Pass
100	5500	34.50	25.95	Pass
116	5580	34.07	31.87	Pass
140	5700	37.22	32.87	Pass
144	5720 For U-NII-2C	24.68	21.60	Pass
144	5720 For U-NII-3	14.51	11.08	Pass

Note: For FCC output power limitation is determined based on 26dB bandwidth.

Power Limit = 11 dBm+10 log B <U-NII-2A, U-NII-2C>

Chan.	Freq. (MHz)	Min. B (MHz)	Determined Conducted Limit (dBm)
52	5260	26.47	25.22 > 24
60	5300	26.10	25.16 > 24
64	5320	22.07	24.43 > 24
100	5500	25.95	25.14 > 24
116	5580	31.87	26.03 > 24
140	5700	32.87	26.16 > 24
144	5720 For U-NII-2C	21.60	24.34 > 24

802.11ac (VHT40)

Power Output:

Chan.	Freq. (MHz)	Maximum Conducted Power (dBm)		Total Power (mW)	Total Power (dBm)	Power Limit (dBm)	Pass / Fail
		Chain 2	Chain 3				
54	5270	18.77	17.42	130.544	21.16	21.25	Pass
62	5310	15.66	14.85	67.362	18.28	21.25	Pass
102	5510	15.71	14.35	64.466	18.09	21.28	Pass
110	5550	18.68	17.44	129.253	21.11	21.28	Pass
134	5670	18.29	16.76	114.877	20.60	21.28	Pass
142	5710 For U-NII-2C	15.69	14.37	64.421	18.09	21.28	Pass
142	5710 For U-NII-3	5.33	3.80	5.811	7.64	27.30	Pass

Note:

For U-NII-2A Band: Directional gain = $10 \log[(10^{G1/20} + 10^{G2/20} + \dots + 10^{GN/20})^2/2]$ = 8.75dBi > 6dBi , so the power limit shall be reduced to "Determined Conducted Limit-(8.75-6)".

For U-NII-2C Band: Directional gain = $10 \log[(10^{G1/20} + 10^{G2/20} + \dots + 10^{GN/20})^2/2]$ = 8.72dBi > 6dBi , so the power limit shall be reduced to "Determined Conducted Limit-(8.72-6)".

For U-NII-3 Band: Directional gain = $10 \log[(10^{G1/20} + 10^{G2/20} + \dots + 10^{GN/20})^2/2]$ = 8.70dBi > 6dBi , so the power limit shall be reduced to 30-(8.70-6) = 27.30dBm.

26dB Bandwidth:

Chan.	Freq. (MHz)	26dBc Bandwidth (MHz)		Pass / Fail
		Chain 2	Chain 3	
54	5270	77.93	73.22	Pass
62	5310	41.11	40.98	Pass
102	5510	41.30	41.00	Pass
110	5550	82.83	74.85	Pass
134	5670	75.10	71.07	Pass
142	5710 For U-NII-2C	63.52	59.85	Pass
142	5710 For U-NII-3	33.83	28.59	Pass

Note: For FCC output power limitation is determined based on 26dB bandwidth.

Power Limit = 11 dBm+10 log B <U-NII-2A, U-NII-2C>

Chan.	Freq. (MHz)	Min. B (MHz)	Determined Conducted Limit (dBm)
54	5270	73.22	29.64 > 24
62	5310	40.98	27.12 > 24
102	5510	41.00	27.12 > 24
110	5550	74.85	29.74 > 24
134	5670	71.07	29.51 > 24
142	5710 For U-NII-2C	59.85	28.77 > 24

802.11ac (VHT80)

Power Output:

Chan.	Freq. (MHz)	Maximum Conducted Power (dBm)		Total Power (mW)	Total Power (dBm)	Power Limit (dBm)	Pass / Fail
		Chain 2	Chain 3				
58	5290	11.60	10.90	26.757	14.27	21.25	Pass
106	5530	11.90	11.49	29.581	14.71	21.28	Pass
122	5610	18.56	17.44	127.242	21.05	21.28	Pass
138	5690 For U-NII-2C	15.40	15.01	69.111	18.40	21.28	Pass
138	5690 For U-NII-3	1.69	1.09	2.875	4.59	27.30	Pass

Note:

For U-NII-2A Band: Directional gain = $10 \log[(10^{G1/20} + 10^{G2/20} + \dots + 10^{GN/20})^2/2] = 8.75\text{dBi} > 6\text{dBi}$, so the power limit shall be reduced to "Determined Conducted Limit-(8.75-6)".

For U-NII-2C Band: Directional gain = $10 \log[(10^{G1/20} + 10^{G2/20} + \dots + 10^{GN/20})^2/2] = 8.72\text{dBi} > 6\text{dBi}$, so the power limit shall be reduced to "Determined Conducted Limit-(8.72-6)".

For U-NII-3 Band: Directional gain = $10 \log[(10^{G1/20} + 10^{G2/20} + \dots + 10^{GN/20})^2/2] = 8.70\text{dBi} > 6\text{dBi}$, so the power limit shall be reduced to $30 - (8.70 - 6) = 27.30\text{dBm}$.

26dB Bandwidth:

Chan.	Freq. (MHz)	26dBc Bandwidth (MHz)		Pass / Fail
		Chain 2	Chain 3	
58	5290	126.05	113.36	Pass
106	5530	94.77	103.34	Pass
122	5610	190.41	142.86	Pass
138	5690 For U-NII-2C	132.74	131.30	Pass
138	5690 For U-NII-3	49.13	38.13	Pass

Note: For FCC output power limitation is determined based on 26dB bandwidth.

Power Limit = 11 dBm+10 log B <U-NII-2A, U-NII-2C>			
Chan.	Freq. (MHz)	Min. B (MHz)	Determined Conducted Limit (dBm)
58	5290	113.36	31.54 > 24
106	5530	94.77	30.76 > 24
122	5610	142.86	32.54 > 24
138	5690 For U-NII-2C	131.30	32.18 > 24

Spectrum Plot of Worst Value

802.11ac (VHT20)

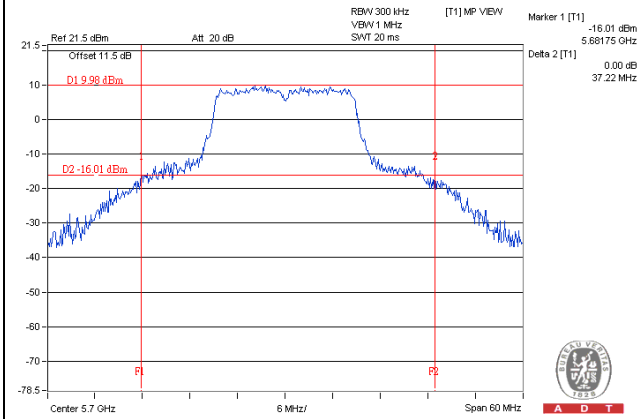

802.11ac (VHT40)

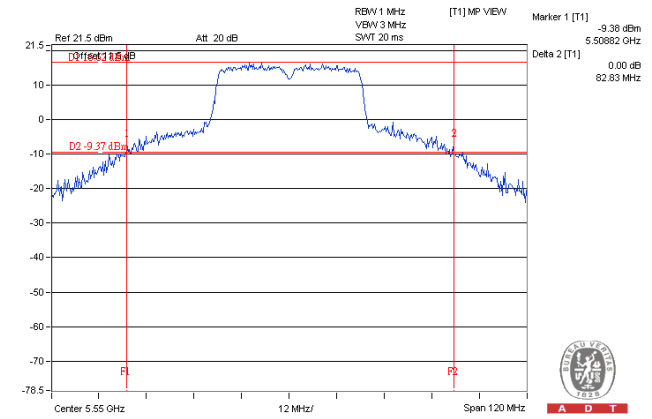

802.11ac (VHT80)

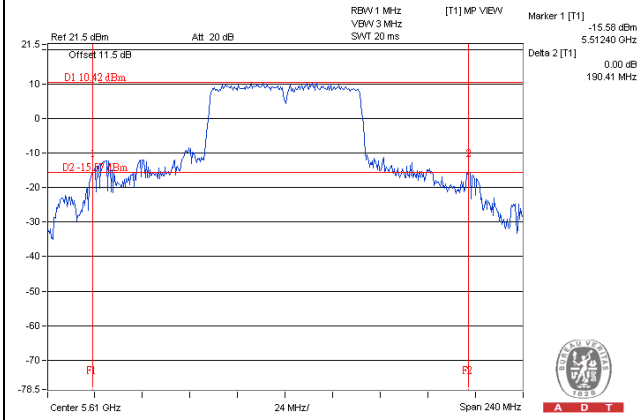

4.4 Occupied Bandwidth Measurement

4.4.1 Test Setup

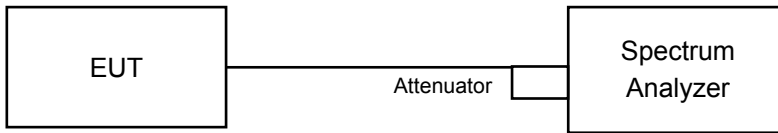

4.4.2 Test Instruments

Refer to section 4.1.2 to get information of above instrument.

4.4.3 Test Procedure

The transmitter output was connected to the spectrum analyzer through an attenuator. The bandwidth of the fundamental frequency was measured by spectrum analyzer with resolution bandwidth in the range of 1% to 5% of the anticipated emission bandwidth, and a video bandwidth at least 3x the resolution bandwidth and set the detector to sample. The width of a frequency band such that, below the lower and above the upper frequency limits, the mean powers emitted are each equal to a specified percentage 0.5 %of the total mean power of a given emission.

4.4.4 Test Result

Radio 1 - 4TX CDD Mode

802.11a

Chan.	Freq. (MHz)	Occupied Bandwidth (MHz)			
		Chain 0	Chain 1	Chain 2	Chain 3
52	5260	16.92	16.92	16.80	16.92
60	5300	17.04	16.92	16.80	16.92
64	5320	16.92	16.80	16.92	16.92
100	5500	17.04	16.80	16.92	16.80
116	5580	17.04	16.92	16.92	16.92
140	5700	16.92	16.92	16.92	16.80
144	5720 For U-NII-2C	13.52	13.52	14.11	13.52
144	5720 For U-NII-3	3.40	3.40	4.01	3.28

802.11ac (VHT20)

Chan.	Freq. (MHz)	Occupied Bandwidth (MHz)			
		Chain 0	Chain 1	Chain 2	Chain 3
52	5260	18.24	17.88	18.00	18.00
60	5300	18.12	17.88	18.12	18.12
64	5320	18.12	18.00	18.00	18.12
100	5500	18.00	18.00	17.88	18.00
116	5580	18.12	18.00	18.00	18.00
140	5700	17.88	18.00	17.88	18.00
144	5720 For U-NII-2C	14.11	14.00	13.52	14.00
144	5720 For U-NII-3	4.01	3.88	3.40	3.88

802.11ac (VHT40)

Chan.	Freq. (MHz)	Occupied Bandwidth (MHz)			
		Chain 0	Chain 1	Chain 2	Chain 3
54	5270	36.96	36.96	36.72	36.72
62	5310	36.72	36.72	36.72	36.72
102	5510	36.72	36.96	36.72	36.96
110	5550	36.72	36.72	36.72	36.72
134	5670	36.96	36.96	36.72	36.72
142	5710 For U-NII-2C	33.60	33.39	33.60	33.60
142	5710 For U-NII-3	3.20	3.21	3.20	3.40

802.11ac (VHT80)

Chan.	Freq. (MHz)	Occupied Bandwidth (MHz)			
		Chain 0	Chain 1	Chain 2	Chain 3
58	5290	76.32	75.84	76.32	75.84
106	5530	75.36	76.32	75.84	75.84
122	5610	76.32	76.32	76.32	76.32
138	5690 For U-NII-2C	73.39	73.39	73.39	73.39
138	5690 For U-NII-3	3.41	2.92	2.92	2.92

Spectrum Plot of Worst Value

802.11a

802.11ac (VHT20)

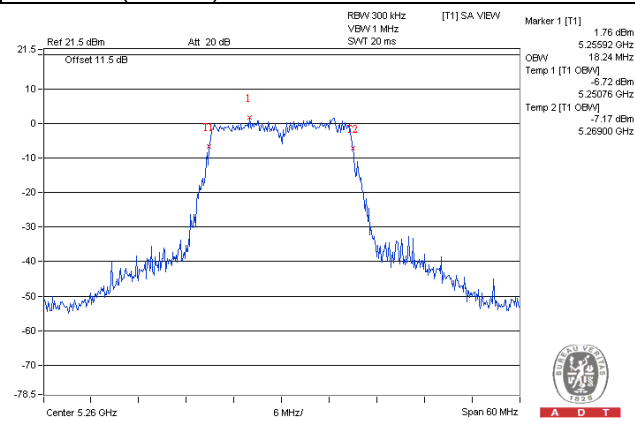
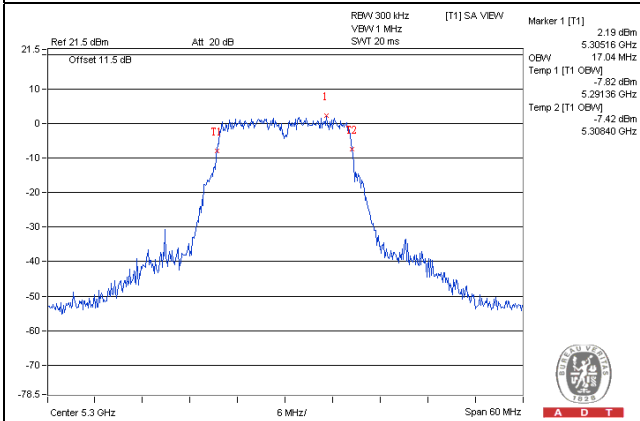

802.11ac (VHT40)

802.11ac (VHT80)

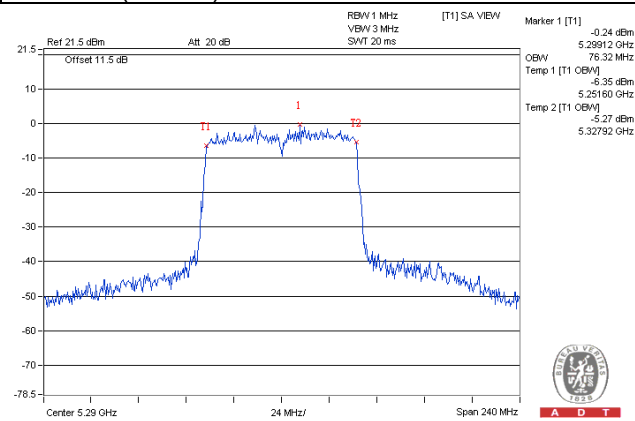
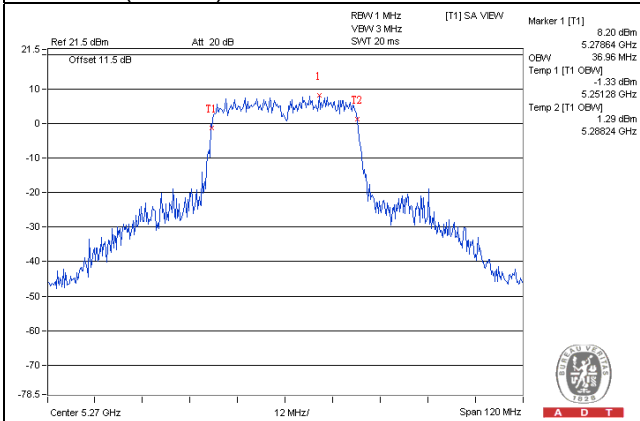

Radio 1 - 2TX CDD Mode

802.11a

Chan.	Freq. (MHz)	Occupied Bandwidth (MHz)	
		Chain 0	Chain 3
52	5260	17.40	17.52
60	5300	17.76	17.40
64	5320	17.52	17.40

Chan.	Freq. (MHz)	Occupied Bandwidth (MHz)	
		Chain 1	Chain 3
100	5500	17.40	17.52
116	5580	17.16	17.64
140	5700	17.40	17.52
144	5720 For U-NII-2C	14.00	14.23
144	5720 For U-NII-3	3.76	3.77

802.11ac (VHT20)

Chan.	Freq. (MHz)	Occupied Bandwidth (MHz)	
		Chain 0	Chain 3
52	5260	18.36	18.24
60	5300	18.48	18.48
64	5320	18.36	18.36

Chan.	Freq. (MHz)	Occupied Bandwidth (MHz)	
		Chain 1	Chain 3
100	5500	18.36	18.60
116	5580	18.48	18.72
140	5700	18.12	18.24
144	5720 For U-NII-2C	14.47	14.47
144	5720 For U-NII-3	4.37	4.13

802.11ac (VHT40)

Chan.	Freq. (MHz)	Occupied Bandwidth (MHz)	
		Chain 0	Chain 3
54	5270	52.32	47.04
62	5310	36.72	36.72

Chan.	Freq. (MHz)	Occupied Bandwidth (MHz)	
		Chain 1	Chain 3
102	5510	36.72	36.72
110	5550	48.48	49.44
134	5670	37.68	37.44
142	5710 For U-NII-2C	44.00	46.00
142	5710 For U-NII-3	14.40	15.00

802.11ac (VHT80)

Chan.	Freq. (MHz)	Occupied Bandwidth (MHz)	
		Chain 0	Chain 3
58	5290	75.84	76.32

Chan.	Freq. (MHz)	Occupied Bandwidth (MHz)	
		Chain 1	Chain 3
106	5530	75.36	76.32
122	5610	76.32	76.80
138	5690 For U-NII-2C	74.35	73.39
138	5690 For U-NII-3	8.21	3.41

Spectrum Plot of Worst Value

802.11a

802.11ac (VHT20)

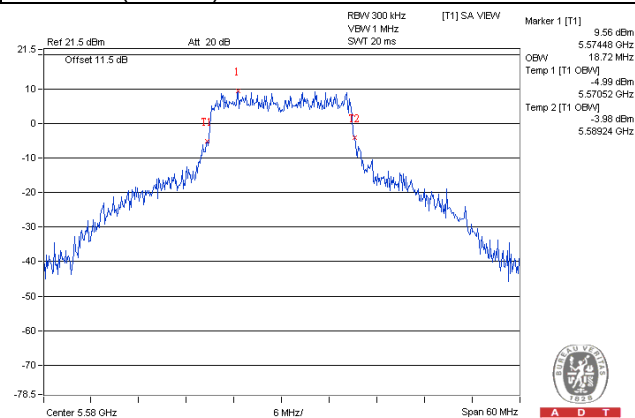
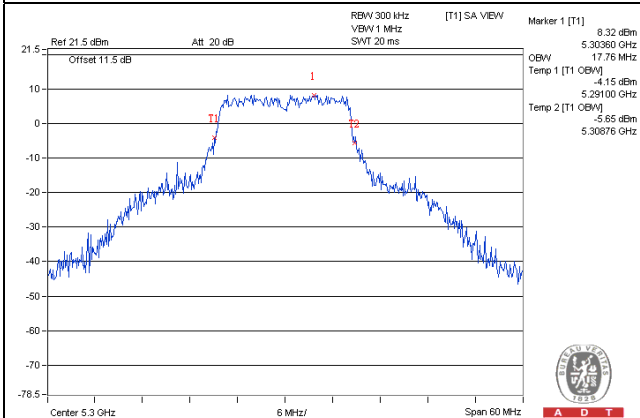

802.11ac (VHT40)

802.11ac (VHT80)

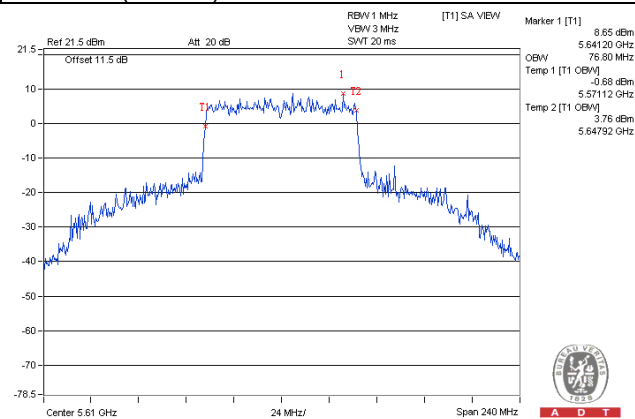
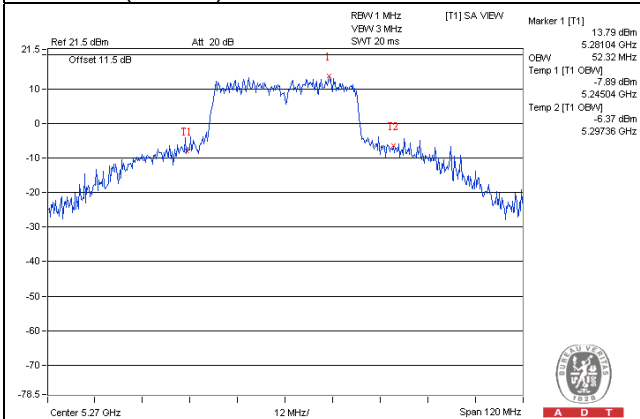

Radio 2 - 4TX CDD Mode

802.11a

Chan.	Freq. (MHz)	Occupied Bandwidth (MHz)			
		Chain 0	Chain 1	Chain 2	Chain 3
52	5260	16.92	16.92	16.80	16.80
60	5300	17.16	16.80	17.04	16.92
64	5320	17.04	16.92	16.92	16.68
100	5500	17.04	17.04	16.80	16.80
116	5580	16.92	16.92	16.92	16.80
140	5700	16.92	16.92	16.92	16.92
144	5720 For U-NII-2C	13.52	13.52	13.52	13.52
144	5720 For U-NII-3	3.28	3.40	3.28	3.40

802.11ac (VHT20)

Chan.	Freq. (MHz)	Occupied Bandwidth (MHz)			
		Chain 0	Chain 1	Chain 2	Chain 3
52	5260	18.12	18.00	18.00	18.00
60	5300	18.12	18.00	18.12	18.00
64	5320	18.00	18.00	18.00	17.88
100	5500	18.00	18.00	18.00	18.00
116	5580	18.00	18.12	18.12	18.00
140	5700	18.00	18.00	17.88	18.12
144	5720 For U-NII-2C	14.11	14.11	14.11	14.11
144	5720 For U-NII-3	3.89	3.89	3.89	4.01

802.11ac (VHT40)

Chan.	Freq. (MHz)	Occupied Bandwidth (MHz)			
		Chain 0	Chain 1	Chain 2	Chain 3
54	5270	36.72	36.72	36.72	36.48
62	5310	36.72	36.96	36.72	36.72
102	5510	36.96	36.72	36.72	36.72
110	5550	36.72	36.72	36.72	36.72
134	5670	36.72	36.72	37.20	36.96
142	5710 For U-NII-2C	33.60	33.39	33.39	33.60
142	5710 For U-NII-3	3.20	3.21	3.21	3.20

802.11ac (VHT80)

Chan.	Freq. (MHz)	Occupied Bandwidth (MHz)			
		Chain 0	Chain 1	Chain 2	Chain 3
58	5290	76.32	76.32	76.32	76.32
106	5530	76.32	76.32	76.32	75.84
122	5610	76.32	76.32	100.80	76.32
138	5690 For U-NII-2C	73.39	73.39	73.39	73.39
138	5690 For U-NII-3	2.92	2.92	2.92	2.92

Spectrum Plot of Worst Value

802.11a

802.11ac (VHT20)

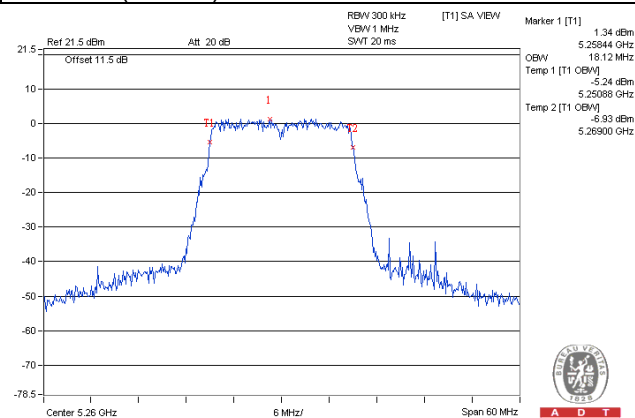
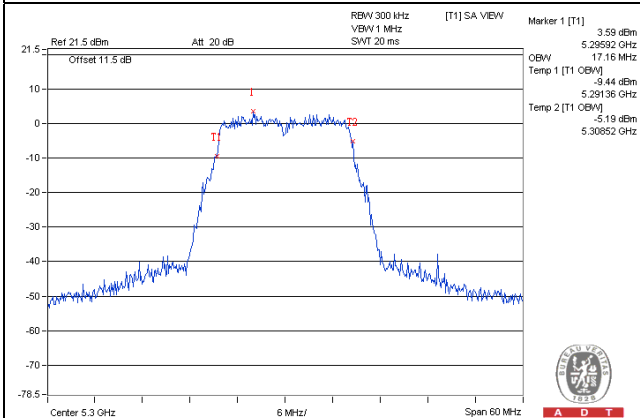

802.11ac (VHT40)

802.11ac (VHT80)

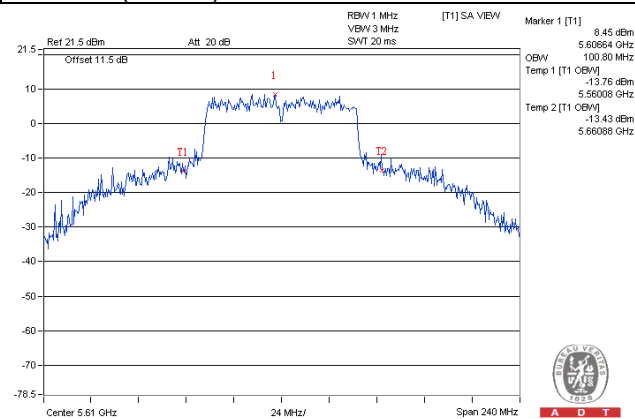
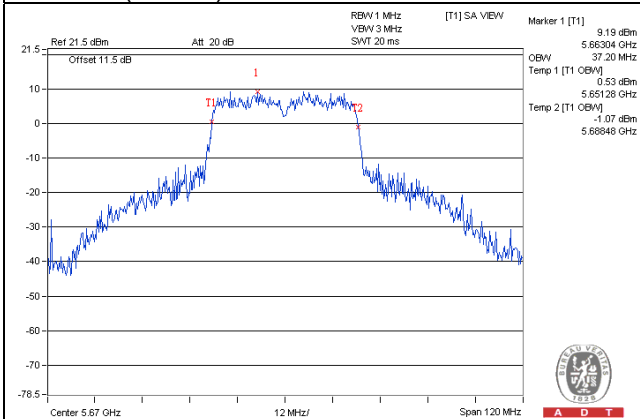

Radio 2 - 2TX CDD Mode

802.11a

Chan.	Freq. (MHz)	Occupied Bandwidth (MHz)	
		Chain 2	Chain 3
52	5260	17.04	16.92
60	5300	17.04	16.92
64	5320	16.92	16.92
100	5500	17.16	16.92
116	5580	17.16	16.92
140	5700	17.28	17.52
144	5720 For U-NII-2C	13.88	13.64
144	5720 For U-NII-3	3.76	3.52

802.11ac (VHT20)

Chan.	Freq. (MHz)	Occupied Bandwidth (MHz)	
		Chain 2	Chain 3
52	5260	18.00	18.00
60	5300	18.12	18.00
64	5320	18.12	18.12
100	5500	18.12	18.12
116	5580	18.24	18.12
140	5700	18.48	18.24
144	5720 For U-NII-2C	14.23	14.23
144	5720 For U-NII-3	4.25	4.13

802.11ac (VHT40)

Chan.	Freq. (MHz)	Occupied Bandwidth (MHz)	
		Chain 2	Chain 3
54	5270	37.20	36.96
62	5310	36.72	36.72
102	5510	36.72	36.48
110	5550	39.60	36.96
134	5670	37.20	36.96
142	5710 For U-NII-2C	43.19	35.00
142	5710 For U-NII-3	13.41	4.40

802.11ac (VHT80)

Chan.	Freq. (MHz)	Occupied Bandwidth (MHz)	
		Chain 2	Chain 3
58	5290	75.84	76.32
106	5530	76.32	76.32
122	5610	76.32	76.32
138	5690 For U-NII-2C	74.84	73.39
138	5690 For U-NII-3	3.39	3.41

Spectrum Plot of Worst Value

802.11a

802.11ac (VHT20)

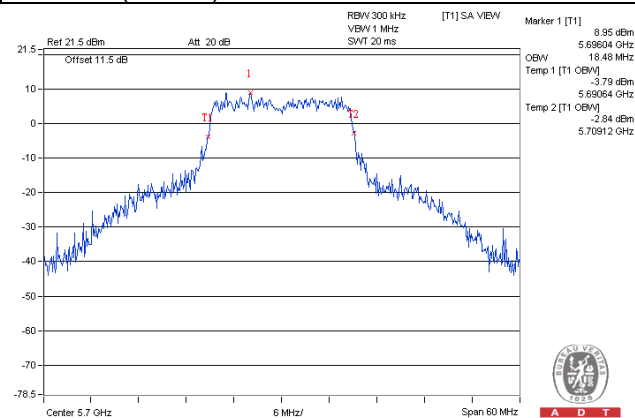
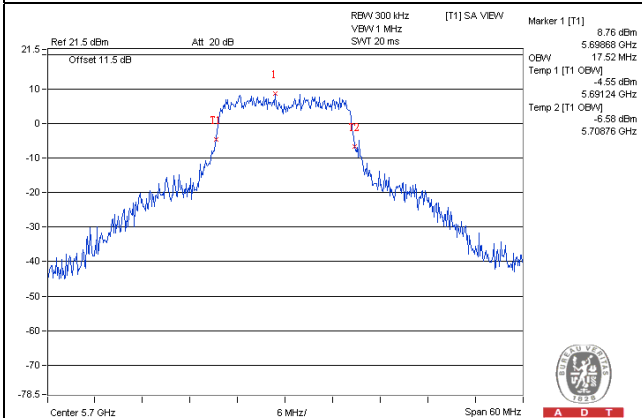

802.11ac (VHT40)

802.11ac (VHT80)

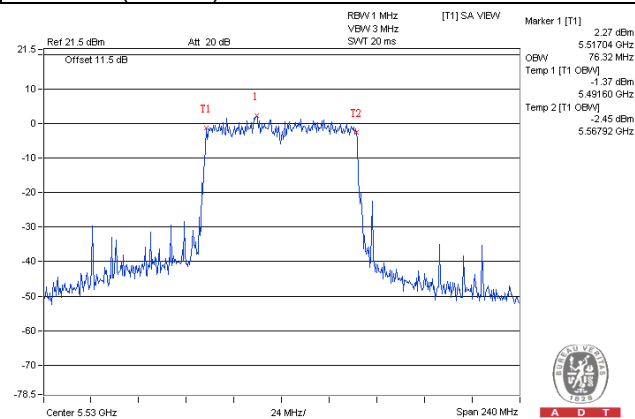
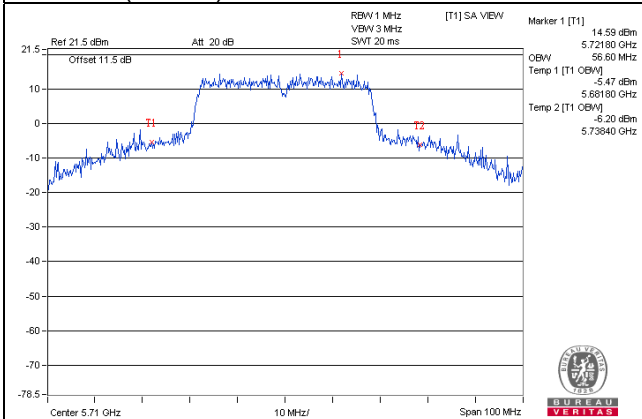

4.5 Peak Power Spectral Density Measurement

4.5.1 Limits of Peak Power Spectral Density Measurement

Operation Band	EUT Category		LIMIT
U-NII-1	---	Outdoor Access Point	17dBm/ MHz
	---	Fixed point-to-point Access Point	
	---	Indoor Access Point	
	---	Mobile and Portable client device	11dBm/ MHz
U-NII-2A	√		11dBm/ MHz
U-NII-2C	√		11dBm/ MHz
U-NII-3	√		30dBm/ 500kHz

4.5.2 Test Setup

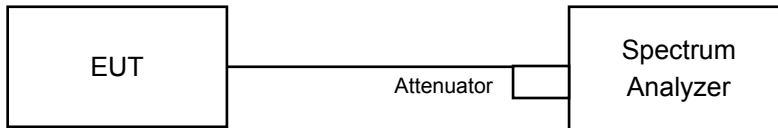

4.5.3 Test Instruments

Refer to section 4.1.2 to get information of above instrument.

4.5.4 Test Procedures

For U-NII-2A and U-NII-2C Band:

Using method SA-1, Duty cycle >98%:

- a. Set span to encompass the entire emission bandwidth (EBW) of the signal.
- b. Set RBW = 1 MHz, Set VBW \geq 3 MHz, Detector = RMS
- c. Sweep time = auto, trigger set to "free run".
- d. Trace average at least 100 traces in power averaging mode.
- e. Record the max value

Using method SA-2, Duty cycle <98%

- a. Set span to encompass the entire emission bandwidth (EBW) of the signal.
- b. Set RBW = 1 MHz, Set VBW \geq 3 MHz, Detector = RMS
- c. Sweep time = auto, trigger set to "free run".
- d. Trace average at least 100 traces in power averaging mode.
- e. Record the max value and add $10 \log (1/\text{duty cycle})$

For U-NII-3 Band:

Duty cycle >98%

- a. Set span to encompass the entire emission bandwidth (EBW) of the signal.
- b. Set RBW = 300 kHz, Set VBW \geq 1 MHz, Detector = RMS
- c. Use the peak marker function to determine the maximum power level in any 300 kHz band segment within the fundamental EBW.
- d. Scale the observed power level to an equivalent value in 500 kHz by adjusting (reducing) the measured power by a bandwidth correction factor (BWCF) where $\text{BWCF} = 10\log(500 \text{ kHz}/300\text{kHz})$
- e. Sweep time = auto, trigger set to "free run".
- f. Trace average at least 100 traces in power averaging mode.
- g. Record the max value

Duty cycle <98%

- a. Set span to encompass the entire emission bandwidth (EBW) of the signal.
- b. Set RBW = 300 kHz, Set VBW \geq 1 MHz, Detector = RMS
- c. Use the peak marker function to determine the maximum power level in any 300 kHz band segment within the fundamental EBW.
- d. Scale the observed power level to an equivalent value in 500 kHz by adjusting (reducing) the measured power by a bandwidth correction factor (BWCF) where $\text{BWCF} = 10\log(500 \text{ kHz}/300\text{kHz})$
- e. Sweep time = auto, trigger set to "free run".
- f. Trace average at least 100 traces in power averaging mode.
- g. Record the max value and add $10 \log (1/\text{duty cycle})$

4.5.5 Deviation from Test Standard

No deviation.

4.5.6 EUT Operating Conditions

Same as Item 4.3.6.

4.5.7 Test Results

For U-NII-2A and U-NII-2C Band:

Radio 1 - 4TX CDD Mode

802.11a

Chan.	Freq. (MHz)	PSD (dBm)				Total PSD (dBm)	Max. Limit (dBm)	Pass / Fail
		Chain 0	Chain 1	Chain 2	Chain 3			
52	5260	-0.35	-1.05	-1.85	-1.55	4.86	5.31	Pass
60	5300	0.06	-0.83	-1.32	-1.01	5.28	5.31	Pass
64	5320	-0.39	-1.22	-1.74	-1.33	4.88	5.31	Pass
100	5500	-0.68	-0.95	-0.97	-0.42	5.27	5.45	Pass
116	5580	-1.02	-1.31	-1.39	-0.94	4.86	5.45	Pass
140	5700	-0.84	-0.92	-1.64	-1.44	4.82	5.45	Pass
144	5720	-0.42	-0.92	-1.01	-0.64	5.28	5.45	Pass

Note:

- Method 1 of power density measurement of KDB 662911 is using for calculating total power density. Total power density is summing entire spectra across corresponding frequency bins on the various outputs by computer.
- U-NII-2A Band: Directional gain = $10 \log[(10^{G1/20} + 10^{G2/20} + \dots + 10^{GN/20})^2/4] = 11.69\text{dBi} > 6\text{dBi}$, so the power density limit shall be reduced to $11 - (11.69 - 6) = 5.31\text{dBm}$.
- U-NII-2C Band: Directional gain = $10 \log[(10^{G1/20} + 10^{G2/20} + \dots + 10^{GN/20})^2/4] = 11.55\text{dBi} > 6\text{dBi}$, so the power density limit shall be reduced to $11 - (11.55 - 6) = 5.45\text{dBm}$.

802.11ac (VHT20)

Chan.	Freq. (MHz)	PSD (dBm)				Total PSD (dBm)	Max. Limit (dBm)	Pass / Fail
		Chain 0	Chain 1	Chain 2	Chain 3			
52	5260	-0.28	-1.11	-1.50	-1.61	4.93	5.31	Pass
60	5300	0.06	-0.89	-1.20	-1.27	5.23	5.31	Pass
64	5320	-0.49	-1.35	-1.18	-1.47	4.92	5.31	Pass
100	5500	-0.54	-0.85	-1.61	-0.80	5.09	5.45	Pass
116	5580	-0.96	-1.29	-1.29	-1.12	4.86	5.45	Pass
140	5700	-1.02	-1.18	-1.39	-1.52	4.75	5.45	Pass
144	5720	-0.52	-1.28	-1.03	-1.20	5.02	5.45	Pass

Note:

- Method 1 of power density measurement of KDB 662911 is using for calculating total power density. Total power density is summing entire spectra across corresponding frequency bins on the various outputs by computer.
- U-NII-2A Band: Directional gain = $10 \log[(10^{G1/20} + 10^{G2/20} + \dots + 10^{GN/20})^2/4] = 11.69\text{dBi} > 6\text{dBi}$, so the power density limit shall be reduced to $11 - (11.69 - 6) = 5.31\text{dBm}$.
- U-NII-2C Band: Directional gain = $10 \log[(10^{G1/20} + 10^{G2/20} + \dots + 10^{GN/20})^2/4] = 11.55\text{dBi} > 6\text{dBi}$, so the power density limit shall be reduced to $11 - (11.55 - 6) = 5.45\text{dBm}$.

802.11ac (VHT40)

Chan.	Freq. (MHz)	PSD (dBm)				Total PSD (dBm)	Max. Limit (dBm)	Pass / Fail
		Chain 0	Chain 1	Chain 2	Chain 3			
54	5270	-0.71	-0.54	-1.40	-1.34	5.04	5.31	Pass
62	5310	-5.31	-5.45	-5.87	-5.62	0.46	5.31	Pass
102	5510	-4.11	-4.43	-3.98	-3.88	1.93	5.45	Pass
110	5550	-1.80	-2.27	-1.85	-1.82	4.09	5.45	Pass
134	5670	-2.61	-2.95	-2.93	-2.58	3.26	5.45	Pass
142	5710	-1.10	-1.40	-0.86	-0.52	5.06	5.45	Pass

Note:

- Method 1 of power density measurement of KDB 662911 is using for calculating total power density. Total power density is summing entire spectra across corresponding frequency bins on the various outputs by computer.
- U-NII-2A Band: Directional gain = $10 \log[(10^{G1/20} + 10^{G2/20} + \dots + 10^{GN/20})^2/4] = 11.69\text{dBi} > 6\text{dBi}$, so the power density limit shall be reduced to $11 - (11.69 - 6) = 5.31\text{dBm}$.
- U-NII-2C Band: Directional gain = $10 \log[(10^{G1/20} + 10^{G2/20} + \dots + 10^{GN/20})^2/4] = 11.55\text{dBi} > 6\text{dBi}$, so the power density limit shall be reduced to $11 - (11.55 - 6) = 5.45\text{dBm}$.

802.11ac (VHT80)

Chan.	Freq. (MHz)	PSD (dBm)				Total PSD w/o duty factor (dBm)	Duty factor	Total PSD with duty factor (dBm)	Max. Limit (dBm)	Pass / Fail
		Chain 0	Chain 1	Chain 2	Chain 3					
58	5290	-10.58	-11.21	-10.97	-10.64	-4.83	0.18	-4.65	5.31	Pass
106	5530	-9.77	-10.60	-9.56	-9.87	-3.92	0.18	-3.74	5.45	Pass
122	5610	-3.39	-3.84	-3.35	-3.34	2.54	0.18	2.72	5.45	Pass
138	5690	-2.09	-2.77	-3.27	-2.87	3.29	0.18	3.47	5.45	Pass

Note:

- Method 1 of power density measurement of KDB 662911 is using for calculating total power density. Total power density is summing entire spectra across corresponding frequency bins on the various outputs by computer.
- U-NII-2A Band: Directional gain = $10 \log[(10^{G1/20} + 10^{G2/20} + \dots + 10^{GN/20})^2/4] = 11.69\text{dBi} > 6\text{dBi}$, so the power density limit shall be reduced to $11 - (11.69 - 6) = 5.31\text{dBm}$.
- U-NII-2C Band: Directional gain = $10 \log[(10^{G1/20} + 10^{G2/20} + \dots + 10^{GN/20})^2/4] = 11.55\text{dBi} > 6\text{dBi}$, so the power density limit shall be reduced to $11 - (11.55 - 6) = 5.45\text{dBm}$.
- Refer to section 3.3 for duty cycle spectrum plot.

Spectrum Plot of Worst Value

802.11a / Chain 0 / CH 60

802.11ac (VHT20) / Chain 0 / CH 60

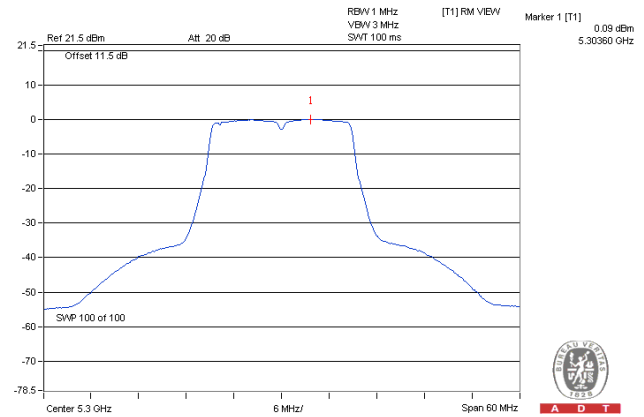
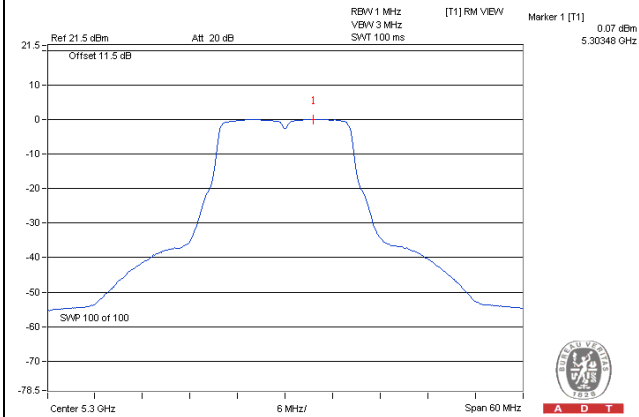

802.11ac (VHT40) / Chain 3 / CH 142

802.11ac (VHT80) / Chain 0 / CH 138

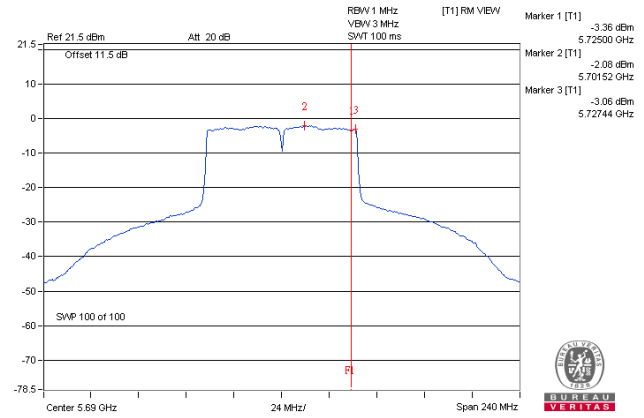
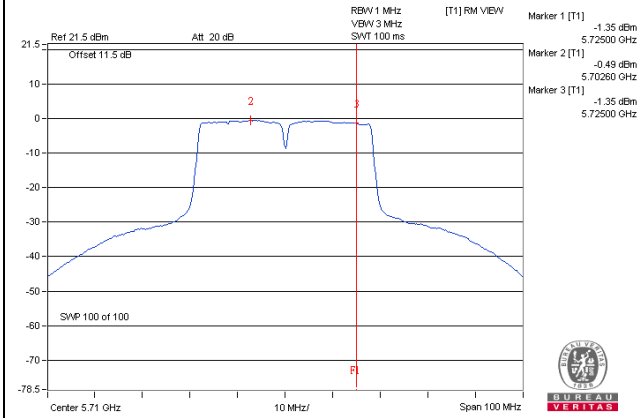

Radio 1 - 2TX CDD Mode

802.11a

Chan.	Freq. (MHz)	PSD (dBm)		Total PSD (dBm)	Max. Limit (dBm)	Pass / Fail
		Chain 0	Chain 3			
52	5260	5.09	4.19	7.67	8.07	Pass
60	5300	4.66	4.63	7.66	8.07	Pass
64	5320	4.90	4.09	7.52	8.07	Pass

Chan.	Freq. (MHz)	PSD (dBm)		Total PSD (dBm)	Max. Limit (dBm)	Pass / Fail
		Chain 1	Chain 3			
100	5500	4.99	4.95	7.98	8.23	Pass
116	5580	4.71	4.63	7.68	8.23	Pass
140	5700	5.15	4.12	7.68	8.23	Pass
144	5720	4.98	4.19	7.61	8.23	Pass

Note:

1. Method 1 of power density measurement of KDB 662911 is using for calculating total power density. Total power density is summing entire spectra across corresponding frequency bins on the various outputs by computer.
2. U-NII-2A Band: Directional gain = $10 \log[(10^{G1/20} + 10^{G2/20} + \dots + 10^{GN/20})^2/2] = 8.93\text{dBi} > 6\text{dBi}$, so the power density limit shall be reduced to $11 - (8.93 - 6) = 8.07\text{dBm}$.
3. U-NII-2C Band: Directional gain = $10 \log[(10^{G1/20} + 10^{G2/20} + \dots + 10^{GN/20})^2/2] = 8.77\text{dBi} > 6\text{dBi}$, so the power density limit shall be reduced to $11 - (8.77 - 6) = 8.23\text{dBm}$.

802.11ac (VHT20)

Chan.	Freq. (MHz)	PSD (dBm)		Total PSD (dBm)	Max. Limit (dBm)	Pass / Fail
		Chain 0	Chain 3			
52	5260	4.94	4.18	7.59	8.07	Pass
60	5300	5.11	4.67	7.91	8.07	Pass
64	5320	5.26	4.71	8.00	8.07	Pass

Chan.	Freq. (MHz)	PSD (dBm)		Total PSD (dBm)	Max. Limit (dBm)	Pass / Fail
		Chain 1	Chain 3			
100	5500	4.51	4.89	7.71	8.23	Pass
116	5580	4.15	5.00	7.61	8.23	Pass
140	5700	2.97	2.61	5.80	8.23	Pass
144	5720	4.57	4.82	7.71	8.23	Pass

Note:

- Method 1 of power density measurement of KDB 662911 is using for calculating total power density. Total power density is summing entire spectra across corresponding frequency bins on the various outputs by computer.
- U-NII-2A Band: Directional gain = $10 \log[(10^{G1/20} + 10^{G2/20} + \dots + 10^{GN/20})^2/2] = 8.93\text{dBi} > 6\text{dBi}$, so the power density limit shall be reduced to $11-(8.93-6) = 8.07\text{dBm}$.
- U-NII-2C Band: Directional gain = $10 \log[(10^{G1/20} + 10^{G2/20} + \dots + 10^{GN/20})^2/2] = 8.77\text{dBi} > 6\text{dBi}$, so the power density limit shall be reduced to $11-(8.77-6) = 8.23\text{dBm}$.

802.11ac (VHT40)

Chan.	Freq. (MHz)	PSD (dBm)		Total PSD (dBm)	Max. Limit (dBm)	Pass / Fail
		Chain 0	Chain 3			
54	5270	3.59	2.60	6.13	8.07	Pass
62	5310	-3.33	-4.36	-0.80	8.07	Pass

Chan.	Freq. (MHz)	PSD (dBm)		Total PSD (dBm)	Max. Limit (dBm)	Pass / Fail
		Chain 1	Chain 3			
102	5510	-2.15	-2.30	0.79	8.23	Pass
110	5550	3.63	3.58	6.62	8.23	Pass
134	5670	1.11	0.92	4.03	8.23	Pass
142	5710	3.94	3.54	6.75	8.23	Pass

Note:

- Method 1 of power density measurement of KDB 662911 is using for calculating total power density. Total power density is summing entire spectra across corresponding frequency bins on the various outputs by computer.
- U-NII-2A Band: Directional gain = $10 \log[(10^{G1/20} + 10^{G2/20} + \dots + 10^{GN/20})^2/2] = 8.93\text{dBi} > 6\text{dBi}$, so the power density limit shall be reduced to $11-(8.93-6) = 8.07\text{dBm}$.
- U-NII-2C Band: Directional gain = $10 \log[(10^{G1/20} + 10^{G2/20} + \dots + 10^{GN/20})^2/2] = 8.77\text{dBi} > 6\text{dBi}$, so the power density limit shall be reduced to $11-(8.77-6) = 8.23\text{dBm}$.

802.11ac (VHT80)

Chan.	Freq. (MHz)	PSD (dBm)		Total PSD w/o duty factor (dBm)	Duty factor	Total PSD with duty factor (dBm)	Max. Limit (dBm)	Pass / Fail
		Chain 0	Chain 3					
58	5290	-7.93	-8.49	-5.19	0.18	-5.01	8.07	Pass

Chan.	Freq. (MHz)	PSD (dBm)		Total PSD w/o duty factor (dBm)	Duty factor	Total PSD with duty factor (dBm)	Max. Limit (dBm)	Pass / Fail
		Chain 1	Chain 3					
106	5530	-7.37	-7.48	-4.42	0.18	-4.24	8.23	Pass
122	5610	-1.73	-1.82	1.23	0.18	1.41	8.23	Pass
138	5690	-0.56	-1.48	2.01	0.18	2.19	8.23	Pass

Note:

- Method 1 of power density measurement of KDB 662911 is using for calculating total power density. Total power density is summing entire spectra across corresponding frequency bins on the various outputs by computer.
- U-NII-2A Band: Directional gain = $10 \log[(10^{G1/20} + 10^{G2/20} + \dots + 10^{GN/20})^2/2] = 8.93\text{dBi} > 6\text{dBi}$, so the power density limit shall be reduced to $11 - (8.93 - 6) = 8.07\text{dBm}$.
- U-NII-2C Band: Directional gain = $10 \log[(10^{G1/20} + 10^{G2/20} + \dots + 10^{GN/20})^2/2] = 8.77\text{dBi} > 6\text{dBi}$, so the power density limit shall be reduced to $11 - (8.77 - 6) = 8.23\text{dBm}$.
- Refer to section 3.3 for duty cycle spectrum plot.

Spectrum Plot of Worst Value

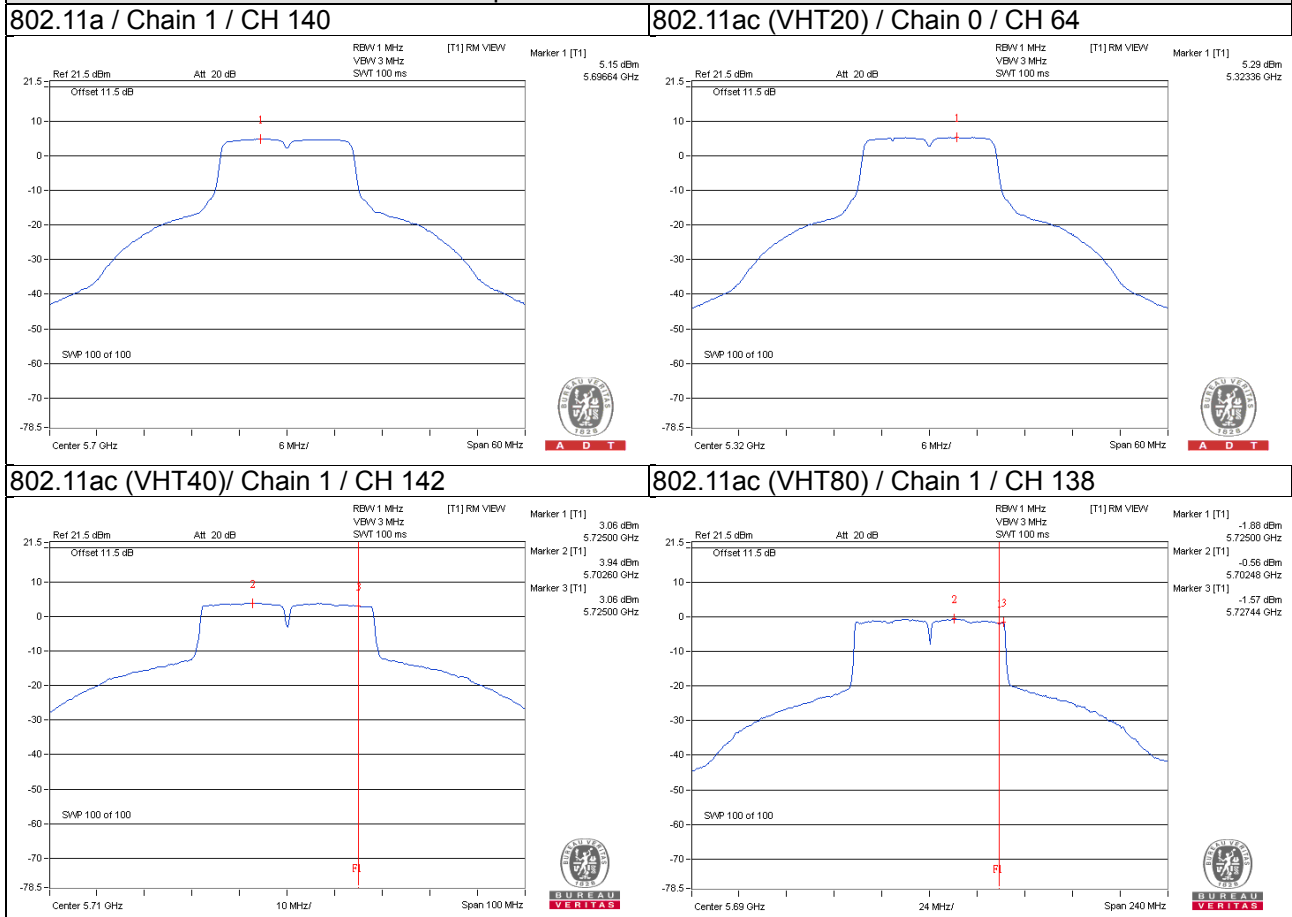

Radio 2 - 4TX with CDD Mode

802.11a

Chan.	Freq. (MHz)	PSD (dBm)				Total PSD (dBm)	Max. Limit (dBm)	Pass / Fail
		Chain 0	Chain 1	Chain 2	Chain 3			
52	5260	-0.92	-0.95	-1.18	-1.38	4.92	5.42	Pass
60	5300	-0.95	-0.98	-1.04	-1.82	4.84	5.42	Pass
64	5320	-0.95	-0.92	-1.06	-1.88	4.84	5.42	Pass
100	5500	-0.87	-1.58	-1.08	-1.39	4.80	5.38	Pass
116	5580	-1.00	-1.36	-0.98	-1.57	4.80	5.38	Pass
140	5700	-1.10	-1.16	-0.82	-1.35	4.92	5.38	Pass
144	5720	-0.60	-1.16	-1.59	-1.54	4.82	5.38	Pass

Note:

- Method 1 of power density measurement of KDB 662911 is using for calculating total power density. Total power density is summing entire spectra across corresponding frequency bins on the various outputs by computer.
- U-NII-2A Band: Directional gain = $10 \log[(10^{G1/20} + 10^{G2/20} + \dots + 10^{GN/20})^2/4] = 11.58\text{dBi} > 6\text{dBi}$, so the power density limit shall be reduced to $11-(11.58-6) = 5.42\text{dBm}$.
- U-NII-2C Band: Directional gain = $10 \log[(10^{G1/20} + 10^{G2/20} + \dots + 10^{GN/20})^2/4] = 11.62\text{dBi} > 6\text{dBi}$, so the power density limit shall be reduced to $11-(11.62-6) = 5.38\text{dBm}$.

802.11ac (VHT20)

Chan.	Freq. (MHz)	PSD (dBm)				Total PSD (dBm)	Max. Limit (dBm)	Pass / Fail
		Chain 0	Chain 1	Chain 2	Chain 3			
52	5260	-0.97	-0.84	-1.66	-1.53	4.78	5.42	Pass
60	5300	-0.81	-0.84	-0.99	-1.51	4.99	5.42	Pass
64	5320	-0.91	-0.77	-1.03	-1.41	5.00	5.42	Pass
100	5500	-0.60	-1.21	-0.59	-1.07	5.16	5.38	Pass
116	5580	-0.90	-1.05	-0.89	-1.52	4.94	5.38	Pass
140	5700	-0.86	-0.85	-1.05	-1.22	5.03	5.38	Pass
144	5720	-0.53	-1.49	-1.73	-1.81	4.66	5.38	Pass

Note:

- Method 1 of power density measurement of KDB 662911 is using for calculating total power density. Total power density is summing entire spectra across corresponding frequency bins on the various outputs by computer.
- U-NII-2A Band: Directional gain = $10 \log[(10^{G1/20} + 10^{G2/20} + \dots + 10^{GN/20})^2/4] = 11.58\text{dBi} > 6\text{dBi}$, so the power density limit shall be reduced to $11-(11.58-6) = 5.42\text{dBm}$.
- U-NII-2C Band: Directional gain = $10 \log[(10^{G1/20} + 10^{G2/20} + \dots + 10^{GN/20})^2/4] = 11.62\text{dBi} > 6\text{dBi}$, so the power density limit shall be reduced to $11-(11.62-6) = 5.38\text{dBm}$.

802.11ac (VHT40)

Chan.	Freq. (MHz)	PSD (dBm)				Total PSD (dBm)	Max. Limit (dBm)	Pass / Fail
		Chain 0	Chain 1	Chain 2	Chain 3			
54	5270	-0.62	-1.05	-0.81	-2.51	4.83	5.42	Pass
62	5310	-1.41	-1.75	-1.74	-2.95	4.10	5.42	Pass
102	5510	-2.91	-3.74	-3.45	-4.97	2.32	5.38	Pass
110	5550	-0.61	-1.72	-1.06	-2.12	4.68	5.38	Pass
134	5670	-0.83	-1.54	-0.73	-1.95	4.79	5.38	Pass
142	5710	-0.93	-1.71	-1.13	-2.17	4.56	5.38	Pass

Note:

- Method 1 of power density measurement of KDB 662911 is using for calculating total power density. Total power density is summing entire spectra across corresponding frequency bins on the various outputs by computer.
- U-NII-2A Band: Directional gain = $10 \log[(10^{G1/20} + 10^{G2/20} + \dots + 10^{GN/20})^2/4] = 11.58\text{dBi} > 6\text{dBi}$, so the power density limit shall be reduced to $11 - (11.58 - 6) = 5.42\text{dBm}$.
- U-NII-2C Band: Directional gain = $10 \log[(10^{G1/20} + 10^{G2/20} + \dots + 10^{GN/20})^2/4] = 11.62\text{dBi} > 6\text{dBi}$, so the power density limit shall be reduced to $11 - (11.62 - 6) = 5.38\text{dBm}$.

802.11ac (VHT80)

Chan.	Freq. (MHz)	PSD (dBm)				Total PSD w/o duty factor (dBm)	Duty factor	Total PSD with duty factor (dBm)	Max. Limit (dBm)	Pass / Fail
		Chain 0	Chain 1	Chain 2	Chain 3					
58	5290	-7.80	-8.41	-7.84	-9.00	-2.22	0.18	-2.04	5.42	Pass
106	5530	-8.38	-8.74	-8.41	-9.29	-2.67	0.18	-2.49	5.38	Pass
122	5610	-1.29	-2.18	-1.33	-3.29	4.07	0.18	4.25	5.38	Pass
138	5690	-1.80	-2.42	-1.98	-2.39	3.88	0.18	4.06	5.38	Pass

Note:

- Method 1 of power density measurement of KDB 662911 is using for calculating total power density. Total power density is summing entire spectra across corresponding frequency bins on the various outputs by computer.
- U-NII-2A Band: Directional gain = $10 \log[(10^{G1/20} + 10^{G2/20} + \dots + 10^{GN/20})^2/4] = 11.58\text{dBi} > 6\text{dBi}$, so the power density limit shall be reduced to $11 - (11.58 - 6) = 5.42\text{dBm}$.
- U-NII-2C Band: Directional gain = $10 \log[(10^{G1/20} + 10^{G2/20} + \dots + 10^{GN/20})^2/4] = 11.62\text{dBi} > 6\text{dBi}$, so the power density limit shall be reduced to $11 - (11.62 - 6) = 5.38\text{dBm}$.
- Refer to section 3.3 for duty cycle spectrum plot.

Spectrum Plot of Worst Value

802.11a / Chain 2 / CH 144

802.11ac (VHT20) / Chain 0 / CH 144

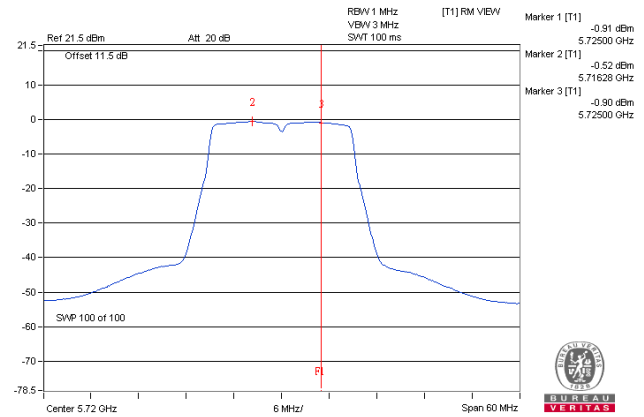
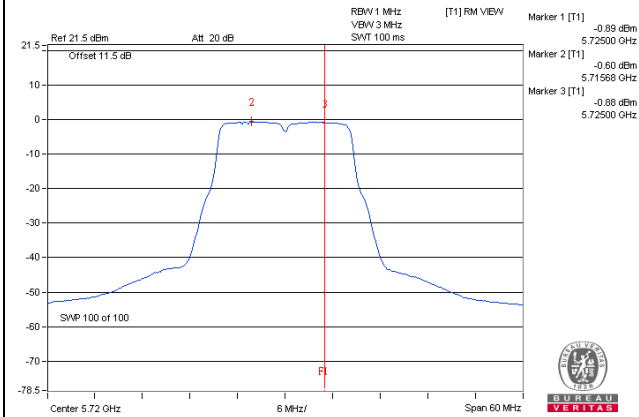

802.11ac (VHT40) / Chain 0 / CH 110

802.11ac (VHT80) / Chain 0 / CH 122

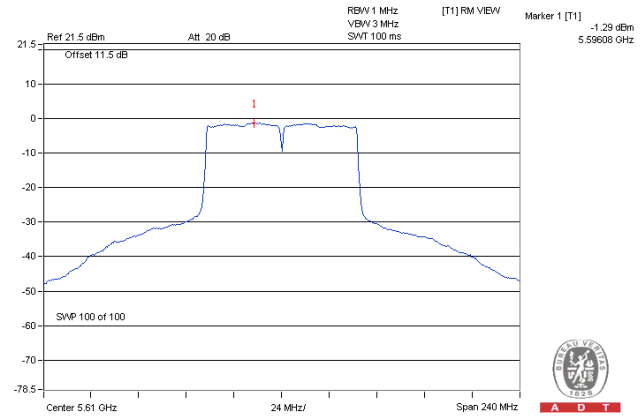
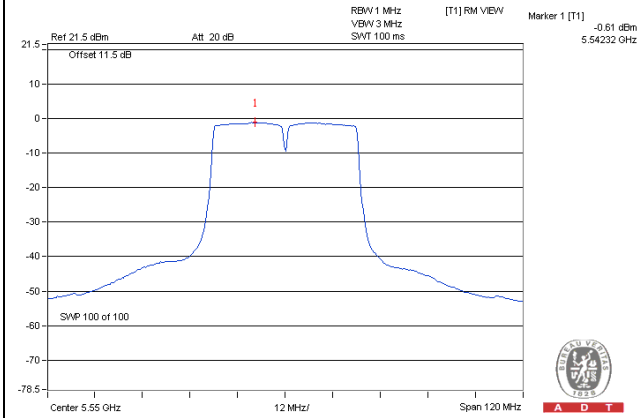

Radio 2 - 2TX CDD Mode

802.11a

Chan.	Freq. (MHz)	PSD (dBm)		Total PSD (dBm)	Max. Limit (dBm)	Pass / Fail
		Chain 2	Chain 3			
52	5260	5.02	4.06	7.58	8.25	Pass
60	5300	5.13	4.34	7.76	8.25	Pass
64	5320	5.18	4.42	7.83	8.25	Pass
100	5500	4.45	3.86	7.18	8.28	Pass
116	5580	4.17	3.69	6.95	8.28	Pass
140	5700	3.90	4.26	7.09	8.28	Pass
144	5720	4.90	4.24	7.59	8.28	Pass

Note:

- Method 1 of power density measurement of KDB 662911 is using for calculating total power density. Total power density is summing entire spectra across corresponding frequency bins on the various outputs by computer.
- U-NII-2A Band: Directional gain = $10 \log[(10^{G1/20} + 10^{G2/20} + \dots + 10^{GN/20})^2/2] = 8.75\text{dBi} > 6\text{dBi}$, so the power density limit shall be reduced to $11-(8.75-6) = 8.25\text{dBm}$.
- U-NII-2C Band: Directional gain = $10 \log[(10^{G1/20} + 10^{G2/20} + \dots + 10^{GN/20})^2/2] = 8.72\text{dBi} > 6\text{dBi}$, so the power density limit shall be reduced to $11-(8.72-6) = 8.28\text{dBm}$.

802.11ac (VHT20)

Chan.	Freq. (MHz)	PSD (dBm)		Total PSD (dBm)	Max. Limit (dBm)	Pass / Fail
		Chain 2	Chain 3			
52	5260	5.00	4.31	7.68	8.25	Pass
60	5300	4.70	4.14	7.44	8.25	Pass
64	5320	4.83	4.05	7.47	8.25	Pass
100	5500	4.27	3.75	7.03	8.28	Pass
116	5580	5.14	4.44	7.81	8.28	Pass
140	5700	4.14	3.31	6.76	8.28	Pass
144	5720	5.07	4.52	7.81	8.28	Pass

Note:

- Method 1 of power density measurement of KDB 662911 is using for calculating total power density. Total power density is summing entire spectra across corresponding frequency bins on the various outputs by computer.
- U-NII-2A Band: Directional gain = $10 \log[(10^{G1/20} + 10^{G2/20} + \dots + 10^{GN/20})^2/2] = 8.75\text{dBi} > 6\text{dBi}$, so the power density limit shall be reduced to $11-(8.75-6) = 8.25\text{dBm}$.
- U-NII-2C Band: Directional gain = $10 \log[(10^{G1/20} + 10^{G2/20} + \dots + 10^{GN/20})^2/2] = 8.72\text{dBi} > 6\text{dBi}$, so the power density limit shall be reduced to $11-(8.72-6) = 8.28\text{dBm}$.

802.11ac (VHT40)

Chan.	Freq. (MHz)	PSD (dBm)		Total PSD (dBm)	Max. Limit (dBm)	Pass / Fail
		Chain 2	Chain 3			
54	5270	4.13	2.39	6.36	8.25	Pass
62	5310	-1.28	-2.07	1.35	8.25	Pass
102	5510	-1.04	-2.31	1.38	8.28	Pass
110	5550	4.27	3.07	6.72	8.28	Pass
134	5670	1.59	0.10	3.92	8.28	Pass
142	5710	4.37	3.32	6.89	8.28	Pass

Note:

- Method 1 of power density measurement of KDB 662911 is using for calculating total power density. Total power density is summing entire spectra across corresponding frequency bins on the various outputs by computer.
- U-NII-2A Band: Directional gain = $10 \log[(10^{G1/20} + 10^{G2/20} + \dots + 10^{GN/20})^2/2] = 8.75\text{dBi} > 6\text{dBi}$, so the power density limit shall be reduced to $11-(8.75-6) = 8.25\text{dBm}$.
- U-NII-2C Band: Directional gain = $10 \log[(10^{G1/20} + 10^{G2/20} + \dots + 10^{GN/20})^2/2] = 8.72\text{dBi} > 6\text{dBi}$, so the power density limit shall be reduced to $11-(8.72-6) = 8.28\text{dBm}$.

802.11ac (VHT80)

Chan.	Freq. (MHz)	PSD (dBm)		Total PSD w/o duty factor (dBm)	Duty factor	Total PSD with duty factor (dBm)	Max. Limit (dBm)	Pass / Fail
		Chain 2	Chain 3					
58	5290	-8.62	-9.02	-5.81	0.18	-5.63	8.25	Pass
106	5530	-7.94	-8.40	-5.16	0.18	-4.98	8.28	Pass
122	5610	-1.06	-2.09	1.46	0.18	1.64	8.28	Pass
138	5690	-0.05	-0.54	2.72	0.18	2.90	8.28	Pass

Note:

- Method 1 of power density measurement of KDB 662911 is using for calculating total power density. Total power density is summing entire spectra across corresponding frequency bins on the various outputs by computer.
- U-NII-2A Band: Directional gain = $10 \log[(10^{G1/20} + 10^{G2/20} + \dots + 10^{GN/20})^2/2] = 8.75\text{dBi} > 6\text{dBi}$, so the power density limit shall be reduced to $11-(8.75-6) = 8.25\text{dBm}$.
- U-NII-2C Band: Directional gain = $10 \log[(10^{G1/20} + 10^{G2/20} + \dots + 10^{GN/20})^2/2] = 8.72\text{dBi} > 6\text{dBi}$, so the power density limit shall be reduced to $11-(8.72-6) = 8.28\text{dBm}$.
- Refer to section 3.3 for duty cycle spectrum plot.

Spectrum Plot of Worst Value

802.11a / Chain 2 / CH 64

802.11ac (VHT20) / Chain 2 / CH 116

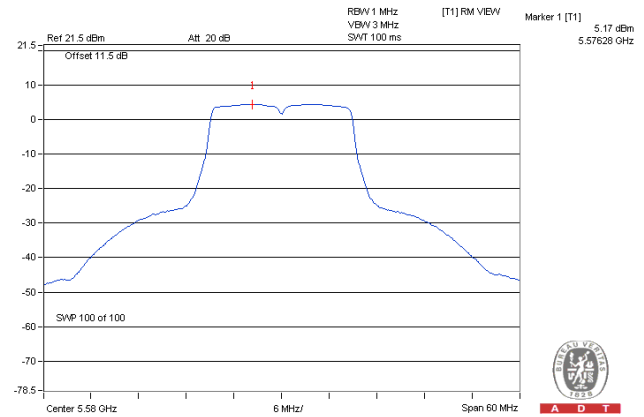
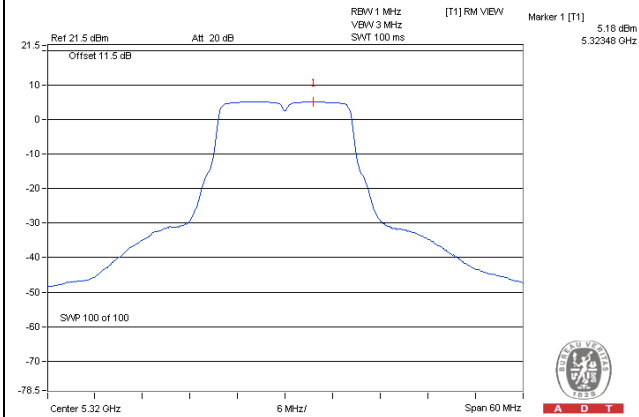

802.11ac (VHT40) / Chain 2 / CH 142

802.11ac (VHT80) / Chain 2 / CH 138

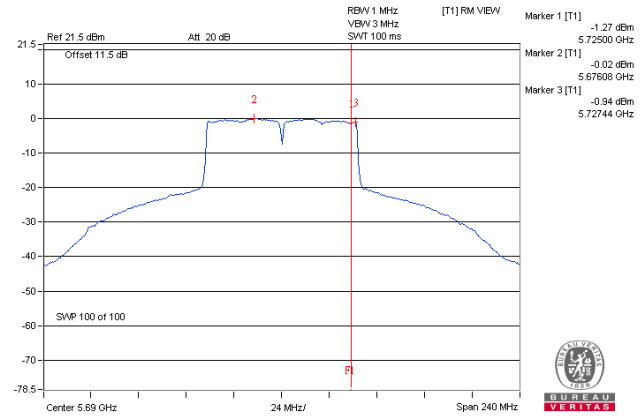
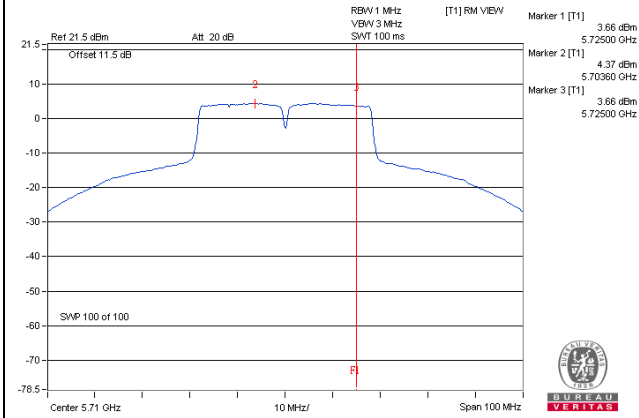

For U-NII-3 Band

Radio 1 - 4TX CDD Mode

802.11a

TX chain	Chan.	Freq. (MHz)	PSD (dBm/300 kHz)	PSD (dBm/500 kHz)	10 log (N=4) dB	Total PSD (dBm/500 kHz)	Limit (dBm/500 kHz)	Pass / Fail
0	144	5720	-8.79	-6.57	6.02	-0.55	24.19	Pass
1	144	5720	-9.37	-7.15	6.02	-1.13	24.19	Pass
2	144	5720	-9.59	-7.37	6.02	-1.35	24.19	Pass
3	144	5720	-9.07	-6.85	6.02	-0.83	24.19	Pass

Note: Directional gain = $10 \log[(10^{G1/20} + 10^{G2/20} + \dots + 10^{GN/20})^2/4] = 11.81 \text{dBi} > 6 \text{dBi}$, so the power density limit shall be reduced to $30 - (11.81 - 6) = 24.19 \text{dBm}$.

802.11ac (VHT20)

TX chain	Chan.	Freq. (MHz)	PSD (dBm/300 kHz)	PSD (dBm/500 kHz)	10 log (N=4) dB	Total PSD (dBm/500 kHz)	Limit (dBm/500 kHz)	Pass / Fail
0	144	5720	-8.92	-6.70	6.02	-0.68	24.19	Pass
1	144	5720	-9.78	-7.56	6.02	-1.54	24.19	Pass
2	144	5720	-9.05	-6.83	6.02	-0.81	24.19	Pass
3	144	5720	-9.42	-7.20	6.02	-1.18	24.19	Pass

Note: Directional gain = $10 \log[(10^{G1/20} + 10^{G2/20} + \dots + 10^{GN/20})^2/4] = 11.81 \text{dBi} > 6 \text{dBi}$, so the power density limit shall be reduced to $30 - (11.81 - 6) = 24.19 \text{dBm}$.

802.11ac (VHT40)

TX chain	Chan.	Freq. (MHz)	PSD (dBm/300 kHz)	PSD (dBm/500 kHz)	10 log (N=4) dB	Total PSD (dBm/500 kHz)	Limit (dBm/500 kHz)	Pass / Fail
0	142	5710	-9.91	-7.69	6.02	-1.67	24.19	Pass
1	142	5710	-10.71	-8.49	6.02	-2.47	24.19	Pass
2	142	5710	-10.53	-8.31	6.02	-2.29	24.19	Pass
3	142	5710	-9.49	-7.27	6.02	-1.25	24.19	Pass

Note: Directional gain = $10 \log[(10^{G1/20} + 10^{G2/20} + \dots + 10^{GN/20})^2/4] = 11.81 \text{dBi} > 6 \text{dBi}$, so the power density limit shall be reduced to $30 - (11.81 - 6) = 24.19 \text{dBm}$.

802.11ac (VHT80)

TX chain	Chan.	Freq. (MHz)	PSD (dBm/300 kHz)	PSD (dBm/500 kHz)	10 log (N=4) dB	Duty factor	Total PSD (dBm/500 kHz)	Limit (dBm/500 kHz)	Pass / Fail
0	138	5690	-11.62	-9.40	6.02	0.18	-3.20	24.19	Pass
1	138	5690	-12.42	-10.20	6.02	0.18	-4.00	24.19	Pass
2	138	5690	-13.25	-11.03	6.02	0.18	-4.83	24.19	Pass
3	138	5690	-12.77	-10.55	6.02	0.18	-4.35	24.19	Pass

Note:

- Directional gain = $10 \log[(10^{G1/20} + 10^{G2/20} + \dots + 10^{GN/20})^2/4] = 11.81\text{dBi} > 6\text{dBi}$, so the power density limit shall be reduced to $30 - (11.81 - 6) = 24.19\text{dBm}$.
- Refer to section 3.3 for duty cycle spectrum plot.

Spectrum Plot of Worst Value

802.11a

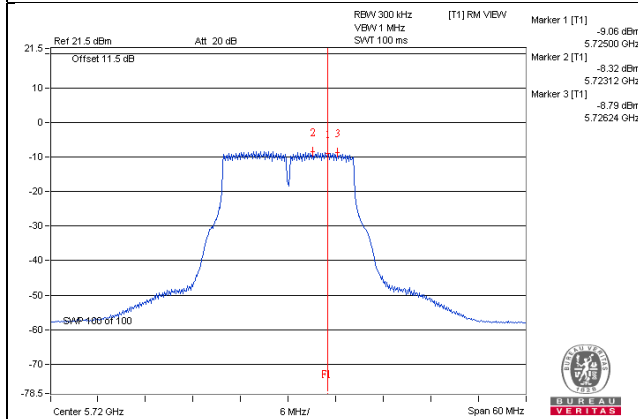

802.11ac (VHT20)

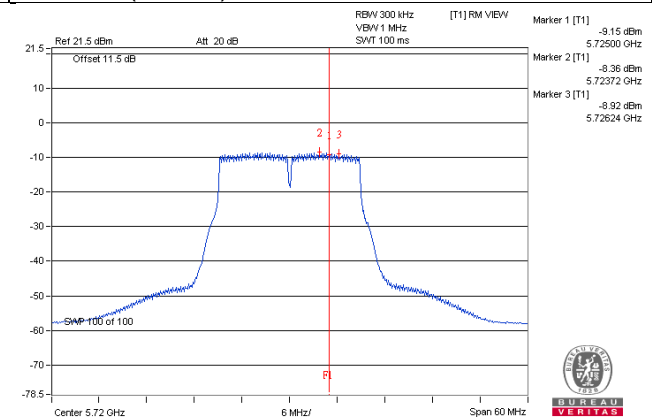

802.11ac (VHT40)

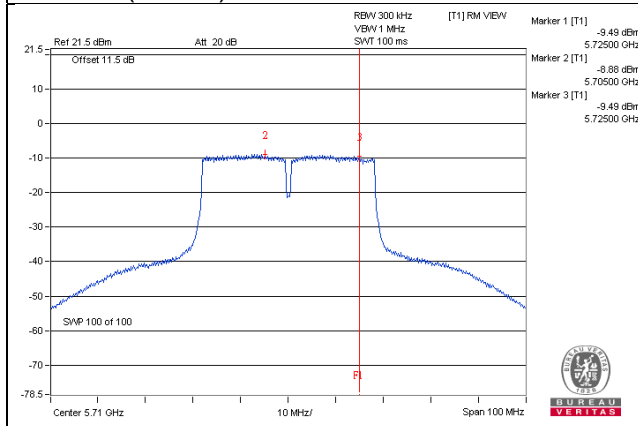

802.11ac (VHT80)

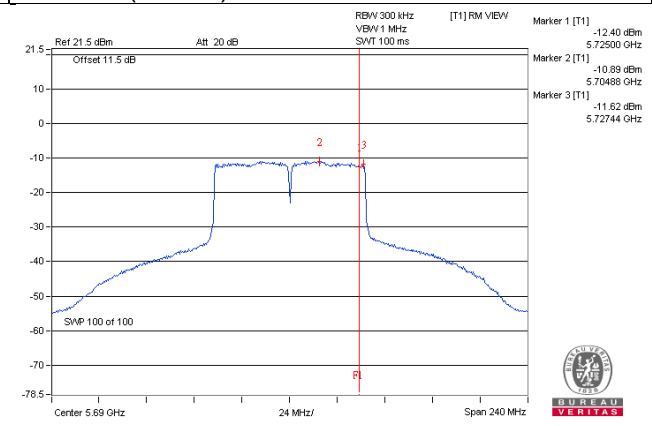

Radio 1 - 2TX CDD Mode

802.11a

TX chain	Chan.	Freq. (MHz)	PSD (dBm/300 kHz)	PSD (dBm/500 kHz)	10 log (N=2) dB	Total PSD (dBm/500 kHz)	Limit (dBm/500 kHz)	Pass / Fail
1	144	5720	-3.48	-1.26	3.01	1.75	27.17	Pass
3	144	5720	-4.16	-1.94	3.01	1.07	27.17	Pass

Note: Directional gain = $10 \log[(10^{G1/20} + 10^{G2/20} + \dots + 10^{GN/20})^2/2] = 8.83\text{dBi} > 6\text{dBi}$, so the power density limit shall be reduced to $30 - (8.83 - 6) = 27.17\text{dBm}$.

802.11ac (VHT20)

TX chain	Chan.	Freq. (MHz)	PSD (dBm/300 kHz)	PSD (dBm/500 kHz)	10 log (N=2) dB	Total PSD (dBm/500 kHz)	Limit (dBm/500 kHz)	Pass / Fail
1	144	5720	-3.34	-1.12	3.01	1.89	27.17	Pass
3	144	5720	-3.77	-1.55	3.01	1.46	27.17	Pass

Note: Directional gain = $10 \log[(10^{G1/20} + 10^{G2/20} + \dots + 10^{GN/20})^2/2] = 8.83\text{dBi} > 6\text{dBi}$, so the power density limit shall be reduced to $30 - (8.83 - 6) = 27.17\text{dBm}$.

802.11ac (VHT40)

TX chain	Chan.	Freq. (MHz)	PSD (dBm/300 kHz)	PSD (dBm/500 kHz)	10 log (N=2) dB	Total PSD (dBm/500 kHz)	Limit (dBm/500 kHz)	Pass / Fail
1	142	5710	-5.17	-2.95	3.01	0.06	27.17	Pass
3	142	5710	-5.54	-3.32	3.01	-0.31	27.17	Pass

Note: Directional gain = $10 \log[(10^{G1/20} + 10^{G2/20} + \dots + 10^{GN/20})^2/2] = 8.83\text{dBi} > 6\text{dBi}$, so the power density limit shall be reduced to $30 - (8.83 - 6) = 27.17\text{dBm}$.

802.11ac (VHT80)

TX chain	Chan.	Freq. (MHz)	PSD (dBm/300 kHz)	PSD (dBm/500 kHz)	10 log (N=2) dB	Duty factor	Total PSD (dBm/500 kHz)	Limit (dBm/500 kHz)	Pass / Fail
1	138	5690	-10.24	-8.02	3.01	0.18	-4.83	27.17	Pass
3	138	5690	-10.95	-8.73	3.01	0.18	-5.54	27.17	Pass

Note:

- Directional gain = $10 \log[(10^{G1/20} + 10^{G2/20} + \dots + 10^{GN/20})^2/2] = 8.83\text{dBi} > 6\text{dBi}$, so the power density limit shall be reduced to $30 - (8.83 - 6) = 27.17\text{dBm}$.
- Refer to section 3.3 for duty cycle spectrum plot.

Spectrum Plot of Worst Value

802.11a

802.11ac (VHT20)

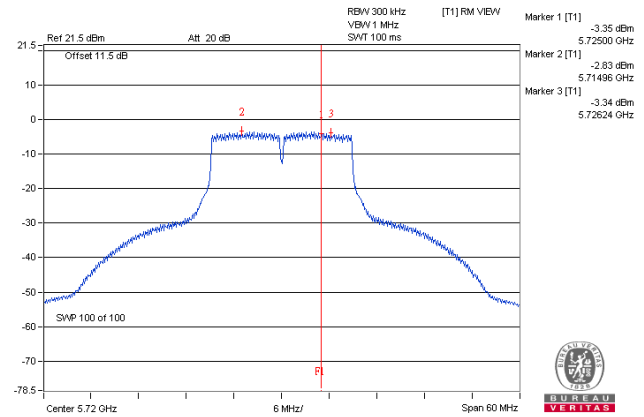
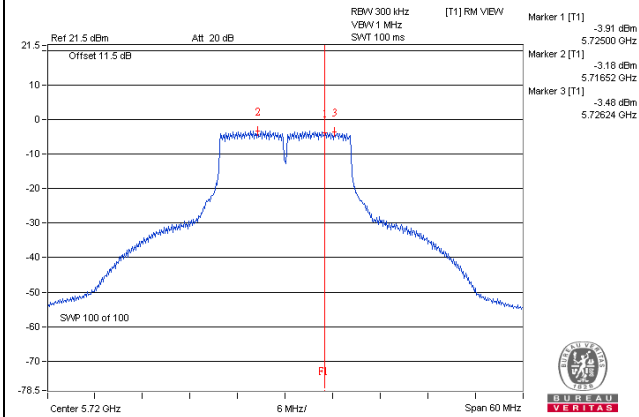

802.11ac (VHT40)

802.11ac (VHT80)

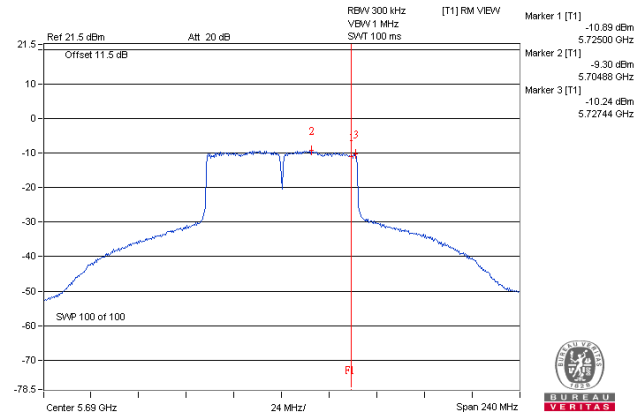
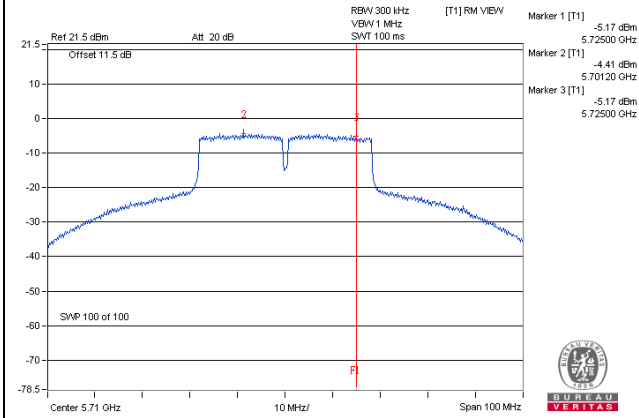

Radio 2 - 4TX CDD Mode

802.11a

TX chain	Chan.	Freq. (MHz)	PSD (dBm/300 kHz)	PSD (dBm/500 kHz)	10 log (N=4) dB	Total PSD (dBm/500 kHz)	Limit (dBm/500 kHz)	Pass / Fail
0	144	5720	-8.85	-6.63	6.02	-0.61	24.30	Pass
1	144	5720	-9.53	-7.31	6.02	-1.29	24.30	Pass
2	144	5720	-9.70	-7.48	6.02	-1.46	24.30	Pass
3	144	5720	-9.49	-7.27	6.02	-1.25	24.30	Pass

Note: Directional gain = $10 \log[(10^{G1/20} + 10^{G2/20} + \dots + 10^{GN/20})^2/4] = 11.70\text{dBi} > 6\text{dBi}$, so the power density limit shall be reduced to $30-(11.70-6) = 24.30\text{dBm}$.

802.11ac (VHT20)

TX chain	Chan.	Freq. (MHz)	PSD (dBm/300 kHz)	PSD (dBm/500 kHz)	10 log (N=4) dB	Total PSD (dBm/500 kHz)	Limit (dBm/500 kHz)	Pass / Fail
0	144	5720	-8.59	-6.37	6.02	-0.35	24.30	Pass
1	144	5720	-9.83	-7.61	6.02	-1.59	24.30	Pass
2	144	5720	-10.02	-7.80	6.02	-1.78	24.30	Pass
3	144	5720	-10.09	-7.87	6.02	-1.85	24.30	Pass

Note: Directional gain = $10 \log[(10^{G1/20} + 10^{G2/20} + \dots + 10^{GN/20})^2/4] = 11.70\text{dBi} > 6\text{dBi}$, so the power density limit shall be reduced to $30-(11.70-6) = 24.30\text{dBm}$.

802.11ac (VHT40)

TX chain	Chan.	Freq. (MHz)	PSD (dBm/300 kHz)	PSD (dBm/500 kHz)	10 log (N=4) dB	Total PSD (dBm/500 kHz)	Limit (dBm/500 kHz)	Pass / Fail
0	142	5710	-9.83	-7.61	6.02	-1.59	24.30	Pass
1	142	5710	-10.57	-8.35	6.02	-2.33	24.30	Pass
2	142	5710	-9.72	-7.50	6.02	-1.48	24.30	Pass
3	142	5710	-11.15	-8.93	6.02	-2.91	24.30	Pass

Note: Directional gain = $10 \log[(10^{G1/20} + 10^{G2/20} + \dots + 10^{GN/20})^2/4] = 11.70\text{dBi} > 6\text{dBi}$, so the power density limit shall be reduced to $30-(11.70-6) = 24.30\text{dBm}$.

802.11ac (VHT80)

TX chain	Chan.	Freq. (MHz)	PSD (dBm/300 kHz)	PSD (dBm/500 kHz)	10 log (N=4) dB	Duty factor	Total PSD (dBm/500 kHz)	Limit (dBm/500 kHz)	Pass / Fail
0	138	5690	-11.54	-9.32	6.02	0.18	-3.12	24.30	Pass
1	138	5690	-11.65	-9.43	6.02	0.18	-3.23	24.30	Pass
2	138	5690	-11.21	-8.99	6.02	0.18	-2.79	24.30	Pass
3	138	5690	-11.52	-9.30	6.02	0.18	-3.10	24.30	Pass

Note:

- Directional gain = $10 \log[(10^{G1/20} + 10^{G2/20} + \dots + 10^{GN/20})^2/4] = 11.70\text{dBi} > 6\text{dBi}$, so the power density limit shall be reduced to $30 - (11.70 - 6) = 24.30\text{dBm}$.
- Refer to section 3.3 for duty cycle spectrum plot.

Spectrum Plot of Worst Value

802.11a

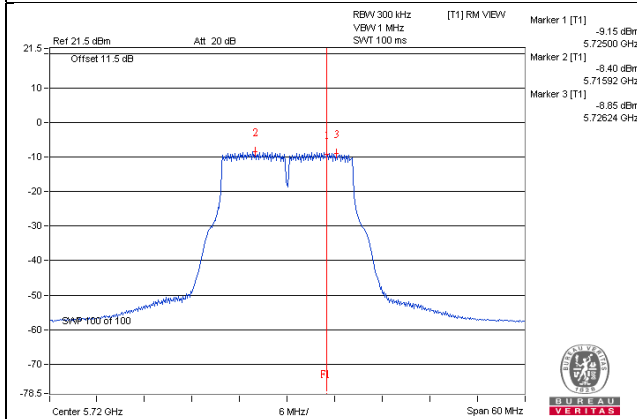

802.11ac (VHT20)

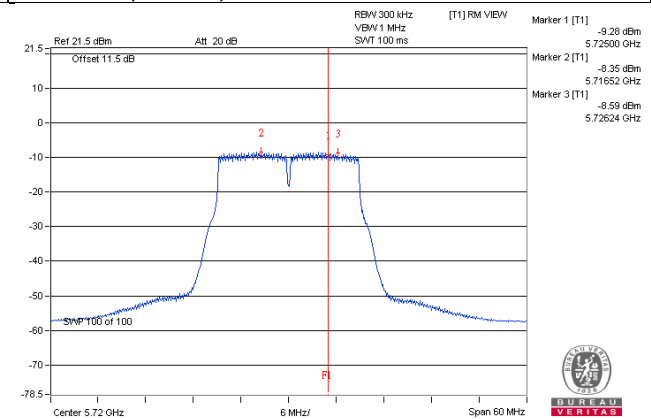

802.11ac (VHT40)

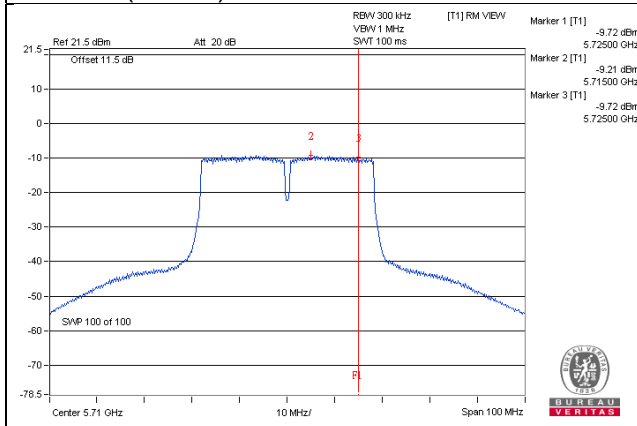

802.11ac (VHT80)

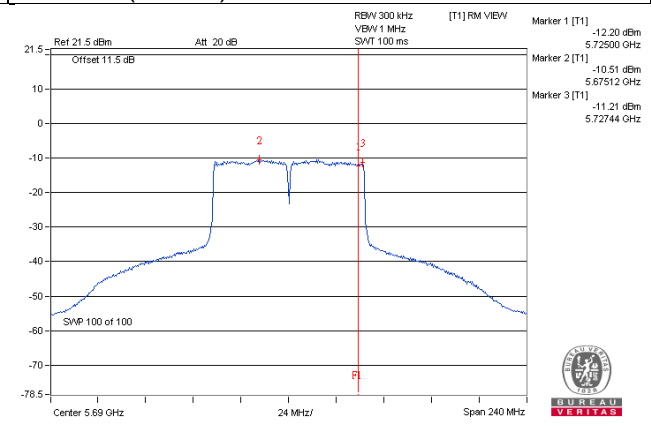

Radio 2 - 2TX CDD Mode

802.11a

TX chain	Chan.	Freq. (MHz)	PSD (dBm/300 kHz)	PSD (dBm/500 kHz)	10 log (N=2) dB	Total PSD (dBm/500 kHz)	Limit (dBm/500 kHz)	Pass / Fail
2	144	5720	-3.13	-0.91	3.01	2.10	27.30	Pass
3	144	5720	-3.93	-1.71	3.01	1.30	27.30	Pass

Note: Directional gain = $10 \log[(10^{G1/20} + 10^{G2/20} + \dots + 10^{GN/20})^2/2] = 8.70\text{dBi} > 6\text{dBi}$, so the power density limit shall be reduced to $30 - (8.70 - 6) = 27.30\text{dBm}$.

802.11ac (VHT20)

TX chain	Chan.	Freq. (MHz)	PSD (dBm/300 kHz)	PSD (dBm/500 kHz)	10 log (N=2) dB	Total PSD (dBm/500 kHz)	Limit (dBm/500 kHz)	Pass / Fail
2	144	5720	-3.75	-1.53	3.01	1.48	27.30	Pass
3	144	5720	-4.33	-2.11	3.01	0.90	27.30	Pass

Note: Directional gain = $10 \log[(10^{G1/20} + 10^{G2/20} + \dots + 10^{GN/20})^2/2] = 8.70\text{dBi} > 6\text{dBi}$, so the power density limit shall be reduced to $30 - (8.70 - 6) = 27.30\text{dBm}$.

802.11ac (VHT40)

TX chain	Chan.	Freq. (MHz)	PSD (dBm/300 kHz)	PSD (dBm/500 kHz)	10 log (N=2) dB	Total PSD (dBm/500 kHz)	Limit (dBm/500 kHz)	Pass / Fail
2	142	5710	-4.32	-2.10	3.01	0.91	27.30	Pass
3	142	5710	-5.64	-3.42	3.01	-0.41	27.30	Pass

Note: Directional gain = $10 \log[(10^{G1/20} + 10^{G2/20} + \dots + 10^{GN/20})^2/2] = 8.70\text{dBi} > 6\text{dBi}$, so the power density limit shall be reduced to $30 - (8.70 - 6) = 27.30\text{dBm}$.

802.11ac (VHT80)

TX chain	Chan.	Freq. (MHz)	PSD (dBm/300 kHz)	PSD (dBm/500 kHz)	10 log (N=2) dB	Duty factor	Total PSD (dBm/500 kHz)	Limit (dBm/500 kHz)	Pass / Fail
2	138	5690	-9.24	-7.02	3.01	0.18	-3.83	27.30	Pass
3	138	5690	-9.94	-7.72	3.01	0.18	-4.53	27.30	Pass

Note:

- Directional gain = $10 \log[(10^{G1/20} + 10^{G2/20} + \dots + 10^{GN/20})^2/2] = 8.70\text{dBi} > 6\text{dBi}$, so the power density limit shall be reduced to $30 - (8.70 - 6) = 27.30\text{dBm}$.
- Refer to section 3.3 for duty cycle spectrum plot.

Spectrum Plot of Worst Value

802.11a

802.11ac (VHT20)

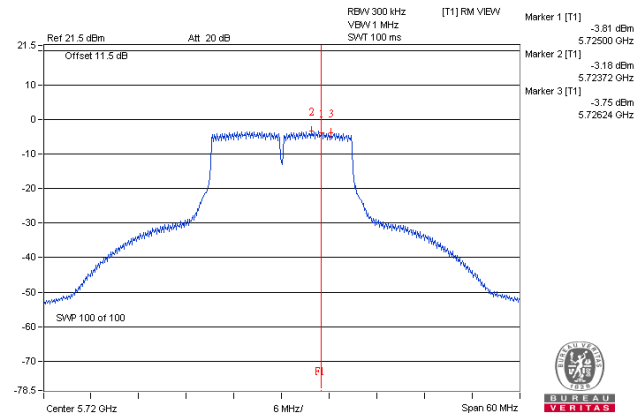
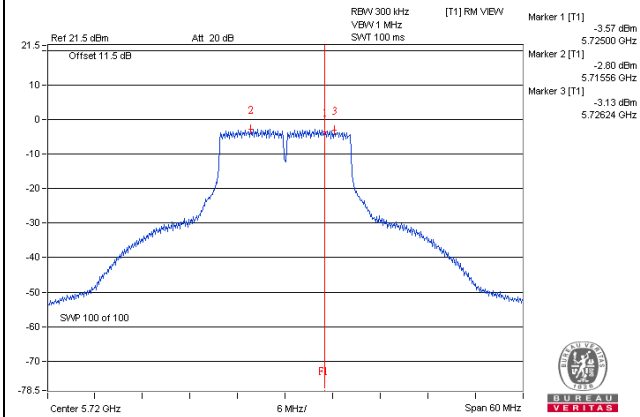

802.11ac (VHT40)

802.11ac (VHT80)

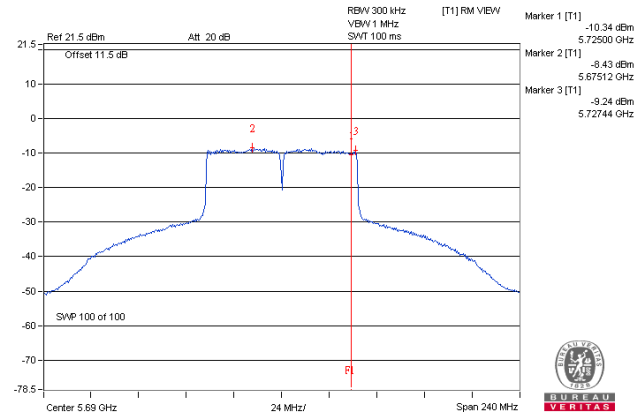
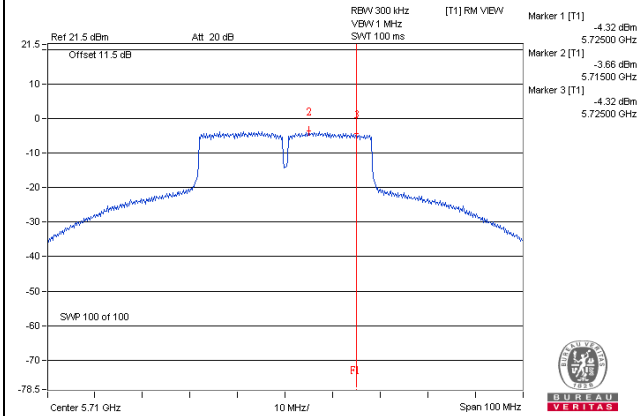

4.6 Frequency Stability

4.6.1 Limits of Frequency Stability Measurement

The frequency of the carrier signal shall be maintained within band of operation

4.6.2 Test Setup

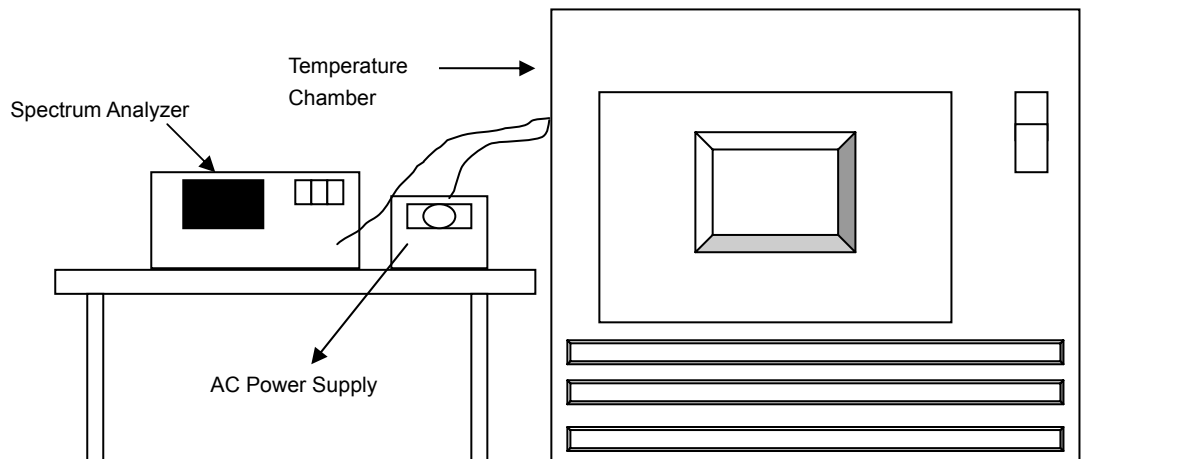

4.6.3 Test Instruments

Refer to section 4.1.2 to get information of above instrument.

4.6.4 Test Procedure

- The EUT was placed inside the environmental test chamber and powered by nominal AC voltage.
- Turn the EUT on and couple its output to a spectrum analyzer.
- Turn the EUT off and set the chamber to the highest temperature specified.
- Allow sufficient time (approximately 30 min) for the temperature of the chamber to stabilize, turn the EUT on and measure the operating frequency after 2, 5, and 10 minutes.
- Repeat step 2 and 3 with the temperature chamber set to the lowest temperature.
- The test chamber was allowed to stabilize at +20 degree C for a minimum of 30 minutes. The supply voltage was then adjusted on the EUT from 85% to 115% and the frequency record.

4.6.5 Deviation from Test Standard

No deviation.

4.6.6 EUT Operating Condition

Set the EUT transmit at un-modulation mode to test frequency stability.

4.6.7 Test Results

Radio 1

Frequency Stability Versus Temp.									
Operating Frequency: 5260MHz									
Temp. (°C)	Power Supply (Vac)	0 Minute		2 Minute		5 Minute		10 Minute	
		Measured Frequency (MHz)	Result	Measured Frequency (MHz)	Result	Measured Frequency (MHz)	Result	Measured Frequency (MHz)	Result
50	120	5260.024	Pass	5260.0237	Pass	5260.0249	Pass	5260.0259	Pass
40	120	5260.0058	Pass	5260.0058	Pass	5260.0039	Pass	5260.0052	Pass
30	120	5260.0082	Pass	5260.0096	Pass	5260.0084	Pass	5260.0106	Pass
20	120	5260.0238	Pass	5260.026	Pass	5260.0251	Pass	5260.0251	Pass
10	120	5259.9767	Pass	5259.9768	Pass	5259.9792	Pass	5259.98	Pass
0	120	5260.0175	Pass	5260.0151	Pass	5260.0163	Pass	5260.0153	Pass
-10	120	5260.017	Pass	5260.021	Pass	5260.0185	Pass	5260.0208	Pass
-20	120	5259.9799	Pass	5259.9829	Pass	5259.9812	Pass	5259.9844	Pass
-30	120	5259.9824	Pass	5259.9838	Pass	5259.9819	Pass	5259.9857	Pass

Frequency Stability Versus Voltage									
Operating Frequency: 5260MHz									
Temp. (°C)	Power Supply (Vac)	0 Minute		2 Minute		5 Minute		10 Minute	
		Measured Frequency (MHz)	Result	Measured Frequency (MHz)	Result	Measured Frequency (MHz)	Result	Measured Frequency (MHz)	Result
20	138	5260.0248	Pass	5260.0265	Pass	5260.0248	Pass	5260.0253	Pass
	120	5260.0238	Pass	5260.026	Pass	5260.0251	Pass	5260.0251	Pass
	102	5260.0248	Pass	5260.0268	Pass	5260.0253	Pass	5260.0255	Pass

Radio 2

Frequency Stability Versus Temp.									
Operating Frequency: 5260MHz									
Temp. (°C)	Power Supply (Vac)	0 Minute		2 Minute		5 Minute		10 Minute	
		Measured Frequency (MHz)	Result	Measured Frequency (MHz)	Result	Measured Frequency (MHz)	Result	Measured Frequency (MHz)	Result
50	120	5259.9955	Pass	5259.9982	Pass	5259.9948	Pass	5259.9957	Pass
40	120	5259.9903	Pass	5259.9862	Pass	5259.9883	Pass	5259.9876	Pass
30	120	5259.9761	Pass	5259.9735	Pass	5259.9731	Pass	5259.9748	Pass
20	120	5259.9793	Pass	5259.9817	Pass	5259.9823	Pass	5259.9823	Pass
10	120	5260.0211	Pass	5260.0219	Pass	5260.0213	Pass	5260.0223	Pass
0	120	5260.0147	Pass	5260.0124	Pass	5260.0156	Pass	5260.0131	Pass
-10	120	5259.9798	Pass	5259.9784	Pass	5259.9809	Pass	5259.9807	Pass
-20	120	5259.9923	Pass	5259.9903	Pass	5259.9897	Pass	5259.994	Pass
-30	120	5260.0219	Pass	5260.0229	Pass	5260.0216	Pass	5260.0204	Pass

Frequency Stability Versus Voltage									
Operating Frequency: 5260MHz									
Temp. (°C)	Power Supply (Vac)	0 Minute		2 Minute		5 Minute		10 Minute	
		Measured Frequency (MHz)	Result	Measured Frequency (MHz)	Result	Measured Frequency (MHz)	Result	Measured Frequency (MHz)	Result
20	138	5259.9783	Pass	5259.9817	Pass	5259.9813	Pass	5259.9826	Pass
	120	5259.9793	Pass	5259.9817	Pass	5259.9823	Pass	5259.9823	Pass
	102	5259.9785	Pass	5259.9809	Pass	5259.9822	Pass	5259.9822	Pass

4.7 6dB Bandwidth Measurement

4.7.1 Limits of 6dB Bandwidth Measurement

The minimum of 6dB Bandwidth Measurement is 0.5MHz.

4.7.2 Test Setup



4.7.3 Test Instruments

Refer to section 4.1.2 to get information of above instrument.

4.7.4 Test Procedure

MEASUREMENT PROCEDURE REF

- Set resolution bandwidth (RBW) = 100kHz
- Set the video bandwidth (VBW) $\geq 3 \times$ RBW, Detector = Peak.
- Trace mode = max hold.
- Sweep = auto couple.
- Measure the maximum width of the emission that is constrained by the frequencies associated with the two amplitude points (upper and lower) that are attenuated by 6 dB relative to the maximum level measured in the fundamental emission

4.7.5 Deviation from Test Standard

No deviation.

4.7.6 EUT Operating Condition

The software provided by client to enable the EUT under transmission condition continuously at lowest, middle and highest channel frequencies individually.

4.7.7 Test Results

Radio 1 - 4TX CDD Mode

802.11a

Channel	Frequency (MHz)	6dB Bandwidth (MHz)				Minimum Limit (MHz)	Pass / Fail
		Chain 0	Chain 1	Chain 2	Chain 3		
144	5720	3.16	3.16	3.79	3.17	0.5	Pass

802.11ac (VHT20)

Channel	Frequency (MHz)	6dB Bandwidth (MHz)				Minimum Limit (MHz)	Pass / Fail
		Chain 0	Chain 1	Chain 2	Chain 3		
144	5720	3.76	3.82	3.17	3.78	0.5	Pass

802.11ac (VHT40)

Channel	Frequency (MHz)	6dB Bandwidth (MHz)				Minimum Limit (MHz)	Pass / Fail
		Chain 0	Chain 1	Chain 2	Chain 3		
142	5710	3.21	3.23	3.22	3.21	0.5	Pass

802.11ac (VHT80)

Channel	Frequency (MHz)	6dB Bandwidth (MHz)				Minimum Limit (MHz)	Pass / Fail
		Chain 0	Chain 1	Chain 2	Chain 3		
138	5690	2.77	3.16	3.08	2.99	0.5	Pass

Spectrum Plot of Worst Value

802.11a

802.11ac (VHT20)

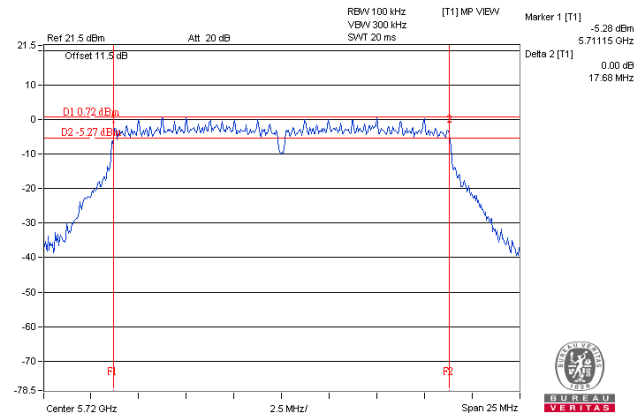
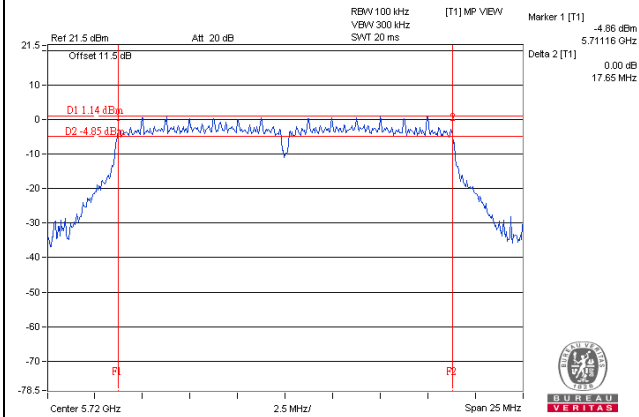

802.11ac (VHT40)

802.11ac (VHT80)

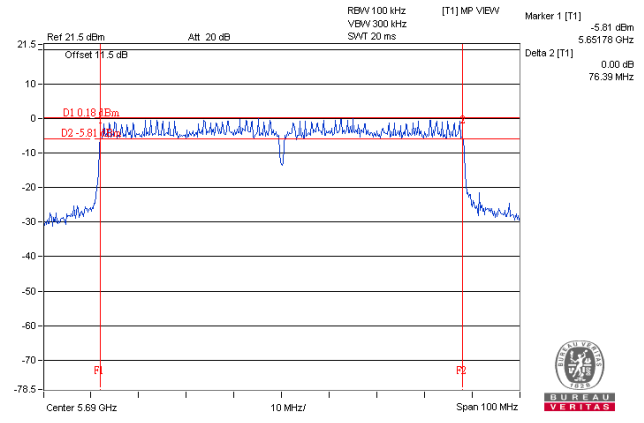
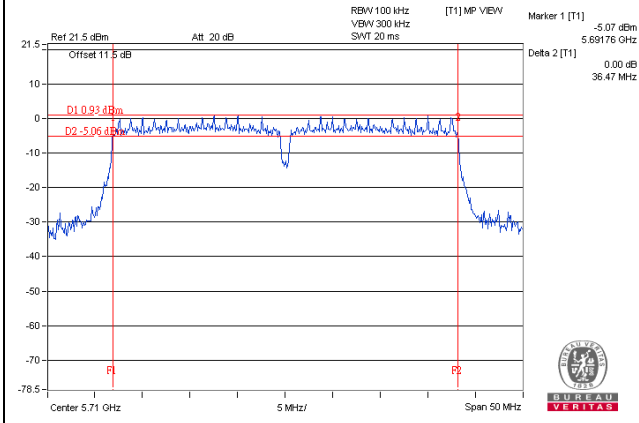

Radio 1 - 2TX CDD Mode

802.11a

Channel	Frequency (MHz)	6dB Bandwidth (MHz)		Minimum Limit (MHz)	Pass / Fail
		Chain 1	Chain 3		
144	5720	3.17	3.15	0.5	Pass

802.11ac (VHT20)

Channel	Frequency (MHz)	6dB Bandwidth (MHz)		Minimum Limit (MHz)	Pass / Fail
		Chain 1	Chain 3		
144	5720	3.78	3.78	0.5	Pass

802.11ac (VHT40)

Channel	Frequency (MHz)	6dB Bandwidth (MHz)		Minimum Limit (MHz)	Pass / Fail
		Chain 1	Chain 3		
142	5710	3.14	3.16	0.5	Pass

802.11ac (VHT80)

Channel	Frequency (MHz)	6dB Bandwidth (MHz)		Minimum Limit (MHz)	Pass / Fail
		Chain 1	Chain 3		
138	5690	2.79	2.76	0.5	Pass

Spectrum Plot of Worst Value

802.11a

802.11ac (VHT20)

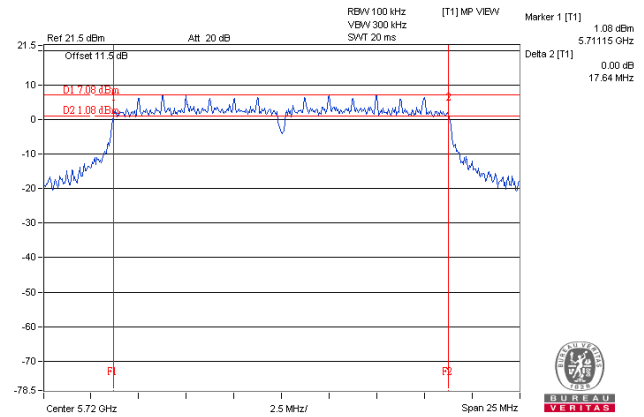
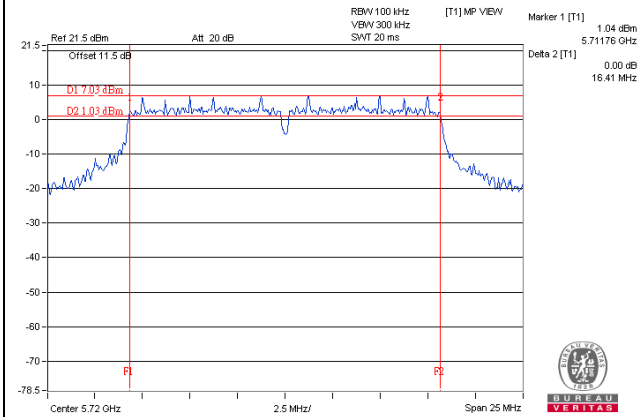

802.11ac (VHT40)

802.11ac (VHT80)

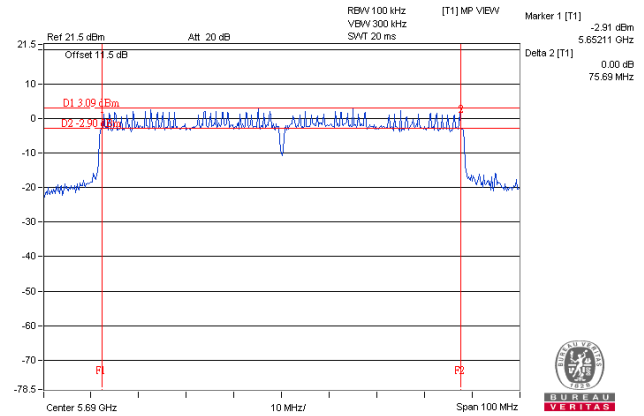
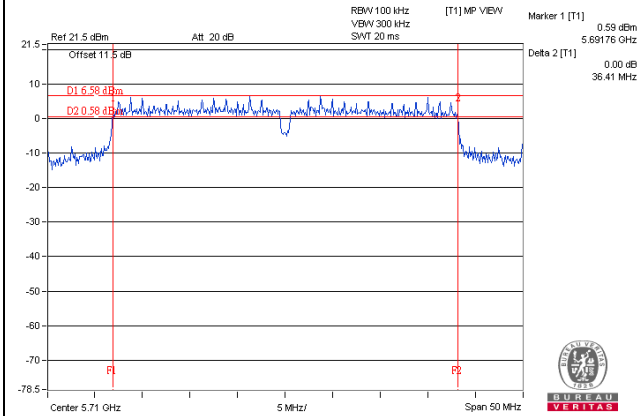

Radio 2 - 4TX CDD Mode

802.11a

Channel	Frequency (MHz)	6dB Bandwidth (MHz)				Minimum Limit (MHz)	Pass / Fail
		Chain 0	Chain 1	Chain 2	Chain 3		
144	5720	3.15	3.17	3.17	3.16	0.5	Pass

802.11ac (VHT20)

Channel	Frequency (MHz)	6dB Bandwidth (MHz)				Minimum Limit (MHz)	Pass / Fail
		Chain 0	Chain 1	Chain 2	Chain 3		
144	5720	3.77	3.77	3.79	3.78	0.5	Pass

802.11ac (VHT40)

Channel	Frequency (MHz)	6dB Bandwidth (MHz)				Minimum Limit (MHz)	Pass / Fail
		Chain 0	Chain 1	Chain 2	Chain 3		
142	5710	3.13	3.20	3.20	3.21	0.5	Pass

802.11ac (VHT80)

Channel	Frequency (MHz)	6dB Bandwidth (MHz)				Minimum Limit (MHz)	Pass / Fail
		Chain 0	Chain 1	Chain 2	Chain 3		
138	5690	2.86	3.11	3.22	3.20	0.5	Pass

Spectrum Plot of Worst Value

802.11a

802.11ac (VHT20)

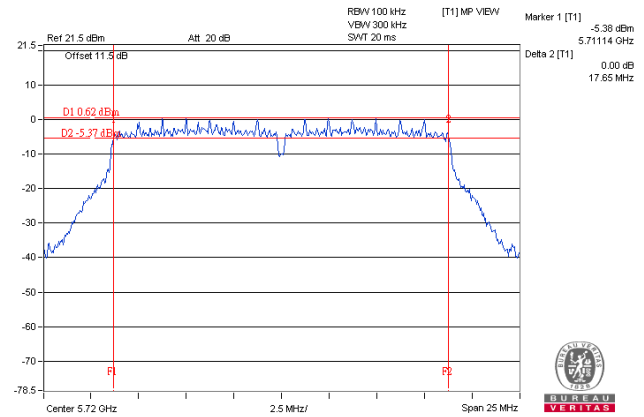
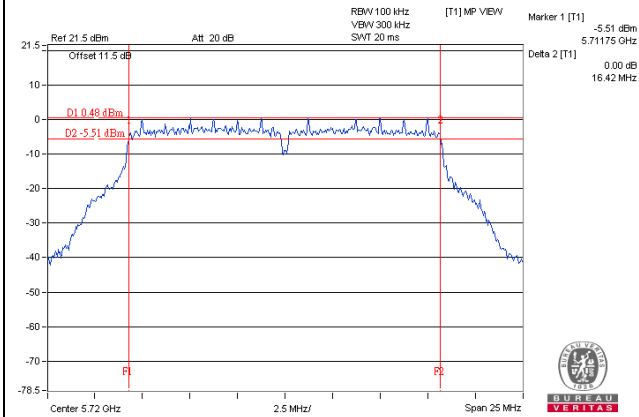

802.11ac (VHT40)

802.11ac (VHT80)

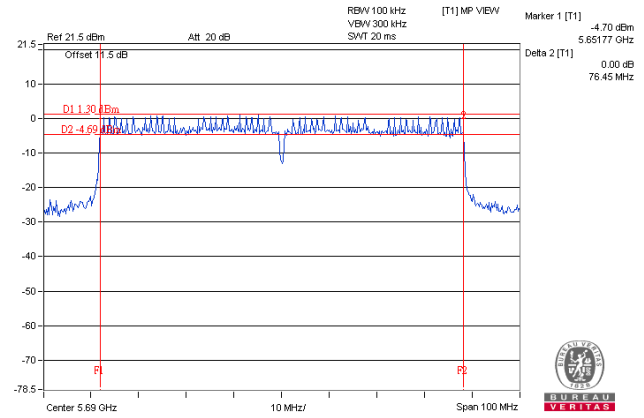
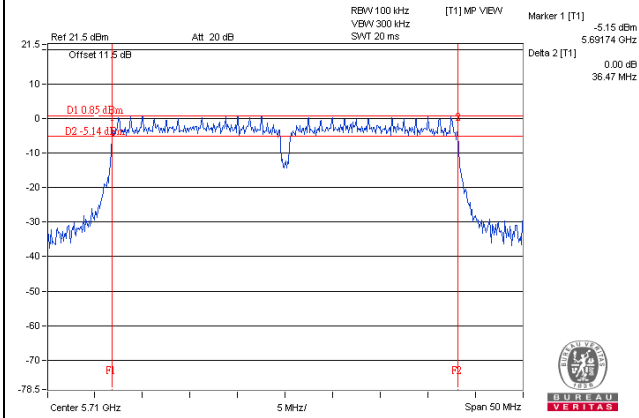

Radio 2 - 2TX CDD Mode

802.11a

Channel	Frequency (MHz)	6dB Bandwidth (MHz)		Minimum Limit (MHz)	Pass / Fail
		Chain 2	Chain 3		
144	5720	3.15	3.17	0.5	Pass

802.11ac (VHT20)

Channel	Frequency (MHz)	6dB Bandwidth (MHz)		Minimum Limit (MHz)	Pass / Fail
		Chain 2	Chain 3		
144	5720	3.78	3.79	0.5	Pass

802.11ac (VHT40)

Channel	Frequency (MHz)	6dB Bandwidth (MHz)		Minimum Limit (MHz)	Pass / Fail
		Chain 2	Chain 3		
142	5710	3.23	3.23	0.5	Pass

802.11ac (VHT80)

Channel	Frequency (MHz)	6dB Bandwidth (MHz)		Minimum Limit (MHz)	Pass / Fail
		Chain 2	Chain 3		
138	5690	3.19	2.86	0.5	Pass

Spectrum Plot of Worst Value

802.11a

802.11ac (VHT20)

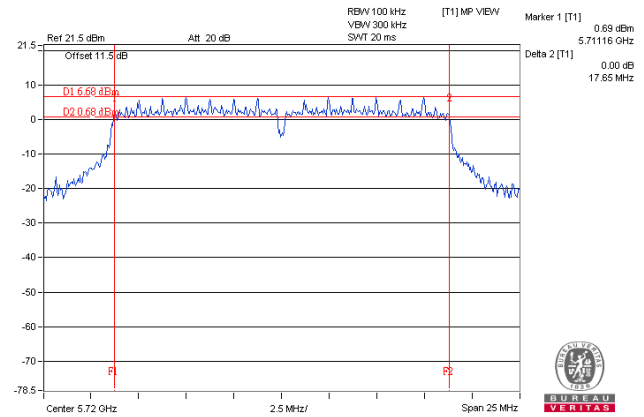
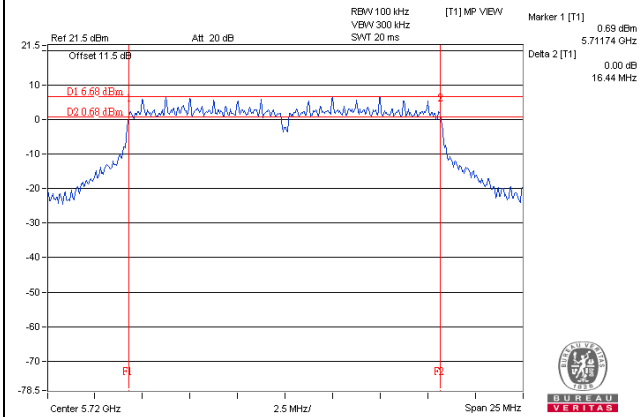

802.11ac (VHT40)

802.11ac (VHT80)

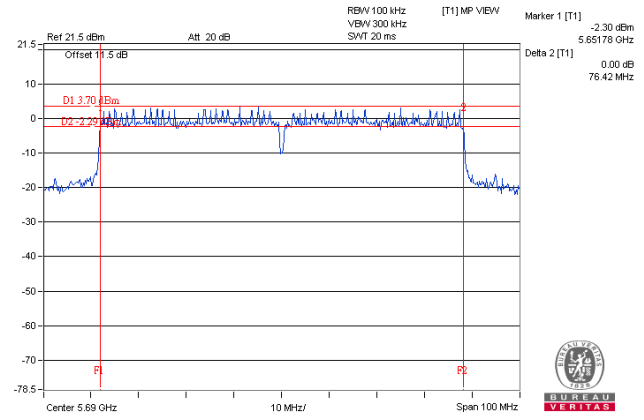
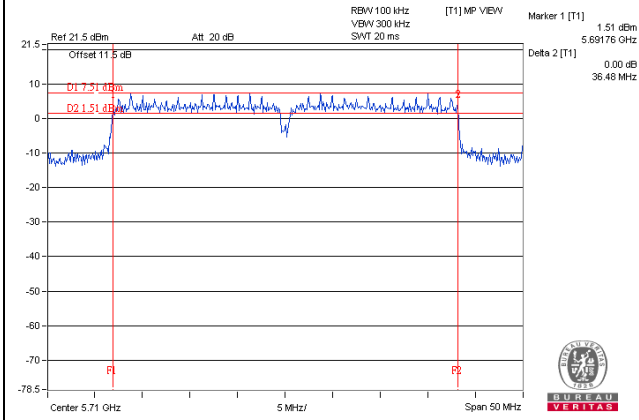

5 Pictures of Test Arrangements

Please refer to the attached file (Test Setup Photo).

Appendix – Information on the Testing Laboratories

We, Bureau Veritas Consumer Products Services (H.K.) Ltd., Taoyuan Branch, were founded in 1988 to provide our best service in EMC, Radio, Telecom and Safety consultation. Our laboratories are accredited and approved according to ISO/IEC 17025.

If you have any comments, please feel free to contact us at the following:

Linko EMC/RF Lab

Tel: 886-2-26052180

Fax: 886-2-26051924

Hsin Chu EMC/RF/Telecom Lab

Tel: 886-3-6668565

Fax: 886-3-6668323

Hwa Ya EMC/RF/Safety

Tel: 886-3-3183232

Fax: 886-3-3270892

Email: service.adt@tw.bureauveritas.com

Web Site: www.bureauveritas-adt.com

The address and road map of all our labs can be found in our web site also.

--- END ---