

FCC Test Report

Report No.: RF160407E10-3

FCC ID: WBV-AP550

Test Model: AP550

Received Date: Apr. 07, 2016

Test Date: May 28 ~ Jun. 17, 2016

Issued Date: Jun. 29, 2016

Applicant: Aerohive Networks Inc.

Address: 1011 McCarthy Blvd, Milpitas, CA 95035, USA

Issued By: Bureau Veritas Consumer Products Services (H.K.) Ltd., Taoyuan Branch

Lab Address: E-2, No.1, Li Hsin 1st Road, Hsinchu Science Park, Hsinchu City 300, Taiwan R.O.C.

Test Location (1): E-2, No.1, Li Hsin 1st Road, Hsinchu Science Park, Hsinchu City 300, Taiwan R.O.C.

Test Location (2): No. 49, Ln. 206, Wende Rd., Shangshan Tsuen, Chiung Lin Hsiang, Hsin Chu Hsien 307, Taiwan R.O.C.



This report is for your exclusive use. Any copying or replication of this report to or for any other person or entity, or use of our name or trademark, is permitted only with our prior written permission. This report sets forth our findings solely with respect to the test samples identified herein. The results set forth in this report are not indicative or representative of the quality or characteristics of the lot from which a test sample was taken or any similar or identical product unless specifically and expressly noted. Our report includes all of the tests requested by you and the results thereof based upon the information that you provided to us. You have 60 days from date of issuance of this report to notify us of any material error or omission caused by our negligence, provided, however, that such notice shall be in writing and shall specifically address the issue you wish to raise. A failure to raise such issue within the prescribed time shall constitute your unqualified acceptance of the completeness of this report, the tests conducted and the correctness of the report contents. Unless specific mention, the uncertainty of measurement has been explicitly taken into account to declare the compliance or non-compliance to the specification. This report should not be used by the client to claim product certification, approval, or endorsement by TAF or any government agencies.

Table of Contents

Release Control Record	4
1 Certificate of Conformity	5
2 Summary of Test Results	6
2.1 Measurement Uncertainty.....	6
2.2 Modification Record.....	6
3 General Information	7
3.1 General Description of EUT.....	7
3.2 Description of Test Modes.....	9
3.2.1 Test Mode Applicability and Tested Channel Detail.....	10
3.3 Description of Support Units.....	12
3.3.1 Configuration of System under Test.....	13
3.4 General Description of Applied Standards.....	14
4 Test Types and Results	15
4.1 Radiated Emission and Bandedge Measurement.....	15
4.1.1 Limits of Radiated Emission and Bandedge Measurement.....	15
4.1.2 Test Instruments.....	16
4.1.3 Test Procedures.....	18
4.1.4 Deviation from Test Standard.....	18
4.1.5 Test Set Up.....	19
4.1.6 EUT Operating Conditions.....	19
4.1.7 Test Results.....	20
4.2 Conducted Emission Measurement.....	25
4.2.1 Limits of Conducted Emission Measurement.....	25
4.2.2 Test Instruments.....	25
4.2.3 Test Procedures.....	25
4.2.4 Deviation from Test Standard.....	26
4.2.5 Test Setup.....	26
4.2.6 EUT Operating Conditions.....	26
4.2.7 Test Results.....	27
4.3 6dB Bandwidth Measurement.....	31
4.3.1 Limits of 6dB Bandwidth Measurement.....	31
4.3.2 Test Setup.....	31
4.3.3 Test Instruments.....	31
4.3.4 Test Procedure.....	31
4.3.5 Deviation from Test Standard.....	31
4.3.6 EUT Operating Conditions.....	31
4.3.7 Test Result.....	32
4.4 Conducted Output Power Measurement.....	33
4.4.1 Limits of Conducted Output Power Measurement.....	33
4.4.2 Test Setup.....	33
4.4.3 Test Instruments.....	33
4.4.4 Test Procedures.....	33
4.4.5 Deviation from Test Standard.....	33
4.4.6 EUT Operating Conditions.....	33
4.4.7 Test Results.....	33
4.5 Power Spectral Density Measurement.....	34
4.5.1 Limits of Power Spectral Density Measurement.....	34
4.5.2 Test Setup.....	34
4.5.3 Test Instruments.....	34
4.5.4 Test Procedure.....	34
4.5.5 Deviation from Test Standard.....	34
4.5.6 EUT Operating Condition.....	34
4.5.7 Test Results.....	35

4.6	Conducted Out of Band Emission Measurement.....	36
4.6.1	Limits of Conducted Out of Band Emission Measurement	36
4.6.2	Test Setup.....	36
4.6.3	Test Instruments	36
4.6.4	Test Procedure	36
4.6.5	Deviation from Test Standard	36
4.6.6	EUT Operating Condition	36
4.6.7	Test Results	37
5	Pictures of Test Arrangements.....	38
	Appendix – Information on the Testing Laboratories	39



BUREAU
VERITAS

Release Control Record

Issue No.	Description	Date Issued
RF160407E10-3	Original release	Jun. 29, 2016

1 Certificate of Conformity

Product: Access Point

Brand: Aerohive

Test Model: AP550

Sample Status: Engineering sample

Applicant: Aerohive Networks Inc.

Test Date: May 28 ~ Jun. 17, 2016

Standards: 47 CFR FCC Part 15, Subpart C (Section 15.247)
ANSI C63.10:2013

The above equipment has been tested by **Bureau Veritas Consumer Products Services (H.K.) Ltd., Taoyuan Branch**, and found compliance with the requirement of the above standards. The test record, data evaluation & Equipment Under Test (EUT) configurations represented herein are true and accurate accounts of the measurements of the sample's EMC characteristics under the conditions specified in this report.

Prepared by :  , **Date:** Jun. 29, 2016
Ivy Lin / Specialist

Approved by :  , **Date:** Jun. 29, 2016
May Chen / Manager

2 Summary of Test Results

47 CFR FCC Part 15, Subpart C (SECTION 15.247)			
FCC Clause	Test Item	Result	Remarks
15.207	AC Power Conducted Emission	Pass	Meet the requirement of limit. Minimum passing margin is -11.24dB at 0.39609MHz.
15.205 & 209 & 15.247(d)	Radiated Emissions & Band Edge Measurement	Pass	Meet the requirement of limit. Minimum passing margin is -4.1dB at 67.57MHz.
15.247(d)	Antenna Port Emission	Pass	Meet the requirement of limit.
15.247(a)(2)	6dB bandwidth	Pass	Meet the requirement of limit.
15.247(b)	Conducted power	Pass	Meet the requirement of limit.
15.247(e)	Power Spectral Density	Pass	Meet the requirement of limit.
15.203	Antenna Requirement	Pass	Antenna connector is IPEX not a standard connector.

2.1 Measurement Uncertainty

Where relevant, the following measurement uncertainty levels have been estimated for tests performed on the EUT as specified in CISPR 16-4-2:

Measurement	Frequency	Expanded Uncertainty (k=2) (

3 General Information

3.1 General Description of EUT

Product	Access Point
Brand	Aerohive
Test Model	AP550
Status of EUT	Engineering sample
Power Supply Rating	12Vdc from adapter 55Vdc from PoE
Modulation Type	GFSK
Transfer Rate	1Mbps
Operating Frequency	2402 ~ 2480MHz
Number of Channel	40
Channel Spacing	2MHz
Output Power	6.339mW
Antenna Type	Refer to Note
Antenna Connector	IPEX
Accessory Device	N/A
Data Cable Supplied	N/A

Note:

1. There are three radios for the EUT.

Radio	Function
Radio 1	WLAN 2.4G & 5G
Radio 2	WLAN 5G
Radio 3	BT EDR & BT LE

2. The EUT uses following adapter & PoE. (Support unit only)

Adapter	
Brand	DVE
Model	DSA-36PFH-12FUS
Input Power	100-240Vac, 50/60Hz, 1A
Output Power	12.0Vdc / 3.0A
Power Line	1.5m DC cable without core attached on adapter

PoE	
Brand	PowerDsine
Model	PD-9001GR/AT/AC
Input Power	100-240Vac, 50/60Hz, 0.67A
Output Power	55Vdc / 0.6A

3. The following antennas were provided to the EUT.

Radio	Ant. No.	Chain No.	Antenna Gain(dBi) (Including cable loss)	Frequency range	Antenna Type	Connector Type	*Cable Loss(dB)	*Cable Length	
1	Ant. 1	Chain 0	4.00	2.4~2.4835GHz	PIFA	i-pex	0.39	95	
			5.84	5.15~5.25GHz					
			5.92	5.25~5.35GHz					
			5.29	5.47~5.725GHz					
	Ant. 2	Chain 1	5.78	5.725~5.85GHz	PIFA	i-pex	0.41	100	
			3.41	2.4~2.4835GHz					
			5.88	5.15~5.25GHz					
			5.36	5.25~5.35GHz					
	Ant. 3	Chain 2	5.84	5.47~5.725GHz	PIFA	i-pex	0.65	160	
			5.72	5.725~5.85GHz					
			3.77	2.4~2.4835GHz					
			5.64	5.15~5.25GHz					
	Ant. 4	Chain 3	5.49	5.25~5.35GHz	PIFA	i-pex	0.83	203	
			5.31	5.47~5.725GHz					
			5.75	5.725~5.85GHz					
			5.92	5.725~5.85GHz					
2	Ant. 5	Chain 0	5.11	5.15~5.25GHz	PIFA	i-pex	0.4	98	
			5.50	5.25~5.35GHz					
			5.08	5.47~5.725GHz					
			5.40	5.725~5.85GHz					
		Ant. 6	Chain 1	5.55	5.15~5.25GHz	PIFA	i-pex	0.32	78
				5.02	5.25~5.35GHz				
				5.30	5.47~5.725GHz				
				5.94	5.725~5.85GHz				
	Ant. 7	Chain 2	5.62	5.15~5.25GHz	PIFA	i-pex	0.6	148	
			5.78	5.25~5.35GHz					
			5.67	5.47~5.725GHz					
			5.64	5.725~5.85GHz					
	Ant. 8	Chain 3	5.23	5.15~5.25GHz	PIFA	i-pex	0.87	213	
			5.69	5.25~5.35GHz					
			5.75	5.47~5.725GHz					
			5.73	5.725~5.85GHz					
	Ant. 10	Chain 0	4.70	5.15~5.25GHz	Dipole	i-pex	0.23	57	
			5.31	5.25~5.35GHz					
			5.68	5.47~5.725GHz					
			4.74	5.725~5.85GHz					
	Ant. 11	Chain 1	5.15	5.15~5.25GHz	Dipole	i-pex	0.44	107	
			5.25	5.25~5.35GHz					
			4.50	5.47~5.725GHz					
			5.20	5.725~5.85GHz					
	Ant. 12	Chain 2	4.53	5.15~5.25GHz	Dipole	i-pex	0.68	167	
			4.55	5.25~5.35GHz					
			4.42	5.47~5.725GHz					
			5.21	5.725~5.85GHz					
	Ant. 13	Chain 3	4.87	5.15~5.25GHz	Dipole	i-pex	0.93	227	
			4.69	5.25~5.35GHz					
			4.95	5.47~5.725GHz					
			4.41	5.725~5.85GHz					
3	Ant. 9	Chain 0	5.83	2.4~2.4835GHz	Dipole	i-pex	0.36	148	

4. The power setting are listed as below:

	BT LE
CH 0	Default
CH 19	Default
CH 39	Default

5. Spurious emission of the simultaneous operation (Radio 1, 2, & 3) has been evaluated and no non-compliance was found.

3.2 Description of Test Modes

40 channels are provided to this EUT:

Channel	Freq. (MHz)	Channel	Freq. (MHz)	Channel	Freq. (MHz)	Channel	Freq. (MHz)
0	2402	10	2422	20	2442	30	2462
1	2404	11	2424	21	2444	31	2464
2	2406	12	2426	22	2446	32	2466
3	2408	13	2428	23	2448	33	2468
4	2410	14	2430	24	2450	34	2470
5	2412	15	2432	25	2452	35	2472
6	2414	16	2434	26	2454	36	2474
7	2416	17	2436	27	2456	37	2476
8	2418	18	2438	28	2458	38	2478
9	2420	19	2440	29	2460	39	2480

3.2.1 Test Mode Applicability and Tested Channel Detail

EUT CONFIGURE MODE	APPLICABLE TO				DESCRIPTION
	RE \geq 1G	RE<1G	PLC	APCM	
A	√	√	√	√	EUT with PoE mode
B	-	√	√	-	EUT with Adapter mode

Where **RE \geq 1G**: Radiated Emission above 1GHz & Bandedge Measurement
RE<1G: Radiated Emission below 1GHz
PLC: Power Line Conducted Emission
APCM: Antenna Port Conducted Measurement

NOTE:

1. The EUT had been pre-tested on the positioned of each 2 axis. The worst case was found when positioned on Y-plane
2. "-" means no effect.

Radiated Emission Test (Above 1GHz):

- Pre-Scan has been conducted to determine the worst-case mode from all possible combinations between available modulations, data rates and antenna ports (if EUT with antenna diversity architecture).
- Following channel(s) was (were) selected for the final test as listed below.

EUT CONFIGURE MODE	AVAILABLE CHANNEL	TESTED CHANNEL	MODULATION TYPE	DATA RATE (Mbps)
A	0 to 39	0, 19, 39	GFSK	1

Radiated Emission Test (Below 1GHz):

- Pre-Scan has been conducted to determine the worst-case mode from all possible combinations between available modulations, data rates and antenna ports (if EUT with antenna diversity architecture).
- Following channel(s) was (were) selected for the final test as listed below.

EUT CONFIGURE MODE	AVAILABLE CHANNEL	TESTED CHANNEL	MODULATION TYPE	DATA RATE (Mbps)
A, B	0 to 39	19	GFSK	1

Power Line Conducted Emission Test:

- Pre-Scan has been conducted to determine the worst-case mode from all possible combinations between available modulations, data rates and antenna ports (if EUT with antenna diversity architecture).
- Following channel(s) was (were) selected for the final test as listed below.

EUT CONFIGURE MODE	AVAILABLE CHANNEL	TESTED CHANNEL	MODULATION TYPE	DATA RATE (Mbps)
A, B	0 to 39	19	GFSK	1

Antenna Port Conducted Measurement:

- This item includes all test value of each mode, but only includes spectrum plot of worst value of each mode.
- Pre-Scan has been conducted to determine the worst-case mode from all possible combinations between available modulations, data rates and antenna ports (if EUT with antenna diversity architecture).
- Following channel(s) was (were) selected for the final test as listed below.

EUT CONFIGUURE MODE	AVAILABLE CHANNEL	TESTED CHANNEL	MODULATION TYPE	DATA RATE (Mbps)
A	0 to 39	0, 19, 39	GFSK	1

Test Condition:

APPLICABLE TO	ENVIRONMENTAL CONDITIONS	INPUT POWER (SYSTEM)	TESTED BY
RE \geq 1G	23deg. C, 68%RH	120Vac, 60Hz	Robert Cheng
RE $<$ 1G	25deg. C, 65%RH	120Vac, 60Hz	Tim Ho
PLC	24deg. C, 61%RH	120Vac, 60Hz	Jyun Chun Lin
APCM	25deg. C, 60%RH	120Vac, 60Hz	Gary Cheng

3.3 Description of Support Units

The EUT has been tested as an independent unit together with other necessary accessories or support units. The following support units or accessories were used to form a representative test configuration during the tests.

ID	Product	Brand	Model No.	Serial No.	FCC ID	Remarks
A.	Notebook	DELL	E5430	HYV4VY1	FCC DoC Approved	-
B.	iPod	Apple	MC749TA/A	CC4DMFJUDFDM	FCC DoC Approved	-
C.	HUB	ZyXEL	ES-116P	S060H02000215	FCC DoC Approved	-
D.	POE	PowerDsine	PD-9001GR/AT/AC	NA	NA	For test mode A
E.	Adapter	DVE	DSA-36PFH-12FUS	NA	NA	For test mode B

Note:

1. All power cords of the above support units are non-shielded (1.8m).
2. Items A and C acted as communication partners to transfer data.

ID	Descriptions	Qty.	Length (m)	Shielding (Yes/No)	Cores (Qty.)	Remarks
1.	USB cable	1	0.1	Y	0	-
2.	RJ45 cable	1	3	N	0	Cat5e For test mode A
3.	RJ45 cable	1	10	N	0	Cat5e
4.	RJ45 cable	1	10	N	0	Cat5e
5.	Console cable	1	1.5	N	0	-
6.	DC power cable	1	1.5	N	0	Attached on adapter For test mode B

3.3.1 Configuration of System under Test

Test Mode A

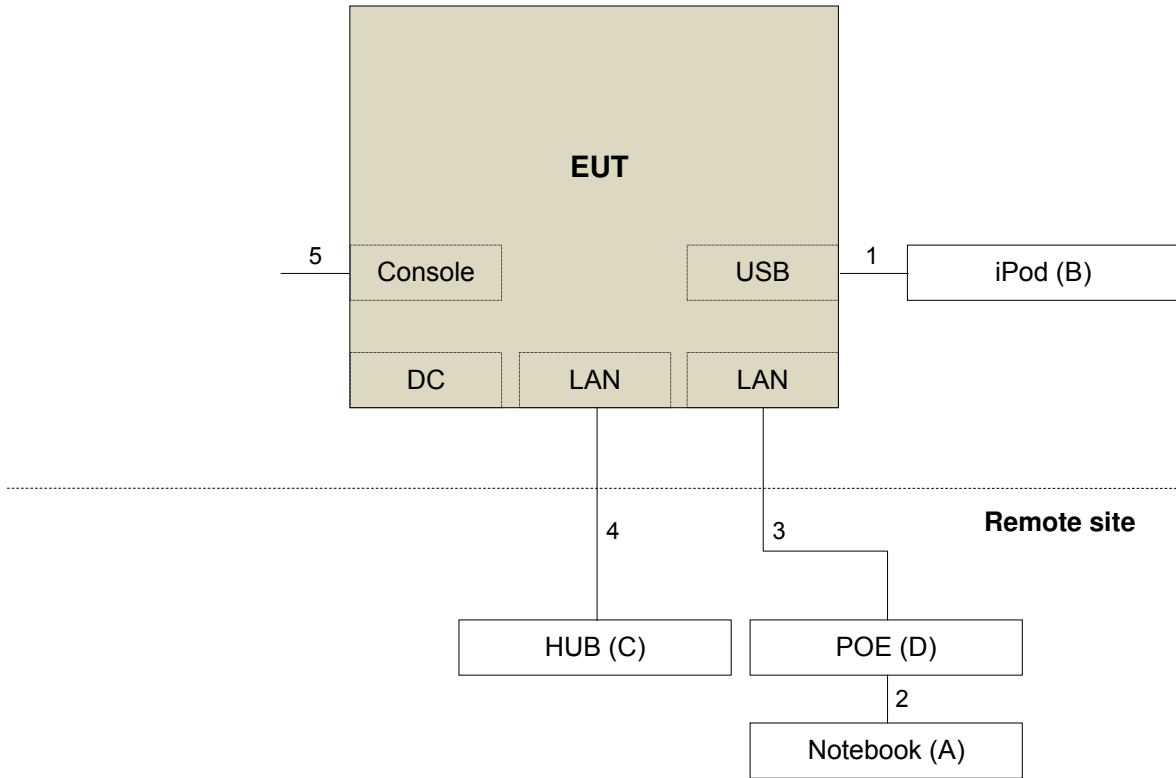

Test Mode B

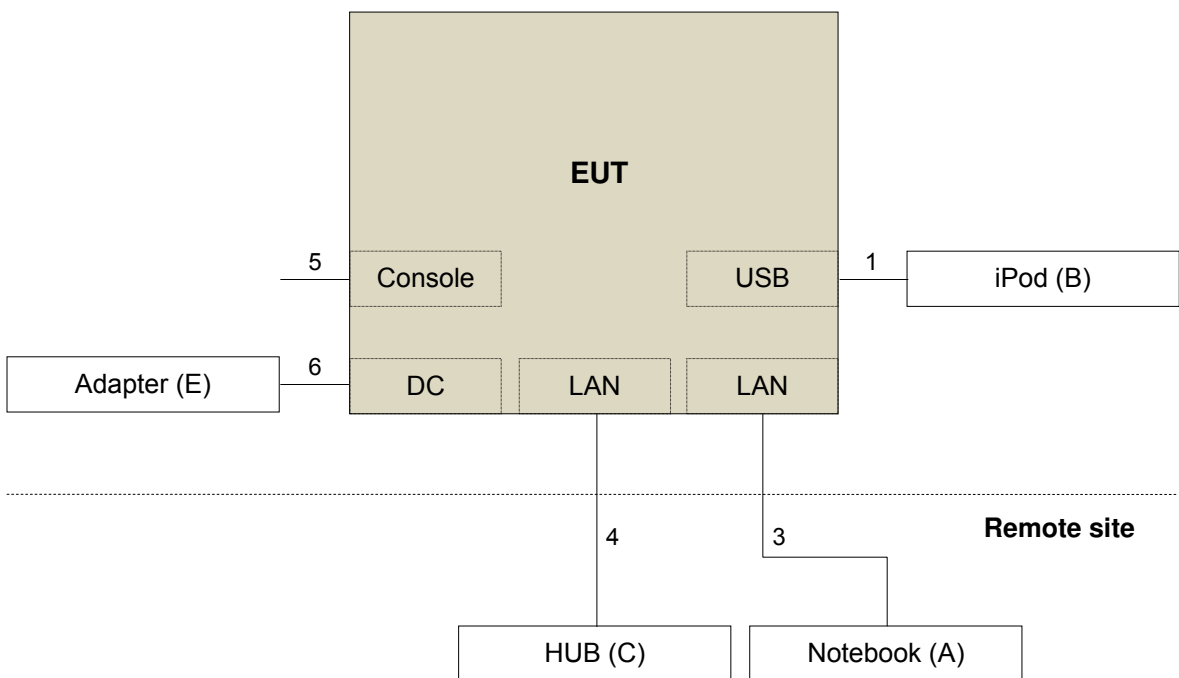

3.4 General Description of Applied Standards

The EUT is a RF Product. According to the specifications of the manufacturer, it must comply with the requirements of the following standards:

FCC Part 15, Subpart C (15.247)
558074 D01 DTS Meas Guidance v03r05
ANSI C63.10-2013

All test items have been performed and recorded as per the above standards.

4 Test Types and Results

4.1 Radiated Emission and Bandedge Measurement

4.1.1 Limits of Radiated Emission and Bandedge Measurement

Radiated emissions which fall in the restricted bands must comply with the radiated emission limits specified as below table. Other emissions shall be at least 20dB below the highest level of the desired power:

Frequencies (MHz)	Field Strength (microvolts/meter)	Measurement Distance (meters)
0.009 ~ 0.490	2400/F(kHz)	300
0.490 ~ 1.705	24000/F(kHz)	30
1.705 ~ 30.0	30	30
30 ~ 88	100	3
88 ~ 216	150	3
216 ~ 960	200	3
Above 960	500	3

Note:

1. The lower limit shall apply at the transition frequencies.
2. Emission level (dBuV/m) = 20 log Emission level (uV/m).
3. For frequencies above 1000MHz, the field strength limits are based on average detector, however, the peak field strength of any emission shall not exceed the maximum permitted average limits, specified above by more than 20dB under any condition of modulation.

4.1.2 Test Instruments

Description & Manufacturer	Model No.	Serial No.	Cal. Date	Cal. Due
Test Receiver Agilent	N9038A	MY50010156	Aug. 12, 2015	Aug. 11, 2016
Pre-Amplifier(*) EMCI	EMC001340	980142	Jan. 20, 2016	Jan. 19, 2018
Loop Antenna(*) Electro-Metrics	EM-6879	264	Dec. 16, 2014	Dec. 15, 2016
RF Cable	NA	LOOPCAB-001 LOOPCAB-002	Jan. 18, 2016	Jan. 17, 2017
Pre-Amplifier Mini-Circuits	ZFL-1000VH2B	AMP-ZFL-05	May 07, 2016	May 06, 2017
Trilog Broadband Antenna SCHWARZBECK	VULB 9168	9168-156	Jan. 04, 2016	Jan. 03, 2017
RF Cable	8D	966-3-1 966-3-2 966-3-3	Apr. 02, 2016	Apr. 01, 2017
Horn_Antenna SCHWARZBECK	BBHA9120-D	9120D-406	Jan. 20, 2016	Jan. 19, 2017
Pre-Amplifier Agilent	8449B	3008A02465	Apr. 05, 2016	Apr. 04, 2017
RF Cable	EMC104-SM-SM-2000 EMC104-SM-SM-5000 EMC104-SM-SM-5000	150317 150321 150322	Mar. 30, 2016	Mar. 29, 2017
Spectrum Analyzer Keysight	N9030A	MY54490520	July 26, 2015	July 25, 2016
Pre-Amplifier EMCI	EMC184045	980143	Jan. 15, 2016	Jan. 14, 2017
Horn_Antenna SCHWARZBECK	BBHA 9170	BBHA9170608	Jan. 08, 2016	Jan. 07, 2017
RF Cable	SUCOFLEX 102	36432/2 36441/2	Jan. 16, 2016	Jan. 15, 2017
Software	ADT_Radiated_V8.7.0 7	NA	NA	NA
Antenna Tower & Turn Table Max-Full	MF-7802	MF780208406	NA	NA
Boresight Antenna Fixture	FBA-01	FBA-SIP01	NA	NA

Note:

1. The calibration interval of the above test instruments is 12 months and the calibrations are traceable to NML/ROC and NIST/USA.
2. The test was performed in 966 Chamber No. 3.
3. The FCC Site Registration No. is 147459
4. The CANADA Site Registration No. is 20331-1
5. Tested Date: May 28 ~ Jun. 02, 2016

Description & Manufacturer	Model No.	Serial No.	Cal. Date	Cal. Due
Spectrum Analyzer R&S	FSP40	100060	May 11, 2016	May 10, 2017
Spectrum Analyzer Agilent	E4446A	MY48250253	Dec. 22, 2015	Dec. 21, 2016
Power meter Anritsu	ML2495A	1014008	May 5, 2016	May 4, 2017
Power sensor Anritsu	MA2411B	0917122	May 5, 2016	May 4, 2017
AC Power Source Extech Electronics	6205	1440452	NA	NA
Temperature & Humidity Chamber Giant Force	GTH-150-40-SP-AR	MAA0812-008	Jan. 15, 2016	Jan. 14, 2017
DC Power Supply Topward	6603D	795558	NA	NA
ESG Vector signal generator Agilent	E4438C	MY45094468/005 506 602 UK6 UNJ	Dec. 01, 2015	Nov. 30, 2016
Mech Switch Absorptive Mini-Circuits	MSP4TA-18+	0140	Mar. 19, 2016	Mar. 18, 2017
FXD ATTEN Mini-Circuits	BW-S3W2+	MN71981	Mar. 19, 2016	Mar. 18, 2017
Software	ADT_RF Test Software V6.6.5.3	NA	NA	NA

Note:

1. The test was performed in Oven room 2.
2. The calibration interval of the above test instruments is 12 months and the calibrations are traceable to NML/ROC and NIST/USA.
3. Tested Date: May 31, 2016

4.1.3 Test Procedures

- a. The EUT was placed on the top of a rotating table 0.8 meters (for below 1GHz) / 1.5 meters (for above 1GHz) above the ground at 3 meter chamber room for test. The table was rotated 360 degrees to determine the position of the highest radiation.
- b. The EUT was set 3 meters away from the interference-receiving antenna, which was mounted on the top of a variable-height antenna tower.
- c. The height of antenna is varied from one meter to four meters above the ground to determine the maximum value of the field strength. Both horizontal and vertical polarizations of the antenna are set to make the measurement.
- d. For each suspected emission, the EUT was arranged to its worst case and then the antenna was tuned to heights from 1 meter to 4 meters and the rotatable table was turned from 0 degrees to 360 degrees to find the maximum reading.
- e. The test-receiver system was set to quasi-peak detect function and specified bandwidth with maximum hold mode when the test frequency is below 1 GHz.
- f. The test-receiver system was set to peak and average detect function and specified bandwidth with maximum hold mode when the test frequency is above 1 GHz. If the peak reading value also meets average limit, measurement with the average detector is unnecessary.

Note:

1. The resolution bandwidth and video bandwidth of test receiver/spectrum analyzer is 120kHz for Quasi-peak detection (QP) at frequency below 1GHz.
2. The resolution bandwidth of test receiver/spectrum analyzer is 1 MHz and the video bandwidth is 3 MHz for Peak detection (PK) at frequency above 1GHz.
3. The resolution bandwidth of test receiver/spectrum analyzer is 1MHz and the video bandwidth is $\geq 1/T$ (Duty cycle < 98%) or 10Hz (Duty cycle $\geq 98\%$) for Average detection (AV) at frequency above 1GHz.
4. All modes of operation were investigated and the worst-case emissions are reported.

4.1.4 Deviation from Test Standard

No deviation.

4.1.5 Test Set Up

<Frequency Range below 1GHz>

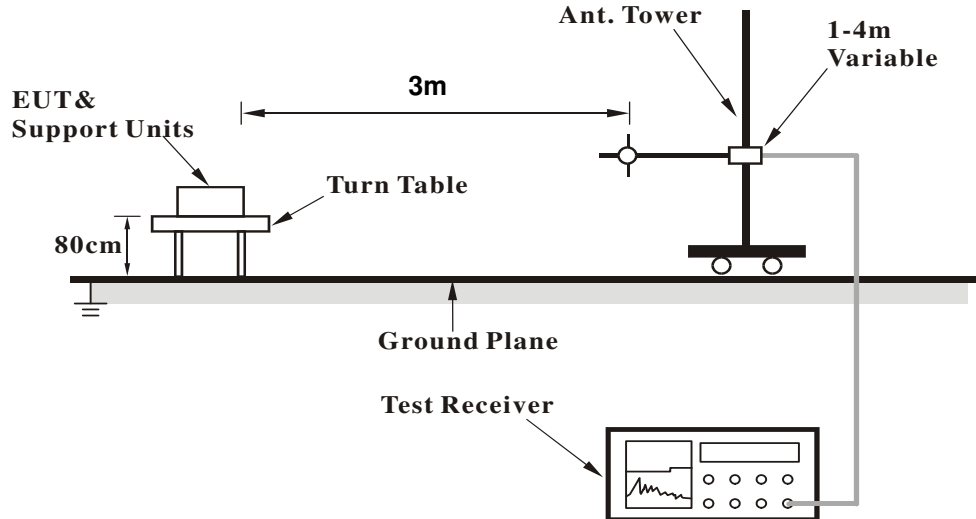

<Frequency Range above 1GHz>

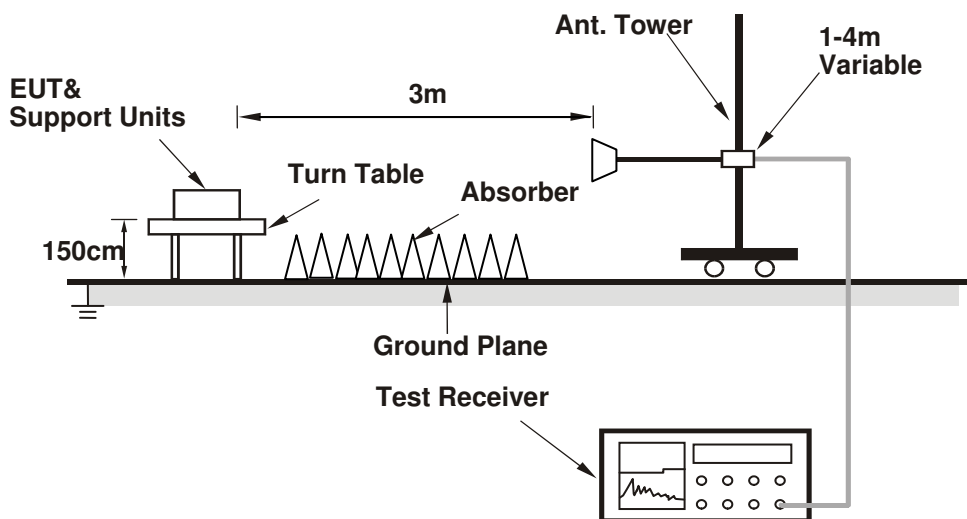

For the actual test configuration, please refer to the attached file (Test Setup Photo).

4.1.6 EUT Operating Conditions

- Placed the EUT on the testing table.
- Prepared notebook to act as communication partner and placed it outside of testing area.
- The communication partner connected with EUT via a RJ45 cable and ran a test program (MTool_REL_2_0_3_2) to enable EUT under transmission condition continuously at specific channel frequency.
- The communication partner sent data to EUT by command "PING".

4.1.7 Test Results

Above 1GHz Data

CHANNEL	TX Channel 0	DETECTOR FUNCTION	Peak (PK)
FREQUENCY RANGE	1GHz ~ 25GHz		Average (AV)

ANTENNA POLARITY & TEST DISTANCE: HORIZONTAL AT 3 M								
NO.	FREQ. (MHz)	EMISSION LEVEL (dBuV/m)	LIMIT (dBuV/m)	MARGIN (dB)	ANTENNA HEIGHT (m)	TABLE ANGLE (Degree)	RAW VALUE (dBuV)	CORRECTION FACTOR (dB/m)
1	2390.00	51.0 PK	74.0	-23.0	3.02 H	175	55.20	-4.20
2	2390.00	45.7 AV	54.0	-8.3	3.02 H	175	49.90	-4.20
3	*2402.00	104.1 PK			3.02 H	175	108.20	-4.10
4	*2402.00	103.3 AV			3.02 H	175	107.40	-4.10
5	4804.00	42.0 PK	74.0	-32.0	2.91 H	152	39.70	2.30
6	4804.00	30.4 AV	54.0	-23.6	2.91 H	152	28.10	2.30
ANTENNA POLARITY & TEST DISTANCE: VERTICAL AT 3 M								
NO.	FREQ. (MHz)	EMISSION LEVEL (dBuV/m)	LIMIT (dBuV/m)	MARGIN (dB)	ANTENNA HEIGHT (m)	TABLE ANGLE (Degree)	RAW VALUE (dBuV)	CORRECTION FACTOR (dB/m)
1	2390.00	50.0 PK	74.0	-24.0	3.19 V	119	54.20	-4.20
2	2390.00	38.5 AV	54.0	-15.5	3.19 V	119	42.70	-4.20
3	*2402.00	98.3 PK			3.12 V	147	102.40	-4.10
4	*2402.00	97.8 AV			3.12 V	147	101.90	-4.10
5	4804.00	40.9 PK	74.0	-33.1	1.66 V	237	38.60	2.30
6	4804.00	30.1 AV	54.0	-23.9	1.66 V	237	27.80	2.30

REMARKS:

1. Emission Level(dBuV/m) = Raw Value(dBuV) + Correction Factor(dB/m)
2. Correction Factor(dB/m) = Antenna Factor(dB/m) + Cable Factor(dB)
3. The other emission levels were very low against the limit.
4. Margin value = Emission Level – Limit value
5. " * ": Fundamental frequency.

CHANNEL	TX Channel 19	DETECTOR FUNCTION	Peak (PK)
FREQUENCY RANGE	1GHz ~ 25GHz		Average (AV)

ANTENNA POLARITY & TEST DISTANCE: HORIZONTAL AT 3 M

NO.	FREQ. (MHz)	EMISSION LEVEL (dBuV/m)	LIMIT (dBuV/m)	MARGIN (dB)	ANTENNA HEIGHT (m)	TABLE ANGLE (Degree)	RAW VALUE (dBuV)	CORRECTION FACTOR (dB/m)
1	*2440.00	105.3 PK			3.31 H	180	109.30	-4.00
2	*2440.00	104.6 AV			3.31 H	180	108.60	-4.00
3	4880.00	41.6 PK	74.0	-32.4	2.80 H	140	39.10	2.50
4	4880.00	30.0 AV	54.0	-24.0	2.80 H	140	27.50	2.50
5	7320.00	47.4 PK	74.0	-26.6	1.46 H	226	38.50	8.90
6	7320.00	35.3 AV	54.0	-18.7	1.46 H	226	26.40	8.90

ANTENNA POLARITY & TEST DISTANCE: VERTICAL AT 3 M

NO.	FREQ. (MHz)	EMISSION LEVEL (dBuV/m)	LIMIT (dBuV/m)	MARGIN (dB)	ANTENNA HEIGHT (m)	TABLE ANGLE (Degree)	RAW VALUE (dBuV)	CORRECTION FACTOR (dB/m)
1	*2440.00	98.2 PK			3.11 V	121	102.20	-4.00
2	*2440.00	97.4 AV			3.11 V	121	101.40	-4.00
3	4880.00	40.6 PK	74.0	-33.4	1.66 V	237	38.10	2.50
4	4880.00	29.9 AV	54.0	-24.1	1.66 V	237	27.40	2.50
5	7320.00	47.8 PK	74.0	-26.2	1.48 V	206	38.90	8.90
6	7320.00	36.0 AV	54.0	-18.0	1.48 V	206	27.10	8.90

REMARKS:

1. Emission Level(dBuV/m) = Raw Value(dBuV) + Correction Factor(dB/m)
2. Correction Factor(dB/m) = Antenna Factor(dB/m) + Cable Factor(dB)
3. The other emission levels were very low against the limit.
4. Margin value = Emission Level – Limit value
5. " * ": Fundamental frequency.

CHANNEL	TX Channel 39	DETECTOR FUNCTION	Peak (PK)
FREQUENCY RANGE	1GHz ~ 25GHz		Average (AV)

ANTENNA POLARITY & TEST DISTANCE: HORIZONTAL AT 3 M								
NO.	FREQ. (MHz)	EMISSION LEVEL (dBuV/m)	LIMIT (dBuV/m)	MARGIN (dB)	ANTENNA HEIGHT (m)	TABLE ANGLE (Degree)	RAW VALUE (dBuV)	CORRECTION FACTOR (dB/m)
1	*2480.00	104.4 PK			1.26 H	194	108.40	-4.00
2	*2480.00	103.9 AV			1.26 H	194	107.90	-4.00
3	2483.50	52.6 PK	74.0	-21.4	1.26 H	194	56.60	-4.00
4	2483.50	41.0 AV	54.0	-13.0	1.26 H	194	45.00	-4.00
5	4960.00	41.8 PK	74.0	-32.2	1.63 H	143	39.30	2.50
6	4960.00	30.2 AV	54.0	-23.8	1.63 H	143	27.70	2.50
7	7440.00	47.5 PK	74.0	-26.5	1.49 H	206	38.00	9.50
8	7440.00	35.7 AV	54.0	-18.3	1.49 H	206	26.20	9.50

ANTENNA POLARITY & TEST DISTANCE: VERTICAL AT 3 M								
NO.	FREQ. (MHz)	EMISSION LEVEL (dBuV/m)	LIMIT (dBuV/m)	MARGIN (dB)	ANTENNA HEIGHT (m)	TABLE ANGLE (Degree)	RAW VALUE (dBuV)	CORRECTION FACTOR (dB/m)
1	*2480.00	98.0 PK			3.16 V	131	102.00	-4.00
2	*2480.00	97.3 AV			3.16 V	131	101.30	-4.00
3	2483.50	49.8 PK	74.0	-24.2	3.16 V	131	53.80	-4.00
4	2483.50	38.2 AV	54.0	-15.8	3.16 V	131	42.20	-4.00
5	4960.00	40.6 PK	74.0	-33.4	1.64 V	221	38.10	2.50
6	4960.00	29.9 AV	54.0	-24.1	1.64 V	221	27.40	2.50
7	7440.00	47.3 PK	74.0	-26.7	1.43 V	205	37.80	9.50
8	7440.00	35.6 AV	54.0	-18.4	1.43 V	205	26.10	9.50

REMARKS:

1. Emission Level(dBuV/m) = Raw Value(dBuV) + Correction Factor(dB/m)
2. Correction Factor(dB/m) = Antenna Factor(dB/m) + Cable Factor(dB)
3. The other emission levels were very low against the limit.
4. Margin value = Emission Level – Limit value
5. " * ": Fundamental frequency.

Below 1GHz worst-case data

CHANNEL	TX Channel 19	DETECTOR FUNCTION	Quasi-Peak (QP)
FREQUENCY RANGE	Below 1GHz		
TEST MODE	A		

ANTENNA POLARITY & TEST DISTANCE: HORIZONTAL AT 3 M

NO.	FREQ. (MHz)	EMISSION LEVEL (dBuV/m)	LIMIT (dBuV/m)	MARGIN (dB)	ANTENNA HEIGHT (m)	TABLE ANGLE (Degree)	RAW VALUE (dBuV)	CORRECTION FACTOR (dB/m)
1	98.11	31.1 QP	43.5	-12.4	2.00 H	246	44.30	-13.20
2	209.56	34.2 QP	43.5	-9.3	1.50 H	229	45.60	-11.40
3	269.39	30.5 QP	46.0	-15.5	1.00 H	108	38.90	-8.40
4	343.68	30.5 QP	46.0	-15.5	1.00 H	314	37.00	-6.50
5	400.18	33.3 QP	46.0	-12.7	1.00 H	205	38.30	-5.00
6	800.08	33.8 QP	46.0	-12.2	1.00 H	106	30.70	3.10

ANTENNA POLARITY & TEST DISTANCE: VERTICAL AT 3 M

NO.	FREQ. (MHz)	EMISSION LEVEL (dBuV/m)	LIMIT (dBuV/m)	MARGIN (dB)	ANTENNA HEIGHT (m)	TABLE ANGLE (Degree)	RAW VALUE (dBuV)	CORRECTION FACTOR (dB/m)
1	37.78	35.7 QP	40.0	-4.3	1.00 V	328	45.00	-9.30
2	72.21	35.1 QP	40.0	-4.9	1.00 V	126	46.10	-11.00
3	157.17	35.1 QP	43.5	-8.4	1.00 V	116	43.40	-8.30
4	302.67	34.5 QP	46.0	-11.5	1.00 V	311	41.80	-7.30
5	400.16	32.1 QP	46.0	-13.9	1.00 V	164	37.10	-5.00
6	644.12	30.2 QP	46.0	-15.8	2.00 V	204	29.50	0.70

REMARKS:

1. Emission Level(dBuV/m) = Raw Value(dBuV) + Correction Factor(dB/m)
2. Correction Factor(dB/m) = Antenna Factor(dB/m) + Cable Factor(dB)
3. The other emission levels were very low against the limit.
4. Margin value = Emission Level – Limit value

CHANNEL	TX Channel 19	DETECTOR FUNCTION	Quasi-Peak (QP)
FREQUENCY RANGE	Below 1GHz		
TEST MODE	B		

ANTENNA POLARITY & TEST DISTANCE: HORIZONTAL AT 3 M

NO.	FREQ. (MHz)	EMISSION LEVEL (dBuV/m)	LIMIT (dBuV/m)	MARGIN (dB)	ANTENNA HEIGHT (m)	TABLE ANGLE (Degree)	RAW VALUE (dBuV)	CORRECTION FACTOR (dB/m)
1	148.57	34.4 QP	43.5	-9.2	2.00 H	154	42.75	-8.40
2	180.63	37.6 QP	43.5	-5.9	1.50 H	274	47.20	-9.59
3	271.62	35.1 QP	46.0	-10.9	1.00 H	360	43.46	-8.36
4	390.14	36.0 QP	46.0	-10.0	1.00 H	341	41.23	-5.25
5	800.61	36.4 QP	46.0	-9.6	1.00 H	264	33.27	3.09
6	900.01	34.5 QP	46.0	-11.5	1.50 H	271	30.27	4.27

ANTENNA POLARITY & TEST DISTANCE: VERTICAL AT 3 M

NO.	FREQ. (MHz)	EMISSION LEVEL (dBuV/m)	LIMIT (dBuV/m)	MARGIN (dB)	ANTENNA HEIGHT (m)	TABLE ANGLE (Degree)	RAW VALUE (dBuV)	CORRECTION FACTOR (dB/m)
1	67.57	35.9 QP	40.0	-4.1	1.00 V	2	45.90	-10.03
2	153.29	36.0 QP	43.5	-7.5	1.50 V	282	44.34	-8.30
3	182.94	35.7 QP	43.5	-7.8	1.00 V	217	45.57	-9.83
4	275.71	34.7 QP	46.0	-11.3	1.00 V	246	42.86	-8.14
5	398.59	35.7 QP	46.0	-10.3	1.00 V	308	40.75	-5.03
6	981.04	34.6 QP	54.0	-19.4	1.00 V	305	29.38	5.18

REMARKS:

1. Emission Level(dBuV/m) = Raw Value(dBuV) + Correction Factor(dB/m)
2. Correction Factor(dB/m) = Antenna Factor(dB/m) + Cable Factor(dB)
3. The other emission levels were very low against the limit.
4. Margin value = Emission Level – Limit value

4.2 Conducted Emission Measurement

4.2.1 Limits of Conducted Emission Measurement

Frequency (MHz)	Conducted Limit (dBuV)	
	Quasi-peak	Average
0.15 - 0.5	66 - 56	56 - 46
0.50 - 5.0	56	46
5.0 - 30.0	60	50

Note: 1.

4.2.4 Deviation from Test Standard

No deviation.

4.2.5 Test Setup

4.2.7 Test Results

Phase	Line (L)	Detector Function	Quasi-Peak (QP) / Average (AV)
Test Mode	A		

No	Freq. [MHz]	Corr. Factor (dB)	Reading Value [dB (uV)]		Emission Level [dB (uV)]		Limit [dB (uV)]		Margin (dB)	
			Q.P.	AV.	Q.P.	AV.	Q.P.	AV.	Q.P.	AV.
			1	0.15000	10.21	33.74	10.55	43.95	20.76	66.00
2	0.18125	10.22	35.00	27.26	45.22	37.48	64.43	54.43	-19.21	-16.95
3	0.22031	10.22	29.97	22.62	40.19	32.84	62.81	52.81	-22.62	-19.97
4	0.39219	10.22	30.52	21.89	40.74	32.11	58.02	48.02	-17.28	-15.91
5	0.83750	10.25	21.13	12.80	31.38	23.05	56.00	46.00	-24.62	-22.95
6	24.00016	11.43	27.16	25.45	38.59	36.88	60.00	50.00	-21.41	-13.12

REMARKS:

1. Q.P. and AV. are abbreviations of quasi-peak and average individually.
2. The emission levels of other frequencies were very low against the limit.
3. Margin value = Emission level - Limit value
4. Correction factor = Insertion loss + Cable loss
5. Emission Level = Correction Factor + Reading Value.

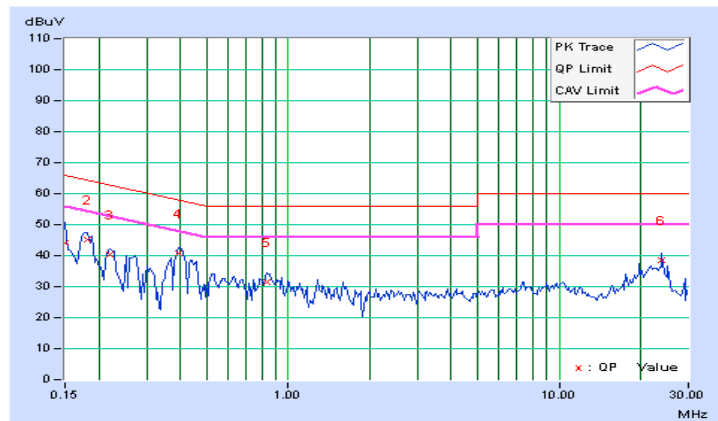

Phase	Neutral (N)	Detector Function	Quasi-Peak (QP) / Average (AV)
Test Mode	A		

No	Freq. [MHz]	Corr. Factor (dB)	Reading Value [dB (uV)]		Emission Level [dB (uV)]		Limit [dB (uV)]		Margin (dB)	
			Q.P.	AV.	Q.P.	AV.	Q.P.	AV.	Q.P.	AV.
			1	0.17734	10.20	35.83	29.16	46.03	39.36	64.61
2	0.22031	10.21	30.81	23.88	41.02	34.09	62.81	52.81	-21.79	-18.72
3	0.39609	10.20	32.10	26.49	42.30	36.69	57.93	47.93	-15.63	-11.24
4	0.84141	10.23	22.41	14.42	32.64	24.65	56.00	46.00	-23.36	-21.35
5	2.75781	10.27	17.24	9.04	27.51	19.31	56.00	46.00	-28.49	-26.69
6	19.67578	11.11	26.28	24.01	37.39	35.12	60.00	50.00	-22.61	-14.88

REMARKS:

1. Q.P. and AV. are abbreviations of quasi-peak and average individually.
2. The emission levels of other frequencies were very low against the limit.
3. Margin value = Emission level - Limit value
4. Correction factor = Insertion loss + Cable loss
5. Emission Level = Correction Factor + Reading Value.

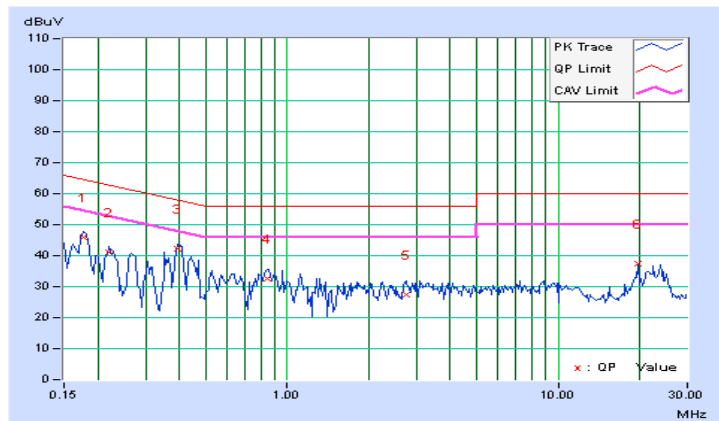

Phase	Line (L)	Detector Function	Quasi-Peak (QP) / Average (AV)
Test Mode	B		

No	Freq. [MHz]	Corr. Factor (dB)	Reading Value [dB (uV)]		Emission Level [dB (uV)]		Limit [dB (uV)]		Margin (dB)	
			Q.P.	AV.	Q.P.	AV.	Q.P.	AV.	Q.P.	AV.
			1	0.15000	10.21	34.85	17.01	45.06	27.22	66.00
2	0.16953	10.21	36.03	24.03	46.24	34.24	64.98	54.98	-18.74	-20.74
3	0.22812	10.22	27.59	16.94	37.81	27.16	62.52	52.52	-24.71	-25.36
4	0.45078	10.22	23.28	17.48	33.50	27.70	56.86	46.86	-23.36	-19.16
5	5.00000	10.35	10.92	5.17	21.27	15.52	56.00	46.00	-34.73	-30.48
6	18.65234	11.27	15.38	8.64	26.65	19.91	60.00	50.00	-33.35	-30.09

REMARKS:

1. Q.P. and AV. are abbreviations of quasi-peak and average individually.
2. The emission levels of other frequencies were very low against the limit.
3. Margin value = Emission level - Limit value
4. Correction factor = Insertion loss + Cable loss
5. Emission Level = Correction Factor + Reading Value.

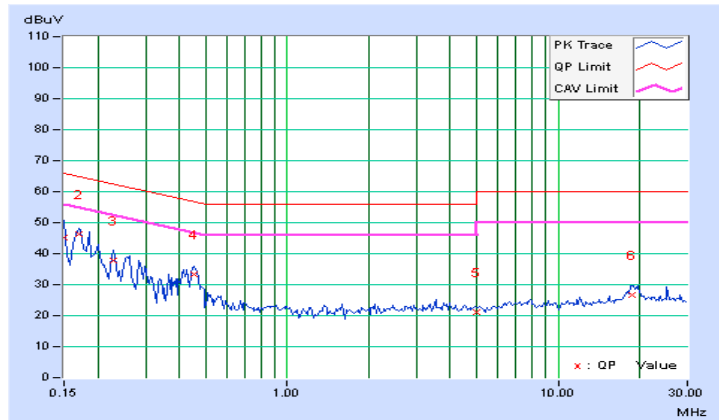

Phase	Neutral (N)	Detector Function	Quasi-Peak (QP) / Average (AV)
Test Mode	B		

No	Freq. [MHz]	Corr. Factor (dB)	Reading Value [dB (uV)]		Emission Level [dB (uV)]		Limit [dB (uV)]		Margin (dB)	
			Q.P.	AV.	Q.P.	AV.	Q.P.	AV.	Q.P.	AV.
			1	0.16953	10.20	36.17	24.04	46.37	34.24	64.98
2	0.19687	10.21	30.46	18.70	40.67	28.91	63.74	53.74	-23.07	-24.83
3	0.22834	10.21	27.25	16.32	37.46	26.53	62.51	52.51	-25.05	-25.98
4	0.45859	10.20	21.90	14.19	32.10	24.39	56.72	46.72	-24.61	-22.32
5	1.34766	10.26	12.60	5.14	22.86	15.40	56.00	46.00	-33.14	-30.60
6	25.23047	11.13	15.93	14.98	27.06	26.11	60.00	50.00	-32.94	-23.89

REMARKS:

1. Q.P. and AV. are abbreviations of quasi-peak and average individually.
2. The emission levels of other frequencies were very low against the limit.
3. Margin value = Emission level - Limit value
4. Correction factor = Insertion loss + Cable loss
5. Emission Level = Correction Factor + Reading Value.

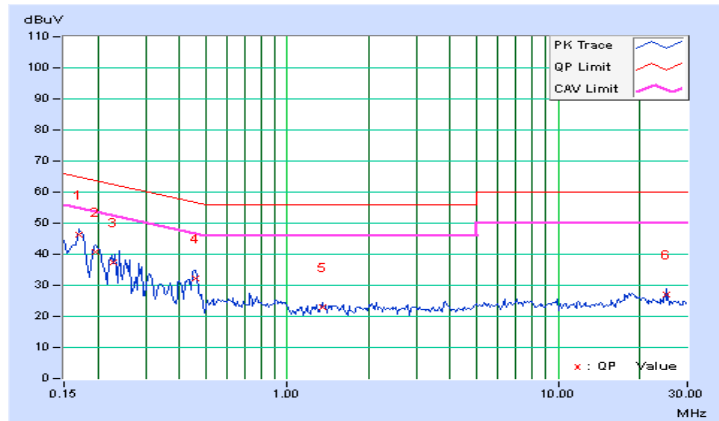

4.3 6dB Bandwidth Measurement

4.3.1 Limits of 6dB Bandwidth Measurement

The minimum of 6dB Bandwidth Measurement is 0.5 MHz.

4.3.2 Test Setup

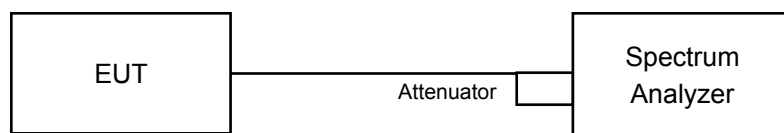

4.3.3 Test Instruments

Refer to section 4.1.2 to get information of above instrument.

4.3.4 Test Procedure

- a. Set resolution bandwidth (RBW) = 100kHz
- b. Set the video bandwidth (VBW) $\geq 3 \times$ RBW, Detector = Peak.
- c. Trace mode = max hold.
- d. Sweep = auto couple.
- e. Measure the maximum width of the emission that is constrained by the frequencies associated with the two amplitude points (upper and lower) that are attenuated by 6 dB relative to the maximum level measured in the fundamental emission

4.3.5 Deviation from Test Standard

No deviation.

4.3.6 EUT Operating Conditions

The software provided by client to enable the EUT under transmission condition continuously at lowest, middle and highest channel frequencies individually.

4.3.7 Test Result

Channel	Frequency (MHz)	6dB Bandwidth (MHz)	Minimum Limit (MHz)	Pass / Fail
0	2402	0.68	0.5	Pass
19	2440	0.70	0.5	Pass
39	2480	0.68	0.5	Pass

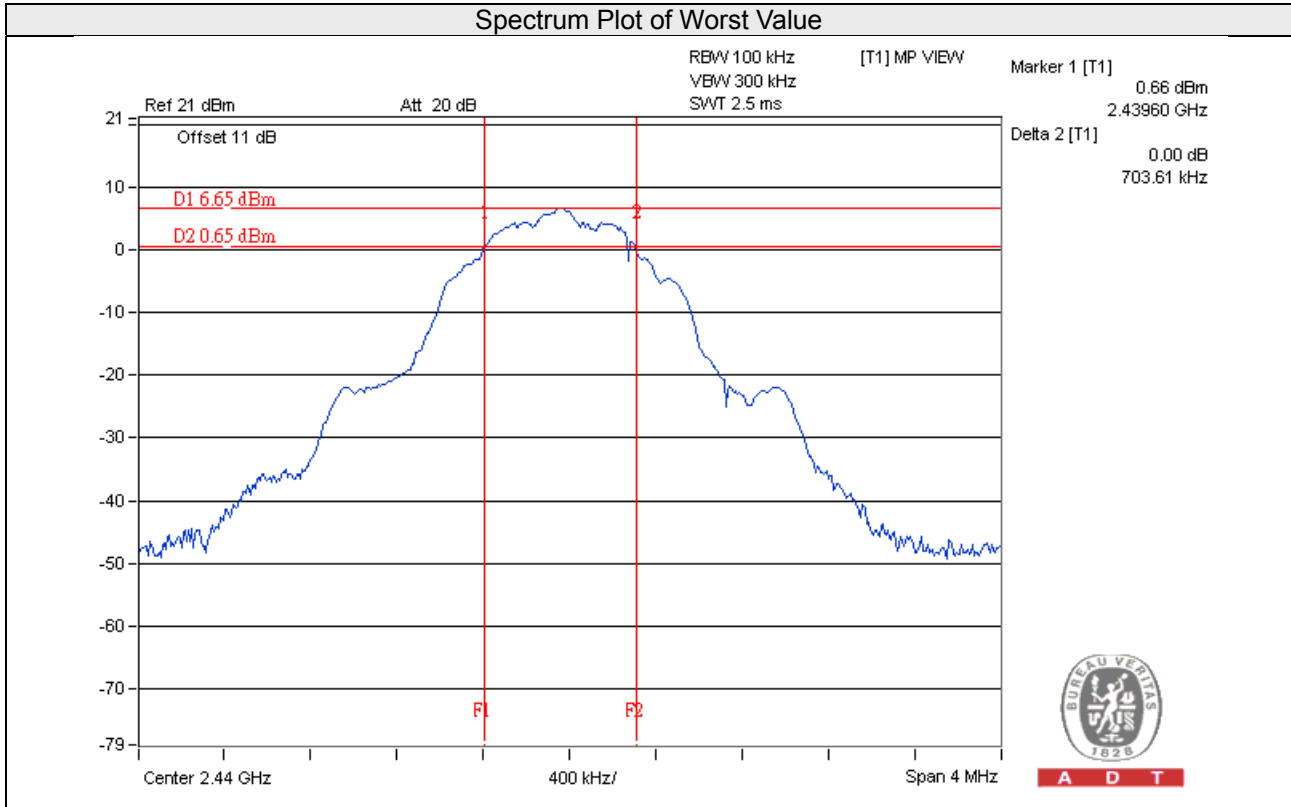

4.4 Conducted Output Power Measurement

4.4.1 Limits of Conducted Output Power Measurement

For systems using digital modulation in the 2400–2483.5 MHz bands: 1 Watt (30dBm)

4.4.2 Test Setup

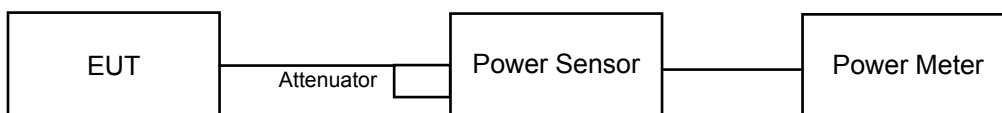

4.4.3 Test Instruments

Refer to section 4.1.2 to get information of above instrument.

4.4.4 Test Procedures

A peak power sensor was used on the output port of the EUT. A power meter was used to read the response of the peak power sensor. Record the power level.

4.4.5 Deviation from Test Standard

No deviation.

4.4.6 EUT Operating Conditions

Same as Item 4.3.6.

4.4.7 Test Results

Channel	Frequency (MHz)	Peak Power (mW)	Peak Power (dBm)	Limit (dBm)	Pass/Fail
0	2402	5.929	7.73	30	Pass
19	2440	6.266	7.97	30	Pass
39	2480	6.339	8.02	30	Pass

4.5 Power Spectral Density Measurement

4.5.1 Limits of Power Spectral Density Measurement

The Maximum of Power Spectral Density Measurement is 8dBm.

4.5.2 Test Setup

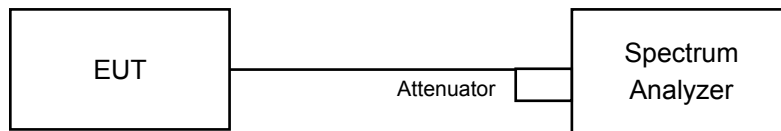

4.5.3 Test Instruments

Refer to section 4.1.2 to get information of above instrument.

4.5.4 Test Procedure

- Set analyzer center frequency to DTS channel center frequency.
- Set the span to 1.5 times the DTS bandwidth.
- Set the RBW to: $3 \text{ kHz} \leq \text{RBW} \leq 100 \text{ kHz}$.
- Set the VBW $\geq 3 \times \text{RBW}$.
- Detector = peak.
- Sweep time = auto couple.
- Trace mode = max hold.
- Allow trace to fully stabilize.
- Use the peak marker function to determine the maximum amplitude level within the RBW.

4.5.5 Deviation from Test Standard

No deviation.

4.5.6 EUT Operating Condition

Same as Item 4.3.6

4.5.7 Test Results

Channel	Freq. (MHz)	PSD (dBm/3kHz)	Limit (dBm/3kHz)	Pass /Fail
0	2402	5.17	8.00	Pass
19	2440	5.77	8.00	Pass
39	2480	5.95	8.00	Pass

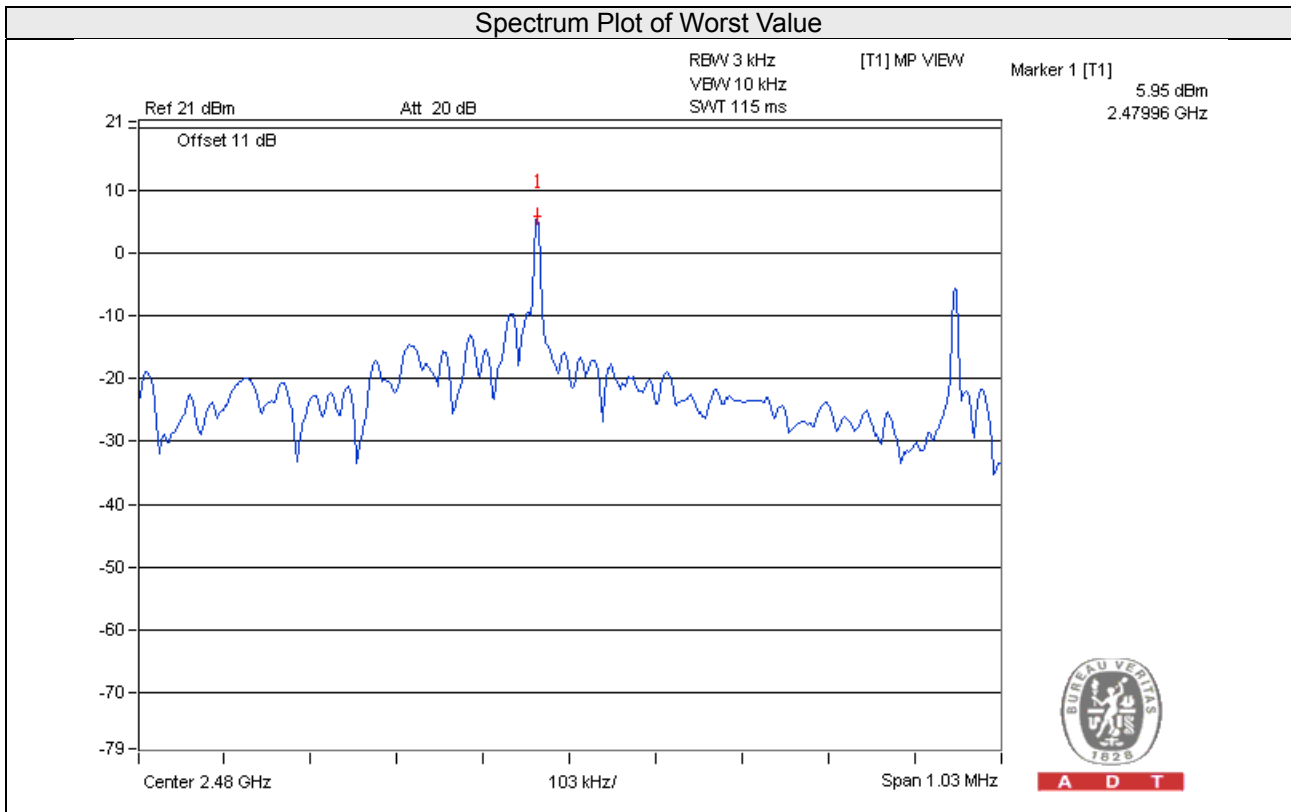

4.6 Conducted Out of Band Emission Measurement

4.6.1 Limits of Conducted Out of Band Emission Measurement

Below 20dB of the highest emission level of operating band (in 100kHz Resolution Bandwidth).

4.6.2 Test Setup

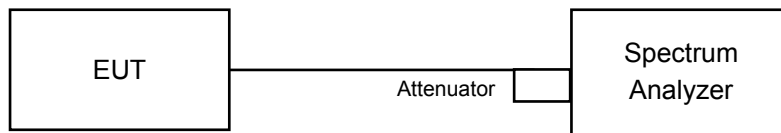

4.6.3 Test Instruments

Refer to section 4.1.2 to get information of above instrument.

4.6.4 Test Procedure

MEASUREMENT PROCEDURE REF

- a. Set the RBW = 100 kHz.
- b. Set the VBW \geq 300 kHz.
- c. Detector = peak.
- d. Sweep time = auto couple.
- e. Trace mode = max hold.
- f. Allow trace to fully stabilize.
- g. Use the peak marker function to determine the maximum power level in any 100 kHz band segment within the fundamental EBW.

MEASUREMENT PROCEDURE OOB

- a. Set RBW = 100 kHz.
- b. Set VBW \geq 300 kHz.
- c. Detector = peak.
- d. Sweep = auto couple.
- e. Trace Mode = max hold.
- f. Allow trace to fully stabilize.
- g. Use the peak marker function to determine the maximum amplitude level.

4.6.5 Deviation from Test Standard

No deviation.

4.6.6 EUT Operating Condition

Same as Item 4.3.6

4.6.7 Test Results

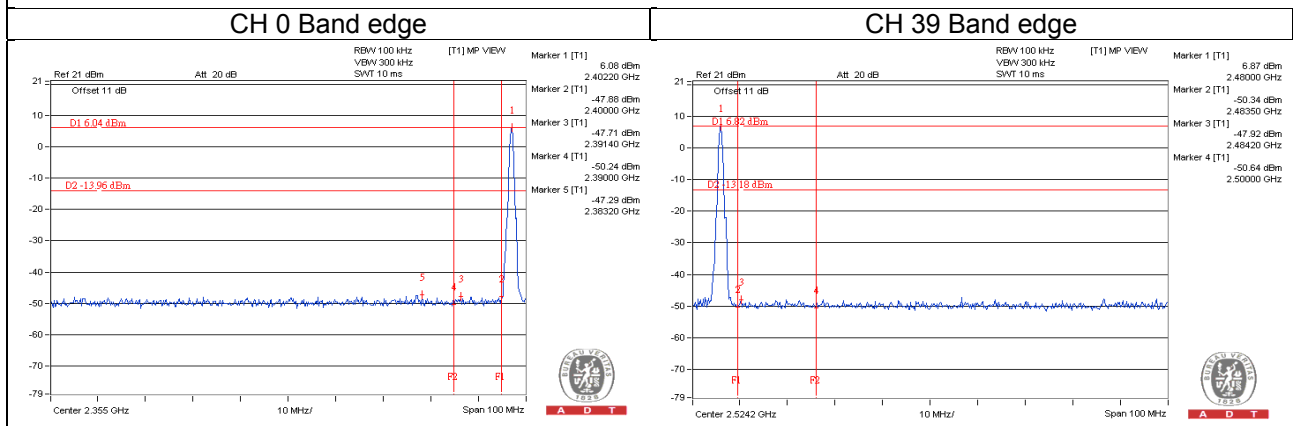
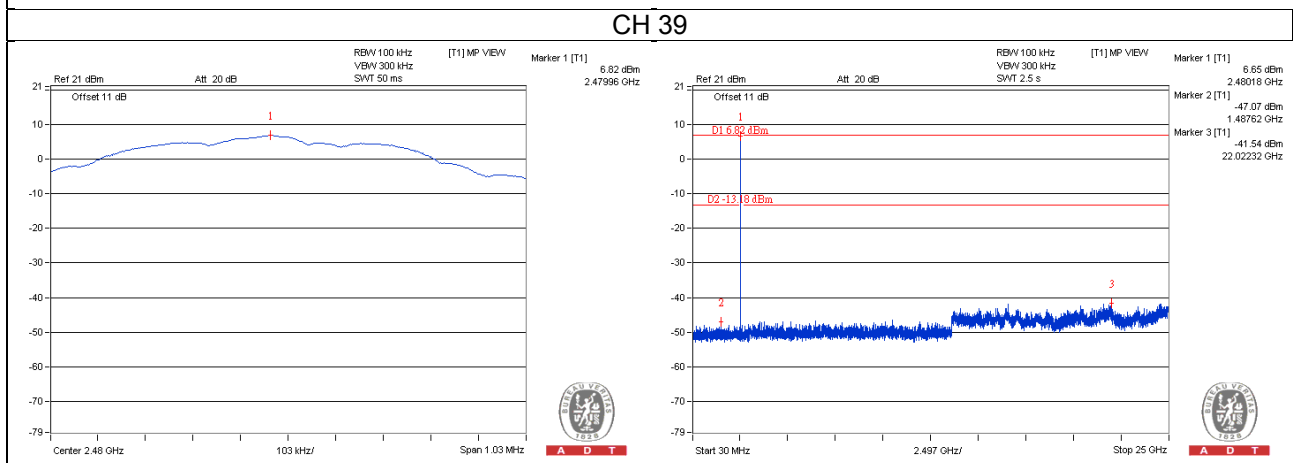
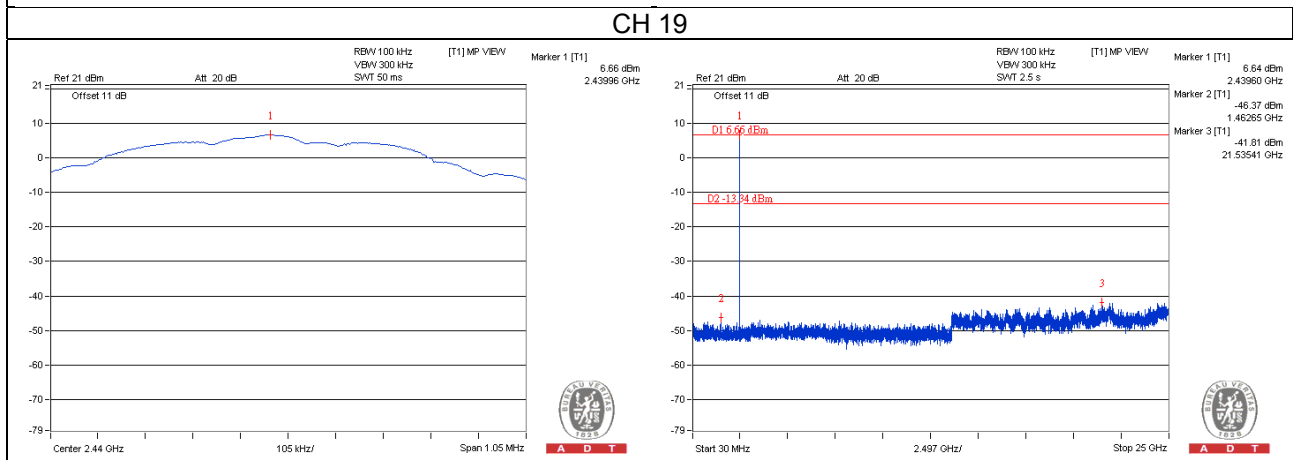
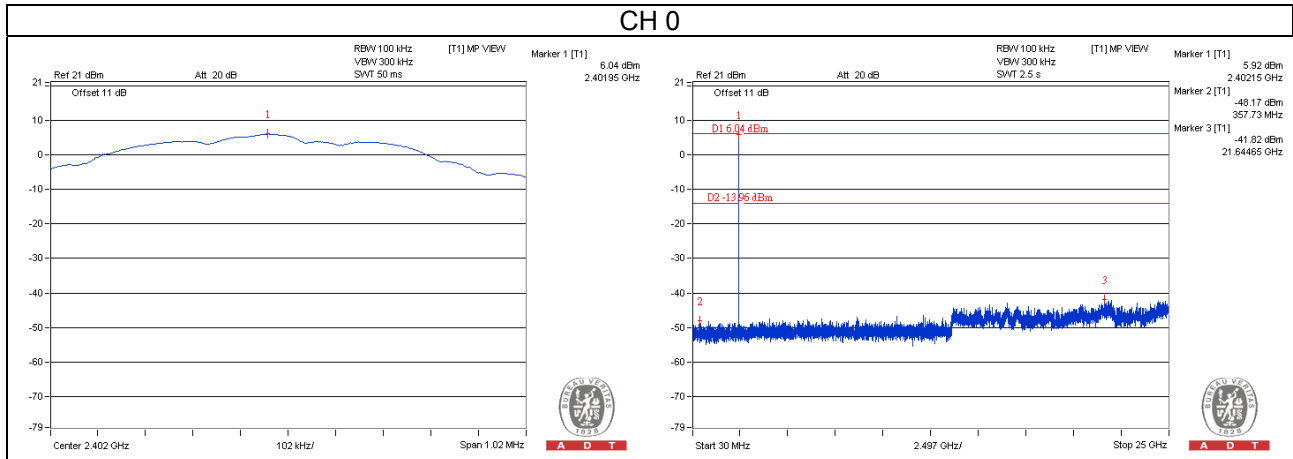

5 Pictures of Test Arrangements

Please refer to the attached file (Test Setup Photo).

Appendix – Information on the Testing Laboratories

We, Bureau Veritas Consumer Products Services (H.K.) Ltd., Taoyuan Branch, were founded in 1988 to provide our best service in EMC, Radio, Telecom and Safety consultation. Our laboratories are accredited and approved according to ISO/IEC 17025.

If you have any comments, please feel free to contact us at the following:

Linko EMC/RF Lab

Tel: 886-2-26052180

Fax: 886-2-26051924

Hsin Chu EMC/RF/Telecom Lab

Tel: 886-3-6668565

Fax: 886-3-6668323

Hwa Ya EMC/RF/Safety Lab

Tel: 886-3-3183232

Fax: 886-3-3270892

Email: service.adt@tw.bureauveritas.com

Web Site: www.bureauveritas-adt.com

The address and road map of all our labs can be found in our web site also.

--- END ---