

## FCC Test Report (WLAN)

**Report No.:** RF151116E02

**FCC ID:** WBV-AP250

**Test Model:** AP250

**Received Date:** Nov. 16, 2015

**Test Date:** Dec. 15, 2015 to Mar. 11, 2016

**Issued Date:** Mar. 29, 2016

**Applicant:** Aerohive Networks Inc.

**Address:** 330 Gibraltar Drive, Sunnyvale, CA 94089, USA

**Issued By:** Bureau Veritas Consumer Products Services (H.K.) Ltd., Taoyuan Branch  
Hsin Chu Laboratory

**Lab Address:** E-2, No.1, Li Hsin 1st Road, Hsinchu Science Park, Hsinchu City 300,  
Taiwan R.O.C.

**Test Location (1):** E-2, No.1, Li Hsin 1st Road, Hsinchu Science Park, Hsinchu City 300,  
Taiwan R.O.C.

**Test Location (2):** No. 49, Ln. 206, Wende Rd., Shangshan Tsuen, Chiung Lin Hsiang, Hsin  
Chu Hsien 307, Taiwan R.O.C.



This report is for your exclusive use. Any copying or replication of this report to or for any other person or entity, or use of our name or trademark, is permitted only with our prior written permission. This report sets forth our findings solely with respect to the test samples identified herein. The results set forth in this report are not indicative or representative of the quality or characteristics of the lot from which a test sample was taken or any similar or identical product specifically and expressly noted. Our report includes all of the tests requested by you and the results thereof based upon the information that you provided to us. You have 60 days from date of issuance of this report to notify us of any material error or omission caused by our negligence, provided, however, that such notice shall be in writing and shall specifically address the issue you wish to raise. A failure to raise such issue within the prescribed time shall constitute your unqualified acceptance of the completeness of this report, the tests conducted and the correctness of the report contents. Unless specific mention, the uncertainty of measurement has been explicitly taken into account to declare the compliance or non-compliance to the specification. The report must not be used by the client to claim product certification, approval, or endorsement by TAF or any government agencies.

## Table of Contents

<b>Release Control Record</b> .....	<b>4</b>
<b>1 Certificate of Conformity</b> .....	<b>5</b>
<b>2 Summary of Test Results</b> .....	<b>6</b>
2.1 Measurement Uncertainty.....	6
2.2 Modification Record.....	6
<b>3 General Information</b> .....	<b>7</b>
3.1 General Description of EUT (WLAN).....	7
3.2 Description of Test Modes.....	11
3.2.1 Test Mode Applicability and Tested Channel Detail.....	12
3.3 Duty Cycle of Test Signal.....	15
3.4 Description of Support Units.....	16
3.4.1 Configuration of System under Test.....	17
3.5 General Description of Applied Standards.....	19
<b>4 Test Types and Results</b> .....	<b>20</b>
4.1 Radiated Emission and Bandedge Measurement.....	20
4.1.1 Limits of Radiated Emission and Bandedge Measurement.....	20
4.1.2 Test Instruments.....	21
4.1.3 Test Procedures.....	23
4.1.4 Deviation from Test Standard.....	23
4.1.5 Test Setup.....	24
4.1.6 EUT Operating Conditions.....	24
4.1.7 Test Results (Mode 1).....	25
4.1.8 Test Results (Mode 2).....	53
4.2 Conducted Emission Measurement.....	54
4.2.1 Limits of Conducted Emission Measurement.....	54
4.2.2 Test Instruments.....	54
4.2.3 Test Procedures.....	55
4.2.4 Deviation from Test Standard.....	55
4.2.5 Test Setup.....	55
4.2.6 EUT Operating Conditions.....	55
4.2.7 Test Results (Mode 1).....	56
4.2.8 Test Results (Mode 2).....	58
4.3 6dB Bandwidth Measurement.....	60
4.3.1 Limits of 6dB Bandwidth Measurement.....	60
4.3.2 Test Setup.....	60
4.3.3 Test Instruments.....	60
4.3.4 Test Procedure.....	60
4.3.5 Deviation from Test Standard.....	60
4.3.6 EUT Operating Conditions.....	60
4.3.7 Test Result.....	61
4.4 Conducted Output Power Measurement.....	67
4.4.1 Limits of Conducted Output Power Measurement.....	67
4.4.2 Test Setup.....	67
4.4.3 Test Instruments.....	67
4.4.4 Test Procedures.....	67
4.4.5 Deviation from Test Standard.....	67
4.4.6 EUT Operating Conditions.....	67
4.4.7 Test Results.....	68
4.5 Power Spectral Density Measurement.....	71
4.5.1 Limits of Power Spectral Density Measurement.....	71
4.5.2 Test Setup.....	71
4.5.3 Test Instruments.....	71
4.5.4 Test Procedure.....	71



4.5.5	Deviation from Test Standard .....	71
4.5.6	EUT Operating Condition .....	71
4.5.7	Test Results .....	72
4.6	Conducted Out of Band Emission Measurement.....	79
4.6.1	Limits of Conducted Out of Band Emission Measurement .....	79
4.6.2	Test Setup.....	79
4.6.3	Test Instruments .....	79
4.6.4	Test Procedure .....	79
4.6.5	Deviation from Test Standard .....	79
4.6.6	EUT Operating Condition .....	79
4.6.7	Test Results .....	80
<b>5</b>	<b>Pictures of Test Arrangements.....</b>	<b>99</b>
	<b>Appendix – Information on the Testing Laboratories .....</b>	<b>100</b>



A D T

### Release Control Record

Issue No.	Description	Date Issued
RF151116E02	Original release.	Mar. 29, 2016



**1 Certificate of Conformity**

**Product:** Access Point

**Brand:** Aerohive

**Test Model:** AP250

**Sample Status:** Engineer Sample (DVT2)

**Applicant:** Aerohive Networks Inc.

**Test Date:** Dec. 15, 2015 to Mar. 11, 2016

**Standards:** 47 CFR FCC Part 15, Subpart C (Section 15.247)  
ANSI C63.10: 2013

The above equipment has been tested by **Bureau Veritas Consumer Products Services (H.K.) Ltd., Taoyuan Branch**, and found compliance with the requirement of the above standards. The test record, data evaluation & Equipment Under Test (EUT) configurations represented herein are true and accurate accounts of the measurements of the sample's EMC characteristics under the conditions specified in this report.

**Prepared by :** Wendy Wu , **Date:** Mar. 29, 2016  
Wendy Wu / Specialist

**Approved by :** May Chen , **Date:** Mar. 29, 2016  
May Chen / Manager

## 2 Summary of Test Results

47 CFR FCC Part 15, Subpart C (SECTION 15.247)			
FCC Clause	Test Item	Result	Remarks
15.207	AC Power Conducted Emission	PASS	Meet the requirement of limit. Minimum passing margin is -4.97dB at 18.24219MHz.
15.205 / 15.209 / 15.247(d)	Radiated Emissions and Band Edge Measurement	PASS	Meet the requirement of limit. Minimum passing margin is -0.1dB at 4874.00MHz, 2390.00MHz, 2483.50MHz and 4924.00MHz.
15.247(d)	Antenna Port Emission	PASS	Meet the requirement of limit.
15.247(a)(2)	6dB bandwidth	PASS	Meet the requirement of limit.
15.247(b)	Conducted power	PASS	Meet the requirement of limit.
15.247(e)	Power Spectral Density	PASS	Meet the requirement of limit.
15.203	Antenna Requirement	PASS	Antenna connector is i-pex (MHF) not a standard connector.

### 2.1 Measurement Uncertainty

Where relevant, the following measurement uncertainty levels have been estimated for tests performed on the EUT as specified in CISPR 16-4-2:

Measurement	Frequency	Expanded Uncertainty (k=2) (±)
Conducted Emissions at mains ports	150kHz ~ 30MHz	2.86 dB
Radiated Emissions up to 1 GHz	30MHz ~ 1GHz	5.19 dB
Radiated Emissions above 1 GHz	1GHz ~ 6GHz	3.43 dB
	6GHz ~ 18GHz	3.49 dB
	18GHz ~ 40GHz	4.11 dB

### 2.2 Modification Record

There were no modifications required for compliance.

### 3 General Information

#### 3.1 General Description of EUT (WLAN)

Product	Access Point
Brand	Aerohive
Test Model	AP250
Status of EUT	Engineer Sample (DVT2)
Power Supply Rating	48Vdc or 55Vdc from POE
Modulation Type	CCK, DQPSK, DBPSK for DSSS 64QAM, 16QAM, QPSK, BPSK for OFDM 256QAM for OFDM in 11ac mode and VHT20 mode of 2.4GHz band.
Modulation Technology	DSSS, OFDM
Transfer Rate	802.11b: up to 11Mbps 802.11a / g: up to 54Mbps 802.11n: up to 450Mbps 802.11ac: up to 1300Mbps
Operating Frequency	<b>2.4GHz:</b> 2.412GHz ~ 2.462GHz <b>5GHz:</b> 5.18GHz ~ 5.24GHz, 5.745GHz ~ 5.825GHz
Number of Channel	<b>2.4GHz:</b> 11 for 802.11b, 802.11g, 802.11n (HT20), VHT20 <b>5GHz:</b> 9 for 802.11a, 802.11n (HT20), 802.11ac (VHT20) 4 for 802.11n (HT40), 802.11ac (VHT40) 2 for 802.11ac (VHT80)
Output Power	<b>Radio 1</b> <b>2.4GHz:</b> <b>3TX</b> <b>CDD Mode:</b> 580.036mW <b>Beamforming Mode:</b> 496.83 mW <b>2TX</b> <b>CDD Mode:</b> 386.394mW <b>Beamforming Mode:</b> 382.852mW <b>1TX</b> 802.11g: 193.642mW

Output Power	<b>5GHz (5.18 ~ 5.24GHz):</b> <b>3TX</b> <b>CDD Mode:</b> 248.924mW <b>Beamforming Mode:</b> 248.924mW <b>2TX</b> <b>Chain 0+2</b> <b>CDD Mode:</b> 212.439mW <b>Beamforming Mode:</b> 212.439mW <b>1TX</b> <b>Chain 0</b> 143.219mW <b>5GHz (5.745 ~ 5.825GHz):</b> <b>3TX</b> <b>CDD Mode:</b> 232.391mW <b>Beamforming Mode:</b> 232.391mW <b>2TX</b> <b>Chain 1+2</b> <b>CDD Mode:</b> 192.853mW <b>Beamforming Mode:</b> 187.739mW <b>1TX</b> <b>Chain 2</b> 99.312mW
	<b>Radio 2</b> <b>5GHz (5.18 ~ 5.24GHz):</b> <b>3TX</b> <b>CDD Mode:</b> 346.127mW <b>Beamforming Mode:</b> 346.127mW <b>2TX</b> <b>Chain 0+1</b> <b>CDD Mode:</b> 245.068mW <b>Beamforming Mode:</b> 245.068mW <b>1TX</b> <b>Chain 0</b> 152.405mW <b>5GHz (5.745 ~ 5.825GHz):</b> <b>3TX</b> <b>CDD Mode:</b> 383.167mW <b>Beamforming Mode:</b> 378.929mW <b>2TX</b> <b>Chain 0+1</b> <b>CDD Mode:</b> 235.596mW <b>Beamforming Mode:</b> 233.718mW <b>1TX</b> <b>Chain 0</b> 123.31mW
Antenna Type	Refer to Note
Antenna Connector	Refer to Note
Accessory Device	NA
Data Cable Supplied	NA

Note:

1. The EUT has three radio transceivers, radio 1 is WLAN technologies for dual band (2.4GHz & 5GHz), radio 2 is WLAN technologies for single band (2.4GHz), and radio 3 is Bluetooth low energy (BLE) technology only.
2. The emission of the simultaneous operation (WLAN & BT) has been evaluated and no non-compliance was found.



3. The antennas provided to the EUT, please refer to the following table:

<b>Radio 1</b>									
<b>WLAN - 2.4GHz + 5GHz</b>									
Antenna NO.	Transmitter Circuit	Brand	Model No.	Ant. Gain (dBi) Including cable loss	Frequency Range (GHz)	Antenna Type	Connector Type	Cable Loss(dB)	Cable Length
ANT1	Chain (0)	N/A	XKAA-N08	5.14	2.4~2.4835	PIFA	i-pex (MHF)	0.21	54mm
				5.41	5.15~5.25				
				5.02	5.25~5.35				
				5.25	5.47~5.725				
ANT2	Chain (1)	N/A	XKAA-N08	5.13	5.725~5.85	PIFA	i-pex (MHF)	0.19	49mm
				4.28	2.4~2.4835				
				4.82	5.15~5.25				
				5.16	5.25~5.35				
ANT3	Chain (2)	N/A	XKAA-N08	5.14	5.47~5.725	PIFA	i-pex (MHF)	0.39	101mm
				5.31	5.725~5.85				
				2.80	2.4~2.4835				
				5.25	5.15~5.25				
ANT5	Chain (0)	N/A	XKAA-N08	5.46	5.25~5.35	V-pol PIFA	i-pex (MHF)	0.82	213mm
				5.37	5.47~5.725				
				5.65	5.725~5.85				
				5.3	5.725~5.85				
ANT6	Chain (1)	N/A	XKAA-N08	5.54	5.15~5.25	V-pol PIFA	i-pex (MHF)	0.25	66mm
				5.72	5.25~5.35				
				5.56	5.47~5.725				
				5.1	5.725~5.85				
ANT7	Chain (1)	N/A	XKAA-N08	5.24	5.15~5.25	H-pol Dipole	i-pex (MHF)	0.58	150mm
				6.38	5.25~5.35				
				5.36	5.47~5.725				
				5.27	5.725~5.85				
ANT8	Chain (2)	N/A	XKAA-N08	4.88	5.15~5.25	H-pol Dipole	i-pex (MHF)	0.77	201mm
				4.27	5.25~5.35				
				4.84	5.47~5.725				
				5.19	5.725~5.85				
ANT9	Chain (2)	N/A	XKAA-N08	4.41	5.15~5.25	H-pol Dipole	i-pex (MHF)	0.73	190mm
				4.55	5.25~5.35				
				4.79	5.47~5.725				
				4.87	5.725~5.85				
<b>Radio 3</b>									
<b>Bluetooth - 2.4GHz</b>									
ANT4	Chain (0)	N/A	XKAA-N08	4.24	2.4~2.4835	Dipole	i-pex (MHF)	0.62	160mm

4. The EUT power needs to be supplied from POE(only for test), the information is as below table:

No.	Brand	Model No.	Spec.
1	PowerDsine	PD-9001GR/AT/AC	Input: 100-240V, 0.67A, 50/60Hz Output: 55V, 0.6A
2	PowerDsine	PD-3501G/AC	Input: 100-240V, 0.43A, 50/60Hz Output: 48V, 0.35A

For radiated emission above 1GHz test, the EUT was pre-tested with POE 1 & 2, the worst case was found in POE 1. Therefore only the test data of the POE 1 was recorded in this report.

5. The EUT incorporates a MIMO function.

<b>Radio 1</b>			
<b>WLAN – 2.4GHz</b>			
<b>MODULATION MODE</b>	<b>DATA RATE (MCS)</b>	<b>TX &amp; RX CONFIGURATION</b>	
<b>802.11b</b>	1 ~ 11Mbps	3TX	3RX
<b>802.11g</b>	6 ~ 54Mbps	3TX	3RX
<b>802.11n (HT20)</b>	MCS 0~7	3TX	3RX
	MCS 8~15	3TX	3RX
	MCS 16~23	3TX	3RX
<b>VHT20</b>	MCS0~8 Nss=1	3TX	3RX
	MCS0~8 Nss=2	3TX	3RX
	MCS0~9 Nss=3	3TX	3RX
<b>Radio 1 and Radio 2</b>			
<b>WLAN – 5GHz</b>			
<b>MODULATION MODE</b>	<b>DATA RATE (MCS)</b>	<b>TX &amp; RX CONFIGURATION</b>	
<b>802.11a</b>	6 ~ 54Mbps	3TX	3RX
<b>802.11n (HT20)</b>	MCS 0~7	3TX	3RX
	MCS 8~15	3TX	3RX
	MCS 16~23	3TX	3RX
<b>802.11n (HT40)</b>	MCS 0~7	3TX	3RX
	MCS 8~15	3TX	3RX
	MCS 16~23	3TX	3RX
<b>802.11ac (VHT20)</b>	MCS0~8 Nss=1	3TX	3RX
	MCS0~8 Nss=2	3TX	3RX
	MCS0~9 Nss=3	3TX	3RX
<b>802.11ac (VHT40)</b>	MCS0~9 Nss=1	3TX	3RX
	MCS0~9 Nss=2	3TX	3RX
	MCS0~9 Nss=3	3TX	3RX
<b>802.11ac (VHT80)</b>	MCS0~9 Nss=1	3TX	3RX
	MCS0~9 Nss=2	3TX	3RX
	MCS0~8 Nss=3	3TX	3RX

Note. : 1. The modulation and bandwidth are similar for 802.11n mode for 20MHz (40MHz) and 802.11ac mode for 20MHz (40MHz), therefore investigated worst case to representative mode in test report. (Final test mode refer section 3.2.1)  
2. All of modulation mode support beamforming function except 802.11a/b/g modulation.

6. The above EUT information is declared by manufacturer and for more detailed features description, please refer to the manufacturer's specifications or user's manual.

### 3.2 Description of Test Modes

11 channels are provided for 802.11b, 802.11g and 802.11n (HT20), VHT20:

Channel	Frequency	Channel	Frequency
1	2412MHz	7	2442MHz
2	2417MHz	8	2447MHz
3	2422MHz	9	2452MHz
4	2427MHz	10	2457MHz
5	2432MHz	11	2462MHz
6	2437MHz		

### 3.2.1 Test Mode Applicability and Tested Channel Detail

EUT CONFIGURE MODE	APPLICABLE TO				DESCRIPTION
	RE $\geq$ 1G	RE $<$ 1G	PLC	APCM	
1	√	√	√	√	For Radio 1 with POE1(PD-9001GR)
2	-	√	√	-	For Radio 1 with POE2(PD-3501G)

Where **RE $\geq$ 1G**: Radiated Emission above 1GHz & Bandedge Measurement  
**RE $<$ 1G**: Radiated Emission below 1GHz  
**PLC**: Power Line Conducted Emission  
**APCM**: Antenna Port Conducted Measurement

**NOTE:** The EUT had been pre-tested on the positioned of each 2 axis. The worst case was found when positioned on Y-plane (for below 1GHz) and X-plane (for above 1GHz).

**NOTE:** “-” means no effect.

#### **Radiated Emission Test (Above 1GHz):**

- Pre-Scan has been conducted to determine the worst-case mode from all possible combinations between available modulations, data rates and antenna ports (if EUT with antenna diversity architecture).
- Following channel(s) was (were) selected for the final test as listed below.

<b>For Radio 1 : 3TX Configuration</b>						
MODE	ANTENNA COMBINATION	AVAILABLE CHANNEL	TESTED CHANNEL	MODULATION TECHNOLOGY	MODULATION TYPE	DATA RATE (Mbps)
802.11b	CDD ANT1, ANT2, ANT3	1 to 11	1, 6, 11	DSSS	DBPSK	1
802.11g		1 to 11	1, 6, 11	OFDM	BPSK	6
802.11n (HT20)		1 to 11	1, 6, 11	OFDM	BPSK	6.5
<b>For Radio 1 : 2TX Configuration</b>						
MODE	ANTENNA COMBINATION	AVAILABLE CHANNEL	TESTED CHANNEL	MODULATION TECHNOLOGY	MODULATION TYPE	DATA RATE (Mbps)
802.11b	CDD ANT1, ANT2	1 to 11	1, 6, 11	DSSS	DBPSK	1
802.11g		1 to 11	1, 6, 11	OFDM	BPSK	6
802.11n (HT20)		1 to 11	1, 6, 11	OFDM	BPSK	6.5
<b>For Radio 1 : 1TX Configuration</b>						
MODE	ANTENNA COMBINATION	AVAILABLE CHANNEL	TESTED CHANNEL	MODULATION TECHNOLOGY	MODULATION TYPE	DATA RATE (Mbps)
802.11b	ANT1	1 to 11	1, 6, 11	DSSS	DBPSK	1
802.11g		1 to 11	1, 6, 11	OFDM	BPSK	6
802.11n(HT20)		1 to 11	1, 6, 11	OFDM	BPSK	6.5

**Radiated Emission Test (Below 1GHz):**

- Pre-Scan has been conducted to determine the worst-case mode from all possible combinations between available modulations, data rates and antenna ports (if EUT with antenna diversity architecture).
- Following channel(s) was (were) selected for the final test as listed below.

<b>For Radio 1 : 3TX Configuration</b>						
MODE		AVAILABLE CHANNEL	TESTED CHANNEL	MODULATION TECHNOLOGY	MODULATION TYPE	DATA RATE (Mbps)
802.11g	CDD	1 to 11	6	OFDM	BPSK	6

**Power Line Conducted Emission Test:**

- Pre-Scan has been conducted to determine the worst-case mode from all possible combinations between available modulations, data rates and antenna ports (if EUT with antenna diversity architecture).
- Following channel(s) was (were) selected for the final test as listed below.

<b>For Radio 1 : 3TX Configuration</b>						
MODE		AVAILABLE CHANNEL	TESTED CHANNEL	MODULATION TECHNOLOGY	MODULATION TYPE	DATA RATE (Mbps)
802.11g	CDD	1 to 11	6	OFDM	BPSK	6

**Antenna Port Conducted Measurement:**

- This item includes all test value of each mode, but only includes spectrum plot of worst value of each mode.
- Pre-Scan has been conducted to determine the worst-case mode from all possible combinations between available modulations, data rates and antenna ports (if EUT with antenna diversity architecture).
- Following channel(s) was (were) selected for the final test as listed below.

<b>For Radio 1 : 3TX Configuration</b>							
MODE		ANTENNA COMBINATION	AVAILABLE CHANNEL	TESTED CHANNEL	MODULATION TECHNOLOGY	MODULATION TYPE	DATA RATE (Mbps)
802.11b	CDD	ANT1, ANT2, ANT3	1 to 11	1, 6, 11	DSSS	DBPSK	1
802.11g			1 to 11	1, 6, 11	OFDM	BPSK	6
802.11n (HT20)			1 to 11	1, 6, 11	OFDM	BPSK	6.5
VHT20			TxBF	1 to 11	1, 6, 11	OFDM	BPSK
<b>For Radio 1 : 2TX Configuration</b>							
MODE		ANTENNA COMBINATION	AVAILABLE CHANNEL	TESTED CHANNEL	MODULATION TECHNOLOGY	MODULATION TYPE	DATA RATE (Mbps)
802.11b	CDD	ANT1, ANT2	1 to 11	1, 6, 11	DSSS	DBPSK	1
802.11g			1 to 11	1, 6, 11	OFDM	BPSK	6
802.11n (HT20)			1 to 11	1, 6, 11	OFDM	BPSK	6.5
VHT20			TxBF	1 to 11	1, 6, 11	OFDM	BPSK
<b>For Radio 1 : 1TX Configuration</b>							
MODE		ANTENNA COMBINATION	AVAILABLE CHANNEL	TESTED CHANNEL	MODULATION TECHNOLOGY	MODULATION TYPE	DATA RATE (Mbps)
802.11b	ANT1	ANT1	1 to 11	1, 6, 11	DSSS	DBPSK	1
802.11g			1 to 11	1, 6, 11	OFDM	BPSK	6
802.11n(HT20)			1 to 11	1, 6, 11	OFDM	BPSK	6.5

**Test Condition:**

APPLICABLE TO	ENVIRONMENTAL CONDITIONS	INPUT POWER	TESTED BY	TEST LOCATION
RE $\geq$ 1G	24deg. C, 62%RH	120Vac, 60Hz	Weiwei Lo	1
RE $<$ 1G	25deg. C, 65%RH	120Vac, 60Hz	Nelson Teng	1
PLC	20deg. C, 61%RH	120Vac, 60Hz	Eagle Chen	2
APCM	25deg. C, 60%RH	120Vac, 60Hz	Robert Cheng	1

### 3.3 Duty Cycle of Test Signal

Duty cycle of test signal is  $\geq 98\%$ , duty factor is not required.

**802.11b:** Duty cycle =  $12.457/12.494 = 0.997$

**802.11g:** Duty cycle =  $2.062/2.093 = 0.985$

**802.11n (HT20):** Duty cycle =  $1.919/1.948 = 0.985$

**802.11b**

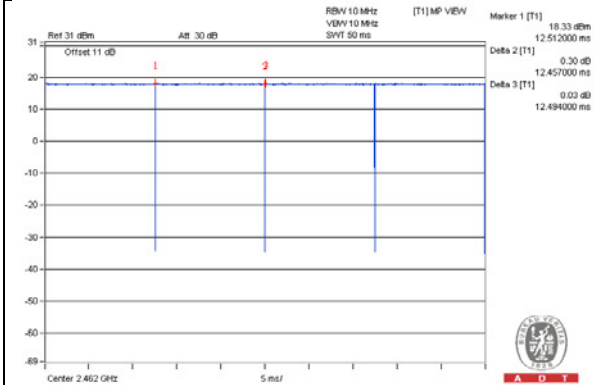

**802.11g**

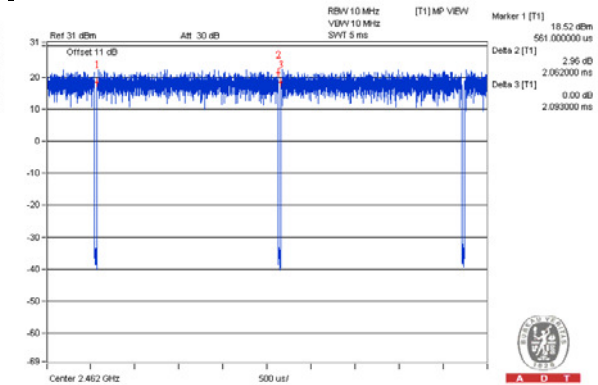

**802.11n (HT20)**

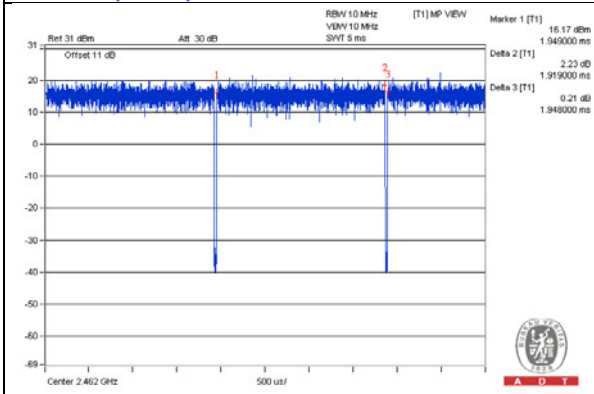

### 3.4 Description of Support Units

The EUT has been tested as an independent unit together with other necessary accessories or support units. The following support units or accessories were used to form a representative test configuration during the tests.

ID	Product	Brand	Model No.	Serial No.	FCC ID	Remarks
A.	iPod shuffle	Apple	MC749TA/A	CC4DN25WDFDM	NA	Provided by Lab
B.	POE	PowerDsine	PD-9001GR/AT/AC	NA	NA	Supplied by Client
			PD-3501G/AC	NA	NA	Supplied by Client
C.	Notebook Computer	DELL	E5440	6FC7F12	FCC DoC	Provided by Lab
D.	Notebook Computer	DELL	E5430	GM1SKV1	FCC DoC	Provided by Lab
E.	Flash Disk	SanDisk	SDCZ50-008G	NA	NA	Supplied by Client

Note:

1. All power cords of the above support units are non-shielded (1.8m).

ID	Descriptions	Qty.	Length (m)	Shielding (Yes/No)	Cores (Qty.)	Remarks
1.	RJ45 to RJ232	1	1.5	No	0	Provided by Lab
2.	USB	1	0.1	Yes	0	Provided by Lab
3.	UTP RJ45	1	10	No	0	Provided by Lab
4.	UTP RJ45	1	10	No	0	Provided by Lab
5.	UTP RJ45	1	1.8	No	0	Provided by Lab
6.	AC	1	1.8	No	0	Provided by Lab



### 3.4.1 Configuration of System under Test

For Radiated Emissions (below 1GHz) test:

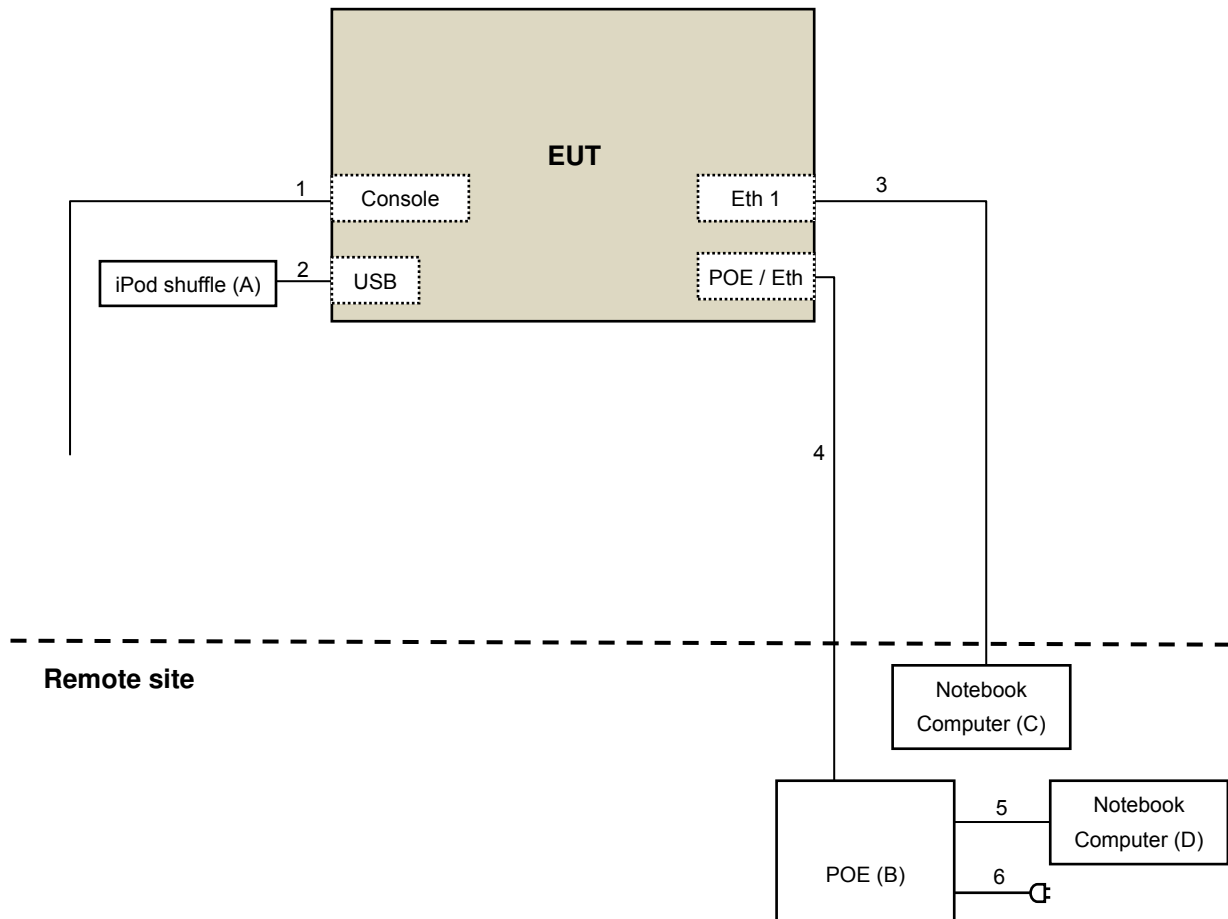

For other test:

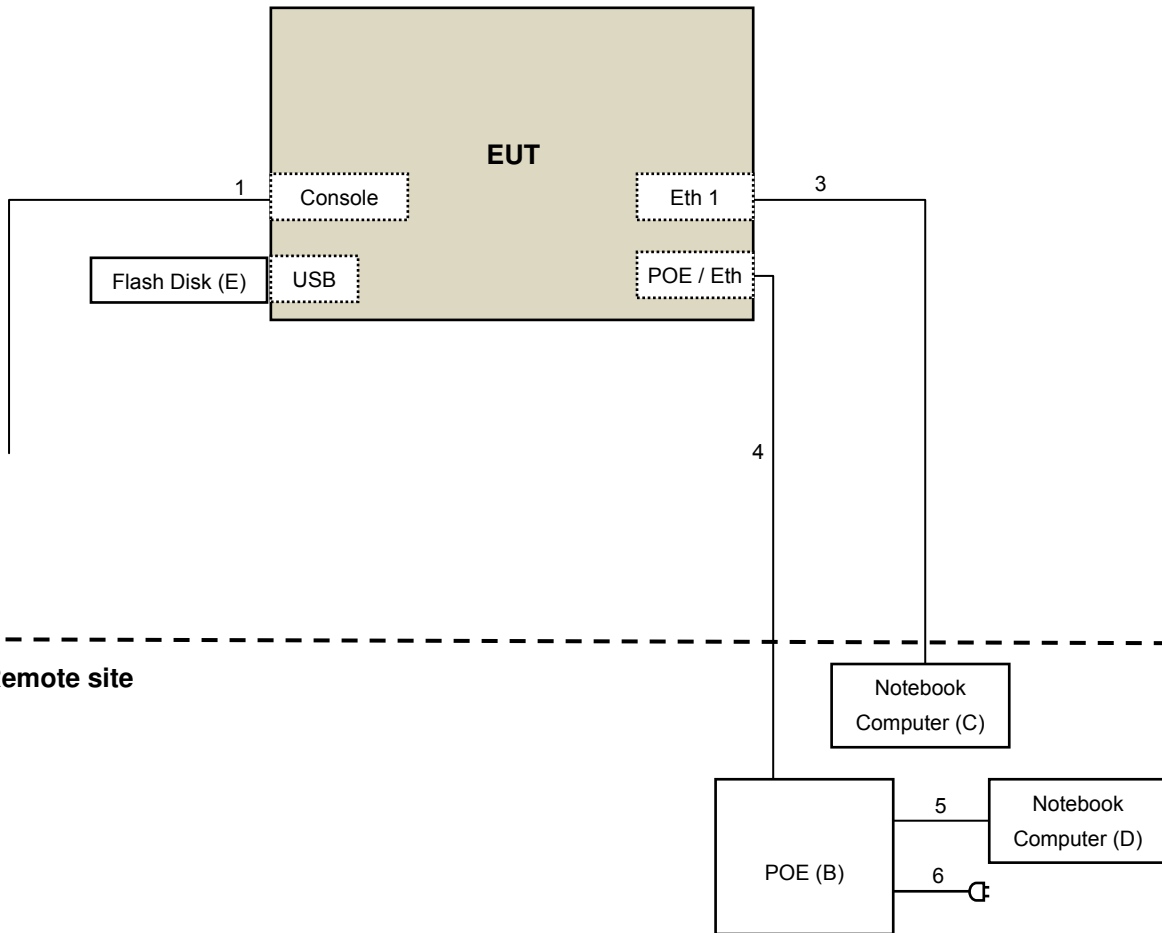

### 3.5 General Description of Applied Standards

The EUT is a RF Product. According to the specifications of the manufacturer, it must comply with the requirements of the following standards:

**FCC Part 15, Subpart C (15.247)**  
**KDB 558074 D01 DTS Meas Guidance v03r04**  
**KDB 662911 D01 Multiple Transmitter Output v02r01**  
ANSI C63.10-2013

All test items have been performed and recorded as per the above standards.

## 4 Test Types and Results

### 4.1 Radiated Emission and Bandedge Measurement

#### 4.1.1 Limits of Radiated Emission and Bandedge Measurement

Radiated emissions which fall in the restricted bands must comply with the radiated emission limits specified as below table. Other emissions shall be at least 30dB below the highest level of the desired power:

Frequencies (MHz)	Field Strength (microvolts/meter)	Measurement Distance (meters)
0.009 ~ 0.490	2400/F(kHz)	300
0.490 ~ 1.705	24000/F(kHz)	30
1.705 ~ 30.0	30	30
30 ~ 88	100	3
88 ~ 216	150	3
216 ~ 960	200	3
Above 960	500	3

**NOTE:**

1. The lower limit shall apply at the transition frequencies.
2. Emission level (dBuV/m) = 20 log Emission level (uV/m).
3. For frequencies above 1000MHz, the field strength limits are based on average detector, however, the peak field strength of any emission shall not exceed the maximum permitted average limits, specified above by more than 20dB under any condition of modulation.



#### 4.1.2 Test Instruments

For mode1 (below 1GHz) test:

DESCRIPTION & MANUFACTURER	MODEL NO.	SERIAL NO.	CALIBRATED DATE	CALIBRATED UNTIL
Test Receiver Agilent	N9038A	MY54450088	July 24, 2015	July 23, 2016
Pre-Amplifier Mini-Circuits	ZFL-1000VH2B	AMP-ZFL-06	Nov. 11, 2015	Nov. 10, 2016
Trilog Broadband Antenna SCHWARZBECK	VULB 9168	9168-406	Feb. 03, 2015	Feb. 02, 2016
RF Cable	8D	966-4-1 966-4-2 966-4-3	Apr. 03, 2015	Apr. 02, 2016
Software	ADT_Radiated_V8.7.07	NA	NA	NA
Antenna Tower & Turn Table CT	NA	NA	NA	NA

**Note:**

1. The calibration interval of the above test instruments is 12 months and the calibrations are traceable to NML/ROC and NIST/USA.
2. The test was performed in 966 Chamber No. 4.
3. The FCC Site Registration No. is 292998
4. The CANADA Site Registration No. is 20331-2
5. Tested Date: Dec. 15, 2015



A D T

For other test items:

DESCRIPTION & MANUFACTURER	MODEL NO.	SERIAL NO.	CALIBRATED DATE	CALIBRATED UNTIL
Test Receiver Agilent	N9038A	MY54450088	July 24, 2015	July 23, 2016
Pre-Amplifier <sup>(*)</sup> EMCI	EMC001340	980142	Jan. 20, 2016	Jan. 19, 2018
Loop Antenna <sup>(*)</sup> Electro-Metrics	EM-6879	264	Dec. 16, 2014	Dec. 15, 2016
RF Cable	NA	LOOPCAB-001 LOOPCAB-002	Jan. 18, 2016	Jan. 17, 2017
Pre-Amplifier Mini-Circuits	ZFL-1000VH2B	AMP-ZFL-01	Nov. 11, 2015	Nov. 10, 2016
Trilog Broadband Antenna SCHWARZBECK	VULB 9168	9168-406	Jan. 04, 2016	Jan. 03, 2017
RF Cable	8D	966-4-1 966-4-2 966-4-3	Apr. 03, 2015	Apr. 02, 2016
Horn_Antenna SCHWARZBECK	BBHA 9120D	9120D-783	Jan. 19, 2016	Jan. 18, 2017
Pre-Amplifier Agilent	8449B	3008A01922	Sep. 19, 2015	Sep. 18, 2016
RF Cable	EMC104-SM-SM-2000 EMC104-SM-SM-5000 EMC104-SM-SM-5000	150318 150323 150324	Mar. 31, 2015	Mar. 30, 2016
Pre-Amplifier EMCI	EMC184045	980143	Jan. 15, 2016	Jan. 14, 2017
Horn_Antenna SCHWARZBECK	BBHA 9170	BBHA9170608	Jan. 08, 2016	Jan. 07, 2017
RF Cable	SUCOFLEX 102	36432/2 36441/2	Jan. 16, 2016	Jan. 15, 2017
Software	ADT_Radiated_V8.7.07	NA	NA	NA
Antenna Tower & Turn Table CT	NA	NA	NA	NA
Boresight Antenna Fixture	NA	NA	NA	NA
Spectrum analyzer R&S	FSP 40	100060	May 08, 2015	May 07, 2016
Power meter Anritsu	ML2495A	1014008	Apr. 28, 2015	Apr. 27, 2016
Power sensor Anritsu	MA2411B	0917122	Apr. 28, 2015	Apr. 27, 2016

**Note:**

1. The calibration interval of the above test instruments is 12 months and the calibrations are traceable to NML/ROC and NIST/USA.
2. \*The calibration interval of the above test instruments is 24 months and the calibrations are traceable to NML/ROC and NIST/USA.
3. Loop antenna was used for all emissions below 30 MHz.
4. The test was performed in 966 Chamber No. 4.
5. The FCC Site Registration No. is 292998
6. The CANADA Site Registration No. is 20331-2
7. Tested Date: Dec. 15, 2015 to Mar. 11, 2016

#### 4.1.3 Test Procedures

- a. The EUT was placed on the top of a rotating table 0.8 meters (for below 1GHz) / 1.5 meters (for above 1GHz) above the ground at 3 meter chamber room for test. The table was rotated 360 degrees to determine the position of the highest radiation.
- b. The EUT was set 3 meters away from the interference-receiving antenna, which was mounted on the top of a variable-height antenna tower.
- c. The height of antenna is varied from one meter to four meters above the ground to determine the maximum value of the field strength. Both horizontal and vertical polarizations of the antenna are set to make the measurement.
- d. For each suspected emission, the EUT was arranged to its worst case and then the antenna was tuned to heights from 1 meter to 4 meters and the rotatable table was turned from 0 degrees to 360 degrees to find the maximum reading.
- e. The test-receiver system was set to quasi-peak detect function and specified bandwidth with maximum hold mode when the test frequency is below 1 GHz.
- f. The test-receiver system was set to peak and average detect function and specified bandwidth with maximum hold mode when the test frequency is above 1 GHz. If the peak reading value also meets average limit, measurement with the average detector is unnecessary.

**Note:**

1. The resolution bandwidth and video bandwidth of test receiver/spectrum analyzer is 120kHz for Quasi-peak detection (QP) at frequency below 1GHz.
2. The resolution bandwidth of test receiver/spectrum analyzer is 1 MHz and the video bandwidth is 3 MHz for Peak detection (PK) at frequency above 1GHz.
3. The resolution bandwidth of test receiver/spectrum analyzer is 1MHz and the video bandwidth is 3MHz for RMS Average (Duty cycle < 98%) for Average detection (AV) at frequency above 1GHz, then the measurement results was added to a correction factor ( $10 \log(1/\text{duty cycle})$ ).
4. The resolution bandwidth of test receiver/spectrum analyzer is 1MHz and the video bandwidth is 10Hz (Duty cycle  $\geq 98\%$ ) for Average detection (AV) at frequency above 1GHz.
5. All modes of operation were investigated and the worst-case emissions are reported.

#### 4.1.4 Deviation from Test Standard

No deviation.

#### 4.1.5 Test Setup

##### <Frequency Range below 1GHz>

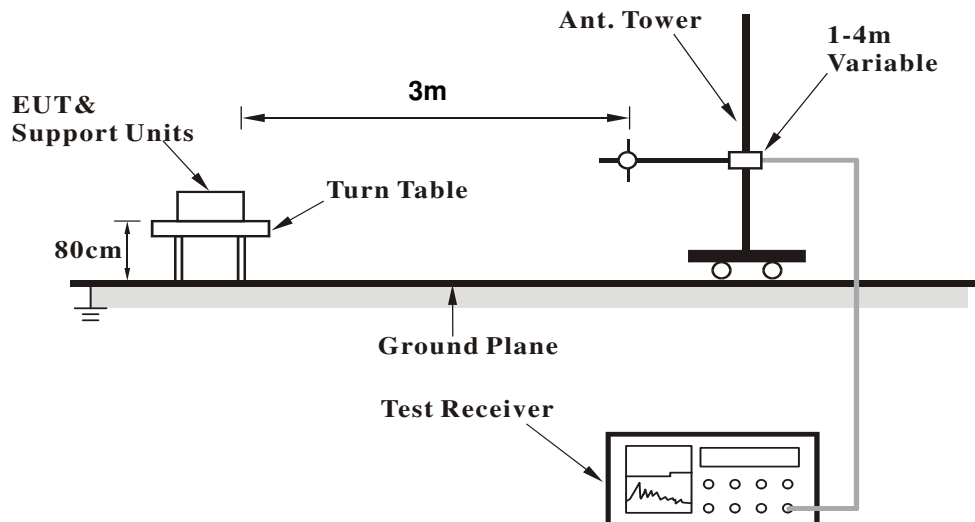

##### <Frequency Range above 1GHz>

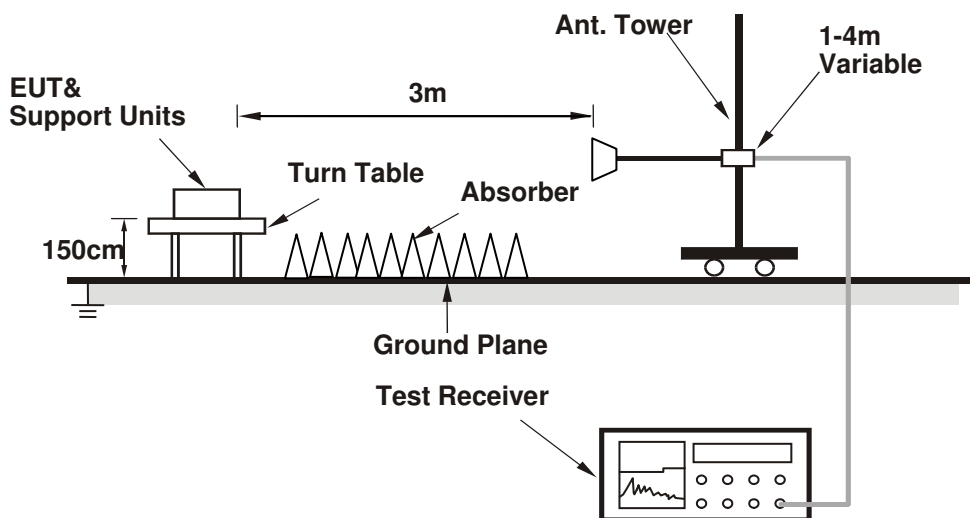

For the actual test configuration, please refer to the attached file (Test Setup Photo).

#### 4.1.6 EUT Operating Conditions

- a. Placed the EUT on the testing table.
- b. Prepared notebooks to act as communication partner and placed it outside of testing area.
- c. Controlling software (MTool.exe [2.0.2.8]) has been activated to set the EUT on specific status.



4.1.7 Test Results (Mode 1)

Above 1GHz Data:

3TX Mode

802.11b

<b>CHANNEL</b>	TX Channel 1	<b>DETECTOR FUNCTION</b>	Peak (PK)
<b>FREQUENCY RANGE</b>	1GHz ~ 25GHz		Average (AV)

ANTENNA POLARITY & TEST DISTANCE: HORIZONTAL AT 3 M								
NO.	FREQ. (MHz)	EMISSION LEVEL (dBuV/m)	LIMIT (dBuV/m)	MARGIN (dB)	ANTENNA HEIGHT (m)	TABLE ANGLE (Degree)	RAW VALUE (dBuV)	CORRECTION FACTOR (dB/m)
1	2390.00	51.4 PK	74.0	-22.6	1.48 H	142	57.20	-5.80
2	2390.00	42.9 AV	54.0	-11.1	1.48 H	142	48.70	-5.80
3	*2412.00	108.2 PK			1.48 H	142	113.92	-5.72
4	*2412.00	105.7 AV			1.48 H	142	111.42	-5.72
5	4824.00	47.6 PK	74.0	-26.4	1.00 H	243	47.50	0.10
6	4824.00	44.0 AV	54.0	-10.0	1.00 H	243	43.90	0.10

ANTENNA POLARITY & TEST DISTANCE: VERTICAL AT 3 M								
NO.	FREQ. (MHz)	EMISSION LEVEL (dBuV/m)	LIMIT (dBuV/m)	MARGIN (dB)	ANTENNA HEIGHT (m)	TABLE ANGLE (Degree)	RAW VALUE (dBuV)	CORRECTION FACTOR (dB/m)
1	2390.00	56.3 PK	74.0	-17.7	2.46 V	95	62.10	-5.80
2	2390.00	47.7 AV	54.0	-6.3	2.46 V	95	53.50	-5.80
3	*2412.00	116.4 PK			2.46 V	95	122.12	-5.72
4	*2412.00	113.9 AV			2.46 V	95	119.62	-5.72
5	4824.00	55.1 PK	74.0	-18.9	2.59 V	312	55.00	0.10
6	4824.00	53.8 AV	54.0	-0.2	2.59 V	312	53.70	0.10

REMARKS:

1. Emission Level(dBuV/m) = Raw Value(dBuV) + Correction Factor(dB/m)
2. Correction Factor(dB/m) = Antenna Factor(dB/m) + Cable Factor(dB) – Pre-Amplifier Factor(dB)
3. The other emission levels were very low against the limit.
4. Margin value = Emission Level – Limit value
5. " \* ": Fundamental frequency.

<b>CHANNEL</b>	TX Channel 6	<b>DETECTOR FUNCTION</b>	Peak (PK)
<b>FREQUENCY RANGE</b>	1GHz ~ 25GHz		Average (AV)

**ANTENNA POLARITY & TEST DISTANCE: HORIZONTAL AT 3 M**

NO.	FREQ. (MHz)	EMISSION LEVEL (dBuV/m)	LIMIT (dBuV/m)	MARGIN (dB)	ANTENNA HEIGHT (m)	TABLE ANGLE (Degree)	RAW VALUE (dBuV)	CORRECTION FACTOR (dB/m)
1	2390.00	47.2 PK	74.0	-26.8	1.39 H	148	53.00	-5.80
2	2390.00	34.6 AV	54.0	-19.4	1.39 H	148	40.40	-5.80
3	*2437.00	107.8 PK			1.39 H	148	113.43	-5.63
4	*2437.00	105.3 AV			1.39 H	148	110.93	-5.63
5	2483.50	50.7 PK	74.0	-23.3	1.39 H	148	56.18	-5.48
6	2483.50	37.2 AV	54.0	-16.8	1.39 H	148	42.68	-5.48
7	4874.00	48.1 PK	74.0	-25.9	1.06 H	240	47.83	0.27
8	4874.00	44.6 AV	54.0	-9.4	1.06 H	240	44.33	0.27
9	7311.00	52.6 PK	74.0	-21.4	1.02 H	245	45.83	6.77
10	7311.00	45.8 AV	54.0	-8.2	1.02 H	245	39.03	6.77

**ANTENNA POLARITY & TEST DISTANCE: VERTICAL AT 3 M**

NO.	FREQ. (MHz)	EMISSION LEVEL (dBuV/m)	LIMIT (dBuV/m)	MARGIN (dB)	ANTENNA HEIGHT (m)	TABLE ANGLE (Degree)	RAW VALUE (dBuV)	CORRECTION FACTOR (dB/m)
1	2390.00	50.5 PK	74.0	-23.5	2.45 V	94	56.30	-5.80
2	2390.00	38.2 AV	54.0	-15.8	2.45 V	94	44.00	-5.80
3	*2437.00	116.0 PK			2.45 V	94	121.63	-5.63
4	*2437.00	113.5 AV			2.45 V	94	119.13	-5.63
5	2483.50	55.6 PK	74.0	-18.4	2.45 V	94	61.08	-5.48
6	2483.50	42.1 AV	54.0	-11.9	2.45 V	94	47.58	-5.48
7	4874.00	55.7 PK	74.0	-18.3	2.59 V	305	55.43	0.27
8	4874.00	53.6 AV	54.0	-0.4	2.59 V	305	53.33	0.27
9	7311.00	56.5 PK	74.0	-17.5	2.59 V	257	49.73	6.77
10	7311.00	51.7 AV	54.0	-2.3	2.59 V	257	44.93	6.77

**REMARKS:**

1. Emission Level(dBuV/m) = Raw Value(dBuV) + Correction Factor(dB/m)
2. Correction Factor(dB/m) = Antenna Factor(dB/m) + Cable Factor(dB) – Pre-Amplifier Factor(dB)
3. The other emission levels were very low against the limit.
4. Margin value = Emission Level – Limit value
5. " \* ": Fundamental frequency.

<b>CHANNEL</b>	TX Channel 11	<b>DETECTOR FUNCTION</b>	Peak (PK)
<b>FREQUENCY RANGE</b>	1GHz ~ 25GHz		Average (AV)

**ANTENNA POLARITY & TEST DISTANCE: HORIZONTAL AT 3 M**

NO.	FREQ. (MHz)	EMISSION LEVEL (dBuV/m)	LIMIT (dBuV/m)	MARGIN (dB)	ANTENNA HEIGHT (m)	TABLE ANGLE (Degree)	RAW VALUE (dBuV)	CORRECTION FACTOR (dB/m)
1	*2462.00	107.3 PK			1.43 H	151	112.85	-5.55
2	*2462.00	104.8 AV			1.43 H	151	110.35	-5.55
3	2500.00	50.2 PK	74.0	-23.8	1.43 H	151	55.63	-5.43
4	2500.00	40.7 AV	54.0	-13.3	1.43 H	151	46.13	-5.43
5	4924.00	48.6 PK	74.0	-25.4	1.02 H	247	48.22	0.38
6	4924.00	45.0 AV	54.0	-9.0	1.02 H	247	44.62	0.38
7	7386.00	52.9 PK	74.0	-21.1	1.06 H	254	45.98	6.92
8	7386.00	46.3 AV	54.0	-7.7	1.06 H	254	39.38	6.92

**ANTENNA POLARITY & TEST DISTANCE: VERTICAL AT 3 M**

NO.	FREQ. (MHz)	EMISSION LEVEL (dBuV/m)	LIMIT (dBuV/m)	MARGIN (dB)	ANTENNA HEIGHT (m)	TABLE ANGLE (Degree)	RAW VALUE (dBuV)	CORRECTION FACTOR (dB/m)
1	*2462.00	115.5 PK			2.62 V	96	121.05	-5.55
2	*2462.00	113.0 AV			2.62 V	96	118.55	-5.55
3	2500.00	55.9 PK	74.0	-18.1	2.62 V	96	61.33	-5.43
4	2500.00	45.9 AV	54.0	-8.1	2.62 V	96	51.33	-5.43
5	4924.00	55.9 PK	74.0	-18.1	2.60 V	313	55.52	0.38
6	4924.00	53.7 AV	54.0	-0.3	2.60 V	313	53.32	0.38
7	7386.00	51.8 PK	74.0	-22.2	2.35 V	353	44.88	6.92
8	7386.00	44.0 AV	54.0	-10.0	2.35 V	353	37.08	6.92

**REMARKS:**

1. Emission Level(dBuV/m) = Raw Value(dBuV) + Correction Factor(dB/m)
2. Correction Factor(dB/m) = Antenna Factor(dB/m) + Cable Factor(dB) – Pre-Amplifier Factor(dB)
3. The other emission levels were very low against the limit.
4. Margin value = Emission Level – Limit value
5. " \* ": Fundamental frequency.

**802.11g**

<b>CHANNEL</b>	TX Channel 1	<b>DETECTOR FUNCTION</b>	Peak (PK)
<b>FREQUENCY RANGE</b>	1GHz ~ 25GHz		Average (AV)

**ANTENNA POLARITY & TEST DISTANCE: HORIZONTAL AT 3 M**

NO.	FREQ. (MHz)	EMISSION LEVEL (dBuV/m)	LIMIT (dBuV/m)	MARGIN (dB)	ANTENNA HEIGHT (m)	TABLE ANGLE (Degree)	RAW VALUE (dBuV)	CORRECTION FACTOR (dB/m)
1	2390.00	63.5 PK	74.0	-10.5	1.05 H	148	69.30	-5.80
2	2390.00	41.2 AV	54.0	-12.8	1.05 H	148	47.00	-5.80
3	*2412.00	108.1 PK			1.05 H	140	113.82	-5.72
4	*2412.00	98.0 AV			1.05 H	140	103.72	-5.72
5	4824.00	47.3 PK	74.0	-26.7	1.04 H	234	47.20	0.10
6	4824.00	43.8 AV	54.0	-10.2	1.04 H	234	43.70	0.10

**ANTENNA POLARITY & TEST DISTANCE: VERTICAL AT 3 M**

NO.	FREQ. (MHz)	EMISSION LEVEL (dBuV/m)	LIMIT (dBuV/m)	MARGIN (dB)	ANTENNA HEIGHT (m)	TABLE ANGLE (Degree)	RAW VALUE (dBuV)	CORRECTION FACTOR (dB/m)
1	2390.00	73.5 PK	74.0	-0.5	2.72 V	335	79.30	-5.80
2	2390.00	51.5 AV	54.0	-2.5	2.72 V	335	57.30	-5.80
3	*2412.00	116.1 PK			2.72 V	335	121.82	-5.72
4	*2412.00	106.2 AV			2.72 V	335	111.92	-5.72
5	4824.00	64.5 PK	74.0	-9.5	2.81 V	140	64.40	0.10
6	4824.00	50.9 AV	54.0	-3.1	2.81 V	140	50.80	0.10

**REMARKS:**

1. Emission Level(dBuV/m) = Raw Value(dBuV) + Correction Factor(dB/m)
2. Correction Factor(dB/m) = Antenna Factor(dB/m) + Cable Factor(dB) – Pre-Amplifier Factor(dB)
3. The other emission levels were very low against the limit.
4. Margin value = Emission Level – Limit value
5. " \* ": Fundamental frequency.

<b>CHANNEL</b>	TX Channel 6	<b>DETECTOR FUNCTION</b>	Peak (PK)
<b>FREQUENCY RANGE</b>	1GHz ~ 25GHz		Average (AV)

**ANTENNA POLARITY & TEST DISTANCE: HORIZONTAL AT 3 M**

NO.	FREQ. (MHz)	EMISSION LEVEL (dBuV/m)	LIMIT (dBuV/m)	MARGIN (dB)	ANTENNA HEIGHT (m)	TABLE ANGLE (Degree)	RAW VALUE (dBuV)	CORRECTION FACTOR (dB/m)
1	2390.00	57.1 PK	74.0	-16.9	1.04 H	145	62.90	-5.80
2	2390.00	41.1 AV	54.0	-12.9	1.04 H	145	46.90	-5.80
3	*2437.00	112.4 PK			1.05 H	138	118.03	-5.63
4	*2437.00	102.2 AV			1.05 H	138	107.83	-5.63
5	2483.50	61.9 PK	74.0	-12.1	1.05 H	143	67.38	-5.48
6	2483.50	43.7 AV	54.0	-10.3	1.05 H	143	49.18	-5.48
7	4874.00	48.0 PK	74.0	-26.0	1.10 H	245	47.73	0.27
8	4874.00	44.4 AV	54.0	-9.6	1.10 H	245	44.13	0.27
9	7311.00	52.3 PK	74.0	-21.7	1.05 H	256	45.53	6.77
10	7311.00	45.4 AV	54.0	-8.6	1.05 H	256	38.63	6.77

**ANTENNA POLARITY & TEST DISTANCE: VERTICAL AT 3 M**

NO.	FREQ. (MHz)	EMISSION LEVEL (dBuV/m)	LIMIT (dBuV/m)	MARGIN (dB)	ANTENNA HEIGHT (m)	TABLE ANGLE (Degree)	RAW VALUE (dBuV)	CORRECTION FACTOR (dB/m)
1	2390.00	66.6 PK	74.0	-7.4	2.74 V	337	72.40	-5.80
2	2390.00	51.1 AV	54.0	-2.9	2.74 V	337	56.90	-5.80
3	*2437.00	120.5 PK			2.74 V	337	126.13	-5.63
4	*2437.00	110.6 AV			2.74 V	337	116.23	-5.63
5	2483.50	71.2 PK	74.0	-2.8	2.74 V	337	76.68	-5.48
6	2483.50	53.3 AV	54.0	-0.7	2.74 V	337	58.78	-5.48
7	4874.00	64.9 PK	74.0	-9.1	2.80 V	141	64.63	0.27
8	4874.00	51.2 AV	54.0	-2.8	2.80 V	141	50.93	0.27
9	7311.00	51.7 PK	74.0	-22.3	2.29 V	288	44.93	6.77
10	7311.00	41.4 AV	54.0	-12.6	2.29 V	288	34.63	6.77

**REMARKS:**

1. Emission Level(dBuV/m) = Raw Value(dBuV) + Correction Factor(dB/m)
2. Correction Factor(dB/m) = Antenna Factor(dB/m) + Cable Factor(dB) – Pre-Amplifier Factor(dB)
3. The other emission levels were very low against the limit.
4. Margin value = Emission Level – Limit value
5. " \* ": Fundamental frequency.



<b>CHANNEL</b>	TX Channel 11	<b>DETECTOR FUNCTION</b>	Peak (PK)
<b>FREQUENCY RANGE</b>	1GHz ~ 25GHz		Average (AV)

**ANTENNA POLARITY & TEST DISTANCE: HORIZONTAL AT 3 M**

NO.	FREQ. (MHz)	EMISSION LEVEL (dBuV/m)	LIMIT (dBuV/m)	MARGIN (dB)	ANTENNA HEIGHT (m)	TABLE ANGLE (Degree)	RAW VALUE (dBuV)	CORRECTION FACTOR (dB/m)
1	*2462.00	108.3 PK			1.05 H	148	113.85	-5.55
2	*2462.00	98.6 AV			1.05 H	148	104.15	-5.55
3	2483.50	63.0 PK	74.0	-11.0	1.04 H	141	68.48	-5.48
4	2483.50	43.5 AV	54.0	-10.5	1.04 H	141	48.98	-5.48
5	4924.00	48.4 PK	74.0	-25.6	1.03 H	233	48.02	0.38
6	4924.00	44.8 AV	54.0	-9.2	1.03 H	233	44.42	0.38
7	7386.00	53.3 PK	74.0	-20.7	1.03 H	245	46.38	6.92
8	7386.00	46.7 AV	54.0	-7.3	1.03 H	245	39.78	6.92

**ANTENNA POLARITY & TEST DISTANCE: VERTICAL AT 3 M**

NO.	FREQ. (MHz)	EMISSION LEVEL (dBuV/m)	LIMIT (dBuV/m)	MARGIN (dB)	ANTENNA HEIGHT (m)	TABLE ANGLE (Degree)	RAW VALUE (dBuV)	CORRECTION FACTOR (dB/m)
1	*2462.00	116.2 PK			3.00 V	334	121.75	-5.55
2	*2462.00	106.7 AV			3.00 V	334	112.25	-5.55
3	2483.50	73.1 PK	74.0	-0.9	3.00 V	334	78.58	-5.48
4	2483.50	53.7 AV	54.0	-0.3	3.00 V	334	59.18	-5.48
5	4924.00	65.1 PK	74.0	-8.9	2.85 V	157	64.72	0.38
6	4924.00	51.6 AV	54.0	-2.4	2.85 V	157	51.22	0.38
7	7386.00	51.7 PK	74.0	-22.3	2.33 V	297	44.78	6.92
8	7386.00	41.2 AV	54.0	-12.8	2.33 V	297	34.28	6.92

**REMARKS:**

1. Emission Level(dBuV/m) = Raw Value(dBuV) + Correction Factor(dB/m)
2. Correction Factor(dB/m) = Antenna Factor(dB/m) + Cable Factor(dB) – Pre-Amplifier Factor(dB)
3. The other emission levels were very low against the limit.
4. Margin value = Emission Level – Limit value
5. " \* ": Fundamental frequency.

**802.11n (HT20)**

<b>CHANNEL</b>	TX Channel 1	<b>DETECTOR FUNCTION</b>	Peak (PK)
<b>FREQUENCY RANGE</b>	1GHz ~ 25GHz		Average (AV)

**ANTENNA POLARITY & TEST DISTANCE: HORIZONTAL AT 3 M**

NO.	FREQ. (MHz)	EMISSION LEVEL (dBuV/m)	LIMIT (dBuV/m)	MARGIN (dB)	ANTENNA HEIGHT (m)	TABLE ANGLE (Degree)	RAW VALUE (dBuV)	CORRECTION FACTOR (dB/m)
1	2390.00	64.0 PK	74.0	-10.0	1.10 H	150	69.80	-5.80
2	2390.00	41.7 AV	54.0	-12.3	1.10 H	150	47.50	-5.80
3	*2412.00	105.3 PK			1.05 H	139	111.02	-5.72
4	*2412.00	95.0 AV			1.05 H	139	100.72	-5.72
5	4824.00	47.7 PK	74.0	-26.3	1.05 H	232	47.60	0.10
6	4824.00	44.1 AV	54.0	-9.9	1.05 H	232	44.00	0.10

**ANTENNA POLARITY & TEST DISTANCE: VERTICAL AT 3 M**

NO.	FREQ. (MHz)	EMISSION LEVEL (dBuV/m)	LIMIT (dBuV/m)	MARGIN (dB)	ANTENNA HEIGHT (m)	TABLE ANGLE (Degree)	RAW VALUE (dBuV)	CORRECTION FACTOR (dB/m)
1	2390.00	73.4 PK	74.0	-0.6	2.91 V	334	79.20	-5.80
2	2390.00	50.6 AV	54.0	-3.4	2.91 V	334	56.40	-5.80
3	*2412.00	113.2 PK			2.91 V	334	118.92	-5.72
4	*2412.00	103.0 AV			2.91 V	334	108.72	-5.72
5	4824.00	63.1 PK	74.0	-10.9	2.52 V	147	63.00	0.10
6	4824.00	50.2 AV	54.0	-3.8	2.52 V	147	50.10	0.10

**REMARKS:**

1. Emission Level(dBuV/m) = Raw Value(dBuV) + Correction Factor(dB/m)
2. Correction Factor(dB/m) = Antenna Factor(dB/m) + Cable Factor(dB) – Pre-Amplifier Factor(dB)
3. The other emission levels were very low against the limit.
4. Margin value = Emission Level – Limit value
5. " \* ": Fundamental frequency.

<b>CHANNEL</b>	TX Channel 6	<b>DETECTOR FUNCTION</b>	Peak (PK)
<b>FREQUENCY RANGE</b>	1GHz ~ 25GHz		Average (AV)

**ANTENNA POLARITY & TEST DISTANCE: HORIZONTAL AT 3 M**

NO.	FREQ. (MHz)	EMISSION LEVEL (dBuV/m)	LIMIT (dBuV/m)	MARGIN (dB)	ANTENNA HEIGHT (m)	TABLE ANGLE (Degree)	RAW VALUE (dBuV)	CORRECTION FACTOR (dB/m)
1	2390.00	56.8 PK	74.0	-17.2	1.05 H	146	62.60	-5.80
2	2390.00	41.1 AV	54.0	-12.9	1.05 H	146	46.90	-5.80
3	*2437.00	112.6 PK			1.01 H	128	118.23	-5.63
4	*2437.00	102.4 AV			1.01 H	128	108.03	-5.63
5	2483.50	61.9 PK	74.0	-12.1	1.00 H	135	67.38	-5.48
6	2483.50	43.9 AV	54.0	-10.1	1.00 H	135	49.38	-5.48
7	4874.00	48.1 PK	74.0	-25.9	1.04 H	245	47.83	0.27
8	4874.00	44.6 AV	54.0	-9.4	1.04 H	245	44.33	0.27
9	7311.00	52.3 PK	74.0	-21.7	1.05 H	267	45.53	6.77
10	7311.00	45.2 AV	54.0	-8.8	1.05 H	267	38.43	6.77

**ANTENNA POLARITY & TEST DISTANCE: VERTICAL AT 3 M**

NO.	FREQ. (MHz)	EMISSION LEVEL (dBuV/m)	LIMIT (dBuV/m)	MARGIN (dB)	ANTENNA HEIGHT (m)	TABLE ANGLE (Degree)	RAW VALUE (dBuV)	CORRECTION FACTOR (dB/m)
1	2390.00	67.2 PK	74.0	-6.8	2.74 V	336	73.00	-5.80
2	2390.00	52.7 AV	54.0	-1.3	2.74 V	336	58.50	-5.80
3	*2437.00	120.0 PK			2.74 V	336	125.63	-5.63
4	*2437.00	109.7 AV			2.74 V	336	115.33	-5.63
5	2483.50	69.7 PK	74.0	-4.3	2.74 V	336	75.18	-5.48
6	2483.50	53.5 AV	54.0	-0.5	2.74 V	336	58.98	-5.48
7	4874.00	63.2 PK	74.0	-10.8	2.55 V	139	62.93	0.27
8	4874.00	50.4 AV	54.0	-3.6	2.55 V	139	50.13	0.27
9	7311.00	51.5 PK	74.0	-22.5	2.32 V	288	44.73	6.77
10	7311.00	41.0 AV	54.0	-13.0	2.32 V	288	34.23	6.77

**REMARKS:**

1. Emission Level(dBuV/m) = Raw Value(dBuV) + Correction Factor(dB/m)
2. Correction Factor(dB/m) = Antenna Factor(dB/m) + Cable Factor(dB) – Pre-Amplifier Factor(dB)
3. The other emission levels were very low against the limit.
4. Margin value = Emission Level – Limit value
5. " \* ": Fundamental frequency.



<b>CHANNEL</b>	TX Channel 11	<b>DETECTOR FUNCTION</b>	Peak (PK)
<b>FREQUENCY RANGE</b>	1GHz ~ 25GHz		Average (AV)

**ANTENNA POLARITY & TEST DISTANCE: HORIZONTAL AT 3 M**

NO.	FREQ. (MHz)	EMISSION LEVEL (dBuV/m)	LIMIT (dBuV/m)	MARGIN (dB)	ANTENNA HEIGHT (m)	TABLE ANGLE (Degree)	RAW VALUE (dBuV)	CORRECTION FACTOR (dB/m)
1	*2462.00	104.6 PK			1.06 H	134	110.15	-5.55
2	*2462.00	95.1 AV			1.06 H	134	100.65	-5.55
3	2483.50	62.9 PK	74.0	-11.1	1.02 H	155	68.38	-5.48
4	2483.50	43.7 AV	54.0	-10.3	1.02 H	155	49.18	-5.48
5	4924.00	48.8 PK	74.0	-25.2	1.02 H	234	48.42	0.38
6	4924.00	44.9 AV	54.0	-9.1	1.02 H	234	44.52	0.38
7	7386.00	53.4 PK	74.0	-20.6	1.00 H	247	46.48	6.92
8	7386.00	47.0 AV	54.0	-7.0	1.00 H	247	40.08	6.92

**ANTENNA POLARITY & TEST DISTANCE: VERTICAL AT 3 M**

NO.	FREQ. (MHz)	EMISSION LEVEL (dBuV/m)	LIMIT (dBuV/m)	MARGIN (dB)	ANTENNA HEIGHT (m)	TABLE ANGLE (Degree)	RAW VALUE (dBuV)	CORRECTION FACTOR (dB/m)
1	*2462.00	112.3 PK			3.00 V	332	117.85	-5.55
2	*2462.00	102.8 AV			3.00 V	332	108.35	-5.55
3	2483.50	73.4 PK	74.0	-0.6	3.00 V	332	78.88	-5.48
4	2483.50	53.3 AV	54.0	-0.7	3.00 V	332	58.78	-5.48
5	4924.00	63.7 PK	74.0	-10.3	2.50 V	145	63.32	0.38
6	4924.00	50.7 AV	54.0	-3.3	2.50 V	145	50.32	0.38
7	7386.00	51.8 PK	74.0	-22.2	2.28 V	306	44.88	6.92
8	7386.00	41.5 AV	54.0	-12.5	2.28 V	306	34.58	6.92

**REMARKS:**

1. Emission Level(dBuV/m) = Raw Value(dBuV) + Correction Factor(dB/m)
2. Correction Factor(dB/m) = Antenna Factor(dB/m) + Cable Factor(dB) – Pre-Amplifier Factor(dB)
3. The other emission levels were very low against the limit.
4. Margin value = Emission Level – Limit value
5. " \* ": Fundamental frequency.

**2TX Mode**
**802.11b**

<b>CHANNEL</b>	TX Channel 1	<b>DETECTOR FUNCTION</b>	Peak (PK)
<b>FREQUENCY RANGE</b>	1GHz ~ 25GHz		Average (AV)

**ANTENNA POLARITY & TEST DISTANCE: HORIZONTAL AT 3 M**

NO.	FREQ. (MHz)	EMISSION LEVEL (dBuV/m)	LIMIT (dBuV/m)	MARGIN (dB)	ANTENNA HEIGHT (m)	TABLE ANGLE (Degree)	RAW VALUE (dBuV)	CORRECTION FACTOR (dB/m)
1	2390.00	54.6 PK	74.0	-19.4	1.25 H	102	60.40	-5.80
2	2390.00	42.5 AV	54.0	-11.5	1.25 H	102	48.30	-5.80
3	*2412.00	108.3 PK			1.25 H	102	114.02	-5.72
4	*2412.00	105.4 AV			1.25 H	102	111.12	-5.72
5	4824.00	49.5 PK	74.0	-24.5	1.03 H	41	49.40	0.10
6	4824.00	46.7 AV	54.0	-7.3	1.03 H	41	46.60	0.10

**ANTENNA POLARITY & TEST DISTANCE: VERTICAL AT 3 M**

NO.	FREQ. (MHz)	EMISSION LEVEL (dBuV/m)	LIMIT (dBuV/m)	MARGIN (dB)	ANTENNA HEIGHT (m)	TABLE ANGLE (Degree)	RAW VALUE (dBuV)	CORRECTION FACTOR (dB/m)
1	2390.00	58.6 PK	74.0	-15.4	2.83 V	88	64.40	-5.80
2	2390.00	46.7 AV	54.0	-7.3	2.83 V	88	52.50	-5.80
3	*2412.00	115.2 PK			2.83 V	88	120.92	-5.72
4	*2412.00	112.1 AV			2.83 V	88	117.82	-5.72
5	4824.00	55.4 PK	74.0	-18.6	2.89 V	306	55.30	0.10
6	4824.00	53.4 AV	54.0	-0.6	2.89 V	306	53.30	0.10

**REMARKS:**

1. Emission Level(dBuV/m) = Raw Value(dBuV) + Correction Factor(dB/m)
2. Correction Factor(dB/m) = Antenna Factor(dB/m) + Cable Factor(dB) – Pre-Amplifier Factor(dB)
3. The other emission levels were very low against the limit.
4. Margin value = Emission Level – Limit value
5. " \* ": Fundamental frequency.

<b>CHANNEL</b>	TX Channel 6	<b>DETECTOR FUNCTION</b>	Peak (PK)
<b>FREQUENCY RANGE</b>	1GHz ~ 25GHz		Average (AV)

**ANTENNA POLARITY & TEST DISTANCE: HORIZONTAL AT 3 M**

NO.	FREQ. (MHz)	EMISSION LEVEL (dBuV/m)	LIMIT (dBuV/m)	MARGIN (dB)	ANTENNA HEIGHT (m)	TABLE ANGLE (Degree)	RAW VALUE (dBuV)	CORRECTION FACTOR (dB/m)
1	2390.00	48.4 PK	74.0	-25.6	1.20 H	112	54.20	-5.80
2	2390.00	35.2 AV	54.0	-18.8	1.20 H	112	41.00	-5.80
3	*2437.00	108.0 PK			1.20 H	112	113.63	-5.63
4	*2437.00	104.9 AV			1.20 H	112	110.53	-5.63
5	2483.50	50.0 PK	74.0	-24.0	1.20 H	112	55.48	-5.48
6	2483.50	36.5 AV	54.0	-17.5	1.20 H	112	41.98	-5.48
7	4874.00	49.6 PK	74.0	-24.4	1.00 H	43	49.33	0.27
8	4874.00	46.7 AV	54.0	-7.3	1.00 H	43	46.43	0.27
9	7311.00	52.8 PK	74.0	-21.2	1.00 H	33	46.03	6.77
10	7311.00	45.9 AV	54.0	-8.1	1.00 H	33	39.13	6.77

**ANTENNA POLARITY & TEST DISTANCE: VERTICAL AT 3 M**

NO.	FREQ. (MHz)	EMISSION LEVEL (dBuV/m)	LIMIT (dBuV/m)	MARGIN (dB)	ANTENNA HEIGHT (m)	TABLE ANGLE (Degree)	RAW VALUE (dBuV)	CORRECTION FACTOR (dB/m)
1	2390.00	52.8 PK	74.0	-21.2	2.77 V	85	58.60	-5.80
2	2390.00	38.3 AV	54.0	-15.7	2.77 V	85	44.10	-5.80
3	*2437.00	114.9 PK			2.77 V	85	120.53	-5.63
4	*2437.00	111.9 AV			2.77 V	85	117.53	-5.63
5	2483.50	54.1 PK	74.0	-19.9	2.77 V	85	59.58	-5.48
6	2483.50	40.8 AV	54.0	-13.2	2.77 V	85	46.28	-5.48
7	4874.00	55.6 PK	74.0	-18.4	3.04 V	360	55.33	0.27
<b>8</b>	<b>4874.00</b>	<b>53.9 AV</b>	<b>54.0</b>	<b>-0.1</b>	<b>3.04 V</b>	<b>360</b>	<b>53.63</b>	<b>0.27</b>
9	7311.00	57.6 PK	74.0	-16.4	3.05 V	360	50.83	6.77
10	7311.00	52.9 AV	54.0	-1.1	3.05 V	360	46.13	6.77

**REMARKS:**

1. Emission Level(dBuV/m) = Raw Value(dBuV) + Correction Factor(dB/m)
2. Correction Factor(dB/m) = Antenna Factor(dB/m) + Cable Factor(dB) – Pre-Amplifier Factor(dB)
3. The other emission levels were very low against the limit.
4. Margin value = Emission Level – Limit value
5. " \* ": Fundamental frequency.

<b>CHANNEL</b>	TX Channel 11	<b>DETECTOR FUNCTION</b>	Peak (PK)
<b>FREQUENCY RANGE</b>	1GHz ~ 25GHz		Average (AV)

**ANTENNA POLARITY & TEST DISTANCE: HORIZONTAL AT 3 M**

NO.	FREQ. (MHz)	EMISSION LEVEL (dBuV/m)	LIMIT (dBuV/m)	MARGIN (dB)	ANTENNA HEIGHT (m)	TABLE ANGLE (Degree)	RAW VALUE (dBuV)	CORRECTION FACTOR (dB/m)
1	*2462.00	107.9 PK			1.24 H	127	113.45	-5.55
2	*2462.00	104.7 AV			1.24 H	127	110.25	-5.55
3	2483.50	56.0 PK	74.0	-18.0	1.24 H	127	61.48	-5.48
4	2483.50	46.7 AV	54.0	-7.3	1.24 H	127	52.18	-5.48
5	4924.00	49.0 PK	74.0	-25.0	1.00 H	35	48.62	0.38
6	4924.00	46.4 AV	54.0	-7.6	1.00 H	35	46.02	0.38
7	7386.00	52.4 PK	74.0	-21.6	1.00 H	39	45.48	6.92
8	7386.00	45.2 AV	54.0	-8.8	1.00 H	39	38.28	6.92

**ANTENNA POLARITY & TEST DISTANCE: VERTICAL AT 3 M**

NO.	FREQ. (MHz)	EMISSION LEVEL (dBuV/m)	LIMIT (dBuV/m)	MARGIN (dB)	ANTENNA HEIGHT (m)	TABLE ANGLE (Degree)	RAW VALUE (dBuV)	CORRECTION FACTOR (dB/m)
1	*2462.00	114.9 PK			2.63 V	90	120.45	-5.55
2	*2462.00	111.7 AV			2.63 V	90	117.25	-5.55
3	2483.50	60.2 PK	74.0	-13.8	2.63 V	90	65.68	-5.48
4	2483.50	50.9 AV	54.0	-3.1	2.63 V	90	56.38	-5.48
5	4924.00	55.3 PK	74.0	-18.7	3.06 V	357	54.92	0.38
6	4924.00	53.4 AV	54.0	-0.6	3.06 V	357	53.02	0.38
7	7386.00	57.2 PK	74.0	-16.8	2.73 V	289	50.28	6.92
8	7386.00	52.2 AV	54.0	-1.8	2.73 V	289	45.28	6.92

**REMARKS:**

1. Emission Level(dBuV/m) = Raw Value(dBuV) + Correction Factor(dB/m)
2. Correction Factor(dB/m) = Antenna Factor(dB/m) + Cable Factor(dB) – Pre-Amplifier Factor(dB)
3. The other emission levels were very low against the limit.
4. Margin value = Emission Level – Limit value
5. " \* ": Fundamental frequency.

**802.11g**

<b>CHANNEL</b>	TX Channel 1	<b>DETECTOR FUNCTION</b>	Peak (PK)
<b>FREQUENCY RANGE</b>	1GHz ~ 25GHz		Average (AV)

<b>ANTENNA POLARITY &amp; TEST DISTANCE: HORIZONTAL AT 3 M</b>								
NO.	FREQ. (MHz)	EMISSION LEVEL (dBuV/m)	LIMIT (dBuV/m)	MARGIN (dB)	ANTENNA HEIGHT (m)	TABLE ANGLE (Degree)	RAW VALUE (dBuV)	CORRECTION FACTOR (dB/m)
1	2390.00	69.6 PK	74.0	-4.4	1.27 H	138	75.40	-5.80
2	2390.00	46.3 AV	54.0	-7.7	1.27 H	138	52.10	-5.80
3	*2412.00	107.7 PK			1.00 H	208	113.42	-5.72
4	*2412.00	97.2 AV			1.00 H	208	102.92	-5.72
5	4824.00	49.9 PK	74.0	-24.1	1.20 H	237	49.80	0.10
6	4824.00	45.7 AV	54.0	-8.3	1.20 H	237	45.60	0.10

<b>ANTENNA POLARITY &amp; TEST DISTANCE: VERTICAL AT 3 M</b>								
NO.	FREQ. (MHz)	EMISSION LEVEL (dBuV/m)	LIMIT (dBuV/m)	MARGIN (dB)	ANTENNA HEIGHT (m)	TABLE ANGLE (Degree)	RAW VALUE (dBuV)	CORRECTION FACTOR (dB/m)
<b>1</b>	<b>2390.00</b>	<b>73.9 PK</b>	<b>74.0</b>	<b>-0.1</b>	<b>3.22 V</b>	<b>305</b>	<b>79.70</b>	<b>-5.80</b>
2	2390.00	51.1 AV	54.0	-2.9	3.22 V	305	56.90	-5.80
3	*2412.00	114.7 PK			3.22 V	305	120.42	-5.72
4	*2412.00	104.2 AV			3.22 V	305	109.92	-5.72
5	4824.00	49.5 PK	74.0	-24.5	1.35 V	240	49.40	0.10
6	4824.00	45.1 AV	54.0	-8.9	1.35 V	240	45.00	0.10

**REMARKS:**

1. Emission Level(dBuV/m) = Raw Value(dBuV) + Correction Factor(dB/m)
2. Correction Factor(dB/m) = Antenna Factor(dB/m) + Cable Factor(dB) – Pre-Amplifier Factor(dB)
3. The other emission levels were very low against the limit.
4. Margin value = Emission Level – Limit value
5. " \* ": Fundamental frequency.

<b>CHANNEL</b>	TX Channel 6	<b>DETECTOR FUNCTION</b>	Peak (PK)
<b>FREQUENCY RANGE</b>	1GHz ~ 25GHz		Average (AV)

**ANTENNA POLARITY & TEST DISTANCE: HORIZONTAL AT 3 M**

NO.	FREQ. (MHz)	EMISSION LEVEL (dBuV/m)	LIMIT (dBuV/m)	MARGIN (dB)	ANTENNA HEIGHT (m)	TABLE ANGLE (Degree)	RAW VALUE (dBuV)	CORRECTION FACTOR (dB/m)
1	2390.00	61.8 PK	74.0	-12.2	1.20 H	208	67.60	-5.80
2	2390.00	43.5 AV	54.0	-10.5	1.20 H	208	49.30	-5.80
3	*2437.00	112.3 PK			1.20 H	208	117.93	-5.63
4	*2437.00	101.9 AV			1.20 H	208	107.53	-5.63
5	2483.50	61.3 PK	74.0	-12.7	1.20 H	208	66.78	-5.48
6	2483.50	43.1 AV	54.0	-10.9	1.20 H	208	48.58	-5.48
7	4874.00	50.1 PK	74.0	-23.9	1.00 H	249	49.83	0.27
8	4874.00	45.6 AV	54.0	-8.4	1.00 H	249	45.33	0.27
9	7311.00	50.1 PK	74.0	-23.9	1.11 H	248	43.33	6.77
10	7311.00	43.9 AV	54.0	-10.1	1.11 H	248	37.13	6.77

**ANTENNA POLARITY & TEST DISTANCE: VERTICAL AT 3 M**

NO.	FREQ. (MHz)	EMISSION LEVEL (dBuV/m)	LIMIT (dBuV/m)	MARGIN (dB)	ANTENNA HEIGHT (m)	TABLE ANGLE (Degree)	RAW VALUE (dBuV)	CORRECTION FACTOR (dB/m)
1	2390.00	69.0 PK	74.0	-5.0	2.60 V	309	74.80	-5.80
2	2390.00	50.8 AV	54.0	-3.2	2.60 V	309	56.60	-5.80
3	*2437.00	119.5 PK			2.86 V	301	125.13	-5.63
4	*2437.00	109.6 AV			2.86 V	301	115.23	-5.63
5	2483.50	68.6 PK	74.0	-5.4	2.60 V	302	74.08	-5.48
6	2483.50	51.4 AV	54.0	-2.6	2.60 V	302	56.88	-5.48
7	4874.00	63.6 PK	74.0	-10.4	2.37 V	294	63.33	0.27
8	4874.00	50.5 AV	54.0	-3.5	2.37 V	294	50.23	0.27
9	7311.00	51.7 PK	74.0	-22.3	2.32 V	303	44.93	6.77
10	7311.00	41.5 AV	54.0	-12.5	2.32 V	303	34.73	6.77

**REMARKS:**

1. Emission Level(dBuV/m) = Raw Value(dBuV) + Correction Factor(dB/m)
2. Correction Factor(dB/m) = Antenna Factor(dB/m) + Cable Factor(dB) – Pre-Amplifier Factor(dB)
3. The other emission levels were very low against the limit.
4. Margin value = Emission Level – Limit value
5. " \* ": Fundamental frequency.

<b>CHANNEL</b>	TX Channel 11	<b>DETECTOR FUNCTION</b>	Peak (PK)
<b>FREQUENCY RANGE</b>	1GHz ~ 25GHz		Average (AV)

**ANTENNA POLARITY & TEST DISTANCE: HORIZONTAL AT 3 M**

NO.	FREQ. (MHz)	EMISSION LEVEL (dBuV/m)	LIMIT (dBuV/m)	MARGIN (dB)	ANTENNA HEIGHT (m)	TABLE ANGLE (Degree)	RAW VALUE (dBuV)	CORRECTION FACTOR (dB/m)
1	*2462.00	107.7 PK			1.26 H	207	113.25	-5.55
2	*2462.00	96.5 AV			1.26 H	207	102.05	-5.55
3	2483.50	66.6 PK	74.0	-7.4	1.26 H	207	72.08	-5.48
4	2483.50	46.0 AV	54.0	-8.0	1.26 H	207	51.48	-5.48
5	4924.00	48.9 PK	74.0	-25.1	1.06 H	239	48.52	0.38
6	4924.00	44.9 AV	54.0	-9.1	1.06 H	239	44.52	0.38
7	7386.00	52.0 PK	74.0	-22.0	1.11 H	261	45.08	6.92
8	7386.00	41.8 AV	54.0	-12.2	1.11 H	261	34.88	6.92

**ANTENNA POLARITY & TEST DISTANCE: VERTICAL AT 3 M**

NO.	FREQ. (MHz)	EMISSION LEVEL (dBuV/m)	LIMIT (dBuV/m)	MARGIN (dB)	ANTENNA HEIGHT (m)	TABLE ANGLE (Degree)	RAW VALUE (dBuV)	CORRECTION FACTOR (dB/m)
1	*2462.00	114.9 PK			3.05 V	302	120.45	-5.55
2	*2462.00	104.2 AV			3.05 V	302	109.75	-5.55
<b>3</b>	<b>2483.50</b>	<b>73.9 PK</b>	<b>74.0</b>	<b>-0.1</b>	<b>3.05 V</b>	<b>302</b>	<b>79.38</b>	<b>-5.48</b>
4	2483.50	53.6 AV	54.0	-0.4	3.05 V	302	59.08	-5.48
5	4924.00	49.6 PK	74.0	-24.4	2.37 V	279	49.22	0.38
6	4924.00	45.5 AV	54.0	-8.5	2.37 V	279	45.12	0.38
7	7386.00	51.8 PK	74.0	-22.2	2.45 V	306	44.88	6.92
8	7386.00	41.5 AV	54.0	-12.5	2.45 V	306	34.58	6.92

**REMARKS:**

1. Emission Level(dBuV/m) = Raw Value(dBuV) + Correction Factor(dB/m)
2. Correction Factor(dB/m) = Antenna Factor(dB/m) + Cable Factor(dB) – Pre-Amplifier Factor(dB)
3. The other emission levels were very low against the limit.
4. Margin value = Emission Level – Limit value
5. " \* ": Fundamental frequency.

**802.11n (HT20)**

<b>CHANNEL</b>	TX Channel 1	<b>DETECTOR FUNCTION</b>	Peak (PK)
<b>FREQUENCY RANGE</b>	1GHz ~ 25GHz		Average (AV)

<b>ANTENNA POLARITY &amp; TEST DISTANCE: HORIZONTAL AT 3 M</b>								
<b>NO.</b>	<b>FREQ. (MHz)</b>	<b>EMISSION LEVEL (dBuV/m)</b>	<b>LIMIT (dBuV/m)</b>	<b>MARGIN (dB)</b>	<b>ANTENNA HEIGHT (m)</b>	<b>TABLE ANGLE (Degree)</b>	<b>RAW VALUE (dBuV)</b>	<b>CORRECTION FACTOR (dB/m)</b>
1	2390.00	66.4 PK	74.0	-7.6	1.31 H	201	72.20	-5.80
2	2390.00	42.8 AV	54.0	-11.2	1.31 H	201	48.60	-5.80
3	*2412.00	105.9 PK			1.31 H	201	111.62	-5.72
4	*2412.00	94.2 AV			1.31 H	201	99.92	-5.72
5	4824.00	49.5 PK	74.0	-24.5	1.06 H	254	49.40	0.10
6	4824.00	45.2 AV	54.0	-8.8	1.06 H	254	45.10	0.10

<b>ANTENNA POLARITY &amp; TEST DISTANCE: VERTICAL AT 3 M</b>								
<b>NO.</b>	<b>FREQ. (MHz)</b>	<b>EMISSION LEVEL (dBuV/m)</b>	<b>LIMIT (dBuV/m)</b>	<b>MARGIN (dB)</b>	<b>ANTENNA HEIGHT (m)</b>	<b>TABLE ANGLE (Degree)</b>	<b>RAW VALUE (dBuV)</b>	<b>CORRECTION FACTOR (dB/m)</b>
1	2390.00	73.7 PK	74.0	-0.3	3.08 V	292	79.50	-5.80
2	2390.00	50.8 AV	54.0	-3.2	3.08 V	292	56.60	-5.80
3	*2412.00	113.1 PK			3.08 V	292	118.82	-5.72
4	*2412.00	101.9 AV			3.08 V	292	107.62	-5.72
5	4824.00	48.7 PK	74.0	-25.3	2.31 V	293	48.60	0.10
6	4824.00	44.4 AV	54.0	-9.6	2.31 V	293	44.30	0.10

**REMARKS:**

1. Emission Level(dBuV/m) = Raw Value(dBuV) + Correction Factor(dB/m)
2. Correction Factor(dB/m) = Antenna Factor(dB/m) + Cable Factor(dB) – Pre-Amplifier Factor(dB)
3. The other emission levels were very low against the limit.
4. Margin value = Emission Level – Limit value
5. " \* ": Fundamental frequency.



<b>CHANNEL</b>	TX Channel 6	<b>DETECTOR FUNCTION</b>	Peak (PK)
<b>FREQUENCY RANGE</b>	1GHz ~ 25GHz		Average (AV)

**ANTENNA POLARITY & TEST DISTANCE: HORIZONTAL AT 3 M**

NO.	FREQ. (MHz)	EMISSION LEVEL (dBuV/m)	LIMIT (dBuV/m)	MARGIN (dB)	ANTENNA HEIGHT (m)	TABLE ANGLE (Degree)	RAW VALUE (dBuV)	CORRECTION FACTOR (dB/m)
1	2390.00	62.8 PK	74.0	-11.2	1.30 H	197	68.60	-5.80
2	2390.00	45.4 AV	54.0	-8.6	1.30 H	197	51.20	-5.80
3	*2437.00	112.7 PK			1.30 H	197	118.33	-5.63
4	*2437.00	101.2 AV			1.30 H	197	106.83	-5.63
5	2483.50	65.1 PK	74.0	-8.9	1.30 H	197	70.58	-5.48
6	2483.50	46.1 AV	54.0	-7.9	1.30 H	197	51.58	-5.48
7	4874.00	50.2 PK	74.0	-23.8	1.06 H	222	49.93	0.27
8	4874.00	46.2 AV	54.0	-7.8	1.06 H	222	45.93	0.27
9	7311.00	49.4 PK	74.0	-24.6	1.17 H	265	42.63	6.77
10	7311.00	43.1 AV	54.0	-10.9	1.17 H	265	36.33	6.77

**ANTENNA POLARITY & TEST DISTANCE: VERTICAL AT 3 M**

NO.	FREQ. (MHz)	EMISSION LEVEL (dBuV/m)	LIMIT (dBuV/m)	MARGIN (dB)	ANTENNA HEIGHT (m)	TABLE ANGLE (Degree)	RAW VALUE (dBuV)	CORRECTION FACTOR (dB/m)
1	2390.00	70.0 PK	74.0	-4.0	2.94 V	303	75.80	-5.80
2	2390.00	52.6 AV	54.0	-1.4	2.94 V	303	58.40	-5.80
3	*2437.00	119.9 PK			2.83 V	307	125.53	-5.63
4	*2437.00	108.9 AV			2.83 V	307	114.53	-5.63
5	2483.50	72.1 PK	74.0	-1.9	2.75 V	308	77.58	-5.48
6	2483.50	53.0 AV	54.0	-1.0	2.75 V	308	58.48	-5.48
7	4874.00	63.4 PK	74.0	-10.6	2.30 V	295	63.13	0.27
8	4874.00	50.2 AV	54.0	-3.8	2.30 V	295	49.93	0.27
9	7311.00	52.5 PK	74.0	-21.5	2.39 V	315	45.73	6.77
10	7311.00	41.8 AV	54.0	-12.2	2.39 V	315	35.03	6.77

**REMARKS:**

1. Emission Level(dBuV/m) = Raw Value(dBuV) + Correction Factor(dB/m)
2. Correction Factor(dB/m) = Antenna Factor(dB/m) + Cable Factor(dB) – Pre-Amplifier Factor(dB)
3. The other emission levels were very low against the limit.
4. Margin value = Emission Level – Limit value
5. " \* ": Fundamental frequency.

<b>CHANNEL</b>	TX Channel 11	<b>DETECTOR FUNCTION</b>	Peak (PK)
<b>FREQUENCY RANGE</b>	1GHz ~ 25GHz		Average (AV)

**ANTENNA POLARITY & TEST DISTANCE: HORIZONTAL AT 3 M**

NO.	FREQ. (MHz)	EMISSION LEVEL (dBuV/m)	LIMIT (dBuV/m)	MARGIN (dB)	ANTENNA HEIGHT (m)	TABLE ANGLE (Degree)	RAW VALUE (dBuV)	CORRECTION FACTOR (dB/m)
1	*2462.00	104.8 PK			1.34 H	196	110.35	-5.55
2	*2462.00	94.1 AV			1.34 H	196	99.65	-5.55
3	2483.50	66.6 PK	74.0	-7.4	1.34 H	196	72.08	-5.48
4	2483.50	46.6 AV	54.0	-7.4	1.34 H	196	52.08	-5.48
5	4924.00	49.5 PK	74.0	-24.5	1.08 H	231	49.12	0.38
6	4924.00	45.3 AV	54.0	-8.7	1.08 H	231	44.92	0.38
7	7386.00	49.4 PK	74.0	-24.6	1.18 H	241	42.48	6.92
8	7386.00	43.4 AV	54.0	-10.6	1.18 H	241	36.48	6.92

**ANTENNA POLARITY & TEST DISTANCE: VERTICAL AT 3 M**

NO.	FREQ. (MHz)	EMISSION LEVEL (dBuV/m)	LIMIT (dBuV/m)	MARGIN (dB)	ANTENNA HEIGHT (m)	TABLE ANGLE (Degree)	RAW VALUE (dBuV)	CORRECTION FACTOR (dB/m)
1	*2462.00	112.0 PK			3.02 V	300	117.55	-5.55
2	*2462.00	101.8 AV			3.02 V	300	107.35	-5.55
3	2483.50	73.7 PK	74.0	-0.3	3.02 V	300	79.18	-5.48
4	2483.50	53.7 AV	54.0	-0.3	3.02 V	300	59.18	-5.48
5	4924.00	49.1 PK	74.0	-24.9	2.40 V	283	48.72	0.38
6	4924.00	44.5 AV	54.0	-9.5	2.40 V	283	44.12	0.38
7	7386.00	51.4 PK	74.0	-22.6	2.35 V	318	44.48	6.92
8	7386.00	41.5 AV	54.0	-12.5	2.35 V	318	34.58	6.92

**REMARKS:**

1. Emission Level(dBuV/m) = Raw Value(dBuV) + Correction Factor(dB/m)
2. Correction Factor(dB/m) = Antenna Factor(dB/m) + Cable Factor(dB) – Pre-Amplifier Factor(dB)
3. The other emission levels were very low against the limit.
4. Margin value = Emission Level – Limit value
5. " \* ": Fundamental frequency.

**1TX Mode**
**802.11b**

<b>CHANNEL</b>	TX Channel 1	<b>DETECTOR FUNCTION</b>	Peak (PK)
<b>FREQUENCY RANGE</b>	1GHz ~ 25GHz		Average (AV)

**ANTENNA POLARITY & TEST DISTANCE: HORIZONTAL AT 3 M**

NO.	FREQ. (MHz)	EMISSION LEVEL (dBuV/m)	LIMIT (dBuV/m)	MARGIN (dB)	ANTENNA HEIGHT (m)	TABLE ANGLE (Degree)	RAW VALUE (dBuV)	CORRECTION FACTOR (dB/m)
1	2390.00	46.8 PK	74.0	-27.2	1.09 H	65	52.60	-5.80
2	2390.00	34.2 AV	54.0	-19.8	1.09 H	65	40.00	-5.80
3	*2412.00	103.8 PK			1.09 H	65	109.52	-5.72
4	*2412.00	100.7 AV			1.09 H	65	106.42	-5.72
5	4824.00	48.4 PK	74.0	-25.6	1.11 H	228	48.30	0.10
6	4824.00	44.6 AV	54.0	-9.4	1.11 H	228	44.50	0.10

**ANTENNA POLARITY & TEST DISTANCE: VERTICAL AT 3 M**

NO.	FREQ. (MHz)	EMISSION LEVEL (dBuV/m)	LIMIT (dBuV/m)	MARGIN (dB)	ANTENNA HEIGHT (m)	TABLE ANGLE (Degree)	RAW VALUE (dBuV)	CORRECTION FACTOR (dB/m)
1	2390.00	49.2 PK	74.0	-24.8	1.11 V	105	55.00	-5.80
2	2390.00	36.6 AV	54.0	-17.4	1.11 V	105	42.40	-5.80
3	*2412.00	107.2 PK			1.11 V	105	112.92	-5.72
4	*2412.00	104.6 AV			1.11 V	105	110.32	-5.72
5	4824.00	55.2 PK	74.0	-18.8	2.44 V	319	55.10	0.10
6	4824.00	53.6 AV	54.0	-0.4	2.44 V	319	53.50	0.10

**REMARKS:**

1. Emission Level(dBuV/m) = Raw Value(dBuV) + Correction Factor(dB/m)
2. Correction Factor(dB/m) = Antenna Factor(dB/m) + Cable Factor(dB) – Pre-Amplifier Factor(dB)
3. The other emission levels were very low against the limit.
4. Margin value = Emission Level – Limit value
5. " \* ": Fundamental frequency.

<b>CHANNEL</b>	TX Channel 6	<b>DETECTOR FUNCTION</b>	Peak (PK)
<b>FREQUENCY RANGE</b>	1GHz ~ 25GHz		Average (AV)

**ANTENNA POLARITY & TEST DISTANCE: HORIZONTAL AT 3 M**

NO.	FREQ. (MHz)	EMISSION LEVEL (dBuV/m)	LIMIT (dBuV/m)	MARGIN (dB)	ANTENNA HEIGHT (m)	TABLE ANGLE (Degree)	RAW VALUE (dBuV)	CORRECTION FACTOR (dB/m)
1	2390.00	45.8 PK	74.0	-28.2	1.09 H	65	51.60	-5.80
2	2390.00	32.9 AV	54.0	-21.1	1.09 H	65	38.70	-5.80
3	*2437.00	104.1 PK			1.14 H	65	109.73	-5.63
4	*2437.00	100.9 AV			1.14 H	65	106.53	-5.63
5	2483.50	49.5 PK	74.0	-24.5	1.09 H	65	54.98	-5.48
6	2483.50	36.2 AV	54.0	-17.8	1.09 H	65	41.68	-5.48
7	4874.00	48.0 PK	74.0	-26.0	1.00 H	244	47.73	0.27
8	4874.00	44.2 AV	54.0	-9.8	1.00 H	244	43.93	0.27
9	7311.00	50.8 PK	74.0	-23.2	1.00 H	251	44.03	6.77
10	7311.00	42.9 AV	54.0	-11.1	1.00 H	251	36.13	6.77

**ANTENNA POLARITY & TEST DISTANCE: VERTICAL AT 3 M**

NO.	FREQ. (MHz)	EMISSION LEVEL (dBuV/m)	LIMIT (dBuV/m)	MARGIN (dB)	ANTENNA HEIGHT (m)	TABLE ANGLE (Degree)	RAW VALUE (dBuV)	CORRECTION FACTOR (dB/m)
1	2390.00	48.1 PK	74.0	-25.9	1.42 V	101	53.90	-5.80
2	2390.00	35.3 AV	54.0	-18.7	1.42 V	101	41.10	-5.80
3	*2437.00	107.5 PK			1.42 V	101	113.13	-5.63
4	*2437.00	104.8 AV			1.42 V	101	110.43	-5.63
5	2483.50	51.8 PK	74.0	-22.2	1.42 V	101	57.28	-5.48
6	2483.50	38.6 AV	54.0	-15.4	1.42 V	101	44.08	-5.48
7	4874.00	55.1 PK	74.0	-18.9	2.52 V	317	54.83	0.27
8	4874.00	53.3 AV	54.0	-0.7	2.52 V	317	53.03	0.27
9	7311.00	55.8 PK	74.0	-18.2	2.53 V	293	49.03	6.77
10	7311.00	51.0 AV	54.0	-3.0	2.53 V	293	44.23	6.77

**REMARKS:**

1. Emission Level(dBuV/m) = Raw Value(dBuV) + Correction Factor(dB/m)
2. Correction Factor(dB/m) = Antenna Factor(dB/m) + Cable Factor(dB) – Pre-Amplifier Factor(dB)
3. The other emission levels were very low against the limit.
4. Margin value = Emission Level – Limit value
5. " \* ": Fundamental frequency.



<b>CHANNEL</b>	TX Channel 11	<b>DETECTOR FUNCTION</b>	Peak (PK)
<b>FREQUENCY RANGE</b>	1GHz ~ 25GHz		Average (AV)

**ANTENNA POLARITY & TEST DISTANCE: HORIZONTAL AT 3 M**

NO.	FREQ. (MHz)	EMISSION LEVEL (dBuV/m)	LIMIT (dBuV/m)	MARGIN (dB)	ANTENNA HEIGHT (m)	TABLE ANGLE (Degree)	RAW VALUE (dBuV)	CORRECTION FACTOR (dB/m)
1	*2462.00	104.9 PK			1.17 H	66	110.45	-5.55
2	*2462.00	102.1 AV			1.17 H	66	107.65	-5.55
3	2500.00	50.8 PK	74.0	-23.2	1.17 H	66	56.23	-5.43
4	2500.00	37.9 AV	54.0	-16.1	1.17 H	66	43.33	-5.43
5	4924.00	48.5 PK	74.0	-25.5	1.00 H	252	48.12	0.38
6	4924.00	44.8 AV	54.0	-9.2	1.00 H	252	44.42	0.38
7	7386.00	50.2 PK	74.0	-23.8	1.00 H	239	43.28	6.92
8	7386.00	42.6 AV	54.0	-11.4	1.00 H	239	35.68	6.92

**ANTENNA POLARITY & TEST DISTANCE: VERTICAL AT 3 M**

NO.	FREQ. (MHz)	EMISSION LEVEL (dBuV/m)	LIMIT (dBuV/m)	MARGIN (dB)	ANTENNA HEIGHT (m)	TABLE ANGLE (Degree)	RAW VALUE (dBuV)	CORRECTION FACTOR (dB/m)
1	*2462.00	108.3 PK			1.09 V	98	113.85	-5.55
2	*2462.00	105.6 AV			1.09 V	98	111.15	-5.55
3	2500.00	53.2 PK	74.0	-20.8	1.09 V	98	58.63	-5.43
4	2500.00	40.4 AV	54.0	-13.6	1.09 V	98	45.83	-5.43
5	4924.00	55.4 PK	74.0	-18.6	2.49 V	311	55.02	0.38
<b>6</b>	<b>4924.00</b>	<b>53.9 AV</b>	<b>54.0</b>	<b>-0.1</b>	<b>2.49 V</b>	<b>311</b>	<b>53.52</b>	<b>0.38</b>
7	7386.00	55.6 PK	74.0	-18.4	2.17 V	343	48.68	6.92
8	7386.00	50.8 AV	54.0	-3.2	2.17 V	343	43.88	6.92

**REMARKS:**

1. Emission Level(dBuV/m) = Raw Value(dBuV) + Correction Factor(dB/m)
2. Correction Factor(dB/m) = Antenna Factor(dB/m) + Cable Factor(dB) – Pre-Amplifier Factor(dB)
3. The other emission levels were very low against the limit.
4. Margin value = Emission Level – Limit value
5. " \* ": Fundamental frequency.

**802.11g**

<b>CHANNEL</b>	TX Channel 1	<b>DETECTOR FUNCTION</b>	Peak (PK)
<b>FREQUENCY RANGE</b>	1GHz ~ 25GHz		Average (AV)

<b>ANTENNA POLARITY &amp; TEST DISTANCE: HORIZONTAL AT 3 M</b>								
NO.	FREQ. (MHz)	EMISSION LEVEL (dBuV/m)	LIMIT (dBuV/m)	MARGIN (dB)	ANTENNA HEIGHT (m)	TABLE ANGLE (Degree)	RAW VALUE (dBuV)	CORRECTION FACTOR (dB/m)
1	2390.00	63.9 PK	74.0	-10.1	1.10 H	360	69.70	-5.80
2	2390.00	41.6 AV	54.0	-12.4	1.10 H	360	47.40	-5.80
3	*2412.00	100.6 PK			1.10 H	360	106.32	-5.72
4	*2412.00	90.9 AV			1.10 H	360	96.62	-5.72
5	4824.00	49.3 PK	74.0	-24.7	1.15 H	240	49.20	0.10
6	4824.00	45.3 AV	54.0	-8.7	1.15 H	240	45.20	0.10

<b>ANTENNA POLARITY &amp; TEST DISTANCE: VERTICAL AT 3 M</b>								
NO.	FREQ. (MHz)	EMISSION LEVEL (dBuV/m)	LIMIT (dBuV/m)	MARGIN (dB)	ANTENNA HEIGHT (m)	TABLE ANGLE (Degree)	RAW VALUE (dBuV)	CORRECTION FACTOR (dB/m)
<b>1</b>	<b>2390.00</b>	<b>73.9 PK</b>	<b>74.0</b>	<b>-0.1</b>	<b>2.44 V</b>	<b>315</b>	<b>79.70</b>	<b>-5.80</b>
2	2390.00	51.3 AV	54.0	-2.7	2.44 V	315	57.10	-5.80
3	*2412.00	110.9 PK			2.44 V	315	116.62	-5.72
4	*2412.00	101.1 AV			2.44 V	315	106.82	-5.72
5	4824.00	49.9 PK	74.0	-24.1	1.31 V	255	49.80	0.10
6	4824.00	45.5 AV	54.0	-8.5	1.31 V	255	45.40	0.10

**REMARKS:**

1. Emission Level(dBuV/m) = Raw Value(dBuV) + Correction Factor(dB/m)
2. Correction Factor(dB/m) = Antenna Factor(dB/m) + Cable Factor(dB) – Pre-Amplifier Factor(dB)
3. The other emission levels were very low against the limit.
4. Margin value = Emission Level – Limit value
5. " \* ": Fundamental frequency.

<b>CHANNEL</b>	TX Channel 6	<b>DETECTOR FUNCTION</b>	Peak (PK)
<b>FREQUENCY RANGE</b>	1GHz ~ 25GHz		Average (AV)

**ANTENNA POLARITY & TEST DISTANCE: HORIZONTAL AT 3 M**

NO.	FREQ. (MHz)	EMISSION LEVEL (dBuV/m)	LIMIT (dBuV/m)	MARGIN (dB)	ANTENNA HEIGHT (m)	TABLE ANGLE (Degree)	RAW VALUE (dBuV)	CORRECTION FACTOR (dB/m)
1	2390.00	54.2 PK	74.0	-19.8	1.09 H	360	60.00	-5.80
2	2390.00	35.7 AV	54.0	-18.3	1.09 H	360	41.50	-5.80
3	*2437.00	104.5 PK			1.09 H	360	110.13	-5.63
4	*2437.00	94.3 AV			1.09 H	360	99.93	-5.63
5	2483.50	54.5 PK	74.0	-19.5	1.09 H	360	59.98	-5.48
6	2483.50	37.5 AV	54.0	-16.5	1.09 H	360	42.98	-5.48
7	4874.00	50.4 PK	74.0	-23.6	1.00 H	244	50.13	0.27
8	4874.00	46.0 AV	54.0	-8.0	1.00 H	244	45.73	0.27
9	7311.00	49.6 PK	74.0	-24.4	1.11 H	243	42.83	6.77
10	7311.00	43.4 AV	54.0	-10.6	1.11 H	243	36.63	6.77

**ANTENNA POLARITY & TEST DISTANCE: VERTICAL AT 3 M**

NO.	FREQ. (MHz)	EMISSION LEVEL (dBuV/m)	LIMIT (dBuV/m)	MARGIN (dB)	ANTENNA HEIGHT (m)	TABLE ANGLE (Degree)	RAW VALUE (dBuV)	CORRECTION FACTOR (dB/m)
1	2390.00	64.7 PK	74.0	-9.3	2.34 V	328	70.50	-5.80
2	2390.00	45.9 AV	54.0	-8.1	2.34 V	328	51.70	-5.80
3	*2437.00	114.2 PK			2.34 V	328	119.83	-5.63
4	*2437.00	104.2 AV			2.34 V	328	109.83	-5.63
5	2483.50	64.4 PK	74.0	-9.6	2.34 V	328	69.88	-5.48
6	2483.50	47.5 AV	54.0	-6.5	2.34 V	328	52.98	-5.48
7	4874.00	49.4 PK	74.0	-24.6	2.37 V	294	49.13	0.27
8	4874.00	45.0 AV	54.0	-9.0	2.37 V	294	44.73	0.27
9	7311.00	51.7 PK	74.0	-22.3	2.36 V	309	44.93	6.77
10	7311.00	41.5 AV	54.0	-12.5	2.36 V	309	34.73	6.77

**REMARKS:**

1. Emission Level(dBuV/m) = Raw Value(dBuV) + Correction Factor(dB/m)
2. Correction Factor(dB/m) = Antenna Factor(dB/m) + Cable Factor(dB) – Pre-Amplifier Factor(dB)
3. The other emission levels were very low against the limit.
4. Margin value = Emission Level – Limit value
5. " \* ": Fundamental frequency.

<b>CHANNEL</b>	TX Channel 11	<b>DETECTOR FUNCTION</b>	Peak (PK)
<b>FREQUENCY RANGE</b>	1GHz ~ 25GHz		Average (AV)

**ANTENNA POLARITY & TEST DISTANCE: HORIZONTAL AT 3 M**

NO.	FREQ. (MHz)	EMISSION LEVEL (dBuV/m)	LIMIT (dBuV/m)	MARGIN (dB)	ANTENNA HEIGHT (m)	TABLE ANGLE (Degree)	RAW VALUE (dBuV)	CORRECTION FACTOR (dB/m)
1	*2462.00	100.0 PK			1.10 H	358	105.55	-5.55
2	*2462.00	89.9 AV			1.10 H	358	95.45	-5.55
3	2483.50	63.1 PK	74.0	-10.9	1.10 H	358	68.58	-5.48
4	2483.50	43.3 AV	54.0	-10.7	1.10 H	358	48.78	-5.48
5	4924.00	49.5 PK	74.0	-24.5	1.08 H	239	49.12	0.38
6	4924.00	45.3 AV	54.0	-8.7	1.08 H	239	44.92	0.38
7	7386.00	51.7 PK	74.0	-22.3	1.11 H	264	44.78	6.92
8	7386.00	41.6 AV	54.0	-12.4	1.11 H	264	34.68	6.92

**ANTENNA POLARITY & TEST DISTANCE: VERTICAL AT 3 M**

NO.	FREQ. (MHz)	EMISSION LEVEL (dBuV/m)	LIMIT (dBuV/m)	MARGIN (dB)	ANTENNA HEIGHT (m)	TABLE ANGLE (Degree)	RAW VALUE (dBuV)	CORRECTION FACTOR (dB/m)
1	*2462.00	110.3 PK			2.34 V	341	115.85	-5.55
2	*2462.00	100.4 AV			2.34 V	341	105.95	-5.55
3	2483.50	73.5 PK	74.0	-0.5	2.34 V	341	78.98	-5.48
4	2483.50	53.4 AV	54.0	-0.6	2.34 V	341	58.88	-5.48
5	4924.00	49.7 PK	74.0	-24.3	2.32 V	279	49.32	0.38
6	4924.00	45.5 AV	54.0	-8.5	2.32 V	279	45.12	0.38
7	7386.00	51.6 PK	74.0	-22.4	2.40 V	311	44.68	6.92
8	7386.00	41.3 AV	54.0	-12.7	2.40 V	311	34.38	6.92

**REMARKS:**

1. Emission Level(dBuV/m) = Raw Value(dBuV) + Correction Factor(dB/m)
2. Correction Factor(dB/m) = Antenna Factor(dB/m) + Cable Factor(dB) – Pre-Amplifier Factor(dB)
3. The other emission levels were very low against the limit.
4. Margin value = Emission Level – Limit value
5. " \* ": Fundamental frequency.



**802.11n (HT20)**

<b>CHANNEL</b>	TX Channel 1	<b>DETECTOR FUNCTION</b>	Peak (PK)
<b>FREQUENCY RANGE</b>	1GHz ~ 25GHz		Average (AV)

<b>ANTENNA POLARITY &amp; TEST DISTANCE: HORIZONTAL AT 3 M</b>								
NO.	FREQ. (MHz)	EMISSION LEVEL (dBuV/m)	LIMIT (dBuV/m)	MARGIN (dB)	ANTENNA HEIGHT (m)	TABLE ANGLE (Degree)	RAW VALUE (dBuV)	CORRECTION FACTOR (dB/m)
1	2390.00	63.3 PK	74.0	-10.7	1.13 H	359	69.10	-5.80
2	2390.00	40.1 AV	54.0	-13.9	1.13 H	359	45.90	-5.80
3	*2412.00	99.4 PK			1.13 H	359	105.12	-5.72
4	*2412.00	88.7 AV			1.13 H	359	94.42	-5.72
5	4824.00	49.2 PK	74.0	-24.8	1.12 H	242	49.10	0.10
6	4824.00	45.0 AV	54.0	-9.0	1.12 H	242	44.90	0.10

<b>ANTENNA POLARITY &amp; TEST DISTANCE: VERTICAL AT 3 M</b>								
NO.	FREQ. (MHz)	EMISSION LEVEL (dBuV/m)	LIMIT (dBuV/m)	MARGIN (dB)	ANTENNA HEIGHT (m)	TABLE ANGLE (Degree)	RAW VALUE (dBuV)	CORRECTION FACTOR (dB/m)
1	2390.00	73.5 PK	74.0	-0.5	2.49 V	313	79.30	-5.80
2	2390.00	50.5 AV	54.0	-3.5	2.49 V	313	56.30	-5.80
3	*2412.00	109.6 PK			2.49 V	313	115.32	-5.72
4	*2412.00	98.7 AV			2.49 V	313	104.42	-5.72
5	4824.00	49.0 PK	74.0	-25.0	2.35 V	289	48.90	0.10
6	4824.00	44.7 AV	54.0	-9.3	2.35 V	289	44.60	0.10

**REMARKS:**

1. Emission Level(dBuV/m) = Raw Value(dBuV) + Correction Factor(dB/m)
2. Correction Factor(dB/m) = Antenna Factor(dB/m) + Cable Factor(dB) – Pre-Amplifier Factor(dB)
3. The other emission levels were very low against the limit.
4. Margin value = Emission Level – Limit value
5. " \* ": Fundamental frequency.

<b>CHANNEL</b>	TX Channel 6	<b>DETECTOR FUNCTION</b>	Peak (PK)
<b>FREQUENCY RANGE</b>	1GHz ~ 25GHz		Average (AV)

**ANTENNA POLARITY & TEST DISTANCE: HORIZONTAL AT 3 M**

NO.	FREQ. (MHz)	EMISSION LEVEL (dBuV/m)	LIMIT (dBuV/m)	MARGIN (dB)	ANTENNA HEIGHT (m)	TABLE ANGLE (Degree)	RAW VALUE (dBuV)	CORRECTION FACTOR (dB/m)
1	2390.00	53.5 PK	74.0	-20.5	1.15 H	352	59.30	-5.80
2	2390.00	37.1 AV	54.0	-16.9	1.15 H	352	42.90	-5.80
3	*2437.00	103.8 PK			1.15 H	352	109.43	-5.63
4	*2437.00	92.9 AV			1.15 H	352	98.53	-5.63
5	2483.50	55.2 PK	74.0	-18.8	1.15 H	352	60.68	-5.48
6	2483.50	37.7 AV	54.0	-16.3	1.15 H	352	43.18	-5.48
7	4874.00	49.7 PK	74.0	-24.3	1.05 H	230	49.43	0.27
8	4874.00	45.7 AV	54.0	-8.3	1.05 H	230	45.43	0.27
9	7311.00	48.8 PK	74.0	-25.2	1.14 H	266	42.03	6.77
10	7311.00	42.8 AV	54.0	-11.2	1.14 H	266	36.03	6.77

**ANTENNA POLARITY & TEST DISTANCE: VERTICAL AT 3 M**

NO.	FREQ. (MHz)	EMISSION LEVEL (dBuV/m)	LIMIT (dBuV/m)	MARGIN (dB)	ANTENNA HEIGHT (m)	TABLE ANGLE (Degree)	RAW VALUE (dBuV)	CORRECTION FACTOR (dB/m)
1	2390.00	63.5 PK	74.0	-10.5	2.56 V	337	69.30	-5.80
2	2390.00	46.8 AV	54.0	-7.2	2.56 V	337	52.60	-5.80
3	*2437.00	114.3 PK			2.56 V	337	119.93	-5.63
4	*2437.00	103.2 AV			2.56 V	337	108.83	-5.63
5	2483.50	64.9 PK	74.0	-9.1	2.56 V	337	70.38	-5.48
6	2483.50	47.6 AV	54.0	-6.4	2.56 V	337	53.08	-5.48
7	4874.00	49.8 PK	74.0	-24.2	2.30 V	294	49.53	0.27
8	4874.00	45.3 AV	54.0	-8.7	2.30 V	294	45.03	0.27
9	7311.00	51.8 PK	74.0	-22.2	2.45 V	299	45.03	6.77
10	7311.00	41.3 AV	54.0	-12.7	2.45 V	299	34.53	6.77

**REMARKS:**

1. Emission Level(dBuV/m) = Raw Value(dBuV) + Correction Factor(dB/m)
2. Correction Factor(dB/m) = Antenna Factor(dB/m) + Cable Factor(dB) – Pre-Amplifier Factor(dB)
3. The other emission levels were very low against the limit.
4. Margin value = Emission Level – Limit value
5. " \* ": Fundamental frequency.

<b>CHANNEL</b>	TX Channel 11	<b>DETECTOR FUNCTION</b>	Peak (PK)
<b>FREQUENCY RANGE</b>	1GHz ~ 25GHz		Average (AV)

**ANTENNA POLARITY & TEST DISTANCE: HORIZONTAL AT 3 M**

NO.	FREQ. (MHz)	EMISSION LEVEL (dBuV/m)	LIMIT (dBuV/m)	MARGIN (dB)	ANTENNA HEIGHT (m)	TABLE ANGLE (Degree)	RAW VALUE (dBuV)	CORRECTION FACTOR (dB/m)
1	*2462.00	98.5 PK			1.15 H	360	104.05	-5.55
2	*2462.00	87.9 AV			1.15 H	360	93.45	-5.55
3	2483.50	63.8 PK	74.0	-10.2	1.15 H	360	69.28	-5.48
4	2483.50	44.2 AV	54.0	-9.8	1.15 H	360	49.68	-5.48
5	4924.00	49.5 PK	74.0	-24.5	1.03 H	234	49.12	0.38
6	4924.00	45.2 AV	54.0	-8.8	1.03 H	234	44.82	0.38
7	7386.00	49.5 PK	74.0	-24.5	1.21 H	252	42.58	6.92
8	7386.00	43.6 AV	54.0	-10.4	1.21 H	252	36.68	6.92

**ANTENNA POLARITY & TEST DISTANCE: VERTICAL AT 3 M**

NO.	FREQ. (MHz)	EMISSION LEVEL (dBuV/m)	LIMIT (dBuV/m)	MARGIN (dB)	ANTENNA HEIGHT (m)	TABLE ANGLE (Degree)	RAW VALUE (dBuV)	CORRECTION FACTOR (dB/m)
1	*2462.00	108.8 PK			2.59 V	313	114.35	-5.55
2	*2462.00	97.9 AV			2.59 V	313	103.45	-5.55
3	2483.50	73.6 PK	74.0	-0.4	2.59 V	313	79.08	-5.48
4	<b>2483.50</b>	<b>53.9 AV</b>	<b>54.0</b>	<b>-0.1</b>	<b>2.59 V</b>	<b>313</b>	<b>59.38</b>	<b>-5.48</b>
5	4924.00	49.5 PK	74.0	-24.5	2.36 V	272	49.12	0.38
6	4924.00	45.0 AV	54.0	-9.0	2.36 V	272	44.62	0.38
7	7386.00	51.3 PK	74.0	-22.7	2.38 V	307	44.38	6.92
8	7386.00	41.3 AV	54.0	-12.7	2.38 V	307	34.38	6.92

**REMARKS:**

1. Emission Level(dBuV/m) = Raw Value(dBuV) + Correction Factor(dB/m)
2. Correction Factor(dB/m) = Antenna Factor(dB/m) + Cable Factor(dB) – Pre-Amplifier Factor(dB)
3. The other emission levels were very low against the limit.
4. Margin value = Emission Level – Limit value
5. " \* ": Fundamental frequency.

**Below 1GHz Data:**

**802.11g**

<b>CHANNEL</b>	TX Channel 6	<b>DETECTOR FUNCTION</b>	Quasi-Peak (QP)
<b>FREQUENCY RANGE</b>	Below 1GHz		

**ANTENNA POLARITY & TEST DISTANCE: HORIZONTAL AT 3 M**

NO.	FREQ. (MHz)	EMISSION LEVEL (dBuV/m)	LIMIT (dBuV/m)	MARGIN (dB)	ANTENNA HEIGHT (m)	TABLE ANGLE (Degree)	RAW VALUE (dBuV)	CORRECTION FACTOR (dB/m)
1	39.60	34.3 QP	40.0	-5.7	1.00 H	195	50.10	-15.78
2	90.33	33.8 QP	43.5	-9.7	2.00 H	84	54.70	-20.93
3	250.02	25.9 QP	46.0	-20.1	1.00 H	320	42.03	-16.14
4	400.01	34.8 QP	46.0	-11.2	1.00 H	59	46.55	-11.78
5	600.00	39.6 QP	46.0	-6.4	1.00 H	246	46.39	-6.78
6	1000.00	35.0 QP	54.0	-19.0	1.50 H	232	35.98	-0.99

**ANTENNA POLARITY & TEST DISTANCE: VERTICAL AT 3 M**

NO.	FREQ. (MHz)	EMISSION LEVEL (dBuV/m)	LIMIT (dBuV/m)	MARGIN (dB)	ANTENNA HEIGHT (m)	TABLE ANGLE (Degree)	RAW VALUE (dBuV)	CORRECTION FACTOR (dB/m)
1	30.63	32.9 QP	40.0	-7.1	1.00 V	307	49.40	-16.53
2	74.55	32.7 QP	40.0	-7.3	1.50 V	281	51.54	-18.83
3	106.73	36.9 QP	43.5	-6.6	1.00 V	267	55.32	-18.42
4	250.02	27.1 QP	46.0	-18.9	1.00 V	0	43.25	-16.14
5	354.73	31.4 QP	46.0	-14.6	1.00 V	0	44.48	-13.04
6	999.98	32.5 QP	54.0	-21.5	1.50 V	112	33.53	-0.99

**REMARKS:**

1. Emission Level(dBuV/m) = Raw Value(dBuV) + Correction Factor(dB/m)
2. Correction Factor(dB/m) = Antenna Factor(dB/m) + Cable Factor(dB) – Pre-Amplifier Factor(dB)
3. The other emission levels were very low against the limit.
4. Margin value = Emission Level – Limit value

#### 4.1.8 Test Results (Mode 2)

##### Below 1GHz Data:

##### 802.11g

<b>CHANNEL</b>	TX Channel 6	<b>DETECTOR FUNCTION</b>	Quasi-Peak (QP)
<b>FREQUENCY RANGE</b>	Below 1GHz		

##### ANTENNA POLARITY & TEST DISTANCE: HORIZONTAL AT 3 M

NO.	FREQ. (MHz)	EMISSION LEVEL (dBuV/m)	LIMIT (dBuV/m)	MARGIN (dB)	ANTENNA HEIGHT (m)	TABLE ANGLE (Degree)	RAW VALUE (dBuV)	CORRECTION FACTOR (dB/m)
1	39.42	34.7 QP	40.0	-5.3	1.21 H	100	50.52	-15.80
2	77.22	32.4 QP	40.0	-7.6	2.00 H	19	52.09	-19.73
3	148.10	31.6 QP	43.5	-11.9	2.00 H	44	46.80	-15.22
4	250.02	25.9 QP	46.0	-20.1	1.00 H	320	42.03	-16.14
5	400.01	34.8 QP	46.0	-11.2	1.00 H	59	46.55	-11.78
6	700.00	35.0 QP	46.0	-11.0	2.00 H	105	40.47	-5.51

##### ANTENNA POLARITY & TEST DISTANCE: VERTICAL AT 3 M

NO.	FREQ. (MHz)	EMISSION LEVEL (dBuV/m)	LIMIT (dBuV/m)	MARGIN (dB)	ANTENNA HEIGHT (m)	TABLE ANGLE (Degree)	RAW VALUE (dBuV)	CORRECTION FACTOR (dB/m)
1	30.42	32.4 QP	40.0	-7.6	1.00 V	307	48.92	-16.52
2	39.53	31.7 QP	40.0	-8.3	1.00 V	360	47.53	-15.79
3	68.22	28.5 QP	40.0	-11.5	1.00 V	0	45.89	-17.43
4	98.48	34.1 QP	43.5	-9.4	1.50 V	189	54.09	-19.98
5	354.73	31.4 QP	46.0	-14.6	1.00 V	0	44.48	-13.04
6	400.01	35.5 QP	46.0	-10.6	1.50 V	360	47.23	-11.78
7	600.00	39.0 QP	46.0	-7.0	1.00 V	284	45.82	-6.78

##### REMARKS:

1. Emission Level(dBuV/m) = Raw Value(dBuV) + Correction Factor(dB/m)
2. Correction Factor(dB/m) = Antenna Factor(dB/m) + Cable Factor(dB) – Pre-Amplifier Factor(dB)
3. The other emission levels were very low against the limit.
4. Margin value = Emission Level – Limit value

## 4.2 Conducted Emission Measurement

### 4.2.1 Limits of Conducted Emission Measurement

Frequency (MHz)	Conducted Limit (dBuV)	
	Quasi-peak	Average
0.15 - 0.5	66 - 56	56 - 46
0.50 - 5.0	56	46
5.0 - 30.0	60	50

Note: 1. The lower limit shall apply at the transition frequencies.

2. The limit decreases in line with the logarithm of the frequency in the range of 0.15 to 0.50MHz.

### 4.2.2 Test Instruments

DESCRIPTION & MANUFACTURER	MODEL NO.	SERIAL NO.	CALIBRATED DATE	CALIBRATED UNTIL
Test Receiver R&S	ESCS 30	100375	May 06, 2015	May 05, 2016
Line-Impedance Stabilization Network (for EUT) SCHWARZBECK	NSLK-8127	8127-522	Sep. 01, 2015	Aug. 31, 2016
Line-Impedance Stabilization Network (for Peripheral ) R&S	ENV216	100072	June 11, 2015	June 10, 2016
RF Cable	5D-FB	COCCAB-001	Mar. 09, 2015	Mar. 08, 2016
50 ohms Terminator	N/A	EMC-03	Sep. 23, 2015	Sep. 22, 2016
50 ohms Terminator	N/A	EMC-02	Oct. 01, 2015	Sep. 30, 2016
Software BVADT	BVADT_Cond_ V7.3.7.3	NA	NA	NA

#### Note:

1. The calibration interval of the above test instruments are 12 months and the calibrations are traceable to NML/ROC and NIST/USA.
2. The test was performed in Shielded Room No. C.
- 3 The VCCI Con C Registration No. is C-3611.
- 4 Tested Date: Dec. 17, 2015

#### 4.2.3 Test Procedures

- The EUT was placed 0.4 meters from the conducting wall of the shielded room with EUT being connected to the power mains through a line impedance stabilization network (LISN). Other support units were connected to the power mains through another LISN. The two LISNs provide 50 ohm/ 50uH of coupling impedance for the measuring instrument.
- Both lines of the power mains connected to the EUT were checked for maximum conducted interference.
- The frequency range from 150kHz to 30MHz was searched. Emission levels under (Limit - 20dB) was not recorded.

**NOTE:** The resolution bandwidth and video bandwidth of test receiver is 9kHz for quasi-peak detection (QP) and average detection (AV) at frequency 0.15MHz-30MHz.

#### 4.2.4 Deviation from Test Standard

No deviation.

#### 4.2.5 Test Setup

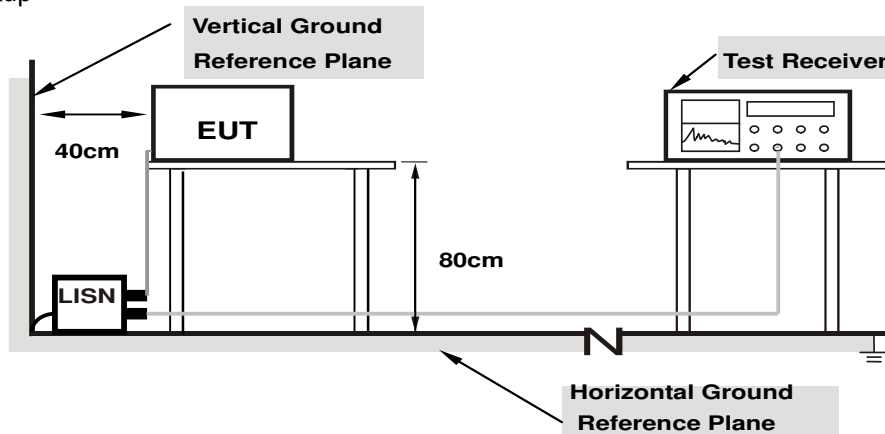

**Note:** 1.Support units were connected to second LISN.

For the actual test configuration, please refer to the attached file (Test Setup Photo).

#### 4.2.6 EUT Operating Conditions

Same as 4.1.6.

4.2.7 Test Results (Mode 1)

Phase	Line (L)	Detector Function	Quasi-Peak (QP) / Average (AV)
-------	----------	-------------------	--------------------------------

No	Freq. [MHz]	Corr.	Reading Value		Emission Level		Limit		Margin	
		Factor (dB)	[dB (uV)]		[dB (uV)]		[dB (uV)]		(dB)	
			Q.P.	AV.	Q.P.	AV.	Q.P.	AV.	Q.P.	AV.
1	0.16172	10.25	28.88	7.39	39.13	17.64	65.38	55.38	-26.24	-37.73
2	0.20078	10.22	22.04	5.00	32.26	15.22	63.58	53.58	-31.32	-38.36
3	0.25547	10.23	21.41	11.43	31.64	21.66	61.58	51.58	-29.94	-29.92
4	0.42344	10.24	30.81	25.71	41.05	35.95	57.38	47.38	-16.33	-11.43
5	0.86484	10.19	12.19	5.10	22.38	15.29	56.00	46.00	-33.62	-30.71
<b>6</b>	<b>18.24219</b>	<b>10.87</b>	<b>34.86</b>	<b>34.16</b>	<b>45.73</b>	<b>45.03</b>	<b>60.00</b>	<b>50.00</b>	<b>-14.27</b>	<b>-4.97</b>
7	24.00000	10.97	33.63	28.96	44.60	39.93	60.00	50.00	-15.40	-10.07

REMARKS:

1. Q.P. and AV. are abbreviations of quasi-peak and average individually.
2. The emission levels of other frequencies were very low against the limit.
3. Margin value = Emission level - Limit value
4. Correction factor = Insertion loss + Cable loss
5. Emission Level = Correction Factor + Reading Value-

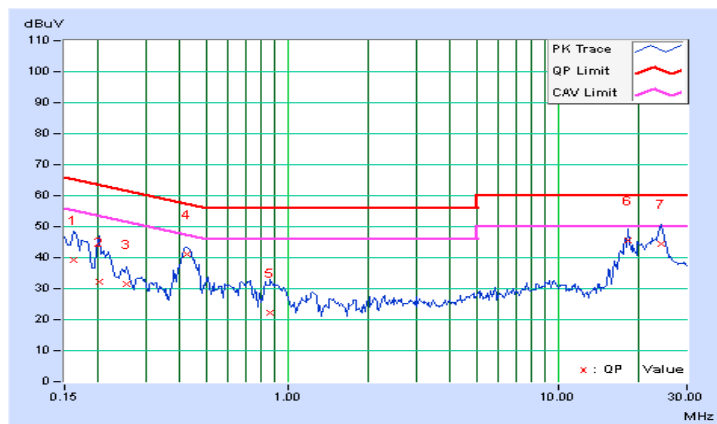



Phase	Neutral (N)	Detector Function	Quasi-Peak (QP) / Average (AV)
-------	-------------	-------------------	--------------------------------

No	Freq. [MHz]	Corr.	Reading Value		Emission Level		Limit		Margin	
		Factor	[dB (uV)]		[dB (uV)]		[dB (uV)]		(dB)	
		(dB)	Q.P.	AV.	Q.P.	AV.	Q.P.	AV.	Q.P.	AV.
1	0.16577	0.16	30.55	9.99	30.71	10.15	65.17	55.17	-34.46	-45.02
2	0.20866	0.16	26.41	16.22	26.57	16.38	63.26	53.26	-36.69	-36.88
3	0.38055	0.18	17.02	1.86	17.20	2.04	58.27	48.27	-41.07	-46.23
4	0.42363	0.18	32.33	27.12	32.51	27.30	57.38	47.38	-24.87	-20.08
5	0.81423	0.21	13.33	3.76	13.54	3.97	56.00	46.00	-42.46	-42.03
6	17.69322	0.80	35.71	35.66	36.51	36.46	60.00	50.00	-23.49	-13.54
7	24.25399	0.99	34.33	29.66	35.32	30.65	60.00	50.00	-24.68	-19.35

**REMARKS:**

1. Q.P. and AV. are abbreviations of quasi-peak and average individually.
2. The emission levels of other frequencies were very low against the limit.
3. Margin value = Emission level - Limit value
4. Correction factor = Insertion loss + Cable loss
5. Emission Level = Correction Factor + Reading Value-

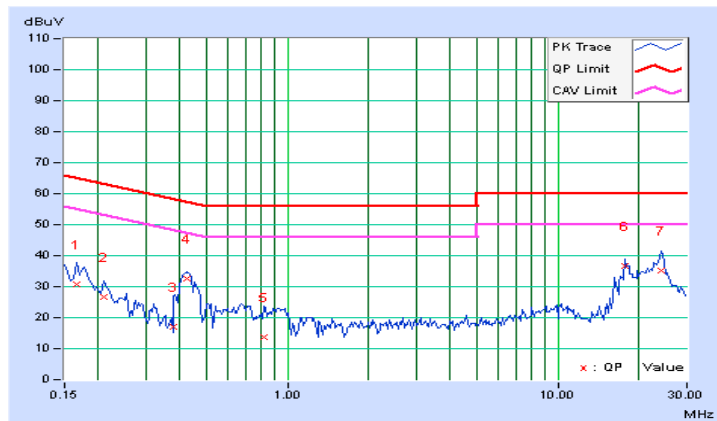

#### 4.2.8 Test Results (Mode 2)

Phase	Line (L)	Detector Function	Quasi-Peak (QP) / Average (AV)
-------	----------	-------------------	--------------------------------

No	Freq. [MHz]	Corr.	Reading Value		Emission Level		Limit		Margin	
		Factor	[dB (uV)]		[dB (uV)]		[dB (uV)]		(dB)	
	(dB)	Q.P.	AV.	Q.P.	AV.	Q.P.	AV.	Q.P.	AV.	
1	0.15391	10.26	31.88	13.59	42.14	23.85	65.79	55.79	-23.65	-31.94
2	0.18984	10.23	38.47	29.27	48.70	39.50	64.04	54.04	-15.35	-14.55
3	0.21641	10.22	26.23	4.04	36.45	14.26	62.96	52.96	-26.50	-38.69
4	0.23594	10.22	31.76	21.79	41.98	32.01	62.24	52.24	-20.25	-20.22
5	0.49766	10.23	21.72	6.09	31.95	16.32	56.04	46.04	-24.09	-29.72
6	19.80078	10.91	27.62	22.56	38.53	33.47	60.00	50.00	-21.47	-16.53
7	23.76172	10.97	34.72	30.03	45.69	41.00	60.00	50.00	-14.31	-9.00

**REMARKS:**

1. Q.P. and AV. are abbreviations of quasi-peak and average individually.
2. The emission levels of other frequencies were very low against the limit.
3. Margin value = Emission level - Limit value
4. Correction factor = Insertion loss + Cable loss
5. Emission Level = Correction Factor + Reading Value-

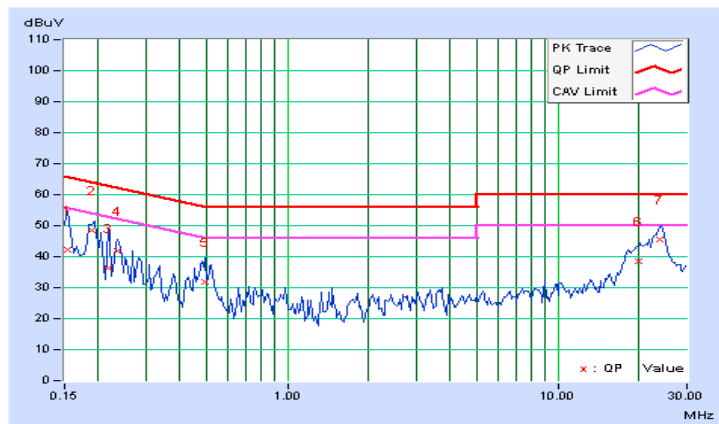

Phase	Neutral (N)	Detector Function	Quasi-Peak (QP) / Average (AV)
-------	-------------	-------------------	--------------------------------

No	Freq. [MHz]	Corr.	Reading Value		Emission Level		Limit		Margin	
		Factor	[dB (uV)]		[dB (uV)]		[dB (uV)]		(dB)	
		(dB)	Q.P.	AV.	Q.P.	AV.	Q.P.	AV.	Q.P.	AV.
1	0.15000	10.24	37.20	22.48	47.44	32.72	66.00	56.00	-18.56	-23.28
2	0.16562	10.23	37.55	12.17	47.78	22.40	65.18	55.18	-17.40	-32.78
3	0.18906	10.21	37.94	28.77	48.15	38.98	64.08	54.08	-15.93	-15.10
4	0.23594	10.20	31.27	21.71	41.47	31.91	62.24	52.24	-20.76	-20.32
5	0.50547	10.21	21.90	9.28	32.11	19.49	56.00	46.00	-23.89	-26.51
6	24.14063	10.99	35.79	31.10	46.78	42.09	60.00	50.00	-13.22	-7.91

**REMARKS:**

1. Q.P. and AV. are abbreviations of quasi-peak and average individually.
2. The emission levels of other frequencies were very low against the limit.
3. Margin value = Emission level - Limit value
4. Correction factor = Insertion loss + Cable loss
5. Emission Level = Correction Factor + Reading Value-

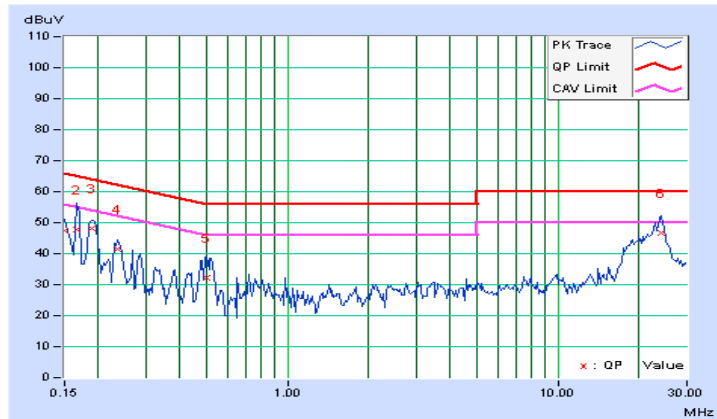

### 4.3 6dB Bandwidth Measurement

#### 4.3.1 Limits of 6dB Bandwidth Measurement

The minimum of 6dB Bandwidth Measurement is 0.5 MHz.

#### 4.3.2 Test Setup

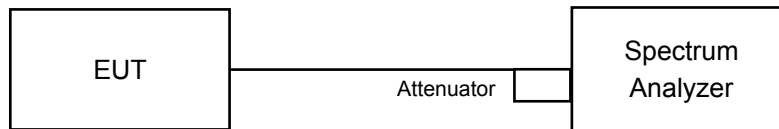

#### 4.3.3 Test Instruments

Refer to section 4.1.2 to get information of above instrument.

#### 4.3.4 Test Procedure

- a. Set resolution bandwidth (RBW) = 100kHz
- b. Set the video bandwidth (VBW)  $\geq 3 \times$  RBW, Detector = Peak.
- c. Trace mode = max hold.
- d. Sweep = auto couple.
- e. Measure the maximum width of the emission that is constrained by the frequencies associated with the two amplitude points (upper and lower) that are attenuated by 6 dB relative to the maximum level measured in the fundamental emission

#### 4.3.5 Deviation from Test Standard

No deviation.

#### 4.3.6 EUT Operating Conditions

The software provided by client to enable the EUT under transmission condition continuously at lowest, middle and highest channel frequencies individually.

#### 4.3.7 Test Result

##### **CDD Mode**

##### **3TX Mode**

##### **802.11b**

Channel	Frequency (MHz)	6dB Bandwidth (MHz)			Minimum Limit (MHz)	Pass / Fail
		Chain 0	Chain 1	Chain 2		
1	2412	8.61	8.59	8.58	0.5	PASS
6	2437	9.05	8.61	9.06	0.5	PASS
11	2462	8.60	9.04	8.59	0.5	PASS

##### **802.11g**

Channel	Frequency (MHz)	6dB Bandwidth (MHz)			Minimum Limit (MHz)	Pass / Fail
		Chain 0	Chain 1	Chain 2		
1	2412	15.83	16.40	15.82	0.5	PASS
6	2437	16.39	15.80	16.38	0.5	PASS
11	2462	16.36	16.39	16.43	0.5	PASS

##### **802.11n (HT20)**

Channel	Frequency (MHz)	6dB Bandwidth (MHz)			Minimum Limit (MHz)	Pass / Fail
		Chain 0	Chain 1	Chain 2		
1	2412	16.45	17.65	17.01	0.5	PASS
6	2437	17.60	17.61	17.63	0.5	PASS
11	2462	17.38	17.65	16.44	0.5	PASS

## Spectrum Plot of Worst Value

## 802.11b / Chain 2 : CH1

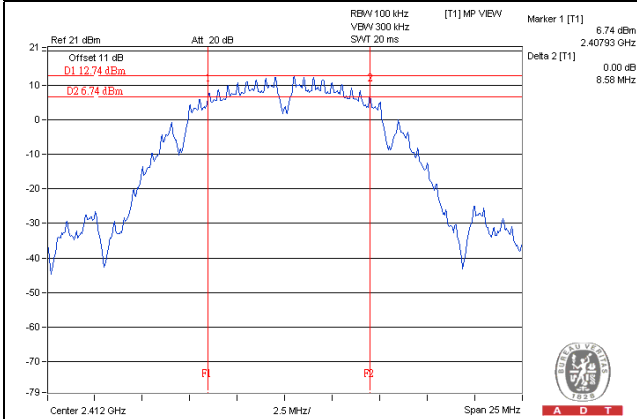

## 802.11g / Chain 1 : CH6

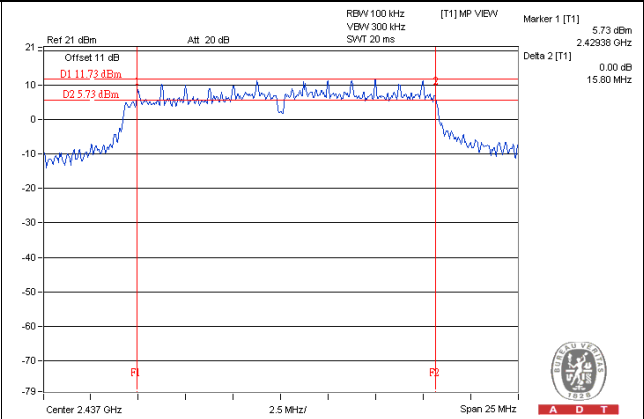

## 802.11n (HT20) / Chain 2 : CH11

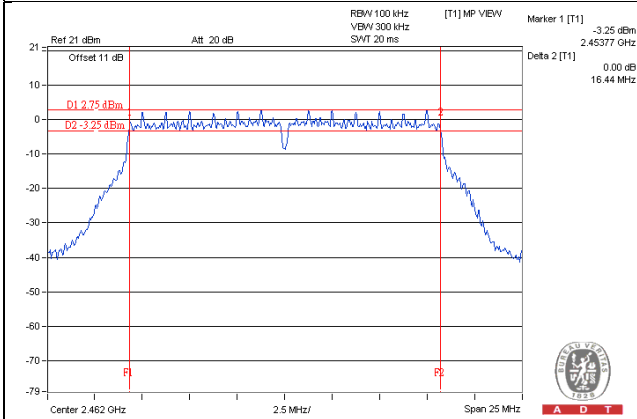

**CDD Mode**
**2TX Mode**
**802.11b**

Channel	Frequency (MHz)	6dB Bandwidth (MHz)		Minimum Limit (MHz)	Pass / Fail
		Chain 0	Chain 1		
1	2412	8.61	8.59	0.5	PASS
6	2437	9.05	8.61	0.5	PASS
11	2462	8.61	9.06	0.5	PASS

**802.11g**

Channel	Frequency (MHz)	6dB Bandwidth (MHz)		Minimum Limit (MHz)	Pass / Fail
		Chain 0	Chain 1		
1	2412	16.34	16.11	0.5	PASS
6	2437	16.39	15.80	0.5	PASS
11	2462	16.38	16.39	0.5	PASS

**802.11n (HT20)**

Channel	Frequency (MHz)	6dB Bandwidth (MHz)		Minimum Limit (MHz)	Pass / Fail
		Chain 0	Chain 1		
1	2412	17.37	17.38	0.5	PASS
6	2437	17.60	17.61	0.5	PASS
11	2462	17.39	17.40	0.5	PASS

### Spectrum Plot of Worst Value

#### 802.11b / Chain 1 : CH1

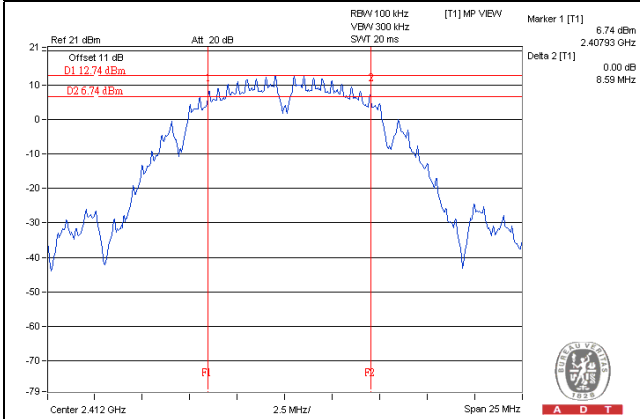

#### 802.11g / Chain 1 : CH6

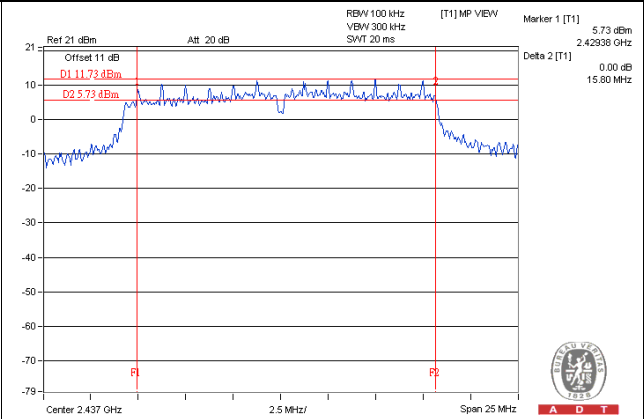

#### 802.11n (HT20) / Chain 0 : CH1

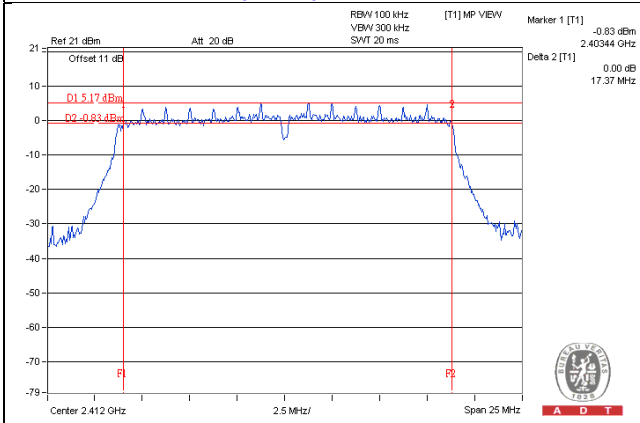



**CDD Mode****1TX Mode****802.11b**

Channel	Frequency (MHz)	6dB Bandwidth (MHz)	Minimum Limit (MHz)	Pass / Fail
1	2412	8.60	0.5	PASS
6	2437	8.58	0.5	PASS
11	2462	8.62	0.5	PASS

**802.11g**

Channel	Frequency (MHz)	6dB Bandwidth (MHz)	Minimum Limit (MHz)	Pass / Fail
1	2412	16.34	0.5	PASS
6	2437	16.39	0.5	PASS
11	2462	16.37	0.5	PASS

**802.11n (HT20)**

Channel	Frequency (MHz)	6dB Bandwidth (MHz)	Minimum Limit (MHz)	Pass / Fail
1	2412	17.37	0.5	PASS
6	2437	17.60	0.5	PASS
11	2462	17.41	0.5	PASS

### Spectrum Plot of Worst Value

#### 802.11b / CH6

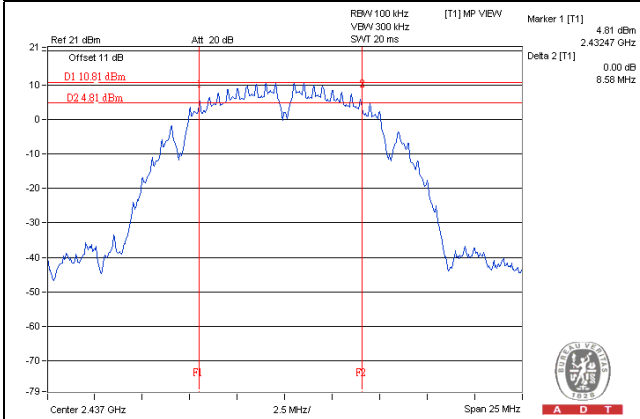

#### 802.11g / CH1

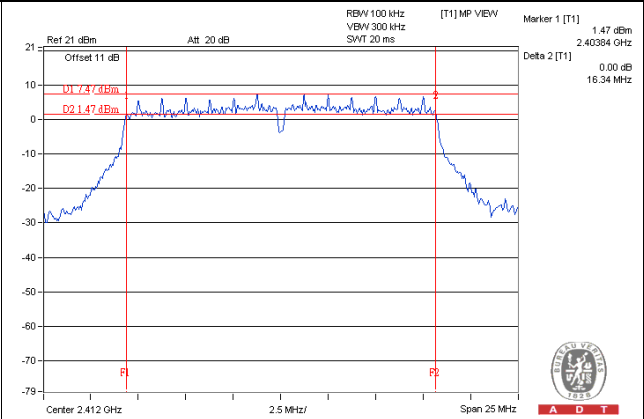

#### 802.11n (HT20) / CH1

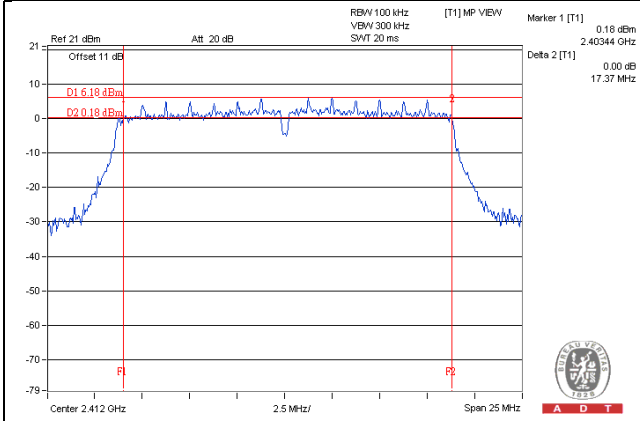

## 4.4 Conducted Output Power Measurement

### 4.4.1 Limits of Conducted Output Power Measurement

For systems using digital modulation in the 2400–2483.5 MHz bands: 1 Watt (30dBm)

Per KDB 662911 D01 Multiple Transmitter Output Method of conducted output power measurement on IEEE 802.11 devices,

Array Gain = 0 dB (i.e., no array gain) for  $NANT \leq 4$ ;

Array Gain = 0 dB (i.e., no array gain) for channel widths  $\geq 40$  MHz for any NANT;

Array Gain =  $5 \log(NANT/NSS)$  dB or 3 dB, whichever is less for 20-MHz channel widths with  $NANT \geq 5$ .

For power measurements on all other devices: Array Gain =  $10 \log(NANT/NSS)$  dB.

### 4.4.2 Test Setup

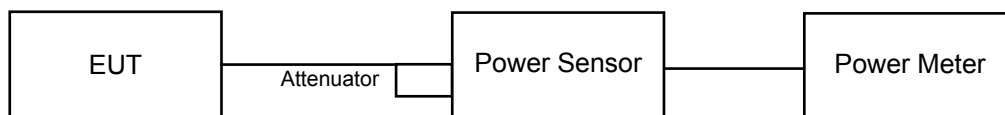

### 4.4.3 Test Instruments

Refer to section 4.1.2 to get information of above instrument.

### 4.4.4 Test Procedures

An average power sensor was used on the output port of the EUT. A power meter was used to read the response of the average power sensor. Record the power level.

### 4.4.5 Deviation from Test Standard

No deviation.

### 4.4.6 EUT Operating Conditions

Same as Item 4.3.6.

#### 4.4.7 Test Results

### FOR AVERAGE POWER

#### 3TX Mode

#### CDD Mode

#### 802.11b

Channel	Frequency (MHz)	Average Power (dBm)			Total Power (mW)	Total Power (dBm)	Limit (dBm)	Pass / Fail
		Chain 0	Chain 1	Chain 2				
1	2412	21.35	21.11	21.19	397.102	25.99	30	Pass
6	2437	21.24	21.17	21.23	396.702	25.98	30	Pass
11	2462	19.83	19.59	19.87	284.203	24.54	30	Pass

#### 802.11g

Channel	Frequency (MHz)	Average Power (dBm)			Total Power (mW)	Total Power (dBm)	Limit (dBm)	Pass / Fail
		Chain 0	Chain 1	Chain 2				
1	2412	17.64	17.65	17.32	170.237	22.31	30	Pass
6	2437	22.87	22.85	22.87	580.036	27.63	30	Pass
11	2462	17.45	17.38	17.14	162.053	22.10	30	Pass

#### 802.11n (HT20)

Channel	Frequency (MHz)	Average Power (dBm)			Total Power (mW)	Total Power (dBm)	Limit (dBm)	Pass / Fail
		Chain 0	Chain 1	Chain 2				
1	2412	16.28	16.08	15.95	122.368	20.88	30	Pass
6	2437	22.83	22.81	22.83	574.719	27.59	30	Pass
11	2462	15.34	15.01	14.79	96.024	19.82	30	Pass

#### Beamforming Mode

#### VHT20

Channel	Frequency (MHz)	Average Power (dBm)			Total Power (mW)	Total Power (dBm)	Limit (dBm)	Pass / Fail
		Chain 0	Chain 1	Chain 2				
1	2412	16.28	16.08	15.95	122.368	20.88	27.10	Pass
6	2437	22.11	22.15	22.31	496.83	26.96	27.10	Pass
11	2462	15.34	15.01	14.79	96.024	19.82	27.10	Pass

**Note:** Directional gain =  $10 \log[(10^{G1/20} + 10^{G2/20} + 10^{G3/20})^2 / 3] = 8.9\text{dBi} > 6\text{dBi}$ , so the power limit shall be reduced to  $30 - (8.9 - 6) = 27.10\text{dBm}$ .

**2TX Mode**

**CDD Mode**

**802.11b**

Channel	Frequency (MHz)	Average Power (dBm)		Total Power (mW)	Total Power (dBm)	Limit (dBm)	Pass / Fail
		Chain 0	Chain 1				
1	2412	21.35	21.11	265.58	24.24	30	Pass
6	2437	21.24	21.17	263.963	24.22	30	Pass
11	2462	21.21	21.15	262.447	24.19	30	Pass

**802.11g**

Channel	Frequency (MHz)	Average Power (dBm)		Total Power (mW)	Total Power (dBm)	Limit (dBm)	Pass / Fail
		Chain 0	Chain 1				
1	2412	17.98	17.92	124.75	20.96	30	Pass
6	2437	22.87	22.85	386.394	25.87	30	Pass
11	2462	17.59	17.45	113.002	20.53	30	Pass

**802.11n (HT20)**

Channel	Frequency (MHz)	Average Power (dBm)		Total Power (mW)	Total Power (dBm)	Limit (dBm)	Pass / Fail
		Chain 0	Chain 1				
1	2412	16.42	16.39	87.404	19.42	30	Pass
6	2437	22.83	22.81	382.852	25.83	30	Pass
11	2462	15.45	15.21	68.264	18.34	30	Pass

**Beamforming Mode**

**VHT20**

Channel	Frequency (MHz)	Average Power (dBm)		Total Power (mW)	Total Power (dBm)	Limit (dBm)	Pass / Fail
		Chain 0	Chain 1				
1	2412	16.42	16.39	87.404	19.42	28.27	Pass
6	2437	22.83	22.81	382.852	25.83	28.27	Pass
11	2462	15.45	15.21	68.264	18.34	28.27	Pass

**Note:** Directional gain =  $10 \log[(10^{G1/20} + 10^{G2/20})^2 / 2] = 7.73\text{dBi} > 6\text{dBi}$  , so the power limit shall be reduced to  $30 - (7.73 - 6) = 28.27\text{dBm}$ .

**CDD Mode****1TX Mode****802.11b**

Channel	Frequency (MHz)	Average Power (mW)	Average Power (dBm)	Limit (dBm)	Pass / Fail
1	2412	91.411	19.61	30	Pass
6	2437	92.47	19.66	30	Pass
11	2462	83.368	19.21	30	Pass

**802.11g**

Channel	Frequency (MHz)	Average Power (mW)	Average Power (dBm)	Limit (dBm)	Pass / Fail
1	2412	70.958	18.51	30	Pass
6	2437	193.642	22.87	30	Pass
11	2462	60.395	17.81	30	Pass

**802.11n (HT20)**

Channel	Frequency (MHz)	Average Power (mW)	Average Power (dBm)	Limit (dBm)	Pass / Fail
1	2412	50.234	17.01	30	Pass
6	2437	191.867	22.83	30	Pass
11	2462	39.902	16.01	30	Pass

## 4.5 Power Spectral Density Measurement

### 4.5.1 Limits of Power Spectral Density Measurement

The Maximum of Power Spectral Density Measurement is 8dBm.

### 4.5.2 Test Setup

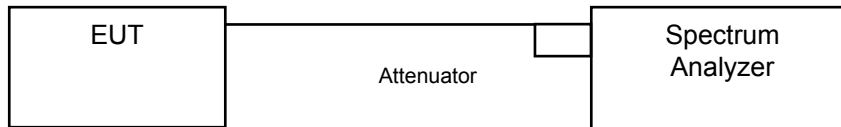

### 4.5.3 Test Instruments

Refer to section 4.1.2 to get information of above instrument.

### 4.5.4 Test Procedure

- a) Set instrument center frequency to DTS channel center frequency.
- b) Set span to at least 1.5 times the OBW.
- c) Set RBW to:  $3 \text{ kHz} \leq \text{RBW} \leq 100 \text{ kHz}$ .
- d) Set VBW  $\geq 3 \times \text{RBW}$ .
- e) Detector = power averaging (RMS) or sample detector (when RMS not available).
- f) Ensure that the number of measurement points in the sweep  $\geq 2 \times \text{span}/\text{RBW}$ .
- g) Sweep time = auto couple.
- h) Employ trace averaging (RMS) mode over a minimum of 100 traces.
- i) Use the peak marker function to determine the maximum amplitude level.

### 4.5.5 Deviation from Test Standard

No deviation.

### 4.5.6 EUT Operating Condition

Same as Item 4.3.6

#### 4.5.7 Test Results

##### 3TX Mode

##### CDD Mode

##### 802.11b

TX chain	Channel	Freq. (MHz)	PSD (dBm/10kHz)	10 log (N=3) dB	Total PSD (dBm/10kHz)	Limit (dBm/3kHz)	Pass /Fail
0	1	2412	-7.04	4.77	-2.27	5.10	Pass
	6	2437	-6.95	4.77	-2.18	5.10	Pass
	11	2462	-8.54	4.77	-3.77	5.10	Pass
1	1	2412	-6.93	4.77	-2.16	5.10	Pass
	6	2437	-7.03	4.77	-2.26	5.10	Pass
	11	2462	-8.42	4.77	-3.65	5.10	Pass
2	1	2412	-7.06	4.77	-2.29	5.10	Pass
	6	2437	-7.08	4.77	-2.31	5.10	Pass
	11	2462	-7.98	4.77	-3.21	5.10	Pass

**NOTE:** Directional gain =  $10 \log[(10^{G1/20} + 10^{G2/20} + 10^{G3/20})^2 / 3]$  = 8.9dBi > 6dBi , so the power density limit shall be reduced to 8-(8.9-6) = 5.10dBm.

##### 802.11g

TX chain	Channel	Freq. (MHz)	PSD (dBm/10kHz)	10 log (N=3) dB	Total PSD (dBm/10kHz)	Limit (dBm/3kHz)	Pass /Fail
0	1	2412	-12.12	4.77	-7.35	5.10	Pass
	6	2437	-6.94	4.77	-2.17	5.10	Pass
	11	2462	-12.09	4.77	-7.32	5.10	Pass
1	1	2412	-10.60	4.77	-5.83	5.10	Pass
	6	2437	-6.46	4.77	-1.69	5.10	Pass
	11	2462	-12.53	4.77	-7.76	5.10	Pass
2	1	2412	-11.41	4.77	-6.64	5.10	Pass
	6	2437	-6.31	4.77	-1.54	5.10	Pass
	11	2462	-12.39	4.77	-7.62	5.10	Pass

**NOTE:** Directional gain =  $10 \log[(10^{G1/20} + 10^{G2/20} + 10^{G3/20})^2 / 3]$  = 8.9dBi > 6dBi , so the power density limit shall be reduced to 8-(8.9-6) = 5.10dBm.



**802.11n (HT20)**

TX chain	Channel	Freq. (MHz)	PSD (dBm/10kHz)	10 log (N=3) dB	Total PSD (dBm/10kHz)	Limit (dBm/3kHz)	Pass /Fail
0	1	2412	-14.05	4.77	-9.28	5.10	Pass
	6	2437	-7.65	4.77	-2.88	5.10	Pass
	11	2462	-15.75	4.77	-10.98	5.10	Pass
1	1	2412	-13.08	4.77	-8.31	5.10	Pass
	6	2437	-8.04	4.77	-3.27	5.10	Pass
	11	2462	-15.82	4.77	-11.05	5.10	Pass
2	1	2412	-14.95	4.77	-10.18	5.10	Pass
	6	2437	-8.95	4.77	-4.18	5.10	Pass
	11	2462	-15.18	4.77	-10.41	5.10	Pass

**NOTE:** Directional gain =  $10 \log[(10^{G1/20} + 10^{G2/20} + 10^{G3/20})^2 / 3]$  = 8.9dBi > 6dBi , so the power density limit shall be reduced to 8-(8.9-6) = 5.10dBm.

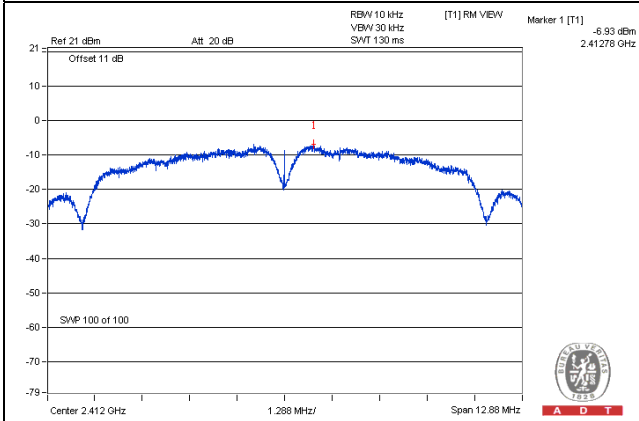
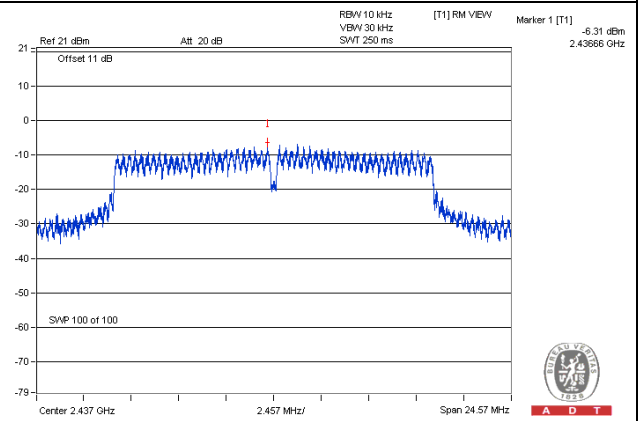
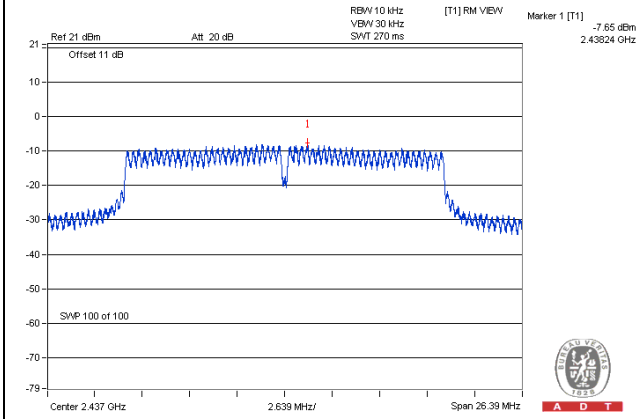
**Spectrum Plot of Worst Value****802.11b / Chain 1 : CH1****802.11g / Chain 2 : CH6****802.11n (HT20) / Chain 0 : CH6**

**2TX Mode**

**802.11b**

TX chain	Channel	Freq. (MHz)	PSD (dBm/10kHz)	10 log (N=2) dB	Total PSD (dBm/10kHz)	Limit (dBm/3kHz)	Pass /Fail
0	1	2412	-7.04	3.01	-4.03	6.27	Pass
	6	2437	-6.95	3.01	-3.94	6.27	Pass
	11	2462	-6.96	3.01	-3.95	6.27	Pass
1	1	2412	-6.93	3.01	-3.92	6.27	Pass
	6	2437	-7.03	3.01	-4.02	6.27	Pass
	11	2462	-6.67	3.01	-3.66	6.27	Pass

**NOTE:** Directional gain =  $10 \log[(10^{G1/20} + 10^{G2/20})^2 / 2]$  = 7.73dBi > 6dBi , so the power density limit shall be reduced to  $8-(7.73-6) = 6.27$ dBm.

**802.11g**

TX chain	Channel	Freq. (MHz)	PSD (dBm/10kHz)	10 log (N=2) dB	Total PSD (dBm/10kHz)	Limit (dBm/3kHz)	Pass /Fail
0	1	2412	-11.21	3.01	-8.20	6.27	Pass
	6	2437	-6.94	3.01	-3.93	6.27	Pass
	11	2462	-11.48	3.01	-8.47	6.27	Pass
1	1	2412	-10.15	3.01	-7.14	6.27	Pass
	6	2437	-6.46	3.01	-3.45	6.27	Pass
	11	2462	-11.46	3.01	-8.45	6.27	Pass

**NOTE:** Directional gain =  $10 \log[(10^{G1/20} + 10^{G2/20})^2 / 2]$  = 7.73dBi > 6dBi , so the power density limit shall be reduced to  $8-(7.73-6) = 6.27$ dBm.

**802.11n (HT20)**

TX chain	Channel	Freq. (MHz)	PSD (dBm/10kHz)	10 log (N=2) dB	Total PSD (dBm/10kHz)	Limit (dBm/3kHz)	Pass /Fail
0	1	2412	-13.47	3.01	-10.46	6.27	Pass
	6	2437	-7.65	3.01	-4.64	6.27	Pass
	11	2462	-15.22	3.01	-12.21	6.27	Pass
1	1	2412	-13.62	3.01	-10.61	6.27	Pass
	6	2437	-8.04	3.01	-5.03	6.27	Pass
	11	2462	-15.21	3.01	-12.20	6.27	Pass

**NOTE:** Directional gain =  $10 \log[(10^{G1/20} + 10^{G2/20})^2 / 2]$  = 7.73dBi > 6dBi , so the power density limit shall be reduced to  $8-(7.73-6) = 6.27$ dBm.

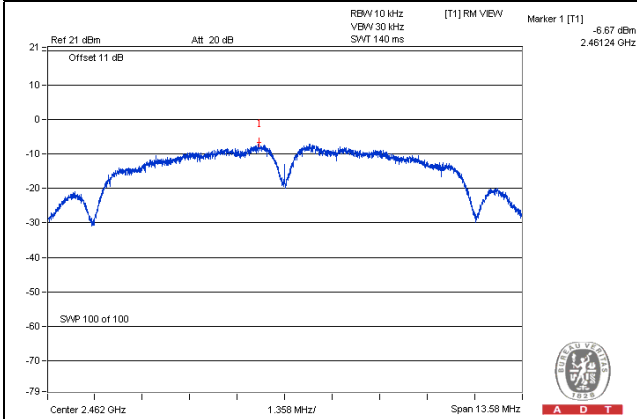
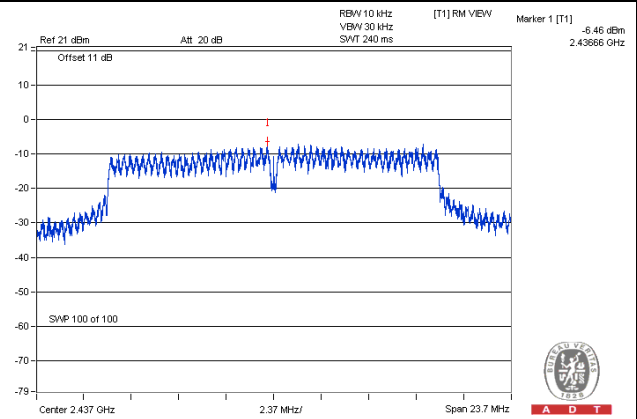
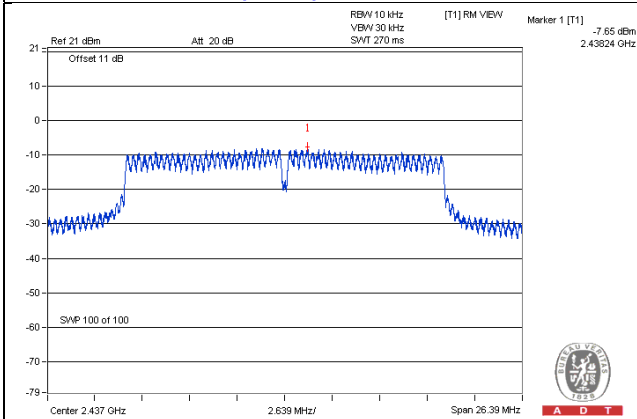
**Spectrum Plot of Worst Value****802.11b / Chain 1 : CH11****802.11g / Chain 1 : CH6****802.11n (HT20) / Chain 0 : CH6**

**1TX Mode****802.11b**

Channel	Freq. (MHz)	PSD (dBm/10kHz)	Limit (dBm/3kHz)	Pass /Fail
1	2412	-8.74	8.00	Pass
6	2437	-8.74	8.00	Pass
11	2462	-8.71	8.00	Pass

**802.11g**

Channel	Freq. (MHz)	PSD (dBm/10kHz)	Limit (dBm/3kHz)	Pass /Fail
1	2412	-10.57	8.00	Pass
6	2437	-6.94	8.00	Pass
11	2462	-11.02	8.00	Pass

**802.11n (HT20)**

Channel	Freq. (MHz)	PSD (dBm/10kHz)	Limit (dBm/3kHz)	Pass /Fail
1	2412	-13.20	8.00	Pass
6	2437	-7.65	8.00	Pass
11	2462	-14.54	8.00	Pass

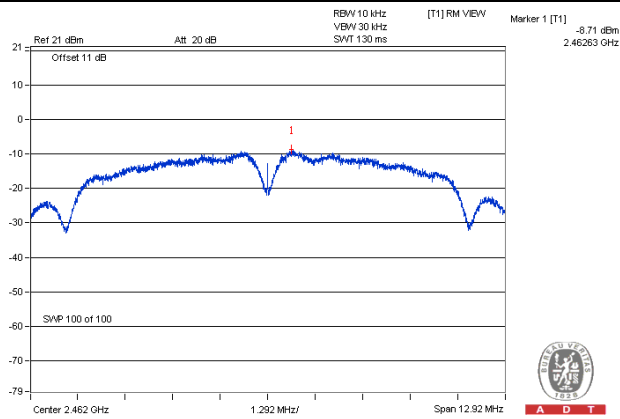
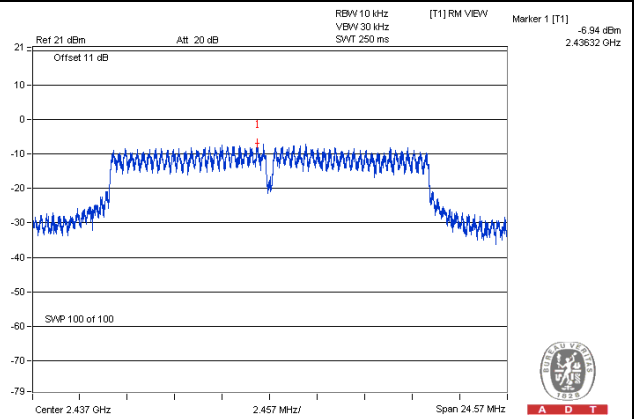
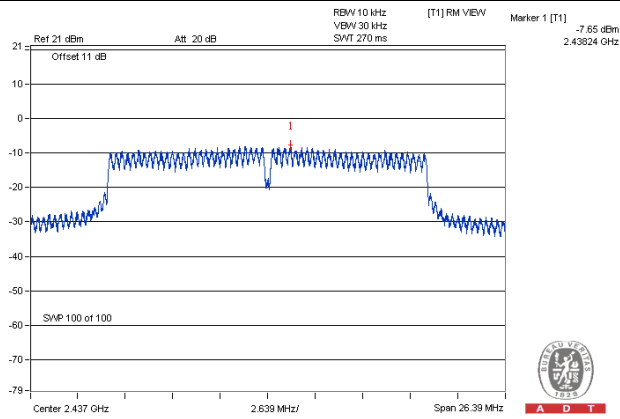
**Spectrum Plot of Worst Value****802.11b / CH11****802.11g / CH6****802.11n (HT20) / CH6**

## 4.6 Conducted Out of Band Emission Measurement

### 4.6.1 Limits of Conducted Out of Band Emission Measurement

Below 30dB of the highest emission level of operating band (in 100kHz Resolution Bandwidth).

### 4.6.2 Test Setup

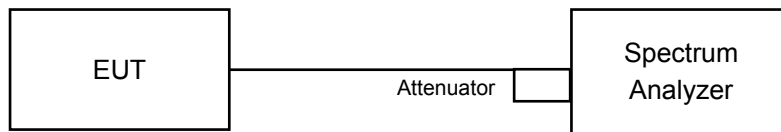

### 4.6.3 Test Instruments

Refer to section 4.1.2 to get information of above instrument.

### 4.6.4 Test Procedure

#### MEASUREMENT PROCEDURE REF

1. Set the RBW = 100 kHz.
2. Set the VBW  $\geq$  300 kHz.
3. Detector = peak.
4. Sweep time = auto couple.
5. Trace mode = max hold.
6. Allow trace to fully stabilize.
7. Use the peak marker function to determine the maximum power level in any 100 kHz band segment within the fundamental EBW.

#### MEASUREMENT PROCEDURE OOB

1. Set RBW = 100 kHz.
2. Set VBW  $\geq$  300 kHz.
3. Detector = peak.
4. Sweep = auto couple.
5. Trace Mode = max hold.
6. Allow trace to fully stabilize.
7. Use the peak marker function to determine the maximum amplitude level.

### 4.6.5 Deviation from Test Standard

No deviation.

### 4.6.6 EUT Operating Condition

Same as Item 4.3.6

#### 4.6.7 Test Results

The spectrum plots are attached on the following pages. D1 line indicates the highest level, and D2 line indicates the 30dB offset below D1. It shows compliance with the requirement.



**3TX Mode**  
**802.11b**

**Chain 0**

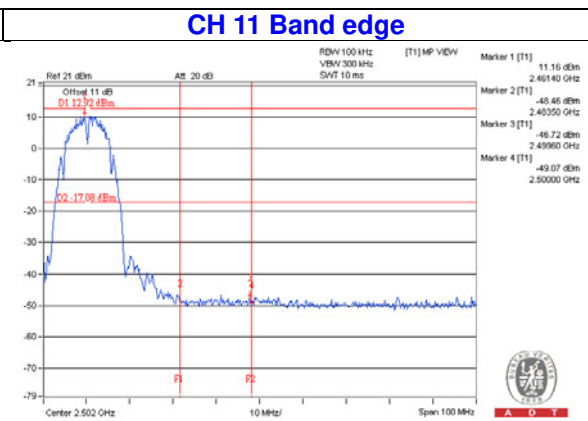
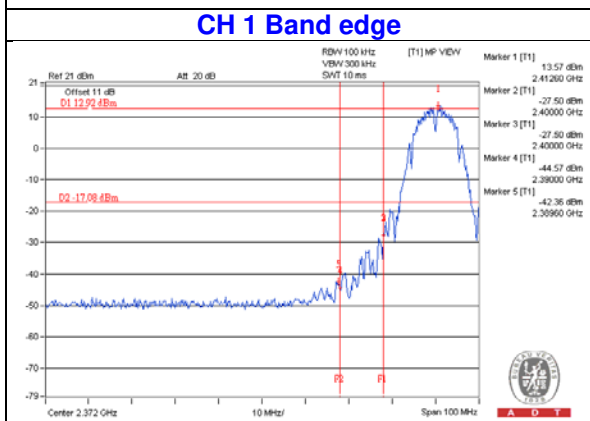
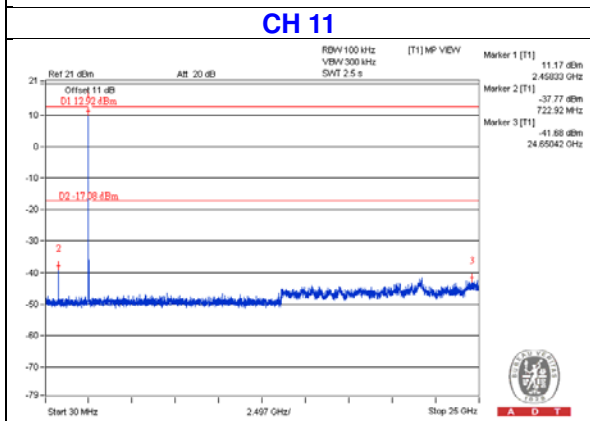
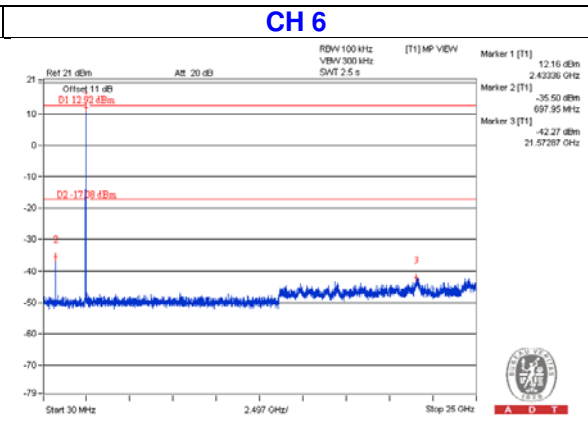
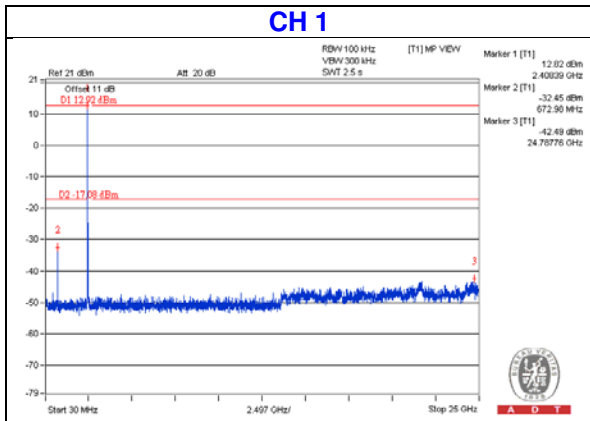
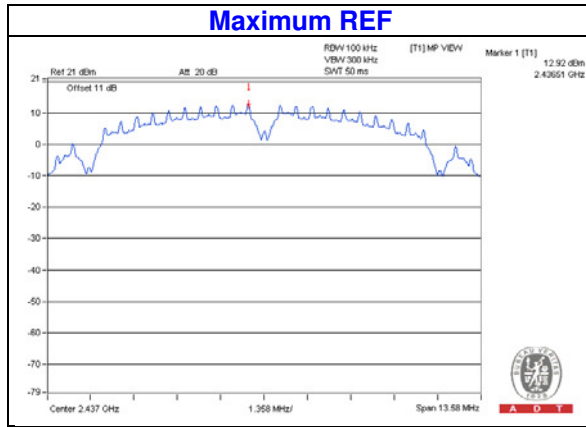

Chain 1

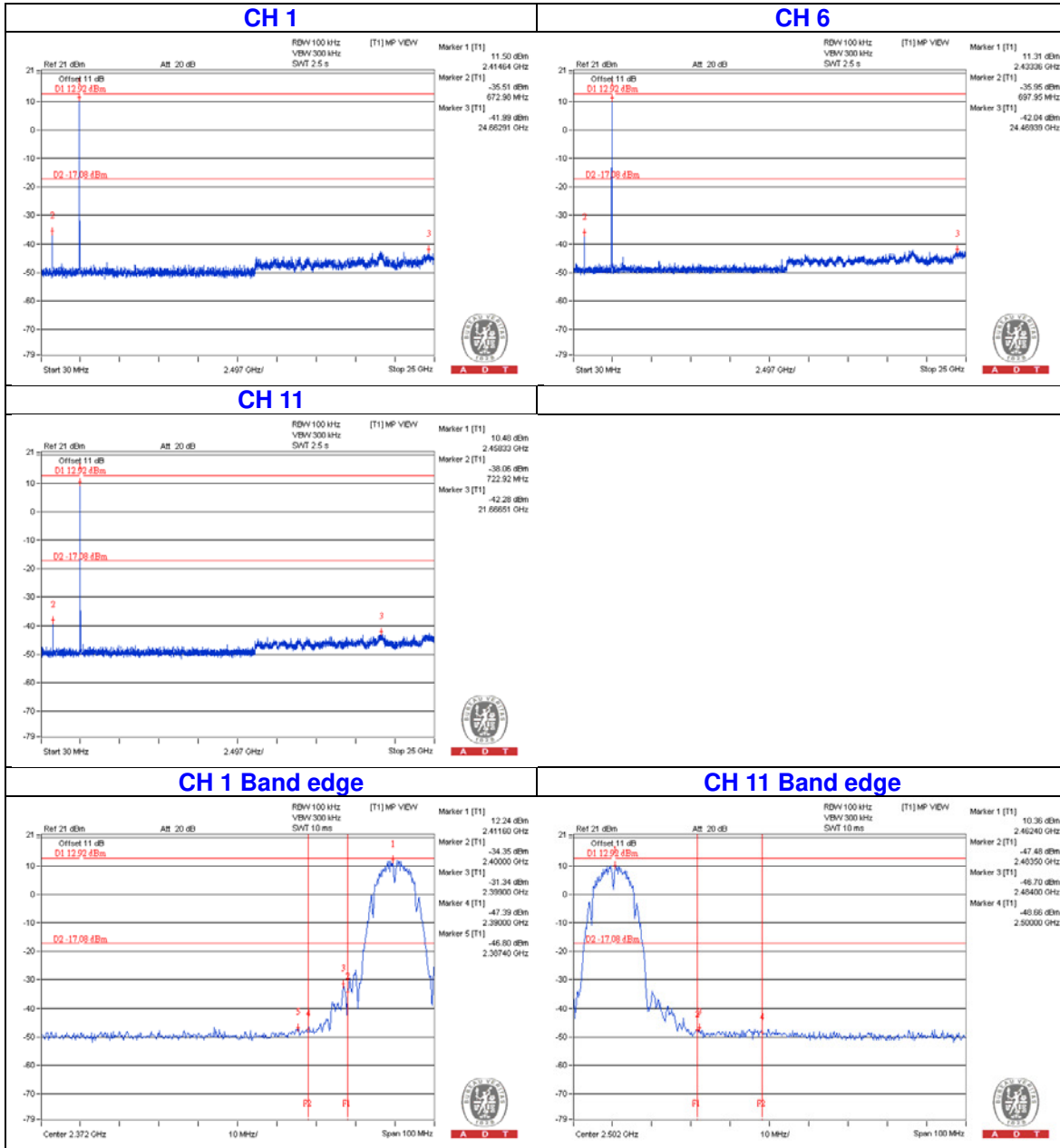

Chain 2

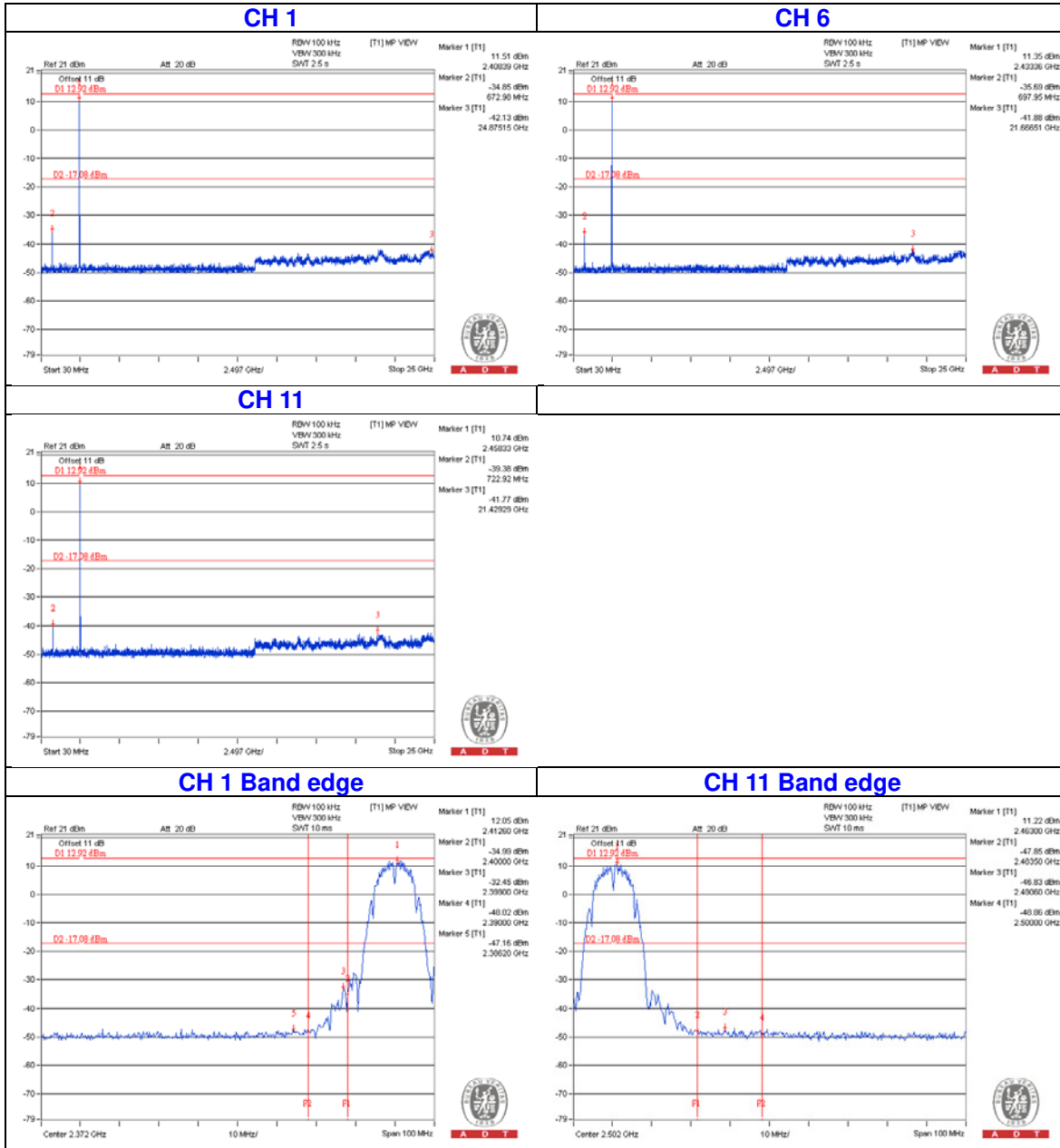

802.11g

Chain 0

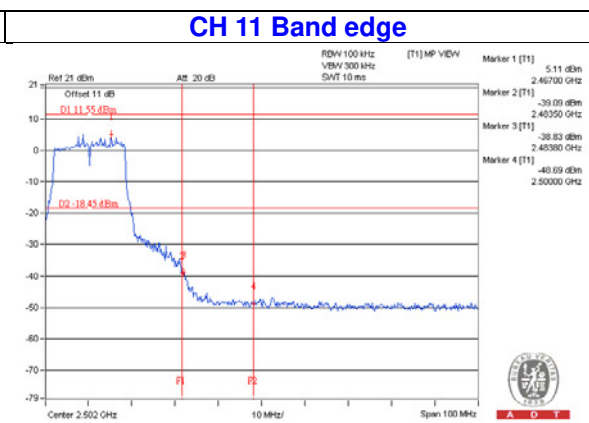
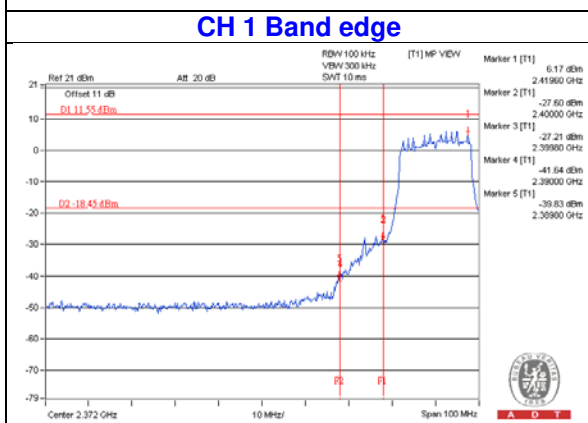
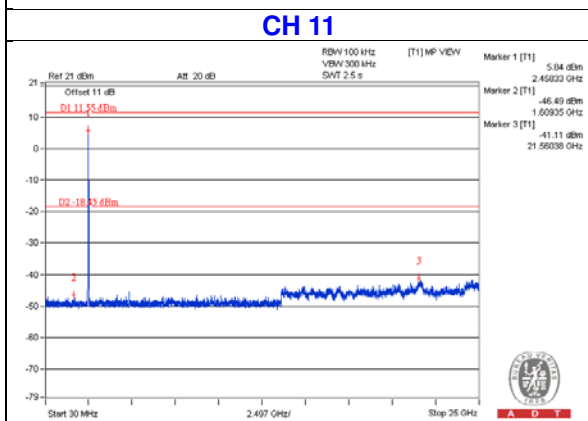
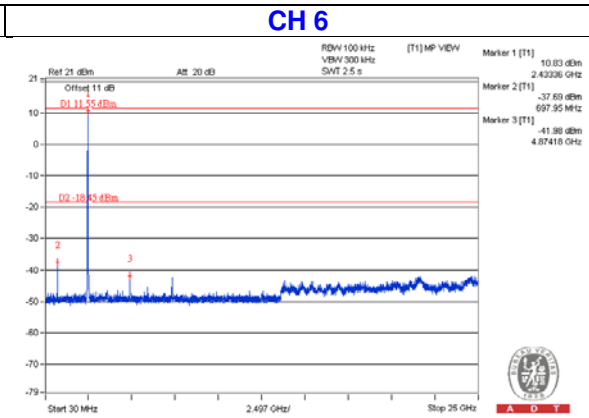
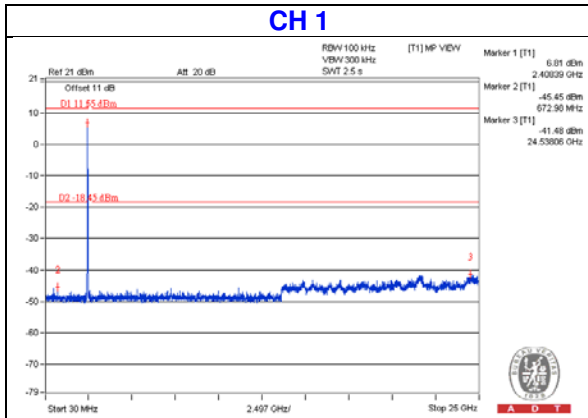
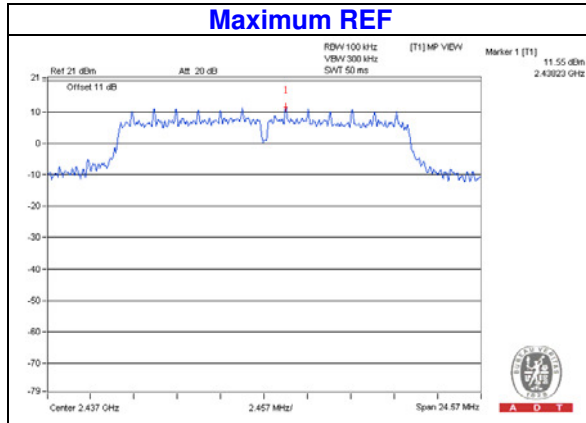

Chain 1

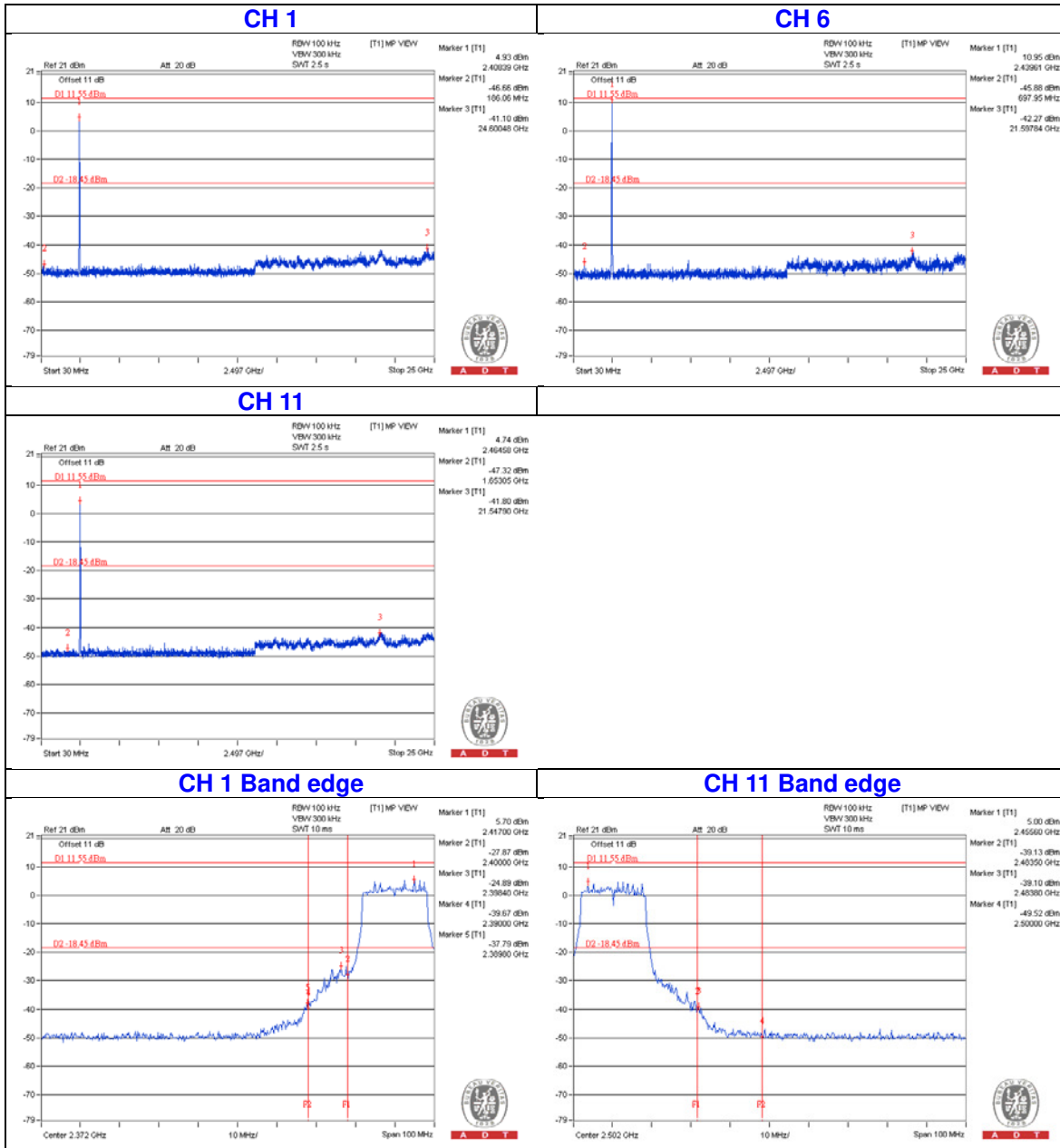

Chain 2

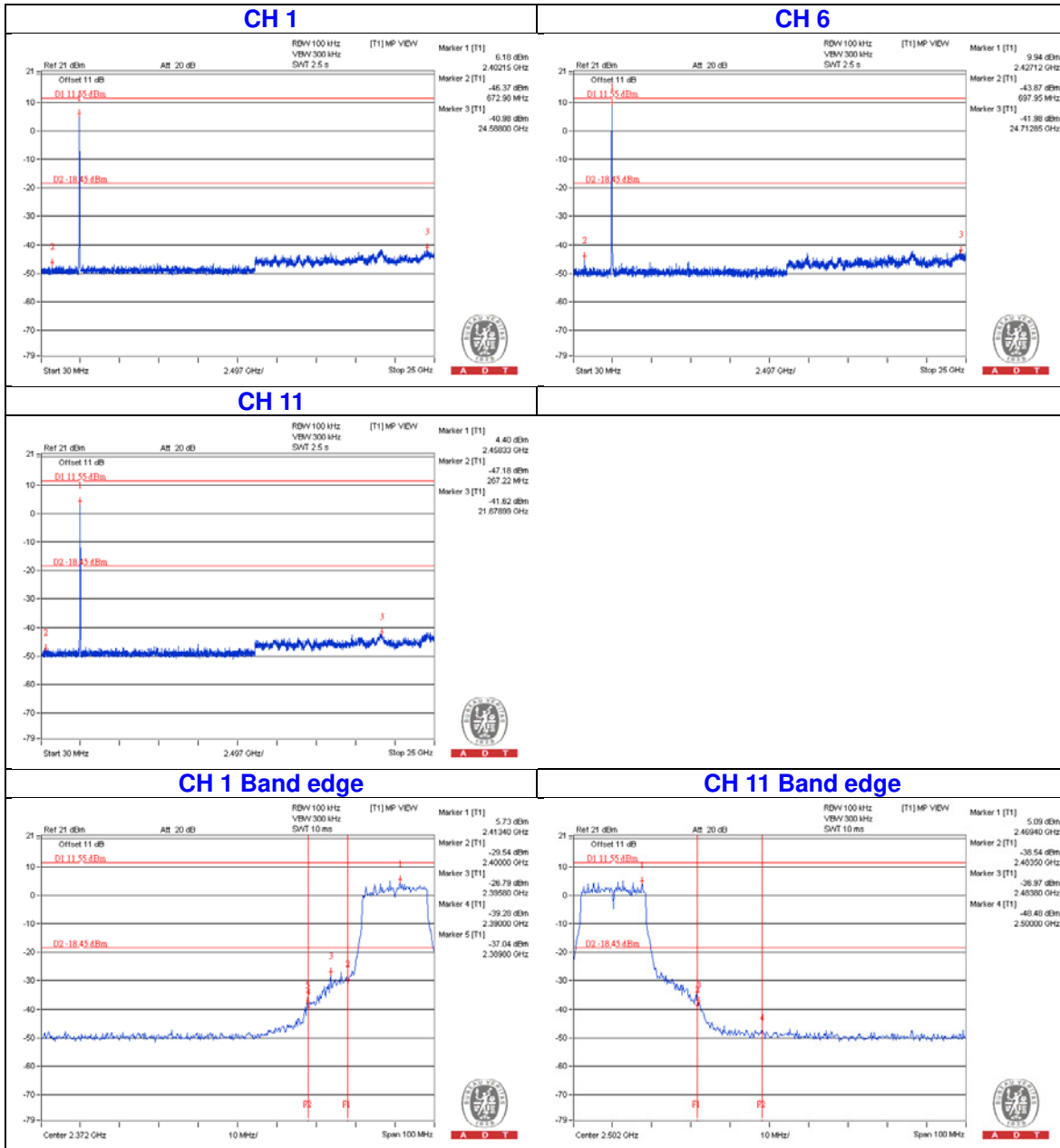

802.11n (HT20)

Chain 0

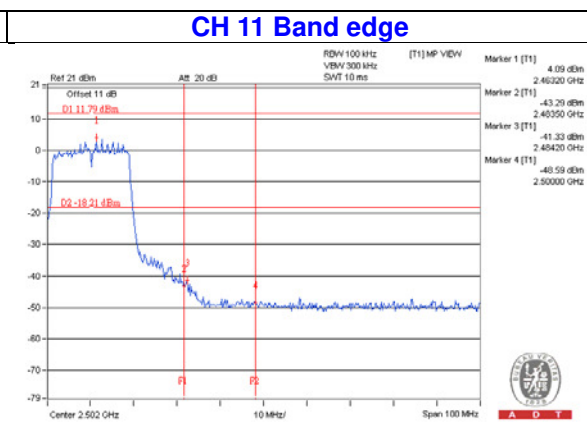
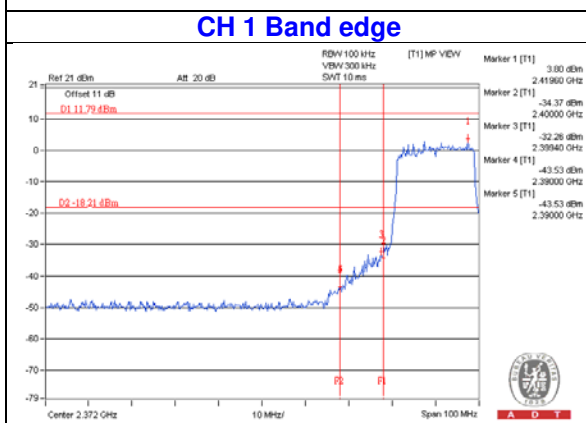
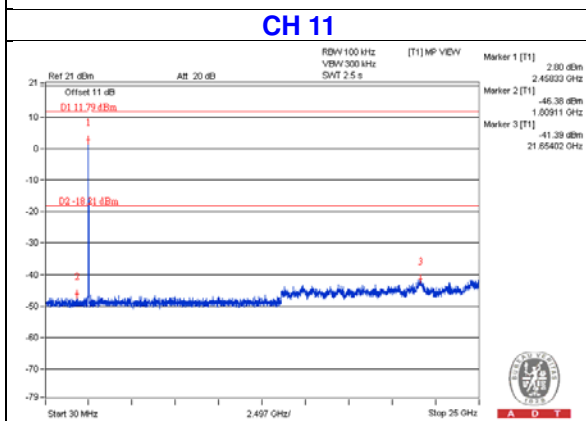
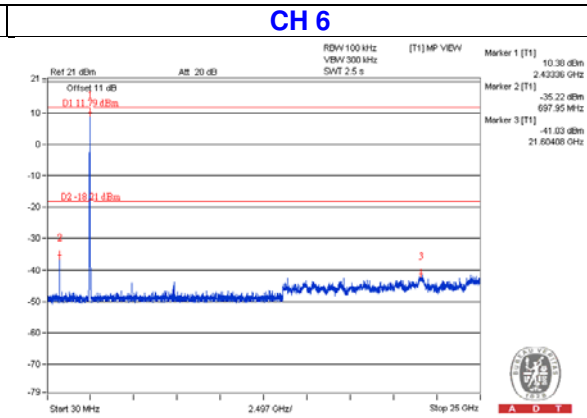
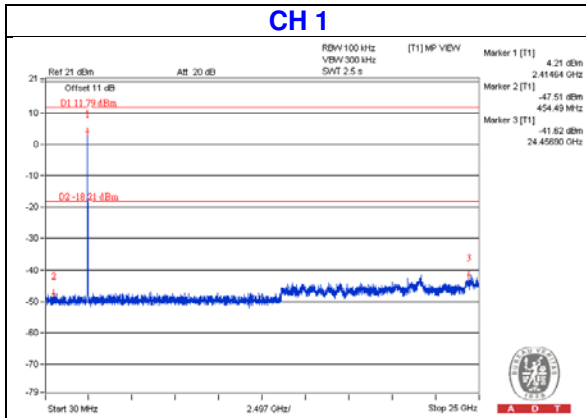
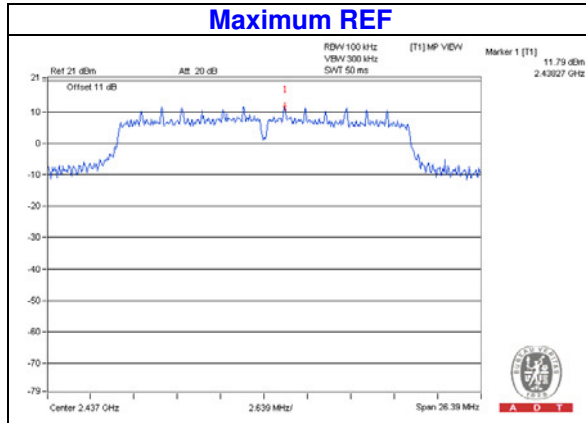

Chain 1

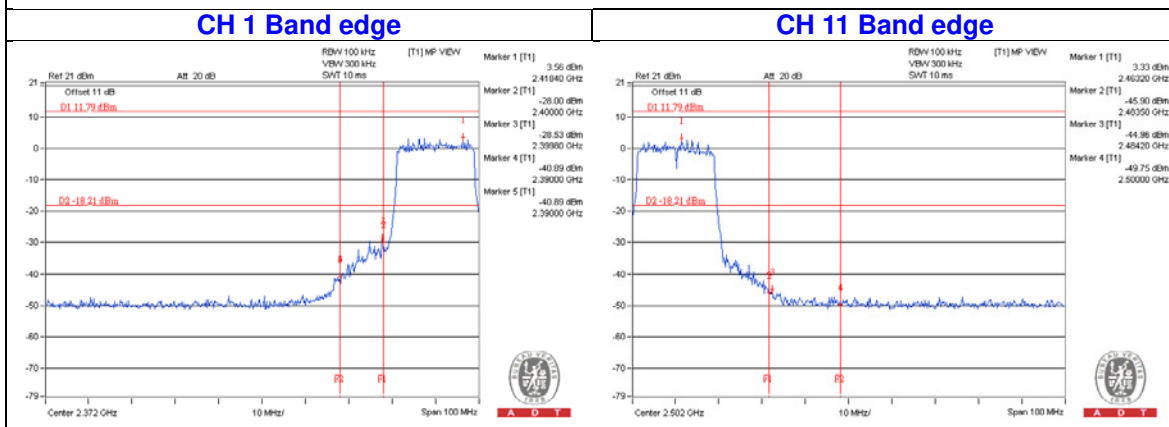
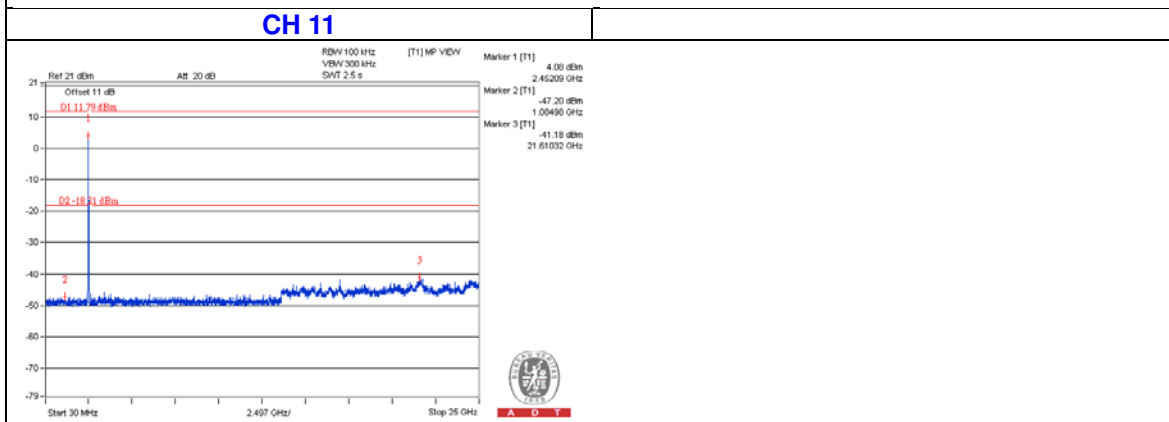
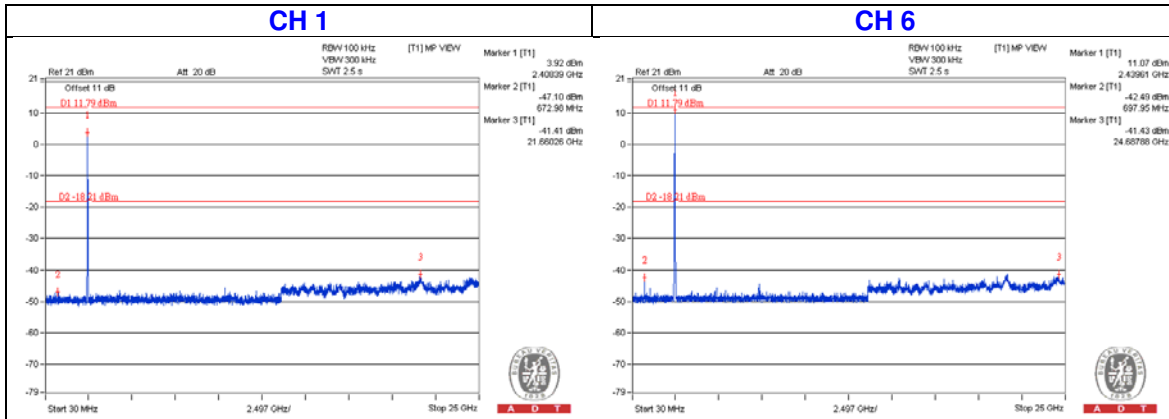



## Chain 2

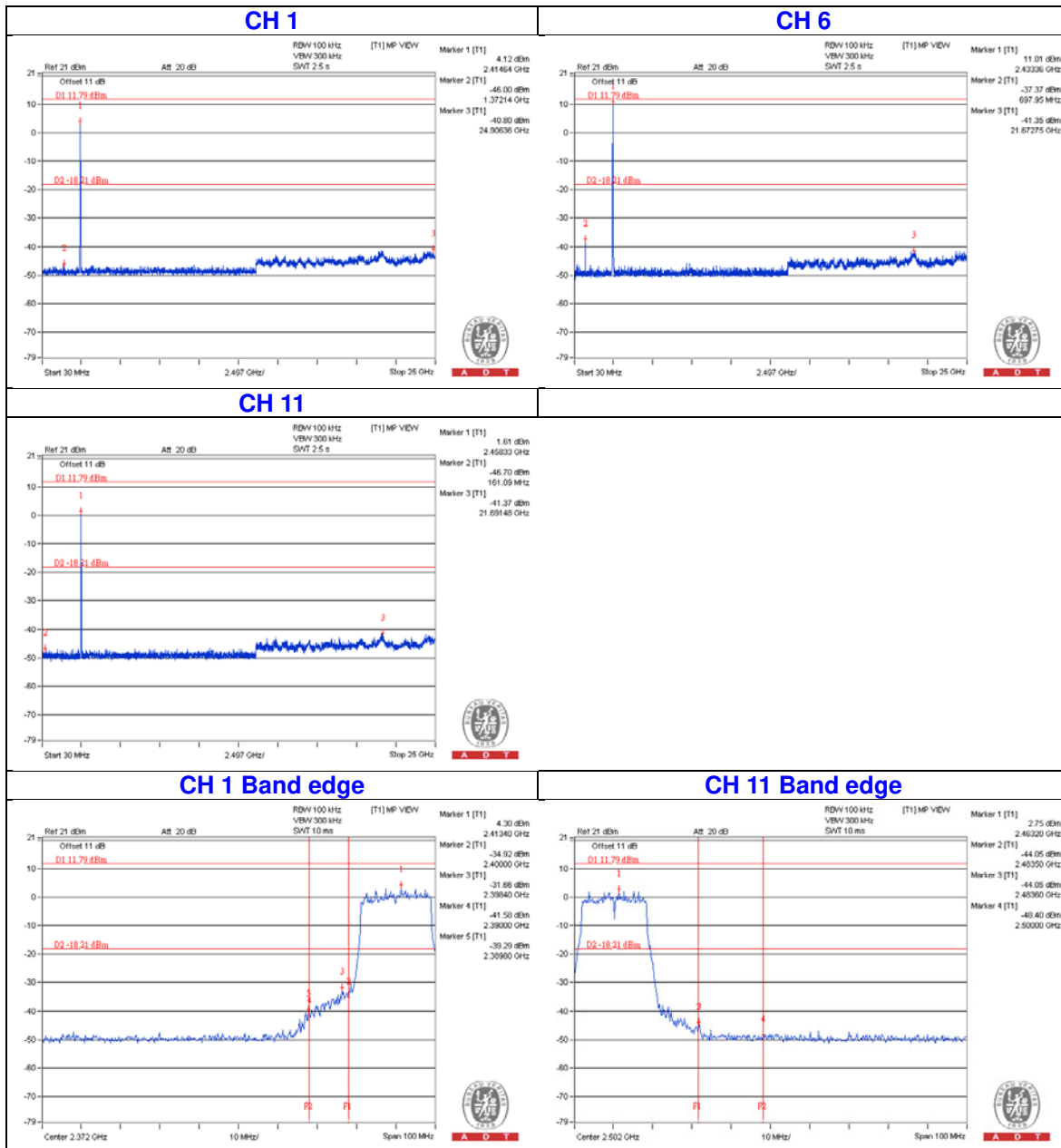

2TX Mode  
802.11b

Chain 0

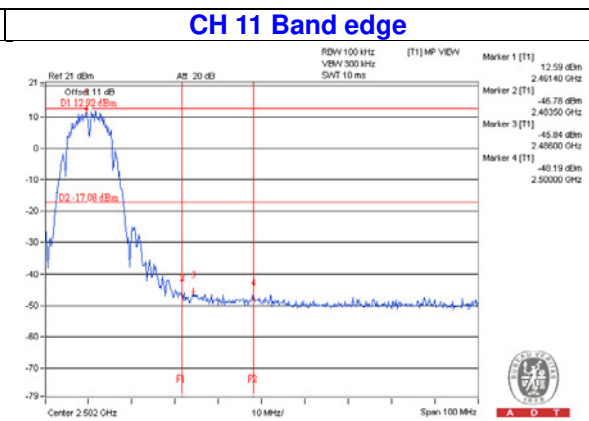
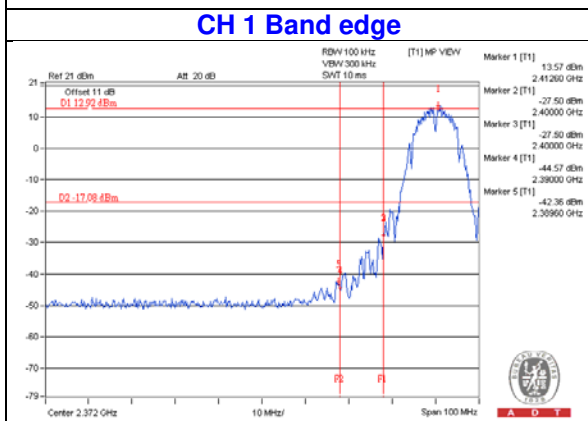
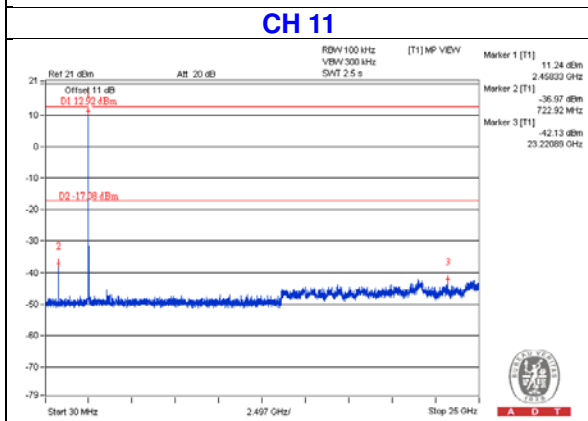
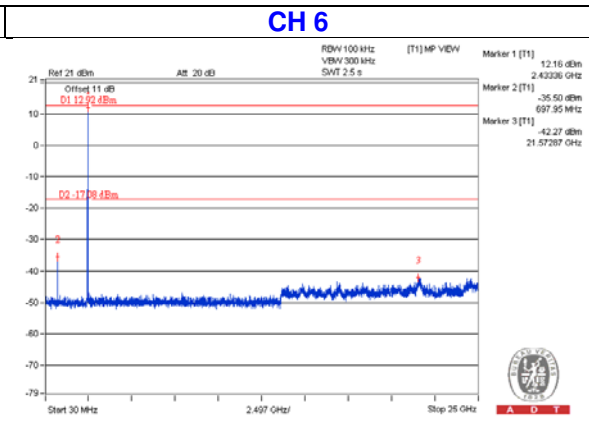
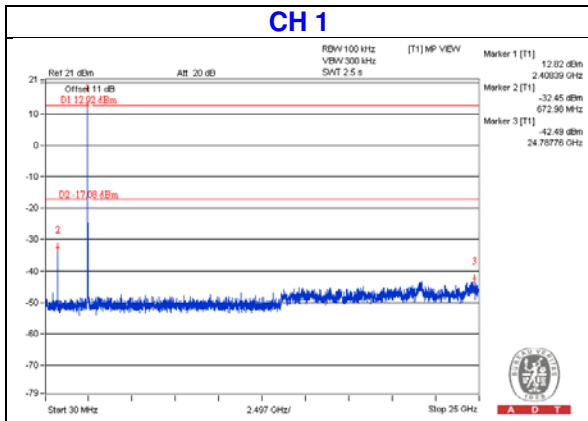
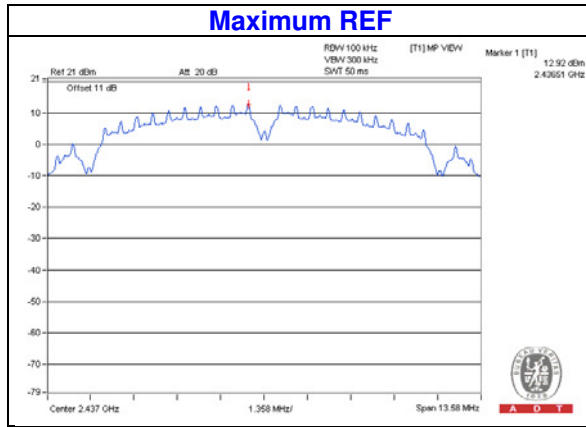

Chain 1

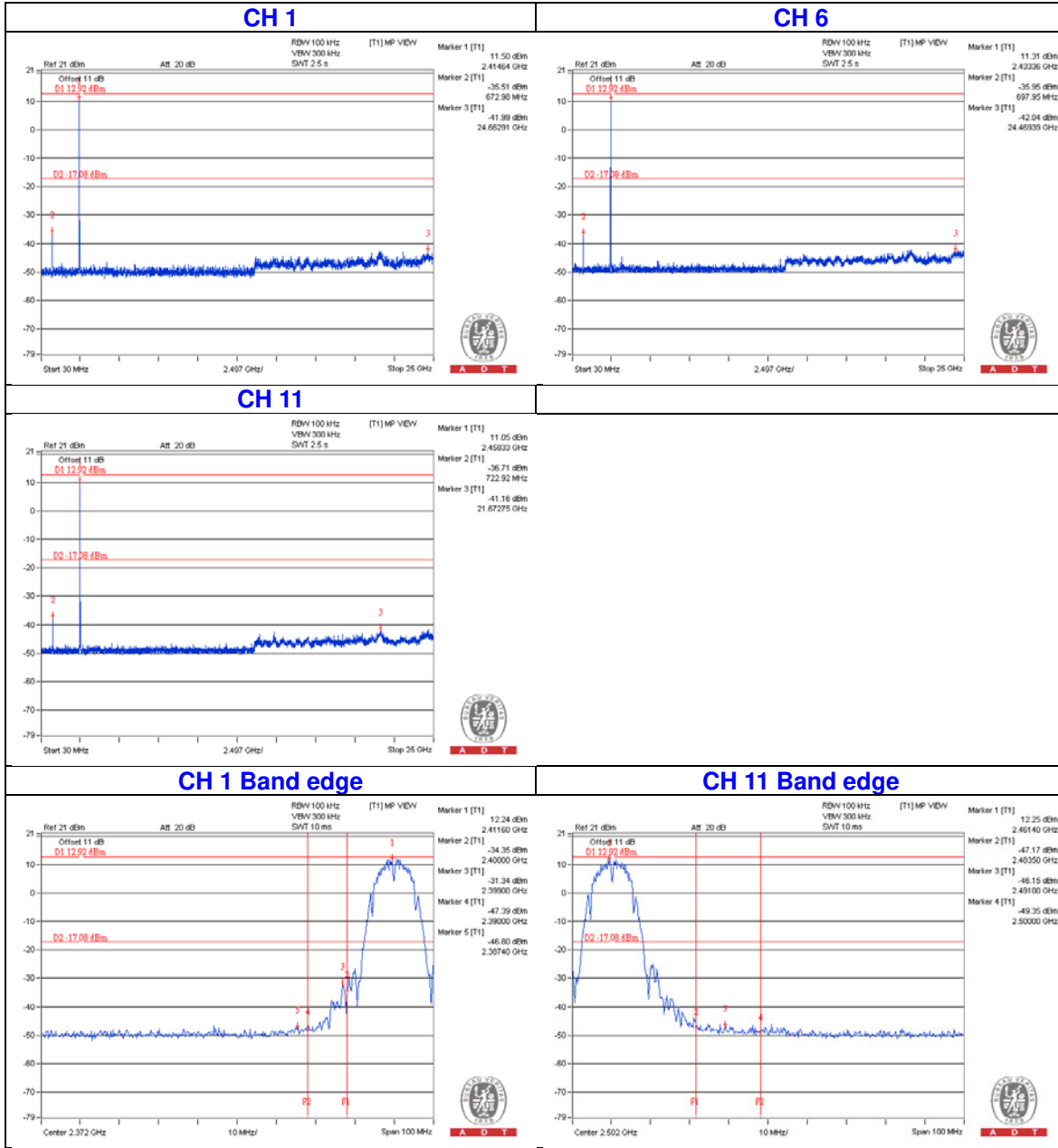

802.11g

Chain 0

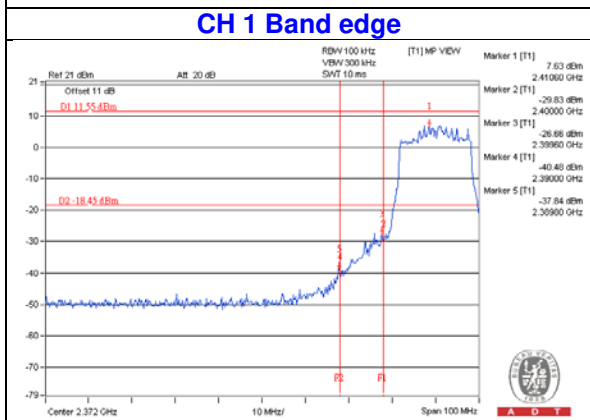
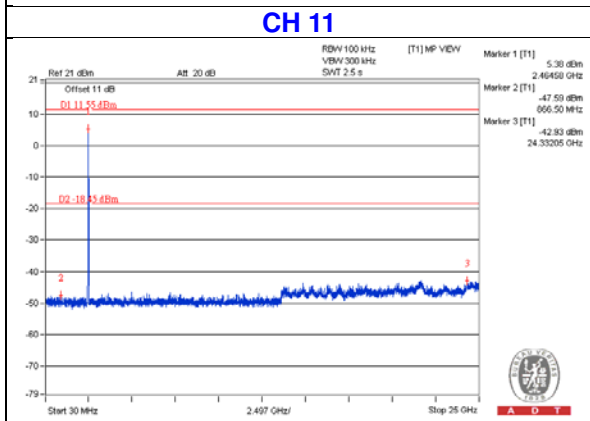
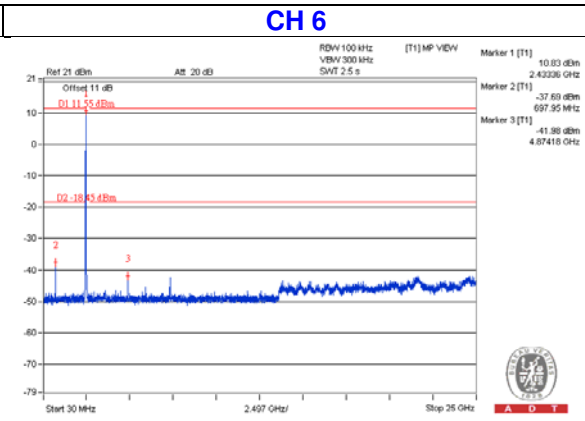
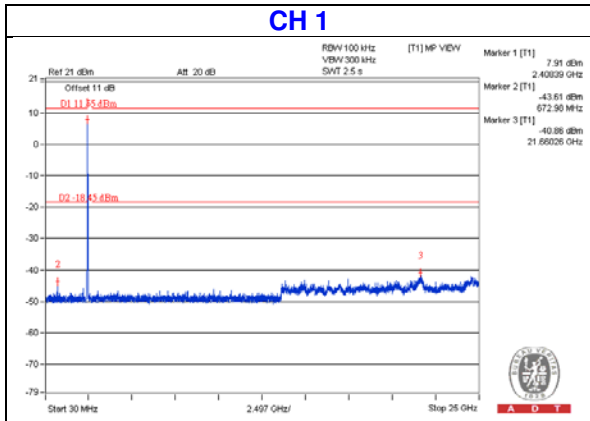
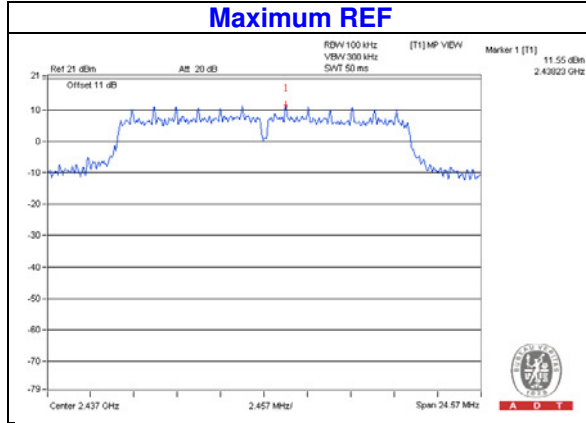

Chain 1

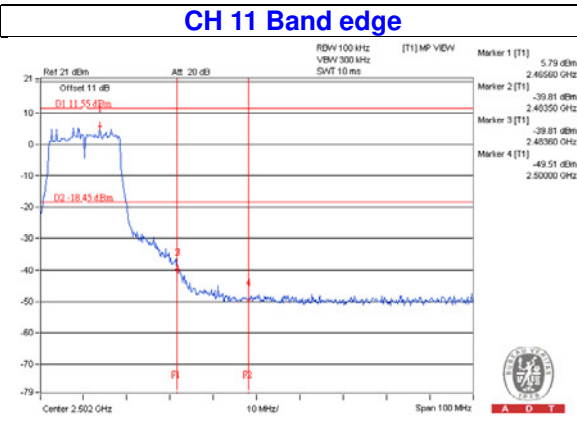
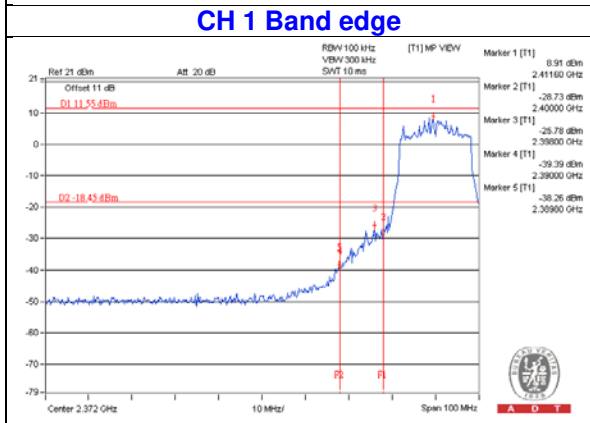
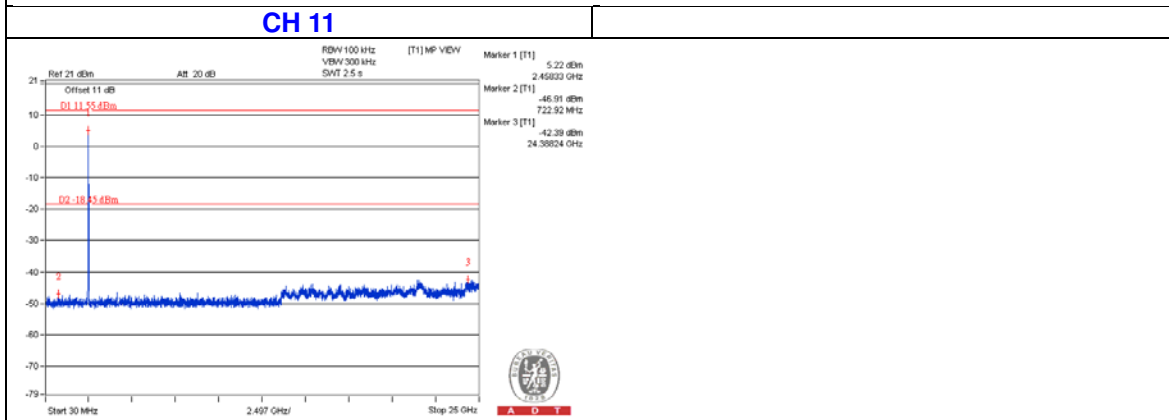
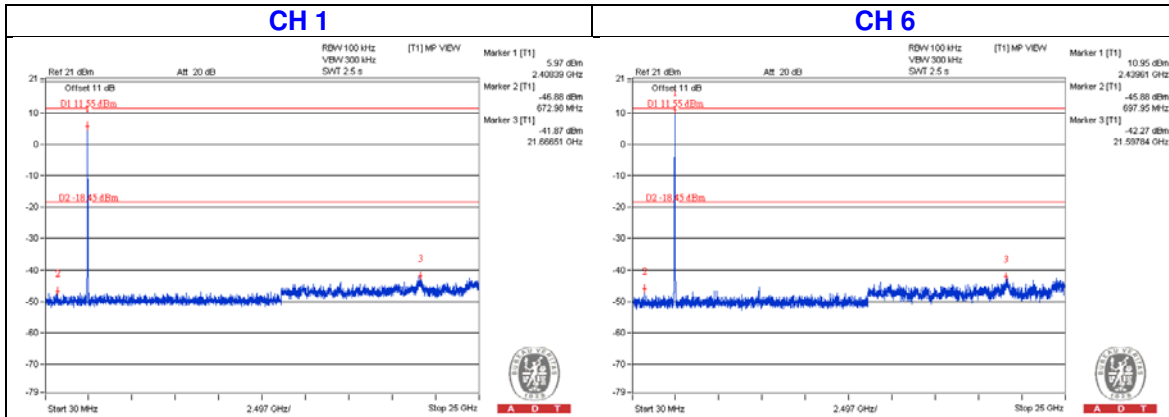

802.11n (HT20)

Chain 0

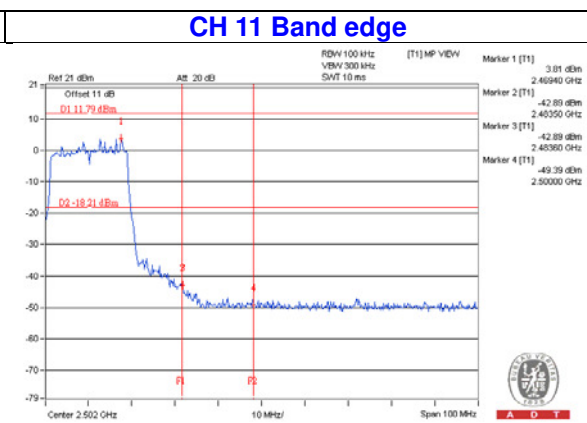
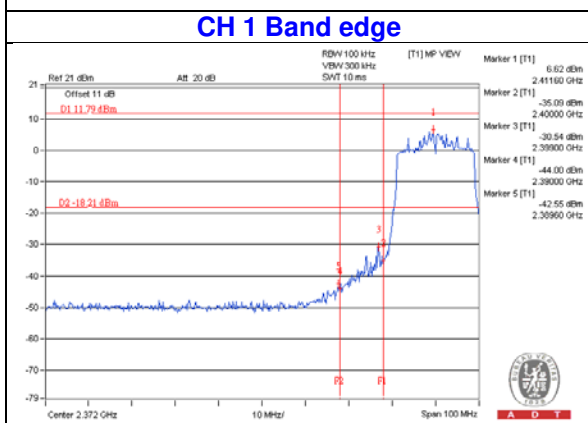
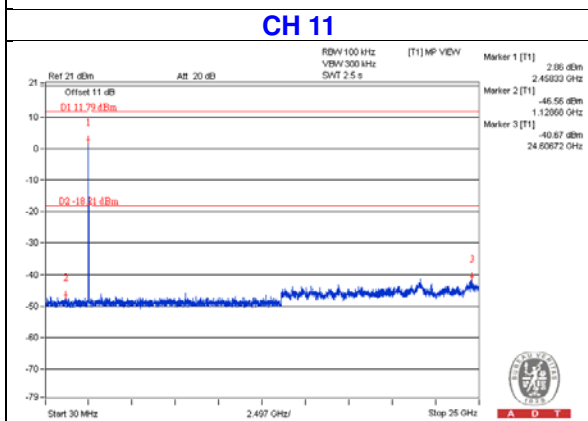
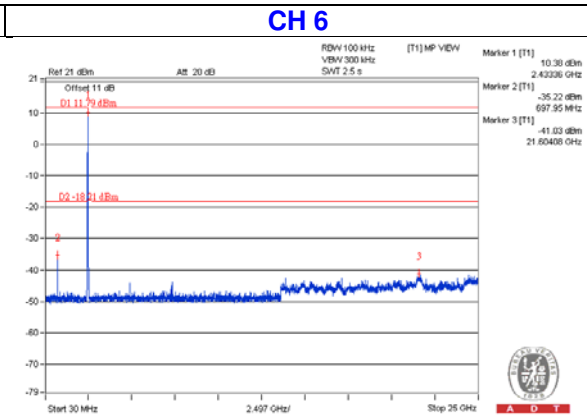
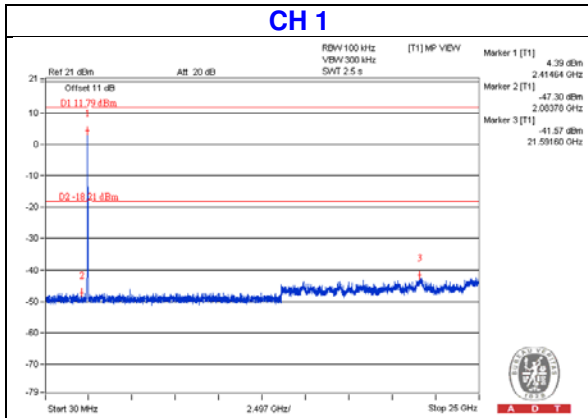
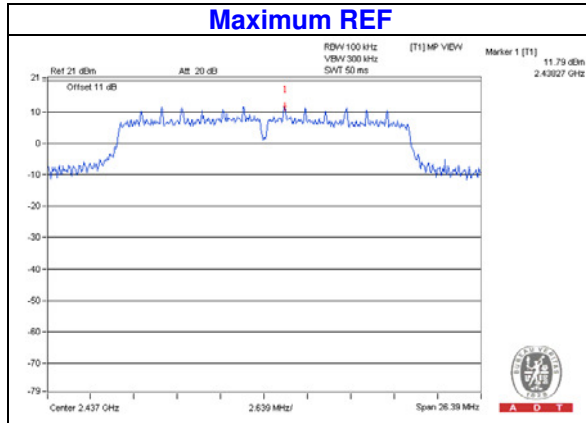

Chain 1

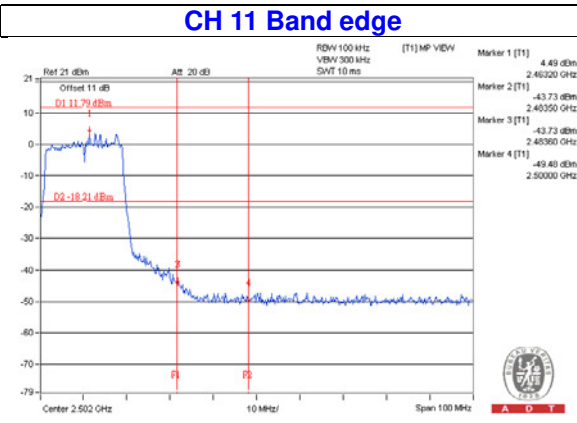
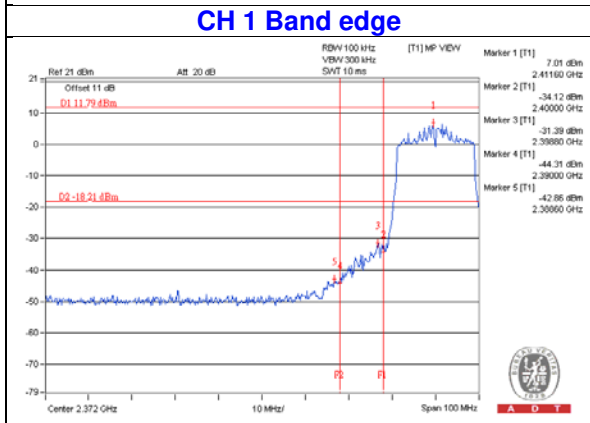
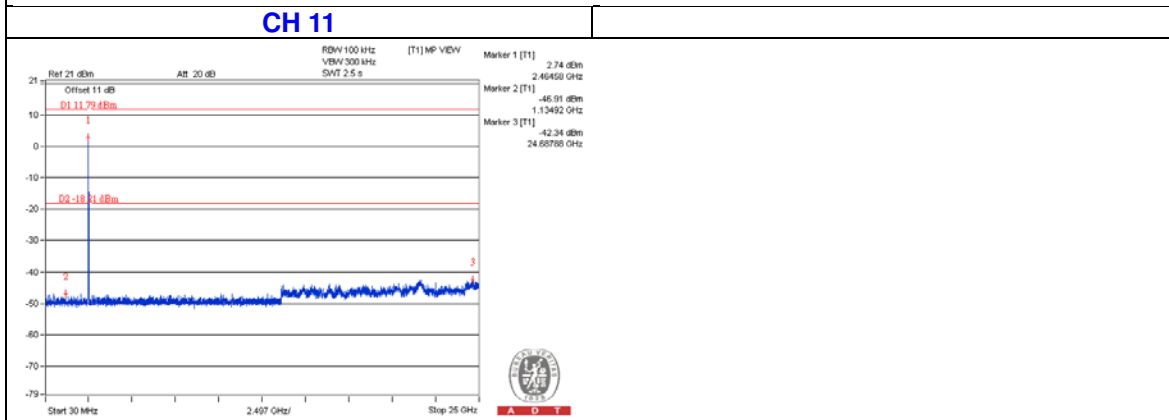
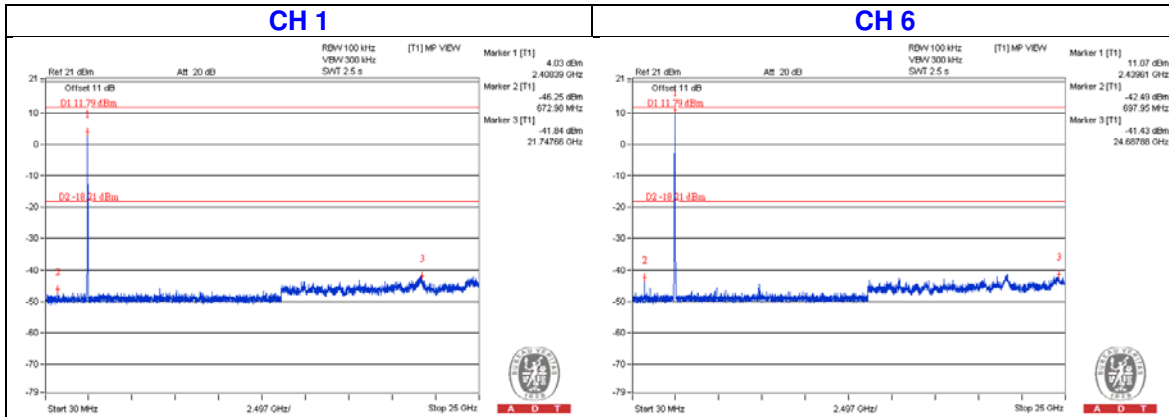

**1TX Mode**  
**802.11b**

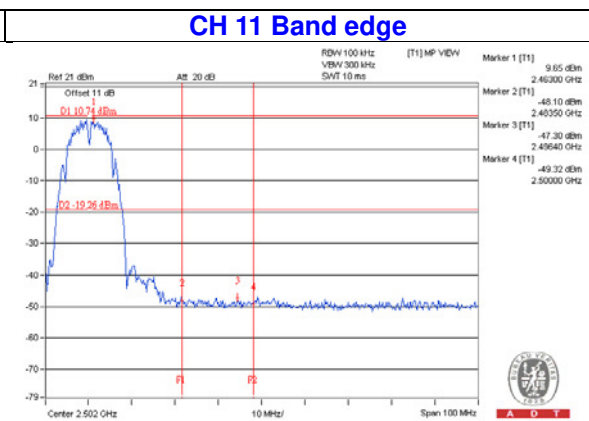
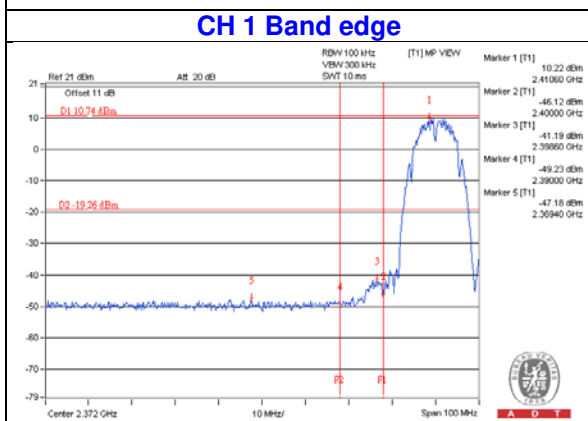
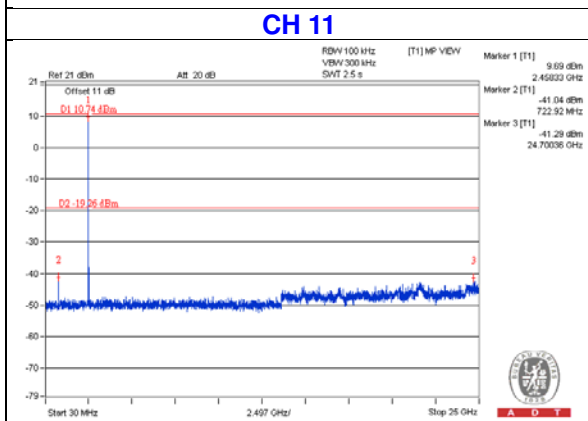
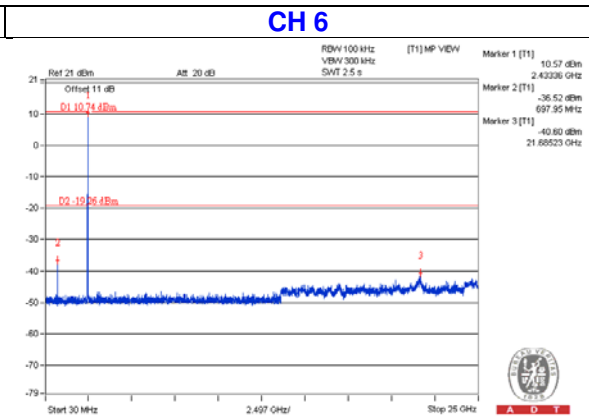
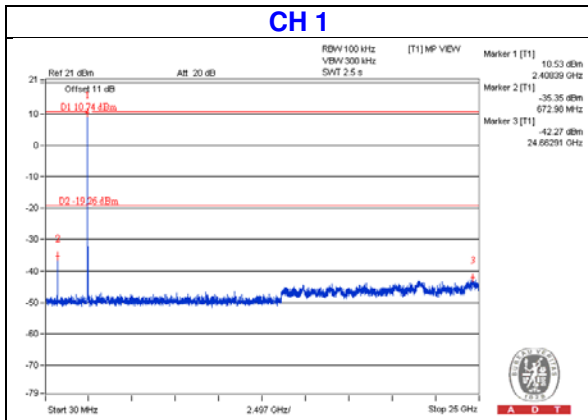
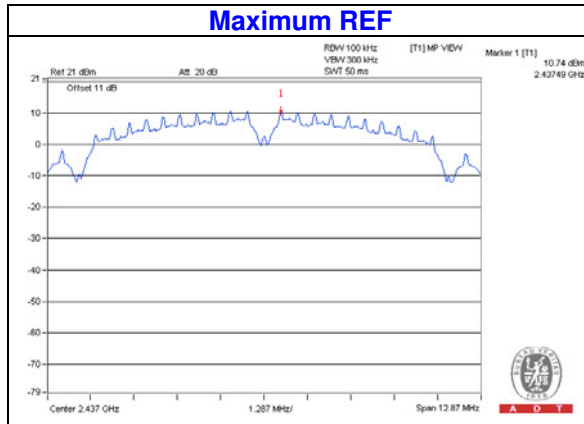



802.11g

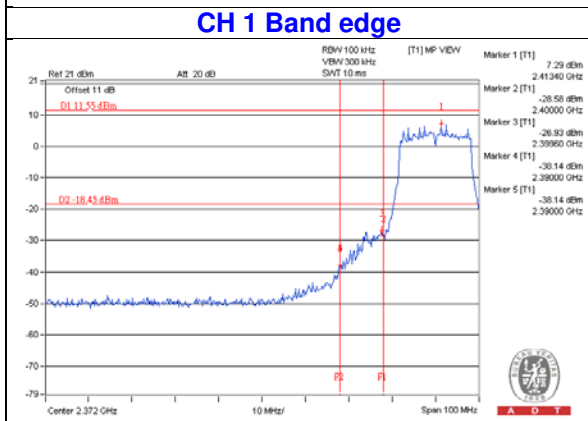
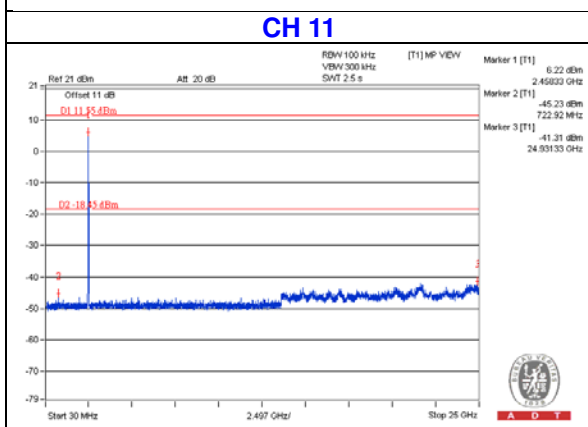
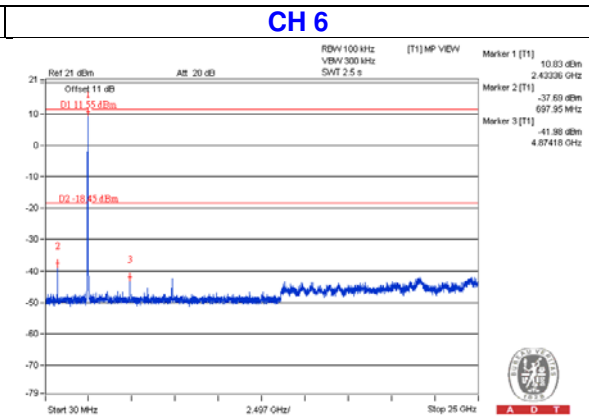
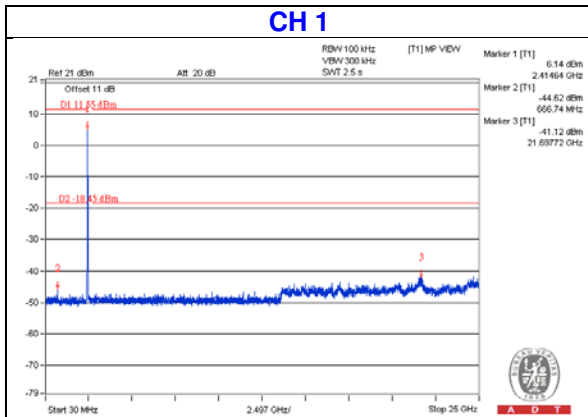
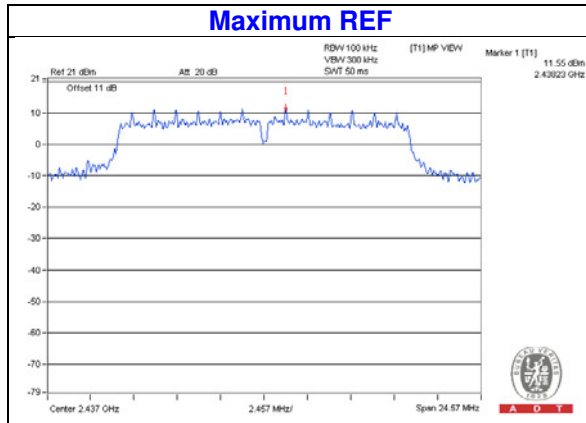

802.11n (HT20)

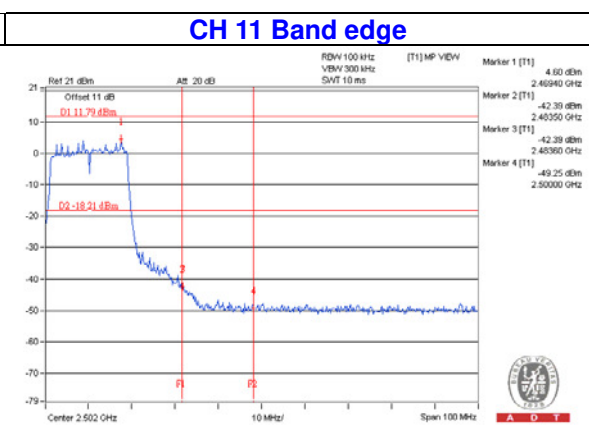
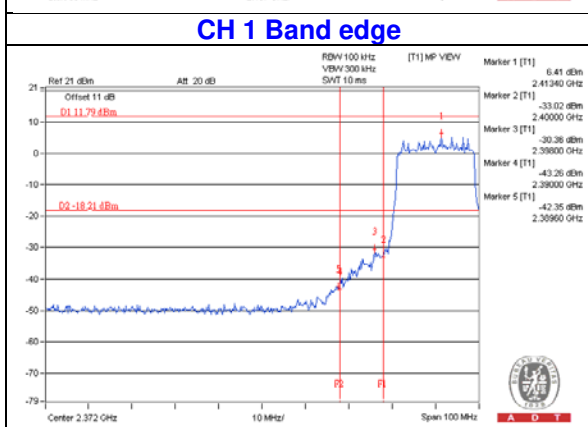
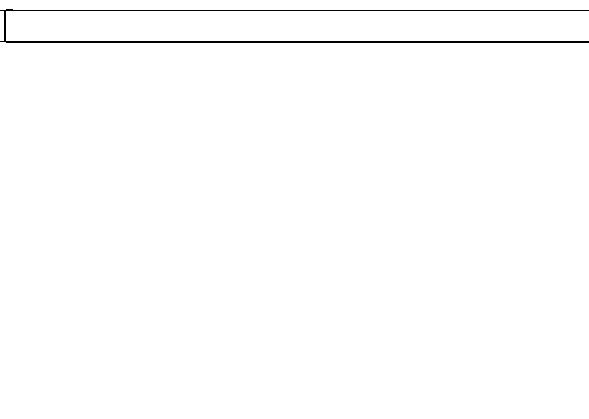
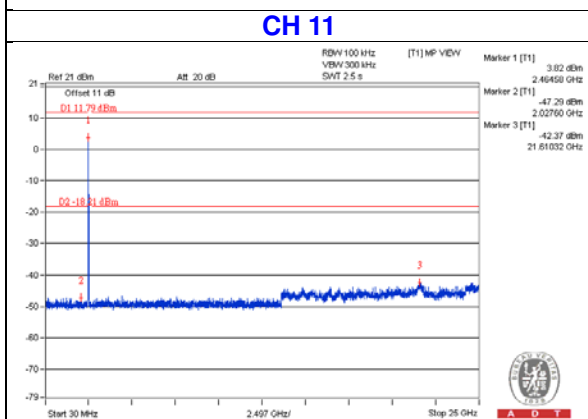
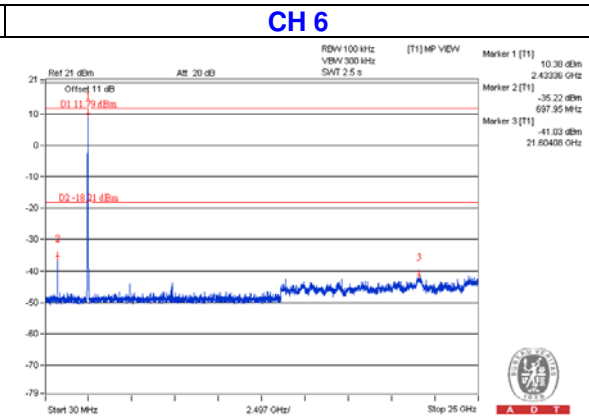
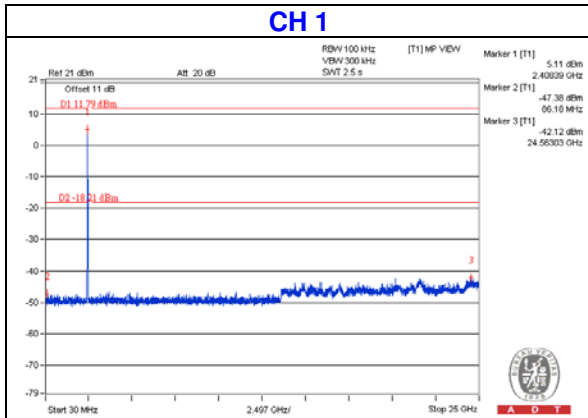
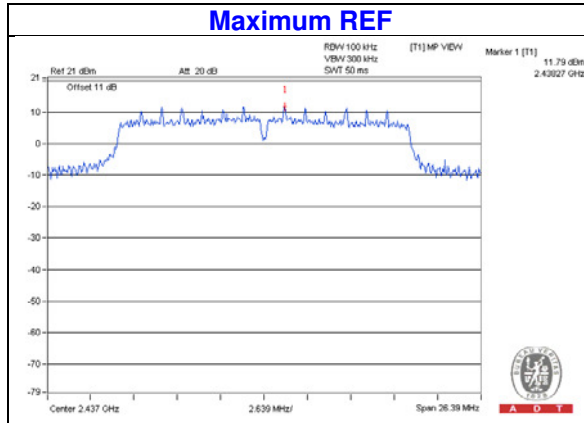

## 5 Pictures of Test Arrangements

Please refer to the attached file (Test Setup Photo).

## Appendix – Information on the Testing Laboratories

We, Bureau Veritas Consumer Products Services (H.K.) Ltd., Taoyuan Branch, were founded in 1988 to provide our best service in EMC, Radio, Telecom and Safety consultation. Our laboratories are accredited and approved according to ISO/IEC 17025.

If you have any comments, please feel free to contact us at the following:

**Linko EMC/RF Lab**

Tel: 886-2-26052180

Fax: 886-2-26051924

**Hsin Chu EMC/RF/Telecom Lab**

Tel: 886-3-6668565

Fax: 886-3-6668323

**Hwa Ya EMC/RF/Safety Lab**

Tel: 886-3-3183232

Fax: 886-3-3270892

**Email:** [service.adt@tw.bureauveritas.com](mailto:service.adt@tw.bureauveritas.com)

**Web Site:** [www.bureauveritas-adt.com](http://www.bureauveritas-adt.com)

The address and road map of all our labs can be found in our web site also.

--- END ---