



NVLAP LAB CODE 200707-0



FCC PART 27

MEASUREMENT AND TEST REPORT

For

Bravo Tech (Shenzhen) Co., Ltd.

No.8 Building, The 3rd Zone, Tangtou Industrial Park, Shiyan, Baoan District,
Shenzhen, Guangdong, P.R. of China

FCC ID: WBKMBSC081921-21

Report Type: Original Report	Product Type: Multi-Band, Multi-Standard, Multi-Carrier Coverage System (WCDMA 2100)
Test Engineer: Weir Zhong	<i>Weir Zhong</i>
Report Number: RSZ09121101-27	
Report Date: 2010-05-14	
Reviewed By: Merry Zhao	<i>Merry Zhao</i>
Prepared By: EMC Engineer	
Bay Area Compliance Laboratories Corp. (Shenzhen) 6/F, the 3rd Phase of WanLi Industrial Building, ShiHua Road, FuTian Free Trade Zone Shenzhen, Guangdong, China Tel: +86-755-33320018 Fax: +86-755-33320008	

Note: This test report is prepared for the customer shown above and for the device described herein. It may not be duplicated or used in part without prior written consent from Bay Area Compliance Laboratories Corp. This report **must not** be used by the customer to claim product certification, approval, or endorsement by NVLAP*, NIST, or any agency of the Federal Government.
* This report may contain data that are not covered by the NVLAP accreditation and are marked with an asterisk "*" (Rev.2)

TABLE OF CONTENTS

GENERAL INFORMATION.....	4
PRODUCT DESCRIPTION FOR EQUIPMENT UNDER TEST (EUT)	4
EUT PHOTO	4
OBJECTIVE	4
RELATED SUBMITTAL(S)/GRANT(S).....	5
TEST METHODOLOGY	5
TEST FACILITY	5
SYSTEM TEST CONFIGURATION.....	6
JUSTIFICATION	6
EQUIPMENT MODIFICATIONS	6
LOCAL SUPPORT EQUIPMENT LIST AND DETAILS	6
EXTERNAL I/O CABLE.....	6
CONFIGURATION OF TEST SETUP	7
BLOCK DIAGRAM OF TEST SETUP	7
SUMMARY OF TEST RESULTS	8
FCC §1.1307(B)(1) & §2.1091- MAXIMUM PERMISSIBLE EXPOSURE (MPE).....	9
STANDARD APPLICABLE	9
MPE PREDICATION	9
FCC §2.1047 - MODULATION CHARACTERISTIC.....	10
FCC § 2.1046, § 27.50(D) – EFFECTIVE RADIATED POWER.....	11
APPLICABLE STANDARD	11
TEST PROCEDURE	11
TEST EQUIPMENT LIST AND DETAILS.....	11
TEST DATA	11
FCC §2.1049 & §27.53(H) - 99% & -26 DB OCCUPIED BANDWIDTH.....	19
APPLICABLE STANDARDS REQUIREMENTS:.....	19
TEST PROCEDURE	19
TEST EQUIPMENT LIST AND DETAILS.....	19
TEST DATA	19
FCC §2.1051 & §27.53(H) - SPURIOUS EMISSIONS AT ANTENNA TERMINALS	33
APPLICABLE STANDARDS.....	33
TEST PROCEDURE	33
TEST EQUIPMENT LIST AND DETAILS.....	34
TEST DATA	34
FCC §2.1053&§27.53(H) - SPURIOUS RADIATED EMISSIONS	37
APPLICABLE STANDARDS.....	37
TEST PROCEDURE	37
TEST EQUIPMENT LIST AND DETAILS.....	37
TEST DATA	38
FCC §27.53(H) - BAND EDGES	40
APPLICABLE STANDARDS.....	40
TEST PROCEDURE	40
TEST EQUIPMENT LIST AND DETAILS.....	40

TEST DATA	41
FCC §2.1055 & §27.54 - FREQUENCY STABILITY.....	46
APPLICABLE STANDARD	46
TEST PROCEDURE	46
TEST EQUIPMENT LIST AND DETAILS.....	46
TEST DATA	47

GENERAL INFORMATION

Product Description for Equipment Under Test (EUT)

The *Bravo Tech (Shenzhen) Co., Ltd.*'s product, model number: *mBSC081921-12 (WCDMA 2100, FCC ID: WBKMBSC081921-21)* or the "EUT" as referred to in this report is a *Multi-Band, Multi-Standard, Multi-Carrier Coverage System*, which measures approximately: 50 cm L x 25 cm W x 12 cm H, rated input voltage: AC 120V power source.

Frequency Range:

AWS Band: 2110-2155 MHz (Downlink)

Transmitter Output Power:

AWS Band: 46±1 dBm (Downlink)

** All measurement and test data in this report was gathered from production sample serial number: 0912031 (Assigned by BACL). The EUT was received on 2009-12-11.*

EUT Photo



Please see additional photos in Exhibit B & C

Objective

This type approval report is prepared on behalf of *Bravo Tech (Shenzhen) Co., Ltd.* in accordance with Part 2, Part 27 of the Federal Communication Commissions rules.

The objective is to determine compliance with FCC rules for output power, modulation characteristic, occupied bandwidth, and spurious emission at antenna terminal, spurious radiated emission, frequency stability, band edge and radiated margin.

Related Submittal(s)/Grant(s)

None.

Test Methodology

All tests and measurements indicated in this document were performed in accordance with the Code of Federal Regulations Title 47 Part 2, Sub-part J as well as the following parts:

Part 27 – Miscellaneous wireless communications services

Applicable Standards: TIA-1037, TIA/EIA 603-C.

All radiated and conducted emissions measurements were performed at Bay Area Compliance Laboratories Corp. The radiated testing was performed at an antenna-to-EUT distance of 3 meters.

Test Facility

The Test site used by Bay Area Compliance Laboratories Corp.(Shenzhen) to collect test data is located in the 6/F, the 3rd Phase of WanLi Industrial Building, ShiHua Road, FuTian Free Trade Zone Shenzhen, Guangdong, China.

Test site at Bay Area Compliance Laboratories Corp. (Shenzhen) has been fully described in reports submitted to the Federal Communication Commission (FCC). The details of these reports have been found to be in compliance with the requirements of Section 2.948 of the FCC Rules on November 21, 2007. The facility also complies with the radiated and AC line conducted test site criteria set forth in ANSI C63.4-2003.

The Federal Communications Commission has the reports on file and is listed under FCC Registration No.: 382179. The test site has been approved by the FCC for public use and is listed in the FCC Public Access Link (PAL) database.

Additionally, Bay Area Compliance Laboratories Corp. (Shenzhen) is a National Institute of Standards and Technology (NIST) accredited laboratory, under the National Voluntary Laboratory Accredited Program (Lab Code 200707-0).



NVLAP LAB CODE 200707-0

The current scope of accreditations can be found at <http://ts.nist.gov/Standards/scopes/2007070.htm>

SYSTEM TEST CONFIGURATION

Justification

The EUT was configured for testing according to TIA/EIA-603-C.

The final qualification test was performed with the EUT operating at normal mode.

Equipment Modifications

No modifications were made to the EUT.

Local Support Equipment List and Details

Manufacturer	Description	Model	Serial Number	FCC ID
AEROFLEX	Signal Generator	IFR3416	3410051025	N/A
ASTEC	DC Power Supply	JF101B-9000-0000	BY4748	N/A
IBM	Laptop	T400	GTVQC-2KWCD-VXM8V-KPRM9-KKVDB	DoC
Bravo	Host Unit	mBSC081921-12 (Host Unit)	N/A	N/A

External I/O Cable

Cable Description	Length (m)	From/Port	To
Unshielded Detachable AC Cable	7.0	LISN / AC mains	EUT
Unshielded Detachable Fiber Cable	1.2	Host Unit / Fiber Port	Remote Unit (AWS 2100 Unit)
Shielded Detachable Blue RF Cable	1.5	Host Unit / SMA Port	Remote Unit
Shielded Detachable Yellow RF Cable	3.0	Signal Generator / SMA Port	Remote Unit
Unshielded Detachable DC Cable	1.3	DC Supply / DC Port	Host Unit
Unshielded Detachable Network Cable	10.0	Laptop / Network Port	Host Unit

Configuration of Test Setup

For Downlink mode- CDMA AWS Band:

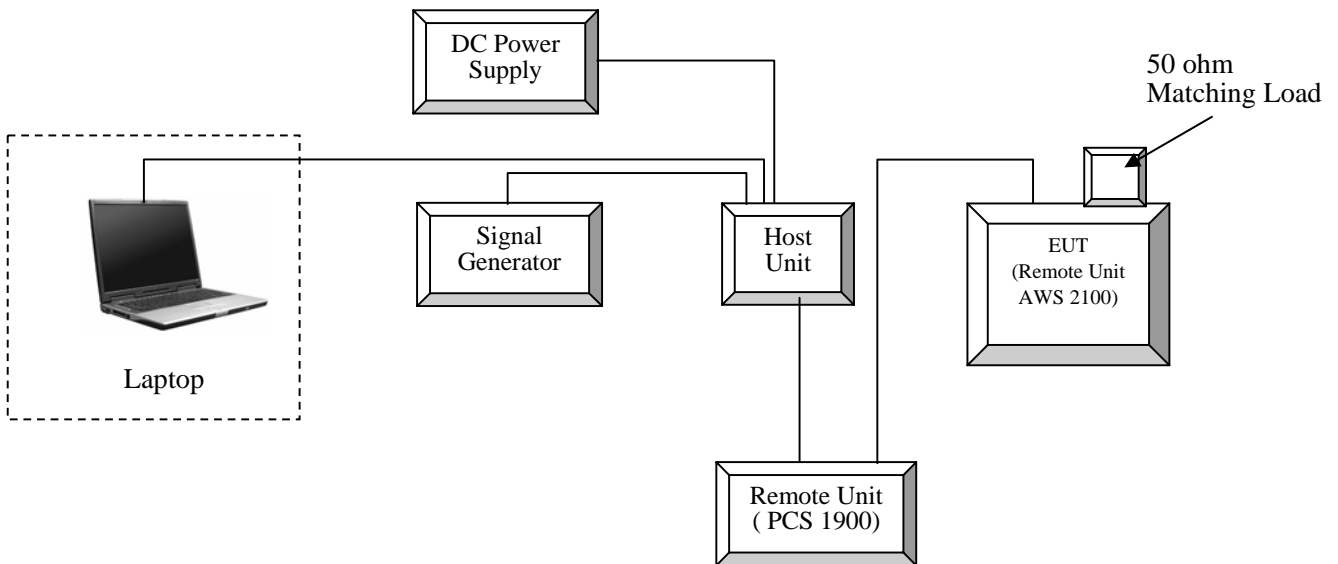

Block Diagram of Test Setup

For Downlink mode- CDMA AWS Band:

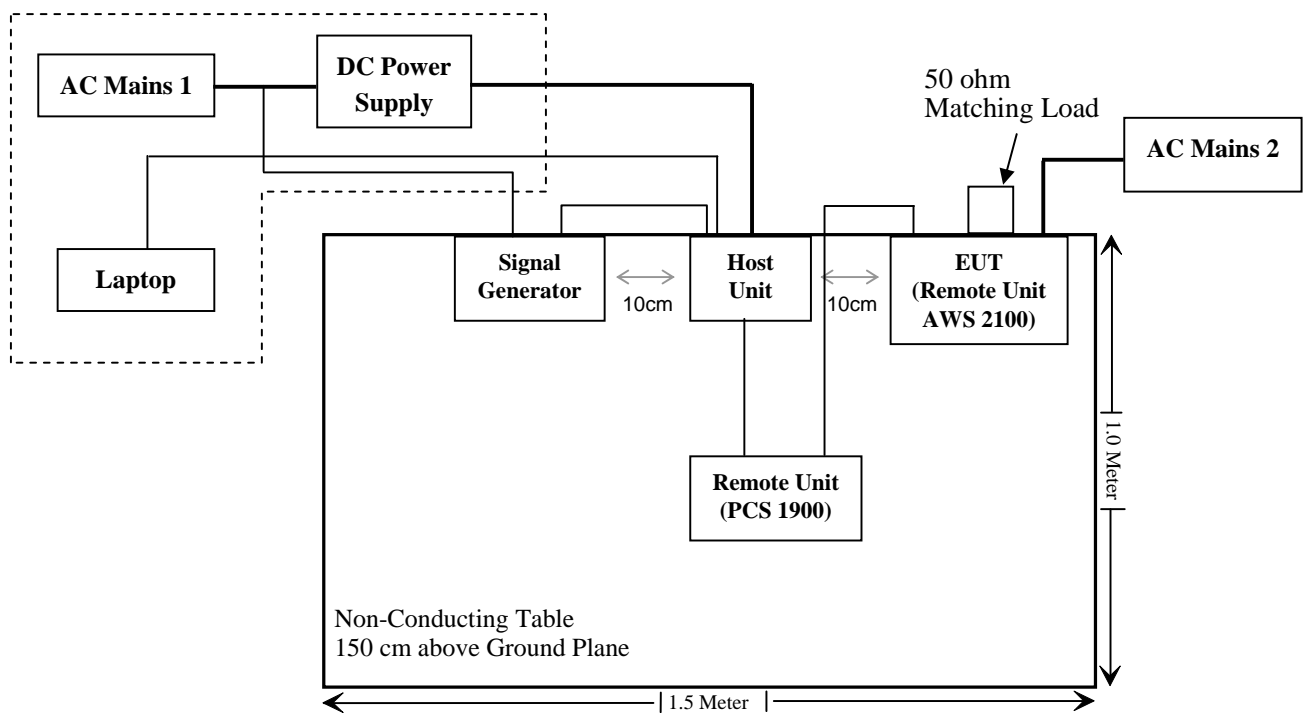

SUMMARY OF TEST RESULTS

FCC Rules	Description of Test	Result
§1.1307 (b)(1), §2.1091	Maximum Permissible exposure (MPE)	Compliant
§2.1047	Modulation Characteristics	N/A
§2.1046; §27.50(d)	Effective Radiated Power	Compliant
§2.1049; §27.53(h)	99% & -26 dB Occupied Bandwidth	Compliant
§2.1051; §27.53(h)	Spurious Emissions at Antenna Terminal	Compliant
§2.1053; §27.53(h)	Spurious Radiation Emission	Compliant
§27.53(h)	Band Edge	Compliant
§2.1055; §27.54	Frequency stability vs. temperature Frequency stability vs. voltage	Compliant

FCC §1.1307(b)(1) & §2.1091- MAXIMUM PERMISSIBLE EXPOSURE (MPE)**Standard Applicable**

According to subpart 1.1307 (b)(1), 2.1091 systems operating under the provisions of this section shall be operated in a manner that ensures the public is not exposed to RF energy level in excess of the communication guidelines.

Limits for Occupational/Controlled Exposures

Limits for Occupational/Controlled Exposures				
Frequency Range (MHz)	Electric Field Strength (V/m)	Magnetic Field Strength (A/m)	Power Density (mw/cm ²)	Averaging Time (Minutes)
0.3-3.0	614	1.63	*(100)	6
3.0-30.0	1824/f	4.89/f	*(900/f ²)	6
30-300	61.4	0.163	1.0	6
300-1500	/	/	f/300	6
1500-100,000	/	/	5.0	6

f = frequency in MHz

* = Plane-wave equivalent power density

MPE Predication

Predication of MPE limit at a given distance

$$S = PG/4\pi R^2$$

Where:

S = power density (in appropriate units, e.g. mW/cm²)

P = power input to the antenna (in appropriate units, e.g., mW).

G = power gain of the antenna in the direction of interest relative to an isotropic radiator, the power gain factor, is normally *numeric* gain.

R = distance to the center of radiation of the antenna (appropriate units, e.g., cm)

Maximum peak output power at antenna input terminal: 45.92(dBm)

Maximum peak output power at antenna input terminal: 39084.09 (mW)

Prediction distance: 400 (cm)

Predication frequency: 2115 (MHz)

Antenna Gain (typical): 11(dBi)

Antenna Gain (typical): 12.59 (numeric)

Power density predication frequency at 400 cm: 0.24mW/cm²

MPE limit for general population exposure at prediction frequency: 5 (mW/cm²)

Result: compliant

FCC §2.1047 - MODULATION CHARACTERISTIC

According to FCC §2.1047(d), Part 27 C there is no specific requirement for digital modulation, therefore modulation characteristic is not presented.

FCC § 2.1046, § 27.50(d) – EFFECTIVE RADIATED POWER

Applicable Standard

FCC §2.1046 and §27.50(d),

Test Procedure

Conducted method:

The RF output port of the EUT system was connected to the wireless test set and the EMI test receiver through sufficient attenuation.

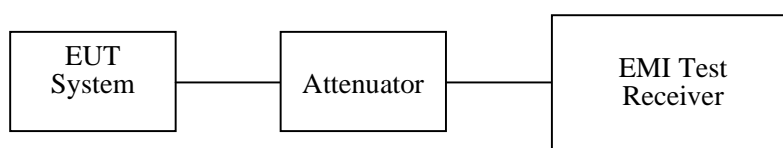

Test Equipment List and Details

Manufacturer	Description	Model	Serial Number	Calibration Date	Calibration Due Date
Rohde & Schwarz	EMI test receiver	ESCI	100224	2009-11-24	2010-11-23

* **Statement of Traceability:** Bay Area Compliance Laboratories Corp. (Shenzhen) attests that all calibrations have been performed in accordance to NVLAP requirements, traceable to the NIST.

Test Data

Environmental Conditions

Temperature:	25 °C
Relative Humidity:	56 %
ATM Pressure:	100.0kPa

The testing was performed by Weir Zhong on 2010-01-08 to 2010-04-28.

CDMA AWS Band (Part 27):

Mode	Channel	Frequency (MHz)	Output Power (dBm)	Result
Downlink	One Carrier			
	Low	2112.5	45.57	Compliant
	Middle	2132.5	45.65	Compliant
	High	2152.5	45.79	Compliant
	Two Carriers			
	Low	2115.0	45.61	Compliant
	Middle	2132.5	45.71	Compliant
	High	2150.0	45.67	Compliant
	Three Carriers			
	Low	2117.5	45.59	Compliant
	Middle	2132.5	45.75	Compliant
	High	2147.5	45.69	Compliant
	Four Carriers			
	Low	2120.0	45.90	Compliant
	Middle	2132.5	45.91	Compliant
	High	2145.0	45.92	Compliant

Note: The antenna gain is 11 dBi.

Plots of Conducted Output Power

Downlink mode (One carrier):

Low Channel

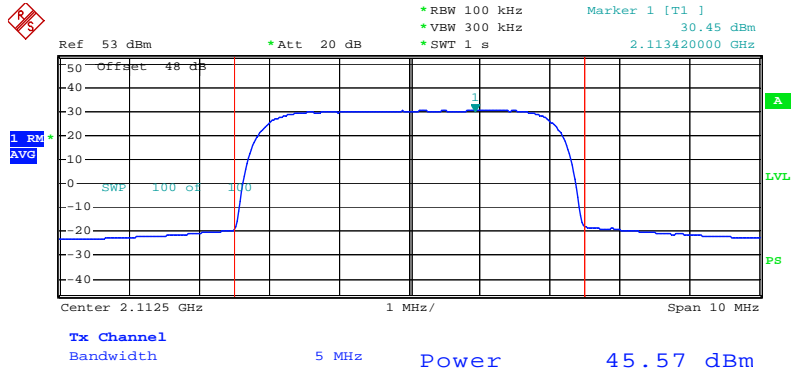

Date: 8.JAN.2010 08:48:21

Middle Channel

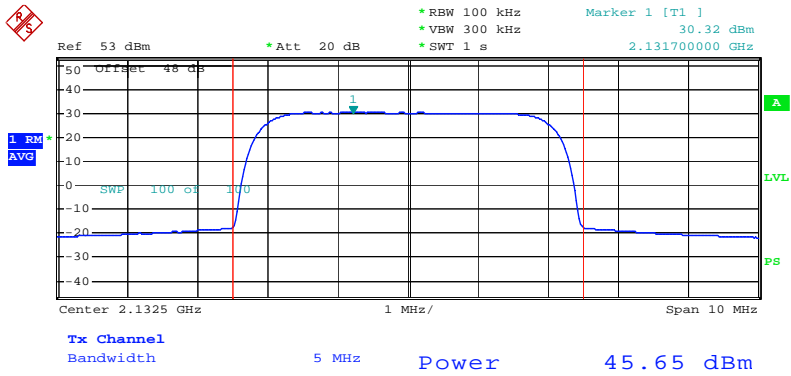

Date: 8.JAN.2010 08:37:50

High Channel

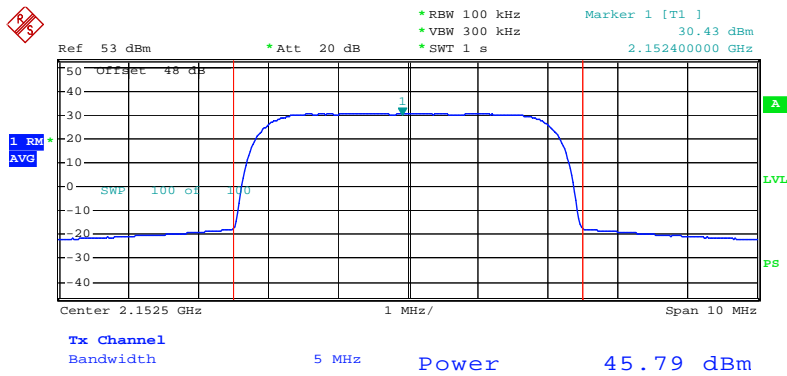

Date: 8.JAN.2010 08:51:03

Downlink mode (Two carriers):

Low Channel

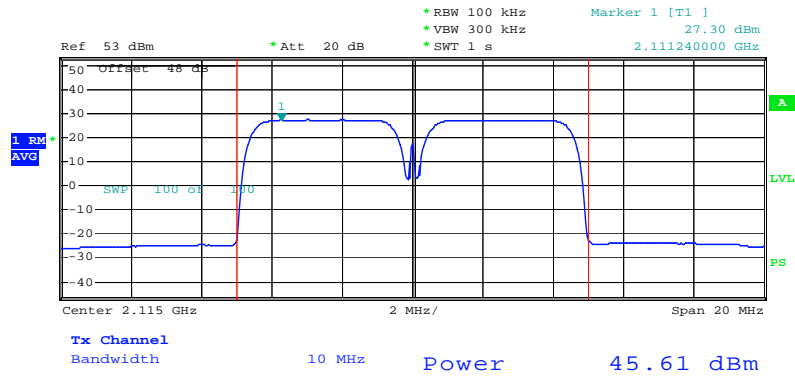

Date: 28.APR.2010 11:16:49

Middle Channel

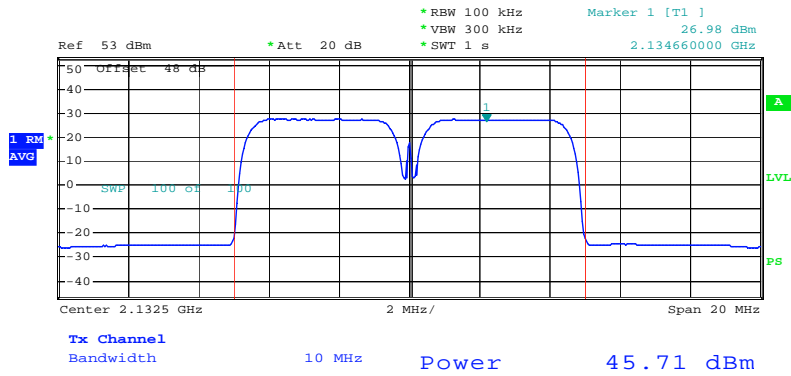

Date: 28.APR.2010 10:12:44

High Channel

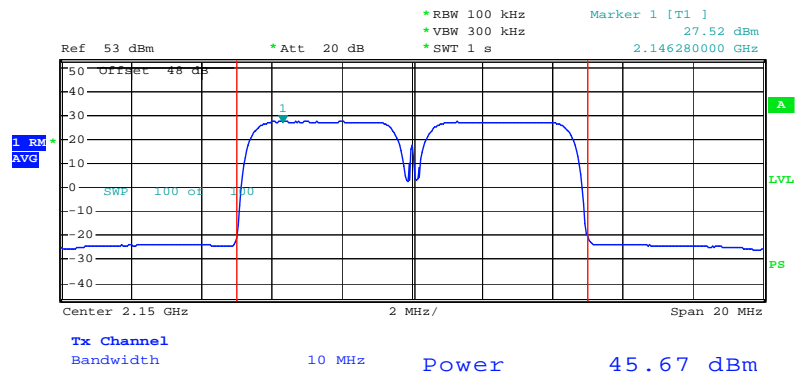

Date: 28.APR.2010 11:23:18

Downlink mode (Three carriers):

Low Channel

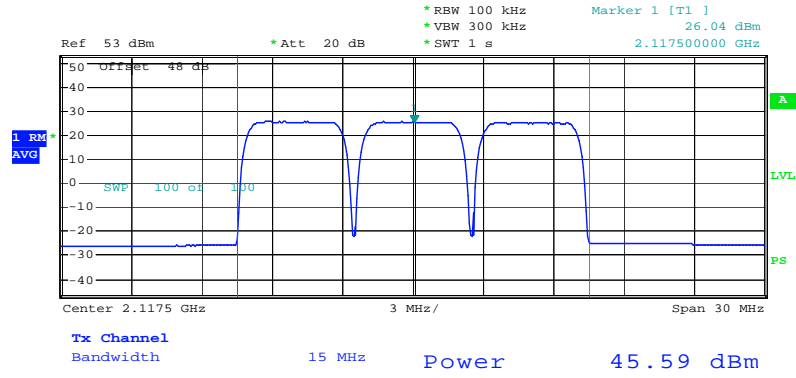

Date: 28.APR.2010 11:03:39

Middle Channel

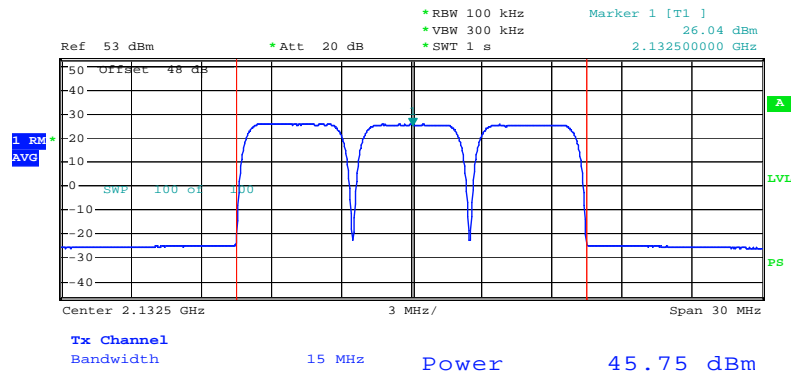

Date: 28.APR.2010 10:35:12

High Channel

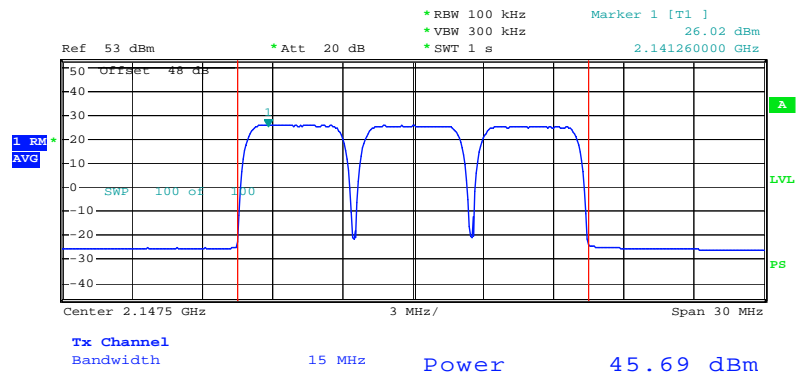

Date: 28.APR.2010 11:09:04

Downlink mode (Four carriers):

Low Channel

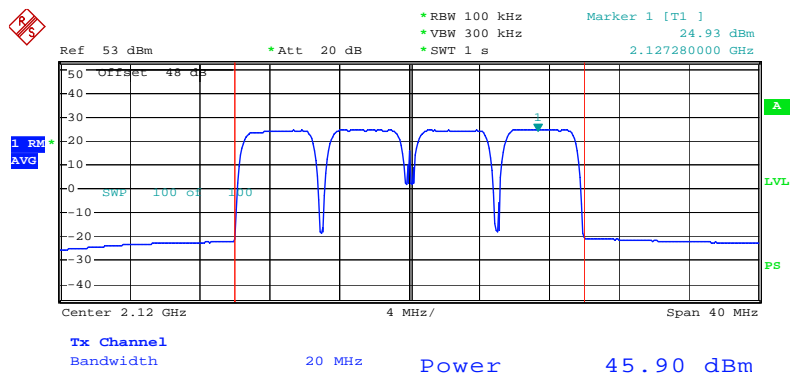

Date: 8.JAN.2010 09:22:48

Middle Channel

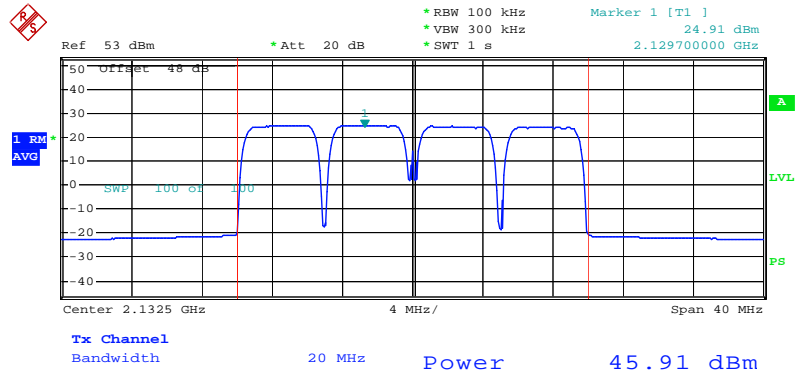

Date: 8.JAN.2010 09:13:38

High Channel

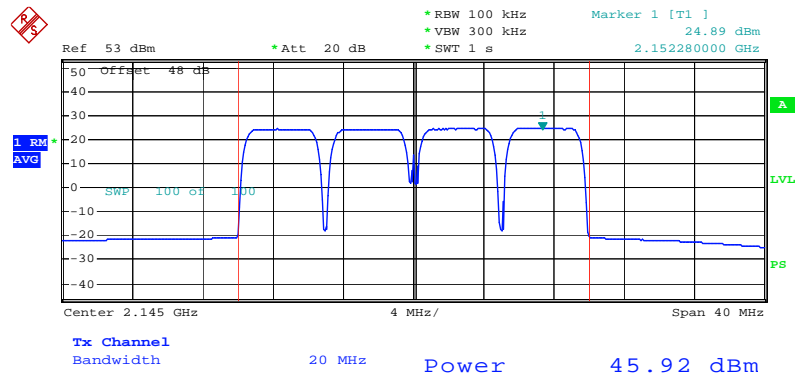

Date: 8.JAN.2010 09:25:25

FCC §2.1049 & §27.53(h) - 99% & -26 dB OCCUPIED BANDWIDTH

Applicable Standards Requirements:

FCC §2.1049 & §27.53(h)

The emission bandwidth is defined as the width of the signal between two points, one below the carrier center frequency and one above the carrier center frequency, outside of which all emissions are attenuated at least 26 dB below the transmitter power.

Test Procedure

The RF output of the EUT system was connected to the simulator and the EMI test receiver through sufficient attenuation.

The resolution bandwidth of the EMI test receiver was set at 100 kHz (Cellular /PCS) and the 26 dB & 99% bandwidth was recorded.

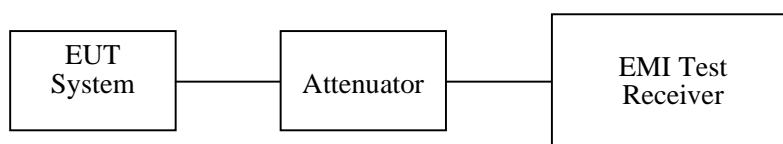

Test Equipment List and Details

Manufacturer	Description	Model	Serial Number	Calibration Date	Calibration Due Date
Rohde & Schwarz	EMI Test Receiver	ESCI	100224	2009-11-24	2010-11-23

* **Statement of Traceability:** Bay Area Compliance Laboratories Corp. (Shenzhen) attests that all calibrations have been performed in accordance to NVLAP requirements, traceable to the NIST.

Test Data

Environmental Conditions

Temperature:	25 °C
Relative Humidity:	56%
ATM Pressure:	100.0kPa

The testing was performed by Weir Zhong on 2010-01-08 to 2010-04-28.

Mode	Channel	Frequency (MHz)	99% Occupied Bandwidth (MHz)	26 dB Occupied Bandwidth (MHz)
Downlink	One Carrier			
	Low	2112.5	4.18	4.70
	Mid	2132.5	4.18	4.72
	High	2152.5	4.20	4.72
	Two Carriers			
	Low	2115.0	9.04	9.76
	Mid	2132.5	9.04	9.76
	High	2150.0	9.04	9.76
	Three Carriers			
	Low	2117.5	13.92	14.76
	Mid	2132.5	13.95	14.76
	High	2147.5	13.92	14.76
	Four Carriers			
	Low	2120.0	18.88	19.84
	Mid	2132.5	18.88	19.84
	High	2145.0	18.88	19.84

Please refer to the following plots.

Downlink mode (One carrier):

99% Occupied Bandwidth

Low Channel

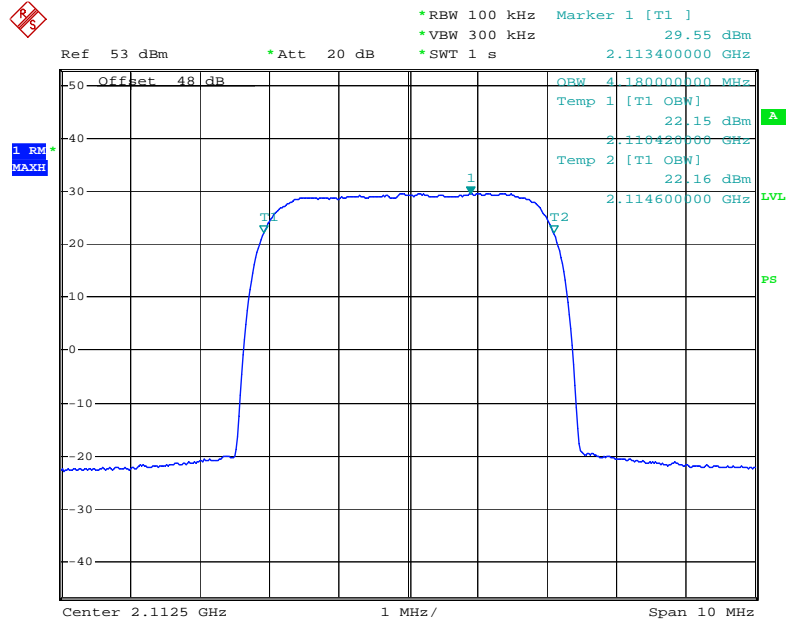

Date: 8.JAN.2010 09:04:34

Middle Channel

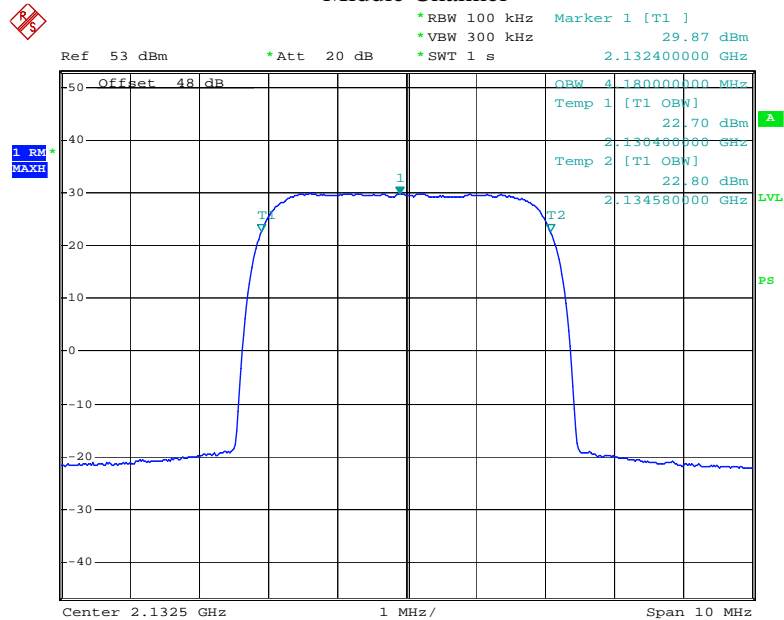

Date: 8.JAN.2010 09:06:00

High Channel

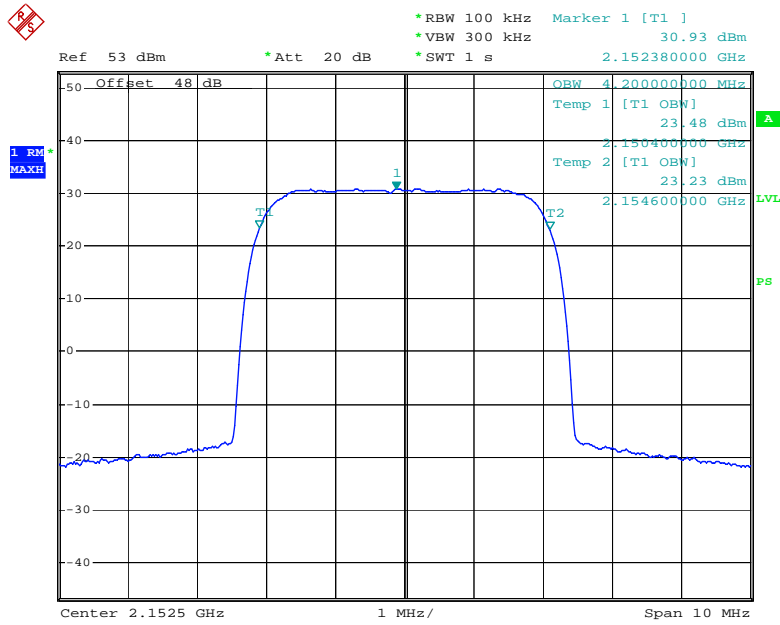

Date: 8.JAN.2010 08:58:14

26 dB Occupied Bandwidth

Low Channel

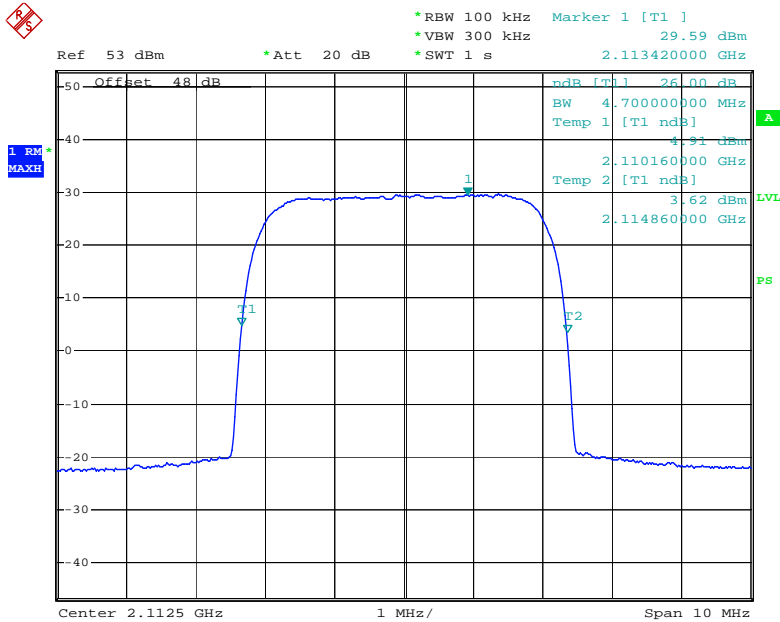

Date: 8.JAN.2010 09:03:53

Middle Channel

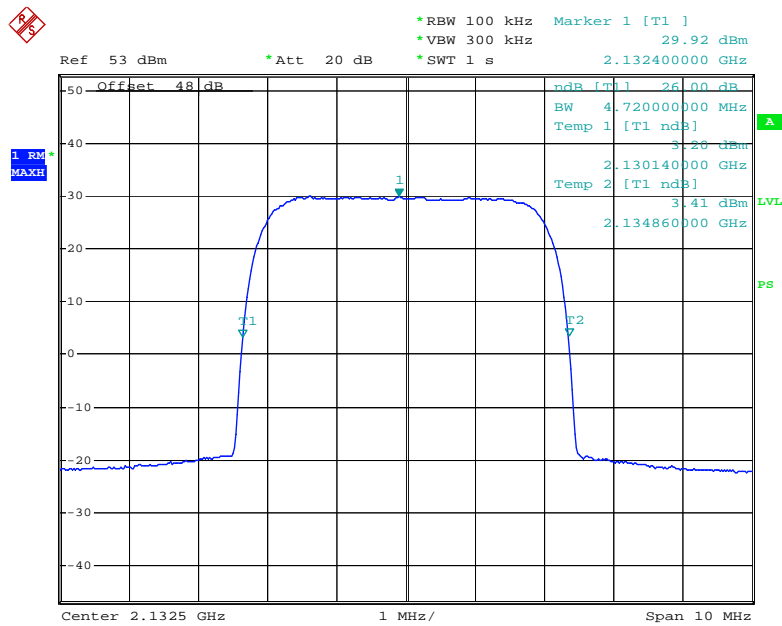

Date: 8.JAN.2010 09:06:22

High Channel

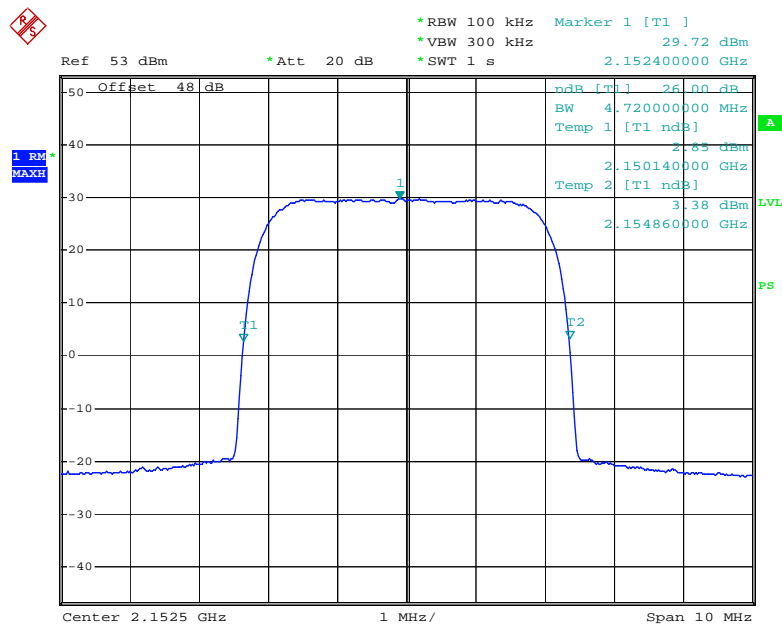

Date: 8.JAN.2010 08:59:21

Downlink mode (Two carriers):

99% Occupied Bandwidth

Low Channel

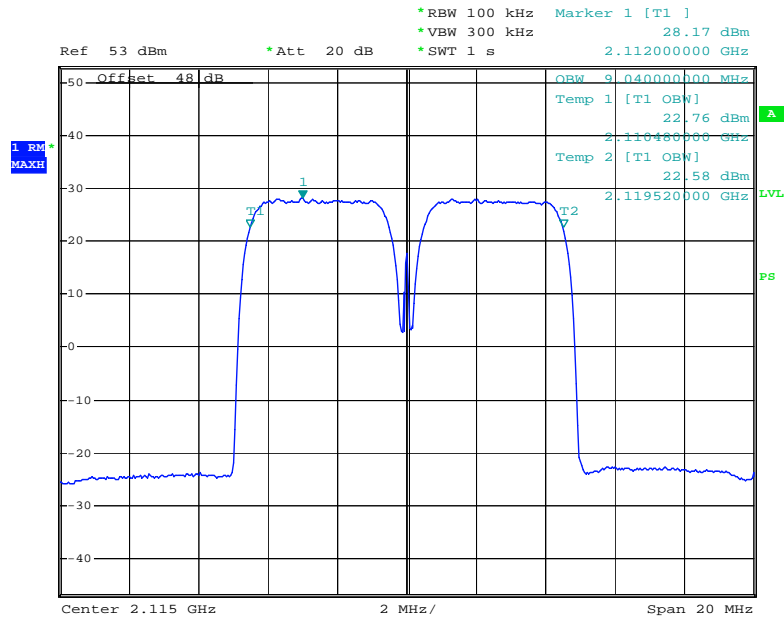

Date: 28.APR.2010 11:17:19

Middle Channel

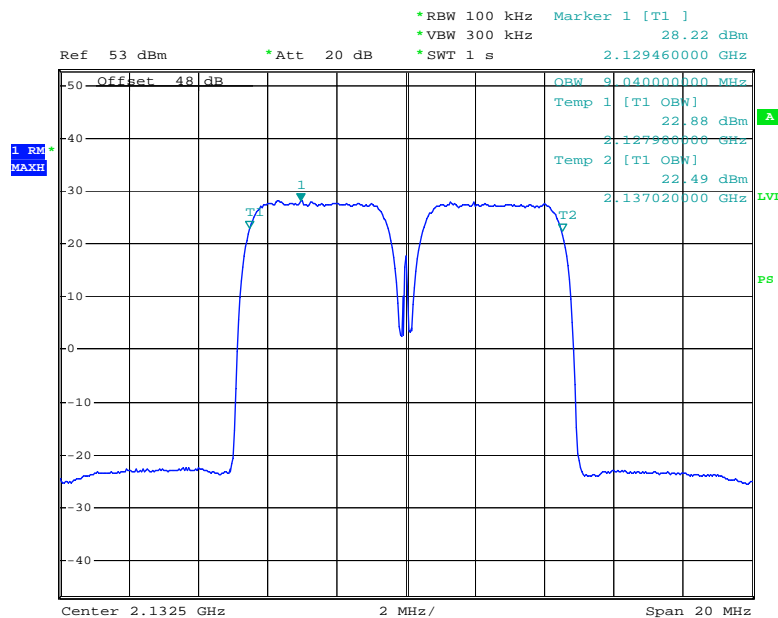

Date: 28.APR.2010 11:19:59

High Channel

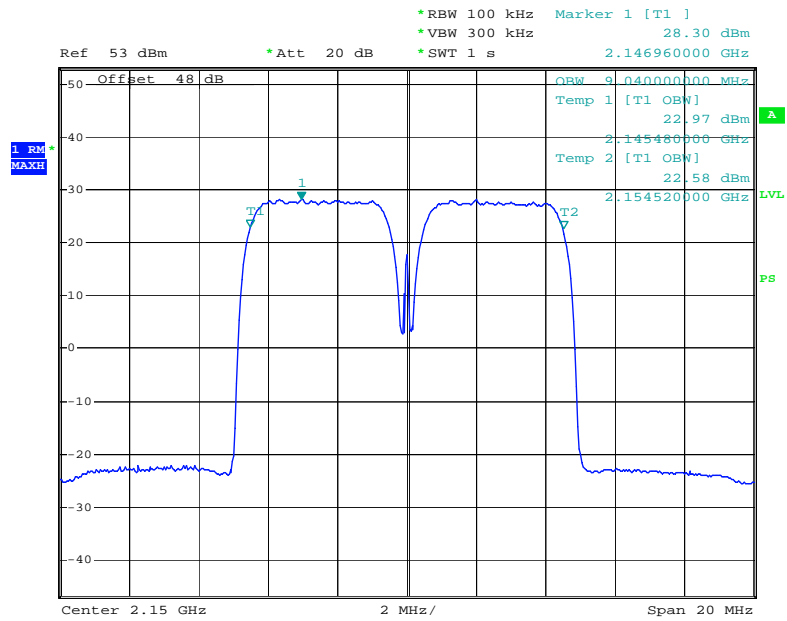

Date: 28.APR.2010 11:23:44

26 dB Occupied Bandwidth

Low Channel

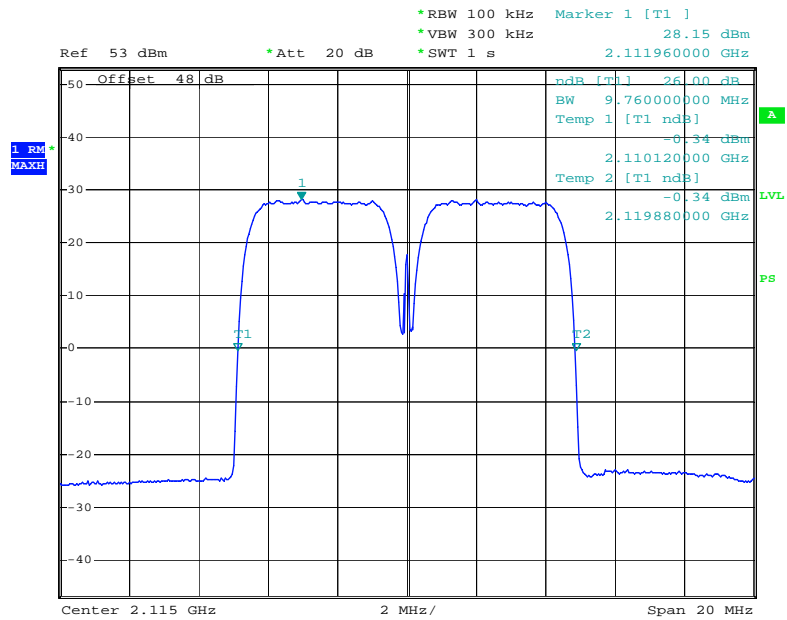

Date: 28.APR.2010 11:17:46

Downlink mode (Three carriers):

99% Occupied Bandwidth

Low Channel

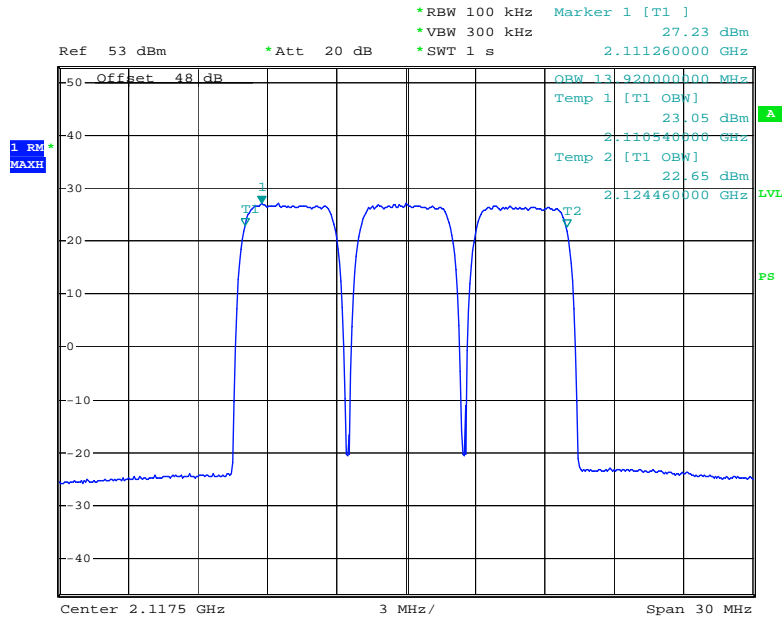

Date: 28.APR.2010 10:58:51

Middle Channel

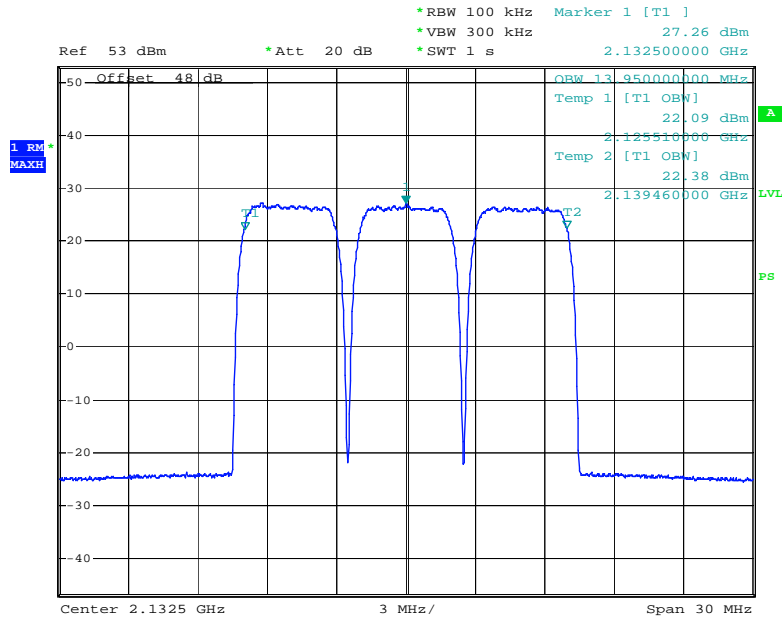

Date: 28.APR.2010 10:37:13

High Channel

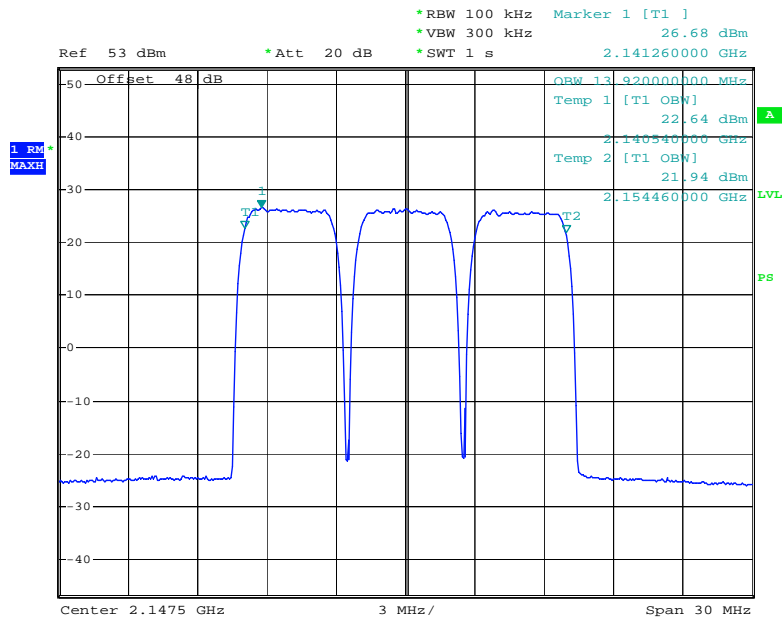

Date: 28.APR.2010 11:09:40

26 dB Occupied Bandwidth

Low Channel

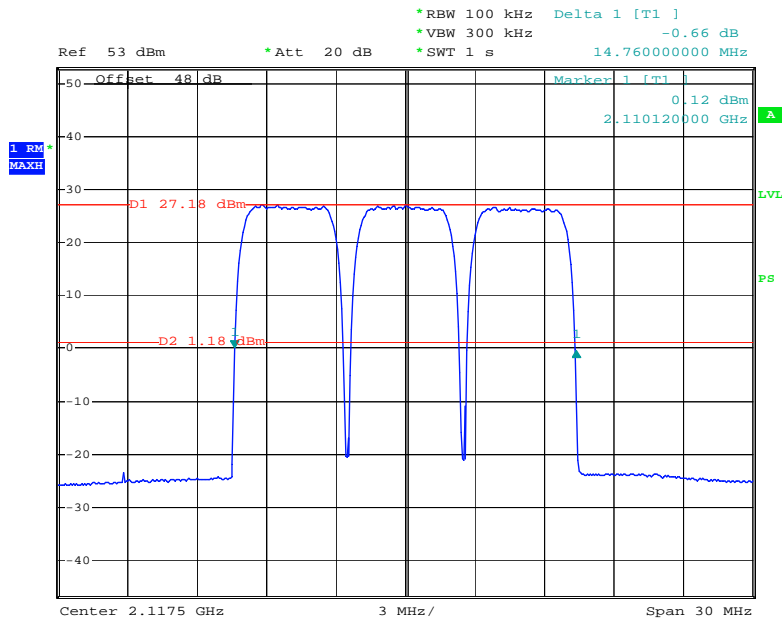

Date: 28.APR.2010 10:57:43

Middle Channel

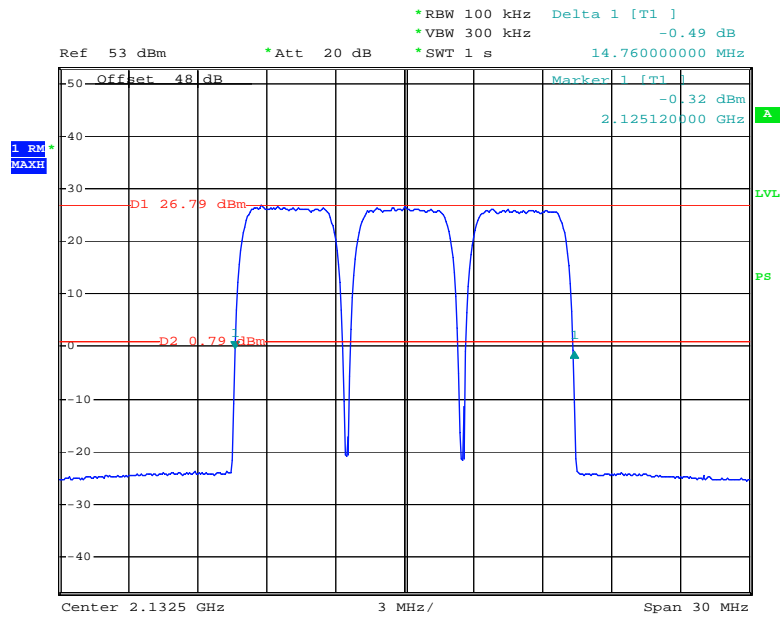

Date: 28.APR.2010 10:56:10

High Channel

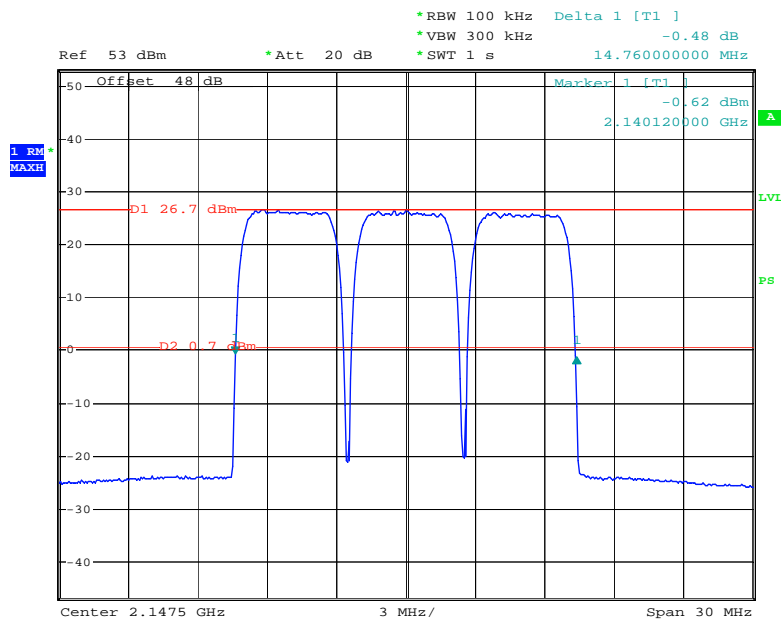

Date: 28.APR.2010 11:10:50

Downlink mode (Four carriers):

99% Occupied Bandwidth

Low Channel

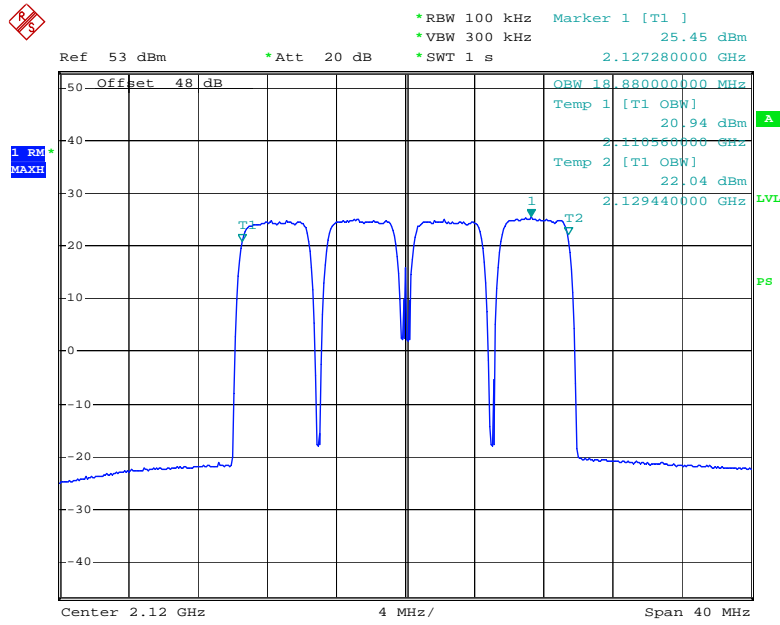

Date: 8.JAN.2010 09:37:31

Middle Channel

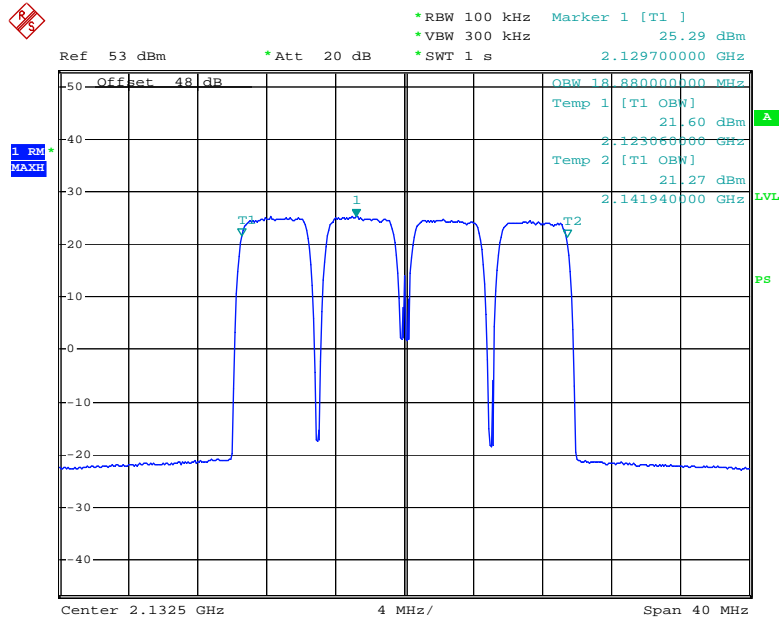

Date: 8.JAN.2010 09:43:28

High Channel

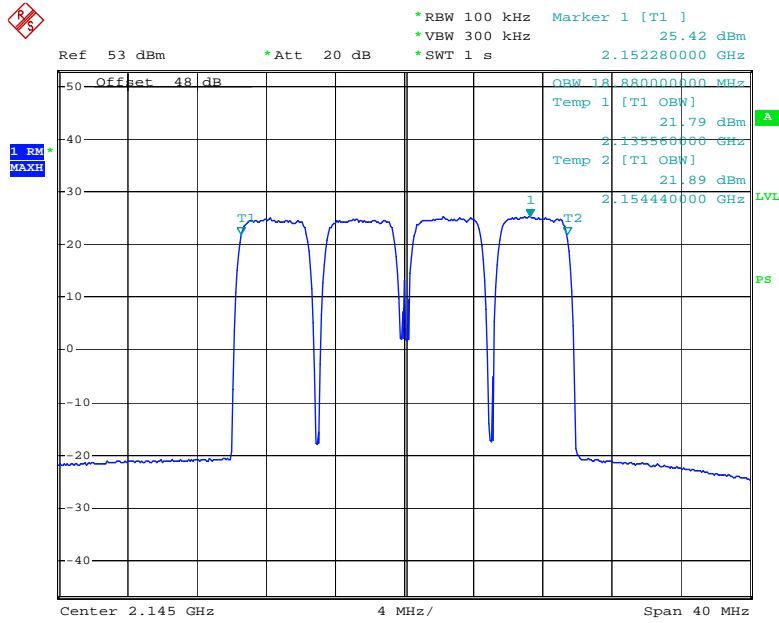

Date: 8.JAN.2010 09:28:47

26 dB Occupied Bandwidth

Low Channel

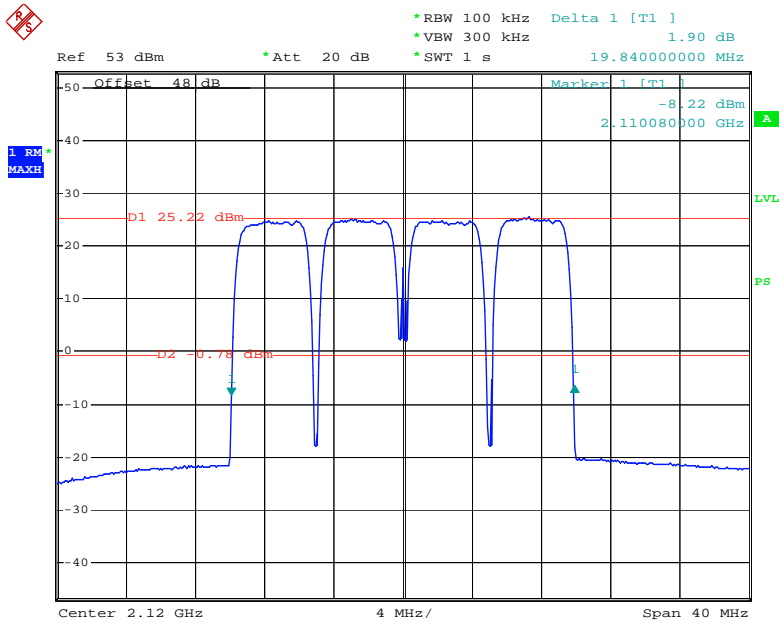

Date: 8.JAN.2010 09:39:14

Middle Channel

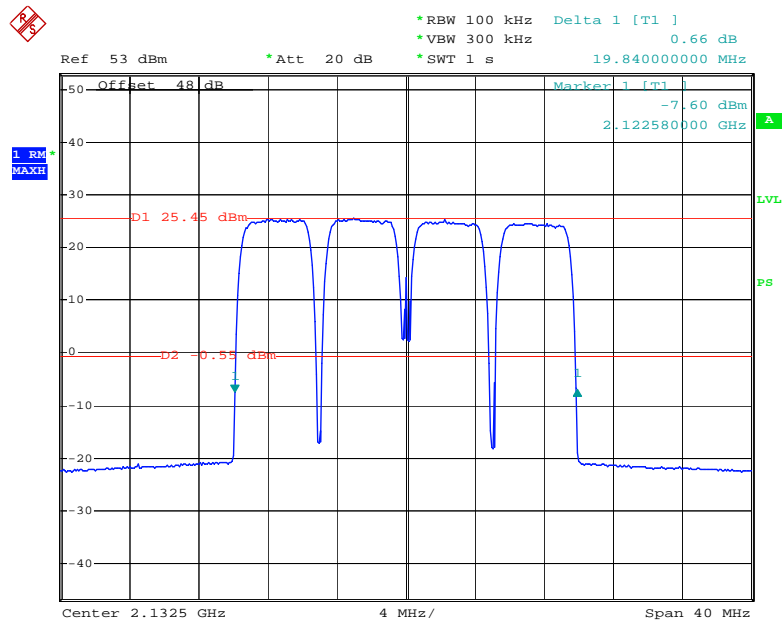

Date: 8.JAN.2010 09:42:48

High Channel

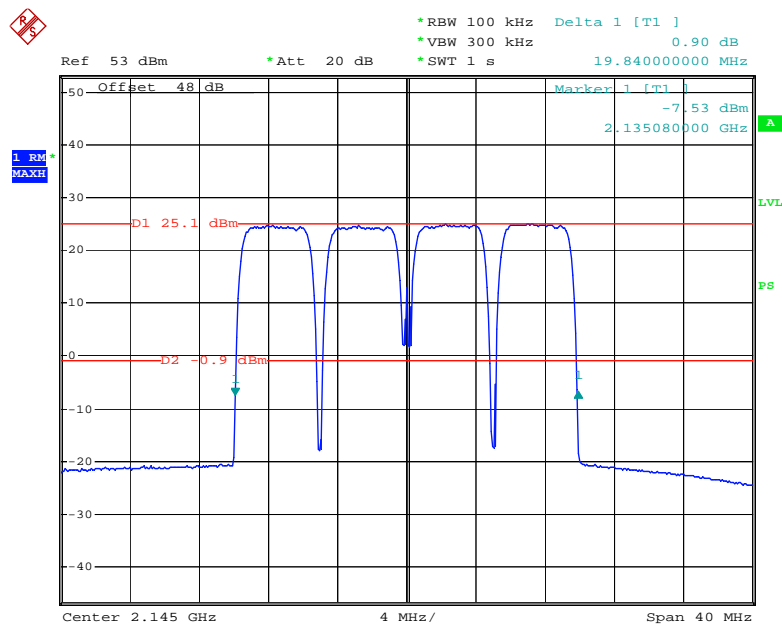

Date: 8.JAN.2010 09:41:01

FCC §2.1051 & §27.53(h) - SPURIOUS EMISSIONS AT ANTENNA TERMINALS

Applicable Standards

FCC §2.1051, §27.53(h).

h) For operations in the 1710–1755 MHz and 2110–2155 MHz bands, the power of any emission outside a licensee's frequency block shall be attenuated below the transmitter power (P) by at least $43 + 10 \log_{10}(P)$ dB.

(1) Compliance with this provision is based on the use of measurement instrumentation employing a resolution bandwidth of 1 megahertz or greater. However, in the 1 megahertz bands immediately outside and adjacent to the licensee's frequency block, a resolution bandwidth of at least one percent of the emission bandwidth of the fundamental emission of the transmitter may be employed. The emission bandwidth is defined as the width of the signal between two points, one below the carrier center frequency and one above the carrier center frequency, outside of which all emissions are attenuated at least 26 dB below the transmitter power.

(2) When measuring the emission limits, the nominal carrier frequency shall be adjusted as close to the licensee's frequency block edges, both upper and lower, as the design permits.

(3) The measurements of emission power can be expressed in peak or average values, provided they are expressed in the same parameters as the transmitter power.

The spectrum was to be investigated to the tenth harmonics of the highest fundamental frequency as specified in § 2.1051.

Test Procedure

The RF output of the EUT system was connected to a spectrum analyzer and simulator through appropriate attenuation. The resolution bandwidth of the EMI test receiver was set at as following table. Sufficient scans were taken to show any out of band emissions up to 10th harmonic.

Frequency	RBW	VBW
9 ~ 150 kHz	1 kHz	3 kHz
150 kHz ~ 30 MHz	10 kHz	30 kHz
30 MHz ~ 1 GHz	100 kHz	300 kHz
Above 1 GHz	1 MHz	3 MHz

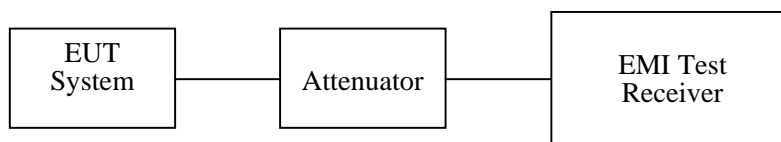

Test Equipment List and Details

Manufacturer	Description	Model	Serial Number	Calibration Date	Calibration Due Date
Rohde & Schwarz	Spectrum Analyzer	FSEM30	849720/019	2009-07-08	2010-07-07
Rohde & Schwarz	EMI Test Receiver	ESCI	100224	2009-11-24	2010-11-23

* **Statement of Traceability:** Bay Area Compliance Laboratories Corp. (Shenzhen) attests that all calibrations have been performed in accordance to NVLAP requirements, traceable to the NIST.

Test Data

Environmental Conditions

Temperature:	25 °C
Relative Humidity:	56 %
ATM Pressure:	100.0kPa

The testing was performed by Weir Zhong on 2009-12-20 to 2009-12-22.

Downlink mode (worse case):

9 kHz – 150 kHz - Middle Channel

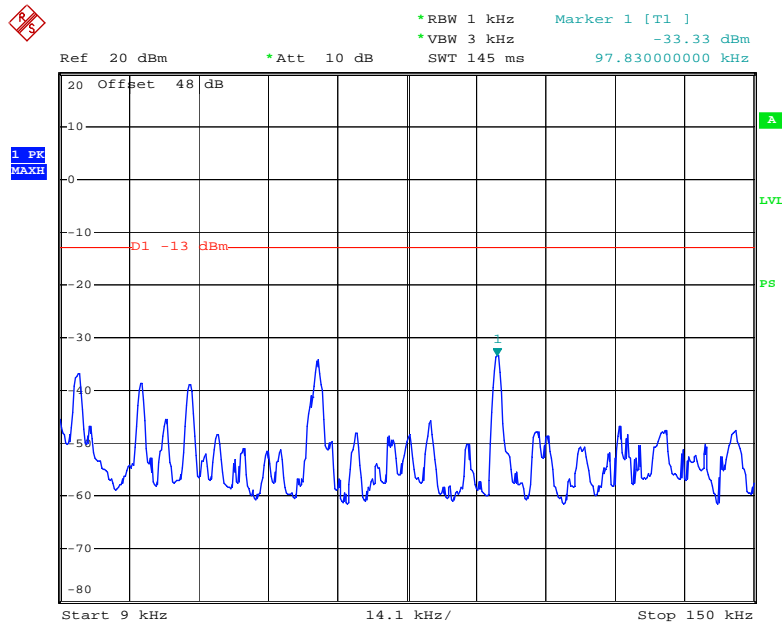

Date: 22.DEC.2009 01:23:24

150 kHz – 30 MHz - Middle Channel

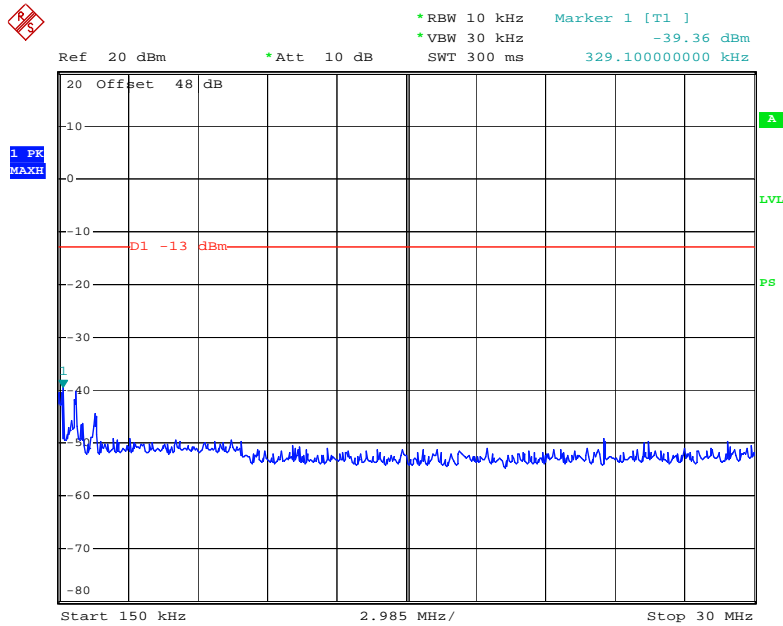

Date: 22.DEC.2009 01:23:51

30 – 1000 MHz - Middle Channel

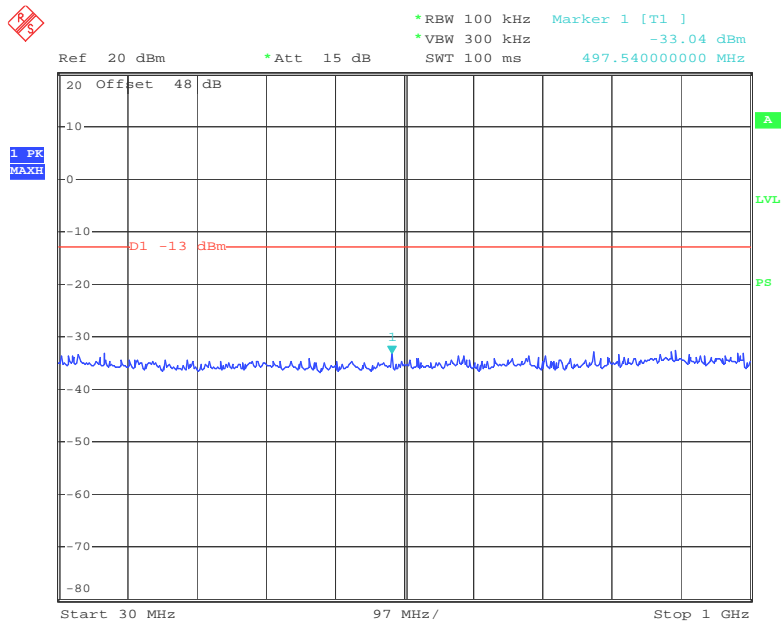

Date: 22.DEC.2009 01:24:32

1 – 22 GHz - Middle Channel

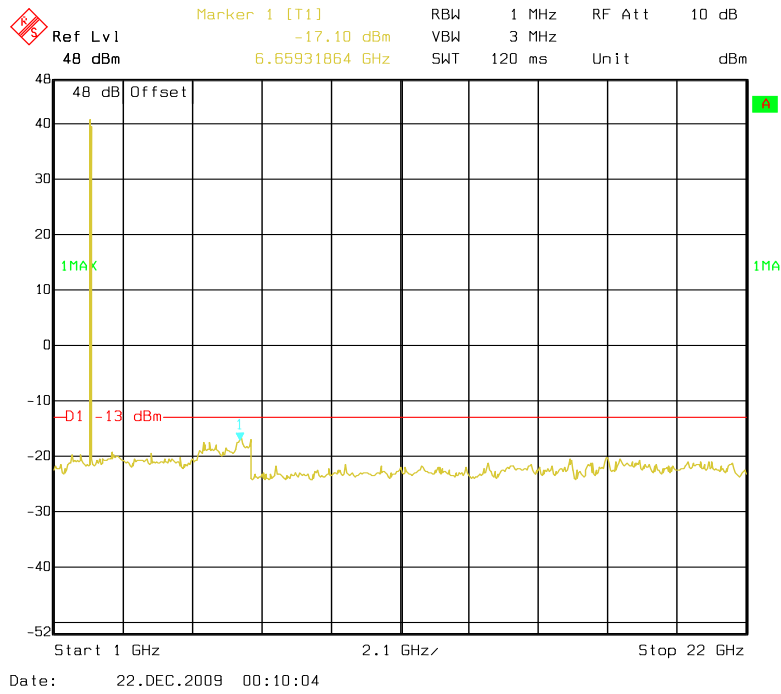

FCC §2.1053&§27.53(h) - SPURIOUS RADIATED EMISSIONS

Applicable Standards

FCC §2.1053 & §27.53(h)

Test Procedure

The EUT system was placed on a wooden turntable, and it was transmitting into a non-radiating load which was also placed on the turntable.

The measurement antenna was placed at a distance of 3 meters from the EUT. During the tests, the antenna height and polarization as well as EUT azimuth were varied in order to identify the maximum level of emissions from the EUT. The test was performed by placing the EUT on 3-orthogonal axis.

The frequency range up to tenth harmonic of the fundamental frequency was investigated.

Remove the EUT and replace it with substitution antenna. A signal generator was connected to the substitution antenna by a non-radiating cable. The absolute levels of the spurious emissions were measured by the substitution.

Spurious emissions in dB = 10 lg (TXpwr in Watts/0.001) – the absolute level

Spurious attenuation limit in dB = 43 + 10 Log₁₀ (power out in Watts)

Test Equipment List and Details

Manufacturer	Description	Model	Serial Number	Calibration Date	Calibration Due Date
Sunol Sciences	Horn Antenna	DRH-118	A052604	2009-05-05	2010-05-04
Sunol Sciences	Broadband Antenna	JB1	A040904-1	2010-03-11	2011-03-11
Rohde & Schwarz	Spectrum Analyzer	FSEM30	849720/019	2009-07-08	2010-07-07
HP	Preamplifier	8449B	3008A00277	2009-09-12	2010-09-11
HP	Signal Generator	HP8657A	2849U00982	2009-10-28	2010-10-27
HP	Amplifier	HP8447D	2944A09795	2009-08-02	2010-08-02
HP	Synthesized Sweeper	8341B	2624A00116	2009-11-07	2010-11-06
COM POWER	Dipole Antenna	AD-100	041000	2009-09-25	2010-09-25
A.H. System	Horn Antenna	SAS-200/571	135	2009-05-17	2010-05-17

* **Statement of Traceability:** Bay Area Compliance Laboratories Corp. (Shenzhen) attests that all calibrations have been performed in accordance to NVLAP requirements, traceable to the NIST.

Test Data

Environmental Conditions

Temperature:	25 °C
Relative Humidity:	56 %
ATM Pressure:	100.0kPa

The testing was performed by Weir Zhong on 2010-04-28.

Two tone Intermodulation:

In the band 2107.5 MHz- 2157.5 MHz, intermodulation products levels as follows and the max level are less than -13 dBm;

Set the operating frequency to 2132.5 MHz, and the other input signal at 2137.5 MHz

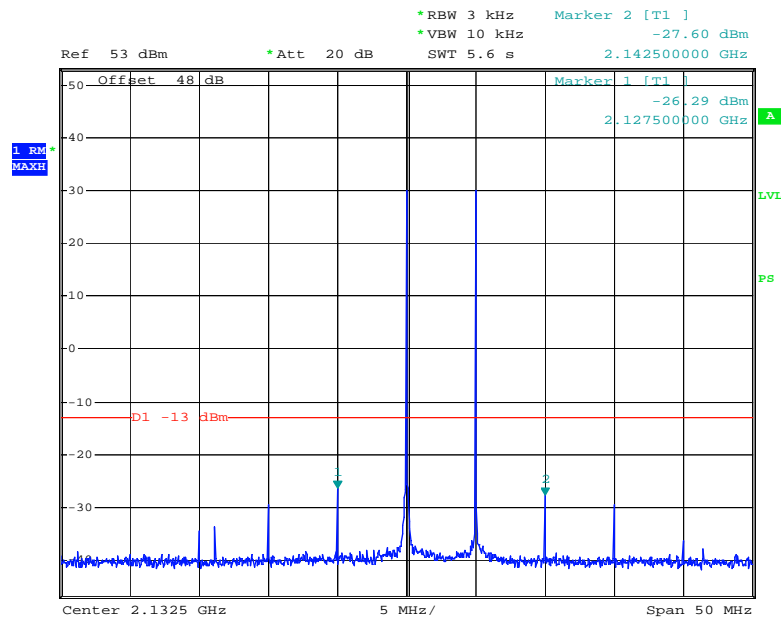

Date: 28.APR.2010 14:33:53

Test Mode: Downlink mode (worse case)

Indicated		Table Angle Degree	Test Antenna		Substituted				Absolute Level (dBm)	Limit (dBm)	Margin (dB)
Frequency (MHz)	S.A. Reading (dB μ V)		Height (m)	Polar (H/V)	Frequency (MHz)	Level (dBm)	Ant. Gain (dBi)	Cable Loss (dB)			
30 MHz -22 GHz Middle Channel											
37.28	62.72	72	1.0	V	37.28	-31.8	0	0.20	-32.00	-13	19.00
47.65	58.85	174	1.1	V	47.65	-37.8	0	0.22	-38.02	-13	25.02
6665.21	45.25	360	1.5	V	6665.21	-44.9	8.6	1.97	-38.27	-13	25.27
6655.31	44.95	186	1.8	H	6655.31	-45.4	8.6	1.97	-38.77	-13	25.77
80.64	56.01	272	1.0	V	80.64	-40.2	0	0.25	-40.45	-13	27.45
3156.19	45.57	185	1.1	V	3156.19	-52.9	7.0	1.31	-47.21	-13	34.21
3146.29	46.57	145	1.4	H	3146.29	-53.1	7.0	1.31	-47.41	-13	34.41
1136.27	48.41	281	1.5	H	1136.27	-53.1	6.0	0.78	-47.88	-13	34.88
1146.17	48.41	312	1.2	V	1146.17	-54.8	6.0	0.78	-49.58	-13	36.58
85.29	39.68	172	1.2	H	85.29	-59.0	0	0.25	-59.25	-13	46.25
171.99	35.48	357	1.0	H	171.99	-59.1	0	0.30	-59.40	-13	46.40
40.27	32.09	158	1.4	H	40.27	-64.2	0	0.22	-64.42	-13	51.42

FCC §27.53(h) - BAND EDGES

Applicable Standards

According to § 27.53(h), For operations in the 1710–1755 MHz and 2110–2155 MHz bands, the power of any emission outside a licensee's frequency block shall be attenuated below the transmitter power (P) by at least $43 + 10 \log_{10}(P)$ dB.

(1) Compliance with this provision is based on the use of measurement instrumentation employing a resolution bandwidth of 1 megahertz or greater. However, in the 1 megahertz bands immediately outside and adjacent to the licensee's frequency block, a resolution bandwidth of at least one percent of the emission bandwidth of the fundamental emission of the transmitter may be employed. The emission bandwidth is defined as the width of the signal between two points, one below the carrier center frequency and one above the carrier center frequency, outside of which all emissions are attenuated at least 26 dB below the transmitter power.

(2) When measuring the emission limits, the nominal carrier frequency shall be adjusted as close to the licensee's frequency block edges, both upper and lower, as the design permits.

(3) The measurements of emission power can be expressed in peak or average values, provided they are expressed in the same parameters as the transmitter power.

Test Procedure

The RF output of the EUT system was connected to the input of the EMI test receiver through sufficient attenuation.

The center of the EMI test receiver was set to block edge frequency, RBW set to 10 kHz.

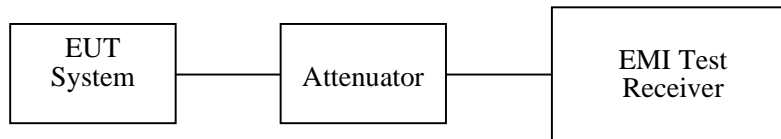

Test Equipment List and Details

Manufacturer	Description	Model	Serial Number	Calibration Date	Calibration Due Date
Rohde & Schwarz	EMI Test Receiver	ESCI	100224	2009-11-24	2010-11-23

* **Statement of Traceability:** Bay Area Compliance Laboratories Corp. (Shenzhen) attests that all calibrations have been performed in accordance to NVLAP requirements, traceable to the NIST.

Test Data**Environmental Conditions**

Temperature:	25 °C
Relative Humidity:	56 %
ATM Pressure:	100.0kPa

The testing was performed by Weir Zhong on 2010-01-08 to 2010-04-28.

Please refer to the following tables and plots.

Mode	Channel	Frequency (MHz)	Emission (dBm)	Limit (dBm)
Downlink	One Carrier			
	Lowest	2110.0	-19.60	-13
	Highest	2155.0	-19.54	-13
	Two Carriers			
	Lowest	2110	-22.46	-13
	Highest	2155	-19.77	-13
	Three Carriers			
	Lowest	2110	-22.12	-13
	Highest	2155	-22.03	-13
	Four Carrier			
	Lowest	2110.0	-21.22	-13
	Highest	2155.0	-19.65	-13

Downlink mode (One carrier), Lowest Channel

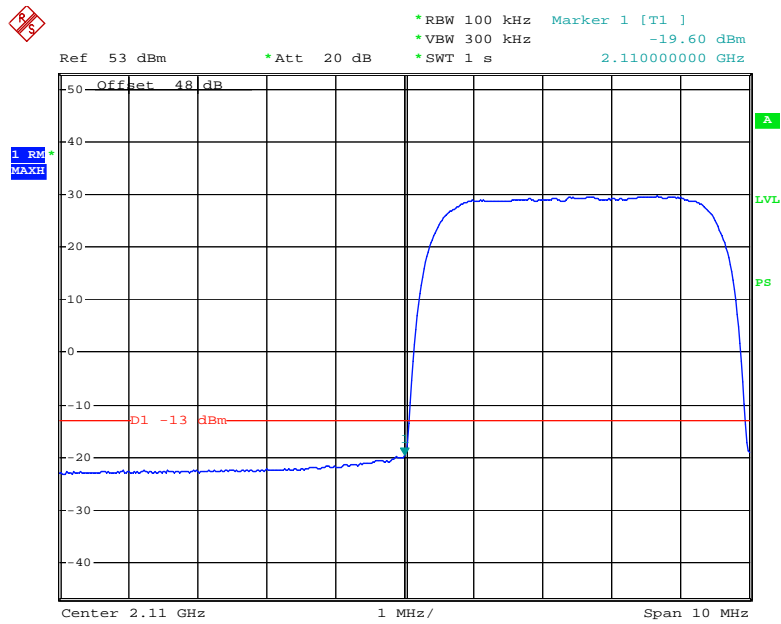

Date: 8.JAN.2010 09:02:51

Downlink mode (One carrier), Highest Channel

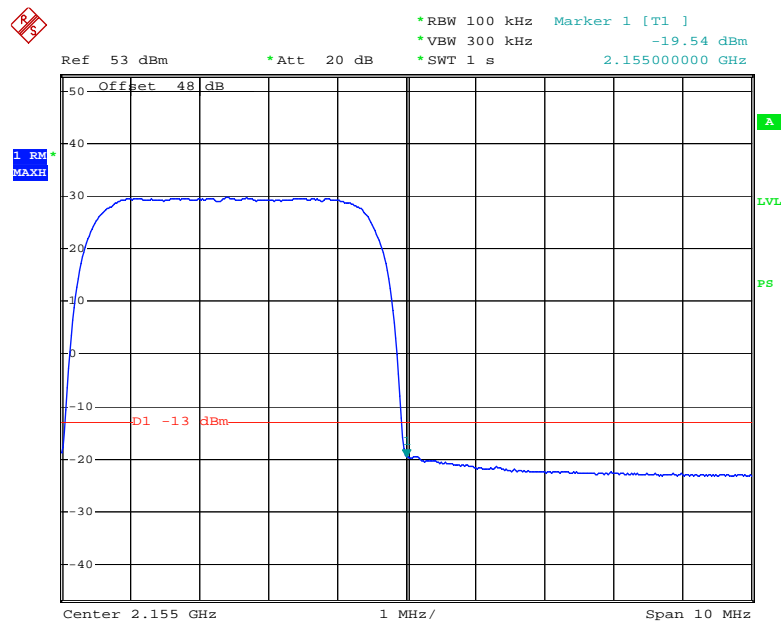

Date: 8.JAN.2010 09:01:22

Downlink mode (Two carriers), Lowest Channel

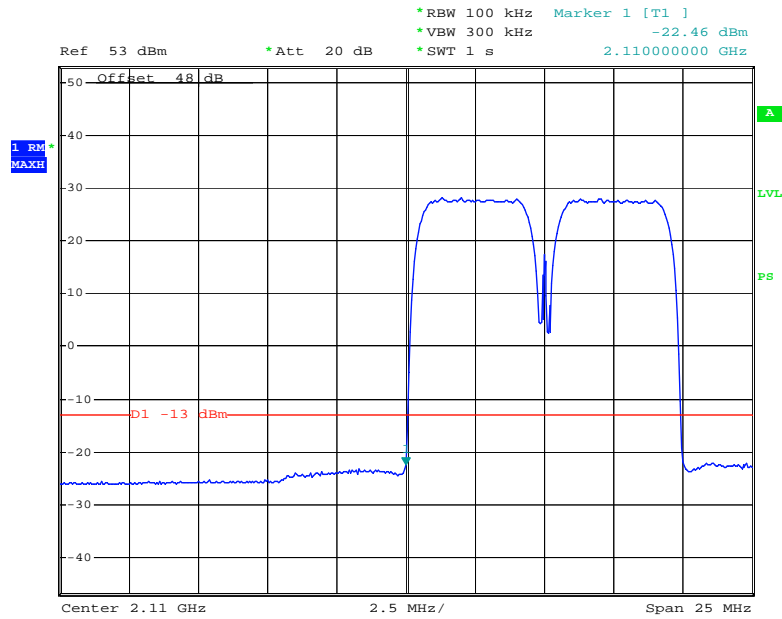

Date: 28.APR.2010 11:18:51

Downlink mode (Two carriers), Highest Channel

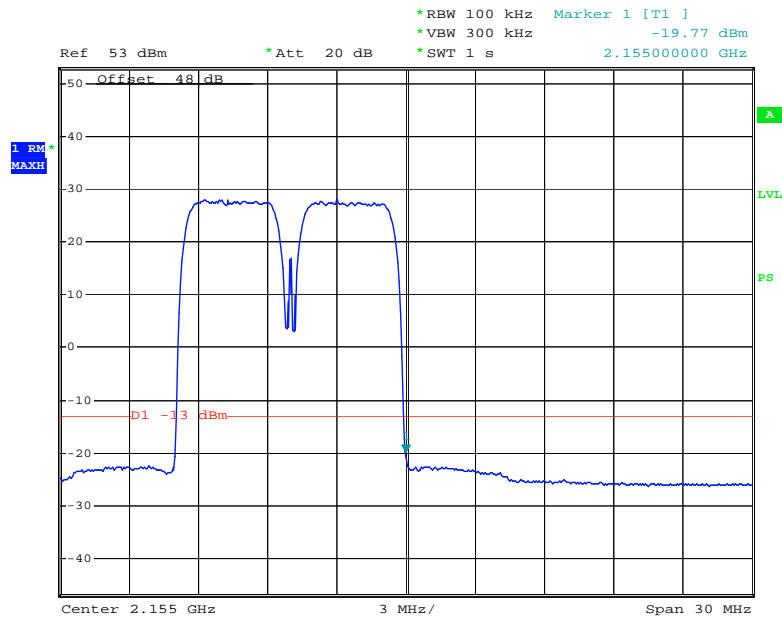

Date: 28.APR.2010 11:24:49

Downlink mode (Three carriers), Lowest Channel

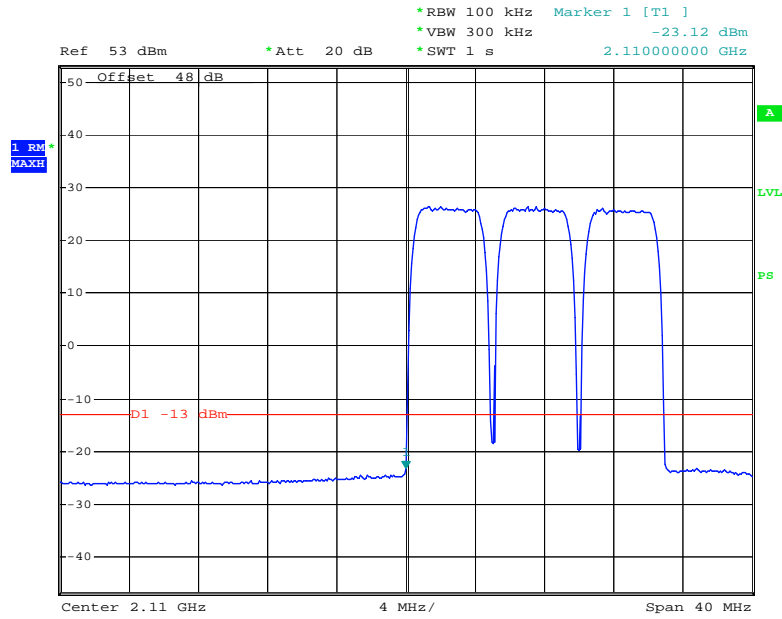

Date: 28.APR.2010 11:05:43

Downlink mode (Three carriers), Highest Channel

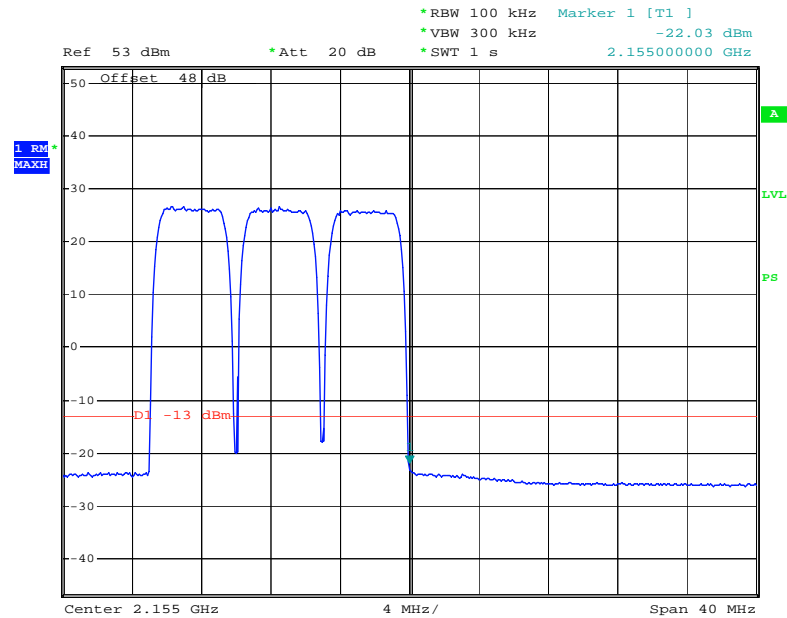

Date: 28.APR.2010 11:12:04

Downlink mode (Four carriers), Lowest Channel

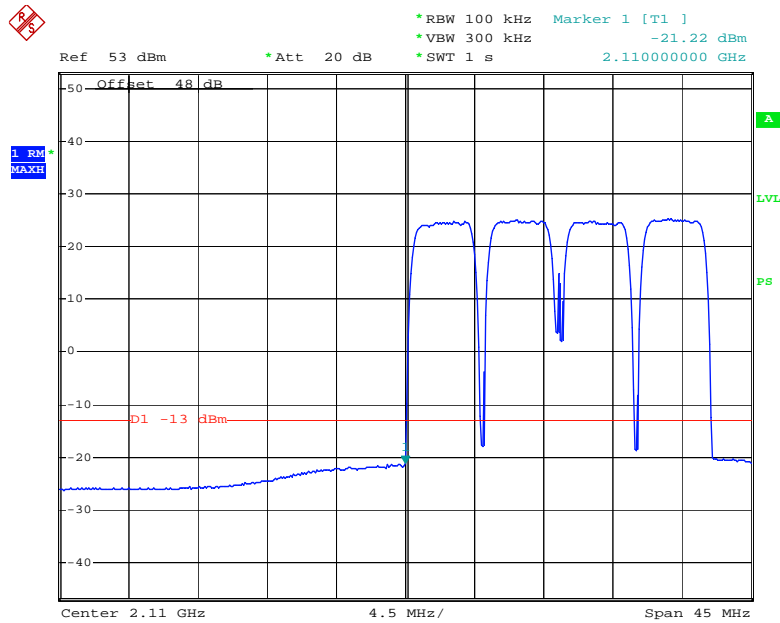

Date: 8.JAN.2010 09:36:06

Downlink mode (Four carriers), Highest Channel

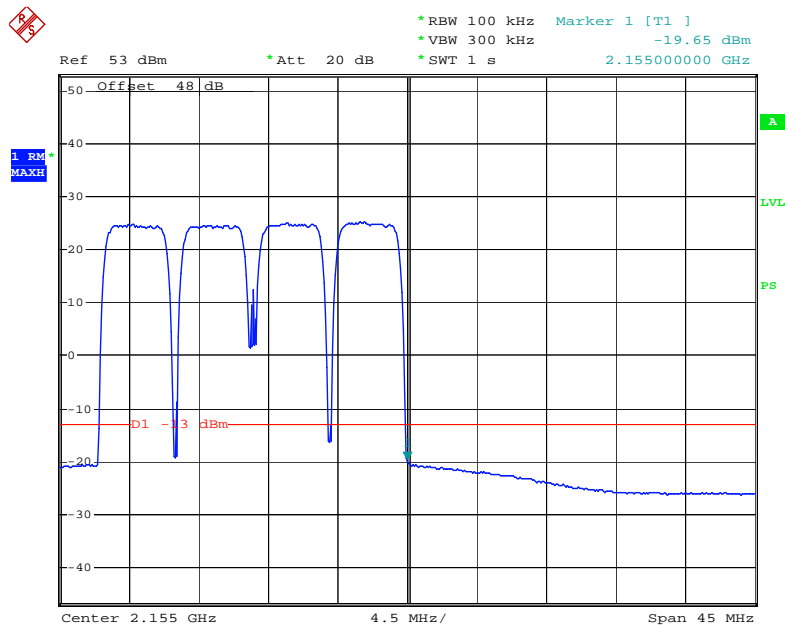

Date: 8.JAN.2010 09:33:35

FCC §2.1055 & §27.54 - FREQUENCY STABILITY

Applicable Standard

FCC §2.1055 (a), §2.1055 (d), §27.54

According to §27.54, the frequency stability shall be sufficient to ensure that the fundamental emissions stay within the authorized bands of operation.

Test Procedure

Frequency Stability vs. Temperature: The equipment under test was connected to an external DC power supply and the RF output was connected to communication test set via feed-through attenuators. The EUT was placed inside the temperature chamber. The DC leads and RF output cable exited the chamber through an opening made for the purpose.

After the temperature stabilized for approximately 20 minutes, the frequency output was recorded from the communication test set.

Frequency Stability vs. Voltage: An external variable DC power supply was connected to the battery terminals of the equipment under test. The voltage was set to 115% of the nominal value and was then decreased until the transmitter light no longer illuminated; i.e., the battery end point. The output frequency was recorded for each battery voltage.

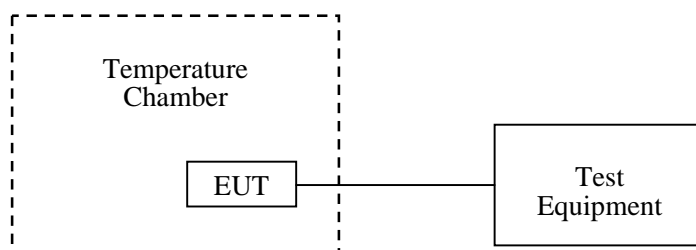

Test Equipment List and Details

Manufacturer	Description	Model	Serial Number	Calibration Date	Calibration Due Date
WUHUAN	Temperature & Humidity Chamber	HTP205	20021115	2009-05-09	2010-05-09
Rohde & Schwarz	Universal Radio Communication Tester	CMU200	109038	2009-05-09	2010-05-09

* **Statement of Traceability:** Bay Area Compliance Laboratories Corp. (Shenzhen) attests that all calibrations have been performed in accordance to NVLAP requirements, traceable to the NIST.

Test Data**Environmental Conditions**

Temperature:	25 °C
Relative Humidity:	56 %
ATM Pressure:	100.0kPa

The testing was performed by Weir Zhong on 2009-12-23.

Middle Channel, $f_0 = 2132.5$ MHz				
Temperature (°C)	Power Supplied (Vac) RU Unit	Frequency Error (Hz)	Frequency Error (ppm)	Test Result
-30	102	18	0.008441	Compliant
	120	20	0.009379	Compliant
	138	15	0.007034	Compliant
-20	102	17	0.007972	Compliant
	120	12	0.005627	Compliant
	138	20	0.009379	Compliant
-10	102	13	0.006096	Compliant
	120	19	0.00891	Compliant
	138	10	0.004689	Compliant
0	102	16	0.007503	Compliant
	120	17	0.007972	Compliant
	138	9	0.00422	Compliant
10	102	10	0.004689	Compliant
	120	13	0.006096	Compliant
	138	15	0.007034	Compliant
20	102	10	0.004689	Compliant
	120	17	0.007972	Compliant
	138	21	0.009848	Compliant
30	102	16	0.007503	Compliant
	120	20	0.009379	Compliant
	138	15	0.007034	Compliant
40	102	23	0.010785	Compliant
	120	17	0.007972	Compliant
	138	24	0.011254	Compliant
50	102	20	0.009379	Compliant
	120	21	0.009848	Compliant
	138	18	0.008441	Compliant

******* END OF REPORT *******