

## ELECTROMAGNETIC EMISSIONS COMPLIANCE REPORT INTENTIONAL RADIATOR CERTIFICATION

**Product Name** : RF power amplifier  
**Model Number** : LPA1900-160-SC01  
**Trade Name** : BTI  
**FCC ID** : WBK1900-160  
**Report Number** : SZEE090616264315  
**Date** : Jun. 25, 2009

Standards	Results
<input checked="" type="checkbox"/> FCC Part 15	PASS
<input checked="" type="checkbox"/> FCC Part 24	PASS

Prepared for:

**Bravo Tech (Shenzhen) Co., Ltd**  
**No.8 Building, The 3<sup>rd</sup> Zone, Tangtou Industrial Park,**  
**Shiyan, Baoan District, Shenzhen City**  
**TEL: 86-755-29512233**  
**FAX: 86-755-29512299**

Prepared by:

**CENTRE TESTING INTERNATIONAL CORPORATION**  
**Building C, Hongwei Industrial Zone, Baoan 70 District,**  
**Shenzhen, Guangdong, China**  
**TEL: +86-755-3368 3668**  
**FAX: +86-755-3368 3385**

**This report shall not be reproduced, except in full, without the written approval of  
CENTRE TESTING INTERNATIONAL CORPORATION**

## TABLE OF CONTENTS

Description	Page
<b>1. CERTIFICATION INFORMATION .....</b>	<b>4</b>
<b>2. TEST SUMMARY .....</b>	<b>5</b>
<b>3. MEASUREMENT UNCERTAINTY .....</b>	<b>5</b>
<b>4. PRODUCT INFORMATION .....</b>	<b>6</b>
<b>5. TEST &amp; SUPPORT EQUIPMENT .....</b>	<b>7</b>
5.1. TEST EQUIPMENT .....	7
5.2. SUPPORT EQUIPMENT.....	7
<b>6. 26DB OCCUPIED BANDWIDTH.....</b>	<b>8</b>
6.1. BLOCK DIAGRAM OF TEST SETUP .....	8
6.2. TEST PROCEDURE.....	8
6.3. TEST RESULT .....	8
6.4. GRAPH.....	8
<b>7. RF POWER OUTPUT.....</b>	<b>10</b>
7.1. REQUIREMENTS.....	10
7.2. BLOCK DIAGRAM OF TEST SETUP .....	10
7.3. TEST PROCEDURE.....	10
7.4. TEST RESULTS .....	10
7.5. GRAPH.....	10
<b>8. FREQUENCY STABILITY .....</b>	<b>13</b>
8.1. LIMITS.....	13
8.2. BLOCK DIAGRAM OF TEST SETUP .....	13
8.3. TEST PROCEDURE.....	13
8.4. TEST RESULT .....	13
<b>9. CONDUCTED SPURIOUS EMISSIONS MEASUREMENT .....</b>	<b>14</b>
9.1. REQUIRMENTS .....	14
9.2. BLOCK DIAGRAM OF TEST SETUP .....	15
9.3. TEST PROCEDURE.....	15
9.4. TEST RESULT .....	15

<b>10. RADIATED EMISSIONS MEASUREMENT .....</b>	<b>20</b>
10.1. LIMITS .....	20
10.2. BLOCK DIAGRAM OF TEST SETUP .....	21
10.3. TEST PROCEDURE .....	22
10.4. TEST RESULT .....	23
10.4.1. RESULTS OF RADIATED EMISSIONS (9KHZ~150KHZ) .....	23
10.4.2. RESULTS OF RADIATED EMISSIONS (150KHZ~30MHZ) .....	24
10.4.3. RESULTS OF RADIATED EMISSIONS (30MHZ~1GHZ) .....	25
10.4.4. RESULTS FOR RADIATED EMISSIONS (ABOVE 1GHZ) .....	28
<b>11. RADIATED SPURIOUS EMISSIONS MEASUREMENT .....</b>	<b>35</b>
11.1. LIMITS .....	35
11.2. BLOCK DIAGRAM OF TEST SETUP .....	35
11.3. TEST PROCEDURE .....	35
11.4. TEST RESULT .....	35
11.5. GRAPH .....	35
<b>APPENDIX 1 PHOTOGRAPHS OF TEST SETUP .....</b>	<b>36</b>
<b>APPENDIX 2 EXTERNAL PHOTOGRAPHS OF EUT .....</b>	<b>39</b>
<b>APPENDIX 3 INTERNAL PHOTOGRAPHS OF EUT .....</b>	<b>41</b>

*N/A means not applicable.*

## 1. CERTIFICATION INFORMATION

**Applicant & Address:** Bravo Tech (Shenzhen) Co., Ltd  
No.8 Building, The 3rd Zone, Tangtou Industrial Park,  
Shiyan, BaoanDistrict, Shenzhen City  
Bravo Tech (Shenzhen) Co., Ltd

**Manufacturer & Address:** No.8 Building, The 3rd Zone, Tangtou Industrial Park,  
Shiyan, BaoanDistrict, Shenzhen City

**Type of Test:** FCC Part 15 & 24 (Certification)

**FCC ID:** WBK1900-160

**Equipment Under Test:** RF power amplifier

**Test Model:** LPA1900-160-SC01

**Trade Name:** BTI

**Serial Number:** N/A

**Date of test:** Jun. 16, 2009 to Jun. 27, 2009

**Condition of Test Sample:** Normal

The above equipment was tested by Centre Testing International for compliance with the requirements set forth in the FCC Rules and Regulations Part 15, Subpart B & Part 24, Subpart E and the measurement procedure according to ANSI C63.4.  
The test results of this report relate only to the tested sample identified in this report.

Prepared by :

  
\_\_\_\_\_  
Lily Yan

Inspected by :

  
\_\_\_\_\_  
Christy Chen

Approved by:

  
\_\_\_\_\_  
Jim Zhang  
Manager



Date

:

\_\_\_\_\_  
Jun. 30, 2009

## 2. TEST SUMMARY

Clause	Test Item	Rule	Result
6	26dB Occupied Bandwidth	24.238(b)	<b>PASS</b>
7	RF POWER OUTPUT	24.232(a)/2.1046	<b>PASS</b>
8	Frequency Stability	24.235	<b>Not applicable</b>
9	Conducted Spurious Emissions	24.238/2.1051/2.1057	<b>PASS</b>
10	Radiated Emissions	24.238/15.209	<b>PASS</b>
11	Radiated Spurious Emissions	24.238/15.209	<b>PASS</b>

**TABLE FOR TEST MODES**

<b>Power Supply:</b>	DC 30V	<b>Mode:</b>	Maximum Output Power
<b>Temperature:</b>	24°C	<b>Humidity:</b>	63%
<b>Input Signal:</b>	4CDMA_8.0	<b>RF Output Power:</b>	160W (52dBm)
Test Item	Operation Band		
26dB Occupied Bandwidth	Low/Mid/High		
RF POWER OUTPUT	Low/Mid/High		
Conducted Spurious Emissions	Low/High		
Radiated Emissions	Low/Mid/High		
Radiated Spurious Emissions	Low/High		

## 3. MEASUREMENT UNCERTAINTY

This uncertainty represents an expanded uncertainty expressed at approximately the 95% confidence level using a coverage factor of  $k=2$ .

Measurement items	Uncertainty
Maximum Peak Output Power/ Conducted Spurious Emissions	0.5 dB
Occupied Bandwidth	--
Radiated Emissions / Band Edge	3.4 dB

#### 4. PRODUCT INFORMATION

Electrical Specifications			
Parameter		Description	
Frequency		1930 ~ 1990MHz	
Output power		160Watts average max. ( CDMA2000, PAR: 8.0dB)	
Spurious Emissions		-45dBc@ $\Delta f=885-1.25\text{MHz}$ , 30kHz RBW -55dBc@ $\Delta f=1.25-1.98\text{MHz}$ , 30kHz RBW -55dBc@ $\Delta f=1.25-2.25\text{MHz}$ , 30kHz RBW -13dBm@ $\Delta f=2.25-4\text{MHz}$ , 30kHz RBW	
RF Gain		57.0 $\pm$ 1.0 dB @ frequency range, DC 30V, room temp.	
Normal Operating Voltage		DC 30V $\pm$ 1.0V	
Operating Voltage		DC 29 ~ 31V	
RF Gain Variation over Voltage & Temp.		$\pm$ 1.0dB @ $29 \leq V_{\text{sup}} \leq 31\text{V}$ , -30 ~ 55 °C	
Gain Flatness		Peak to Peak 0.2dB over any 5MHz	
Input/Output Return Loss		-18dB min.	
Output Protection		Mismatch protected with isolator	
Efficiency		$\geq 15\%$ @30V, $P_o=50.8\text{dBm}$	
Operating Temperature		-30°C to +55°C (Air Temperature inside System),	
Input Power ALC		Operating point	Output power:52.0dBm $\pm$ 0.5dB
		Operating range	6dB min
		Over Pwr	Output Pwr:52dBm $\pm$ 0.5dB
Alarm and Functions Specifications			
Parameter		Description	
Over temperature alarm		Alarm and shutdown at 95°C base temperature, auto-recover at 90°C base temperature	
Over power alarm		Alarm and shutdown when output power is over 52.3dBm, no auto-recover.	
ALC		ALC level:	52.0 $\pm$ 0.5dBm
		ALC range:	$\geq 6\text{dB}$
VSWR alarm		Alarm and shutdown when reject is over 5, auto-recover at 3	
Description of the connectors – RF Part			
Port Name		Type	Warning
Input		SMA Female (50 $\Omega$ )	Normal :-6.2dBm max input power +1dBm
Output		N Female (50 $\Omega$ )	Normal :50.8dBm max output power 52.0dBm
Description of the connectors – RF Part			
Port Name	Type	NO	Warning
DC IN	D-Sub type DSCD175PS1M (Male)	A1、A2	VDC type +30V, range 24~32V
		A3、A4	GND to VDC

## 5. TEST & SUPPORT EQUIPMENT

### 5.1. Test equipment

Equipment	Manufacturer	Model Number	Serial Number	Due Date
Receiver	R&S	ESCI	100435	01/29/2010
Spectrum Analyzer	Agilent	E4443A	MY45300910	09/07/2009
Biconilog Antenna	A.H.System	SAS-521-2	487	06/05/2010
Horn Antenna	ETS-LINGREN	3117	00057407	06/27/2010
Loop Antenna	ETS-LINGREN	6502	00071730	09/22/2010
3M Chamber & Accessories	ETS-LINGREN	FACT-3	N/A	05/11/2010
Multi device Controller	ETS-LINGREN	2090	00057230	--
Microwave Preamplifier	Agilent	8449B	3008A02425	--

### 5.2. Support equipment

Equipment	Manufacturer	Model Number	Serial Number
Signal Generator	AEROFLEX	IFR 3416	341005/038
Power Meter	Agilent	E4418B	8412991000
Attenuator	上海华湘计算机通讯工程有限公司	DC-4GHz/30dB/250W	07101270
Directional Coupler	WAVECOM	L-910-30	163
Attenuator	上海华湘计算机通讯工程有限公司	DC-4GHz/20dB/5W	06082320
Power supply	LAMBDA	GEN30-50	GEN30-50-IEEE-D
DC power source	香港龙威	TPR-6420D	0371643





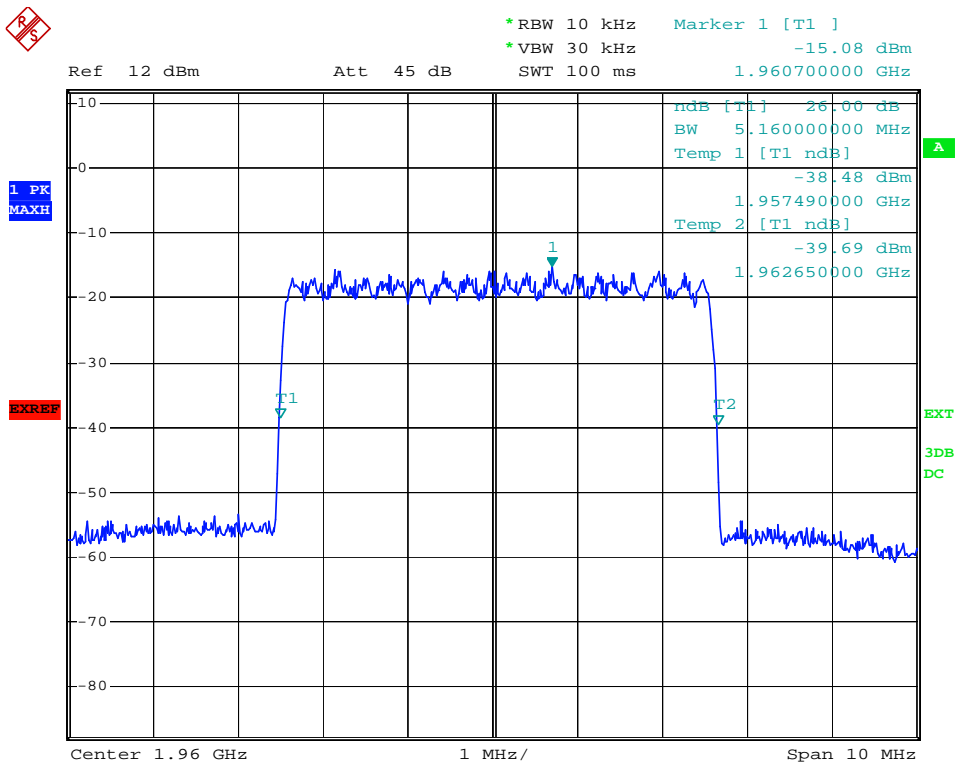

Mid Band – 1960.0MHz

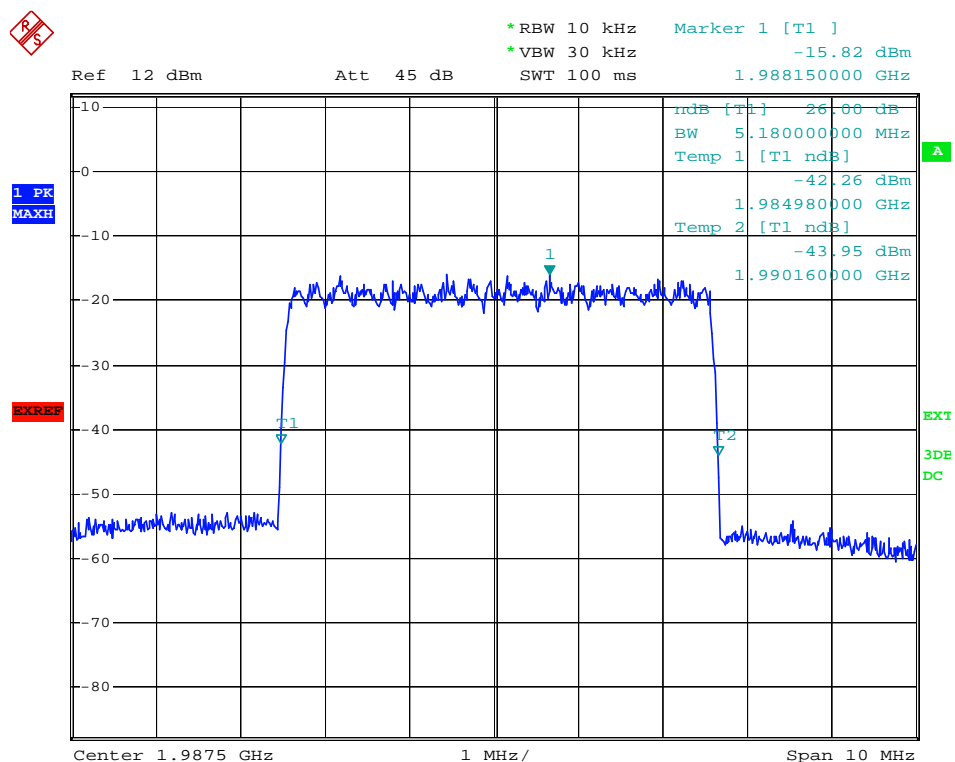

High Band – 1987.5MHz

## 7. RF POWER OUTPUT

### 7.1. REQUIREMENTS

**Rule: 2.1046(a)**

For transmitters other than single sideband, independent sideband and controlled carrier radiotelephone, power output shall be measured at the RF output terminals when the transmitter is adjusted in accordance with the tune-up procedure to give the values of current and voltage on the circuit elements specified in Sec. 2.1033(c)(8). The electrical characteristics of the radio frequency load attached to the output terminals when this test is made shall be stated.

**Rule: 24.232**

Not applicable.

This device contains no antenna, thus HAAT is not applicable, and no limits should be used.

### 7.2. BLOCK DIAGRAM OF TEST SETUP

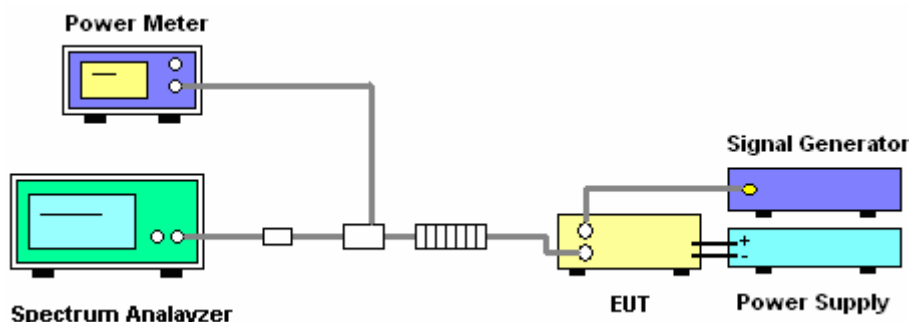

### 7.3. TEST PROCEDURE

1. The transmitter output (antenna port) was connected to the spectrum analyzer.
2. Set spectrum analyzer's RBW and VBW to applicable value with Peak in Max Hold.
3. Record the channel power within 1MHz bandwidth between CF.

### 7.4. TEST RESULTS

Operation Band	Center Frequency (MHz)	Measured Power (dBm)
Low	1932.5	51.51
Mid	1960.0	50.86
How	1987.5	51.10

### 7.5. GRAPH

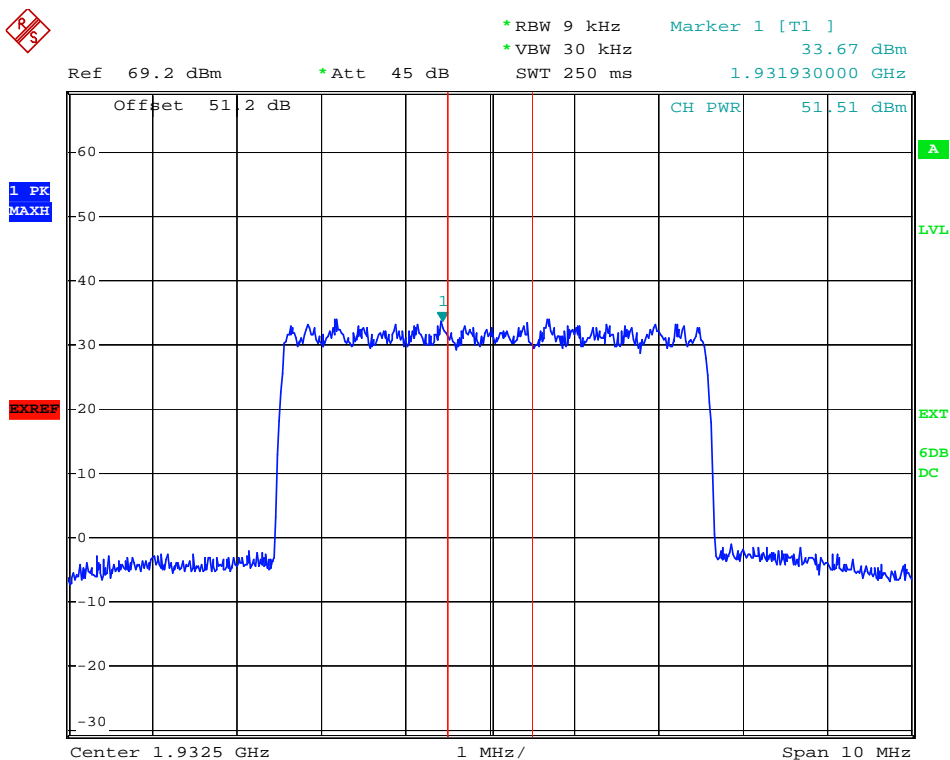

Low Band-1932.5MHz

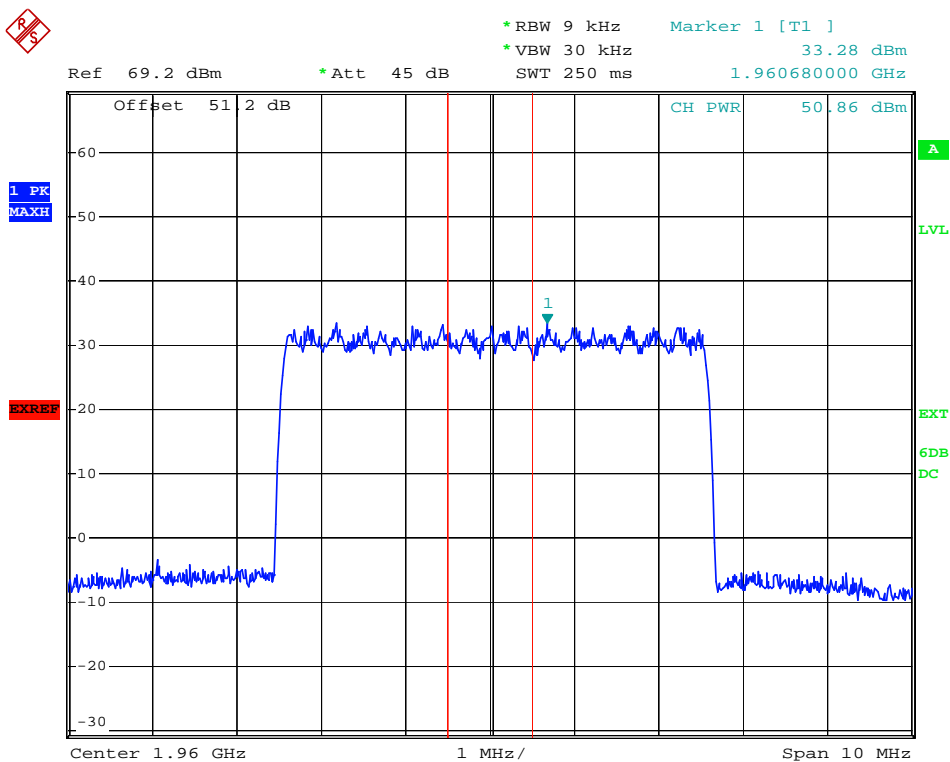

Mid Band - 1960.0MHz

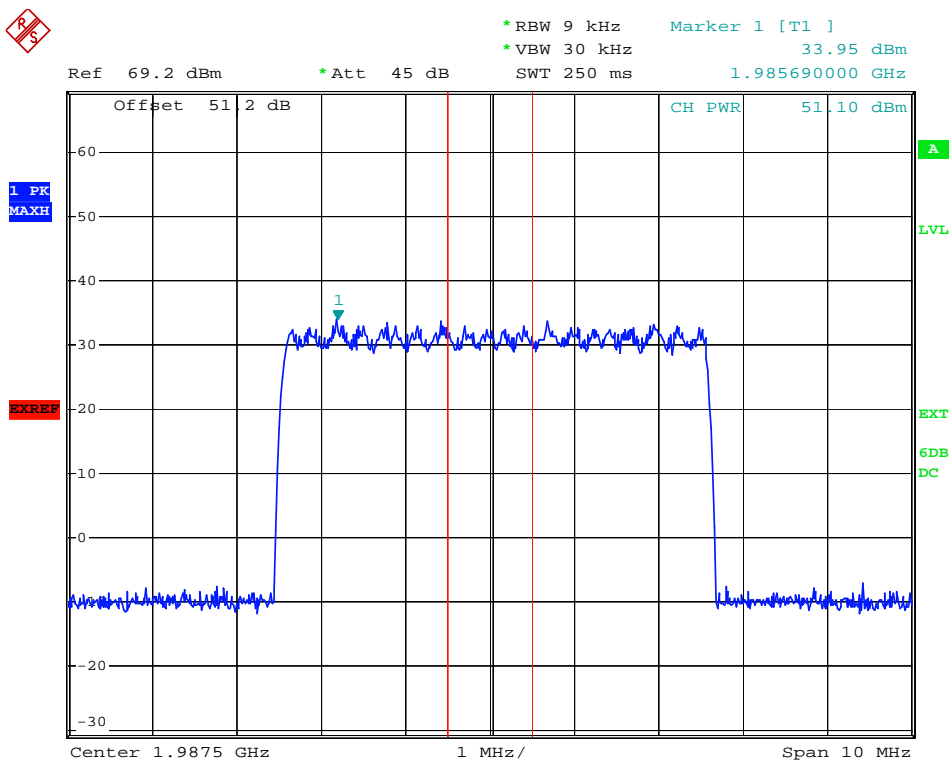

High Band – 1.9875MHz

## **8. FREQUENCY STABILITY**

### **8.1. LIMITS**

#### **Rule: 24.235:**

The frequency stability shall be sufficient to ensure that the fundamental emission stays within the authorized frequency block.

### **8.2. BLOCK DIAGRAM OF TEST SETUP**

None

### **8.3. TEST PROCEDURE**

None

### **8.4. TEST RESULT**

Not applicable.

This device uses common oscillator(s) and amplifier(s) to down-convert and up-convert the modulated RF carrier so that the output frequency tracks the input frequency.

## 9. CONDUCTED SPURIOUS EMISSIONS MEASUREMENT

### 9.1. REQUIRMENTS

#### Rule: 2.1051

The radio frequency voltage or powers generated within the equipment and appearing on a spurious frequency shall be checked at the equipment output terminals when properly loaded with a suitable artificial antenna. Curves or equivalent data shall show the magnitude of each harmonic and other spurious emission that can be detected when the equipment is operated under the conditions specified in Sec. 2.1049 as appropriate.

The magnitude of spurious emissions which are attenuated more than 20 dB below the permissible value need not be specified.

#### Rule: 2.1057

(a) In all of the measurements set forth in Sec. 2.1051, the spectrum shall be investigated from the lowest radio frequency signal generated in the equipment, without going below 9 kHz, up to at least the tenth harmonic of the highest fundamental frequency or to 40 GHz, whichever is lower.

(b) Particular attention should be paid to harmonics and sub-harmonics of the carrier frequency as well as to those frequencies removed from the carrier by multiples of the oscillator frequency. Radiation at the frequencies of multiplier stages should also be checked.

(c) The amplitude of spurious emissions which are attenuated more than 20 dB below the permissible value need not be reported.

#### Rule: 24.238

(a) On any frequency outside a licensee's frequency block, the power of any emission shall be attenuated below the transmitter power (P) by at least  $43 + 10 \log (P)$  dB.

(b) Compliance with these provisions is based on the use of measurement instrumentation employing a resolution bandwidth of 1 MHz or greater. However, in the 1 MHz bands immediately outside and adjacent to the frequency block a resolution bandwidth of at least one percent of the emission bandwidth of the fundamental emission of the transmitter may be employed. The emission bandwidth is defined as the width of the signal between two points, one below the carrier center frequency and one above the carrier center frequency, outside of which all emissions are attenuated at least 26 dB below the transmitter power.

(c) When measuring the emission limits, the nominal carrier frequency shall be adjusted as close to the licensee's frequency block edges, both upper and lower, as the design permits.

(d) The measurements of emission power can be expressed in peak or average values, provided they are expressed in the same parameters as the transmitter power.

## 9.2. BLOCK DIAGRAM OF TEST SETUP

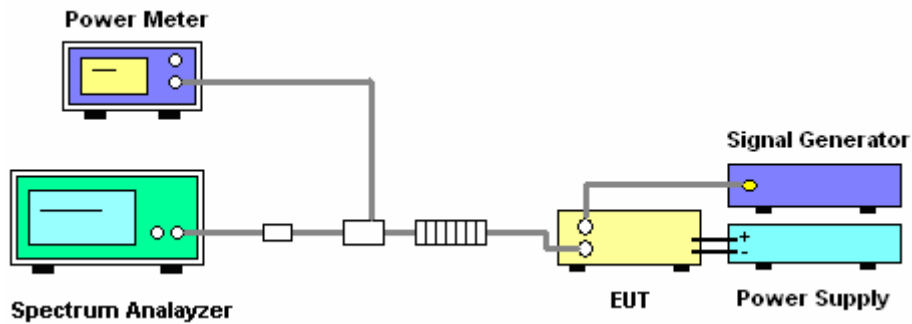

## 9.3. TEST PROCEDURE

1. The transmitter output port was connected to the spectrum analyzer.
  2. Set spectrum analyzer's RBW and VBW to applicable value with Peak in Max Hold.
  3. Make sure EUT work in max output power, and measure the emissions.
- Note: the attenuators' value used below 3GHz is calibrated to 51.23dB, and that above 3GHz is 49.02dB.

## 9.4. Test result

### 9.4.1. Conducted Spurious Emissions – Band Edge

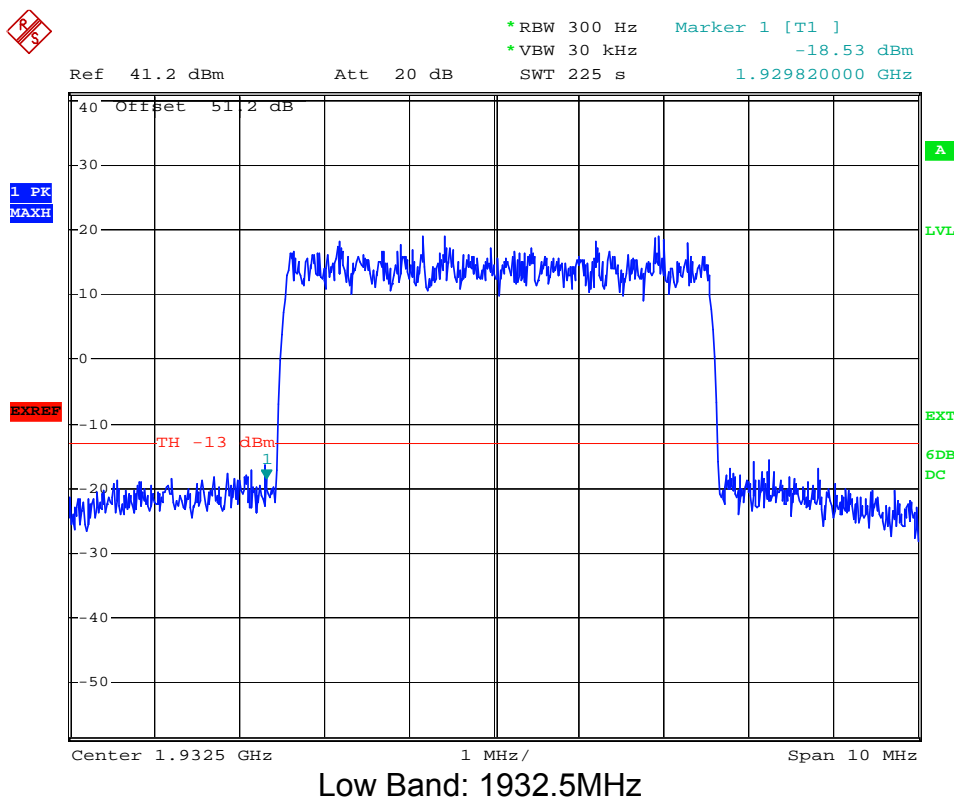

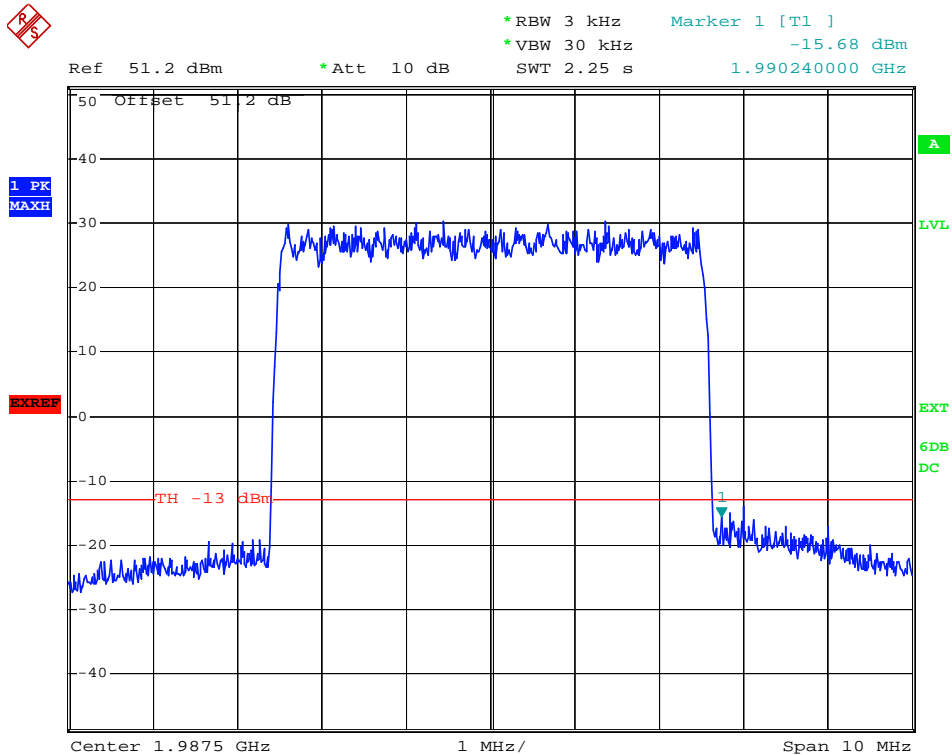

High Band: 1987.5MHz

## 9.4.2. Conducted Spurious Emissions – Below 1GHz

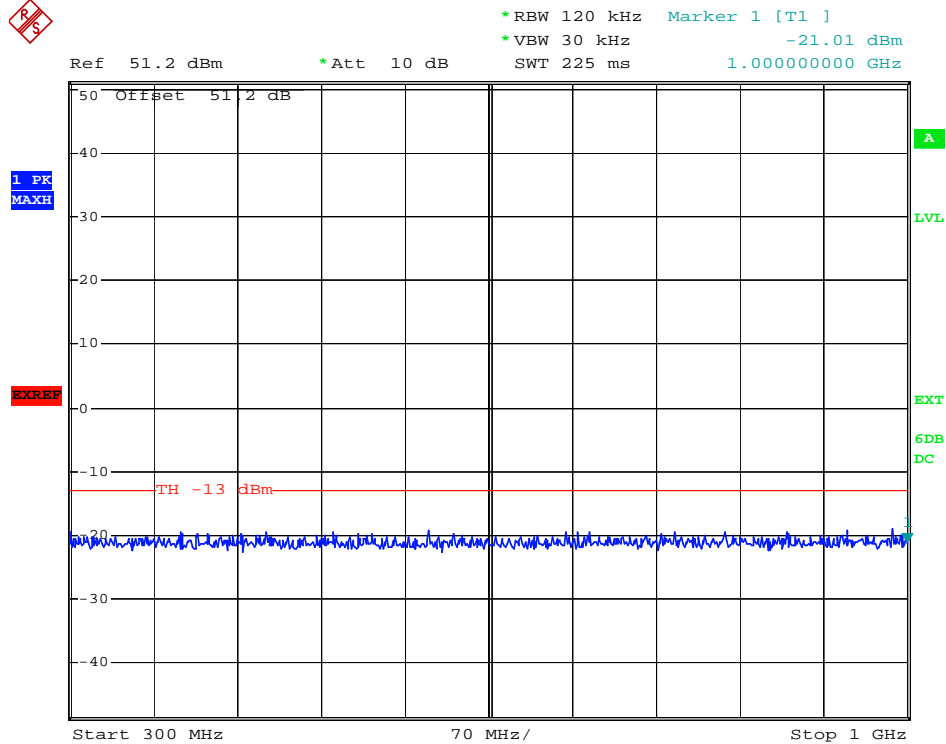



### 9.4.3. Conducted Spurious Emissions – 1GHz~3GHz

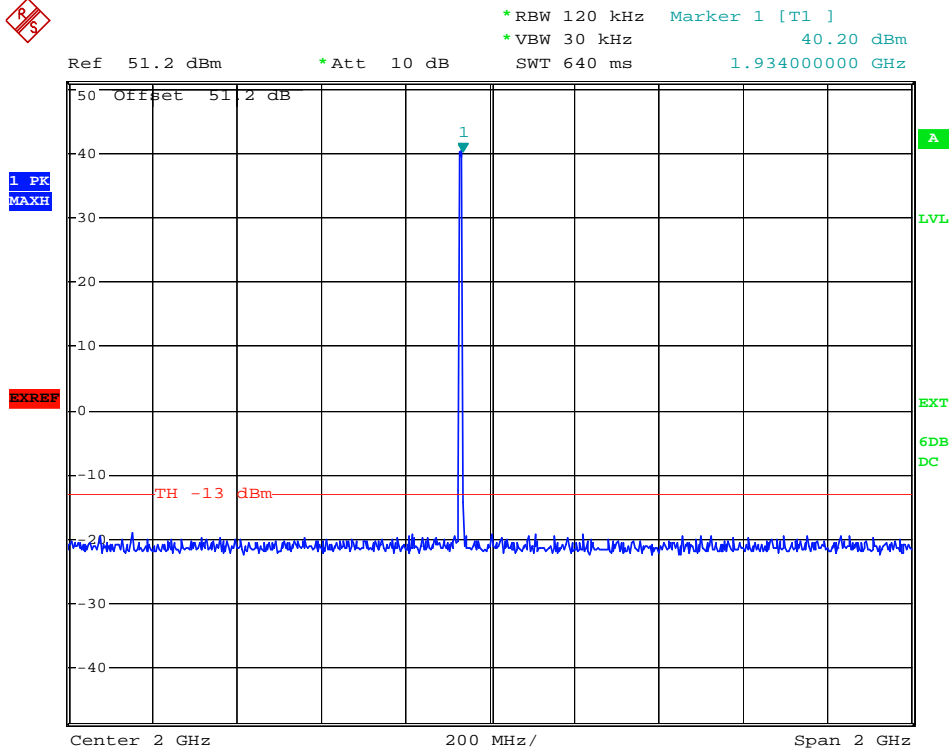

Low Band: 1932.5MHz

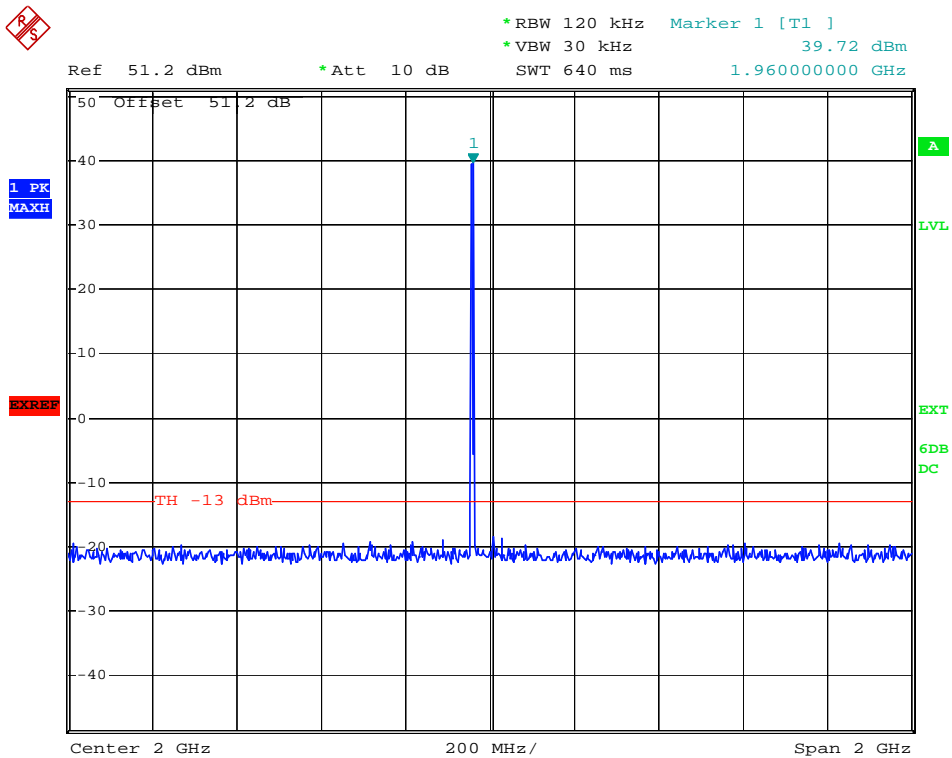

Mid Band: 1960.0MHz

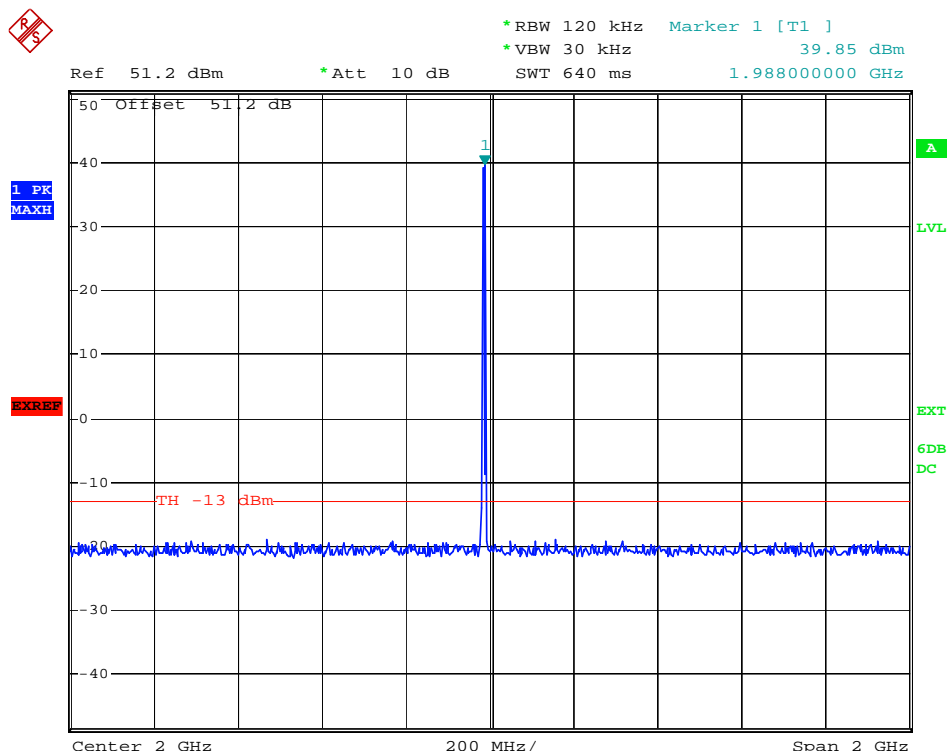

High Band: 1987.5MHz

### 9.4.4. Conducted Spurious Emissions – Above 3GHz

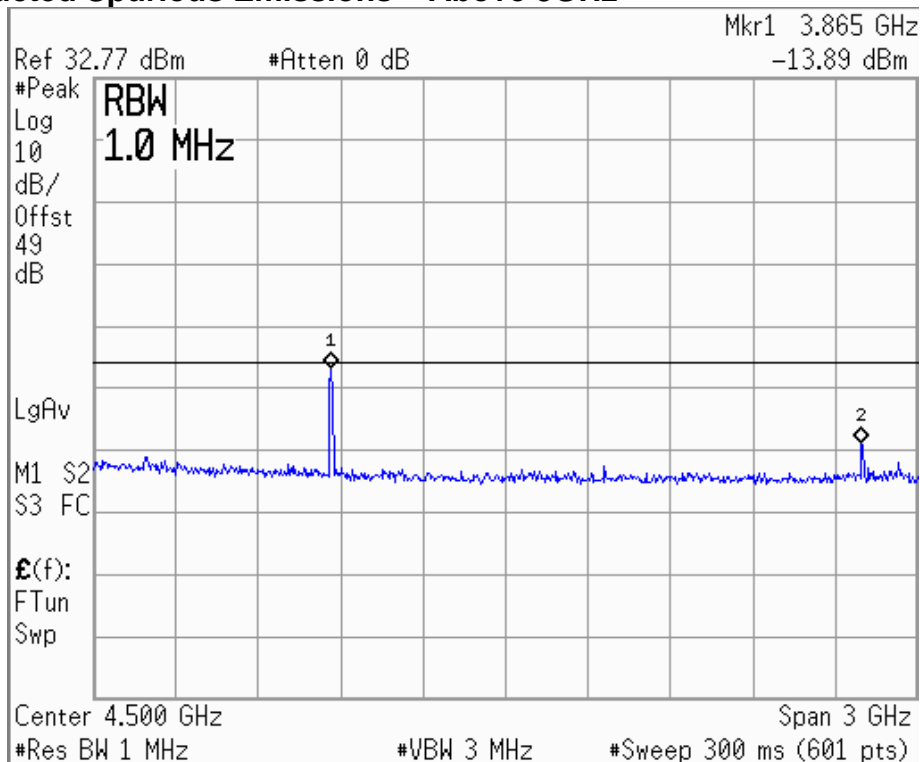

Low Band: 1932.5MHz  
 Measured Average Value @ marker 1: -15.13dBm

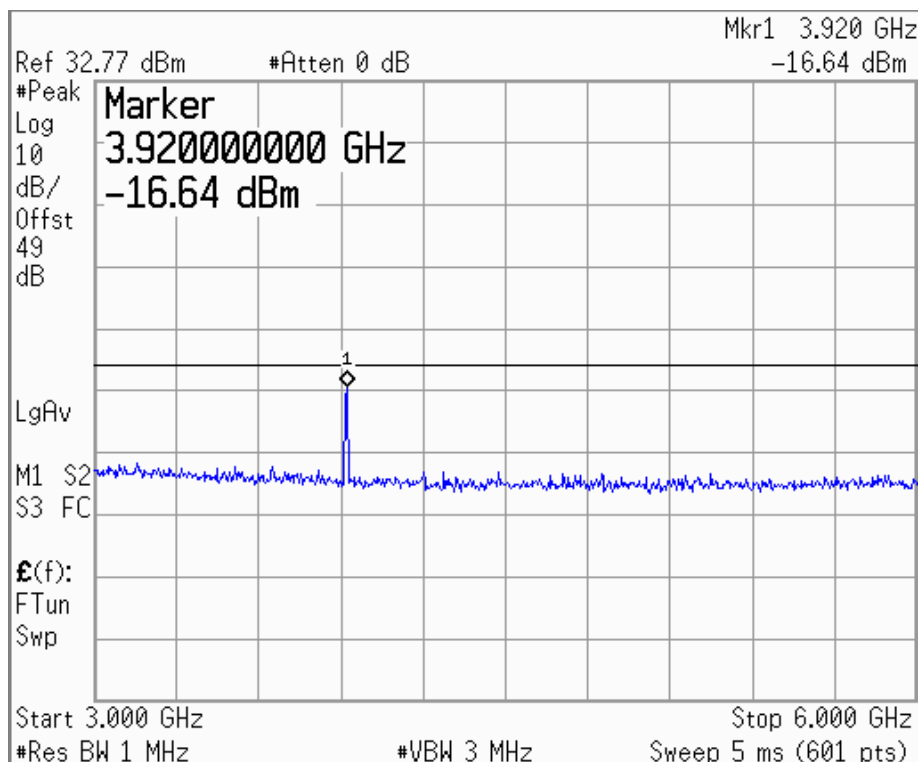

Mid Band: 1960.0MHz  
Measured Average Value @ marker 1: -18.29dBm

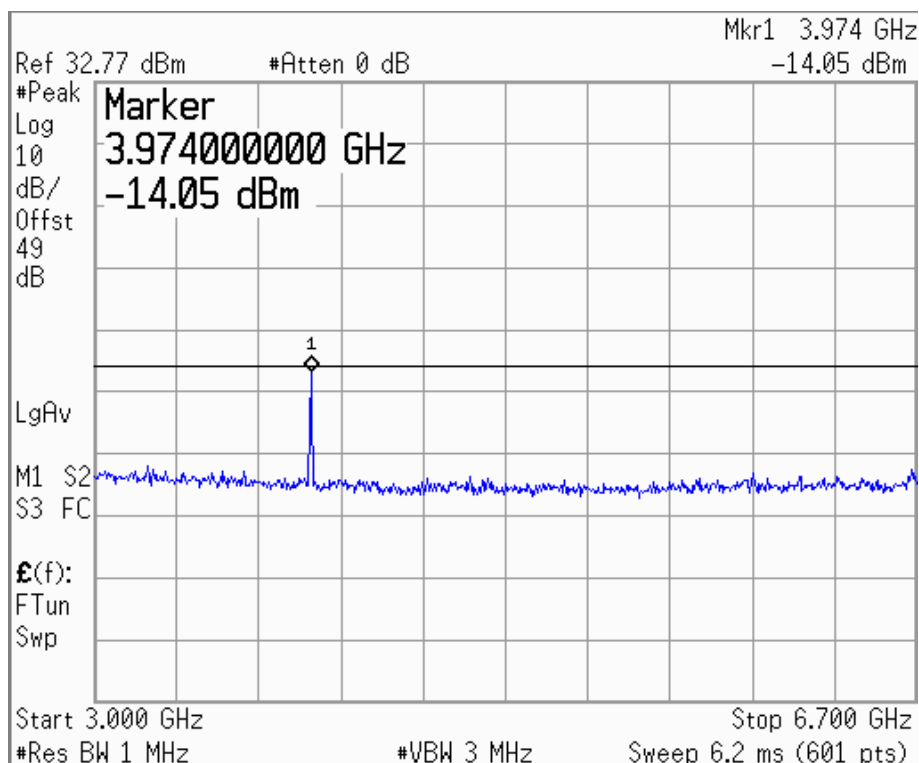

High Band: 1987.5MHz  
Measured Average Value @ marker 1: -16.78dBm

## 10. RADIATED EMISSIONS MEASUREMENT

### 10.1. LIMITS

Rule: FCC Part15.209 -- The field strength of any emissions, which appear outside of operating frequency band and restricted band specified on 15.205(a), shall not exceed the general radiated emission limits as below.

Frequency (MHz)	Field strength ( $\mu\text{V/m}$ )	Distance (m)
0.009-0.490	2400/F(kHz)	300
0.490-1.705	24000/F(kHz)	30
1.705-30	30	30
30-88	100	3
88-216	150	3
216-960	200	3
Above 960	500	3

**Note:**

1. the tighter limit applies at the band edges.
2. this band doesn't include 1930 ~ 1990 MHz

**Limit calculation:**

Limit dB $\mu\text{V/m}$  @1m = Limit dB $\mu\text{V/m}$  @300m+ 90

Limit dB $\mu\text{V/m}$  @1m = Limit dB $\mu\text{V/m}$  @30m + 50

Limit dB $\mu\text{V/m}$  @1m = Limit dB $\mu\text{V/m}$  @3m +10

## 10.2. BLOCK DIAGRAM OF TEST SETUP

For radiated emissions below 30 MHz

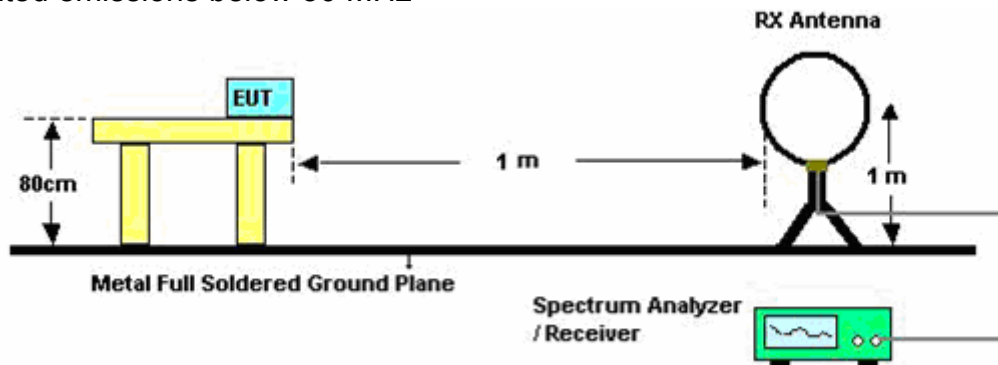

For radiated emissions from 30 – 1000 MHz

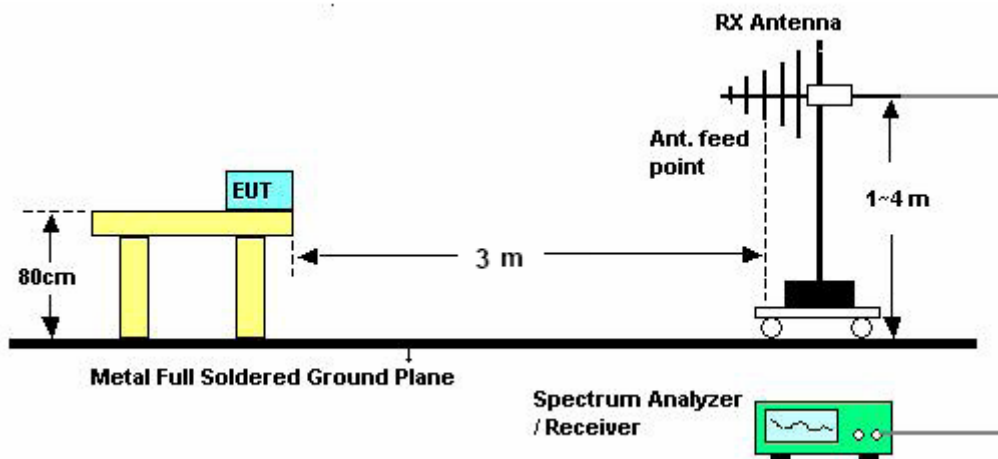

For radiated emissions above 1 GHz

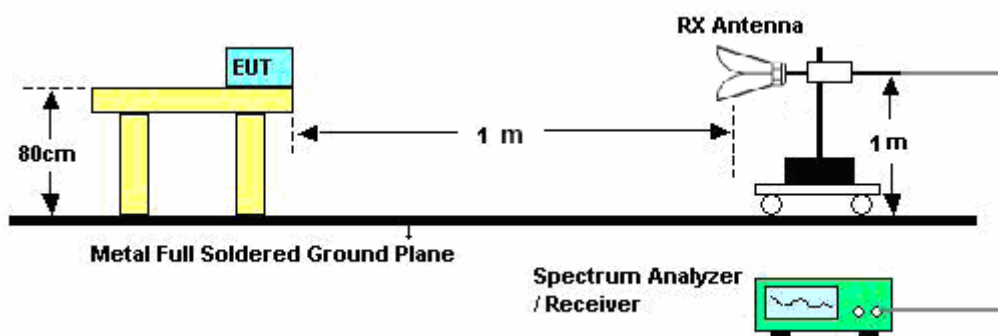

### 10.3. TEST PROCEDURE

1. Configure the EUT: The EUT was placed on the top of the turntable 0.8 meter above ground. The phase center of the receiving antenna mounted on the top of a height-variable antenna tower was placed 3 meters far away from the turntable.
2. Power on the EUT and all the supporting units. The turntable was rotated by 360 degrees to determine the position of the highest radiation.
3. The height of the broadband receiving antenna was varied between one meter and four meters above ground to find the maximum emissions field strength of both horizontal and vertical polarization.
4. For each suspected emissions, the antenna tower was scan (from 1 M to 4 M) and then the turntable was rotated (from 0 degree to 360 degrees) to find the maximum reading.
5. Set the test-receiver system to Peak or CISPR quasi-peak Detect Function with specified bandwidth under Maximum Hold Mode.
6. When the radiated emissions limits are expressed in terms of the average value of the emissions, and pulsed operation is employed, the measurement field strength shall be determined by averaging over one complete pulse train, including blanking intervals, as long as the pulse train does not exceed 0.1 seconds. As an alternative (provided the transmitter operates for longer than 0.1 seconds) or in cases where the pulse train exceeds 0.1 seconds, the measured field strength shall be determined from the average absolute voltage during a 0.1 second interval during which the field strength is at its maximum value.
7. If the emissions level of the EUT in peak mode was lower enough than the average limit specified, then testing will be stopped and peak values of EUT will be reported, otherwise, the emissions will be repeated one by one using the quasi-peak method for below 1GHz.
8. For testing above 1GHz, the emissions level of the EUT in peak mode was lower than average limit (that means the emissions level in peak mode also complies with the limit in average mode), then testing will be stopped and peak values of EUT will be reported, otherwise, the emissions will be measured in average mode again and reported.
9. In case the emission is tested lower than 30MHz, loop antenna has to be used for measurement and the recorded data should be QP measured by receiver. High – Low scan is not required in this case.

### 10.4. TEST RESULT

#### 10.4.1. Results of Radiated Emissions (9kHz~150kHz)

Test Results-H (Measurement Distance: 1m)_Mid Band: 1960MHz					
Frequency (MHz)	Reading Level - peak (dB $\mu$ V/m)	Factor (dB)	Measurement - peak (dB $\mu$ V/m)	Limit - QP (dB $\mu$ V/m)	Result (P/F)
0.0092	59.04	30.34	89.38	138.33	P
0.0475	52.62	14.91	67.53	124.07	P
0.1075	41.79	13.98	55.77	116.98	P

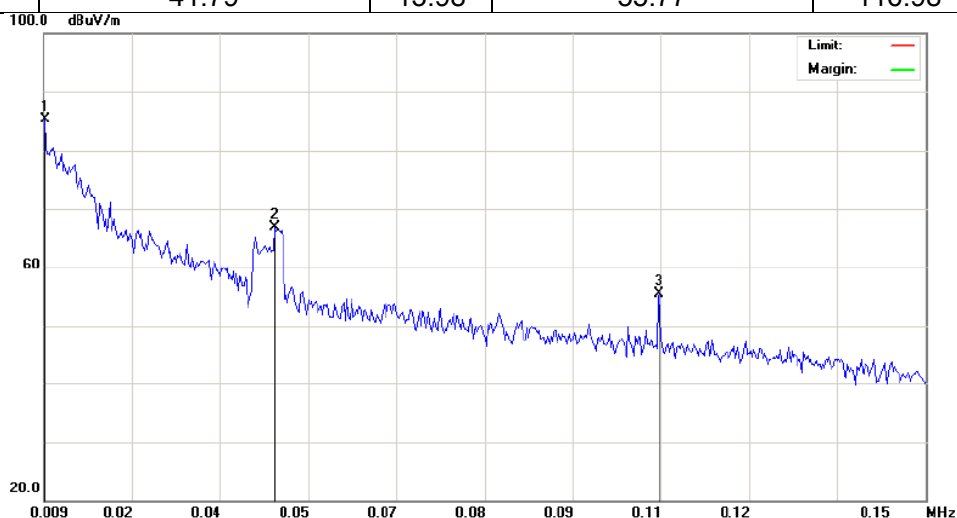

Test Results-V (Measurement Distance: 1m)_Low Band: 1932.5MHz					
Frequency (MHz)	Reading Level - peak (dB $\mu$ V/m)	Factor (dB)	Measurement - peak (dB $\mu$ V/m)	Limit - QP (dB $\mu$ V/m)	Result (P/F)
0.0092	59.04	30.34	89.38	138.33	P
0.0475	52.62	14.91	67.53	124.07	P
0.1075	41.79	13.98	55.77	116.98	P

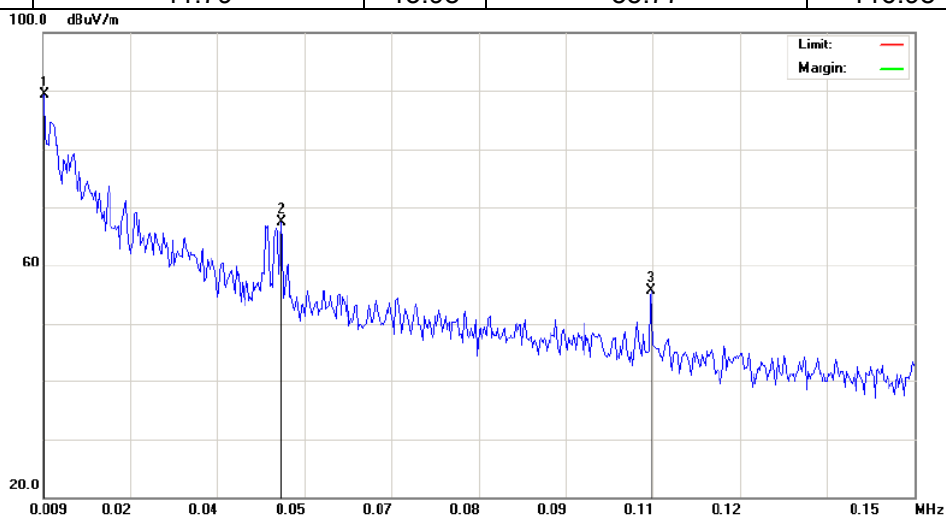

**10.4.2. Results of Radiated Emissions (150kHz~30MHz)**

Test Results-H (Measurement Distance: 1m)_Mid Band: 1960MHz					
Frequency (MHz)	Reading Level - peak (dB $\mu$ V/m)	Factor (dB)	Measurement - peak (dB $\mu$ V/m)	Limit - QP (dB $\mu$ V/m)	Result (P/F)
0.1500	49.54	12.20	61.74	114.08	P
0.5978	40.51	12.06	52.57	82.07	P
1.3938	36.94	12.12	49.06	74.72	P
3.0853	38.68	11.80	50.48	80	P
4.0305	34.75	11.80	46.55	80	P

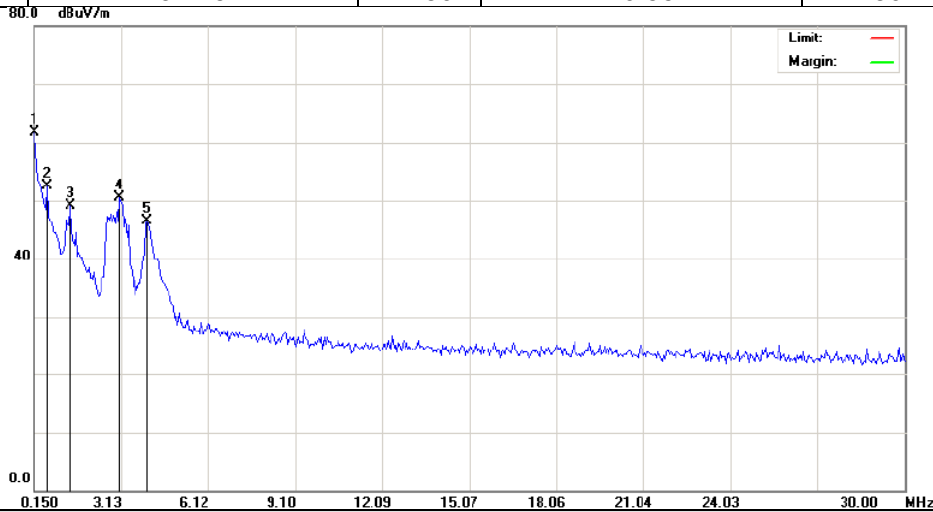

Test Results-V (Measurement Distance: 1m)_Low Band: 1960MHz					
Frequency (MHz)	Reading Level - peak (dB $\mu$ V/m)	Factor (dB)	Measurement - peak (dB $\mu$ V/m)	Limit - QP (dB $\mu$ V/m)	Result (P/F)
0.1500	48.42	12.20	60.62	114.08	P
0.5978	43.54	12.06	55.60	75.10	P
2.7370	29.41	11.85	41.26	80	P
4.2793	33.71	11.77	45.48	80	P

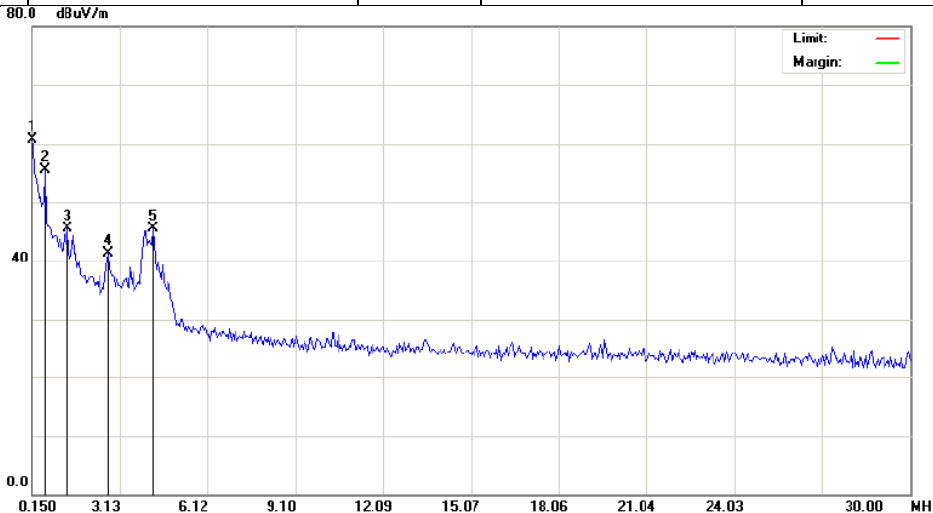



### 10.4.3. Results of Radiated Emissions (30MHz~1GHz)

#### Test Results - H (Measurement Distance: 3m)\_Low Band: 1932.5MHz

No.	Freq. MHz	Reading_Level (dBuV)			Correct Factor dB	Measurement (dBuV/m)			Limit (dBuV/m)		Margin (dB)		P/F
		Peak	QP	AVG		peak	QP	AVG	QP	AVG	QP	AVG	
1	120.5333	22.84	20.58		17.24	40.08	37.82	43.50			-5.68		P
2	359.8000	22.13			17.19	39.32		46.00			-6.68		P
3	479.4333	18.99			20.02	39.01		46.00			-6.99		P

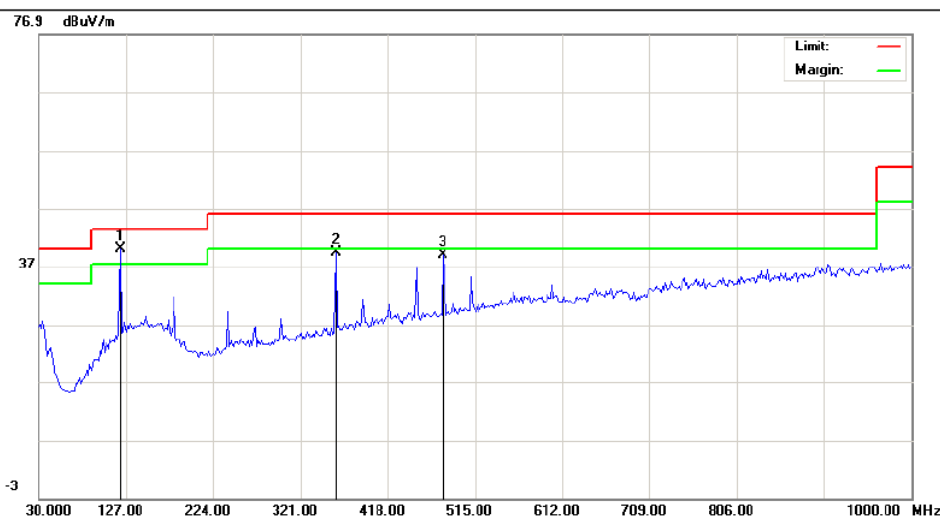

#### Test Results - V (Measurement Distance: 3m)\_Low Band: 1932.5MHz

No.	Freq. MHz	Reading_Level (dBuV)			Correct Factor dB	Measurement (dBuV/m)			Limit (dBuV/m)		Margin (dB)		P/F
		Peak	QP	AVG		peak	QP	AVG	QP	AVG	QP	AVG	
1	120.5333	23.31	22.83		17.24	40.55	40.07	43.50			-3.43		P
2	359.8000	26.31	25.18		17.19	43.50	42.37	46.00			-3.63		P
3	450.3333	18.41			19.60	38.01		46.00			-7.99		P
4	510.1500	15.37			20.88	36.25		46.00			-9.75		P

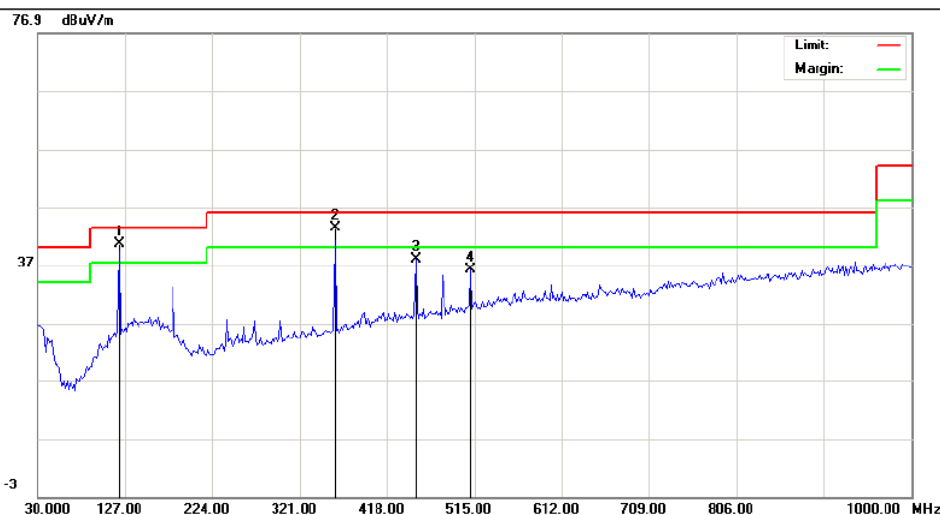

**Test Results - H (Measurement Distance: 3m)\_ Mid Band: 1960 MHz**

No.	Freq. MHz	Reading_Level (dBuV)			Correct Factor dB	Measurement (dBuV/m)			Limit (dBuV/m)		Margin (dB)		P/F
		Peak	QP	AVG		peak	QP	AVG	QP	AVG	QP	AVG	
1	120.5333	23.38	22.30		17.24	40.62	39.54		43.50		-3.96		P
2	359.8000	20.68			17.19	37.87			46.00		-8.13		P
3	450.3333	17.67			19.60	37.27			46.00		-8.73		P
4	479.4333	17.27			20.02	37.29			46.00		-8.71		P

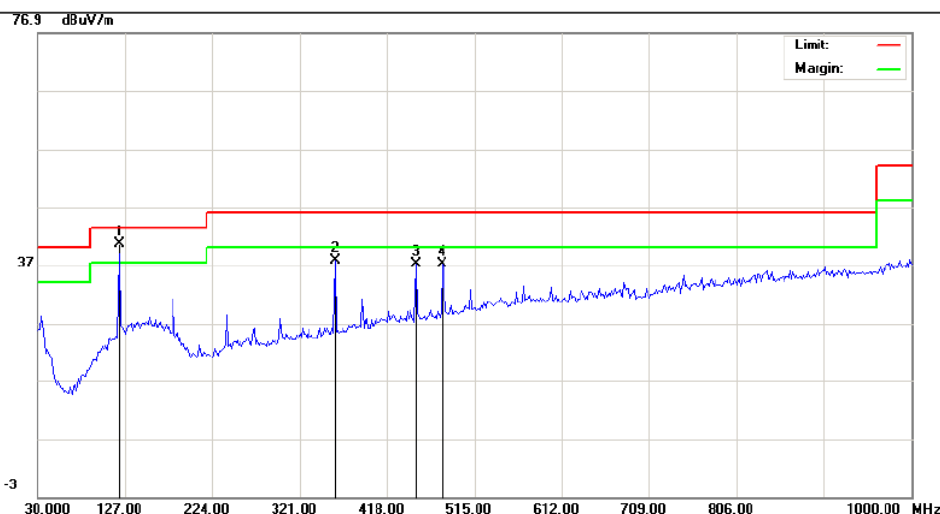

**Test Results - V (Measurement Distance: 3m)\_ Mid Band: 1960 MHz**

No.	Freq. MHz	Reading_Level (dBuV)			Correct Factor dB	Measurement (dBuV/m)			Limit (dBuV/m)		Margin (dB)		P/F
		Peak	QP	AVG		peak	QP	AVG	QP	AVG	QP	AVG	
1	120.5332	22.68	21.77		17.24	39.92	39.01		43.50		-4.49		P
2	359.8000	25.42	24.69		17.19	42.61	41.88		46.00		-4.12		P
3	450.3333	17.78			19.60	37.38			46.00		-8.62		P
4	479.4332	18.40			20.02	38.42			46.00		-7.58		P
5	510.1499	15.12			20.88	36.00			46.00		-10.00		P

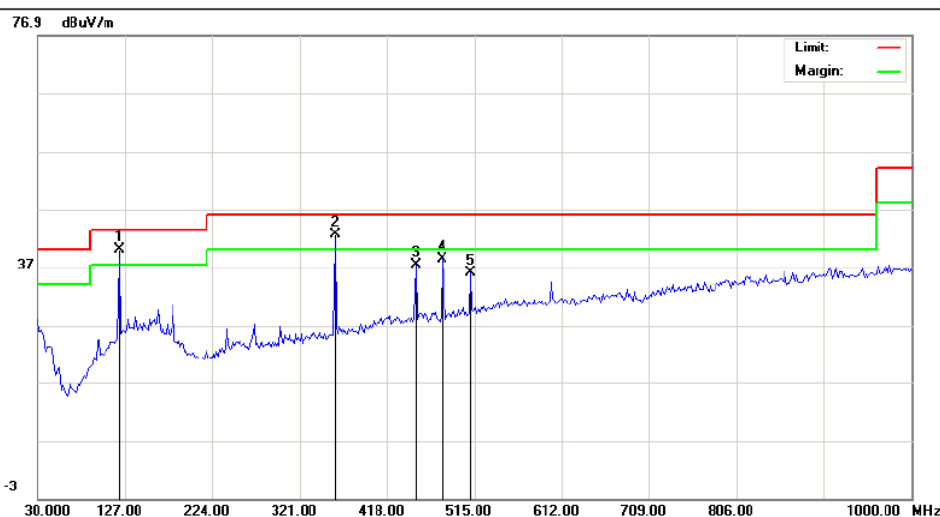

**Test Results - H (Measurement Distance: 3m)\_ Mid Band: 1987.5 MHz**

No.	Freq. MHz	Reading_Level (dBuV)			Correct Factor dB	Measurement (dBuV/m)			Limit (dBuV/m)		Margin (dB)		P/F
		Peak	QP	AVG		peak	QP	AVG	QP	AVG	QP	AVG	
1	120.5333	23.35	22.15		17.24	40.59	39.39	43.50		-4.11			P
2	359.8000	19.59			17.19	36.78		46.00		-9.22			P
3	450.3333	16.86			19.60	36.46		46.00		-9.54			P
4	479.4333	18.76			20.02	38.78		46.00		-7.22			P

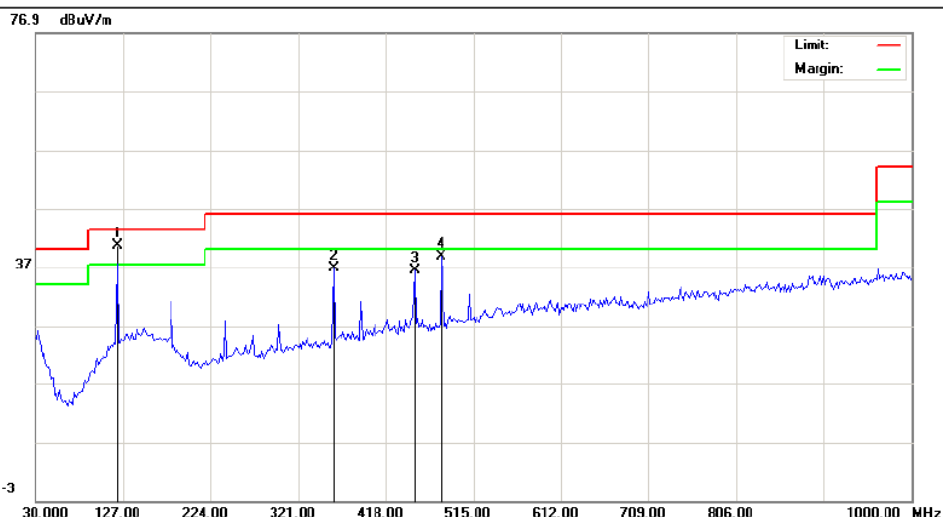

**Test Results - V (Measurement Distance: 3m)\_ Mid Band: 1987.5 MHz**

No.	Freq. MHz	Reading_Level (dBuV)			Correct Factor dB	Measurement (dBuV/m)			Limit (dBuV/m)		Margin (dB)		P/F
		Peak	QP	AVG		peak	QP	AVG	QP	AVG	QP	AVG	
1	97.9000	20.82			13.76	34.58		43.50		-8.92			P
2	120.5333	24.13	23.18		17.24	41.37	40.42	43.50		-3.08			P
3	359.8000	23.11	23.78		17.19	40.30	40.97	46.00		-5.03			P
4	450.3333	17.73			19.60	37.33		46.00		-8.67			P
5	479.4333	17.26			20.02	37.28		46.00		-8.72			P

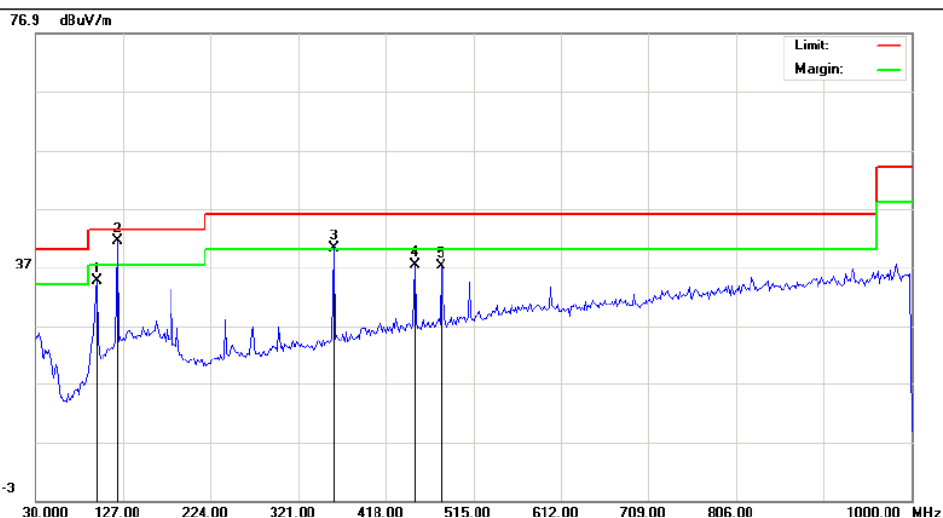

### 10.4.4. Results for Radiated Emissions (1-6 GHz)

Test Results - H (Measurement Distance: 1m)_Low Band: 1932.5MHz						
Frequency (MHz)	Reading Level _ Peak (dB $\mu$ V/m)	Factor (dB)	Measurement (dB $\mu$ V/m)	Limit @1m _ AVG (dB $\mu$ V/m)	Margin (dB)	Result (P/F)
1932.500	73.60	5.65	79.25	--	--	--
5800.000	35.69	12.45	48.14	64.00	-15.86	P

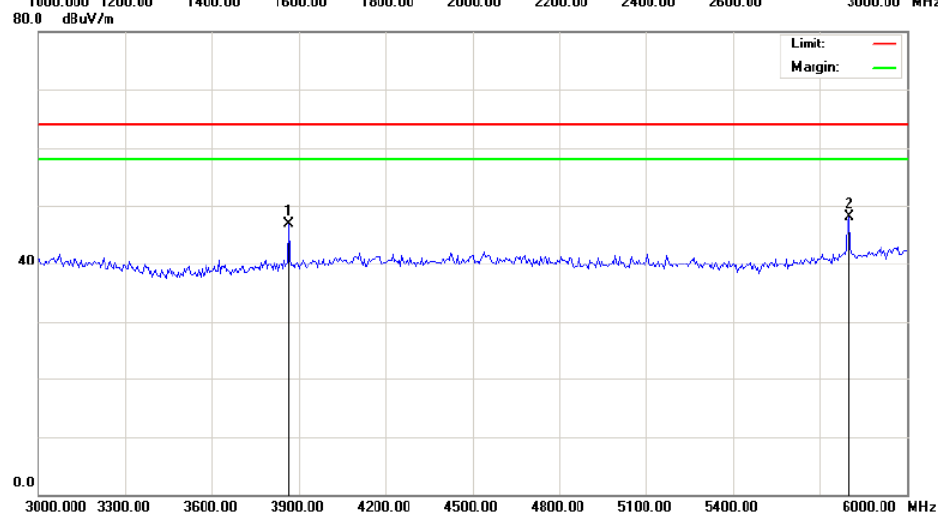
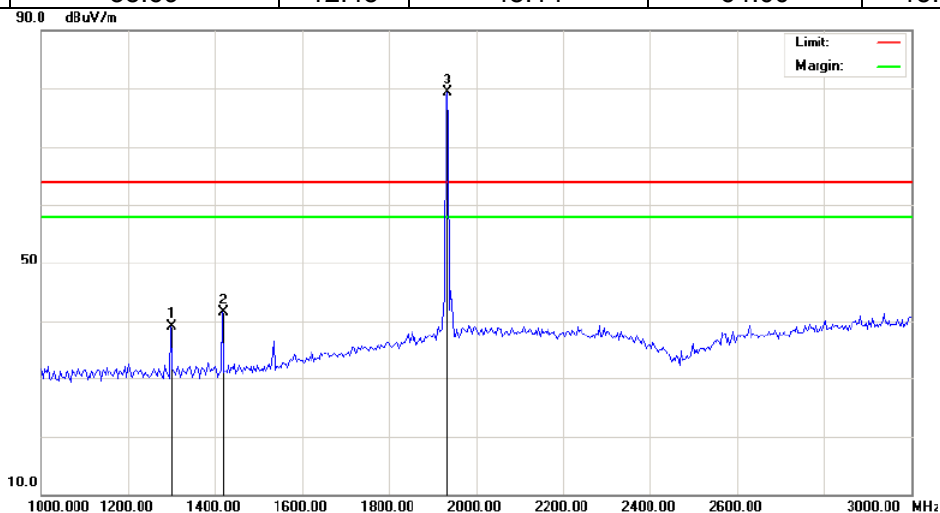

Test Results - V (Measurement Distance: 1m) _Low Band: 1932.5MHz						
Frequency (MHz)	Reading Level _ Peak (dB $\mu$ V/m)	Factor (dB)	Measurement (dB $\mu$ V/m)	Limit @1m _ AVG (dB $\mu$ V/m)	Margin (dB)	Result (P/F)
1932.500	70.54	5.65	76.19	--	--	--
5800.000	39.19	12.45	51.64	64.00	-12.36	P

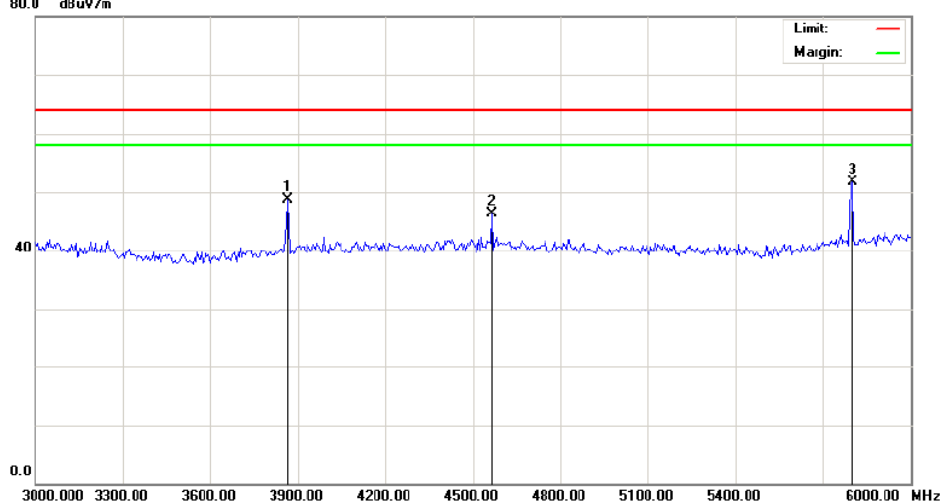
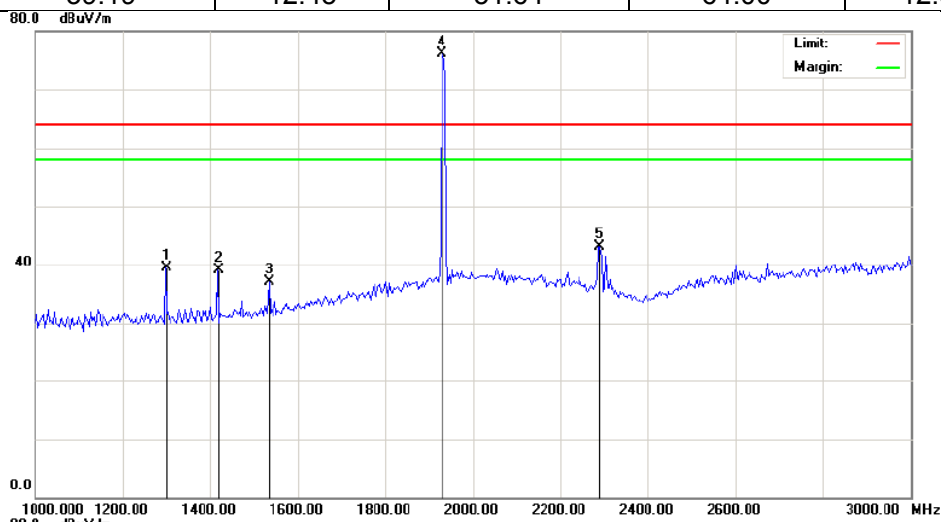

Test Results - H (Measurement Distance: 1m)_Mid Band: 1960MHz						
Frequency (MHz)	Reading Level _ Peak (dB $\mu$ V/m)	Factor (dB)	Measurement (dB $\mu$ V/m)	Limit @1m _ AVG (dB $\mu$ V/m)	Margin (dB)	Result (P/F)
1960.000	73.73	6.11	79.84	--	--	--
3920.000	45.70	9.67	55.37	64.00	-8.63	P

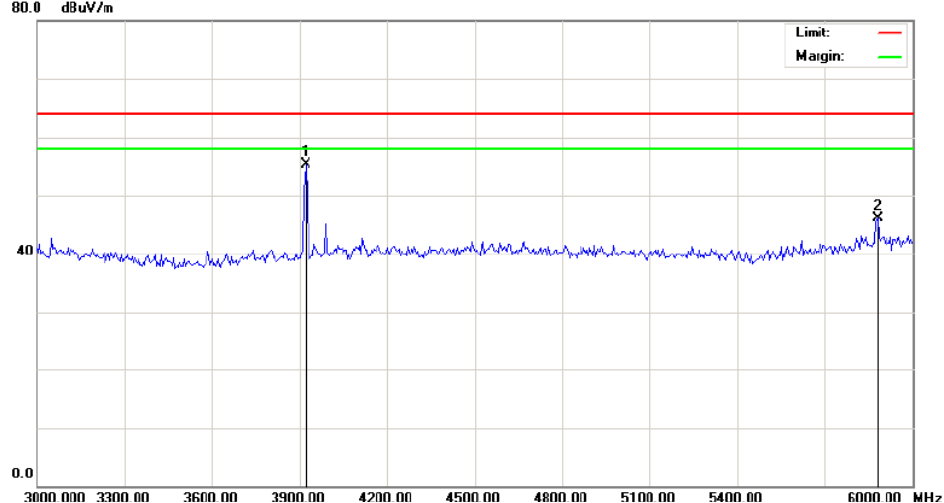
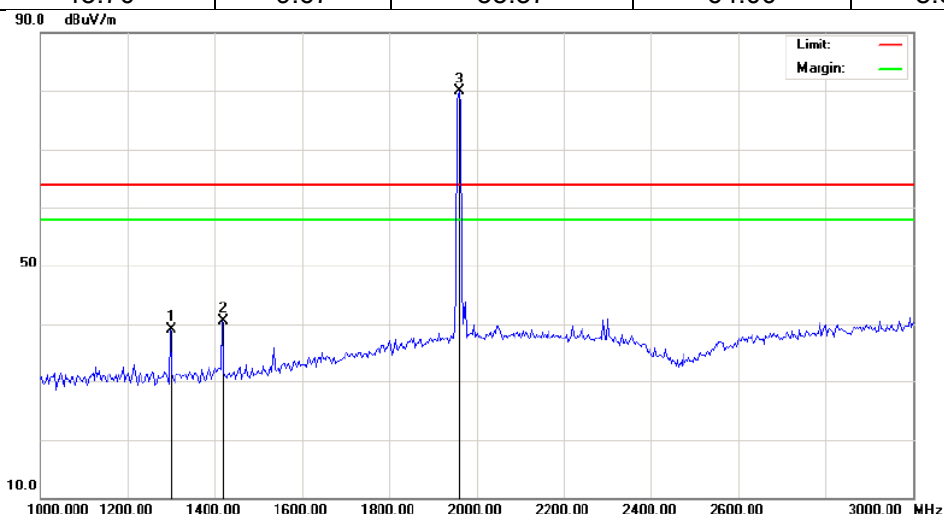

Test Results - V (Measurement Distance: 1m) _ Mid Band: 1960MHz						
Frequency (MHz)	Reading Level _ Peak (dB $\mu$ V/m)	Factor (dB)	Measurement (dB $\mu$ V/m)	Limit @1m _ AVG (dB $\mu$ V/m)	Margin (dB)	Result (P/F)
1960.000	71.95	6.11	78.06	--	--	--
3920.000	48.12	9.67	57.79	64.00	-6.21	P

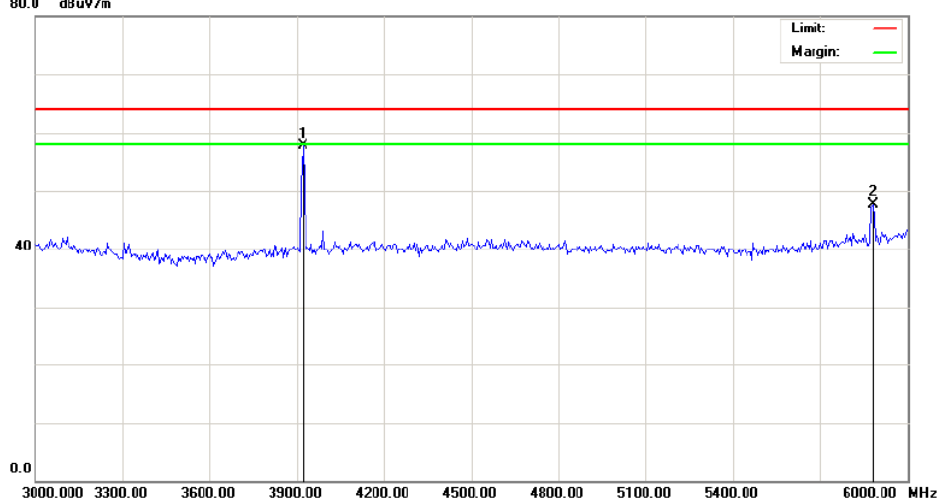
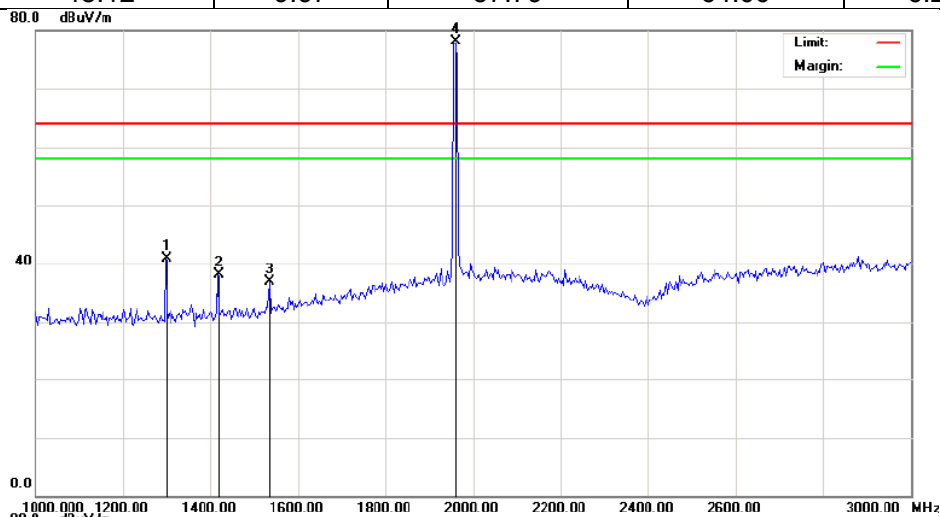

Test Results - H (Measurement Distance: 1m)_High Band: 1987.5MHz						
Frequency (MHz)	Reading Level _ Peak (dB $\mu$ V/m)	Factor (dB)	Measurement (dB $\mu$ V/m)	Limit @1m _ AVG (dB $\mu$ V/m)	Margin (dB)	Result (P/F)
1987.500	72.22	6.52	78.74	--	--	--
5965.000	39.86	13.40	53.26	64.00	-10.74	P

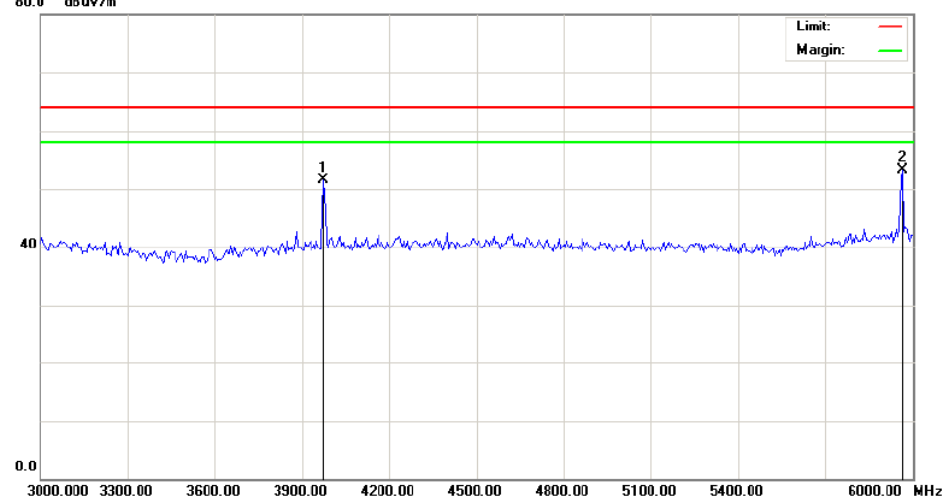
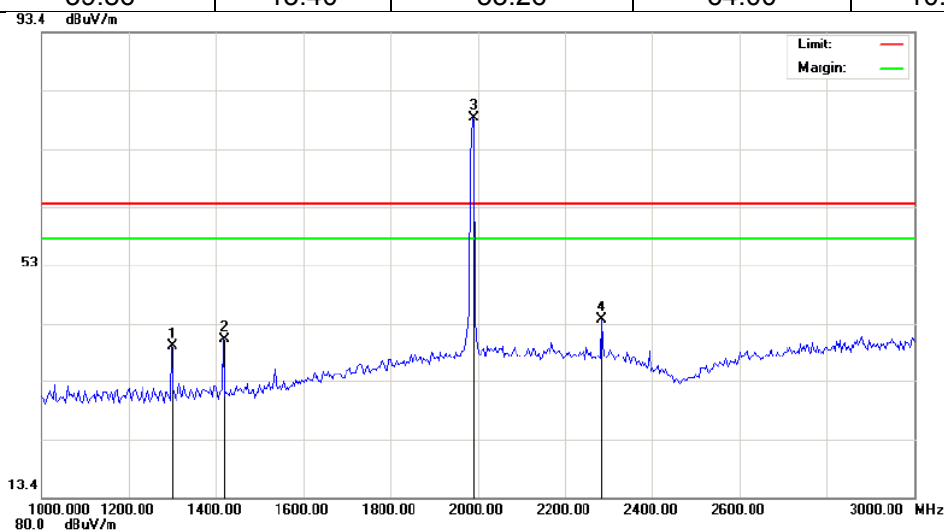



Test Results - V (Measurement Distance: 1m) _ High Band: 1987.5MHz						
Frequency (MHz)	Reading Level _ Peak (dB $\mu$ V/m)	Factor (dB)	Measurement (dB $\mu$ V/m)	Limit @1m _ AVG (dB $\mu$ V/m)	Margin (dB)	Result (P/F)
1987.500	73.97	6.52	80.49	--	--	--
3975.000	48.02	9.96	57.98	64.00	-6.02	P

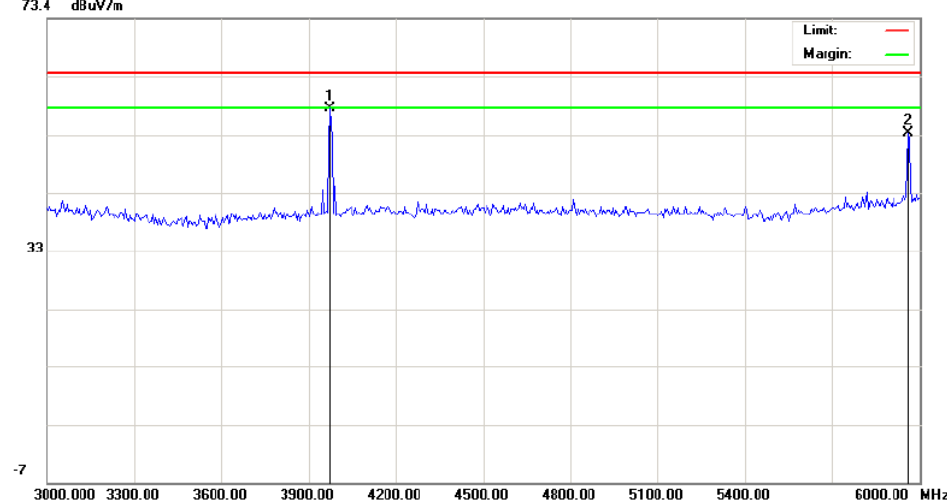
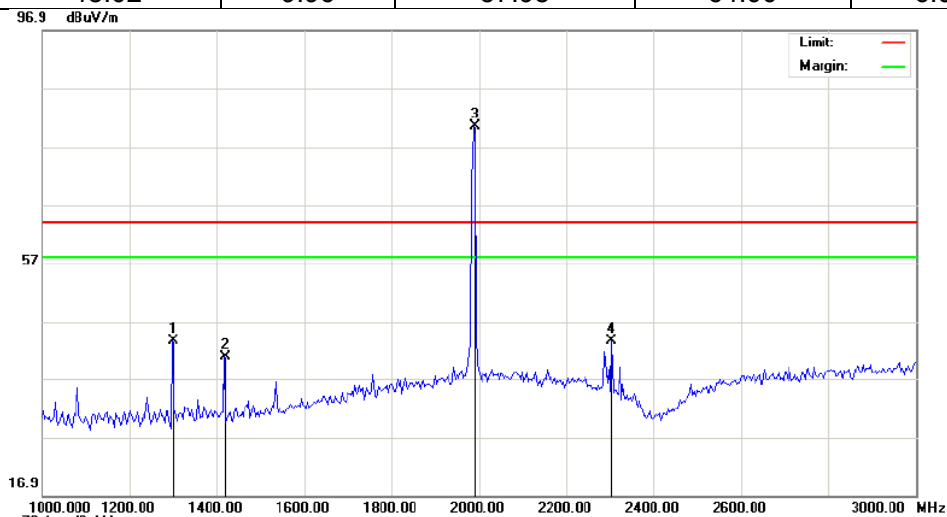

### 10.4.4. Results for Radiated Emissions (above 6 GHz)

Test Results (Measurement Distance: 1m)						
Frequency (MHz)	Reading Level - Peak (dB $\mu$ V/m)	Factor (dB)	Measurement (dB $\mu$ V/m)	Limit @1m - AVG (dB $\mu$ V/m)	Margin (dB)	Result (P/F)
--	--	--	--	--	--	--

No suspicious frequency found in this band.

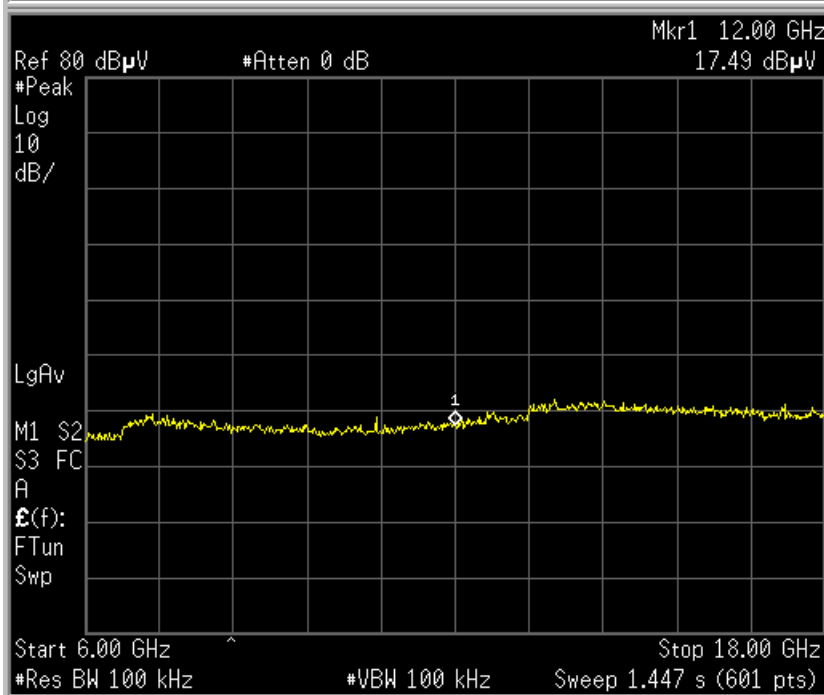
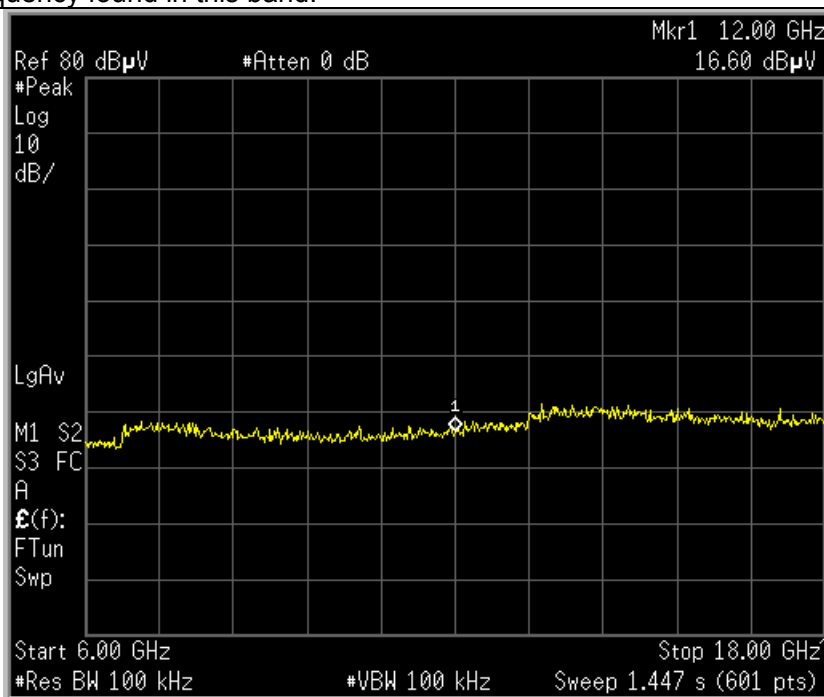

## 11. RADIATED SPURIOUS EMISSIONS MEASUREMENT

### 11.1. LIMITS

Frequency (MHz)	Field strength (dB $\mu$ V/m)	Distance (m)
1930 & 1990	64	1

**Note:** the tighter limit applies at the band edges.

### 11.2. BLOCK DIAGRAM OF TEST SETUP

See section 10.2.

### 11.3. TEST PROCEDURE

See section 10.3.

### 11.4. TEST RESULT

Operation Band	Center Frequency (MHz)	Measurement - H		Measurement - V		Limit AVG (dB $\mu$ V/m)	Result (P/F)
		Frequency (MHz)	Peak (dB $\mu$ V/m)	Frequency (MHz)	Peak (dB $\mu$ V/m)		
Low	1932.5	1929.77	38.47	1929.78	43.05	47	P
High	1987.5	1990.13	34.65	1990.13	32.07	47	P

### 11.5. GRAPH

For Low Band: 1932.5MHz

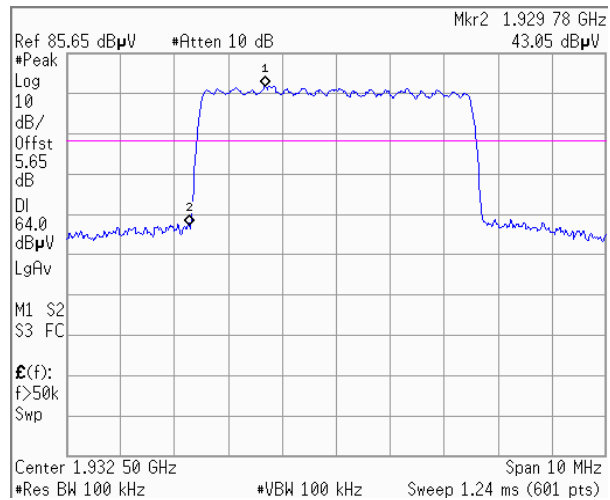
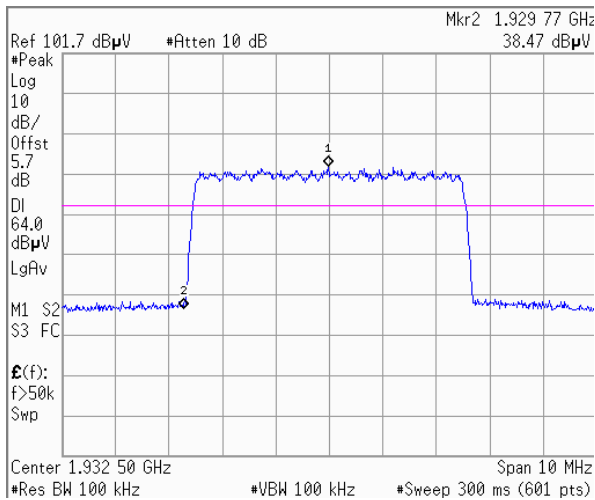

For High Band: 1987.5MHz

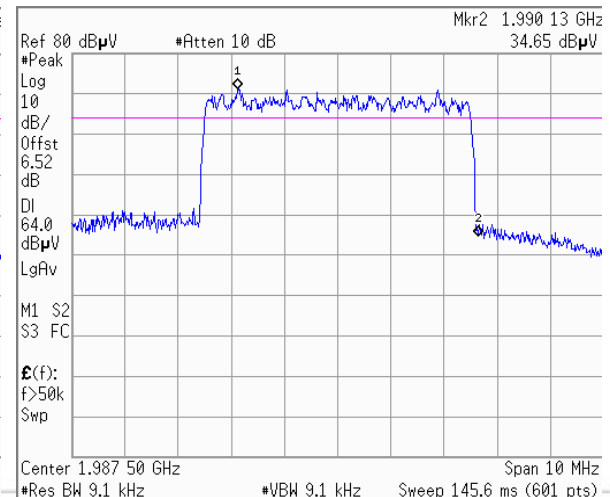
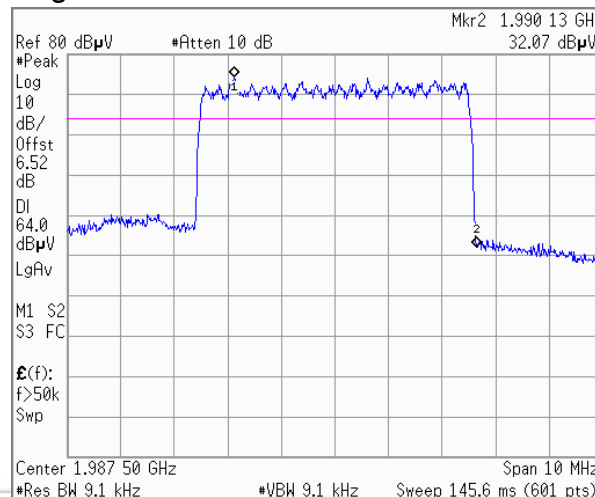

## APPENDIX 1 PHOTOGRAPHS OF TEST SETUP

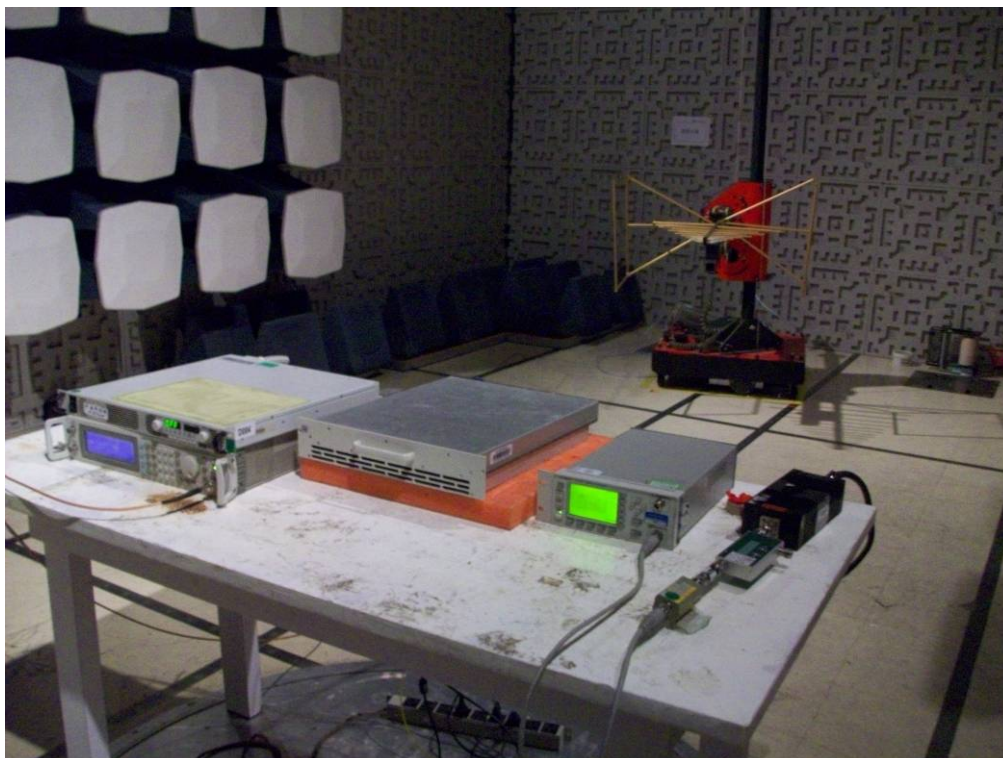

**IDEAL TEST SETUP OF RADIATED TEST – FRONT VIEW**

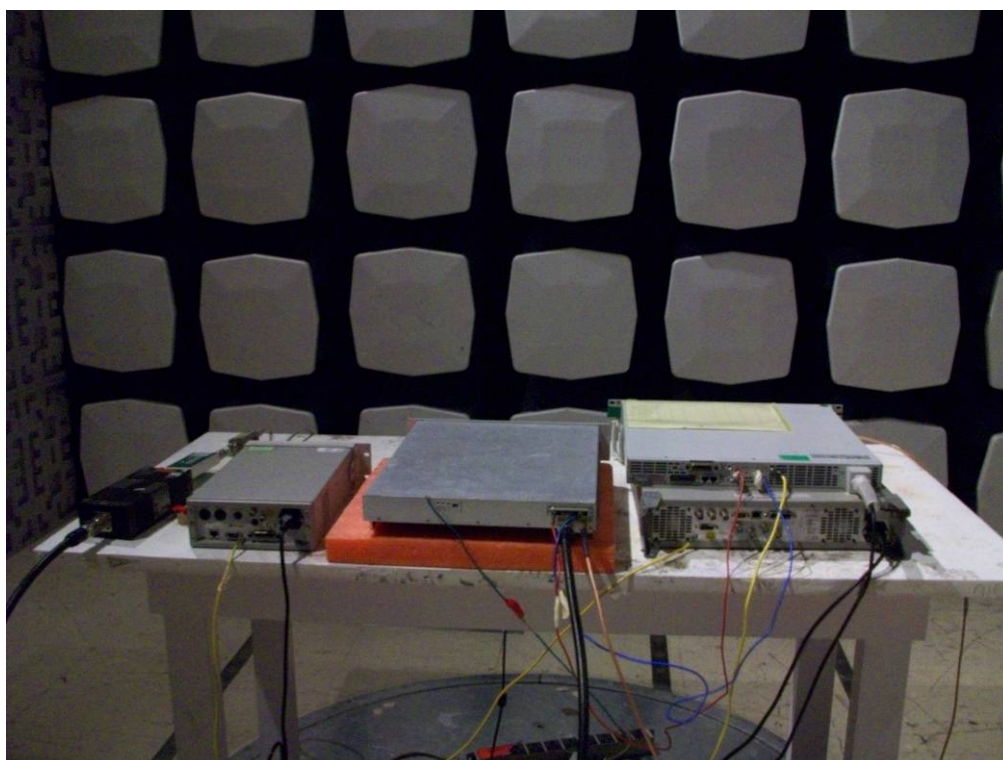

**IDEAL TEST SETUP OF RADIATED TEST – BACK VIEW**



**TEST SETUP OF RADIATED EMISSION (9kHz-30MHz)**



**TEST SETUP OF RADIATED EMISSION (30MHz-1GHz)**



**TEST SETUP OF RADIATED EMISSION (above 1GHz)**

## APPENDIX 2 EXTERNAL PHOTOGRAPHS OF EUT



TOP VIEW



BOTTOM VIEW



FRONT VIEW



BACK VIEW



DETAIL VIEW



## APPENDIX 3 INTERNAL PHOTOGRAPHS OF EUT

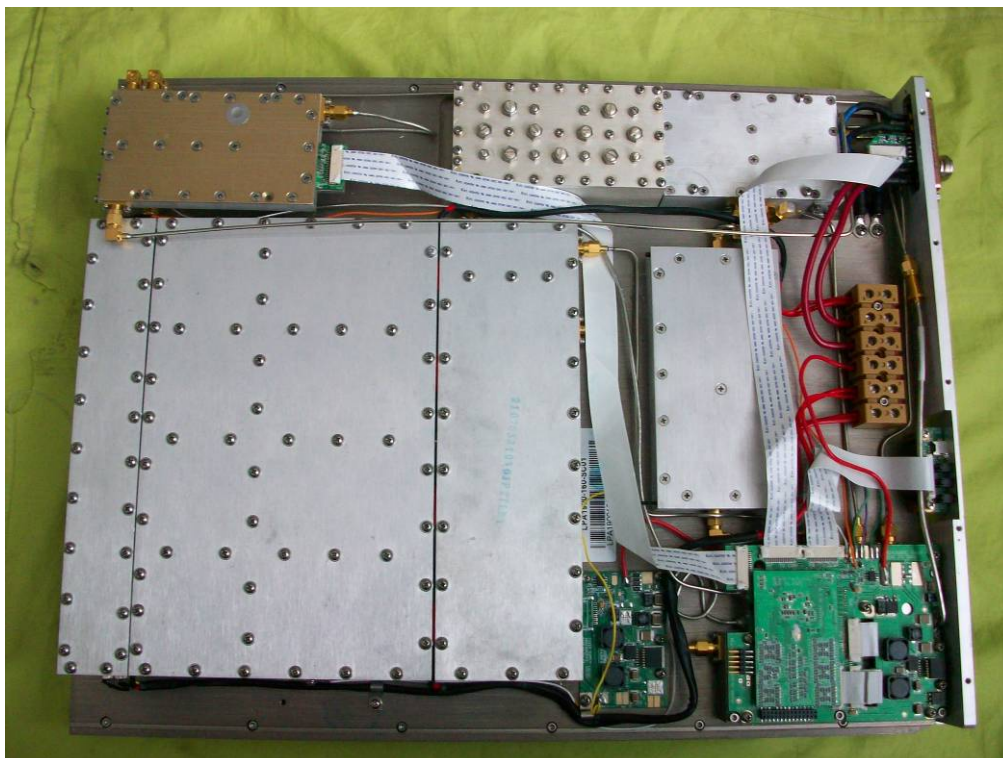

TOP VIEW WITHOUT OUTER COVER (COVER\_1)

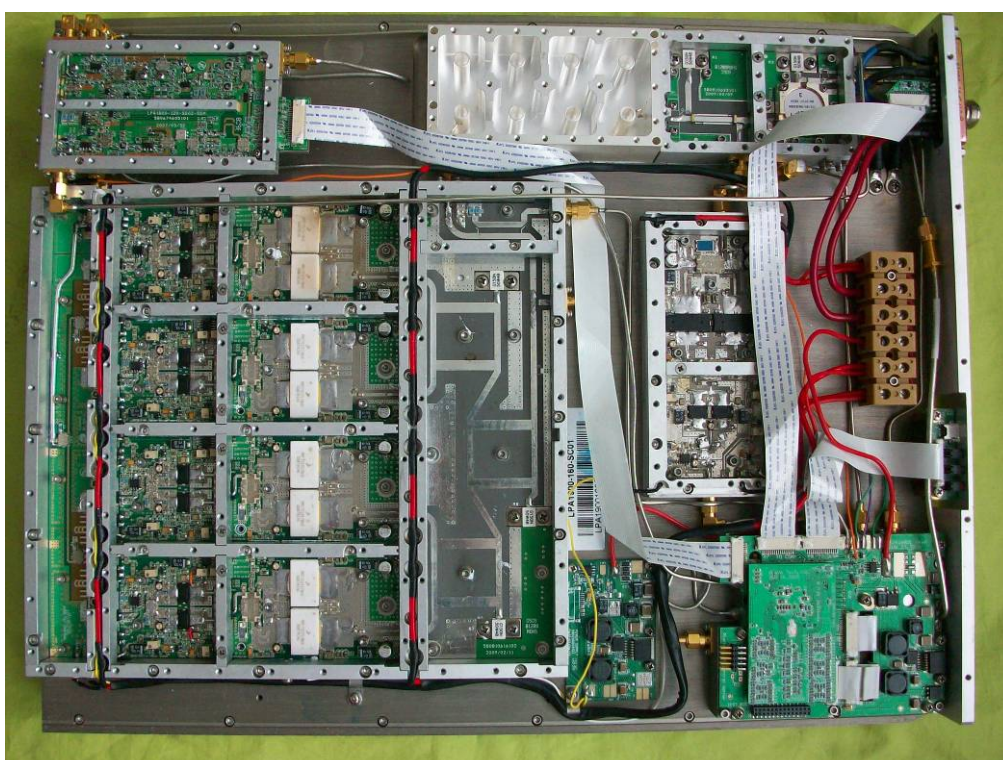

TOP VIEW WITHOUT INTERNAL COVERS (COVER\_2s)

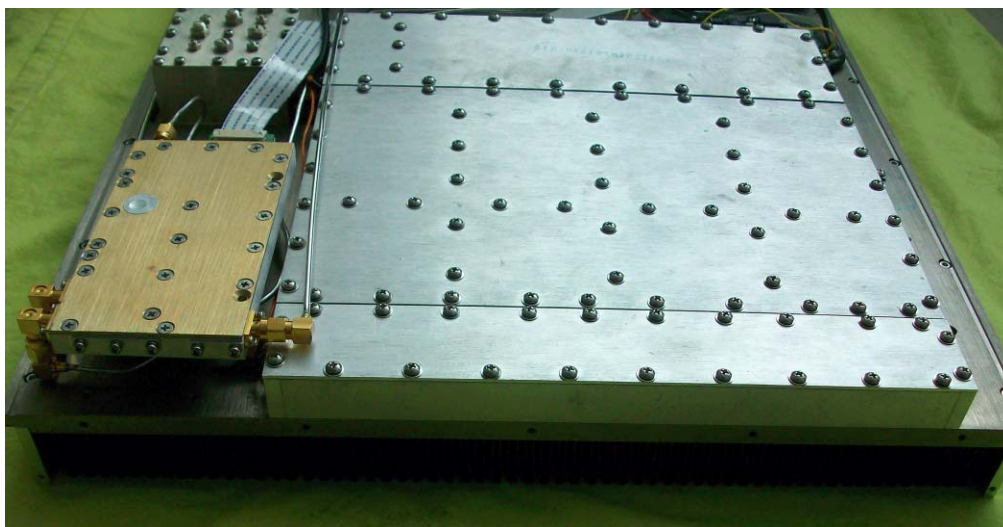

SIDE VIEW WITHOUT COVER\_1 -1



SIDE VIEW WITHOUT COVER\_1 -2

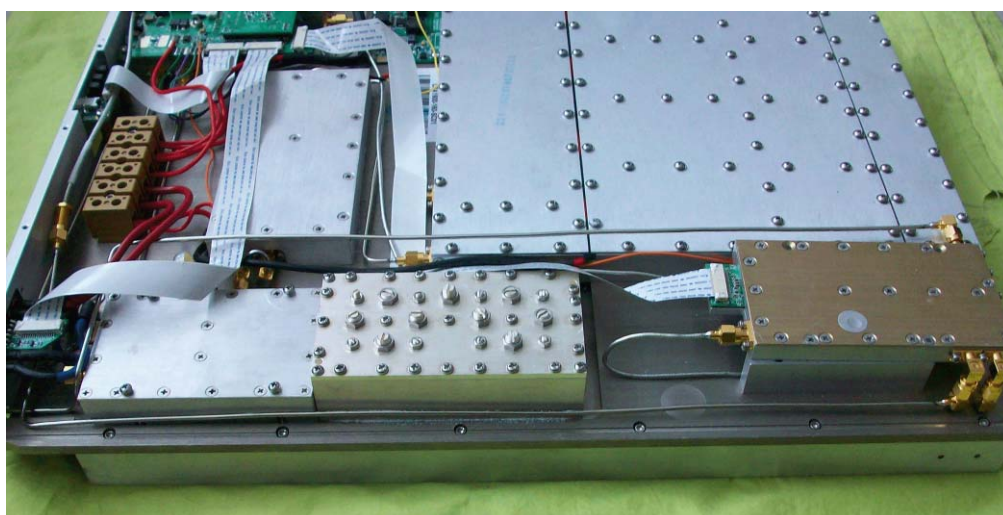

SIDE VIEW WITHOUT COVER\_1 -3

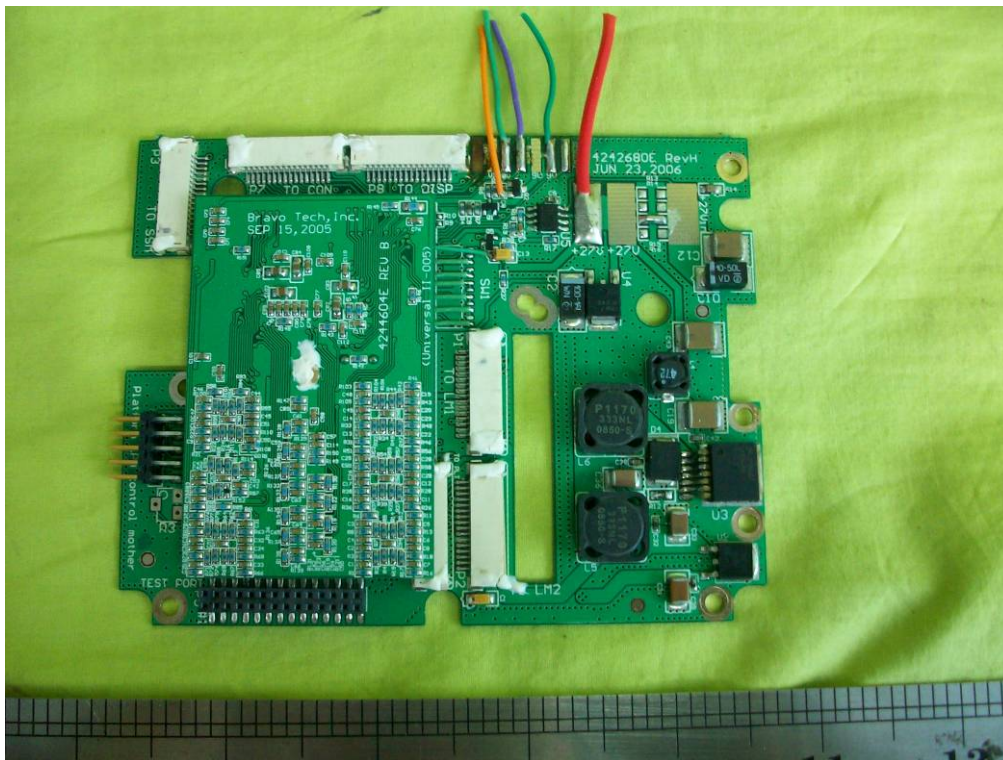

TOP VIEW OF MODULE (MODULE\_1)

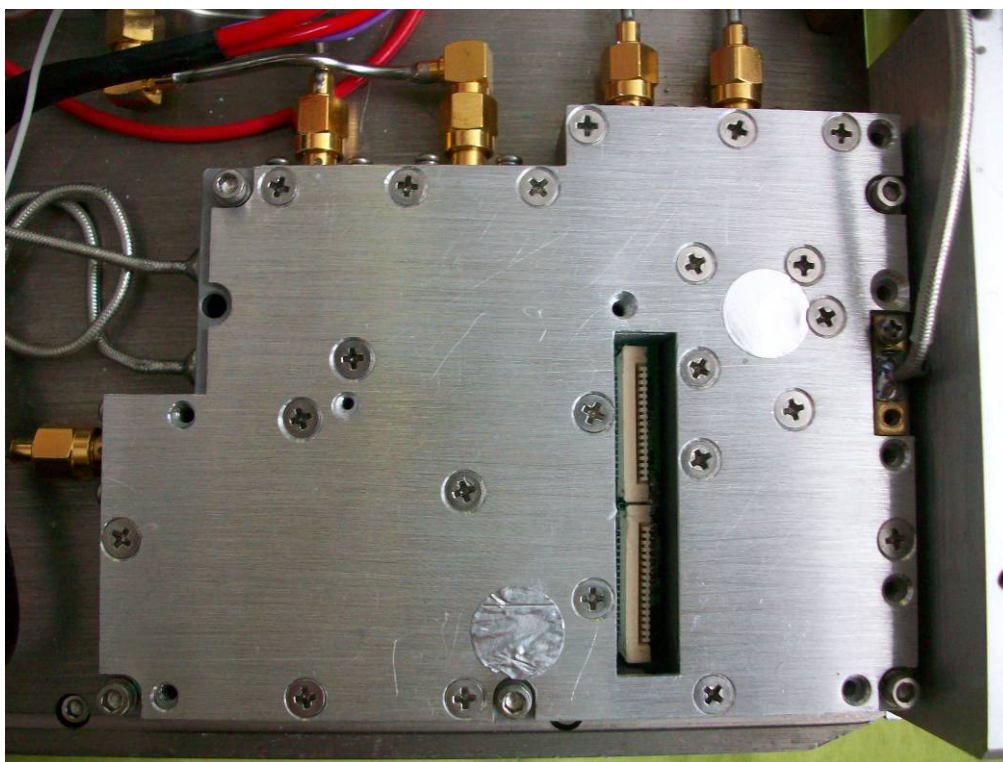

TOP VIEW OF COVER (COVER\_3) WITHOUT MODULE\_1

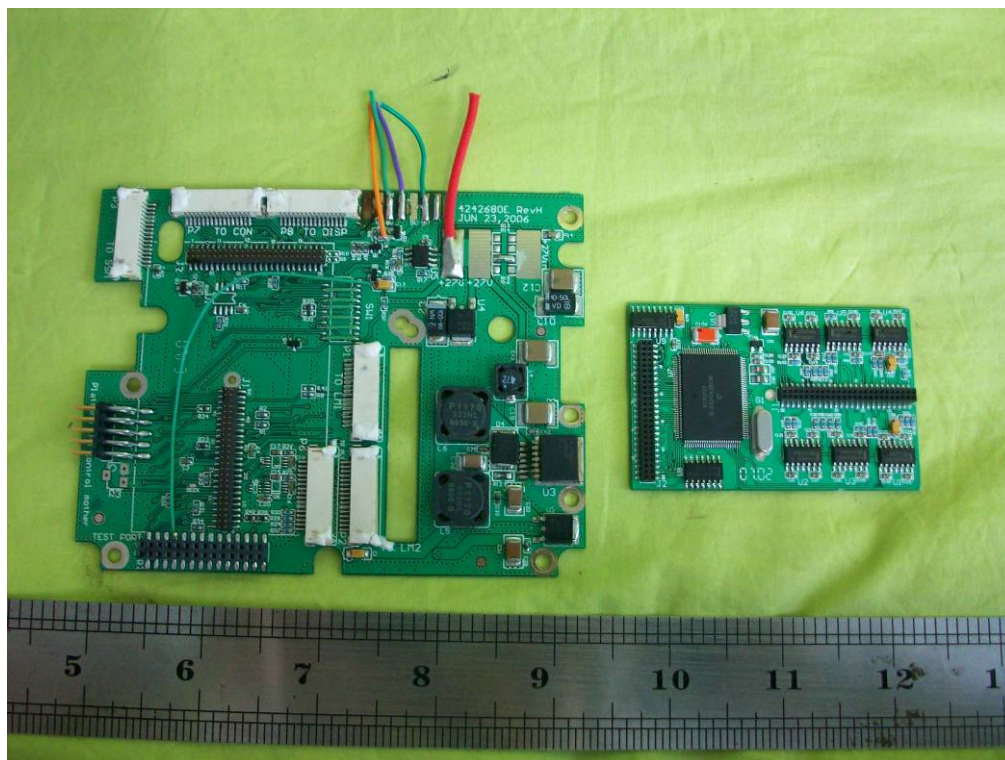

TOP VIEW OF PARTS OF MODULE\_1

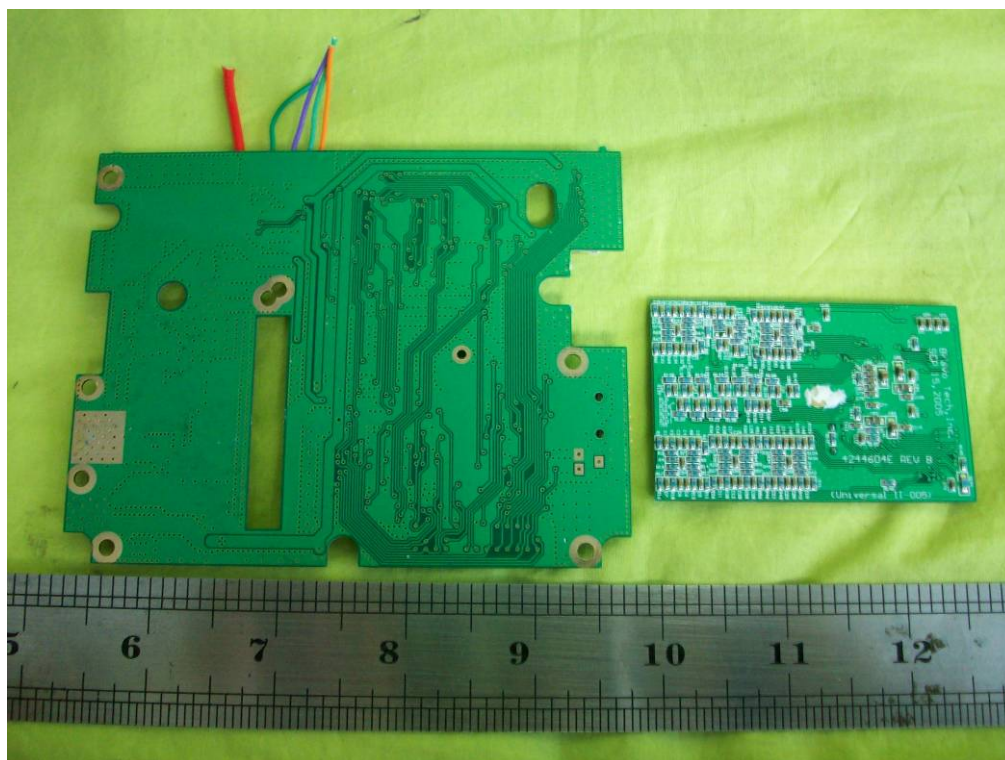

BOTTOM VIEW OF PARTS OF MODULE\_1

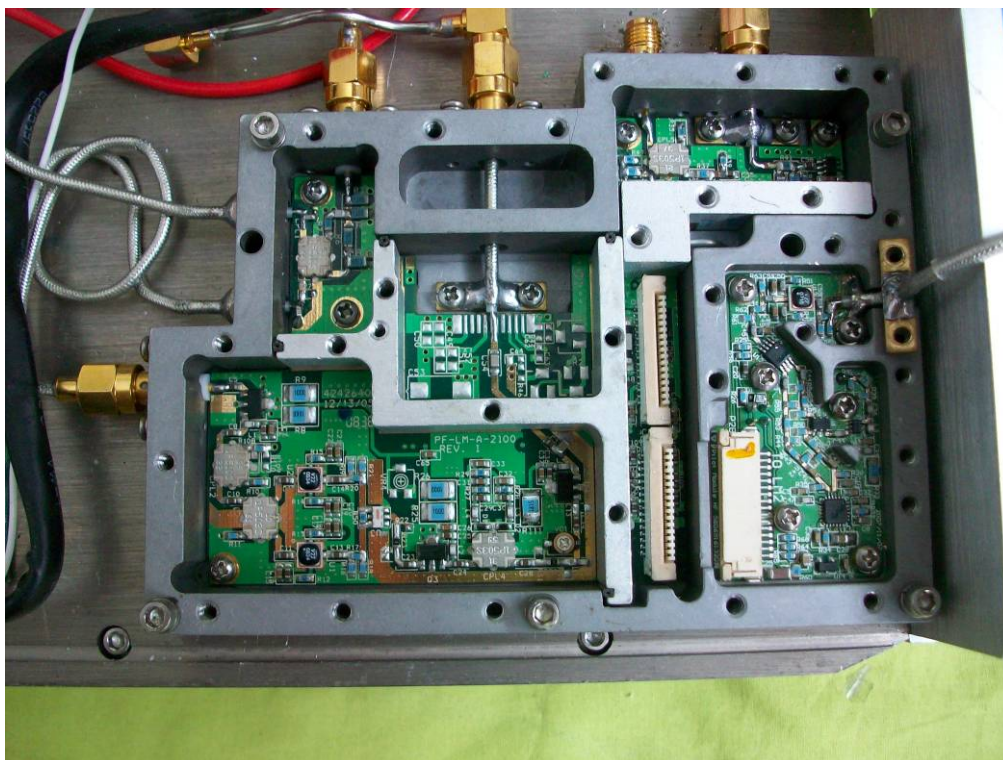

TOP VIEW OF MODULE (MODULE\_2) WITHOUT COVER\_3

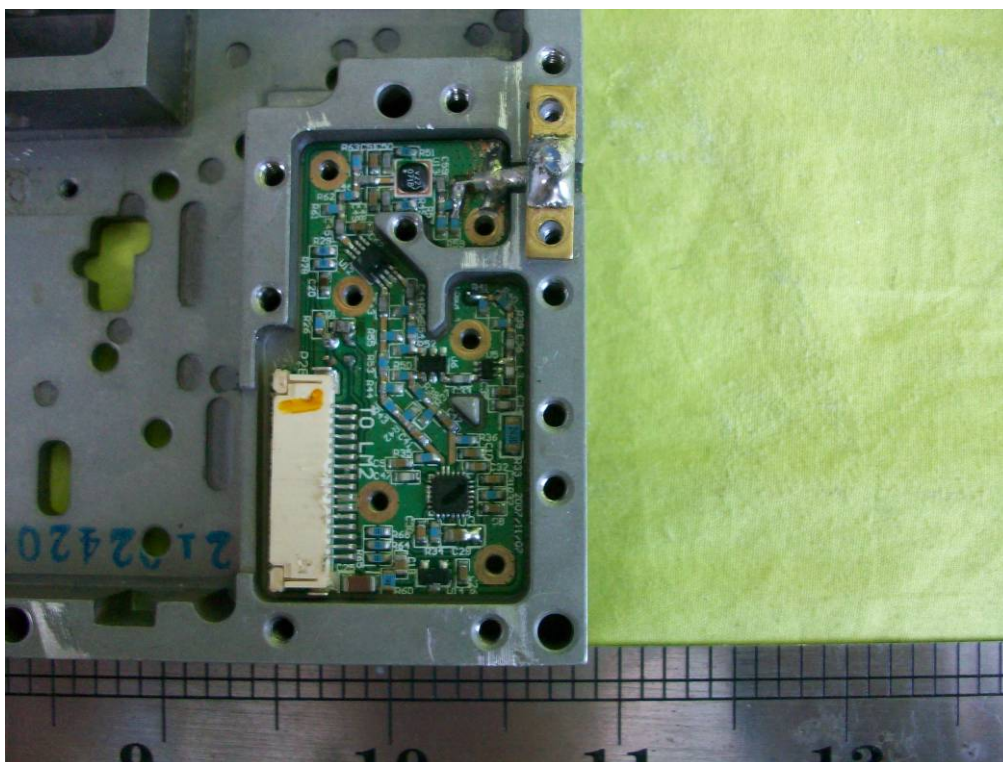

TOP VIEW OF PART (MODULE\_2\_2) OF MODULE\_2

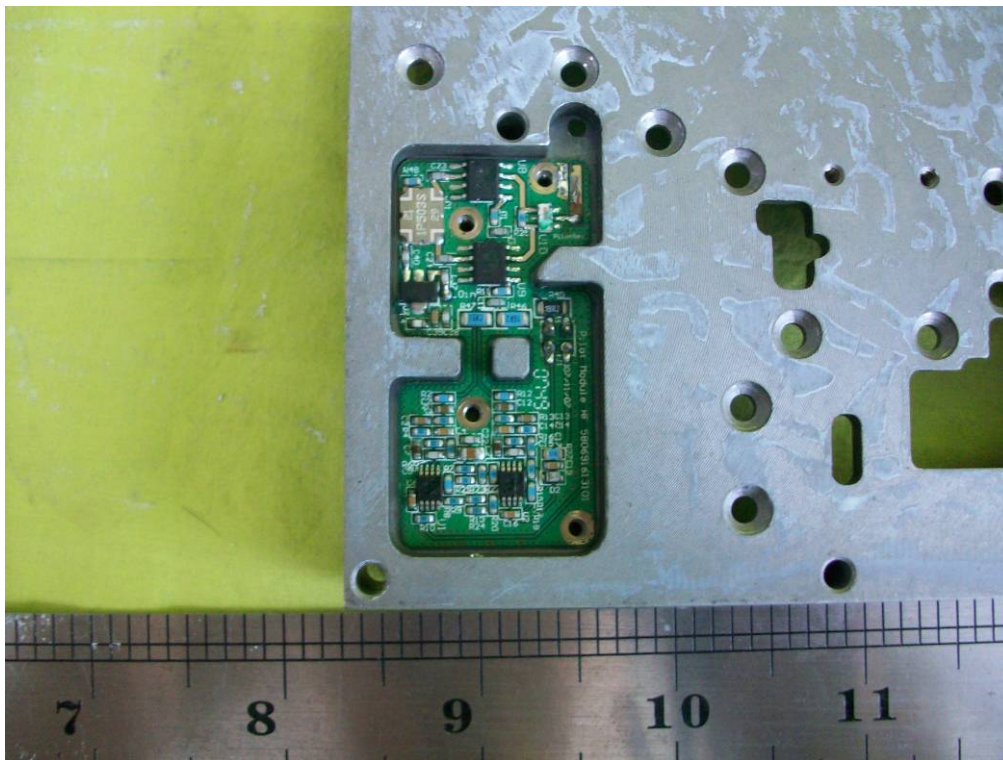

BOTTOM VIEW OF MODULE\_2\_2 OF MODULE\_2  
NOTE: MODUL\_2\_2 includes two PCBs installed together

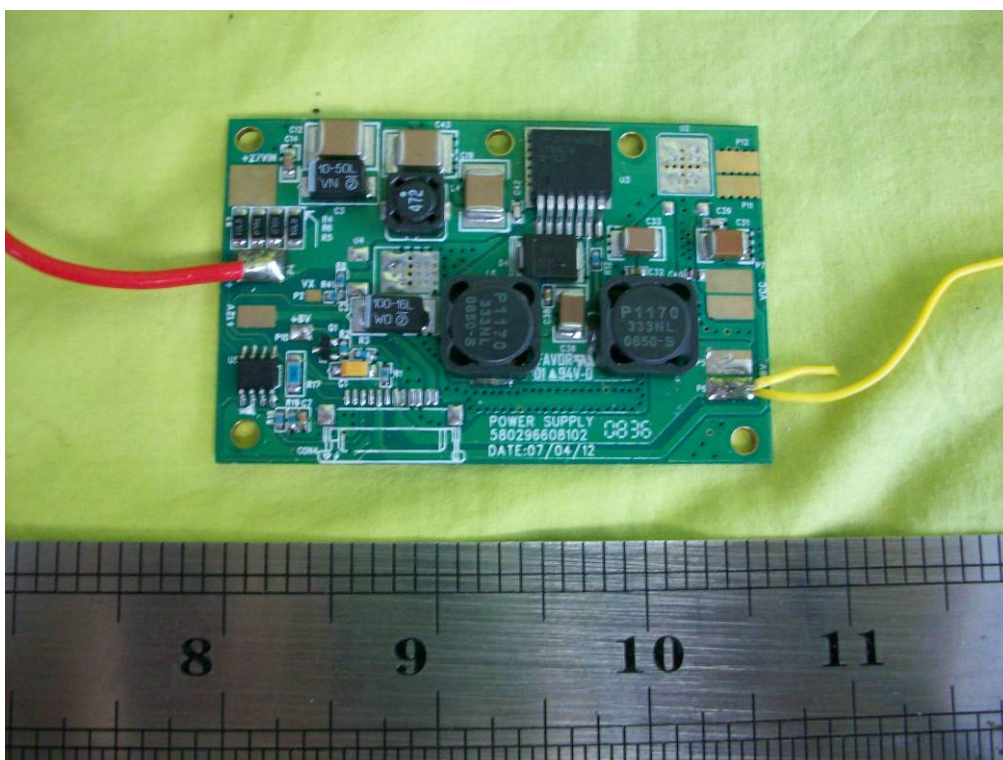

TOP VIEW OF MODULE (MODULE\_3)

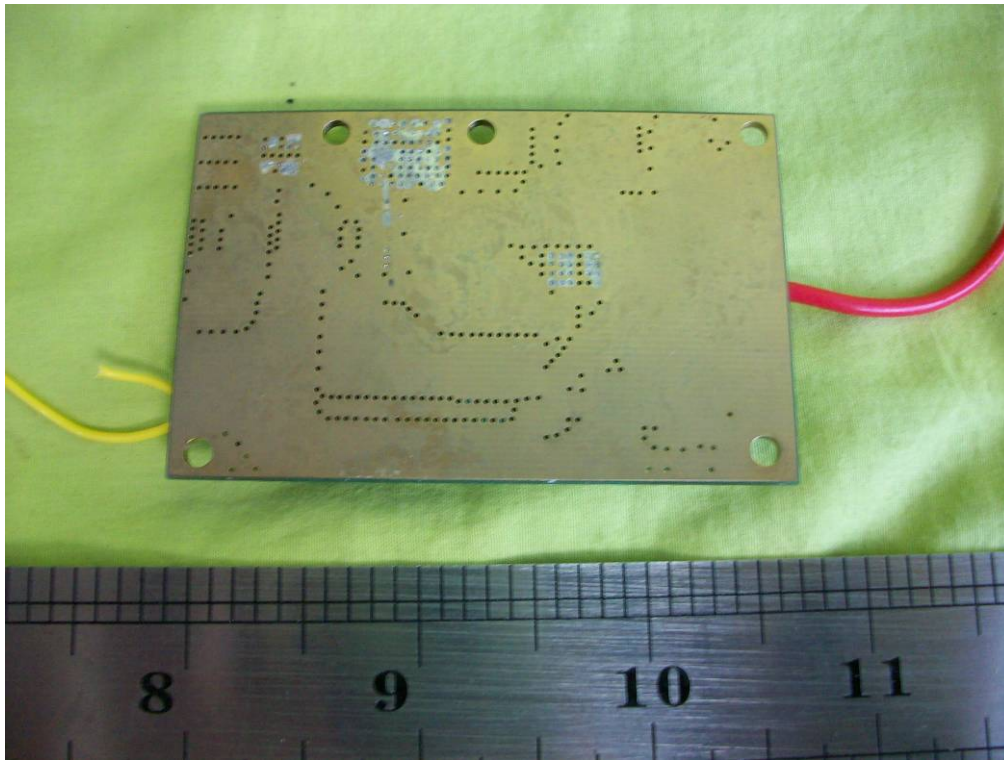

BOTTOM VIEW OF MODULE\_3

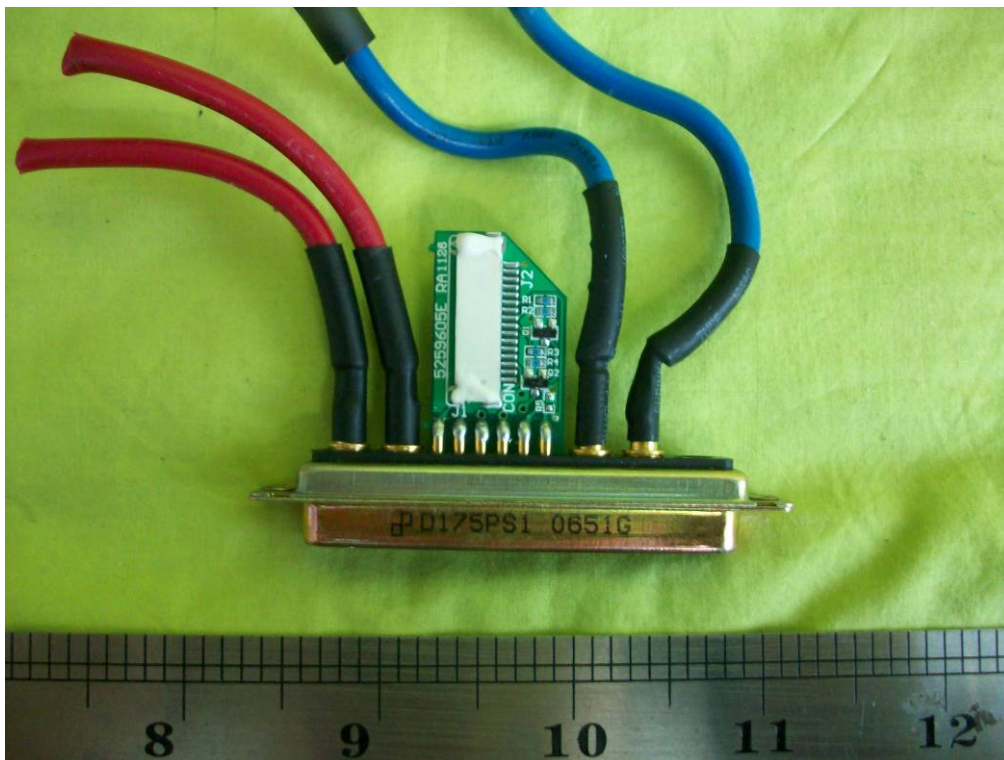

TOP VIEW OF MODULE (MODUL\_4)

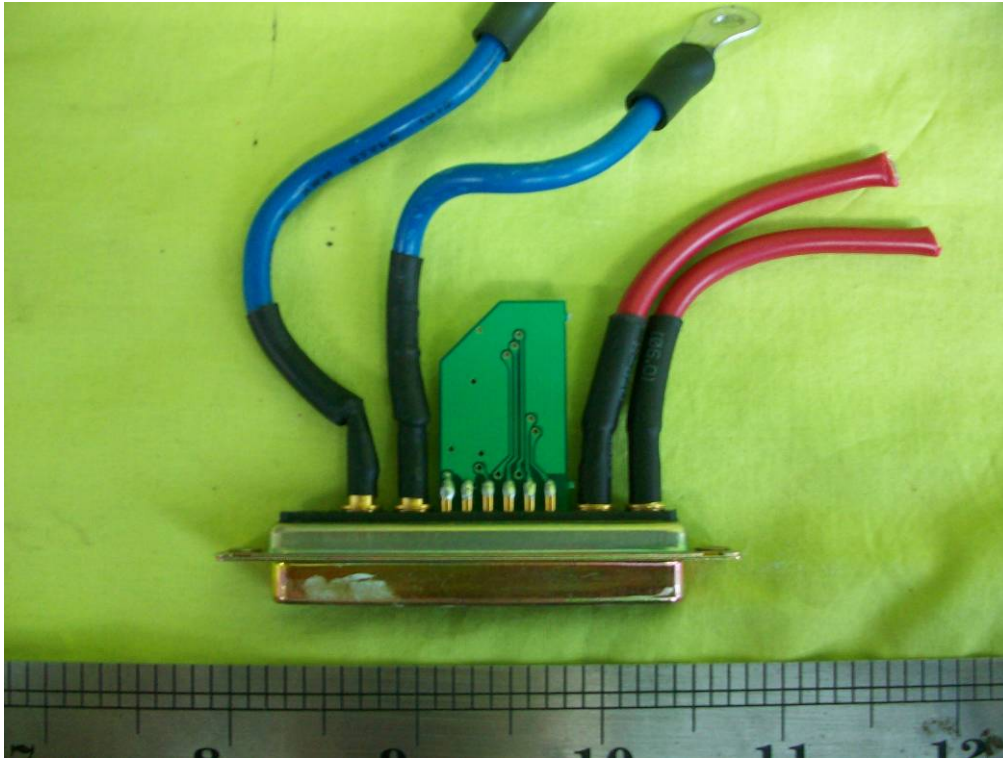

BOTTOM VIEW OF MODUL\_4

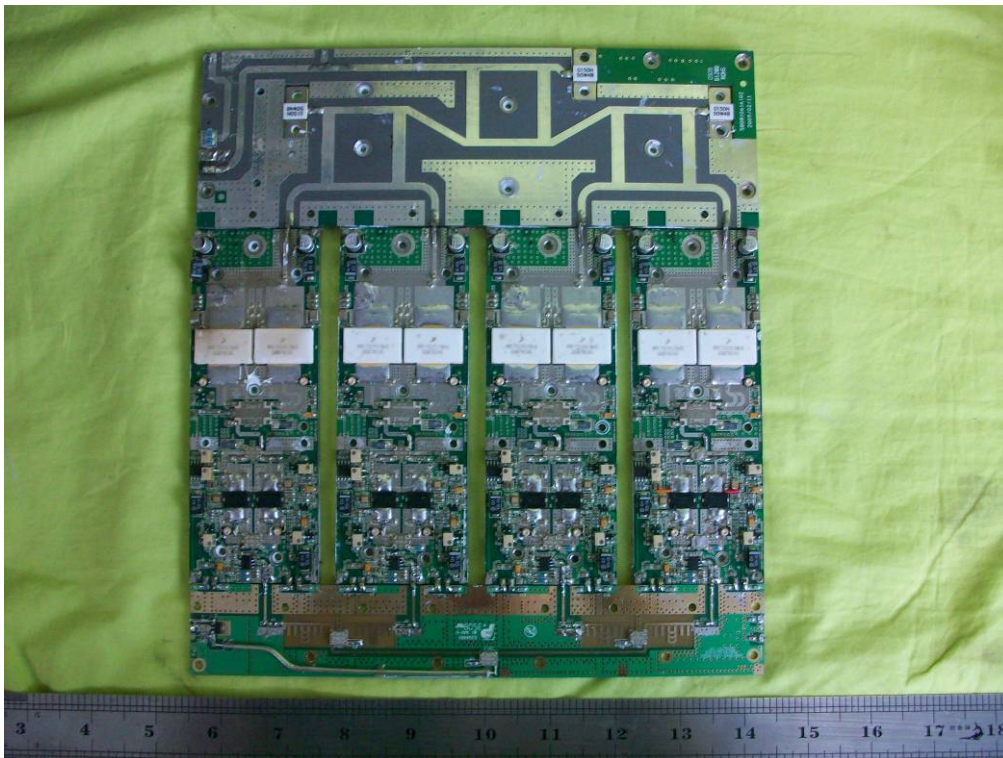

TOP VIEW OF MODULE (MODUL\_5)



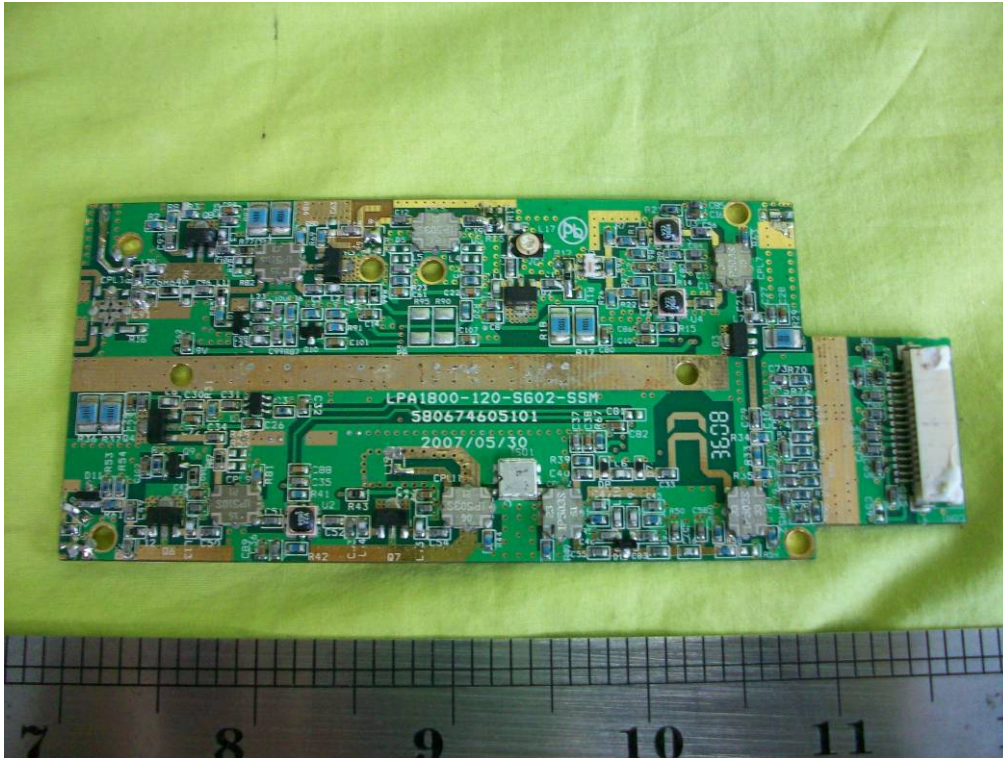

TOP VIEW OF MODULE (MODUL\_6)

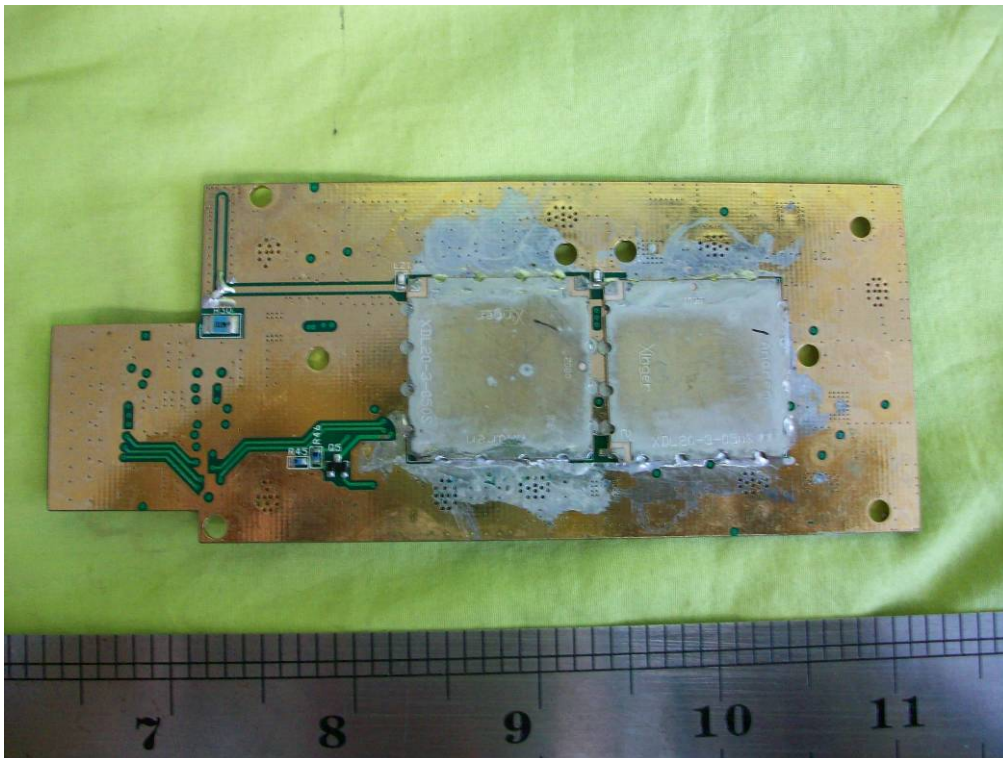

BOTTOM VIEW OF MODUL\_6

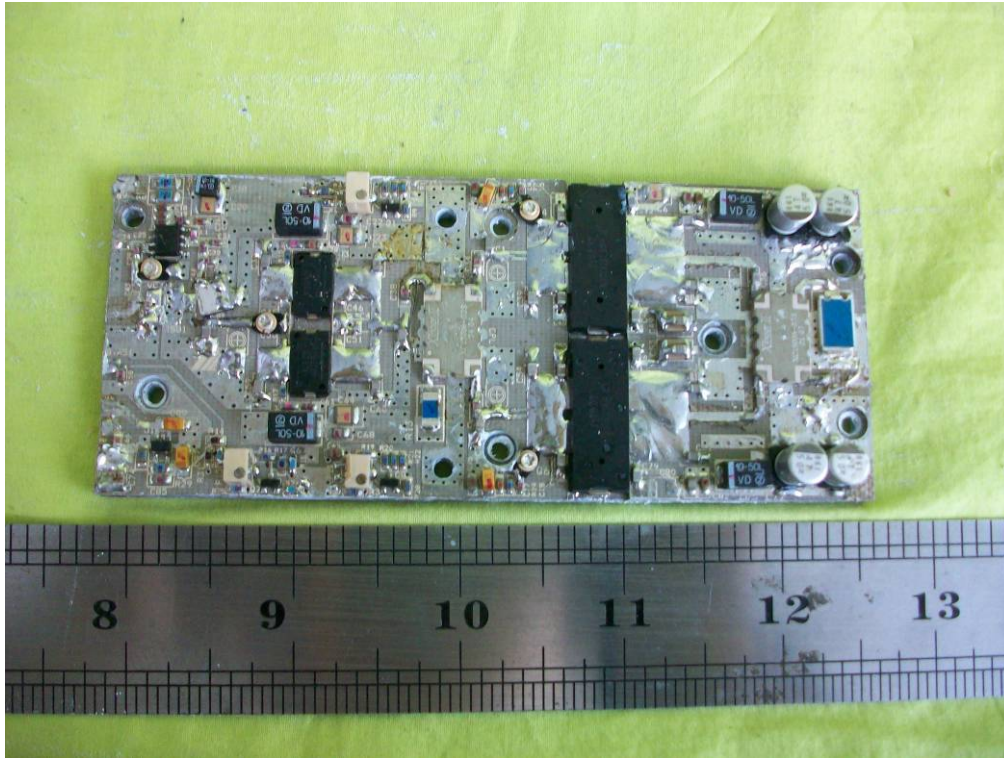

TOP VIEW OF MODULE (MODUL\_7)

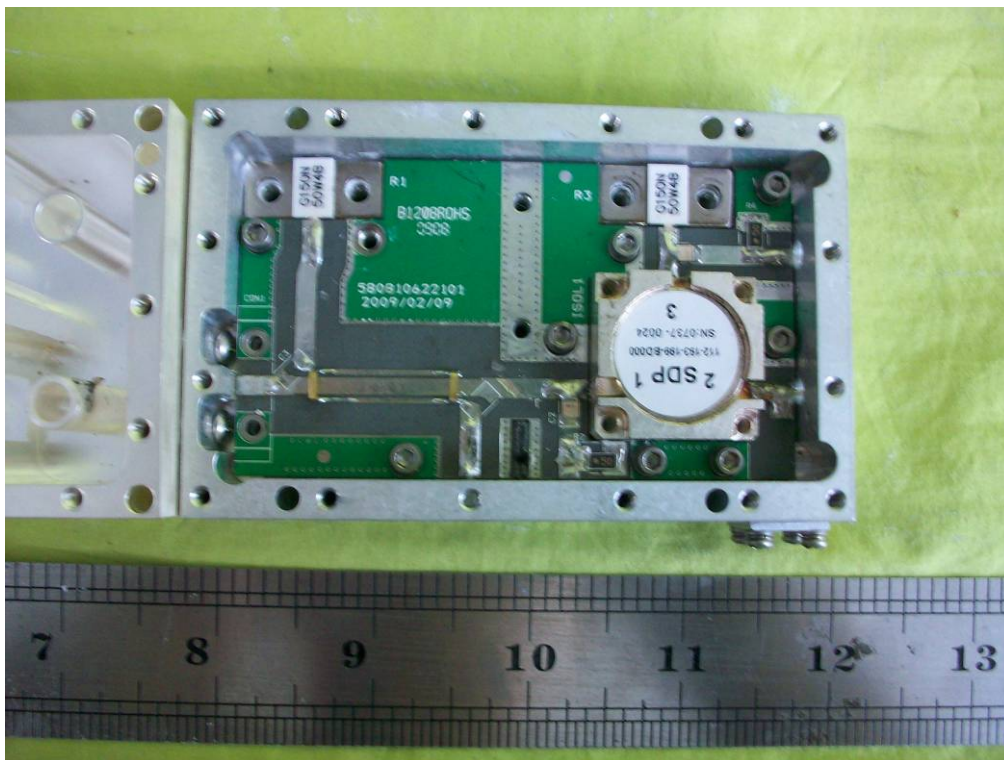

TOP VIEW OF MODULE (MODUL\_8)

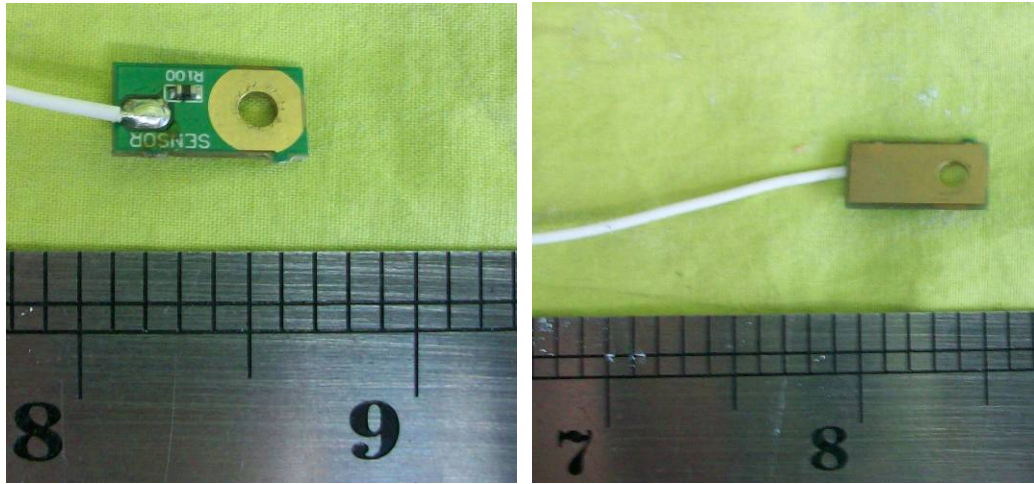

TOP & BOTTOM VIEW OF MODULE (MODUL\_9)

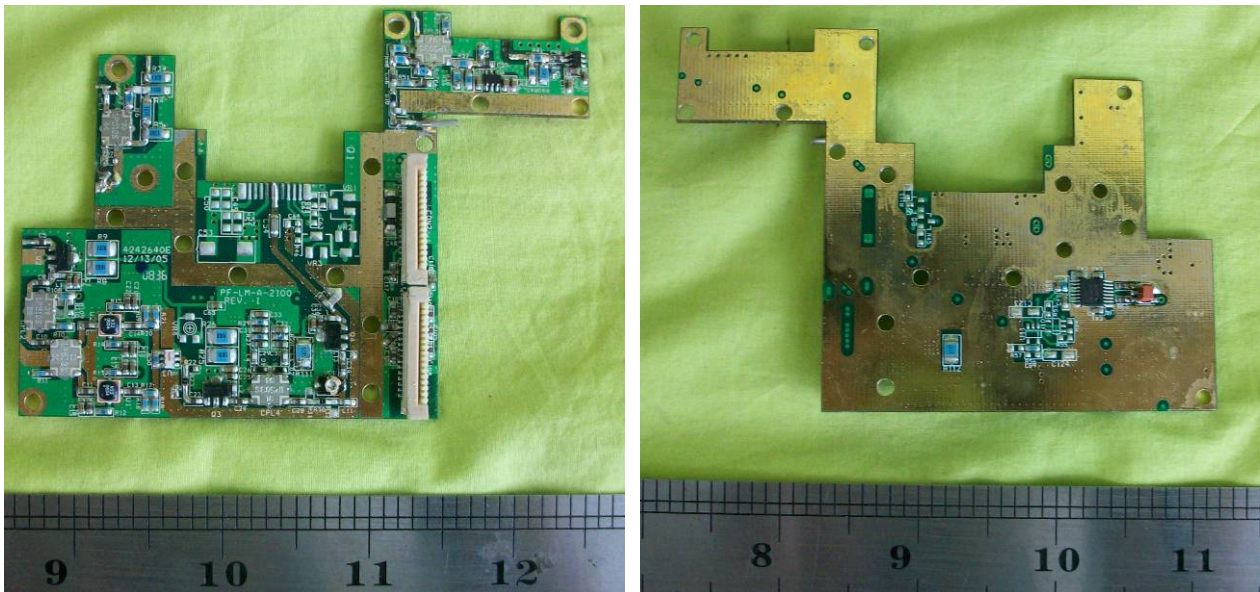

TOP & BOTTOM VIEW OF PART (MODULE\_2\_1) OF MODULE\_2

----- End of report -----