



# EMI TEST REPORT

Test Report No. : 11145757H-C

**Applicant** : Mitsubishi Electric Corporation Himeji Works  
**Type of Equipment** : Smart Keyless System (Smart Unit)  
**Model No.** : SKEA7D-01  
**FCC ID** : WAZSKEA7D01  
**Test regulation** : FCC Part 15 Subpart B: 2016  
**Test Result** : Complied

1. This test report shall not be reproduced in full or partial, without the written approval of UL Japan, Inc.
2. The results in this report apply only to the sample tested.
3. This sample tested is in compliance with the limits of the above regulation.
4. The test results in this test report are traceable to the national or international standards.
5. This test report must not be used by the customer to claim product certification, approval, or endorsement by NVLAP, NIST, or any agency of the Federal Government.
6. This test report covers EMC technical requirements. It does not cover administrative issues such as Manual or non-EMC test related Requirements. (if applicable)

**Date of test:** June 12, 2016

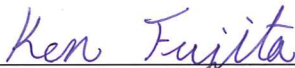
**Representative test engineer:**   
Ken Fujita  
Engineer  
Consumer Technology Division

**Approved by:**   
Motoya Imura  
Engineer  
Consumer Technology Division

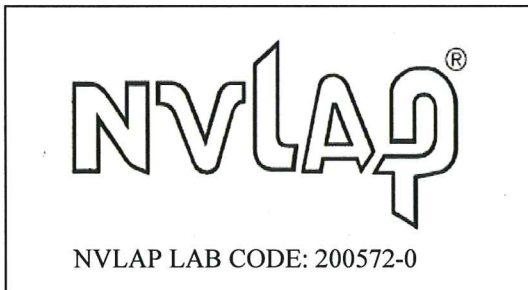

This laboratory is accredited by the NVLAP LAB CODE 200572-0, U.S.A. The tests reported herein have been performed in accordance with its terms of accreditation.  
\*As for the range of Accreditation in NVLAP, you may refer to the WEB address,  
[http://japan.ul.com/resources/emc\\_accredited/](http://japan.ul.com/resources/emc_accredited/)



<b>CONTENTS</b>	<b>PAGE</b>
<b>SECTION 1: Customer information .....</b>	<b>4</b>
<b>SECTION 2: Equipment under test (E.U.T.) .....</b>	<b>4</b>
<b>SECTION 3: Test specification, procedures &amp; results .....</b>	<b>5</b>
<b>SECTION 4: Operation of E.U.T. during testing .....</b>	<b>7</b>
<b>SECTION 5: Radiated Emission .....</b>	<b>8</b>
<b>APPENDIX 1: Test data .....</b>	<b>9</b>
<b>Radiated Emission .....</b>	<b>9</b>
<b>APPENDIX 2: Test instruments .....</b>	<b>11</b>
<b>APPENDIX 3: Photographs of test setup.....</b>	<b>12</b>
<b>Radiated Emission .....</b>	<b>12</b>
<b>Worst Case Position (Horizontal: X-axis/ Vertical:Y-axis) .....</b>	<b>13</b>

## **SECTION 1: Customer information**

Company Name : Mitsubishi Electric Corporation Himeji works  
Address : 840 Chiyoda-machi Himeji Hyogo, 670-8677, Japan  
Telephone Number : +81-79-298-7363  
Facsimile Number : +81-79-298-9929  
Contact Person : Shinichi Furuta

## **SECTION 2: Equipment under test (E.U.T.)**

### **2.1 Identification of E.U.T.**

Type of Equipment : Smart Keyless System (Smart Unit)  
Model No. : SKEA7D-01  
Serial No. : Refer to Section 4, Clause 4.2  
Rating : DC 12.0 V  
Receipt Date of Sample : May 12, 2016  
Country of Mass-production : Thailand  
Condition of EUT : Production prototype  
(Not for Sale: This sample is equivalent to mass-produced items.)  
Modification of EUT : No Modification by the test lab

### **2.2 Product Description**

Model No: SKEA7D-01 (referred to as the EUT in this report) is the Smart Keyless System (Smart Unit).  
The clock frequency of EUT is 8 MHz (CPU) and 30.32 MHz (RF IC).

### **Radio Specification**

#### **LF Part \***

Equipment Type : Transmitter  
Type of modulation : ASK  
Bandwidth : 2.5 kHz  
Frequency of operation : 125 kHz  
Other clock frequency : 30.32 MHz  
Antenna Type : Inductive  
Method of Frequency Generation : Crystal  
Operating voltage (inner) : DC +12.0V

#### **RF Part**

Type of Receiver : Receiver  
Frequency of operation : 315 MHz  
Other clock frequency : 8 MHz  
Intermediate frequency : 200 kHz  
Antenna Type : Bar Antenna  
Method of Frequency Generation : Crystal  
Operating voltage (inner) : DC +5.0V

\* The test of transmitter part was performed separately from this test report, and the conformability is confirmed.  
LF Part test report No. 11145757H-A (FCC15C).

---

**UL Japan, Inc.**

**Ise EMC Lab.**

4383-326 Asama-cho, Ise-shi, Mie-ken 516-0021 JAPAN

Telephone : +81 596 24 8999

Facsimile : +81 596 24 8124

## SECTION 3: Test specification, procedures & results

### 3.1 Test specification

Test specification : FCC Part 15 Subpart B  
FCC part 15 final revised on April 6, 2016.

Title : FCC 47CFR Part15 Radio Frequency Device  
Subpart B Unintentional Radiators

### 3.2 Procedures and results

Item	Test Procedure	Limits	Deviation	Worst margin	Result
Conducted emission	FCC: ANSI C63.4: 2014 7. AC power - line conducted emission measurements	FCC:Part 15 Subpart B 15.107(a)	N/A	N/A	N/A *1)
	IC: RSS-Gen 8.8	IC: RSS-Gen 8.8			
Radiated emission	FCC: ANSI C63.4: 2014 8. Radiated emission measurements	FCC: Part 15 Subpart B 15.109(a)	N/A	13.8 dB 98.925 MHz Vertical, QP	Complied
	IC: RSS-Gen 7	IC: RSS-Gen 7.1.2			

\*Note: UL Japan, Inc's EMI Work Procedure 13-EM-W0420.

\*1) The test is not applicable since the EUT is not the device that is designed to be connected to the public utility (AC) power line.

### 3.3 Addition to standard

No addition, exclusion nor deviation has been made from the standard.

### 3.4 Uncertainty

#### EMI

The following uncertainties have been calculated to provide a confidence level of 95 % using a coverage factor  $k = 2$ .

Polarity	Radiated emission (Below 1GHz)			
	(3 m*)(+dB)		(10 m*)(+dB)	
	30 – 200 MHz	200 – 1000MHz	30 – 200 MHz	200 – 1000MHz
Horizontal	4.9 dB	5.2 dB	4.9 dB	5.0 dB
Vertical	4.6 dB	5.9 dB	5.0 dB	5.0 dB

Radiated emission				
(3 m*)(+dB)		(1 m*)(+dB)		(10 m*)(+dB)
1 – 6GHz	6 – 18GHz	10 – 26.5 GHz	26.5 – 40GHz	1 -18 GHz
5.1 dB	5.3 dB	5.1 dB	5.1 dB	5.3 dB

\* Measurement distance

#### Radiated emission test(3m)

The data listed in this test report has enough margin, more than the site margin.

**UL Japan, Inc.**

**Ise EMC Lab.**

4383-326 Asama-cho, Ise-shi, Mie-ken 516-0021 JAPAN

Telephone : +81 596 24 8999

Facsimile : +81 596 24 8124

### 3.5 Test Location

UL Japan, Inc. Ise EMC Lab. \*NVLAP Lab. code: 200572-0  
4383-326 Asama-cho, Ise-shi, Mie-ken 516-0021 JAPAN  
Telephone : +81 596 24 8999 Facsimile : +81 596 24 8124

	IC Registration Number	Width x Depth x Height (m)	Size of reference ground plane (m) / horizontal conducting plane	Other rooms
No.1 semi-anechoic chamber	2973C-1	19.2 x 11.2 x 7.7m	7.0 x 6.0m	No.1 Power source room
No.2 semi-anechoic chamber	2973C-2	7.5 x 5.8 x 5.2m	4.0 x 4.0m	-
No.3 semi-anechoic chamber	2973C-3	12.0 x 8.5 x 5.9m	6.8 x 5.75m	No.3 Preparation room
No.3 shielded room	-	4.0 x 6.0 x 2.7m	N/A	-
No.4 semi-anechoic chamber	2973C-4	12.0 x 8.5 x 5.9m	6.8 x 5.75m	No.4 Preparation room
No.4 shielded room	-	4.0 x 6.0 x 2.7m	N/A	-
No.5 semi-anechoic chamber	-	6.0 x 6.0 x 3.9m	6.0 x 6.0m	-
No.6 shielded room	-	4.0 x 4.5 x 2.7m	4.0 x 4.5 m	-
No.6 measurement room	-	4.75 x 5.4 x 3.0m	4.75 x 4.15 m	-
No.7 shielded room	-	4.7 x 7.5 x 2.7m	4.7 x 7.5m	-
No.8 measurement room	-	3.1 x 5.0 x 2.7m	N/A	-
No.9 measurement room	-	8.8 x 4.6 x 2.8m	2.4 x 2.4m	-
No.11 measurement room	-	6.2 x 4.7 x 3.0m	4.8 x 4.6m	-

\* Size of vertical conducting plane (for Conducted Emission test): 2.0 x 2.0 m for No.1, No.2, No.3, and No.4 semi-anechoic chambers and No.3 and No.4 shielded rooms.

### 3.6 Test data, Test instruments, and Test set up

Refer to APPENDIX.

## **SECTION 4: Operation of E.U.T. during testing**

### **4.1 Operating modes**

The mode is used : Receiving mode (315MHz)

\* It was confirmed by using checker that the EUT receives the signal from the transmitter (pair of EUT).

### **4.2 Configuration and peripherals**

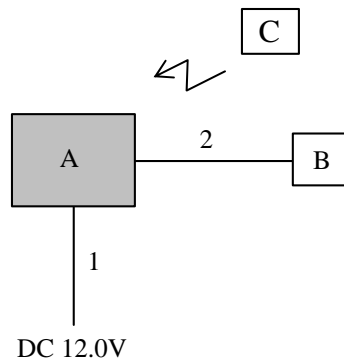

\*Cabling and setup were taken into consideration and test data was taken under worse case conditions.

#### **Description of EUT and Support equipment**

No.	Item	Model number	Serial number	Manufacturer	Remark
A	Smart Keyless System (Smart Unit)	SKEA7D-01	20160609-E1(No.14)	Mitsubishi Electric Corporation Himeji works	EUT
B	Switch Box 2	-	No.23	Mitsubishi Electric Corporation Himeji works	(No.2)
C	Smart Keyless System (Hand Unit)	SKEA7D-02	20160609-T1 (No.17)	Mitsubishi Electric Corporation Himeji works	-

#### **List of cables used**

No.	Name	Length (m)	Shield		Remarks
			Cable	Connector	
1	DC Cable	1.4	Unshielded	Unshielded	-
2	Signal Cable	0.9	Unshielded	Unshielded	-

**UL Japan, Inc.**

**Ise EMC Lab.**

4383-326 Asama-cho, Ise-shi, Mie-ken 516-0021 JAPAN

Telephone : +81 596 24 8999

Facsimile : +81 596 24 8124

## **SECTION 5: Radiated Emission**

### **5.1 Operating environment**

Test place : No.2 semi anechoic chamber  
Temperature : See data  
Humidity : See data

### **5.2 Test configuration**

EUT was placed on a urethane platform of nominal size, 1.0 m by 1.5 m, raised 0.8 m above the conducting ground plane.

The EUT was set on the edge of the tabletop.

Test was made with the antenna positioned in both the horizontal and vertical planes of polarization. The measurement antenna was varied in height above the conducting ground plane to obtain the maximum signal strength.

Photographs of the set up are shown in Appendix 3.

### **5.3 Test conditions**

Frequency range : 30 MHz - 200 MHz (Biconical antenna) / 200 MHz - 1000 MHz (Logperiodic antenna)  
Test distance : 3 m  
EUT position : Table top  
EUT operation mode : See Clause 4.1

### **5.4 Test procedure**

The height of the measuring antenna varied between 1 and 4 m and EUT was rotated a full revolution in order to obtain the maximum value of the electric field intensity.

The measurements were performed for both vertical and horizontal antenna polarization with the Test Receiver.

The radiated emission measurements were made with the following detector function of the Test Receiver.

Frequency	Below 1 GHz
Instrument used	Test Receiver
IF Bandwidth	QP: BW 120 kHz

- The carrier level and noise levels were confirmed at each position of X, Y and Z axes of EUT to see the position of maximum noise, and the test was made at the position that has the maximum noise.

### **5.5 Test result**

Summary of the test results: Pass

Date: June 12, 2016

Test engineer: Ken Fujita

---

**UL Japan, Inc.**

**Ise EMC Lab.**

4383-326 Asama-cho, Ise-shi, Mie-ken 516-0021 JAPAN

Telephone : +81 596 24 8999

Facsimile : +81 596 24 8124



**APPENDIX 1: Test data**

**Radiated Emission**  
(Below 1 GHz)

**DATA OF RADIATED EMISSION TEST**

UL Japan, Inc. Ise EMC Lab. No.2 Semi Anechoic Chamber  
Date : 2016/06/12

Report No. : 11145757H  
Temp./Humi. : 23deg. C / 65% RH  
Engineer : Ken Fujita

Mode / Remarks : Kx 315MHz Worst-Axis(Hori:X / Vert:Y)

LIMIT : FCC15.109(a) 3m, below 1GHz:QP, above 1GHz:AV  
All other spurious emissions were less than 20dB for the limit.

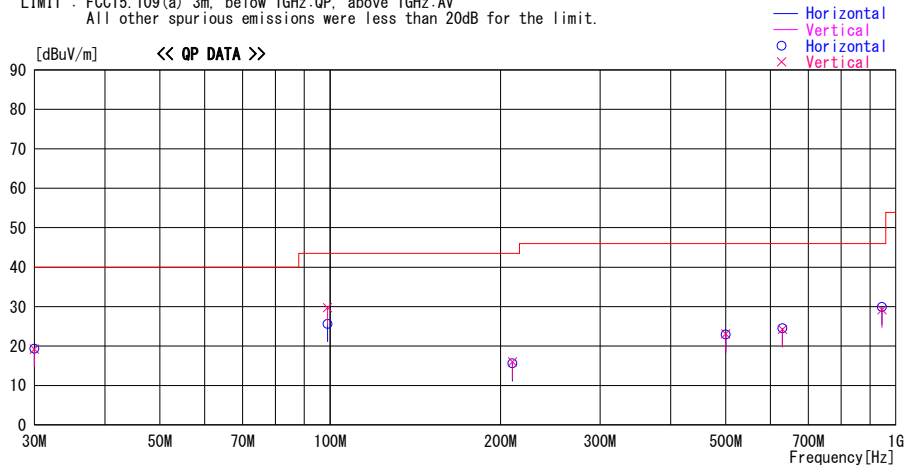

Frequency [MHz]	Reading [dBuV]	DET	Antenna	Loss&	Level	Angle	Height	Polar.	Limit	Margin	Comment
			Factor [dB/m]	Gain [dB]							
30.000	24.2	QP	16.8	-21.8	19.2	80	200	Vert.	40.0	20.8	
30.000	24.3	QP	16.8	-21.8	19.3	0	100	Hori.	40.0	20.7	
98.925	40.9	QP	9.6	-20.8	29.7	23	314	Vert.	43.5	13.8	
98.925	36.8	QP	9.6	-20.8	25.6	10	385	Hori.	43.5	17.9	
210.000	23.3	QP	11.7	-19.4	15.6	0	200	Hori.	43.5	27.9	
210.000	23.7	QP	11.7	-19.4	16.0	359	200	Vert.	43.5	27.5	
500.000	24.3	QP	17.5	-18.9	22.9	0	200	Hori.	46.0	23.1	
500.000	24.5	QP	17.5	-18.9	23.1	0	200	Vert.	46.0	22.9	
630.000	23.2	QP	19.1	-18.1	24.2	0	100	Vert.	46.0	21.8	
630.000	23.5	QP	19.1	-18.1	24.5	285	200	Hori.	46.0	21.5	
945.000	23.0	QP	22.1	-15.9	29.2	33	200	Vert.	46.0	16.8	
945.000	23.7	QP	22.1	-15.9	29.9	0	200	Hori.	46.0	16.1	

CHART:WITH FACTOR ANT TYPE: -30MHz:LOOP, 30-200MHz:BICONICAL, 200MHz-1000MHz:LOGPERIODIC, 1000MHz--:HORN  
CALCULATION : RESULT = READING + ANT FACTOR + LOSS & GAIN(CABLE - GAIN(AMP))

\*The limit is rounded down to one decimal place.

\*The test result is rounded off to one or two decimal places, so some differences might be observed.

**UL Japan, Inc.**  
**Ise EMC Lab.**

4383-326 Asama-cho, Ise-shi, Mie-ken 516-0021 JAPAN  
Telephone : +81 596 24 8999  
Facsimile : +81 596 24 8124

**Radiated Emission**  
(Above 1 GHz)

**DATA OF RADIATED EMISSION TEST**

UL Japan, Inc. Ise EMC Lab. No.2 Semi Anechoic Chamber  
Date : 2016/06/12

Report No. : 11145757H  
Temp./Humi. : 23deg. C / 65% RH  
Engineer : Ken Fujita

Mode / Remarks : Rx 315MHz Worst-Axis(Hori:X / Vert:Y)

LIMIT : FCC15.109(a) 3m, below 1GHz:QP, above 1GHz:PK  
FCC15.109(a) 3m, below 1GHz:QP, above 1GHz:AV

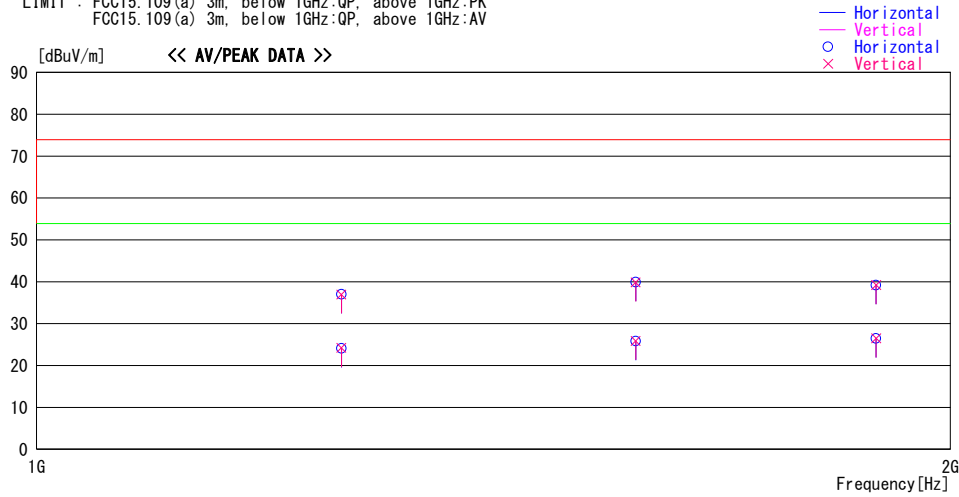

Frequency [MHz]	Reading [dBuV]	DET	Antenna	Loss&	Level [dBuV/m]	Angle [Deg]	Height [cm]	Polar.	Limit [dBuV/m]	Margin [dB]	Comment
			Factor [dB/m]	Gain [dB]							
1260.000	45.7	PK	25.2	-33.9	37.0	0	100	Hori.	73.9	36.9	
1260.000	45.7	PK	25.2	-33.9	37.0	0	100	Vert.	73.9	36.9	
1260.000	32.8	AV	25.2	-33.9	24.1	0	100	Hori.	53.9	29.8	
1260.000	32.9	AV	25.2	-33.9	24.2	0	100	Vert.	53.9	29.7	
1575.000	47.4	PK	25.8	-33.3	39.9	0	100	Hori.	73.9	34.0	
1575.000	47.4	PK	25.8	-33.3	39.9	0	100	Vert.	73.9	34.0	
1575.000	33.3	AV	25.8	-33.3	25.8	0	100	Hori.	53.9	28.1	
1575.000	33.4	AV	25.8	-33.3	25.9	0	100	Vert.	53.9	28.0	
1890.000	45.2	PK	26.9	-32.9	39.2	0	100	Vert.	73.9	34.7	
1890.000	45.2	PK	26.9	-32.9	39.2	0	100	Hori.	73.9	34.7	
1890.000	32.5	AV	26.9	-32.9	26.5	0	100	Vert.	53.9	27.4	
1890.000	32.5	AV	26.9	-32.9	26.5	0	100	Hori.	53.9	27.4	

CHART:WITH FACTOR ANT TYPE: -30MHz:LOOP, 30-200MHz:BICONICAL, 200MHz-1000MHz:LOGPERIODIC, 1000MHz--HORN  
CALCULATION : RESULT = READING + ANT FACTOR + LOSS & GAIN(CABLE - GAIN(AMP))

\*The limit is rounded down to one decimal place.

\*The test result is rounded off to one or two decimal places, so some differences might be observed.

## **APPENDIX 2: Test instruments**

### **EMI test equipment**

Control No.	Instrument	Manufacturer	Model No	Serial No	Test Item	Calibration Date * Interval(month)
MAEC-02	Semi Anechoic Chamber(NSA)	TDK	Semi Anechoic Chamber 3m	DA-06902	RE	2015/07/01 * 12
MOS-22	Thermo-Hygrometer	Custom	CTH-201	0003	RE	2016/01/21 * 12
MJM-14	Measure	KOMELON	KMC-36	-	RE	-
COTS-MEMI	EMI measurement program	TSJ	TEPTO-DV	-	RE	-
MSA-10	Spectrum Analyzer	Agilent	E4448A	MY46180655	RE	2016/02/24 * 12
MTR-03	Test Receiver	Rohde & Schwarz	ESCI	100300	RE	2015/10/11 * 12
MBA-03	Biconical Antenna	Schwarzbeck	BBA9106	1915	RE	2015/10/11 * 12
MLA-21	Logperiodic Antenna(200-1000MHz)	Schwarzbeck	VUSLP9111B	911B-190	RE	2016/01/30 * 12
MCC-12	Coaxial Cable	Fujikura/Agilent	-	-	RE	2016/02/08 * 12
MAT-07	Attenuator(6dB)	Weinschel Corp	2	BK7970	RE	2015/11/10 * 12
MPA-09	Pre Amplifier	Agilent	8447D	2944A10845	RE	2015/09/04 * 12
MMM-01	Digital Tester	Fluke	FLUKE 26-3	78030611	RE	2015/08/19 * 12
MHA-06	Horn Antenna 1-18GHz	Schwarzbeck	BBHA9120D	254	RE	2016/02/29 * 12
MCC-168	Microwave Cable	Junkosha	MWX221	1408S016(1m) / 1409S492(5m)	RE	2015/09/24 * 12
MPA-10	Pre Amplifier	Agilent	8449B	3008A02142	RE	2016/01/19 * 12
MTR-09	EMI Test Receiver	Rohde & Schwarz	ESU26	100412	RE	2015/06/08 * 12

**The expiration date of the calibration is the end of the expired month.**

**All equipment is calibrated with valid calibrations. Each measurement data is traceable to the national or international standards.**

**As for some calibrations performed after the tested dates, those test equipment have been controlled by means of an unbroken chains of calibrations.**

**Test Item:**

**RE: Radiated emission**

**UL Japan, Inc.**

**Ise EMC Lab.**

4383-326 Asama-cho, Ise-shi, Mie-ken 516-0021 JAPAN

Telephone : +81 596 24 8999

Facsimile : +81 596 24 8124