

# Global EMC Inc. Labs EMC & RF Test Report

As per

**RSS 210 Issue 7:2007**

**&**

**FCC Part 15 Subpart C:2008**

**Unlicensed Intentional Radiators**

on the

**CY3271 FirstTouch RF Bridge**

**(PDCR-9439)**

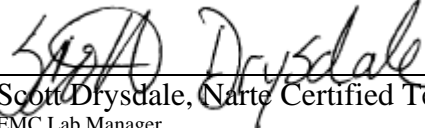
  
Scott Drysdale, Narte Certified Technician  
EMC Lab Manager  
Global EMC Inc.  
180 Brodie Dr, Unit 2  
Richmond Hill, ON L4B 3K8  
Canada  
Ph: (905) 883-3919

Testing produced for



See Appendix A for full customer & EUT details.



Client	Cypress	
Product	CY3271 FirstTouch RF Bridge	
Standard(s)	RSS 210 Issue 7:2007 / FCC Part 15 Subpart C 15:2008	

## Table of Contents

Table of Contents .....	2
Report Scope .....	3
Summary .....	4
Test Results Summary .....	5
Justifications, Descriptions, or Deviations.....	6
Applicable Standards, Specifications and Methods.....	7
Sample calculation(s).....	8
Document Revision Status.....	8
Definitions and Acronyms .....	9
Testing Facility .....	10
Calibrations and Accreditations .....	10
Testing Environmental Conditions and Dates .....	11
Detailed Test Results Section .....	12
Power Line Conducted Emissions .....	13
Spurious Radiated Emissions.....	19
6dB Bandwidth of Digitally Modulated Systems .....	32
Maximum Peak Envelope Conducted Power .....	38
Spurious Conducted Emissions.....	41
Maximum Permissible Exposure .....	51
Appendix A – EUT Summary.....	53
Appendix B – EUT and Test Setup Photographs.....	54

Client	Cypress	
Product	CY3271 FirstTouch RF Bridge	
Standard(s)	RSS 210 Issue 7:2007 / FCC Part 15 Subpart C 15:2008	

## Report Scope

This report addresses the EMC verification testing and test results of the CY3271 FirstTouch RF Bridge, herein referred to as EUT (Equipment Under Test) performed at Global EMC Labs.

The EUT was tested for compliance against the following standards:

RSS 210 Issue 7:2007 / FCC Part 15 Subpart C 15:2008

Test procedures, results, justifications, and engineering considerations, if any, follow later in this report.

The results contained in this report relate only to the item(s) tested.

This report does not imply product endorsement by A2LA or any other accreditation agency, any government, or Global EMC Inc.

Opinions/interpretations expressed in this report, if any, are outside the scope of Global EMC Inc accreditation. Any opinions expressed do not necessarily reflect the opinions of Global EMC Inc, unless otherwise stated.

Client	<b>Cypress</b>	
Product	CY3271 FirstTouch RF Bridge	
Standard(s)	RSS 210 Issue 7:2007 / FCC Part 15 Subpart C 15:2008	

## Summary

The results contained in this report relate only to the item(s) tested.

EUT FCC Certification #, FCC ID:	WAP-CFYI3271
EUT Industry Canada Certification #, IC:	TBA
EUT Passed all tests performed.	Yes (see test results summary)
Tests conducted by	Scott Drysdale

Client	<b>Cypress</b>	
Product	CY3271 FirstTouch RF Bridge	
Standard(s)	RSS 210 Issue 7:2007 / FCC Part 15 Subpart C 15:2008	

## Test Results Summary

Standard/Method	Description	Class/Limit	Result
FCC 15.203	Antenna Requirement	Unique	Pass See Justification
FCC 15.205 RSS 210 (Table 1)	Restricted Bands for intentional operation	No Transmit	Pass See Justification
FCC 15.207	Power line conducted emissions	QuasiPeak Average	Pass
FCC 15.209 RSS-210 (Table 2)	Spurious Radiated emissions	QuasiPeak Average	Pass
FCC 15.247(a)2 RSS-210 A8.2(a)	6 dB Bandwidth	> 500 kHz	Pass
FCC 15.247(b)2 RSS-210 A8.4(4)	Max output power	< 1 Watt	Pass
FCC 15.247(b)(4) RSS-210 A8.4(5)	Antenna Gain	< 6 dBi	Pass See Justifications
FCC 15.247(d) RSS-210 A8.5	Antenna conducted spurious	< 20 dBc	Pass
FCC 15.247(e) RSS-210 A8.2(b)	Spectral Density	< 8 dBm (3 kHz BW)	Pass
FCC 15.247(i) IC Safety code 6	Maximum Permissible Exposure	> 20 cm separation.	Pass See justification and calculations
<b>Overall Result</b>			<b>PASS</b>

Client	Cypress	
Product	CY3271 FirstTouch RF Bridge	
Standard(s)	RSS 210 Issue 7:2007 / FCC Part 15 Subpart C 15:2008	

All tests were performed by Scott Drysdale.

If the product as tested or otherwise complies with the specification, the EUT is deemed to comply with the requirement and is deemed a 'PASS' grade. If not 'FAIL' grade will be issued. Note that 'PASS' / 'FAIL' grade is independent of any measurement uncertainties. A 'PASS' / 'FAIL' grade within measurement uncertainty is marked with a '\*'.

### ***Justifications, Descriptions, or Deviations***

The following justifications for tests not performed or deviations from the above listed specifications apply:

For the Antenna requirement specified in FCC 15.203 (RSS 210 section 5.5),

For the Restricted Bands of operation, the EUT is designed to only operate between 2412 to 2460 MHz.

For the power line conducted emissions requirements, the EUT is DC powered, and this test does not apply.

For the Antenna gain, the antenna is designed to have less than 6 dBi.

For maximum permissible exposure, this device operates at less than 1 Watt at 2412 to 2460 MHz and is designed to operate greater than 20 cm from personnel during normal operation. No testing is required, however worst case calculated exposure compliance follows later in this report.

Client	Cypress	
Product	CY3271 FirstTouch RF Bridge	
Standard(s)	RSS 210 Issue 7:2007 / FCC Part 15 Subpart C 15:2008	

### ***Applicable Standards, Specifications and Methods***

- ANSI C63.4:2003 - Methods of Measurement of Radio-Noise Emissions from Low-Voltage Electrical and Electronic Equipment in the Range of 9 kHz to 40 GHz
- CFR 47 FCC 15 - Code of Federal Regulations – Radio Frequency Devices
- CISPR 22:1997 - Information technology equipment – Radio disturbance characteristics – Limits and methods of measurement
- ICES-003:2004 - Digital Apparatus - Spectrum Management and Telecommunications Policy Interference-Causing Equipment Standard
- ISO 17025:2005 - General Requirements for the competence of testing and calibration laboratories
- RSS 210:2007 - Issue 7: Spectrum Management and Telecommunications Policy. Radio Standards Specification Low Power Licence-Exempt Radiocommunication Devices

Client	Cypress	
Product	CY3271 FirstTouch RF Bridge	
Standard(s)	RSS 210 Issue 7:2007 / FCC Part 15 Subpart C 15:2008	

### ***Sample calculation(s)***

Margin = limit – (received signal + antenna factor + cable loss – pre-amp gain)

Margin = 50.5dBuV/m – (50dBuV + 10dB + 2.5dB – 20dB)

Margin = 8.5 dB

### ***Document Revision Status***

Revision 1 - September 9, 2008

Revision 2 - September 24, 2009  
 Added power line conducted emissions as per TCB request.



Client	<b>Cypress</b>	
Product	CY3271 FirstTouch RF Bridge	
Standard(s)	RSS 210 Issue 7:2007 / FCC Part 15 Subpart C 15:2008	

## Definitions and Acronyms

The following definitions and acronyms are applicable in this report.  
See also ANSI C63.14.

**AE** – Auxillary Equipment.

**BW** – Bandwidth. Unless otherwise stated, this refers to the 6 dB bandwidth.

**EMC** – Electro-Magnetic Compatibility

**EMI** – Electro-Magnetic Immunity

**EUT** – Equipment Under Test

**ITE** – Information Technology Equipment with a primary function(s) of entry, storage, display, retrieval, transmission, processing, switching, or control, of data.

**LISN** – Line impedance stabilization network

**NCR** – No Calibration Required

**RF** – Radio Frequency

Client	Cypress	
Product	CY3271 FirstTouch RF Bridge	
Standard(s)	RSS 210 Issue 7:2007 / FCC Part 15 Subpart C 15:2008	

## Testing Facility

Testing for EMC on the EUT was carried out at Global EMC labs in Toronto, Ontario, Canada. The testing lab consists of a 3m semi-anechoic chamber calibrated to be able to allow measurements on an EUT with a maximum width or length of up to 2m and height up to 3m. The chamber is equipped with a turn table that is capable of testing devices up to 3300lb in weight. This facility is capable of testing products that are rated for 120 Vac and 240Vac single phase, or 208 Vac 3 phase input. DC capability is also available. The chamber is equipped with an antenna mast that controls polarization and height from the control room adjoining the shielded chamber. Radiated emissions measurements are performed using a Bilog, and Horn antenna where applicable. Conducted emissions, unless otherwise stated, are performed using a LISN.

### ***Calibrations and Accreditations***

The measurement site used is registered with Federal Communications Commission (FCC) and Industry Canada (IC). This site is calibrated for Normalized Site Attenuation (NSA) using test procedures outlined in ANSI C63.4 “Methods of Measurement of Radio-Noise Emissions from Low-Voltage Electrical and Electronic Equipment in the Range of 9 kHz to 40 GHz”. The semi-anechoic chamber is lined with ferrite tiles and absorption cones to minimize any undesired reflections. All measuring equipment is calibrated on an annual or bi-annual basis as listed for each respective test.

Client	Cypress	
Product	CY3271 FirstTouch RF Bridge	
Standard(s)	RSS 210 Issue 7:2007 / FCC Part 15 Subpart C 15:2008	

### ***Testing Environmental Conditions and Dates***

Following were the environmental conditions in the facility during time of testing –

Date	Test	Init.	Temperature (°C)	Humidity (%)	Pressure (kPa)
August 22-26th, 2008	All	SD	20-25°C	30-55%	100 -103kPa

Client	<b>Cypress</b>	
Product	CY3271 FirstTouch RF Bridge	
Standard(s)	RSS 210 Issue 7:2007 / FCC Part 15 Subpart C 15:2008	

## Detailed Test Results Section

Client	Cypress	
Product	CY3271 FirstTouch RF Bridge	
Standard(s)	RSS 210 Issue 7:2007 / FCC Part 15 Subpart C 15:2008	

## **Power Line Conducted Emissions**

### **Purpose**

The purpose of this test is to ensure that the RF energy unintentionally emitted from the EUT's power line does not exceed the limits listed below as defined in the applicable test standard, as measured from a LISN. This helps protect lower frequency radio services such as AM radio, shortwave radio, amateur radio operators, maritime radio, CB radio, and so on, from unwanted interference.

### **Limits & Method**

The limits are as defined in 47 CFR FCC Part 15 Section 15.207

Method is as defined in ANSI C64:2003

Average Limits		QuasiPeak Limits	
150 kHz – 500 kHz	56 to 46 dBuV	150 kHz – 500 kHz	66 to 56 dBuV
500 kHz – 5 MHz	46 dBuV	500 kHz – 5 MHz	56 dBuV
5 MHz – 30 MHz	50 dBuV	500 kHz – 30 MHz	60 dBuV

The limit decreases linearly with the logarithm of the frequency in the range 0.15 MHz to 0.50 MHz.

Note: If the Peak or Quasi Peak detector measurements do not exceed the Average limits, then the EUT is deemed to have passed the requirements.

Both limits are applicable, and each is specified as being measured with a 9 kHz measurement bandwidth .

Client	Cypress	
Product	CY3271 FirstTouch RF Bridge	
Standard(s)	RSS 210 Issue 7:2007 / FCC Part 15 Subpart C 15:2008	

**Typical Setup Diagram**

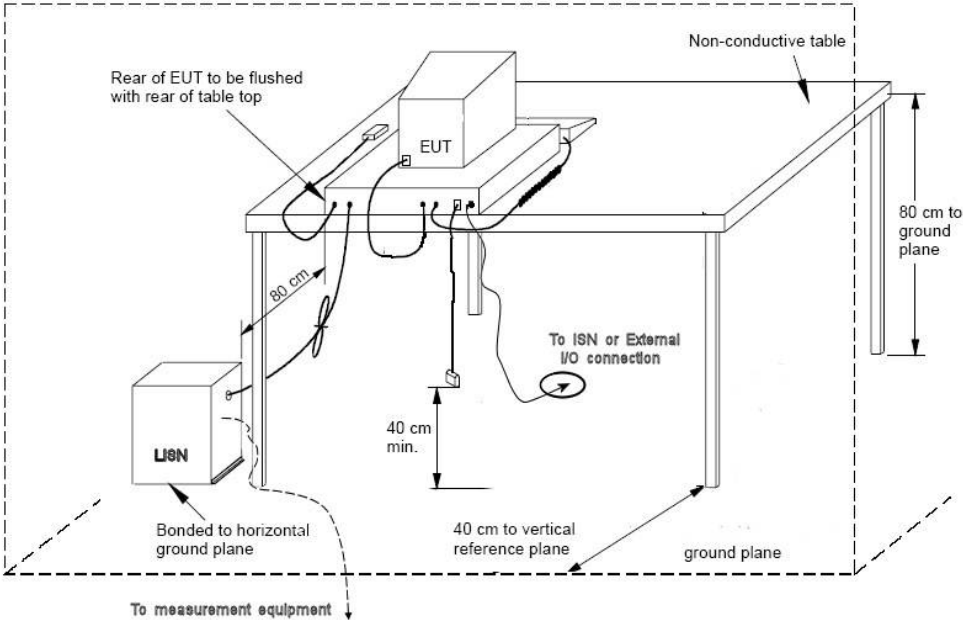

Note: The vertical reference plane is optional as per ANSI C63.4 section 5.2.2

Client	Cypress	
Product	CY3271 FirstTouch RF Bridge	
Standard(s)	RSS 210 Issue 7:2007 / FCC Part 15 Subpart C 15:2008	

### Measurement Uncertainty

The expanded measurement uncertainty is calculated in accordance with CISPR 16-4-2 and is +/-3.6 dB with a 'k=2' coverage factor and a %95 confidence level.

### Preliminary Graphs

Note the graphs shown below are for graphical illustration only. For final measurements with the appropriate detector where applicable, please refer to the table. The graph shown below is a peak measurement graph, measured with a resolution bandwidth greater then or equal to the final required detector. This graphs are performed as a worst case measurement to enable the detection of frequencies of concern and for considerable time savings.

Client	Cypress
Product	CY3271 FirstTouch RF Bridge
Standard(s)	RSS 210 Issue 7:2007 / FCC Part 15 Subpart C 15:2008



Phase (Black/Brown)

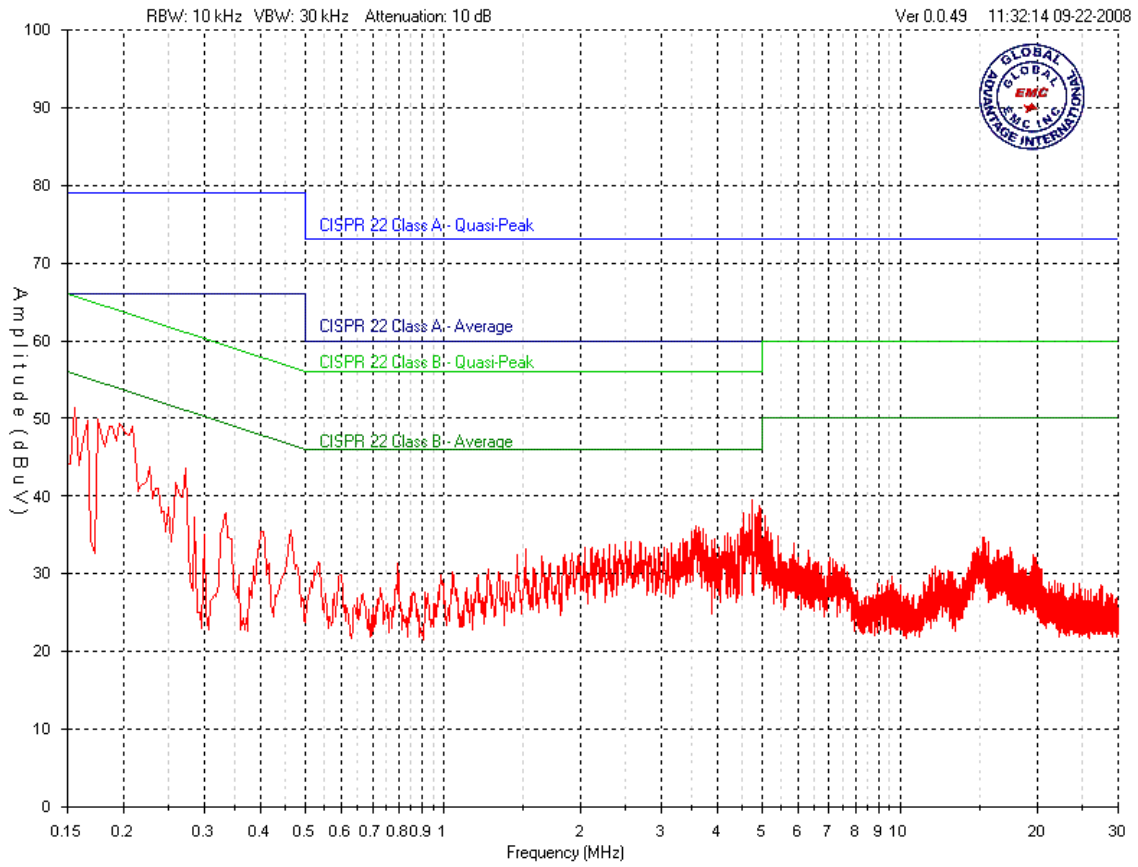



Client	Cypress
Product	CY3271 FirstTouch RF Bridge
Standard(s)	RSS 210 Issue 7:2007 / FCC Part 15 Subpart C 15:2008



Neutral (White/Blue)

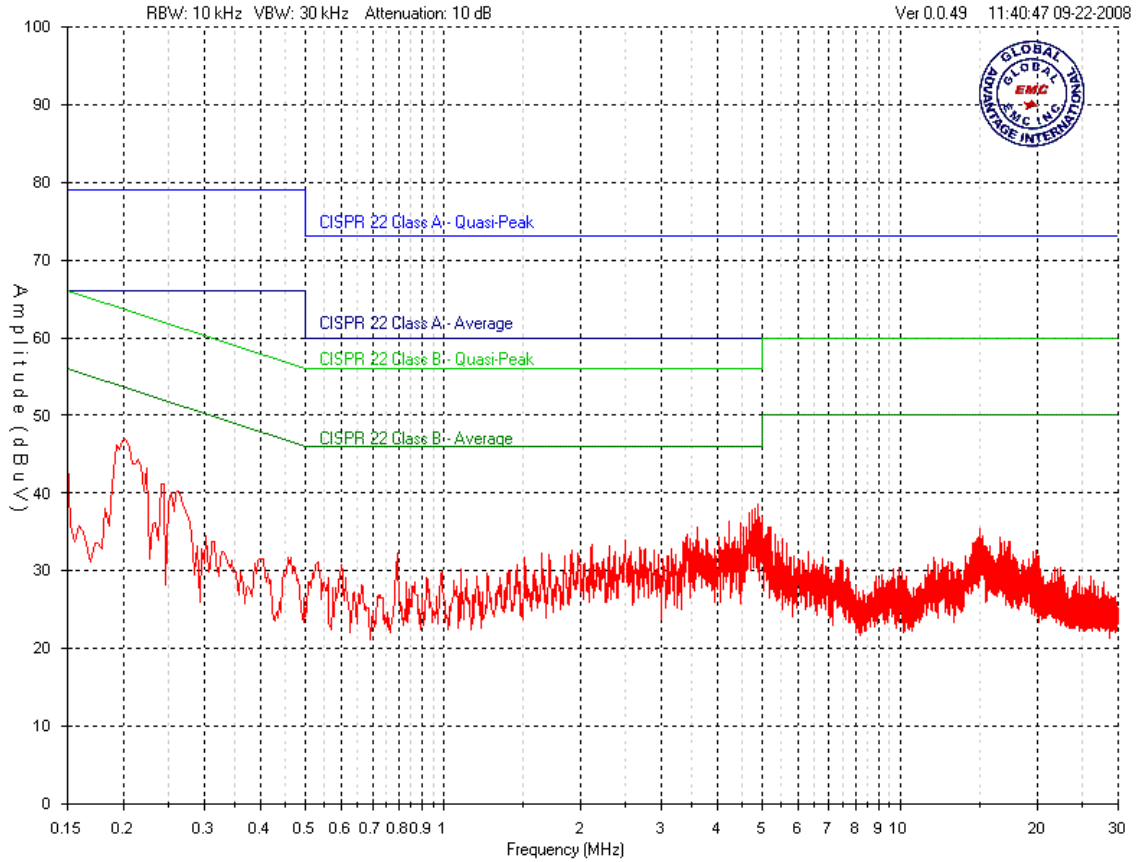

**Final Measurements**

No peak readings exceeding the average limits as shown in the graphs above, therefore no average or Quasi-Peak readings were deemed necessary for the purpose of compliance.

Note: See ‘Appendix B – EUT & Test Setup Photographs’ for photos showing the test set-up for the highest line conducted emission

Client	<b>Cypress</b>	
Product	CY3271 FirstTouch RF Bridge	
Standard(s)	RSS 210 Issue 7:2007 / FCC Part 15 Subpart C 15:2008	

## Test Equipment List

Equipment	Model No.	Manufacturer	Last calibration date	Next calibration due date	Asset #
Spectrum Analyzer	8566B	HP	2008-02-28	2010-02-28	GEMC 6
Quasi Peak Adapter	85650A	HP	2008-02-28	2010-02-28	GEMC 7
LISN	FCC-LISN-50/250-16-2-01	FCC	2007-05-02	2009-05-02	GEMC 65
RF Cable 7m	LMR-400-7M-50OHM-MN-MN	LexTec	NCR	NCR	GEMC 28
RF Cable 1m	LMR-400-1M-50OHM-MN-MN	LexTec	NCR	NCR	GEMC 29
Attenuator 10 dB	FP-50-10	Trilithic	NCR	NCR	GEMC 42

This report module is based on GEMC template "FCC – Power Line Conducted Emissions Class B\_Rev1"

Client	Cypress	
Product	CY3271 FirstTouch RF Bridge	
Standard(s)	RSS 210 Issue 7:2007 / FCC Part 15 Subpart C 15:2008	

## ***Spurious Radiated Emissions***

### **Purpose**

The purpose of this test is to ensure that the RF energy unintentionally emitted from the EUT does not exceed the limits listed below as defined in the applicable test standard, as measured from a receiving antenna. This helps protect broadcast radio services such as television, FM radio, pagers, cellular telephones, emergency services, and so on, from unwanted interference.

### **Limit(s) and Method**

The method is as defined in ANSI C63.4:2003.

The limits, as defined in 15.247(d) for unintentional radiated emissions apply for those emissions that fall in the restricted bands, as defined in Section 15.205(a). These emissions must comply with the radiated emission limits specified in Section 15.209(a).

All unintentional emissions must also meet the ‘Spurious Conducted Emissions’ requirements of -20 dBc or greater. See also ‘Spurious Conducted Emissions’ for further details.

30 MHz – 88 MHz, 100 uV/m (40.0 dBuV/m<sup>1</sup>) at 3 m  
88 MHz – 216 MHz, 150 uV/m (43.5 dBuV/m<sup>1</sup>) at 3 m  
216 MHz – 960 MHz, 200 uV/m (46.4 dBuV/m<sup>1</sup>) at 3 m  
Above 960 MHz, 500 uV/m (54.0 dBuV/m<sup>1</sup>) at 3 m  
Above 1000 MHz, 500 uV/m (54.0 dBuV/m<sup>2</sup>) at 3m

<sup>1</sup>Limit is with 120 kHz measurement bandwidth and a using a Quasi Peak detector.

<sup>2</sup>Limit is with 1 MHz measurement bandwidth and using an Average detector, scanned in accordance with 15.33 to above the 10<sup>th</sup> harmonic (25 GHz).

Client	Cypress	
Product	CY3271 FirstTouch RF Bridge	
Standard(s)	RSS 210 Issue 7:2007 / FCC Part 15 Subpart C 15:2008	

**Typical Radiated Emissions Setup**

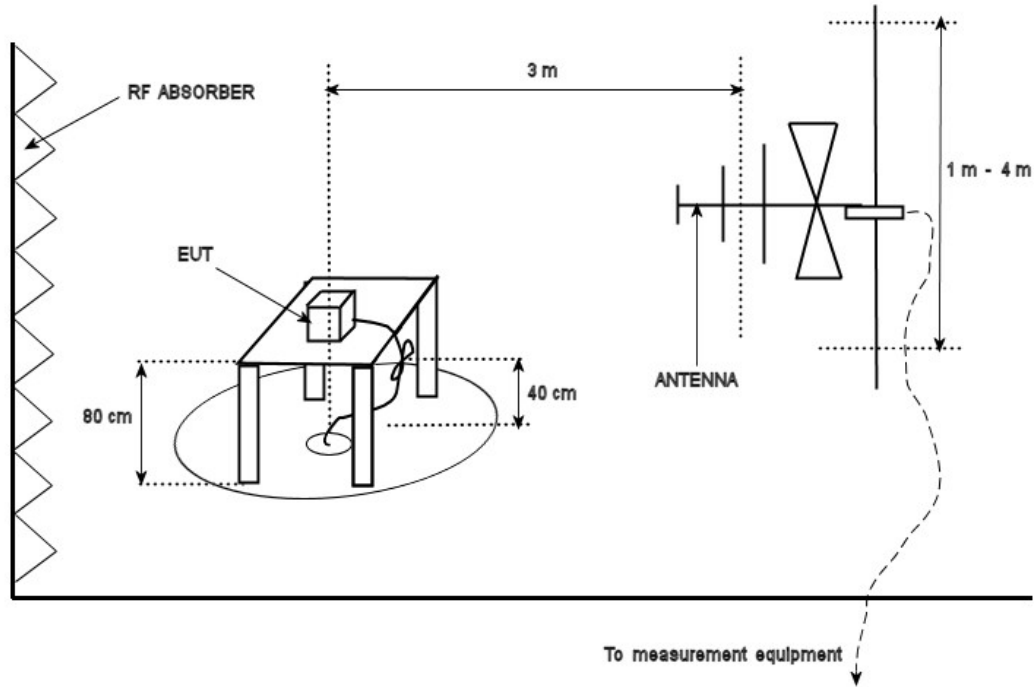

Client	Cypress	
Product	CY3271 FirstTouch RF Bridge	
Standard(s)	RSS 210 Issue 7:2007 / FCC Part 15 Subpart C 15:2008	

## Measurement Uncertainty

The expanded measurement uncertainty is calculated in accordance with CISPR 16-4-2 and is +/-4.4 dB with a 'k=2' coverage factor and a %95 confidence level.

## Preliminary Graphs

Note the graphs shown below are for graphical illustration only. For final measurements with the appropriate detector, please refer to the final measurement table where applicable. The graph shown below is a maximized peak measurement graph, measured with a resolution bandwidth greater than the final required detector and over a full 0-360 rotation. This peaking process is done as a worst case measurement. This process enables the detection of frequencies of concern for final measurement, and provides considerable time savings.

In accordance with FCC Part 15, Subpart A, Section 15.33, the device was scanned to a minimum of a 25 GHz.

Low, middle and high channel were all verified for the frequency range of 30 MHz to 2GHz and no difference was observed. The graphs shown are middle channel as worst case, however the graphs also represent low and high channel operation.

Client	Cypress
Product	CY3271 FirstTouch RF Bridge
Standard(s)	RSS 210 Issue 7:2007 / FCC Part 15 Subpart C 15:2008



Vertical – Peak Emissions Graph (Worst case channel - middle)

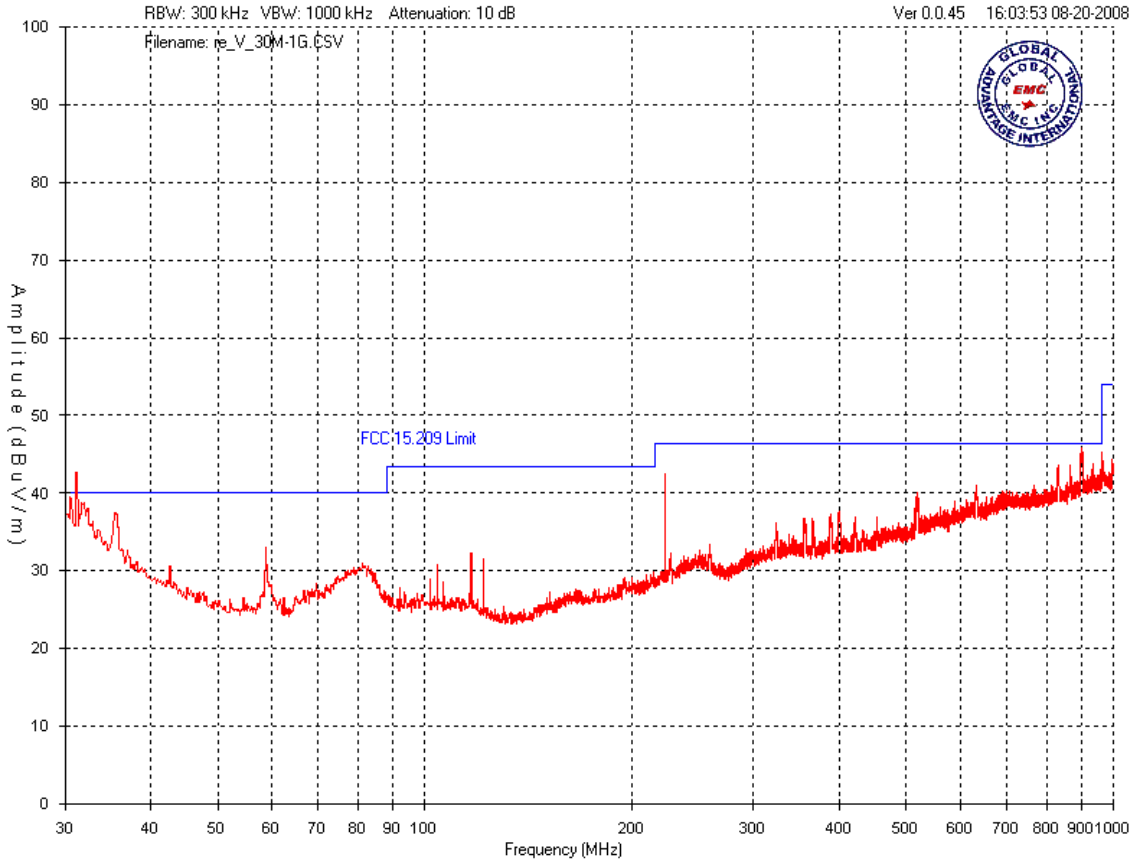

Note: No emissions were detected from 1GHz to 1.5GHz

Client	Cypress
Product	CY3271 FirstTouch RF Bridge
Standard(s)	RSS 210 Issue 7:2007 / FCC Part 15 Subpart C 15:2008



Horizontal – Peak Emissions Graph – (Worst case channel – middle)

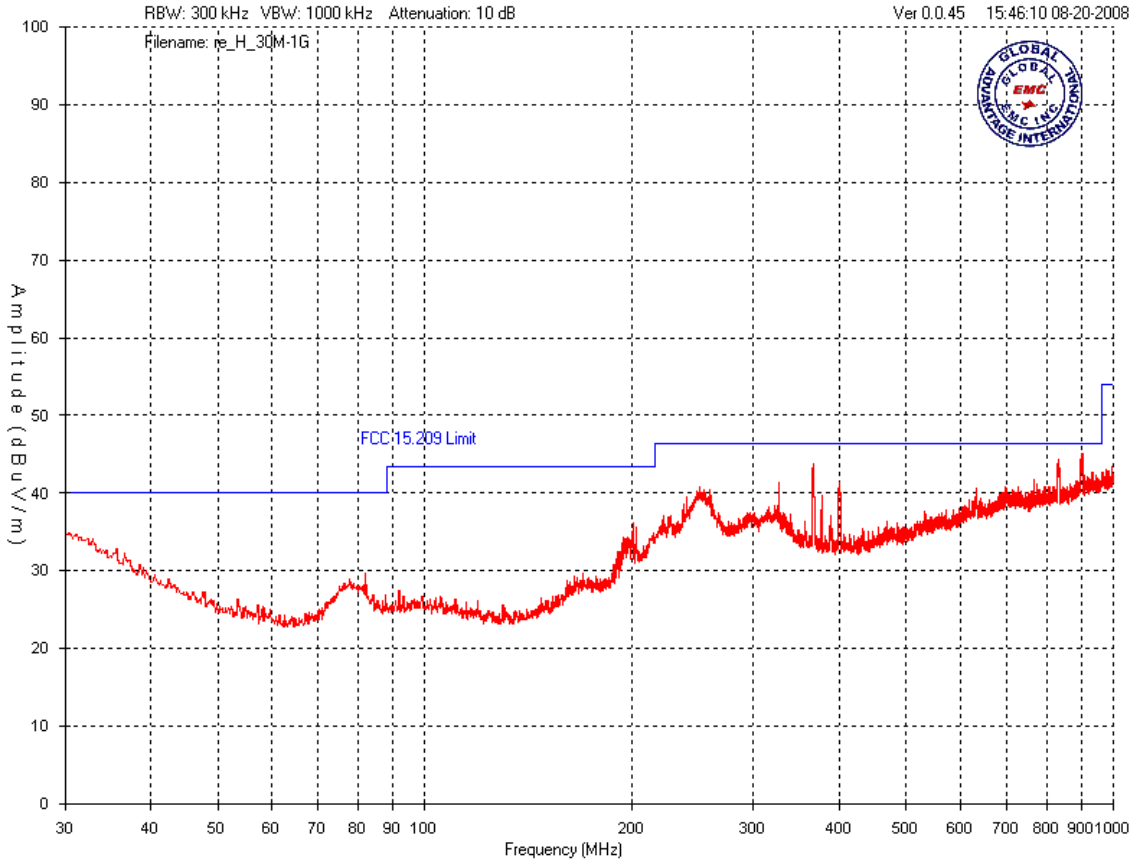

Note: No emissions were detected from 1GHz to 1.5GHz

Client	Cypress	
Product	CY3271 FirstTouch RF Bridge	
Standard(s)	RSS 210 Issue 7:2007 / FCC Part 15 Subpart C 15:2008	

Vertical 1.5 GHz to 5 GHz (Worst case - low channel)

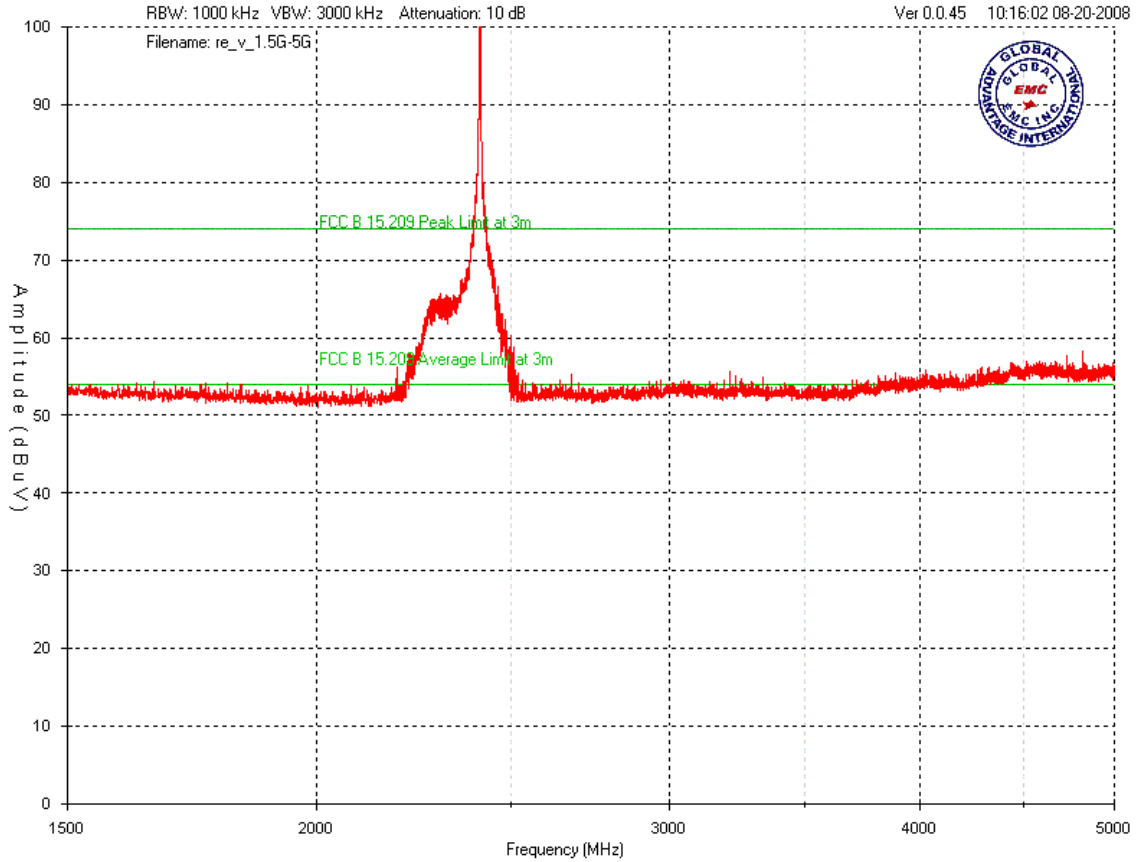



Client	Cypress	
Product	CY3271 FirstTouch RF Bridge	
Standard(s)	RSS 210 Issue 7:2007 / FCC Part 15 Subpart C 15:2008	

Horizontal 1.5 GHz to 5 GHz (worst case – low channel)

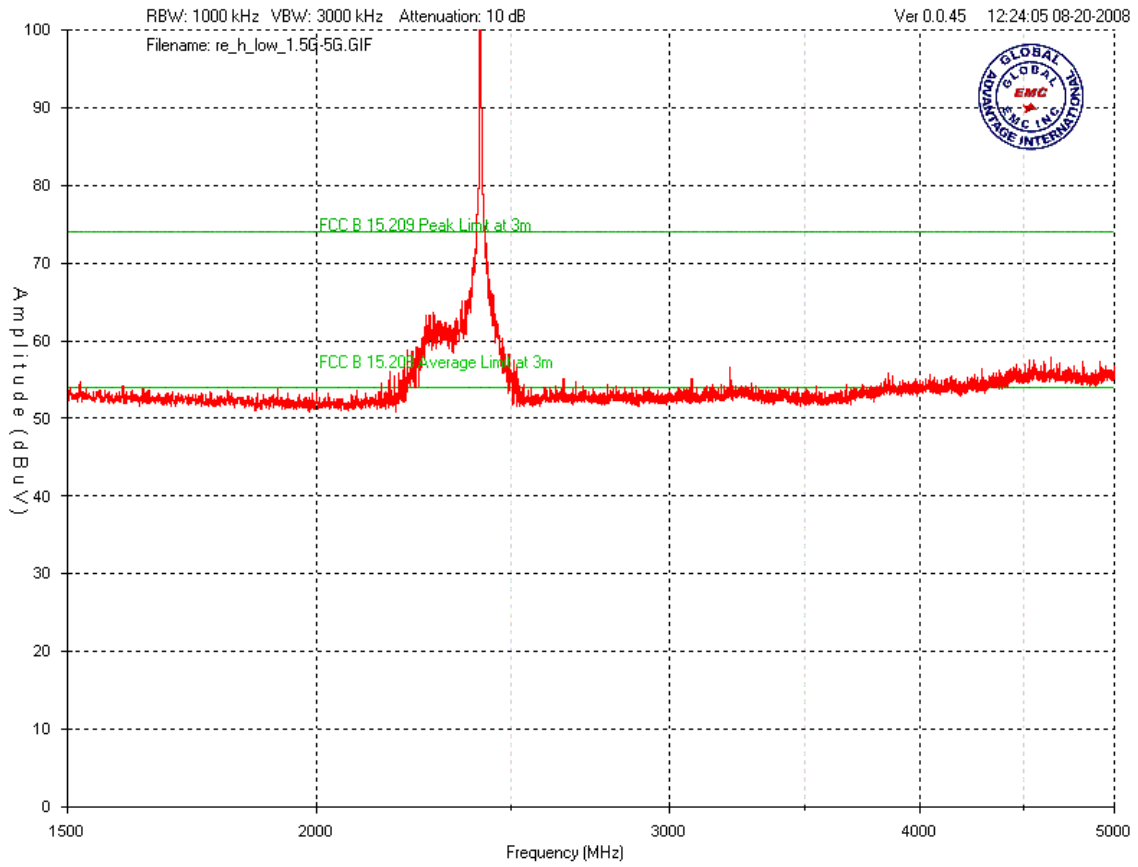

Client	Cypress	
Product	CY3271 FirstTouch RF Bridge	
Standard(s)	RSS 210 Issue 7:2007 / FCC Part 15 Subpart C 15:2008	

Radiated Emissions – Band Edge Low Channel (Worst case vertical polarity)

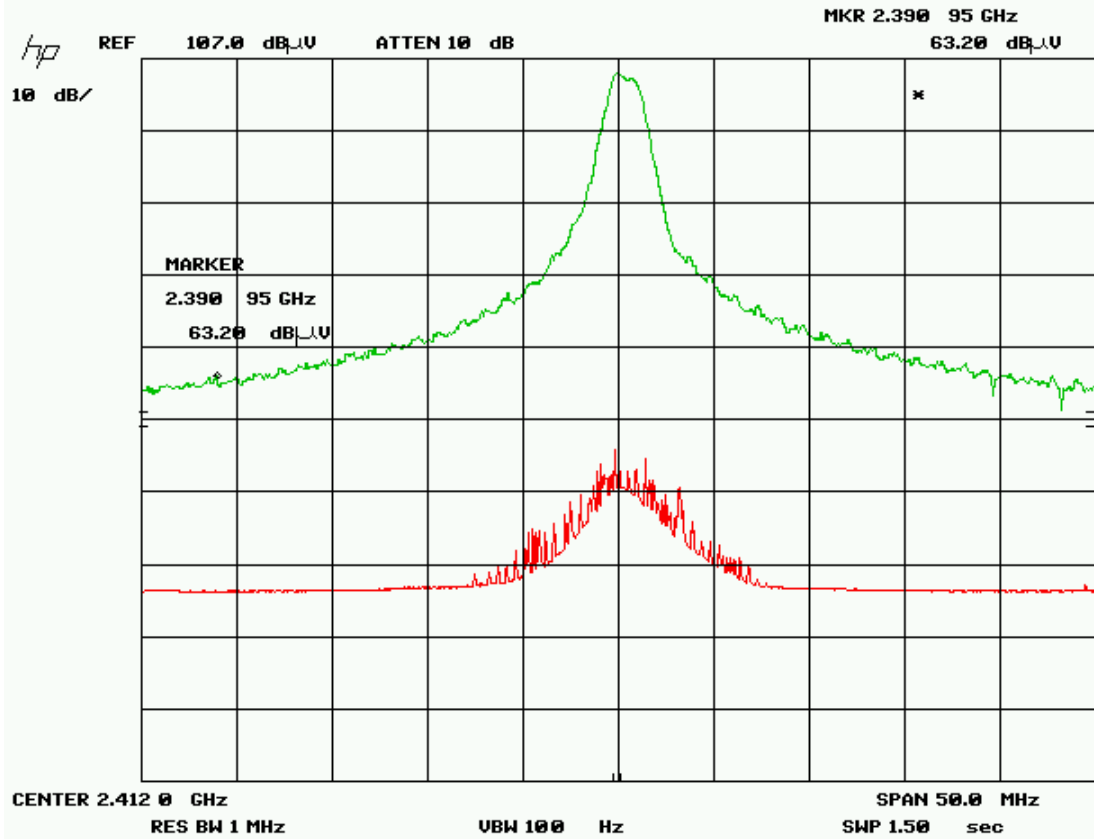

Client	Cypress	
Product	CY3271 FirstTouch RF Bridge	
Standard(s)	RSS 210 Issue 7:2007 / FCC Part 15 Subpart C 15:2008	

Radiated Emissions – Band Edge High Channel (worst case Vertical polarity)

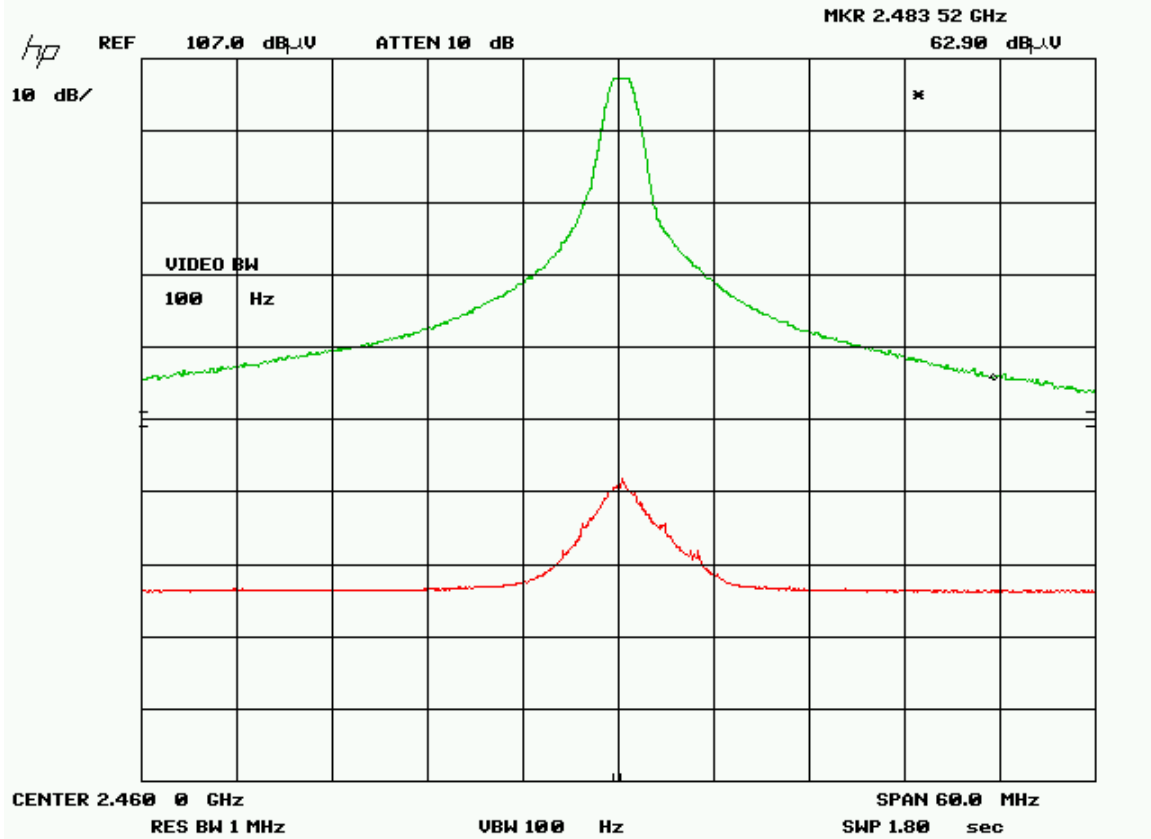

Client	Cypress	
Product	CY3271 FirstTouch RF Bridge	
Standard(s)	RSS 210 Issue 7:2007 / FCC Part 15 Subpart C 15:2008	

## Final Measurements

Note: In accordance with 15.247(d), only radiated emissions exceeding the 15.209 limit that occur within the bands listed in 15.205, need to be verified with a quasi-peak detector or an average detector. For information purposes, the top emissions were verified with the appropriate detector.

The requirement of -20dBc is verified by the conducted method, please see 'Spurious Antenna Conducted Emissions' section of this report.

### Quasi-Peak Measurements (30 MHz to 1 GHz)

Freq. (MHz)	Signal (dBuV)	Ant Pol	Ant. Factor (dB/m)	Cable Loss (dB)	Preamp Factor (dB)	Level (dBuV/m)	Limit (dBuV/m)	Margin (dB)	Restricted Band	Comments
31.164	36.7	V	18.2	0.3	-18.5	36.7	40	3.3	N	PASS
897.859	35.2	V	23.3	1.3	-18.5	41.3	46.4	5.1	N	PASS
223.127	46.1	V	11.3	0.6	-18.5	39.5	46.4	6.9	N	PASS
58.712	40.1	V	7.5	0.4	-18.5	29.5	40	10.5	N	PASS
900.769	36.8	H	23.4	1.3	-18.5	43	46.4	3.4	N	PASS
366.105	43.9	H	15.8	0.6	-18.4	41.9	46.4	4.5	N	PASS
399.861	40.9	H	16.3	0.6	-18.4	39.4	46.4	7	N*	PASS

\*Although the center frequency does not fall within a restricted band, when taking the measurement bandwidth into account portions of this measurement may encompass portions of the restricted band.

Client	Cypress	
Product	CY3271 FirstTouch RF Bridge	
Standard(s)	RSS 210 Issue 7:2007 / FCC Part 15 Subpart C 15:2008	

Test Frequency (MHz)	Detection mode	Antenna polarity (Horz/Vert)	Raw signal dB(µV)	Antenna factor dB	Cable loss dB + Preselector	Attenuator dB	Pre-Amp Gain dB	Received signal dB(µV/m)	Emission limit dB(µV/m)	Margin dB	Result
<b>Low Channel 2412</b>											
2412	Peak	Horz	100.8	31.6	4.0	10.0	36.0	110.4			PASS
2412	Avg	Horz	51.2	31.6	4.0	10.0	36.0	60.8			PASS
2412	Peak	Vert	104.8	31.6	4.0	10.0	36.0	114.4			PASS
2412	Avg	Vert	55.1	31.6	4.0	10.0	36.0	64.7			PASS
2390	Peak	Horz	61.2	31.6	4.0	10.0	36.0	70.8	74.0	3.2	PASS
2390	Avg	Horz	33.7	31.6	4.0	10.0	36.0	43.3	54.0	10.7	PASS
2390	Peak	Vert	63.2	31.6	4.0	10.0	36.0	72.8	74.0	1.2	PASS
2390	Avg	Vert	33.8	31.6	4.0	10.0	36.0	43.4	54.0	10.6	PASS
4824	Peak	Horz	46.2	30.0	11.0	0.0	36.0	51.2	74.0	22.8	PASS
4824	Avg	Horz	30.8	30.0	11.0	0.0	36.0	35.8	54.0	18.2	PASS
4824	Peak	Vert	48.6	30.0	11.0	0.0	36.0	53.6	74.0	20.4	PASS
4824	Avg	Vert	31.0	30.0	11.0	0.0	36.0	36.0	54.0	18.0	PASS
7236	Peak	Vert	46.0*	36.0	12.0	0.0	35.8	58.2	74.0	15.8	PASS
7236	Avg	Vert	34.0*	36.0	12.0	0.0	35.8	46.2	54.0	7.8	PASS
7236	Peak	Horz	46.0*	36.0	12.0	0.0	35.8	58.2	74.0	15.8	PASS
7236	Avg	Horz	34.0*	36.0	12.0	0.0	35.8	46.2	54.0	7.8	PASS
<b>Mid channel 2436</b>											
2436	Peak	Horz	100.8	31.6	4.0	10.0	36.0	110.4			PASS
2436	Avg	Horz	48.2	31.6	4.0	10.0	36.0	57.8			PASS
2436	Peak	Vert	104.1	31.6	4.0	10.0	36.0	113.7			PASS
2436	Avg	Vert	54.2	31.6	4.0	10.0	36.0	63.8			PASS
4872	Peak	Horz	48.5	30.0	11.0	0.0	36.0	53.5	74.0	20.5	PASS
4872	Avg	Horz	30.6	30.0	11.0	0.0	36.0	35.6	54.0	18.4	PASS
4872	Peak	Vert	49.8	30.0	11.0	0.0	36.0	54.8	74.0	19.2	PASS
4872	Avg	Vert	30.5	30.0	11.0	0.0	36.0	35.5	54.0	18.5	PASS
7308	Peak	Vert	46.0*	36.0	12.0	0.0	35.8	58.2	74.0	15.8	PASS
7308	Avg	Vert	34.0*	36.0	12.0	0.0	35.8	46.2	54.0	7.8	PASS
7308	Peak	Horz	46.0*	36.0	12.0	0.0	35.8	58.2	74.0	15.8	PASS
7308	Avg	Horz	34.0*	36.0	12.0	0.0	35.8	46.2	54.0	7.8	PASS
<b>High Channel 2460</b>											
2460	Peak	Horz	102.1	31.6	4.0	10.0	36.0	111.7			PASS
2460	Avg	Horz	52.1	31.6	4.0	10.0	36.0	61.7			PASS
2460	Peak	Vert	106.3	31.5	4.0	10.0	36.0	115.8			PASS
2460	Avg	Vert	56.8	31.6	4.0	10.0	36.0	66.4			PASS
2483.5	Peak	Horz	61.5	31.6	4.0	10.0	36.0	71.1	74.0	2.9	PASS
2483.5	Avg	Horz	33.0	31.6	4.0	10.0	36.0	42.6	54.0	11.4	PASS

Client	Cypress									
Product	CY3271 FirstTouch RF Bridge									
Standard(s)	RSS 210 Issue 7:2007 / FCC Part 15 Subpart C 15:2008									



2483.5	Peak	Vert	62.9	31.6	4.0	10.0	36.0	72.5	74.0	1.5	PASS
2483.5	Avg	Vert	33.3	31.6	4.0	10.0	36.0	42.9	54.0	11.1	PASS
4920	Peak	Horz	49.6	30.0	11.0	0.0	36.0	54.6	74.0	19.4	PASS
4920	Avg	Horz	36.0	30.0	11.0	0.0	36.0	41.0	54.0	13.0	PASS
4920	Peak	Vert	49.9	30.0	11.0	0.0	36.0	54.9	74.0	19.1	PASS
4920	Avg	Vert	36.2	30.0	11.0	0.0	36.0	41.2	54.0	12.8	PASS
7380	Peak	Vert	46.0*	36.0	12.0	0.0	35.8	58.2	74.0	15.8	PASS
7380	Avg	Vert	34.0*	36.0	12.0	0.0	35.8	46.2	54.0	7.8	PASS
7380	Peak	Horz	46.0*	36.0	12.0	0.0	35.8	58.2	74.0	15.8	PASS
7380	Avg	Horz	34.0*	36.0	12.0	0.0	35.8	46.2	54.0	7.8	PASS

Note (\*): No emission was detected, however the approximate instrument noise floor is reported.

For information purposes, the fundamental was measured to be 111.7 dBuV/m at 3 meters, and none of the unintentional radiated emissions that fall outside of the restricted bands exceeded the -20dBc (or 91.7 dBuV/m) requirement.

See ‘Spurious Antenna Conducted Emissions’ measurements for -20 dBc requirements.

Note: Radiated emissions measurements above 8 GHz were performed at a 1 meter test distance, and in accordance with FCC 15.31(f)(1) an extrapolation factor of 9.5 dB was applied. No emissions above the 3<sup>rd</sup> harmonic were detected at 1 meter. The system noise floor at the 10<sup>th</sup> harmonic was approximately 12 dB at 1m.

Client	Cypress	
Product	CY3271 FirstTouch RF Bridge	
Standard(s)	RSS 210 Issue 7:2007 / FCC Part 15 Subpart C 15:2008	

## Test Equipment List

Equipment	Model No.	Manufacturer	Last calibration date	Next calibration due date	Asset #
Spectrum Analyzer	8566B	HP	2008-02-28	2010-02-28	GEMC 6
Quasi Peak Adapter	85650A	HP	2008-02-28	2010-02-28	GEMC 7
BiLog Antenna	3142-C	ETS	2006-08-06	2008-10-01	GEMC 8
Horn Antenna	6878/24	Q-Par	On file	2008-10-01	GEMC 65
1-26G pre-amp	HP 8449B	HP	On file	2008-10-01	GEMC 68
Attenuator 3 dB	FP-50-3	Trilithic	NCR	NCR	GEMC 40
Pre-Amplifier	PA-2.5-26	Vican	2006-09-12	2008-09-12	GEMC 9
IFR Spectrum Analyzer	AN940	IFR	On file	2008-10-01	GEMC 6350
Horn Antenna	SAS-572	AH	NCR	NCR	GEMC 6371
RF Cable 7m	LMR-400-7M-50OHM-MN-MN	LexTec	NCR	NCR	GEMC 28
RF Cable 1m	LMR-400-1M-50OHM-MN-MN	LexTec	NCR	NCR	GEMC 29
RF Cable 0.5M	LMR-400-0.5M-50OHM-MN-MN	LexTec	NCR	NCR	GEMC 31

This report module is based on GEMC template "FCC - 15.209 - Radiated Emissions\_Rev2.doc"

Client	Cypress	
Product	CY3271 FirstTouch RF Bridge	
Standard(s)	RSS 210 Issue 7:2007 / FCC Part 15 Subpart C 15:2008	

## ***6dB Bandwidth of Digitally Modulated Systems***

### **Purpose**

The purpose of this test is to ensure that the bandwidth occupied exceeds a stated minimum. This helps ensure the utilization of the frequency allocation is sufficiently wide. This also helps prevent corruption of data by ensuring adequate data separation to distinguish the reception of the intended information.

### **Limits**

The Limit is as specified in FCC Part 15 and RSS 210.

Systems using digital modulation techniques may operate in the 902 - 928 MHz, 2400 - 2483.5 MHz, and 5725 - 5850 MHz bands. The minimum 6 dB bandwidth shall be at least 500 kHz. This should be measured with a 100 kHz RBW and a 300 kHz VBW.

### **Results**

The EUT passed. The 6 dB BW measured was 1.268 MHz



Client	Cypress	
Product	CY3271 FirstTouch RF Bridge	
Standard(s)	RSS 210 Issue 7:2007 / FCC Part 15 Subpart C 15:2008	

## Graph(s)

The graphs shown below shows the channel spacing during the operation of the device. This is measured by a max hold on the spectrum analyzer and the highest resolution bandwidth that is sufficiently low to exhibit the 6 dB bandwidth of a channel during operation of the EUT. This measurement is a peak measurement. Max hold is performed for a duration of not less than 1 minute.

Client	Cypress	
Product	CY3271 FirstTouch RF Bridge	
Standard(s)	RSS 210 Issue 7:2007 / FCC Part 15 Subpart C 15:2008	

Low Channel

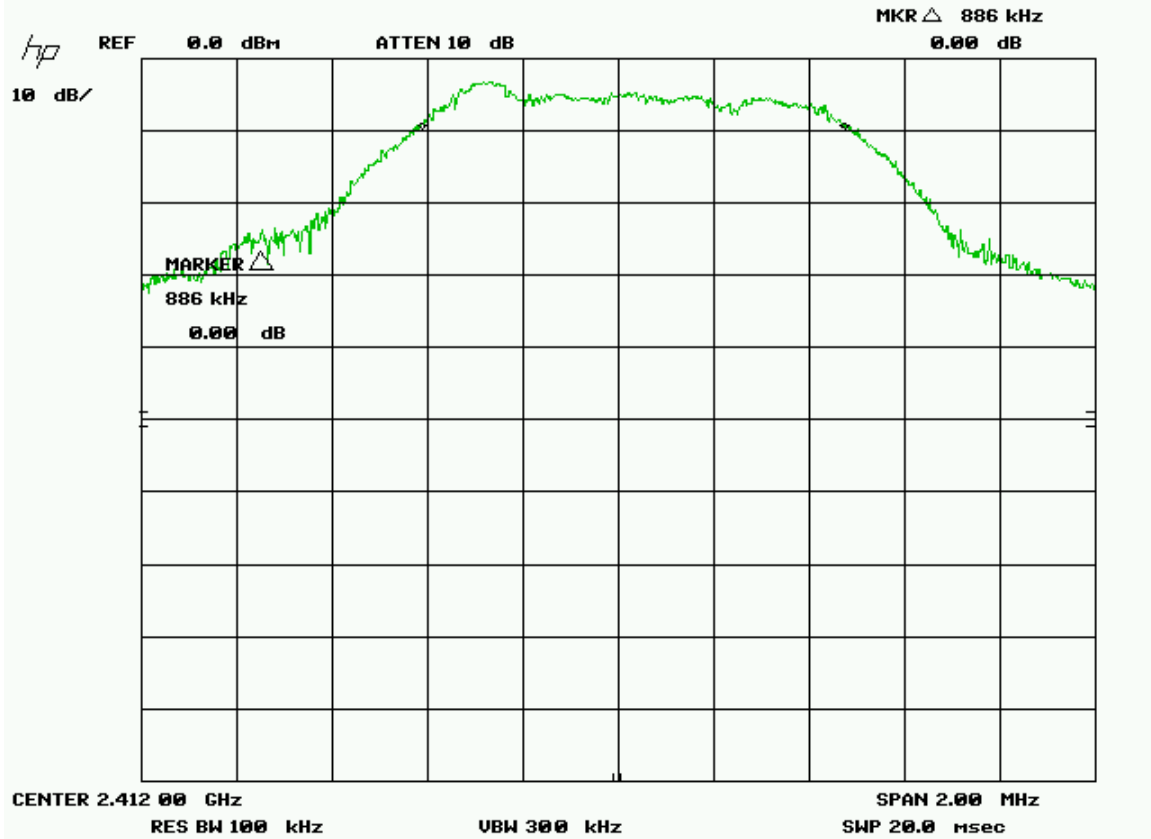

Client	Cypress	
Product	CY3271 FirstTouch RF Bridge	
Standard(s)	RSS 210 Issue 7:2007 / FCC Part 15 Subpart C 15:2008	

Middle Channel

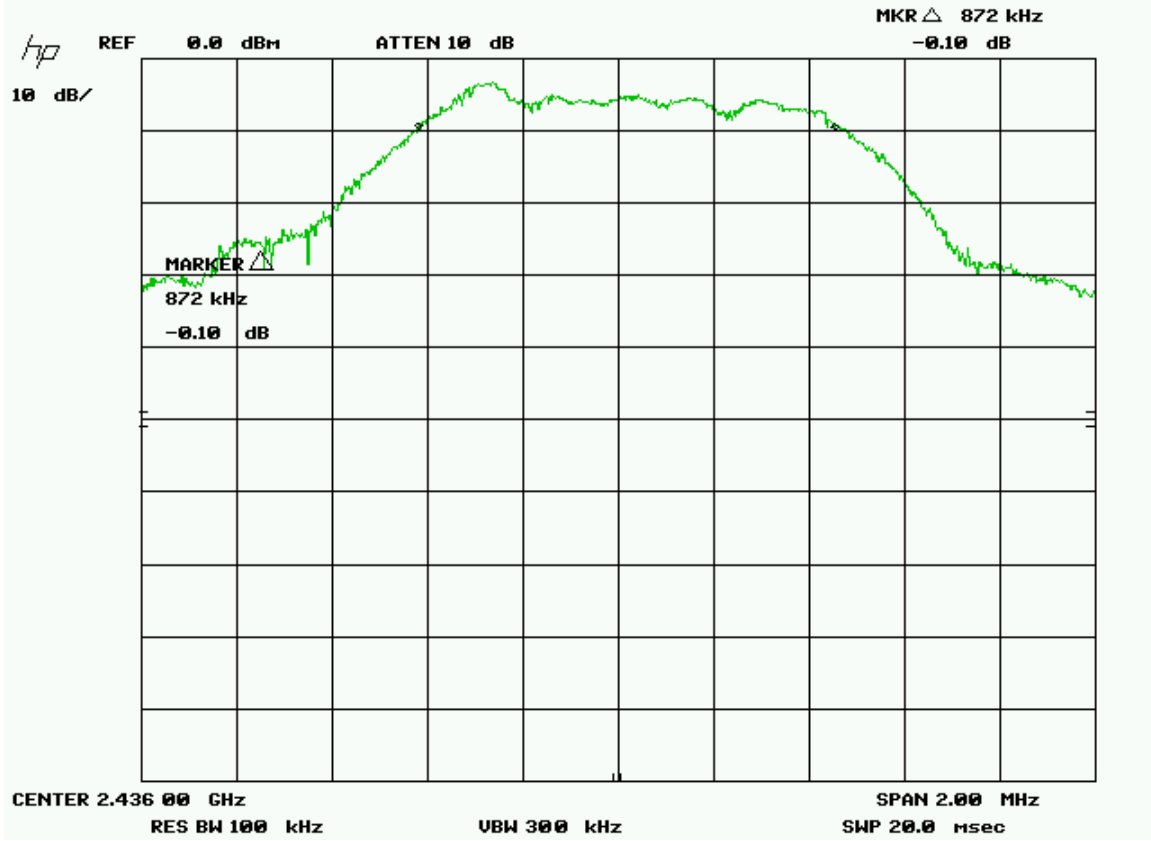

Client	Cypress	
Product	CY3271 FirstTouch RF Bridge	
Standard(s)	RSS 210 Issue 7:2007 / FCC Part 15 Subpart C 15:2008	

High Channel

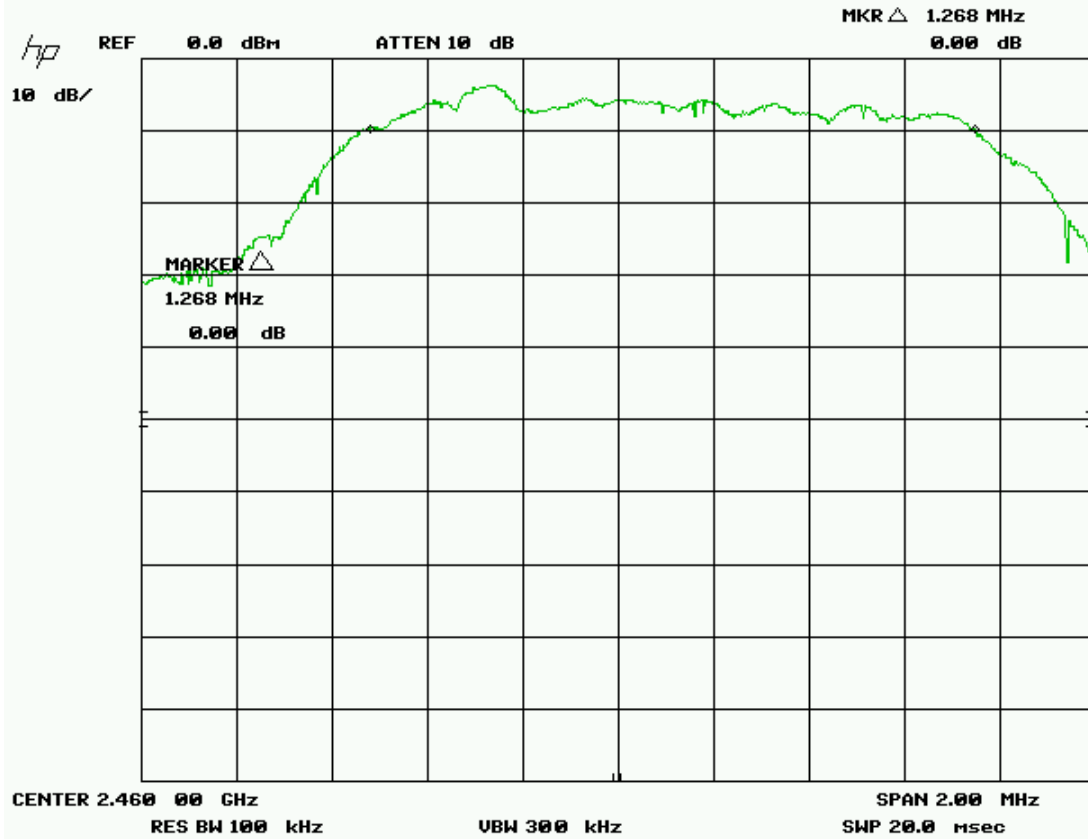

Note: See 'Appendix B – EUT & Test Setup Photographs' for photos showing the test set-up.

Client	<b>Cypress</b>	
Product	CY3271 FirstTouch RF Bridge	
Standard(s)	RSS 210 Issue 7:2007 / FCC Part 15 Subpart C 15:2008	

## Test Equipment List

Equipment	Model No.	Manufacturer	Last calibration date	Next calibration due date	Asset #
Attenuator 20 dB	FP-50-20	Trilithic	NCR	NCR	GEMC 43
Spectrum Analyzer	8566B	HP	2008-02-28	2010-02-28	GEMC 6
Quasi Peak Adapter	85650A	HP	2008-02-28	2010-02-28	GEMC 7
RF Cable 1m	LMR-400-1M-50OHM-MN-MN	LexTec	NCR	NCR	GEMC 29
Power Attenuator 20 dB	25-A-FFN-20	Bird / Hutton	NCR	NCR	GEMC 49

This report module is based on GEMC template "FCC – Power Line Conducted Emissions Class B\_Rev1"

Client	Cypress	
Product	CY3271 FirstTouch RF Bridge	
Standard(s)	RSS 210 Issue 7:2007 / FCC Part 15 Subpart C 15:2008	

## ***Maximum Peak Envelope Conducted Power***

### **Purpose**

The purpose of this test is to ensure that the maximum power conducted to the radiating element does not exceed the limits specified. This ensures that if the end-user replaces the antenna, that the maximum power does not exceed an amount which may create an excessive power level.

### **Limits**

The limits are defined in FCC Part 15.247(b) and RSS 210. For systems using digital modulation in the 902-928 MHz, 2400-2483.5 MHz, and 5725-5850 MHz bands, the peak limit is 1 watt.

### **Results**

The EUT passed. The peak power measured was 18.1 dBm (64.5 mW)

Client	Cypress	
Product	CY3271 FirstTouch RF Bridge	
Standard(s)	RSS 210 Issue 7:2007 / FCC Part 15 Subpart C 15:2008	

### Table(s)

The tables shown below shows the peak power output of the device during the antenna conducted measurement during transmit operation of the EUT. Note there was 20 dB of external attenuation taken during this measurement.

#### 802.11g mode

Band	Channel	Frequency (GHz)	Reading (dBm)	Factor (dB)	Output Power (dBm)
Low	6	2.412	-1.9	20	18.1
Medium	18	2.436	-2.3	20	17.7
High	30	2.460	-2.5	20	17.5

The calculated value is:

$$\begin{aligned}
 & -2.9 \text{ dBm} + 20 \text{ dB (attenuator)} \\
 & = 18.1
 \end{aligned}$$

Note: See 'Appendix B – EUT & Test Setup Photographs' for photos showing the test set-up.

Client	<b>Cypress</b>	
Product	CY3271 FirstTouch RF Bridge	
Standard(s)	RSS 210 Issue 7:2007 / FCC Part 15 Subpart C 15:2008	

## Test Equipment List

Equipment	Model No.	Manufacturer	Last calibration date	Next calibration due date	Asset #
Power Head	PH 2000	AR	2006-10-13	2008-10-13	GEMC 15
Power meter	PM 2002	AR	2006-10-13	2008-10-13	GEMC 16
RF Cable 1m	LMR-400-1M-50OHM-MN-MN	LexTec	NCR	NCR	GEMC 29
Power Attenuator 20 dB	25-A-FFN-20	Bird / Hutton	NCR	NCR	GEMC 49

This report module is based on GEMC template "FCC – Power Line Conducted Emissions Class B\_Rev1"



Client	Cypress	
Product	CY3271 FirstTouch RF Bridge	
Standard(s)	RSS 210 Issue 7:2007 / FCC Part 15 Subpart C 15:2008	

## ***Spurious Conducted Emissions***

### **Purpose**

The purpose of this test is to ensure that the maximum power conducted to the radiating element at frequencies outside of the authorized spectrum does not exceed the limits specified. This ensures that the only the intended signal is delivered to the radiating element.

### **Limits**

The limits are defined in 15.247(d). In any 100 kHz band, the peak spurious harmonics emissions must be at least 20 dB below the fundamental. Spurious Conducted emissions are to be evaluated up to the 10<sup>th</sup> harmonic. This -20 dBc requirement also applies at the 'band edge' or 2.4 GHz and 2.4835 GHz.

### **Results**

The EUT pass. Low, middle and high band was measured. The worst case for each mode is presented as a graph for the spectrum. The -20 dBc requirement is shown for the lower band edge at 2.4 GHz in the low band. The -20 dBc requirement is also shown for the higher band edge at 2.4835 GHz in the high band.

Client	Cypress	
Product	CY3271 FirstTouch RF Bridge	
Standard(s)	RSS 210 Issue 7:2007 / FCC Part 15 Subpart C 15:2008	

### Graph(s)

The graphs shown below shows the peak power output of the device during the antenna conducted measurement during transmit operation of the EUT. Note there was 20 dB of external attenuation taken during this measurement.

Frequencies below fundamental  
Low channel

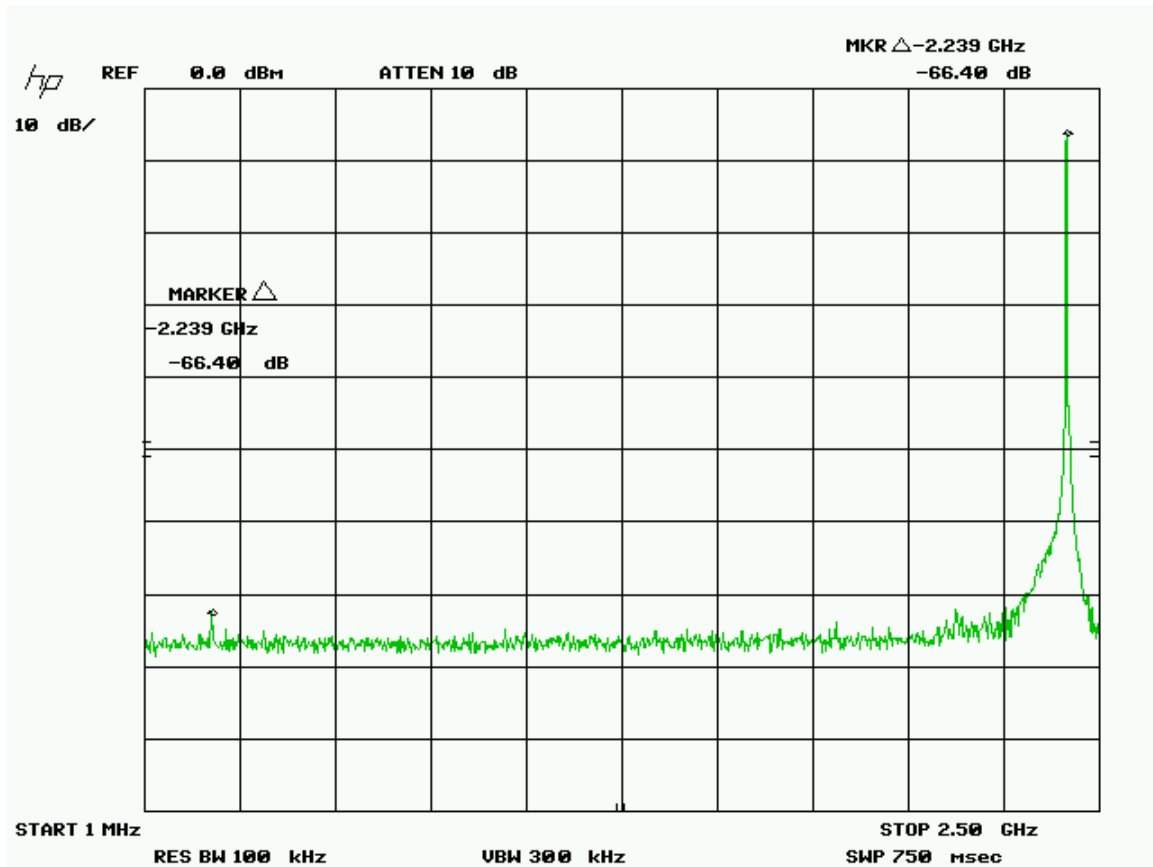

Client	Cypress	
Product	CY3271 FirstTouch RF Bridge	
Standard(s)	RSS 210 Issue 7:2007 / FCC Part 15 Subpart C 15:2008	

Low Channel, Lower Band Edge

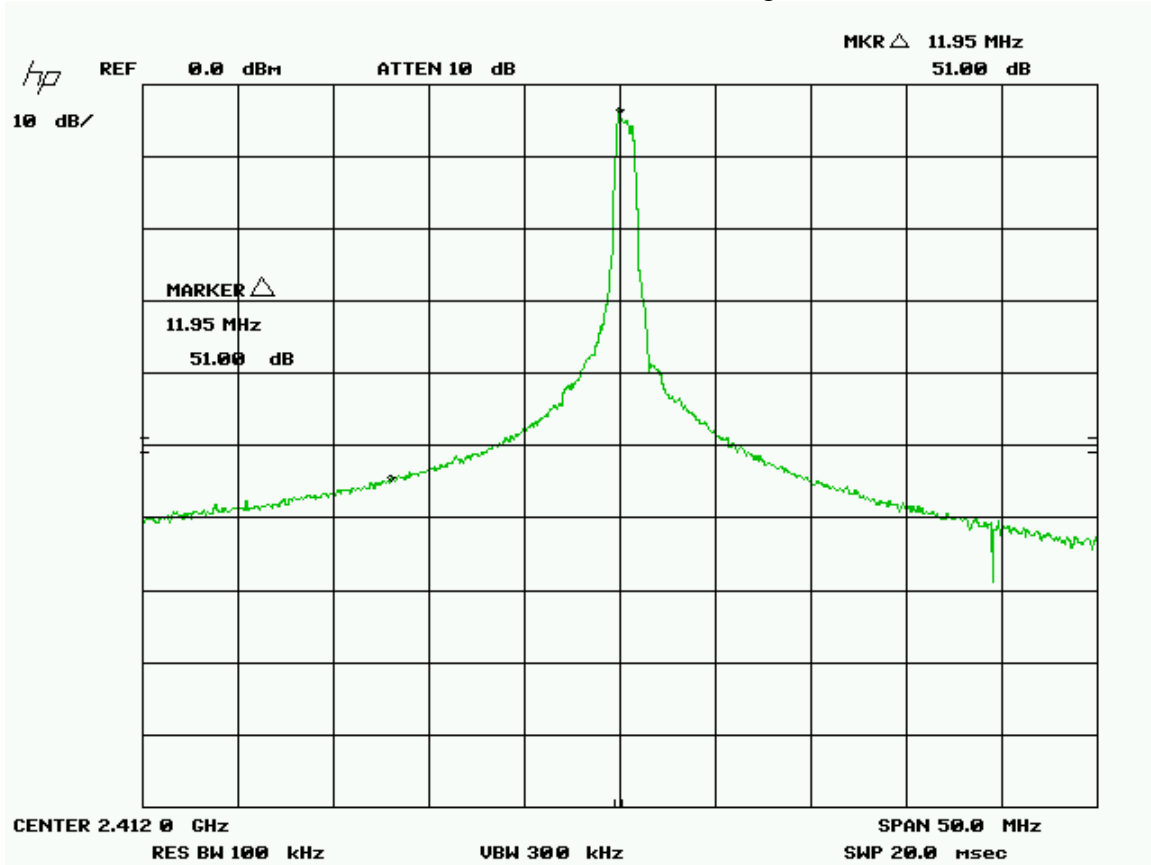

Client	Cypress	
Product	CY3271 FirstTouch RF Bridge	
Standard(s)	RSS 210 Issue 7:2007 / FCC Part 15 Subpart C 15:2008	

Low Channel – Frequencies above fundamental

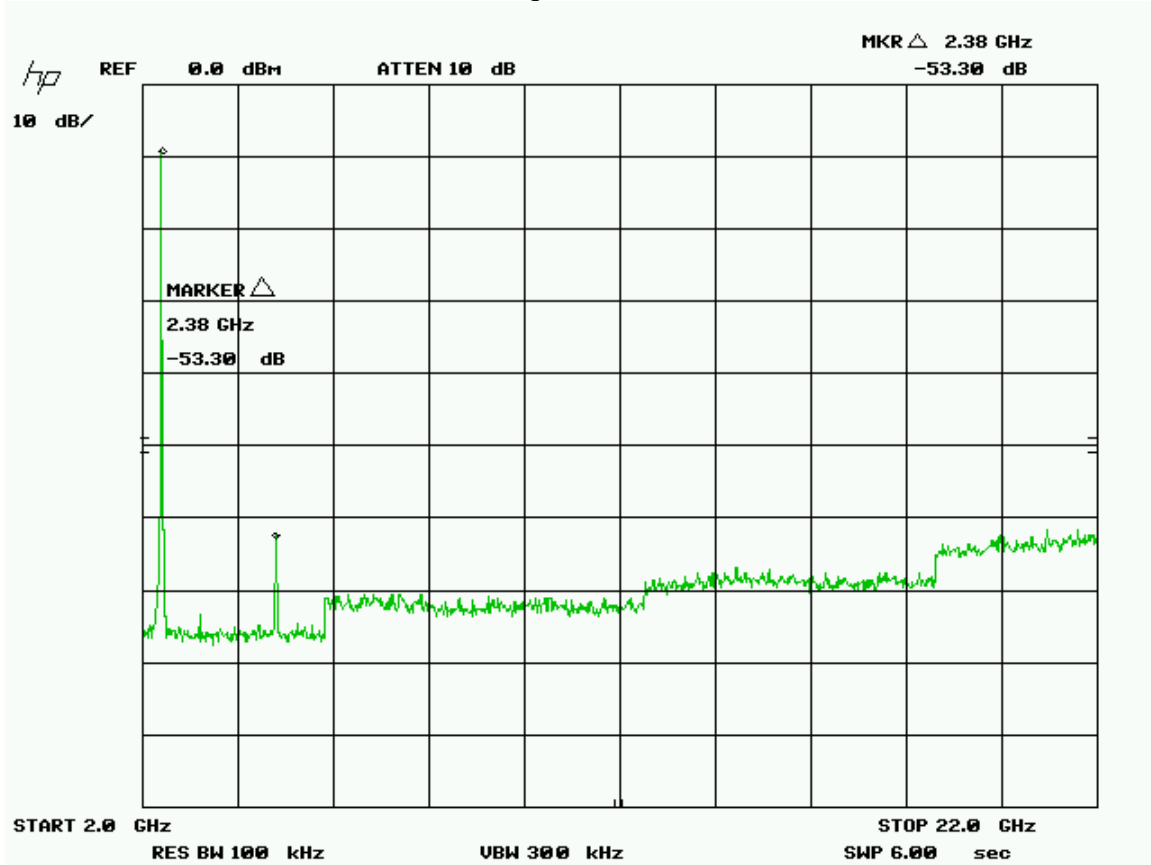

Client	Cypress	
Product	CY3271 FirstTouch RF Bridge	
Standard(s)	RSS 210 Issue 7:2007 / FCC Part 15 Subpart C 15:2008	

Middle Channel – Frequencies below fundamental

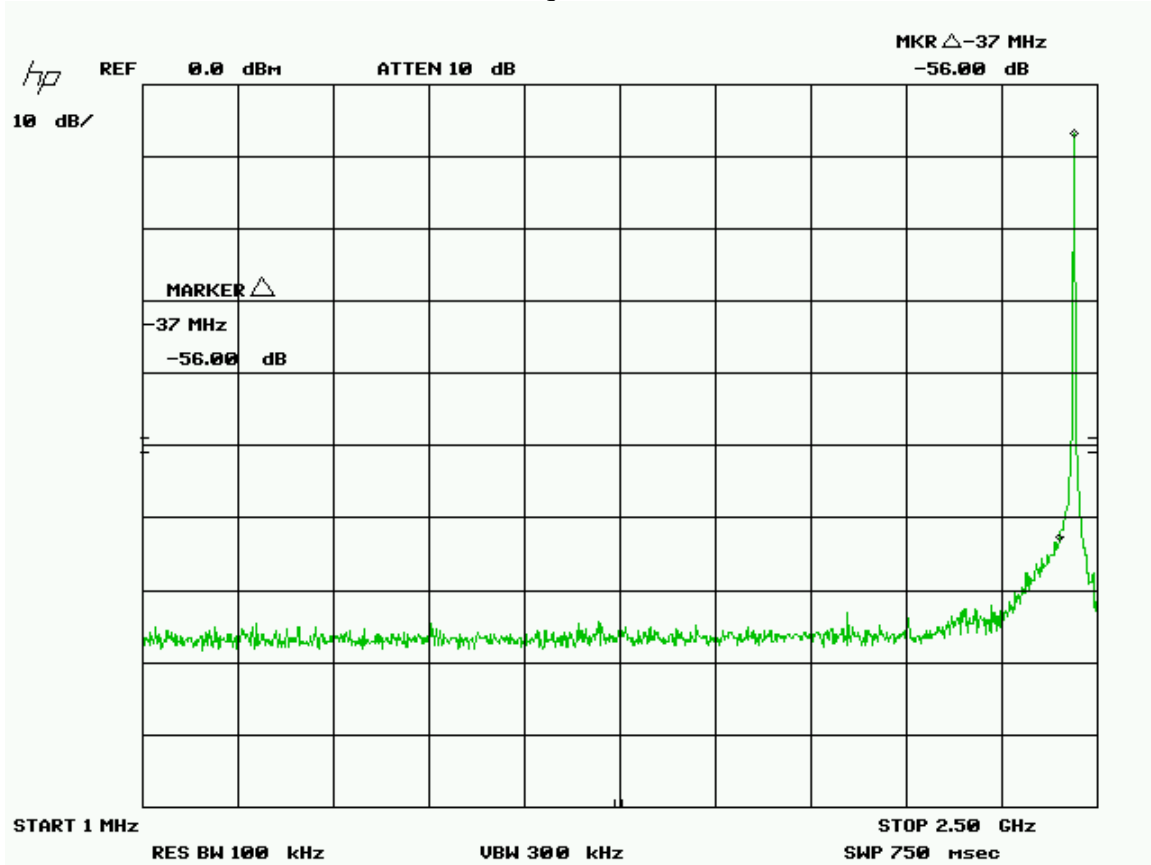

Client	Cypress	
Product	CY3271 FirstTouch RF Bridge	
Standard(s)	RSS 210 Issue 7:2007 / FCC Part 15 Subpart C 15:2008	

Middle Channel – Frequencies above fundamental

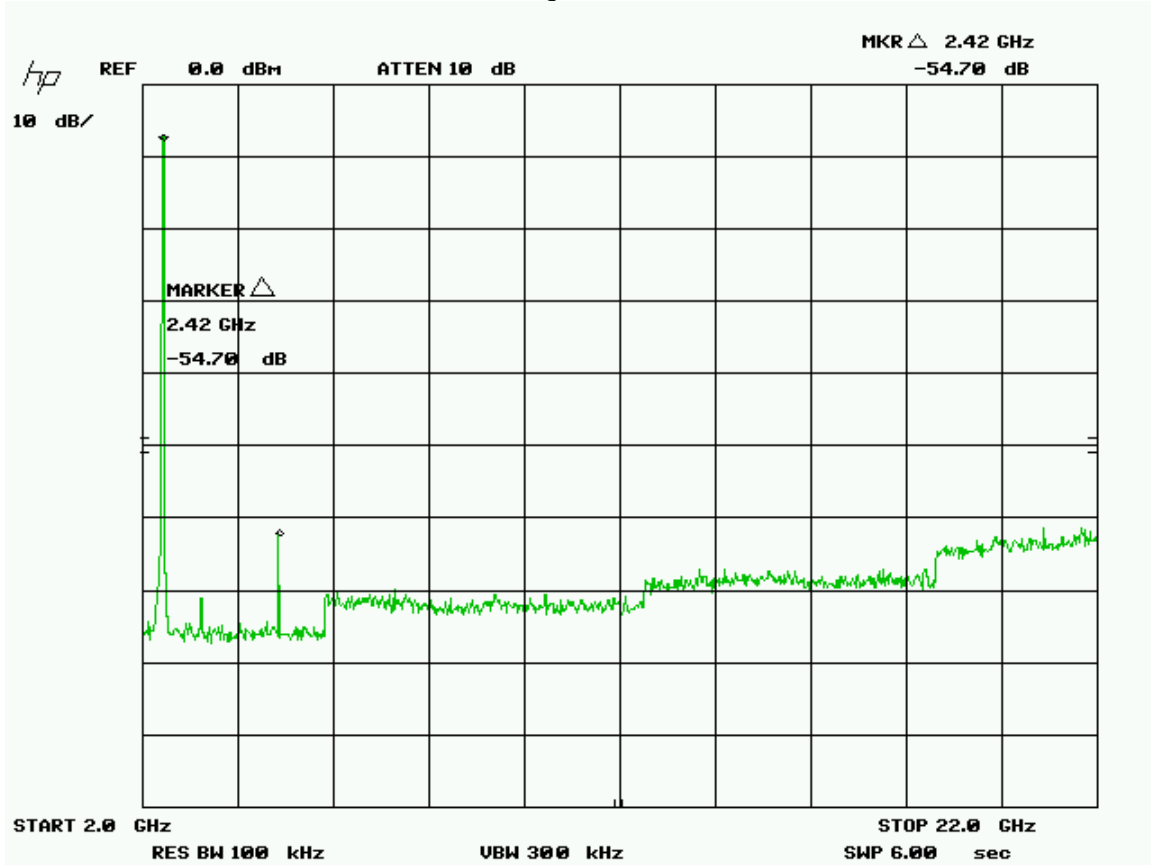

Client	Cypress	
Product	CY3271 FirstTouch RF Bridge	
Standard(s)	RSS 210 Issue 7:2007 / FCC Part 15 Subpart C 15:2008	

High Channel – Frequencies below fundamental

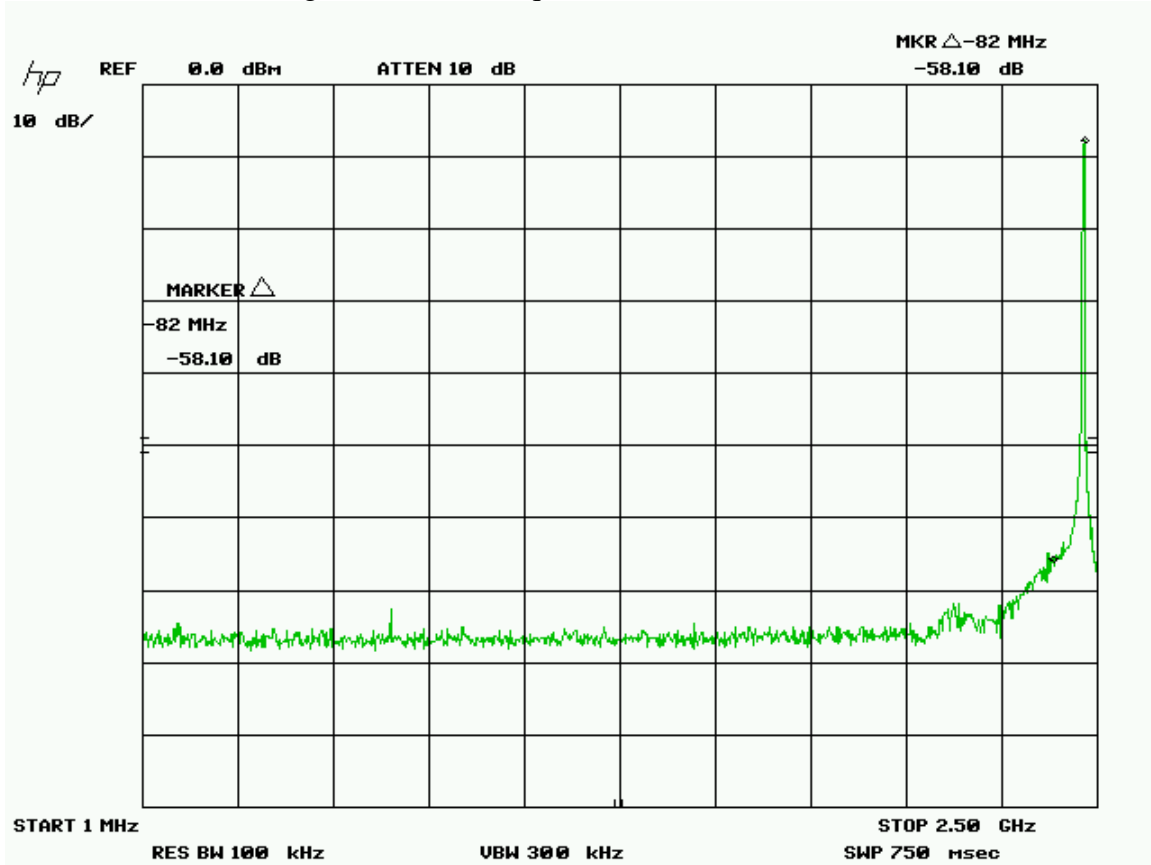

Client	Cypress	
Product	CY3271 FirstTouch RF Bridge	
Standard(s)	RSS 210 Issue 7:2007 / FCC Part 15 Subpart C 15:2008	

High Channel, Upper Band Edge

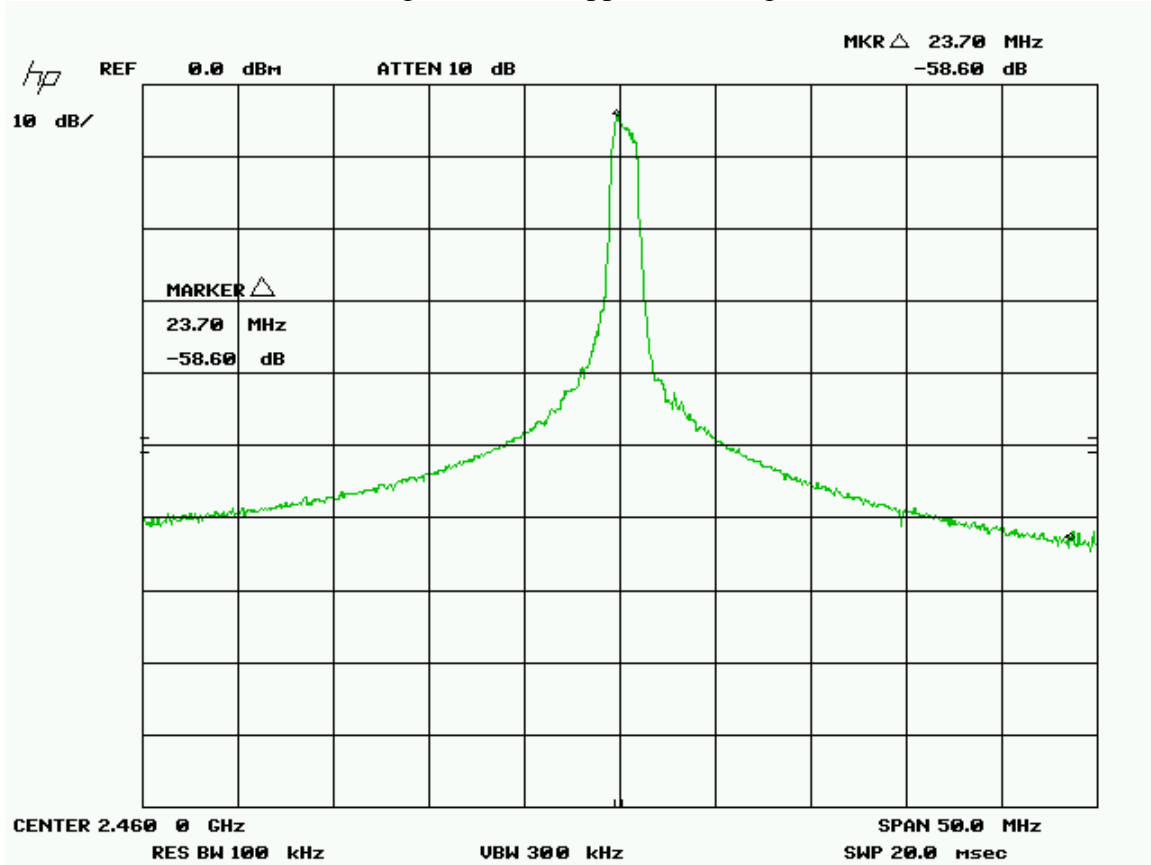



Client	Cypress	
Product	CY3271 FirstTouch RF Bridge	
Standard(s)	RSS 210 Issue 7:2007 / FCC Part 15 Subpart C 15:2008	

High Channel – Frequencies above fundamental

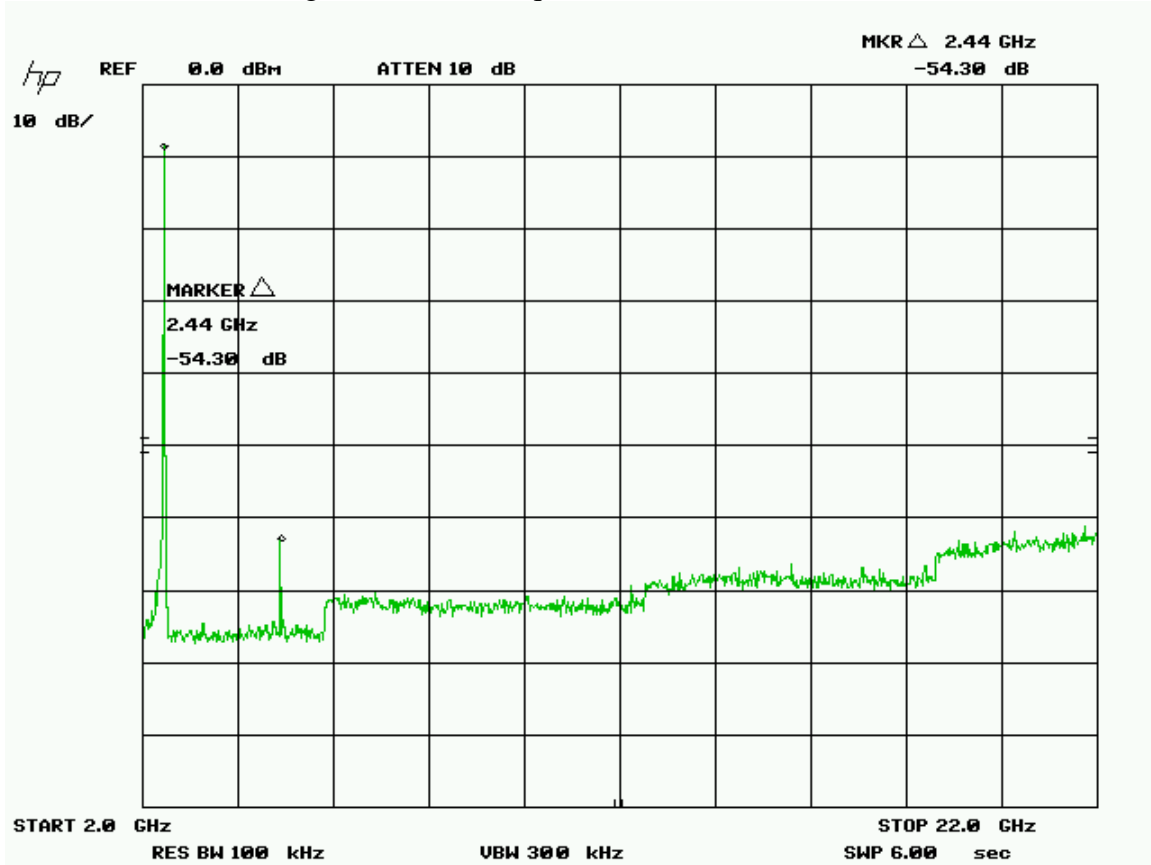

Client	<b>Cypress</b>	
Product	CY3271 FirstTouch RF Bridge	
Standard(s)	RSS 210 Issue 7:2007 / FCC Part 15 Subpart C 15:2008	

The frequency range of 22 – 25 GHz, the 10<sup>th</sup> harmonic and 9<sup>th</sup> harmonic where applicable, was additionally scanned using an alternate spectrum analyzer, in low, middle and high band for each mode. No emissions were detected at the 9<sup>th</sup> and 10<sup>th</sup> harmonic.

Note: See ‘Appendix B – EUT & Test Setup Photographs’ for photos showing the test set-up.

### Test Equipment List

Equipment	Model No.	Manufacturer	Last calibration date	Next calibration due date	Asset #
Attenuator 1 dB	FP-50-1	Trilithic	NCR	NCR	GEMC 38
Attenuator 3 dB	FP-50-3	Trilithic	NCR	NCR	GEMC 40
Attenuator 6 dB	FP-50-6	Trilithic	NCR	NCR	GEMC 41
Attenuator 10 dB	FP-50-10	Trilithic	NCR	NCR	GEMC 42
Attenuator 20 dB	FP-50-20	Trilithic	NCR	NCR	GEMC 43
Spectrum Analyzer	8566B	HP	2008-02-28	2010-02-28	GEMC 6
Quasi Peak Adapter	85650A	HP	2008-02-28	2010-02-28	GEMC 7
IFR Spectrum Analyzer	AN940	IFR	On file	2008-10-01	GEMC 6350
RF Cable 1m	LMR-400-1M-50OHM-MN-MN	LexTec	NCR	NCR	GEMC 29
Power Attenuator 20 dB	25-A-FFN-20	Bird / Hutton	NCR	NCR	GEMC 49

This report module is based on GEMC template “FCC – Power Line Conducted Emissions Class B\_Rev1”

Client	Cypress	
Product	CY3271 FirstTouch RF Bridge	
Standard(s)	RSS 210 Issue 7:2007 / FCC Part 15 Subpart C 15:2008	

## **Maximum Permissible Exposure**

### **Purpose**

The purpose of this test is to ensure that the RF energy intentionally transmitted, in terms of power density emitted from the EUT at a stated operating distance does not exceed the limits listed below as defined in the applicable test standard, as calculated based upon readings obtained during testing. This helps protect human exposure to excessive RF fields.

### **Limit(s) and Method**

The limits, as defined in FCC 15.247(i), and FCC 1.1310 Table 1 (B) limits for general public exposure was applied. The limit for the frequency range of 1.5 GHz to 100 GHz was applied. This is a limit of 1.0 mW/ cm<sup>2</sup> The distance used for calculations was 20cm, as this is the minimum distance an operator will be from the EUT during normal operation, as stated by the manufacturer.

Client	Cypress	
Product	CY3271 FirstTouch RF Bridge	
Standard(s)	RSS 210 Issue 7:2007 / FCC Part 15 Subpart C 15:2008	

## Results

The EUT passed the requirements. The worst case calculated power density was 0.02 mW/cm<sup>2</sup>, this is significantly under the 1.0 mW/cm<sup>2</sup> requirement.

## Calculations

Method 1 (conducted power)

$$P_d = (P_t * G) / (4 * \pi * R^2)$$

Where  $P_t = 18.1$  or  $64.5$  mW as per Peak power conducted output

Where  $G = 3$  dBi, or numerically 2

Where  $R = 20$  cm

$$P_d = (64.5 \text{ mW} * 2) / (4 * \pi * 20\text{cm}^2)$$

$$P_d = 64.5 \text{ mW} / 5026 \text{ cm}^2$$

$$P_d = 0.012 \text{ mW/cm}^2$$

Client	Cypress	
Product	CY3271 FirstTouch RF Bridge	
Standard(s)	RSS 210 Issue 7:2007 / FCC Part 15 Subpart C 15:2008	

## Appendix A – EUT Summary

For further details for filing purposes, refer to filing package.

### General EUT Description

Client Details	
Organization / Address	Cypress Semiconductor 198 Champion ct, San Jose CA 95134
EUT (Equipment Under Test) Details	
EUT Name (for report title)	CY3271 FirstTouch RF Bridge
EUT Model	CY3271
EUT is powered using	DC Powered via USB interface
Input voltage range(s) (V)	5.0V
Input Frequency range(s) (Hz)	0
Rated input current (A)	0.3
Nominal power consumption (W)	1.5
Dimensions of product	L 73 mm W 31 mm H 14 mm Weight 42 grams

Note the EUT is considered to have been received the date of the commencement of the first test, unless otherwise stated. For a close-up picture of the EUT, see ‘Appendix B – EUT & Test Setup Photographs’.

Client	<b>Cypress</b>	
Product	CY3271 FirstTouch RF Bridge	
Standard(s)	RSS 210 Issue 7:2007 / FCC Part 15 Subpart C 15:2008	

## Appendix B – EUT and Test Setup Photographs

Client	Cypress	
Product	CY3271 FirstTouch RF Bridge	
Standard(s)	RSS 210 Issue 7:2007 / FCC Part 15 Subpart C 15:2008	

Note: These photos are for information purposes only. Also refer to PDF photo exhibit files that are separate from this test report.

Power Line Conducted Emissions Test Setup Photo



Client	Cypress	
Product	CY3271 FirstTouch RF Bridge	
Standard(s)	RSS 210 Issue 7:2007 / FCC Part 15 Subpart C 15:2008	

Radiated Emissions Test Setup Photo 1

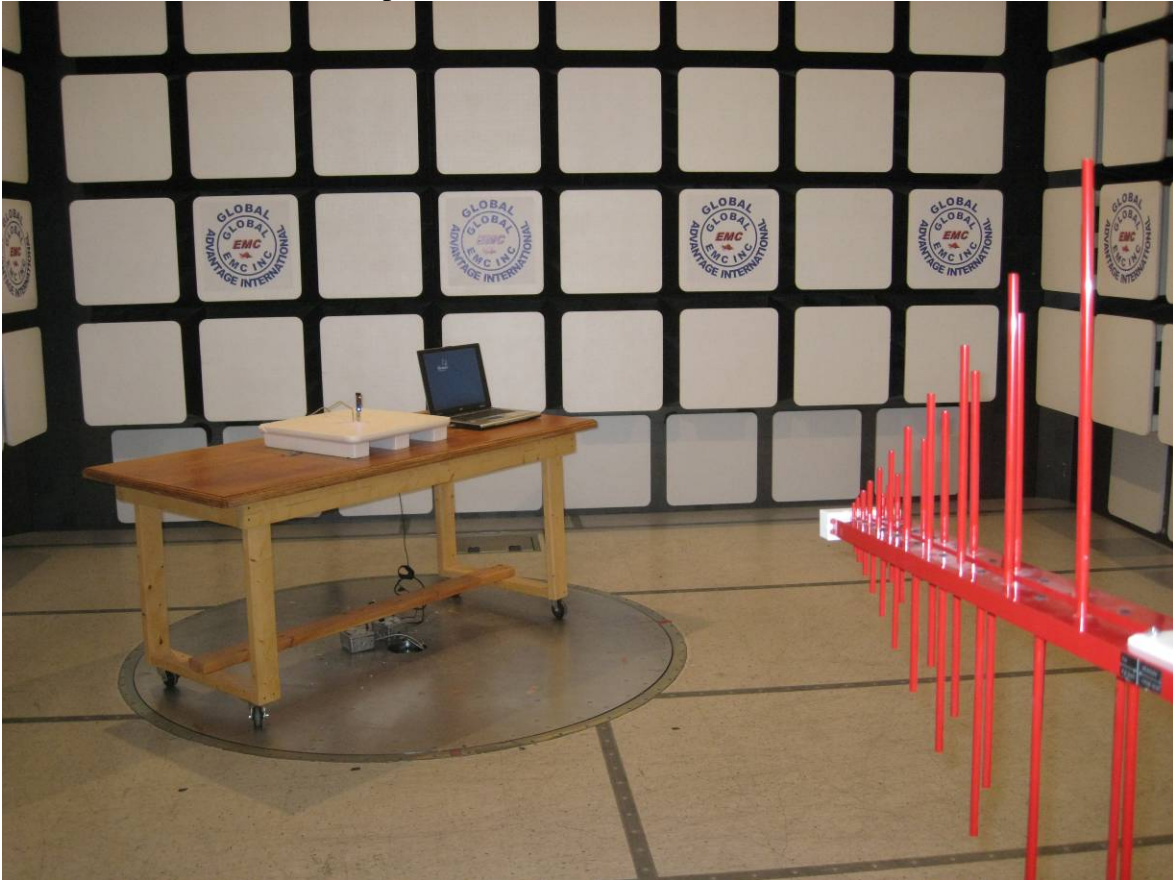



Client	Cypress	
Product	CY3271 FirstTouch RF Bridge	
Standard(s)	RSS 210 Issue 7:2007 / FCC Part 15 Subpart C 15:2008	

Radiated Emissions Test Setup Photo 2



Client	Cypress	
Product	CY3271 FirstTouch RF Bridge	
Standard(s)	RSS 210 Issue 7:2007 / FCC Part 15 Subpart C 15:2008	

Radiated Emissions Test Setup Photo 3

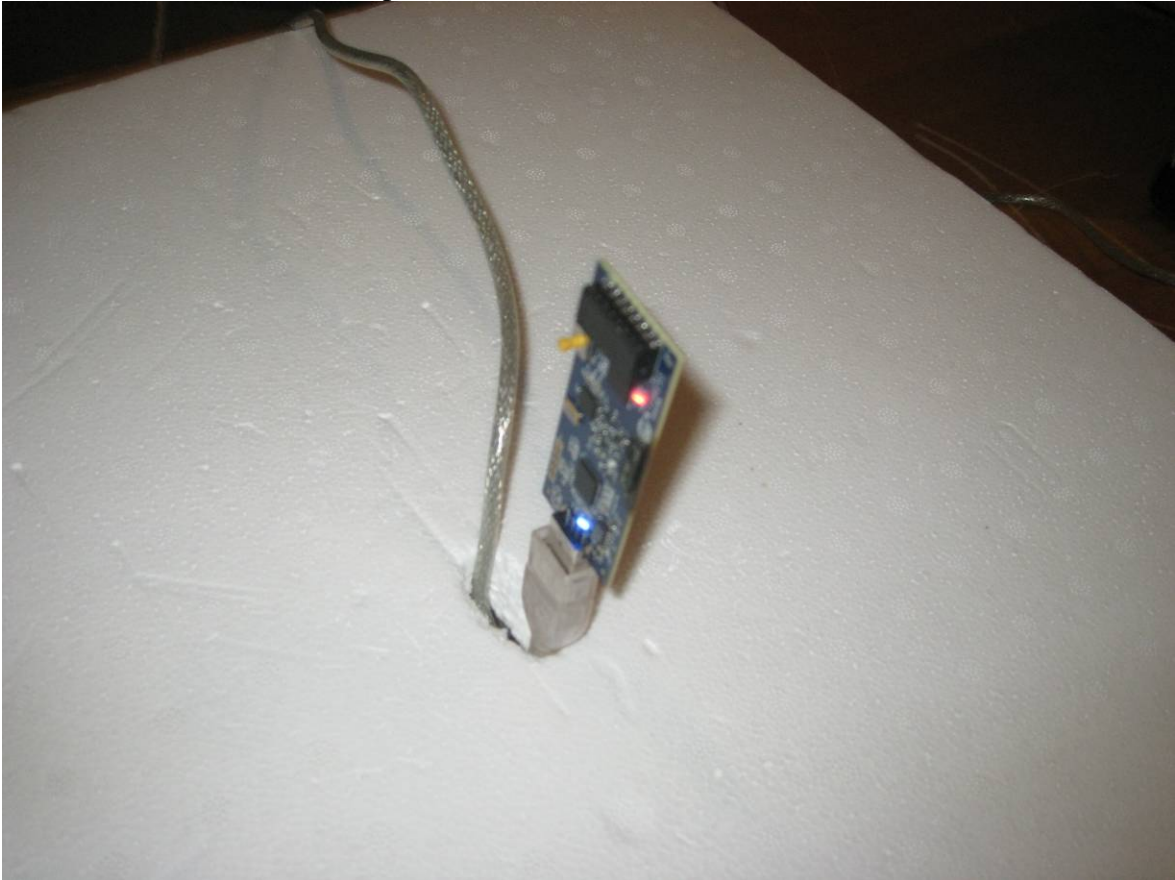

Client	Cypress	
Product	CY3271 FirstTouch RF Bridge	
Standard(s)	RSS 210 Issue 7:2007 / FCC Part 15 Subpart C 15:2008	

Antenna port conducted emissions test setup

