FCC Test Report

Report No.: AGC00797150901FE03

FCC ID : WAD-BTR020
APPLICATION PURPOSE : Original Equipment
PRODUCT DESIGNATION : Bluetooth HD transmitter and receiver 2 in 1
BRAND NAME : K-mate
MODEL NAME : BTR020N, BTR020
CLIENT : Zhongshan K-mate General Electronics Co., Ltd.
DATE OF ISSUE : Oct.12,2015
STANDARD(S) : FCC Part 15 Rules
TEST PROCEDURE(S)
REPORT VERSION : V1.0

Attestation of Global Compliance (Shenzhen) Co., Ltd



CAUTION:

This report shall not be reproduced except in full without the written permission of the test laboratory and shall not be quoted out of context.



Report Revise Record

| Report Version | Revise Time | Issued Date | Valid Version | Notes |
|----------------|-------------|-------------|---------------|-----------------|
| V1.0 | / | Oct.12,2015 | Valid | Original Report |

TABLE OF CONTENTS

| | |
|---|-----------|
| 1. VERIFICATION OF CONFORMITY | 4 |
| 2. GENERAL INFORMATION | 5 |
| 2.1. PRODUCT DESCRIPTION..... | 5 |
| 2.2. TABLE OF CARRIER FREQUENCYS..... | 5 |
| 3. MEASUREMENT UNCERTAINTY..... | 7 |
| 4. DESCRIPTION OF TEST MODES..... | 7 |
| 5. SYSTEM TEST CONFIGURATION | 8 |
| 5.1. CONFIGURATION OF EUT SYSTEM | 8 |
| 5.2. EQUIPMENT USED IN EUT SYSTEM | 8 |
| 5.3. SUMMARY OF TEST RESULTS | 8 |
| 6. TEST FACILITY | 9 |
| 7 ALL TEST EQUIPMENT LIST | 9 |
| 8. RADIATED EMISSION | 10 |
| 8.1TEST LIMIT..... | 10 |
| 8.2. MEASUREMENT PROCEDURE | 11 |
| 8.3. TEST SETUP..... | 13 |
| 8.4. TEST RESULT | 15 |
| 9. BAND EDGE EMISSION | 41 |
| 9.1. MEASUREMENT PROCEDURE | 41 |
| 9.2 TEST SETUP | 41 |
| 9.3 RADIATED TEST RESULT | 42 |
| 10. 20DB BANDWIDTH..... | 50 |
| 10.1. MEASUREMENT PROCEDURE | 50 |
| 10.2. TEST SET-UP | 50 |
| 10.3. LIMITS AND MEASUREMENT RESULTS..... | 50 |
| 11. FCC LINE CONDUCTED EMISSION TEST | 59 |
| 11.1. LIMITS OF LINE CONDUCTED EMISSION TEST | 59 |
| 11.2. BLOCK DIAGRAM OF LINE CONDUCTED EMISSION TEST..... | 59 |
| 11.3. PRELIMINARY PROCEDURE OF LINE CONDUCTED EMISSION TEST | 60 |
| 11.4. FINAL PROCEDURE OF LINE CONDUCTED EMISSION TEST..... | 60 |
| 11.5. TEST RESULT OF LINE CONDUCTED EMISSION TEST..... | 61 |
| APPENDIX A: PHOTOGRAPHS OF TEST SETUP | 65 |
| APPENDIX B: PHOTOGRAPHS OF EUT | 67 |

1. VERIFICATION OF CONFORMITY

| | |
|---------------------------------|---|
| Applicant | Zhongshan K-mate General Electronics Co., Ltd. |
| Address | NO.2, 5th Xinsheng Street, Gangkou Town, Zhongshan City, Guangdong, China |
| Manufacturer | Zhongshan K-mate General Electronics Co., Ltd. |
| Address | NO.2, 5th Xinsheng Street, Gangkou Town, Zhongshan City, Guangdong, China |
| Product Designation | Bluetooth HD transmitter and receiver 2 in 1 |
| Brand Name | K-mate |
| Test Model | BTR020N |
| Series Model | BTR020 |
| Difference description | All the same except for BTR020N support NFC function |
| Date of test | Sep.30,2015 |
| Deviation | None |
| Condition of Test Sample | Normal |
| Report Template | AGCRT-US-BR/RF |

We hereby certify that:

The above equipment was tested by Compliance Certification Service (Shenzhen) Inc. The test data, data evaluation, test procedures, and equipment configurations shown in this report were made in accordance with the procedures given in ANSI C63.4 (2009) and the energy emitted by the sample EUT tested as described in this report is in compliance with radiated emission limits of FCC Rules Part 15.249.

Tested By 
Time Huang(Huang Nanhui) Oct.12,2015

Reviewed By 
Forrest Lei(Lei Yonggang) Oct.12,2015

Approved By 
Solger Zhang(Zhang Hongyi)
Authorized Officer Oct.12,2015

2. GENERAL INFORMATION

2.1. PRODUCT DESCRIPTION

A major technical description of EUT is described as following

| | |
|--|--|
| Operation Frequency | 2.402 GHz to 2.480GHz |
| RF Output Power | 3.77dBm(Max) |
| Bluetooth Version | V4.1 |
| Modulation | GFSK, π /4-DQPSK, 8DPSK |
| Number of channels | 79 for BR/EDR 40 for BLE |
| Hardware Version | V1.0 |
| Software Version | V1.0 |
| Antenna Designation | PCB Antenna (Met 15.203 Antenna requirement) |
| Antenna Gain | 0dBi |
| Power Supply | DC 5V by USB |
| <p>Note: The USB port only for charging and can't be used to transfer data with PC. The EUT Supports NFC function, but NFC tag is passive.</p> | |

2.2. TABLE OF CARRIER FREQUENCIES

BR/EDR Bluetooth channel List

| Frequency Band | Channel Number | Frequency |
|----------------|----------------|-----------|
| 2400~2483.5MHZ | 0 | 2402MHZ |
| | 1 | 2403MHZ |
| | : | : |
| | 38 | 2440 MHZ |
| | 39 | 2441 MHZ |
| | 40 | 2442 MHZ |
| | : | : |
| | 77 | 2479 MHZ |
| | 78 | 2480 MHZ |

BLE Channel List

| Frequency Band | Channel Number | Frequency |
|----------------|----------------|-----------|
| 2400~2483.5MHZ | 0 | 2402MHZ |
| | 1 | 2404MHZ |
| | : | : |
| | 38 | 2478 MHZ |
| | 39 | 2480 MHZ |

3. MEASUREMENT UNCERTAINTY

The reported uncertainty of measurement $y \pm U$, where expanded uncertainty U is based on a standard uncertainty multiplied by a coverage factor of $k=2$, providing a level of confidence of approximately 95 %.

| No. | Item | Uncertainty |
|-----|-------------------------|-------------------------|
| 1 | Conducted Emission Test | $\pm 3.18\text{dB}$ |
| 2 | All emissions, radiated | $\pm 3.91\text{dB}$ |
| 3 | Temperature | $\pm 0.5^\circ\text{C}$ |
| 4 | Humidity | $\pm 2\%$ |

4. DESCRIPTION OF TEST MODES

| NO. | TEST MODE DESCRIPTION |
|---|-------------------------------|
| 1 | Low channel GFSK |
| 2 | Middle channel GFSK |
| 3 | High channel GFSK |
| 4 | Low channel $\pi/4$ -DQPSK |
| 5 | Middle channel $\pi/4$ -DQPSK |
| 6 | High channel $\pi/4$ -DQPSK |
| 7 | Low channel 8DPSK |
| 8 | Middle channel 8DPSK |
| 9 | High channel 8DPSK |
| 10 | Normal operation (BT) |
| Note: 1.The EUT used fully-charged battery when tested. | |

5. SYSTEM TEST CONFIGURATION

5.1. CONFIGURATION OF EUT SYSTEM

Configure 1: (Normal hopping)



Configure 2: (Control continuous TX)

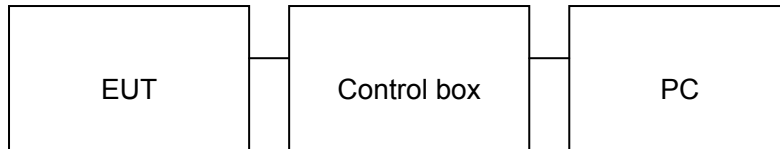

5.2. EQUIPMENT USED IN EUT SYSTEM

| Item | Equipment | Model No. | ID or Specification | Remark |
|------|--|-----------|---------------------|--------|
| 1 | Bluetooth HD transmitter and receiver 2 in 1 | K-mate | BTR020N | EUT |
| 2 | PC | Lenovo | SL410K | A.E |
| 3 | Control box | N/A | N/A | A.E |
| 4 | USB Cable | N/A | 1.3m, unshielded | A.E |
| 5 | Audio Cable | N/A | 0.7m, unshielded | A.E |
| 6 | IPOD | APPLE | A1367 | A.E |
| 7 | Earphone | N/A | L5 | A.E |

5.3. SUMMARY OF TEST RESULTS

| FCC RULES | DESCRIPTION OF TEST | RESULT |
|-----------|---------------------|-----------|
| §15.249 | Radiated Emission | Compliant |
| §15.249 | Band Edges | Compliant |
| §15.207 | Conduction Emission | Compliant |
| N/A | BANDWIDTH | Compliant |

6. TEST FACILITY

| | |
|-----------------------------|--|
| Site | Compliance Certification Service(Shenzhen) Inc. |
| Location | No.10-1 Mingkeda Logistics Park, No.18 Huanguan South RD. Guan lan Town,Baoan Distr |
| FCC Registration No. | 441872 |
| Description | The test site is constructed and calibrated to meet the FCC requirements in documents ANSI C63.4:2009. |

7 ALL TEST EQUIPMENT LIST

| Radiated Emission Test Site 966(2) | | | | | |
|---|---------------------|---------------------|----------------------|-------------------------|------------------------|
| Name of Equipment | Manufacturer | Model Number | Serial Number | Last Calibration | Due Calibration |
| PSA Series Spectrum Analyzer | Agilent | E4446A | US44300399 | 03/01/2015 | 03/01/2016 |
| EMI TEST RECEIVER | ROHDE&SCHWARZ | ESCI | 100783 | 03/09/2015 | 03/08/2016 |
| Amplifier | MITEQ | AM-1604-3000 | 1123808 | 03/18/2015 | 03/17/2016 |
| High Noise Amplifier | Agilent | 8449B | 3008A01838 | 03/18/2015 | 03/17/2016 |
| Board-Band Horn Antenna | Schwarzbeck | BBHA 9170 | 9170-497 | 07/10/2015 | 07/09/2016 |
| Bilog Antenna | SCHAFFNER | CBL6143 | 5082 | 03/01/2015 | 03/01/2016 |
| Horn Antenna | SCHWARZBECK | BBHA9120 | D286 | 03/01/2015 | 03/01/2016 |
| Loop Antenna | COM-POWER | AL-130 | 121044 | 09/27/2014 | 09/26/2015 |
| Turn Table | N/A | N/A | N/A | N.C.R | N.C.R |
| Controller | Sunol Sciences | SC104V | 022310-1 | N.C.R | N.C.R |
| Controller | CT | N/A | N/A | N.C.R | N.C.R |
| Temp. / Humidity Meter | Anymetre | JR913 | N/A | 02/28/2015 | 02/27/2016 |
| Antenna Tower | SUNOL | TLT2 | N/A | N.C.R | N.C.R |
| Test S/W | FARAD | LZ-RF / CCS-SZ-3A2 | | | |

| Conducted Emission Test Site | | | | | |
|-------------------------------------|---------------------|---------------------|----------------------|-------------------------|------------------------|
| Name of Equipment | Manufacturer | Model Number | Serial Number | Last Calibration | Due Calibration |
| EMI TEST RECEIVER | ROHDE&SCHWARZ | ESCI | 100783 | 03/09/2015 | 03/08/2016 |
| LISN(EUT) | ROHDE&SCHWARZ | ENV216 | 101543-WX | 03/09/2015 | 03/08/2016 |
| LISN | EMCO | 3825/2 | 8901-1459 | 03/09/2015 | 03/08/2016 |
| Temp. / Humidity Meter | VICTOR | HTC-1 | N/A | 03/04/2015 | 03/03/2016 |
| Test S/W | FARAD | EZ-EMC/ CCS-3A1-CE | | | |

8. RADIATED EMISSION

8.1 TEST LIMIT

Standard FCC15.249

| Fundamental Frequency | Field Strength of Fundamental (millivolts/meter) | Field Strength of Harmonics (microvolts/meter) |
|-----------------------|--|--|
| 900-928MHz | 50 | 500 |
| 2400-2483.5MHz | 50 | 500 |
| 5725-5875MHz | 50 | 500 |
| 24.0-24.25GHz | 250 | 2500 |

Standard FCC 15.209

| Frequency (MHz) | Distance Meters | Field Strengths Limit | |
|-----------------|-----------------|--|----------------|
| | | μ V/m | dB(μ V)/m |
| 0.009 ~ 0.490 | 300 | 2400/F(kHz) | --- |
| 0.490 ~ 1.705 | 30 | 24000/F(kHz) | --- |
| 1.705 ~ 30 | 30 | 30 | --- |
| 30 ~ 88 | 3 | 100 | 40.0 |
| 88 ~ 216 | 3 | 150 | 43.5 |
| 216 ~ 960 | 3 | 200 | 46.0 |
| 960 ~ 1000 | 3 | 500 | 54.0 |
| Above 1000 | 3 | Other:74.0 dB(μ V)/m (Peak) 54.0 dB(μ V)/m (Average) | |

Remark: (1) Emission level dB μ V = 20 log Emission level μ V/m
(2) The smaller limit shall apply at the cross point between two frequency bands.
(3) Distance is the distance in meters between the measuring instrument, antenna and the closest point of any part of the device or system.

8.2. MEASUREMENT PROCEDURE

1. Configure the EUT according to ANSI C63.4. The EUT was placed on the top of the turntable 0.8 meter above ground. The phase center of the receiving antenna mounted on the top of a height-variable antenna tower was placed 3 meters far away from the turntable.
2. Power on the EUT and all the supporting units. The turntable was rotated by 360 degrees to determine the position of the highest radiation.
3. The height of the broadband receiving antenna was varied between one meter and four meters above ground to find the maximum emissions field strength of both horizontal and vertical polarization.
4. For each suspected emissions, the antenna tower was scan (from 1 M to 4 M) and then the turntable was rotated (from 0 degree to 360 degrees) to find the maximum reading.
5. Set the test-receiver system to Peak or CISPR quasi-peak Detect Function with specified bandwidth under Maximum Hold Mode.
6. For emissions above 1GHz, use 1.5MHz VBW and RBW for peak reading. Then 1.5MHz RBW and 10Hz VBW for average reading in spectrum analyzer.
7. When the radiated emissions limits are expressed in terms of the average value of the emissions, and pulsed operation is employed, the measurement field strength shall be determined by averaging over one complete pulse train, including blanking intervals, as long as the pulse train does not exceed 0.1 seconds. As an alternative (provided the transmitter operates for longer than 0.1 seconds) or in cases where the pulse train exceeds 0.1 seconds, the measured field strength shall be determined from the average absolute voltage during a 0.1 second interval during which the field strength is at its maximum values.
8. If the emissions level of the EUT in peak mode was 3 dB lower than the average limit specified, then testing will be stopped and peak values of EUT will be reported, otherwise, the emissions which do not have 3 dB margin will be repeated one by one using the quasi-peak method for below 1GHz.
9. For testing above 1GHz, the emissions level of the EUT in peak mode was lower than average limit (that means the emissions level in peak mode also complies with the limit in average mode), then testing will be stopped and peak values of EUT will be reported, otherwise, the emissions will be measured in average mode again and reported.
10. In case the emission is lower than 30MHz, loop antenna has to be used for measurement and the recorded data should be QP measured by receiver. High - Low scan is not required in this case.

The following table is the setting of spectrum analyzer and receiver.

| Spectrum Parameter | Setting |
|---------------------------|---|
| Start ~Stop Frequency | 9KHz~150KHz/RB 200Hz for QP |
| Start ~Stop Frequency | 150KHz~30MHz/RB 9KHz for QP |
| Start ~Stop Frequency | 30MHz~1000MHz/RB 120KHz for QP |
| Start ~Stop Frequency | 1GHz~26.5GHz 1.5MHz/1.5MHz for Peak, 1.5MHz/10Hz for Average |

| Receiver Parameter | Setting |
|---------------------------|--------------------------------|
| Start ~Stop Frequency | 9KHz~150KHz/RB 200Hz for QP |
| Start ~Stop Frequency | 150KHz~30MHz/RB 9KHz for QP |
| Start ~Stop Frequency | 30MHz~1000MHz/RB 120KHz for QP |

8.3. TEST SETUP

Radiated Emission Test-Setup Frequency Below 30MHz

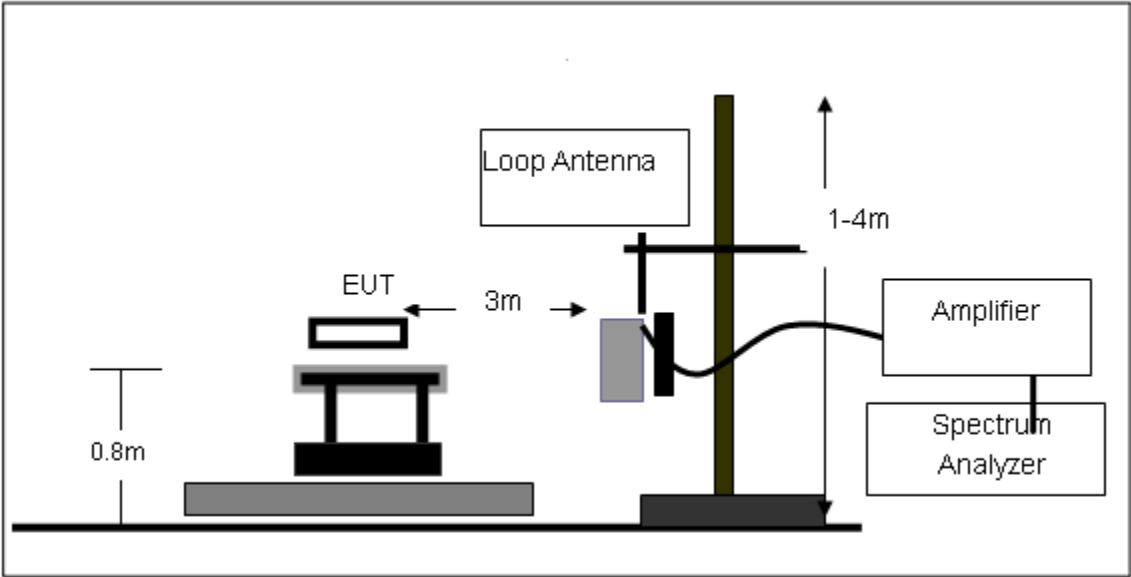

RADIATED EMISSION TEST SETUP 30MHz-1000MHz

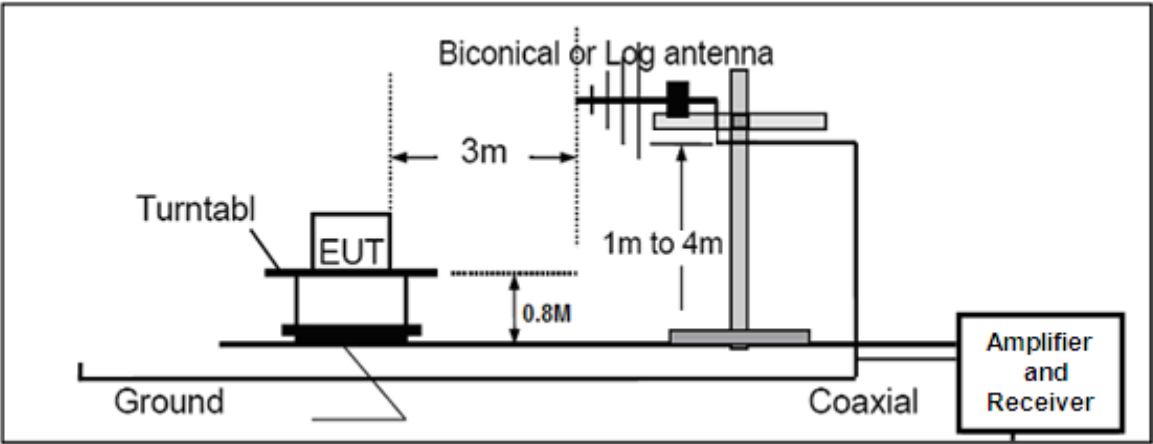

RADIATED EMISSION TEST SETUP ABOVE 1000MHz

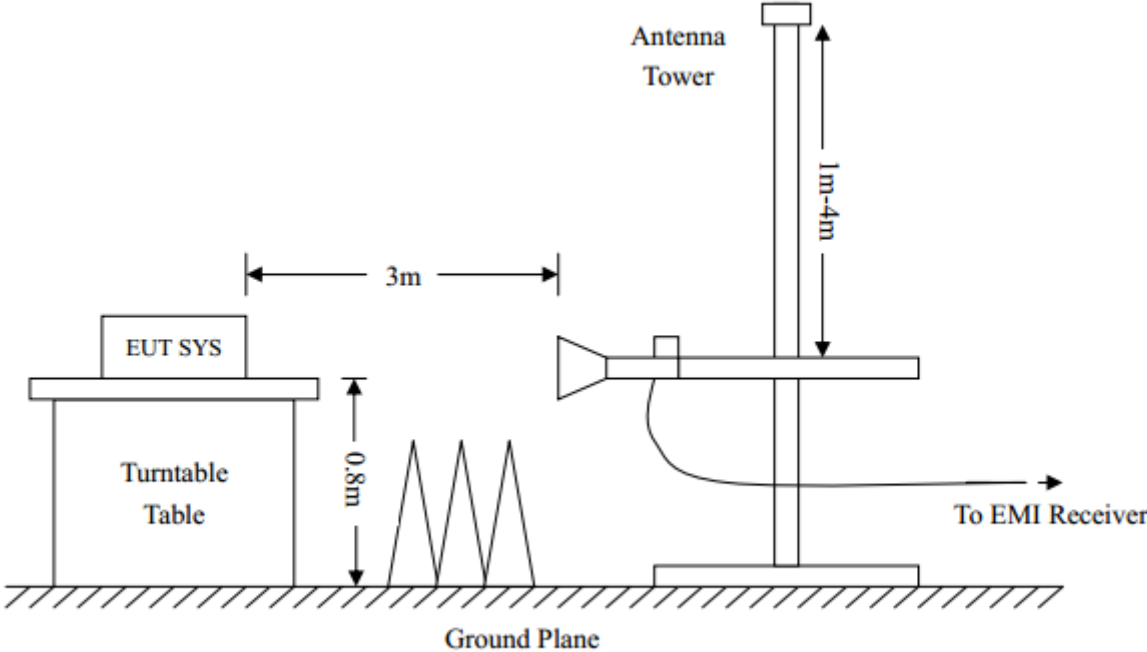

8.4. TEST RESULT

**(Worst modulation: GFSK)
 FOR BR/EDR BLUETOOTH**

RADIATED EMISSION BELOW 30MHZ

No emission found between lowest internal used/generated frequencies to 30MHz.

RADIATED EMISSION BELOW 1GHZ

RADIATED EMISSION TEST- (30MHZ-1GHZ)-LOW CHANNEL-HORIZONTAL

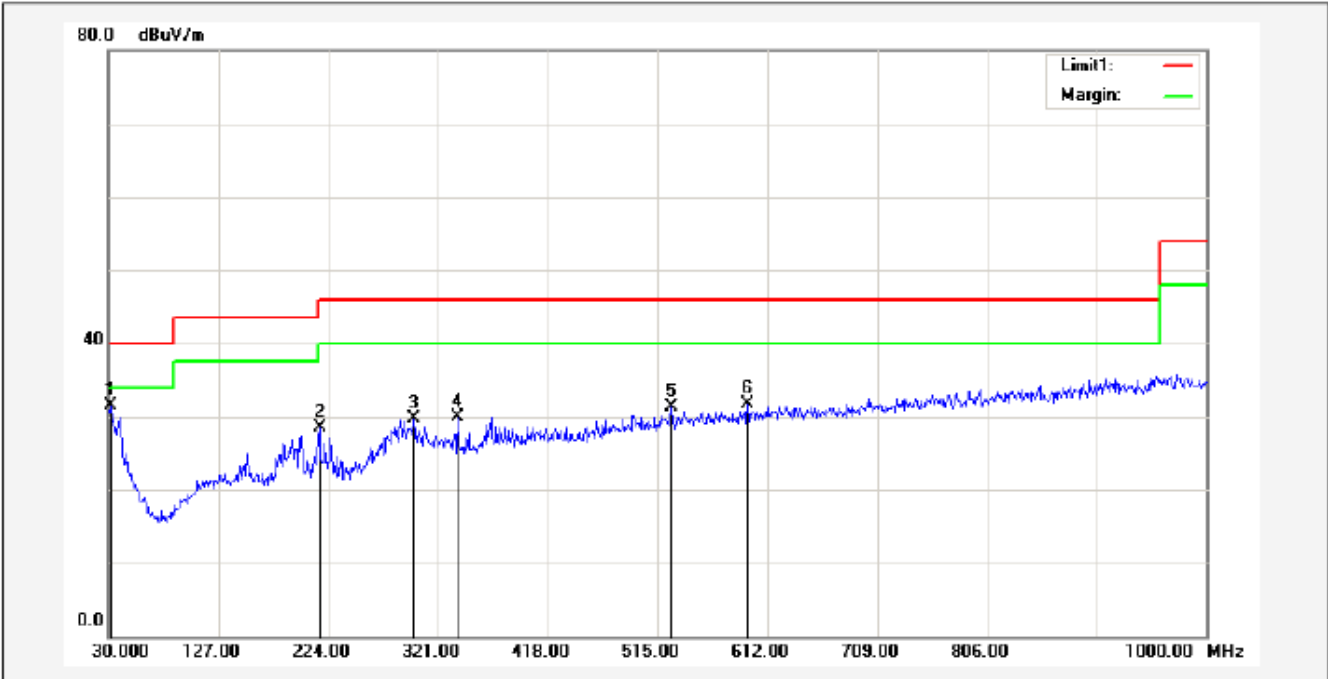

| No. | Frequency (MHz) | Reading (dBuV) | Correction factor(dB/m) | Result (dBuV/m) | Limit (dBuV/m) | Margin (dB) | Degree (deg.) | Height (cm) | Remark |
|-----|-----------------|----------------|-------------------------|-----------------|----------------|-------------|---------------|-------------|--------|
| 1* | 31.9400 | 44.39 | -12.80 | 31.59 | 40.00 | -8.41 | | | peak |
| 2 | 216.2400 | 49.37 | -20.79 | 28.58 | 46.00 | -17.42 | | | peak |
| 3 | 299.6600 | 49.38 | -19.60 | 29.78 | 46.00 | -16.22 | | | peak |
| 4 | 338.4600 | 48.17 | -18.19 | 29.98 | 46.00 | -16.02 | | | peak |
| 5 | 526.6400 | 45.20 | -13.97 | 31.23 | 46.00 | -14.77 | | | peak |
| 6 | 594.5400 | 44.75 | -12.96 | 31.79 | 46.00 | -14.21 | | | peak |

RESULT: PASS

RADIATED EMISSION TEST- (30MHZ-1GHZ)-LOW CHANNEL -VERTICAL

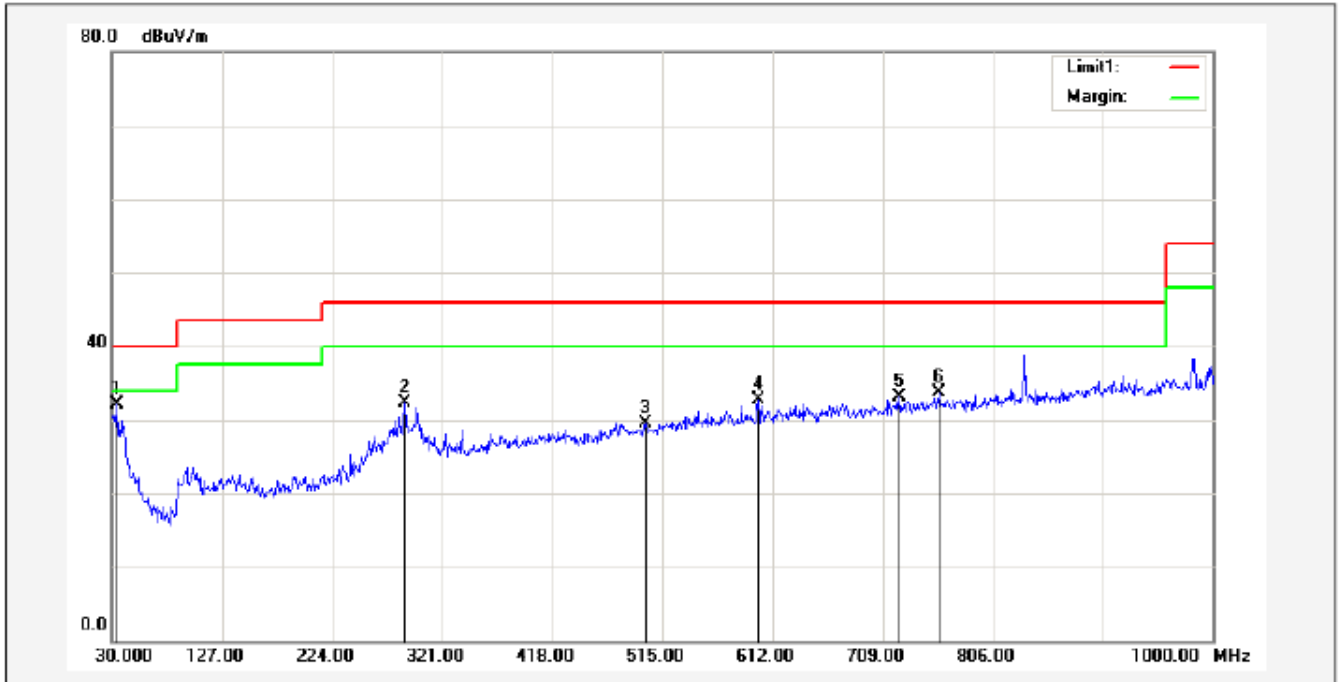

| No. | Frequency (MHz) | Reading (dBuV) | Correction factor(dB/m) | Result (dBuV/m) | Limit (dBuV/m) | Margin (dB) | Degree (deg.) | Height (cm) | Remark |
|-----|-----------------|----------------|-------------------------|-----------------|----------------|-------------|---------------|-------------|--------|
| 1* | 33.8800 | 46.17 | -14.06 | 32.11 | 40.00 | -7.89 | | | peak |
| 2 | 288.0200 | 52.81 | -20.45 | 32.36 | 46.00 | -13.64 | | | peak |
| 3 | 499.4800 | 43.80 | -14.36 | 29.44 | 46.00 | -16.56 | | | peak |
| 4 | 599.3900 | 45.59 | -12.88 | 32.71 | 46.00 | -13.29 | | | peak |
| 5 | 723.5500 | 44.80 | -11.77 | 33.03 | 46.00 | -12.97 | | | peak |
| 6 | 758.4700 | 44.68 | -11.05 | 33.63 | 46.00 | -12.37 | | | peak |

RESULT: PASS

Note: 1. Factor=Antenna Factor + Cable loss, Margin=Measurement-Limit.

2. The "Factor" value can be calculated automatically by software of measurement system.

RADIATED EMISSION TEST- (30MHZ-1GHZ)-MIDDLE CHANNEL-HORIZONTAL

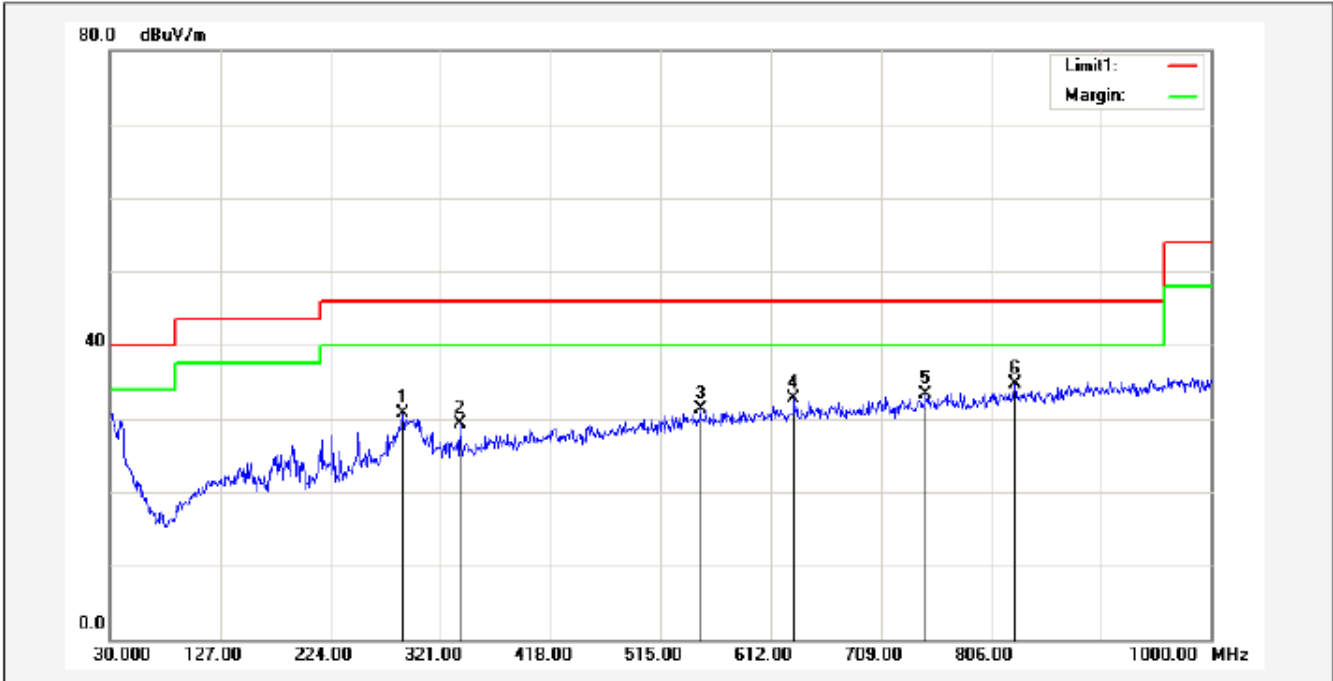

| No. | Frequency (MHz) | Reading (dBuV) | Correction factor(dB/m) | Result (dBuV/m) | Limit (dBuV/m) | Margin (dB) | Degree (deg.) | Height (cm) | Remark |
|-----|-----------------|----------------|-------------------------|-----------------|----------------|-------------|---------------|-------------|--------|
| 1 | 288.0200 | 51.22 | -20.45 | 30.77 | 46.00 | -15.23 | | | peak |
| 2 | 338.4600 | 47.57 | -18.19 | 29.38 | 46.00 | -16.62 | | | peak |
| 3 | 549.9200 | 44.41 | -13.10 | 31.31 | 46.00 | -14.69 | | | peak |
| 4 | 632.3700 | 45.13 | -12.49 | 32.64 | 46.00 | -13.36 | | | peak |
| 5 | 748.7700 | 44.43 | -11.21 | 33.22 | 46.00 | -12.78 | | | peak |
| 6* | 827.3400 | 45.19 | -10.53 | 34.66 | 46.00 | -11.34 | | | peak |

RESULT: PASS

RADIATED EMISSION TEST- (30MHZ-1GHZ)- MIDDLE CHANNEL -VERTICAL

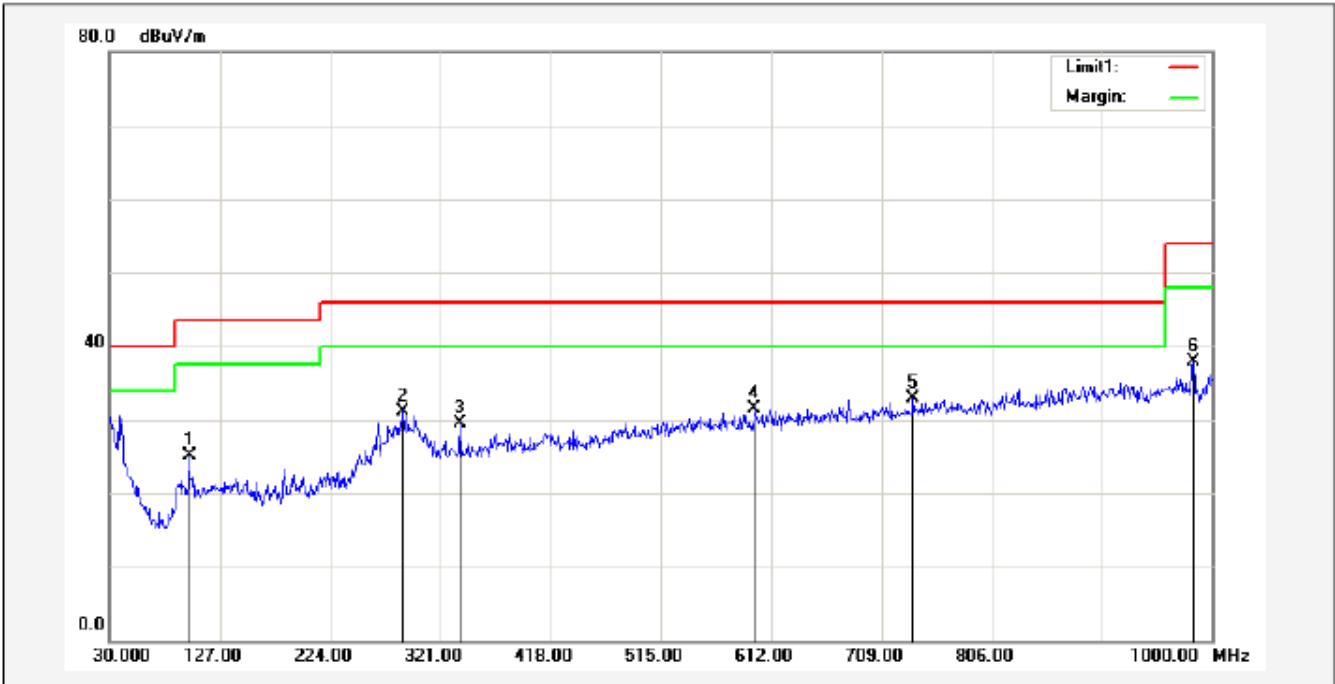

| No. | Frequency (MHz) | Reading (dBuV) | Correction factor(dB/m) | Result (dBuV/m) | Limit (dBuV/m) | Margin (dB) | Degree (deg.) | Height (cm) | Remark |
|-----|-----------------|----------------|-------------------------|-----------------|----------------|-------------|---------------|-------------|--------|
| 1 | 99.8400 | 48.81 | -23.70 | 25.11 | 43.50 | -18.39 | | | peak |
| 2 | 288.0200 | 51.51 | -20.45 | 31.06 | 46.00 | -14.94 | | | peak |
| 3 | 338.4600 | 47.66 | -18.19 | 29.47 | 46.00 | -16.53 | | | peak |
| 4 | 597.4500 | 44.38 | -12.91 | 31.47 | 46.00 | -14.53 | | | peak |
| 5* | 737.1300 | 44.29 | -11.42 | 32.87 | 46.00 | -13.13 | | | peak |
| 6 | 983.5100 | 47.12 | -9.24 | 37.88 | 54.00 | -16.12 | | | peak |

RESULT: PASS

Note: 1. Factor=Antenna Factor + Cable loss, Margin=Measurement-Limit.

2. The "Factor" value can be calculated automatically by software of measurement system.

RADIATED EMISSION TEST- (30MHZ-1GHZ)-HIGH CHANNEL-HORIZONTAL

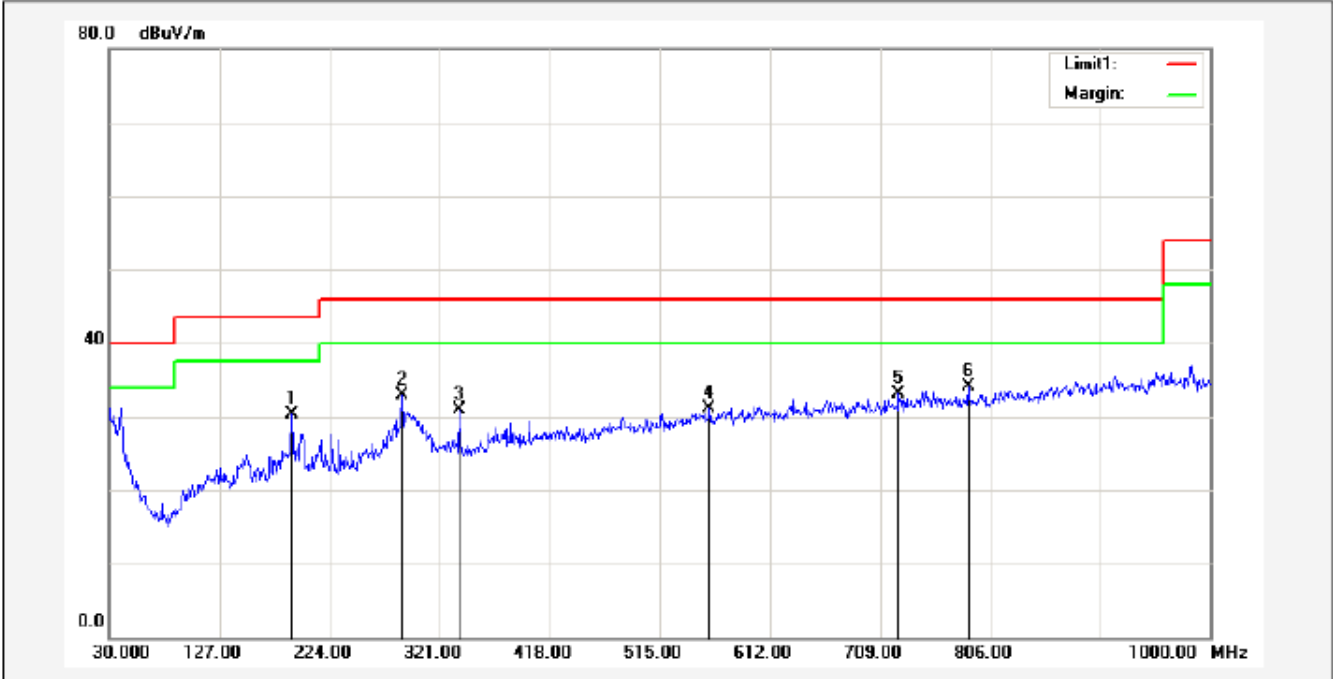

| No. | Frequency (MHz) | Reading (dBuV) | Correction factor(dB/m) | Result (dBuV/m) | Limit (dBuV/m) | Margin (dB) | Degree (deg.) | Height (cm) | Remark |
|-----|-----------------|----------------|-------------------------|-----------------|----------------|-------------|---------------|-------------|--------|
| 1 | 191.0200 | 53.07 | -22.85 | 30.22 | 43.50 | -13.28 | | | peak |
| 2 | 288.0200 | 53.28 | -20.45 | 32.83 | 46.00 | -13.17 | | | peak |
| 3 | 338.4600 | 49.00 | -18.19 | 30.81 | 46.00 | -15.19 | | | peak |
| 4 | 558.6500 | 44.27 | -13.24 | 31.03 | 46.00 | -14.97 | | | peak |
| 5 | 725.4900 | 44.87 | -11.72 | 33.15 | 46.00 | -12.85 | | | peak |
| 6* | 786.6000 | 45.33 | -11.19 | 34.14 | 46.00 | -11.86 | | | peak |

RESULT: PASS

RADIATED EMISSION TEST- (30MHZ-1GHZ)-HIGH CHANNEL -VERTICAL

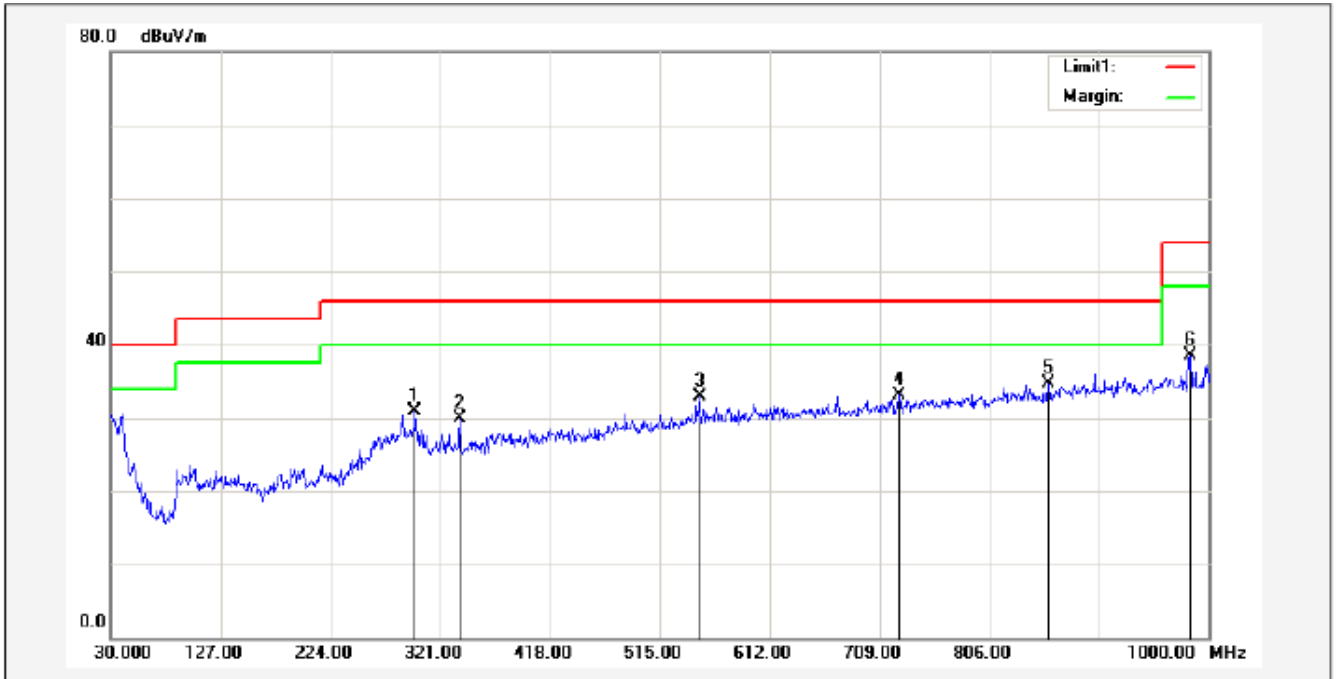

| No. | Frequency (MHz) | Reading (dBuV) | Correction factor(dB/m) | Result (dBuV/m) | Limit (dBuV/m) | Margin (dB) | Degree (deg.) | Height (cm) | Remark |
|-----|-----------------|----------------|-------------------------|-----------------|----------------|-------------|---------------|-------------|--------|
| 1 | 298.6900 | 50.62 | -19.69 | 30.93 | 46.00 | -15.07 | | | peak |
| 2 | 338.4600 | 48.04 | -18.19 | 29.85 | 46.00 | -16.15 | | | peak |
| 3 | 549.9200 | 45.92 | -13.10 | 32.82 | 46.00 | -13.18 | | | peak |
| 4 | 726.4600 | 44.74 | -11.70 | 33.04 | 46.00 | -12.96 | | | peak |
| 5* | 858.3800 | 45.34 | -10.64 | 34.70 | 46.00 | -11.30 | | | peak |
| 6 | 983.5100 | 47.82 | -9.24 | 38.58 | 54.00 | -15.42 | | | peak |

RESULT: PASS

Note: 1. Factor=Antenna Factor + Cable loss, Margin=Measurement-Limit.

2. The "Factor" value can be calculated automatically by software of measurement system.

FOR BLE

RADIATED EMISSION BELOW 30MHZ

No emission found between lowest internal used/generated frequencies to 30MHz.

RADIATED EMISSION BELOW 1GHZ

RADIATED EMISSION TEST- (30MHZ-1GHZ)-LOW CHANNEL-HORIZONTAL

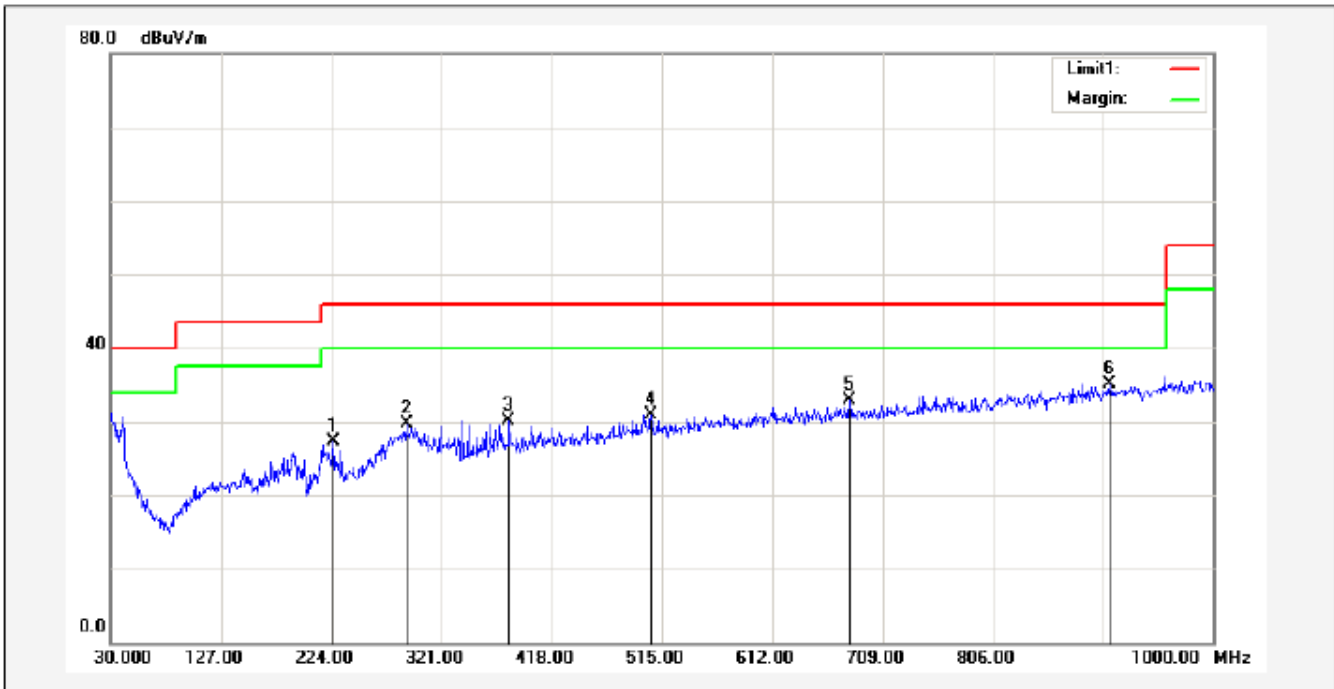

| No. | Frequency (MHz) | Reading (dBuV) | Correction factor(dB/m) | Result (dBuV/m) | Limit (dBuV/m) | Margin (dB) | Degree (deg.) | Height (cm) | Remark |
|-----|-----------------|----------------|-------------------------|-----------------|----------------|-------------|---------------|-------------|--------|
| 1 | 225.9400 | 48.53 | -21.24 | 27.29 | 46.00 | -18.71 | | | peak |
| 2 | 289.9600 | 50.14 | -20.47 | 29.67 | 46.00 | -16.33 | | | peak |
| 3 | 380.1700 | 46.61 | -16.46 | 30.15 | 46.00 | -15.85 | | | peak |
| 4 | 505.3000 | 45.20 | -14.30 | 30.90 | 46.00 | -15.10 | | | peak |
| 5 | 679.9000 | 45.35 | -12.44 | 32.91 | 46.00 | -13.09 | | | peak |
| 6* | 908.8200 | 44.77 | -9.62 | 35.15 | 46.00 | -10.85 | | | peak |

RESULT: PASS

RADIATED EMISSION TEST- (30MHZ-1GHZ)-LOW CHANNEL -VERTICAL

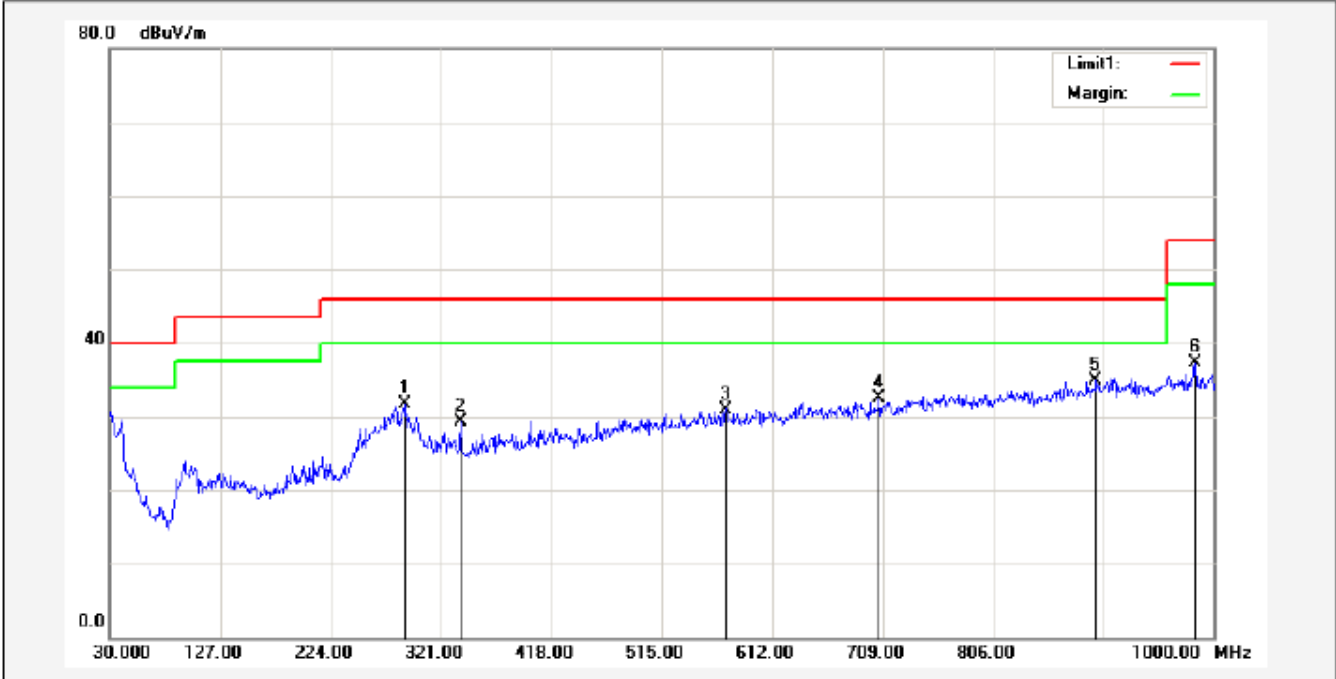

| No. | Frequency (MHz) | Reading (dBuV) | Correction factor(dB/m) | Result (dBuV/m) | Limit (dBuV/m) | Margin (dB) | Degree (deg.) | Height (cm) | Remark |
|-----|-----------------|----------------|-------------------------|-----------------|----------------|-------------|---------------|-------------|--------|
| 1 | 288.9900 | 52.14 | -20.46 | 31.68 | 46.00 | -14.32 | | | peak |
| 2 | 338.4600 | 47.58 | -18.19 | 29.39 | 46.00 | -16.61 | | | peak |
| 3 | 571.2600 | 44.03 | -13.03 | 31.00 | 46.00 | -15.00 | | | peak |
| 4 | 706.0900 | 44.38 | -11.92 | 32.46 | 46.00 | -13.54 | | | peak |
| 5* | 896.2100 | 44.85 | -9.86 | 34.99 | 46.00 | -11.01 | | | peak |
| 6 | 983.5100 | 46.56 | -9.24 | 37.32 | 54.00 | -16.68 | | | peak |

RESULT: PASS

Note: 1. Factor=Antenna Factor + Cable loss, Margin=Measurement-Limit.

2. The "Factor" value can be calculated automatically by software of measurement system.

RADIATED EMISSION TEST- (30MHZ-1GHZ)-MIDDLE CHANNEL-HORIZONTAL

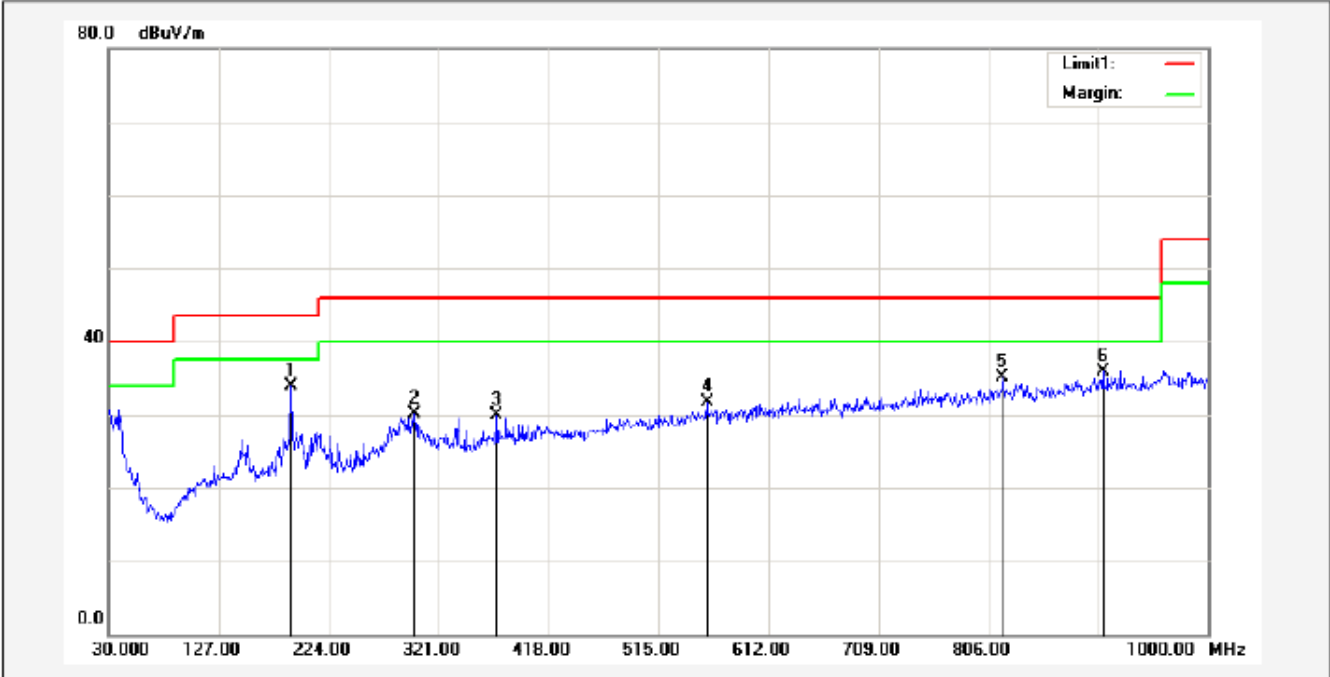

| No. | Frequency (MHz) | Reading (dBuV) | Correction factor(dB/m) | Result (dBuV/m) | Limit (dBuV/m) | Margin (dB) | Degree (deg.) | Height (cm) | Remark |
|-----|-----------------|----------------|-------------------------|-----------------|----------------|-------------|---------------|-------------|--------|
| 1* | 191.0200 | 56.76 | -22.85 | 33.91 | 43.50 | -9.59 | | | peak |
| 2 | 299.6600 | 49.69 | -19.60 | 30.09 | 46.00 | -15.91 | | | peak |
| 3 | 372.4100 | 46.92 | -17.04 | 29.88 | 46.00 | -16.12 | | | peak |
| 4 | 557.6800 | 44.83 | -13.22 | 31.61 | 46.00 | -14.39 | | | peak |
| 5 | 818.6100 | 45.54 | -10.45 | 35.09 | 46.00 | -10.91 | | | peak |
| 6 | 906.8800 | 45.55 | -9.66 | 35.89 | 46.00 | -10.11 | | | peak |

RESULT: PASS

RADIATED EMISSION TEST- (30MHZ-1GHZ)- MIDDLE CHANNEL -VERTICAL

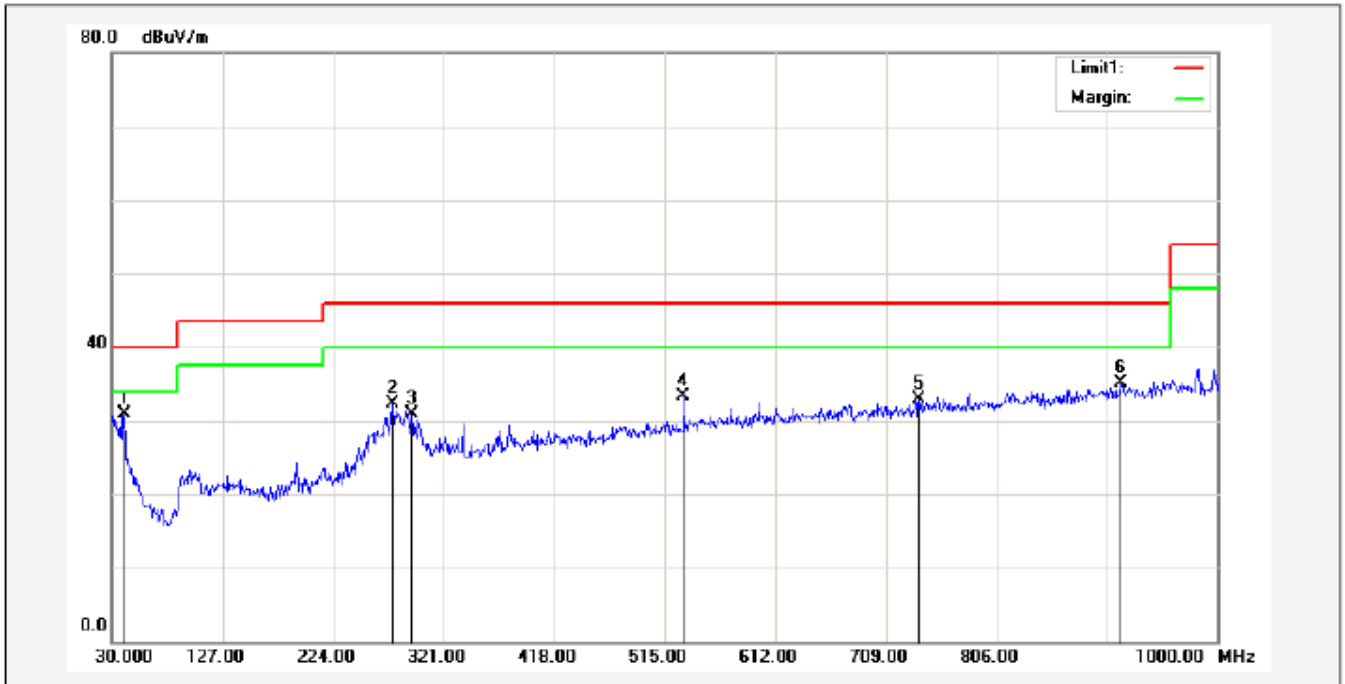

| No. | Frequency (MHz) | Reading (dBuV) | Correction factor(dB/m) | Result (dBuV/m) | Limit (dBuV/m) | Margin (dB) | Degree (deg.) | Height (cm) | Remark |
|-----|-----------------|----------------|-------------------------|-----------------|----------------|-------------|---------------|-------------|--------|
| 1* | 40.6700 | 47.61 | -16.69 | 30.92 | 40.00 | -9.08 | | | peak |
| 2 | 276.3800 | 52.66 | -20.43 | 32.23 | 46.00 | -13.77 | | | peak |
| 3 | 292.8700 | 51.11 | -20.21 | 30.90 | 46.00 | -15.10 | | | peak |
| 4 | 531.4900 | 47.07 | -13.80 | 33.27 | 46.00 | -12.73 | | | peak |
| 5 | 738.1000 | 44.25 | -11.40 | 32.85 | 46.00 | -13.15 | | | peak |
| 6 | 914.6400 | 44.61 | -9.48 | 35.13 | 46.00 | -10.87 | | | peak |

RESULT: PASS

Note: 1. Factor=Antenna Factor + Cable loss, Margin=Measurement-Limit.

2. The "Factor" value can be calculated automatically by software of measurement system.

RADIATED EMISSION TEST- (30MHZ-1GHZ)-HIGH CHANNEL-HORIZONTAL

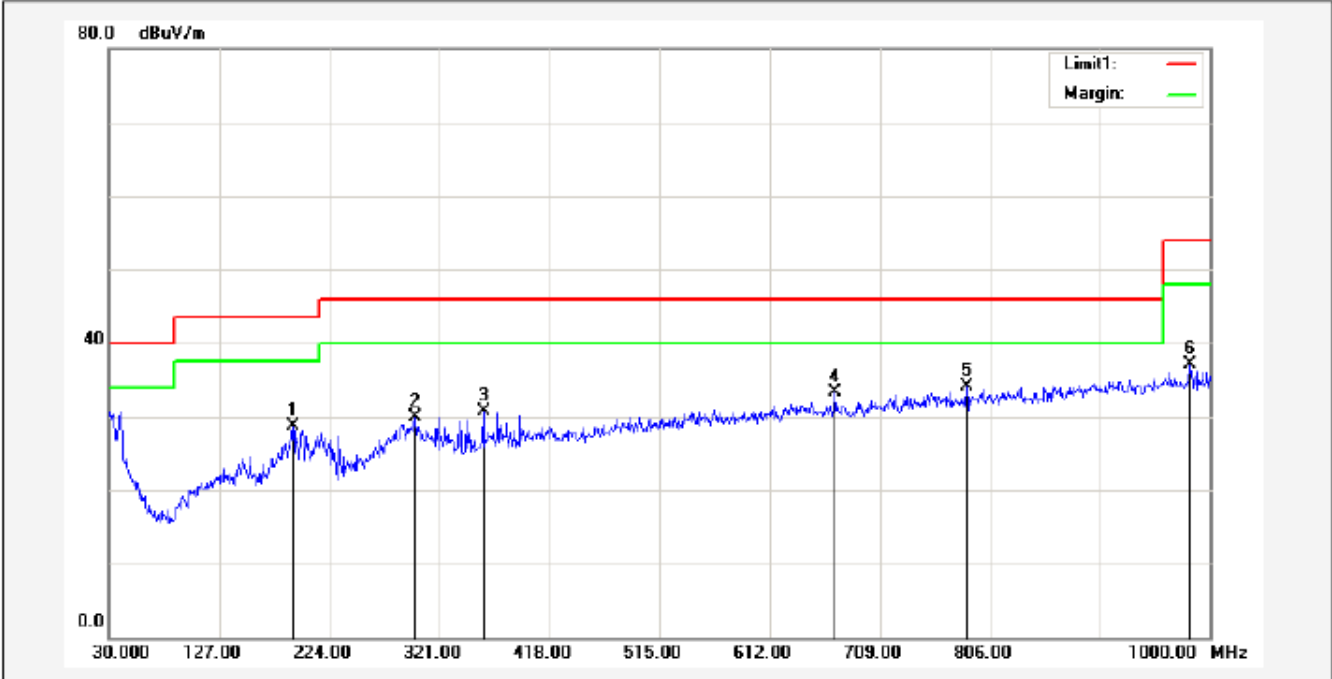

| No. | Frequency (MHz) | Reading (dBuV) | Correction factor(dB/m) | Result (dBuV/m) | Limit (dBuV/m) | Margin (dB) | Degree (deg.) | Height (cm) | Remark |
|-----|-----------------|----------------|-------------------------|-----------------|----------------|-------------|---------------|-------------|--------|
| 1 | 191.9900 | 51.46 | -22.83 | 28.63 | 43.50 | -14.87 | | | peak |
| 2 | 299.6600 | 49.52 | -19.60 | 29.92 | 46.00 | -16.08 | | | peak |
| 3 | 359.8000 | 48.03 | -17.42 | 30.61 | 46.00 | -15.39 | | | peak |
| 4 | 669.2300 | 45.41 | -12.14 | 33.27 | 46.00 | -12.73 | | | peak |
| 5* | 785.6300 | 45.37 | -11.19 | 34.18 | 46.00 | -11.82 | | | peak |
| 6 | 982.5400 | 46.26 | -9.23 | 37.03 | 54.00 | -16.97 | | | peak |

RESULT: PASS

RADIATED EMISSION TEST- (30MHZ-1GHZ)-HIGH CHANNEL -VERTICAL

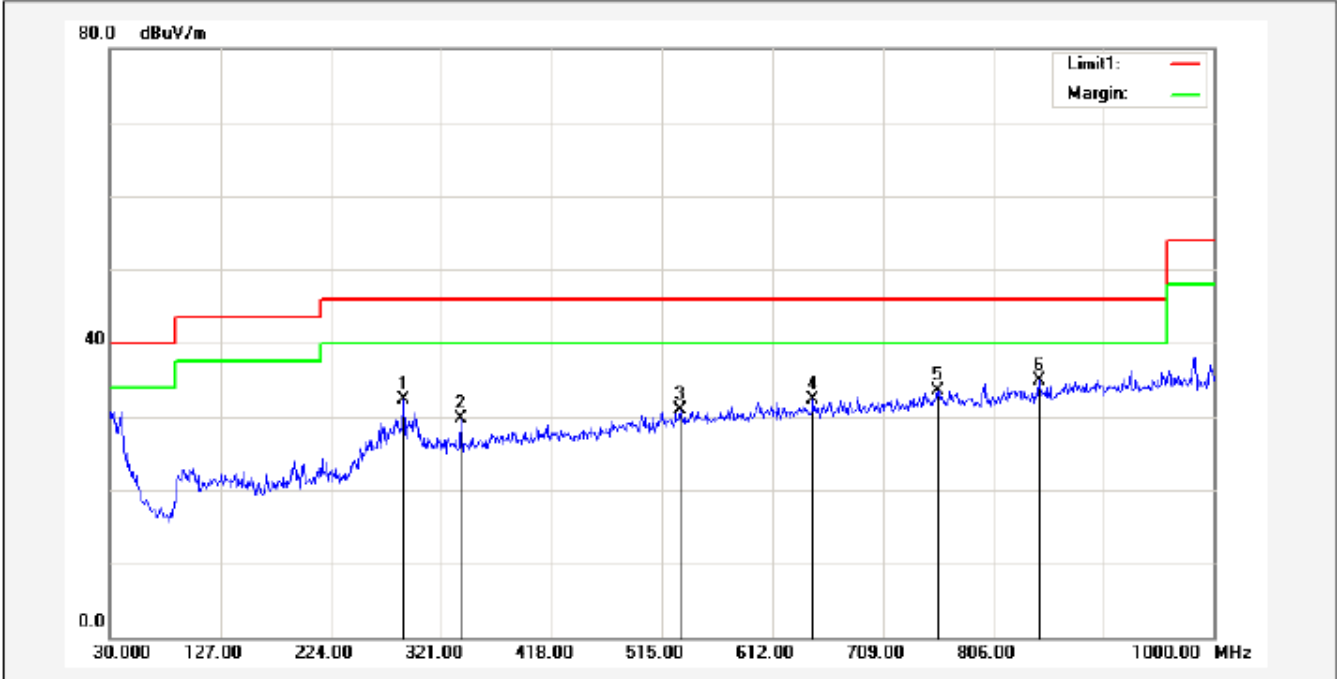

| No. | Frequency (MHz) | Reading (dBuV) | Correction factor(dB/m) | Result (dBuV/m) | Limit (dBuV/m) | Margin (dB) | Degree (deg.) | Height (cm) | Remark |
|-----|-----------------|----------------|-------------------------|-----------------|----------------|-------------|---------------|-------------|--------|
| 1 | 288.0200 | 52.72 | -20.45 | 32.27 | 46.00 | -13.73 | | | peak |
| 2 | 338.4600 | 47.98 | -18.19 | 29.79 | 46.00 | -16.21 | | | peak |
| 3 | 530.5200 | 44.71 | -13.86 | 30.85 | 46.00 | -15.15 | | | peak |
| 4 | 647.8900 | 44.73 | -12.51 | 32.22 | 46.00 | -13.78 | | | peak |
| 5 | 757.5000 | 44.62 | -11.07 | 33.55 | 46.00 | -12.45 | | | peak |
| 6* | 846.7400 | 45.54 | -10.71 | 34.83 | 46.00 | -11.17 | | | peak |

RESULT: PASS

Note: 1. Factor=Antenna Factor + Cable loss, Margin=Measurement-Limit.

2. The “Factor” value can be calculated automatically by software of measurement system.

**RADIATED EMISSION ABOVE 1GHZ
 FOR BR/EDR BLUETOOTH**

RADIATED EMISSION TEST- (ABOVE 1GHZ)-LOW CHANNEL-HORIZONTAL

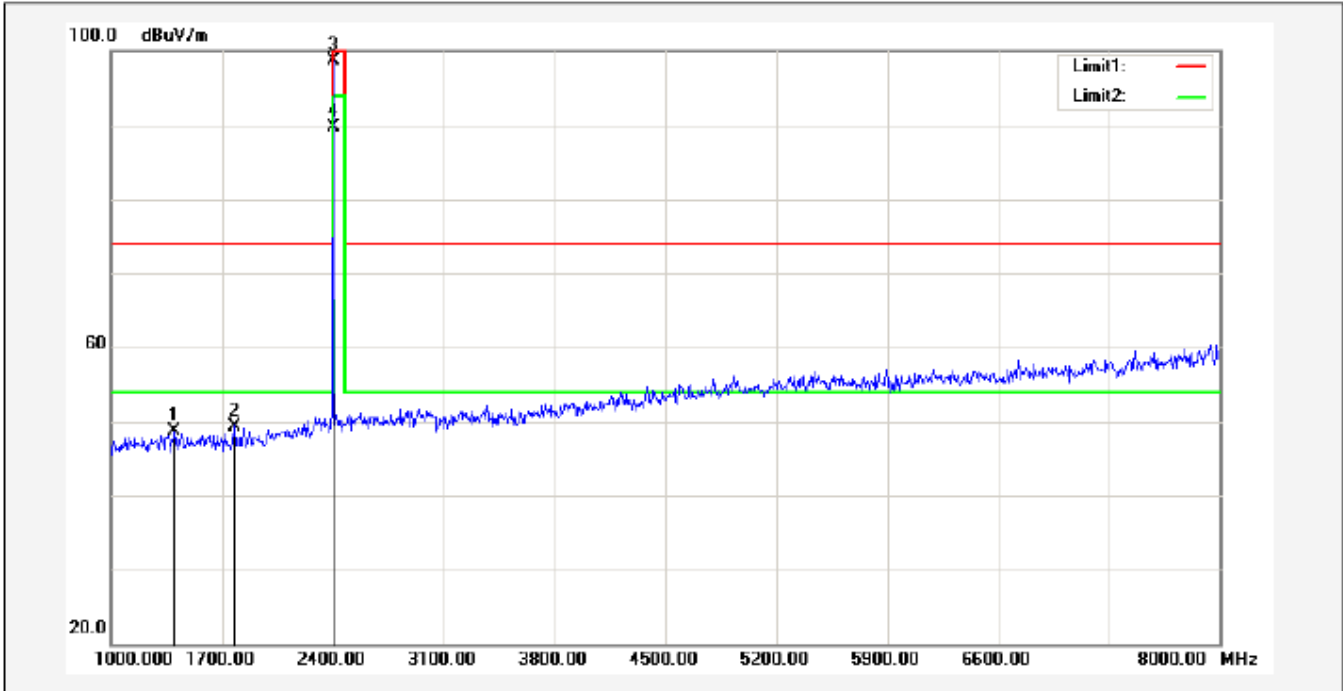

| No. | Frequency (MHz) | Reading (dBuV) | Correction factor(dB/m) | Result (dBuV/m) | Limit (dBuV/m) | Margin (dB) | Degree (deg.) | Height (cm) | Remark |
|-----|-----------------|----------------|-------------------------|-----------------|----------------|-------------|---------------|-------------|--------|
| 1 | 1399.000 | 55.81 | -7.06 | 48.75 | 74.00 | -25.25 | | | peak |
| 2 | 1777.000 | 55.72 | -6.32 | 49.40 | 74.00 | -24.60 | | | peak |
| 3X | 2402.000 | 101.50 | -2.81 | 98.69 | 114.00 | -15.31 | | | peak |
| 4* | 2402.000 | 92.56 | -2.81 | 89.75 | 94.00 | -4.25 | | | AVG |

RESULT: PASS

RADIATED EMISSION TEST- (ABOVE 1GHZ)-LOW CHANNEL- VERTICAL

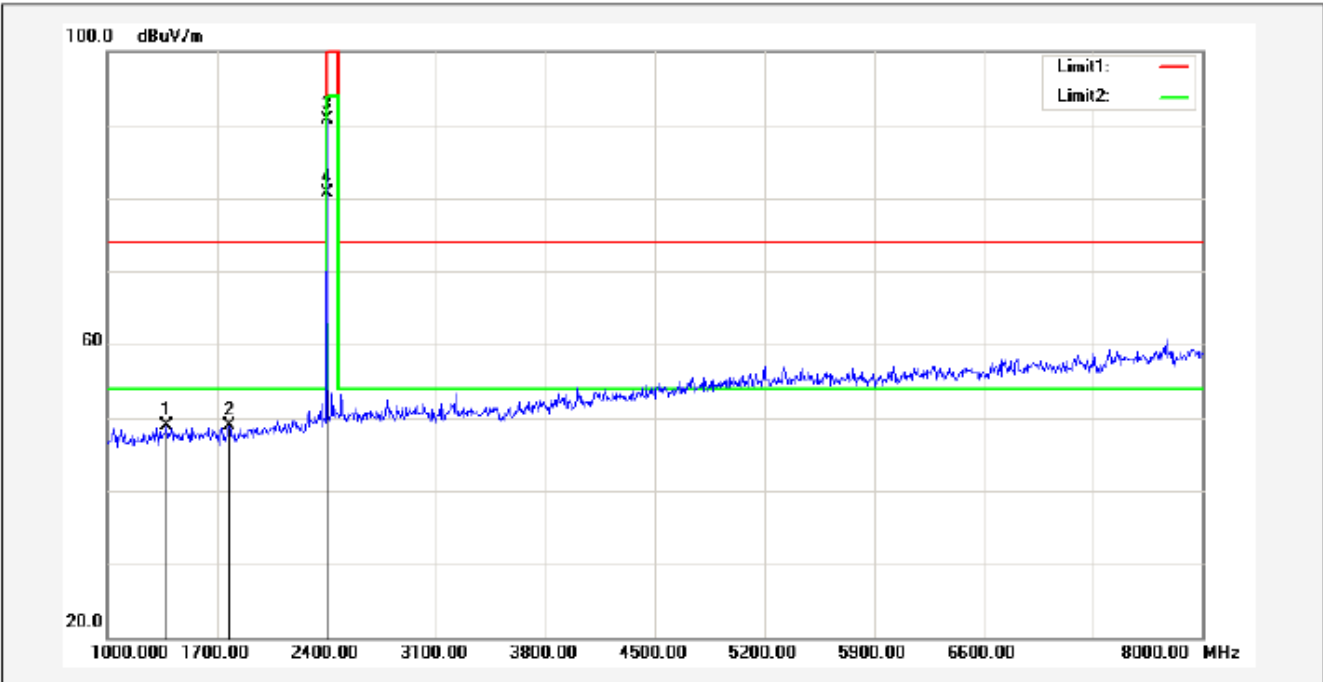

| No. | Frequency (MHz) | Reading (dBuV) | Correction factor(dB/m) | Result (dBuV/m) | Limit (dBuV/m) | Margin (dB) | Degree (deg.) | Height (cm) | Remark |
|-----|-----------------|----------------|-------------------------|-----------------|----------------|-------------|---------------|-------------|--------|
| 1 | 1378.000 | 56.01 | -7.14 | 48.87 | 74.00 | -25.13 | | | peak |
| 2 | 1777.000 | 55.31 | -6.32 | 48.99 | 74.00 | -25.01 | | | peak |
| 3X | 2402.000 | 93.60 | -2.81 | 90.79 | 114.00 | -23.21 | | | peak |
| 4* | 2402.000 | 83.50 | -2.81 | 80.69 | 94.00 | -13.31 | | | AVG |

RESULT: PASS

RADIATED EMISSION TEST- (ABOVE 1GHZ)-MIDDLE CHANNEL-HORIZONTAL

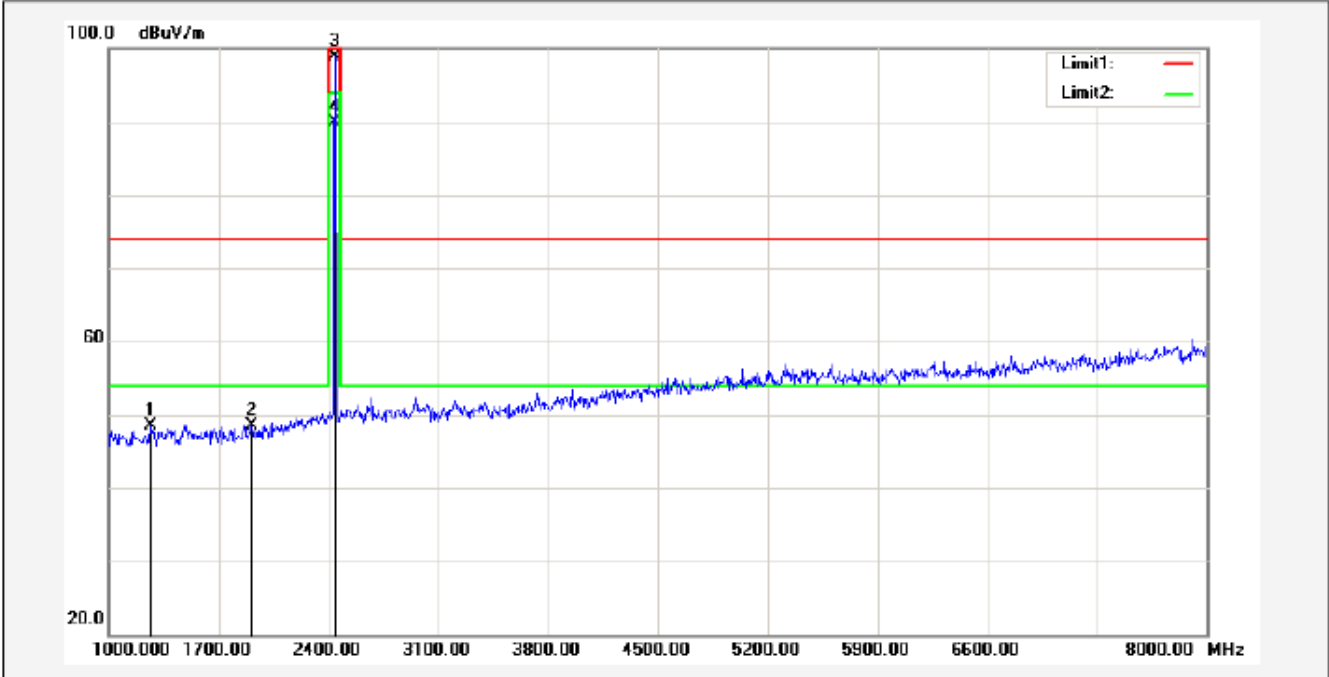

| No. | Frequency (MHz) | Reading (dBuV) | Correction factor(dB/m) | Result (dBuV/m) | Limit (dBuV/m) | Margin (dB) | Degree (deg.) | Height (cm) | Remark |
|-----|-----------------|----------------|-------------------------|-----------------|----------------|-------------|---------------|-------------|--------|
| 1 | 1266.000 | 56.14 | -7.55 | 48.59 | 74.00 | -25.41 | | | peak |
| 2 | 1910.000 | 54.06 | -5.57 | 48.49 | 74.00 | -25.51 | | | peak |
| 3 | 2441.000 | 101.57 | -2.58 | 98.99 | 114.00 | -15.01 | | | peak |
| 4* | 2441.000 | 92.45 | -2.58 | 89.87 | 94.00 | -4.13 | | | AVG |

RESULT: PASS

RADIATED EMISSION TEST- (ABOVE 1GHZ)-MIDDLE CHANNEL- VERTICAL

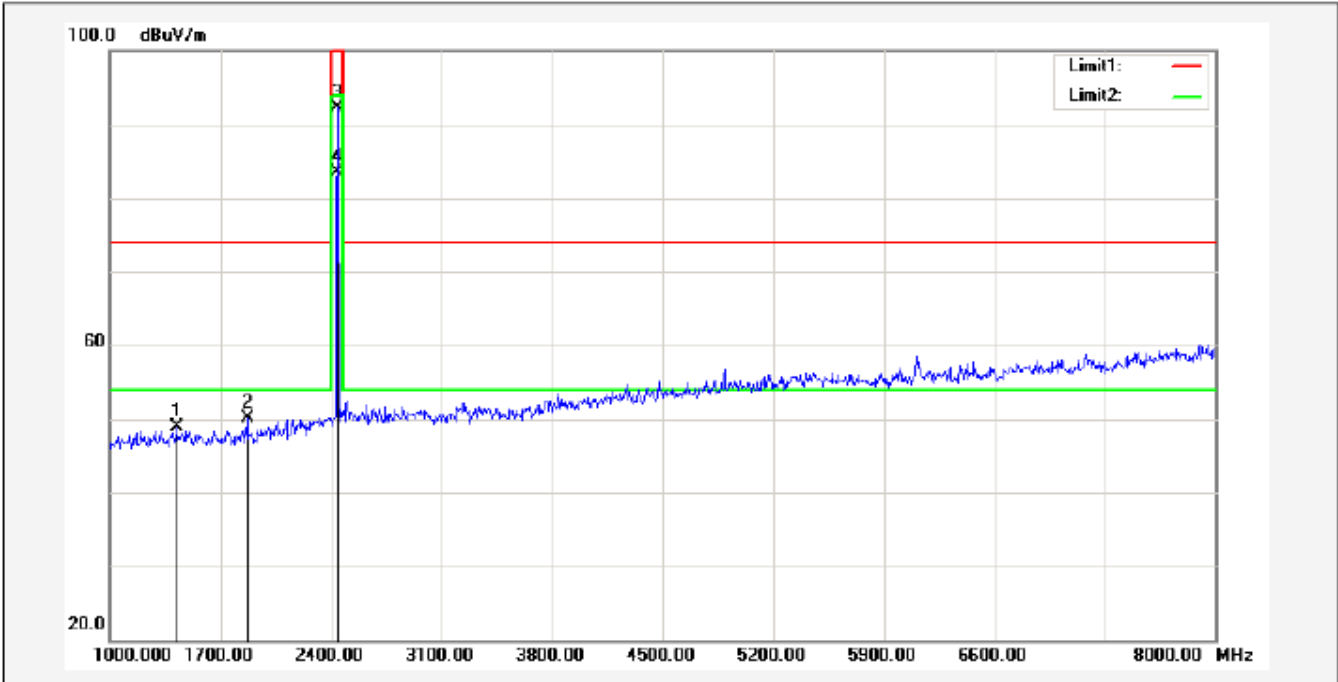

| No. | Frequency (MHz) | Reading (dBuV) | Correction factor(dB/m) | Result (dBuV/m) | Limit (dBuV/m) | Margin (dB) | Degree (deg.) | Height (cm) | Remark |
|-----|-----------------|----------------|-------------------------|-----------------|----------------|-------------|---------------|-------------|--------|
| 1 | 1420.000 | 55.97 | -7.02 | 48.95 | 74.00 | -25.05 | | | peak |
| 2 | 1868.000 | 55.97 | -5.84 | 50.13 | 74.00 | -23.87 | | | peak |
| 3 | 2441.000 | 94.89 | -2.58 | 92.31 | 114.00 | -21.69 | | | peak |
| 4* | 2441.000 | 86.16 | -2.58 | 83.58 | 94.00 | -10.42 | | | AVG |

RESULT: PASS

RADIATED EMISSION TEST- (ABOVE 1GHZ)-HIGH CHANNEL-HORIZONTAL

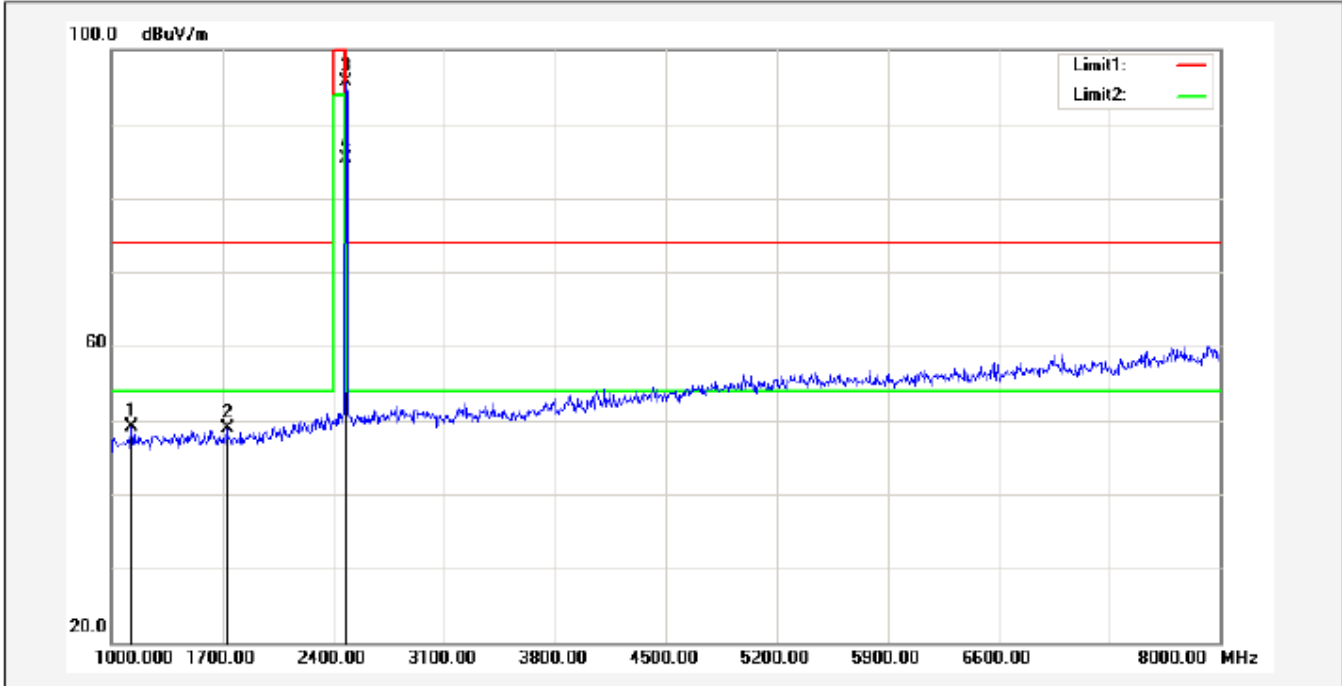

| No. | Frequency (MHz) | Reading (dBuV) | Correction factor(dB/m) | Result (dBuV/m) | Limit (dBuV/m) | Margin (dB) | Degree (deg.) | Height (cm) | Remark |
|-----|-----------------|----------------|-------------------------|-----------------|----------------|-------------|---------------|-------------|--------|
| 1 | 1126.000 | 57.20 | -8.07 | 49.13 | 74.00 | -24.87 | | | peak |
| 2 | 1728.000 | 55.25 | -6.42 | 48.83 | 74.00 | -25.17 | | | peak |
| 3 | 2480.000 | 98.10 | -2.39 | 95.71 | 114.00 | -18.29 | | | peak |
| 4* | 2480.000 | 87.69 | -2.39 | 85.30 | 94.00 | -8.70 | | | AVG |

RESULT: PASS

RADIATED EMISSION TEST- (ABOVE 1GHZ)-HIGH CHANNEL- VERTICAL

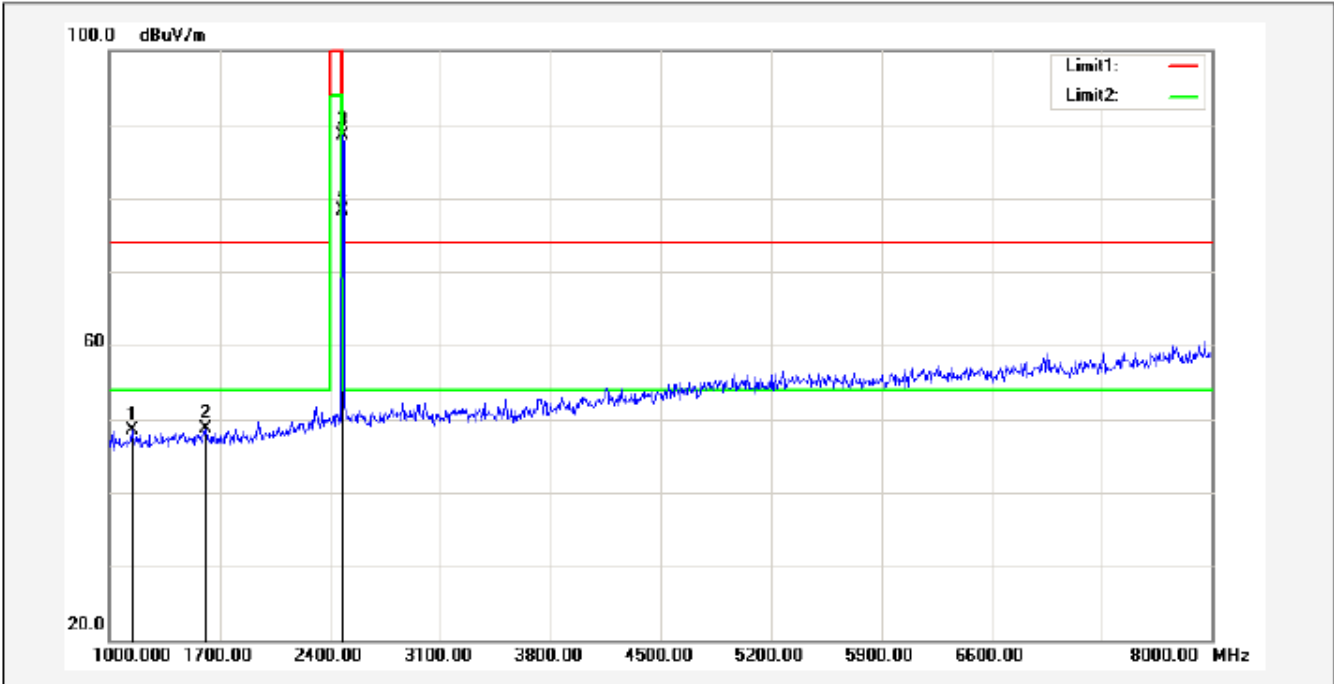

| No. | Frequency (MHz) | Reading (dBuV) | Correction factor(dB/m) | Result (dBuV/m) | Limit (dBuV/m) | Margin (dB) | Degree (deg.) | Height (cm) | Remark |
|-----|-----------------|----------------|-------------------------|-----------------|----------------|-------------|---------------|-------------|--------|
| 1 | 1140.000 | 56.58 | -8.02 | 48.56 | 74.00 | -25.44 | | | peak |
| 2 | 1609.000 | 55.46 | -6.68 | 48.78 | 74.00 | -25.22 | | | peak |
| 3 | 2480.000 | 90.96 | -2.39 | 88.57 | 114.00 | -25.43 | | | peak |
| 4* | 2480.000 | 80.60 | -2.39 | 78.21 | 94.00 | -15.79 | | | AVG |

RESULT: PASS

Note: 8GHz at least have 20dB margin. No recording in the test report.
 Factor=Antenna Factor + Cable loss - Amplifier gain, Margin=Measurement-Limit.
 The "Factor" value can be calculated automatically by software of measurement system.

Field strength of the fundamental signal

Peak value

| Frequency | Reading Level | Factor | Measurement | Limit | Over | Antenna |
|-----------|---------------|--------|-------------|----------|--------|--------------|
| (MHz) | (dBuv) | (dB/m) | (dBuv/m) | (dBuv/m) | (dB) | Polarization |
| 2402 | 101.50 | -2.81 | 98.69 | 114 | -15.31 | Horizontal |
| 2402 | 93.60 | -2.81 | 90.79 | 114 | -23.21 | Vertical |
| 2441 | 101.57 | -2.58 | 98.99 | 114 | -15.01 | Horizontal |
| 2441 | 94.89 | -2.58 | 92.31 | 114 | -21.69 | Vertical |
| 2480 | 98.10 | -2.39 | 95.71 | 114 | -18.29 | Horizontal |
| 2480 | 90.60 | -2.39 | 88.57 | 114 | -25.43 | Vertical |

Average value

| Frequency | Reading Level | Factor | Measurement | Limit | Over | Antenna |
|-----------|---------------|--------|-------------|----------|--------|--------------|
| (MHz) | (dBuv) | (dB/m) | (dBuv/m) | (dBuv/m) | (dB) | Polarization |
| 2402 | 92.56 | -2.81 | 89.75 | 94 | -4.25 | Horizontal |
| 2402 | 83.50 | -2.81 | 80.69 | 94 | -13.31 | Vertical |
| 2441 | 92.45 | -2.58 | 89.87 | 94 | -4.13 | Horizontal |
| 2441 | 86.16 | -2.58 | 83.58 | 94 | -10.42 | Vertical |
| 2480 | 87.69 | -2.39 | 85.30 | 94 | -8.70 | Horizontal |
| 2480 | 80.60 | -2.39 | 78.21 | 94 | -15.79 | Vertical |

FOR BLE

RADIATED EMISSION TEST- (ABOVE 1GHZ)-LOW CHANNEL-HORIZONTAL

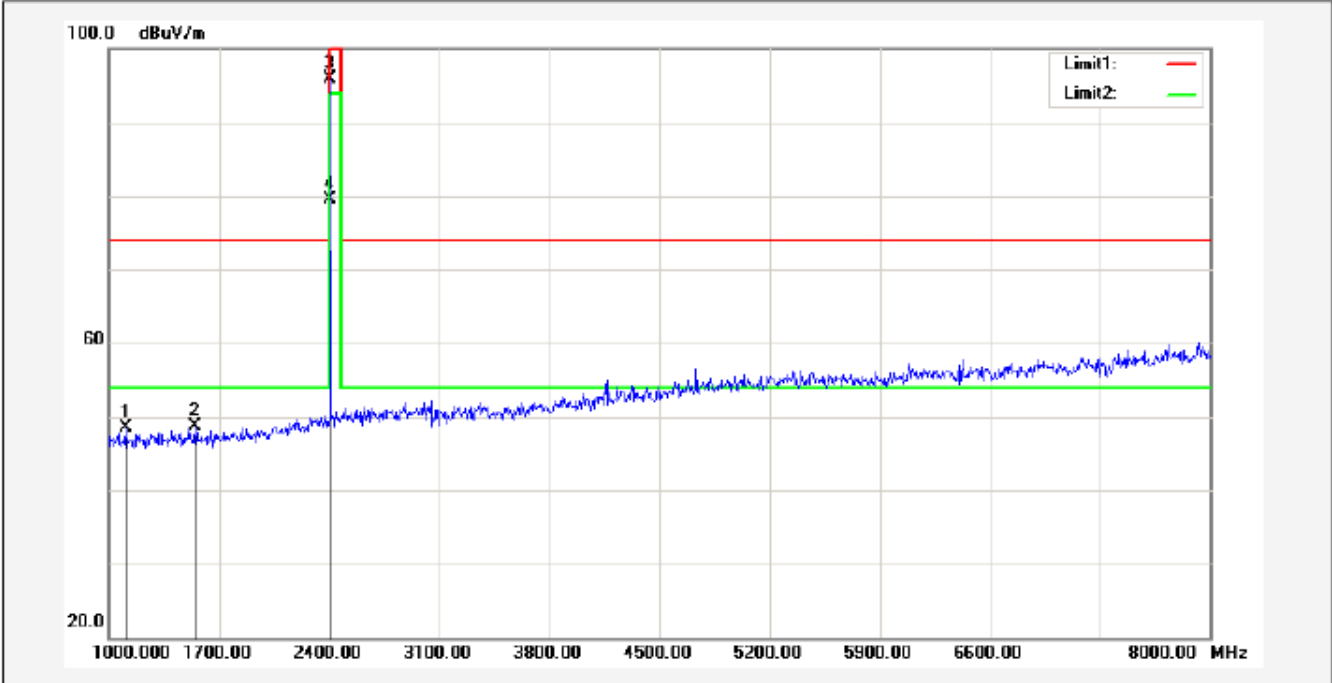

| No. | Frequency (MHz) | Reading (dBuV) | Correction factor(dB/m) | Result (dBuV/m) | Limit (dBuV/m) | Margin (dB) | Degree (deg.) | Height (cm) | Remark |
|-----|-----------------|----------------|-------------------------|-----------------|----------------|-------------|---------------|-------------|--------|
| 1 | 1105.000 | 56.71 | -8.15 | 48.56 | 74.00 | -25.44 | | | peak |
| 2 | 1546.000 | 55.58 | -6.80 | 48.78 | 74.00 | -25.22 | | | peak |
| 3 | 2402.000 | 98.76 | -2.77 | 95.99 | 114.00 | -18.01 | | | peak |
| 4* | 2402.000 | 82.35 | -2.77 | 79.58 | 94.00 | -14.42 | | | AVG |

RESULT: PASS

RADIATED EMISSION TEST- (ABOVE 1GHZ)-LOW CHANNEL- VERTICAL

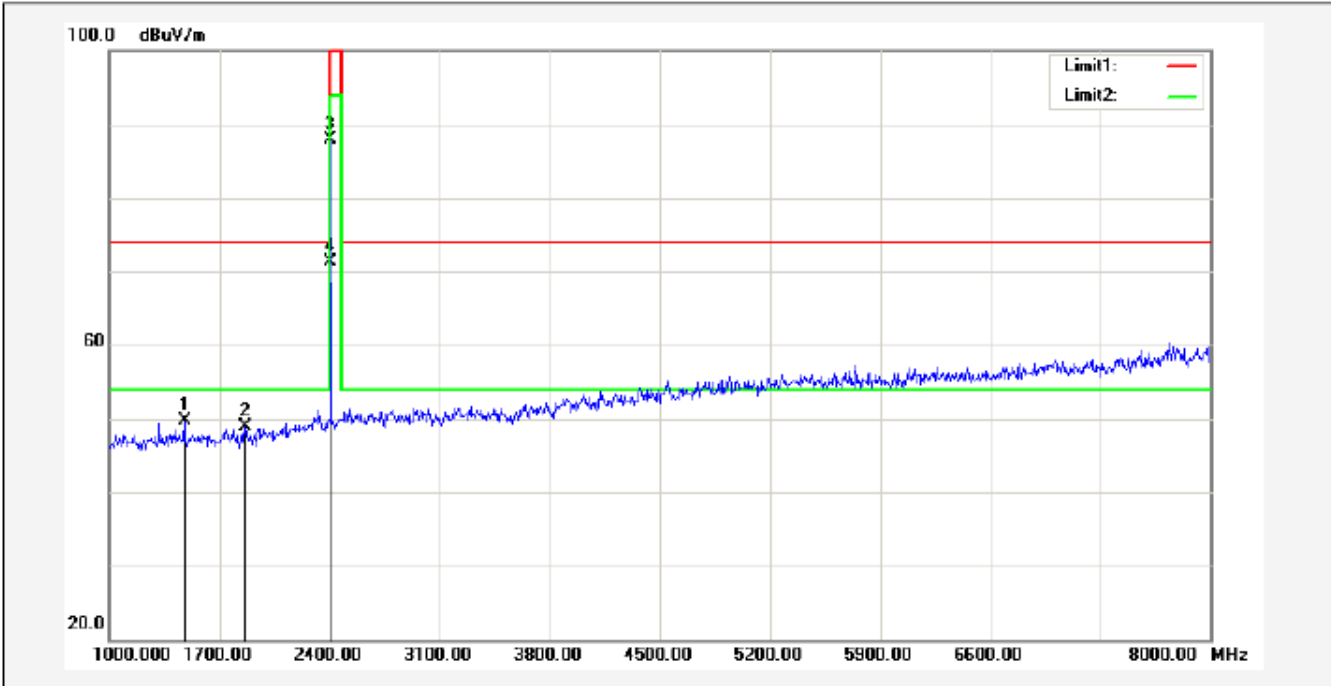

| No. | Frequency (MHz) | Reading (dBuV) | Correction factor(dB/m) | Result (dBuV/m) | Limit (dBuV/m) | Margin (dB) | Degree (deg.) | Height (cm) | Remark |
|-----|-----------------|----------------|-------------------------|-----------------|----------------|-------------|---------------|-------------|--------|
| 1 | 1476.000 | 56.60 | -6.92 | 49.68 | 74.00 | -24.32 | | | peak |
| 2 | 1861.000 | 54.76 | -5.88 | 48.88 | 74.00 | -25.12 | | | peak |
| 3 | 2402.000 | 90.69 | -2.77 | 87.92 | 114.00 | -26.08 | | | peak |
| 4* | 2402.000 | 74.03 | -2.77 | 71.26 | 94.00 | -22.74 | | | AVG |

RESULT: PASS

RADIATED EMISSION TEST- (ABOVE 1GHZ)-MIDDLE CHANNEL-HORIZONTAL

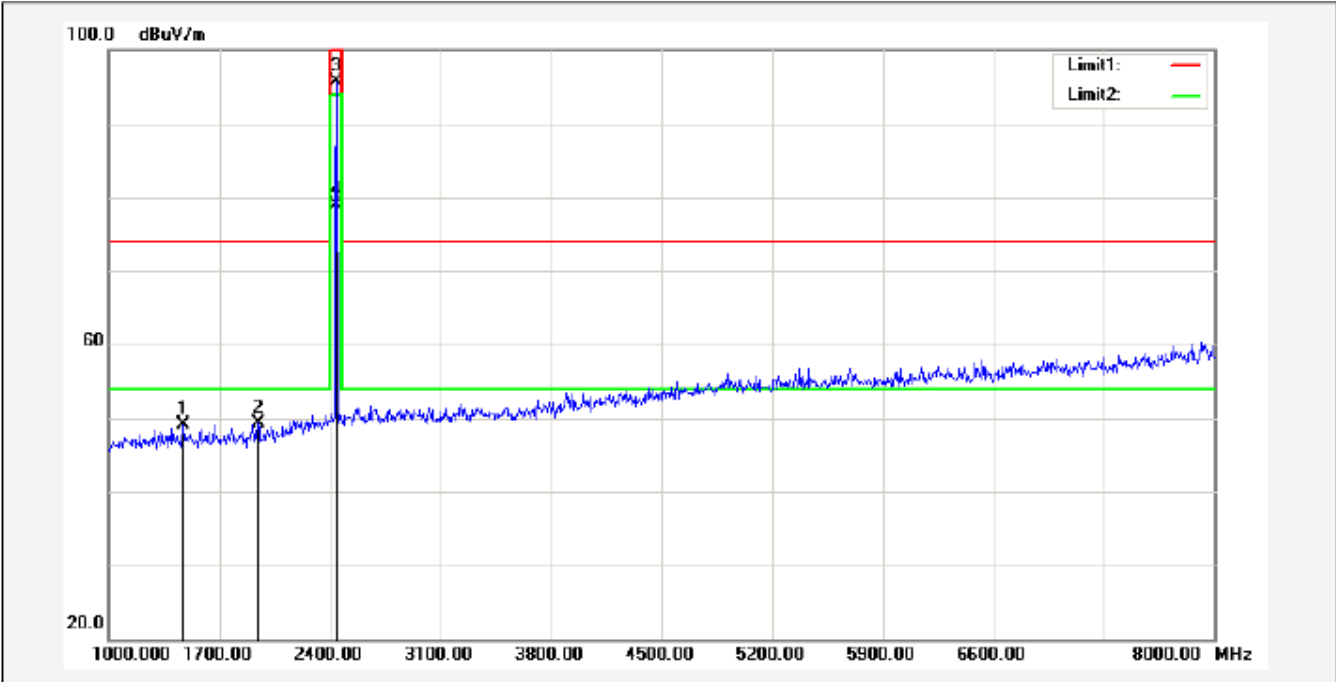

| No. | Frequency (MHz) | Reading (dBuV) | Correction factor(dB/m) | Result (dBuV/m) | Limit (dBuV/m) | Margin (dB) | Degree (deg.) | Height (cm) | Remark |
|-----|-----------------|----------------|-------------------------|-----------------|----------------|-------------|---------------|-------------|--------|
| 1 | 1469.000 | 56.06 | -6.94 | 49.12 | 74.00 | -24.88 | | | peak |
| 2 | 1945.000 | 54.72 | -5.35 | 49.37 | 74.00 | -24.63 | | | peak |
| 3 | 2440.000 | 98.34 | -2.58 | 95.76 | 114.00 | -18.24 | | | peak |
| 4* | 2440.000 | 81.40 | -2.58 | 78.82 | 94.00 | -15.18 | | | AVG |

RESULT: PASS

RADIATED EMISSION TEST- (ABOVE 1GHZ)-MIDDLE CHANNEL- VERTICAL

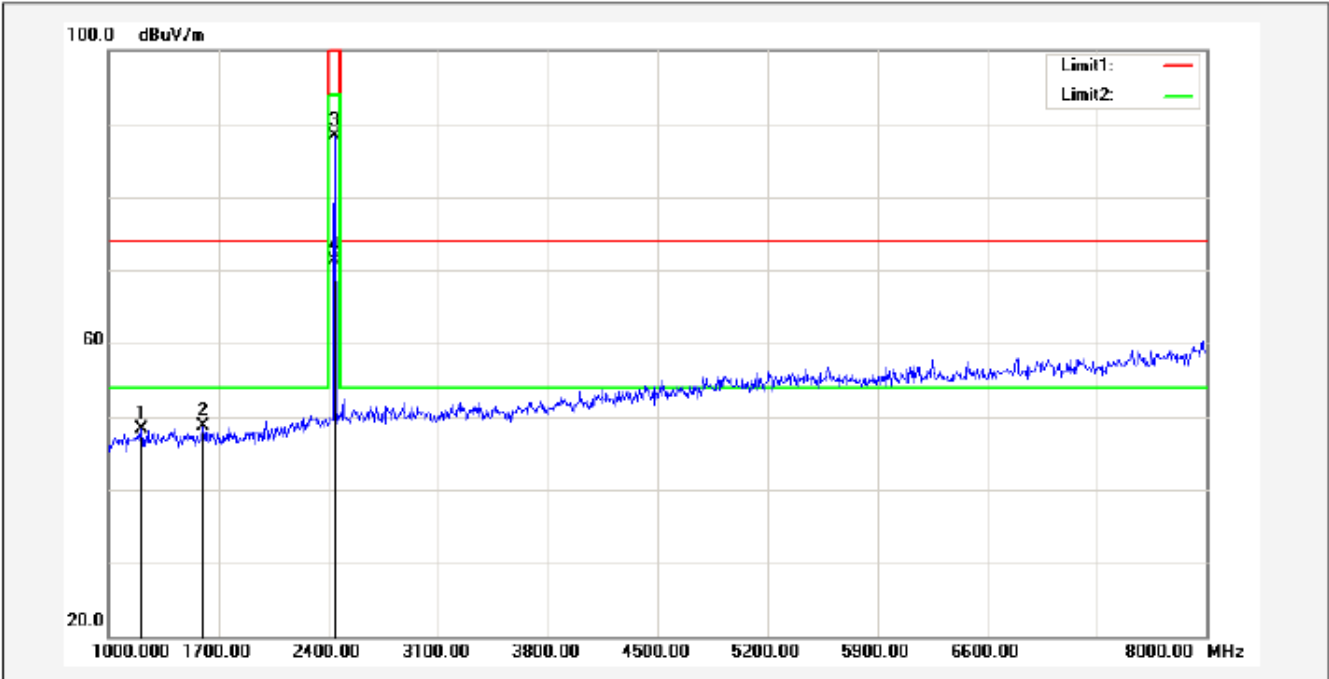

| No. | Frequency (MHz) | Reading (dBuV) | Correction factor(dB/m) | Result (dBuV/m) | Limit (dBuV/m) | Margin (dB) | Degree (deg.) | Height (cm) | Remark |
|-----|-----------------|----------------|-------------------------|-----------------|----------------|-------------|---------------|-------------|--------|
| 1 | 1210.000 | 56.13 | -7.75 | 48.38 | 74.00 | -25.62 | | | peak |
| 2 | 1602.000 | 55.31 | -6.70 | 48.61 | 74.00 | -25.39 | | | peak |
| 3 | 2440.000 | 90.84 | -2.58 | 88.26 | 114.00 | -25.74 | | | peak |
| 4* | 2440.000 | 73.96 | -2.58 | 71.38 | 94.00 | -22.62 | | | AVG |

RESULT: PASS

RADIATED EMISSION TEST- (ABOVE 1GHZ)-HIGH CHANNEL-HORIZONTAL

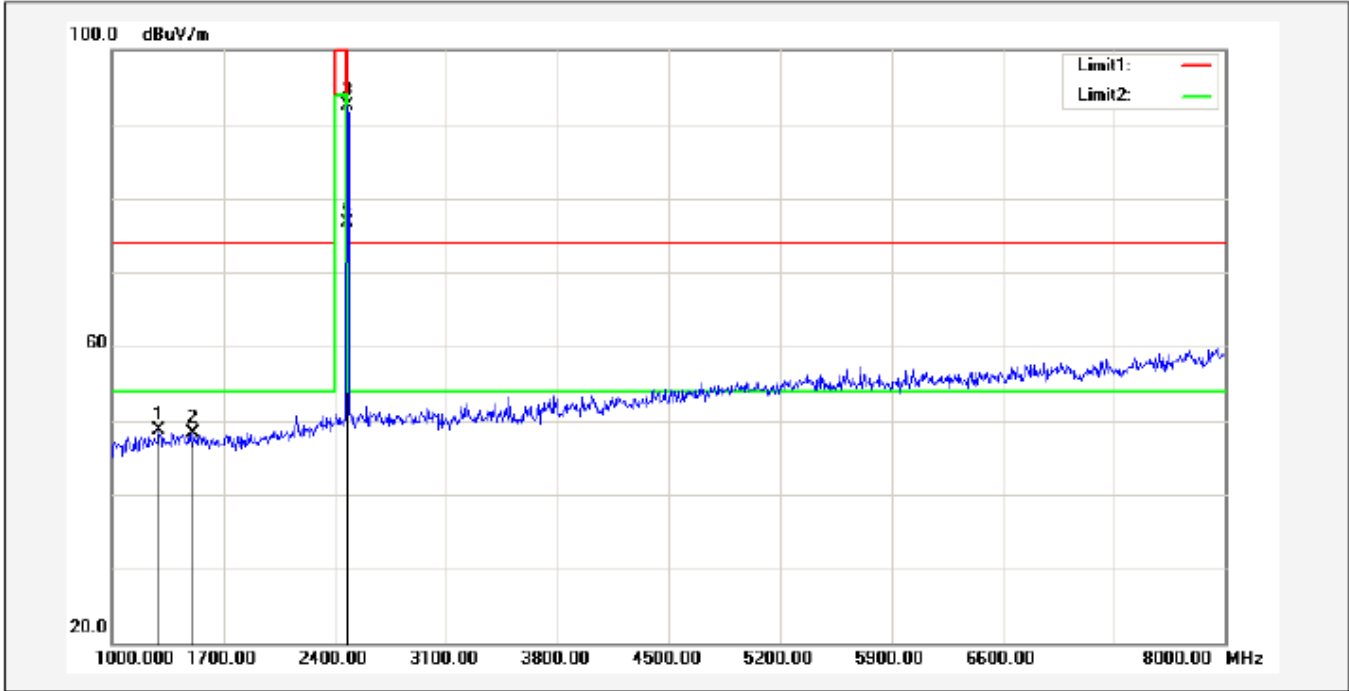

| No. | Frequency (MHz) | Reading (dBuV) | Correction factor(dB/m) | Result (dBuV/m) | Limit (dBuV/m) | Margin (dB) | Degree (deg.) | Height (cm) | Remark |
|-----|-----------------|----------------|-------------------------|-----------------|----------------|-------------|---------------|-------------|--------|
| 1 | 1294.000 | 56.11 | -7.45 | 48.66 | 74.00 | -25.34 | | | peak |
| 2 | 1511.000 | 55.16 | -6.86 | 48.30 | 74.00 | -25.70 | | | peak |
| 3 | 2480.000 | 94.94 | -2.39 | 92.55 | 114.00 | -21.45 | | | peak |
| 4* | 2480.000 | 79.08 | -2.39 | 76.69 | 94.00 | -17.31 | | | AVG |

RESULT: PASS

RADIATED EMISSION TEST- (ABOVE 1GHZ)-HIGH CHANNEL- VERTICAL

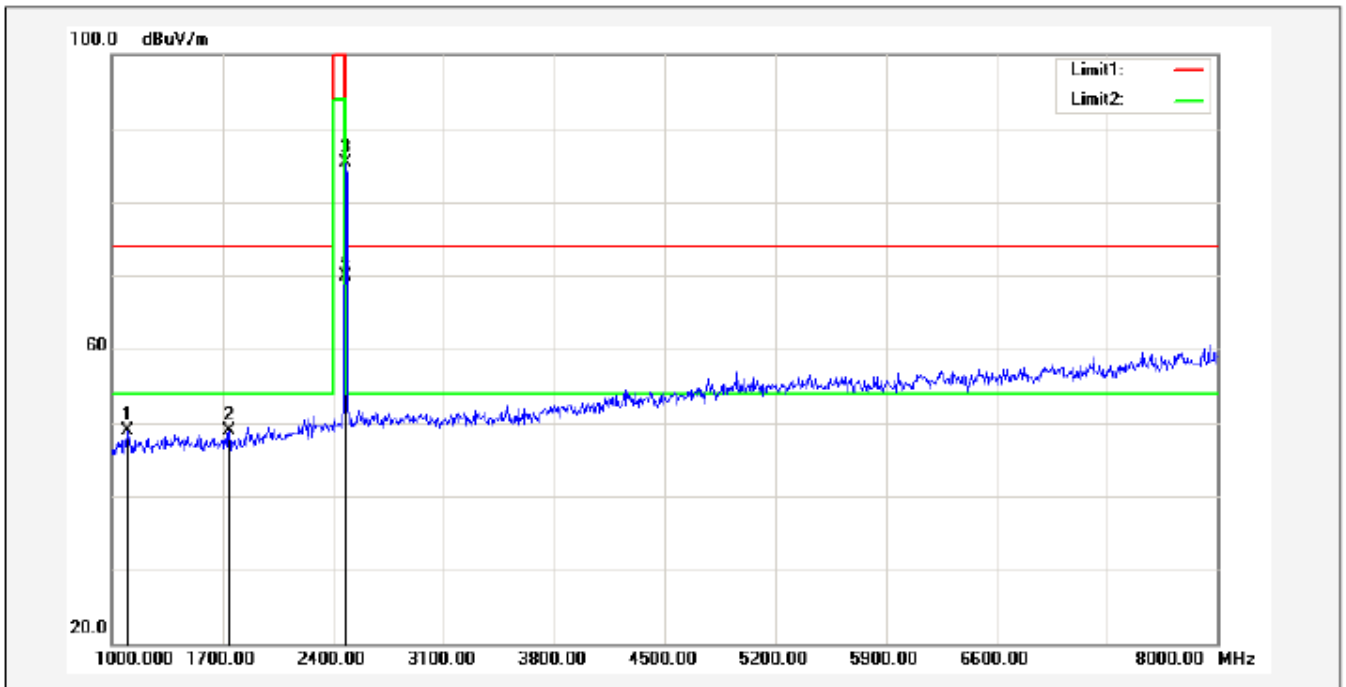

| No. | Frequency (MHz) | Reading (dBuV) | Correction factor(dB/m) | Result (dBuV/m) | Limit (dBuV/m) | Margin (dB) | Degree (deg.) | Height (cm) | Remark |
|-----|-----------------|----------------|-------------------------|-----------------|----------------|-------------|---------------|-------------|--------|
| 1 | 1098.000 | 57.06 | -8.18 | 48.88 | 74.00 | -25.12 | | | peak |
| 2 | 1742.000 | 55.31 | -6.39 | 48.92 | 74.00 | -25.08 | | | peak |
| 3 | 2480.000 | 87.70 | -2.39 | 85.31 | 114.00 | -28.69 | | | peak |
| 4* | 2480.000 | 72.21 | -2.39 | 69.82 | 94.00 | -24.18 | | | AVG |

RESULT: PASS

Note: 8GHz at least have 20dB margin. No recording in the test report.

Factor=Antenna Factor + Cable loss - Amplifier gain, Margin=Measurement-Limit.

The "Factor" value can be calculated automatically by software of measurement system.

Field strength of the fundamental signal

Peak value

| Frequency | Reading Level | Factor | Measurement | Limit | Over | Antenna |
|-----------|---------------|--------|-------------|----------|--------|--------------|
| (MHz) | (dBuv) | (dB/m) | (dBuv/m) | (dBuv/m) | (dB) | Polarization |
| 2402 | 98.76 | -2.77 | 95.99 | 114 | -18.01 | Horizontal |
| 2402 | 90.69 | -2.77 | 87.92 | 114 | -26.08 | Vertical |
| 2440 | 98.34 | -2.58 | 95.76 | 114 | -18.24 | Horizontal |
| 2440 | 90.84 | -2.58 | 88.26 | 114 | -25.74 | Vertical |
| 2480 | 94.94 | -2.39 | 92.55 | 114 | -21.45 | Horizontal |
| 2480 | 87.70 | -2.39 | 85.31 | 114 | -28.69 | Vertical |

Average value

| Frequency | Reading Level | Factor | Measurement | Limit | Over | Antenna |
|-----------|---------------|--------|-------------|----------|--------|--------------|
| (MHz) | (dBuv) | (dB/m) | (dBuv/m) | (dBuv/m) | (dB) | Polarization |
| 2402 | 82.35 | -2.77 | 79.58 | 94 | -14.42 | Horizontal |
| 2402 | 74.03 | -2.77 | 71.26 | 94 | -22.74 | Vertical |
| 2440 | 81.40 | -2.58 | 78.82 | 94 | -15.18 | Horizontal |
| 2440 | 73.96 | -2.58 | 71.38 | 94 | -22.62 | Vertical |
| 2480 | 79.08 | -2.39 | 76.69 | 94 | -17.31 | Horizontal |
| 2480 | 72.21 | -2.39 | 69.82 | 94 | -24.18 | Vertical |

9. BAND EDGE EMISSION

9.1. MEASUREMENT PROCEDURE

1The EUT operates at hopping-off test mode. The lowest or highest channels are tested to verify the largest transmission and spurious emissions power at the continuous transmission mode.

2Max hold the trace of the setp 1,and the EUT operates at hopping-on test mode to verify the largest spurious emissions power.

3Set the spectrum analyzer in the following setting in order to capture the lower and upper band-edges of the emission: (a) PEAK: RBW=VBW=1.5MHz / Sweep=AUTO

(b) AVERAGE: RBW=1.5MHz ; VBW=1/on time(1KHz) / Sweep=AUTO

9.2 TEST SETUP

RADIATED EMISSION TEST SETUP

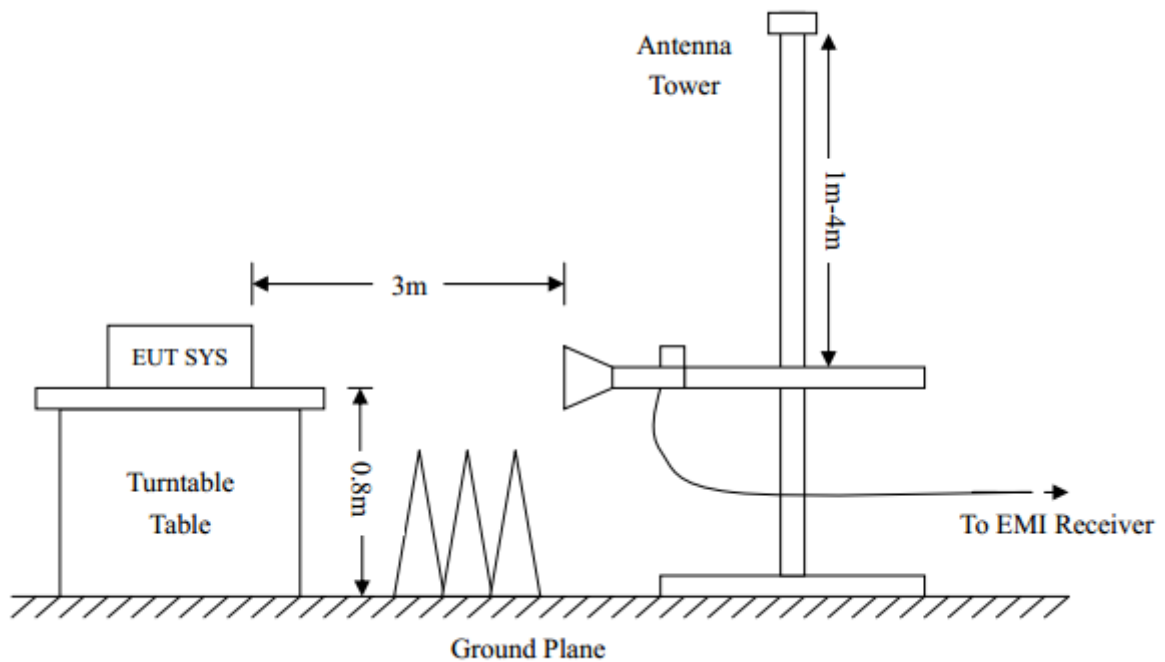

CONDUCTED TEST SETUP

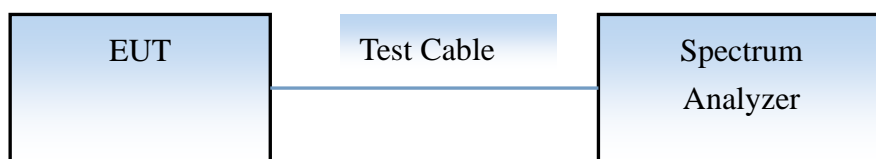

9.3 RADIATED TEST RESULT
(Worst modulation: GFSK)
FOR BR/EDR BLEUOTOOTH

TEST PLOT OF BAND EDGE FOR LOW CHANNEL-Horizontal

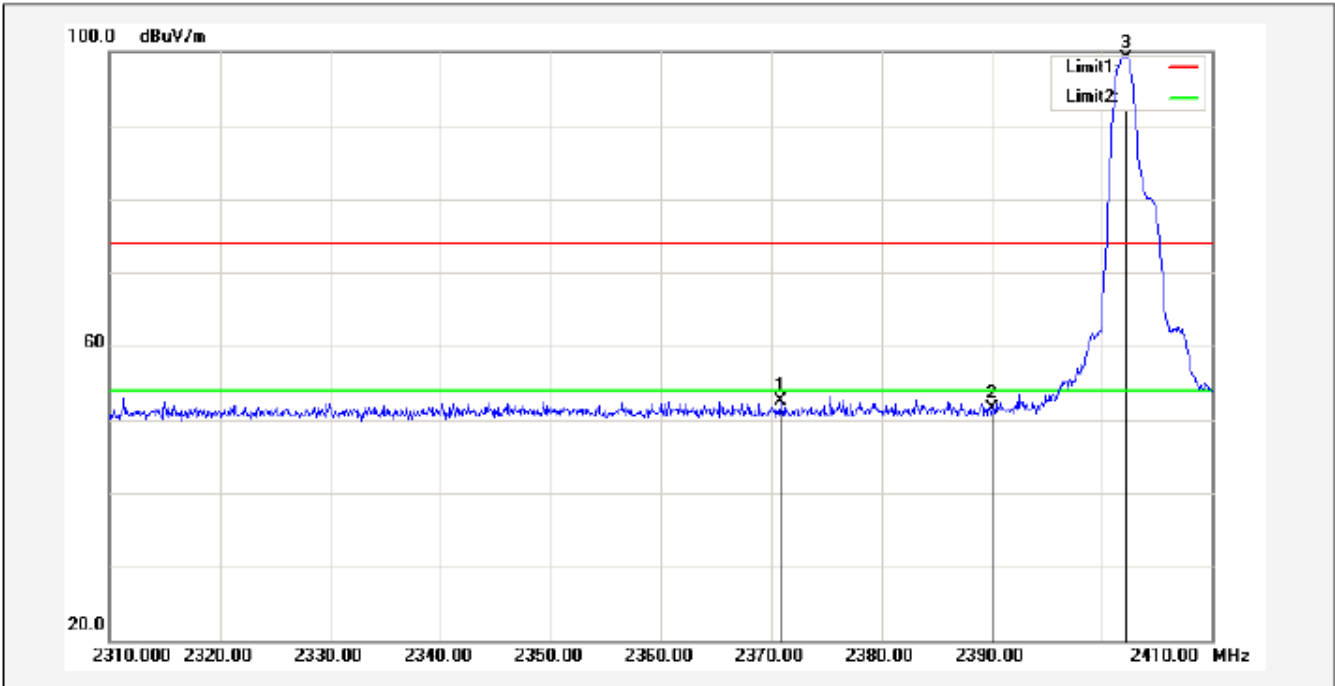

| No. | Frequency (MHz) | Reading (dBuV) | Correction factor(dB/m) | Result (dBuV/m) | Limit (dBuV/m) | Margin (dB) | Degree (deg.) | Height (cm) | Remark |
|-----|-----------------|----------------|-------------------------|-----------------|----------------|-------------|---------------|-------------|--------|
| 1 | 2370.800 | 55.43 | -2.97 | 52.46 | 74.00 | -21.54 | | | peak |
| 2 | 2390.000 | 54.43 | -2.86 | 51.57 | 74.00 | -22.43 | | | peak |
| 3* | 2402.200 | 102.00 | -2.80 | 99.20 | 74.00 | 25.20 | | | peak |

TEST PLOT OF BAND EDGE FOR LOW CHANNEL –Vertical

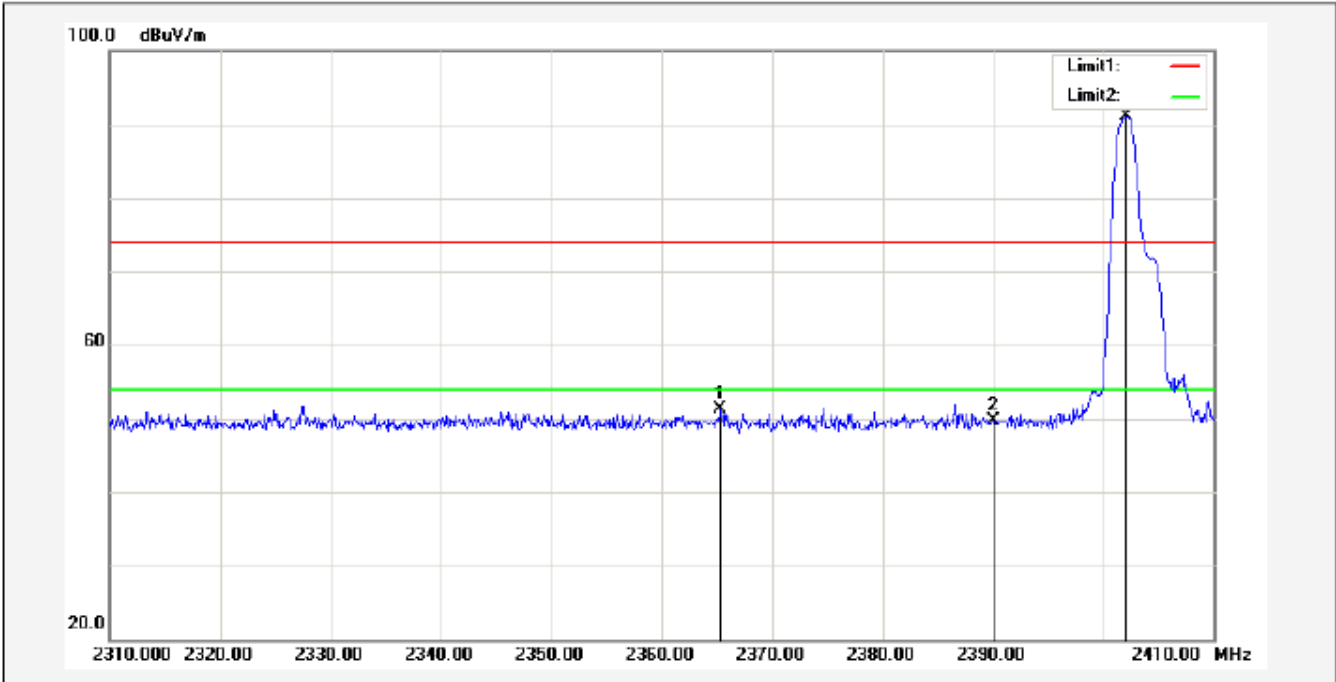

| No. | Frequency (MHz) | Reading (dBuV) | Correction factor(dB/m) | Result (dBuV/m) | Limit (dBuV/m) | Margin (dB) | Degree (deg.) | Height (cm) | Remark |
|-----|-----------------|----------------|-------------------------|-----------------|----------------|-------------|---------------|-------------|--------|
| 1 | 2365.300 | 54.33 | -3.00 | 51.33 | 74.00 | -22.67 | | | peak |
| 2 | 2390.000 | 52.49 | -2.86 | 49.63 | 74.00 | -24.37 | | | peak |
| 3* | 2402.100 | 93.81 | -2.80 | 91.01 | 74.00 | 17.01 | | | peak |

TEST PLOT OF BAND EDGE FOR HIGH CHANNEL -Horizontal

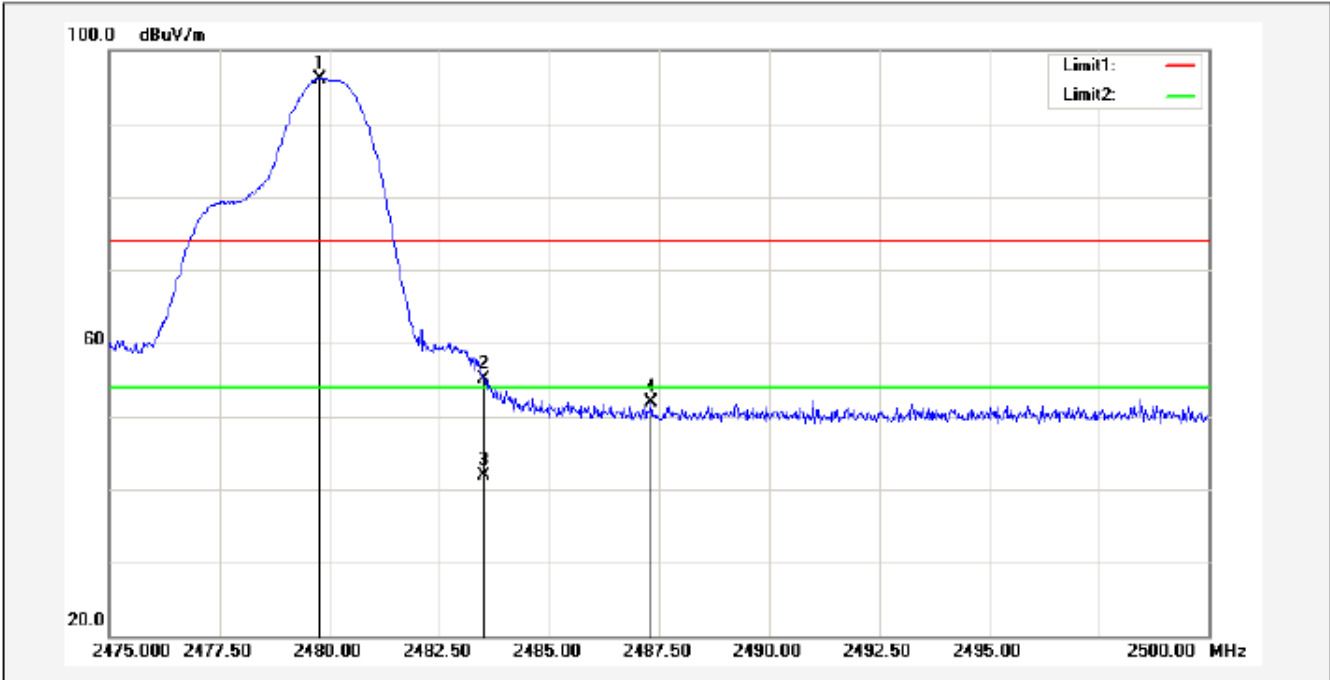

| No. | Frequency (MHz) | Reading (dBuV) | Correction factor(dB/m) | Result (dBuV/m) | Limit (dBuV/m) | Margin (dB) | Degree (deg.) | Height (cm) | Remark |
|-----|-----------------|----------------|-------------------------|-----------------|----------------|-------------|---------------|-------------|--------|
| 1* | 2479.775 | 98.53 | -2.37 | 96.16 | 74.00 | 22.16 | | | peak |
| 2 | 2483.500 | 57.41 | -2.35 | 55.06 | 74.00 | -18.94 | | | peak |
| 3 | 2483.500 | 44.22 | -2.35 | 41.87 | 54.00 | -12.13 | | | AVG |
| 4 | 2487.325 | 54.26 | -2.33 | 51.93 | 74.00 | -22.07 | | | peak |

TEST PLOT OF BAND EDGE FOR HIGH CHANNEL-Vertical

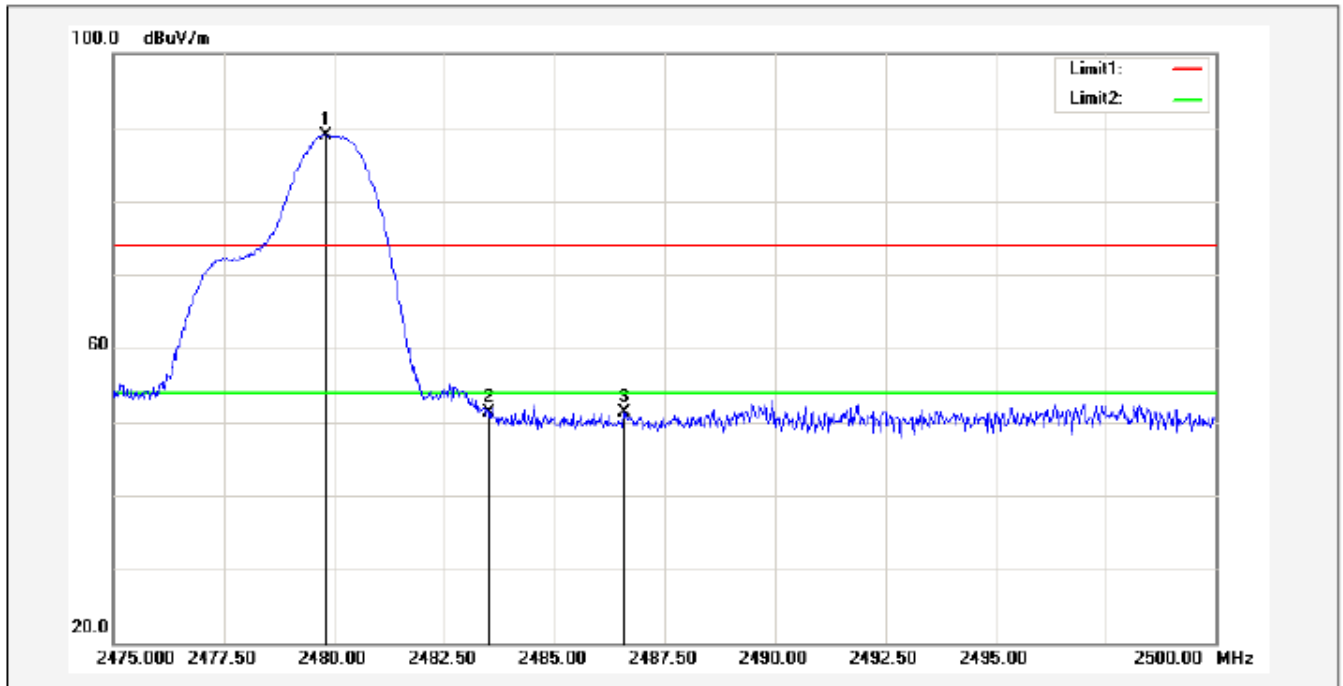

| No. | Frequency (MHz) | Reading (dBuV) | Correction factor(dB/m) | Result (dBuV/m) | Limit (dBuV/m) | Margin (dB) | Degree (deg.) | Height (cm) | Remark |
|-----|-----------------|----------------|-------------------------|-----------------|----------------|-------------|---------------|-------------|--------|
| 1* | 2479.800 | 91.27 | -2.37 | 88.90 | 74.00 | 14.90 | | | peak |
| 2 | 2483.500 | 53.75 | -2.35 | 51.40 | 74.00 | -22.60 | | | peak |
| 3 | 2486.575 | 53.57 | -2.33 | 51.24 | 74.00 | -22.76 | | | peak |

RESULT: PASS

Note: The other modes radiation emission have enough 20dB margin.

Factor=Antenna Factor + Cable loss - Amplifier gain, Over=Measure-Limit.

The "Factor" value can be calculated automatically by software of measurement system.

FOR BLE

TEST PLOT OF BAND EDGE FOR LOW CHANNEL-Horizontal

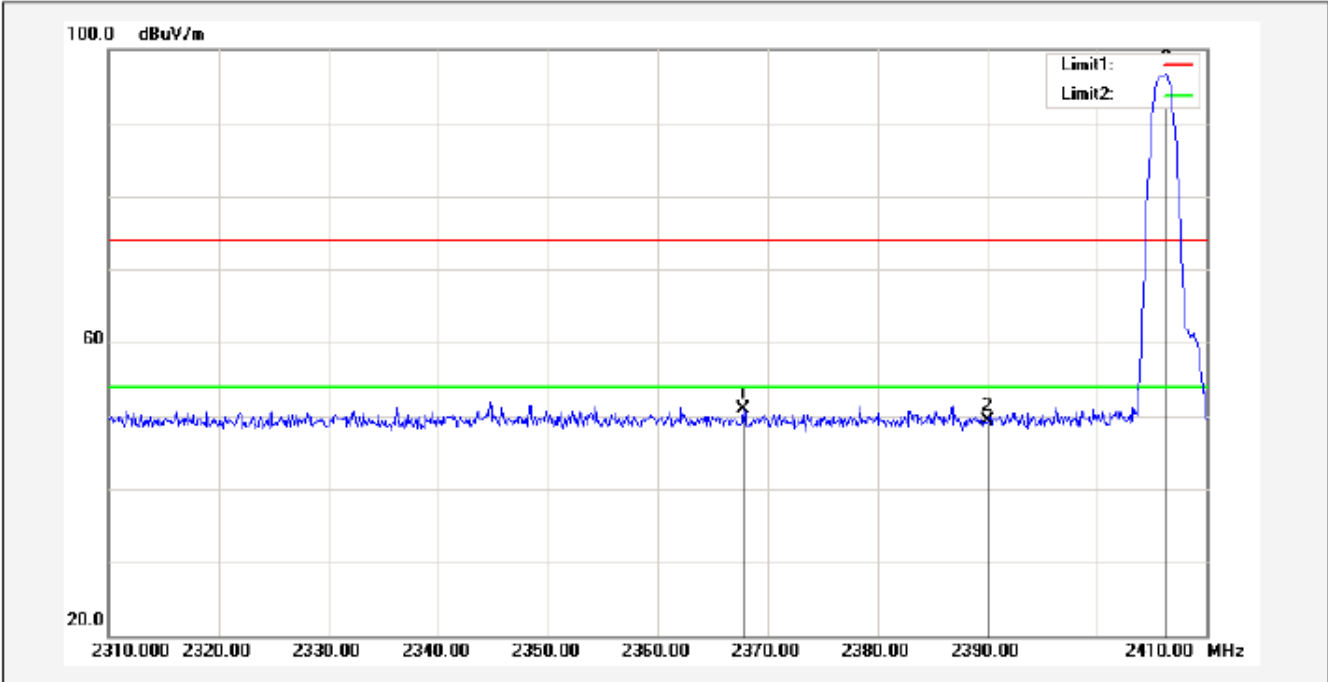

| No. | Frequency (MHz) | Reading (dBuV) | Correction factor(dB/m) | Result (dBuV/m) | Limit (dBuV/m) | Margin (dB) | Degree (deg.) | Height (cm) | Remark |
|-----|-----------------|----------------|-------------------------|-----------------|----------------|-------------|---------------|-------------|--------|
| 1 | 2367.800 | 53.89 | -2.98 | 50.91 | 74.00 | -23.09 | | | peak |
| 2 | 2390.000 | 52.23 | -2.86 | 49.37 | 74.00 | -24.63 | | | peak |
| 3* | 2406.300 | 99.41 | -2.77 | 96.64 | 74.00 | 22.64 | | | peak |

TEST PLOT OF BAND EDGE FOR LOW CHANNEL –Vertical

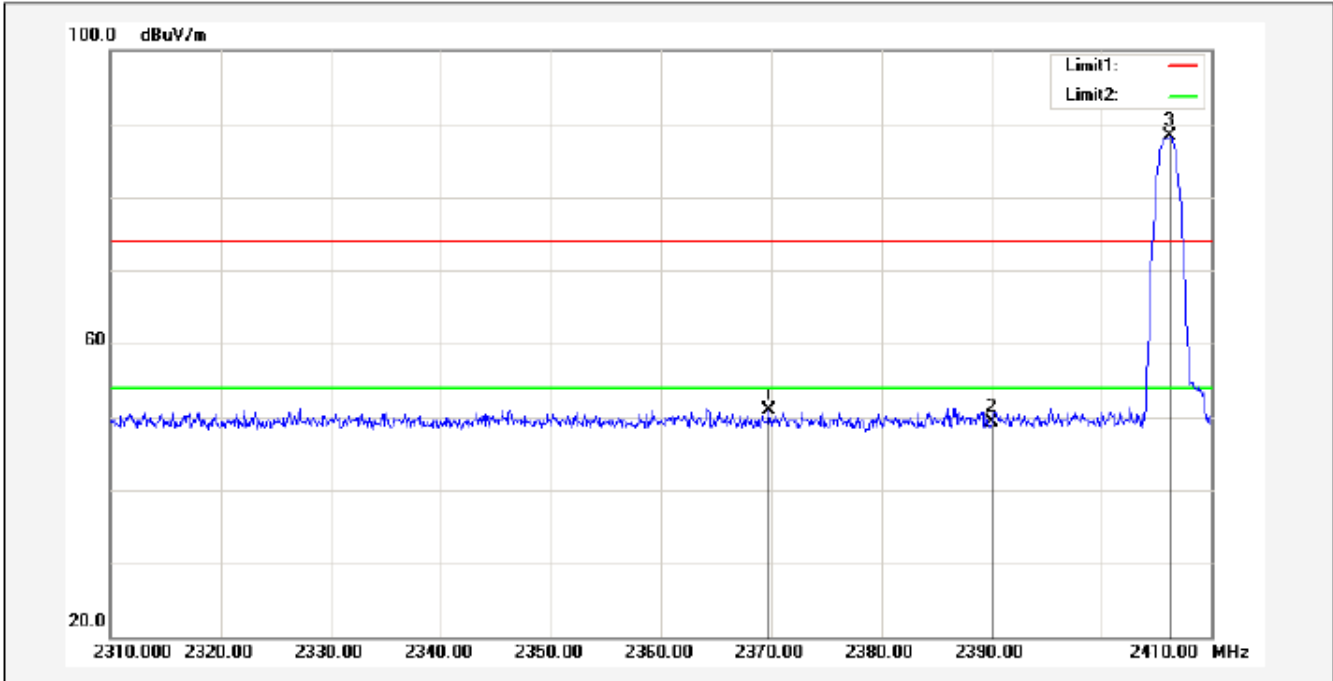

| No. | Frequency (MHz) | Reading (dBuV) | Correction factor(dB/m) | Result (dBuV/m) | Limit (dBuV/m) | Margin (dB) | Degree (deg.) | Height (cm) | Remark |
|-----|-----------------|----------------|-------------------------|-----------------|----------------|-------------|---------------|-------------|--------|
| 1 | 2369.800 | 53.94 | -2.97 | 50.97 | 74.00 | -23.03 | | | peak |
| 2 | 2390.000 | 52.13 | -2.86 | 49.27 | 74.00 | -24.73 | | | peak |
| 3* | 2406.200 | 91.07 | -2.77 | 88.30 | 74.00 | 14.30 | | | peak |

TEST PLOT OF BAND EDGE FOR HIGH CHANNEL -Horizontal

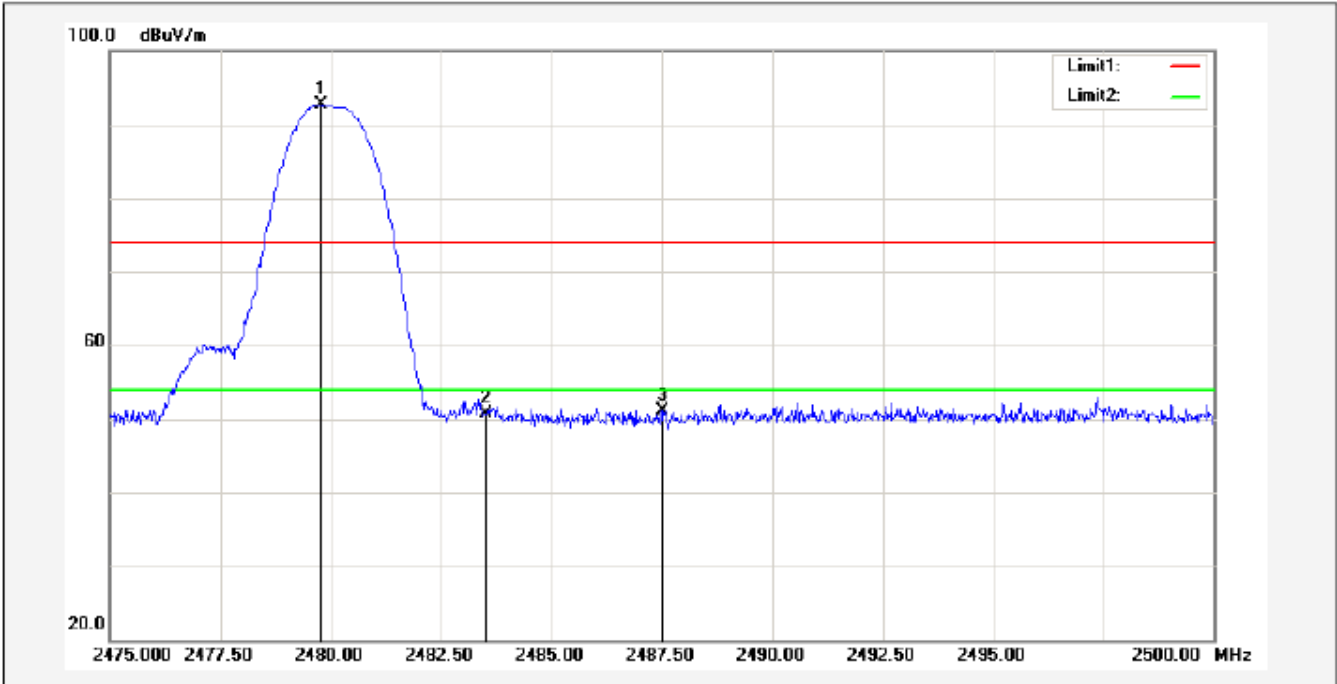

| No. | Frequency (MHz) | Reading (dBuV) | Correction factor(dB/m) | Result (dBuV/m) | Limit (dBuV/m) | Margin (dB) | Degree (deg.) | Height (cm) | Remark |
|-----|-----------------|----------------|-------------------------|-----------------|----------------|-------------|---------------|-------------|--------|
| 1* | 2479.775 | 95.08 | -2.37 | 92.71 | 74.00 | 18.71 | | | peak |
| 2 | 2483.500 | 53.06 | -2.35 | 50.71 | 74.00 | -23.29 | | | peak |
| 3 | 2487.500 | 53.53 | -2.33 | 51.20 | 74.00 | -22.80 | | | peak |

TEST PLOT OF BAND EDGE FOR HIGH CHANNEL-Vertical

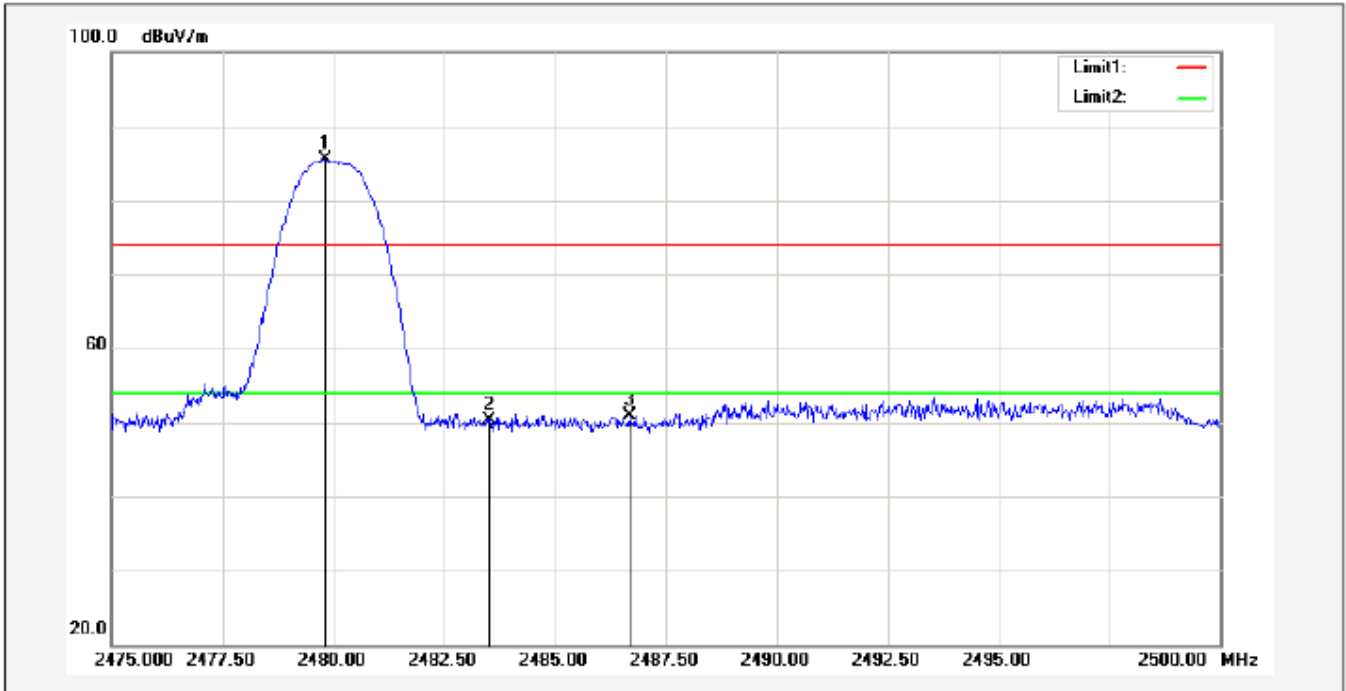

| No. | Frequency (MHz) | Reading (dBuV) | Correction factor(dB/m) | Result (dBuV/m) | Limit (dBuV/m) | Margin (dB) | Degree (deg.) | Height (cm) | Remark |
|-----|-----------------|----------------|-------------------------|-----------------|----------------|-------------|---------------|-------------|--------|
| 1* | 2479.800 | 87.81 | -2.37 | 85.44 | 74.00 | 11.44 | | | peak |
| 2 | 2483.500 | 52.64 | -2.35 | 50.29 | 74.00 | -23.71 | | | peak |
| 3 | 2486.675 | 53.17 | -2.33 | 50.84 | 74.00 | -23.16 | | | peak |

RESULT: PASS

Note: The other modes radiation emission have enough 20dB margin.

Factor=Antenna Factor + Cable loss - Amplifier gain, Over=Measure-Limit.

The "Factor" value can be calculated automatically by software of measurement system.

10. 20DB BANDWIDTH

10.1. MEASUREMENT PROCEDURE

1. Connect EUT RF output port to the Spectrum Analyzer through an RF attenuator
2. Set the EUT Work on the top, the middle and the bottom operation frequency individually.
3. Set Span = approximately 2 to 3 times the 20 dB bandwidth, centered on a hopping channel
 $RBW \geq 1\%$ of the 20 dB bandwidth, $VBW \geq RBW$; Sweep = auto; Detector function = peak
4. Set SPA Trace 1 Max hold, then View.

10.2. TEST SET-UP

(BLOCK DIAGRAM OF CONFIGURATION)

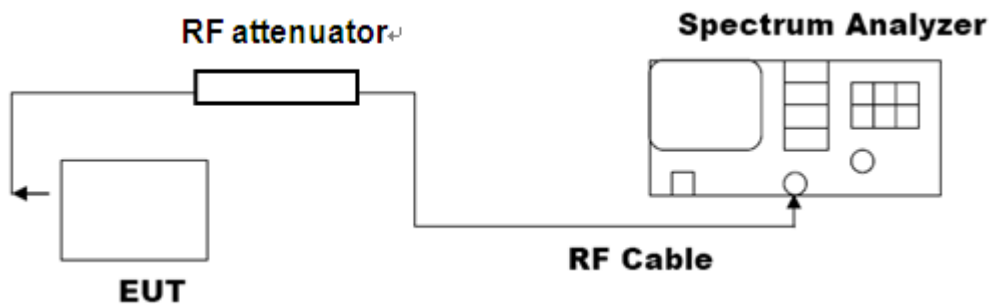

10.3. LIMITS AND MEASUREMENT RESULTS

FOR BR/EDR BLUETOOTH

| BLUETOOTH 1MBPS LIMITS AND MEASUREMENT RESULT | | | |
|---|--------------------|-------|----------|
| Applicable Limits | Measurement Result | | |
| | Test Data (MHz) | | Criteria |
| N/A | Low Channel | 0.918 | PASS |
| | Middle Channel | 0.881 | PASS |
| | High Channel | 0.873 | PASS |

TEST PLOT OF BANDWIDTH FOR LOW CHANNEL



TEST PLOT OF BANDWIDTH FOR MIDDLE CHANNEL

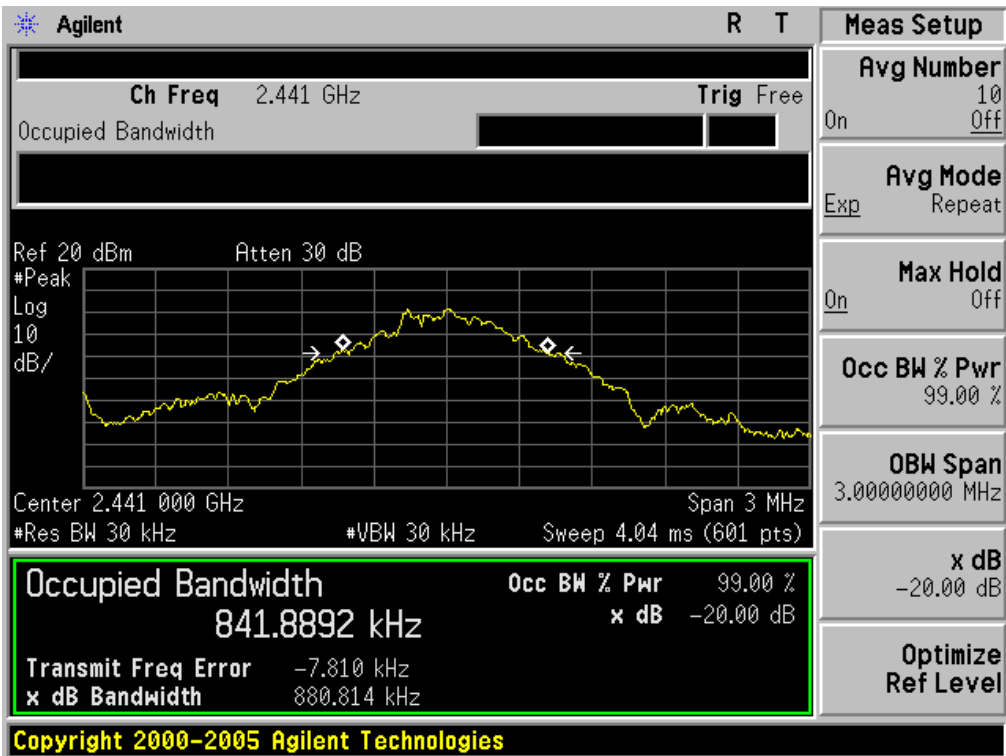

TEST PLOT OF BANDWIDTH FOR HIGH CHANNEL



| BLUETOOTH 2MBPS LIMITS AND MEASUREMENT RESULT | | | |
|---|--------------------|-------|----------|
| Applicable Limits | Measurement Result | | |
| | Test Data (MHz) | | Criteria |
| N/A | Low Channel | 1.248 | PASS |
| | Middle Channel | 1.252 | PASS |
| | High Channel | 1.308 | PASS |

TEST PLOT OF BANDWIDTH FOR LOW CHANNEL

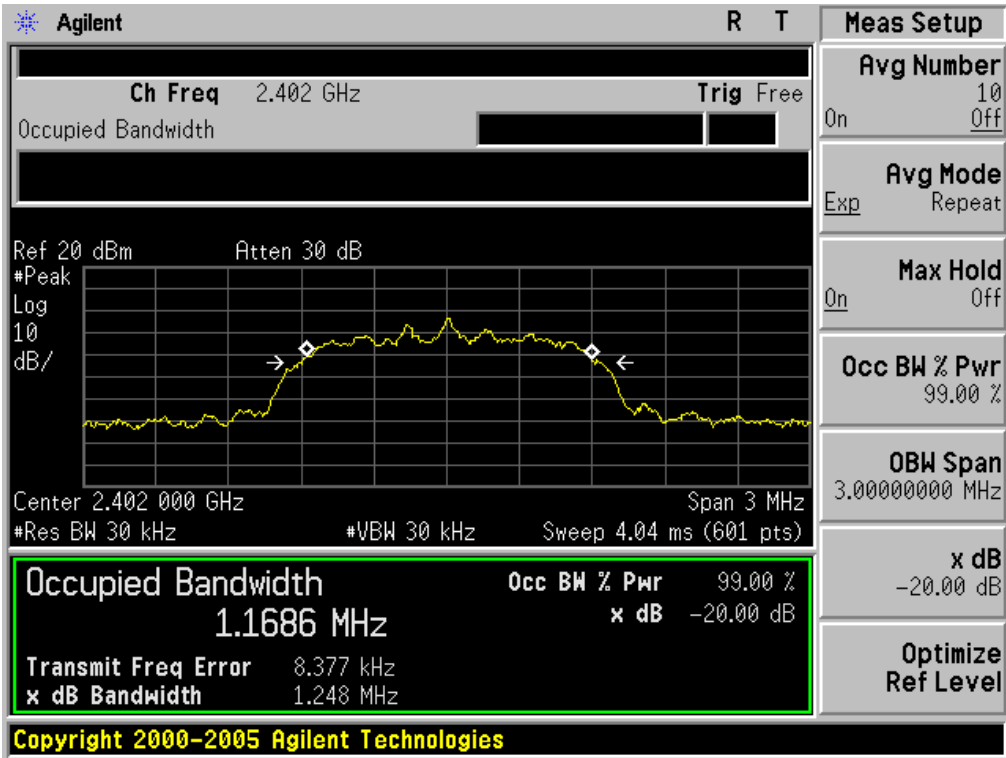

TEST PLOT OF BANDWIDTH FOR MIDDLE CHANNEL

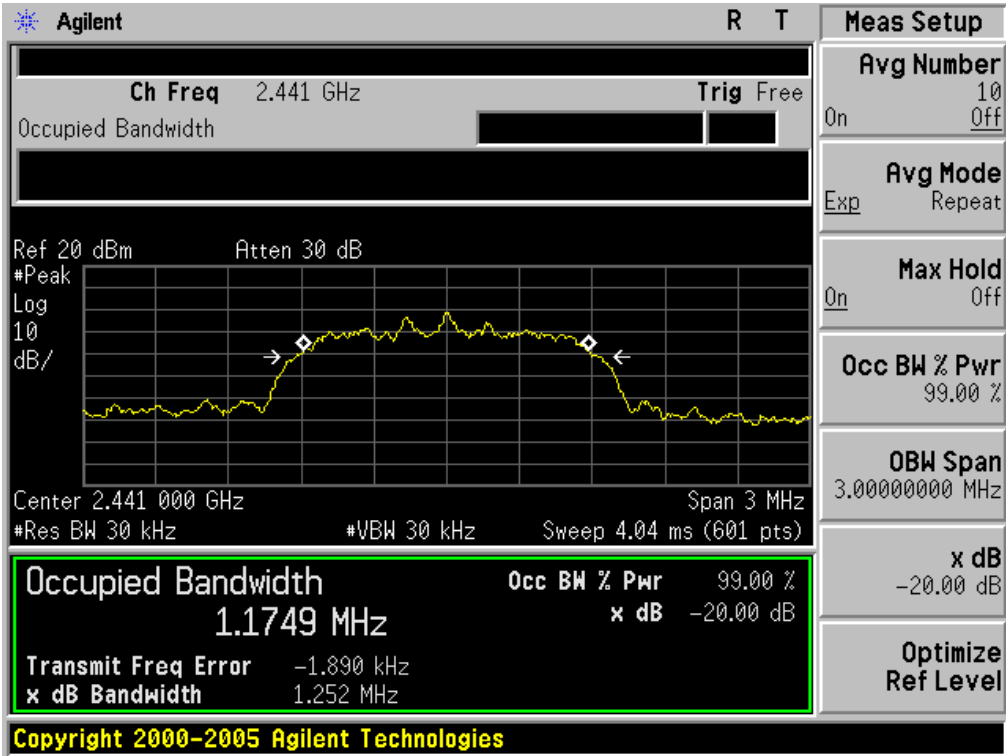

TEST PLOT OF BANDWIDTH FOR HIGH CHANNEL

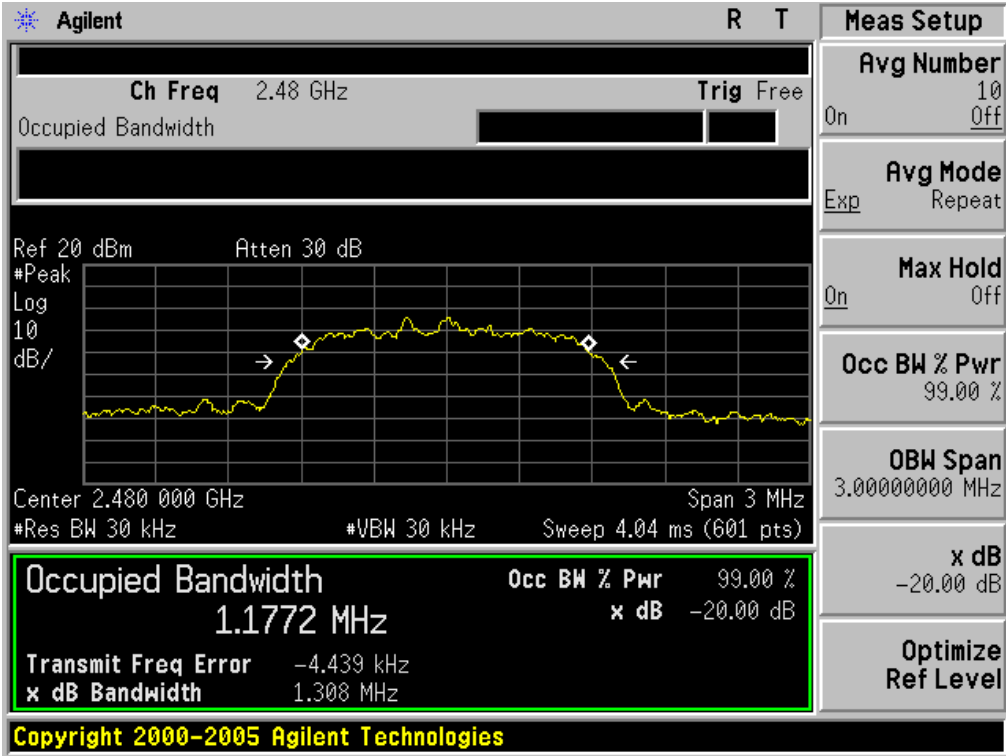

| BLUETOOTH 3MBPS LIMITS AND MEASUREMENT RESULT | | | |
|---|--------------------|-------|----------|
| Applicable Limits | Measurement Result | | |
| | Test Data (MHz) | | Criteria |
| N/A | Low Channel | 1.286 | PASS |
| | Middle Channel | 1.274 | PASS |
| | High Channel | 1.266 | PASS |

TEST PLOT OF BANDWIDTH FOR LOW CHANNEL

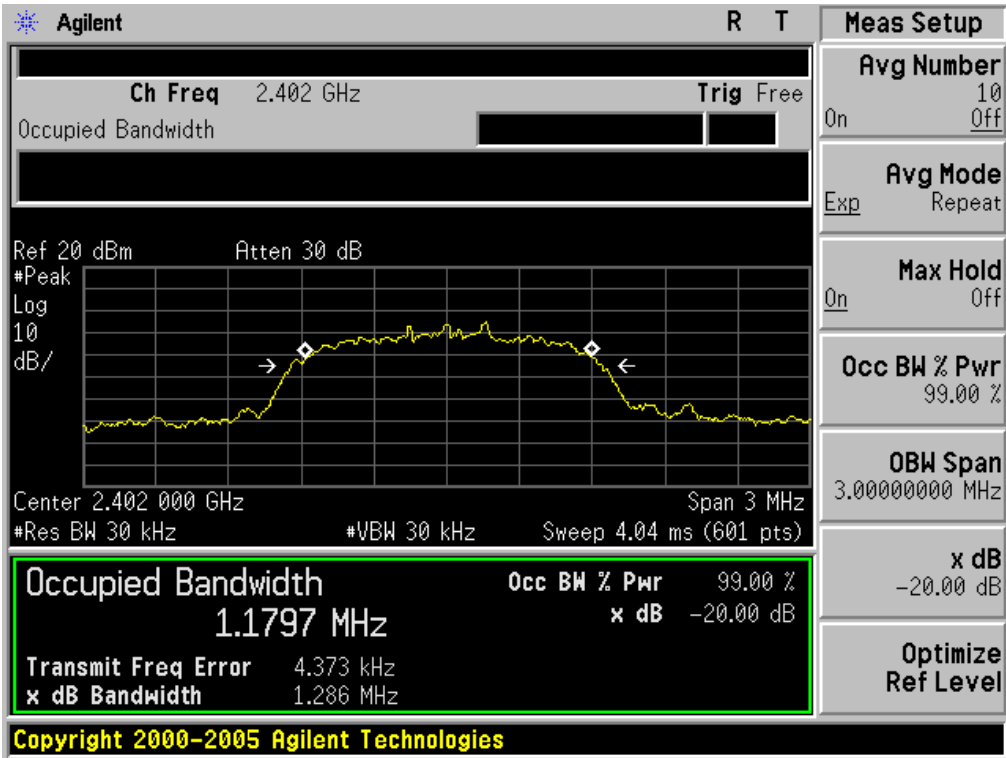

TEST PLOT OF BANDWIDTH FOR MIDDLE CHANNEL

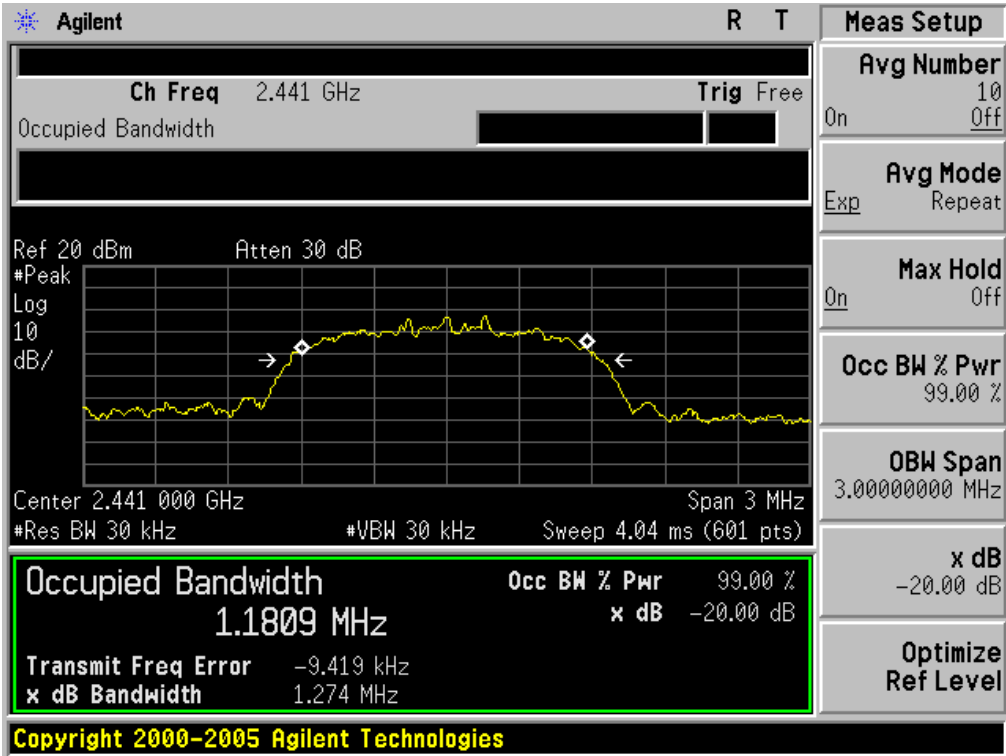

TEST PLOT OF BANDWIDTH FOR HIGH CHANNEL

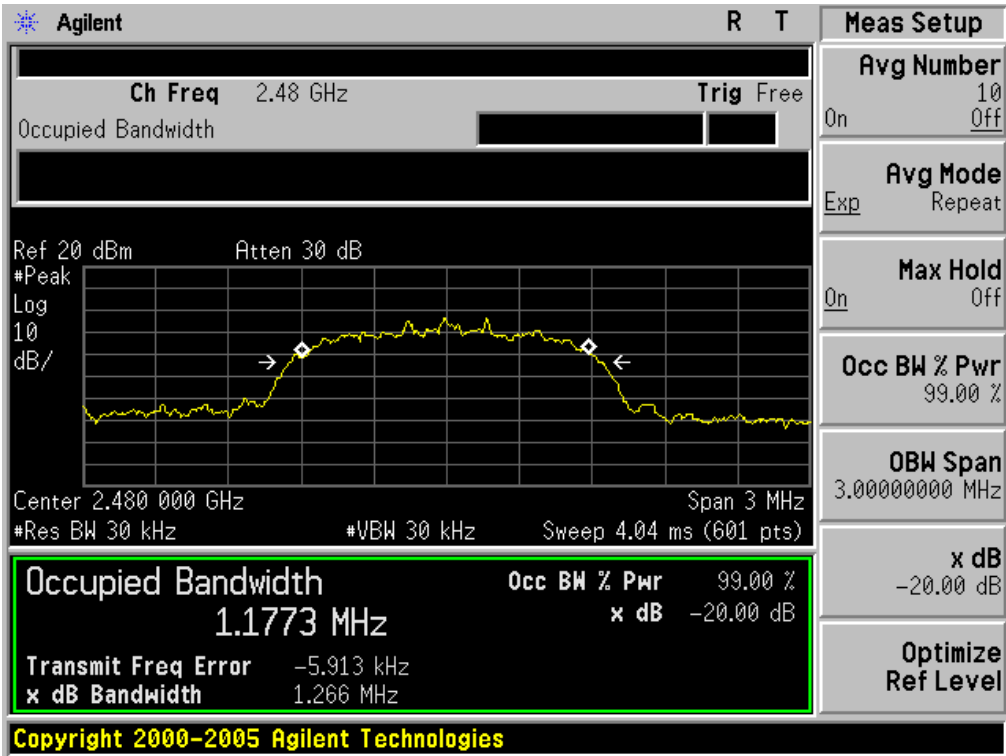

FOR BLE

| BLUETOOTH 1MBPS LIMITS AND MEASUREMENT RESULT | | | |
|---|--------------------|-------|----------|
| Applicable Limits | Measurement Result | | |
| | Test Data (MHz) | | Criteria |
| N/A | Low Channel | 1.208 | PASS |
| | Middle Channel | 1.200 | PASS |
| | High Channel | 1.194 | PASS |

TEST PLOT OF BANDWIDTH FOR LOW CHANNEL

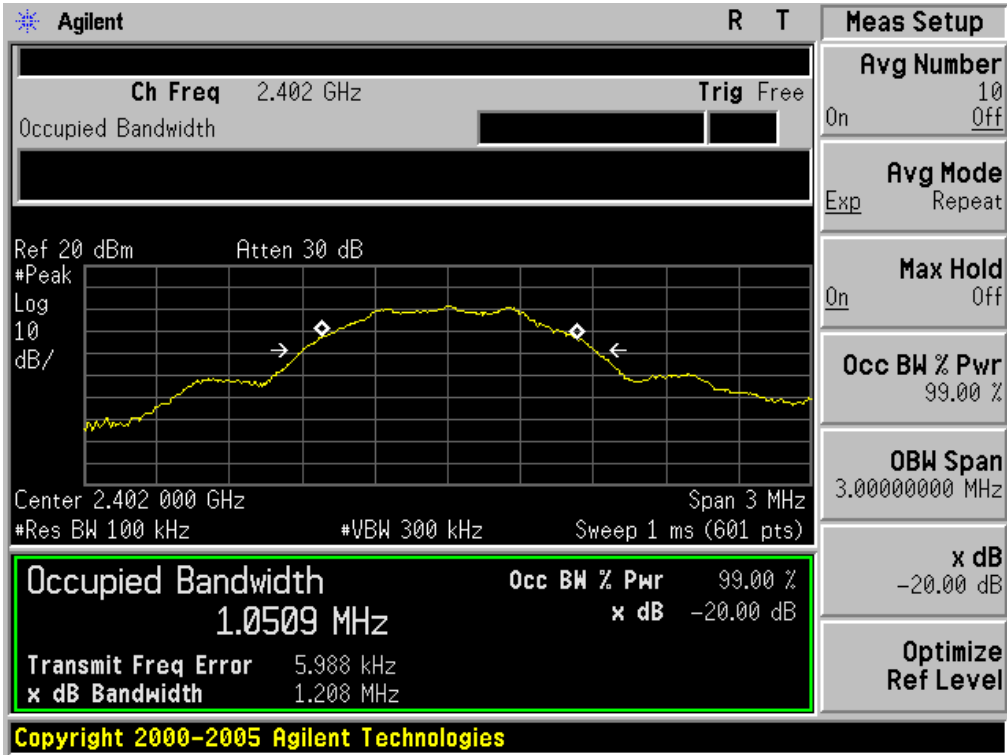

TEST PLOT OF BANDWIDTH FOR MIDDLE CHANNEL

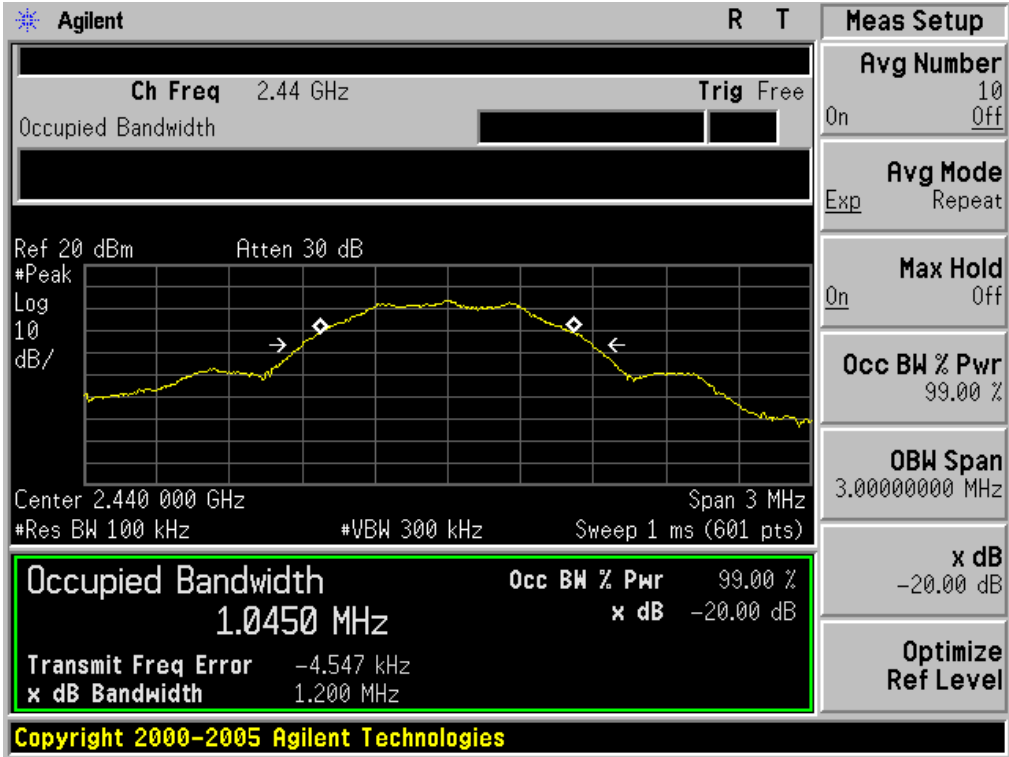

TEST PLOT OF BANDWIDTH FOR HIGH CHANNEL

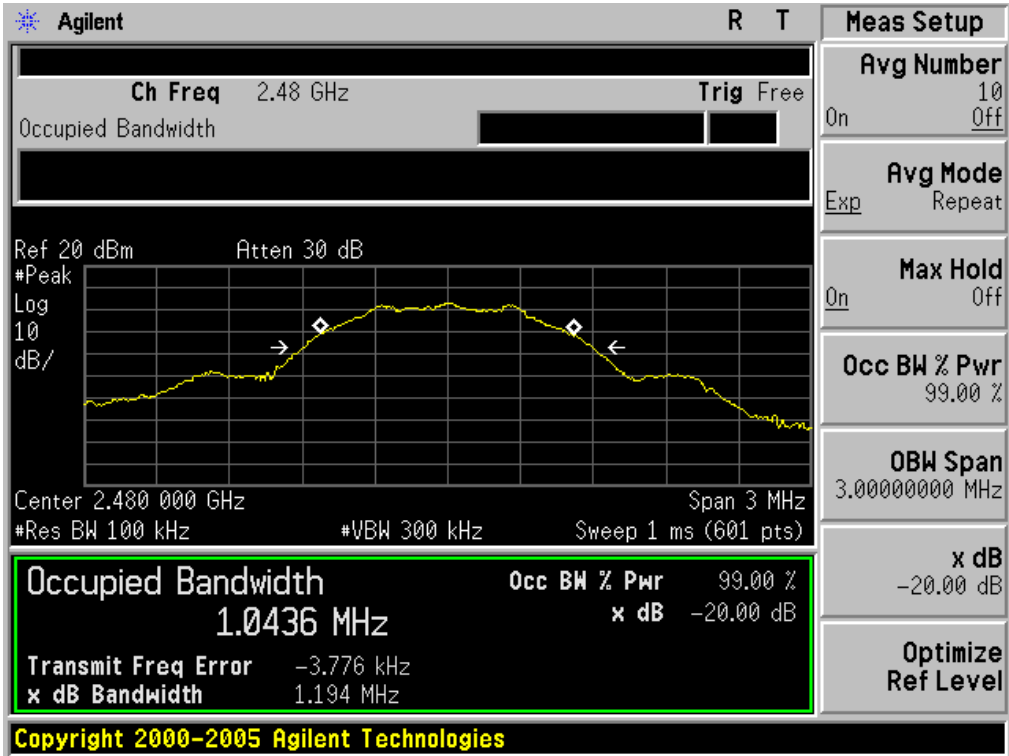

11. FCC LINE CONDUCTED EMISSION TEST

11.1. LIMITS OF LINE CONDUCTED EMISSION TEST

| Frequency | Maximum RF Line Voltage | |
|---------------|-------------------------|----------------|
| | Q.P.(dBuV) | Average(dBuV) |
| 150kHz~500kHz | 66-56 | 56-46 |
| 500kHz~5MHz | 56 | 46 |
| 5MHz~30MHz | 60 | 50 |

Note:

1. The lower limit shall apply at the transition frequency.
2. The limit decreases linearly with the logarithm of the frequency in the range 0.15 MHz to 0.50 MHz.

11.2. BLOCK DIAGRAM OF LINE CONDUCTED EMISSION TEST

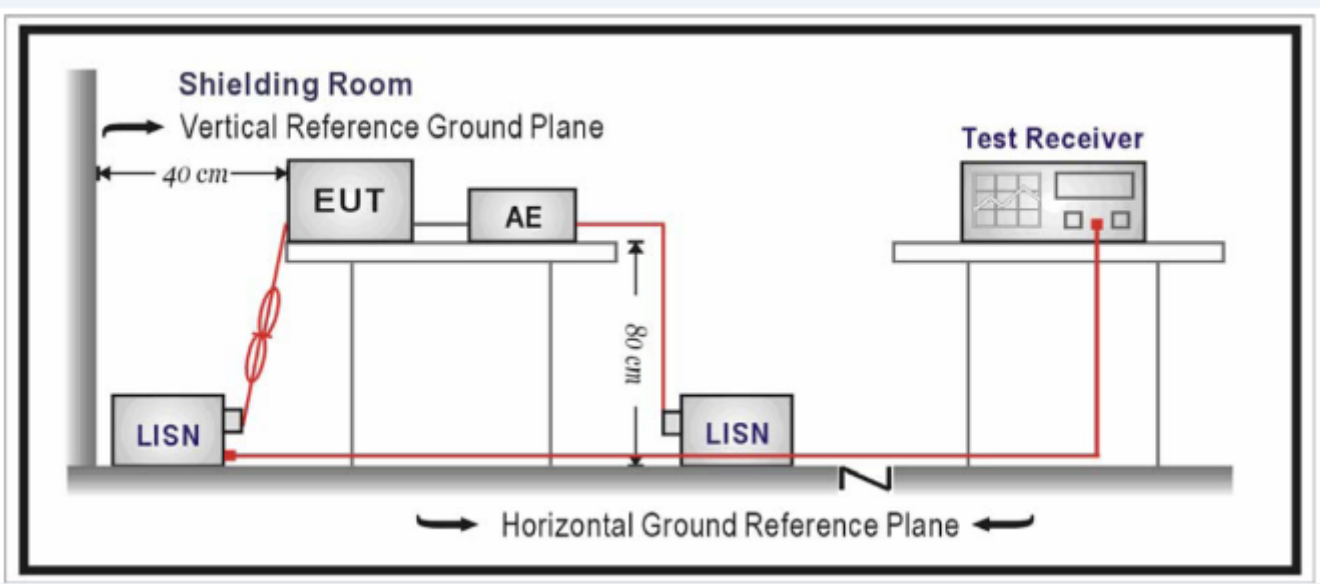

11.3. PRELIMINARY PROCEDURE OF LINE CONDUCTED EMISSION TEST

1. The equipment was set up as per the test configuration to simulate typical actual usage per the user's manual. When the EUT is a tabletop system, a wooden table with a height of 0.8 meters is used and is placed on the ground plane as per ANSI C63.4 (see Test Facility for the dimensions of the ground plane used). When the EUT is a floor-standing equipment, it is placed on the ground plane which has a 3-12 mm non-conductive covering to insulate the EUT from the ground plane.
2. Support equipment, if needed, was placed as per ANSI C63.4.
3. All I/O cables were positioned to simulate typical actual usage as per ANSI C63.4.
4. All support equipments received AC120V/60Hz power from a LISN, if any.
5. The EUT received DC voltage by PC which received 120V/60Hz power by a LISN..
6. The test program was started. Emissions were measured on each current carrying line of the EUT using a spectrum Analyzer / Receiver connected to the LISN powering the EUT. The LISN has two monitoring points: Line 1 (Hot Side) and Line 2 (Neutral Side). Two scans were taken: one with Line 1 connected to Analyzer / Receiver and Line 2 connected to a 50 ohm load; the second scan had Line 1 connected to a 50 ohm load and Line 2 connected to the Analyzer / Receiver.
7. Analyzer / Receiver scanned from 150 kHz to 30MHz for emissions in each of the test modes.
8. During the above scans, the emissions were maximized by cable manipulation.
9. The test mode(s) were scanned during the preliminary test.

Then, the EUT configuration and cable configuration of the above highest emission level were recorded for reference of final testing.

11.4. FINAL PROCEDURE OF LINE CONDUCTED EMISSION TEST

- EUT and support equipment was set up on the test bench as per step 2 of the preliminary test.
2. A scan was taken on both power lines, Line 1 and Line 2, recording at least the six highest emissions. Emission frequency and amplitude were recorded into a computer in which correction factors were used to calculate the emission level and compare reading to the applicable limit. If EUT emission level was less -2dB to the A.V. limit in Peak mode, then the emission signal was re-checked using Q.P and Average detector.
3. The test data of the worst case condition(s) was reported on the Summary Data page.

**11.5. TEST RESULT OF LINE CONDUCTED EMISSION TEST
 FOR BR/EDR BLUETOOTH**

Line Conducted Emission Test Line 1-L

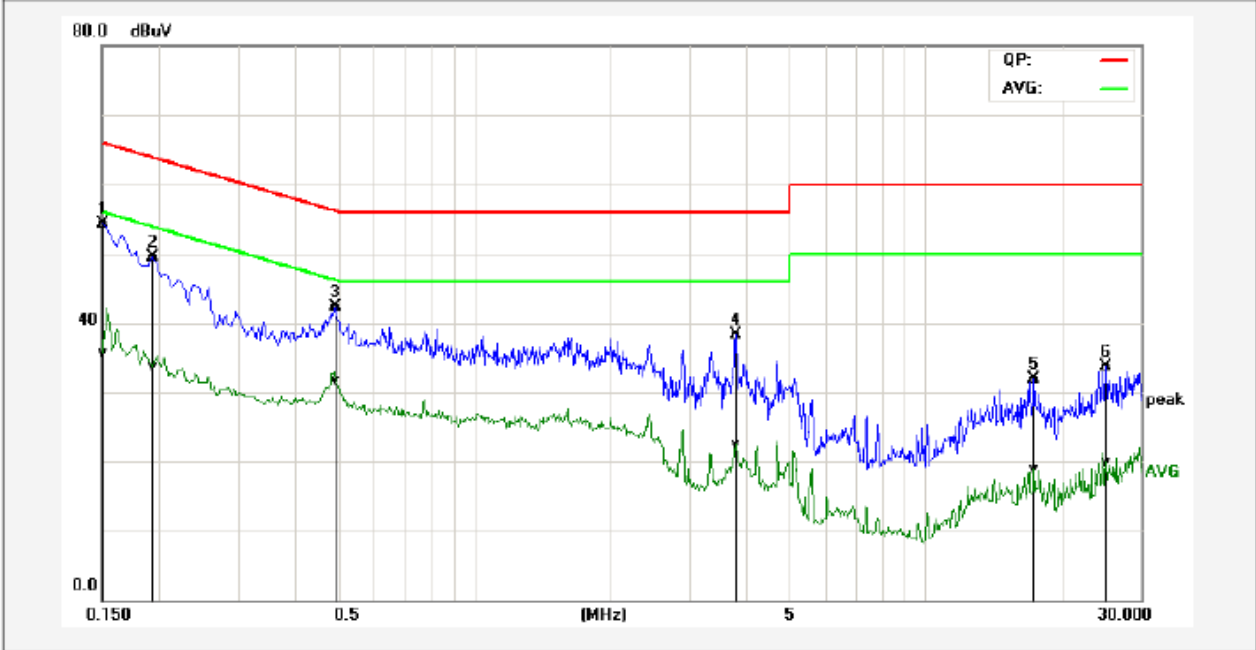

| No. | Frequency (MHz) | QuasiPeak reading (dBuV) | Average reading (dBuV) | Correction factor (dB) | QuasiPeak result (dBuV) | Average result (dBuV) | QuasiPeak limit (dBuV) | Average limit (dBuV) | QuasiPeak margin (dB) | Average margin (dB) | Remark |
|-----|--------------------|--------------------------------|------------------------------|------------------------------|-------------------------------|-----------------------------|------------------------------|----------------------------|-----------------------------|---------------------------|--------|
| 1* | 0.1500 | 44.76 | 26.12 | 9.58 | 54.34 | 35.70 | 65.99 | 56.00 | -11.65 | -20.30 | Pass |
| 2P | 0.1940 | 39.90 | 24.12 | 9.68 | 49.58 | 33.80 | 63.86 | 53.86 | -14.28 | -20.06 | Pass |
| 3P | 0.4940 | 32.57 | 22.08 | 9.68 | 42.25 | 31.76 | 56.10 | 46.10 | -13.85 | -14.34 | Pass |
| 4P | 3.8020 | 28.58 | 12.78 | 9.70 | 38.28 | 22.48 | 56.00 | 46.00 | -17.72 | -23.52 | Pass |
| 5P | 17.4260 | 21.95 | 9.01 | 9.87 | 31.82 | 18.88 | 60.00 | 50.00 | -28.18 | -31.12 | Pass |
| 6P | 25.1460 | 23.84 | 10.07 | 9.89 | 33.73 | 19.96 | 60.00 | 50.00 | -26.27 | -30.04 | Pass |

| No. | Frequency (MHz) | QuasiPeak reading (dBuV) | Average reading (dBuV) | Correction factor (dB) | QuasiPeak result (dBuV) | Average result (dBuV) | QuasiPeak limit (dBuV) | Average limit (dBuV) | QuasiPeak margin (dB) | Average margin (dB) | Remark |
|-----|--------------------|--------------------------------|------------------------------|------------------------------|-------------------------------|-----------------------------|------------------------------|----------------------------|-----------------------------|---------------------------|--------|
| 1* | 0.1539 | 43.24 | 30.14 | 9.78 | 53.02 | 39.92 | 65.78 | 55.79 | -12.76 | -15.87 | Pass |
| 2P | 0.2340 | 35.95 | 21.97 | 9.78 | 45.73 | 31.75 | 62.30 | 52.31 | -16.57 | -20.56 | Pass |
| 3P | 0.4780 | 31.74 | 20.91 | 9.69 | 41.43 | 30.60 | 56.37 | 46.37 | -14.94 | -15.77 | Pass |
| 4P | 1.4580 | 28.93 | 16.69 | 9.77 | 38.70 | 26.46 | 56.00 | 46.00 | -17.30 | -19.54 | Pass |
| 5P | 3.8460 | 27.07 | 13.54 | 9.76 | 36.83 | 23.30 | 56.00 | 46.00 | -19.17 | -22.70 | Pass |

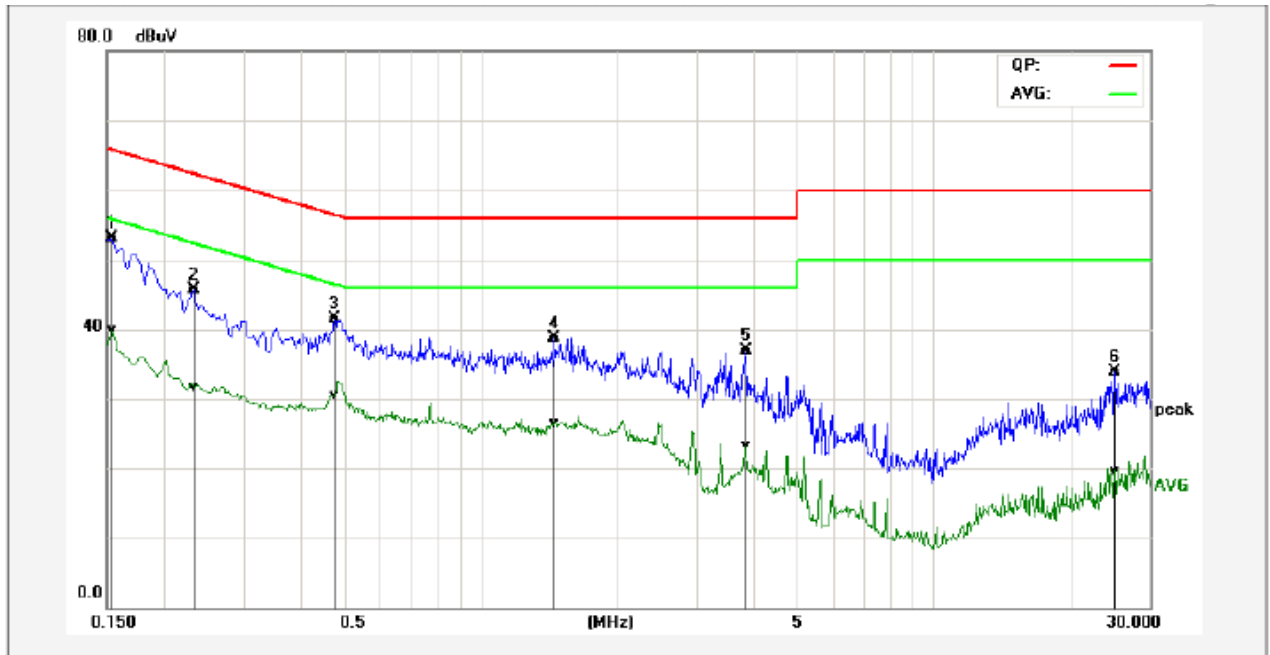

| No. | Frequency (MHz) | QuasiPeak reading (dBuV) | Average reading (dBuV) | Correction factor (dB) | QuasiPeak result (dBuV) | Average result (dBuV) | QuasiPeak limit (dBuV) | Average limit (dBuV) | QuasiPeak margin (dB) | Average margin (dB) | Remark |
|-----|--------------------|--------------------------------|------------------------------|------------------------------|-------------------------------|-----------------------------|------------------------------|----------------------------|-----------------------------|---------------------------|--------|
| 1* | 0.1539 | 43.24 | 30.14 | 9.78 | 53.02 | 39.92 | 65.78 | 55.79 | -12.76 | -15.87 | Pass |
| 2P | 0.2340 | 35.95 | 21.97 | 9.78 | 45.73 | 31.75 | 62.30 | 52.31 | -16.57 | -20.56 | Pass |
| 3P | 0.4780 | 31.74 | 20.91 | 9.69 | 41.43 | 30.60 | 56.37 | 46.37 | -14.94 | -15.77 | Pass |
| 4P | 1.4580 | 28.93 | 16.69 | 9.77 | 38.70 | 26.46 | 56.00 | 46.00 | -17.30 | -19.54 | Pass |
| 5P | 3.8460 | 27.07 | 13.54 | 9.76 | 36.83 | 23.30 | 56.00 | 46.00 | -19.17 | -22.70 | Pass |
| 6P | 25.1180 | 24.03 | 9.97 | 9.79 | 33.82 | 19.76 | 60.00 | 50.00 | -26.18 | -30.24 | Pass |

FOR BLE

Line Conducted Emission Test Line 1-L

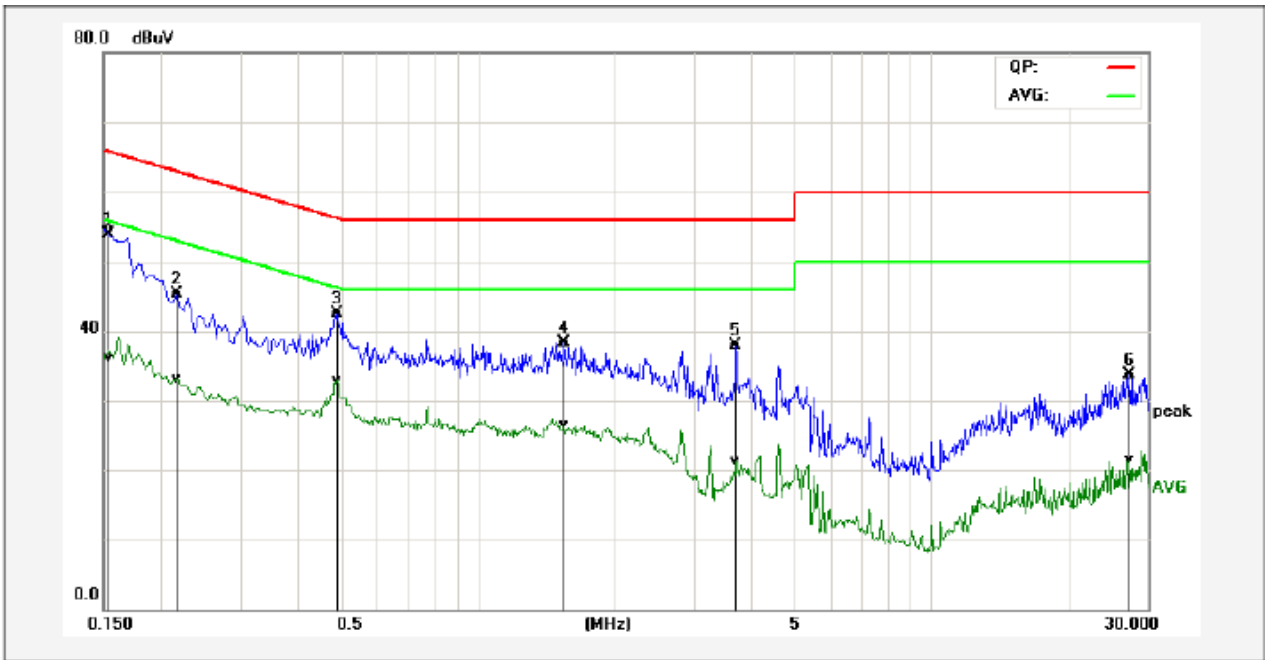

| No. | Frequency (MHz) | QuasiPeak reading (dBuV) | Average reading (dBuV) | Correction factor (dB) | QuasiPeak result (dBuV) | Average result (dBuV) | QuasiPeak limit (dBuV) | Average limit (dBuV) | QuasiPeak margin (dB) | Average margin (dB) | Remark |
|-----|--------------------|--------------------------------|------------------------------|------------------------------|-------------------------------|-----------------------------|------------------------------|----------------------------|-----------------------------|---------------------------|--------|
| 1* | 0.1548 | 45.18 | 26.60 | 9.59 | 54.77 | 36.19 | 65.73 | 55.74 | -10.96 | -19.55 | Pass |
| 2P | 0.2180 | 35.59 | 23.48 | 9.69 | 45.28 | 33.17 | 62.89 | 52.89 | -17.61 | -19.72 | Pass |
| 3P | 0.4900 | 32.87 | 23.29 | 9.68 | 42.55 | 32.97 | 56.17 | 46.17 | -13.62 | -13.20 | Pass |
| 4P | 1.5580 | 28.54 | 16.71 | 9.72 | 38.26 | 26.43 | 56.00 | 46.00 | -17.74 | -19.57 | Pass |
| 5P | 3.7060 | 28.17 | 11.52 | 9.70 | 37.87 | 21.22 | 56.00 | 46.00 | -18.13 | -24.78 | Pass |
| 6P | 27.3540 | 23.81 | 11.54 | 9.94 | 33.75 | 21.48 | 60.00 | 50.00 | -26.25 | -28.52 | Pass |

Line Conducted Emission Test Line 2-N

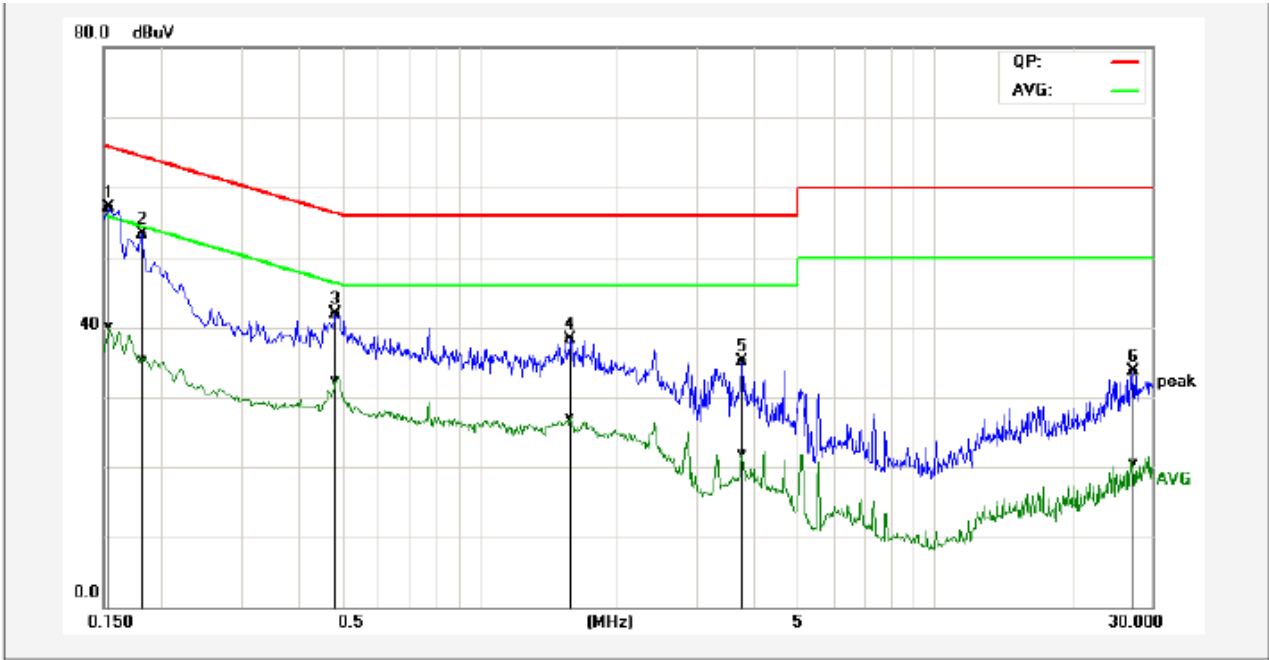

| No. | Frequency (MHz) | QuasiPeak reading (dBuV) | Average reading (dBuV) | Correction factor (dB) | QuasiPeak result (dBuV) | Average result (dBuV) | QuasiPeak limit (dBuV) | Average limit (dBuV) | QuasiPeak margin (dB) | Average margin (dB) | Remark |
|-----|-----------------|--------------------------|------------------------|------------------------|-------------------------|-----------------------|------------------------|----------------------|-----------------------|---------------------|--------|
| 1* | 0.1539 | 47.34 | 30.40 | 9.78 | 57.12 | 40.18 | 65.78 | 55.79 | -8.66 | -15.61 | Pass |
| 2P | 0.1819 | 43.52 | 25.57 | 9.79 | 53.31 | 35.36 | 64.39 | 54.40 | -11.08 | -19.04 | Pass |
| 3P | 0.4860 | 32.13 | 22.67 | 9.68 | 41.81 | 32.35 | 56.24 | 46.24 | -14.43 | -13.89 | Pass |
| 4P | 1.5859 | 28.56 | 17.35 | 9.76 | 38.32 | 27.11 | 56.00 | 46.00 | -17.68 | -18.89 | Pass |
| 5P | 3.7820 | 25.26 | 12.06 | 9.76 | 35.02 | 21.82 | 56.00 | 46.00 | -20.98 | -24.18 | Pass |
| 6P | 27.3580 | 23.77 | 10.62 | 9.84 | 33.61 | 20.46 | 60.00 | 50.00 | -26.39 | -29.54 | Pass |

APPENDIX A: PHOTOGRAPHS OF TEST SETUP
FCC LINE CONDUCTED EMISSION TEST SETUP



FCC RADIATED EMISSION TEST SETUP

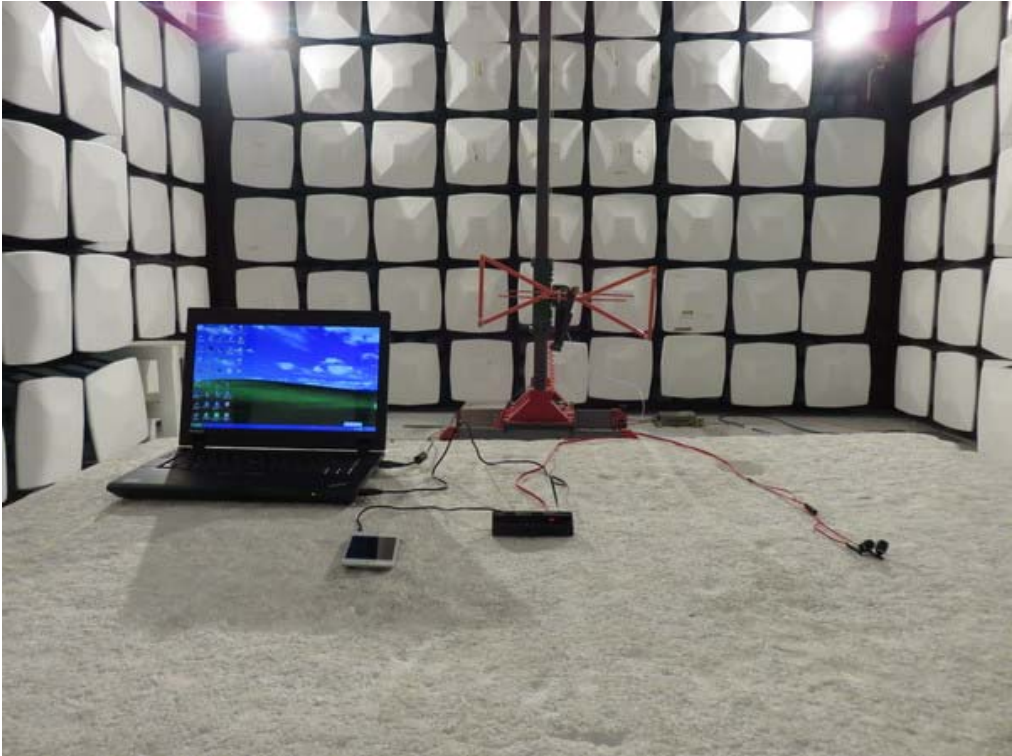



APPENDIX B: PHOTOGRAPHS OF EUT
All VIEW OF EUT



TOP VIEW OF EUT



BOTTOM VIEW OF EUT



FRONT VIEW OF EUT



BACK VIEW OF EUT



LEFT VIEW OF EUT



RIGHT VIEW OF EUT

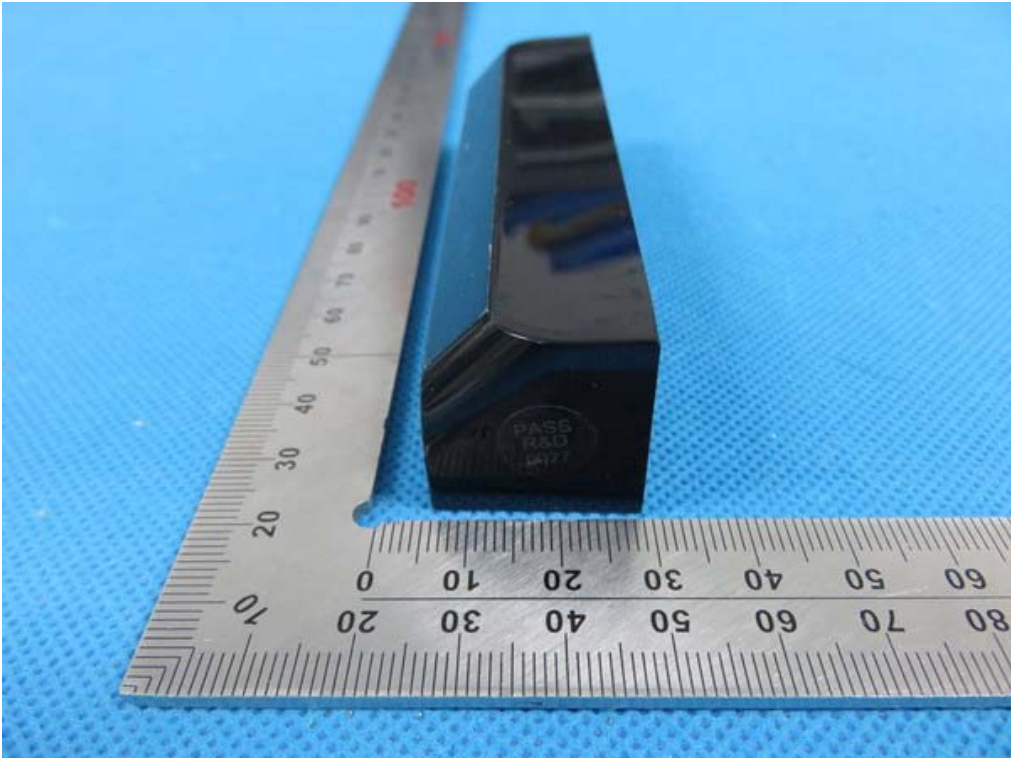

VIEW OF EUT (PORT)



OPEN VIEW OF EUT

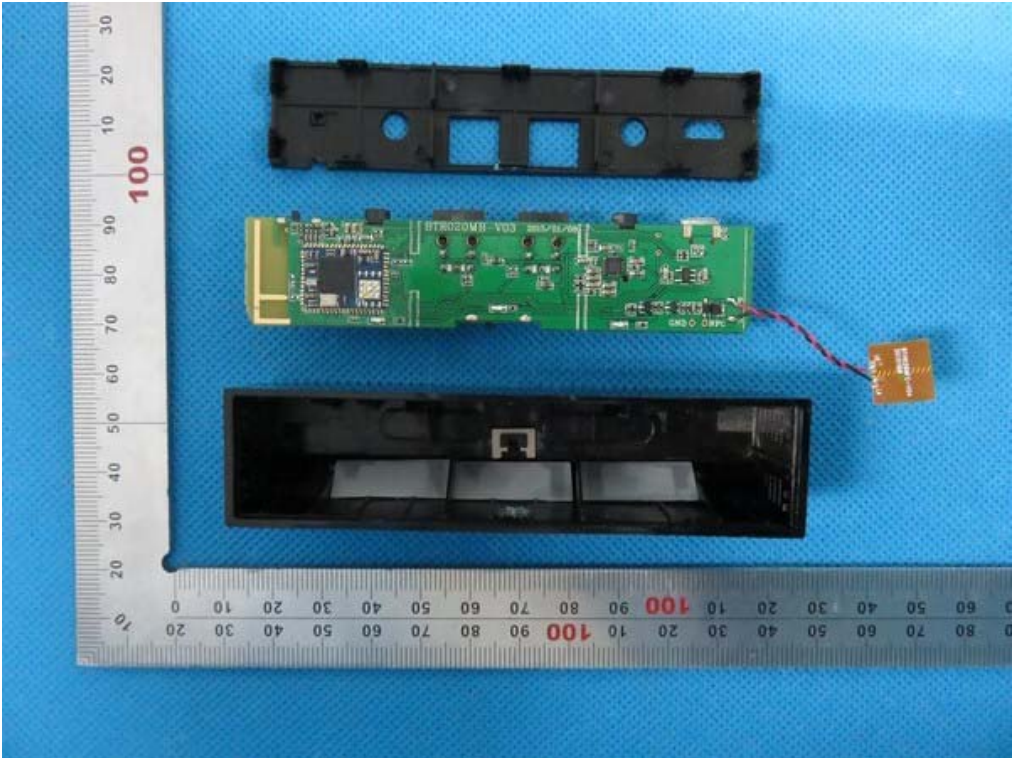

INTERNAL VIEW OF EUT-1

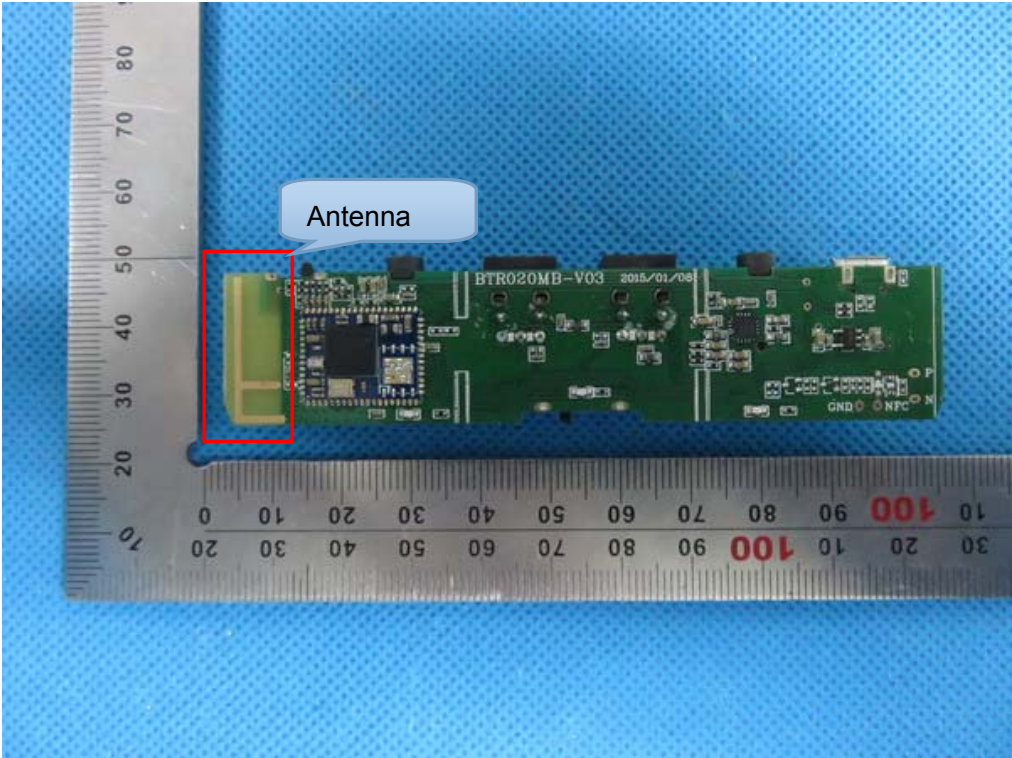

INTERNAL VIEW OF EUT-2

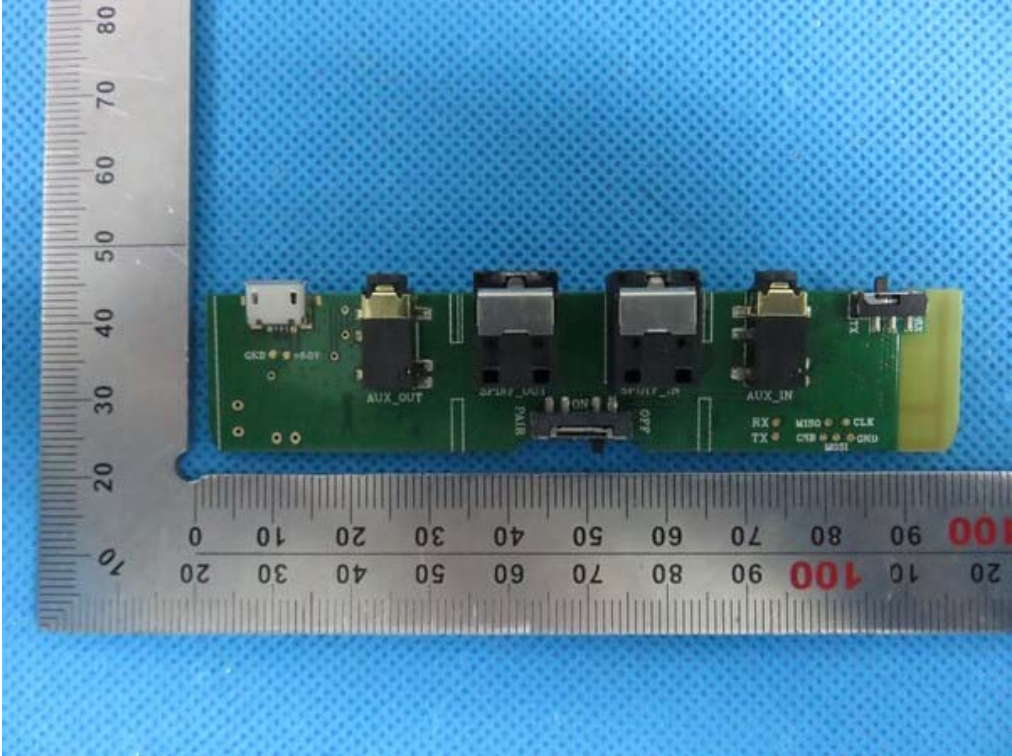

INTERNAL VIEW OF EUT-3

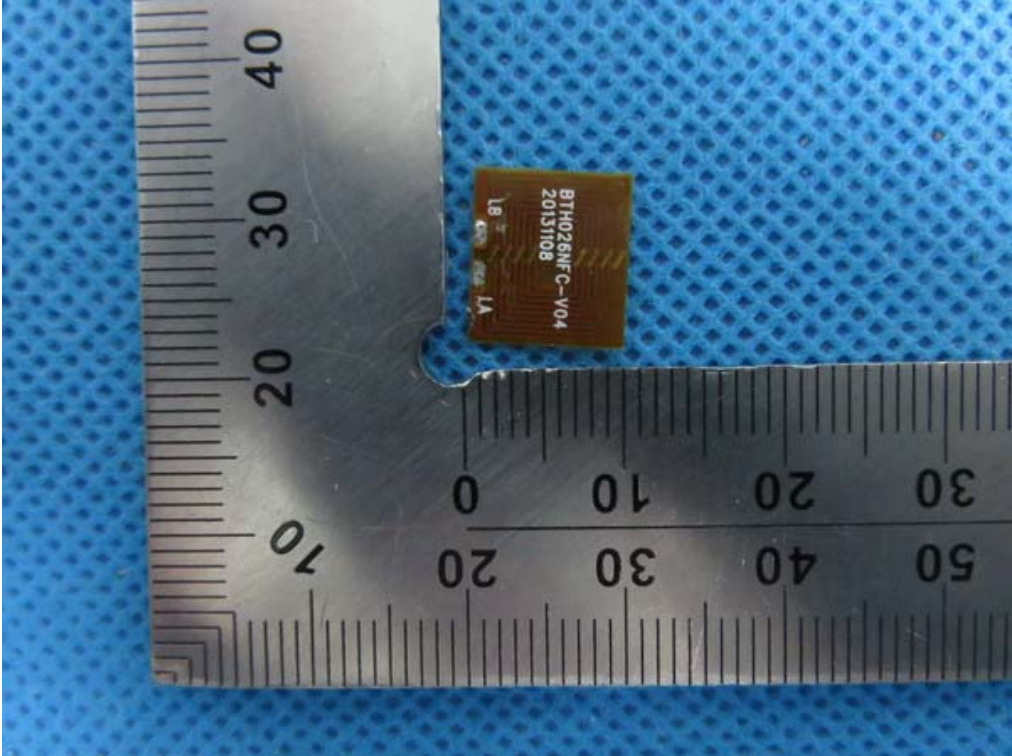

INTERNAL VIEW OF EUT-4

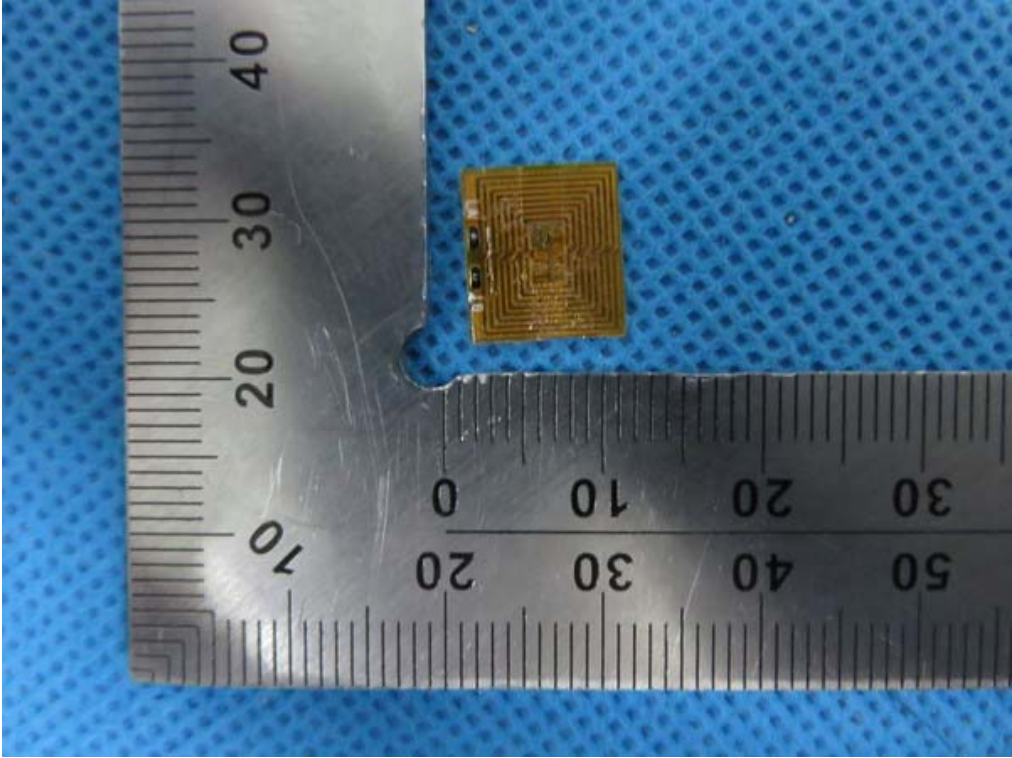

INTERNAL VIEW OF EUT-5

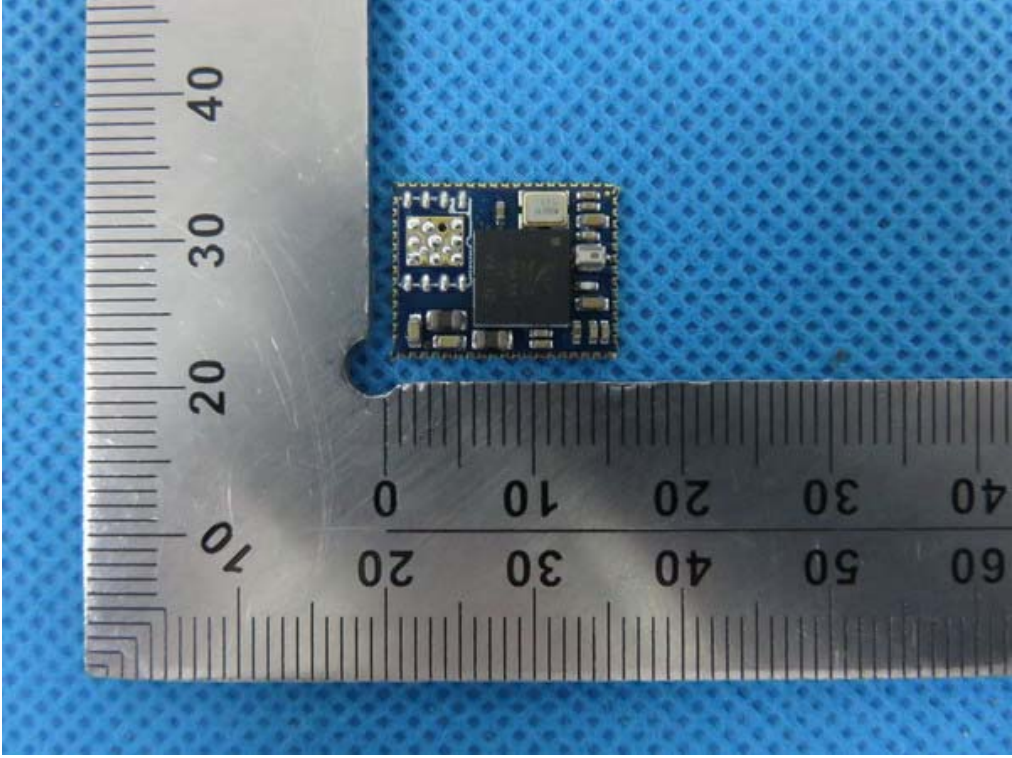

INTERNAL VIEW OF EUT-6

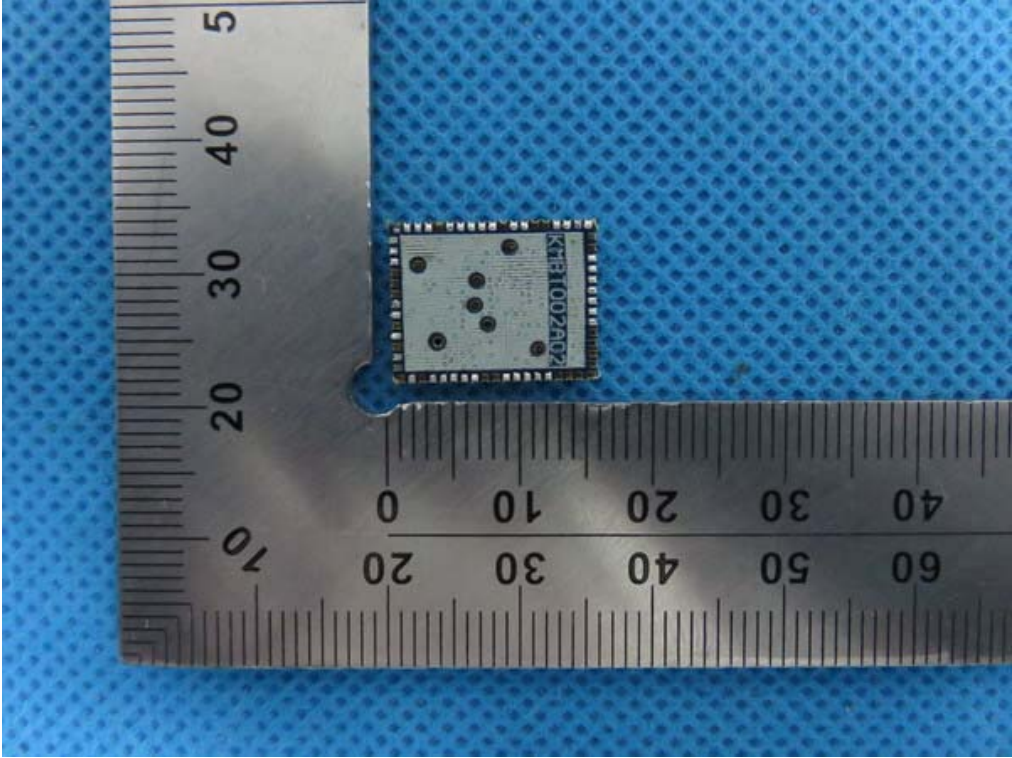

INTERNAL VIEW OF EUT-7

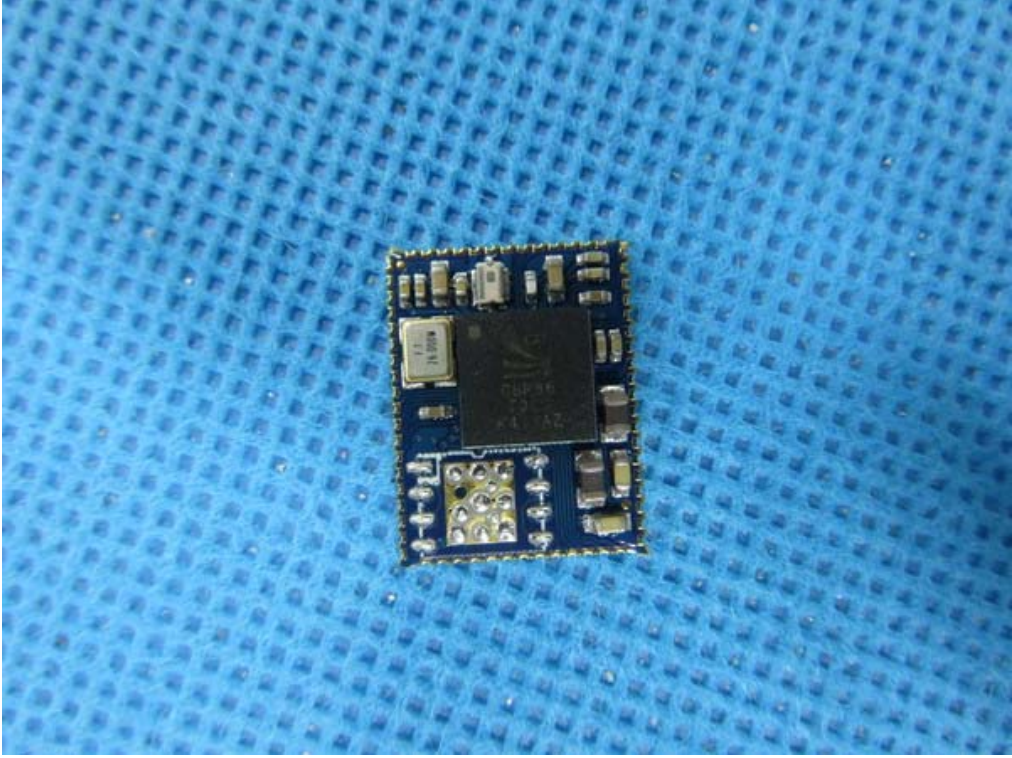

----END OF REPORT----