

Date: 14.MAR.2011 10:45:18

Figure 562: Radiated Emission at the Edge for Channel 5320 MHz at 6Mbps – Horz. (Ave.)

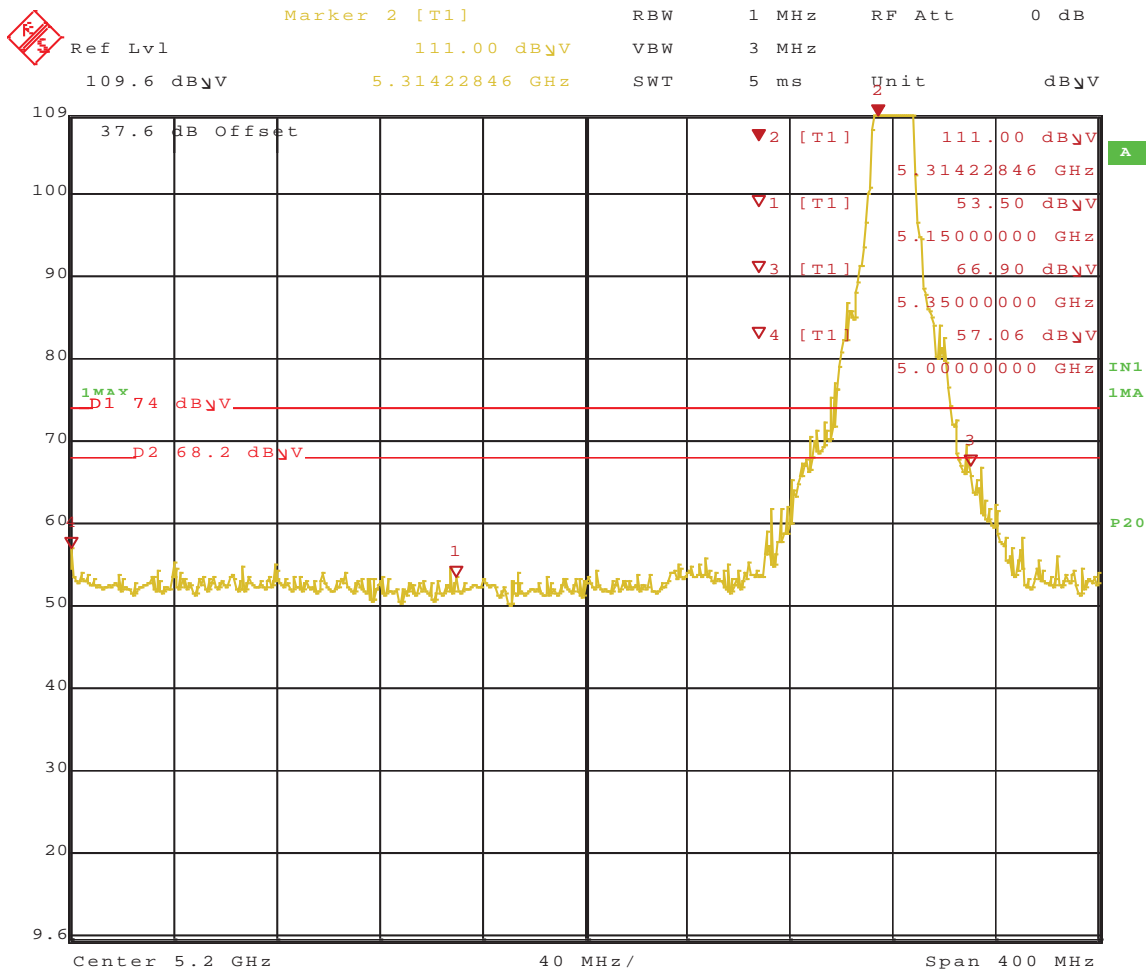

Date: 14.MAR.2011 10:35:16

Figure 563: Radiated Emission at the Edge for Channel 5320 MHz at 6Mbps – Vert. (Peak)

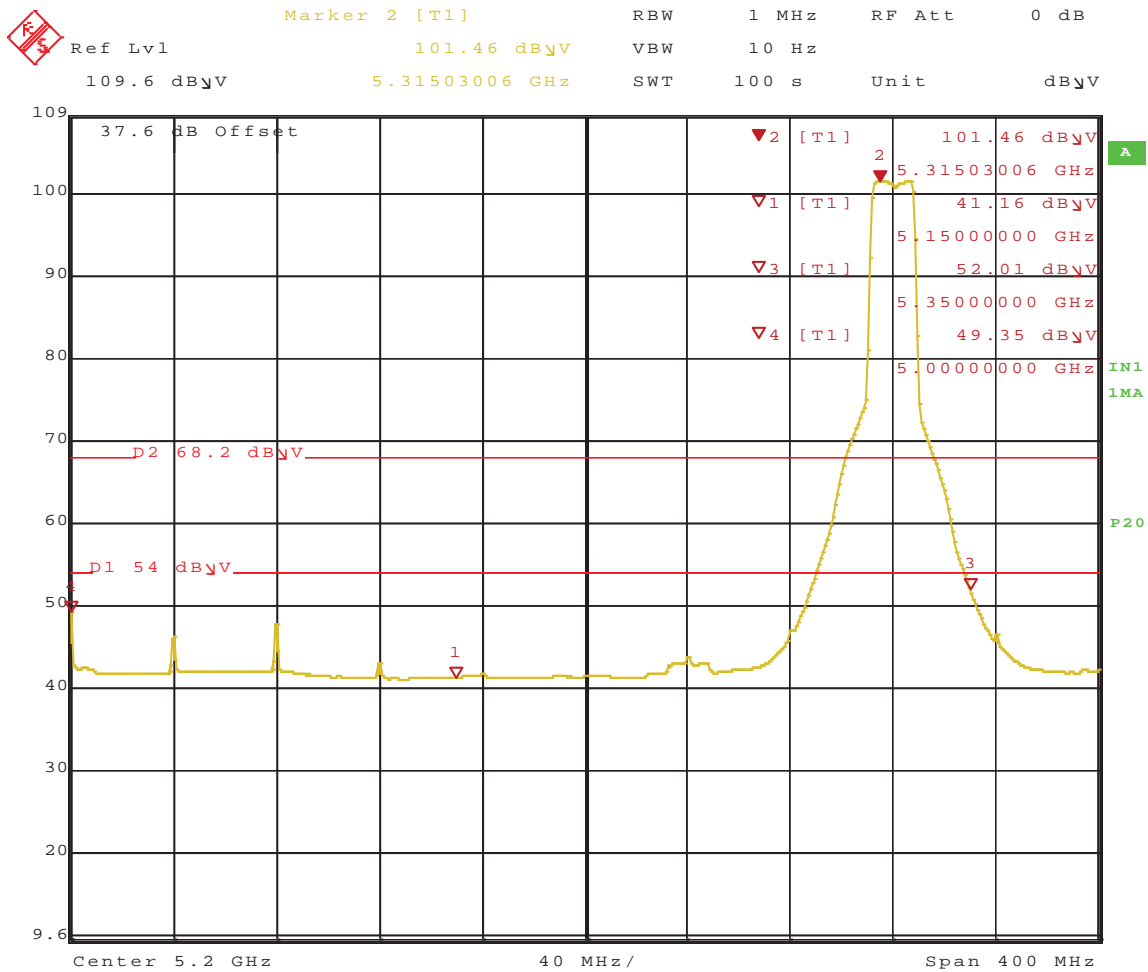

Date: 14.MAR.2011 10:37:59

Figure 564: Radiated Emission at the Edge for Channel 5320 MHz at 6Mbps – Vert. (Ave.)

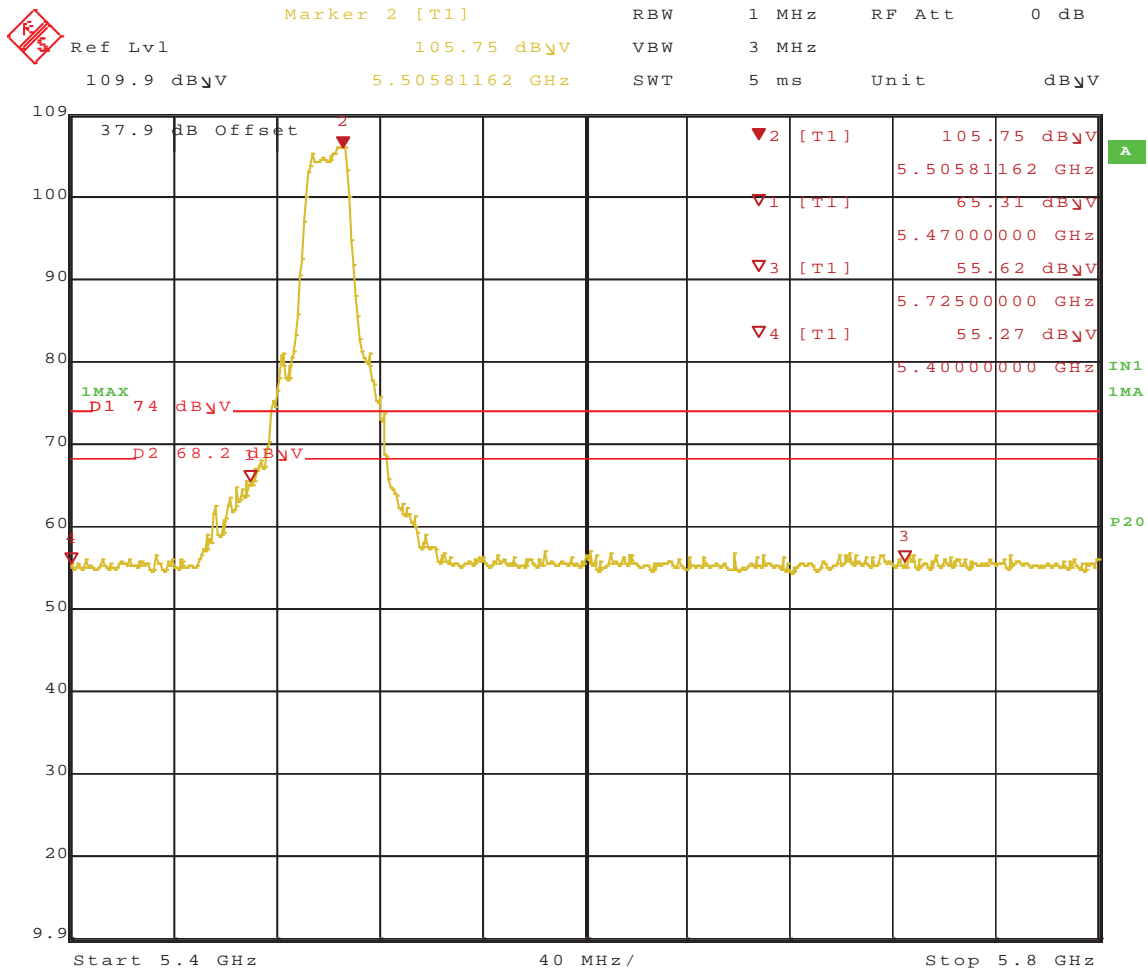

Date: 14.MAR.2011 10:54:05

Figure 565: Radiated Emission at the Edge for 5500 MHz at 6Mbps – Horz. (Peak)

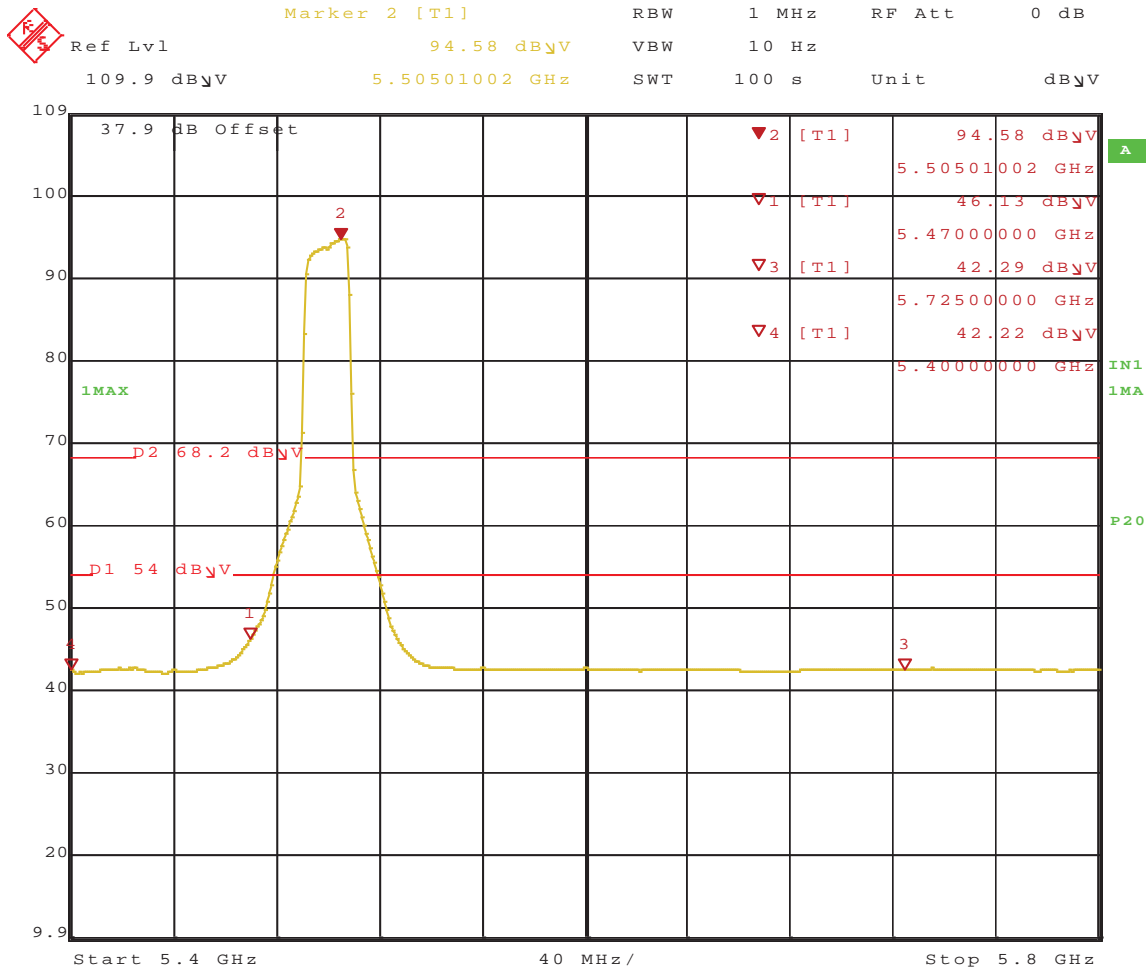

Date: 14.MAR.2011 10:52:08

Figure 566: Radiated Emission at the Edge for 5500 MHz at 6Mbps – Horz. (Ave.)

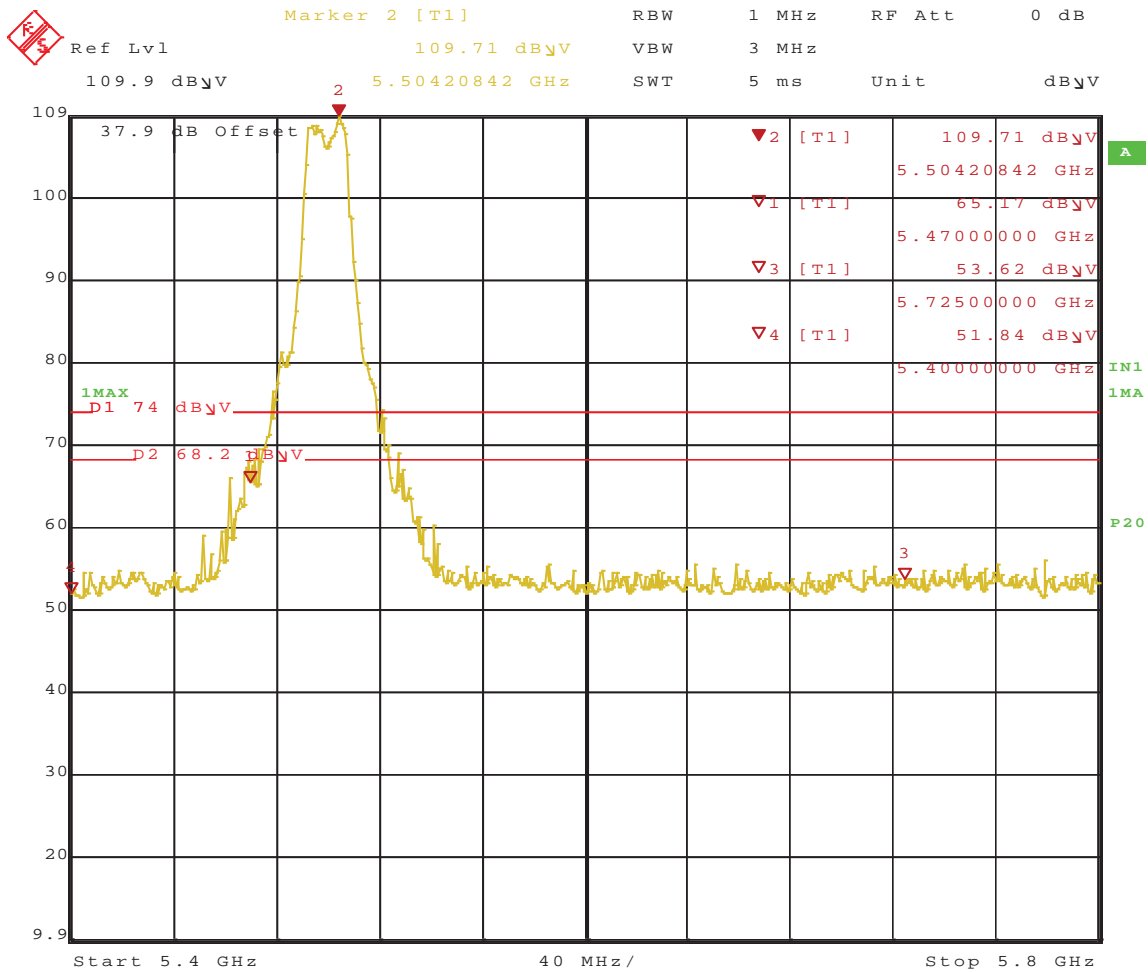

Date: 14.MAR.2011 10:57:23

Figure 567: Radiated Emission at the Edge for 5500 MHz at 6Mbps – Vert. (Peak)

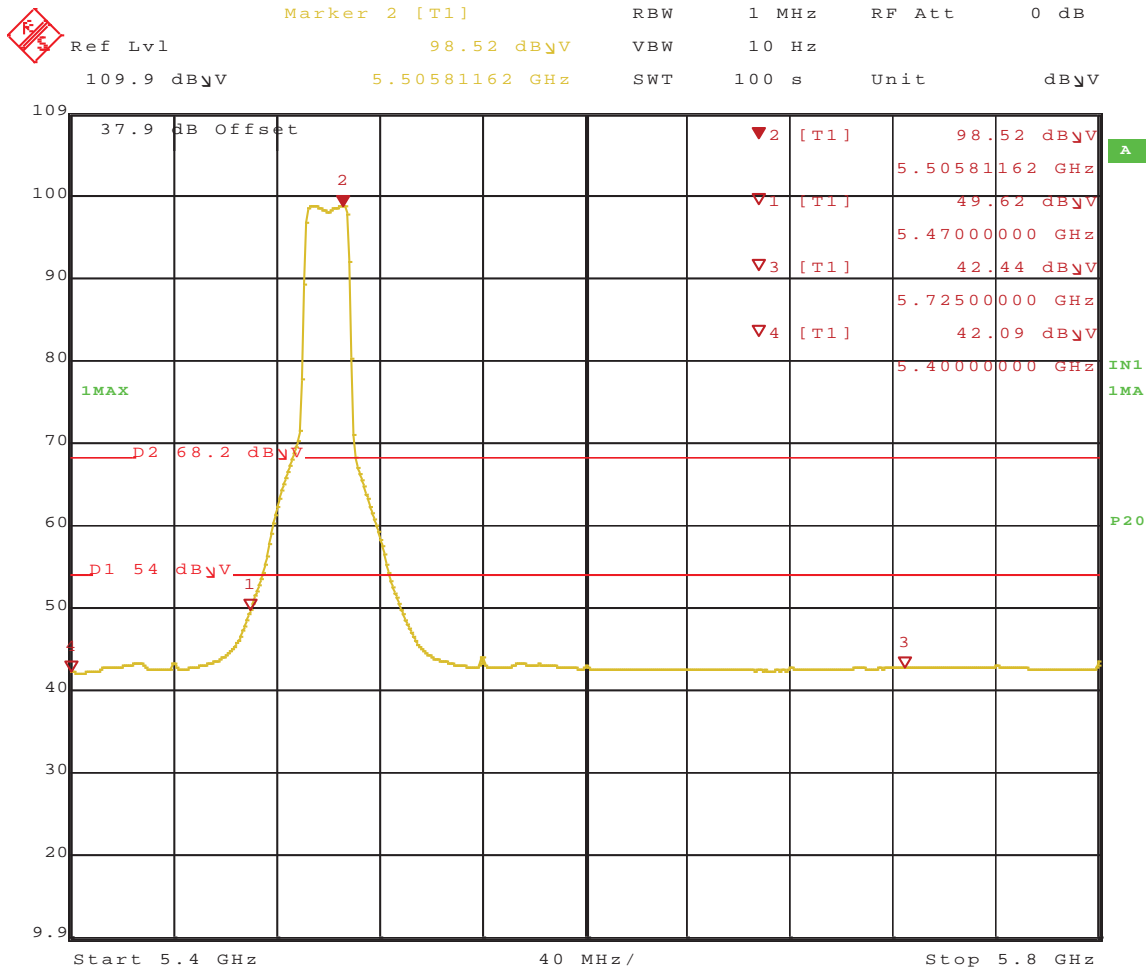

Date: 14.MAR.2011 11:00:30

Figure 568: Radiated Emission at the Edge for 5500 MHz at 6Mbps – Vert. (Ave.)

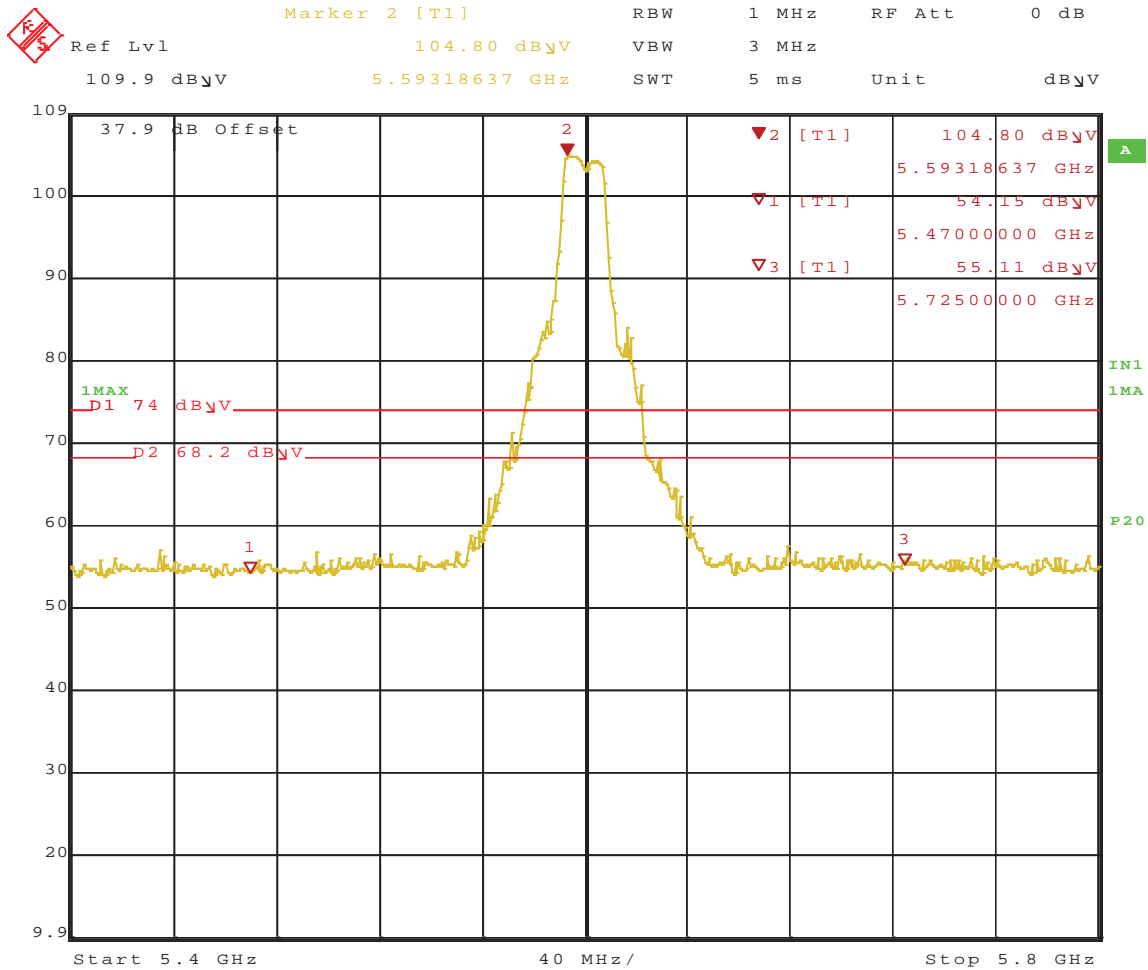

Date: 14.MAR.2011 12:07:32

Figure 569: Radiated Emission at the Edge for 5600 MHz at 6Mbps – Horiz. (Peak)

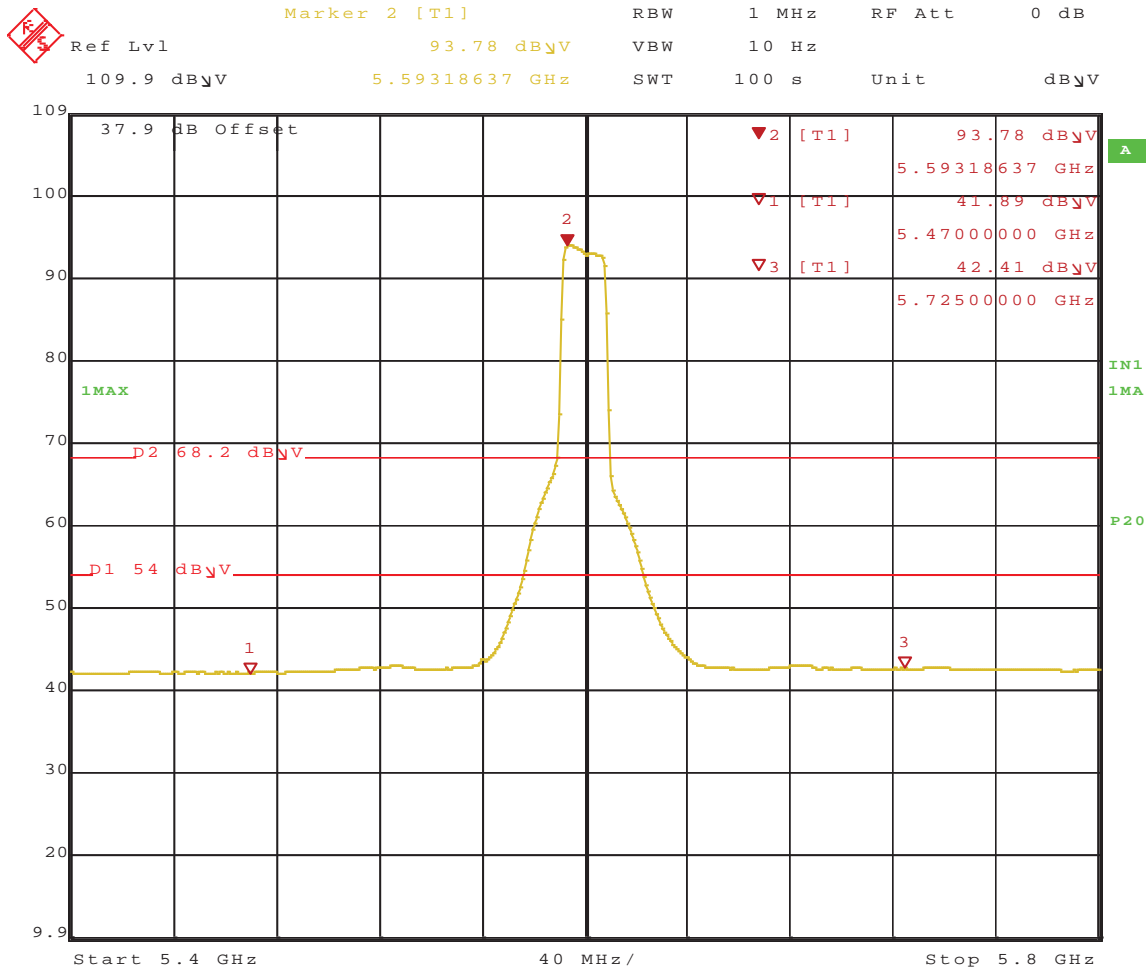

Date: 14.MAR.2011 12:09:51

Figure 570: Radiated Emission at the Edge for 5600 MHz at 6Mbps – Horz. (Ave.)

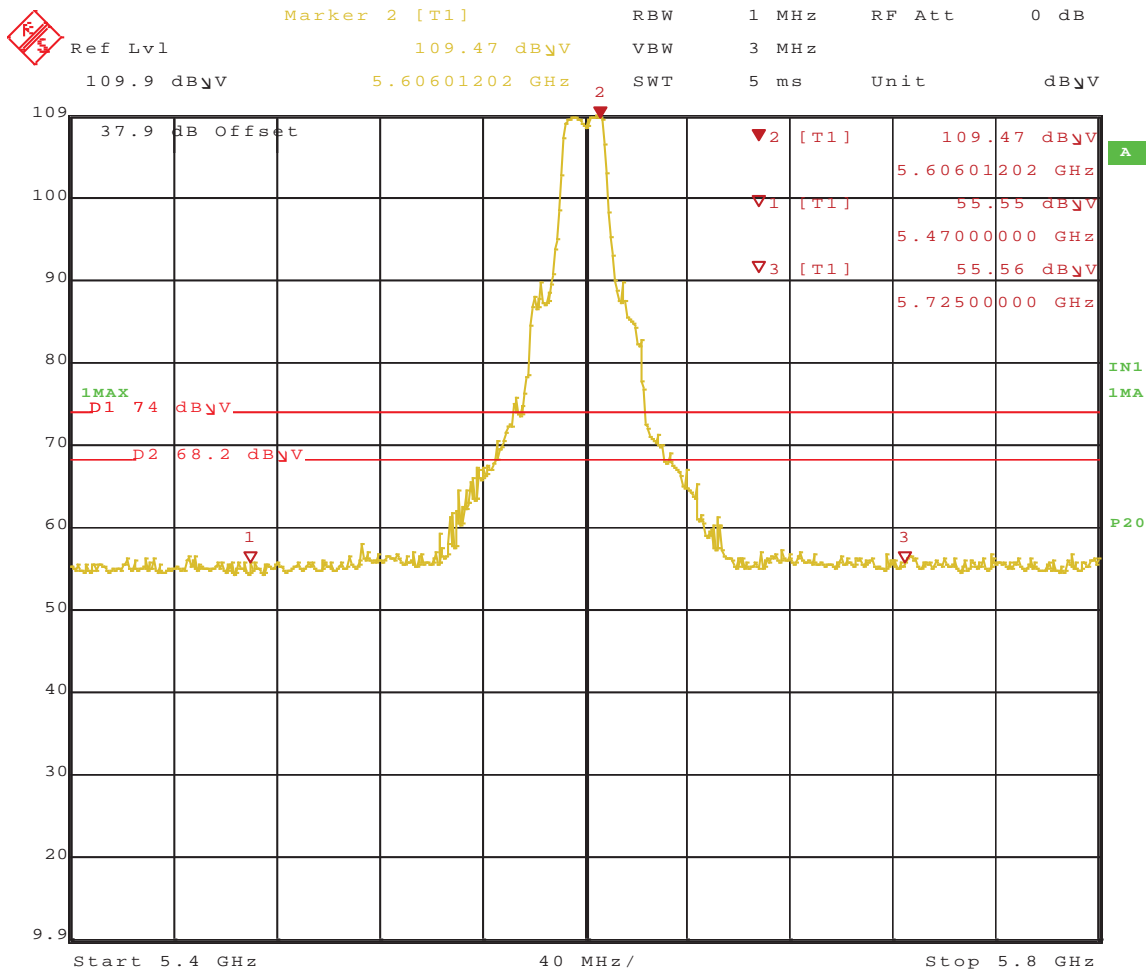

Date: 14.MAR.2011 11:08:41

Figure 571: Radiated Emission at the Edge for 5600 MHz at 6Mbps – Vert. (Peak)

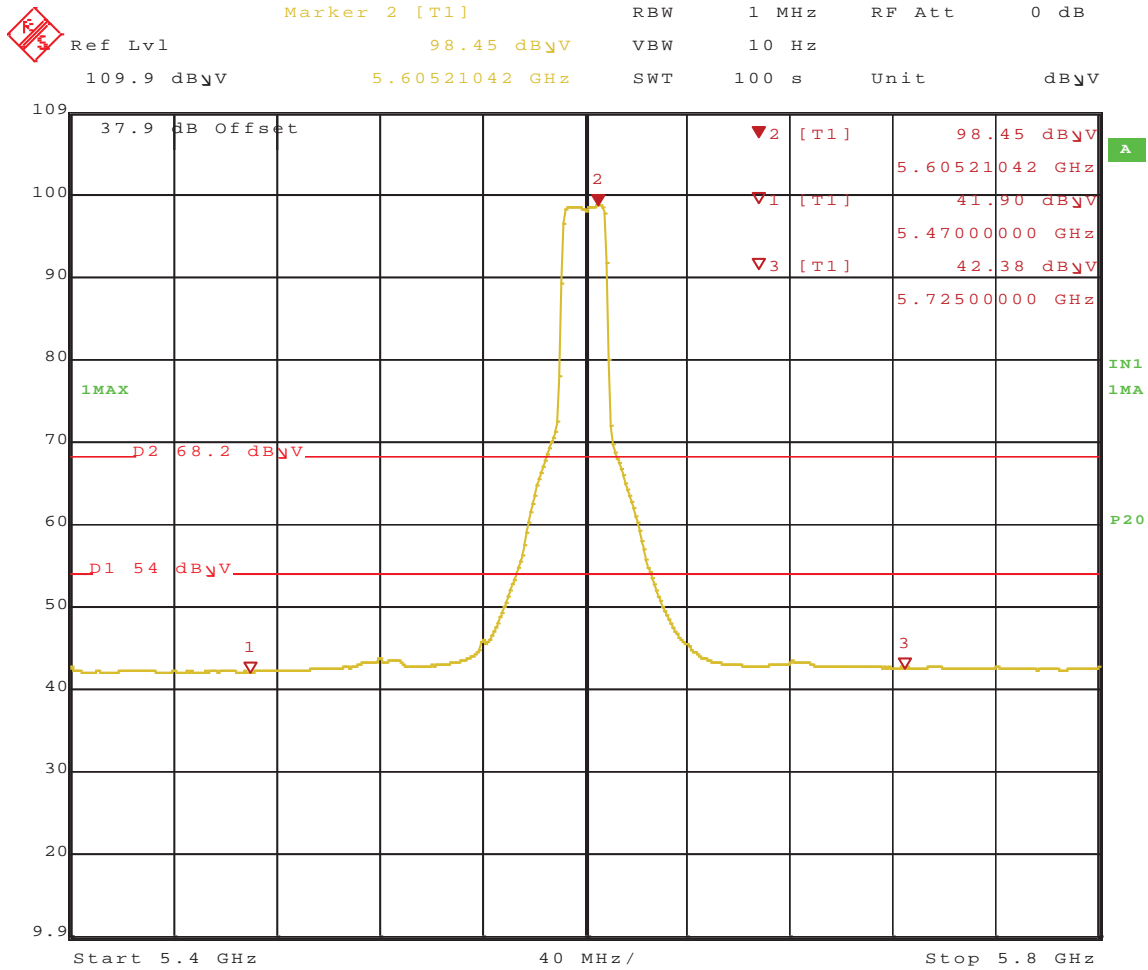

Date: 14.MAR.2011 11:08:00

Figure 572: Radiated Emission at the Edge for 5600 MHz at 6Mbps – Vert. (Ave.)

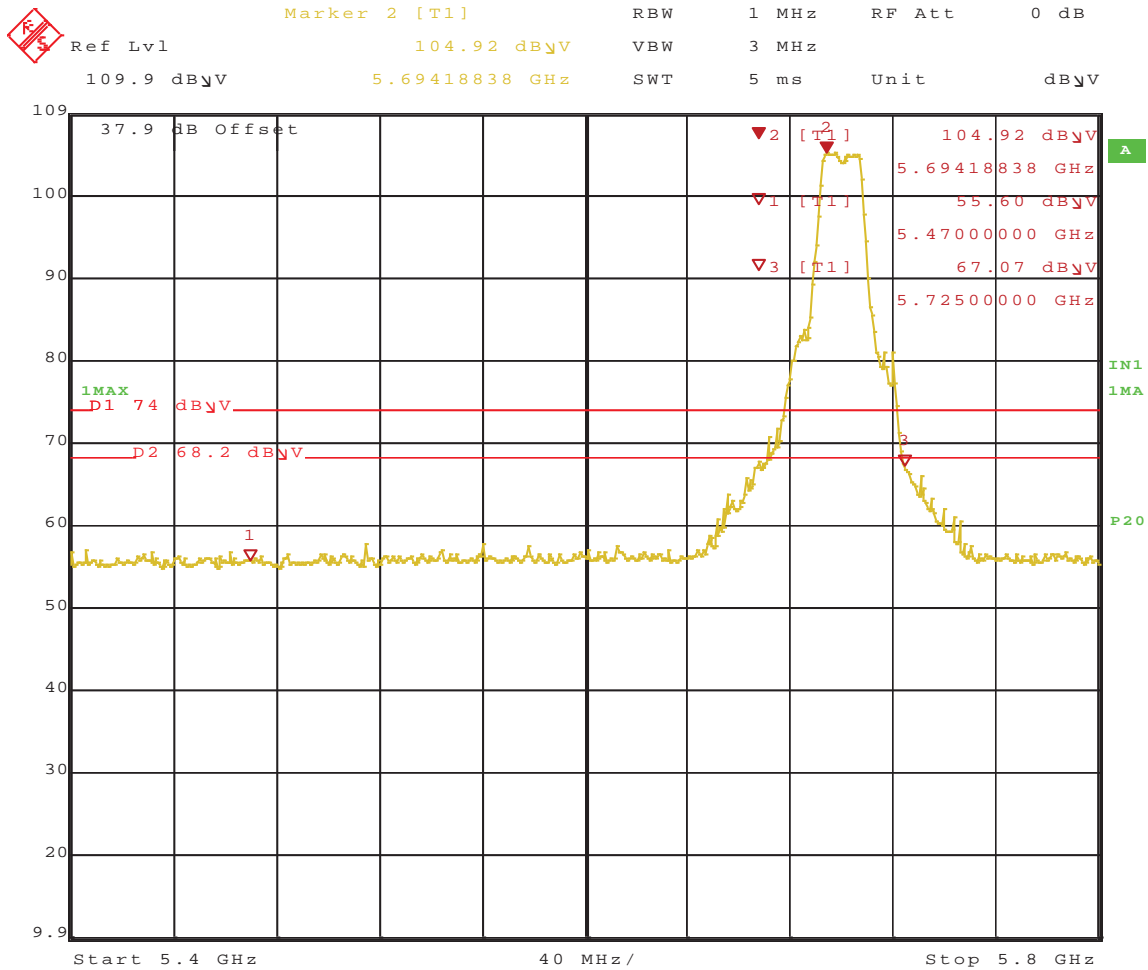

Date: 14.MAR.2011 12:17:27

Figure 573: Radiated Emission at the Edge for 5700 MHz at 6Mbps – Horz. (Peak)

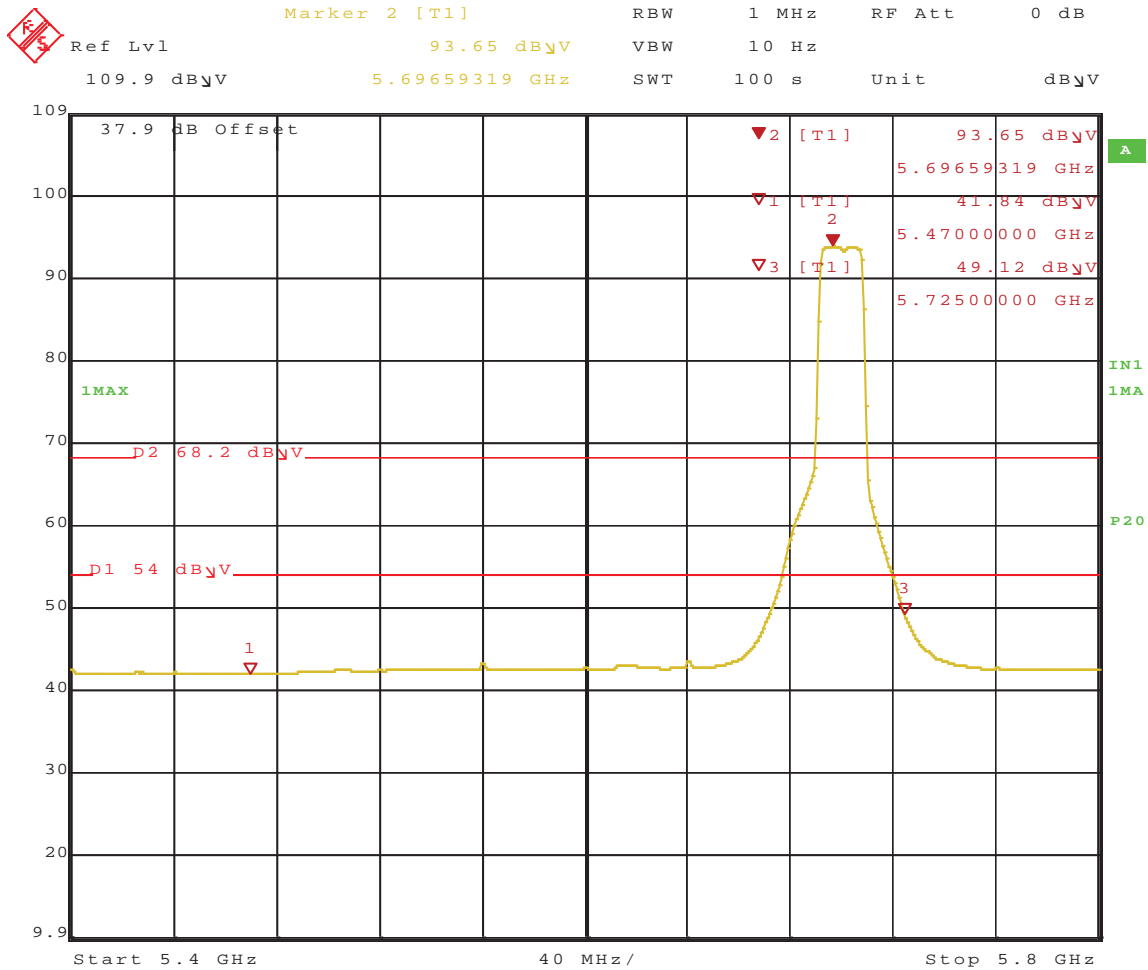

Date: 14.MAR.2011 12:19:21

Figure 574: Radiated Emission at the Edge for 5700 MHz at 6Mbps – Horz. (Ave.)

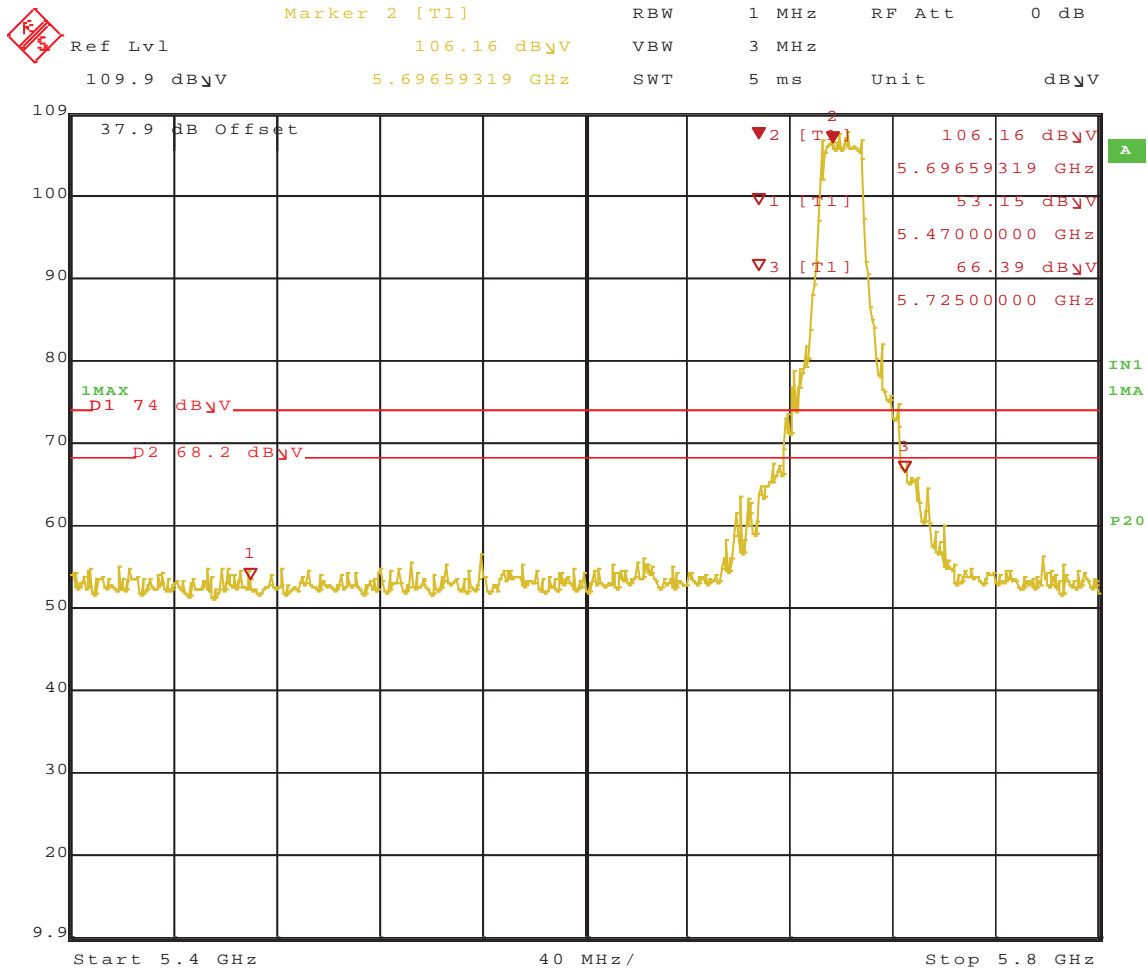

Date: 14.MAR.2011 12:22:27

Figure 575: Radiated Emission at the Edge for 5700 MHz at 6Mbps – Vert. (Peak)

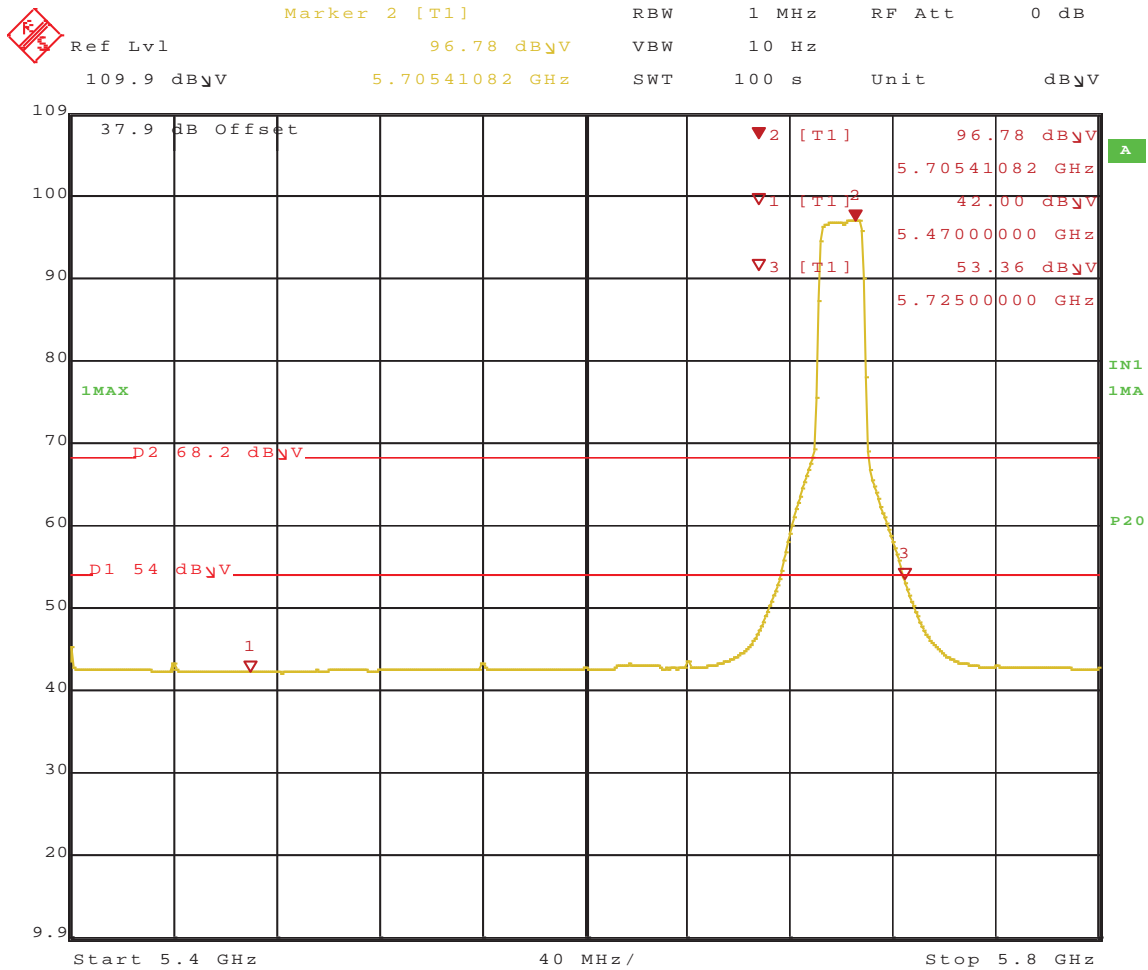
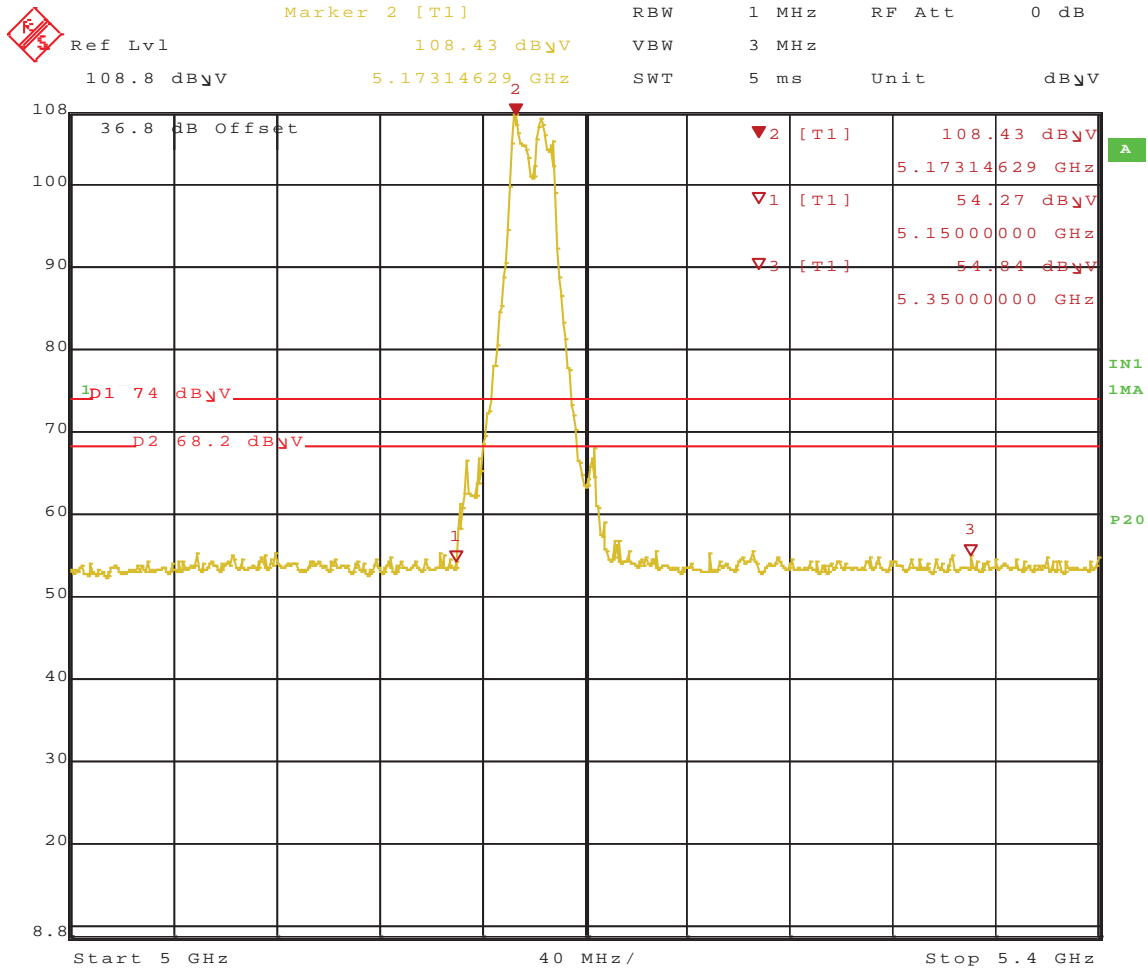
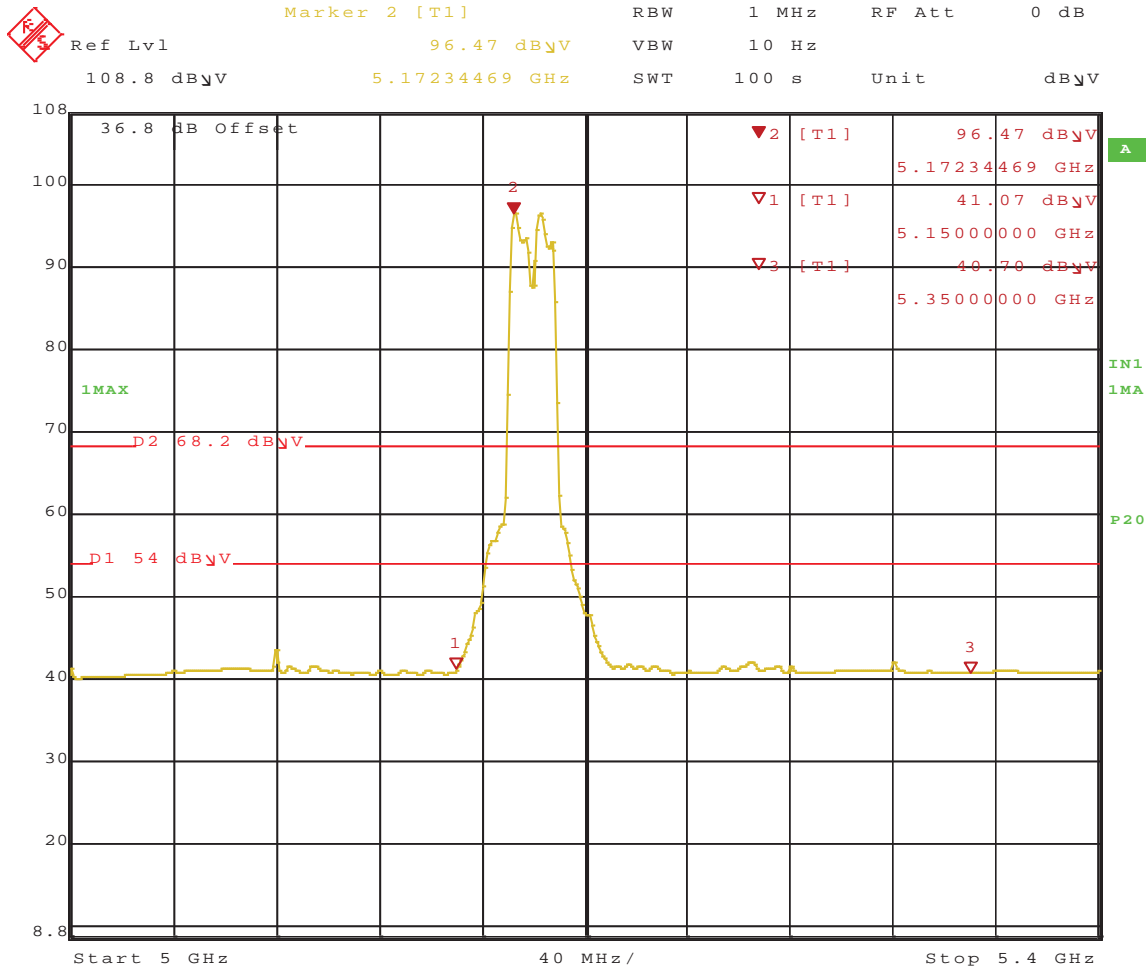

Figure 576: Radiated Emission at the Edge for 5700 MHz at 6Mbps – Vert. (Ave.)



Date: 14.MAR.2011 13:17:56

Figure 577: Radiated Emission at the Edge for Channel 5180 MHz at 19.5Mbps – Horz. (Peak)



Date: 14.MAR.2011 13:17:26

Figure 578: Radiated Emission at the Edge for Channel 5180 MHz at 19.5Mbps – Horz. (Ave.)

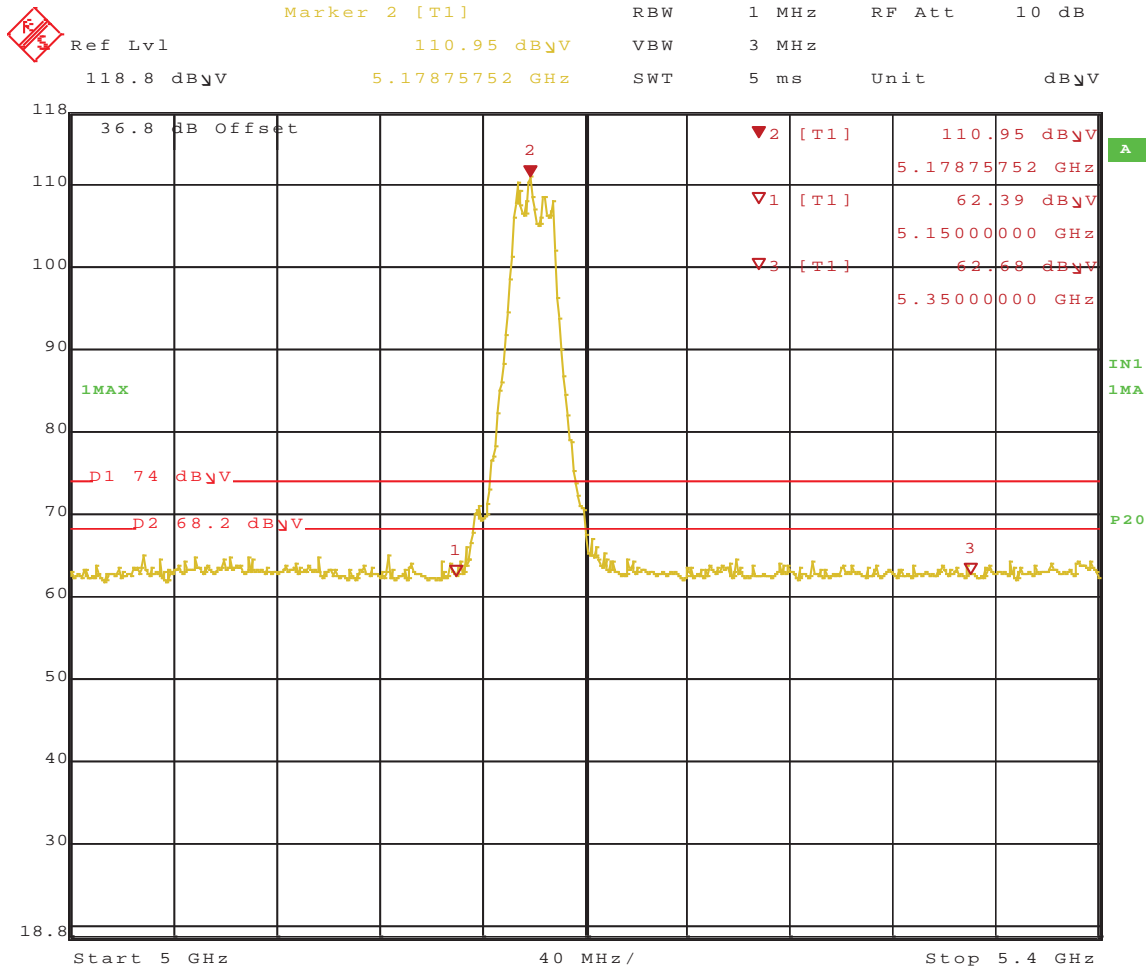

Date: 14.MAR.2011 13:22:01

Figure 579: Radiated Emission at the Edge for Channel 5180 MHz at 19.5Mbps – Vert. (Peak)

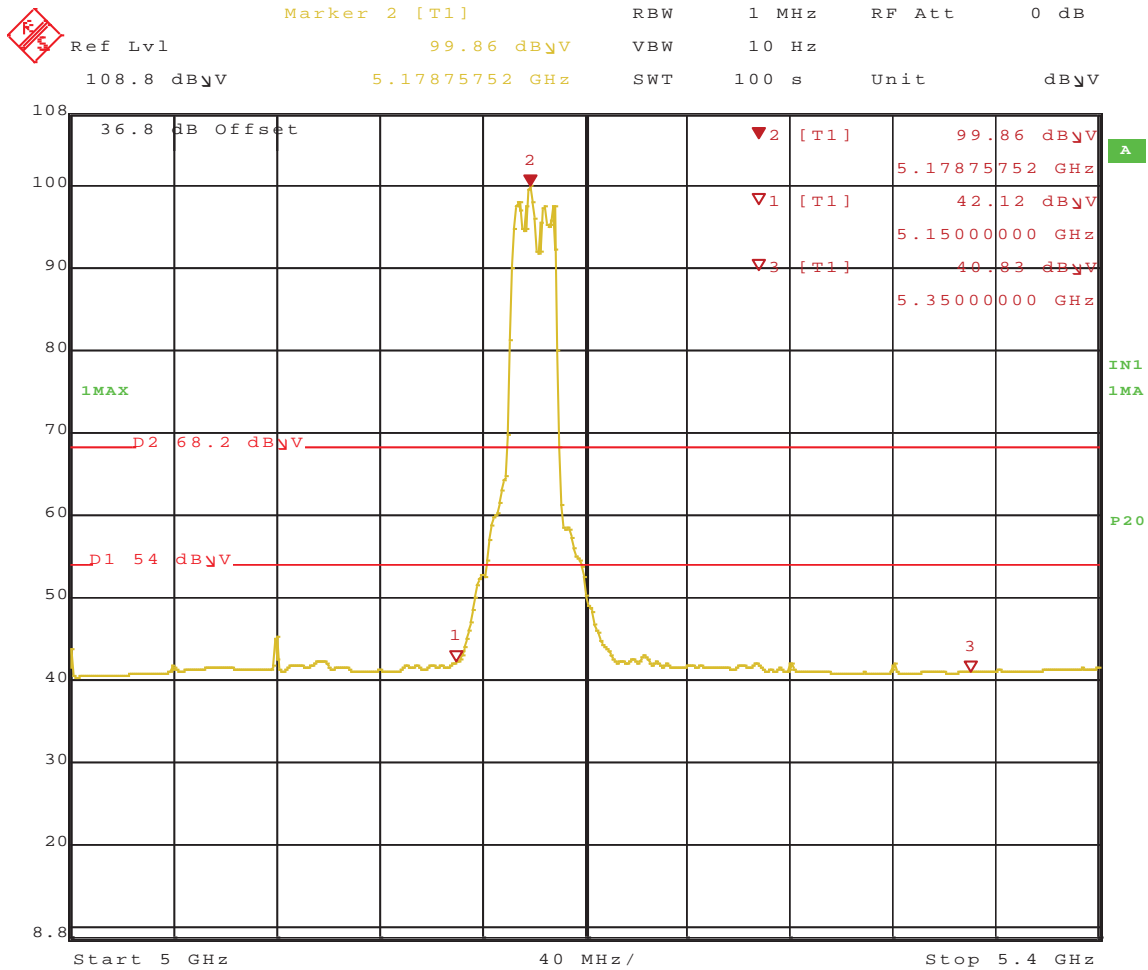

Date: 14.MAR.2011 13:24:18

Figure 580: Radiated Emission at the Edge for Channel 5180 MHz at 19.5Mbps – Vert. (Ave.)

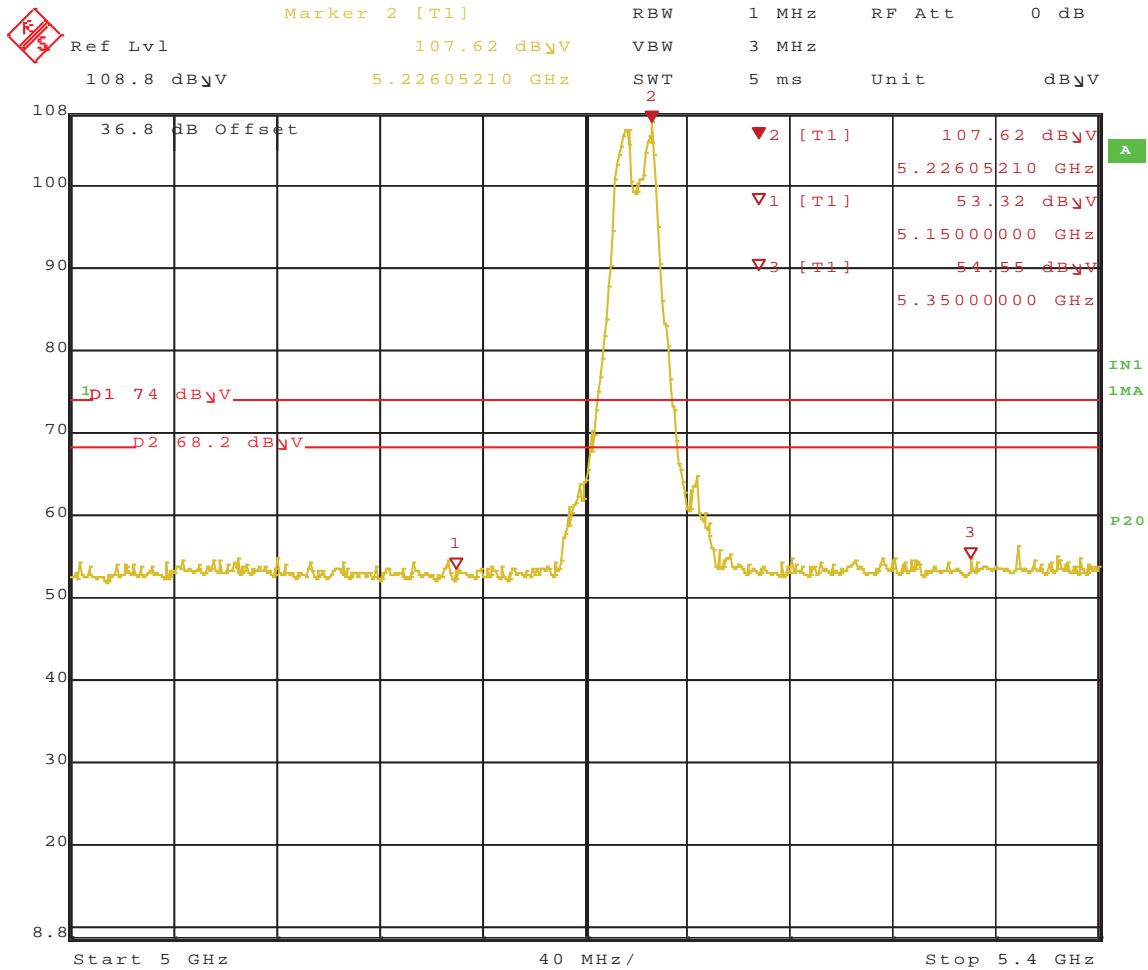

Date: 14.MAR.2011 13:32:30

Figure 581: Radiated Emission at the Edge for Channel 5220 MHz at 19.5Mbps – Horz. (Peak)

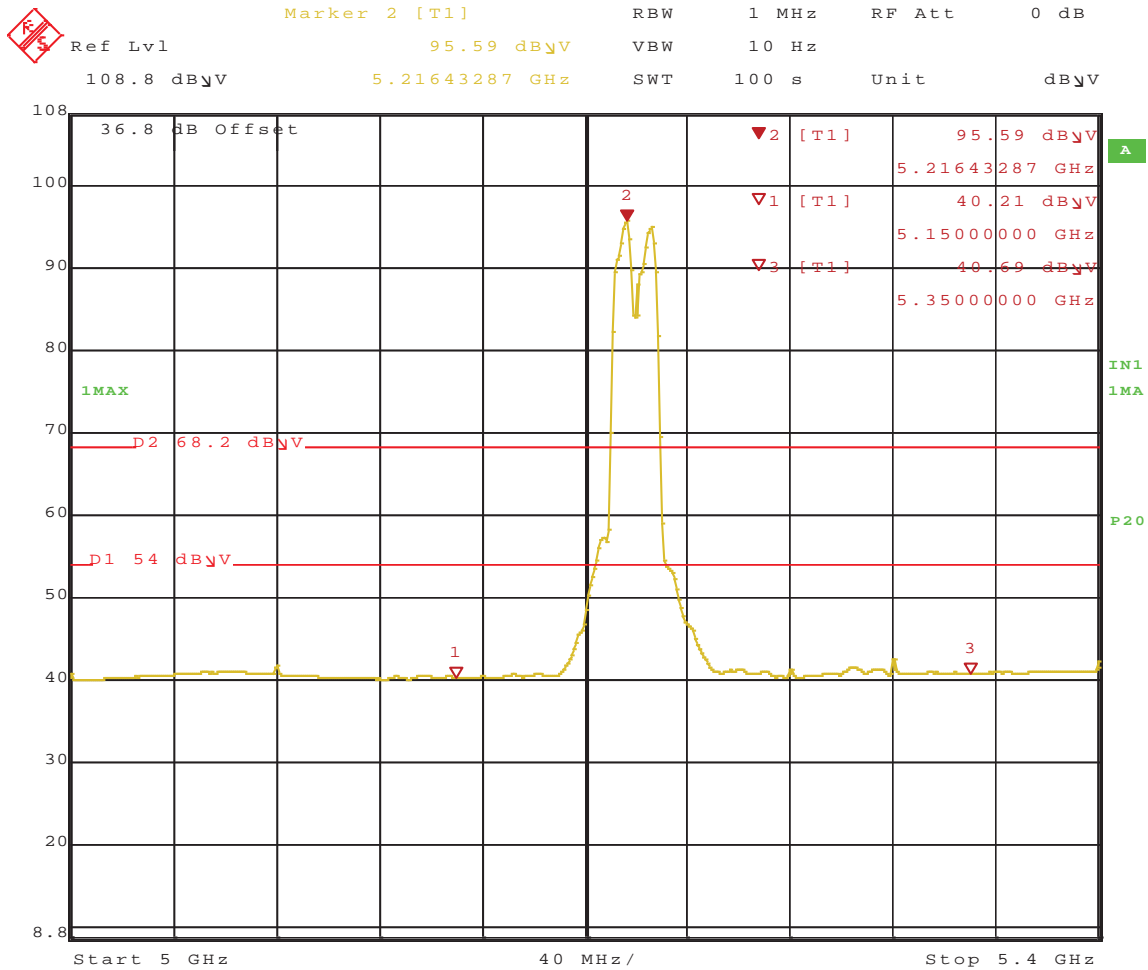

Date: 14.MAR.2011 13:34:41

Figure 582: Radiated Emission at the Edge for Channel 5220 MHz at 19.5Mbps – Horz. (Ave.)

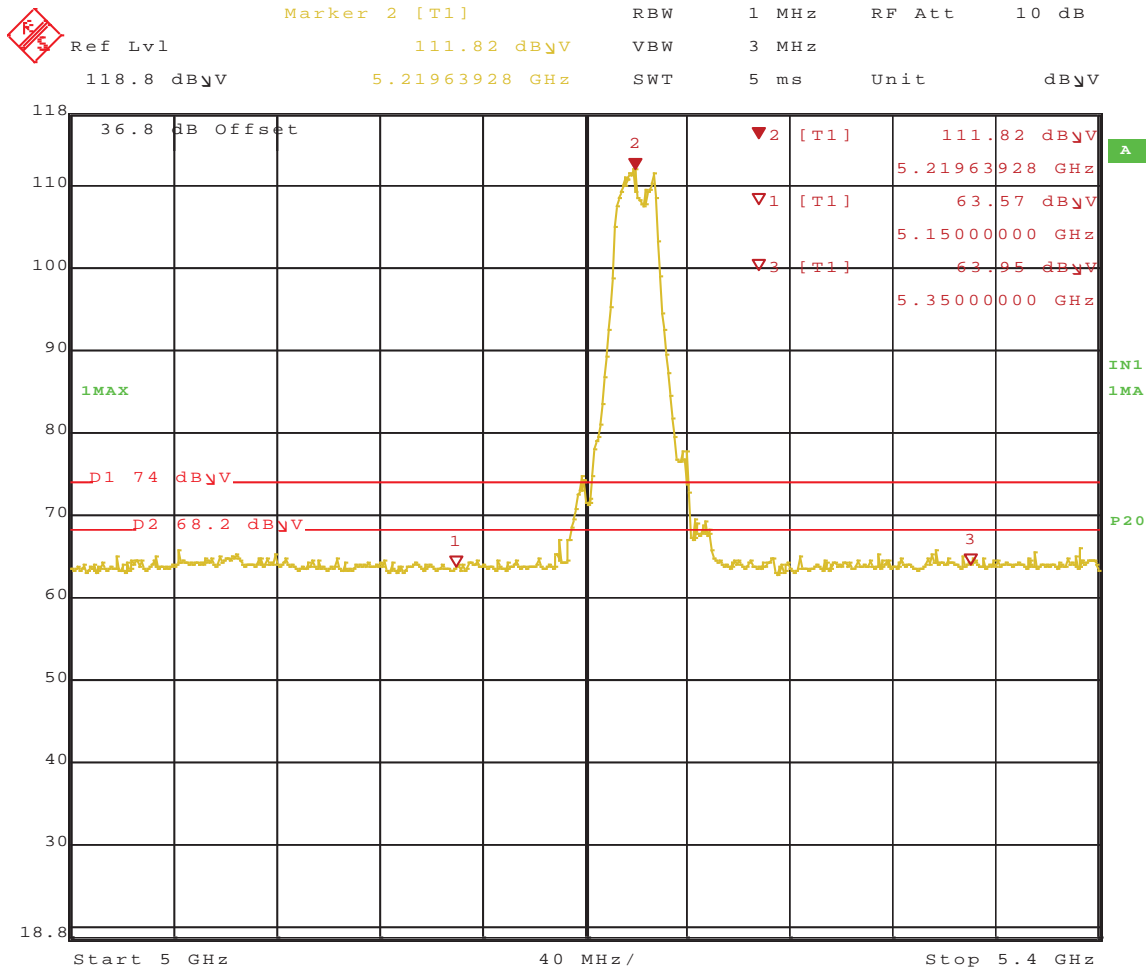

Date: 14.MAR.2011 13:27:55

Figure 583: Radiated Emission at the Edge for Channel 5220 MHz at 19.5Mbps – Vert. (Peak)

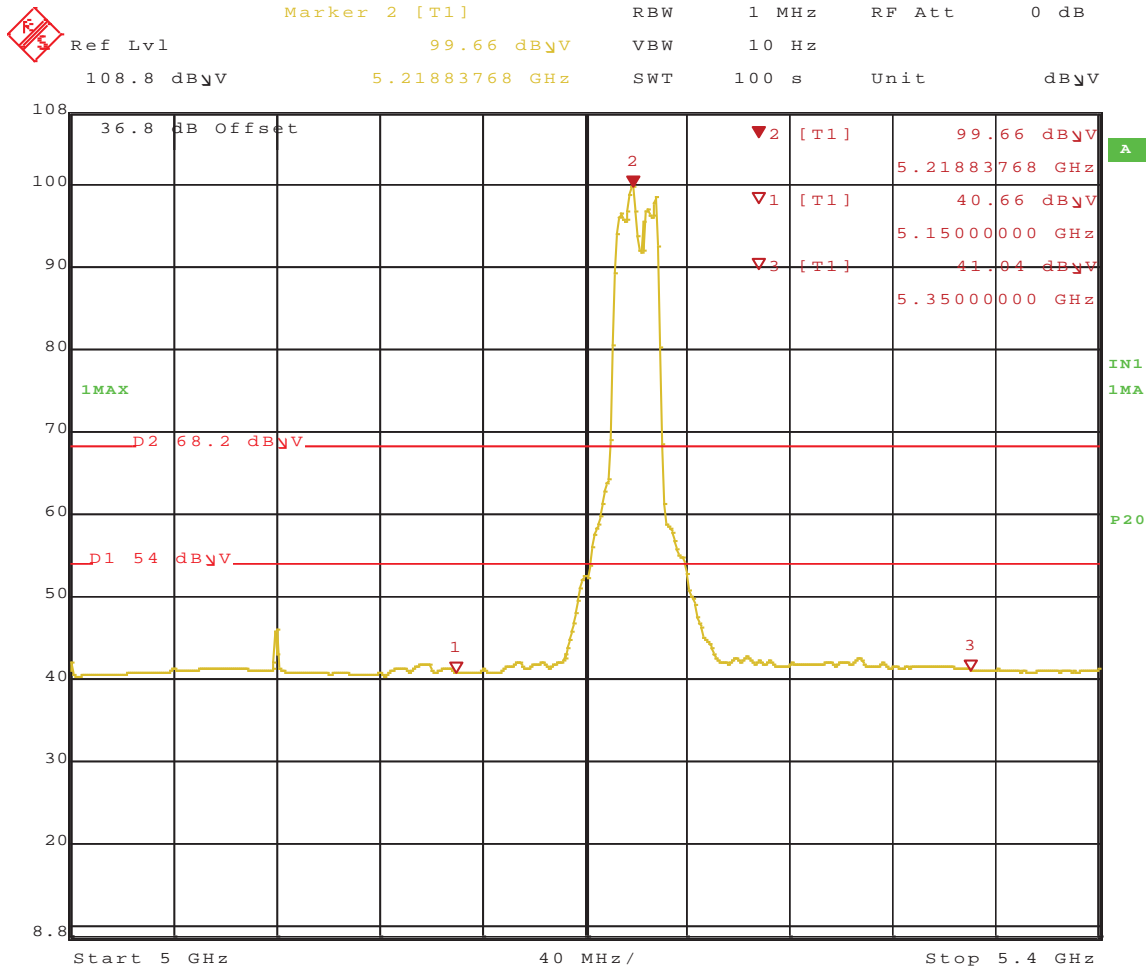

Date: 14.MAR.2011 13:30:05

Figure 584: Radiated Emission at the Edge for Channel 5220 MHz at 19.5Mbps – Vert. (Ave.)

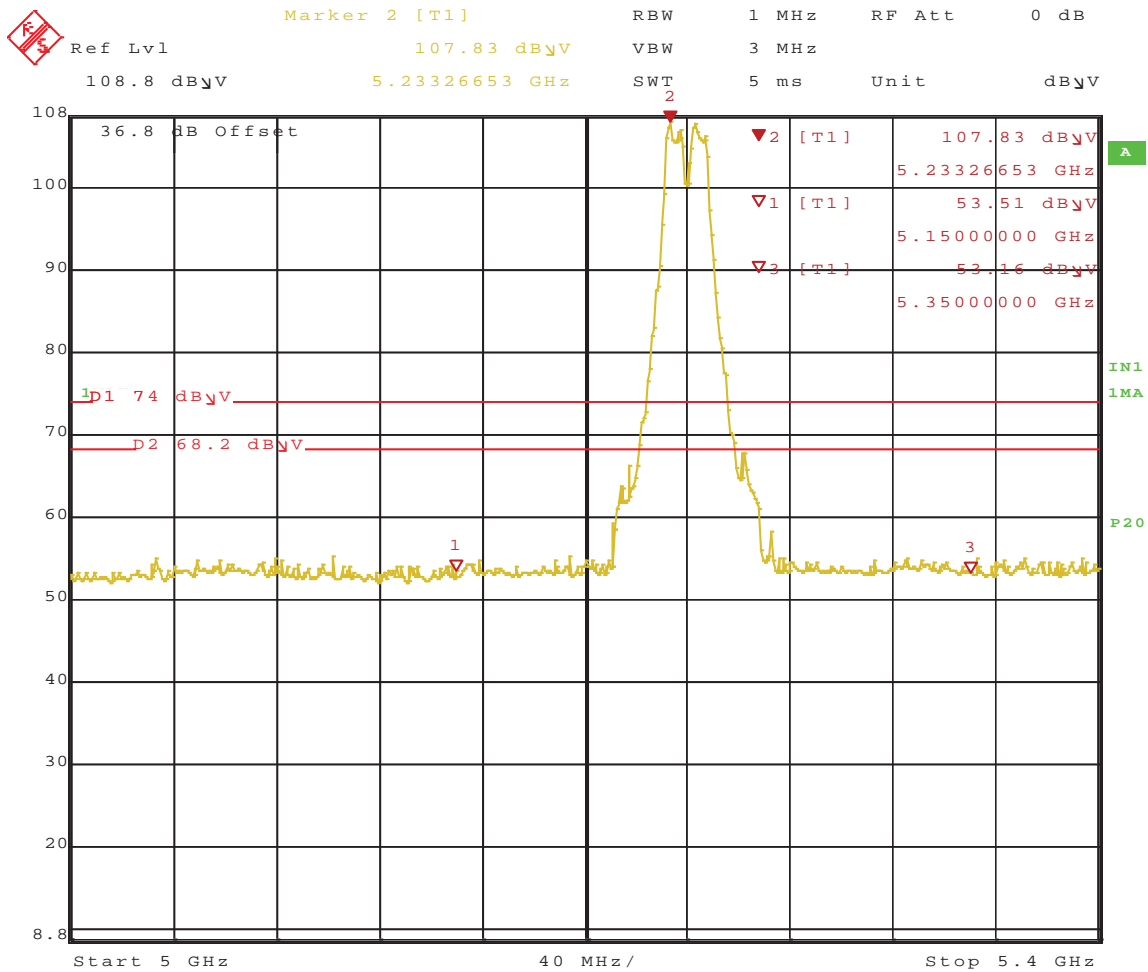

Date: 14.MAR.2011 13:37:21

Figure 585: Radiated Emission at the Edge for Channel 5240 MHz at 19.5Mbps – Horz. (Peak)

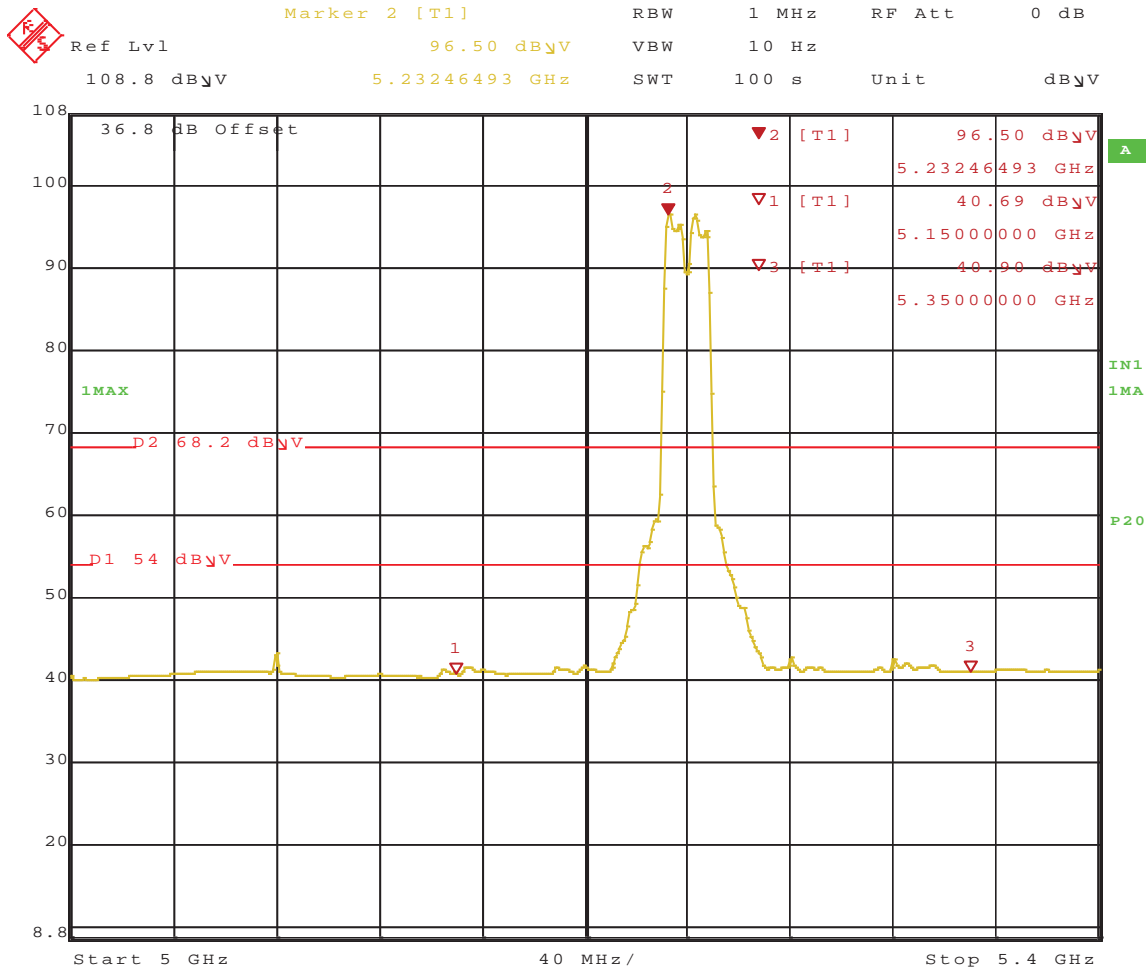
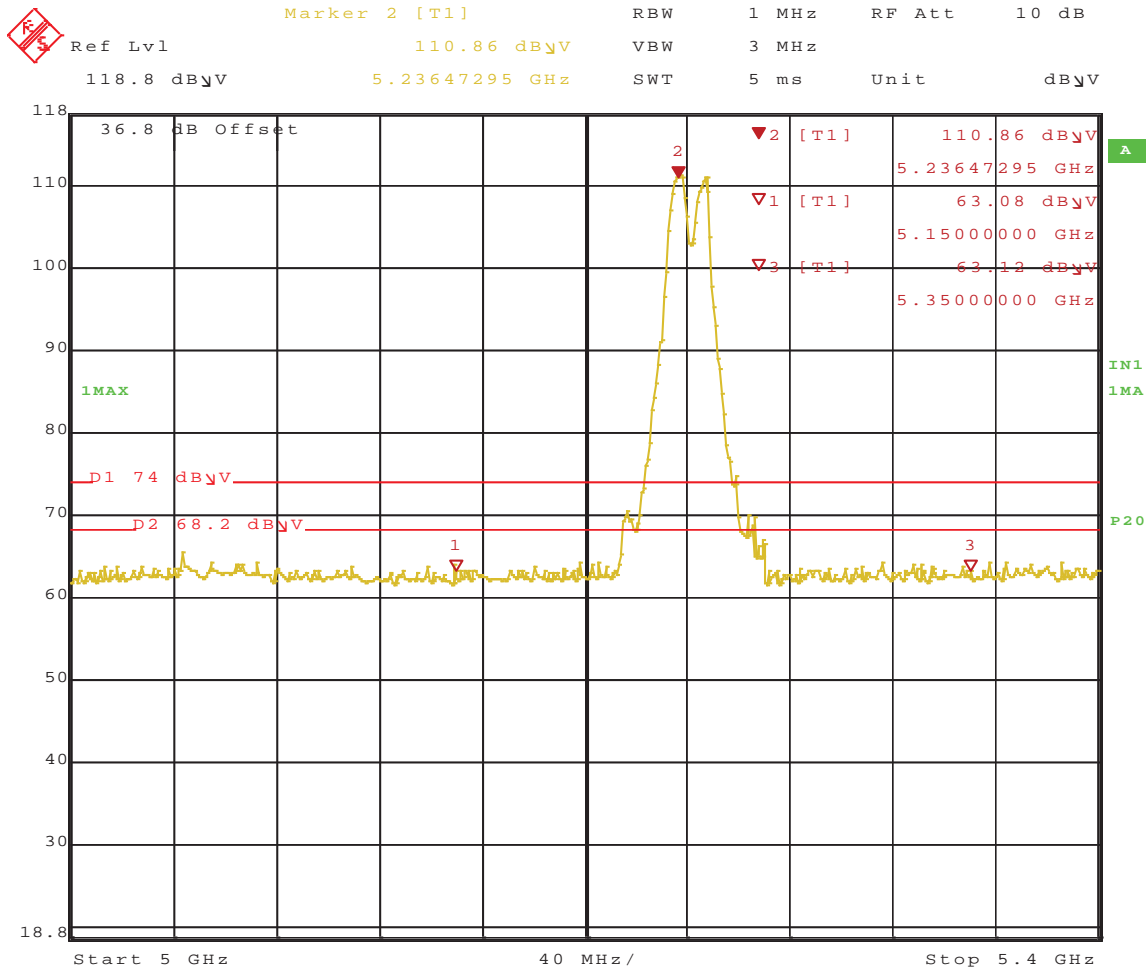
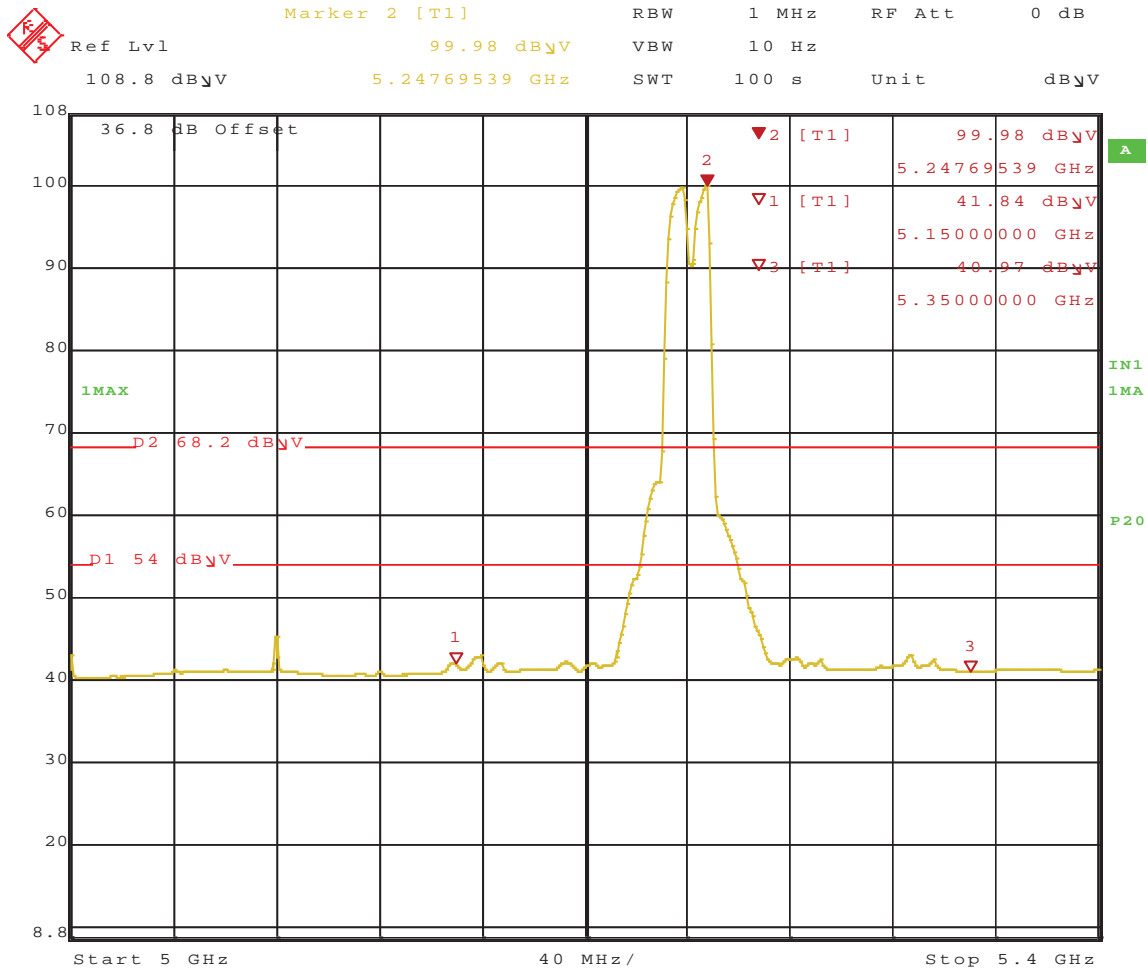

Figure 586: Radiated Emission at the Edge for Channel 5240 MHz at 19.5Mbps – Horz. (Ave.)



Date: 14.MAR.2011 13:42:13

Figure 587: Radiated Emission at the Edge for Channel 5240 MHz at 19.5Mbps – Vert. (Peak)



Date: 14.MAR.2011 13:44:16

Figure 588: Radiated Emission at the Edge for Channel 5240 MHz at 19.5Mbps – Vert. (Ave.)

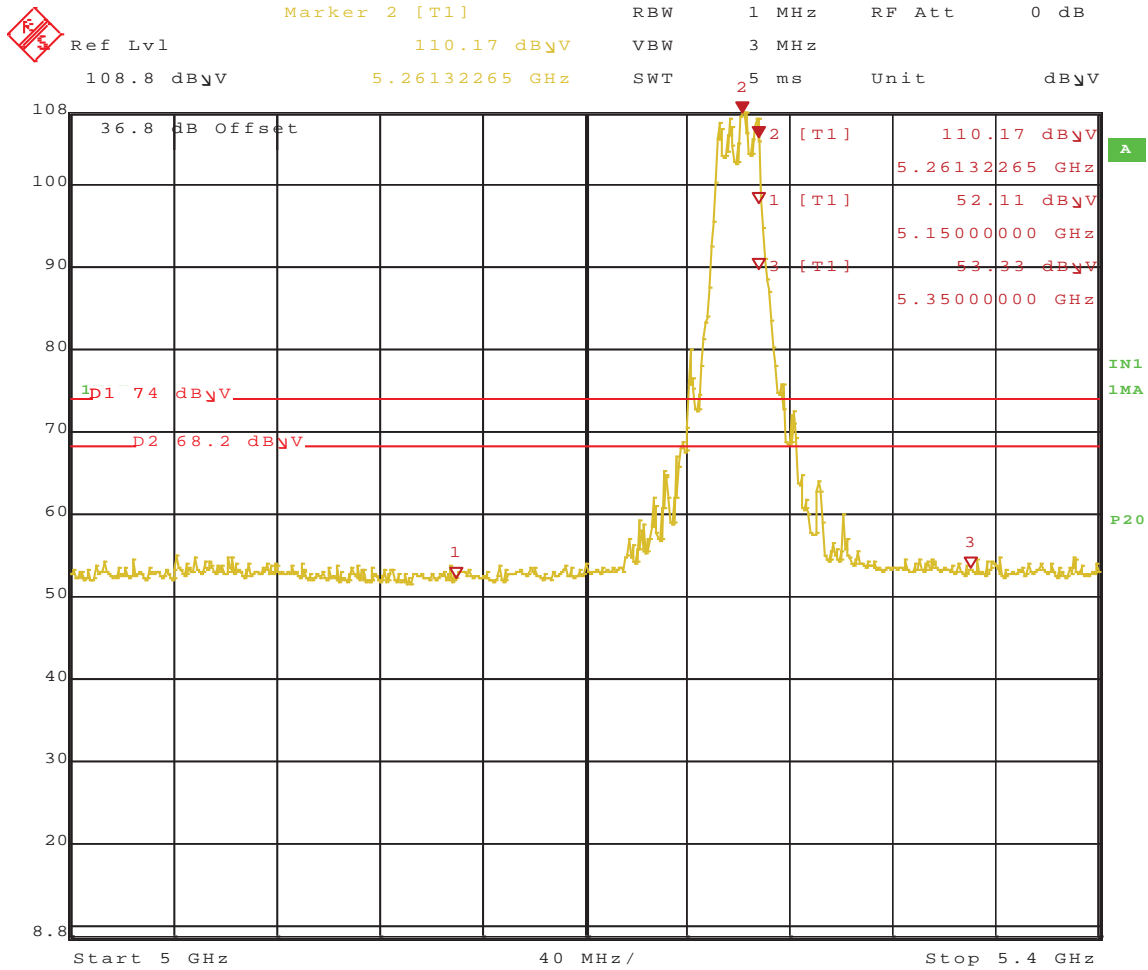

Date: 14.MAR.2011 13:51:14

Figure 589: Radiated Emission at the Edge for Channel 5260 MHz at 19.5Mbps – Horz (Peak)

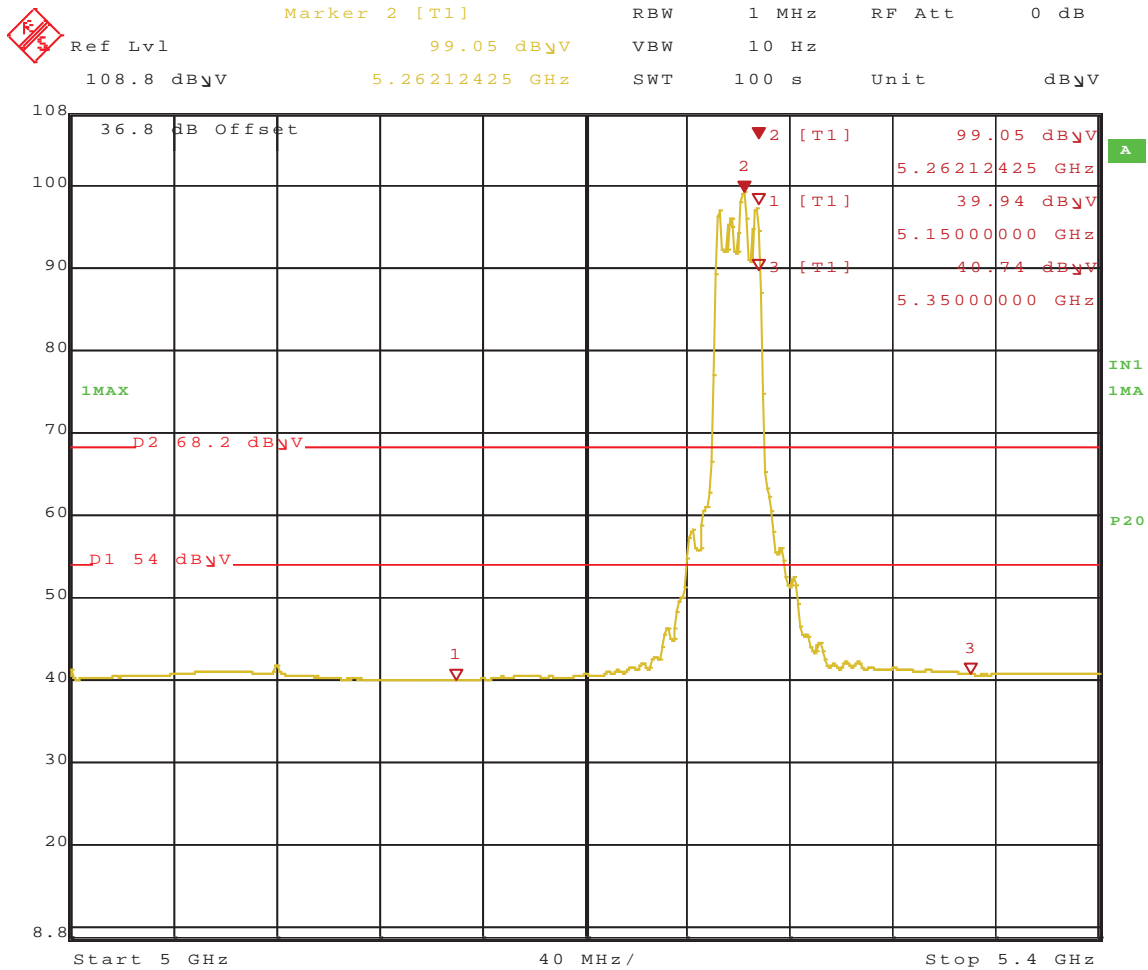

Date: 14.MAR.2011 13:53:17

Figure 590: Radiated Emission at the Edge for Channel 5260 MHz at 19.5Mbps – Horz (Ave.)

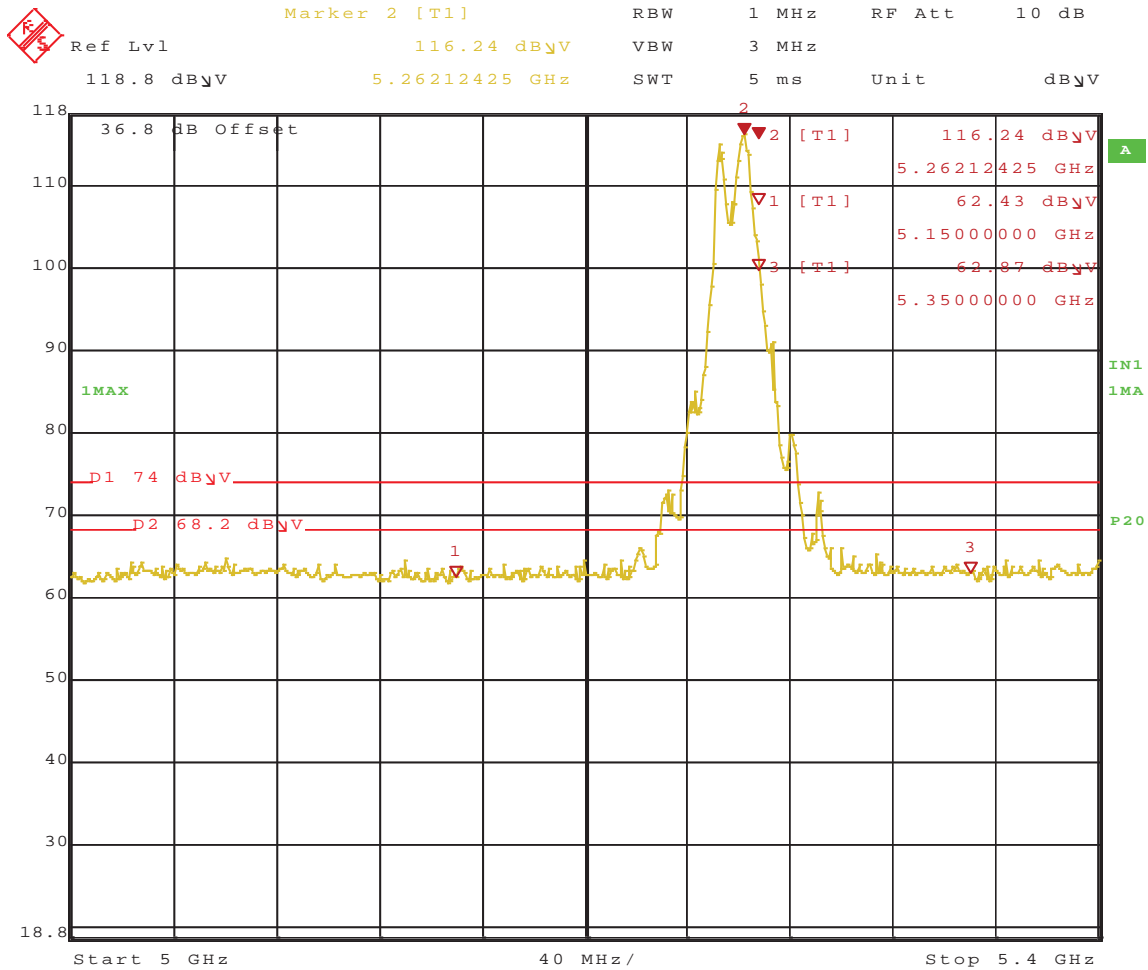

Date: 14.MAR.2011 13:46:33

Figure 591: Radiated Emission at the Edge for Channel 5260 MHz at 19.5Mbps – Vert (Peak)

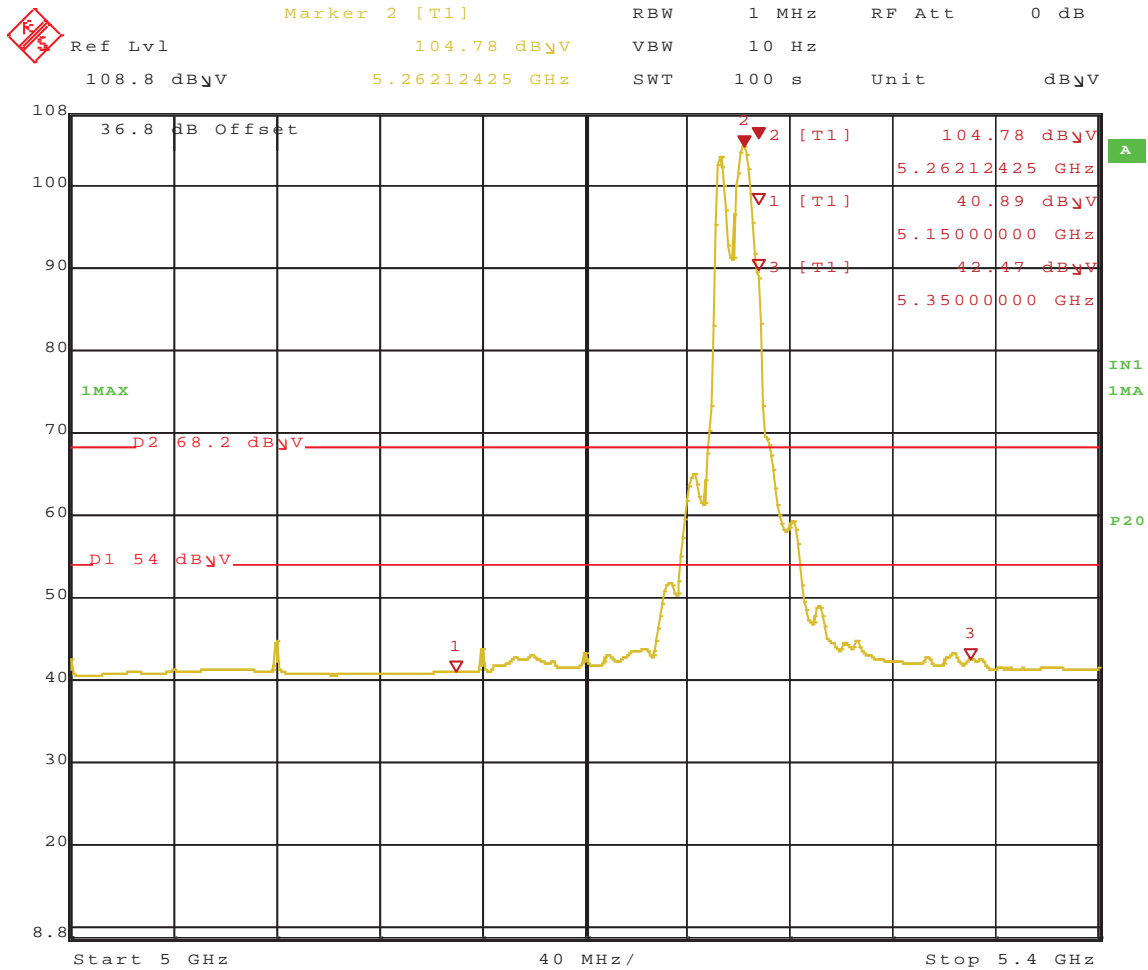

Date: 14.MAR.2011 13:48:51

Figure 592: Radiated Emission at the Edge for Channel 5260 MHz at 19.5Mbps – Vert (Ave.)

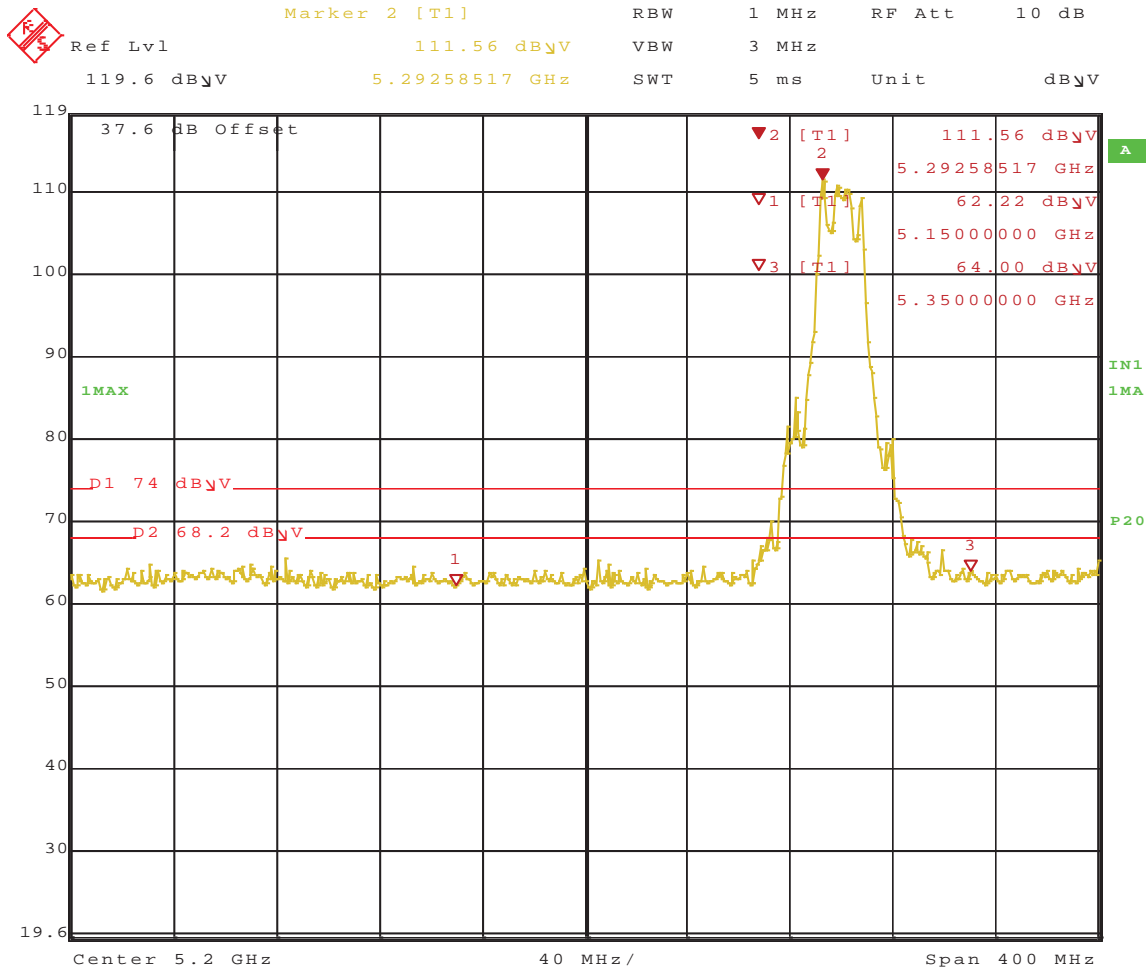

Date: 14.MAR.2011 13:56:24

Figure 593: Radiated Emission at the Edge for Channel 5300 MHz at 19.5Mbps – Horz. (Peak)

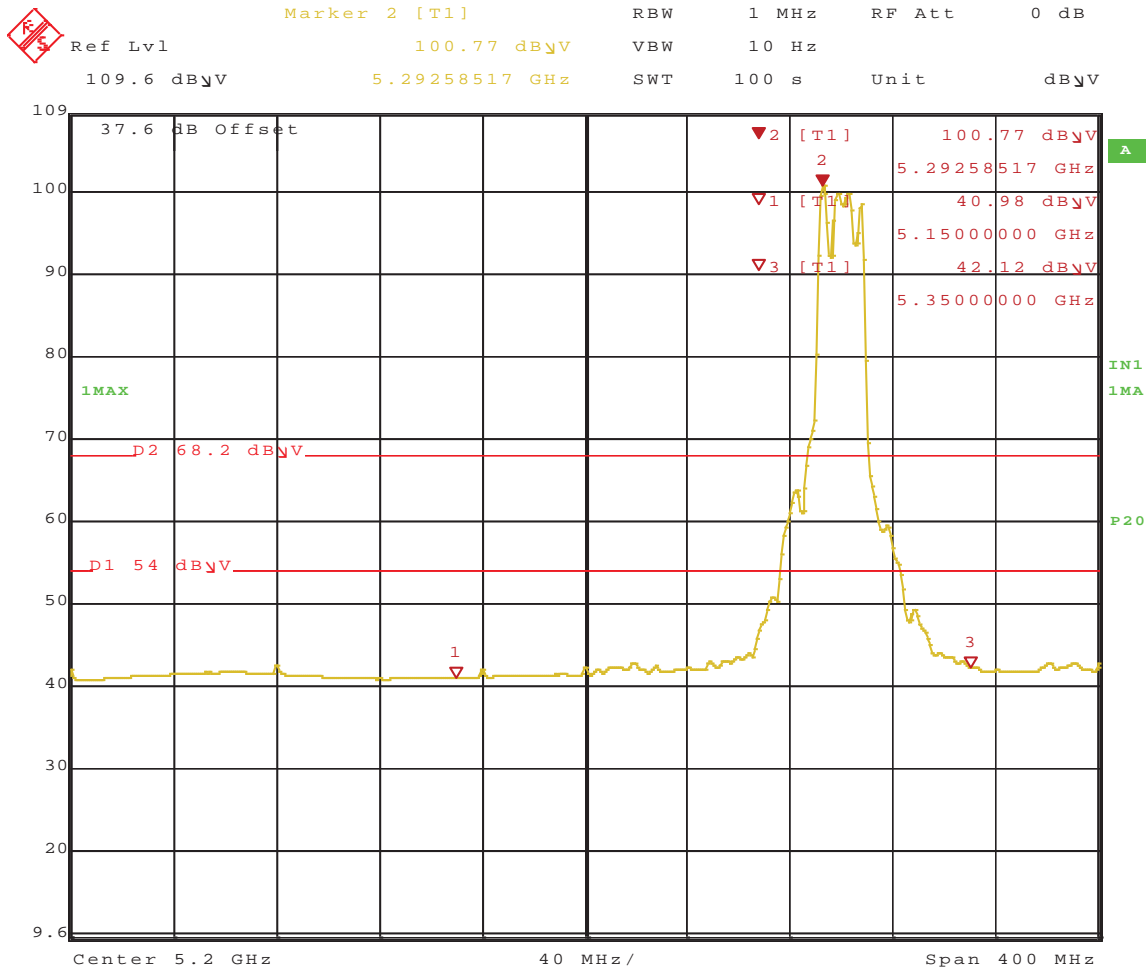

Date: 14.MAR.2011 13:58:33

Figure 594: Radiated Emission at the Edge for Channel 5300 MHz at 19.5Mbps – Horz. (Ave.)

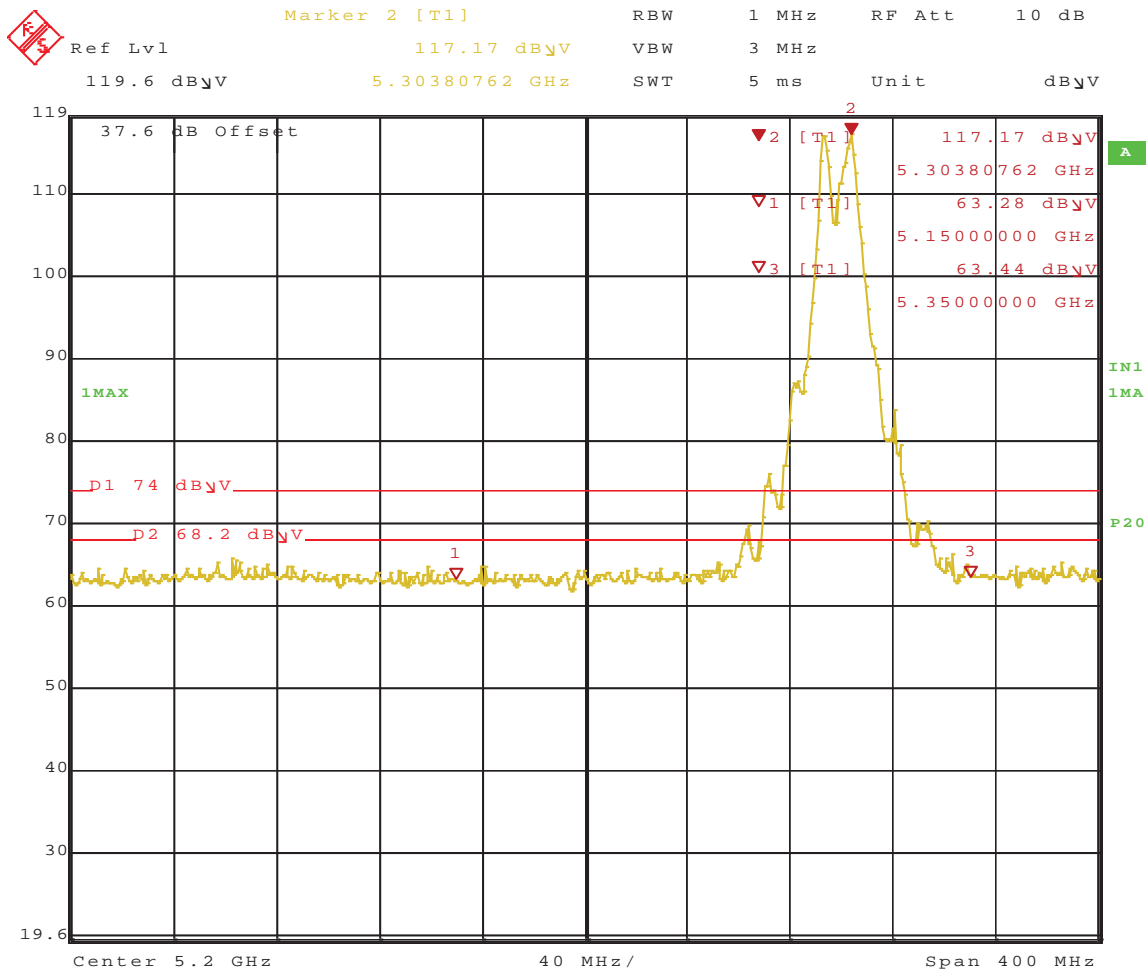

Date: 14.MAR.2011 14:01:00

Figure 595: Radiated Emission at the Edge for Channel 5300 MHz at 19.5Mbps – Vert. (Peak)

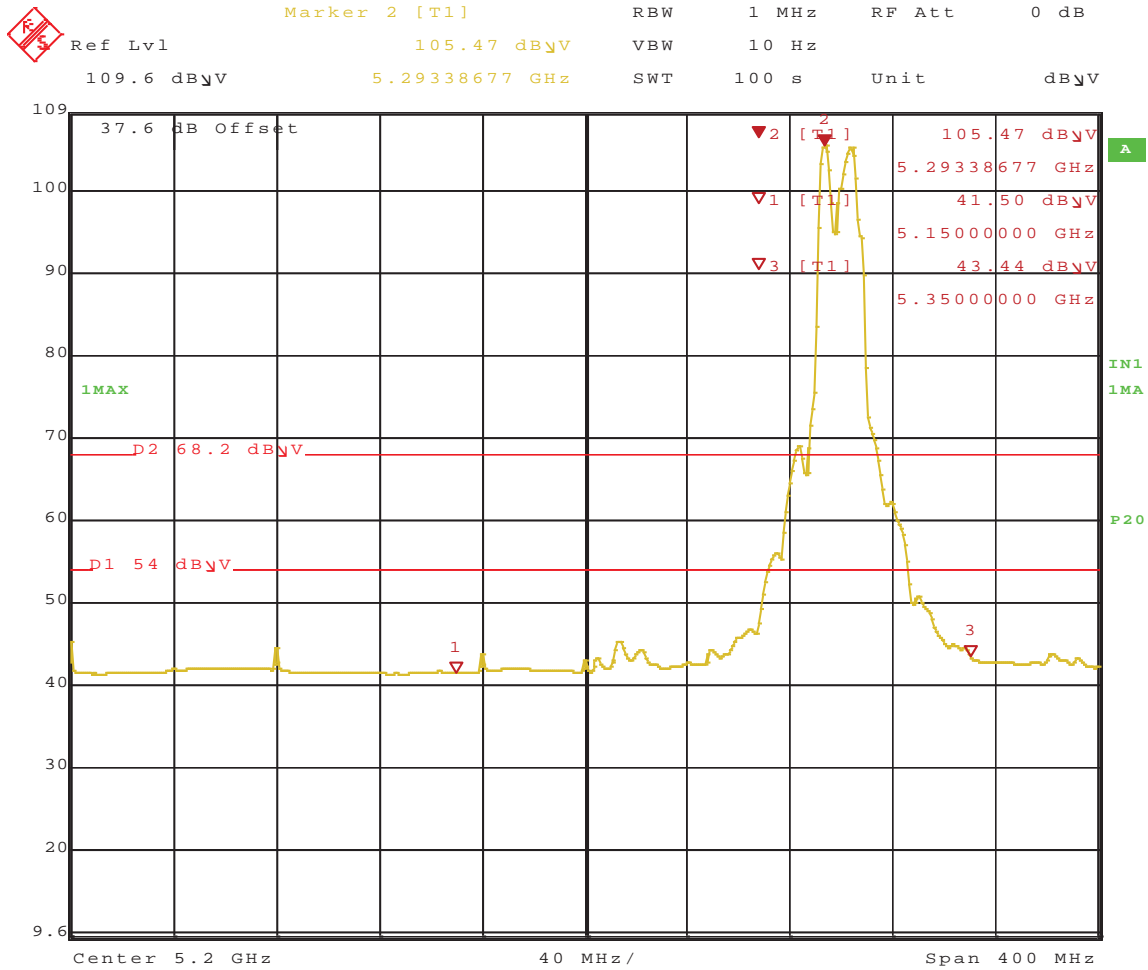

Date: 14.MAR.2011 14:03:21

Figure 596: Radiated Emission at the Edge for Channel 5300 MHz at 19.5Mbps – Vert. (Ave.)

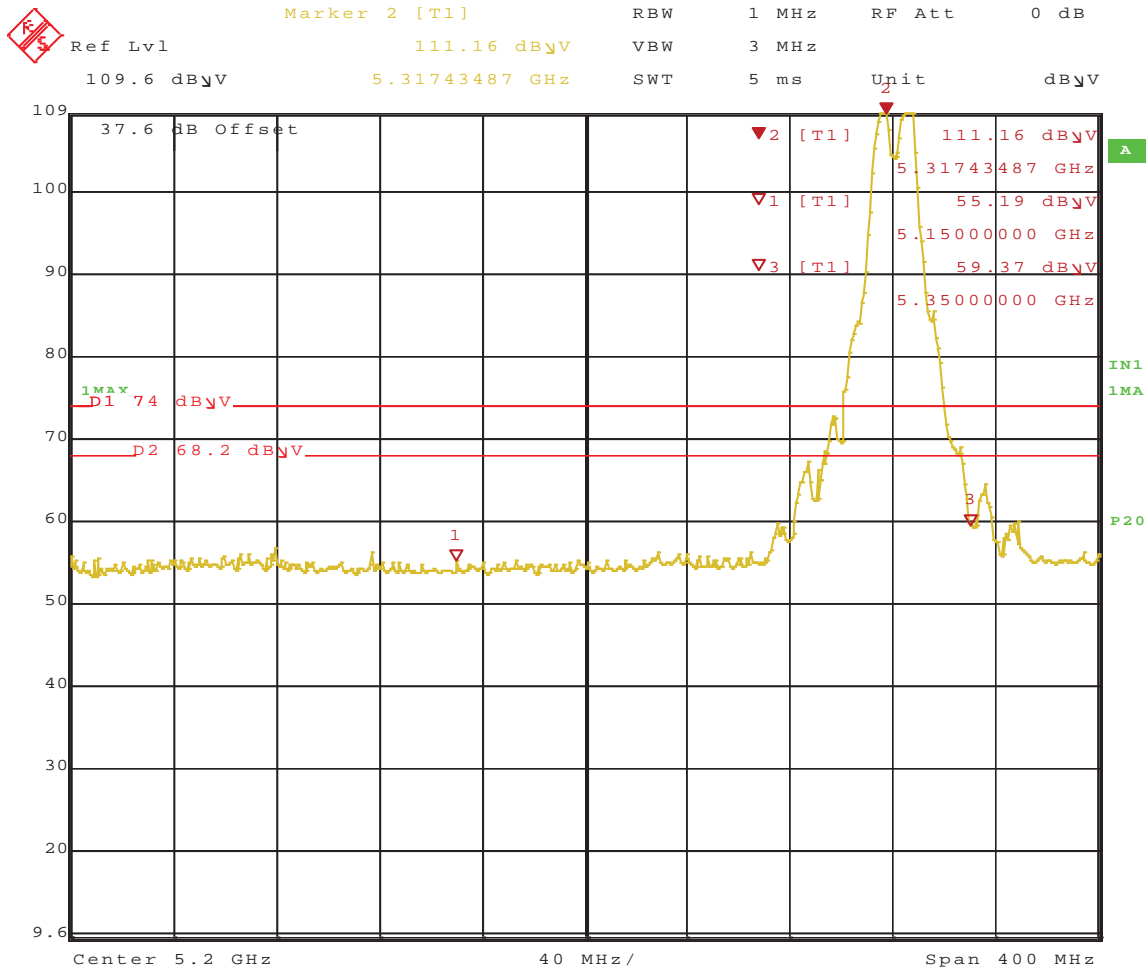

Date: 14.MAR.2011 14:12:54

Figure 597: Radiated Emission at the Edge for Channel 5320 MHz at 19.5Mbps – Horz. (Peak)

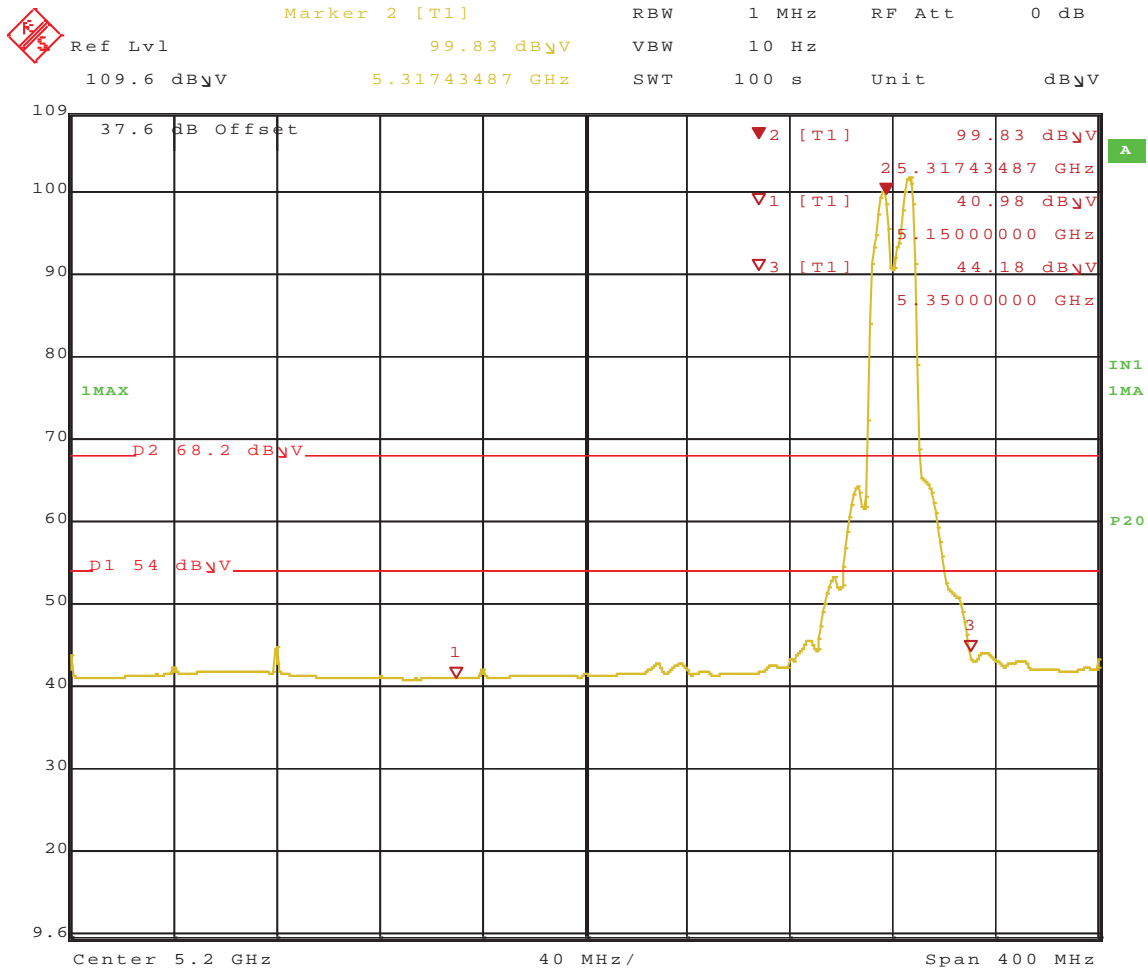

Date: 14.MAR.2011 14:17:07

Figure 598: Radiated Emission at the Edge for Channel 5320 MHz at 19.5Mbps – Horz. (Ave.)

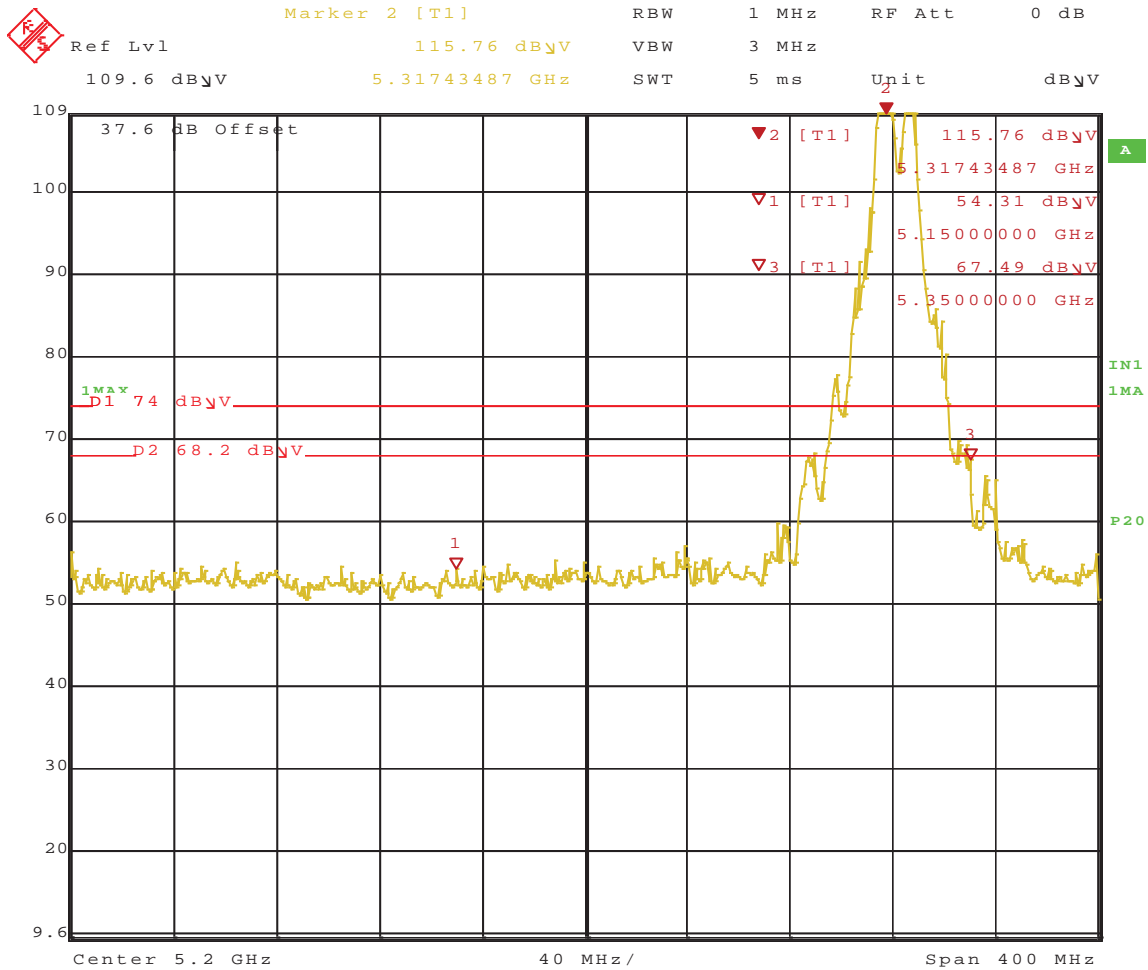

Date: 14.MAR.2011 14:07:35

Figure 599: Radiated Emission at the Edge for Channel 5320 MHz at 19.5Mbps – Vert. (Peak)

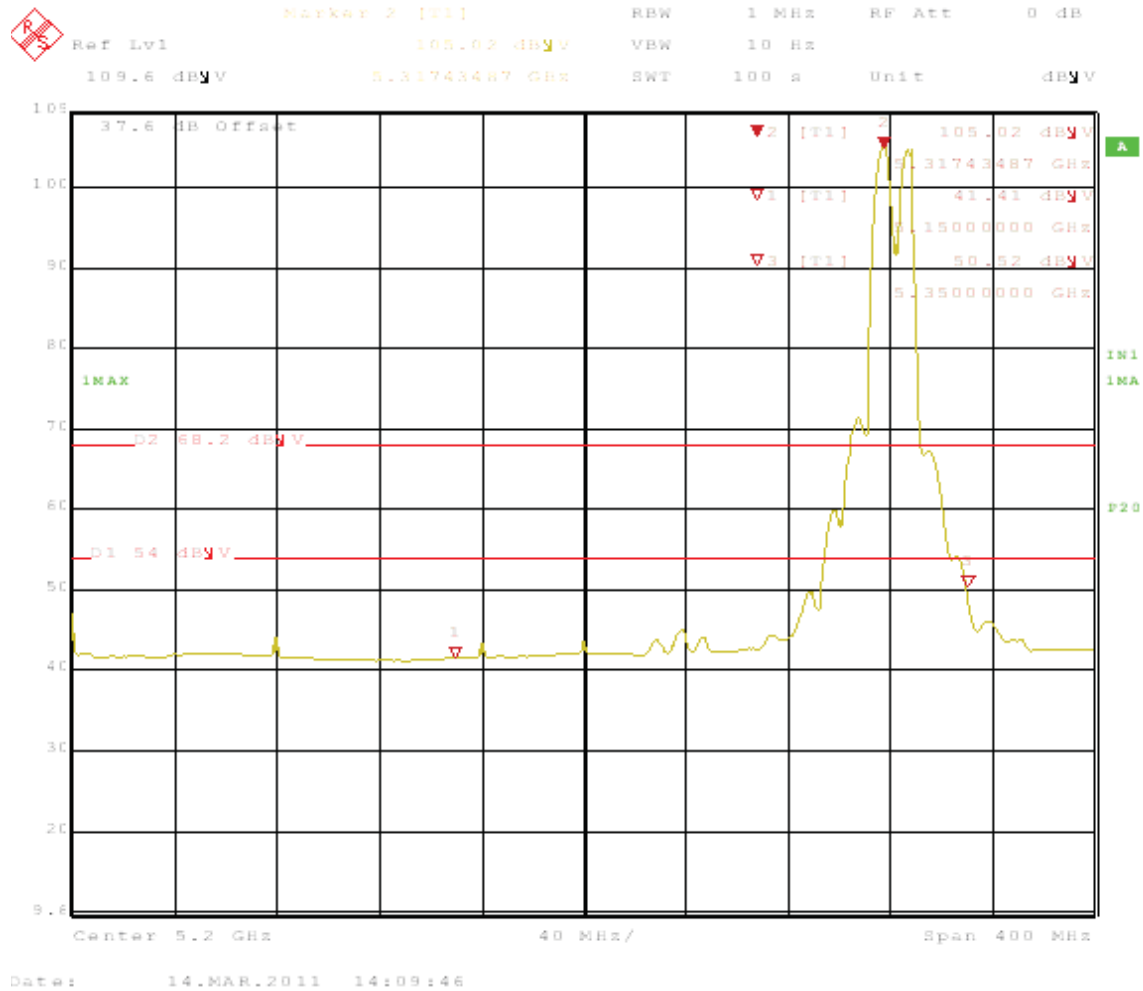
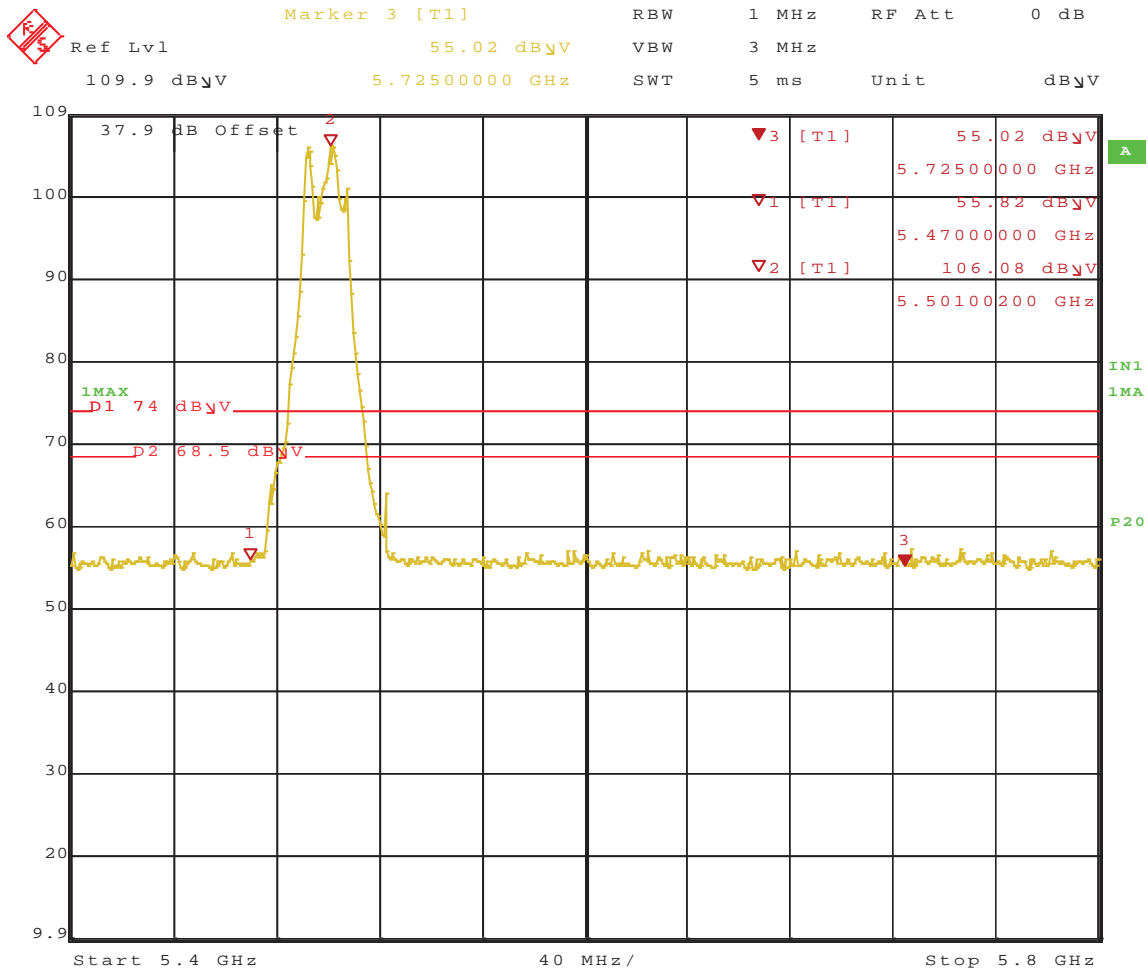
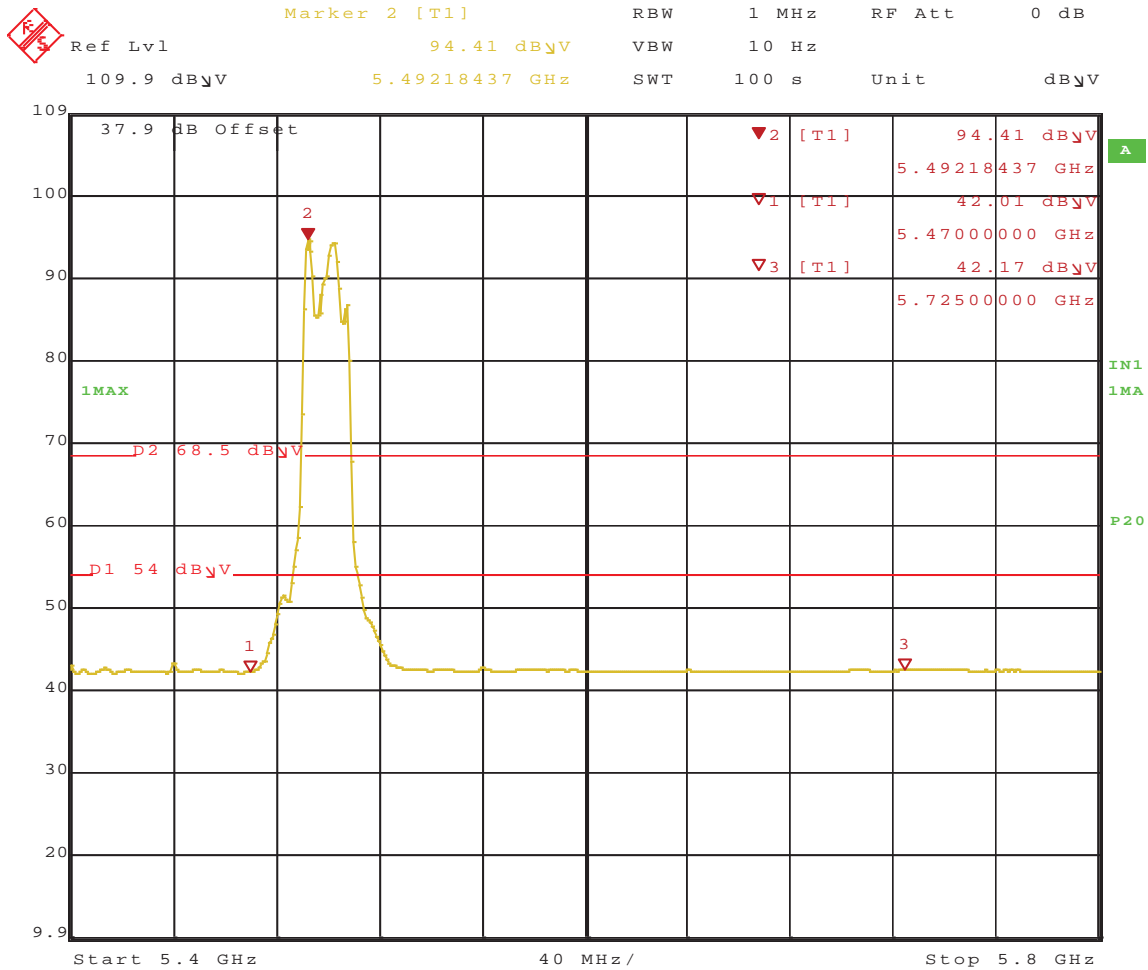

Figure 600: Radiated Emission at the Edge for Channel 5320 MHz at 19.5Mbps – Vert. (Ave.)



Date: 14.MAR.2011 14:19:59

Figure 601: Radiated Emission at the Edge for 5500 MHz at 19.5Mbps – Horiz. (Peak)



Date: 14.MAR.2011 14:22:03

Figure 602: Radiated Emission at the Edge for 5500 MHz at 19.5Mbps – Horz. (Ave.)

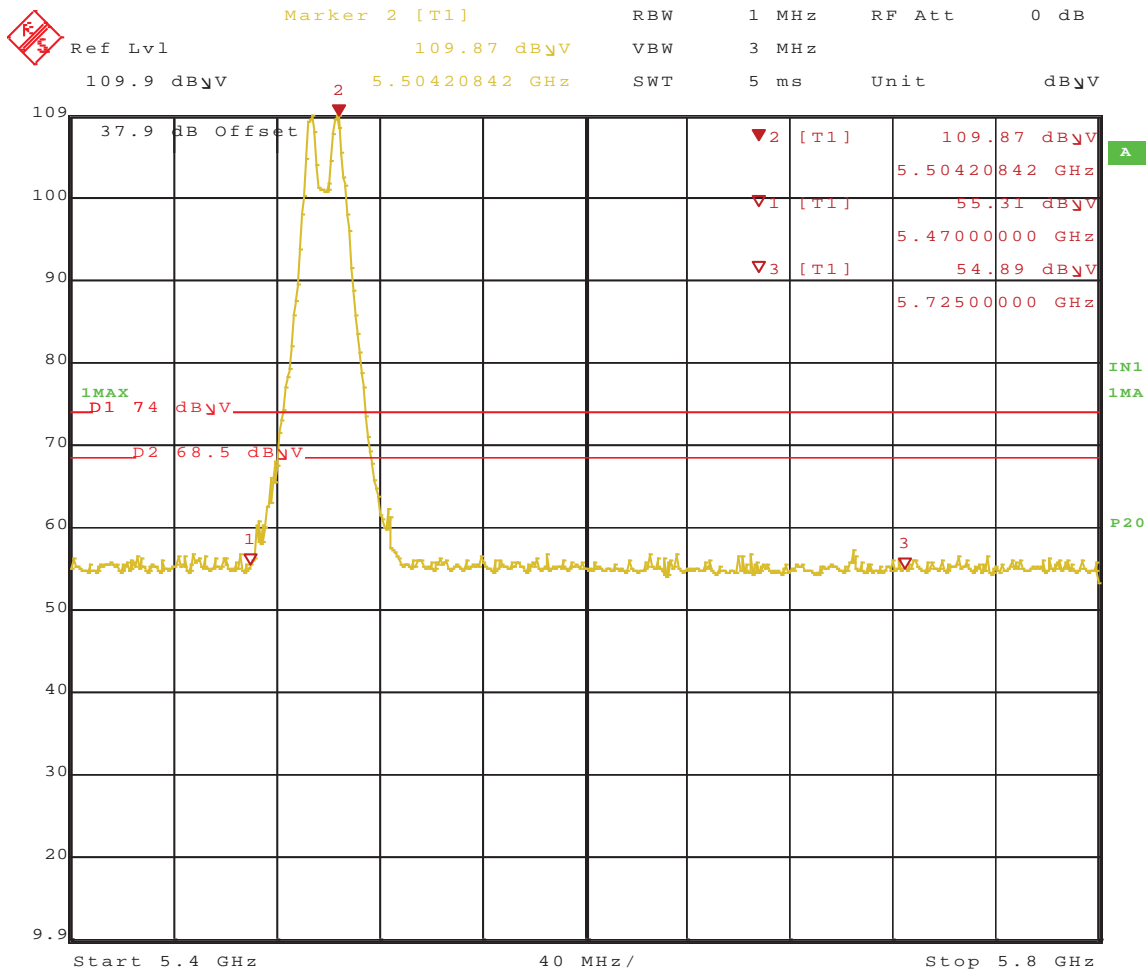

Date: 14.MAR.2011 14:24:48

Figure 603: Radiated Emission at the Edge for 5500 MHz at 19.5Mbps – Vert. (Peak)

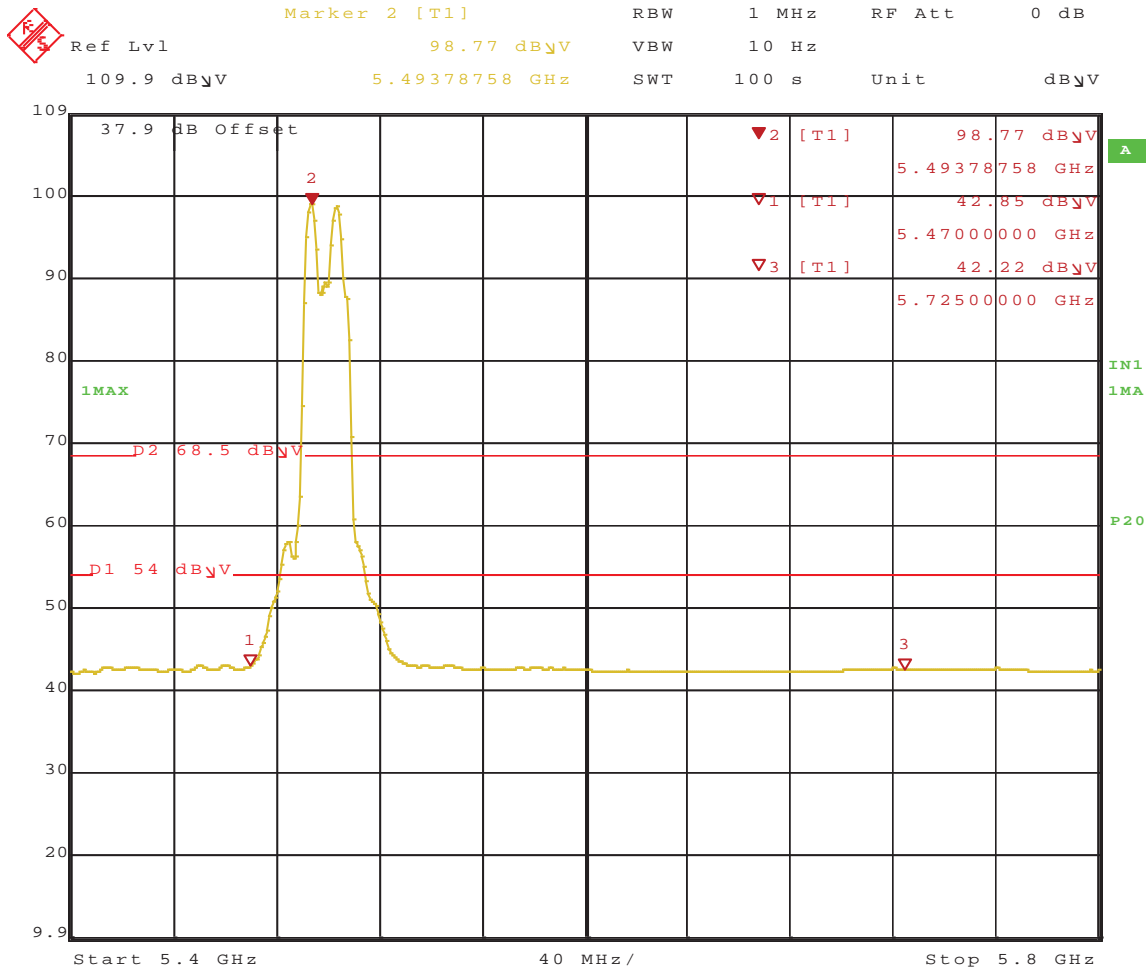

Date: 14.MAR.2011 14:26:51

Figure 604: Radiated Emission at the Edge for 5500 MHz at 19.5Mbps – Vert. (Ave.)

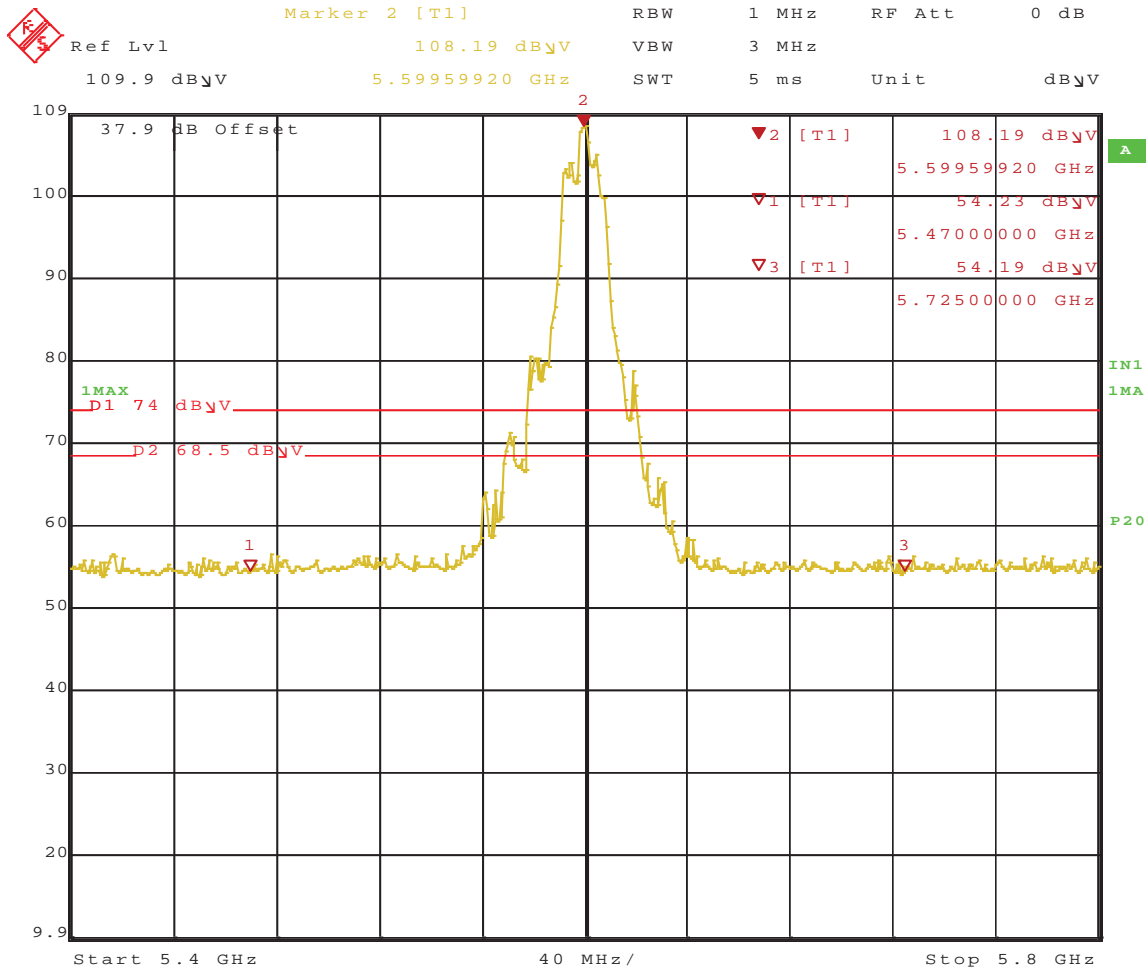

Date: 14.MAR.2011 14:34:36

Figure 605: Radiated Emission at the Edge for 5600 MHz at 19.5Mbps – Horz. (Peak)

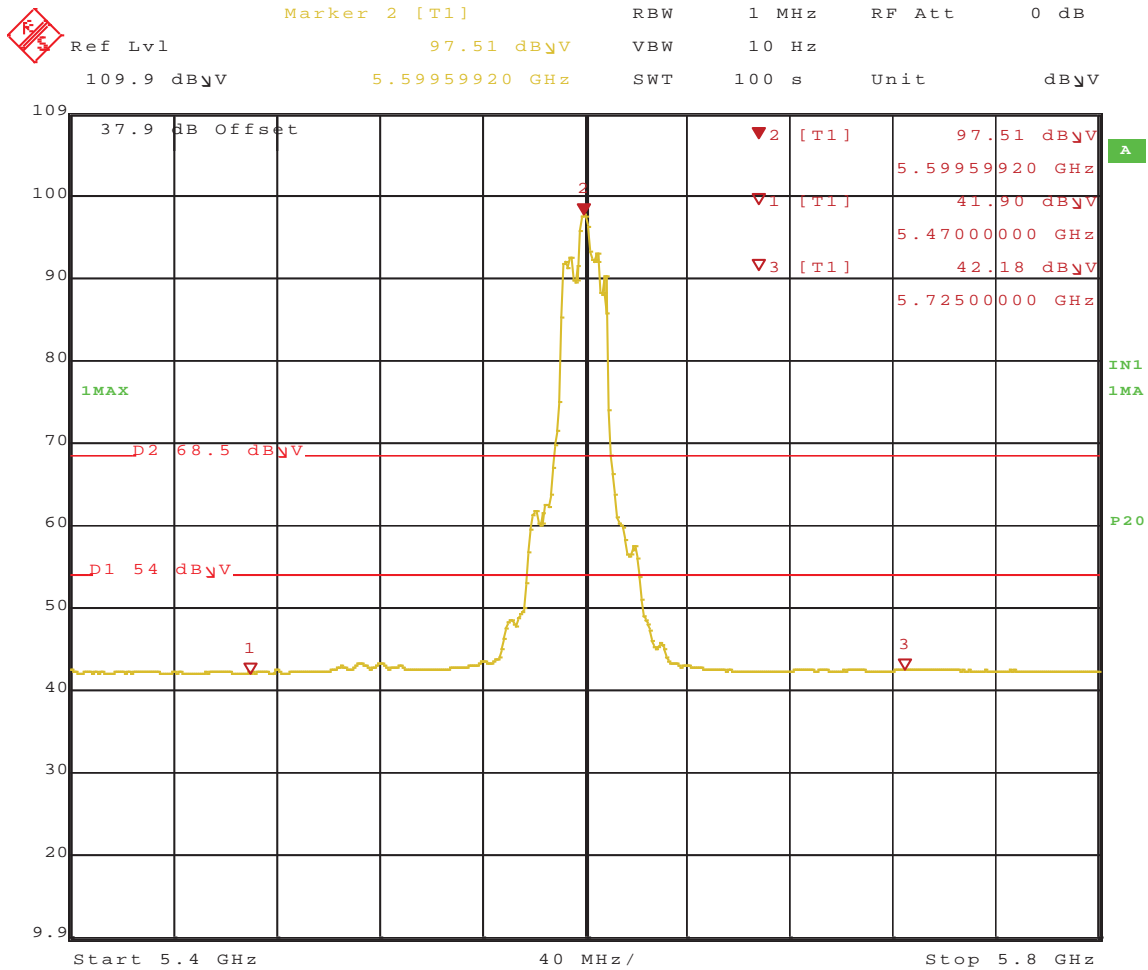

Date: 14.MAR.2011 14:36:34

Figure 606: Radiated Emission at the Edge for 5600 MHz at 19.5Mbps – Horz. (Ave.)

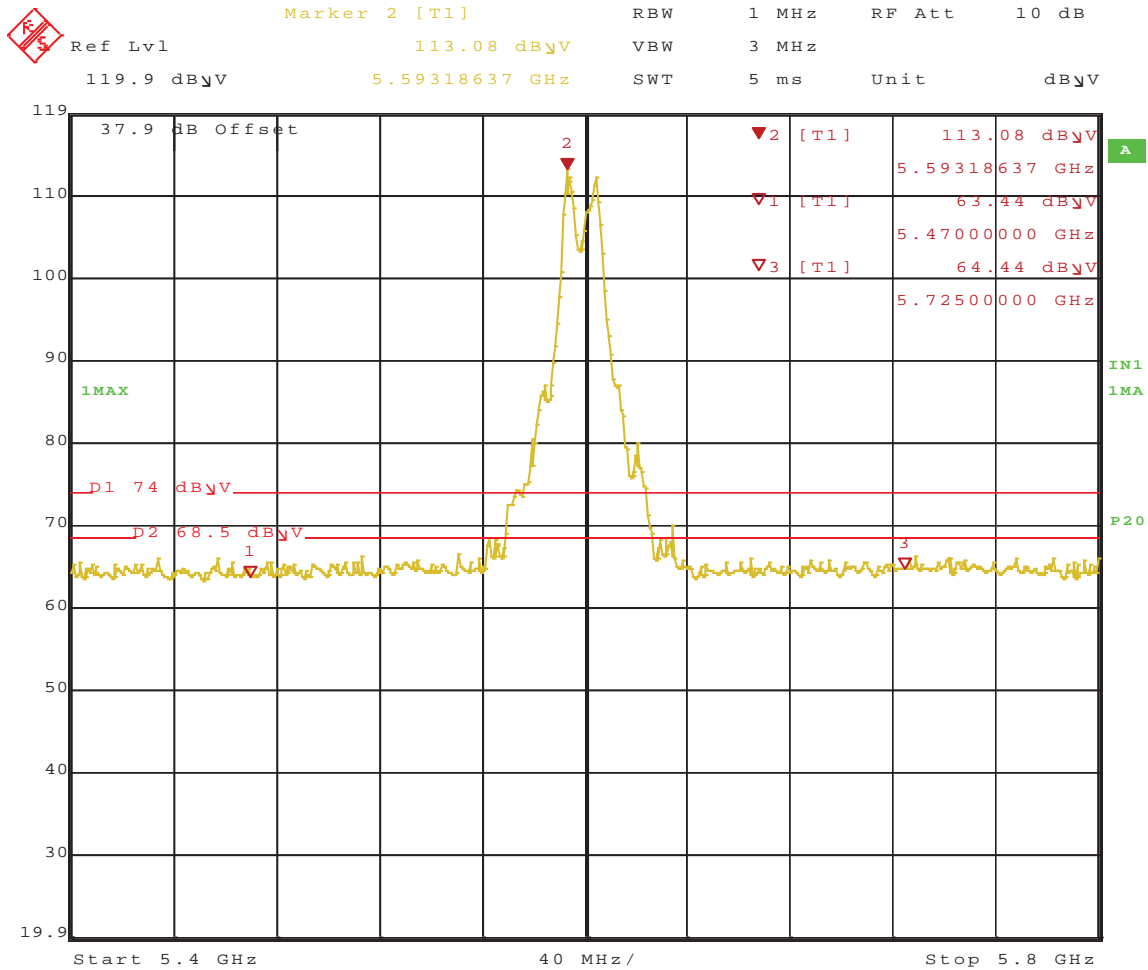

Date: 14.MAR.2011 14:29:18

Figure 607: Radiated Emission at the Edge for 5600 MHz at 19.5Mbps – Vert. (Peak)

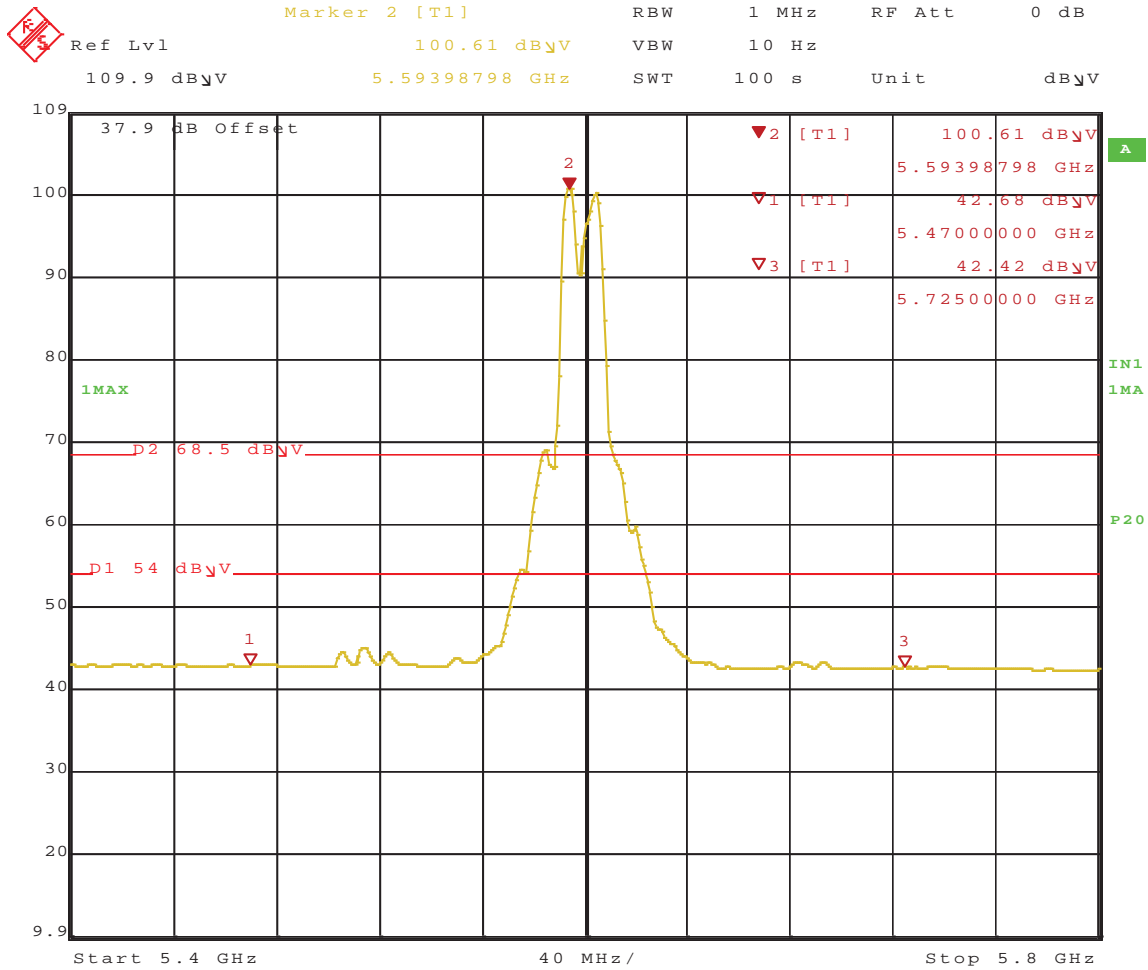

Date: 14.MAR.2011 14:31:42

Figure 608: Radiated Emission at the Edge for 5600 MHz at 19.5Mbps – Vert. (Ave.)

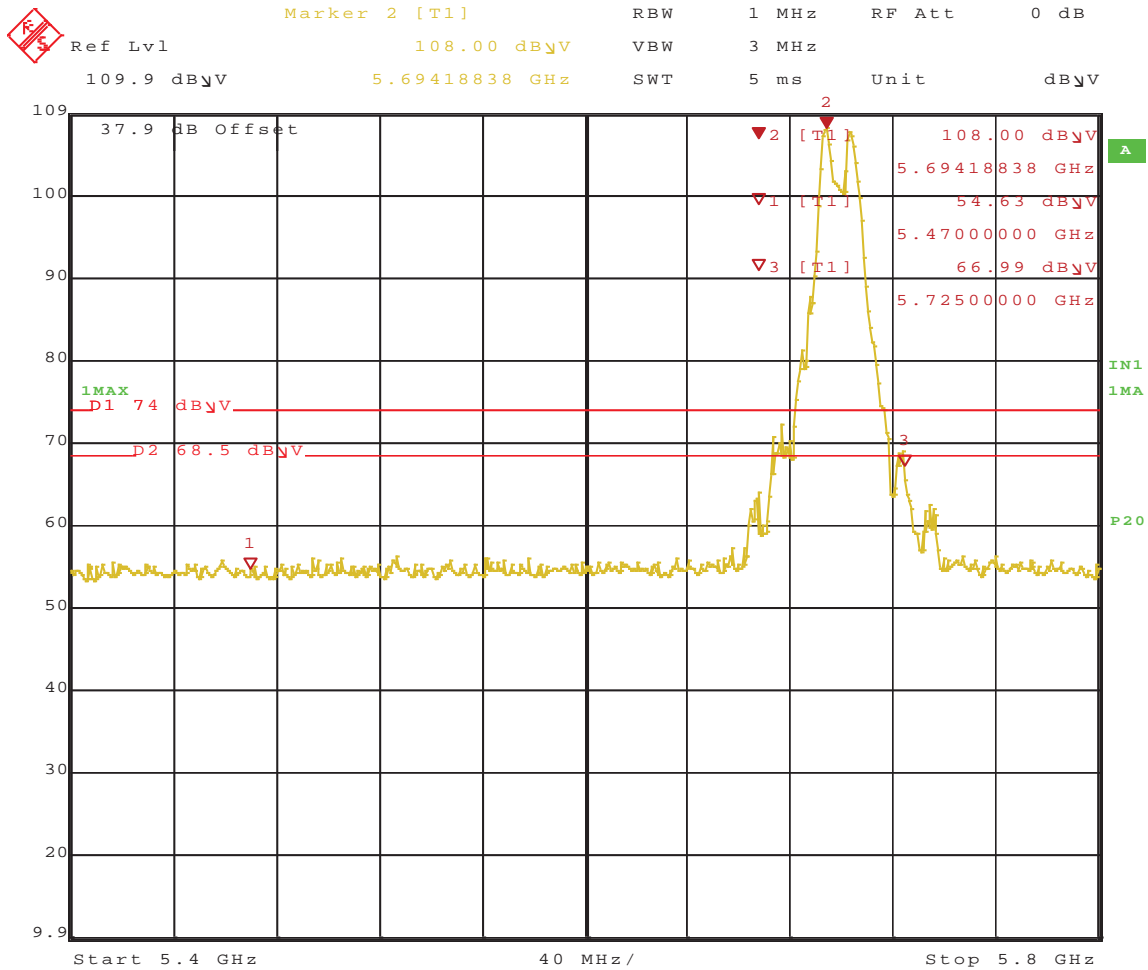

Date: 14.MAR.2011 14:39:46

Figure 609: Radiated Emission at the Edge for 5700 MHz at 19.5Mbps – Horz. (Peak)

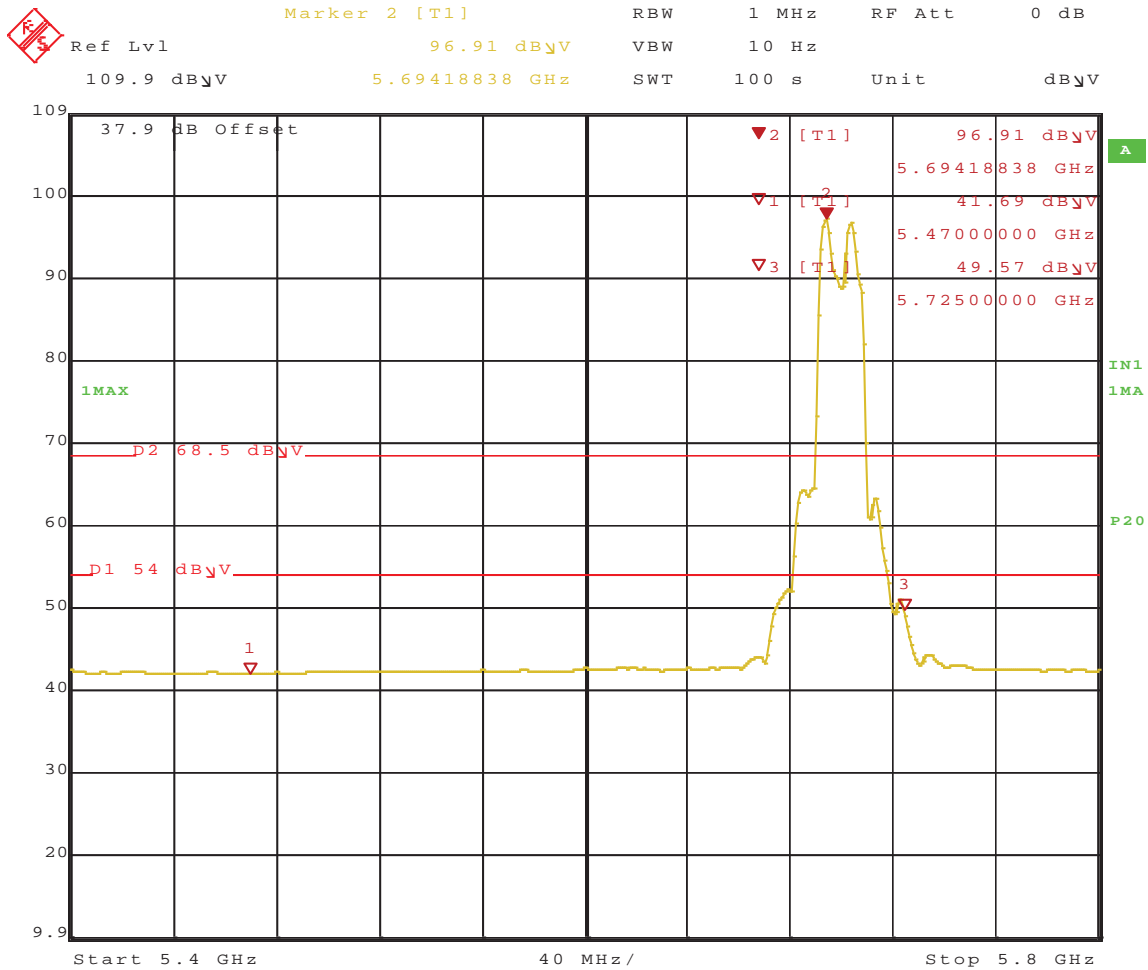

Date: 14.MAR.2011 14:41:58

Figure 610: Radiated Emission at the Edge for 5700 MHz at 19.5Mbps – Horz. (Ave.)

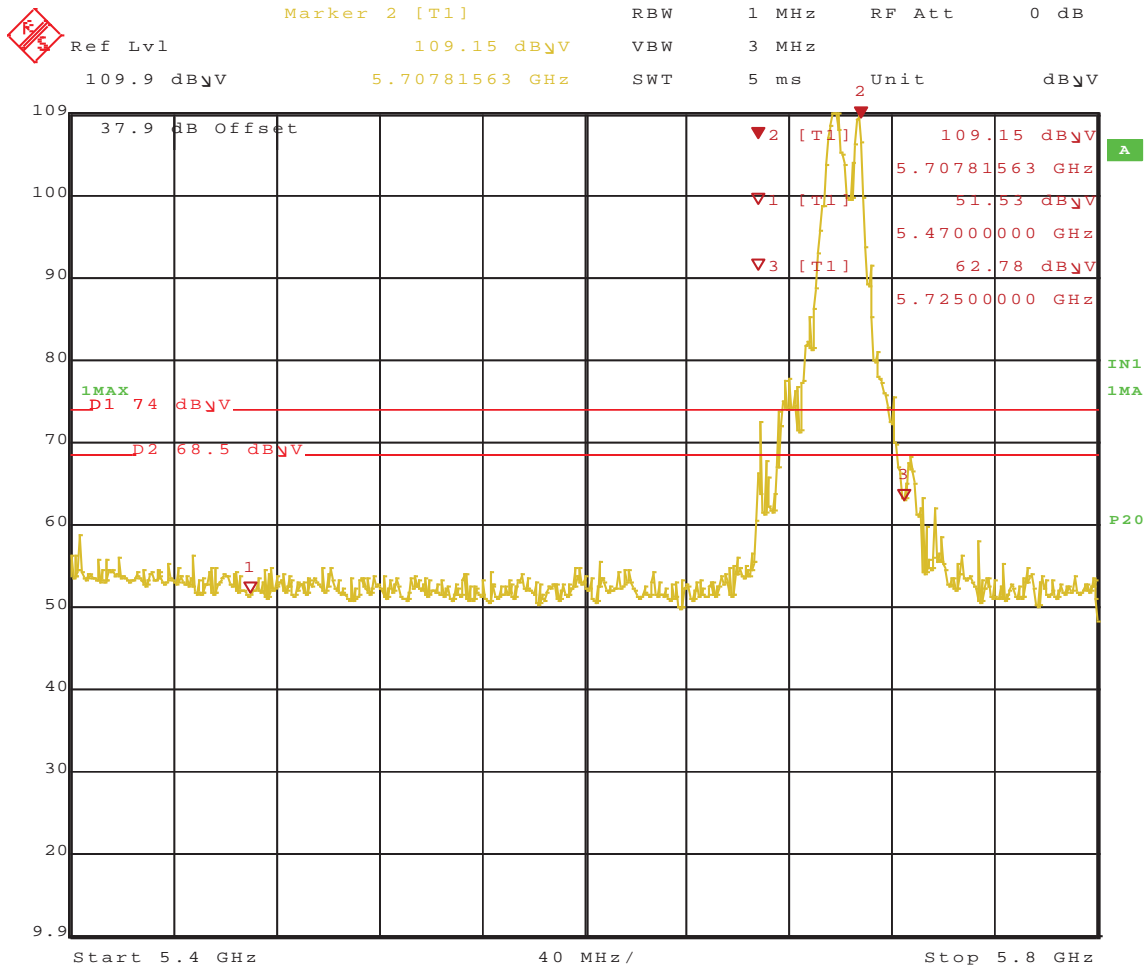

Date: 14.MAR.2011 14:47:19

Figure 611: Radiated Emission at the Edge for 5700 MHz at 19.5Mbps – Vert. (Peak)

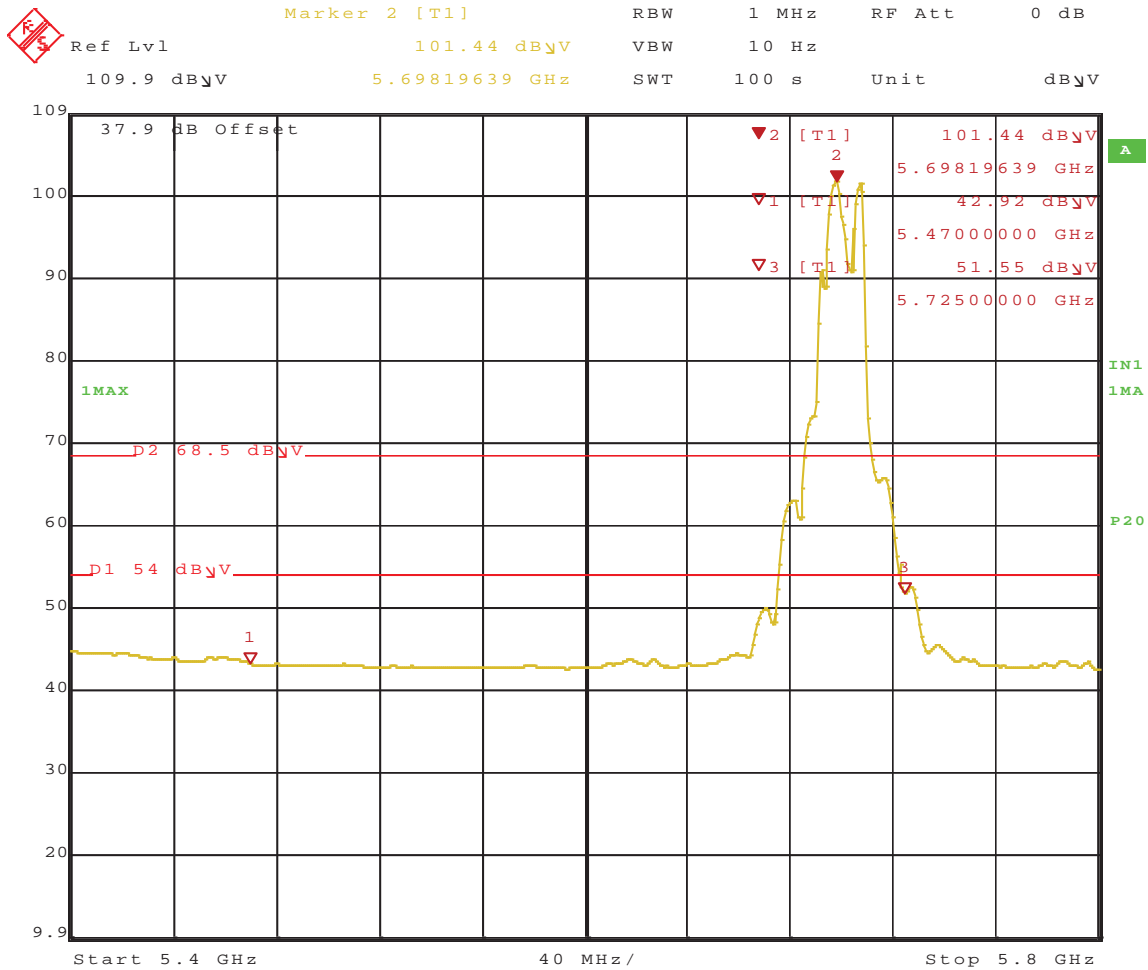

Date: 14.MAR.2011 14:50:32

Figure 612: Radiated Emission at the Edge for 5700 MHz at 19.5Mbps – Vert. (Ave.)

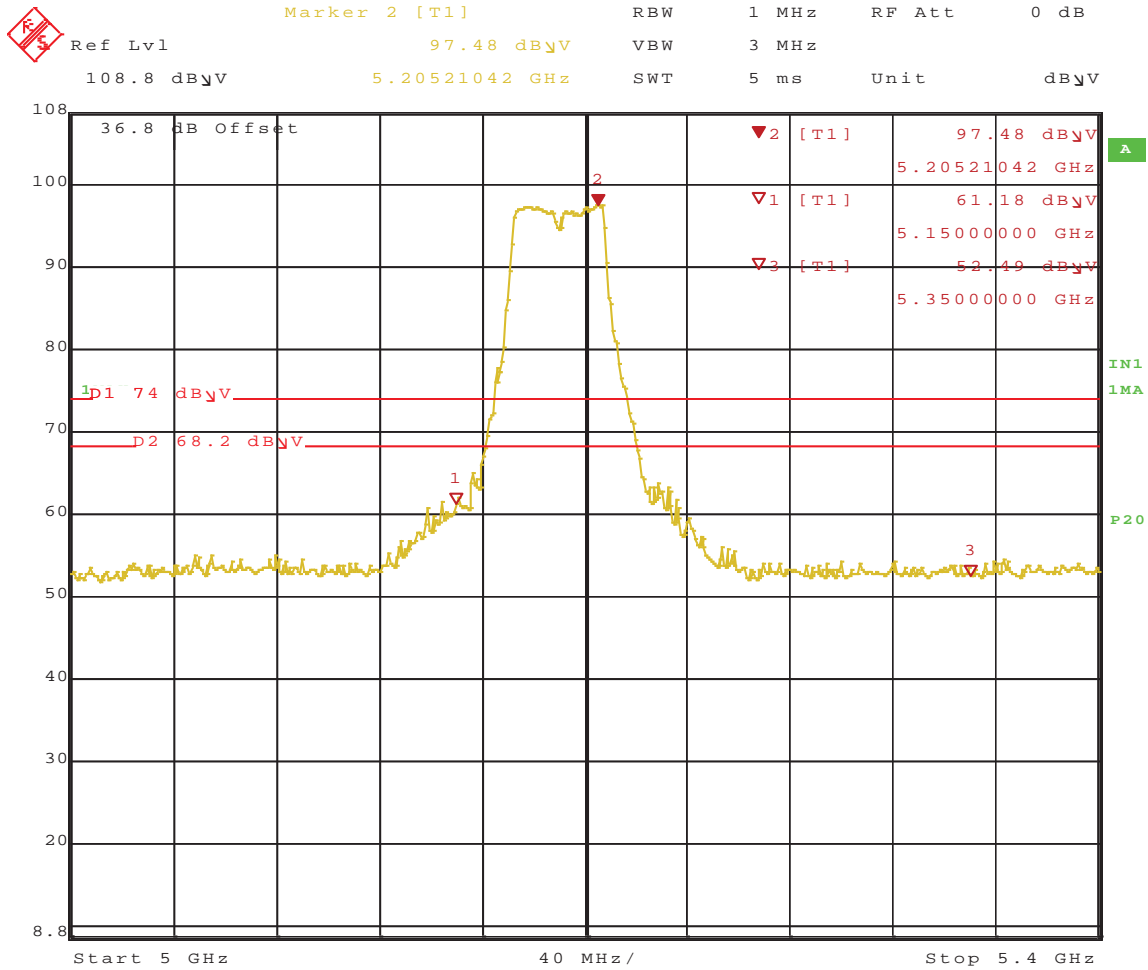

Date: 14.MAR.2011 15:25:50

Figure 613: Radiated Emission at the Edge for Channel 5190 MHz at 13.5Mbps – Horz. (Peak)

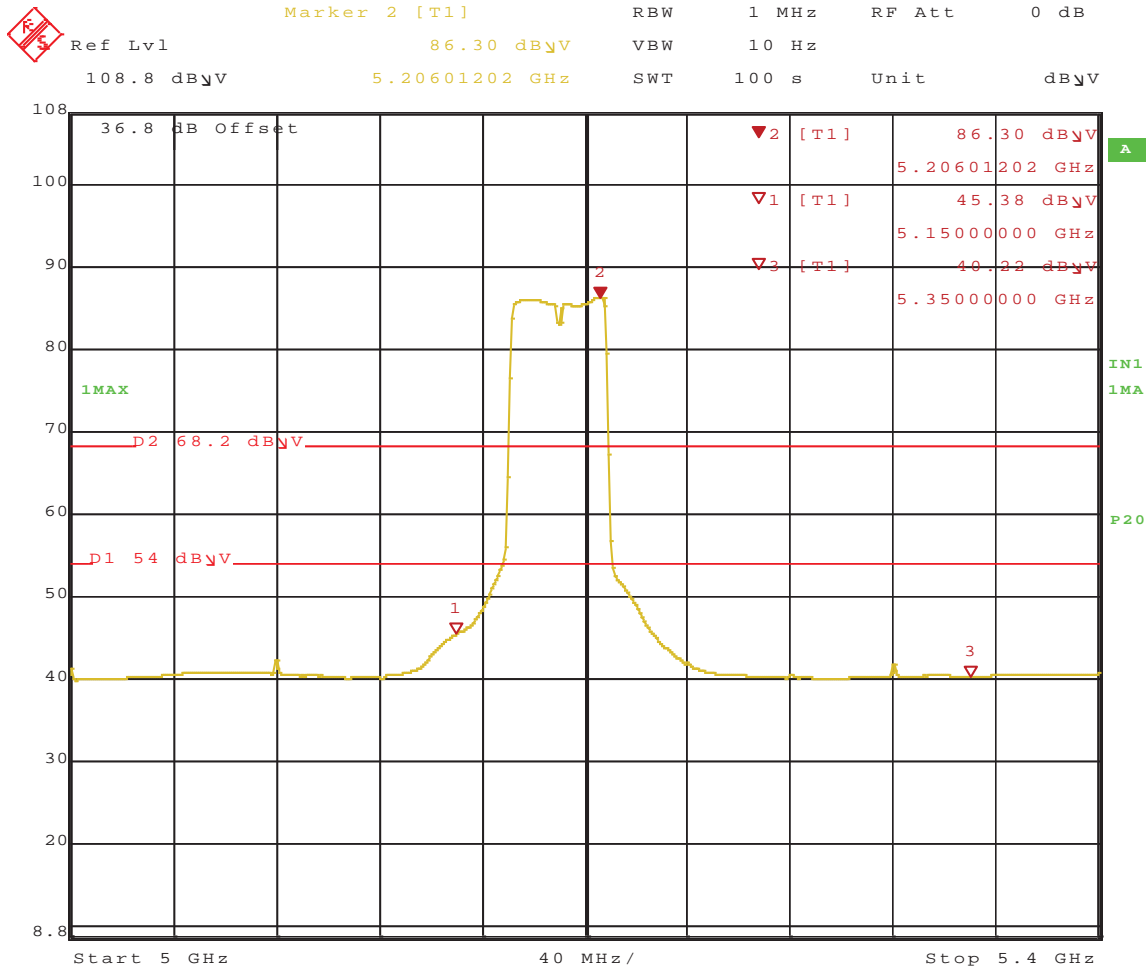

Date: 14.MAR.2011 15:28:16

Figure 614: Radiated Emission at the Edge for Channel 5190 MHz at 13.5Mbps – Horz. (Ave.)

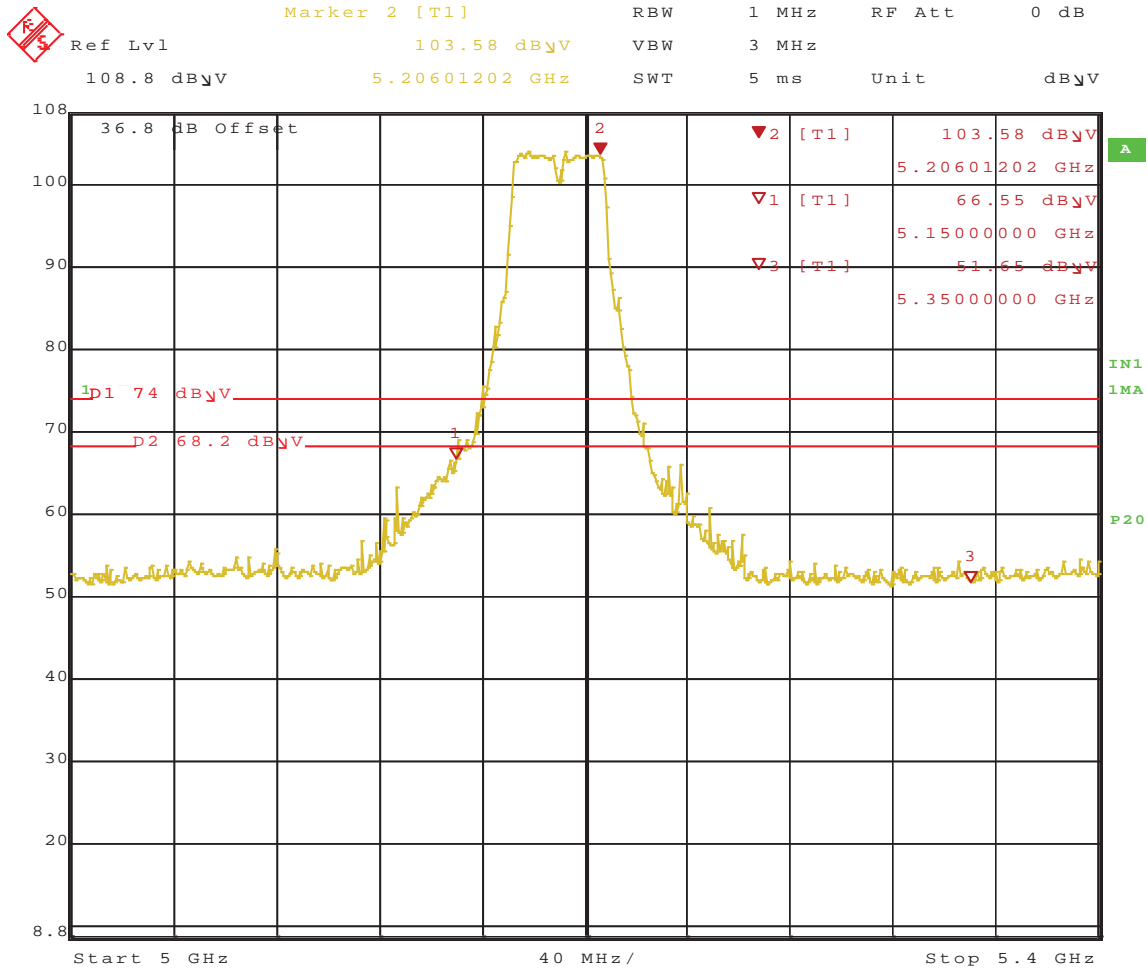

Date: 14.MAR.2011 15:30:11

Figure 615: Radiated Emission at the Edge for Channel 5190 MHz at 13.5Mbps – Vert. (Peak)

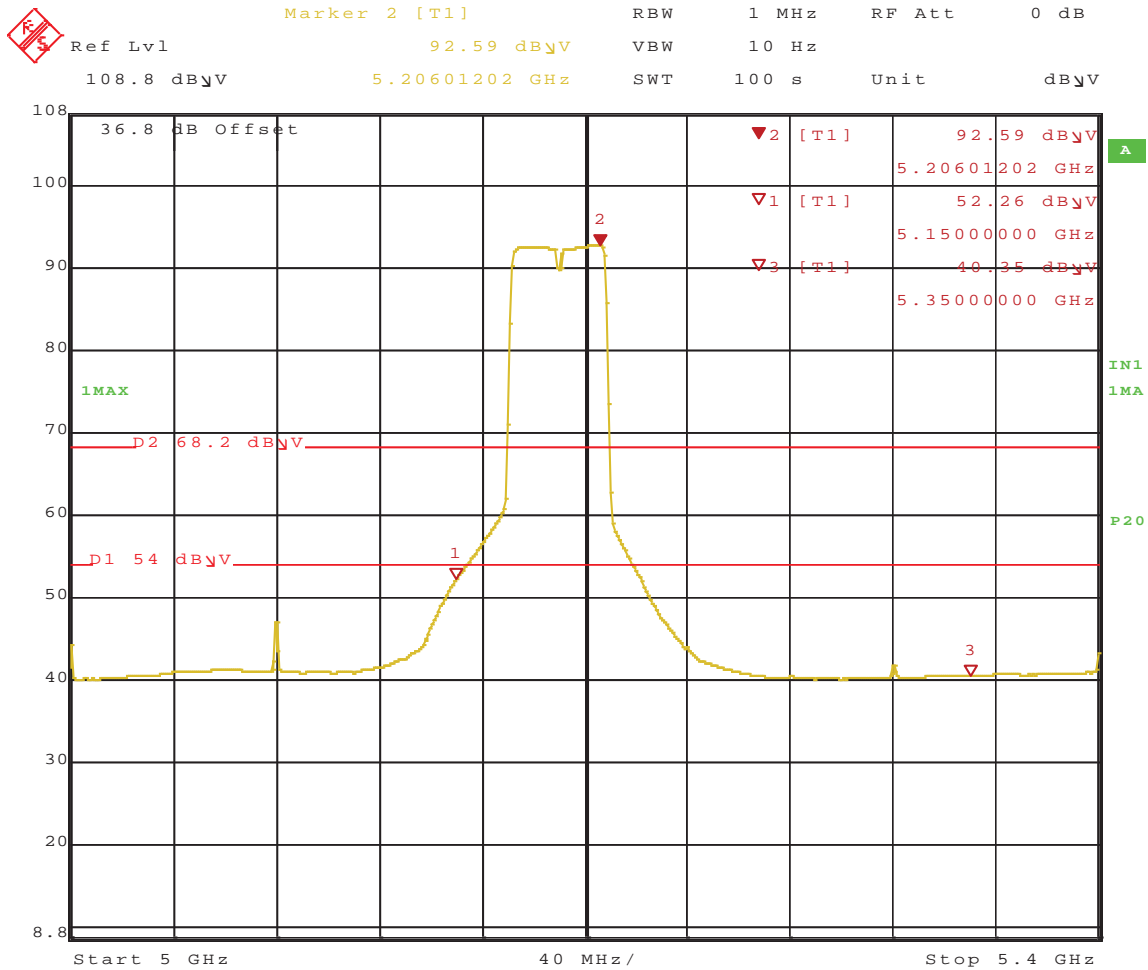

Date: 14.MAR.2011 15:32:33

Figure 616: Radiated Emission at the Edge for Channel 5190 MHz at 13.5Mbps – Vert. (Ave.)

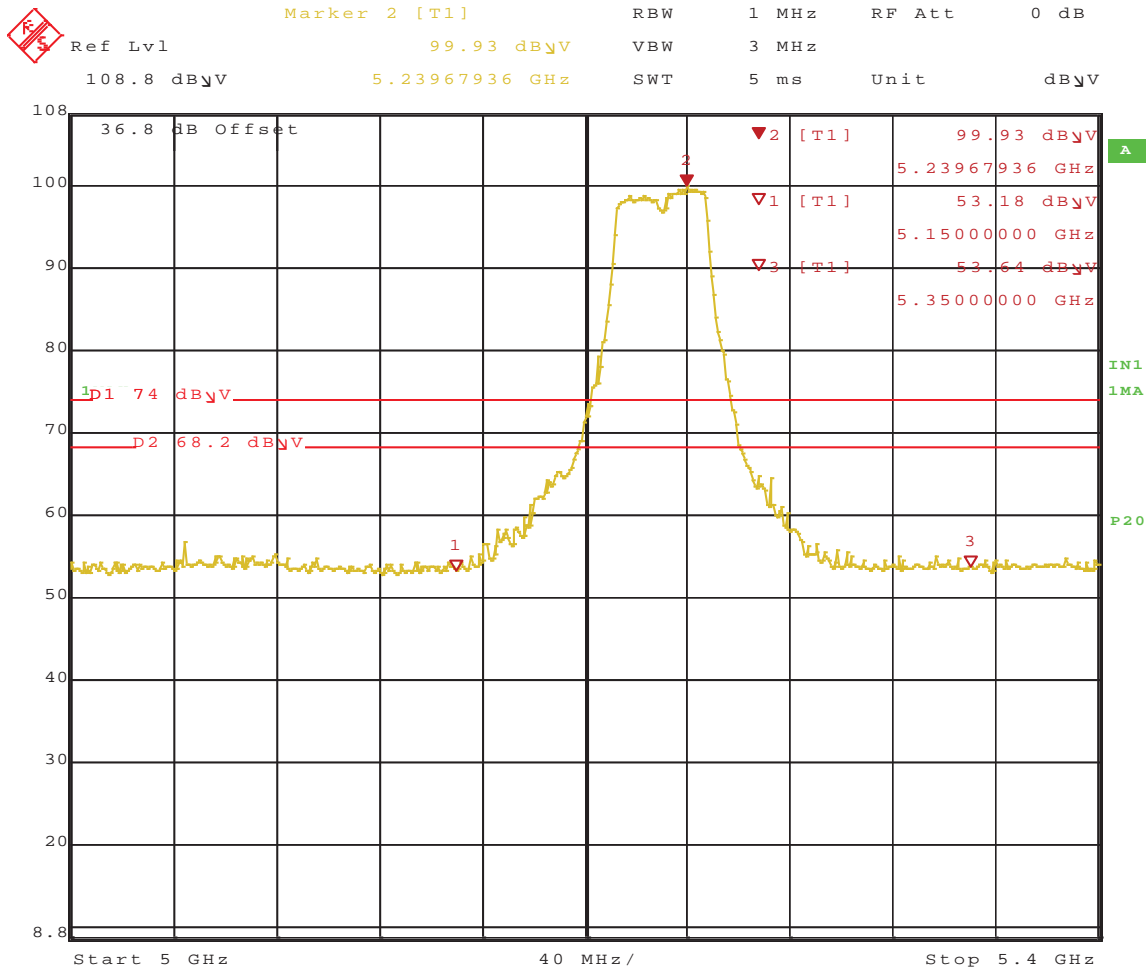

Date: 14.MAR.2011 15:40:38

Figure 617: Radiated Emission at the Edge for Channel 5230 MHz at 13.5Mbps – Horz. (Peak)

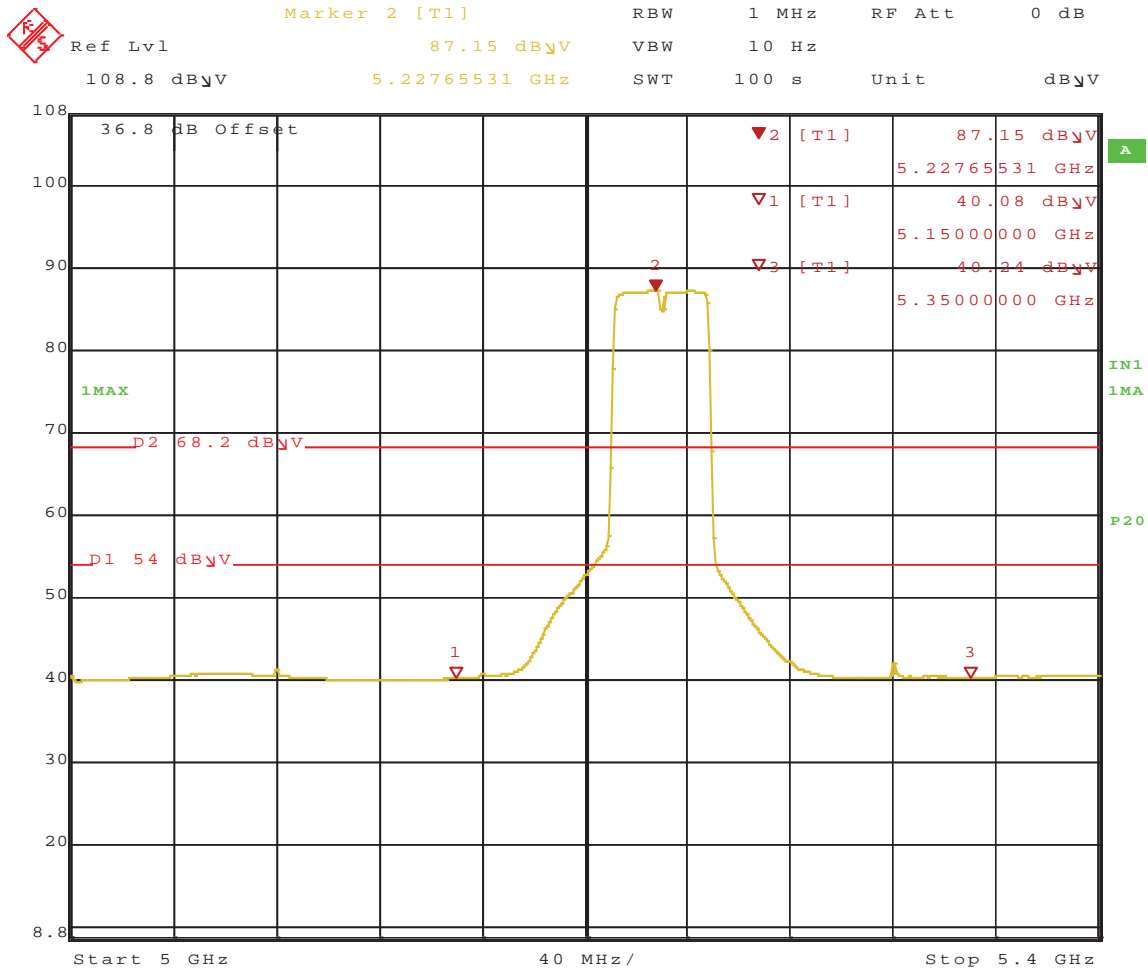

Date: 14.MAR.2011 15:42:35

Figure 618: Radiated Emission at the Edge for Channel 5230 MHz at 13.5Mbps – Horz. (Ave.)

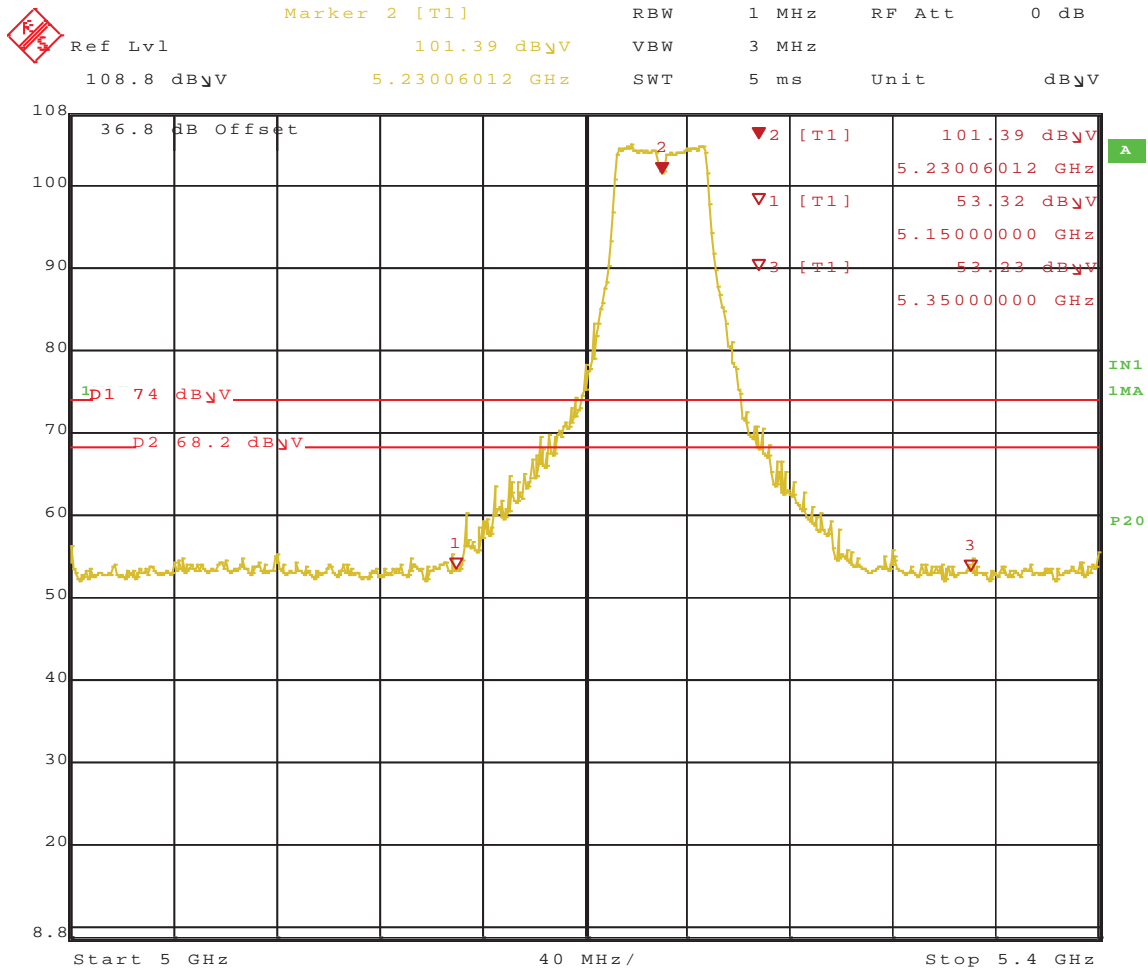
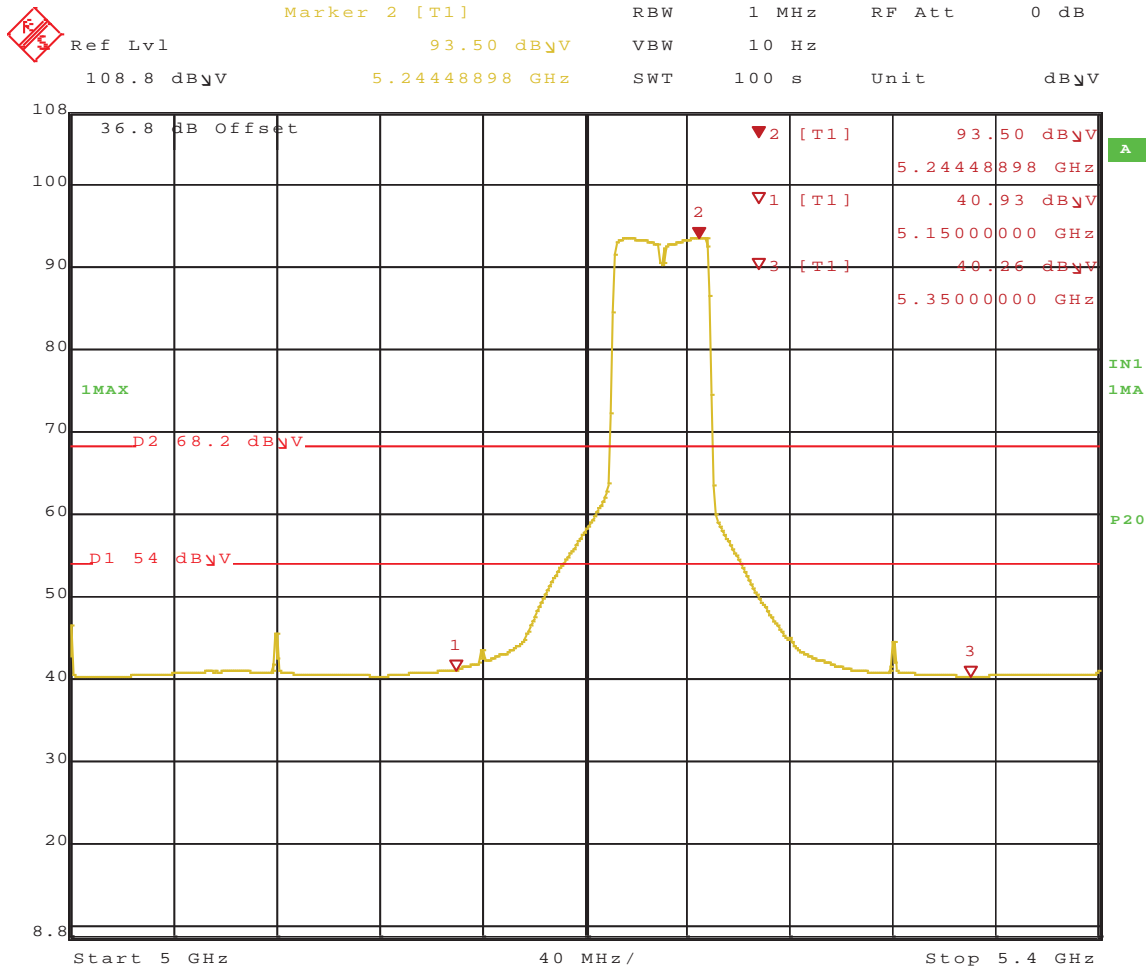
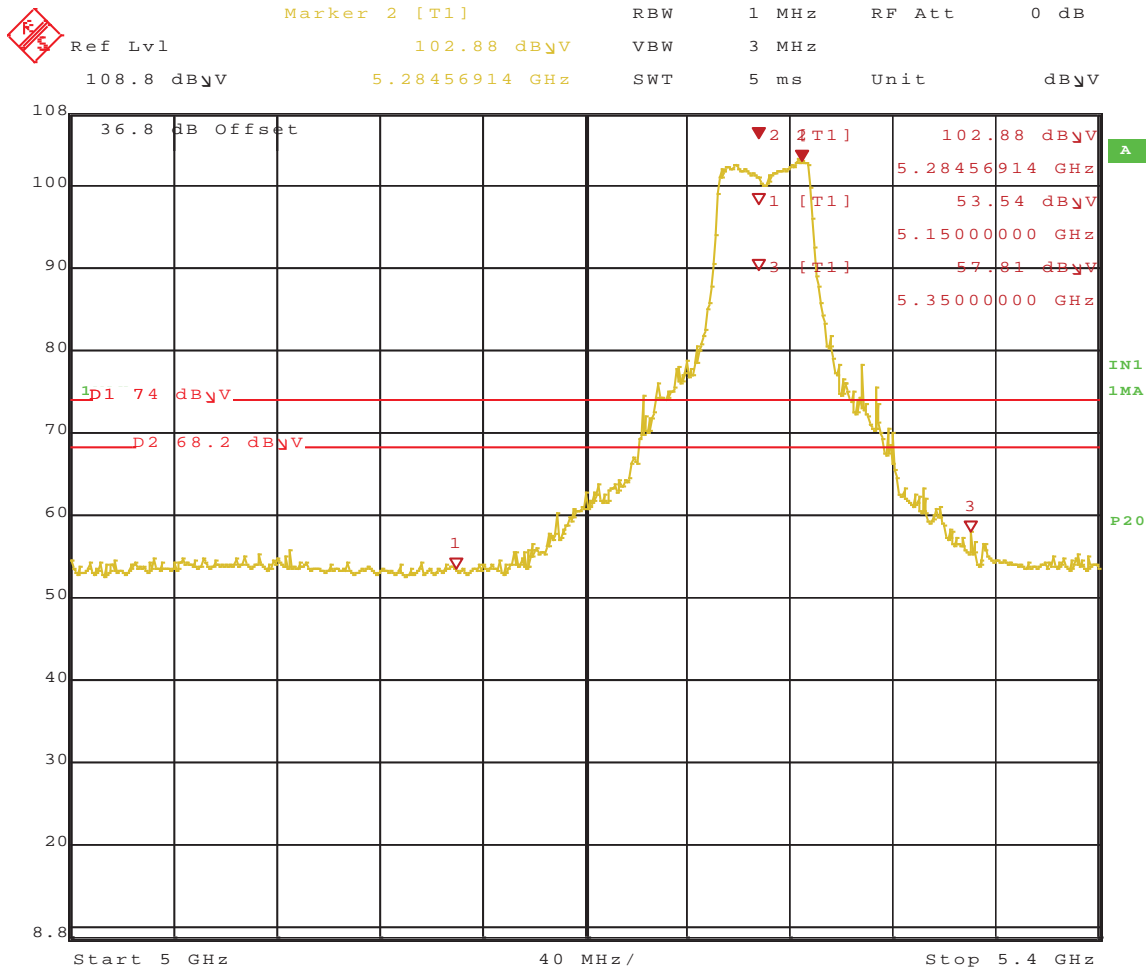

Figure 619: Radiated Emission at the Edge for Channel 5230 MHz at 13.5Mbps – Vert. (Peak)



Date: 14.MAR.2011 15:37:48

Figure 620: Radiated Emission at the Edge for Channel 5230 MHz at 13.5Mbps – Vert. (Ave.)



Date: 14.MAR.2011 15:44:49

Figure 621: Radiated Emission at the Edge for Channel 5270 MHz at 13.5Mbps – Horz. (Peak)

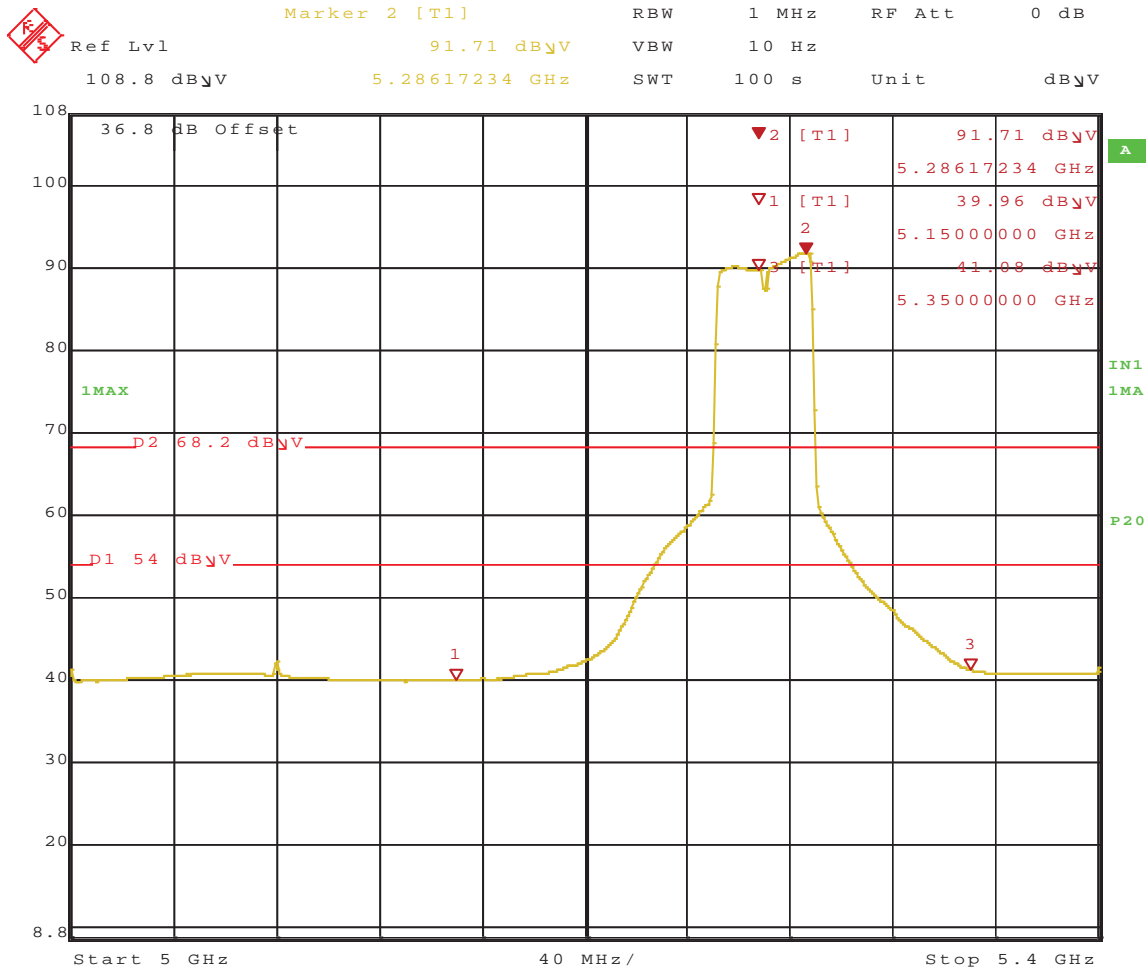

Date: 14.MAR.2011 15:46:53

Figure 622: Radiated Emission at the Edge for Channel 5270 MHz at 13.5Mbps – Horz. (Ave.)

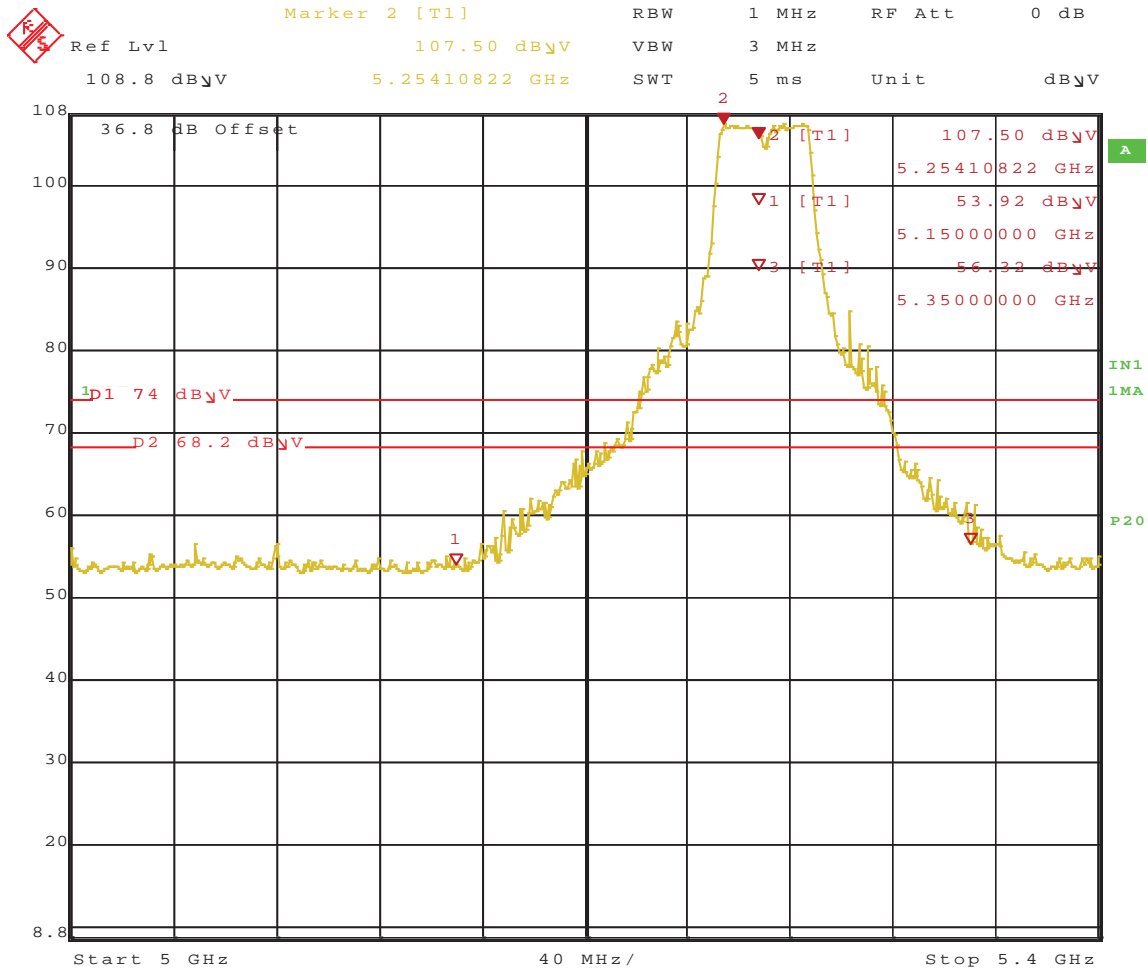

Date: 14.MAR.2011 15:48:43

Figure 623: Radiated Emission at the Edge for Channel 5270 MHz at 13.5Mbps – Vert. (Peak)

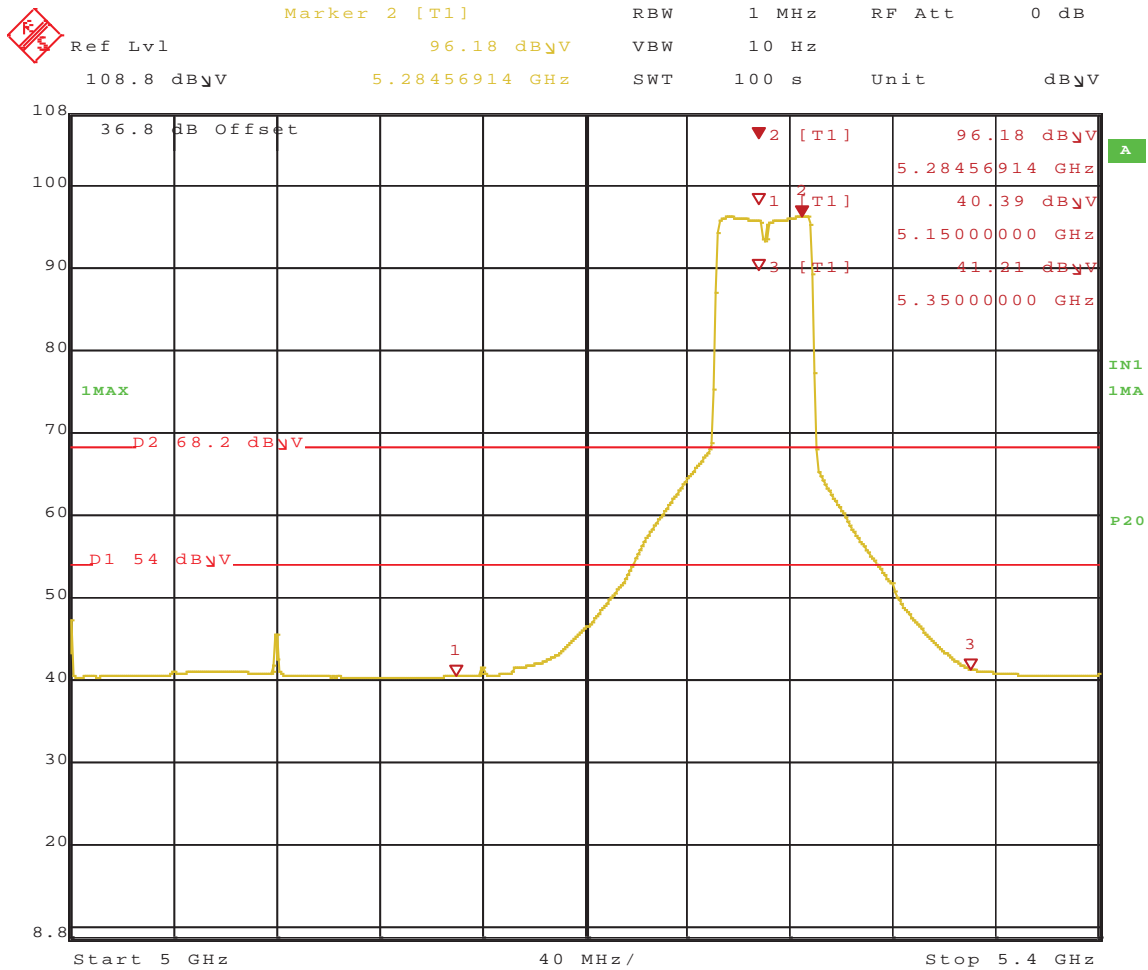

Date: 14.MAR.2011 15:50:42

Figure 624: Radiated Emission at the Edge for Channel 5270 MHz at 13.5Mbps – Vert. (Ave.)

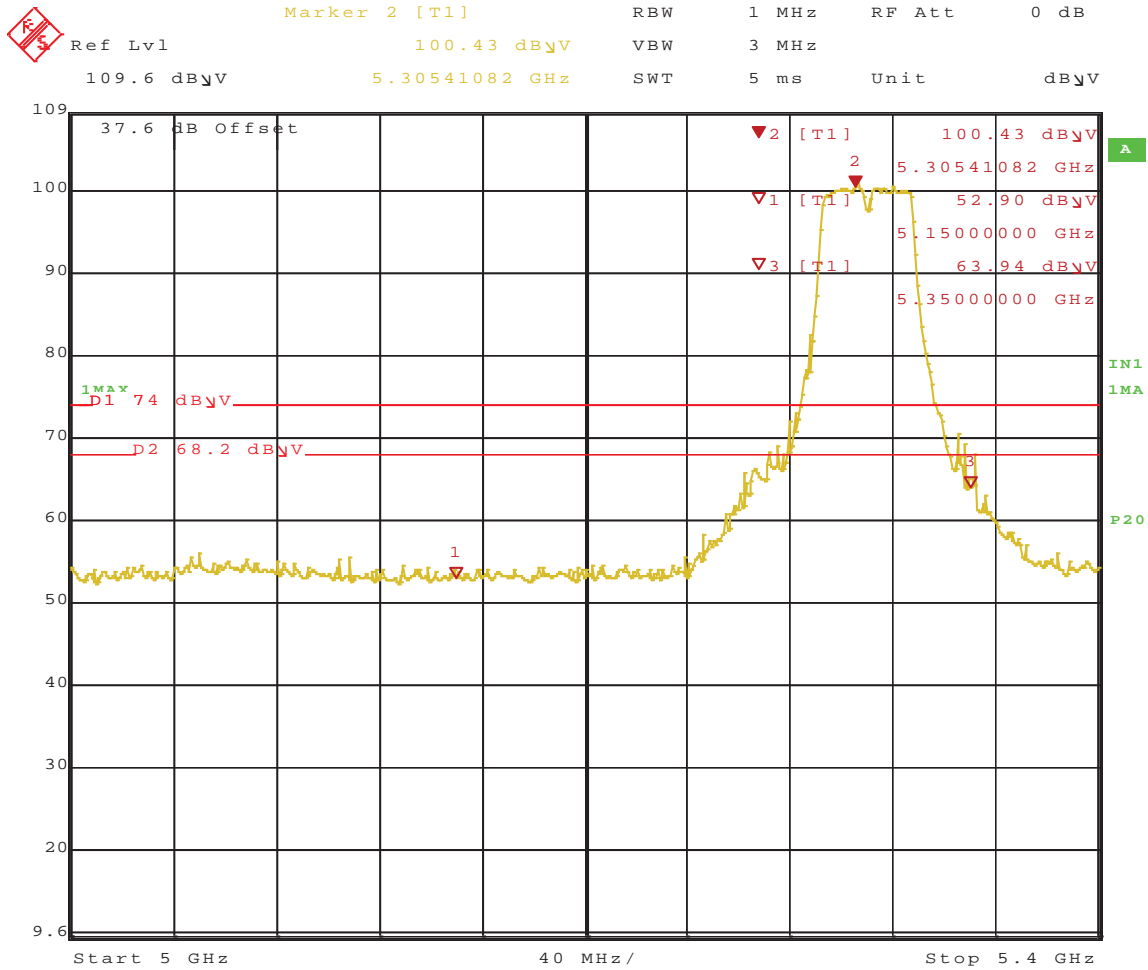

Date: 15.MAR.2011 09:38:39

Figure 625: Radiated Emission at the Edge for Channel 5310 MHz at 13.5Mbps – Horz (Peak)

Note: Reduce power to 11 dBm

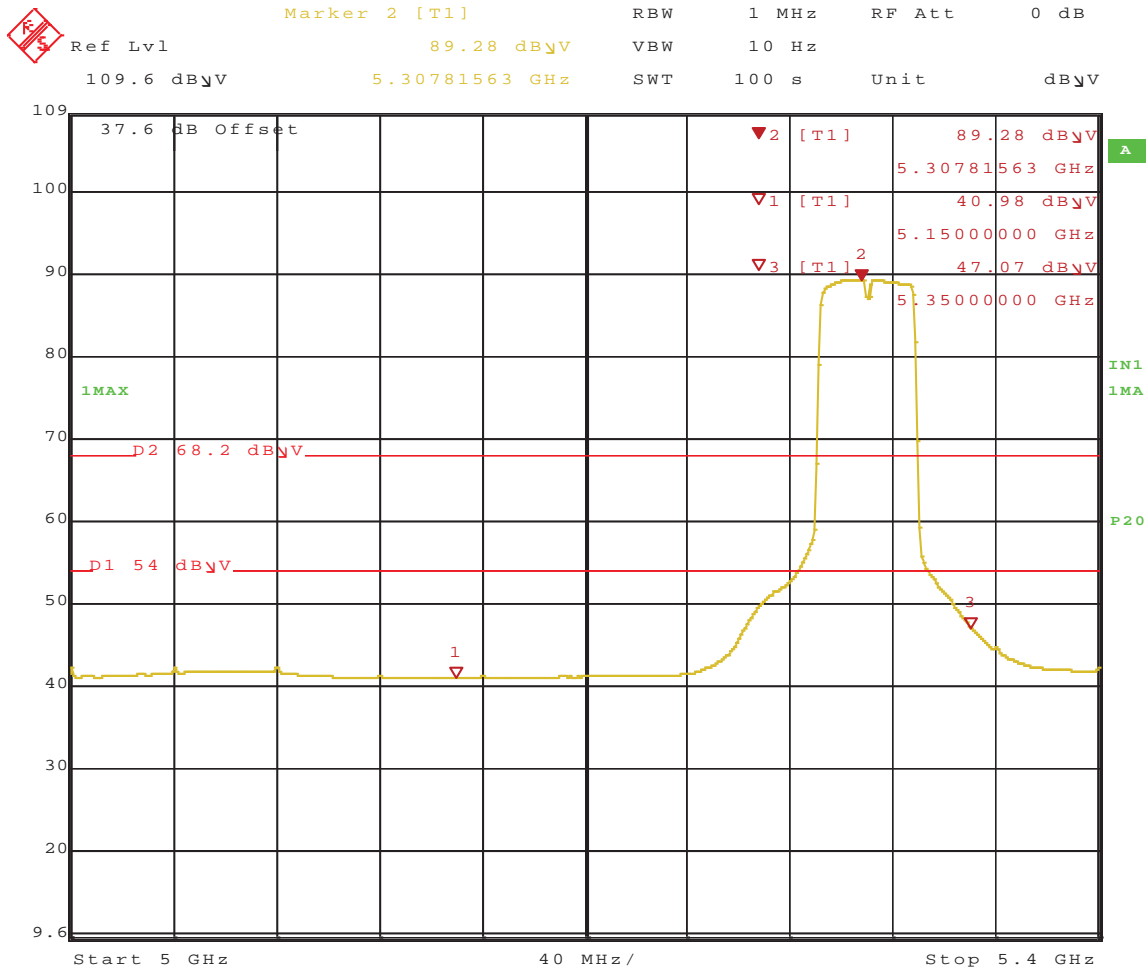

Date: 15.MAR.2011 09:41:25

Figure 626: Radiated Emission at the Edge for Channel 5310 MHz at 13.5Mbps – Horz (Ave.)

Note: Reduce power to 11 dBm

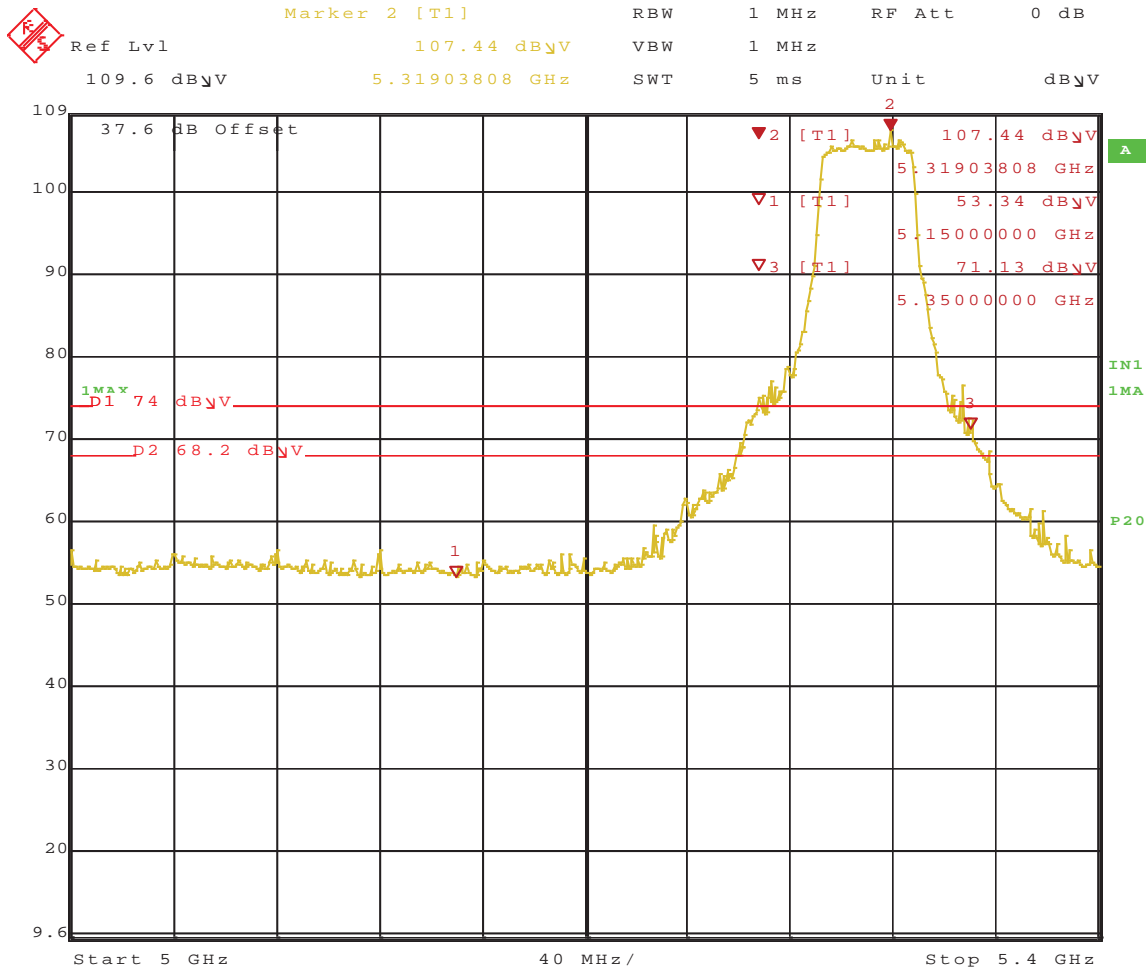

Date: 15.MAR.2011 08:33:16

Figure 627: Radiated Emission at the Edge for Channel 5310 MHz at 13.5Mbps – Vert (Peak)

Note: Reduce power to 11 dBm

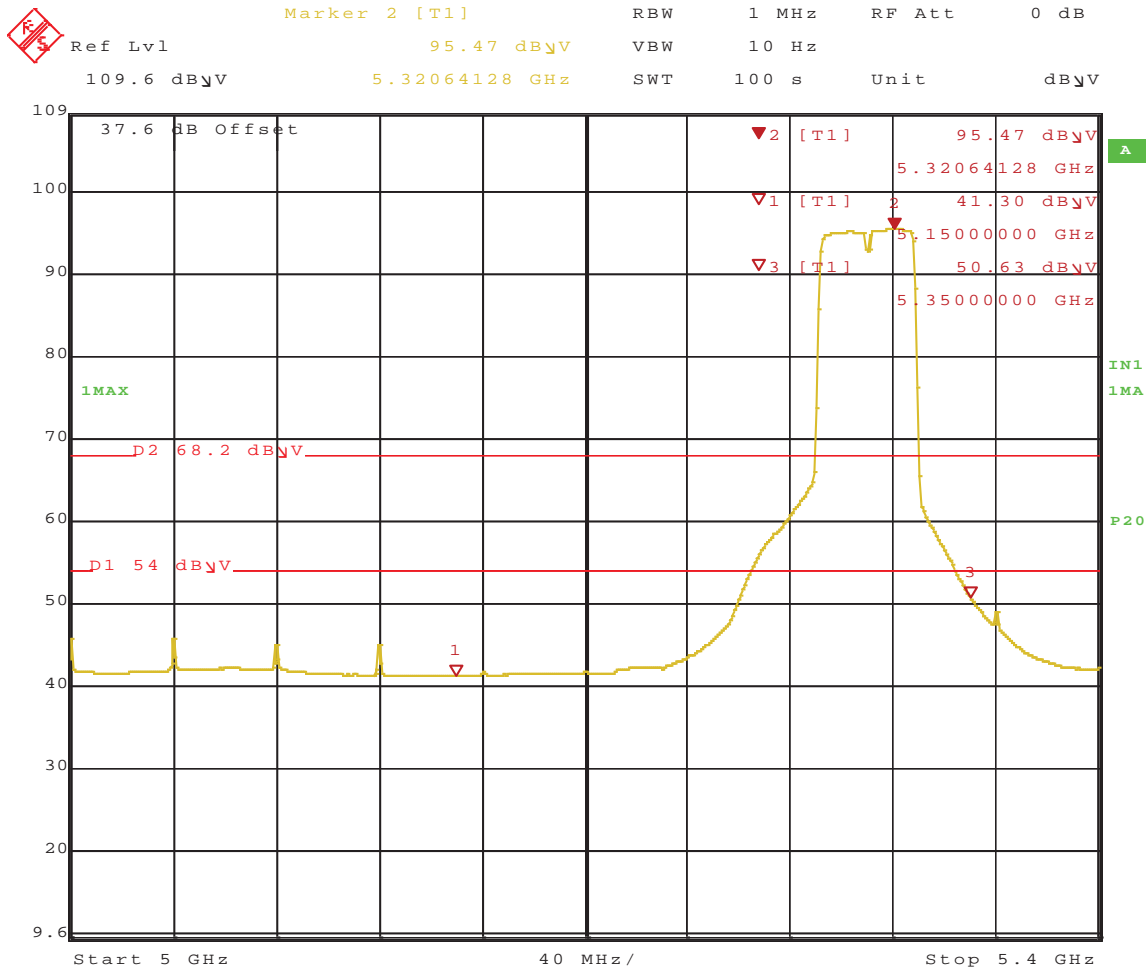

Date: 15.MAR.2011 08:36:35

Figure 628: Radiated Emission at the Edge for Channel 5310 MHz at 13.5Mbps – Vert (Ave.)

Note: Reduce power to 11 dBm

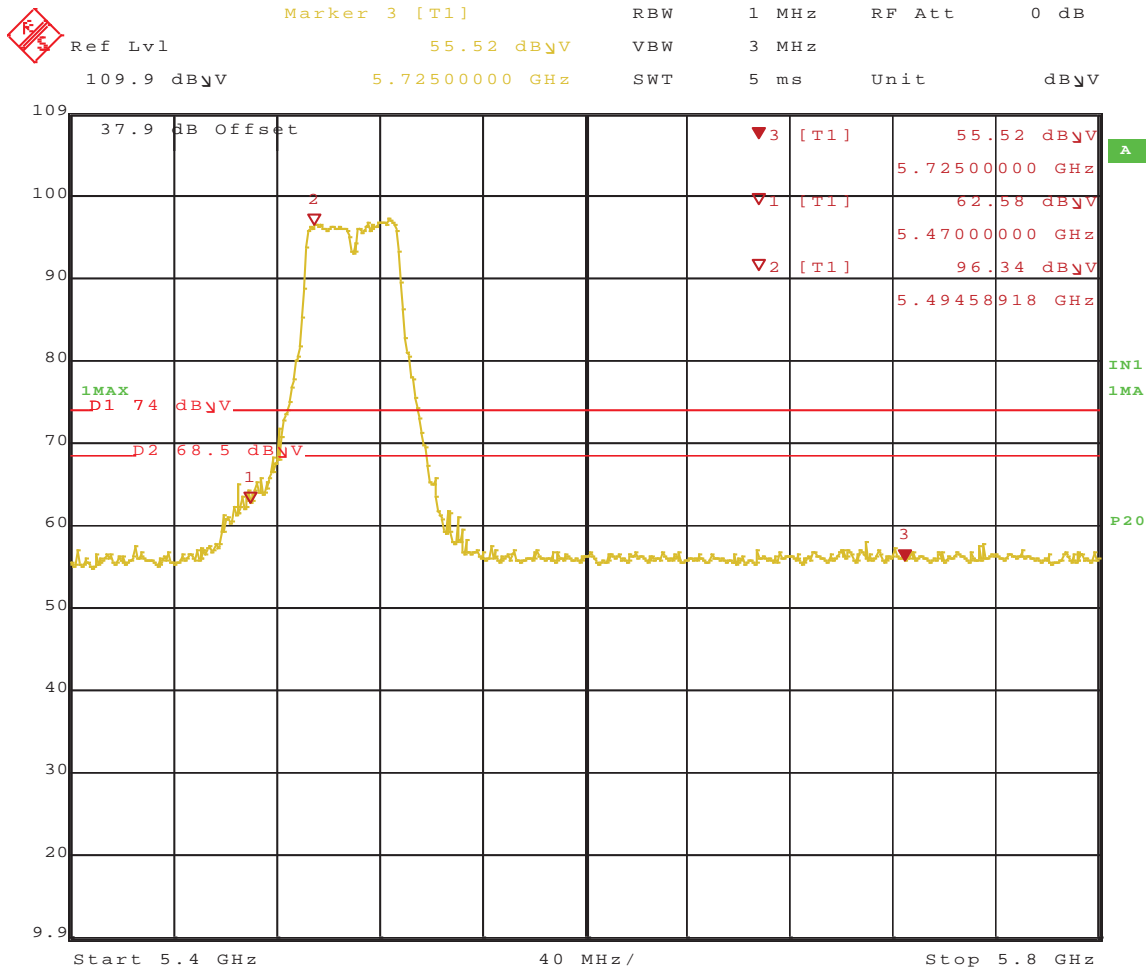

Date: 15.MAR.2011 09:47:39

Figure 629: Radiated Emission at the Edge for Channel 5510 MHz at 13.5Mbps – Horz. (Peak)

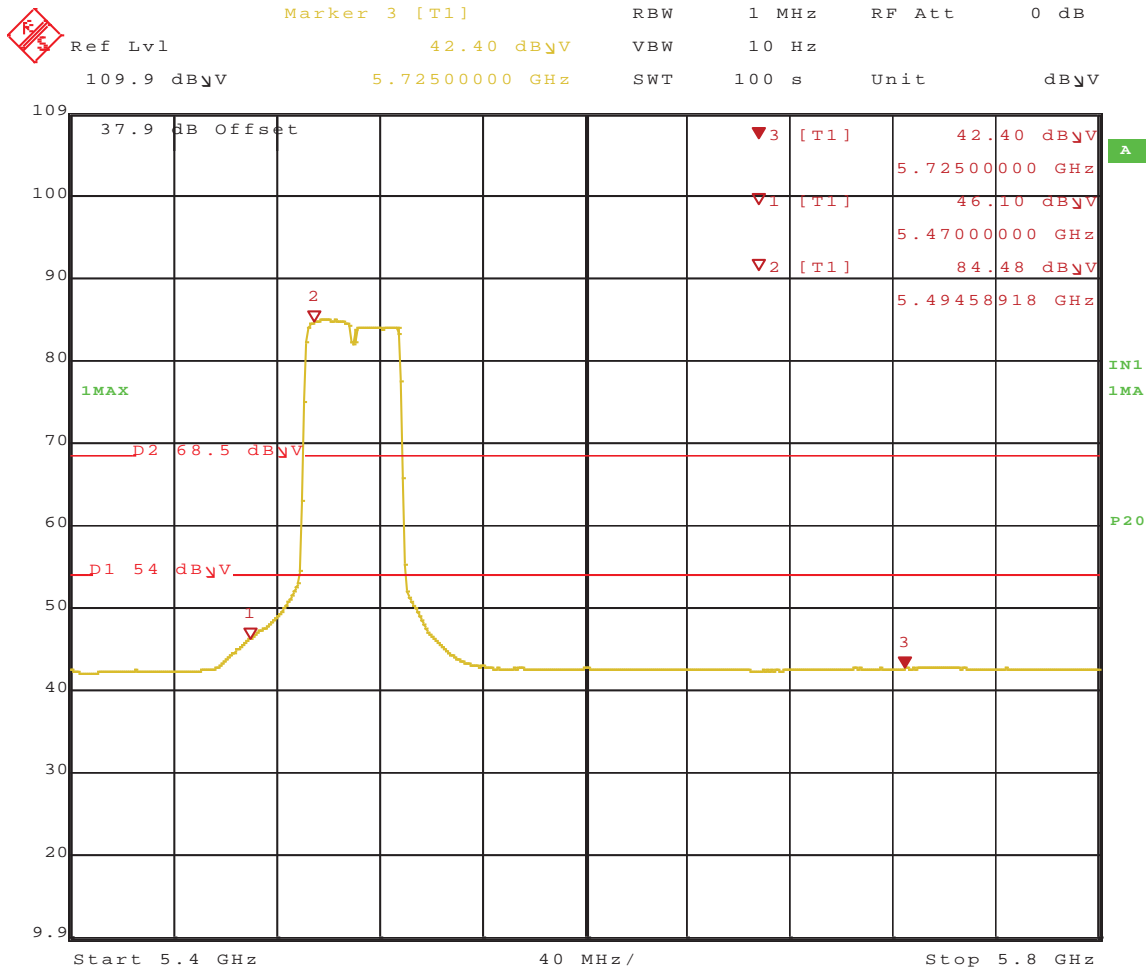

Date: 15.MAR.2011 09:50:00

Figure 630: Radiated Emission at the Edge for Channel 5510 MHz at 13.5Mbps – Horz. (Ave.)

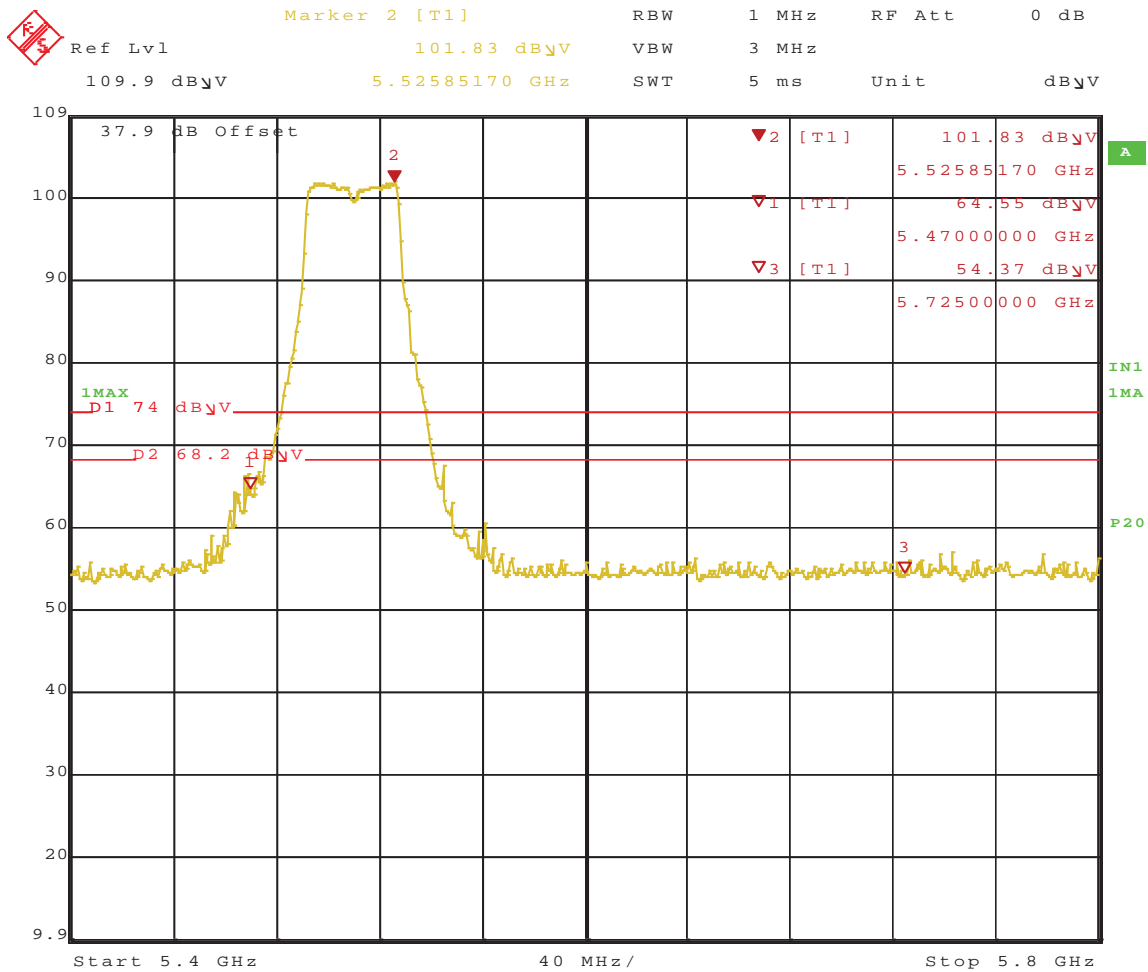

Date: 15.MAR.2011 09:55:26

Figure 631: Radiated Emission at the Edge for Channel 5510 MHz at 13.5Mbps – Vert. (Peak)

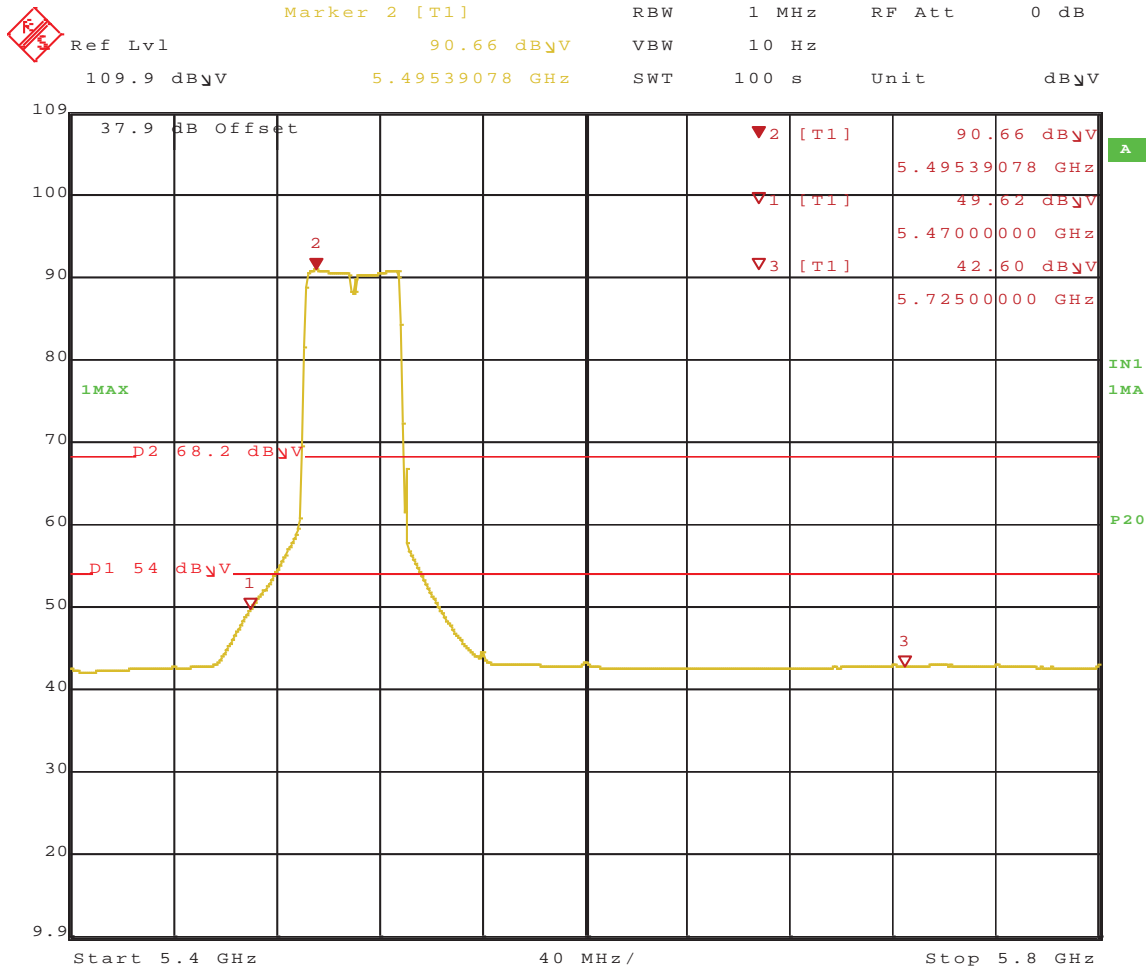

Date: 15.MAR.2011 09:54:44

Figure 632: Radiated Emission at the Edge for Channel 5510 MHz at 13.5Mbps – Vert. (Ave.)

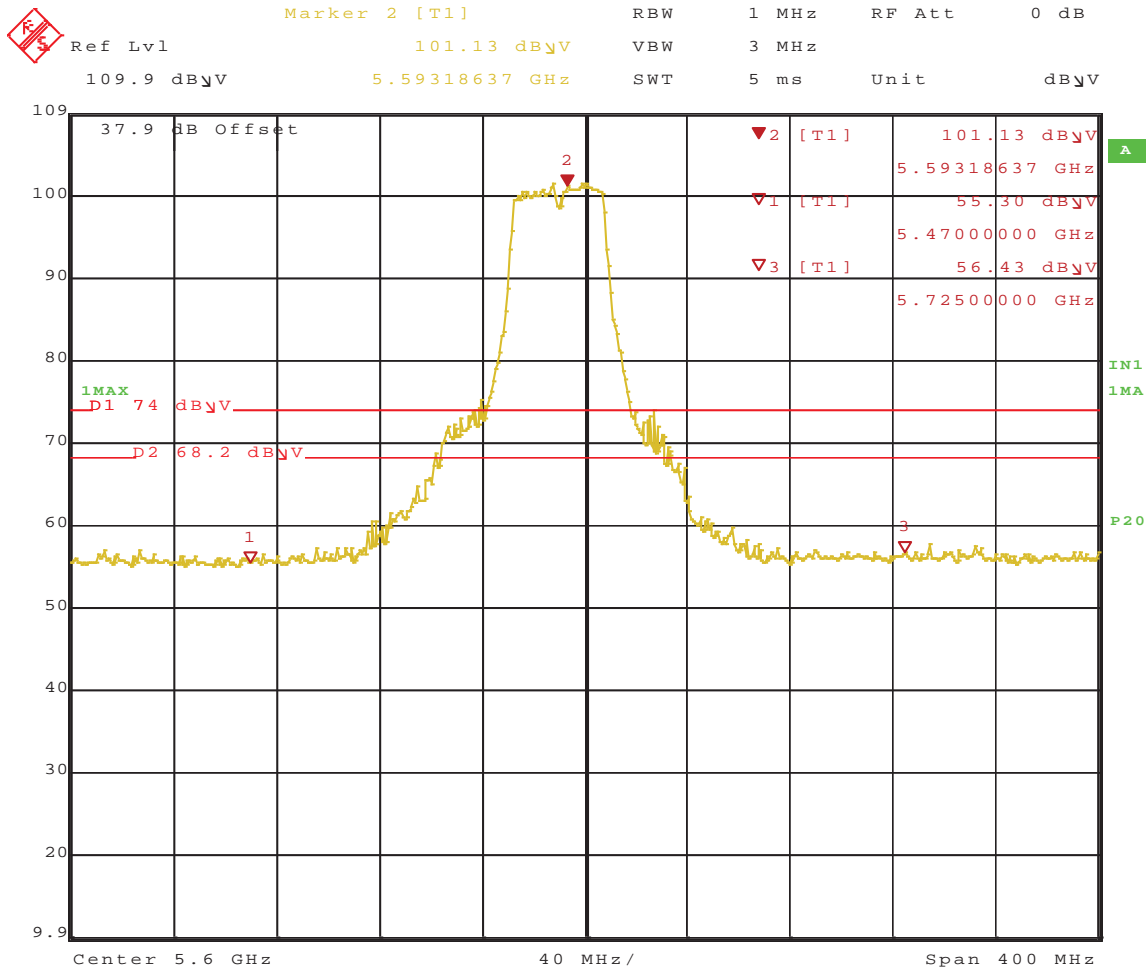

Date: 15.MAR.2011 10:04:10

Figure 633: Radiated Emission at the Edge for Channel 5590 MHz at 13.5Mbps – Horiz. (Peak)

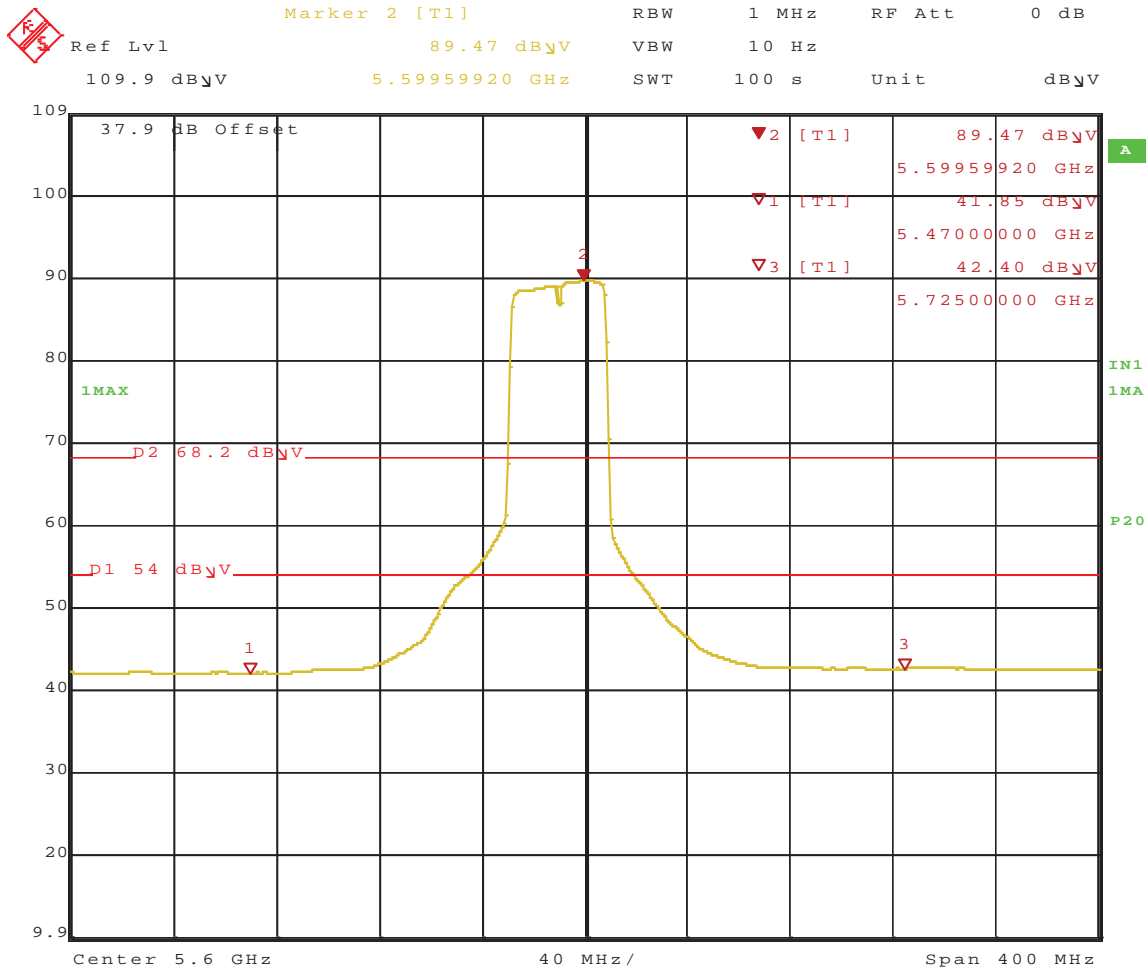

Date: 15.MAR.2011 10:06:18

Figure 634: Radiated Emission at the Edge for Channel 5590 MHz at 13.5Mbps – Horz. (Ave.)

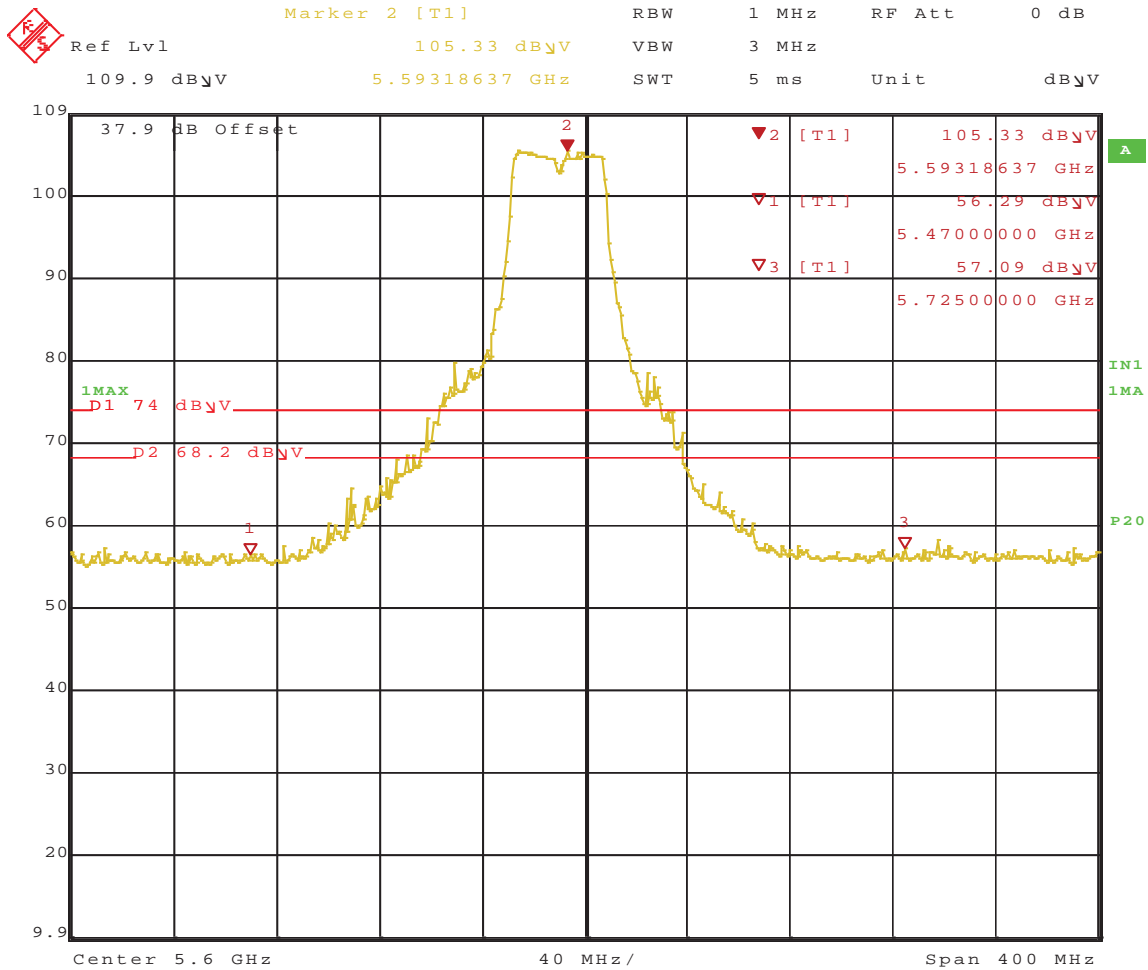

Date: 15.MAR.2011 09:58:47

Figure 635: Radiated Emission at the Edge for Channel 5590 MHz at 13.5Mbps – Vert. (Peak)

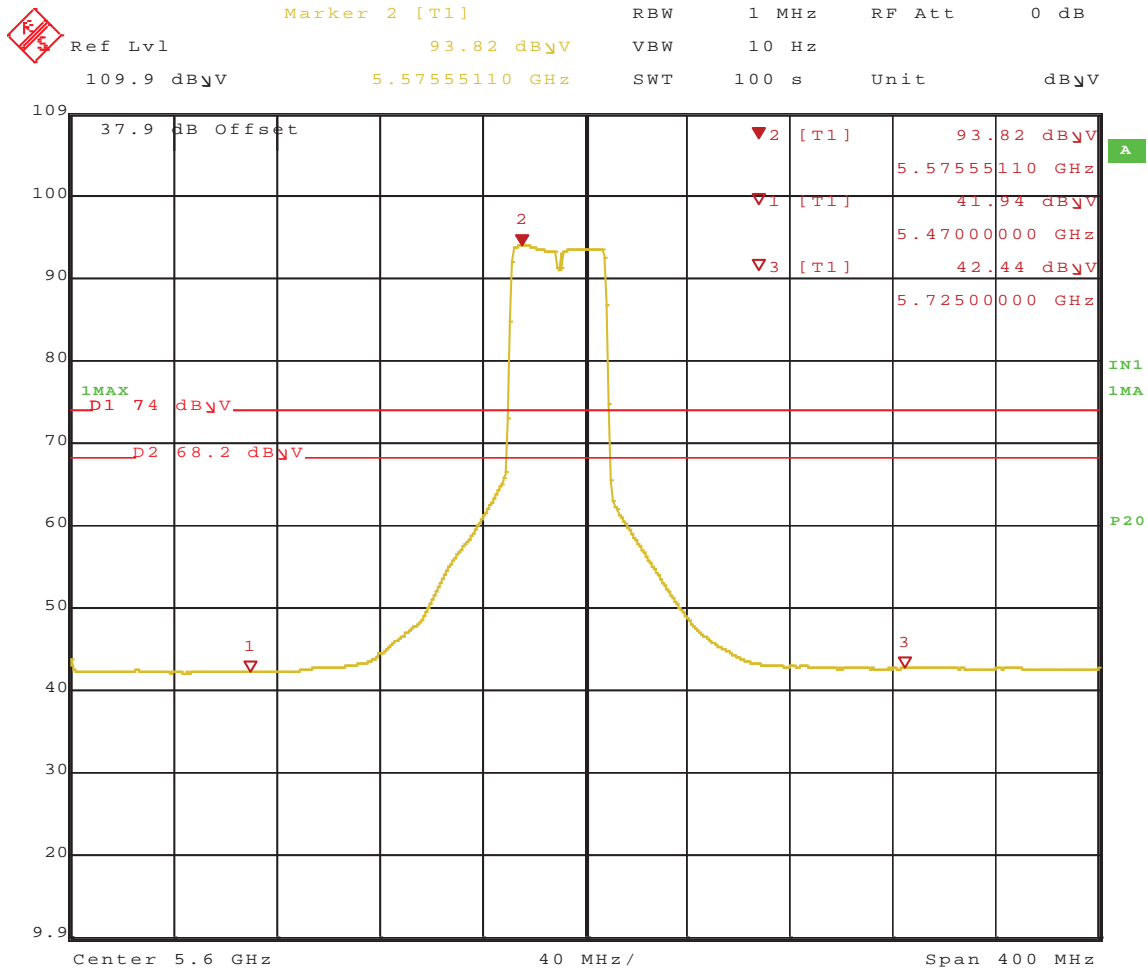

Date: 15.MAR.2011 10:00:56

Figure 636: Radiated Emission at the Edge for Channel 5590 MHz at 13.5Mbps – Vert. (Ave.)

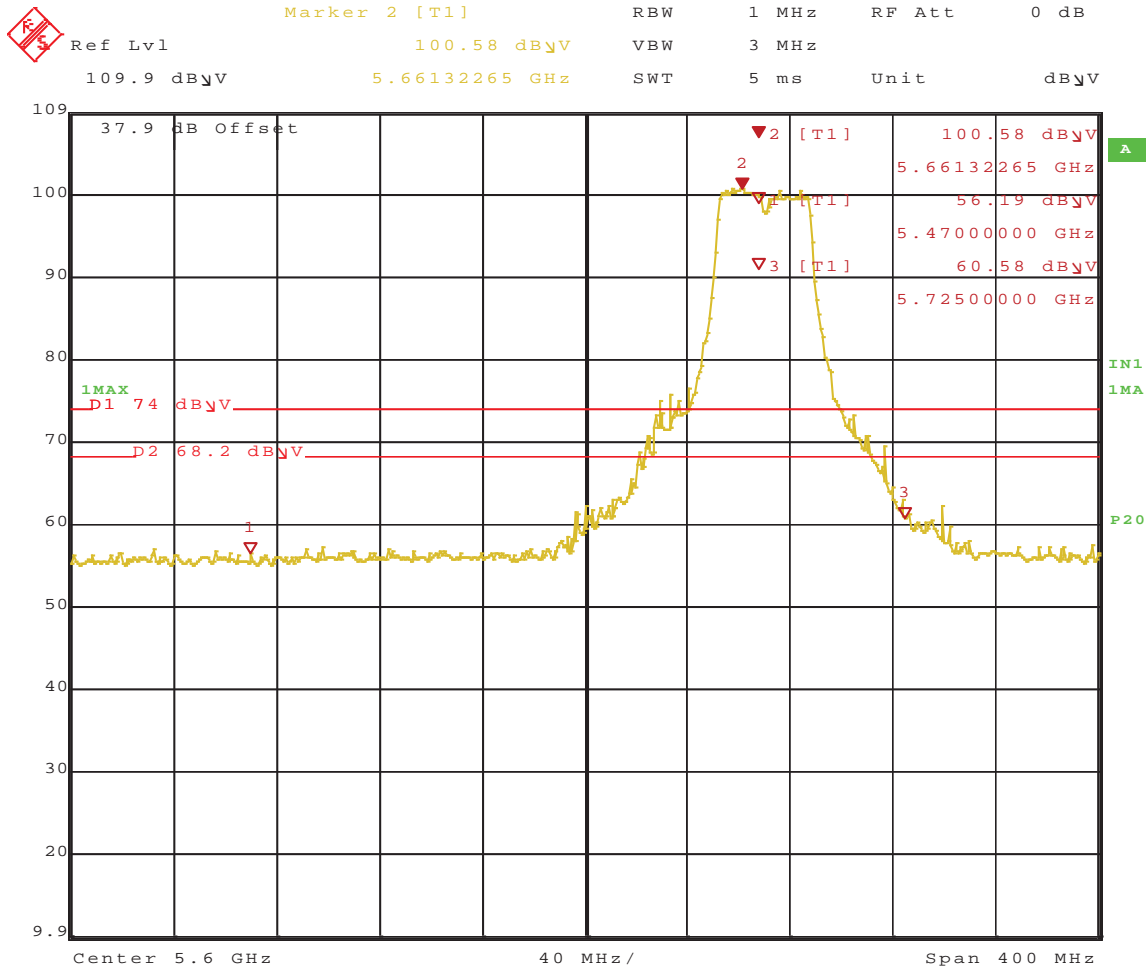

Date: 15.MAR.2011 10:10:23

Figure 637: Radiated Emission at the Edge for 5670 MHz at 13.5Mbps – Horz. (Peak)

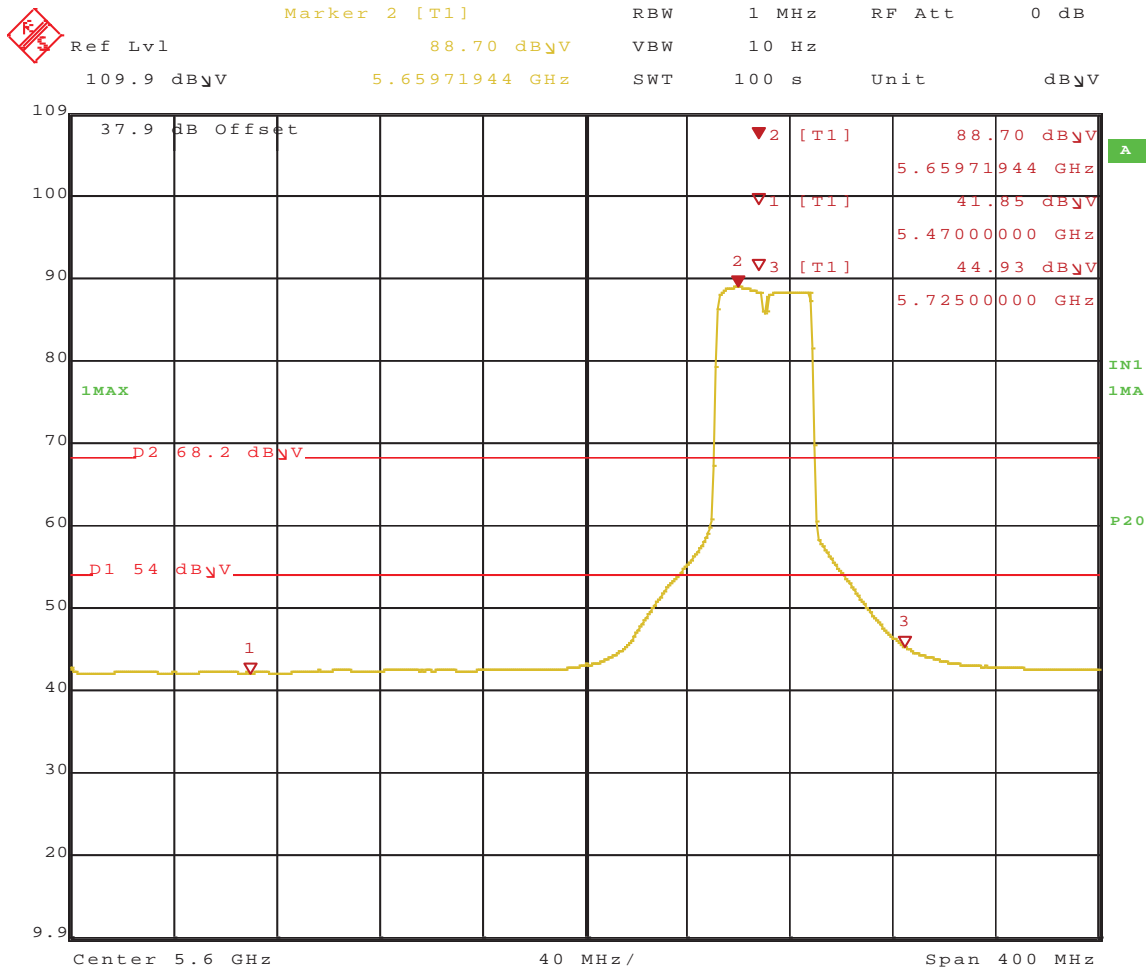

Date: 15.MAR.2011 10:12:49

Figure 638: Radiated Emission at the Edge for 5670 MHz at 13.5Mbps – Horz. (Ave.)

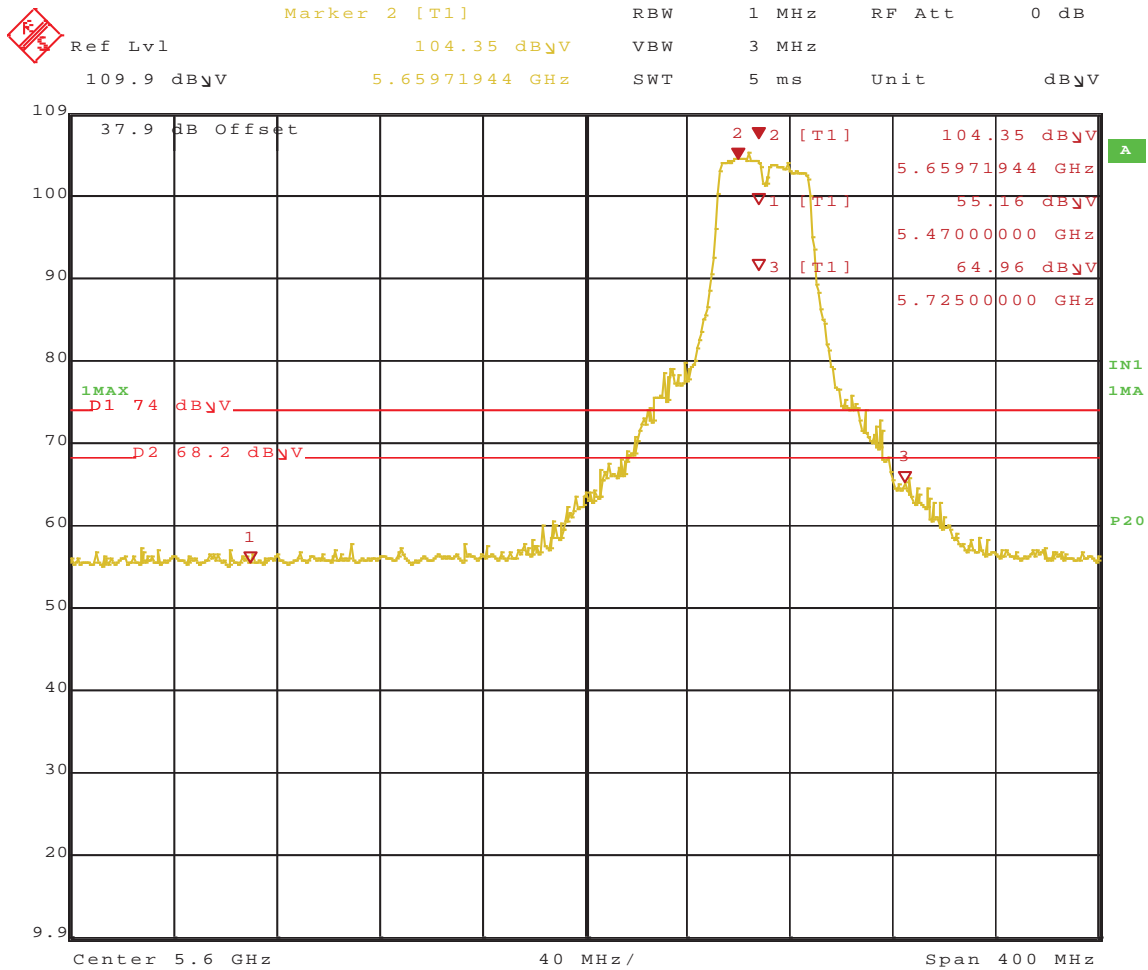

Date: 15.MAR.2011 10:15:40

Figure 639: Radiated Emission at the Edge for 5670 MHz at 13.5Mbps – Vert. (Peak)

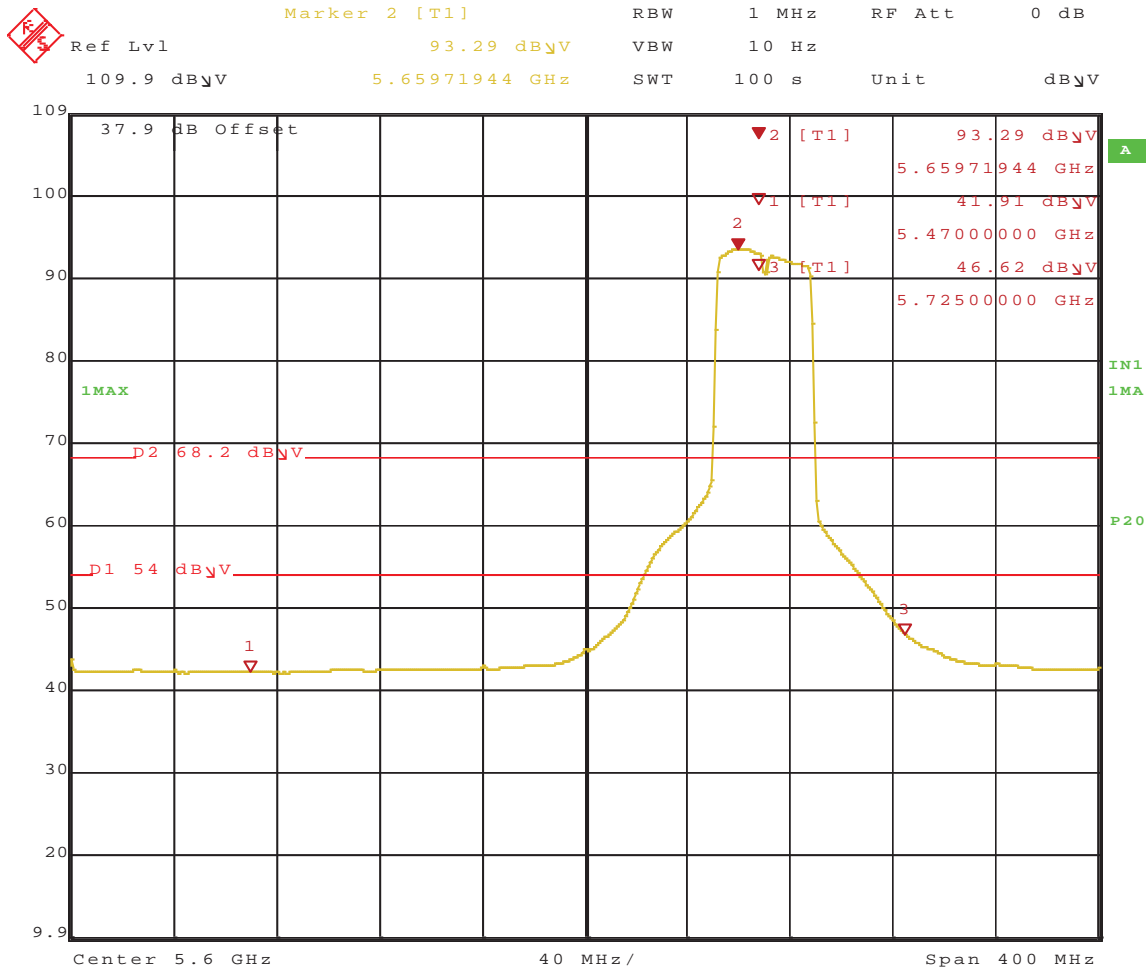

Date: 15.MAR.2011 10:17:49

Figure 640: Radiated Emission at the Edge for 5670 MHz at 13.5Mbps – Vert. (Ave.)

SOP 1 Radiated Emissions											Tracking # 31053887.002 Page 1 of 2	
EUT Name		OPTIVIEW XG, OPVXG, OPTIVIEW XG-10G, OPVXG-10G, OPVXGPRO, OPVXG-EXPT, OPTIVIEW XG-LAN, OPVXG-LAN, OPVXG-LAN-10G, OPTIVIEW XG WLAN, OPVXG-WLAN					Date		March 18, 2011			
EUT Model		3365336, 3949539, 3949542, 3949556, 3949616, 4020634					Temp / Hum in		21°C / 38%rh			
EUT Serial		Prototype					Temp / Hum out		N/A			
EUT Config.		Y-Axis, 802.11a at 6Mbps					Line AC / Freq		120Vac/60Hz			
Standard		CFR47 Part 15 Subpart C					RBW / VBW		120 kHz/ 300 kHz			
Dist/Ant Used		3m / JB3					Performed by		Jeremy Luong			
Emission Freq (MHz)	ANT Polar (H/V)	ANT Pos (cm)	Table Pos (deg)	FIM (Pk) (dBuV/m)	FIM Ave (dBuV/m)	Total CF (dBuV)	E-Field Ave (dBuV/m)	Spec Limit (dBuV/m)	Spec Margin (dB)	Type		
30 MHz to 1GHz Transmitted at 802.11a, 5300 MHz 6Mbps												
85.41	H	263	163	66.65	65.01	-18.43	46.58	49.54	-2.96	Spurious		
86.21	H	299	150	66.56	64.77	-18.46	46.31	49.54	-3.23	Spurious		
500.04	H	155	99	47.12	46.18	-7.17	39.01	56.90	-17.89	Spurious		
625.03	H	120	131	44.42	43.14	-5.29	37.85	56.90	-19.05	Spurious		
719.99	H	107	334	43.34	42.18	-3.56	38.62	56.90	-18.28	Spurious		
750.05	H	105	164	43.39	42.98	-3.18	39.80	56.90	-17.10	Spurious		
871.48	H	142	272	46.39	45.88	-1.45	44.43	56.90	-12.47	Spurious		
874.27	H	148	249	48.01	46.78	-1.45	45.33	56.90	-11.57	Spurious		
85.43	V	126	190	60.98	59.57	-18.44	41.13	49.54	-8.41	Spurious		
85.54	V	163	185	60.95	59.75	-18.42	41.33	49.54	-8.21	Spurious		
500.03	V	106	331	48.97	47.70	-7.57	40.13	56.90	-16.77	Spurious		
871.49	V	106	298	47.40	46.85	-1.99	44.86	56.90	-12.04	Spurious		
874.38	V	107	305	48.77	46.85	-1.87	44.98	56.90	-11.92	Spurious		
Spec Margin = E-Field QP - Limit, E-Field QP = FIM QP+ Total CF ± Uncertainty												
Total CF= Amp Gain + Cable Loss + ANT Factor												
Combined Standard Uncertainty $u_c(y) = \pm 3.2$ dB Expanded Uncertainty $U = k u_c(y)$ $k = 2$ for 95% confidence												
Notes: Worst case was observed on Y-axis at 802.11a, 5300 MHz 6Mbps.												
Emissions at 85MHz are broadband emission. It emitted from OptiView power source, and it is not related to the radio module. The OptiView XG is marketed as Class A Device.												
All other emissions passed Class B limit.												

SOP 1 Radiated Emissions

Tracking # 31053887.002 Page 2 of 2

EUT Name	OPTIVIEW XG, OPVXG, OPTIVIEW XG-10G, OPVXG-10G, OPVXGPRO, OPVXG-EXPT, OPTIVIEW XG-LAN, OPVXG-LAN, OPVXG-LAN-10G, OPTIVIEW XG WLAN, OPVXG-WLAN	Date	March 18, 2011
EUT Model	3365336, 3949539, 3949542, 3949556, 3949616, 4020634	Temp / Hum in	21°C / 38%rh
EUT Serial	Prototype	Temp / Hum out	N/A
EUT Config.	Y-Axis, 802.11a at 6Mbps	Line AC	120Vac 60Hz
Standard	CFR47 Part 15 Subpart C	RBW / VBW	120 kHz / 300 kHz
Dist/Ant Used	3m – JB3	Performed by	Jeremy Luong

30 MHz to 1GHz Plots for Transmit Mode at 5300 MHz

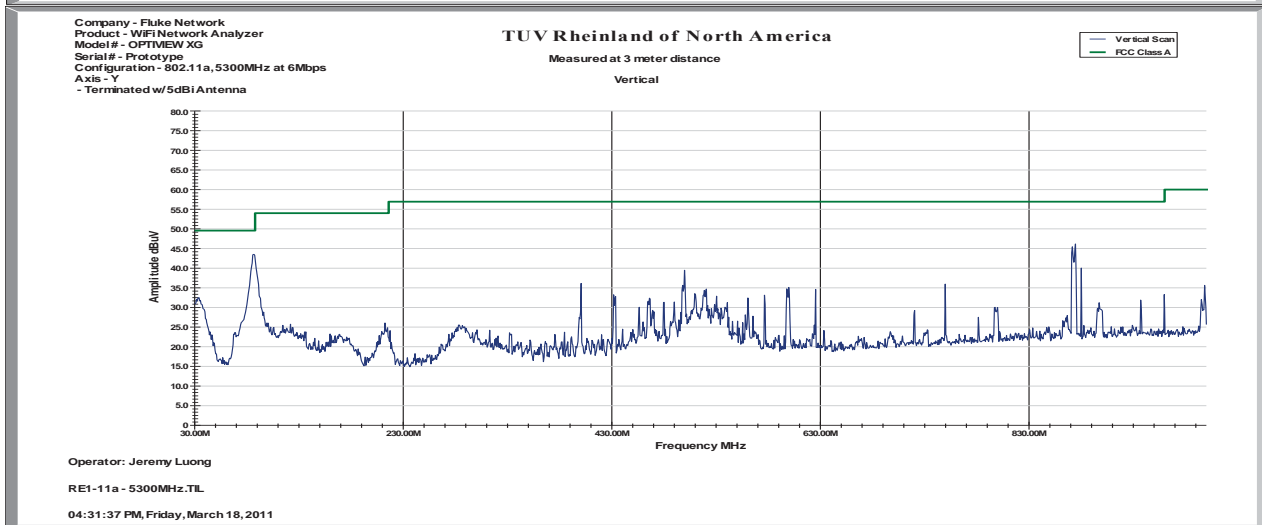
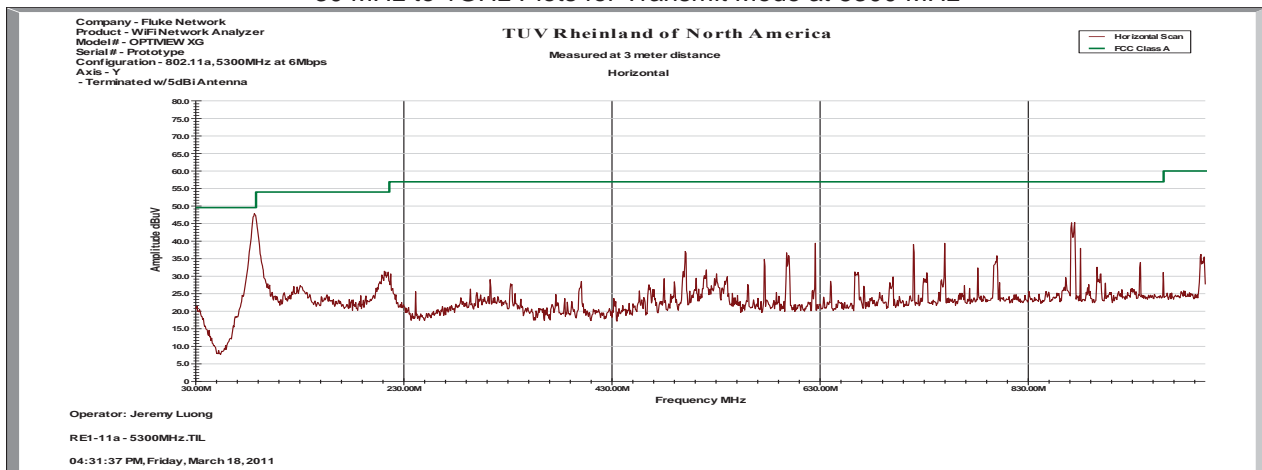

Notes: FCC Class A Limit.

SOP 1 Radiated Emissions											Tracking # 31053887.002 Page 1 of 21	
EUT Name		OPTIVIEW XG, OPVXG, OPTIVIEW XG-10G, OPVXG-10G, OPVXGPRO, OPVXG-EXPT, OPTIVIEW XG-LAN, OPVXG-LAN, OPVXG-LAN-10G, OPTIVIEW XG WLAN, OPVXG-WLAN						Date		February 10, 2011		
EUT Model		3365336, 3949539, 3949542, 3949556, 3949616, 4020634						Temp / Hum in		23°C / 33%rh		
EUT Serial		Prototype						Temp / Hum out		N/A		
EUT Config.		Y-Axis, 802.11a at 6Mbps						Line AC / Freq		120Vac/60Hz		
Standard		CFR47 Part 15 Subpart C						RBW / VBW		1 MHz/ 3 MHz		
Dist/Ant Used		3m / EMCO3115 / 1m - RA42-K-F-4B-C						Performed by		Jeremy Luong		
Emission Freq (MHz)	ANT Polar (H/V)	ANT Pos (cm)	Table Pos (deg)	FIM (Pk) (dBuV/m)	FIM Ave (dBuV/m)	Total CF (dBuV)	E-Field Ave (dBuV/m)	Spec Limit (dBuV/m)	Spec Margin (dB)	Type		
Transmitted Data at 5180 MHz @ 11 dBm												
1120.19	H	114	42	63.28	51.60	-8.62	42.98	53.98	-11.00	Spurious		
1596.64	H	130	255	63.01	41.15	-6.82	34.33	53.98	-19.65	Spurious		
1861.03	H	133	230	60.53	46.22	-4.94	41.28	53.98	-12.70	Spurious		
2392.91	H	133	154	54.07	34.57	-3.00	31.57	53.98	-22.41	Spurious		
5000.08	V	150	459	46.80	40.51	2.84	43.35	53.98	-10.63	Spurious		
Transmitted Data at 5220 MHz @ 11 dBm												
1120.14	H	203	405	61.89	50.68	-8.62	42.06	53.98	-11.92	Spurious		
1120.24	V	218	435	60.76	46.21	-8.62	37.59	53.98	-16.39	Spurious		
1861.09	H	96	218	60.20	46.29	-4.94	41.35	53.98	-12.63	Spurious		
2490.58	H	193	-73	53.21	33.20	-2.68	30.52	53.98	-23.46	Spurious		
4840.03	V	217	105	49.69	43.39	2.50	45.89	53.98	-8.09	Spurious		
Transmitted Data at 5240 MHz @ 11 dBm												
1120.19	H	116	418	60.62	50.52	-8.62	41.90	53.98	-12.08	Spurious		
1861.15	H	129	261	60.81	46.10	-4.94	41.16	53.98	-12.82	Spurious		
2392.12	H	115	194	56.63	35.77	-3.01	32.76	53.98	-21.22	Spurious		
10480.20	V	129	226	33.06	19.65	11.82	31.46	53.98	-22.52	Harmonic		
10480.20	H	99	343	34.13	20.08	11.82	31.90	53.98	-22.08	Harmonic		
Spec Margin = E-Field QP - Limit, E-Field QP = FIM QP+ Total CF ± Uncertainty												
Total CF= Amp Gain + Cable Loss + ANT Factor												
Combined Standard Uncertainty $u_c(y) = \pm 3.2$ dB Expanded Uncertainty $U = ku_c(y)$ $k = 2$ for 95% confidence												
Notes: Worst case was observed on Y-axis, 6Mbps.												

SOP 1 Radiated Emissions											Tracking # 31053887.002 Page 2 of 21	
EUT Name		OPTIVIEW XG, OPVXG, OPTIVIEW XG-10G, OPVXG-10G, OPVXGPRO, OPVXG-EXPT, OPTIVIEW XG-LAN, OPVXG-LAN, OPVXG-LAN-10G, OPTIVIEW XG WLAN, OPVXG-WLAN					Date		February 10, 2011			
EUT Model		3365336, 3949539, 3949542, 3949556, 3949616, 4020634					Temp / Hum in		23°C / 33%rh			
EUT Serial		Prototype					Temp / Hum out		N/A			
EUT Config.		Y-Axis, 802.11a at 6Mbps					Line AC / Freq		120Vac/60Hz			
Standard		CFR47 Part 15 Subpart C					RBW / VBW		1 MHz/ 3 MHz			
Dist/Ant Used		3m / EMCO3115 / 1m - RA42-K-F-4B-C					Performed by		Jeremy Luong			
Emission Freq (MHz)	ANT Polar (H/V)	ANT Pos (cm)	Table Pos (deg)	FIM (Pk) (dBuV/m)	FIM Ave (dBuV/m)	Total CF (dBuV)	E-Field Ave (dBuV/m)	Spec Limit (dBuV/m)	Spec Margin (dB)	Type		
Transmitted Data at 5260 MHz @ 16 dBm												
1120.18	H	108	346	60.01	49.36	-8.62	40.74	53.98	-13.24	Spurious		
1861.15	H	134	218	59.74	46.39	-4.94	41.45	53.98	-12.53	Spurious		
2392.88	H	161	163	55.73	35.65	-3.00	32.65	53.98	-21.33	Spurious		
4840.03	V	161	156	48.65	44.05	2.50	46.55	53.98	-7.43	Spurious		
10519.5	H	171	431	36.85	24.88	11.83	36.71	53.98	-17.27	Harmonic		
10522.5	V	155	62	36.06	23.83	11.83	35.66	53.98	-18.32	Harmonic		
Transmitted Data at 5300 MHz @ 16 dBm												
1120.17	H	117	410	62.97	51.32	-8.62	42.70	53.98	-11.28	Spurious		
1494.89	H	165	169	60.19	40.27	-7.69	32.58	53.98	-21.40	Spurious		
1861.15	H	165	260	56.84	43.33	-4.94	38.39	53.98	-15.59	Spurious		
2392.00	H	121	199	56.23	36.23	-3.01	33.22	53.98	-20.76	Spurious		
4840.04	V	196	463	48.99	43.58	2.50	46.08	53.98	-7.90	Spurious		
10599.20	V	192	185	31.49	23.25	11.78	35.04	53.98	-18.94	Harmonic		
10601.70	H	118	-20	34.04	20.78	11.78	32.56	53.98	-21.42	Harmonic		
Transmitted Data at 5320 MHz @ 14 dBm												
1120.19	H	114	43	62.58	51.33	-8.62	42.71	53.98	-11.27	Spurious		
1861.15	H	127	257	59.13	45.50	-4.94	40.56	53.98	-13.42	Spurious		
2392.29	H	199	203	56.75	35.58	-3.01	32.57	53.98	-21.41	Spurious		
4840.06	V	218	111	49.71	44.02	2.50	46.52	53.98	-7.46	Spurious		
Spec Margin = E-Field QP - Limit, E-Field QP = FIM QP+ Total CF ± Uncertainty												
Total CF= Amp Gain + Cable Loss + ANT Factor												
Combined Standard Uncertainty $u_c(y) = \pm 3.2$ dB Expanded Uncertainty $U = k u_c(y)$ $k = 2$ for 95% confidence												
Notes: Worst case was observed on Y-axis, 6Mbps.												

SOP 1 Radiated Emissions											Tracking # 31053887.002 Page 3 of 21	
EUT Name		OPTIVIEW XG, OPVXG, OPTIVIEW XG-10G, OPVXG-10G, OPVXGPRO, OPVXG-EXPT, OPTIVIEW XG-LAN, OPVXG-LAN, OPVXG-LAN-10G, OPTIVIEW XG WLAN, OPVXG-WLAN					Date		February 10, 2011			
EUT Model		3365336, 3949539, 3949542, 3949556, 3949616, 4020634					Temp / Hum in		23°C / 33%rh			
EUT Serial		Prototype					Temp / Hum out		N/A			
EUT Config.		Y-Axis, 802.11a at 6Mbps					Line AC / Freq		120Vac/60Hz			
Standard		CFR47 Part 15 Subpart C					RBW / VBW		1 MHz/ 3 MHz			
Dist/Ant Used		3m / EMCO3115 / 1m - RA42-K-F-4B-C					Performed by		Jeremy Luong			
Emission Freq (MHz)	ANT Polar (H/V)	ANT Pos (cm)	Table Pos (deg)	FIM (Pk) (dBuV/m)	FIM Ave (dBuV/m)	Total CF (dBuV)	E-Field Ave (dBuV/m)	Spec Limit (dBuV/m)	Spec Margin (dB)	Type		
Transmitted Data at 5500 MHz @ 14 dBm												
1120.01	H	115	45	61.47	50.55	-8.62	41.93	53.98	-12.05	Spurious		
1861.15	H	129	258	57.35	45.34	-4.94	40.40	53.98	-13.58	Spurious		
2392.47	H	157	201	57.34	36.06	-3.01	33.05	53.98	-20.93	Spurious		
5000.06	V	157	166	48.35	42.69	2.84	45.53	53.98	-8.45	Spurious		
Transmitted Data at 5600 MHz @ 14 dBm												
1120.16	H	119	46	63.27	51.44	-8.62	42.82	53.98	-11.16	Spurious		
1120.25	V	205	447	60.41	45.68	-8.62	37.06	53.98	-16.92	Spurious		
1861.17	H	129	258	58.63	45.21	-4.94	40.27	53.98	-13.71	Spurious		
2392.90	H	119	204	57.73	36.33	-3.00	33.33	53.98	-20.65	Spurious		
4840.01	V	198	114	49.28	43.59	2.50	46.09	53.98	-7.89	Spurious		
5000.06	V	194	226	48.05	41.82	2.84	44.66	53.98	-9.32	Spurious		
11200.90	H	140	466	35.20	22.98	12.38	35.36	53.98	-18.62	Harmonic		
11200.90	V	155	168	35.87	23.51	12.38	35.89	53.98	-18.09	Harmonic		
Transmitted Data at 5700 MHz @ 13dBm												
1120.18	H	209	399	61.68	50.31	-8.62	41.69	53.98	-12.29	Spurious		
1120.25	V	198	90	59.17	45.36	-8.62	36.74	53.98	-17.24	Spurious		
1861.03	H	201	137	56.31	42.69	-4.94	37.75	53.98	-16.23	Spurious		
2392.10	H	115	198	57.10	36.30	-3.01	33.29	53.98	-20.69	Spurious		
4840.07	V	201	171	49.56	44.67	2.50	47.17	53.98	-6.81	Spurious		
5000.06	V	166	459	48.12	42.23	2.84	45.07	53.98	-8.91	Spurious		
11400.10	V	107	188	44.24	29.05	12.73	41.77	53.98	-12.21	Harmonic		
11400.90	H	111	134	40.20	26.64	12.73	39.37	53.98	-14.61	Harmonic		
Spec Margin = E-Field QP - Limit, E-Field QP = FIM QP+ Total CF ± Uncertainty												
Total CF= Amp Gain + Cable Loss + ANT Factor												
Combined Standard Uncertainty $u_c(y) = \pm 3.2$ dB Expanded Uncertainty $U = k u_c(y)$ $k = 2$ for 95% confidence												
Notes: Worst case was observed on Y-axis, 6Mbps.												

SOP 1 Radiated Emissions

Tracking # 31053887.002 Page 4 of 21

EUT Name	OPTIVIEW XG, OPVXG, OPTIVIEW XG-10G, OPVXG-10G, OPVXGPRO, OPVXG-EXPT, OPTIVIEW XG-LAN, OPVXG-LAN, OPVXG-LAN-10G, OPTIVIEW XG WLAN, OPVXG-WLAN	Date	March 17, 2011
EUT Model	3365336, 3949539, 3949542, 3949556, 3949616, 4020634	Temp / Hum in	23°C / 39%rh
EUT Serial	Prototype	Temp / Hum out	N/A
EUT Config.	Y-Axis, 802.11a at 6Mbps	Line AC	120Vac 60Hz
Standard	CFR47 Part 15 Subpart C	RBW / VBW	1 MHz / 3MHz
Dist/Ant Used	3m - EMCO3115 / 1m - RA42-K-F-4B-C	Performed by	Jeremy Luong

Above 1GHz Plots for Transmit Mode at 5180 MHz

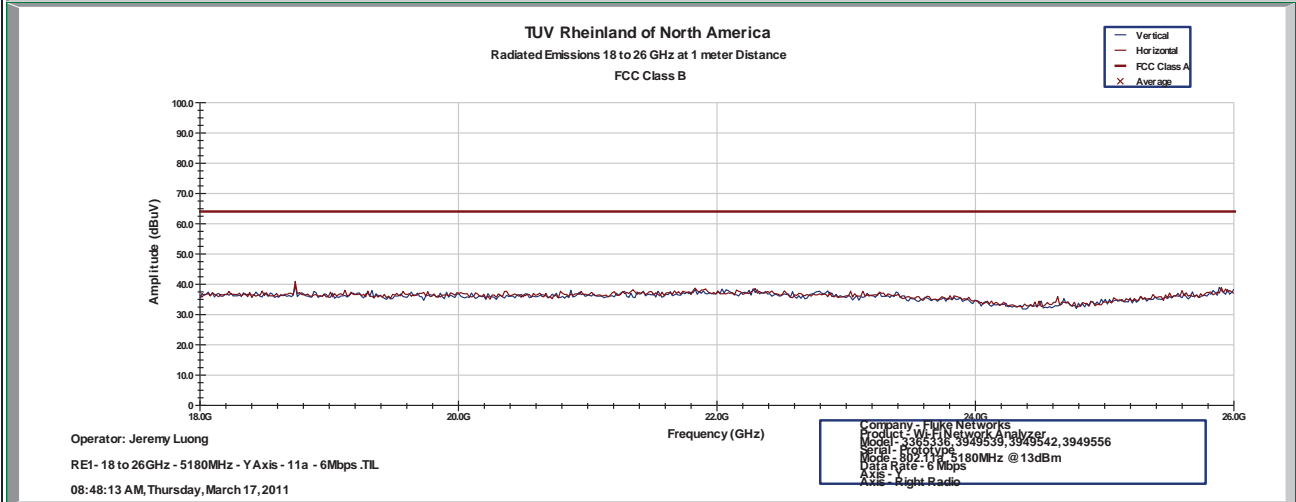
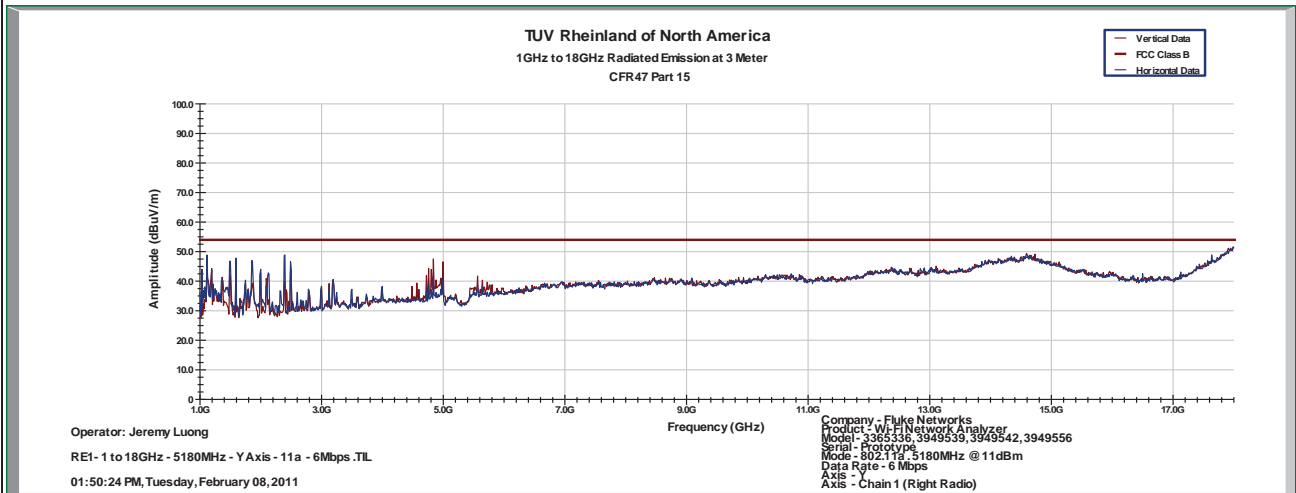

Notes: Limit was extrapolated to 1m distance for 18GHz – 40 GHz range.

SOP 1 Radiated Emissions

Tracking # 31053887.002 Page 5 of 21

EUT Name	OPTIVIEW XG, OPVXG, OPTIVIEW XG-10G, OPVXG-10G, OPVXGPRO, OPVXG-EXPT, OPTIVIEW XG-LAN, OPVXG-LAN, OPVXG-LAN-10G, OPTIVIEW XG WLAN, OPVXG-WLAN	Date	March 17, 2011
EUT Model	3365336, 3949539, 3949542, 3949556, 3949616, 4020634	Temp / Hum in	23°C / 39%rh
EUT Serial	Prototype	Temp / Hum out	N/A
EUT Config.	Y-Axis, 802.11a at 6Mbps	Line AC	120Vac 60Hz
Standard	CFR47 Part 15 Subpart C	RBW / VBW	1 MHz / 3MHz
Dist/Ant Used	1m - RA42-K-F-4B-C	Performed by	Jeremy Luong

Above 1GHz Plots for Transmit Mode at 5180 MHz

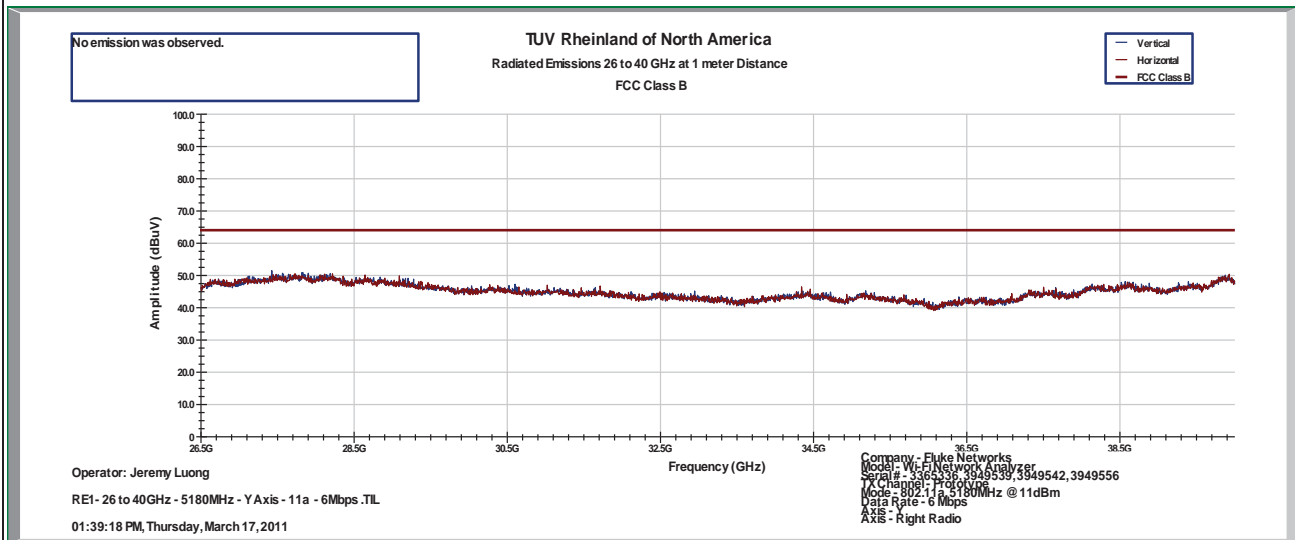

Notes: Limit was extrapolated to 1m distance for 18GHz – 40 GHz range.

SOP 1 Radiated Emissions

Tracking # 31053887.002 Page 6 of 21

EUT Name	OPTIVIEW XG, OPVXG, OPTIVIEW XG-10G, OPVXG-10G, OPVXGPRO, OPVXG-EXPT, OPTIVIEW XG-LAN, OPVXG-LAN, OPVXG-LAN-10G, OPTIVIEW XG WLAN, OPVXG-WLAN	Date	March 17, 2011
EUT Model	3365336, 3949539, 3949542, 3949556, 3949616, 4020634	Temp / Hum in	23°C / 39%rh
EUT Serial	Prototype	Temp / Hum out	N/A
EUT Config.	Y-Axis, 802.11a at 6Mbps	Line AC	120Vac 60Hz
Standard	CFR47 Part 15 Subpart C	RBW / VBW	1 MHz / 3MHz
Dist/Ant Used	3m - EMCO3115 / 1m - RA42-K-F-4B-C	Performed by	Jeremy Luong

Above 1GHz Plots for Transmit Mode at 5220 MHz

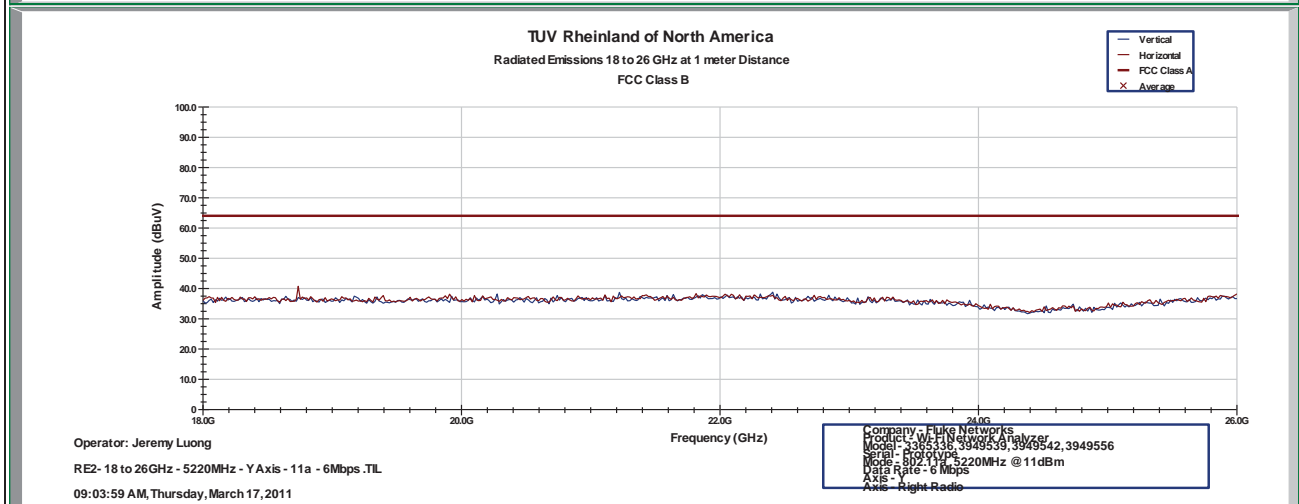
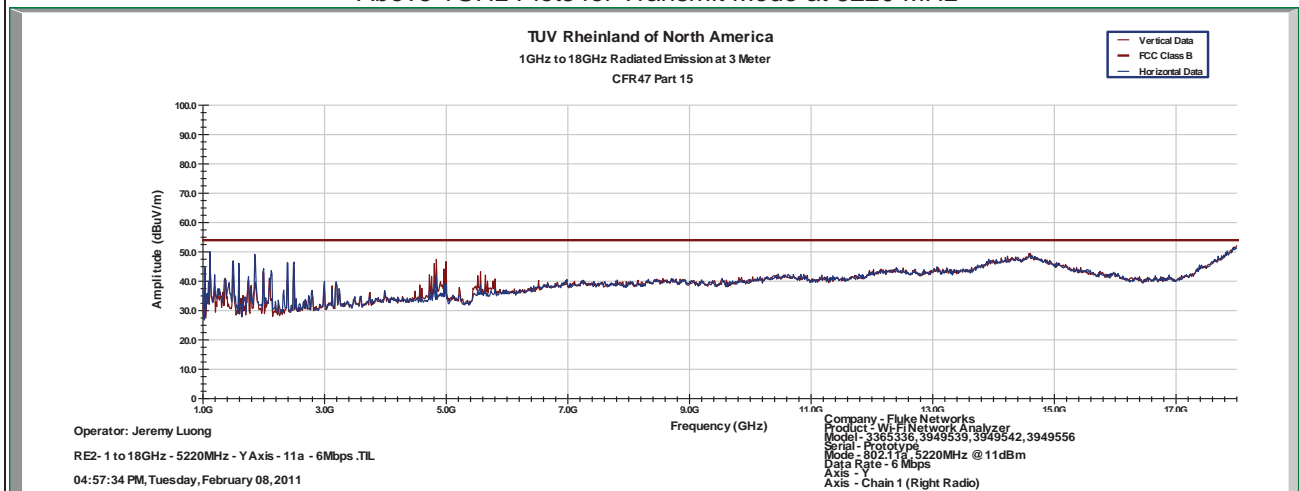

Notes: Limit was extrapolated to 1m distance for 18GHz – 40 GHz range.

SOP 1 Radiated Emissions

Tracking # 31053887.002 Page 7 of 21

EUT Name	OPTIVIEW XG, OPVXG, OPTIVIEW XG-10G, OPVXG-10G, OPVXGPRO, OPVXG-EXPT, OPTIVIEW XG-LAN, OPVXG-LAN, OPVXG-LAN-10G, OPTIVIEW XG WLAN, OPVXG-WLAN	Date	March 17, 2011
EUT Model	3365336, 3949539, 3949542, 3949556, 3949616, 4020634	Temp / Hum in	23°C / 39%rh
EUT Serial	Prototype	Temp / Hum out	N/A
EUT Config.	Y-Axis, 802.11a at 6Mbps	Line AC	120Vac 60Hz
Standard	CFR47 Part 15 Subpart C	RBW / VBW	1 MHz / 3MHz
Dist/Ant Used	1m - RA42-K-F-4B-C	Performed by	Jeremy Luong

Above 1GHz Plots for Transmit Mode at 5220 MHz

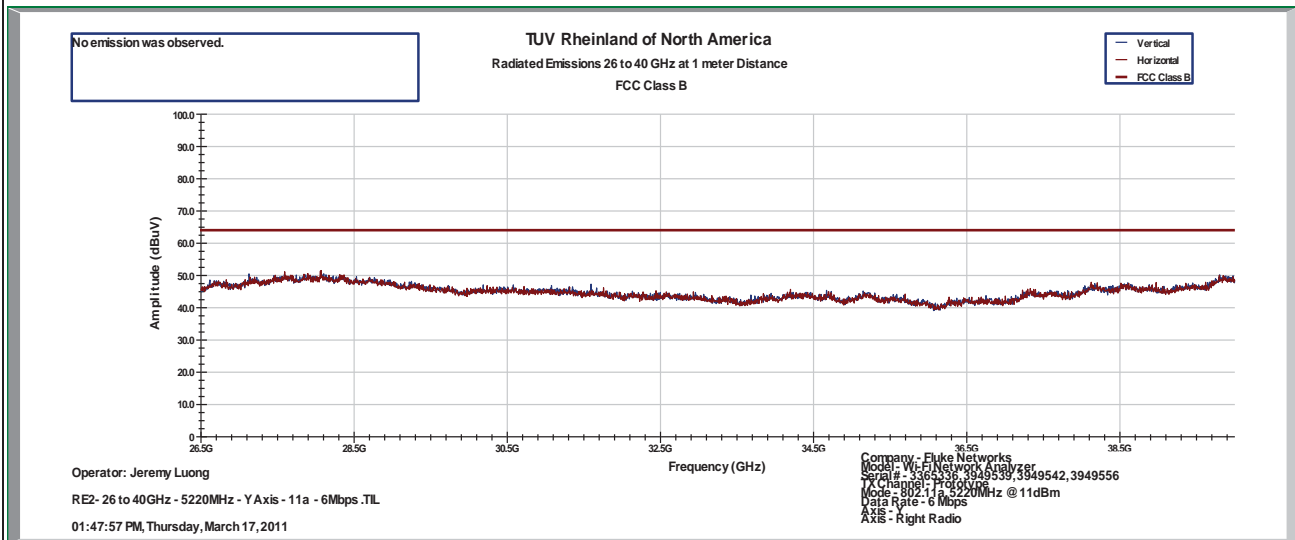

Notes: Limit was extrapolated to 1m distance for 18GHz – 40 GHz range.

SOP 1 Radiated Emissions

Tracking # 31053887.002 Page 8 of 21

EUT Name	OPTIVIEW XG, OPVXG, OPTIVIEW XG-10G, OPVXG-10G, OPVXGPRO, OPVXG-EXPT, OPTIVIEW XG-LAN, OPVXG-LAN, OPVXG-LAN-10G, OPTIVIEW XG WLAN, OPVXG-WLAN	Date	March 17, 2011
EUT Model	3365336, 3949539, 3949542, 3949556, 3949616, 4020634	Temp / Hum in	23°C / 39%rh
EUT Serial	Prototype	Temp / Hum out	N/A
EUT Config.	Y-Axis, 802.11a at 6Mbps	Line AC	120Vac 60Hz
Standard	CFR47 Part 15 Subpart C	RBW / VBW	1 MHz / 3MHz
Dist/Ant Used	3m - EMCO3115 / 1m - RA42-K-F-4B-C	Performed by	Jeremy Luong

Above 1GHz Plots for Transmit Mode at 5240 MHz

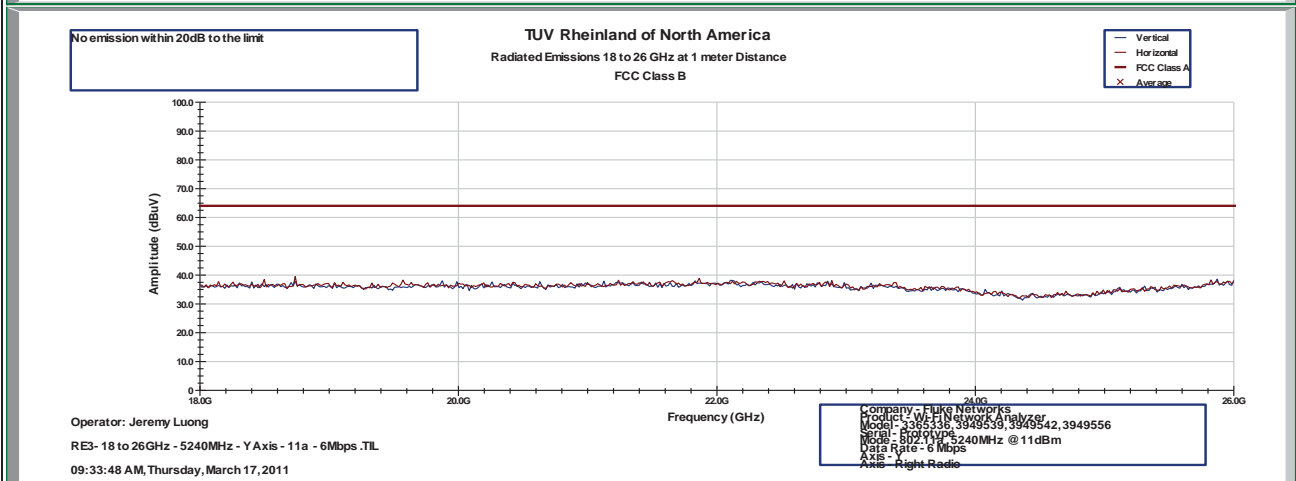
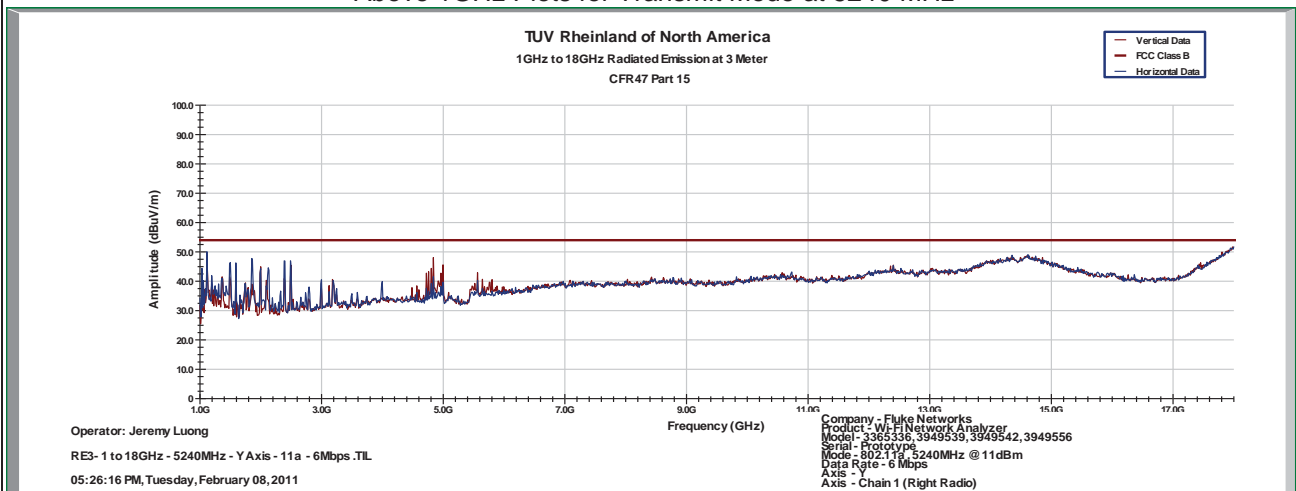

Notes: Limit was extrapolated to 1m distance for 18GHz – 40 GHz range.

SOP 1 Radiated Emissions

Tracking # 31053887.002 Page 9 of 21

EUT Name	OPTIVIEW XG, OPVXG, OPTIVIEW XG-10G, OPVXG-10G, OPVXGPRO, OPVXG-EXPT, OPTIVIEW XG-LAN, OPVXG-LAN, OPVXG-LAN-10G, OPTIVIEW XG WLAN, OPVXG-WLAN	Date	March 17, 2011
EUT Model	3365336, 3949539, 3949542, 3949556, 3949616, 4020634	Temp / Hum in	23°C / 39%rh
EUT Serial	Prototype	Temp / Hum out	N/A
EUT Config.	Y-Axis, 802.11a at 6Mbps	Line AC	120Vac 60Hz
Standard	CFR47 Part 15 Subpart C	RBW / VBW	1 MHz / 3MHz
Dist/Ant Used	1m - RA42-K-F-4B-C	Performed by	Jeremy Luong

Above 1GHz Plots for Transmit Mode at 5240 MHz

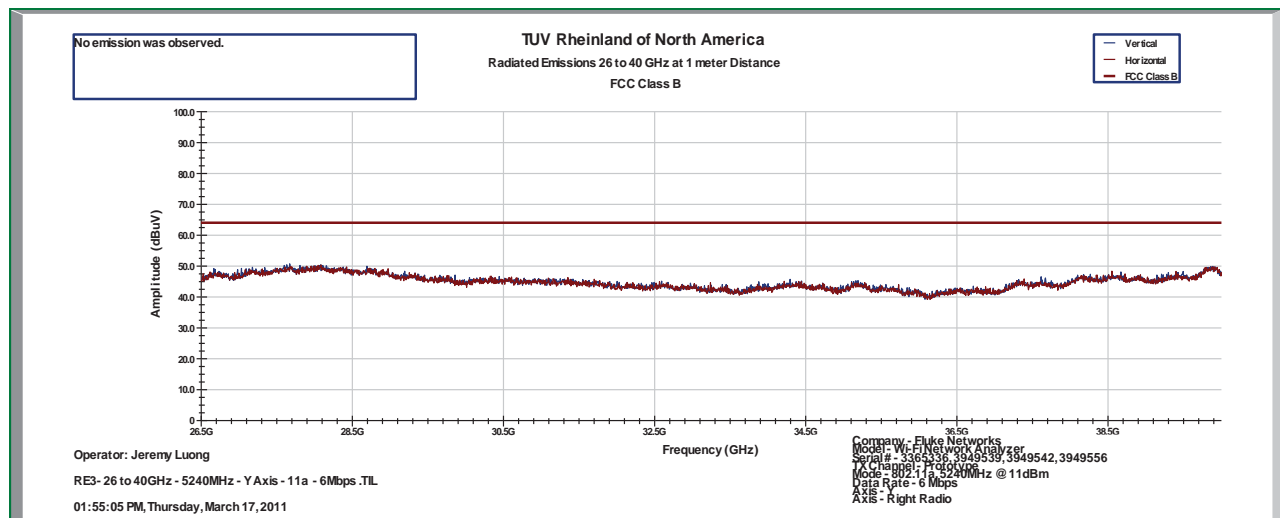

Notes: Limit was extrapolated to 1m distance for 18GHz – 40 GHz range.

SOP 1 Radiated Emissions

Tracking # 31053887.002 Page 10 of 21

EUT Name	OPTIVIEW XG, OPVXG, OPTIVIEW XG-10G, OPVXG-10G, OPVXGPRO, OPVXG-EXPT, OPTIVIEW XG-LAN, OPVXG-LAN, OPVXG-LAN-10G, OPTIVIEW XG WLAN, OPVXG-WLAN	Date	March 17, 2011
EUT Model	3365336, 3949539, 3949542, 3949556, 3949616, 4020634	Temp / Hum in	23°C / 39%rh
EUT Serial	Prototype	Temp / Hum out	N/A
EUT Config.	Y-Axis, 802.11a at 6Mbps	Line AC	120Vac 60Hz
Standard	CFR47 Part 15 Subpart C	RBW / VBW	1 MHz / 3MHz
Dist/Ant Used	3m - EMCO3115 / 1m - RA42-K-F-4B-C	Performed by	Jeremy Luong

Above 1GHz Plots for Transmit Mode at 5260 MHz

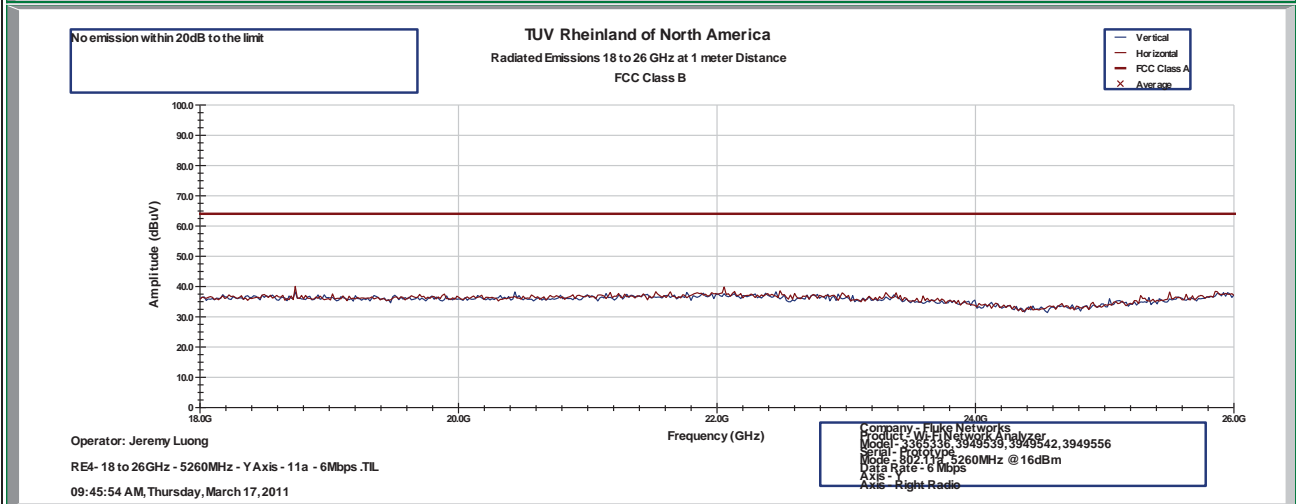
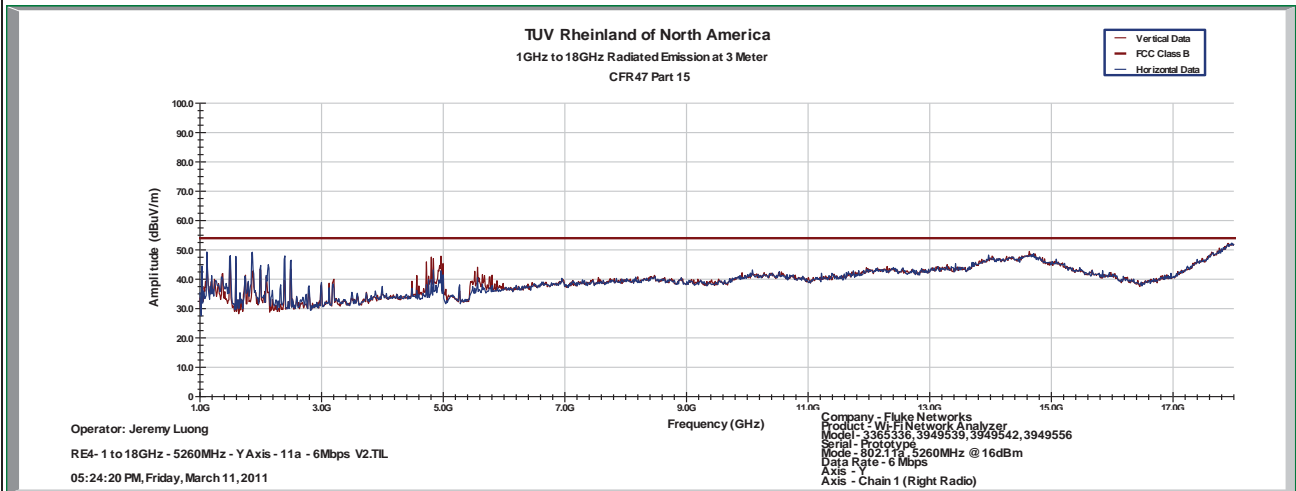

Notes: Limit was extrapolated to 1m distance for 18GHz – 40 GHz range.

SOP 1 Radiated Emissions

Tracking # 31053887.002 Page 11 of 21

EUT Name	OPTIVIEW XG, OPVXG, OPTIVIEW XG-10G, OPVXG-10G, OPVXGPRO, OPVXG-EXPT, OPTIVIEW XG-LAN, OPVXG-LAN, OPVXG-LAN-10G, OPTIVIEW XG WLAN, OPVXG-WLAN	Date	March 17, 2011
EUT Model	3365336, 3949539, 3949542, 3949556, 3949616, 4020634	Temp / Hum in	23°C / 39%rh
EUT Serial	Prototype	Temp / Hum out	N/A
EUT Config.	Y-Axis, 802.11a at 6Mbps	Line AC	120Vac 60Hz
Standard	CFR47 Part 15 Subpart C	RBW / VBW	1 MHz / 3MHz
Dist/Ant Used	1m - RA42-K-F-4B-C	Performed by	Jeremy Luong

Above 1GHz Plots for Transmit Mode at 5260 MHz

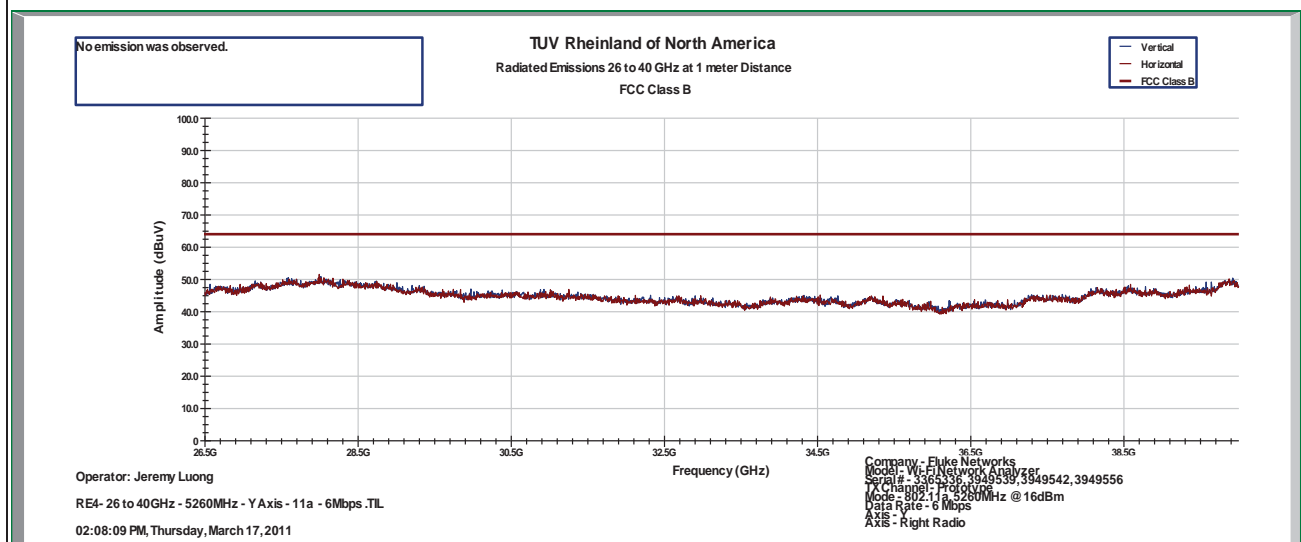

Notes: Limit was extrapolated to 1m distance for 18GHz – 40 GHz range.

SOP 1 Radiated Emissions

Tracking # 31053887.002 Page 12 of 21

EUT Name	OPTIVIEW XG, OPVXG, OPTIVIEW XG-10G, OPVXG-10G, OPVXGPRO, OPVXG-EXPT, OPTIVIEW XG-LAN, OPVXG-LAN, OPVXG-LAN-10G, OPTIVIEW XG WLAN, OPVXG-WLAN	Date	March 17, 2011
EUT Model	3365336, 3949539, 3949542, 3949556, 3949616, 4020634	Temp / Hum in	23°C / 39%rh
EUT Serial	Prototype	Temp / Hum out	N/A
EUT Config.	Y-Axis, 802.11a at 6Mbps	Line AC	120Vac 60Hz
Standard	CFR47 Part 15 Subpart C	RBW / VBW	1 MHz / 3MHz
Dist/Ant Used	3m - EMCO3115 / 1m - RA42-K-F-4B-C	Performed by	Jeremy Luong

Above 1GHz Plots for Transmit Mode at 5300 MHz

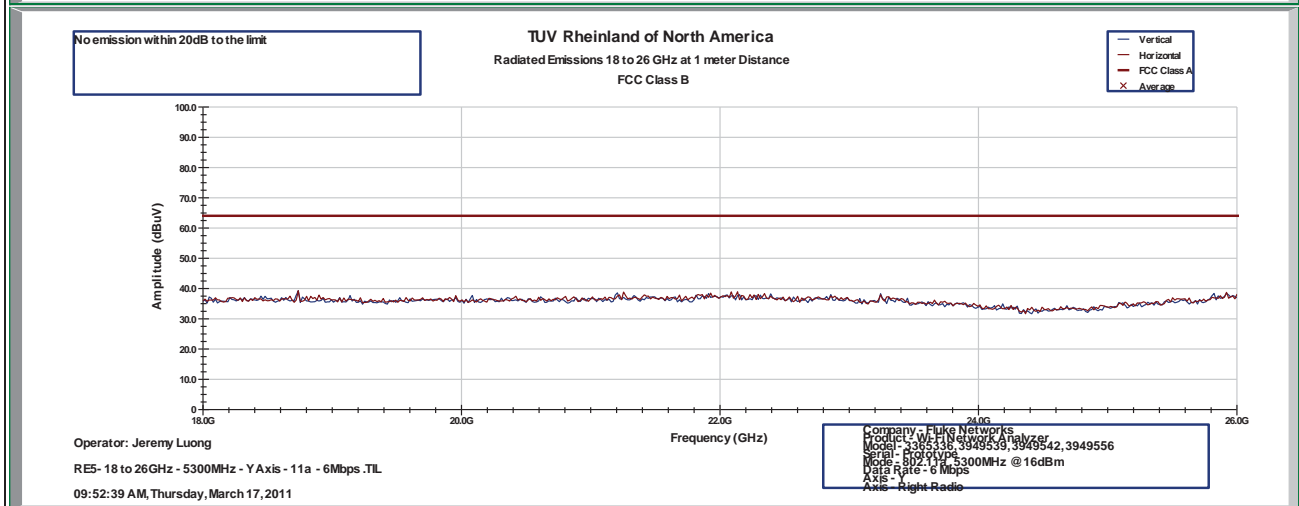
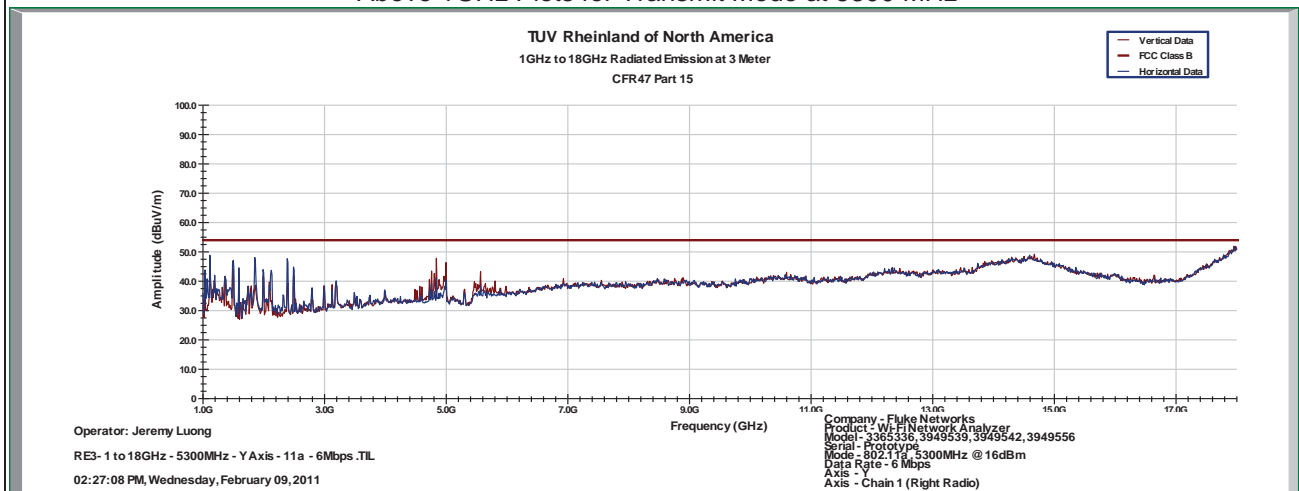

Notes: Limit was extrapolated to 1m distance for 18GHz – 40 GHz range.
 1GHz – 25 GHz Setting: RBW = 1 MHz/ VBW = 3MHz

SOP 1 Radiated Emissions

Tracking # 31053887.002 Page 13 of 21

EUT Name	OPTIVIEW XG, OPVXG, OPTIVIEW XG-10G, OPVXG-10G, OPVXGPRO, OPVXG-EXPT, OPTIVIEW XG-LAN, OPVXG-LAN, OPVXG-LAN-10G, OPTIVIEW XG WLAN, OPVXG-WLAN	Date	March 17, 2011
EUT Model	3365336, 3949539, 3949542, 3949556, 3949616, 4020634	Temp / Hum in	23°C / 39%rh
EUT Serial	Prototype	Temp / Hum out	N/A
EUT Config.	Y-Axis, 802.11a at 6Mbps	Line AC	120Vac 60Hz
Standard	CFR47 Part 15 Subpart C	RBW / VBW	1 MHz / 3MHz
Dist/Ant Used	3m - EMCO3115 / 1m - RA42-K-F-4B-C	Performed by	Jeremy Luong

Above 1GHz Plots for Transmit Mode at 5300 MHz

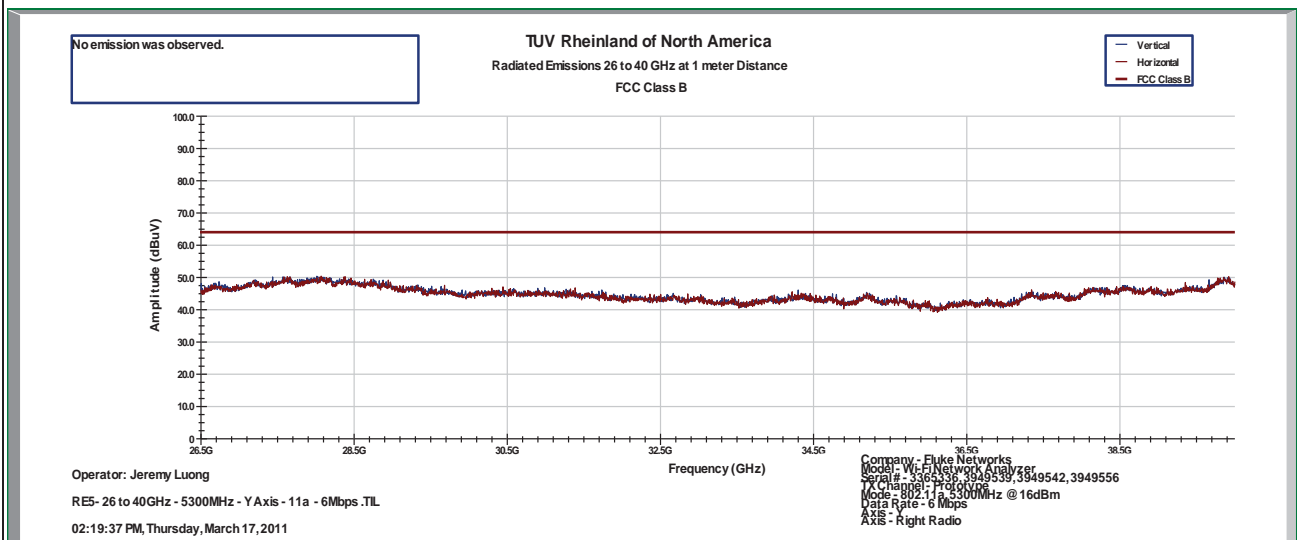

Notes: Limit was extrapolated to 1m distance for 18GHz – 40 GHz range.

SOP 1 Radiated Emissions

Tracking # 31053887.002 Page 14 of 21

EUT Name	OPTIVIEW XG, OPVXG, OPTIVIEW XG-10G, OPVXG-10G, OPVXGPRO, OPVXG-EXPT, OPTIVIEW XG-LAN, OPVXG-LAN, OPVXG-LAN-10G, OPTIVIEW XG WLAN, OPVXG-WLAN	Date	March 11, 2011
EUT Model	3365336, 3949539, 3949542, 3949556, 3949616, 4020634	Temp / Hum in	23°C / 39%rh
EUT Serial	Prototype	Temp / Hum out	N/A
EUT Config.	Y-Axis, 802.11a at 6Mbps	Line AC	120Vac 60Hz
Standard	CFR47 Part 15 Subpart C	RBW / VBW	1 MHz / 3MHz
Dist/Ant Used	3m - EMCO3115 / 1m - RA42-K-F-4B-C	Performed by	Jeremy Luong

Above 1GHz Plots for Transmit Mode at 5320 MHz

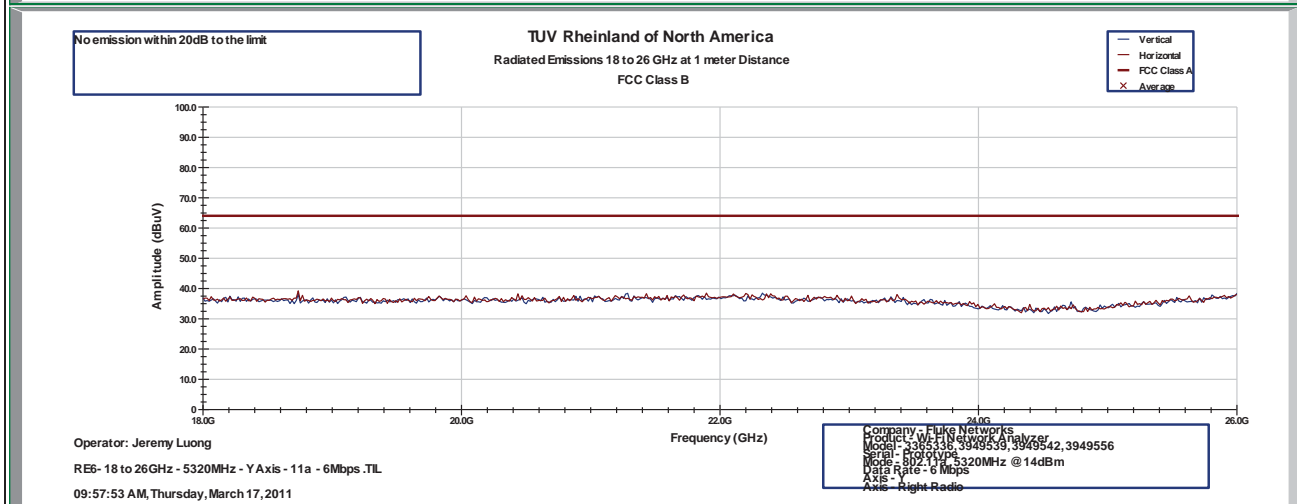
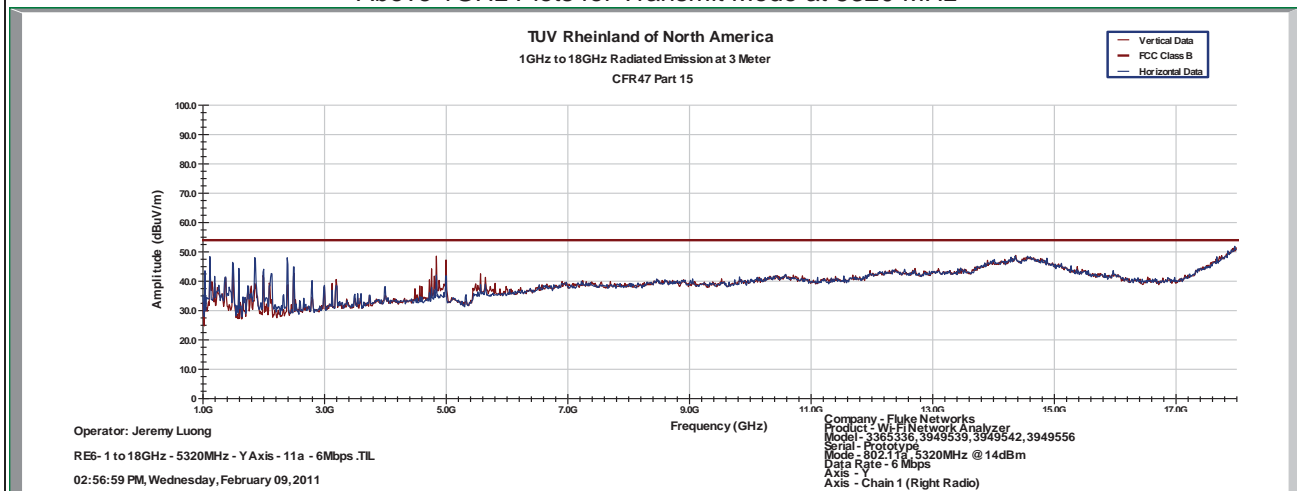

Notes: Limit was extrapolated to 1m distance for 18GHz – 40 GHz range.

SOP 1 Radiated Emissions

Tracking # 31053887.002 Page 15 of 21

EUT Name	OPTIVIEW XG, OPVXG, OPTIVIEW XG-10G, OPVXG-10G, OPVXGPRO, OPVXG-EXPT, OPTIVIEW XG-LAN, OPVXG-LAN, OPVXG-LAN-10G, OPTIVIEW XG WLAN, OPVXG-WLAN	Date	March 17, 2011
EUT Model	3365336, 3949539, 3949542, 3949556, 3949616, 4020634	Temp / Hum in	23°C / 39%rh
EUT Serial	Prototype	Temp / Hum out	N/A
EUT Config.	Y-Axis, 802.11a at 6Mbps	Line AC	120Vac 60Hz
Standard	CFR47 Part 15 Subpart C	RBW / VBW	1 MHz / 3MHz
Dist/Ant Used	3m - EMCO3115 / 1m - RA42-K-F-4B-C	Performed by	Jeremy Luong

Above 1GHz Plots for Transmit Mode at 5320 MHz

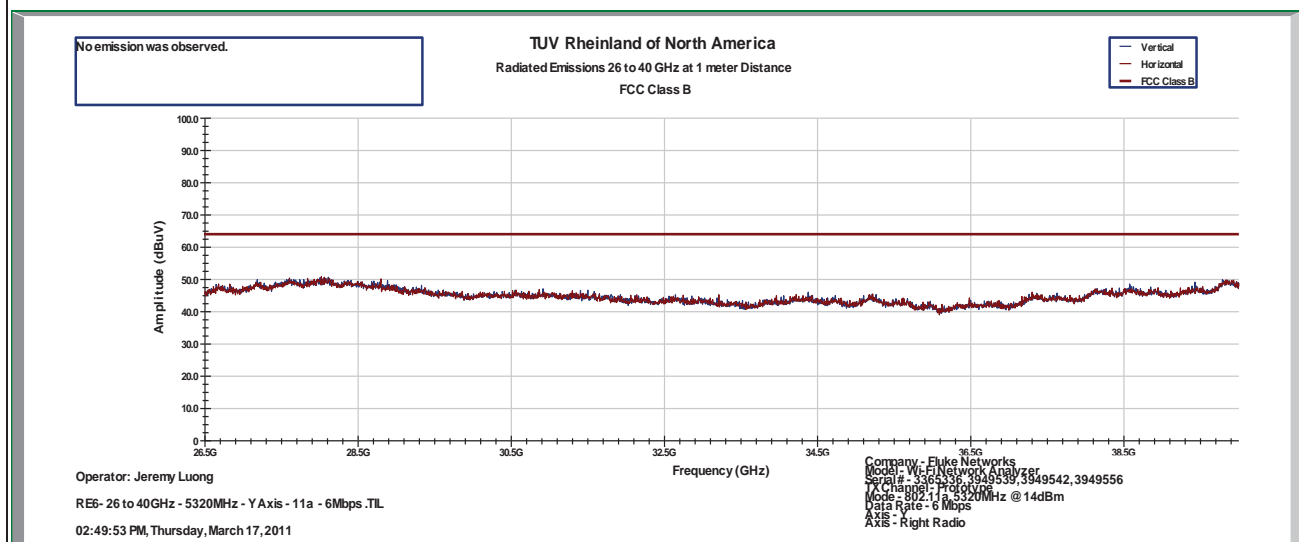

Notes: Limit was extrapolated to 1m distance for 18GHz – 40 GHz range.
 1GHz – 25 GHz Setting: RBW = 1 MHz/ VBW = 3MHz

SOP 1 Radiated Emissions

Tracking # 31053887.002 Page 16 of 21

EUT Name	OPTIVIEW XG, OPVXG, OPTIVIEW XG-10G, OPVXG-10G, OPVXGPRO, OPVXG-EXPT, OPTIVIEW XG-LAN, OPVXG-LAN, OPVXG-LAN-10G, OPTIVIEW XG WLAN, OPVXG-WLAN	Date	March 17, 2011
EUT Model	3365336, 3949539, 3949542, 3949556, 3949616, 4020634	Temp / Hum in	23°C / 39%rh
EUT Serial	Prototype	Temp / Hum out	N/A
EUT Config.	Y-Axis, 802.11a at 6Mbps	Line AC	120Vac 60Hz
Standard	CFR47 Part 15 Subpart C	RBW / VBW	1 MHz / 3MHz
Dist/Ant Used	3m - EMCO3115 / 1m - RA42-K-F-4B-C	Performed by	Jeremy Luong

Above 1GHz Plots for Transmit Mode at 5500 MHz

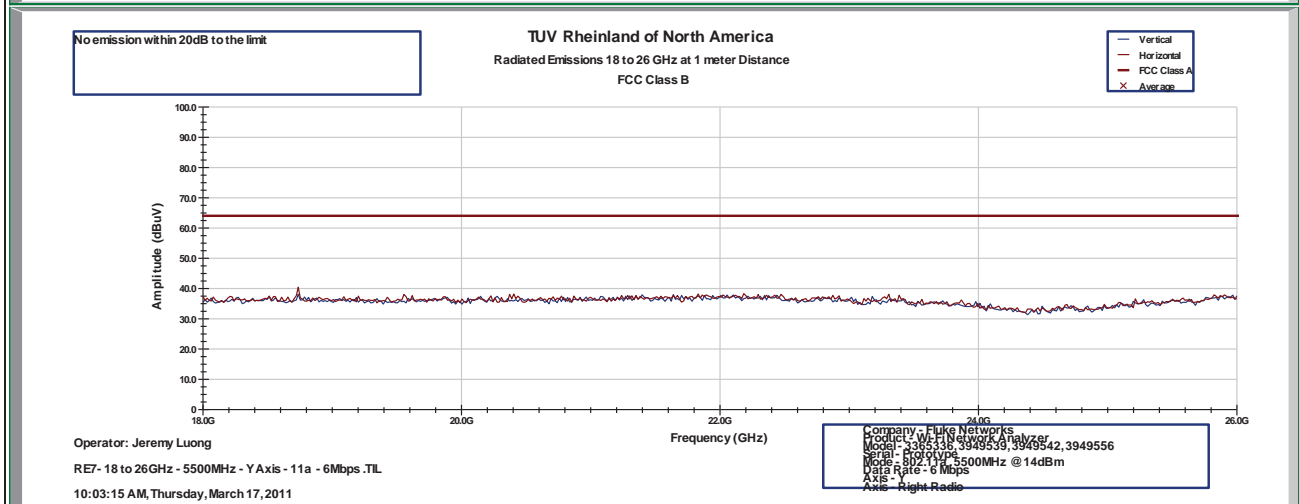
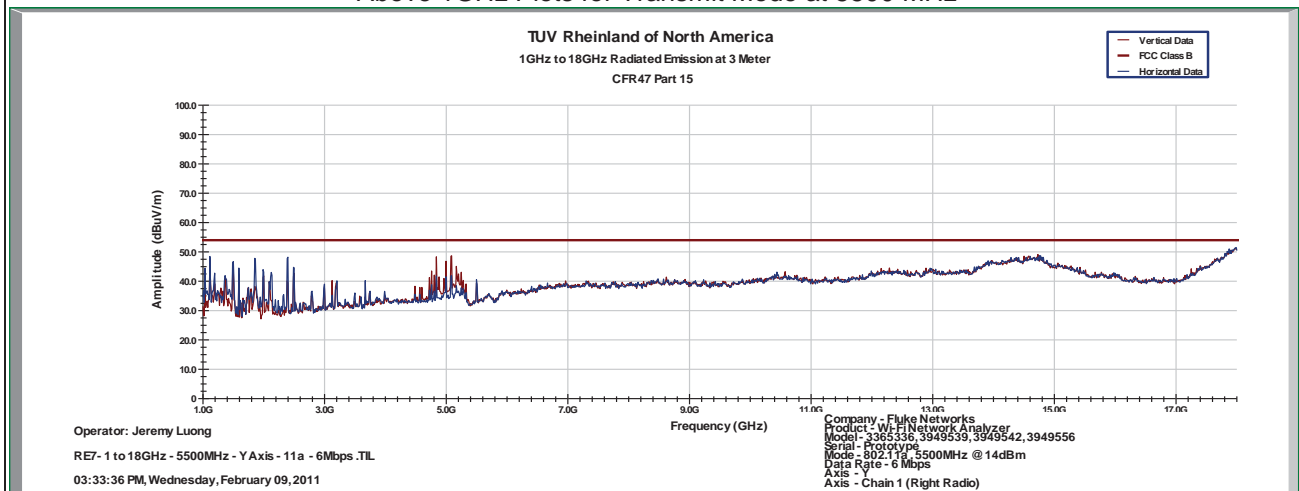

Notes: Limit was extrapolated to 1m distance for 18GHz – 40 GHz range.

SOP 1 Radiated Emissions

Tracking # 31053887.002 Page 17 of 21

EUT Name	OPTIVIEW XG, OPVXG, OPTIVIEW XG-10G, OPVXG-10G, OPVXGPRO, OPVXG-EXPT, OPTIVIEW XG-LAN, OPVXG-LAN, OPVXG-LAN-10G, OPTIVIEW XG WLAN, OPVXG-WLAN	Date	March 17, 2011
EUT Model	3365336, 3949539, 3949542, 3949556, 3949616, 4020634	Temp / Hum in	23°C / 39%rh
EUT Serial	Prototype	Temp / Hum out	N/A
EUT Config.	Y-Axis, 802.11a at 6Mbps	Line AC	120Vac 60Hz
Standard	CFR47 Part 15 Subpart C	RBW / VBW	1 MHz / 3MHz
Dist/Ant Used	1m - RA42-K-F-4B-C	Performed by	Jeremy Luong

Above 1GHz Plots for Transmit Mode at 5500 MHz

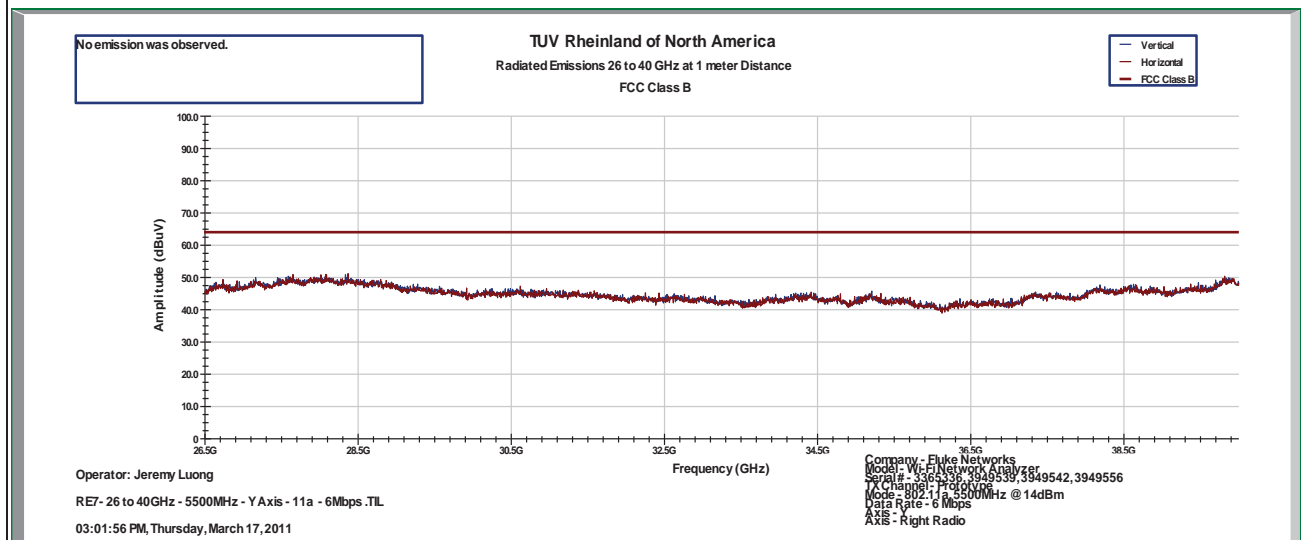

Notes: Limit was extrapolated to 1m distance for 18GHz – 40 GHz range.

SOP 1 Radiated Emissions

Tracking # 31053887.002 Page 18 of 21

EUT Name	OPTIVIEW XG, OPVXG, OPTIVIEW XG-10G, OPVXG-10G, OPVXGPRO, OPVXG-EXPT, OPTIVIEW XG-LAN, OPVXG-LAN, OPVXG-LAN-10G, OPTIVIEW XG WLAN, OPVXG-WLAN	Date	March 17, 2011
EUT Model	3365336, 3949539, 3949542, 3949556, 3949616, 4020634	Temp / Hum in	23°C / 39%rh
EUT Serial	Prototype	Temp / Hum out	N/A
EUT Config.	Y-Axis, 802.11a at 6Mbps	Line AC	120Vac 60Hz
Standard	CFR47 Part 15 Subpart C	RBW / VBW	1 MHz / 3MHz
Dist/Ant Used	3m - EMCO3115 / 1m - RA42-K-F-4B-C	Performed by	Jeremy Luong

Above 1GHz Plots for Transmit Mode at 5600 MHz

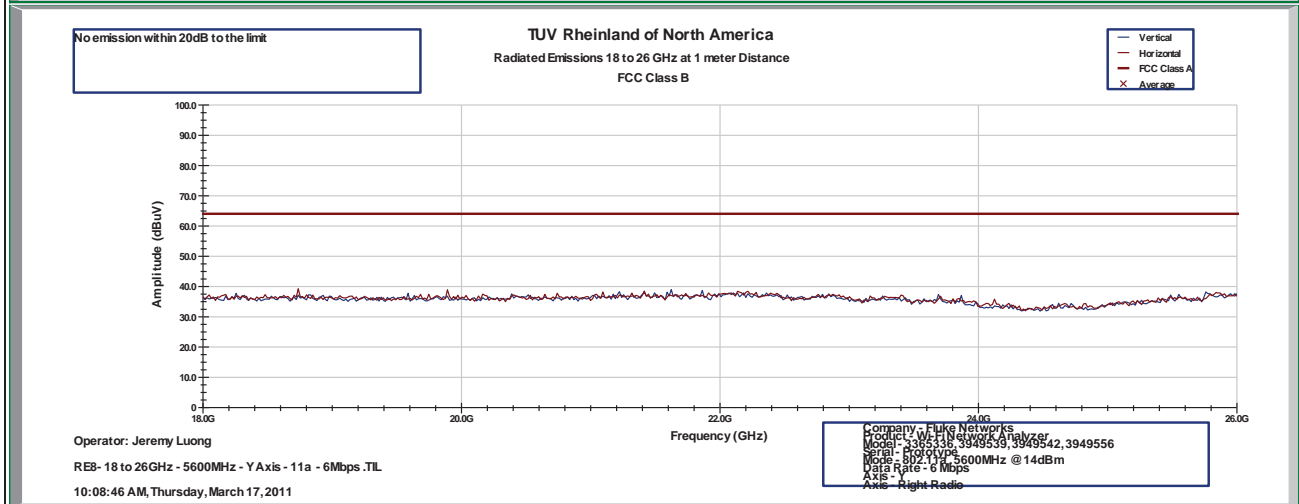
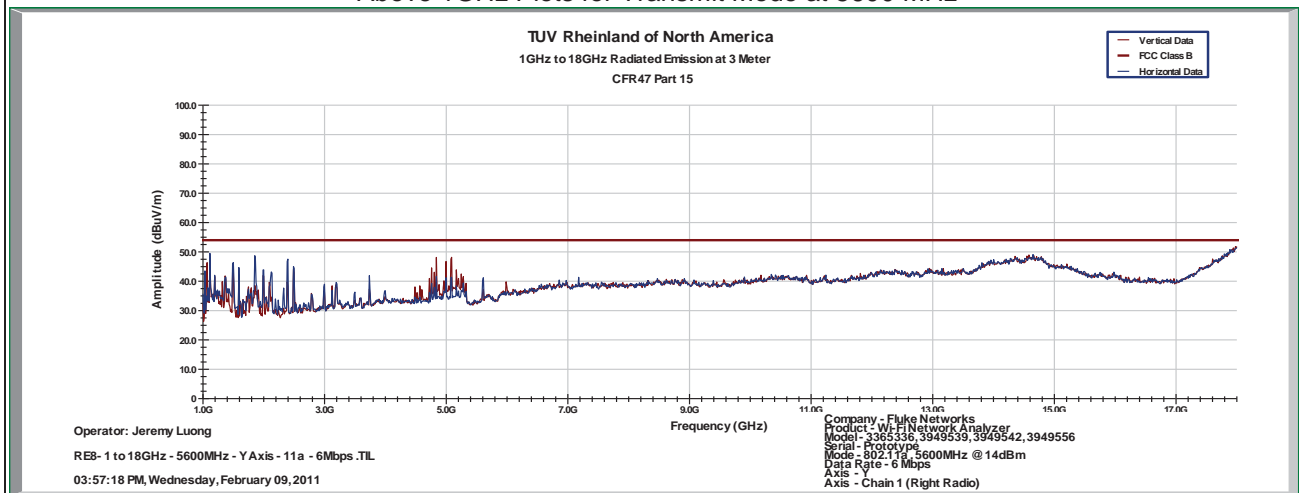

Notes: Limit was extrapolated to 1m distance for 18GHz – 40 GHz range.

SOP 1 Radiated Emissions

Tracking # 31053887.002 Page 19 of 21

EUT Name	OPTIVIEW XG, OPVXG, OPTIVIEW XG-10G, OPVXG-10G, OPVXGPRO, OPVXG-EXPT, OPTIVIEW XG-LAN, OPVXG-LAN, OPVXG-LAN-10G, OPTIVIEW XG WLAN, OPVXG-WLAN	Date	March 17, 2011
EUT Model	3365336, 3949539, 3949542, 3949556, 3949616, 4020634	Temp / Hum in	23°C / 39%rh
EUT Serial	Prototype	Temp / Hum out	N/A
EUT Config.	Y-Axis, 802.11a at 6Mbps	Line AC	120Vac 60Hz
Standard	CFR47 Part 15 Subpart C	RBW / VBW	1 MHz / 3MHz
Dist/Ant Used	3m - EMCO3115 / 1m - RA42-K-F-4B-C	Performed by	Jeremy Luong

Above 1GHz Plots for Transmit Mode at 5600 MHz

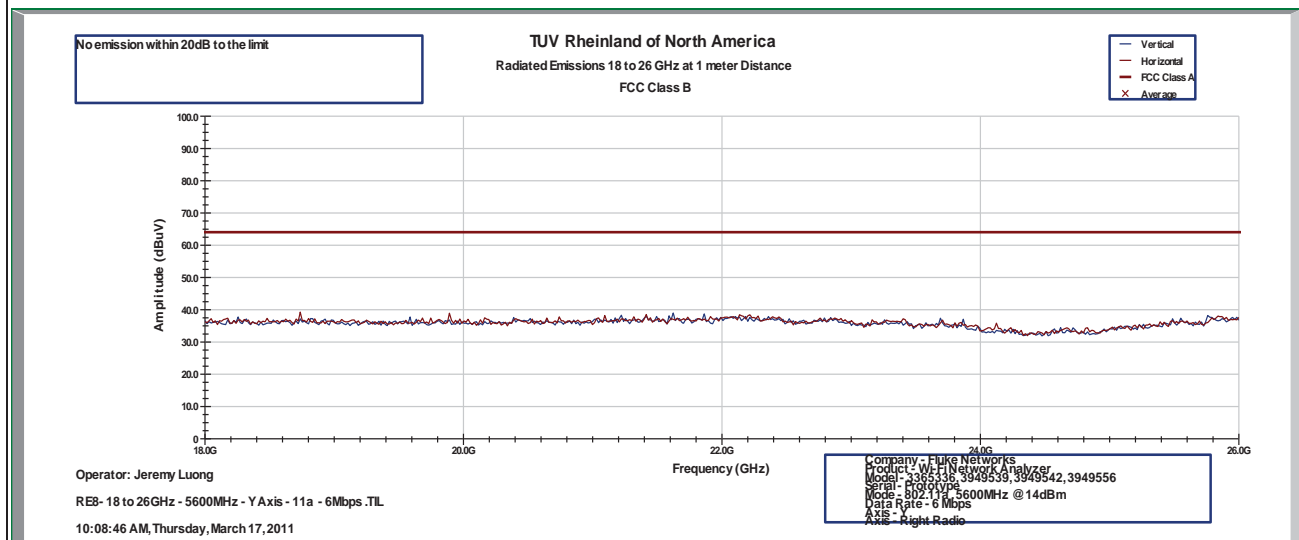

Notes: Limit was extrapolated to 1m distance for 18GHz – 40 GHz range.

SOP 1 Radiated Emissions

Tracking # 31053887.002 Page 20 of 21

EUT Name	OPTIVIEW XG, OPVXG, OPTIVIEW XG-10G, OPVXG-10G, OPVXGPRO, OPVXG-EXPT, OPTIVIEW XG-LAN, OPVXG-LAN, OPVXG-LAN-10G, OPTIVIEW XG WLAN, OPVXG-WLAN	Date	March 17, 2011
EUT Model	3365336, 3949539, 3949542, 3949556, 3949616, 4020634	Temp / Hum in	23°C / 39%rh
EUT Serial	Prototype	Temp / Hum out	N/A
EUT Config.	Y-Axis, 802.11a at 6Mbps	Line AC	120Vac 60Hz
Standard	CFR47 Part 15 Subpart C	RBW / VBW	1 MHz / 3MHz
Dist/Ant Used	3m - EMCO3115 / 1m - RA42-K-F-4B-C	Performed by	Jeremy Luong

Above 1GHz Plots for Transmit Mode at 5700 MHz

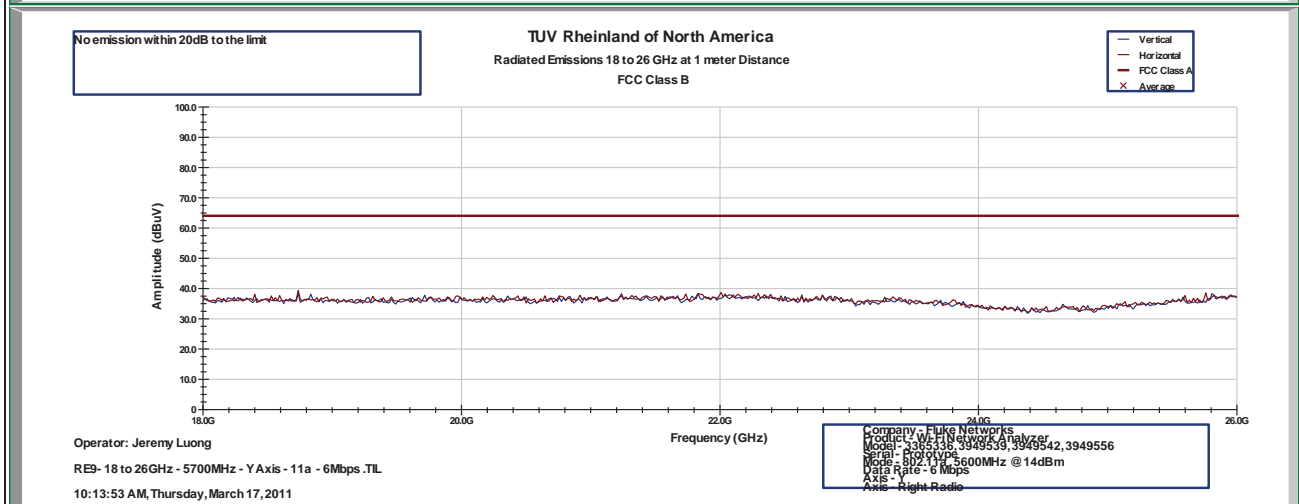
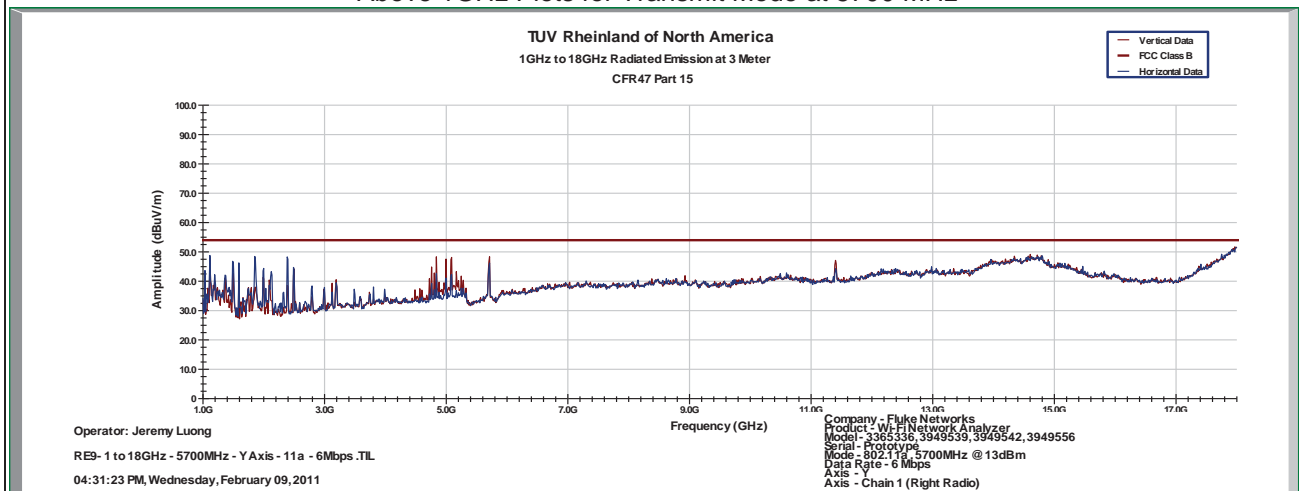

Notes: Limit was extrapolated to 1m distance for 18GHz – 40 GHz range.

SOP 1 Radiated Emissions

Tracking # 31053887.002 Page 21 of 21

EUT Name	OPTIVIEW XG, OPVXG, OPTIVIEW XG-10G, OPVXG-10G, OPVXGPRO, OPVXG-EXPT, OPTIVIEW XG-LAN, OPVXG-LAN, OPVXG-LAN-10G, OPTIVIEW XG WLAN, OPVXG-WLAN	Date	March 17, 2011
EUT Model	3365336, 3949539, 3949542, 3949556, 3949616, 4020634	Temp / Hum in	23°C / 39%rh
EUT Serial	Prototype	Temp / Hum out	N/A
EUT Config.	Y-Axis, 802.11a at 6Mbps	Line AC	120Vac 60Hz
Standard	CFR47 Part 15 Subpart C	RBW / VBW	1 MHz / 3MHz
Dist/Ant Used	3m - EMCO3115 / 1m - RA42-K-F-4B-C	Performed by	Jeremy Luong

Above 1GHz Plots for Transmit Mode at 5700 MHz

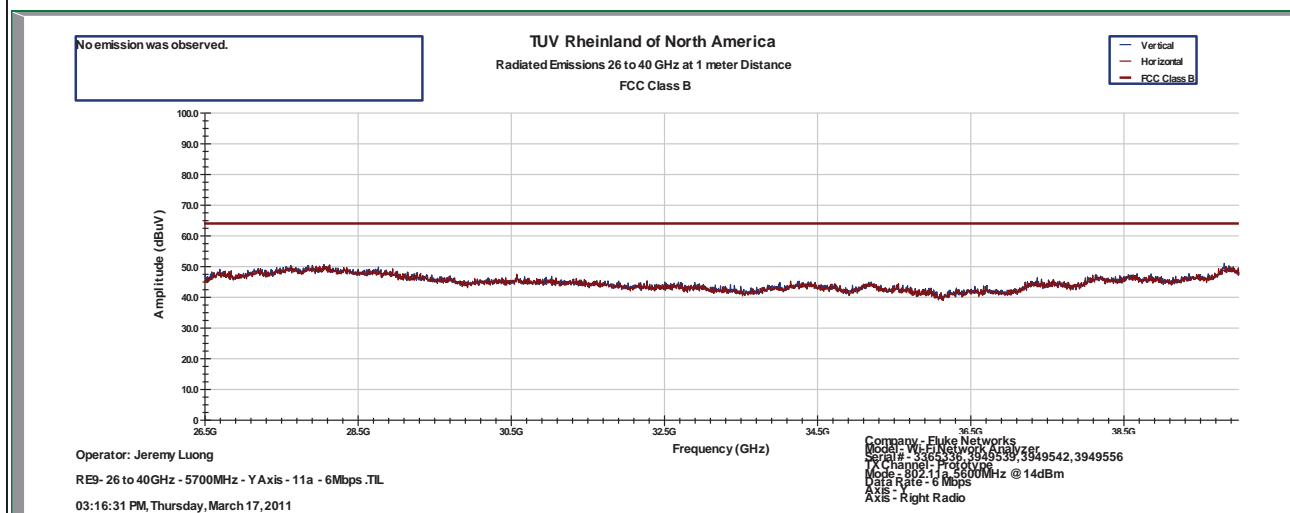

Notes: Limit was extrapolated to 1m distance for 18GHz – 40 GHz range.

SOP 1 Radiated Emissions											Tracking # 31053887.002 Page 1 of 21	
EUT Name		OPTIVIEW XG, OPVXG, OPTIVIEW XG-10G, OPVXG-10G, OPVXGPRO, OPVXG-EXPT, OPTIVIEW XG-LAN, OPVXG-LAN, OPVXG-LAN-10G, OPTIVIEW XG WLAN, OPVXG-WLAN						Date		March 11, 2011		
EUT Model		3365336, 3949539, 3949542, 3949556, 3949616, 4020634						Temp / Hum in		23°C / 38%rh		
EUT Serial		Prototype						Temp / Hum out		N/A		
EUT Config.		Y-Axis, 802.11n HT20 at 6.5Mbps						Line AC / Freq		120Vac/60Hz		
Standard		CFR47 Part 15 Subpart C						RBW / VBW		1 MHz/ 3 MHz		
Dist/Ant Used		3m / EMCO3115 / 1m - RA42-K-F-4B-C						Performed by		Jeremy Luong		
Emission Freq (MHz)	ANT Polar (H/V)	ANT Pos (cm)	Table Pos (deg)	FIM (Pk) (dBuV/m)	FIM Ave (dBuV/m)	Total CF (dBuV)	E-Field Ave (dBuV/m)	Spec Limit (dBuV/m)	Spec Margin (dB)	Type		
Transmitted Data at 5180 MHz @ 11 dBm												
1040.05	H	119	32	57.21	54.69	-9.08	45.61	53.98	-8.37	Spurious		
1120.19	H	111	396	63.56	51.71	-8.62	43.09	53.98	-10.89	Spurious		
1595.41	H	128	149	61.41	42.23	-6.83	35.40	53.98	-18.58	Spurious		
2393.14	H	199	144	55.36	35.89	-3.00	32.89	53.98	-21.09	Spurious		
4840.05	V	197	163	50.14	45.22	2.50	47.72	53.98	-6.26	Spurious		
Transmitted Data at 5220 MHz @ 11 dBm												
1120.16	H	113	394	63.31	51.65	-8.62	43.03	53.98	-10.95	Spurious		
1120.22	V	206	62	58.72	47.60	-8.62	38.98	53.98	-15.00	Spurious		
1495.52	H	251	139	60.41	40.78	-7.69	33.09	53.98	-20.89	Spurious		
1861.21	H	189	177	57.63	44.33	-4.94	39.39	53.98	-14.59	Spurious		
2392.71	H	191	129	57.24	36.85	-3.01	33.84	53.98	-20.14	Spurious		
4800.05	V	192	72	44.79	36.64	2.30	38.94	53.98	-15.04	Spurious		
5000.03	V	191	188	45.73	39.50	2.84	42.34	53.98	-11.64	Spurious		
10438.80	V	124	71	31.10	17.77	11.80	29.58	53.98	-24.40	Harmonic		
Transmitted Data at 5240 MHz @ 11 dBm												
1120.17	H	109	399	62.73	51.41	-8.62	42.79	53.98	-11.19	Spurious		
1495.62	H	171	142	60.03	41.50	-7.69	33.81	53.98	-20.17	Spurious		
1861.15	H	175	248	59.64	44.70	-4.94	39.76	53.98	-14.22	Spurious		
2393.07	H	245	140	56.54	36.03	-3.00	33.03	53.98	-20.95	Spurious		
4800.05	V	199	162	45.36	36.40	2.30	38.70	53.98	-15.28	Spurious		
5000.00	V	199	81	45.66	40.38	2.84	43.22	53.98	-10.76	Spurious		
10482.50	H	145	-19	33.09	19.53	11.82	31.35	53.98	-22.63	Harmonic		
10482.50	V	185	184	32.74	19.49	11.82	31.31	53.98	-22.67	Harmonic		
Spec Margin = E-Field QP - Limit, E-Field QP = FIM QP+ Total CF ± Uncertainty												
Total CF= Amp Gain + Cable Loss + ANT Factor												
Combined Standard Uncertainty $u_c(y) = \pm 3.2$ dB Expanded Uncertainty $U = k u_c(y)$ $k = 2$ for 95% confidence												
Notes: Worst case was observed on Y-axis, 6.5Mbps.												

SOP 1 Radiated Emissions							Tracking # 31053887.002 Page 2 of 21			
EUT Name	OPTIVIEW XG, OPVXG, OPTIVIEW XG-10G, OPVXG-10G, OPVXGPRO, OPVXG-EXPT, OPTIVIEW XG-LAN, OPVXG-LAN, OPVXG-LAN-10G, OPTIVIEW XG WLAN, OPVXG-WLAN					Date	March 11, 2011			
EUT Model	3365336, 3949539, 3949542, 3949556, 3949616, 4020634					Temp / Hum in	23°C / 38%rh			
EUT Serial	Prototype					Temp / Hum out	N/A			
EUT Config.	Y-Axis, 802.11n HT20 at 6.5Mbps					Line AC / Freq	120Vac/60Hz			
Standard	CFR47 Part 15 Subpart C					RBW / VBW	1 MHz/ 3 MHz			
Dist/Ant Used	3m / EMCO3115 / 1m - RA42-K-F-4B-C					Performed by	Jeremy Luong			
Emission Freq (MHz)	ANT Polar (H/V)	ANT Pos (cm)	Table Pos (deg)	FIM (Pk) (dBuV/m)	FIM Ave (dBuV/m)	Total CF (dBuV)	E-Field Ave (dBuV/m)	Spec Limit (dBuV/m)	Spec Margin (dB)	Type
Transmitted Data at 5260 MHz @ 14.5dBm										
1040.02	H	125	198	58.99	54.61	-9.08	45.53	53.98	-8.45	Spurious
1120.19	H	204	392	62.15	50.87	-8.62	42.25	53.98	-11.73	Spurious
1861.03	H	131	215	60.01	45.77	-4.94	40.83	53.98	-13.15	Spurious
2392.80	H	249	136	55.55	36.43	-3.01	33.42	53.98	-20.56	Spurious
4800.06	V	181	161	45.13	35.99	2.30	38.29	53.98	-15.69	Spurious
5000.06	V	179	435	47.53	40.84	2.84	43.68	53.98	-10.30	Spurious
10523	H	151	328	39.73	26.57	11.83	38.4	53.98	-15.58	Harmonic
10524.4	V	161	55	35.48	24.3	11.83	36.12	53.98	-17.86	Harmonic
Transmitted Data at 5300 MHz @ 14.5dBm										
1120.26	H	198	334	61.05	47.40	-8.62	38.78	53.98	-15.20	Spurious
1861.17	H	139	167	59.33	44.87	-4.94	39.93	53.98	-14.05	Spurious
2393.28	H	193	134	59.17	37.11	-3.00	34.11	53.98	-19.87	Spurious
4800.12	V	194	426	46.42	37.08	2.30	39.38	53.98	-14.60	Spurious
5000.06	V	230	163	48.68	42.13	2.84	44.97	53.98	-9.01	Spurious
10599.20	V	260	359	34.65	21.70	11.78	33.49	53.98	-20.49	Harmonic
10599.30	H	283	-67	36.05	21.23	11.78	33.01	53.98	-20.97	Harmonic
Transmitted Data at 5320 MHz @ 14.5dBm										
1200.10	H	201	321	53.77	47.95	-8.00	39.95	53.98	-14.03	Spurious
1595.38	H	139	199	61.32	42.40	-6.83	35.57	53.98	-18.41	Spurious
2392.95	H	189	127	58.62	37.36	-3.00	34.36	53.98	-19.62	Spurious
4800.09	V	135	432	44.17	35.08	2.30	37.38	53.98	-16.60	Spurious
10639.30	V	87	144	33.79	20.20	11.70	31.90	53.98	-22.08	Harmonic
10639.30	H	99	320	32.53	19.39	11.70	31.09	53.98	-22.89	Harmonic
Spec Margin = E-Field QP - Limit, E-Field QP = FIM QP+ Total CF ± Uncertainty										
Total CF= Amp Gain + Cable Loss + ANT Factor										
Combined Standard Uncertainty $u_c(y) = \pm 3.2$ dB Expanded Uncertainty $U = k u_c(y)$ $k = 2$ for 95% confidence										
Notes: Worst case was observed on Y-axis, 6.5Mbps.										

SOP 1 Radiated Emissions							Tracking # 31053887.002 Page 3 of 21			
EUT Name	OPTIVIEW XG, OPVXG, OPTIVIEW XG-10G, OPVXG-10G, OPVXGPRO, OPVXG-EXPT, OPTIVIEW XG-LAN, OPVXG-LAN, OPVXG-LAN-10G, OPTIVIEW XG WLAN, OPVXG-WLAN					Date	March 11, 2011			
EUT Model	3365336, 3949539, 3949542, 3949556, 3949616, 4020634					Temp / Hum in	23°C / 38%rh			
EUT Serial	Prototype					Temp / Hum out	N/A			
EUT Config.	Y-Axis, 802.11n HT20 at 6.5Mbps					Line AC / Freq	120Vac/60Hz			
Standard	CFR47 Part 15 Subpart C					RBW / VBW	1 MHz/ 3 MHz			
Dist/Ant Used	3m / EMCO3115 / 1m - RA42-K-F-4B-C					Performed by	Jeremy Luong			
Emission Freq (MHz)	ANT Polar (H/V)	ANT Pos (cm)	Table Pos (deg)	FIM (Pk) (dBuV/m)	FIM Ave (dBuV/m)	Total CF (dBuV)	E-Field Ave (dBuV/m)	Spec Limit (dBuV/m)	Spec Margin (dB)	Type
Transmitted Data at 5500 MHz @ 14.5dBm										
1120.00	V	117	55	60.52	47.19	-8.62	38.57	53.98	-15.41	Spurious
1197.53	H	100	163	60.43	36.88	-8.01	28.86	53.98	-25.12	Spurious
1199.96	H	101	3	53.79	46.63	-8.00	38.63	53.98	-15.35	Spurious
1598.88	H	100	197	60.66	37.85	-6.81	31.04	53.98	-22.94	Spurious
2393.55	H	143	134	57.82	34.16	-3.00	31.16	53.98	-22.82	Spurious
2488.55	V	149	171	51.46	28.39	-2.68	25.71	53.98	-28.27	Spurious
5079.93	V	189	116	49.18	44.52	3.11	47.63	53.98	-6.35	Spurious
11000.00	V	104	188	24.07	12.17	12.26	36.33	53.98	-17.65	Harmonic
11000.00	H	104	188	25.32	12.38	12.17	24.54	53.98	-29.44	Harmonic
Transmitted Data at 5600 MHz @ 11 dBm										
1040.00	H	119	186	57.64	56.07	-9.08	46.99	53.98	-6.99	Spurious
1119.95	H	117	27	63.32	55.61	-8.62	46.99	53.98	-6.99	Spurious
1495.60	H	107	135	62.12	43.69	-7.69	36.00	53.98	-17.98	Spurious
1595.51	H	99	200	60.62	42.33	-6.83	35.50	53.98	-18.48	Spurious
2393.07	H	145	128	55.96	34.42	-3.00	31.42	53.98	-22.56	Spurious
4839.93	V	212	147	49.48	45.17	2.50	47.67	53.98	-6.31	Spurious
4999.96	V	176	109	48.29	43.09	2.84	45.93	53.98	-8.05	Spurious
5279.89	V	252	384	45.68	35.78	3.64	39.43	53.98	-14.55	Spurious
11200.00	H	100	206	31.37	17.70	12.38	30.08	53.98	-23.90	Harmonic
11200.10	V	153	19	30.46	18.13	12.38	30.51	53.98	-23.47	Harmonic
Transmitted Data at 5700 MHz @ 14.5dBm										
1040.03	H	122	193	59.24	56.52	-9.08	47.44	53.98	-6.54	Spurious
1119.99	H	122	31	62.45	48.54	-8.62	39.92	53.98	-14.06	Spurious
1493.85	H	113	132	61.71	38.98	-7.69	31.29	53.98	-22.69	Spurious
1598.37	H	131	191	59.72	37.23	-6.81	30.42	53.98	-23.56	Spurious
1866.92	H	130	216	58.76	42.29	-4.90	37.39	53.98	-16.59	Spurious
1991.28	V	228	8	57.61	31.19	-4.74	26.45	53.98	-27.53	Spurious
1998.71	V	228	8	54.62	4.74	-4.74	0.00	53.98	-53.98	Spurious
2093.56	V	222	134	49.14	29.89	-4.58	25.31	53.98	-28.67	Spurious
2392.94	H	147	132	55.74	34.38	-3.00	31.38	53.98	-22.60	Spurious
4839.96	V	147	104	48.62	44.08	2.50	46.58	53.98	-7.40	Spurious

4999.98	V	202	154	50.00	45.69	2.84	48.53	53.98	-5.45	Spurious
5080.01	V	199	161	50.42	45.61	3.11	48.72	53.98	-5.26	Spurious
5706.40	H	150	220	48.13	36.10	4.34	40.44	53.98	-13.54	Spurious
5707.18	V	212	150	53.57	42.74	4.34	47.08	53.98	-6.90	Spurious
11400.00	V	147	160	34.39	20.82	12.73	33.54	53.98	-20.44	Harmonic
11408.90	H	147	157	24.56	18.97	12.74	31.71	53.98	-22.27	Harmonic
Spec Margin = E-Field QP - Limit, E-Field QP = FIM QP+ Total CF ± Uncertainty										
Total CF= Amp Gain + Cable Loss + ANT Factor										
Combined Standard Uncertainty $u_c(y) = \pm 3.2$ dB Expanded Uncertainty $U = ku_c(y)$ $k = 2$ for 95% confidence										
Notes: Worst case was observed on Y-axis, 6.5Mbps.										

SOP 1 Radiated Emissions

Tracking # 31053887.002 Page 4 of 21

EUT Name	OPTIVIEW XG, OPVXG, OPTIVIEW XG-10G, OPVXG-10G, OPVXGPRO, OPVXG-EXPT, OPTIVIEW XG-LAN, OPVXG-LAN, OPVXG-LAN-10G, OPTIVIEW XG WLAN, OPVXG-WLAN	Date	March 11, 2011
EUT Model	3365336, 3949539, 3949542, 3949556, 3949616, 4020634	Temp / Hum in	23°C / 39%rh
EUT Serial	Prototype	Temp / Hum out	N/A
EUT Config.	Y-Axis, 802.11n HT20 at 6.5Mbps	Line AC	120Vac 60Hz
Standard	CFR47 Part 15 Subpart C	RBW / VBW	1 MHz / 3MHz
Dist/Ant Used	3m - EMCO3115 / 1m - RA42-K-F-4B-C	Performed by	Jeremy Luong

Above 1GHz Plots for Transmit Mode at 5180 MHz

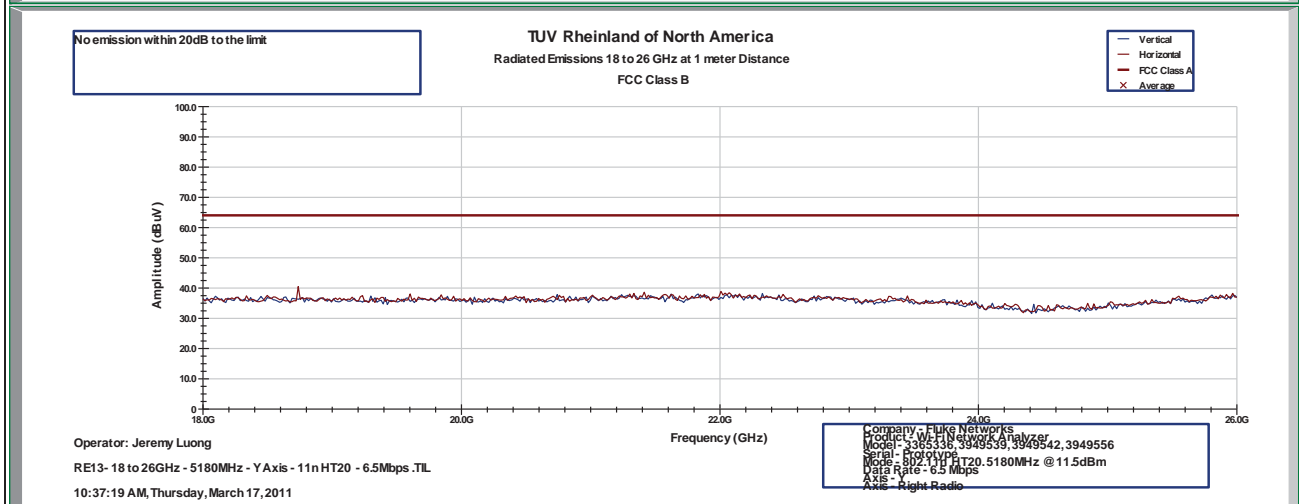
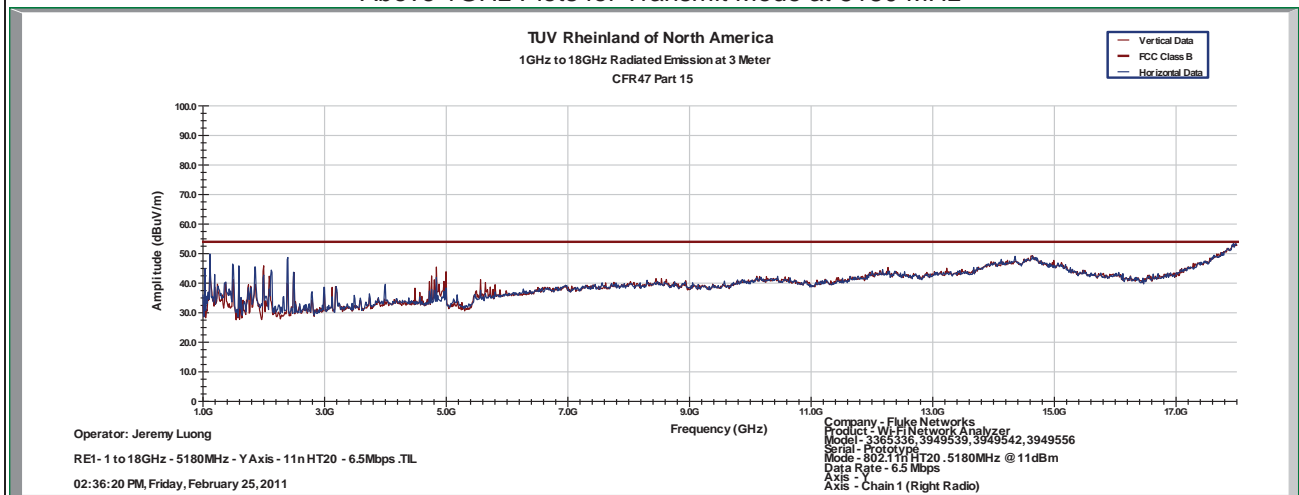

Notes: Limit was extrapolated to 1m distance for 18GHz – 40 GHz range.

SOP 1 Radiated Emissions

Tracking # 31053887.002 Page 5 of 21

EUT Name	OPTIVIEW XG, OPVXG, OPTIVIEW XG-10G, OPVXG-10G, OPVXGPRO, OPVXG-EXPT, OPTIVIEW XG-LAN, OPVXG-LAN, OPVXG-LAN-10G, OPTIVIEW XG WLAN, OPVXG-WLAN	Date	March 18, 2011
EUT Model	3365336, 3949539, 3949542, 3949556, 3949616, 4020634	Temp / Hum in	22°C / 39%rh
EUT Serial	Prototype	Temp / Hum out	N/A
EUT Config.	Y-Axis, 802.11n HT20 at 6.5Mbps	Line AC	120Vac 60Hz
Standard	CFR47 Part 15 Subpart C	RBW / VBW	1 MHz / 3MHz
Dist/Ant Used	3m - EMCO3115 / 1m - RA42-K-F-4B-C	Performed by	Jeremy Luong

Above 1GHz Plots for Transmit Mode at 5180 MHz

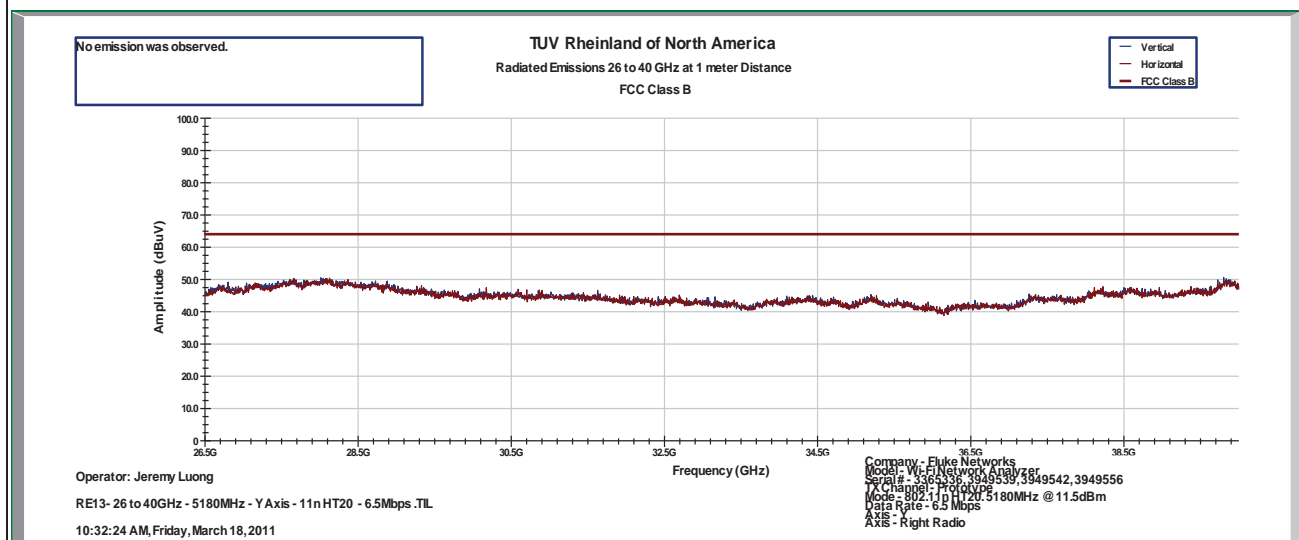

Notes: Limit was extrapolated to 1m distance for 18GHz – 40 GHz range.

SOP 1 Radiated Emissions

Tracking # 31053887.002 Page 6 of 21

EUT Name	OPTIVIEW XG, OPVXG, OPTIVIEW XG-10G, OPVXG-10G, OPVXGPRO, OPVXG-EXPT, OPTIVIEW XG-LAN, OPVXG-LAN, OPVXG-LAN-10G, OPTIVIEW XG WLAN, OPVXG-WLAN	Date	March 17, 2011
EUT Model	3365336, 3949539, 3949542, 3949556, 3949616, 4020634	Temp / Hum in	23°C / 39%rh
EUT Serial	Prototype	Temp / Hum out	N/A
EUT Config.	Y-Axis, 802.11n HT20 at 6.5Mbps	Line AC	120Vac 60Hz
Standard	CFR47 Part 15 Subpart C	RBW / VBW	1 MHz / 3MHz
Dist/Ant Used	3m - EMCO3115 / 1m - RA42-K-F-4B-C	Performed by	Jeremy Luong

Above 1GHz Plots for Transmit Mode at 5220 MHz

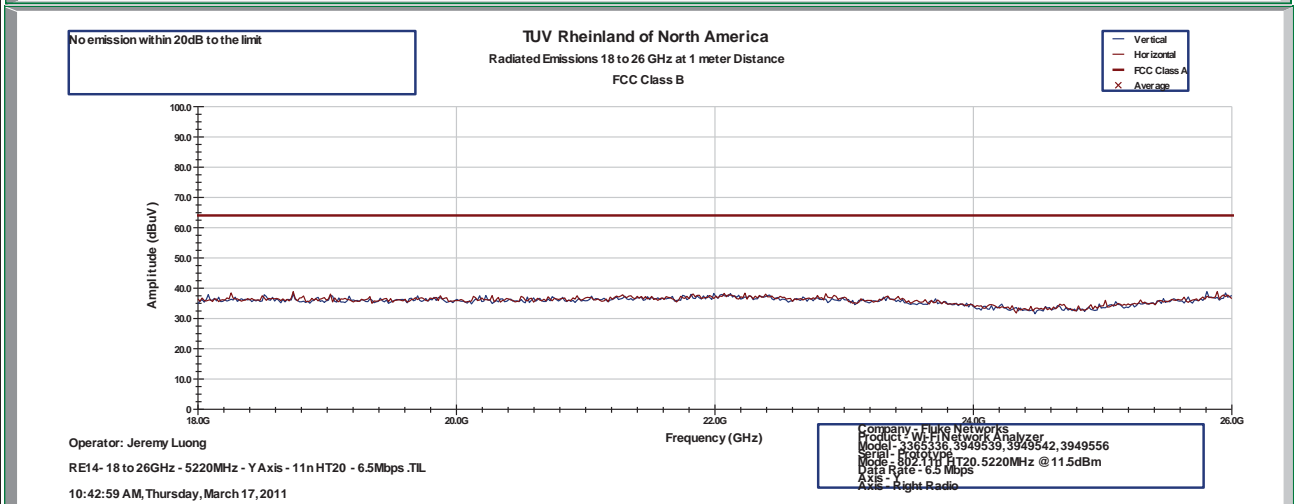
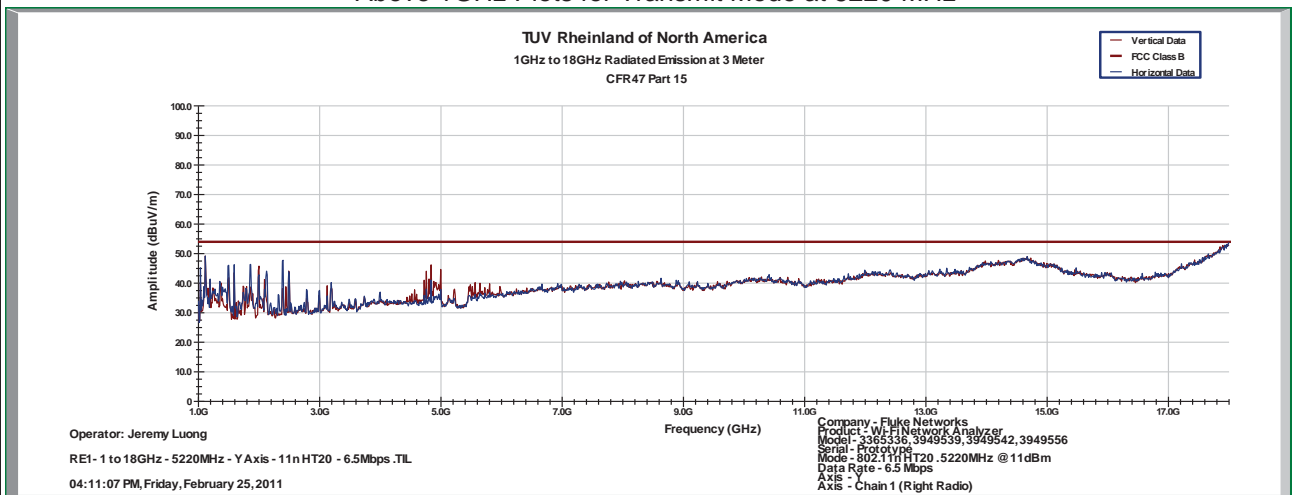

Notes: Limit was extrapolated to 1m distance for 18GHz – 40 GHz range.

SOP 1 Radiated Emissions

Tracking # 31053887.002 Page 7 of 21

EUT Name	OPTIVIEW XG, OPVXG, OPTIVIEW XG-10G, OPVXG-10G, OPVXGPRO, OPVXG-EXPT, OPTIVIEW XG-LAN, OPVXG-LAN, OPVXG-LAN-10G, OPTIVIEW XG WLAN, OPVXG-WLAN	Date	March 18, 2011
EUT Model	3365336, 3949539, 3949542, 3949556, 3949616, 4020634	Temp / Hum in	22°C / 39%rh
EUT Serial	Prototype	Temp / Hum out	N/A
EUT Config.	Y-Axis, 802.11n HT20 at 6.5Mbps	Line AC	120Vac 60Hz
Standard	CFR47 Part 15 Subpart C	RBW / VBW	1 MHz / 3MHz
Dist/Ant Used	3m - EMCO3115 / 1m - RA42-K-F-4B-C	Performed by	Jeremy Luong

Above 1GHz Plots for Transmit Mode at 5220 MHz

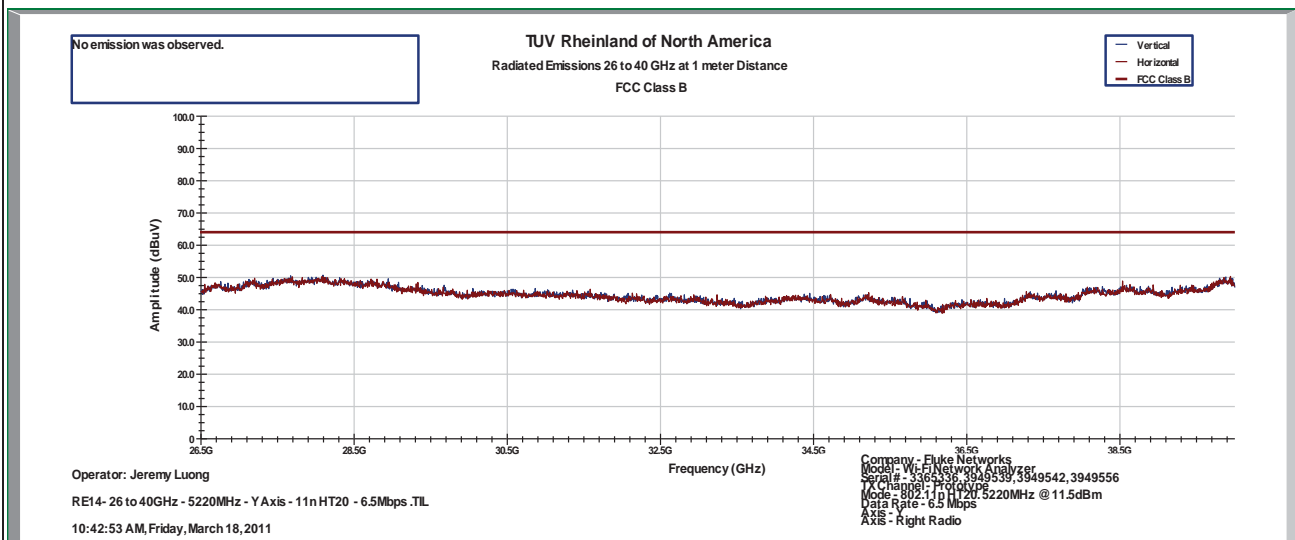

Notes: Limit was extrapolated to 1m distance for 18GHz – 40 GHz range.

SOP 1 Radiated Emissions

Tracking # 31053887.002 Page 8 of 21

EUT Name	OPTIVIEW XG, OPVXG, OPTIVIEW XG-10G, OPVXG-10G, OPVXGPRO, OPVXG-EXPT, OPTIVIEW XG-LAN, OPVXG-LAN, OPVXG-LAN-10G, OPTIVIEW XG WLAN, OPVXG-WLAN	Date	March 17, 2011
EUT Model	3365336, 3949539, 3949542, 3949556, 3949616, 4020634	Temp / Hum in	23°C / 39%rh
EUT Serial	Prototype	Temp / Hum out	N/A
EUT Config.	Y-Axis, 802.11n HT20 at 6.5Mbps	Line AC	120Vac 60Hz
Standard	CFR47 Part 15 Subpart C	RBW / VBW	1 MHz / 3MHz
Dist/Ant Used	3m - EMCO3115 / 1m - RA42-K-F-4B-C	Performed by	Jeremy Luong

Above 1GHz Plots for Transmit Mode at 5240 MHz

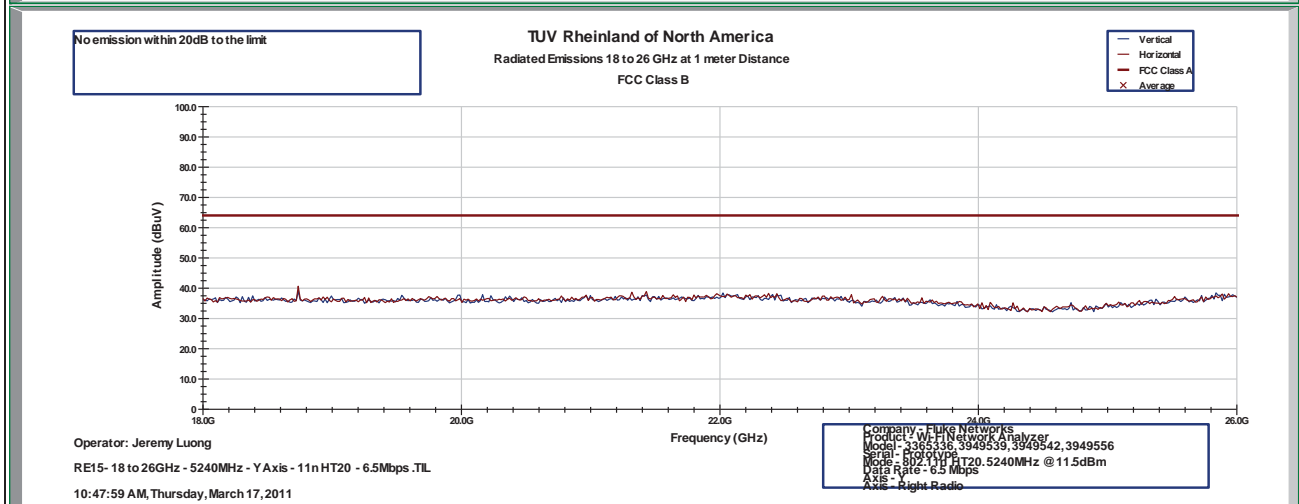
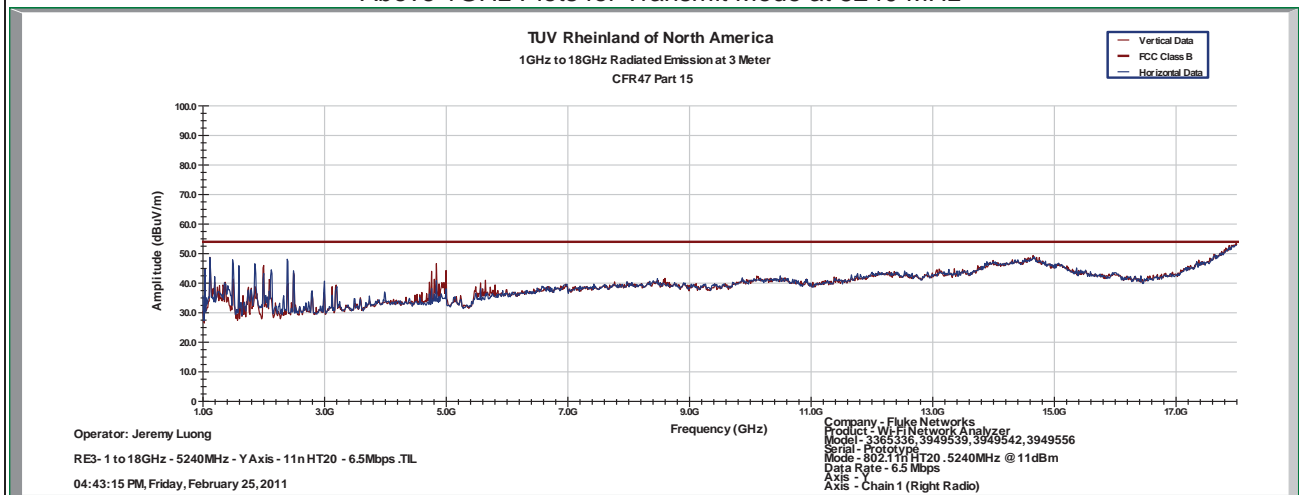

Notes: Limit was extrapolated to 1m distance for 18GHz – 40 GHz range.

SOP 1 Radiated Emissions

Tracking # 31053887.002 Page 9 of 21

EUT Name	OPTIVIEW XG, OPVXG, OPTIVIEW XG-10G, OPVXG-10G, OPVXGPRO, OPVXG-EXPT, OPTIVIEW XG-LAN, OPVXG-LAN, OPVXG-LAN-10G, OPTIVIEW XG WLAN, OPVXG-WLAN	Date	March 18, 2011
EUT Model	3365336, 3949539, 3949542, 3949556, 3949616, 4020634	Temp / Hum in	22°C / 39%rh
EUT Serial	Prototype	Temp / Hum out	N/A
EUT Config.	Y-Axis, 802.11n HT20 at 6.5Mbps	Line AC	120Vac 60Hz
Standard	CFR47 Part 15 Subpart C	RBW / VBW	1 MHz / 3MHz
Dist/Ant Used	3m - EMCO3115 / 1m - RA42-K-F-4B-C	Performed by	Jeremy Luong

Above 1GHz Plots for Transmit Mode at 5240 MHz

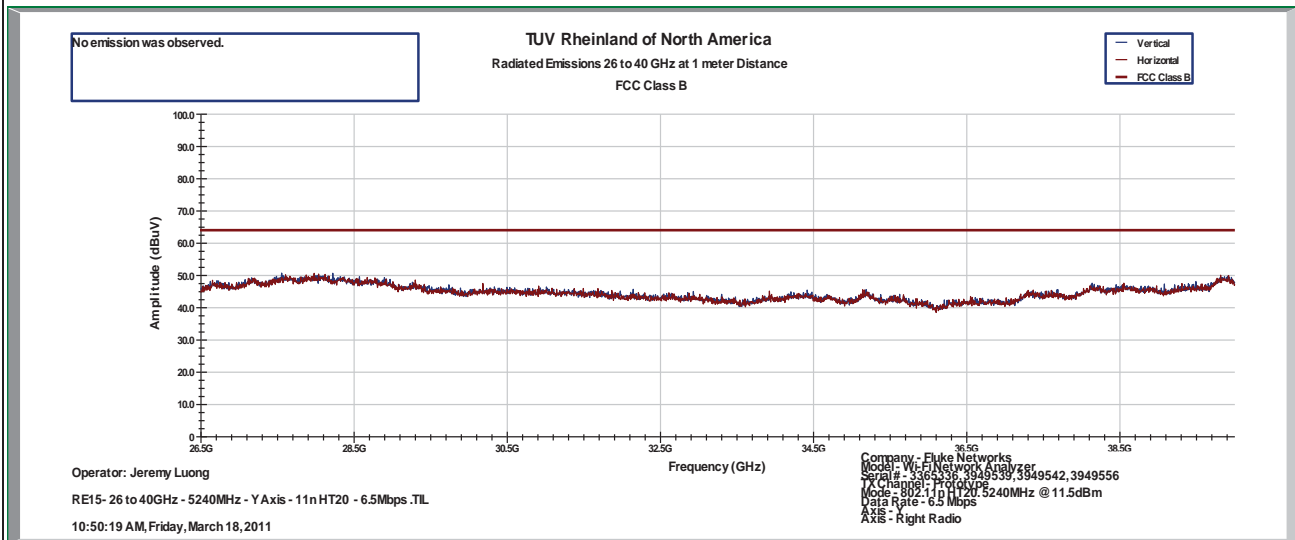

Notes: Limit was extrapolated to 1m distance for 18GHz – 40 GHz range.

SOP 1 Radiated Emissions

Tracking # 31053887.002 Page 10 of 21

EUT Name	OPTIVIEW XG, OPVXG, OPTIVIEW XG-10G, OPVXG-10G, OPVXGPRO, OPVXG-EXPT, OPTIVIEW XG-LAN, OPVXG-LAN, OPVXG-LAN-10G, OPTIVIEW XG WLAN, OPVXG-WLAN	Date	March 11, 2011
EUT Model	3365336, 3949539, 3949542, 3949556, 3949616, 4020634	Temp / Hum in	23°C / 39%rh
EUT Serial	Prototype	Temp / Hum out	N/A
EUT Config.	Y-Axis, 802.11n HT20 at 6.5Mbps	Line AC	120Vac 60Hz
Standard	CFR47 Part 15 Subpart C	RBW / VBW	1 MHz / 3MHz
Dist/Ant Used	3m - EMCO3115 / 1m - RA42-K-F-4B-C	Performed by	Jeremy Luong

Above 1GHz Plots for Transmit Mode at 5260 MHz

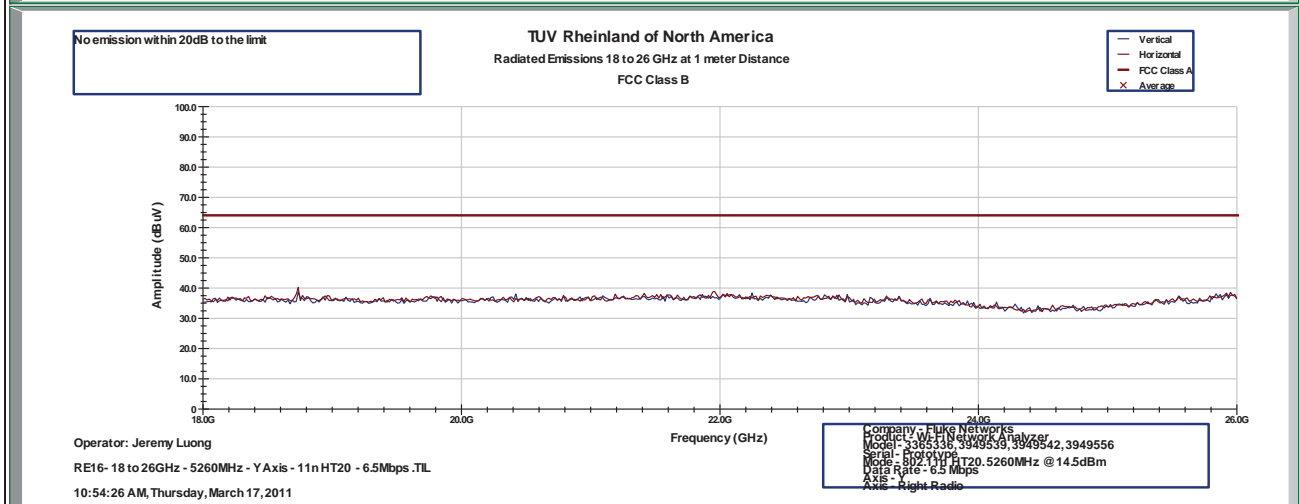
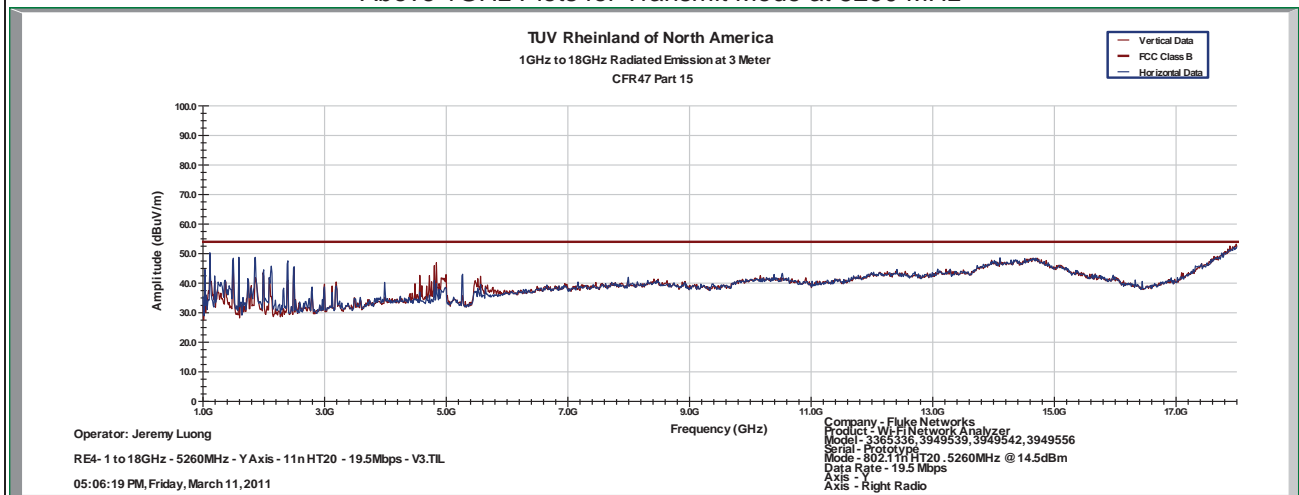

Notes: Limit was extrapolated to 1m distance for 18GHz – 40 GHz range.

SOP 1 Radiated Emissions

Tracking # 31053887.002 Page 11 of 21

EUT Name	OPTIVIEW XG, OPVXG, OPTIVIEW XG-10G, OPVXG-10G, OPVXGPRO, OPVXG-EXPT, OPTIVIEW XG-LAN, OPVXG-LAN, OPVXG-LAN-10G, OPTIVIEW XG WLAN, OPVXG-WLAN	Date	March 18, 2011
EUT Model	3365336, 3949539, 3949542, 3949556, 3949616, 4020634	Temp / Hum in	22°C / 39%rh
EUT Serial	Prototype	Temp / Hum out	N/A
EUT Config.	Y-Axis, 802.11n HT20 at 6.5Mbps	Line AC	120Vac 60Hz
Standard	CFR47 Part 15 Subpart C	RBW / VBW	1 MHz / 3MHz
Dist/Ant Used	3m - EMCO3115 / 1m - RA42-K-F-4B-C	Performed by	Jeremy Luong

Above 1GHz Plots for Transmit Mode at 5260 MHz

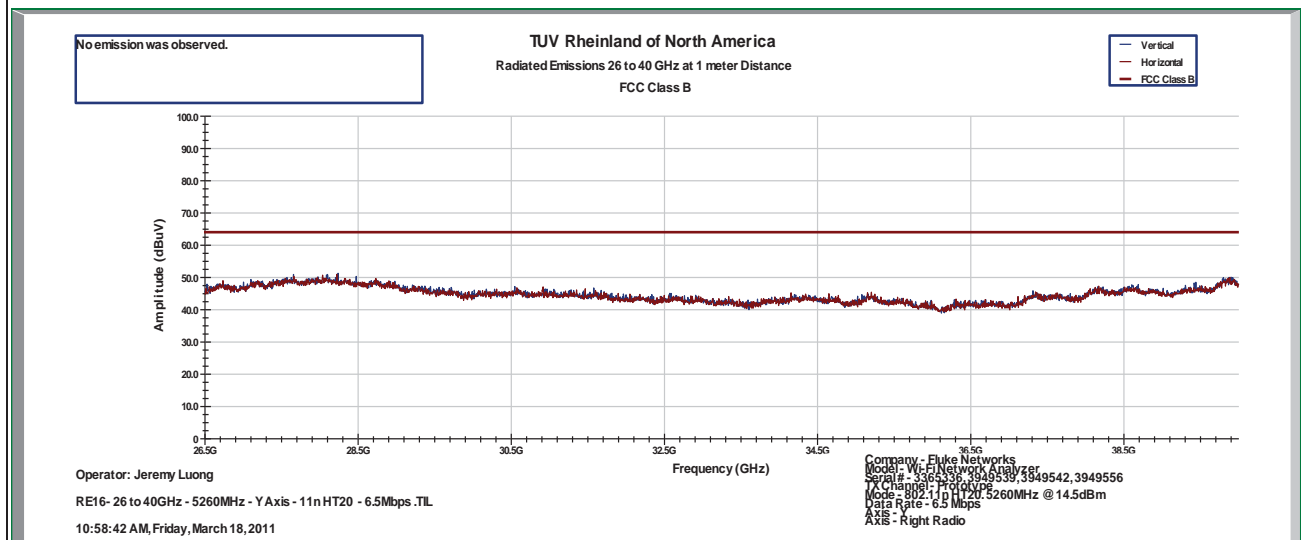

Notes: Limit was extrapolated to 1m distance for 18GHz – 40 GHz range.

SOP 1 Radiated Emissions

Tracking # 31053887.002 Page 12 of 21

EUT Name	OPTIVIEW XG, OPVXG, OPTIVIEW XG-10G, OPVXG-10G, OPVXGPRO, OPVXG-EXPT, OPTIVIEW XG-LAN, OPVXG-LAN, OPVXG-LAN-10G, OPTIVIEW XG WLAN, OPVXG-WLAN	Date	March 17, 2011
EUT Model	3365336, 3949539, 3949542, 3949556, 3949616, 4020634	Temp / Hum in	23°C / 39%rh
EUT Serial	Prototype	Temp / Hum out	N/A
EUT Config.	Y-Axis, 802.11n HT20 at 6.5Mbps	Line AC	120Vac 60Hz
Standard	CFR47 Part 15 Subpart C	RBW / VBW	1 MHz / 3MHz
Dist/Ant Used	3m - EMCO3115 / 1m - RA42-K-F-4B-C	Performed by	Jeremy Luong

Above 1GHz Plots for Transmit Mode at 5300 MHz

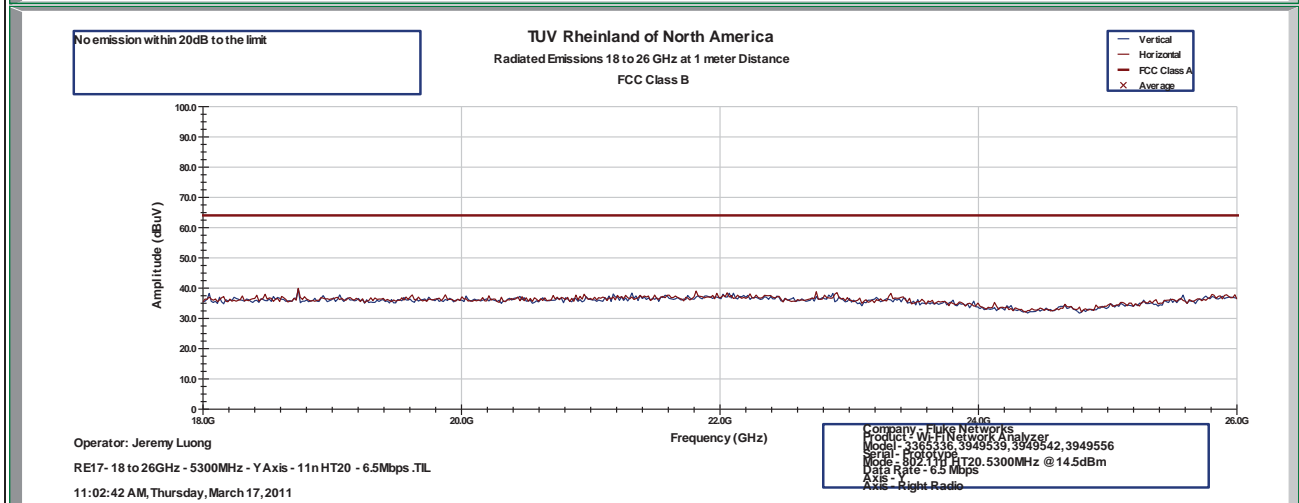
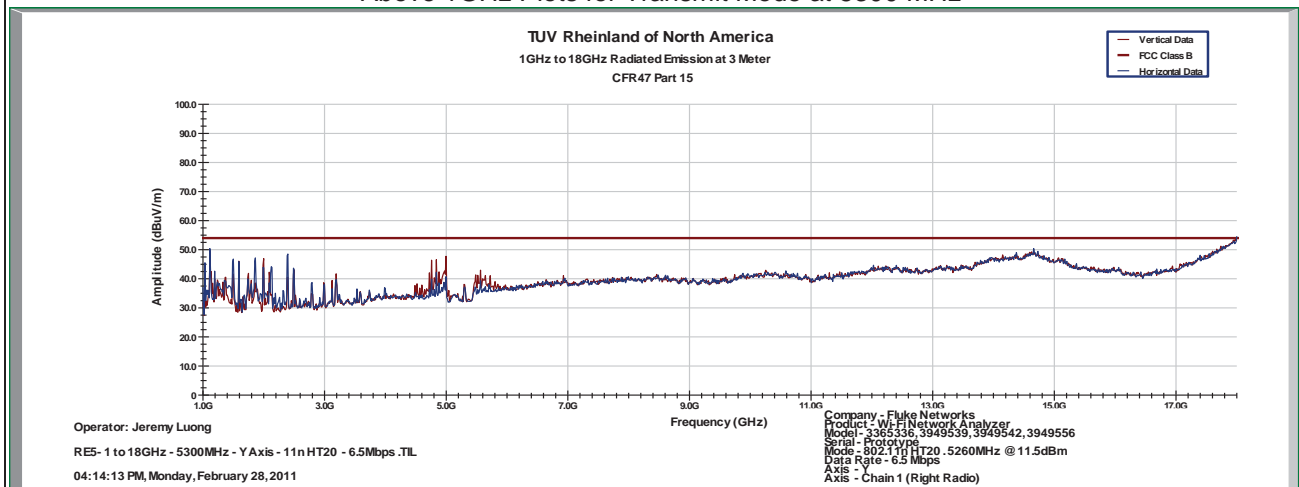

Notes: Limit was extrapolated to 1m distance for 18GHz – 40 GHz range.

SOP 1 Radiated Emissions

Tracking # 31053887.002 Page 13 of 21

EUT Name	OPTIVIEW XG, OPVXG, OPTIVIEW XG-10G, OPVXG-10G, OPVXGPRO, OPVXG-EXPT, OPTIVIEW XG-LAN, OPVXG-LAN, OPVXG-LAN-10G, OPTIVIEW XG WLAN, OPVXG-WLAN	Date	March 18, 2011
EUT Model	3365336, 3949539, 3949542, 3949556, 3949616, 4020634	Temp / Hum in	22°C / 39%rh
EUT Serial	Prototype	Temp / Hum out	N/A
EUT Config.	Y-Axis, 802.11n HT20 at 6.5Mbps	Line AC	120Vac 60Hz
Standard	CFR47 Part 15 Subpart C	RBW / VBW	1 MHz / 3MHz
Dist/Ant Used	1m - RA42-K-F-4B-C	Performed by	Jeremy Luong

Above 1GHz Plots for Transmit Mode at 5300 MHz

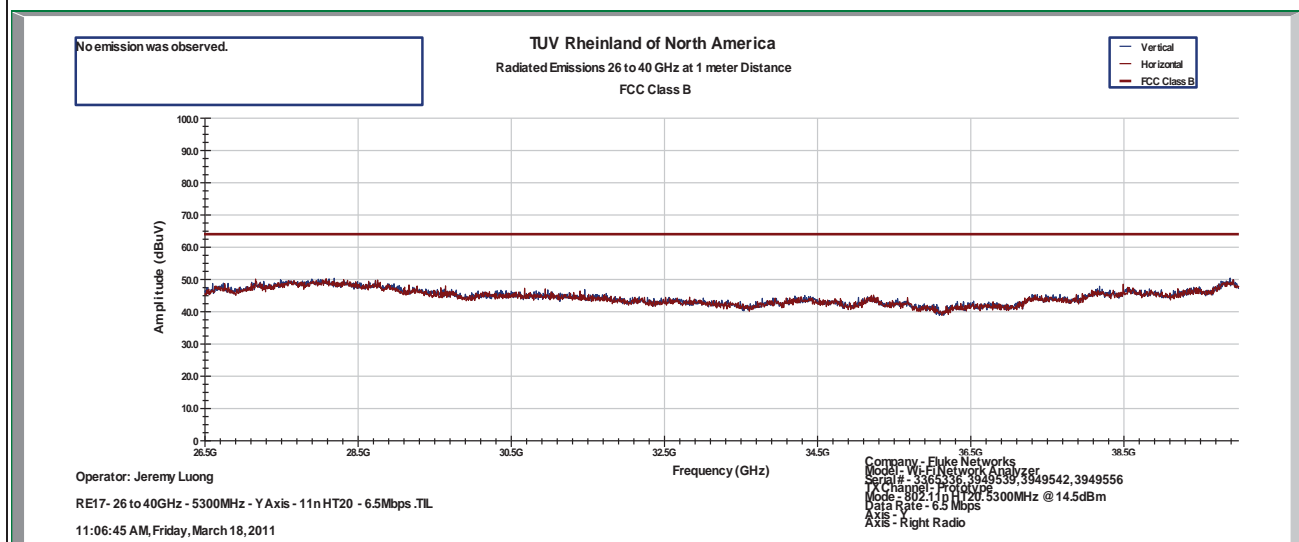

Notes: Limit was extrapolated to 1m distance for 18GHz – 40 GHz range.

SOP 1 Radiated Emissions

Tracking # 31053887.002 Page 14 of 21

EUT Name	OPTIVIEW XG, OPVXG, OPTIVIEW XG-10G, OPVXG-10G, OPVXGPRO, OPVXG-EXPT, OPTIVIEW XG-LAN, OPVXG-LAN, OPVXG-LAN-10G, OPTIVIEW XG WLAN, OPVXG-WLAN	Date	March 17, 2011
EUT Model	3365336, 3949539, 3949542, 3949556, 3949616, 4020634	Temp / Hum in	23°C / 39%rh
EUT Serial	Prototype	Temp / Hum out	N/A
EUT Config.	Y-Axis, 802.11n HT20 at 6.5Mbps	Line AC	120Vac 60Hz
Standard	CFR47 Part 15 Subpart C	RBW / VBW	1 MHz / 3MHz
Dist/Ant Used	3m - EMCO3115 / 1m - RA42-K-F-4B-C	Performed by	Jeremy Luong

Above 1GHz Plots for Transmit Mode at 5320 MHz

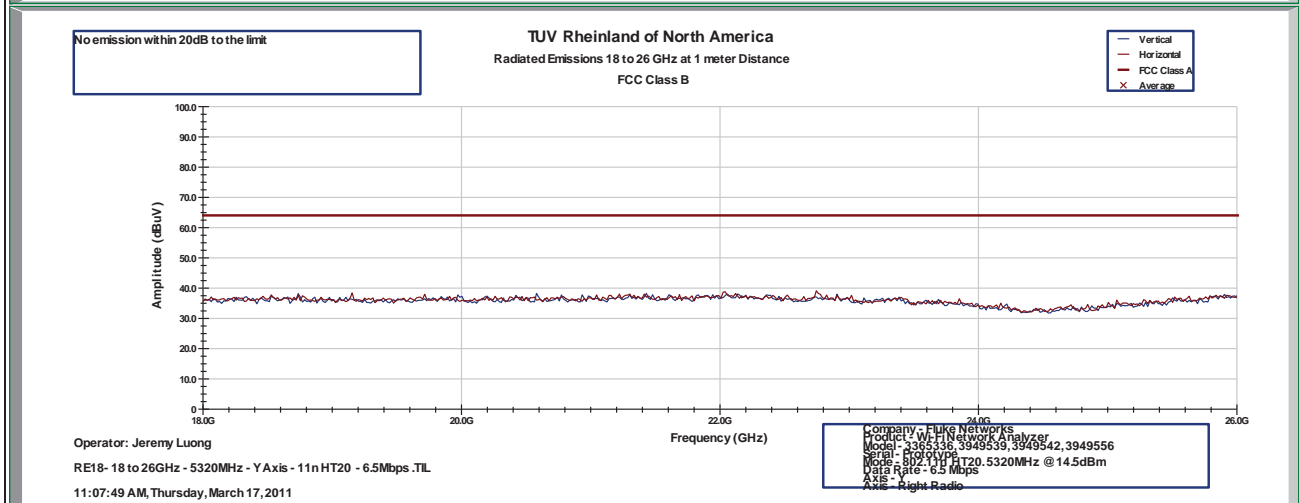
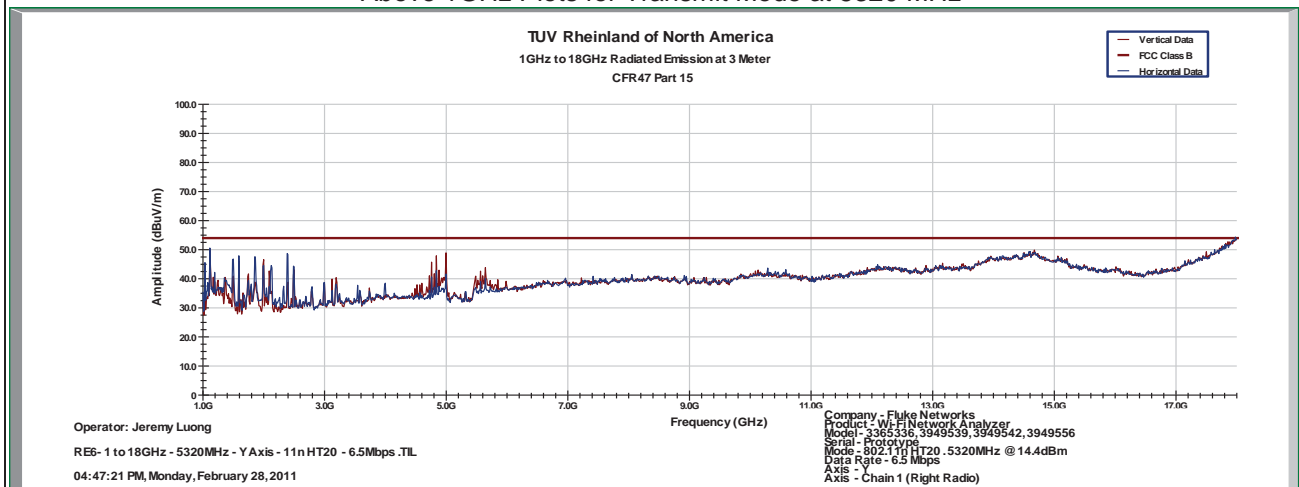

Notes: Limit was extrapolated to 1m distance for 18GHz – 40 GHz range.

SOP 1 Radiated Emissions

Tracking # 31053887.002 Page 15 of 21

EUT Name	OPTIVIEW XG, OPVXG, OPTIVIEW XG-10G, OPVXG-10G, OPVXGPRO, OPVXG-EXPT, OPTIVIEW XG-LAN, OPVXG-LAN, OPVXG-LAN-10G, OPTIVIEW XG WLAN, OPVXG-WLAN	Date	March 18, 2011
EUT Model	3365336, 3949539, 3949542, 3949556, 3949616, 4020634	Temp / Hum in	22°C / 39%rh
EUT Serial	Prototype	Temp / Hum out	N/A
EUT Config.	Y-Axis, 802.11n HT20 at 6.5Mbps	Line AC	120Vac 60Hz
Standard	CFR47 Part 15 Subpart C	RBW / VBW	1 MHz / 3MHz
Dist/Ant Used	1m - RA42-K-F-4B-C	Performed by	Jeremy Luong

Above 1GHz Plots for Transmit Mode at 5320 MHz

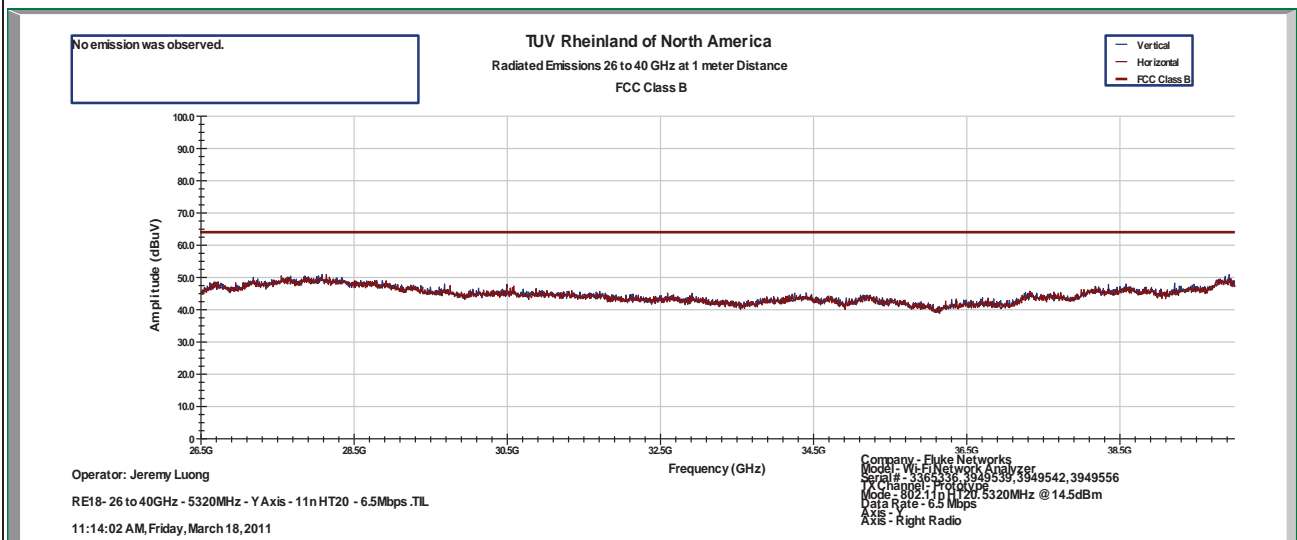

Notes: Limit was extrapolated to 1m distance for 18GHz – 40 GHz range.

SOP 1 Radiated Emissions

Tracking # 31053887.002 Page 16 of 21

EUT Name	OPTIVIEW XG, OPVXG, OPTIVIEW XG-10G, OPVXG-10G, OPVXGPRO, OPVXG-EXPT, OPTIVIEW XG-LAN, OPVXG-LAN, OPVXG-LAN-10G, OPTIVIEW XG WLAN, OPVXG-WLAN	Date	March 17, 2011
EUT Model	3365336, 3949539, 3949542, 3949556, 3949616, 4020634	Temp / Hum in	23°C / 39%rh
EUT Serial	Prototype	Temp / Hum out	N/A
EUT Config.	Y-Axis, 802.11n HT20 at 6.5Mbps	Line AC	120Vac 60Hz
Standard	CFR47 Part 15 Subpart C	RBW / VBW	1 MHz / 3MHz
Dist/Ant Used	3m - EMCO3115 / 1m - RA42-K-F-4B-C	Performed by	Jeremy Luong

Above 1GHz Plots for Transmit Mode at 5500 MHz

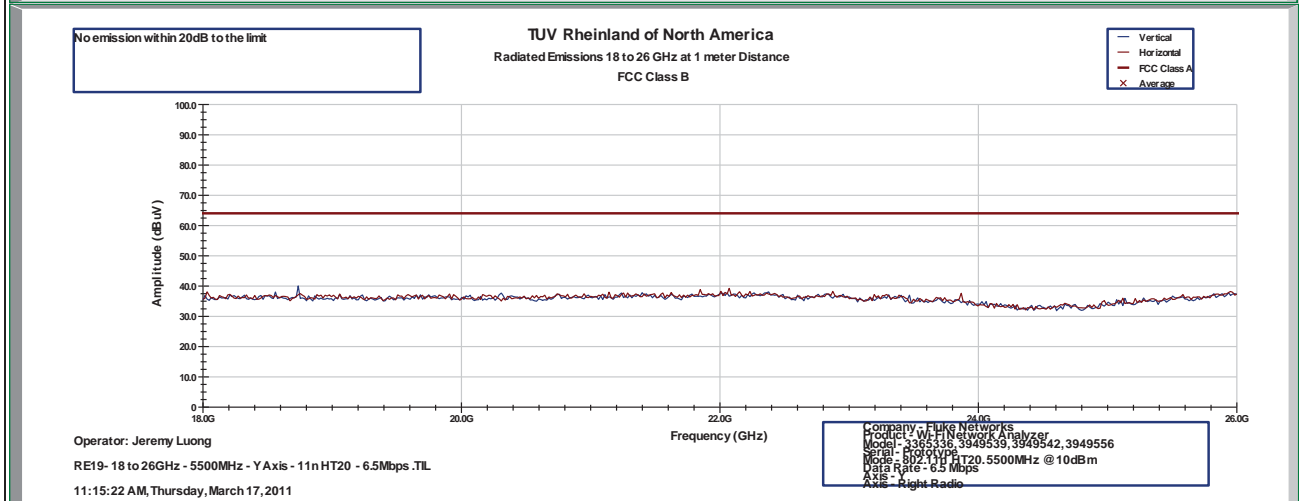
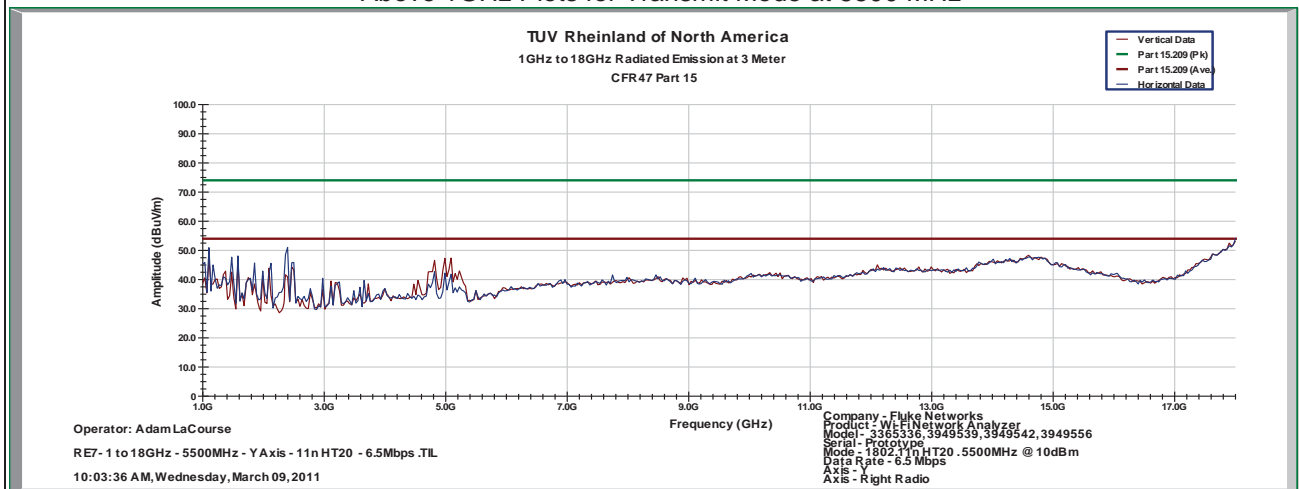

Notes: Limit was extrapolated to 1m distance for 18GHz – 40 GHz range.

SOP 1 Radiated Emissions

Tracking # 31053887.002 Page 17 of 21

EUT Name	OPTIVIEW XG, OPVXG, OPTIVIEW XG-10G, OPVXG-10G, OPVXGPRO, OPVXG-EXPT, OPTIVIEW XG-LAN, OPVXG-LAN, OPVXG-LAN-10G, OPTIVIEW XG WLAN, OPVXG-WLAN	Date	March 18, 2011
EUT Model	3365336, 3949539, 3949542, 3949556, 3949616, 4020634	Temp / Hum in	22°C / 39%rh
EUT Serial	Prototype	Temp / Hum out	N/A
EUT Config.	Y-Axis, 802.11n HT20 at 6.5Mbps	Line AC	120Vac 60Hz
Standard	CFR47 Part 15 Subpart C	RBW / VBW	1 MHz / 3MHz
Dist/Ant Used	1m - RA42-K-F-4B-C	Performed by	Jeremy Luong

Above 1GHz Plots for Transmit Mode at 5500 MHz

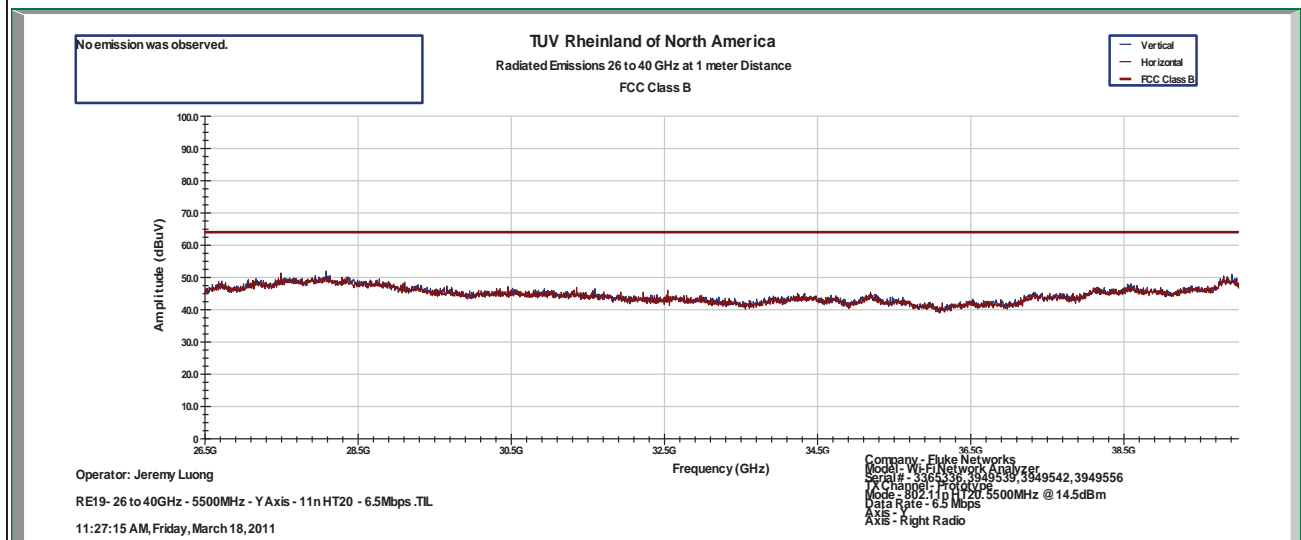

Notes: Limit was extrapolated to 1m distance for 18GHz – 40 GHz range.

SOP 1 Radiated Emissions

Tracking # 31053887.002 Page 18 of 21

EUT Name	OPTIVIEW XG, OPVXG, OPTIVIEW XG-10G, OPVXG-10G, OPVXGPRO, OPVXG-EXPT, OPTIVIEW XG-LAN, OPVXG-LAN, OPVXG-LAN-10G, OPTIVIEW XG WLAN, OPVXG-WLAN	Date	March 17, 2011
EUT Model	3365336, 3949539, 3949542, 3949556, 3949616, 4020634	Temp / Hum in	23°C / 39%rh
EUT Serial	Prototype	Temp / Hum out	N/A
EUT Config.	Y-Axis, 802.11n HT20 at 6.5Mbps	Line AC	120Vac 60Hz
Standard	CFR47 Part 15 Subpart C	RBW / VBW	1 MHz / 3MHz
Dist/Ant Used	3m - EMCO3115 / 1m - RA42-K-F-4B-C	Performed by	Jeremy Luong

Above 1GHz Plots for Transmit Mode at 5600 MHz

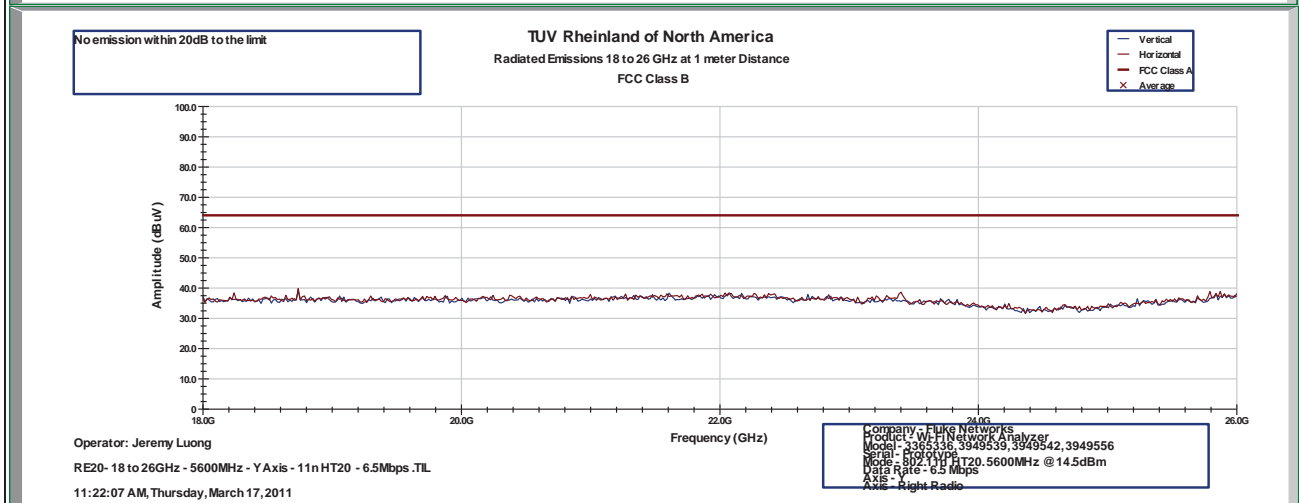
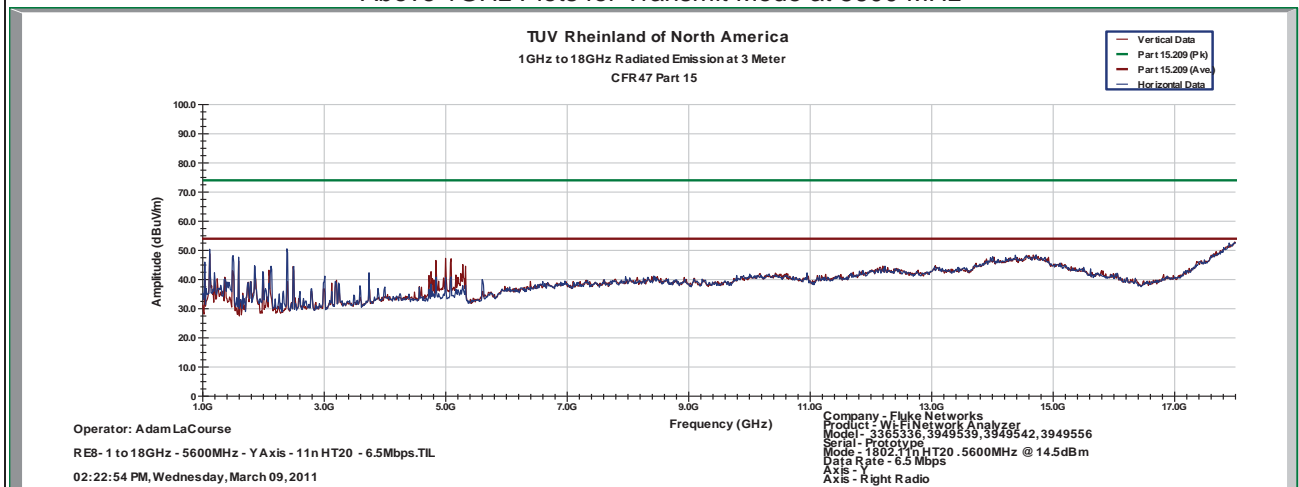

Notes: Limit was extrapolated to 1m distance for 18GHz – 40 GHz range.

SOP 1 Radiated Emissions Tracking # 31053887.002 Page 19 of 21

EUT Name	OPTIVIEW XG, OPVXG, OPTIVIEW XG-10G, OPVXG-10G, OPVXGPRO, OPVXG-EXPT, OPTIVIEW XG-LAN, OPVXG-LAN, OPVXG-LAN-10G, OPTIVIEW XG WLAN, OPVXG-WLAN	Date	March 18, 2011
EUT Model	3365336, 3949539, 3949542, 3949556, 3949616, 4020634	Temp / Hum in	22°C / 39%rh
EUT Serial	Prototype	Temp / Hum out	N/A
EUT Config.	Y-Axis, 802.11n HT20 at 6.5Mbps	Line AC	120Vac 60Hz
Standard	CFR47 Part 15 Subpart C	RBW / VBW	1 MHz / 3MHz
Dist/Ant Used	1m - RA42-K-F-4B-C	Performed by	Jeremy Luong

Above 1GHz Plots for Transmit Mode at 5600 MHz

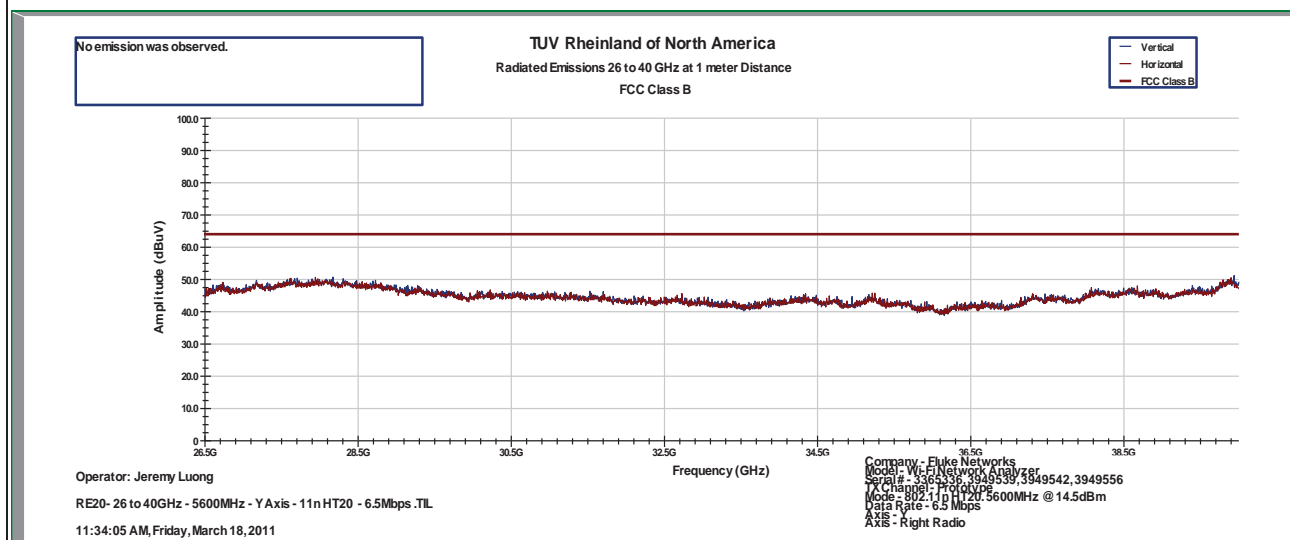

Notes: Limit was extrapolated to 1m distance for 18GHz – 40 GHz range.
 1GHz – 25 GHz Setting: RBW = 1 MHz/ VBW = 3MHz

SOP 1 Radiated Emissions

Tracking # 31053887.002 Page 20 of 21

EUT Name	OPTIVIEW XG, OPVXG, OPTIVIEW XG-10G, OPVXG-10G, OPVXGPRO, OPVXG-EXPT, OPTIVIEW XG-LAN, OPVXG-LAN, OPVXG-LAN-10G, OPTIVIEW XG WLAN, OPVXG-WLAN	Date	March 17, 2011
EUT Model	3365336, 3949539, 3949542, 3949556, 3949616, 4020634	Temp / Hum in	23°C / 39%rh
EUT Serial	Prototype	Temp / Hum out	N/A
EUT Config.	Y-Axis, 802.11n HT20 at 6.5Mbps	Line AC	120Vac 60Hz
Standard	CFR47 Part 15 Subpart C	RBW / VBW	1 MHz / 3MHz
Dist/Ant Used	3m - EMCO3115 / 1m - RA42-K-F-4B-C	Performed by	Jeremy Luong

Above 1GHz Plots for Transmit Mode at 5700 MHz

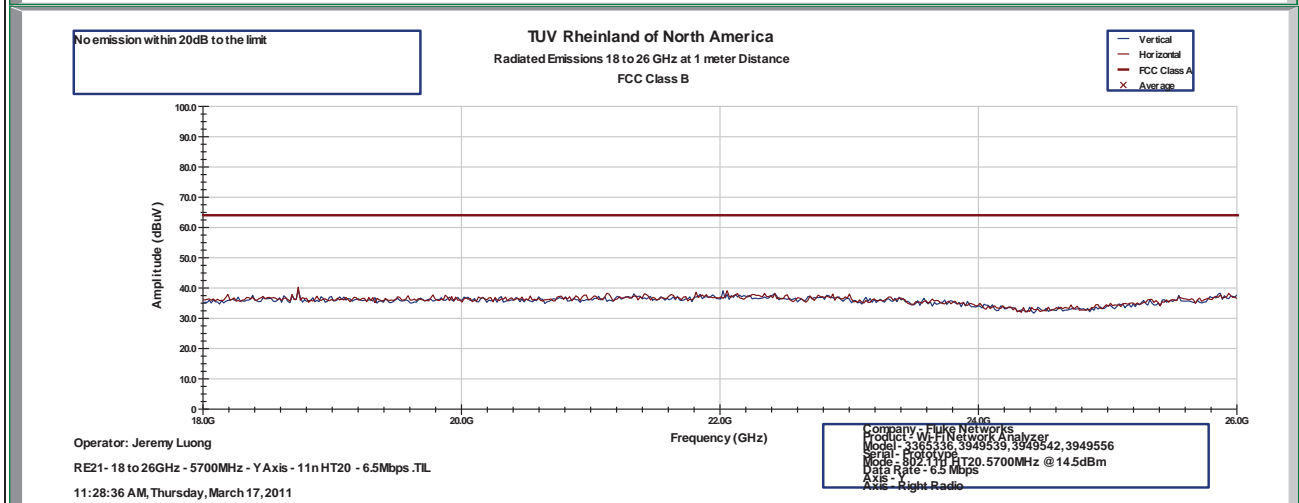
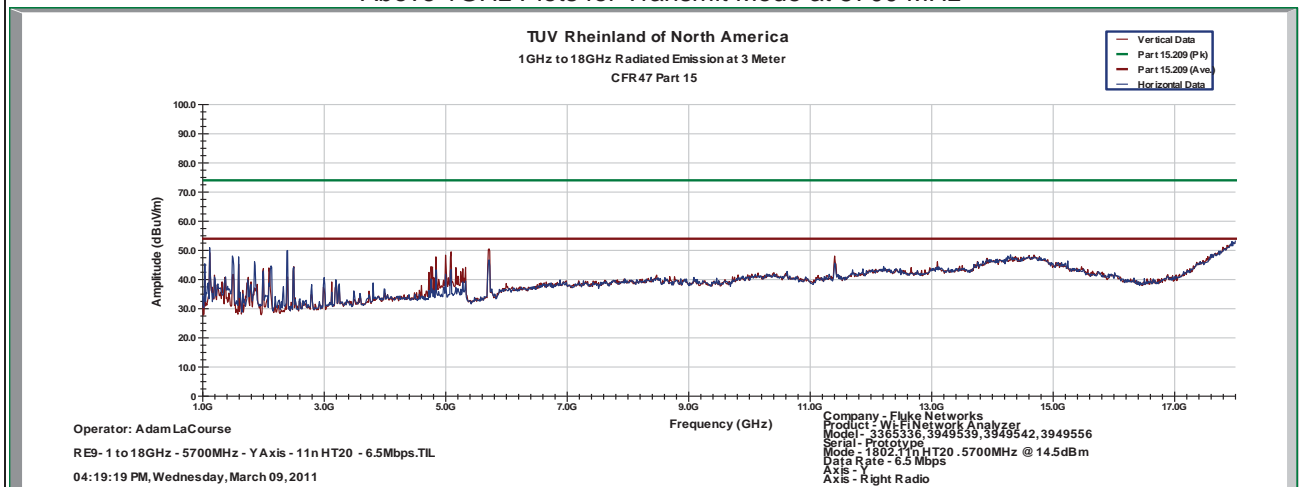

Notes: Limit was extrapolated to 1m distance for 18GHz – 40 GHz range.

SOP 1 Radiated Emissions

Tracking # 31053887.002 Page 21 of 21

EUT Name	OPTIVIEW XG, OPVXG, OPTIVIEW XG-10G, OPVXG-10G, OPVXGPRO, OPVXG-EXPT, OPTIVIEW XG-LAN, OPVXG-LAN, OPVXG-LAN-10G, OPTIVIEW XG WLAN, OPVXG-WLAN	Date	March 18, 2011
EUT Model	3365336, 3949539, 3949542, 3949556, 3949616, 4020634	Temp / Hum in	22°C / 39%rh
EUT Serial	Prototype	Temp / Hum out	N/A
EUT Config.	Y-Axis, 802.11n HT20 at 6.5Mbps	Line AC	120Vac 60Hz
Standard	CFR47 Part 15 Subpart C	RBW / VBW	1 MHz / 3MHz
Dist/Ant Used	1m - RA42-K-F-4B-C	Performed by	Jeremy Luong

Above 1GHz Plots for Transmit Mode at 5700 MHz

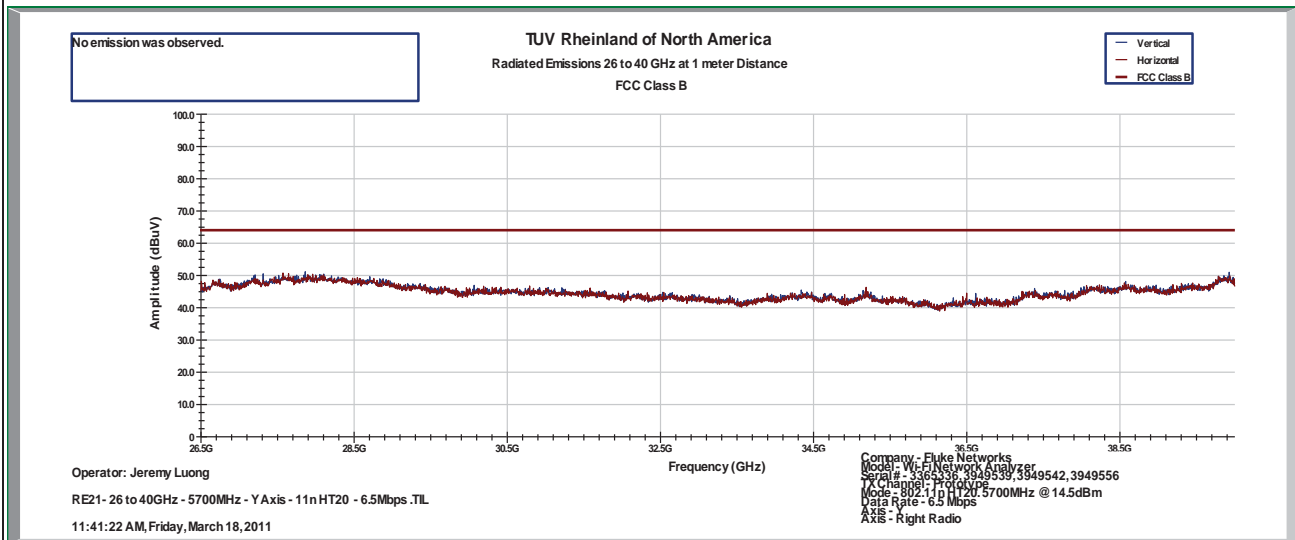

Notes: Limit was extrapolated to 1m distance for 18GHz – 40 GHz range.

SOP 1 Radiated Emissions											Tracking # 31053887.002 Page 1 of 16	
EUT Name		OPTIVIEW XG, OPVXG, OPTIVIEW XG-10G, OPVXG-10G, OPVXGPRO, OPVXG-EXPT, OPTIVIEW XG-LAN, OPVXG-LAN, OPVXG-LAN-10G, OPTIVIEW XG WLAN, OPVXG-WLAN						Date		March 11, 2011		
EUT Model		3365336, 3949539, 3949542, 3949556, 3949616, 4020634						Temp / Hum in		23°C / 39%rh		
EUT Serial		Prototype						Temp / Hum out		N/A		
EUT Config.		Y-Axis, 802.11n HT40 at 40.5Mbps						Line AC / Freq		120Vac/60Hz		
Standard		CFR47 Part 15 Subpart C						RBW / VBW		1 MHz/ 3 MHz		
Dist/Ant Used		3m / EMCO3115 / 1m - RA42-K-F-4B-C						Performed by		Jeremy Luong		
Emission Freq (MHz)	ANT Polar (H/V)	ANT Pos (cm)	Table Pos (deg)	FIM (Pk) (dBuV/m)	FIM Ave (dBuV/m)	Total CF (dBuV)	E-Field Ave (dBuV/m)	Spec Limit (dBuV/m)	Spec Margin (dB)	Type		
Transmitted Data at 5190 MHz @ 11 dBm												
1200.03	H	181	154	69.25	53.91	-8.00	45.91	53.98	-8.07	Spurious		
1595.32	H	191	254	62.36	41.48	-6.83	34.65	53.98	-19.33	Spurious		
1861.17	H	137	205	60.34	46.47	-4.94	41.53	53.98	-12.45	Spurious		
5000.02	V	190	153	44.16	36.47	2.84	39.31	53.98	-14.67	Spurious		
10390.00	V	137	135	36.81	22.89	11.80	34.69	53.98	-19.29	Harmonic		
10390.00	H	128	70	34.67	19.88	11.80	31.68	53.98	-22.30	Harmonic		
Transmitted Data at 5230 MHz @ 11 dBm												
1200.08	H	202	385	53.44	46.91	-8.00	38.91	53.98	-15.07	Spurious		
1861.15	H	139	202	59.69	46.36	-4.94	41.42	53.98	-12.56	Spurious		
2393.26	H	191	126	57.31	36.79	-3.00	33.79	53.98	-20.19	Spurious		
4840.00	V	179	143	49.21	44.69	2.50	47.19	53.98	-6.79	Spurious		
10458.20	V	182	157	37.88	22.82	11.85	34.67	53.98	-19.31	Harmonic		
10460.50	H	126	129	37.06	22.88	11.85	34.73	53.98	-19.25	Harmonic		
Transmitted Data at 5270 MHz @ 13.5dBm												
1200.05	H	208	151	59.55	42.61	-8.00	34.61	53.98	-19.37	Spurious		
1595.50	H	193	242	60.57	41.32	-6.83	34.49	53.98	-19.49	Spurious		
1861.24	H	138	198	60.44	46.48	-4.94	41.54	53.98	-12.44	Spurious		
2392.83	H	247	124	56.97	36.08	-3.01	33.07	53.98	-20.91	Spurious		
4840.03	V	137	68	47.57	42.60	2.50	45.10	53.98	-8.88	Spurious		
10542.60	V	137	-29	34.28	22.74	11.77	34.51	53.98	-19.47	Harmonic		
10538.80	H	214	307	36.47	22.52	11.79	34.31	53.98	-19.67	Harmonic		
Spec Margin = E-Field QP - Limit, E-Field QP = FIM QP+ Total CF ± Uncertainty												
Total CF= Amp Gain + Cable Loss + ANT Factor												
Combined Standard Uncertainty $u_c(y) = \pm 3.2$ dB Expanded Uncertainty $U = k u_c(y)$ $k = 2$ for 95% confidence												
Notes: Worst case was observed on Y-axis, 40.5Mbps, 3 streams.												

SOP 1 Radiated Emissions							Tracking # 31053887.002 Page 2 of 16			
EUT Name	OPTIVIEW XG, OPVXG, OPTIVIEW XG-10G, OPVXG-10G, OPVXGPRO, OPVXG-EXPT, OPTIVIEW XG-LAN, OPVXG-LAN, OPVXG-LAN-10G, OPTIVIEW XG WLAN, OPVXG-WLAN					Date	March 11, 2011			
EUT Model	3365336, 3949539, 3949542, 3949556, 3949616, 4020634					Temp / Hum in	23°C / 39%rh			
EUT Serial	Prototype					Temp / Hum out	N/A			
EUT Config.	Y-Axis, 802.11n HT40 at 40.5Mbps					Line AC / Freq	120Vac/60Hz			
Standard	CFR47 Part 15 Subpart C					RBW / VBW	1 MHz/ 3 MHz			
Dist/Ant Used	3m / EMCO3115 / 1m - RA42-K-F-4B-C					Performed by	Jeremy Luong			
Emission Freq (MHz)	ANT Polar (H/V)	ANT Pos (cm)	Table Pos (deg)	FIM (Pk) (dBuV/m)	FIM Ave (dBuV/m)	Total CF (dBuV)	E-Field Ave (dBuV/m)	Spec Limit (dBuV/m)	Spec Margin (dB)	Type
Transmitted Data at 5310 MHz @ 13.5dBm										
1199.99	H	191	155	60.52	41.97	-8.00	33.97	53.98	-20.01	Spurious
1595.23	H	190	248	62.11	41.59	-6.83	34.76	53.98	-19.22	Spurious
1861.09	H	137	204	60.54	46.72	-4.94	41.78	53.98	-12.20	Spurious
2393.13	H	148	124	58.40	36.68	-3.00	33.68	53.98	-20.30	Spurious
4840.05	V	216	138	49.10	44.83	2.50	47.33	53.98	-6.65	Spurious
10624.90	V	159	144	35.74	22.47	11.82	34.29	53.98	-19.69	Harmonic
10618.90	H	103	162	35.56	22.47	11.82	34.29	53.98	-19.69	Harmonic
Transmitted Data at 5510 MHz @ 10 dBm										
1200.08	H	185	-2	54.63	46.75	-8.00	38.75	53.98	-15.23	Spurious
1598.02	H	190	252	61.60	41.68	-6.82	34.86	53.98	-19.12	Spurious
1861.23	H	186	230	59.54	45.82	-4.94	40.88	53.98	-13.10	Spurious
2393.03	H	190	125	58.45	37.09	-3.00	34.09	53.98	-19.89	Spurious
4800.00	V	156	98	46.21	40.55	2.30	42.85	53.98	-11.13	Spurious
11022.40	V	159	208	35.90	21.96	11.70	33.66	53.98	-20.32	Harmonic
11019.60	H	150	419	34.97	21.73	11.71	33.44	53.98	-20.54	Harmonic
Transmitted Data at 5590 MHz @ 12.5dBm										
1200.10	H	191	13	54.02	48.98	-8.00	40.98	53.98	-13.00	Spurious
1595.55	H	192	-89	61.05	40.70	-6.83	33.87	53.98	-20.11	Spurious
1861.15	H	138	201	60.16	46.62	-4.94	41.68	53.98	-12.30	Spurious
2392.97	H	151	125	58.88	36.99	-3.00	33.99	53.98	-19.99	Spurious
4800.00	V	222	140	44.94	38.31	2.30	40.61	53.98	-13.37	Spurious
11181.50	H	125	185	34.86	22.33	11.80	34.13	53.98	-19.85	Harmonic
11179.90	V	153	100	36.20	22.16	11.80	33.96	53.98	-20.02	Harmonic
Transmitted Data at 5670 MHz @ 12.5dBm										
1199.90	H	200	165	58.76	39.71	-8.00	31.71	53.98	-22.27	Spurious
1595.37	H	191	246	62.13	42.07	-6.83	35.24	53.98	-18.74	Spurious
1861.09	H	139	204	60.24	46.99	-4.94	42.05	53.98	-11.93	Spurious
2393.15	H	193	127	57.21	37.25	-3.00	34.25	53.98	-19.73	Spurious
4800.00	V	197	116	46.31	39.08	2.30	41.39	53.98	-12.59	Spurious
11342.70	V	179	147	35.52	21.25	11.84	33.09	53.98	-20.89	Harmonic
11344.00	H	142	140	33.54	21.15	11.84	32.99	53.98	-20.99	Harmonic

Spec Margin = E-Field QP - Limit, E-Field QP = FIM QP+ Total CF \pm Uncertainty

Total CF= Amp Gain + Cable Loss + ANT Factor

Combined Standard Uncertainty $u_c(y) = \pm 3.2$ dB Expanded Uncertainty $U = k u_c(y)$ $k = 2$ for 95% confidence

Notes: Worst case was observed on Y-axis, 40.5Mbps, 3 streams.

SOP 1 Radiated Emissions

Tracking # 31053887.002 Page 3 of 16

EUT Name	OPTIVIEW XG, OPVXG, OPTIVIEW XG-10G, OPVXG-10G, OPVXGPRO, OPVXG-EXPT, OPTIVIEW XG-LAN, OPVXG-LAN, OPVXG-LAN-10G, OPTIVIEW XG WLAN, OPVXG-WLAN	Date	March 11, 2011
EUT Model	3365336, 3949539, 3949542, 3949556, 3949616, 4020634	Temp / Hum in	23°C / 39%rh
EUT Serial	Prototype	Temp / Hum out	N/A
EUT Config.	Y-Axis, 802.11n HT40 at 40.5Mbps	Line AC	120Vac 60Hz
Standard	CFR47 Part 15 Subpart C	RBW / VBW	1 MHz / 3MHz
Dist/Ant Used	3m - EMCO3115 / 1m - RA42-K-F-4B-C	Performed by	Jeremy Luong

Above 1GHz Plots for Transmit Mode at 5190 MHz

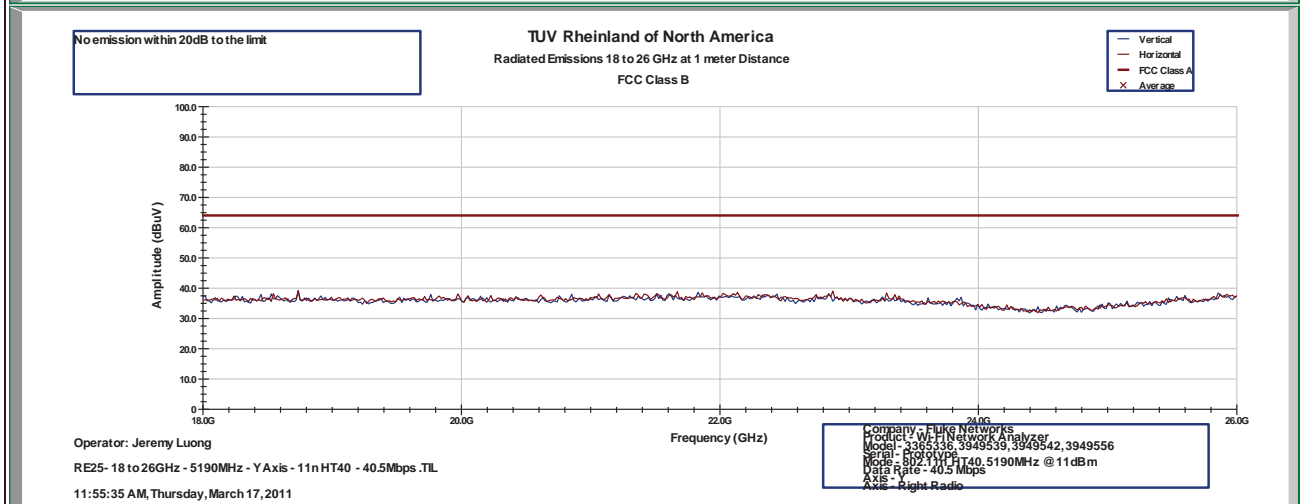
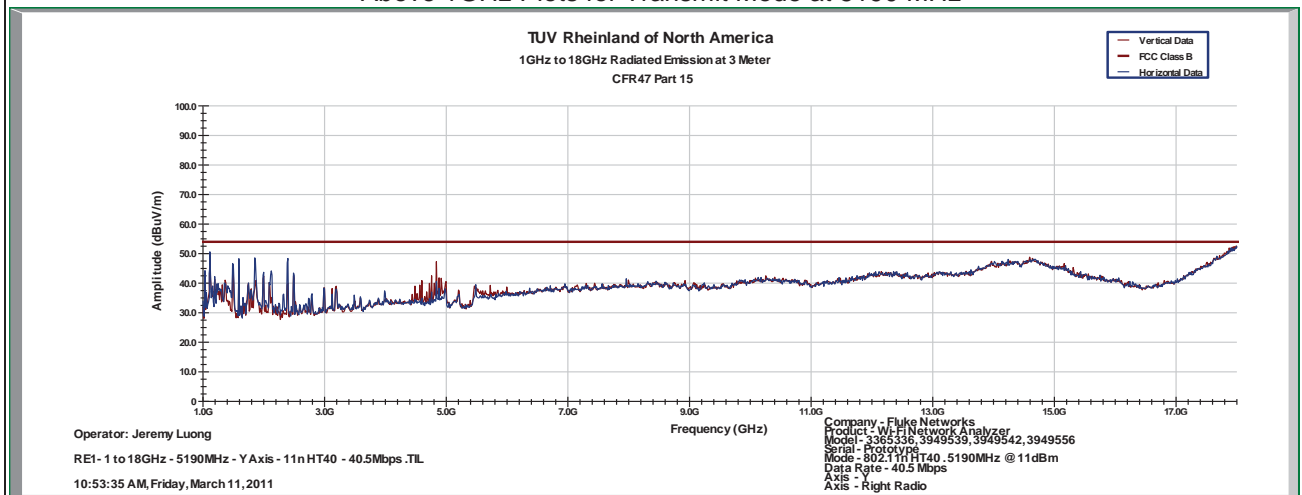

Notes: Limit was extrapolated to 1m distance for 18GHz – 40 GHz range.

SOP 1 Radiated Emissions

Tracking # 31053887.002 Page 4 of 16

EUT Name	OPTIVIEW XG, OPVXG, OPTIVIEW XG-10G, OPVXG-10G, OPVXGPRO, OPVXG-EXPT, OPTIVIEW XG-LAN, OPVXG-LAN, OPVXG-LAN-10G, OPTIVIEW XG WLAN, OPVXG-WLAN	Date	March 18, 2011
EUT Model	3365336, 3949539, 3949542, 3949556, 3949616, 4020634	Temp / Hum in	22°C / 39%rh
EUT Serial	Prototype	Temp / Hum out	N/A
EUT Config.	Y-Axis, 802.11n HT40 at 40.5Mbps	Line AC	120Vac 60Hz
Standard	CFR47 Part 15 Subpart C	RBW / VBW	1 MHz / 3MHz
Dist/Ant Used	1m - RA42-K-F-4B-C	Performed by	Jeremy Luong

Above 1GHz Plots for Transmit Mode at 5190 MHz

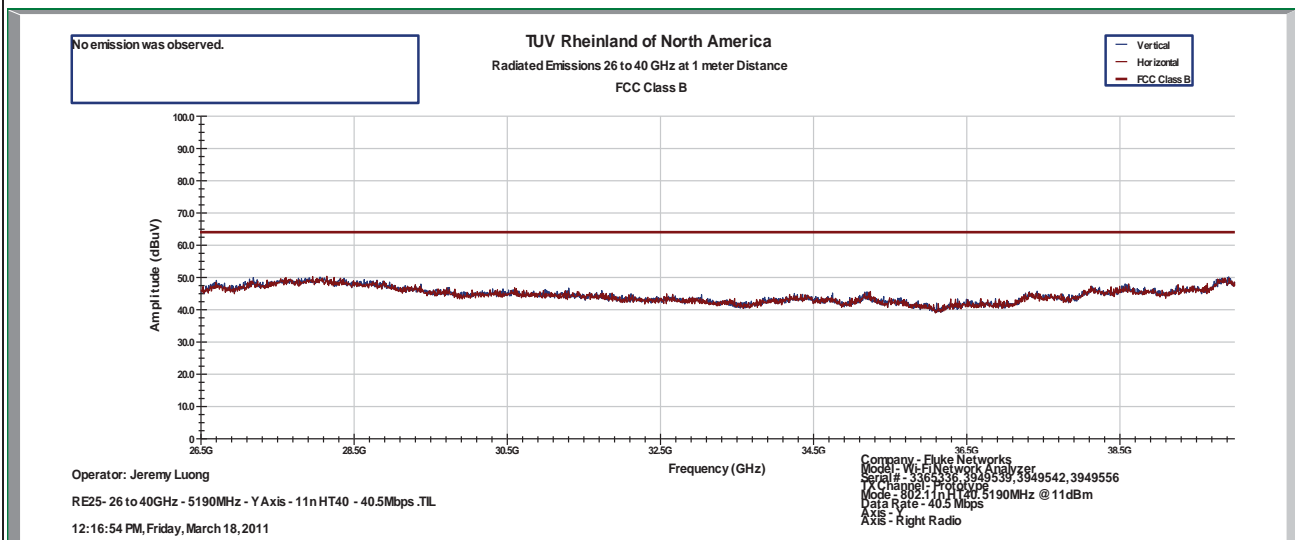

Notes: Limit was extrapolated to 1m distance for 18GHz – 40 GHz range.
 1GHz – 25 GHz Setting: RBW = 1 MHz/ VBW = 3MHz

SOP 1 Radiated Emissions

Tracking # 31053887.002 Page 5 of 16

EUT Name	OPTIVIEW XG, OPVXG, OPTIVIEW XG-10G, OPVXG-10G, OPVXGPRO, OPVXG-EXPT, OPTIVIEW XG-LAN, OPVXG-LAN, OPVXG-LAN-10G, OPTIVIEW XG WLAN, OPVXG-WLAN	Date	March 17, 2011
EUT Model	3365336, 3949539, 3949542, 3949556, 3949616, 4020634	Temp / Hum in	23°C / 39%rh
EUT Serial	Prototype	Temp / Hum out	N/A
EUT Config.	Y-Axis, 802.11n HT40 at 40.5Mbps	Line AC	120Vac 60Hz
Standard	CFR47 Part 15 Subpart C	RBW / VBW	1 MHz / 3MHz
Dist/Ant Used	3m - EMCO3115 / 1m - RA42-K-F-4B-C	Performed by	Jeremy Luong

Above 1GHz Plots for Transmit Mode at 5230 MHz

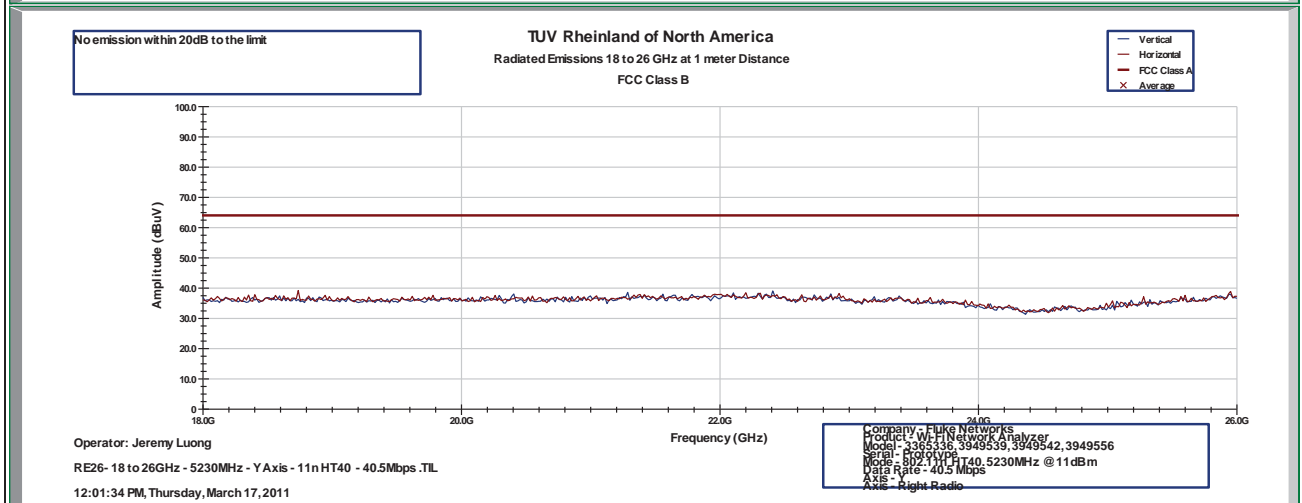
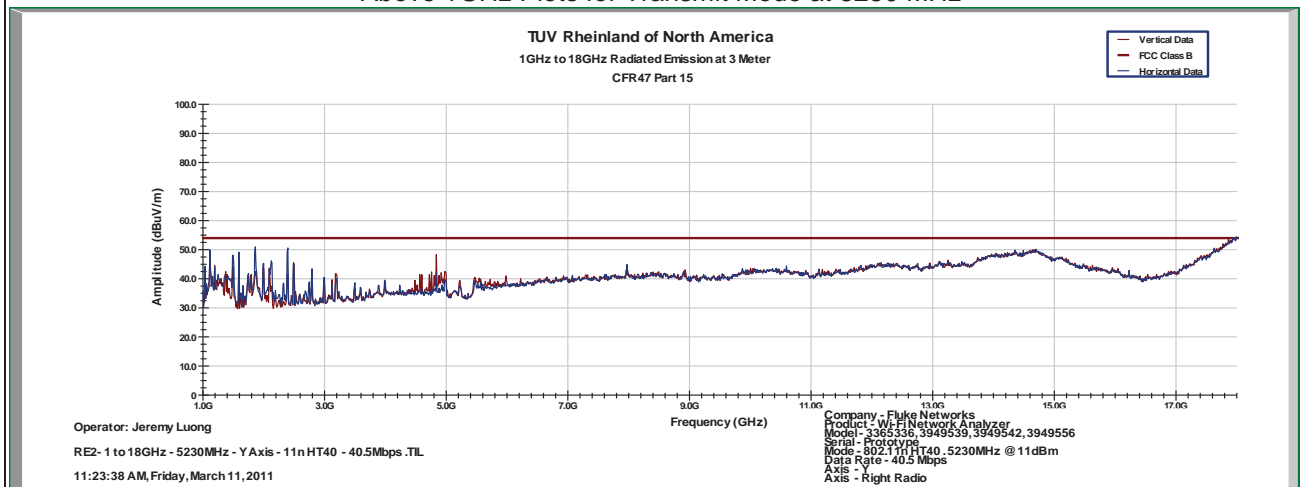

Notes: Limit was extrapolated to 1m distance for 18GHz – 40 GHz range.

SOP 1 Radiated Emissions

Tracking # 31053887.002 Page 6 of 16

EUT Name	OPTIVIEW XG, OPVXG, OPTIVIEW XG-10G, OPVXG-10G, OPVXGPRO, OPVXG-EXPT, OPTIVIEW XG-LAN, OPVXG-LAN, OPVXG-LAN-10G, OPTIVIEW XG WLAN, OPVXG-WLAN	Date	March 18, 2011
EUT Model	3365336, 3949539, 3949542, 3949556, 3949616, 4020634	Temp / Hum in	22°C / 39%rh
EUT Serial	Prototype	Temp / Hum out	N/A
EUT Config.	Y-Axis, 802.11n HT40 at 40.5Mbps	Line AC	120Vac 60Hz
Standard	CFR47 Part 15 Subpart C	RBW / VBW	1 MHz / 3MHz
Dist/Ant Used	1m - RA42-K-F-4B-C	Performed by	Jeremy Luong

Above 1GHz Plots for Transmit Mode at 5230 MHz

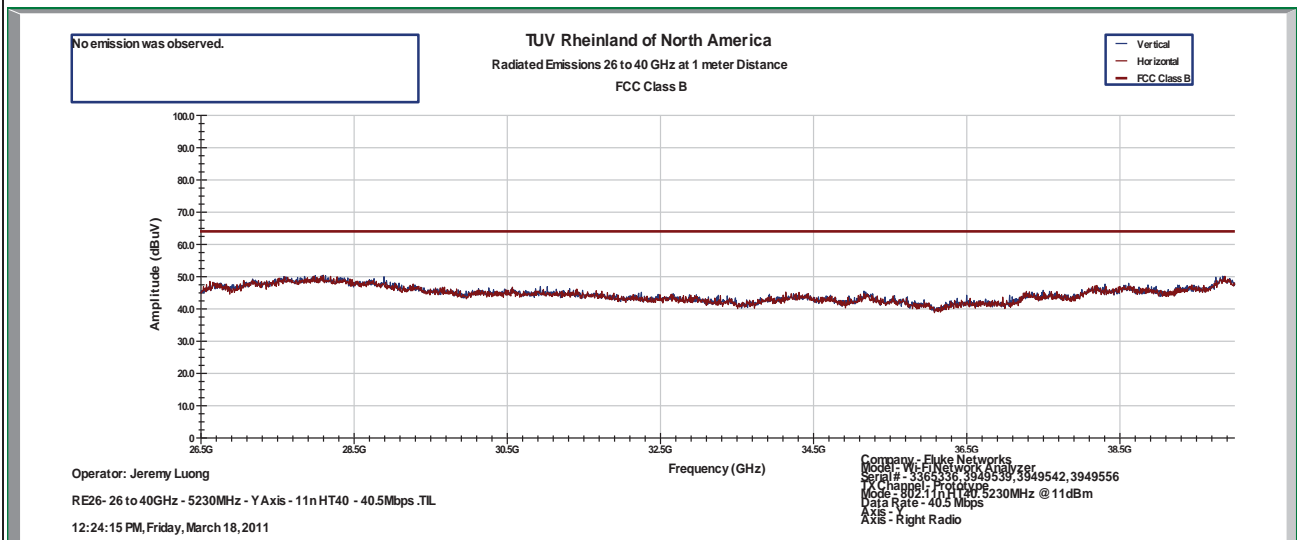

Notes: Limit was extrapolated to 1m distance for 18GHz – 40 GHz range.
 1GHz – 25 GHz Setting: RBW = 1 MHz/ VBW = 3MHz

SOP 1 Radiated Emissions

Tracking # 31053887.002 Page 7 of 16

EUT Name	OPTIVIEW XG, OPVXG, OPTIVIEW XG-10G, OPVXG-10G, OPVXGPRO, OPVXG-EXPT, OPTIVIEW XG-LAN, OPVXG-LAN, OPVXG-LAN-10G, OPTIVIEW XG WLAN, OPVXG-WLAN	Date	March 11, 2011
EUT Model	3365336, 3949539, 3949542, 3949556, 3949616, 4020634	Temp / Hum in	23°C / 39%rh
EUT Serial	Prototype	Temp / Hum out	N/A
EUT Config.	Y-Axis, 802.11n HT40 at 40.5Mbps	Line AC	120Vac 60Hz
Standard	CFR47 Part 15 Subpart C	RBW / VBW	1 MHz / 3MHz
Dist/Ant Used	3m - EMCO3115 / 1m - RA42-K-F-4B-C	Performed by	Jeremy Luong

Above 1GHz Plots for Transmit Mode at 5270 MHz

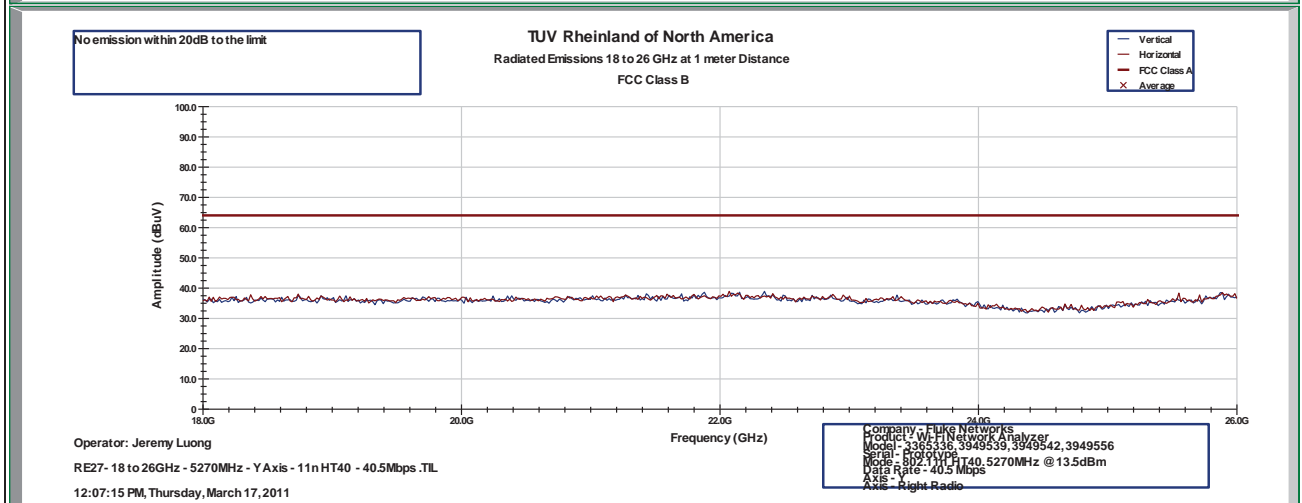
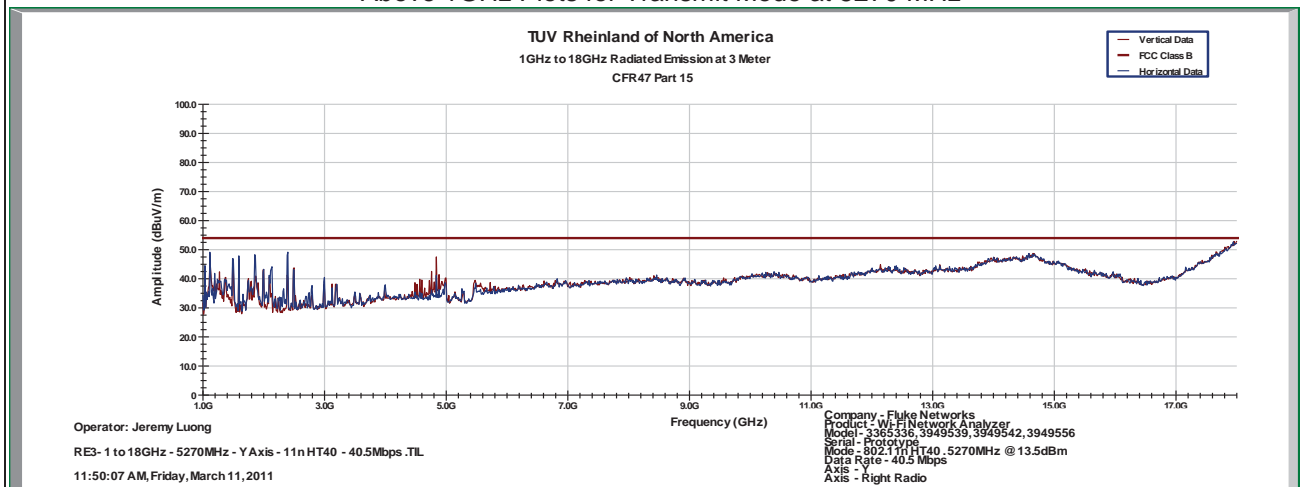

Notes: Limit was extrapolated to 1m distance for 18GHz – 40 GHz range.

SOP 1 Radiated Emissions

Tracking # 31053887.002 Page 8 of 16

EUT Name	OPTIVIEW XG, OPVXG, OPTIVIEW XG-10G, OPVXG-10G, OPVXGPRO, OPVXG-EXPT, OPTIVIEW XG-LAN, OPVXG-LAN, OPVXG-LAN-10G, OPTIVIEW XG WLAN, OPVXG-WLAN	Date	March 18, 2011
EUT Model	3365336, 3949539, 3949542, 3949556, 3949616, 4020634	Temp / Hum in	22°C / 39%rh
EUT Serial	Prototype	Temp / Hum out	N/A
EUT Config.	Y-Axis, 802.11n HT40 at 40.5Mbps	Line AC	120Vac 60Hz
Standard	CFR47 Part 15 Subpart C	RBW / VBW	1 MHz / 3MHz
Dist/Ant Used	1m - RA42-K-F-4B-C	Performed by	Jeremy Luong

Above 1GHz Plots for Transmit Mode at 5270 MHz

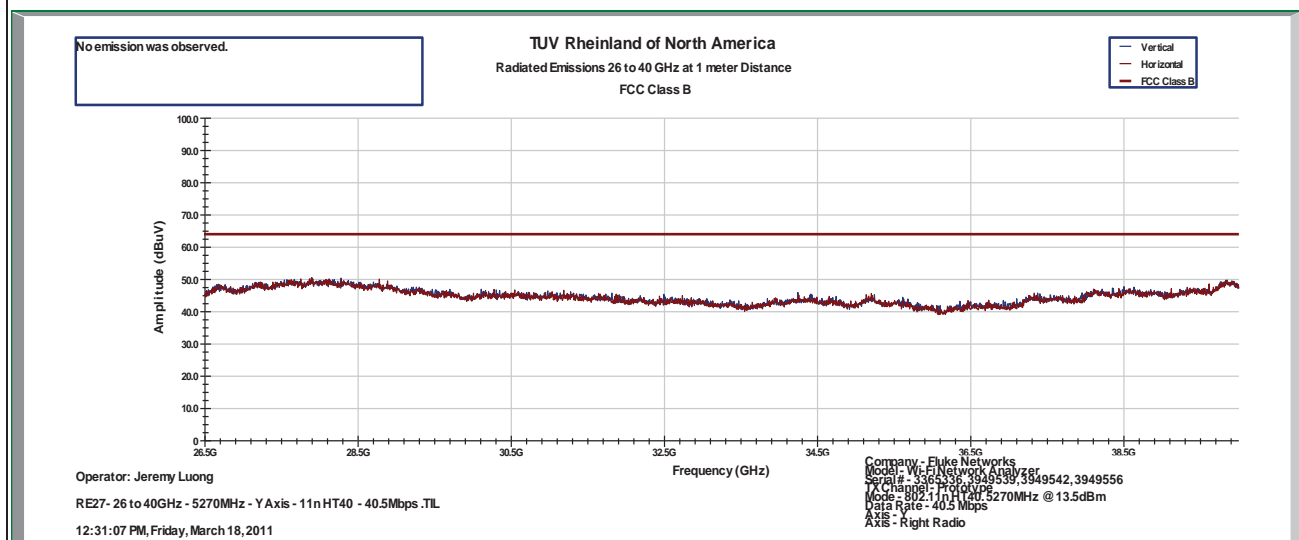

Notes: Limit was extrapolated to 1m distance for 18GHz – 40 GHz range.

SOP 1 Radiated Emissions

Tracking # 31053887.002 Page 9 of 16

EUT Name	OPTIVIEW XG, OPVXG, OPTIVIEW XG-10G, OPVXG-10G, OPVXGPRO, OPVXG-EXPT, OPTIVIEW XG-LAN, OPVXG-LAN, OPVXG-LAN-10G, OPTIVIEW XG WLAN, OPVXG-WLAN	Date	March 11, 2011
EUT Model	3365336, 3949539, 3949542, 3949556, 3949616, 4020634	Temp / Hum in	23°C / 39%rh
EUT Serial	Prototype	Temp / Hum out	N/A
EUT Config.	Y-Axis, 802.11n HT40 at 40.5Mbps	Line AC	120Vac 60Hz
Standard	CFR47 Part 15 Subpart C	RBW / VBW	1 MHz / 3MHz
Dist/Ant Used	3m - EMCO3115 / 1m - RA42-K-F-4B-C	Performed by	Jeremy Luong

Above 1GHz Plots for Transmit Mode at 5310 MHz

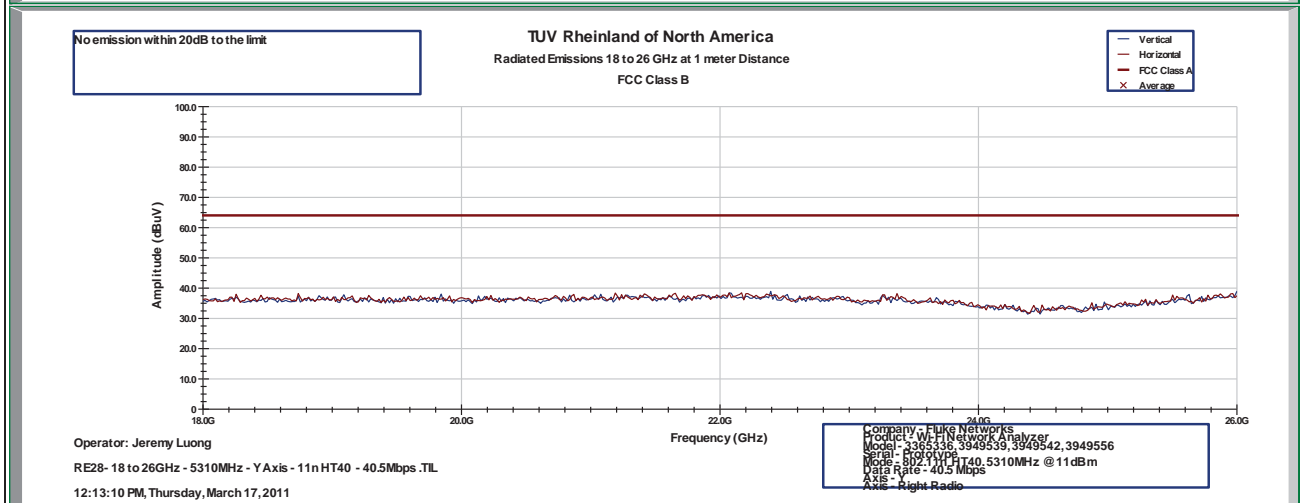
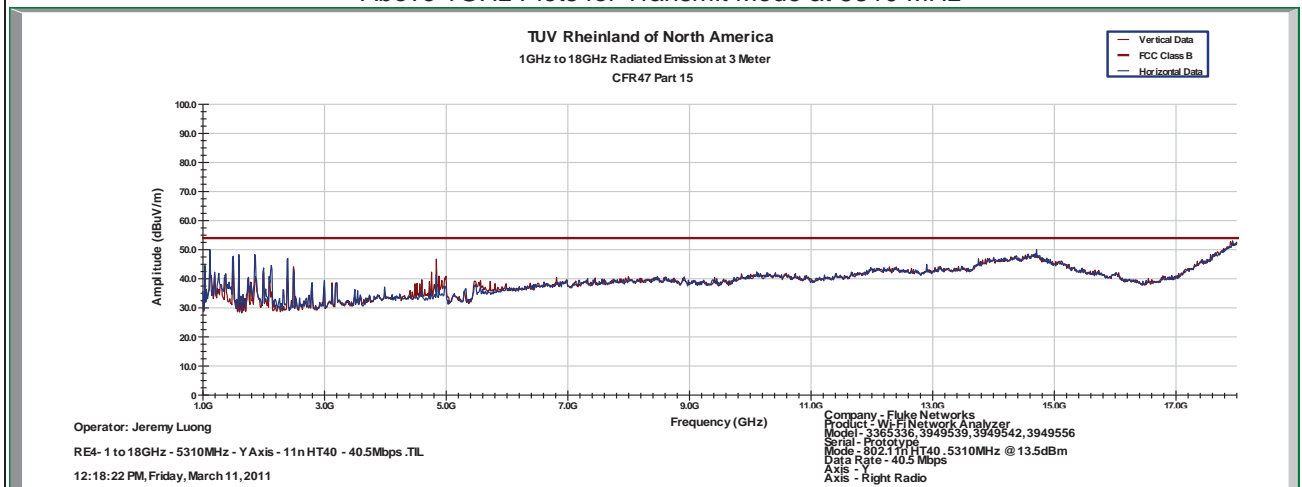

Notes: Limit was extrapolated to 1m distance for 18GHz – 40 GHz range.

SOP 1 Radiated Emissions

Tracking # 31053887.002 Page 10 of 16

EUT Name	OPTIVIEW XG, OPVXG, OPTIVIEW XG-10G, OPVXG-10G, OPVXGPRO, OPVXG-EXPT, OPTIVIEW XG-LAN, OPVXG-LAN, OPVXG-LAN-10G, OPTIVIEW XG WLAN, OPVXG-WLAN	Date	March 18, 2011
EUT Model	3365336, 3949539, 3949542, 3949556, 3949616, 4020634	Temp / Hum in	22°C / 39%rh
EUT Serial	Prototype	Temp / Hum out	N/A
EUT Config.	Y-Axis, 802.11n HT40 at 40.5Mbps	Line AC	120Vac 60Hz
Standard	CFR47 Part 15 Subpart C	RBW / VBW	1 MHz / 3MHz
Dist/Ant Used	1m - RA42-K-F-4B-C	Performed by	Jeremy Luong

Above 1GHz Plots for Transmit Mode at 5310 MHz

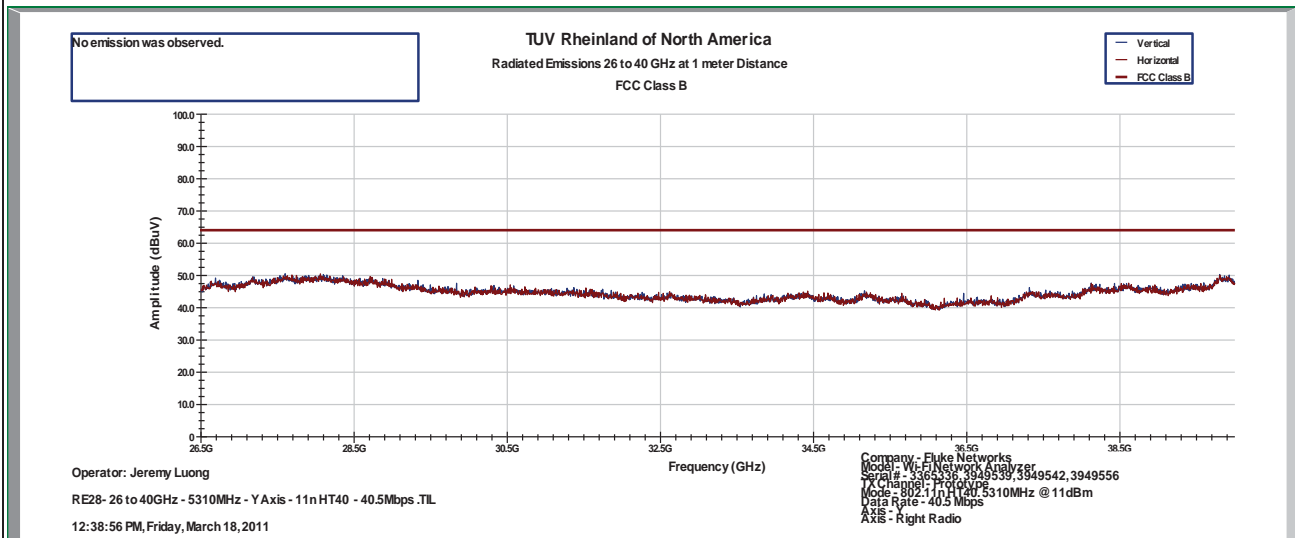

Notes: Limit was extrapolated to 1m distance for 18GHz – 40 GHz range.

SOP 1 Radiated Emissions

Tracking # 31053887.002 Page 11 of 16

EUT Name	OPTIVIEW XG, OPVXG, OPTIVIEW XG-10G, OPVXG-10G, OPVXGPRO, OPVXG-EXPT, OPTIVIEW XG-LAN, OPVXG-LAN, OPVXG-LAN-10G, OPTIVIEW XG WLAN, OPVXG-WLAN	Date	March 11, 2011
EUT Model	3365336, 3949539, 3949542, 3949556, 3949616, 4020634	Temp / Hum in	23°C / 39%rh
EUT Serial	Prototype	Temp / Hum out	N/A
EUT Config.	Y-Axis, 802.11n HT40 at 40.5Mbps	Line AC	120Vac 60Hz
Standard	CFR47 Part 15 Subpart C	RBW / VBW	1 MHz / 3MHz
Dist/Ant Used	3m - EMCO3115 / 1m - RA42-K-F-4B-C	Performed by	Jeremy Luong

Above 1GHz Plots for Transmit Mode at 5510 MHz

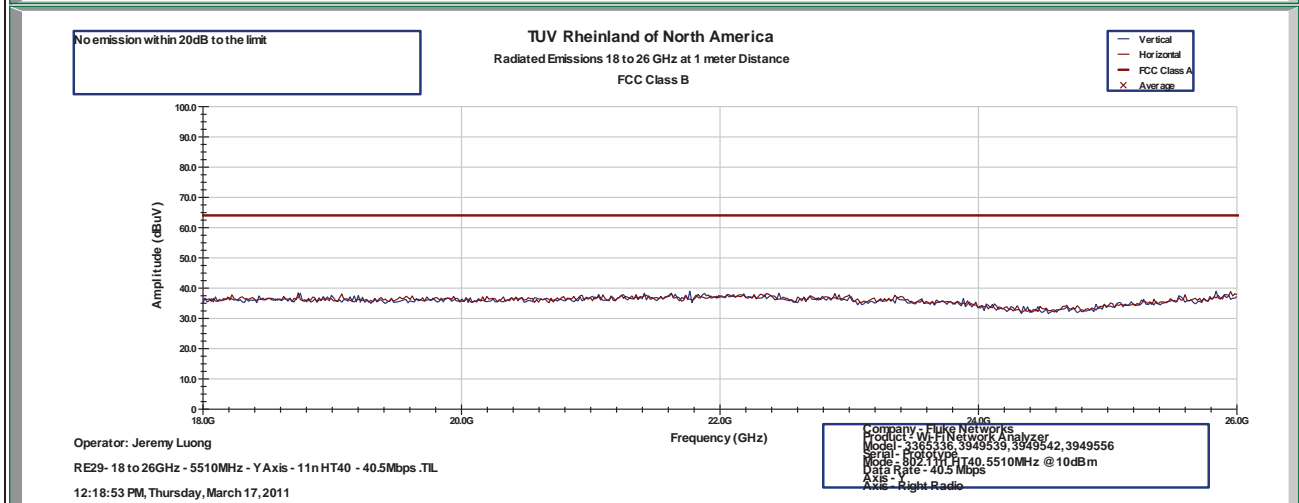
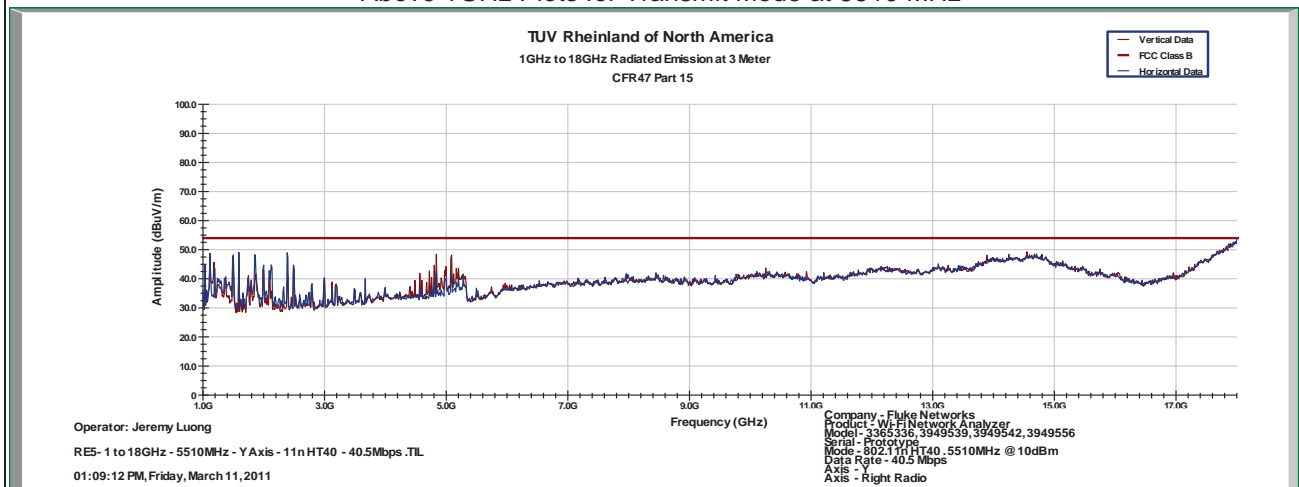

Notes: Limit was extrapolated to 1m distance for 18GHz – 40 GHz range.

SOP 1 Radiated Emissions

Tracking # 31053887.002 Page 12 of 16

EUT Name	OPTIVIEW XG, OPVXG, OPTIVIEW XG-10G, OPVXG-10G, OPVXGPRO, OPVXG-EXPT, OPTIVIEW XG-LAN, OPVXG-LAN, OPVXG-LAN-10G, OPTIVIEW XG WLAN, OPVXG-WLAN	Date	March 18, 2011
EUT Model	3365336, 3949539, 3949542, 3949556, 3949616, 4020634	Temp / Hum in	22°C / 39%rh
EUT Serial	Prototype	Temp / Hum out	N/A
EUT Config.	Y-Axis, 802.11n HT40 at 40.5Mbps	Line AC	120Vac 60Hz
Standard	CFR47 Part 15 Subpart C	RBW / VBW	1 MHz / 3MHz
Dist/Ant Used	1m - RA42-K-F-4B-C	Performed by	Jeremy Luong

Above 1GHz Plots for Transmit Mode at 5510 MHz

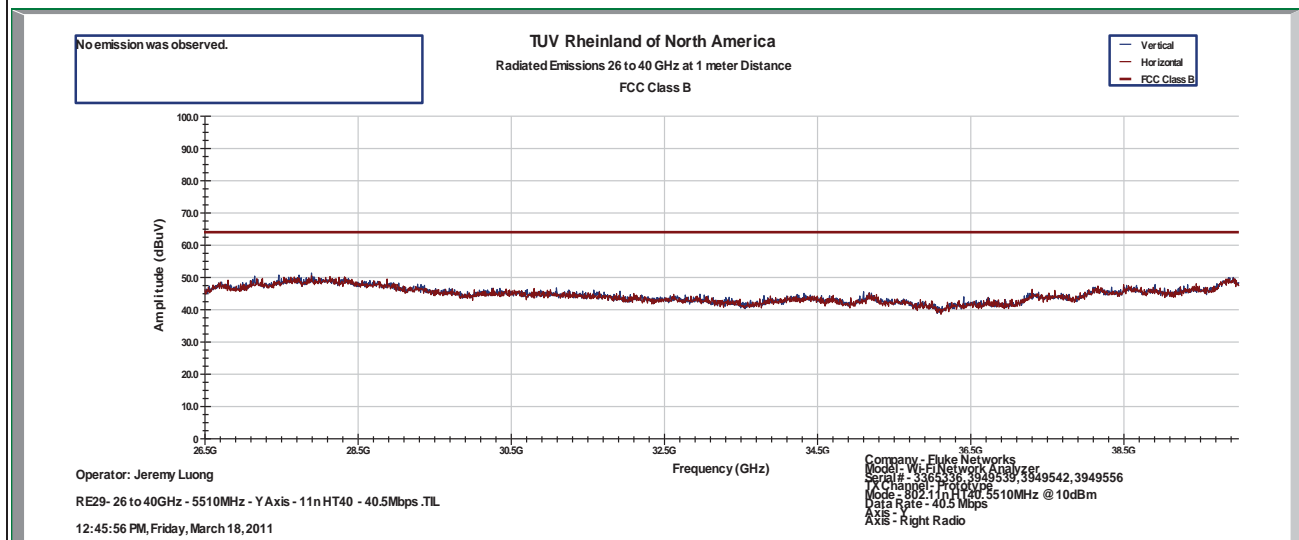

Notes: Limit was extrapolated to 1m distance for 18GHz – 40 GHz range.
 1GHz – 25 GHz Setting: RBW = 1 MHz/ VBW = 3MHz

SOP 1 Radiated Emissions

Tracking # 31053887.002 Page 13 of 16

EUT Name	OPTIVIEW XG, OPVXG, OPTIVIEW XG-10G, OPVXG-10G, OPVXGPRO, OPVXG-EXPT, OPTIVIEW XG-LAN, OPVXG-LAN, OPVXG-LAN-10G, OPTIVIEW XG WLAN, OPVXG-WLAN	Date	March 11, 2011
EUT Model	3365336, 3949539, 3949542, 3949556, 3949616, 4020634	Temp / Hum in	23°C / 39%rh
EUT Serial	Prototype	Temp / Hum out	N/A
EUT Config.	Y-Axis, 802.11n HT40 at 40.5Mbps	Line AC	120Vac 60Hz
Standard	CFR47 Part 15 Subpart C	RBW / VBW	1 MHz / 3MHz
Dist/Ant Used	3m - EMCO3115 / 1m - RA42-K-F-4B-C	Performed by	Jeremy Luong

Above 1GHz Plots for Transmit Mode at 5590 MHz

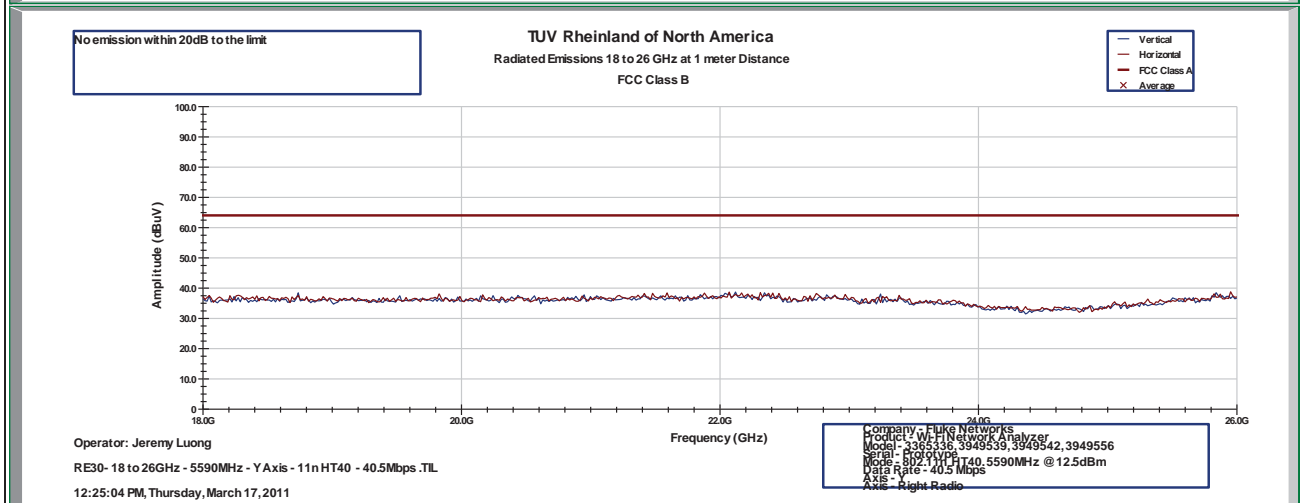
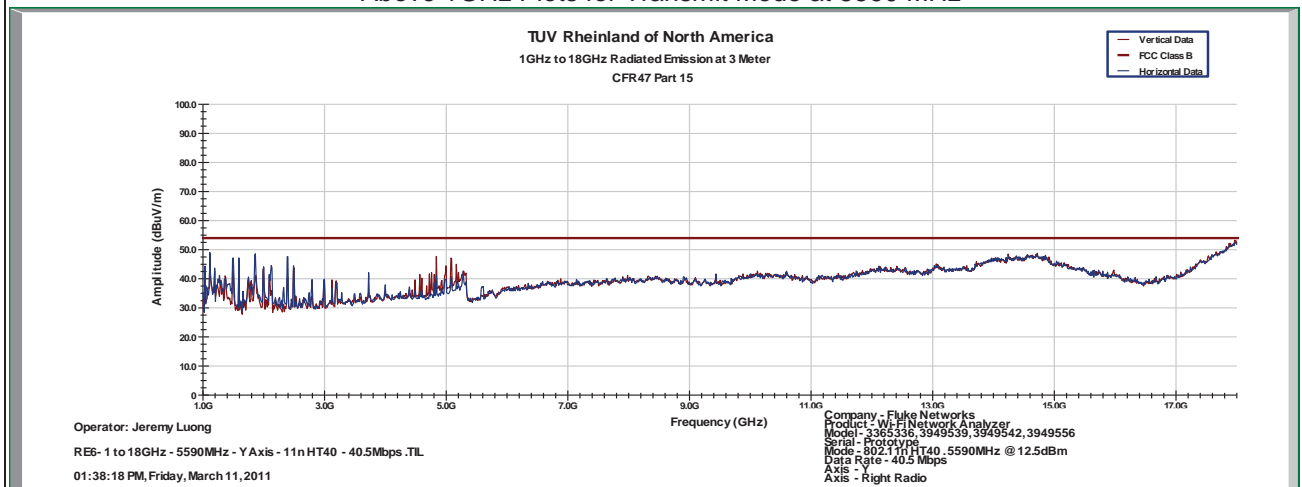

Notes: Limit was extrapolated to 1m distance for 18GHz – 40 GHz range.

SOP 1 Radiated Emissions

Tracking # 31053887.002 Page 14 of 16

EUT Name	OPTIVIEW XG, OPVXG, OPTIVIEW XG-10G, OPVXG-10G, OPVXGPRO, OPVXG-EXPT, OPTIVIEW XG-LAN, OPVXG-LAN, OPVXG-LAN-10G, OPTIVIEW XG WLAN, OPVXG-WLAN	Date	March 18, 2011
EUT Model	3365336, 3949539, 3949542, 3949556, 3949616, 4020634	Temp / Hum in	22°C / 39%rh
EUT Serial	Prototype	Temp / Hum out	N/A
EUT Config.	Y-Axis, 802.11n HT40 at 40.5Mbps	Line AC	120Vac 60Hz
Standard	CFR47 Part 15 Subpart C	RBW / VBW	1 MHz / 3MHz
Dist/Ant Used	1m - RA42-K-F-4B-C	Performed by	Jeremy Luong

Above 1GHz Plots for Transmit Mode at 5590 MHz

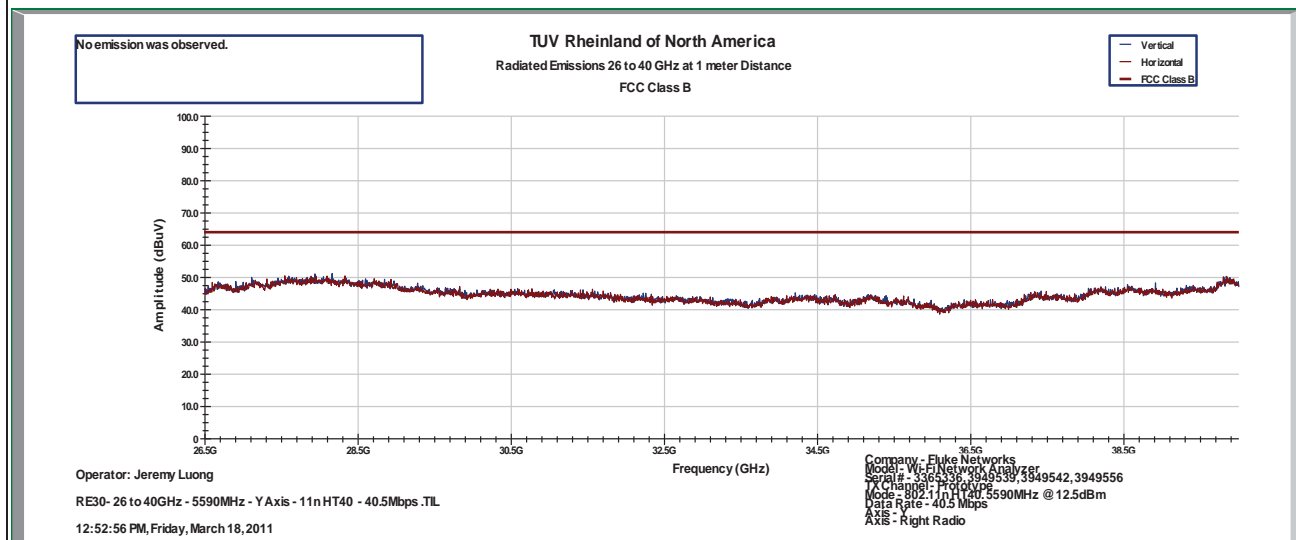

Notes: Limit was extrapolated to 1m distance for 18GHz – 40 GHz range.

SOP 1 Radiated Emissions

Tracking # 31053887.002 Page 15 of 16

EUT Name	OPTIVIEW XG, OPVXG, OPTIVIEW XG-10G, OPVXG-10G, OPVXGPRO, OPVXG-EXPT, OPTIVIEW XG-LAN, OPVXG-LAN, OPVXG-LAN-10G, OPTIVIEW XG WLAN, OPVXG-WLAN	Date	March 11, 2011
EUT Model	3365336, 3949539, 3949542, 3949556, 3949616, 4020634	Temp / Hum in	23°C / 39%rh
EUT Serial	Prototype	Temp / Hum out	N/A
EUT Config.	Y-Axis, 802.11n HT40 at 40.5Mbps	Line AC	120Vac 60Hz
Standard	CFR47 Part 15 Subpart C	RBW / VBW	1 MHz / 3MHz
Dist/Ant Used	3m - EMCO3115 / 1m - RA42-K-F-4B-C	Performed by	Jeremy Luong

Above 1GHz Plots for Transmit Mode at 5670 MHz

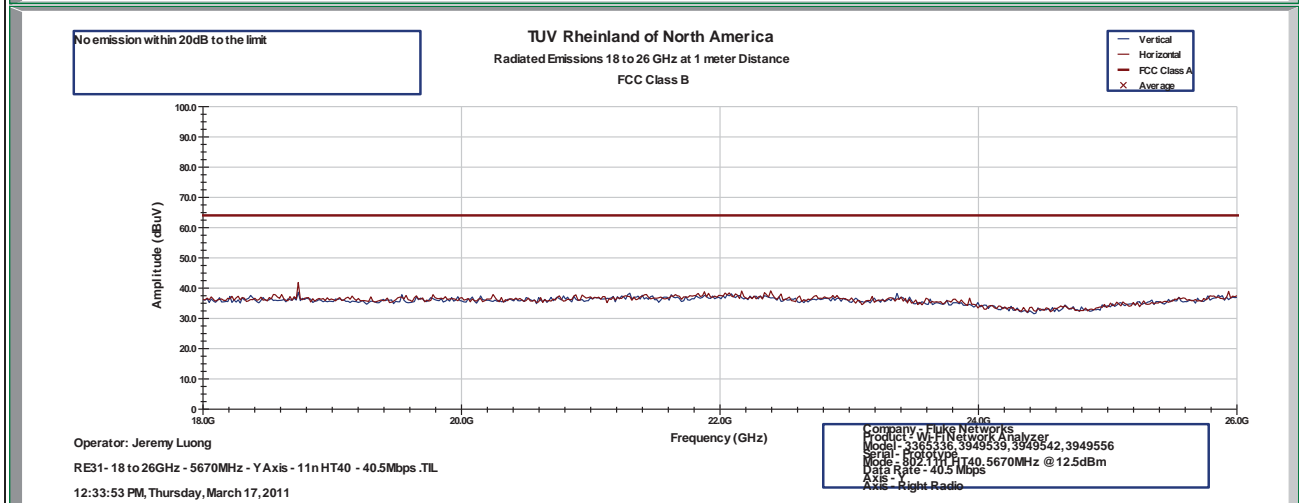
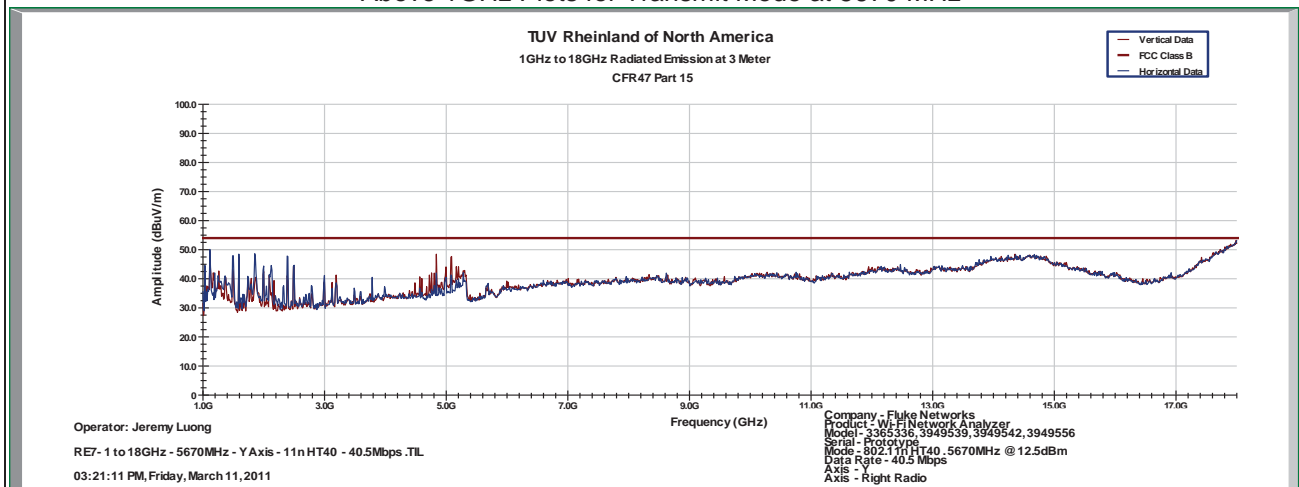

Notes: Limit was extrapolated to 1m distance for 18GHz – 40 GHz range.

SOP 1 Radiated Emissions

Tracking # 31053887.002 Page 16 of 16

EUT Name	OPTIVIEW XG, OPVXG, OPTIVIEW XG-10G, OPVXG-10G, OPVXGPRO, OPVXG-EXPT, OPTIVIEW XG-LAN, OPVXG-LAN, OPVXG-LAN-10G, OPTIVIEW XG WLAN, OPVXG-WLAN	Date	March 18, 2011
EUT Model	3365336, 3949539, 3949542, 3949556, 3949616, 4020634	Temp / Hum in	22°C / 39%rh
EUT Serial	Prototype	Temp / Hum out	N/A
EUT Config.	Y-Axis, 802.11n HT40 at 40.5Mbps	Line AC	120Vac 60Hz
Standard	CFR47 Part 15 Subpart C	RBW / VBW	1 MHz / 3MHz
Dist/Ant Used	1m - RA42-K-F-4B-C	Performed by	Jeremy Luong

Above 1GHz Plots for Transmit Mode at 5670 MHz

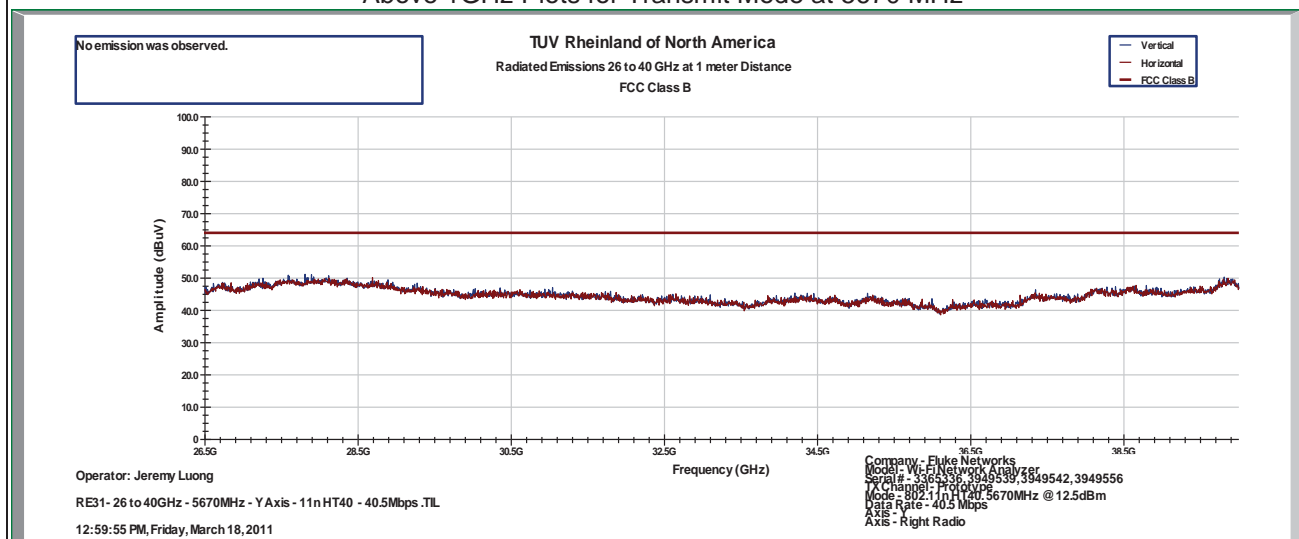

Notes: Limit was extrapolated to 1m distance for 18GHz – 40 GHz range.

4.5.4 Sample Calculation

The field strength is calculated by subtracting the Amplifier Gain and adding the Cable Loss and Antenna Correction Factor to the measured reading. The basic equation is as follows:

$$\text{Field Strength (dB}\mu\text{V/m)} = \text{FIM} - \text{AMP} + \text{CBL} + \text{ACF}$$

- Where: FIM = Field Intensity Meter (dBμV)
 AMP = Amplifier Gain (dB)
 CBL = Cable Loss (dB)
 ACF = Antenna Correction Factor (dB/m)

$$\mu\text{V/m} = 10^{\frac{\text{dB}\mu\text{V} / \text{m}}{20}}$$

4.6 Receiver Spurious Emissions

Receiver spurious emissions are emissions at any frequency when the equipment is in receive mode.

The spurious emissions of the receiver shall not exceed the values in CFR47 Part 15.109 and RSS 210 Sect 2.7.

4.6.1 Test Methodology

4.6.1.1 Preliminary Test

A test program that controls instrumentation and data logging was used to automate the preliminary RF emission test procedure. The frequency range of interest was divided into sub-ranges to yield a frequency resolution of approximately 120 kHz and provide a reading at each frequency for no more than 12° of turntable rotation. For each frequency sub-range the turntable was rotated 360° while peak emission data was recorded and plotted over the frequency range of interest in horizontal and vertical antenna polarization's.

Preliminary emission profile testing was performed inside the anechoic chamber. The EUT was placed on a 1.0m x 1.5m non-conductive table 80cm above the floor. The EUT was positioned as shown in the setup photographs. The receiving antenna was placed at a distance of 3m at a fixed height of 1m. Measurement equipment was located outside of the chamber. A video camera was placed inside the chamber to view the EUT.

Pre-scans were performed to determine the worst orientation.

4.6.1.2 Final Test

For each frequency measured, the peak emission was maximized by manipulating the receiving antenna from 1 to 4 meters above the ground plane and placing it at the position that produced the maximum signal strength reading. The turntable was then rotated through 360° while observing the peak signal and placing the EUT at the position that produced maximum radiation. The six highest emissions relative to the limit were measured unless such emissions were more than 20 dB below the limit. If less than six emissions are within 20 dB of the limit, than the noise level of the receiver is measured at frequencies where emissions are expected. Multiples of all oscillator and microprocessor frequencies were also checked.

Final testing was performed on an NSA compliant test site. The EUT was placed on a 1.0m x 1.5m non-conductive table 80cm above the ground plane. The placement of EUT and cables were the same as for preliminary testing and is shown in the setup photographs.

The final scans were performed at the middle channel for each frequency band on Y-Axis.

20 MHz Receiving Bandwidth:

Operating Frequency 5220 MHz for 5150 MHz – 5250 MHz band

Operating Frequency 5300 MHz for 5250 MHz – 5350 MHz band

Operating Frequency 5600 MHz for 5470 MHz – 5725MHz band

40 MHz Receiving Bandwidth:

Operating Frequency 5230 MHz for 5150 MHz – 5250 MHz band

Operating Frequency 5310 MHz for 5250 MHz – 5350 MHz band

Operating Frequency 5590 MHz for 5470 MHz – 5725MHz band

4.6.1.3 Deviations

None.

4.6.2 Receiver Spurious Emission Limit

The spurious emissions of the receiver shall not exceed the values in CFR47 Part 15.109: 2009 and RSS GEN Sect 6.2 2010.

Frequency (MHz)	Field strength (microvolts/meter)	Measurement distance (meters)
0.009-0.490	2400/F (kHz)	300
0.490-1.705	24000/F (kHz)	30
1.705-30.0	30	30
30-88	100 **	3
88-216	150 **	3
216-960	200 **	3
Above 960	500	3

4.6.3 Test Results

The final measurement data indicates the worst case operating modes, configurations, and/or cable positions. It also reflects the results including any modifications and/or special accessories listed in Sections 1.4 and 1.5.

As originally tested, the EUT was found to be compliant to the requirements of the test standard(s).

4.6.3.1 Final Data

The data recorded in this section contains the final results under the worst-case conditions and without any modifications or special accessories implemented as the manufacturer intends.

SOP 1 Radiated Emissions			Tracking # 31053887.002 Page 1 of 12								
EUT Name	OPTIVIEW XG, OPVXG, OPTIVIEW XG-10G, OPVXG-10G, OPVXGPRO, OPVXG-EXPT, OPTIVIEW XG-LAN, OPVXG-LAN, OPVXG-LAN-10G, OPTIVIEW XG WLAN, OPVXG-WLAN						Date	February 7, 2011			
EUT Model	3365336, 3949539, 3949542, 3949556, 3949616, 4020634						Temp / Hum in	21°C / 36%rh			
EUT Serial	Prototype						Temp / Hum out	N/A			
EUT Config.	Y-Axis, RX at 20 MHz Bandwidth						Line AC / Freq	120Vac 60Hz			
Standard	CFR47 Part 15 Subpart b						RBW / VBW	See Note			
Dist/Ant Used	3m – JB3						Performed by	Jeremy Luong			
Emission Freq (MHz)	ANT Polar (H/V)	ANT Pos (cm)	Table Pos (deg)	FIM (Pk) (dBuV/m)	FIM QP (dBuV/m)	Total CF (dBuV)	E-Field QP (dBuV/m)	Spec Limit (dBuV/m)	Spec Margin (dB)	Type	
30 MHz to 1GHz Radiated Emission - Receive Mode @ 5220 MHz											
82.93	H	228	313	62.28	60.07	-16.34	43.73	49.54	-5.81	Spurious	
83.48	H	261	332	63.83	61.36	-16.34	45.02	49.54	-4.52	Spurious	
500.03	H	158	178	49.37	47.64	-5.26	42.38	56.90	-14.52	Spurious	
625.00	H	106	182	47.09	45.87	-3.08	42.79	56.90	-14.11	Spurious	
750.07	H	158	170	44.69	39.70	-0.62	39.08	56.90	-17.82	Spurious	
871.47	H	135	203	46.97	45.59	0.80	46.39	56.90	-10.51	Spurious	
874.31	H	225	204	47.82	45.64	0.75	46.39	56.90	-10.51	Spurious	
83.18	V	105	259	63.40	60.65	-16.54	44.11	49.54	-5.43	Spurious	
84.18	V	106	317	62.67	60.17	-16.53	43.64	49.54	-5.90	Spurious	
400.01	V	126	9	48.04	47.08	-7.15	39.93	56.90	-16.97	Spurious	
500.02	V	106	355	47.43	44.83	-5.66	39.17	56.90	-17.73	Spurious	
600.00	V	108	331	37.92	35.24	-4.19	31.05	56.90	-25.85	Spurious	
871.45	V	110	196	42.72	42.19	0.25	42.44	56.90	-14.46	Spurious	
874.40	V	111	355	44.80	42.55	0.33	42.88	56.90	-14.02	Spurious	
Spec Margin = E-Field QP - Limit, E-Field QP = FIM QP+ Total CF ± Uncertainty											
Total CF= Amp Gain + Cable Loss + ANT Factor											
Combined Standard Uncertainty $u_c(y) = \pm 3.2\text{dB}$ Expanded Uncertainty $U = ku_c(y)$ $k = 2$ for 95% confidence											
Notes: Tested with a Bandwidth of 20 MHz.											
OptiView XG is a Class A device per CFR47 Part 15.109											

SOP 1 Radiated Emissions				Tracking # 31053887.002 Page 2 of 12						
EUT Name	OPTIVIEW XG, OPVXG, OPTIVIEW XG-10G, OPVXG-10G, OPVXGPRO, OPVXG-EXPT, OPTIVIEW XG-LAN, OPVXG-LAN, OPVXG-LAN-10G, OPTIVIEW XG WLAN, OPVXG-WLAN				Date	February 7, 2011				
EUT Model	3365336, 3949539, 3949542, 3949556, 3949616, 4020634				Temp / Hum in	21°C / 36%rh				
EUT Serial	Prototype				Temp / Hum out	N/A				
EUT Config.	Y-Axis, RX at 20 MHz Bandwidth				Line AC / Freq	120Vac 60Hz				
Standard	CFR47 Part 15 Subpart b				RBW / VBW	See Note				
Dist/Ant Used	3m – JB3				Performed by	Jeremy Luong				
Emission Freq (MHz)	ANT Polar (H/V)	ANT Pos (cm)	Table Pos (deg)	FIM (Pk) (dBuV/m)	FIM QP (dBuV/m)	Total CF (dBuV)	E-Field QP (dBuV/m)	Spec Limit (dBuV/m)	Spec Margin (dB)	Type
30 MHz to 1GHz Radiated Emission - Receive Mode @ 5300 MHz										
82.49	H	248	341	63.34	61.32	-16.30	45.02	49.54	-4.52	Spurious
83.38	H	266	189	63.03	61.11	-16.34	44.77	49.54	-4.77	Spurious
500.04	H	156	186	50.89	47.34	-5.26	42.08	56.90	-14.82	Spurious
625.00	H	107	195	46.29	45.25	-3.08	42.17	56.90	-14.73	Spurious
750.05	H	162	172	45.15	39.30	-0.62	38.68	56.90	-18.22	Spurious
871.50	H	145	203	46.49	45.35	0.79	46.14	56.90	-10.76	Spurious
874.54	H	133	195	47.03	45.65	0.75	46.40	56.90	-10.50	Spurious
83.54	V	121	270	61.71	60.24	-16.54	43.70	49.54	-5.84	Spurious
84.25	V	109	279	61.79	60.34	-16.53	43.81	49.54	-5.73	Spurious
400.00	V	117	348	47.91	47.31	-7.15	40.16	56.90	-16.74	Spurious
500.03	V	108	351	48.43	44.93	-5.66	39.27	56.90	-17.63	Spurious
600.04	V	108	235	35.09	32.14	-4.19	27.95	56.90	-28.95	Spurious
871.45	V	108	336	44.48	44.05	0.25	44.30	56.90	-12.60	Spurious
874.20	V	110	330	44.82	44.30	0.32	44.62	56.90	-12.28	Spurious
Spec Margin = E-Field QP - Limit, E-Field QP = FIM QP+ Total CF ± Uncertainty										
Total CF= Amp Gain + Cable Loss + ANT Factor										
Combined Standard Uncertainty $u_c(y) = \pm 3.2\text{dB}$ Expanded Uncertainty $U = ku_c(y)$ $k = 2$ for 95% confidence										
Notes: Tested with a Bandwidth of 20 MHz										
OptiView XG is a Class A device per CFR47 Part 15.109										

SOP 1 Radiated Emissions				Tracking # 31053887.002 Page 3 of 12						
EUT Name	OPTIVIEW XG, OPVXG, OPTIVIEW XG-10G, OPVXG-10G, OPVXGPRO, OPVXG-EXPT, OPTIVIEW XG-LAN, OPVXG-LAN, OPVXG-LAN-10G, OPTIVIEW XG WLAN, OPVXG-WLAN				Date	February 4, 2011				
EUT Model	3365336, 3949539, 3949542, 3949556, 3949616, 4020634				Temp / Hum in	22°C / 39%rh				
EUT Serial	Prototype				Temp / Hum out	N/A				
EUT Config.	Y-Axis, RX at 20 MHz Bandwidth				Line AC / Freq	120Vac 60Hz				
Standard	CFR47 Part 15 Subpart b				RBW / VBW	See Note				
Dist/Ant Used	3m – JB3				Performed by	Jeremy Luong				
Emission Freq (MHz)	ANT Polar (H/V)	ANT Pos (cm)	Table Pos (deg)	FIM (Pk) Pk (dBuV/m)	FIM QP (dBuV/m)	Total CF (dBuV)	E-Field QP (dBuV/m)	Spec Limit (dBuV/m)	Spec Margin (dB)	Type
30 MHz to 1GHz Radiated Emission - Receive Mode @ 5600 MHz										
82.48	H	253	185	63.18	61.64	-16.30	45.34	49.54	-4.20	Spurious
83.25	H	199	206	62.10	59.59	-16.34	43.25	49.54	-6.29	Spurious
500.03	H	155	181	51.03	47.44	-5.26	42.18	56.90	-14.72	Spurious
625.00	H	110	188	47.03	45.80	-3.08	42.72	56.90	-14.18	Spurious
750.05	H	102	172	45.08	39.49	-0.62	38.87	56.90	-18.03	Spurious
871.22	H	135	191	48.78	46.11	0.80	46.91	56.90	-9.99	Spurious
874.36	H	139	187	48.32	46.03	0.75	46.78	56.90	-10.12	Spurious
83.23	V	106	279	62.74	61.01	-16.54	44.47	49.54	-5.07	Spurious
84.32	V	110	304	62.01	60.47	-16.53	43.94	49.54	-5.60	Spurious
400.01	V	125	354	48.24	47.26	-7.15	40.11	56.90	-16.79	Spurious
500.02	V	119	20	45.38	42.53	-5.66	36.87	56.90	-20.03	Spurious
600.02	V	120	350	36.48	34.21	-4.19	30.02	56.90	-26.88	Spurious
871.20	V	106	332	46.80	44.86	0.25	45.11	56.90	-11.79	Spurious
874.22	V	114	333	43.68	43.07	0.32	43.39	56.90	-13.51	Spurious
Spec Margin = E-Field QP - Limit, E-Field QP = FIM QP+ Total CF ± Uncertainty										
Total CF= Amp Gain + Cable Loss + ANT Factor										
Combined Standard Uncertainty $u_c(y) = \pm 3.2\text{dB}$ Expanded Uncertainty $U = ku_c(y)$ $k = 2$ for 95% confidence										
Notes: Tested with a Bandwidth of 20 MHz										
OptiView XG is a Class A device per CFR47 Part 15.109										

SOP 1 Radiated Emissions				Tracking # 31053887.002 Page 4 of 12						
EUT Name	OPTIVIEW XG, OPVXG, OPTIVIEW XG-10G, OPVXG-10G, OPVXGPRO, OPVXG-EXPT, OPTIVIEW XG-LAN, OPVXG-LAN, OPVXG-LAN-10G, OPTIVIEW XG WLAN, OPVXG-WLAN				Date	February 8, 2011				
EUT Model	3365336, 3949539, 3949542, 3949556, 3949616, 4020634				Temp / Hum in	21°C / 37%rh				
EUT Serial	Prototype				Temp / Hum out	N/A				
EUT Config.	Y-Axis, RX at 40 MHz Bandwidth				Line AC / Freq	120Vac 60Hz				
Standard	CFR47 Part 15 Subpart b				RBW / VBW	See Note				
Dist/Ant Used	3m – JB3				Performed by	Jeremy Luong				
Emission Freq (MHz)	ANT Polar (H/V)	ANT Pos (cm)	Table Pos (deg)	FIM (Pk) Pk (dBuV/m)	FIM QP (dBuV/m)	Total CF (dBuV)	E-Field QP (dBuV/m)	Spec Limit (dBuV/m)	Spec Margin (dB)	Type
30 MHz to 1GHz Radiated Emission - Receive Mode @ 5230 MHz										
83.63	V	123	306	62.11	60.24	-16.54	43.70	49.54	-5.84	Spurious
84.36	V	105	254	62.05	60.13	-16.53	43.60	49.54	-5.94	Spurious
399.99	V	131	23	48.60	47.37	-7.15	40.22	56.90	-16.68	Spurious
500.01	V	110	26	46.27	43.89	-5.66	38.23	56.90	-18.67	Spurious
599.98	V	110	355	36.48	33.15	-4.19	28.96	56.90	-27.94	Spurious
871.45	V	109	335	44.37	43.54	0.25	43.79	56.90	-13.11	Spurious
874.46	V	129	41	44.44	42.62	0.33	42.95	56.90	-13.95	Spurious
82.78	H	263	179	64.16	61.36	-16.33	45.03	49.54	-4.51	Spurious
83.50	H	282	344	63.27	61.20	-16.34	44.86	49.54	-4.68	Spurious
500.02	H	148	187	50.21	47.41	-5.26	42.15	56.90	-14.75	Spurious
625.00	H	106	181	47.09	45.78	-3.08	42.70	56.90	-14.20	Spurious
750.05	H	159	172	44.88	39.52	-0.62	38.90	56.90	-18.00	Spurious
871.53	H	135	200	47.32	45.62	0.79	46.41	56.90	-10.49	Spurious
874.40	H	137	195	48.31	45.68	0.75	46.43	56.90	-10.47	Spurious
Spec Margin = E-Field QP - Limit, E-Field QP = FIM QP+ Total CF ± Uncertainty										
Total CF= Amp Gain + Cable Loss + ANT Factor										
Combined Standard Uncertainty $u_c(y) = \pm 3.2\text{dB}$ Expanded Uncertainty $U = ku_c(y)$ $k = 2$ for 95% confidence										
Notes: Tested with a Bandwidth of 40 MHz										
OptiView XG is a Class A device per CFR47 Part 15.109										

SOP 1 Radiated Emissions				Tracking # 31053887.002 Page 5 of 12						
EUT Name	OPTIVIEW XG, OPVXG, OPTIVIEW XG-10G, OPVXG-10G, OPVXGPRO, OPVXG-EXPT, OPTIVIEW XG-LAN, OPVXG-LAN, OPVXG-LAN-10G, OPTIVIEW XG WLAN, OPVXG-WLAN				Date	February 7, 2011				
EUT Model	3365336, 3949539, 3949542, 3949556, 3949616, 4020634				Temp / Hum in	21°C / 37%rh				
EUT Serial	Prototype				Temp / Hum out	N/A				
EUT Config.	Y-Axis, RX at 40 MHz Bandwidth				Line AC / Freq	120Vac 60Hz				
Standard	CFR47 Part 15 Subpart b				RBW / VBW	See Note				
Dist/Ant Used	3m – JB3				Performed by	Jeremy Luong				
Emission Freq (MHz)	ANT Polar (H/V)	ANT Pos (cm)	Table Pos (deg)	FIM (Pk) Pk (dBuV/m)	FIM QP (dBuV/m)	Total CF (dBuV)	E-Field QP (dBuV/m)	Spec Limit (dBuV/m)	Spec Margin (dB)	Type
30 MHz to 1GHz Radiated Emission - Receive Mode @ 5310 MHz										
82.85	H	261	196	63.33	61.16	-16.33	44.83	49.54	-4.71	Spurious
83.63	H	241	333	63.00	61.55	-16.34	45.21	49.54	-4.33	Spurious
500.03	H	179	168	49.98	46.47	-5.26	41.21	56.90	-15.69	Spurious
625.00	H	117	197	46.08	45.21	-3.08	42.13	56.90	-14.77	Spurious
750.05	H	103	170	45.28	39.28	-0.62	38.66	56.90	-18.24	Spurious
871.51	H	148	192	46.63	45.58	0.79	46.37	56.90	-10.53	Spurious
874.26	H	143	198	47.31	45.67	0.75	46.42	56.90	-10.48	Spurious
83.43	V	128	317	62.26	59.92	-16.54	43.38	49.54	-6.16	Spurious
84.16	V	120	308	61.77	60.06	-16.53	43.53	49.54	-6.01	Spurious
400.00	V	127	350	48.52	47.29	-7.15	40.14	56.90	-16.76	Spurious
500.03	V	109	351	48.00	44.83	-5.66	39.17	56.90	-17.73	Spurious
600.01	V	109	345	39.08	35.78	-4.19	31.59	56.90	-25.31	Spurious
871.36	V	113	331	44.86	43.85	0.25	44.10	56.90	-12.80	Spurious
874.42	V	105	330	46.62	45.09	0.33	45.42	56.90	-11.48	Spurious
Spec Margin = E-Field QP - Limit, E-Field QP = FIM QP+ Total CF ± Uncertainty										
Total CF= Amp Gain + Cable Loss + ANT Factor										
Combined Standard Uncertainty $u_c(y) = \pm 3.2\text{dB}$ Expanded Uncertainty $U = ku_c(y)$ $k = 2$ for 95% confidence										
Notes: Tested with a Bandwidth of 40 MHz										
OptiView XG is a Class A device per CFR47 Part 15.109										

SOP 1 Radiated Emissions				Tracking # 31053887.002 Page 6 of 12						
EUT Name	OPTIVIEW XG, OPVXG, OPTIVIEW XG-10G, OPVXG-10G, OPVXGPRO, OPVXG-EXPT, OPTIVIEW XG-LAN, OPVXG-LAN, OPVXG-LAN-10G, OPTIVIEW XG WLAN, OPVXG-WLAN				Date	February 4, 2011				
EUT Model	3365336, 3949539, 3949542, 3949556, 3949616, 4020634				Temp / Hum in	22°C / 39%rh				
EUT Serial	Prototype				Temp / Hum out	N/A				
EUT Config.	Y-Axis, RX at 40 MHz Bandwidth				Line AC / Freq	120Vac 60Hz				
Standard	CFR47 Part 15 Subpart b				RBW / VBW	See Note				
Dist/Ant Used	3m – JB3				Performed by	Jeremy Luong				
Emission Freq (MHz)	ANT Polar (H/V)	ANT Pos (cm)	Table Pos (deg)	FIM (Pk) (dBuV/m)	FIM QP (dBuV/m)	Total CF (dBuV)	E-Field QP (dBuV/m)	Spec Limit (dBuV/m)	Spec Margin (dB)	Type
30 MHz to 1GHz Radiated Emission - Receive Mode @ 5590 MHz										
83.21	V	106	307	62.96	60.82	-16.54	44.28	49.54	-5.26	Spurious
84.41	V	106	315	61.48	60.39	-16.53	43.86	49.54	-5.68	Spurious
400.00	V	119	353	48.41	47.31	-7.15	40.16	56.90	-16.74	Spurious
500.02	V	106	5	48.2	44.74	-5.66	39.08	56.90	-17.82	Spurious
599.97	V	110	351	38.64	35.92	-4.19	31.73	56.90	-25.17	Spurious
871.29	V	134	45	45.86	43.24	0.25	43.49	56.90	-13.41	Spurious
874.24	V	109	340	44.96	43.75	0.32	44.07	56.90	-12.83	Spurious
82.90	H	252	340	63.66	61.57	-16.34	45.23	49.54	-4.31	Spurious
83.51	H	217	200	62.33	60.52	-16.34	44.18	49.54	-5.36	Spurious
500.05	H	158	189	50.59	46.77	-5.26	41.51	56.90	-15.39	Spurious
625.02	H	115	196	46.69	45.33	-3.08	42.25	56.90	-14.65	Spurious
750.06	H	159	171	45.12	39.26	-0.62	38.64	56.90	-18.26	Spurious
871.49	H	133	193	46.95	45.66	0.79	46.45	56.90	-10.45	Spurious
874.38	H	132	190	48.06	45.68	0.75	46.43	56.90	-10.47	Spurious
Spec Margin = E-Field QP - Limit, E-Field QP = FIM QP+ Total CF ± Uncertainty Total CF= Amp Gain + Cable Loss + ANT Factor Combined Standard Uncertainty $u_c(y) = \pm 3.2\text{dB}$ Expanded Uncertainty $U = ku_c(y)$ $k = 2$ for 95% confidence										
Notes: Tested with a Bandwidth of 40 MHz OptiView XG is a Class A device per CFR47 Part 15.109										

SOP 1 Radiated Emissions

Tracking # 31053887.002 Page 7 of 12

EUT Name	OPTIVIEW XG, OPVXG, OPTIVIEW XG-10G, OPVXG-10G, OPVXGPRO, OPVXG-EXPT, OPTIVIEW XG-LAN, OPVXG-LAN, OPVXG-LAN-10G, OPTIVIEW XG WLAN, OPVXG-WLAN	Date	February 7, 2011
EUT Model	3365336, 3949539, 3949542, 3949556, 3949616, 4020634	Temp / Hum in	21°C / 36%rh
EUT Serial	Prototype	Temp / Hum out	N/A
EUT Config.	Y-Axis, RX at 5220 MHz, 20 MHz Bandwidth	Line AC	120Vac 60Hz
Standard	CFR47 Part 15 Subpart b	RBW / VBW	120 kHz / 300 kHz
Dist/Ant Used	3m – JB3	Performed by	Jeremy Luong

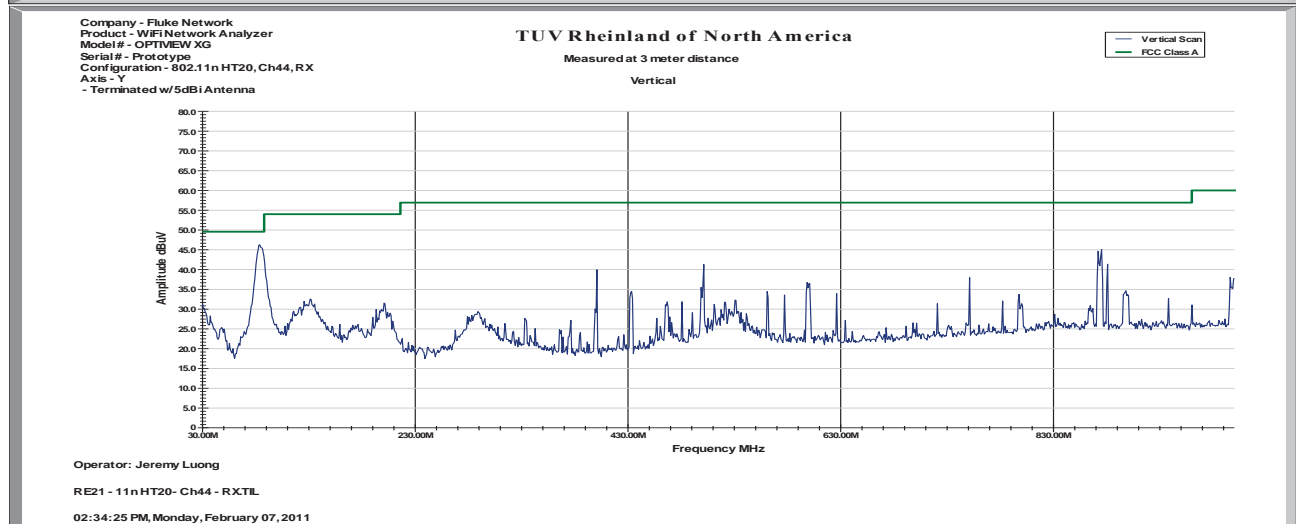
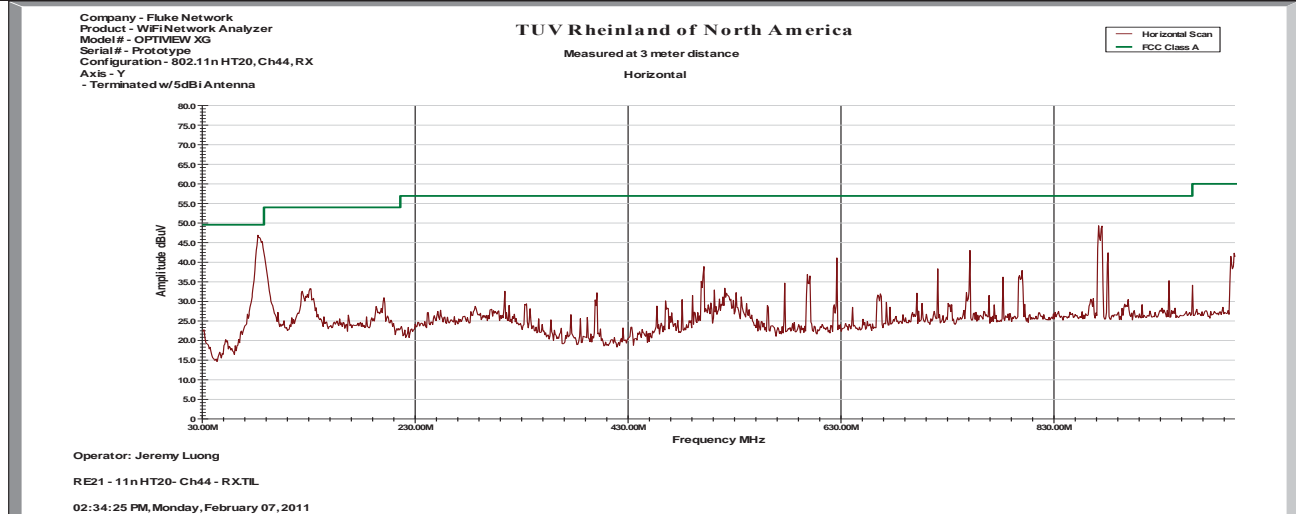

Notes: Tested with a Bandwidth of 20 MHz

SOP 1 Radiated Emissions

Tracking # 31053887.002 Page 8 of 12

EUT Name	OPTIVIEW XG, OPVXG, OPTIVIEW XG-10G, OPVXG-10G, OPVXGPRO, OPVXG-EXPT, OPTIVIEW XG-LAN, OPVXG-LAN, OPVXG-LAN-10G, OPTIVIEW XG WLAN, OPVXG-WLAN	Date	February 7, 2011
EUT Model	3365336, 3949539, 3949542, 3949556, 3949616, 4020634	Temp / Hum in	21°C / 36%rh
EUT Serial	Prototype	Temp / Hum out	N/A
EUT Config.	Y-Axis, RX at 5300 MHz, 20 MHz Bandwidth	Line AC	120Vac 60Hz
Standard	CFR47 Part 15 Subpart b	RBW / VBW	120 kHz / 300 kHz
Dist/Ant Used	3m – JB3	Performed by	Jeremy Luong

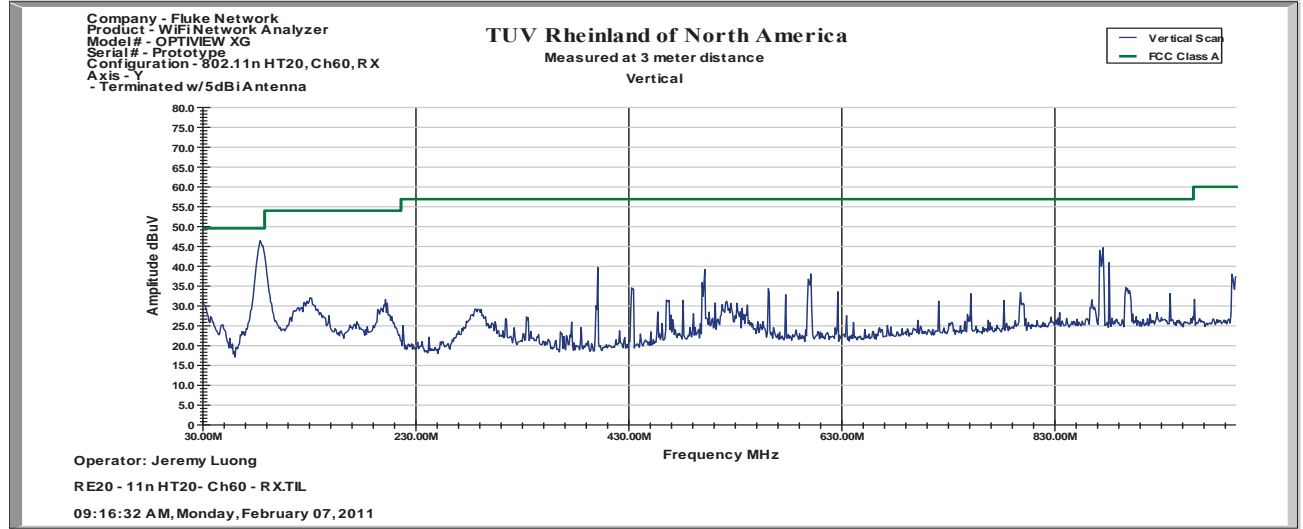
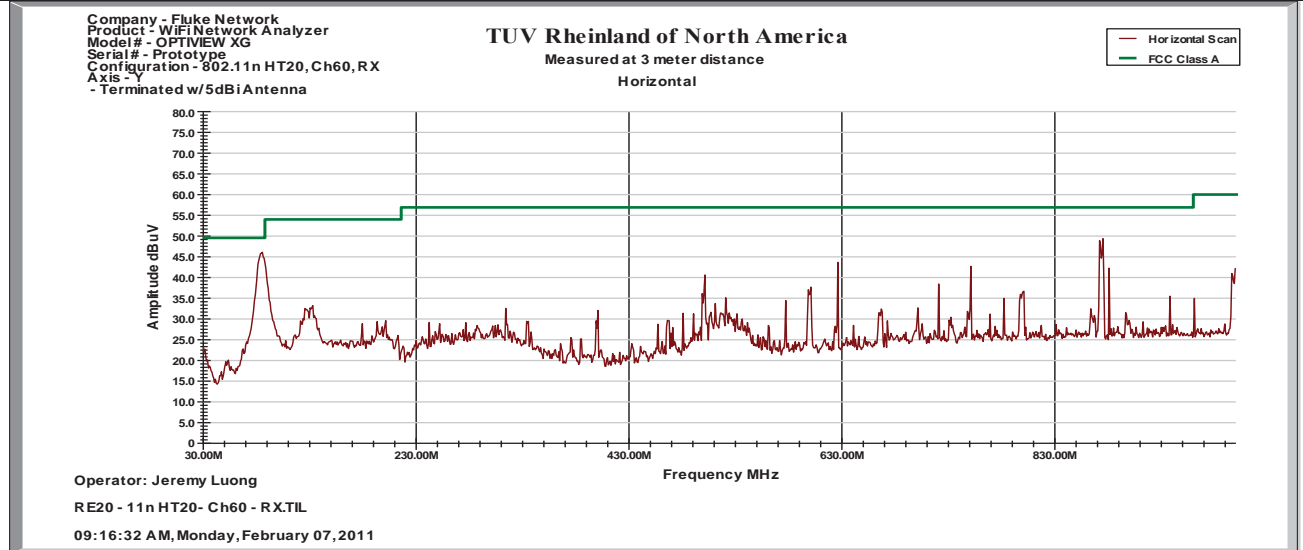

Notes: Tested with a Bandwidth of 20 MHz

SOP 1 Radiated Emissions

Tracking # 31053887.002 Page 9 of 12

EUT Name	OPTIVIEW XG, OPVXG, OPTIVIEW XG-10G, OPVXG-10G, OPVXGPRO, OPVXG-EXPT, OPTIVIEW XG-LAN, OPVXG-LAN, OPVXG-LAN-10G, OPTIVIEW XG WLAN, OPVXG-WLAN	Date	February 4, 2011
EUT Model	3365336, 3949539, 3949542, 3949556, 3949616, 4020634	Temp / Hum in	22°C / 39%rh
EUT Serial	Prototype	Temp / Hum out	N/A
EUT Config.	Y-Axis, RX at 5600 MHz, 20 MHz Bandwidth	Line AC	120Vac 60Hz
Standard	CFR47 Part 15 Subpart b	RBW / VBW	120 kHz / 300 kHz
Dist/Ant Used	3m – JB3	Performed by	Jeremy Luong

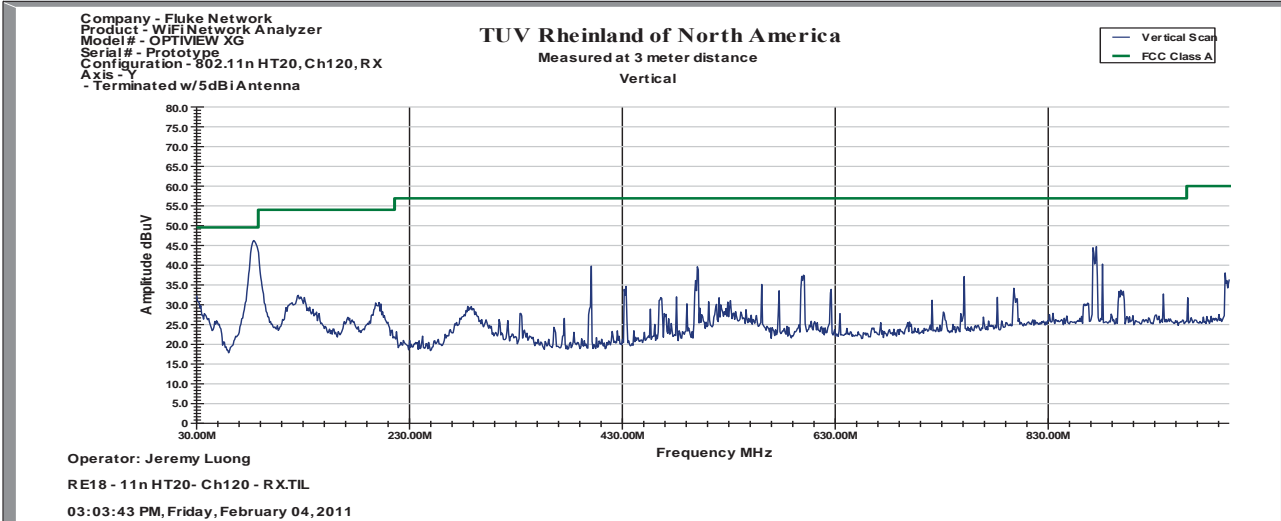
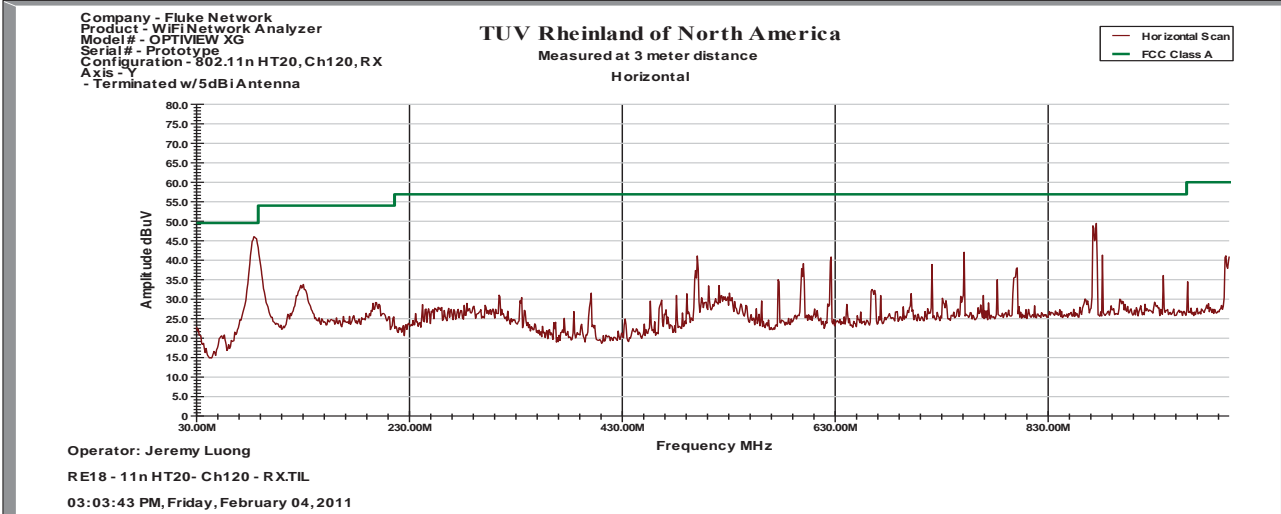

Notes: Tested with a Bandwidth of 20 MHz

SOP 1 Radiated Emissions

Tracking # 31053887.002 Page 10 of 12

EUT Name	OPTIVIEW XG, OPVXG, OPTIVIEW XG-10G, OPVXG-10G, OPVXGPRO, OPVXG-EXPT, OPTIVIEW XG-LAN, OPVXG-LAN, OPVXG-LAN-10G, OPTIVIEW XG WLAN, OPVXG-WLAN	Date	February 8, 2011
EUT Model	3365336, 3949539, 3949542, 3949556, 3949616, 4020634	Temp / Hum in	21°C / 37%rh
EUT Serial	Prototype	Temp / Hum out	N/A
EUT Config.	Y-Axis, RX at 5230 MHz, 40 MHz Bandwidth	Line AC	120Vac 60Hz
Standard	CFR47 Part 15 Subpart b	RBW / VBW	120 kHz / 300 kHz
Dist/Ant Used	3m – JB3	Performed by	Jeremy Luong

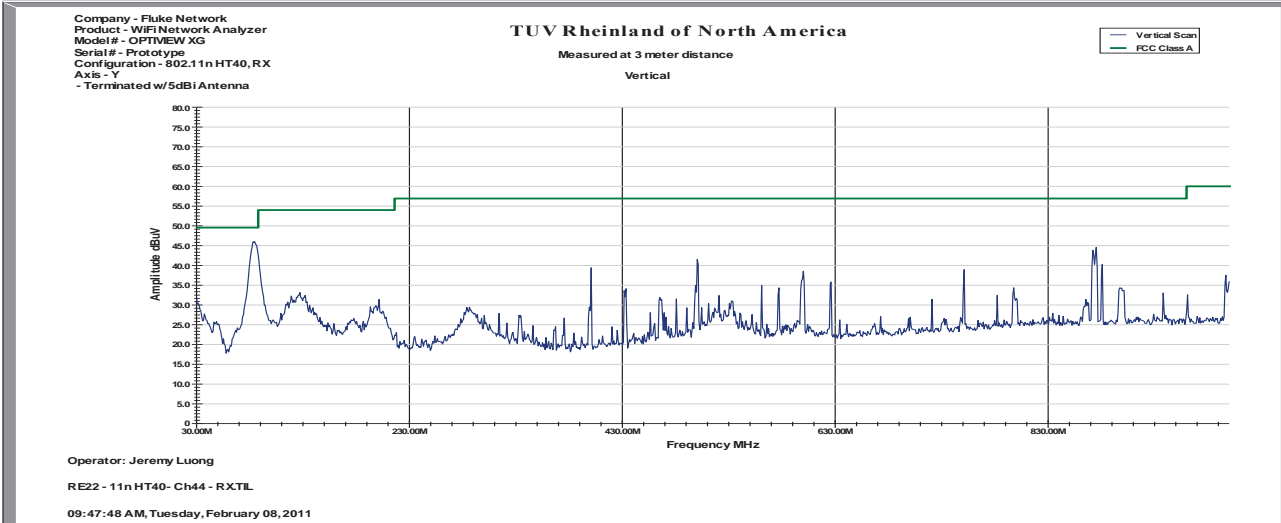
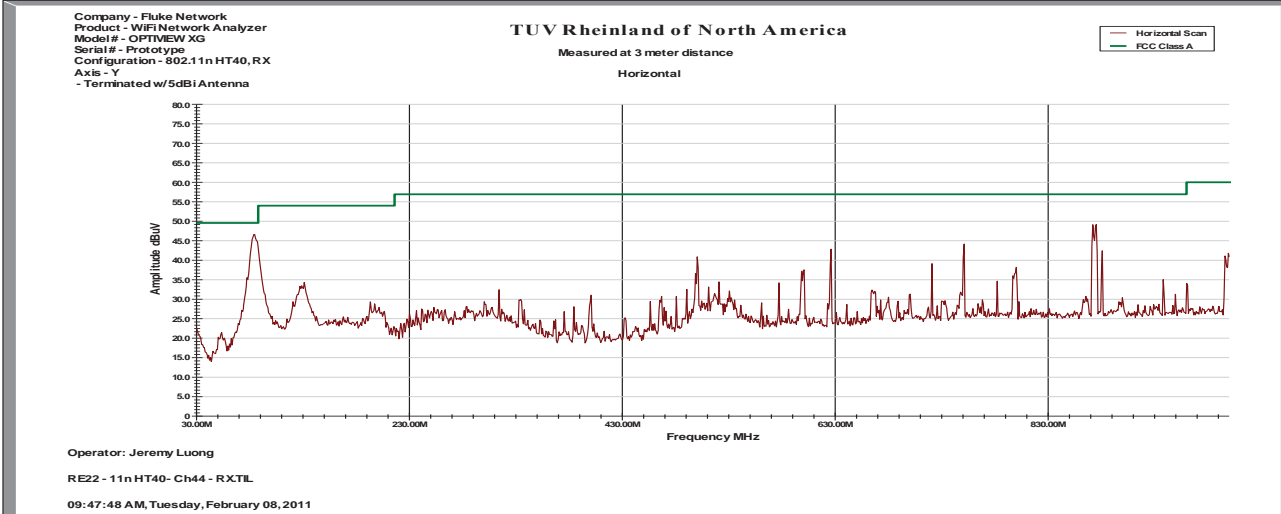

Notes: Tested with a Bandwidth of 40 MHz

SOP 1 Radiated Emissions

Tracking # 31053887.002 Page 11 of 12

EUT Name	OPTIVIEW XG, OPVXG, OPTIVIEW XG-10G, OPVXG-10G, OPVXGPRO, OPVXG-EXPT, OPTIVIEW XG-LAN, OPVXG-LAN, OPVXG-LAN-10G, OPTIVIEW XG WLAN, OPVXG-WLAN	Date	February 7, 2011
EUT Model	3365336, 3949539, 3949542, 3949556, 3949616, 4020634	Temp / Hum in	21°C / 37%rh
EUT Serial	Prototype	Temp / Hum out	N/A
EUT Config.	Y-Axis, RX at 5310 MHz, 40 MHz Bandwidth	Line AC	120Vac 60Hz
Standard	CFR47 Part 15 Subpart b	RBW / VBW	120 kHz / 300 kHz
Dist/Ant Used	3m – JB3	Performed by	Jeremy Luong

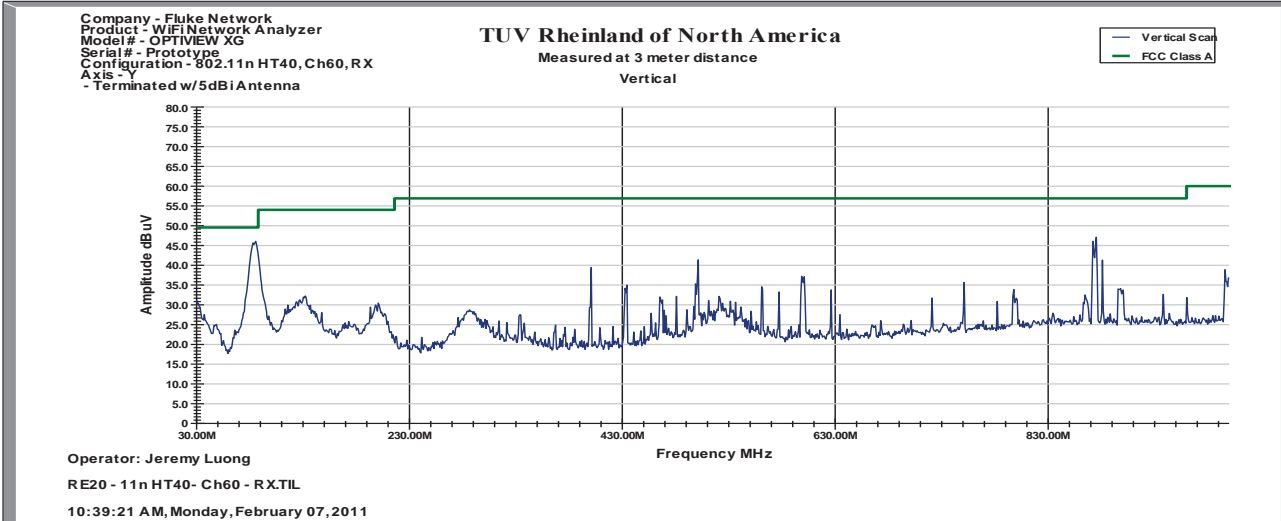
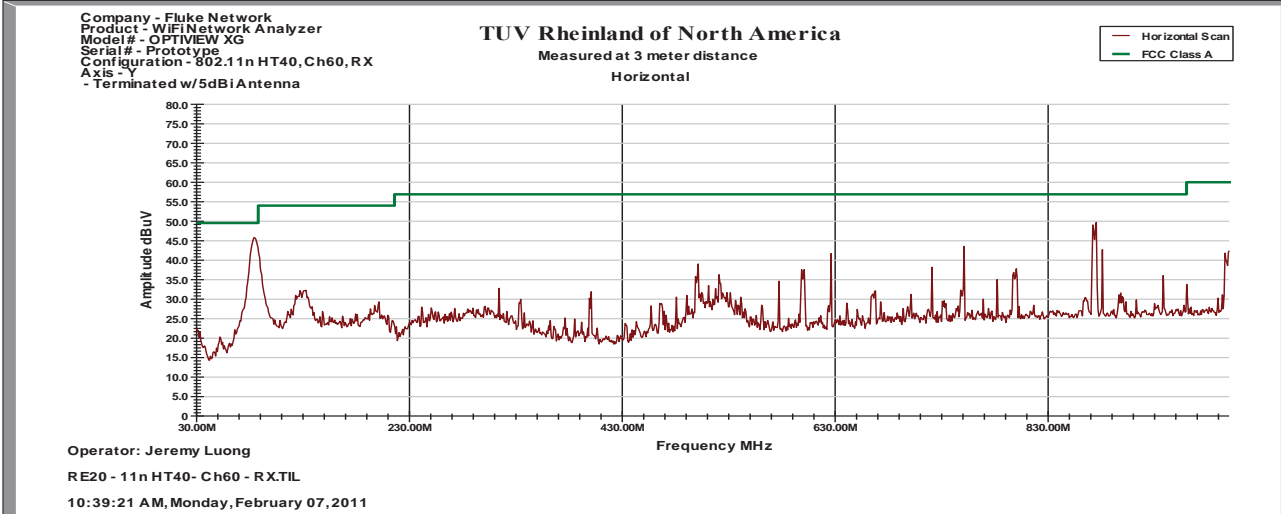

Notes: Tested with a Bandwidth of 40 MHz

SOP 1 Radiated Emissions

Tracking # 31053887.002 Page 12 of 12

EUT Name	OPTIVIEW XG, OPVXG, OPTIVIEW XG-10G, OPVXG-10G, OPVXGPRO, OPVXG-EXPT, OPTIVIEW XG-LAN, OPVXG-LAN, OPVXG-LAN-10G, OPTIVIEW XG WLAN, OPVXG-WLAN	Date	February 4, 2011
EUT Model	3365336, 3949539, 3949542, 3949556, 3949616, 4020634	Temp / Hum in	22°C / 39%rh
EUT Serial	Prototype	Temp / Hum out	N/A
EUT Config.	Y-Axis, RX at 5590 MHz, 40 MHz Bandwidth	Line AC	120Vac 60Hz
Standard	CFR47 Part 15 Subpart b	RBW / VBW	120 kHz / 300 kHz
Dist/Ant Used	3m – JB3	Performed by	Jeremy Luong

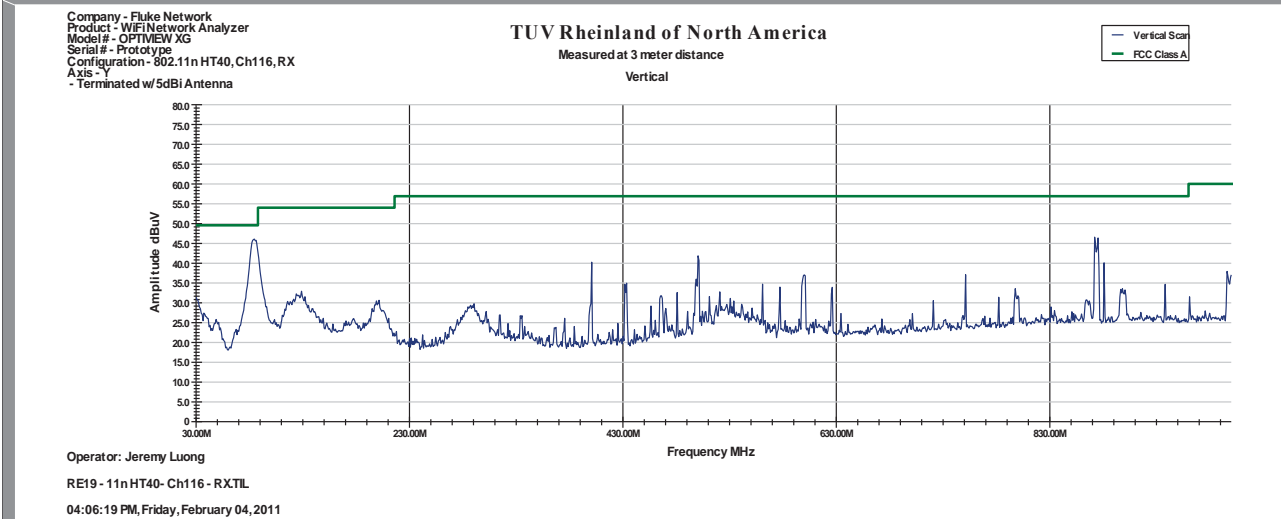
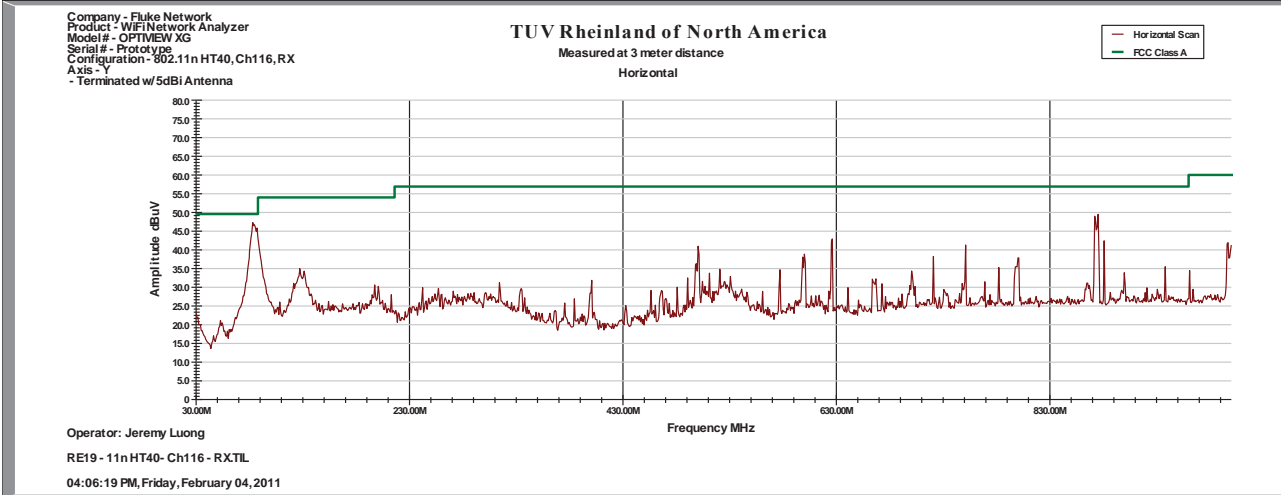

Notes: Tested with a Bandwidth of 40 MHz

SOP 1 Radiated Emissions											Tracking # 31053887.002 Page 1 of 14	
EUT Name	OPTIVIEW XG, OPVXG, OPTIVIEW XG-10G, OPVXG-10G, OPVXGPRO, OPVXG-EXPT, OPTIVIEW XG-LAN, OPVXG-LAN, OPVXG-LAN-10G, OPTIVIEW XG WLAN, OPVXG-WLAN						Date	March 18, 2011				
EUT Model	3365336, 3949539, 3949542, 3949556, 3949616, 4020634						Temp / Hum in	21°C / 39%rh				
EUT Serial	Prototype						Temp / Hum out	N/A				
EUT Config.	Y-Axis, RX at 20 MHz Bandwidth						Line AC / Freq	120Vac 60Hz				
Standard	CFR47 Part 15 Subpart b						RBW / VBW	See Note				
Dist/Ant Used	3m – JB3, EMCO3115 / 1m - RA42-K-F-4B-C						Performed by	Jeremy Luong				
Emission Freq (MHz)	ANT Polar (H/V)	ANT Pos (cm)	Table Pos (deg)	FIM (Pk) (dBuV/m)	FIM QP (dBuV/m)	Total CF (dBuV)	E-Field QP (dBuV/m)	Spec Limit (dBuV/m)	Spec Margin (dB)	Type		
Above 1GHz - Receive Mode @ 5220 MHz												
1120.19	H	114	29	61.98	48.87	-8.62	40.25	53.98	-13.73	Spurious		
1597.28	H	199	244	61.99	40.41	-6.82	33.59	53.98	-20.39	Spurious		
1861.09	H	139	194	59.63	46.94	-4.94	42.00	53.98	-11.98	Spurious		
2391.85	H	207	185	56.74	35.99	-3.01	32.98	53.98	-21.00	Spurious		
Above 1GHz - Receive Mode @ 5300 MHz												
1120.22	H	119	30	62.95	49.50	-8.62	40.88	53.98	-13.10	Spurious		
1595.42	H	134	250	61.33	41.27	-6.83	34.44	53.98	-19.54	Spurious		
1861.15	H	139	210	59.85	47.25	-4.94	42.31	53.98	-11.67	Spurious		
2392.78	H	204	132	54.35	35.00	-3.01	31.99	53.98	-21.99	Spurious		
Above 1GHz - Receive Mode @ 5600 MHz												
1200.12	H	118	387	58.05	48.01	-8.00	40.01	53.98	-13.97	Spurious		
1595.16	H	120	187	58.32	40.40	-6.83	33.57	53.98	-20.41	Spurious		
1861.15	H	141	223	60.27	47.14	-4.94	42.20	53.98	-11.78	Spurious		
2392.96	H	206	130	55.37	35.14	-3.00	32.14	53.98	-21.84	Spurious		
4979.03	V	200	334	40.38	24.50	2.79	27.30	53.98	-26.68	Spurious		
Spec Margin = E-Field QP - Limit, E-Field QP = FIM QP+ Total CF ± Uncertainty												
Total CF= Amp Gain + Cable Loss + ANT Factor												
Combined Standard Uncertainty $u_c(y) = \pm 3.2\text{dB}$ Expanded Uncertainty $U = ku_c(y)$ $k = 2$ for 95% confidence												
Notes: Tested with a Bandwidth of 20 MHz												

SOP 1 Radiated Emissions			Tracking # 31053887.002 Page 2 of 14							
EUT Name	OPTIVIEW XG, OPVXG, OPTIVIEW XG-10G, OPVXG-10G, OPVXGPRO, OPVXG-EXPT, OPTIVIEW XG-LAN, OPVXG-LAN, OPVXG-LAN-10G, OPTIVIEW XG WLAN, OPVXG-WLAN						Date	March 18, 2011		
EUT Model	3365336, 3949539, 3949542, 3949556, 3949616, 4020634						Temp / Hum in	21°C / 39%rh		
EUT Serial	Prototype						Temp / Hum out	N/A		
EUT Config.	Y-Axis, RX at 40 MHz bandwidth						Line AC / Freq	120Vac 60Hz		
Standard	CFR47 Part 15 Subpart b						RBW / VBW	See Note		
Dist/Ant Used	3m – JB3, EMCO3115 / 1m - RA42-K-F-4B-C						Performed by	Jeremy Luong		
Emission Freq (MHz)	ANT Polar (H/V)	ANT Pos (cm)	Table Pos (deg)	FIM (Pk) (dBuV/m)	FIM QP (dBuV/m)	Total CF (dBuV)	E-Field QP (dBuV/m)	Spec Limit (dBuV/m)	Spec Margin (dB)	Type
Above 1GHz - Receive Mode @ 5230 MHz										
1200.1	H	120	22	56.24	49.19	-8	41.19	53.98	-12.79	Spurious
1595.49	H	137	253	61.95	40.82	-6.83	33.99	53.98	-19.99	Spurious
1861.03	H	142	206	59.65	47.32	-4.94	42.38	53.98	-11.6	Spurious
2497.32	H	186	161	51.37	31.98	-2.68	29.3	53.98	-24.68	Spurious
4995.26	V	133	207	43.69	25.8	2.83	28.63	53.98	-25.35	Spurious
Above 1GHz - Receive Mode @ 5310 MHz										
1200.06	H	186	373	54.53	48.36	-8	40.36	53.98	-13.62	Spurious
1596.57	H	197	246	61.92	40.19	-6.82	33.37	53.98	-20.61	Spurious
1861.06	H	143	207	60.35	47.23	-4.94	42.29	53.98	-11.69	Spurious
2392.41	H	158	126	57.72	35.91	-3.01	32.9	53.98	-21.08	Spurious
2490.44	H	203	240	52.87	32.52	-2.68	29.84	53.98	-24.14	Spurious
Above 1GHz - Receive Mode @ 5590 MHz										
1200.06	H	116	378	55.15	49.85	-8	41.85	53.98	-12.13	Spurious
1495.42	H	123	141	60.54	41.44	-7.69	33.75	53.98	-20.23	Spurious
1595.16	H	117	192	59.66	40.39	-6.83	33.56	53.98	-20.42	Spurious
1861.21	H	139	195	60.56	46.45	-4.94	41.51	53.98	-12.47	Spurious
2392.88	H	155	126	53.87	35.49	-3	32.49	53.98	-21.49	Spurious
Spec Margin = E-Field QP - Limit, E-Field QP = FIM QP+ Total CF ± Uncertainty										
Total CF= Amp Gain + Cable Loss + ANT Factor										
Combined Standard Uncertainty $u_c(y) = \pm 3.2\text{dB}$ Expanded Uncertainty $U = ku_c(y)$ $k = 2$ for 95% confidence										
Notes: Tested with a Bandwidth of 40 MHz										

SOP 1 Radiated Emissions

Tracking # 31053887.002 Page 3 of 14

EUT Name	OPTIVIEW XG, OPVXG, OPTIVIEW XG-10G, OPVXG-10G, OPVXGPRO, OPVXG-EXPT, OPTIVIEW XG-LAN, OPVXG-LAN, OPVXG-LAN-10G, OPTIVIEW XG WLAN, OPVXG-WLAN	Date	March 18, 2011
EUT Model	3365336, 3949539, 3949542, 3949556, 3949616, 4020634	Temp / Hum in	21°C / 39%rh
EUT Serial	Prototype	Temp / Hum out	N/A
EUT Config.	Y-Axis, RX at 5220 MHz	Line AC	120Vac 60Hz
Standard	CFR47 Part 15 Subpart b	RBW / VBW	120 kHz / 300 kHz
Dist/Ant Used	3m - EMCO3115 / 1m - RA42-K-F-4B-C	Performed by	Jeremy Luong

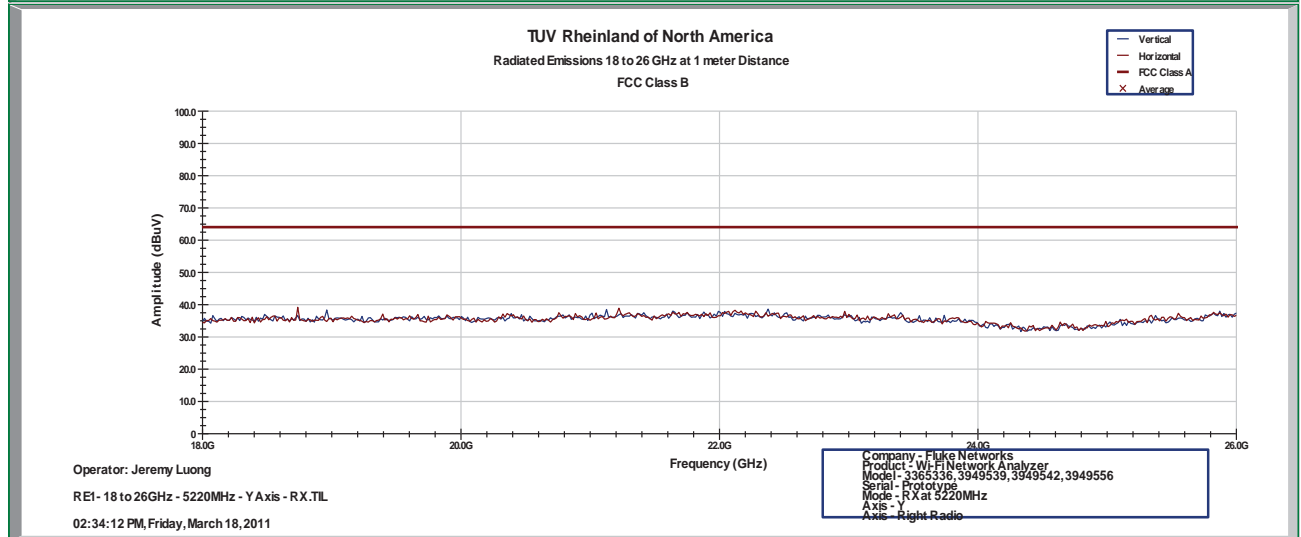
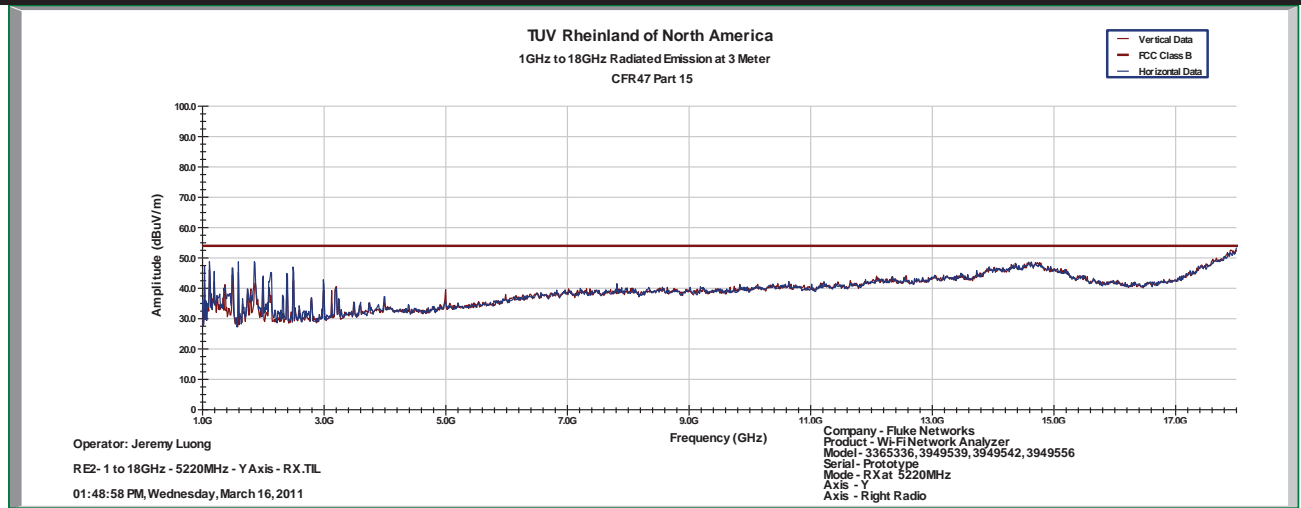

Notes: Tested with a Bandwidth of 20 MHz

SOP 1 Radiated Emissions

Tracking # 31053887.002 Page 4 of 14

EUT Name	OPTIVIEW XG, OPVXG, OPTIVIEW XG-10G, OPVXG-10G, OPVXGPRO, OPVXG-EXPT, OPTIVIEW XG-LAN, OPVXG-LAN, OPVXG-LAN-10G, OPTIVIEW XG WLAN, OPVXG-WLAN	Date	March 18, 2011
EUT Model	3365336, 3949539, 3949542, 3949556, 3949616, 4020634	Temp / Hum in	21°C / 39%rh
EUT Serial	Prototype	Temp / Hum out	N/A
EUT Config.	Y-Axis, RX at 5220 MHz	Line AC	120Vac 60Hz
Standard	CFR47 Part 15 Subpart b	RBW / VBW	1 MHz / 3MHz
Dist/Ant Used	1m - RA28-K-F-4B-C	Performed by	Jeremy Luong

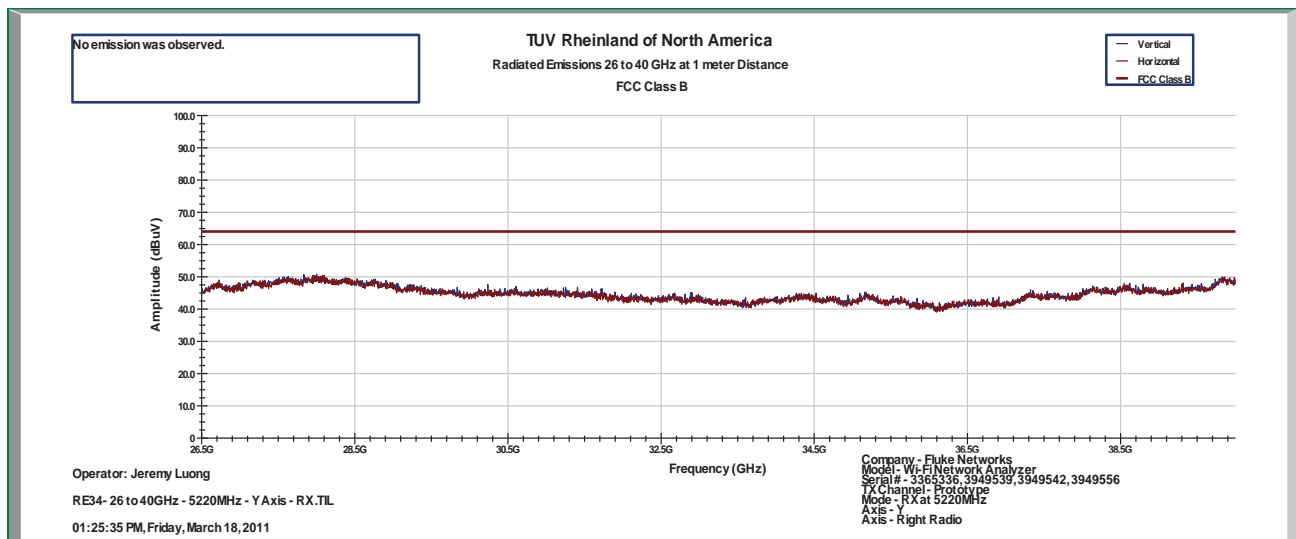

Notes: Tested with a Bandwidth of 20 MHz

SOP 1 Radiated Emissions

Tracking # 31053887.002 Page 5 of 14

EUT Name	OPTIVIEW XG, OPVXG, OPTIVIEW XG-10G, OPVXG-10G, OPVXGPRO, OPVXG-EXPT, OPTIVIEW XG-LAN, OPVXG-LAN, OPVXG-LAN-10G, OPTIVIEW XG WLAN, OPVXG-WLAN	Date	March 18, 2011
EUT Model	3365336, 3949539, 3949542, 3949556, 3949616, 4020634	Temp / Hum in	23°C / 39%rh
EUT Serial	Prototype	Temp / Hum out	N/A
EUT Config.	Y-Axis, RX at 5300 MHz	Line AC	120Vac 60Hz
Standard	CFR47 Part 15 Subpart b	RBW / VBW	120 kHz / 300 kHz
Dist/Ant Used	3m - EMCO3115 / 1m - RA42-K-F-4B-C	Performed by	Jeremy Luong

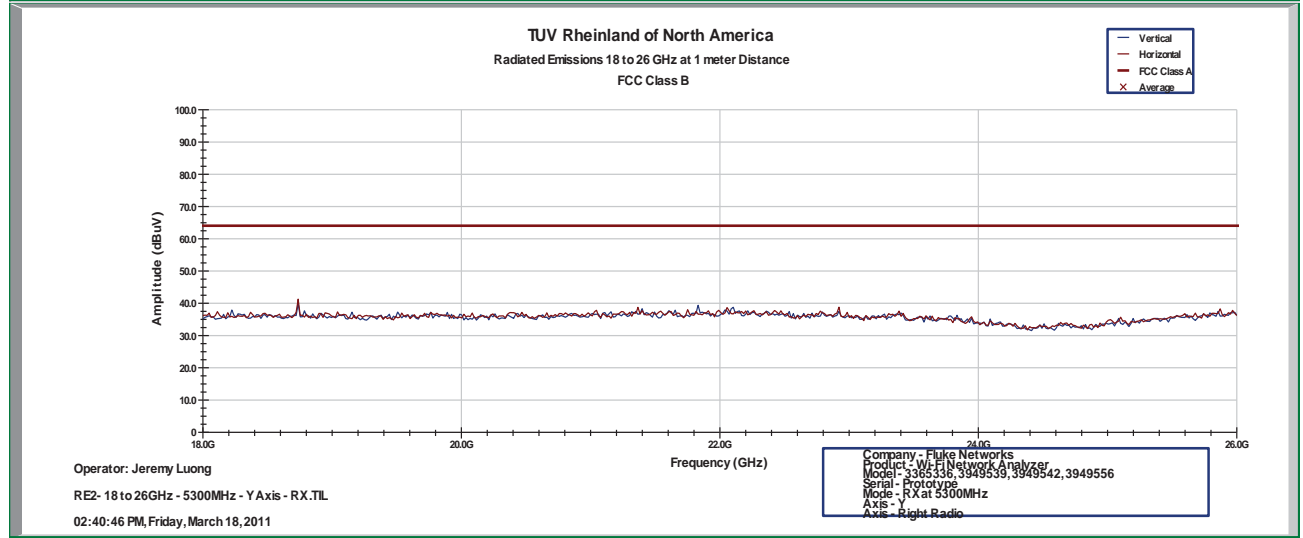
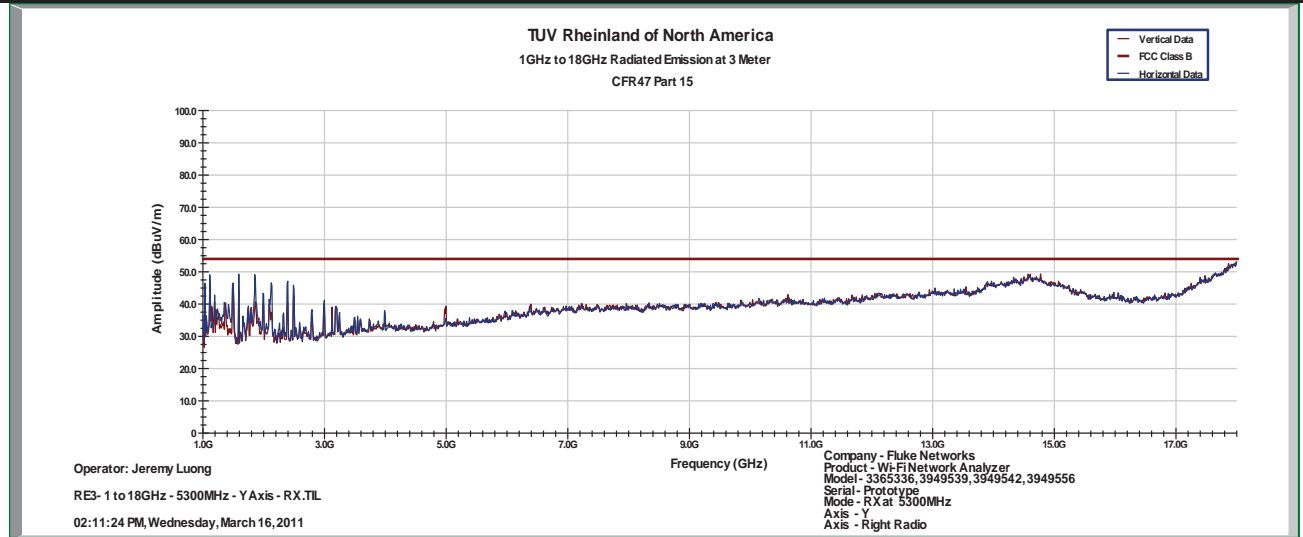

Notes: Tested with a Bandwidth of 20 MHz

SOP 1 Radiated Emissions

Tracking # 31053887.002 Page 6 of 14

EUT Name	OPTIVIEW XG, OPVXG, OPTIVIEW XG-10G, OPVXG-10G, OPVXGPRO, OPVXG-EXPT, OPTIVIEW XG-LAN, OPVXG-LAN, OPVXG-LAN-10G, OPTIVIEW XG WLAN, OPVXG-WLAN	Date	March 18, 2011
EUT Model	3365336, 3949539, 3949542, 3949556, 3949616, 4020634	Temp / Hum in	21°C / 39%rh
EUT Serial	Prototype	Temp / Hum out	N/A
EUT Config.	Y-Axis, RX at 5300 MHz	Line AC	120Vac 60Hz
Standard	CFR47 Part 15 Subpart b	RBW / VBW	1 MHz / 3MHz
Dist/Ant Used	1m - RA28-K-F-4B-C	Performed by	Jeremy Luong

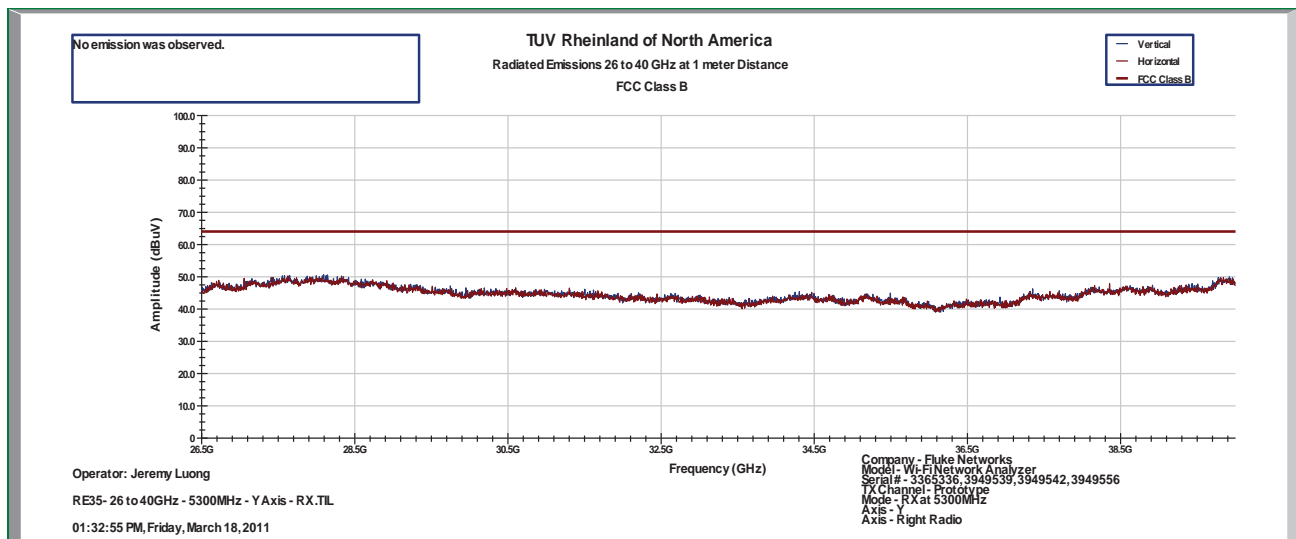

Notes: Tested with a Bandwidth of 20 MHz

SOP 1 Radiated Emissions

Tracking # 31053887.002 Page 7 of 14

EUT Name	OPTIVIEW XG, OPVXG, OPTIVIEW XG-10G, OPVXG-10G, OPVXGPRO, OPVXG-EXPT, OPTIVIEW XG-LAN, OPVXG-LAN, OPVXG-LAN-10G, OPTIVIEW XG WLAN, OPVXG-WLAN	Date	March 18, 2011
EUT Model	3365336, 3949539, 3949542, 3949556, 3949616, 4020634	Temp / Hum in	21°C / 39%rh
EUT Serial	Prototype	Temp / Hum out	N/A
EUT Config.	Y-Axis, RX at 5600 MHz	Line AC	120Vac 60Hz
Standard	CFR47 Part 15 Subpart b	RBW / VBW	120 kHz / 300 kHz
Dist/Ant Used	3m - EMCO3115 / 1m - RA42-K-F-4B-C	Performed by	Jeremy Luong

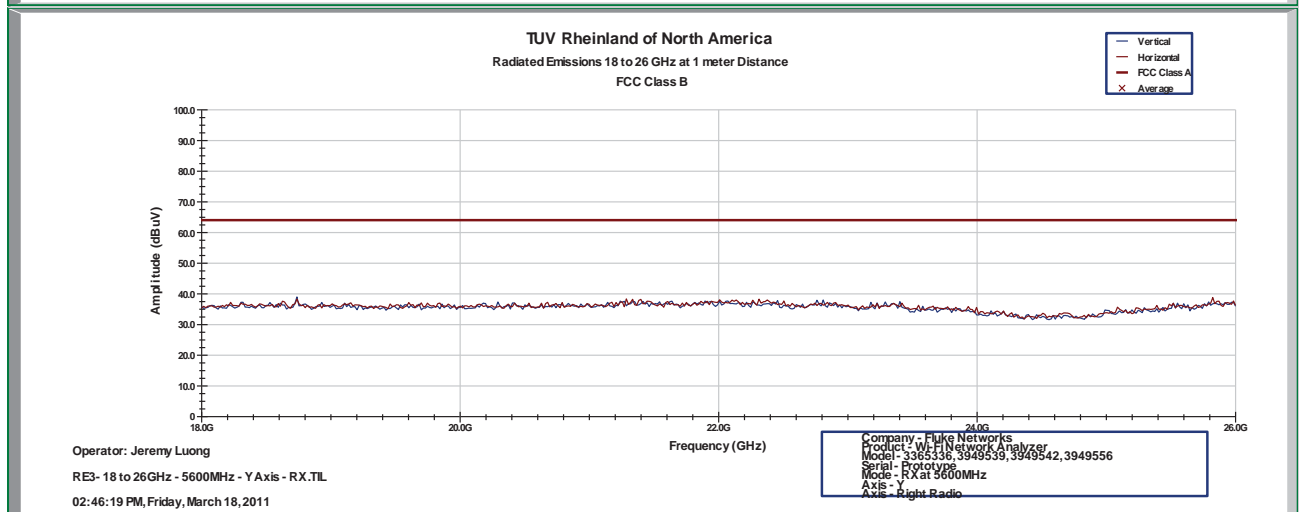
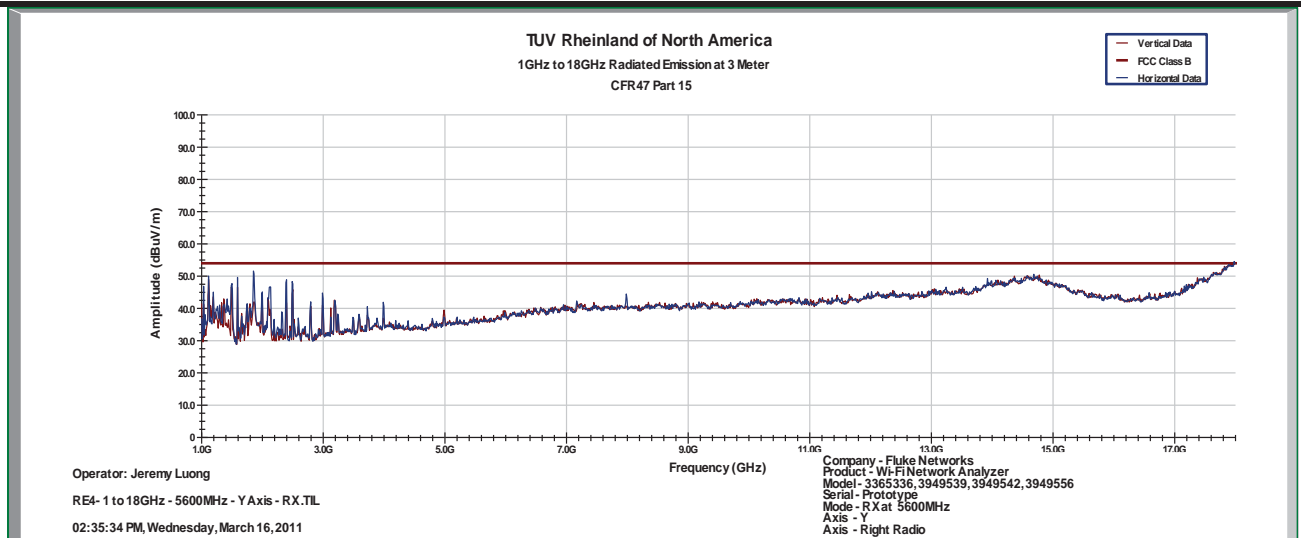

Notes: Tested with a Bandwidth of 20 MHz

SOP 1 Radiated Emissions

Tracking # 31053887.002 Page 8 of 14

EUT Name	OPTIVIEW XG, OPVXG, OPTIVIEW XG-10G, OPVXG-10G, OPVXGPRO, OPVXG-EXPT, OPTIVIEW XG-LAN, OPVXG-LAN, OPVXG-LAN-10G, OPTIVIEW XG WLAN, OPVXG-WLAN	Date	March 18, 2011
EUT Model	3365336, 3949539, 3949542, 3949556, 3949616, 4020634	Temp / Hum in	21°C / 39%rh
EUT Serial	Prototype	Temp / Hum out	N/A
EUT Config.	Y-Axis, RX at 5600 MHz	Line AC	120Vac 60Hz
Standard	CFR47 Part 15 Subpart b	RBW / VBW	1 MHz / 3MHz
Dist/Ant Used	1m - RA28-K-F-4B-C	Performed by	Jeremy Luong

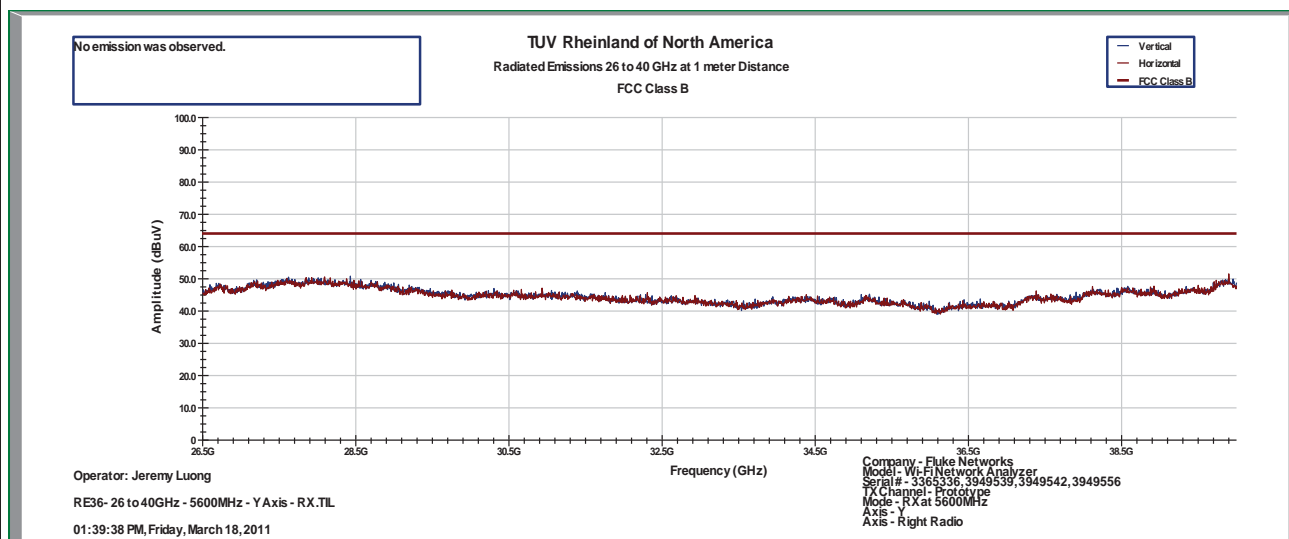

Notes: Tested with a Bandwidth of 20 MHz

SOP 1 Radiated Emissions

Tracking # 31053887.002 Page 9 of 14

EUT Name	OPTIVIEW XG, OPVXG, OPTIVIEW XG-10G, OPVXG-10G, OPVXGPRO, OPVXG-EXPT, OPTIVIEW XG-LAN, OPVXG-LAN, OPVXG-LAN-10G, OPTIVIEW XG WLAN, OPVXG-WLAN	Date	March 18, 2011
EUT Model	3365336, 3949539, 3949542, 3949556, 3949616, 4020634	Temp / Hum in	21°C / 39%rh
EUT Serial	Prototype	Temp / Hum out	N/A
EUT Config.	Y-Axis, RX at 5230 MHz	Line AC	120Vac 60Hz
Standard	CFR47 Part 15 Subpart b	RBW / VBW	120 kHz / 300 kHz
Dist/Ant Used	3m - EMCO3115 / 1m - RA42-K-F-4B-C	Performed by	Jeremy Luong

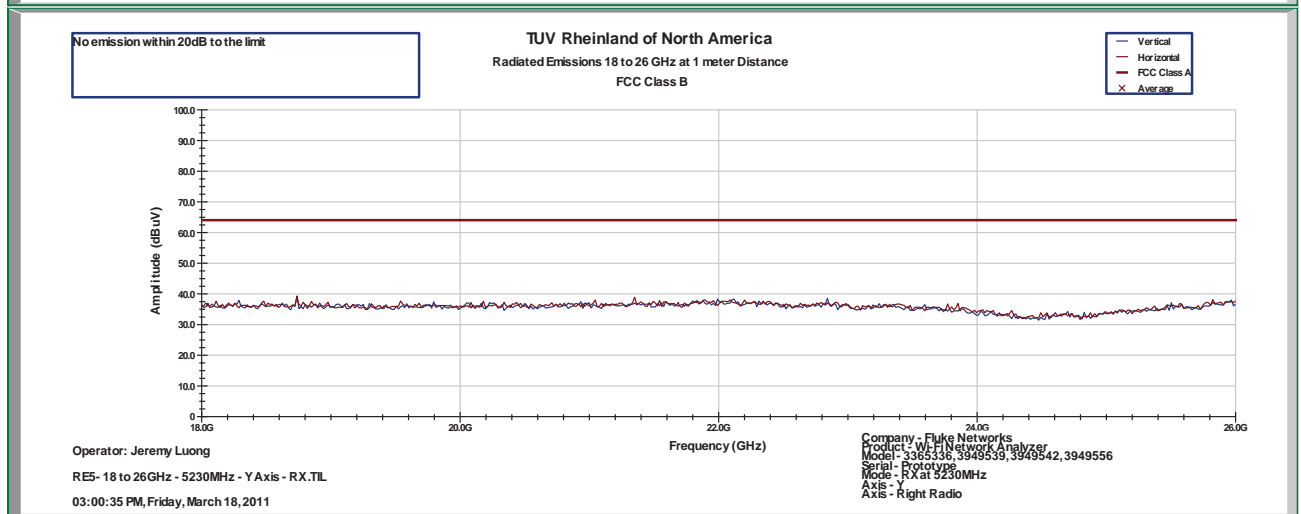
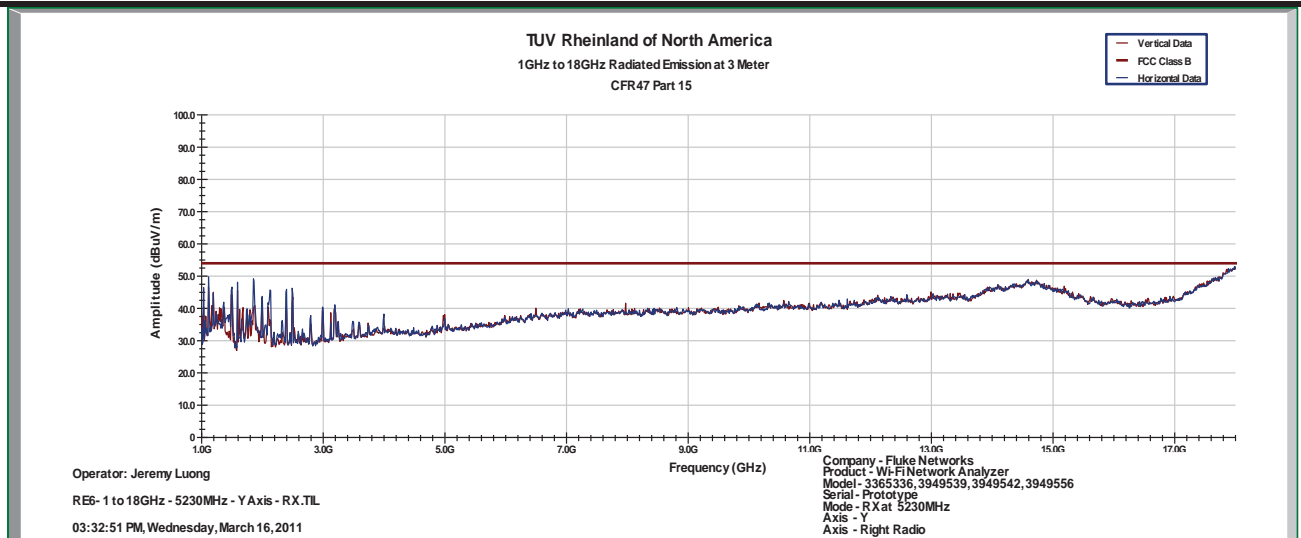

Notes: Tested with a Bandwidth of 40 MHz

SOP 1 Radiated Emissions

Tracking # 31053887.002 Page 10 of 14

EUT Name	OPTIVIEW XG, OPVXG, OPTIVIEW XG-10G, OPVXG-10G, OPVXGPRO, OPVXG-EXPT, OPTIVIEW XG-LAN, OPVXG-LAN, OPVXG-LAN-10G, OPTIVIEW XG WLAN, OPVXG-WLAN	Date	March 18, 2011
EUT Model	3365336, 3949539, 3949542, 3949556, 3949616, 4020634	Temp / Hum in	21°C / 39%rh
EUT Serial	Prototype	Temp / Hum out	N/A
EUT Config.	Y-Axis, RX at 5230 MHz	Line AC	120Vac 60Hz
Standard	CFR47 Part 15 Subpart b	RBW / VBW	1 MHz / 3MHz
Dist/Ant Used	1m - RA28-K-F-4B-C	Performed by	Jeremy Luong

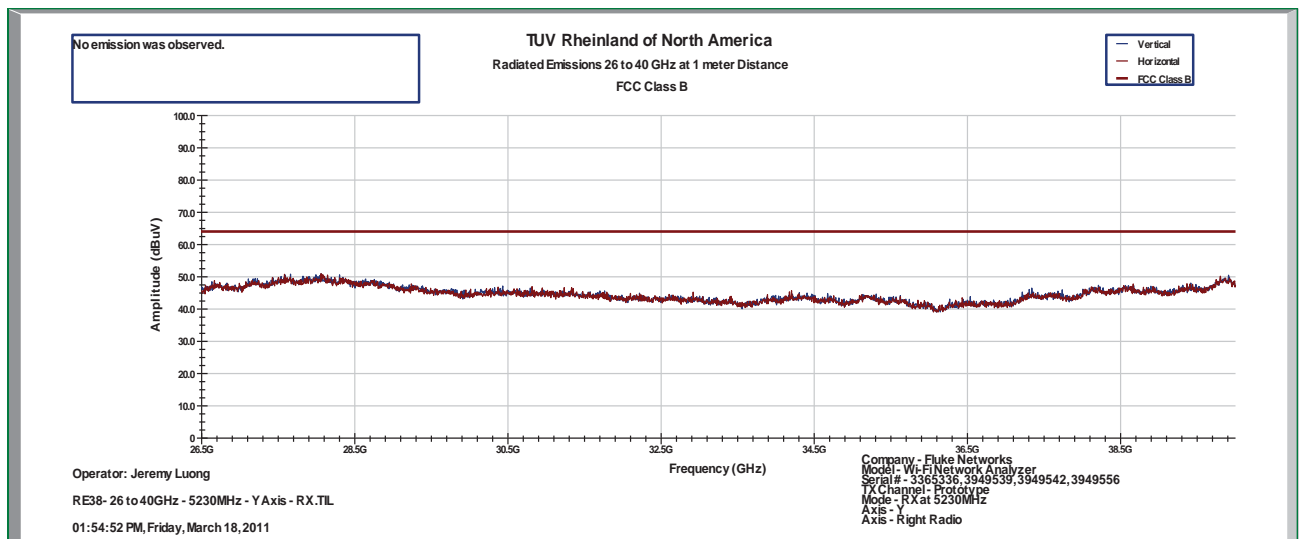

Notes: Tested with a Bandwidth of 40 MHz

SOP 1 Radiated Emissions

Tracking # 31053887.002 Page 11 of 14

EUT Name	OPTIVIEW XG, OPVXG, OPTIVIEW XG-10G, OPVXG-10G, OPVXGPRO, OPVXG-EXPT, OPTIVIEW XG-LAN, OPVXG-LAN, OPVXG-LAN-10G, OPTIVIEW XG WLAN, OPVXG-WLAN	Date	March 18, 2011
EUT Model	3365336, 3949539, 3949542, 3949556, 3949616, 4020634	Temp / Hum in	21°C / 39%rh
EUT Serial	Prototype	Temp / Hum out	N/A
EUT Config.	Y-Axis, RX at 5310 MHz	Line AC	120Vac 60Hz
Standard	CFR47 Part 15 Subpart b	RBW / VBW	120 kHz / 300 kHz
Dist/Ant Used	3m - EMCO3115 / 1m - RA42-K-F-4B-C	Performed by	Jeremy Luong

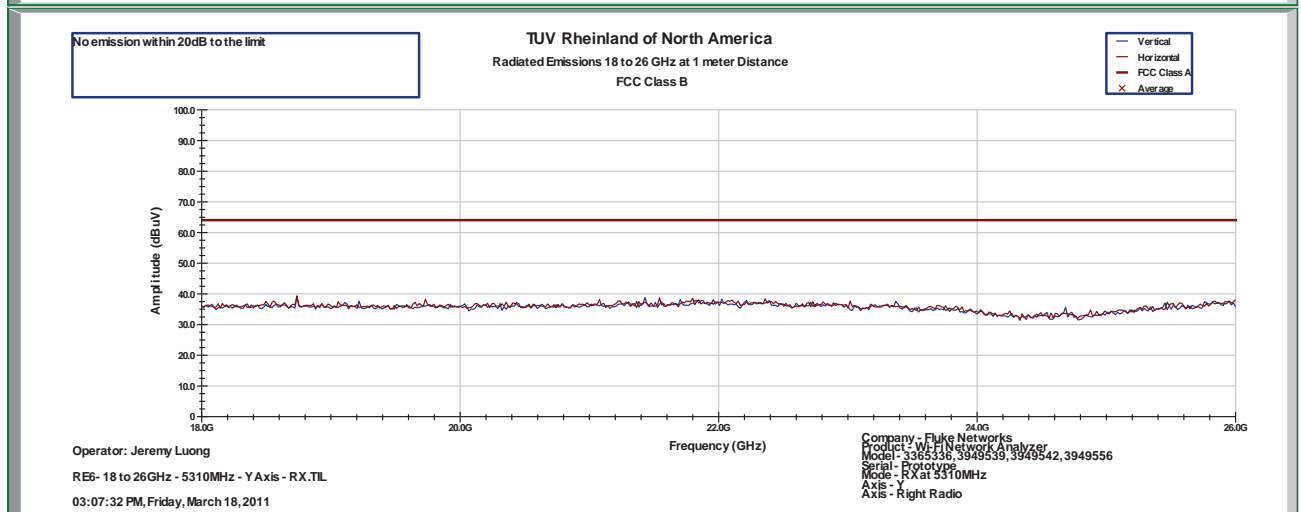
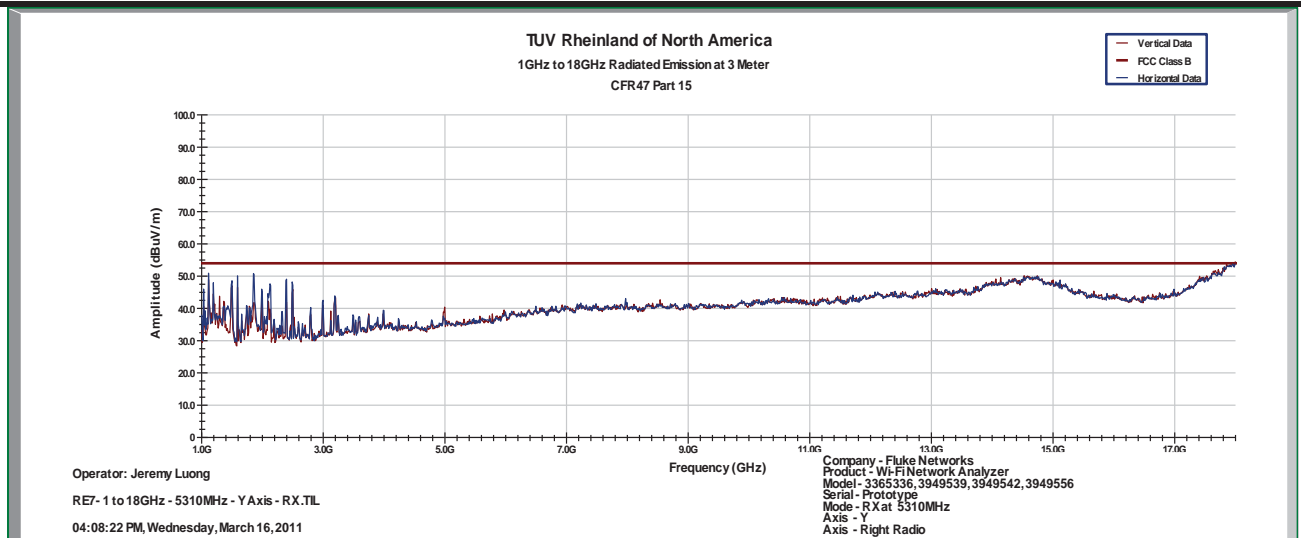

Notes: Tested with a Bandwidth of 40 MHz

SOP 1 Radiated Emissions

Tracking # 31053887.002 Page 12 of 14

EUT Name	OPTIVIEW XG, OPVXG, OPTIVIEW XG-10G, OPVXG-10G, OPVXGPRO, OPVXG-EXPT, OPTIVIEW XG-LAN, OPVXG-LAN, OPVXG-LAN-10G, OPTIVIEW XG WLAN, OPVXG-WLAN	Date	March 18, 2011
EUT Model	3365336, 3949539, 3949542, 3949556, 3949616, 4020634	Temp / Hum in	21°C / 39%rh
EUT Serial	Prototype	Temp / Hum out	N/A
EUT Config.	Y-Axis, RX at 5310 MHz	Line AC	120Vac 60Hz
Standard	CFR47 Part 15 Subpart b	RBW / VBW	1 MHz / 3MHz
Dist/Ant Used	1m - RA28-K-F-4B-C	Performed by	Jeremy Luong

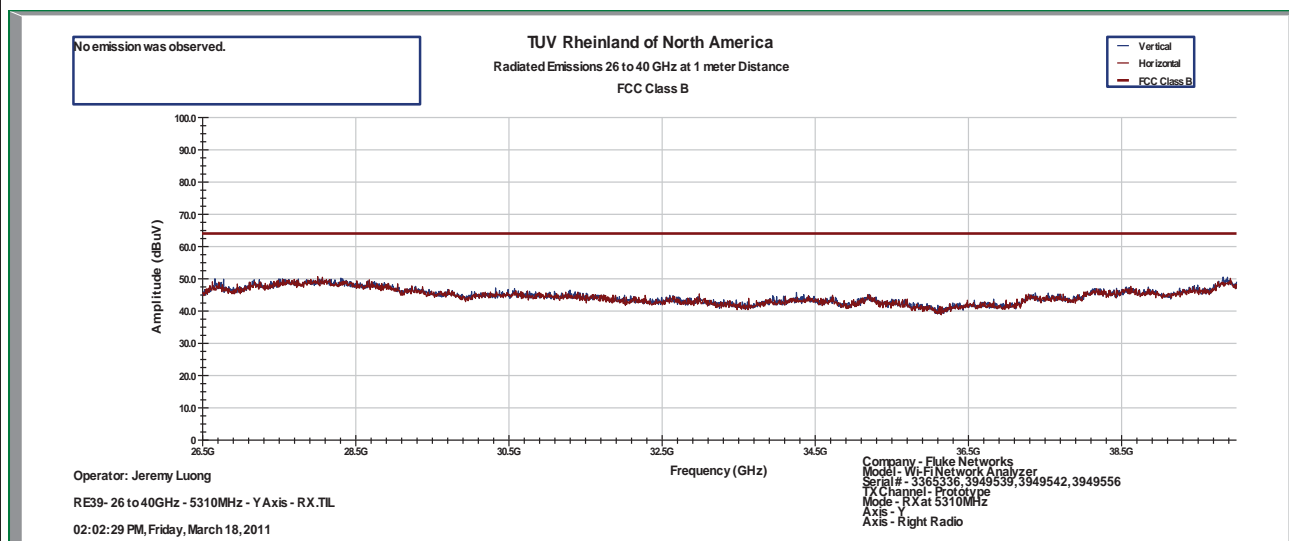

Notes: Tested with a Bandwidth of 40 MHz

SOP 1 Radiated Emissions

Tracking # 31053887.002 Page 13 of 14

EUT Name	OPTIVIEW XG, OPVXG, OPTIVIEW XG-10G, OPVXG-10G, OPVXGPRO, OPVXG-EXPT, OPTIVIEW XG-LAN, OPVXG-LAN, OPVXG-LAN-10G, OPTIVIEW XG WLAN, OPVXG-WLAN	Date	March 18, 2011
EUT Model	3365336, 3949539, 3949542, 3949556, 3949616, 4020634	Temp / Hum in	21°C / 39%rh
EUT Serial	Prototype	Temp / Hum out	N/A
EUT Config.	Y-Axis, RX at 5590 MHz	Line AC	120Vac 60Hz
Standard	CFR47 Part 15 Subpart b	RBW / VBW	120 kHz / 300 kHz
Dist/Ant Used	3m - EMCO3115 / 1m - RA42-K-F-4B-C	Performed by	Jeremy Luong

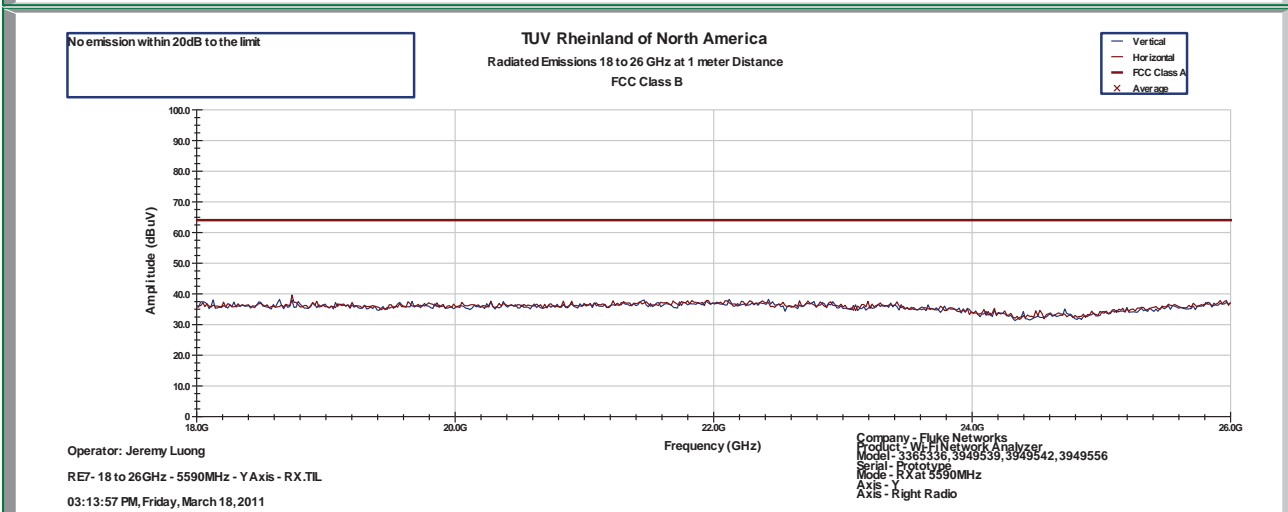
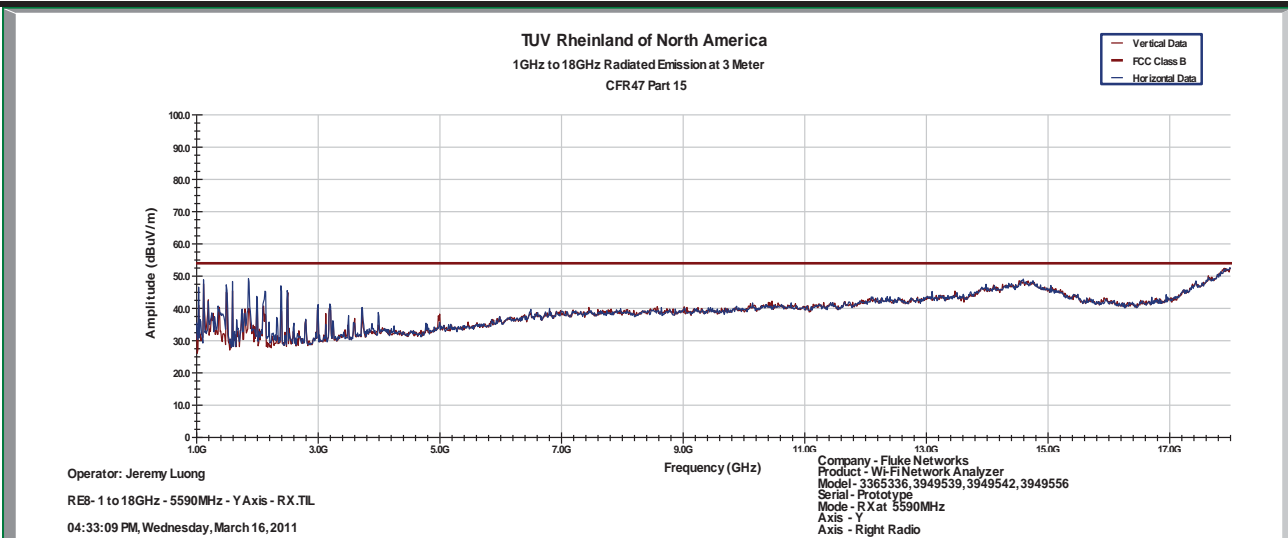

Notes: Tested with a Bandwidth of 40 MHz

SOP 1 Radiated Emissions Tracking # 31053887.002 Page 14 of 14

EUT Name	OPTIVIEW XG, OPVXG, OPTIVIEW XG-10G, OPVXG-10G, OPVXGPRO, OPVXG-EXPT, OPTIVIEW XG-LAN, OPVXG-LAN, OPVXG-LAN-10G, OPTIVIEW XG WLAN, OPVXG-WLAN	Date	March 18, 2011
EUT Model	3365336, 3949539, 3949542, 3949556, 3949616, 4020634	Temp / Hum in	21°C / 39%rh
EUT Serial	Prototype	Temp / Hum out	N/A
EUT Config.	Y-Axis, RX at 5590 MHz	Line AC	120Vac 60Hz
Standard	CFR47 Part 15 Subpart b	RBW / VBW	1 MHz / 3MHz
Dist/Ant Used	1m - RA28-K-F-4B-C	Performed by	Jeremy Luong

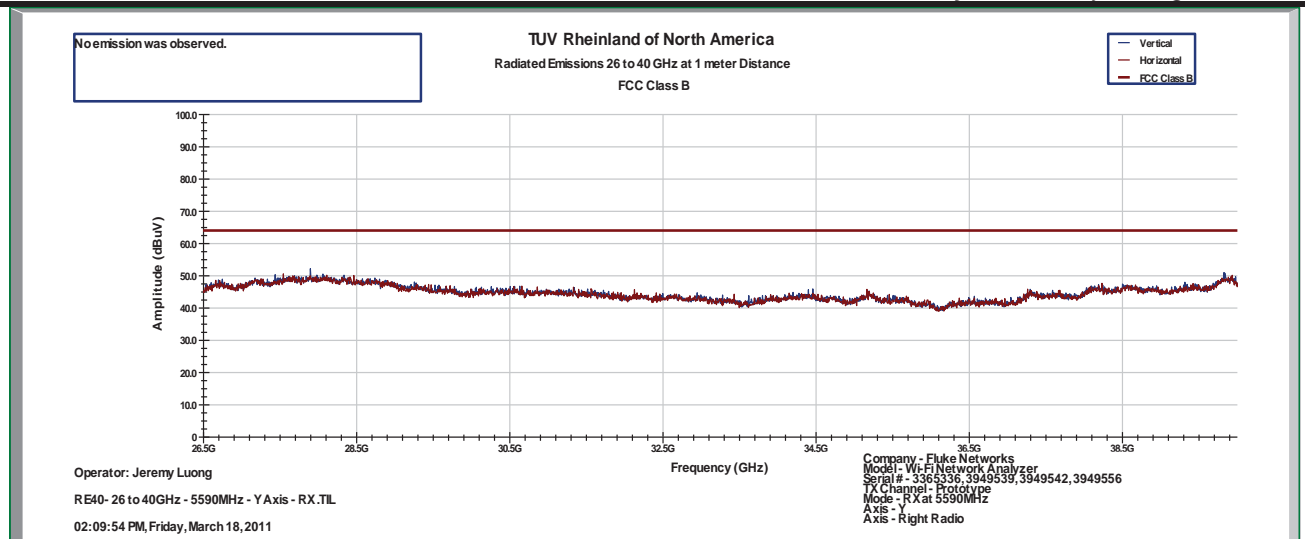

Notes: Tested with a Bandwidth of 40 MHz

4.6.4 Sample Calculation

The field strength is calculated by subtracting the Amplifier Gain and adding the Cable Loss and Antenna Correction Factor to the measured reading. The basic equation is as follows:

$$\text{Field Strength (dB}\mu\text{V/m)} = \text{FIM} - \text{AMP} + \text{CBL} + \text{ACF}$$

- Where:
- FIM = Field Intensity Meter (dB μ V)
 - AMP = Amplifier Gain (dB)
 - CBL = Cable Loss (dB)
 - ACF = Antenna Correction Factor (dB/m)

$$\mu\text{V/m} = 10^{\frac{\text{dB}\mu\text{V} / \text{m}}{20}}$$

4.7 AC Conducted Emissions

Testing was performed in accordance with ANSI C63.4: 2003. These test methods are listed under the laboratory's NVLAP Scope of Accreditation.

This test measures the levels emanating from the EUT's AC input port, thus evaluating the potential for the EUT to cause radio frequency interference to other electronic devices.

The AC conducted emissions of equipment under test shall not exceed the values in CFR47 Part 15.207: 2009 and RSS 210: 2010.

4.7.1 Test Methodology

A test program that controls instrumentation and data logging was used to automate the AC Power Line Conducted emission test procedure. The frequency range of interest was divided into sub-ranges such as to yield a frequency resolution of 9 kHz. Each phase and neutral of the AC power line were measured with respect to ground. Measurements were performed using a set of 50µH / 50Ω LISNs.

Testing is either performed in Lab 5. The setup photographs clearly identify which site was used. The vertical ground plane used in the semi-anechoic chamber is a 2m x 2m solid aluminum frame and panel, and it is bonded to the horizontal ground plane.

In the case of tabletop equipment, the EUT is placed on a 1.0m x 1.5m non-conductive table 80cm above the ground plane and 40cm from a vertical ground reference plane. The rear of the EUT was positioned flush with the backside of the table and directly over the LISNs. The power and I/O cables were routed over the edge of the table and bundled approximately 40cm from the ground plane. Support equipment was powered from a separate LISN.

4.7.1.1 Deviations

There were no deviations from this test methodology.

4.7.2 Test Results

As originally tested, the EUT was found to be compliant to the requirements of the test standard(s).

Table 7: AC Conducted Emissions – Test Results

Test Conditions: Conducted Measurement at Normal Conditions only		
Antenna Type: Attached	Power Level: See Test Plan	
AC Power: 120 Vac/60 Hz	Configuration: Tabletop	
Ambient Temperature: 22° C	Relative Humidity: 37% RH	
Configuration	Frequency Range	Test Result
Line 1 (Hot)	0.15 to 30 MHz	Pass

Line 2 (Neutral)	0.15 to 30 MHz	Pass
------------------	----------------	------

Frequency	Quasi-Peak	QP Limit	QP Margin	Average	Ave Limit	Ave Margin
MHz	dBuV	dBuV	dB	dBuV	dBuV	dB
0.1500	50.51	66.00	-15.49	33.66	56.00	-22.34
0.1502	50.82	65.99	-15.17	33.44	55.99	-22.55
0.1975	31.75	64.64	-32.89	2.65	54.64	-51.99
0.1977	31.37	64.64	-33.27	2.76	54.64	-51.88
10.0201	27.99	60.00	-32.01	21.98	50.00	-28.02
10.8684	38.25	60.00	-21.75	32.02	50.00	-17.98
11.0218	38.65	60.00	-21.35	32.69	50.00	-17.31
15.1377	39.70	60.00	-20.30	34.04	50.00	-15.96
15.6255	40.57	60.00	-19.43	34.92	50.00	-15.08
27.2380	36.28	60.00	-23.72	30.65	50.00	-19.35

Spec Margin = QP./Ave. - Limit, ± Uncertainty
 Combined Standard Uncertainty $u_c(y) = \pm 1.2$ dB Expanded Uncertainty $U = ku_c(y)$ $k = 2$ for 95% confidence
 Notes: EUT was setup as table top equipment and transmitted at 5300 MHz in HT20 at 6.5Mbps

SOP 2 Conducted Emissions

Tracking # 31053887.002 Page 2 of 4

EUT Name	OPTIVIEW XG, OPVXG, OPTIVIEW XG-10G, OPVXG-10G, OPVXGPRO, OPVXG-EXPT, OPTIVIEW XG-LAN, OPVXG-LAN, OPVXG-LAN-10G, OPTIVIEW XG WLAN, OPVXG-WLAN	Date	March 10, 2011
EUT Model	3365336, 3949539, 3949542, 3949556, 3949616, 4020634	Temp / Hum in	23° C / 34% rh
EUT Serial	221029024922	Temp / Hum out	N/A
EUT Config.	Attached Antenna	Line AC	120Vac/60Hz
Standard	CFR47 Part 15.207	RBW / VBW	9kHz / 30 kHz
Lab/LISN	Lab #5 / Solar 9348-50-R-24-BNC, Line 1	Performed by	Jeremy Luong

150 kHz to 30 MHz Plot for Line 1 (Hot)

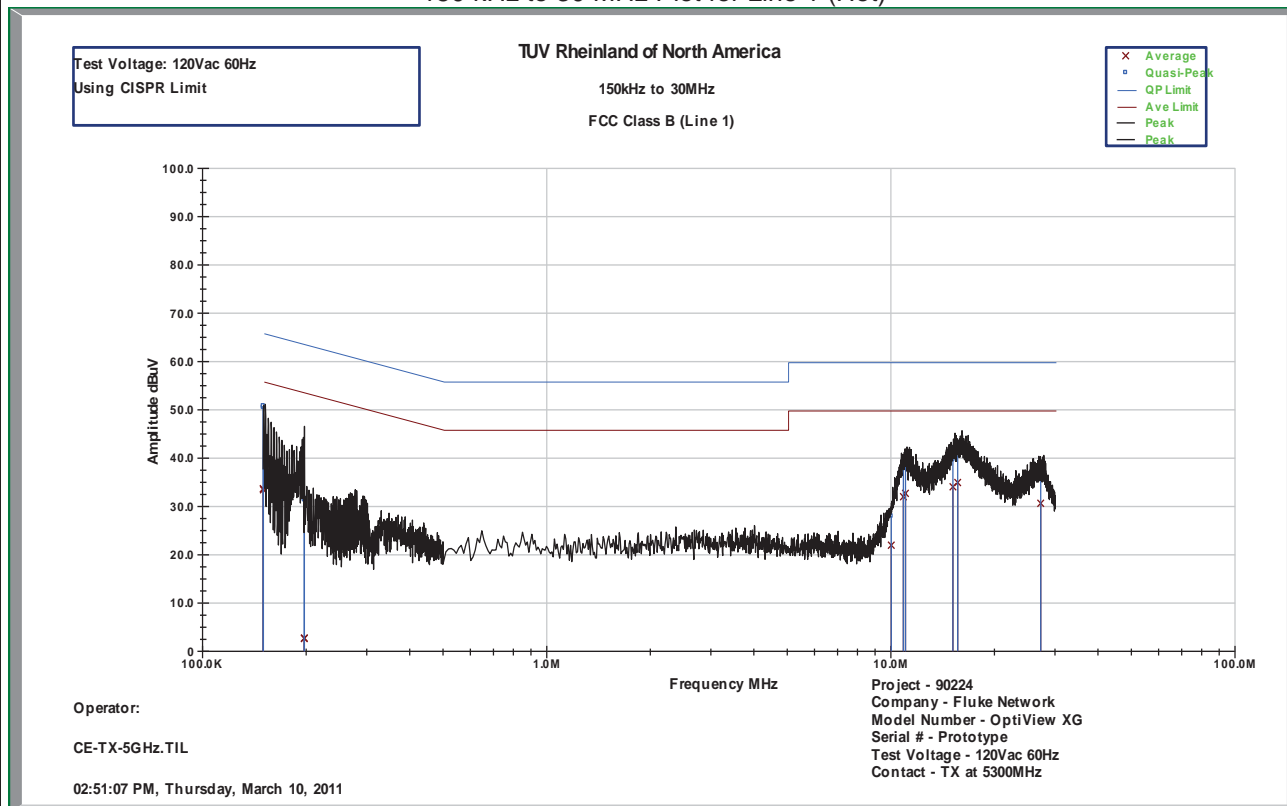

Notes: Meet FCC Class B limit.

SOP 2 Conducted Emissions				Tracking # 31053887.002 Page 3 of 4		
EUT Name	OPTIVIEW XG, OPVXG, OPTIVIEW XG-10G, OPVXG-10G, OPVXGPRO, OPVXG-EXPT, OPTIVIEW XG-LAN, OPVXG-LAN, OPVXG-LAN-10G, OPTIVIEW XG WLAN, OPVXG-WLAN			Date	March 10, 2011	
EUT Model	3365336, 3949539, 3949542, 3949556, 3949616, 4020634			Temp / Hum in	23° C / 34% rh	
EUT Serial	221029024922			Temp / Hum out	N/A	
EUT Config.	Attached Antenna			Line AC / Freq	120Vac/60Hz	
Standard	CFR47 Part 15.107			RBW / VBW	9kHz / 30 kHz	
Lab/LISN	Lab #5 / Solar 9348-50-R-24-BNC, Line 2			Performed by	Jeremy Luong	
Frequency	Quasi-Peak	QP Limit	QP Margin	Average	Ave Limit	Ave Margin
MHz	dBuV	dBuV	dB	dBuV	dBuV	dB
0.1501	52.05	66.00	-13.95	34.43	56.00	-21.57
0.1504	51.69	65.99	-14.30	34.06	55.99	-21.94
0.1949	42.93	64.72	-21.79	35.42	54.72	-19.30
0.1951	41.84	64.71	-22.87	35.32	54.71	-19.39
0.1955	41.34	64.70	-23.36	34.85	54.70	-19.85
9.9849	29.66	60.00	-30.34	23.58	50.00	-26.42
11.0920	40.51	60.00	-19.49	34.42	50.00	-15.58
11.1906	40.32	60.00	-19.68	34.25	50.00	-15.75
11.4882	38.81	60.00	-21.19	32.50	50.00	-17.50
15.4466	38.27	60.00	-21.73	32.72	50.00	-17.28
20.7332	29.69	60.00	-30.31	24.38	50.00	-25.62
Spec Margin = QP./Ave. - Limit, ± Uncertainty						
Combined Standard Uncertainty $u_c(y) = \pm 1.2$ dB Expanded Uncertainty $U = ku_c(y)$ $k = 2$ for 95% confidence						
Notes: EUT was setup as table top equipment and transmitted at 5300 MHz in HT20 at 6.5Mbps						

SOP 2 Conducted Emissions

Tracking # 31053887.002 Page 4 of 4

EUT Name	OPTIVIEW XG, OPVXG, OPTIVIEW XG-10G, OPVXG-10G, OPVXGPRO, OPVXG-EXPT, OPTIVIEW XG-LAN, OPVXG-LAN, OPVXG-LAN-10G, OPTIVIEW XG WLAN, OPVXG-WLAN	Date	March 10, 2011
EUT Model	3365336, 3949539, 3949542, 3949556, 3949616, 4020634	Temp / Hum in	23° C / 34% rh
EUT Serial	221029024922	Temp / Hum out	N/A
EUT Config.	Attached Antenna	Line AC	120Vac/60Hz
Standard	CFR47 Part 15.107	RBW / VBW	9kHz / 30 kHz
Lab/LISN	Lab #5/ Solar 9348-50-R-24-BNC, Line 2	Performed by	Jeremy Luong

150 kHz to 30 MHz Plot for Line 2 (Neutral)

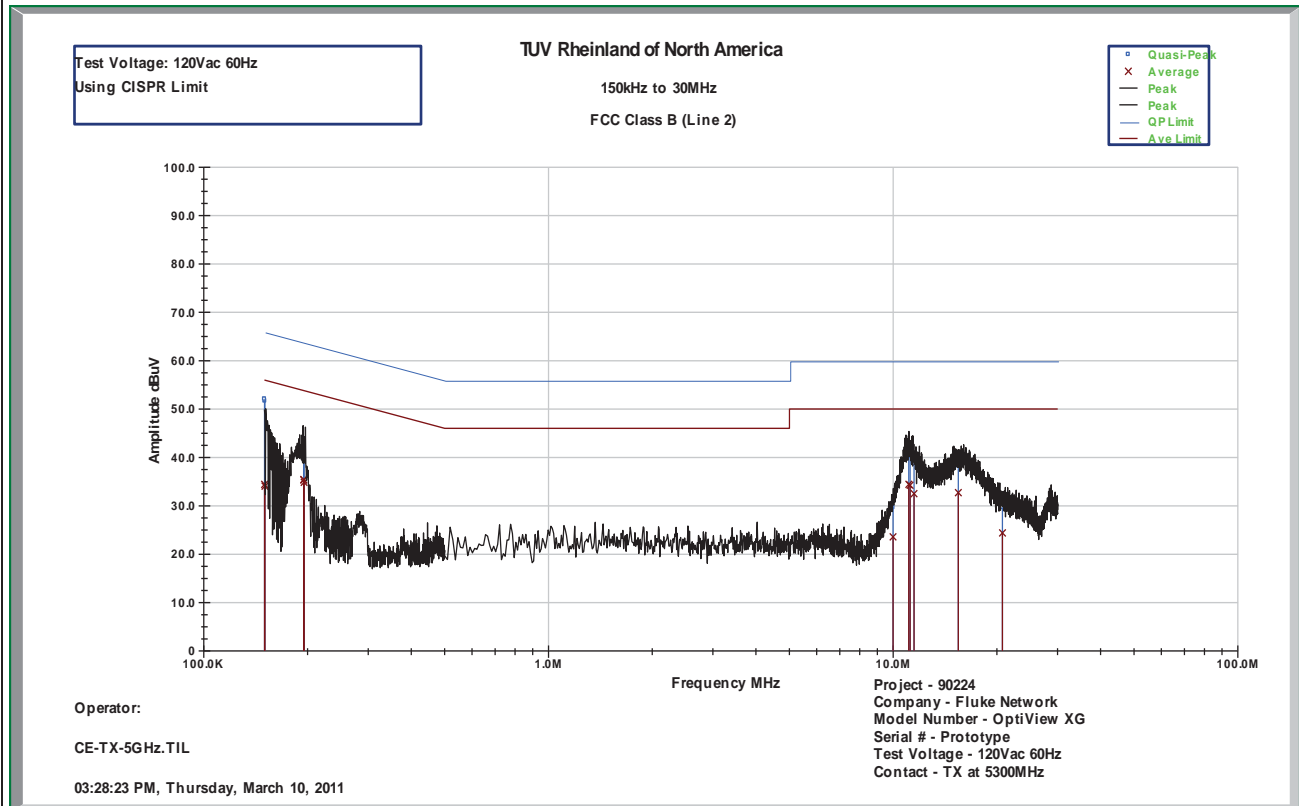

Note: Meet FCC Class B Limit.

4.8 Frequency Stability

In accordance with 47 CFR Part 15.407(g) the frequency stability of U-NII devices must be such that an emission is maintained within the band of operation under all conditions of normal operation as specified in the users manual. The Manufacturer calls out operating temperature ranges of +0° to +50° C

4.8.1 Test Methodology

The manufacturer of the equipment is responsible for ensuring that the frequency stability is such that emissions are always maintained within the band of operation under all conditions. This test performs according to ANSI C63.10-2009 Section 6.8

4.8.2 Manufacturer Declaration

The frequency stability of the reference oscillator sets the frequency stability of the RF transceiver signals. Therefore all of the RF signal should have ± 20 ppm stability.

This stability accounts for room temp tolerance of the crystal oscillator circuit, frequency variation across temperature, and crystal ageing.

Worst case:

5.320 GHz - ± 20 ppm/106.4 kHz

± 20 ppm at 5 GHz translates to a maximum frequency shift of ± 103 kHz. As the edge of the channels are at least one MHz from either of the band edges, ± 103 kHz is more than sufficient to guarantee that the intentional emission will remain in the band over the entire operating range of the radio.

4.8.3 Limit

CFR47 Part 407(g) - Manufacturers of U-NII devices are responsible for ensuring frequency stability such that an emission is maintained within the band of operation under all conditions of normal operation as specified in the users manual.

4.8.4 Test results

As originally tested, the EUT was found to be compliant to the requirements of the test standard(s).

Table 8: Frequency Stability – Test Results

Temperature	Time	-6 dB Lower Edge (MHz)	+6 dB Upper Edge (MHz)	Center Frequency (MHz)	PPM
50°C	Start	5319.8775	5320.0275	5319.9525	8.93
	2 Min.	5319.8819	5320.0306	5319.95625	8.22
	5 Min	5319.8819	5320.0326	5319.95725	8.04
	10 min	5319.8819	5320.0346	5319.95825	7.85
40°C	Start	5319.8914	5320.0386	5319.965	6.58
	2 Min.	5319.8824	5320.0276	5319.955	8.46
	5 Min	5319.8824	5320.0276	5319.955	8.46
	10 min	5319.8824	5320.0266	5319.9545	8.55
30°C	Start	5319.9215	5320.0716	5319.99655	0.65
	2 Min.	5319.9055	5320.0336	5319.96955	5.72
	5 Min	5319.8924	5320.0376	5319.965	6.58
	10 min	5319.8864	5320.0376	5319.962	7.14
20°C	Start	5319.9345	5320.0856	5320.01005	-1.89
	2 Min.	5319.9045	5320.0546	5319.97955	3.84
	5 Min	5319.9005	5320.0496	5319.97505	4.69
	10 min	5319.9005	5320.0496	5319.97505	4.69
10°C	Start	5319.9615	5320.1097	5320.0356	-6.69
	2 Min.	5319.9335	5320.0826	5320.00805	-1.51
	5 Min	5319.9265	5320.0766	5320.00155	-0.29
	10 min	5319.9255	5320.0756	5320.00055	-0.10
0°C	Start	5319.9775	5320.1277	5320.0526	-9.89
	2 Min.	5319.9565	5320.1077	5320.0321	-6.03
	5 Min	5319.9485	5320.0986	5320.02355	-4.43
	10 min	5319.9475	5320.0966	5320.02205	-4.14

Note: All frequency drifts were less than ± 20 ppm.

4.9 Voltage Variation

In accordance with 47 CFR Part 15.31 (e) intentional radiators, measurements of the variation of the input power or the radiated signal level of the fundamental frequency component of the emission, as appropriate, shall be performed with the supply voltage varied between 85% and 115% of the nominal rated supply voltage. For battery operated equipment, the equipment tests shall be performed using a new battery.

4.9.1 Test Methodology

The ac supply voltage was varied between 85% and 115% of the nominal rated supply voltage. The fundamental frequency was observed during the variation. The OptiView XG was powered 120V/60Hz by programmable power supply. The voltage was varied from 102Vac to 138Vac mean while the fundamental frequencies were observed and record for the maximum drift in ppm; part per millions.

4.9.2 Test results

As originally tested, the EUT was found to be compliant to the requirements of the test standard(s). The fundamental frequencies drifted less than ± 20 ppm.

Table 9: Voltage Variation – Test Results

Frequency MHz	Nominal (120Vac) MHz	Lo Voltage (102Vac) MHz	Hi Voltage (138Vac) MHz	Max Drift ppm
5180	5179.9585	5179.9750	5179.9650	8.01
5220	5219.9585	5219.9585	5224.9580	7.95
5240	5239.9585	5239.9575	5239.9585	8.11
5260	5259.9575	5259.9600	5259.9590	8.08
5300	5299.9585	5299.9592	5299.9585	7.83
5320	5319.9580	5319.9590	5319.9580	7.89
5500	5499.9560	5499.9560	5499.9570	8.00
5600	5599.9550	5599.9565	5599.9560	8.04
5700	5699.9560	5699.9555	5699.9570	7.81

5 Dynamic Frequency Selection

Testing was performed in accordance with CFR47 Part 15.407 (h). These test methods are listed under the laboratory's NVLAP Scope of Accreditation. This test measures and verifies the characteristics and probability of EUT to switch to different operating channel, once the radar signal is detected. Procedures described in FCC-06-96A1 were used.

5.1 DFS Applicability

All devices operated in the frequency range of 5250 MHz-5350 MHz and 5470 MHz-5725MHz must equip with the DFS mechanism. Base on the operational mode of 3365336, 3949539, 3949542, 3949556, 3949616, 4020634, the following requirements shall apply per FCC-06-96A1 procedures.

Table 10: Applicability of DFS Requirements Prior to Use of a Channel

Requirement	Operational Mode		
	Master	Client Without Radar Detection	Client With Radar Detection
Non-Occupancy Period	Yes	Not required	Yes
DFS Detection Threshold	Yes	Not required	Yes
Channel Availability Check Time	Yes	Not required	Not required
Uniform Spreading	Yes	Not required	Not required
U-NII Detection Bandwidth	Yes	Not required	Yes

Table 11: Applicability of DFS requirements during normal operation

Requirement	Operational Mode		
	Master	Client w/o Radar Detection	Client With Radar Detection
DFS Detection Threshold	Yes	Not required	Yes
Channel Closing Transmission Time	Yes	Yes	Yes
Channel Move Time	Yes	Yes	Yes
U-NII Detection Bandwidth	Yes	Not required	Yes

5.2 DFS Requirements

Base on the applicability of 3365336, 3949539, 3949542, 3949556, 3949616, 4020634, the following parameters and probability must be tested for conformance.

Table 12: DFS Detection Thresholds for Master Devices and Client Devices With Radar Detection

Maximum Transmit Power	Value
≥ 200 milliwatt	-64 dBm
< 200 milliwatt	-62 dBm

Note 1: This is the level at the input of the receiver assuming a 0 dBi receive antenna.
 Note 2: Throughout these test procedures an additional 1 dB has been added to the amplitude of the test transmission waveforms to account for variations in measurement equipment. This will ensure that the test signal is at or above the detection threshold level to trigger a DFS response.

Table 13: DFS Response Requirement Values

Parameter	Value
Non-occupancy period	Minimum 30 minutes
Channel Availability Check Time	60 seconds
Channel Move Time	10 seconds. See Note 1.
Channel Closing Transmission Time	200 milliseconds + an aggregate of 60 milliseconds over remaining 10 second period. See Notes 1 and 2.
U-NII Detection Bandwidth	Minimum 80% of the U-NII 99% transmission power bandwidth. See Note 3.

Note 1: The instant that the Channel Move Time and the Channel Closing Transmission Time begins is as follows:

- For the Short Pulse Radar Test Signals this instant is the end of the *Burst*.
- For the Frequency Hopping radar Test Signal, this instant is the end of the last radar Burst generated.
- For the Long Pulse Radar Test Signal this instant is the end of the 12 second period defining the Radar Waveform.

Note 2: The Channel Closing Transmission Time is comprised of 200 milliseconds starting at the beginning of the Channel Move Time plus any additional intermittent control signals required to facilitate a Channel move (an aggregate of 60 milliseconds) during the remainder of the 10 second period. The aggregate duration of control signals will not count quiet periods in between transmissions.

Note 3: During the U-NII Detection Bandwidth detection test, radar type 1 is used and for each frequency step the minimum percentage of detection is 90 percent. Measurements are performed with no data traffic.

Table 14: Short Pulse Radar Test Waveforms

Radar Type	Pulse Width (µsec)	PRI (µsec)	Number of Pulses	Minimum Percentage of Successful Detection	Minimum Number of Trials
1	1	1428	18	60%	30
2	1-5	150-230	23-29	60%	30
3	6-10	200-500	16-18	60%	30
4	11-20	200-500	12-16	60%	30
Aggregate (Radar Types 1-4)				80%	120

Table 15: Long Pulse Radar Test Waveform

Radar Type	Pulse Width (µsec)	Chirp Width (MHz)	PRI (µsec)	Number of Pulses per Burst	Number of Bursts	Minimum Percentage of Successful Detection	Minimum Number of Trials
5	50-100	5-20	1000-2000	1-3	8-20	80%	30

Table 16: Frequency Hopping Radar Test Waveform

Radar Type	Pulse Width (µsec)	PRI (µsec)	Pulses per Hop	Hopping Rate (kHz)	Hopping Sequence Length (msec)	Minimum Percentage of Successful Detection	Minimum Number of Trials
6	1	333	9	0.333	300	70%	30

5.3 Test Setup Protocol

The following test setup was used to evaluate the OPTIVIEW XG, OPVXG, OPTIVIEW XG-10G, OPVXG-10G, OPVXGPRO, OPVXG-EXPT, OPTIVIEW XG-LAN, OPVXG-LAN, OPVXG-LAN-10G, OPTIVIEW XG WLAN, OPVXG-WLAN for DFS conformance.

Dynamic Frequency Selection in Conducted Setup:

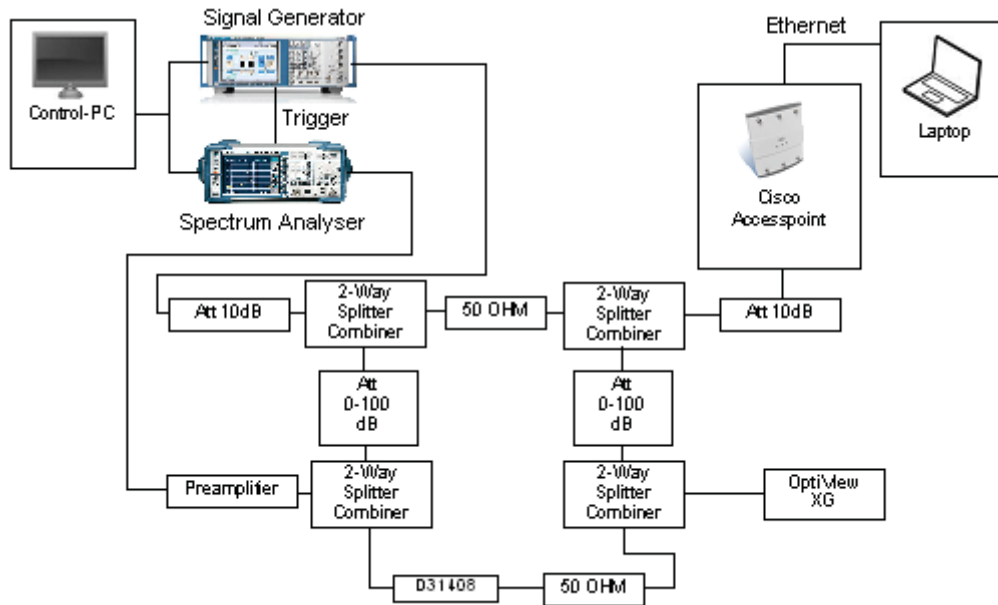

Dynamic Frequency Selection in Block Diagram:

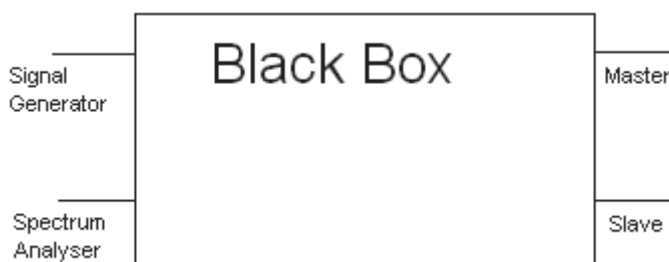

5.4 Radar Waveform Verifications

The radar signal level must be -60 dBm (-64 dBm+ 3dB +1dB).

Note: 3dB min. Antenna Gain of the Cisco Access Point

1dB is added to insure that the Radar-Injection-Level is above the AP-Detection-Threshold-Level

These waveforms were compensated for the path loss as offset on spectrum analyzer.

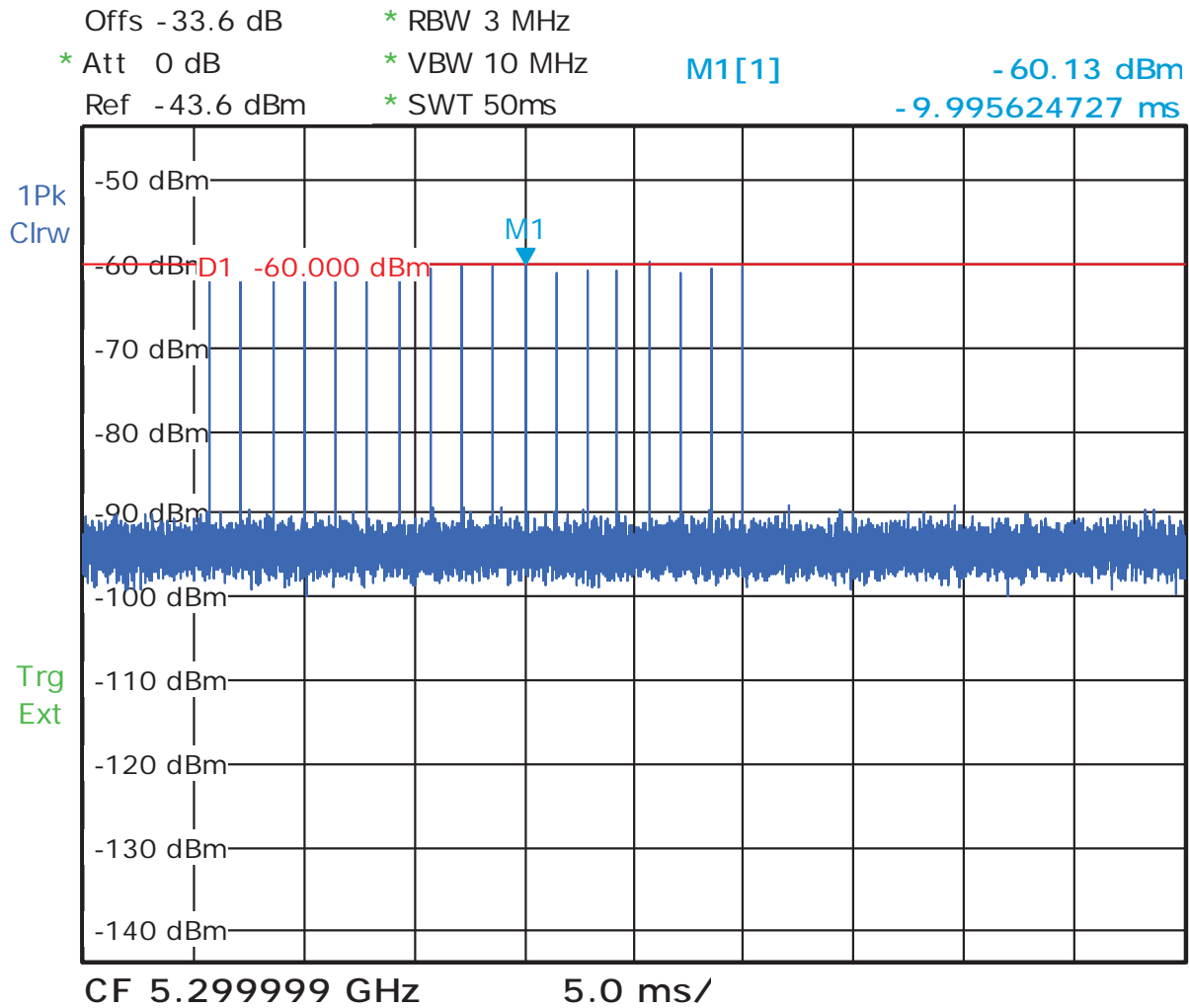

Date: 4.APR.2011 09:35:37

Figure 641: 5300 MHz Radar Pulse Type 1 at Master

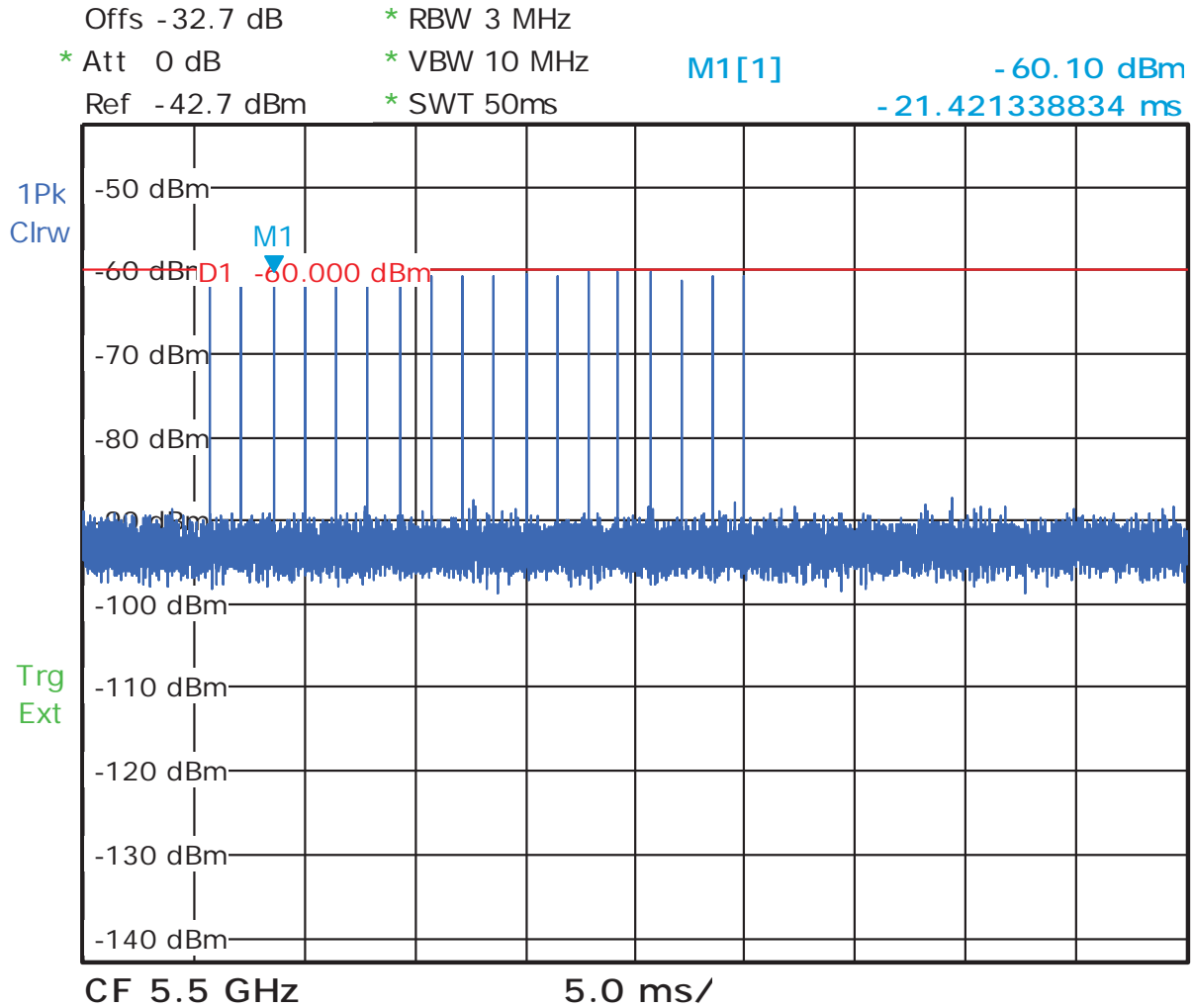

Date: 4.APR.2011 09:43:27

Figure 642: 5500 MHz Radar Pulse Type 1 at Master

5.5 In-Service Monitoring

In-service monitoring performance checks consist of the channel move time, channel closing transmission time, and non-occupancy period. These parameters of the OptiView XG are verified to give the radar system the priority of the frequency band and minimize the interference with nearby radar systems when the OptiView XG is being used.

The OptiView XG is a client device without any radar detection.

The verified Pulse #1 was conductively injected to the above test circuit. Since Cisco AP was qualified for DFS, the OptiView XG was evaluated with the Cisco AP as a whole network system for conformance to the channel move time and channel closing transmission time.

As originally tested, the OptiView XG was found to be compliant to the requirements of the test standard(s).

Table 17: DFS Response – Test Results

Test Method: Conducted					
Center Frequency: see below.		EUT State: Streaming MPEG Video			
Min. Antenna Gain: 3.2dB		Max. Transmitted Power: nominal			
Required Threshold: -64dBm		Detection Threshold: -60 dBm			
Ambient Temperature: 21° C		Relative Humidity: 38 RH%			
Bandwidth (MHz)	Channel (MHz)	CMT (sec)	CCTT (msec)	Figure	Results
20	5260	8.26	202	643	Complies
20	5300	0.46	202	644	Complies
20	5500	8.38	206	645	Complies
20	5540	8.31	204	646	Complies
20	5560	0.49	202	647	Complies
40	5310	0.54	203	648	Complies
40	5320	0.48	202	649	Complies
40	5680	0.51	202	650	Complies
<p>Note: Different frequencies were evaluated due to the Cisco AP auto channel selection.</p> <p><i>CCTT= Channel Closing Transmission Time.</i></p> <p><i>CMT= Channel Move Time</i></p>					

5.5.1 Bandwidth of 20 MHz

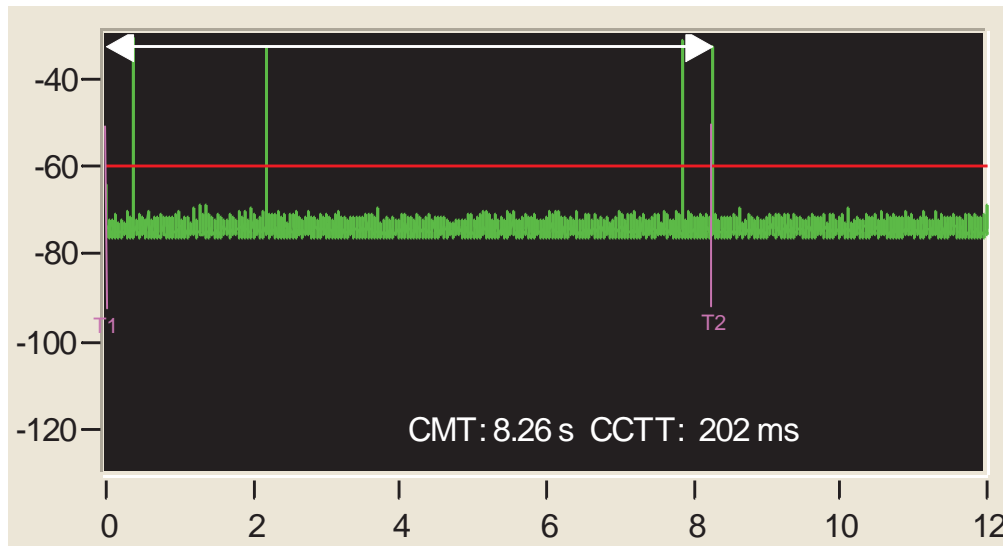

Figure 643: Channel Move Time and Channel Closing Transmission Time at 5260 MHz

Note: T1 denotes the start of Channel Move Time upon the end of the last Radar burst. T2 denotes the end of the Channel Move Time. $CMT = T2 - T1 = 8.26s$

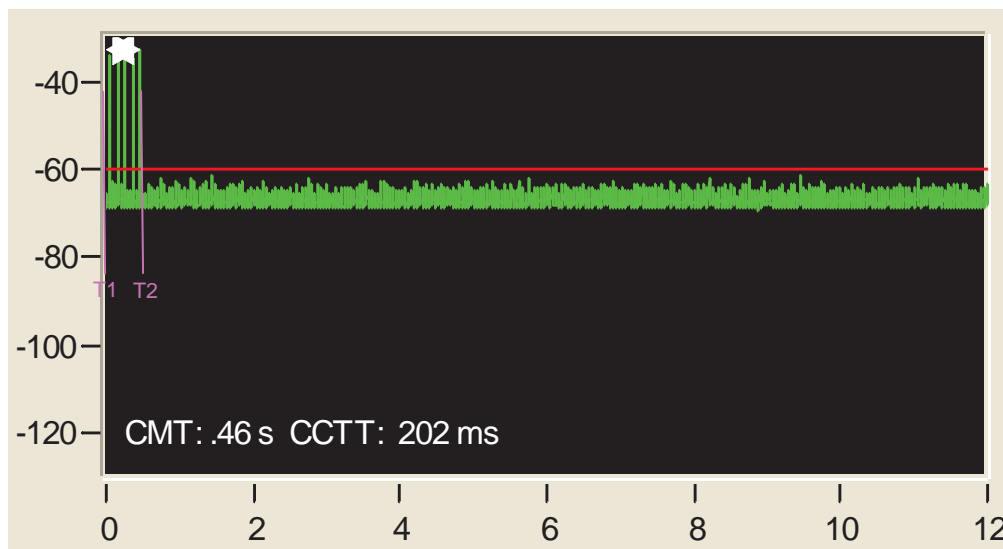

Figure 644: Channel Move Time and Channel Closing Transmission Time at 5300 MHz

Note: T1 denotes the start of Channel Move Time upon the end of the last Radar burst. T2 denotes the end of the Channel Move Time. $CMT = T2 - T1 = 0.46s$

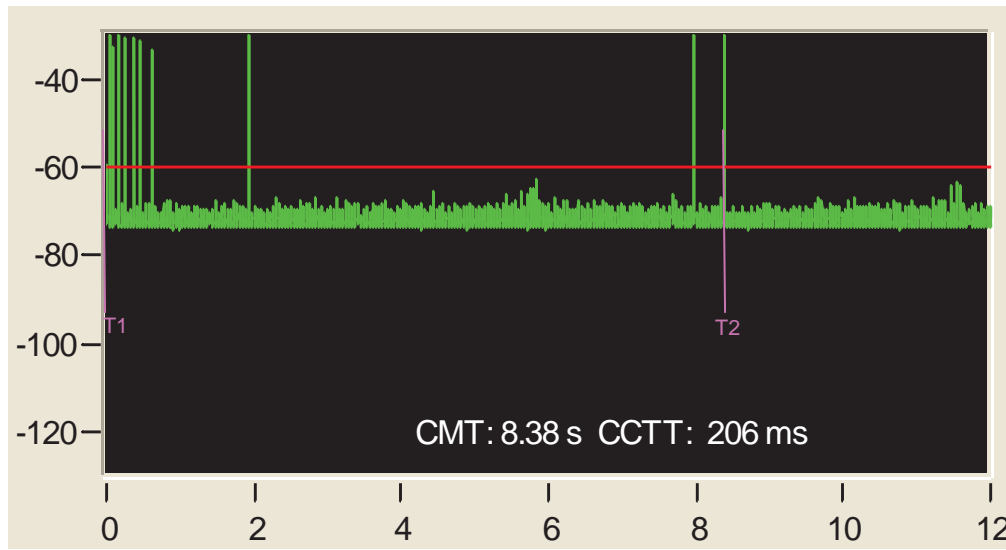

Figure 645: Channel Move Time and Channel Closing Transmission Time at 5500 MHz

Note: T1 denotes the start of Channel Move Time upon the end of the last Radar burst. T2 denotes the end of the Channel Move Time. $CMT = T2 - T1 = 8.38s$

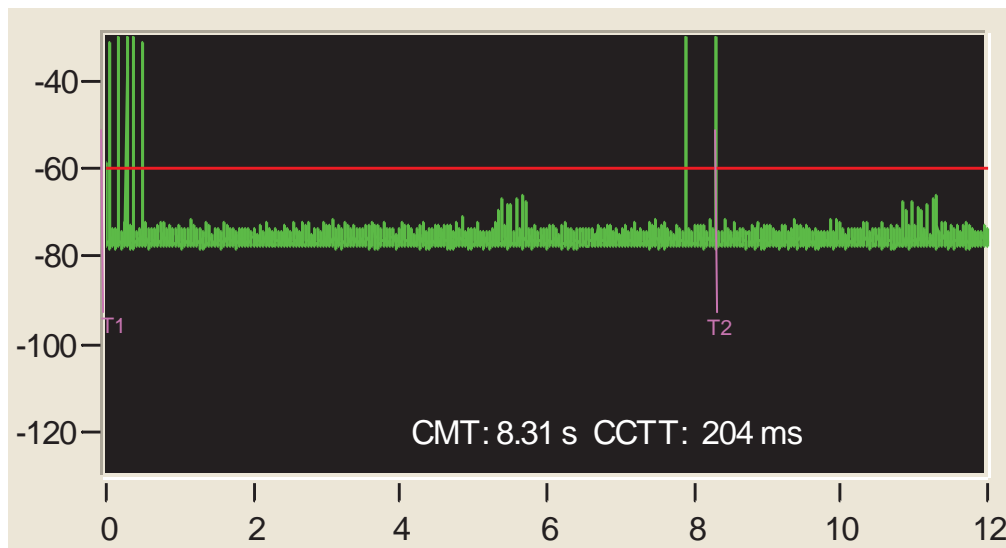

Figure 646: Channel Move Time and Channel Closing Transmission Time at 5540 MHz

Note: T1 denotes the start of Channel Move Time upon the end of the last Radar burst. T2 denotes the end of the Channel Move Time. $CMT = T2 - T1 = 8.31s$

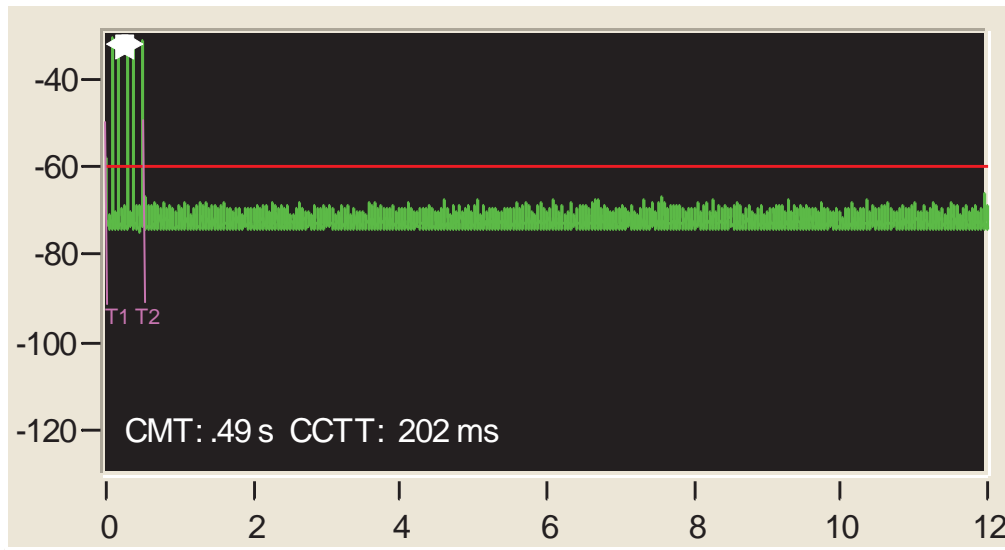

Figure 647: Channel Move Time and Channel Closing Transmission Time at 5560 MHz

Note: T1 denotes the start of Channel Move Time upon the end of the last Radar burst. T2 denotes the end of the Channel Move Time. $CMT = T2 - T1 = 0.49s$

5.5.2 Bandwidth of 40 MHz

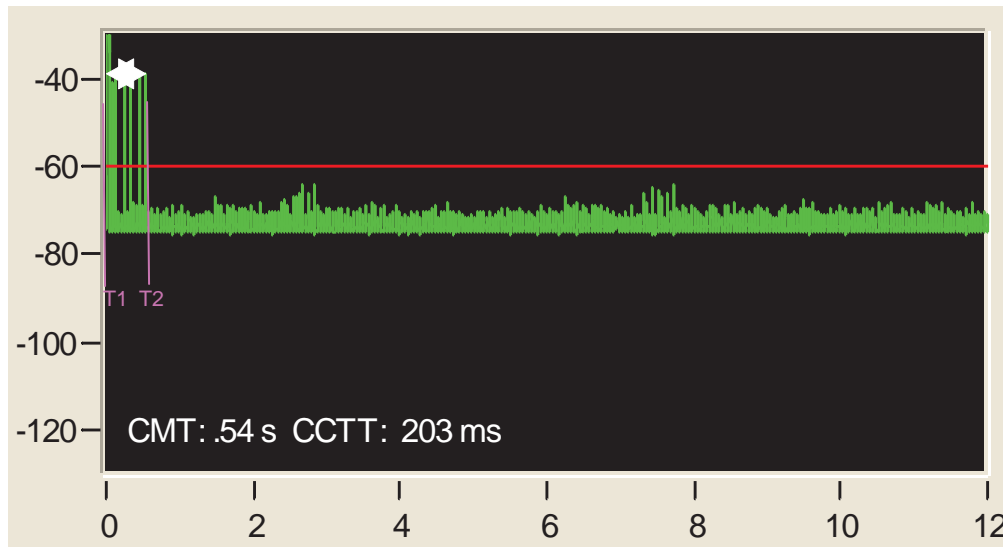

Figure 648: Channel Move Time and Channel Closing Transmission Time at 5310 MHz

Note: T1 denotes the start of Channel Move Time upon the end of the last Radar burst. T2 denotes the end of the Channel Move Time. $CMT = T2 - T1 = 0.54s$

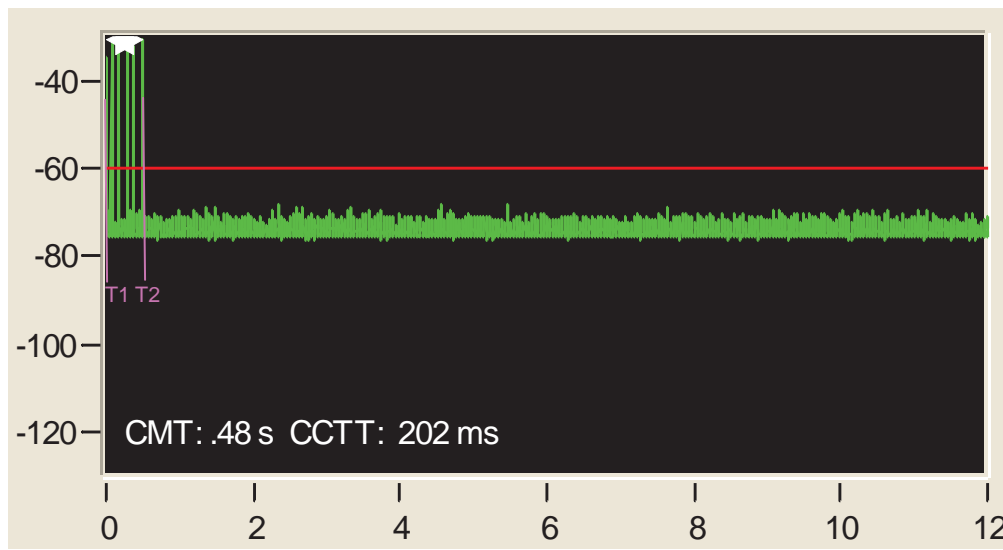

Figure 649: Channel Move Time and Channel Closing Transmission Time at 5320 MHz

Note: T1 denotes the start of Channel Move Time upon the end of the last Radar burst. T2 denotes the end of the Channel Move Time. $CMT = T2 - T1 = 0.48s$

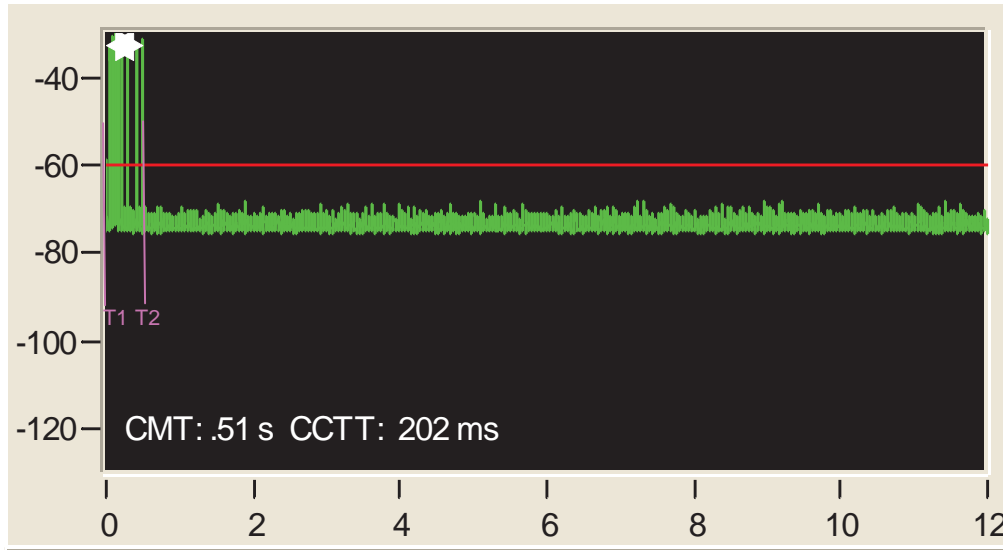

Figure 650: Channel Move Time and Channel Closing Transmission Time at 5680 MHz

Note: T1 denotes the start of Channel Move Time upon the end of the last Radar burst. T2 denotes the end of the Channel Move Time. $CMT = T2 - T1 = 0.51s$

6 Test Equipment Use List

6.1 Equipment List

Equipment	Manufacturer	Model #	Serial/Inst #	Last Cal dd/mm/yy	Next Cal dd/mm/yy
Bilog Antenna	Sunol Science	JB3	A102606	2/18/2010	2/18/2012
Horn Antenna	Sunol Scienece	DRH-118	A040806	9/29/2010	9/29/2012
Antenna (18-26GHz)	CMT	RA42-K-F-4B-C	020131-004	10/15/2010	10/15/2011
Antenna (26-40 GHz)	CMT	RA28-K-F-4B-C	011469R-003	10/15/2010	10/15/2011
EMI Receiver	Hewlett Packard	8546A	3807A00445	2/5/2011	2/5/2012
Preselector	Hewlett Packard	85460A	3704A00407	2/5/2011	2/5/2012
Amplifier	Hewlett Packard	8447D	2944A07996	1/17/2011	1/17/2012
Spectrum Analyzer	Rhode&Schwarz	ESIB	832427/002	1/18/2011	1/18/2012
Amplifier	Rhode&Schwarz	TS-PR18	3545.7008.03	9/29/2010	9/29/2012
Amplifier	Rhode&Schwarz	TS-PR26	100011	10/15/2010	10/15/2011
Amplifier	Rhode&Schwarz	TS-PR40	100012	10/15/2010	10/15/2011
Signal Generator	Anritsu	MG3694A	42803	1/26/2011	1/26/2012
Notch Filter	Micro-Tronics	BRM50702	37	1/19/2011	1/19/2012
Notch Filter	Micro-Tronics	BRC50703	11	1/19/2011	1/19/2012
Notch Filter	Micro-Tronics	BRC50704	8	1/19/2011	1/19/2012
Notch Filter	Micro-Tronics	BRC50705	9	1/19/2011	1/19/2012
High Pass Filter (3.5 GHz)	Hewlett Packard	84300-80038	820004	1/19/2011	1/19/2012
High Pass Filter (8.5 GHz)	Micro-Tronics	HPM50107	4	1/19/2011	1/19/2012
Power Supplier	Kikosui	PCR8000W	CM000912	1/19/2011	1/19/2012
Digital Multimeter	Fluke	177	92780314	1/18/2011	1/18/2012
Power Meter	Agilent	E4418B	MY45103902	1/18/2011	1/18/2012
Power Sensor	Hewlett Packard	8482A	55-5131	10/27/2010	10/27/2011
EMI Receiver	Hewlett Packard	8546A	3942A00514	11/22/2010	11/22/2011
Preselector	Hewlett Packard	85460A	3704A00485	11/22/2010	11/22/2011
LISN	Solar Electronics	Type 9348-50-R-24-BNC	68509	1/17/2011	1/17/2012
Thermometer	Fluke	52II	96480034	9/17/2010	9/17/2011
Signal Generator	Anritsu	MG3694A	42803	1/26/2011	1/26/2012
Thermo Chamber	Associated Environmental	SK-3102	5999	VBU	VBU
Spectrum Analyzer	Rhode&Schwarz	FSL6	100169	10/13/2010	10/13/2011
Spectrum Analyzer	Agilent	E4404B	MY41440636	8/19/2010	8/19/2011
Vector Signal Generator	Rhode&Schwarz	SMU 200A	1141.2005.02	03/05/2011	05/05/2011
Amplifier	Hewlett Packard	8449B	30008A01014	02/17/2011	05/17/2011

Calibration of equipment past due for re-calibration will be performed expeditiously. If any equipment is found to be out of tolerance at that time, affected customers will be notified accordingly.

7 EMC Test Plan

7.1 Introduction

This section provides a description of the Equipment Under Test (EUT), configurations, operating conditions, and performance acceptance criteria. It is an overview of information provided by the manufacturer so that the test laboratory may perform the requested testing.

7.2 Customer

Table 18: Customer Information

Company Name	Fluke Networks
Address	6920 Seaway Blvd
City, State, Zip	Everett, WA 98203
Country	USA
Phone	(719) 330-7471
Fax	(719) 330-7471

Table 19: Technical Contact Information

Name	Bradley Harper
E-mail	brad.harper@flukenetworks.com
Phone	(719) 330-7471
Fax	(719) 330-7471

7.3 Equipment Under Test (EUT)

Table 20: EUT Specifications

EUT Specification	
OptiView XG Dimensions	12.4" x 9.5" x 2.0"
AC Adapter (XP Power M/N: VEH90PS19)	Input Voltage: 100-240Vac 50-60Hz Input Current: 1200mA Output Voltage: 19VDC Output Current: 4.74A
Environment	Indoor and Outdoor
Operating Temperature Range:	0 to 50 degrees C
Multiple Feeds:	<input type="checkbox"/> Yes and how many <input checked="" type="checkbox"/> No
Hardware Version	Rev. 9
Part Number	3799739
RF Software Version	ART2.13
Radio Module 2 802.11-radio modules	
Operating Mode	802.11a, b, g, HT20, and HT40
Transmitter Frequency Band	2.412 GHz to 2.462 GHz 5.15 GHz to 5.25 GHz (Indoor Use) 5.25 GHz to 5.35 GHz 5.47 GHz to 5.725 GHz 5.725 GHz to 5.85 GHz
Max. Rated Power Output	See Channel Planning Table.
Power Setting @ Operating Channel	See Channel Planning Table.
Antenna Type	PCB Mounted Antenna (3 per module) External antenna for receive only. (5 dBi Dipole or 7 dBi Omni Antenna)
Modulation Type	<input type="checkbox"/> AM <input type="checkbox"/> FM <input checked="" type="checkbox"/> DSSS <input checked="" type="checkbox"/> OFDM <input type="checkbox"/> Other describe:

Date Rate	802.11b: 1, 2, 5.5, 11 Mbps at 1 Spatial Stream 802.11g: 6, 9, 12, 18, 24, 36, 48, 54 Mbps at 1 Spatial Stream 802.11a: 6, 9, 12, 18, 24, 36, 48, 54 Mbps at 1 Spatial Stream 802.11n HT20: 1 Spatial Stream: 6.5, 13, 19.5, 26, 39, 52, 58.5, 65 Mbps 2 Spatial Streams: 13, 26, 39, 58, 78, 104, 117, 130 Mbps 3 Spatial Streams: 19.5, 39, 58.5, 78, 117, 156, 175.5, 195 Mbps 802.11n HT40: 1 Spatial Stream: 13.5, 27, 40.5, 54, 81, 108, 121.5, 135 Mbps 2 Spatial Streams: 27, 54, 81, 108, 162, 216, 243, 270 Mbps 3 Spatial Streams: 40.5, 81, 121.5, 162, 243, 324, 364.5, 405 Mbps
TX/RX Chain (s)	MIMO (3x3)
Directional Gain Type	<input checked="" type="checkbox"/> Uncorrelated <input checked="" type="checkbox"/> No Beam-Forming <input type="checkbox"/> Other describe:
Type of Equipment	<input type="checkbox"/> Table Top <input type="checkbox"/> Wall-mount <input type="checkbox"/> Floor standing cabinet <input checked="" type="checkbox"/> Other <i>describe OptiView XG is portable device with 2 plug-in radio cards.</i>
Note: The right radio was selected for all RF evaluations due to its additional feature of external antenna selection for receiving.	

Table 21: EUT Channel Power Specifications

No.	Frequency (MHz)	Target Power Value				
		802.11b	802.11g	802.11a	802.11n HT20	802.11n HT40
1	2412	12	12		12.5	8
2	2417	12	12		12.5	8
3	2422	12	12		12.5	8
4	2427	12	12		12.5	8
5	2432	12	12		12.5	8
6	2437	12	12		12.5	8
7	2442	12	12		12.5	8
8	2447	12	12		12.5	
9	2452	12	12		12.5	
10	2457	12	12		12.5	
11	2462	12	12		12.5	
36	5180			11	11.5	11
40	5200			11	11.5	
44	5220			11	11.5	11
48	5240			11	11.5	
52	5260			16	14.5	13.5
56	5280			16	14.5	
60	5300			16	14.5	11
64	5320			14	14.5	
100	5500			14	10	10
104	5520			14	10	
108	5540			14	10	10
112	5560			14	10	
116	5580			14	14.5	12.5
120	5600			14	14.5	
124	5620			14	14.5	12.5
128	5640			14	14.5	
132	5660			13	14.5	12.5
136	5680			13	14.5	
140	5700			13	14.5	
149	5745			13	14.5	12.5
153	5765			13	14.5	
157	5785			13	14.5	12.5
159	5795			13	14.5	
161	5805			13	14.5	
165	5825			13	14.5	

Note: 1. The center operating frequency is shifted upward by 10 MHz for HT40.
 2. The adjusted power target values are updated at the evaluated frequencies.

Table 22: Interface Specifications

Interface Type	Cabled with what type of cable?	Is the cable shielded?	Maximum potential length of the cable?	Metallic (M), Coax (C), Fiber (F), or Not Applicable?
USB x2	Unterminated	<input type="checkbox"/> No	<input type="checkbox"/> Metric: 1.8m	<input checked="" type="checkbox"/> M
MGM	Unterminated	<input type="checkbox"/> No	<input type="checkbox"/> Metric: 1.8m	<input checked="" type="checkbox"/> M
RJ45 (x2)	Unterminated	<input type="checkbox"/> No	<input type="checkbox"/> Metric: 10 m	<input checked="" type="checkbox"/> M
SFP (x2)	Unterminated	<input type="checkbox"/> No	<input type="checkbox"/> Metric: 3 m	<input checked="" type="checkbox"/> Fiber
Video	Unterminated	<input type="checkbox"/> No	<input type="checkbox"/> Metric: 1.8m	<input checked="" type="checkbox"/> M
eSATA	Unterminated	<input type="checkbox"/> No	<input type="checkbox"/> Metric: 1 m	<input checked="" type="checkbox"/> M

Table 23: Supported Equipment

Equipment	Manufacturer	Model	Serial	Used for
Access Point	Cisco	Air-RM1252G-A-k9	FTX123493DS	DFS Testing
Note: None.				

Table 24: Description of Sample used for Testing

Device	Serial	RF Connection	CFR47 Part 15.247
OptiView XG	Prototype #1	Integrated Antenna	TX Emission, RX Emission, AC Conducted Emission
	Prototype #2	Direct via SMA	Peak Transmit Power, Peak Power Spectral Density, Peak Excursion Ratio Occupied Bandwidth Frequency Stability Dynamic Frequency Selection

Table 25: Description of Test Configuration used for Radiated Measurement.

Device	Antenna	Mode	Setup Photo (X-Axis)	Setup Photo (Y-Axis)	Setup Photo (Z-Axis)
OptiView XG	Integrated	* Transmit * Receive	LCD faced up.	LCD faced sideways	Holding Side faced upward.

Note: Pre-scans were performed in 3 orthogonal axis, and Y-axis was worst.

Table 26: Final Test Mode for All 3 Bands

Test	802.11a	802.11n HT20	802.11n HT40
Occupied Bandwidth FCC Part 15.407(a)	Band 1: 5180, 5220, 5240 MHz Band 2: 5260, 5300, 5320 MHz Band 3: 5500, 5600, 5700 MHz @ 6Mbps	Band 1: 5180, 5220, 5240 MHz Band 2: 5260, 5300, 5320 MHz Band 3: 5500, 5600, 5700 MHz 1 Stream – 6.5Mbps	Band 1: 5190, 5230 MHz Band 2: 5270, 5310 MHz Band 3: 5510, 5590, 5670 MHz 1 Stream – 13.5Mbps
Output Power FCC Part 15.407(a)(1-2)	Band 1: 5180, 5220, 5240 MHz Band 2: 5260, 5300, 5320 MHz Band 3: 5500, 5600, 5700 MHz @ 6Mbps	Band 1: 5180, 5220, 5240 MHz Band 2: 5260, 5300, 5320 MHz Band 3: 5500, 5600, 5700 MHz 1 Stream – 6.5Mbps 2 Streams – 13Mbps 3 Streams – 19.5Mbps	Band 1: 5190, 5230 MHz Band 2: 5270, 5310 MHz Band 3: 5510, 5590, 5670 MHz 1 Stream – 13.5Mbps 2 Streams – 27Mbps 3 Streams – 40.5Mbps
Peak Excursion Ratio FCC Part 15.407(a)(6)	Band 1: 5180, 5220, 5240 MHz Band 2: 5260, 5300, 5320 MHz Band 3: 5500, 5600, 5700 MHz @ 6Mbps	Band 1: 5180, 5220, 5240 MHz Band 2: 5260, 5300, 5320 MHz Band 3: 5500, 5600, 5700 MHz 1 Stream – 6.5Mbps 2 Streams – 13Mbps 3 Streams – 19.5Mbps	Band 1: 5190, 5230 MHz Band 2: 5270, 5310 MHz Band 3: 5510, 5590, 5670 MHz 1 Stream – 13.5Mbps 2 Streams – 27Mbps 3 Streams – 40.5Mbps
Peak Power Spectral Density FCC Part 15.407(a)	Band 1: 5180, 5220, 5240 MHz Band 2: 5260, 5300, 5320 MHz Band 3: 5500, 5600, 5700 MHz @ 6Mbps	Band 1: 5180, 5220, 5240 MHz Band 2: 5260, 5300, 5320 MHz Band 3: 5500, 5600, 5700 MHz 1 Stream – 6.5Mbps 2 Streams – 13Mbps 3 Streams – 19.5Mbps	Band 1: 5190, 5230 MHz Band 2: 5270, 5310 MHz Band 3: 5510, 5590, 5670 MHz 1 Stream – 13.5Mbps 2 Streams – 27Mbps 3 Streams – 40.5Mbps
Band-Edge (Radiated) FCC Part 15.205, 15.209, 15.407(b)	Band 1: 5180, 5220, 5240 MHz Band 2: 5260, 5300, 5320 MHz Band 3: 5500, 5600, 5700 MHz @ 6Mbps	Band 1: 5180, 5220, 5240 MHz Band 2: 5260, 5300, 5320 MHz Band 3: 5500, 5600, 5700 MHz 3 Stream – 19.5Mbps	Band 1: 5190, 5230 MHz Band 2: 5270, 5310 MHz Band 3: 5510, 5590, 5670 MHz 1 Stream – 13.5Mbps
Transmitted Spurious Emission (30 MHz – 1GHz) FCC Part 15.205, 15.209, 15.407(b)	Worst Case: 5300 MHz @ 6Mbps (Y-Axis)		
Transmitted Spurious Emission (Above 1GHz) FCC Part 15.205, 15.209, 15.407(b)	Band 1: 5180, 5220, 5240 MHz Band 2: 5260, 5300, 5320 MHz Band 3: 5500, 5600, 5700 MHz @ 6Mbps (Y-Axis)	Band 1: 5180, 5220, 5240 MHz Band 2: 5260, 5300, 5320 MHz Band 3: 5500, 5600, 5700 MHz 1 Stream – 6.5Mbps (Y-Axis)	Band 1: 5190, 5230 MHz Band 2: 5270, 5310 MHz Band 3: 5510, 5590, 5670 MHz 3 Stream – 40.5Mbps (Y-Axis)
Conducted Spurious Emission (antenna port). FCC Part 15.407 (b)	According to CFR47 15.407 (b) EIPR shall not exceed -27 dBm/MHz. This is equivalent to the field strength of 68.2dBuV/m at 3 meter distance. The EUT is satisfied the requirement by meeting the limit under CFR47 Part 15.209.		
Received Spurious Emission (at 20 MHz & 40 MHz Bandwidth) FCC Part 15.109		Band 1: 5220 MHz (Y-Axis) Band 2: 5300 MHz (Y-Axis) Band 3: 5600 MHz (Y-Axis)	Band 1: 5230 MHz (Y-Axis) Band 2: 5310 MHz (Y-Axis) Band 3: 5590 MHz (Y-Axis)

AC Conducted Emission FCC Part 15.207		5300 MHz at 1 Data Stream: 6.5Mbps	
Frequency Stability FCC Part 15.407 (g)	Continuous wave at 5320 MHz		
Voltage Variation FCC Part 15.31 (e)	Continuous wave at 5180, 5220, 5240, 5260, 5300, 5320, 5500, 5600, 5700 MHz.		
Dynamic Frequency Selection FCC Part 15.407 (h)	OptiView XG configured in the normal operating mode. It connected Cisco AP and streamed the TestFile.mpg file from the supporting laptop.		
<p>Note:</p> <ol style="list-style-type: none"> 1. Band 1: 5150 MHz – 5250 MHz, Band 2: 5250 MHz – 5350 MHz, Band 3: 5470 MHz – 5725MHz. 2. All radiated emission performed on Y-Axis. 3. At single data stream, all 3 transmitted chains were verified. Since Chain 1 output was highest, all final testing performed with Chain 1 active. 4. All tests were pre-scanned for worst case before final testing. 5. 7 dBi Omni directional antenna was attached for all radiated emission testing; pre-scan was worst with omni antenna vs. monopole antenna. 6. AC Conducted Emissions were verified for all modes with battery charging and without battery. Worst mode was selected for final test. 			

7.4 Test Specifications

Testing requirements

Table 27: Test Specifications

Emissions and Immunity	
Standard	Requirement
CFR 47 Part 15.407: 2009	All
RSS 210 Issue 8, 2010	All



OPTIVIEW XG models

TO WHOM IT MAY CONCERN:

OptiViewXG is a family name for all the product hardware described below, each model is the same from a WiFi radio standpoint and the only difference is SW options that do not affect the RF hardware.

Model Number	Item Number
MAINFRAMES AND BUNDLES	
OPVXG, NETWORK ANALYSIS TABLET (GIG)	3365336
OPVXG-10G, NETWORK ANALYSIS TABLET (10 GIG)	3949542
OPVXGPRO, Network Analysis Tablet (GIG) with WiFi Analyzer and Spectrum XT	3949602
OPVXG-EXPT, Network Analysis Tablet (10 GIG) with WiFi Analyzer and Spectrum XT	3949616
OPVXG-LAN, OPVXG-LAN, OPTIVIEW XG - LAN, NETWORK ANALYSIS TABLET	3949556
OPVXG-LAN-10G, OPTIVIEW XG NETWORK ANALYSIS TABLET (10 GIG)	4020634
OPVXG-WLAN, OPTIVIEW XG WLAN, NETWORK ANALYSIS TABLET	3949539

Sincerely,

Date: 20 April 2011

By:

Signature

Brad Harper

Printed Name

Title: Project Manager Tel.No: 719-272-8675