

Date: 10.MAR.2011 13:23:13

Figure 275: Peak Power Spectral Density for Operating Channel 2437MHz, Chain 2 – HT40 40.5 Mbps

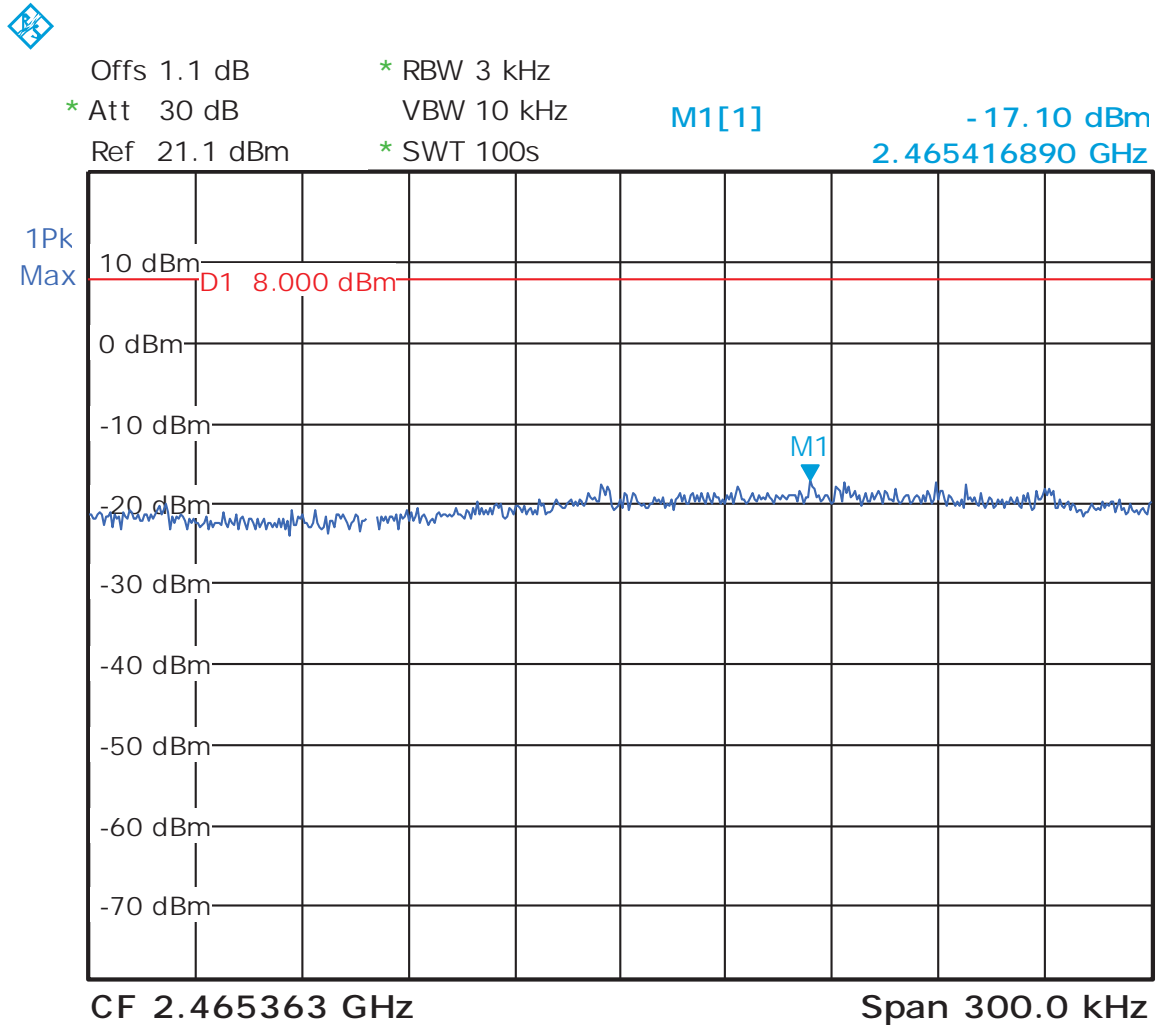

Date: 10.MAR.2011 13:27:42

Figure 276: Peak Power Spectral Density for Operating Channel 2452MHz, Chain 2 – HT40 40.5 Mbps

4.5 Transmitter Spurious Emissions

Transmitter spurious emissions are emissions outside the frequency range of the equipment when the equipment is in transmit mode; per requirement of CFR47 15.205, 15.209, 15.247(d), RSS 210 Sect. A.8.5

4.5.1 Test Methodology

4.5.1.1 Preliminary Test

A test program that controls instrumentation and data logging was used to automate the preliminary RF emission test procedure. The frequency range of interest was divided into sub-ranges to yield a frequency resolution of approximately 120 kHz and provide a reading at each frequency for no more than 12° of turntable rotation. For each frequency sub-range the turntable was rotated 360° while peak emission data was recorded and plotted over the frequency range of interest in horizontal and vertical antenna polarization's.

Preliminary emission profile testing was performed inside the anechoic chamber. The EUT was placed on a 1.0m x 1.5m non-conductive table 80cm above the floor. The EUT was positioned as shown in the setup photographs. The receiving antenna was placed at a distance of 3m at a fixed height of 1m. Measurement equipment was located outside of the chamber. A video camera was placed inside the chamber to view the EUT.

4.5.1.2 Final Test

For each frequency measured, the peak emission was maximized by manipulating the receiving antenna from 1 to 4 meters above the ground plane and placing it at the position that produced the maximum signal strength reading. The turntable was then rotated through 360° while observing the peak signal and placing the EUT at the position that produced maximum radiation. The six highest emissions relative to the limit were measured unless such emissions were more than 20 dB below the limit. If less than six emissions are within 20 dB of the limit, than the noise level of the receiver is measured at frequencies where emissions are expected. Multiples of all oscillator and microprocessor frequencies were also checked.

Final testing was performed on an NSA compliant test site. The EUT was placed on a 1.0m x 1.5m non-conductive table 80cm above the ground plane. The placement of EUT and cables were the same as for preliminary testing and is shown in the setup photographs.

The final scans performed on the worst axis, Y-Axis, for three operating channels;

2412MHz, 2437MHz, and 2462MHz at 1Mbit/s for 802.11b mode,

2412MHz, 2437MHz, and 2462MHz at 6Mbit/s for 802.11g mode,

2412MHz, 2437MHz, and 2462MHz at 6.5Mbit/s for 802.11n HT20 mode, and

2422MHz, 2437MHz, and 2452MHz at 13.5Mbit/s for 802.11n HT40 mode.

4.5.1.3 Deviations

None.

4.5.2 Transmitter Spurious Emission Limit

The spurious emissions of the transmitter shall not exceed the values in CFR47 Part 15.205, 15.209: 2009 and RSS 210 A1.1.2 2010.

Frequency (MHz)	Field strength (microvolts/meter)	Measurement distance (meters)
0.009-0.490.....	2400/F (kHz)	300
0.490-1.705.....	24000/F (kHz)	30
1.705-30.0.....	30	30
30-88.....	100 **	3
88-216.....	150 **	3
216-960.....	200 **	3
Above 960.....	500	3

All harmonics and spurious emission which are outside of the restricted band shall be 20 dB below the in-band emission.

4.5.3 Test Results

The final measurement data was taken under the worst case operating modes, configurations, and/or cable positions. It also reflects the results including any modifications and/or special accessories listed in Sections 1.4 and Test Plan.

As originally tested, the EUT was found to be compliant to the requirements of the test standard(s).

Table 7: Transmit Spurious Emission at Band-Edge Requirements

Test Conditions: Radiated Measurement, Normal Temperature and Voltage only							
Antenna Type: Integrated				Power Setting: See test plan			
Max. Antenna Gain: + 1.1dBi				Signal State: Modulated at 99%			
Ambient Temp.: 22 °C				Relative Humidity: 34%			
Band-Edge Results							
Operating Channel	Mode	Polarity	Pk Plots	Peak Limit	Ave. Plots	Ave. Limit	Result
2412 MHz	802.11b 1Mbps	Horz.	277	74.00	278	54.00	Pass
2412 MHz	802.11b 1Mbps	Vert.	279	74.00	280	54.00	Pass
2437 MHz	802.11b 1Mbps	Horz.	281	74.00	282	54.00	Pass
2437 MHz	802.11b 1Mbps	Vert.	283	74.00	284	54.00	Pass
2462 MHz	802.11b 1Mbps	Horz.	285	74.00	286	54.00	Pass
2462 MHz	802.11b 1Mbps	Vert.	287	74.00	288	54.00	Pass
2412 MHz	802.11g 9Mbps	Horz.	289	74.00	290	54.00	Pass
2412 MHz	802.11g 9Mbps	Vert.	291	74.00	292	54.00	Pass
2437 MHz	802.11g 9Mbps	Horz.	293	74.00	294	54.00	Pass
2437 MHz	802.11g 9Mbps	Vert.	295	74.00	296	54.00	Pass
2462 MHz	802.11g 9Mbps	Horz.	297	74.00	298	54.00	Pass
2462 MHz	802.11g 9Mbps	Vert.	299	74.00	300	54.00	Pass
2412 MHz	802.11n (HT20) 1	Horz.	301	74.00	302	54.00	Pass
2412 MHz	802.11n (HT20) 1	Vert.	303	74.00	304	54.00	Pass
2437 MHz	802.11n (HT20) 1	Horz.	305	74.00	306	54.00	Pass
2437 MHz	802.11n (HT20) 1	Vert.	307	74.00	308	54.00	Pass
2462 MHz	802.11n (HT20) 1	Horz.	309	74.00	310	54.00	Pass
2462 MHz	802.11n (HT20) 1	Vert.	311	74.00	312	54.00	Pass
2412 MHz	802.11n (HT20) 0,1	Horz.	313	74.00	314	54.00	Pass

2412 MHz	802.11n (HT20) 0,1	Vert.	315	74.00	316	54.00	Pass
2437 MHz	802.11n (HT20) 0,1	Horz.	317	74.00	318	54.00	Pass
2437 MHz	802.11n (HT20) 0,1	Vert.	319	74.00	320	54.00	Pass
2462 MHz	802.11n (HT20) 0,1	Horz.	321	74.00	322	54.00	Pass
2462 MHz	802.11n (HT20) 0,1	Vert.	323	74.00	324	54.00	Pass
2412 MHz	802.11n (HT20) 0,1,2	Horz.	325	74.00	326	54.00	Pass
2412 MHz	802.11n (HT20) 0,1,2	Vert.	327	74.00	328	54.00	Pass
2437 MHz	802.11n (HT20) 0,1,2	Horz.	329	74.00	330	54.00	Pass
2437 MHz	802.11n (HT20) 0,1,2	Vert.	331	74.00	332	54.00	Pass
2462 MHz	802.11n (HT20) 0,1,2	Horz.	333	74.00	334	54.00	Pass
2462 MHz	802.11n (HT20) 0,1,2	Vert.	335	74.00	336	54.00	Pass
2422 MHz	802.11n (HT40) 1	Horz.	337	74.00	338	54.00	Pass
2422 MHz	802.11n (HT40) 1	Vert.	339	74.00	340	54.00	Pass
2437 MHz	802.11n (HT40) 1	Horz.	341	74.00	342	54.00	Pass
2437 MHz	802.11n (HT40) 1	Vert.	343	74.00	344	54.00	Pass
2452 MHz	802.11n (HT40) 1	Horz.	345	74.00	346	54.00	Pass
2452 MHz	802.11n (HT40) 1	Vert.	347	74.00	348	54.00	Pass
2422 MHz	802.11n (HT40) 0,1	Horz.	349	74.00	350	54.00	Pass
2422 MHz	802.11n (HT40) 0,1	Vert.	351	74.00	352	54.00	Pass
2437 MHz	802.11n (HT40) 0,1	Horz.	353	74.00	354	54.00	Pass
2437 MHz	802.11n (HT40) 0,1	Vert.	355	74.00	356	54.00	Pass
2452 MHz	802.11n (HT40) 0,1	Horz.	357	74.00	358	54.00	Pass
2452 MHz	802.11n (HT40) 0,1	Vert.	359	74.00	360	54.00	Pass
2422 MHz	802.11n (HT40) 0,1,2	Horz.	361	74.00	362	54.00	Pass
2422 MHz	802.11n (HT40) 0,1,2	Vert.	363	74.00	364	54.00	Pass
2437 MHz	802.11n (HT40) 0,1,2	Horz.	365	74.00	366	54.00	Pass

2437 MHz	802.11n (HT40) 0,1,2	Vert.	367	74.00	368	54.00	Pass
2452 MHz	802.11n (HT40) 0,1,2	Horz.	369	74.00	370	54.00	Pass
2452 MHz	802.11n (HT40) 0,1,2	Vert.	371	74.00	372	54.00	Pass

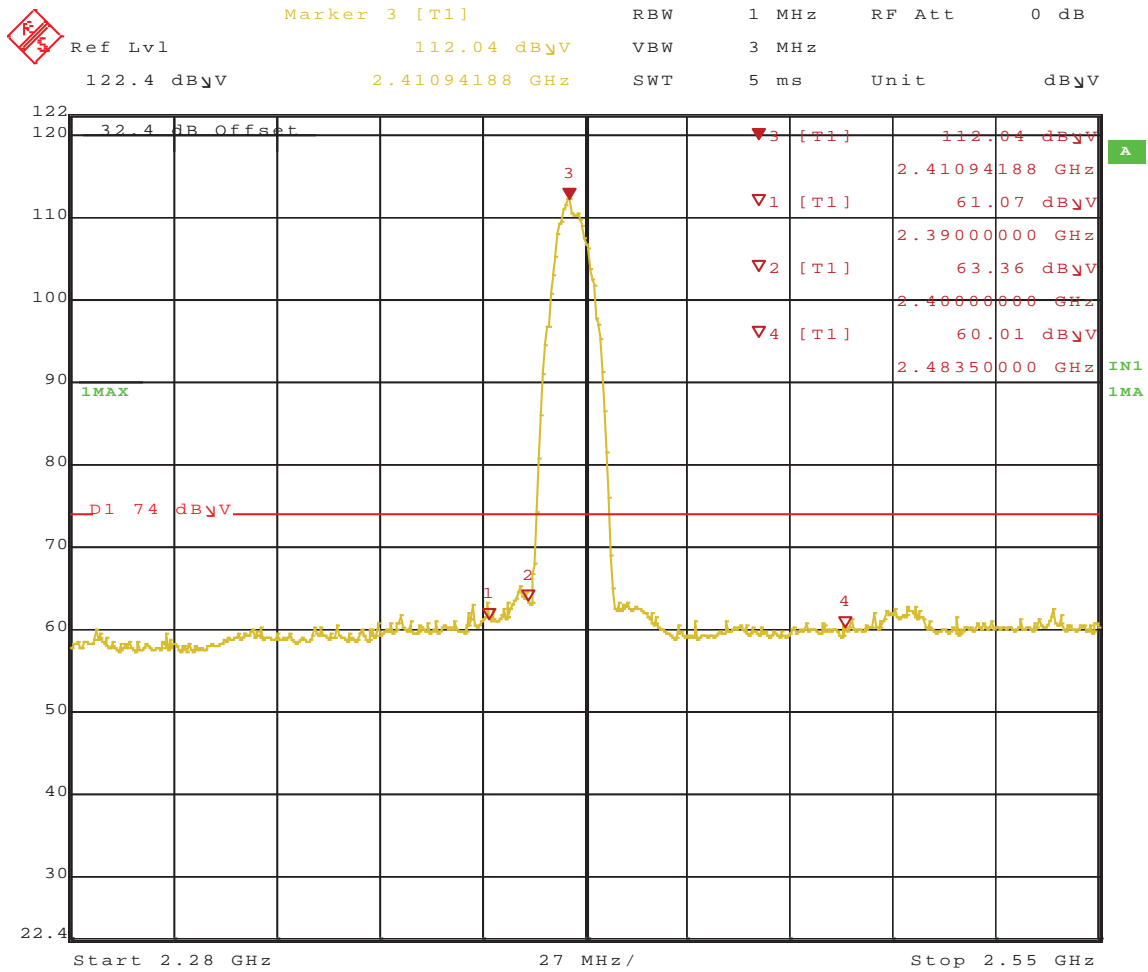

Date: 19.JAN.2011 09:23:19

Figure 277: Radiated Emission at the Edge for Channel 2412MHz at 1Mbps – Horizontal (Peak)

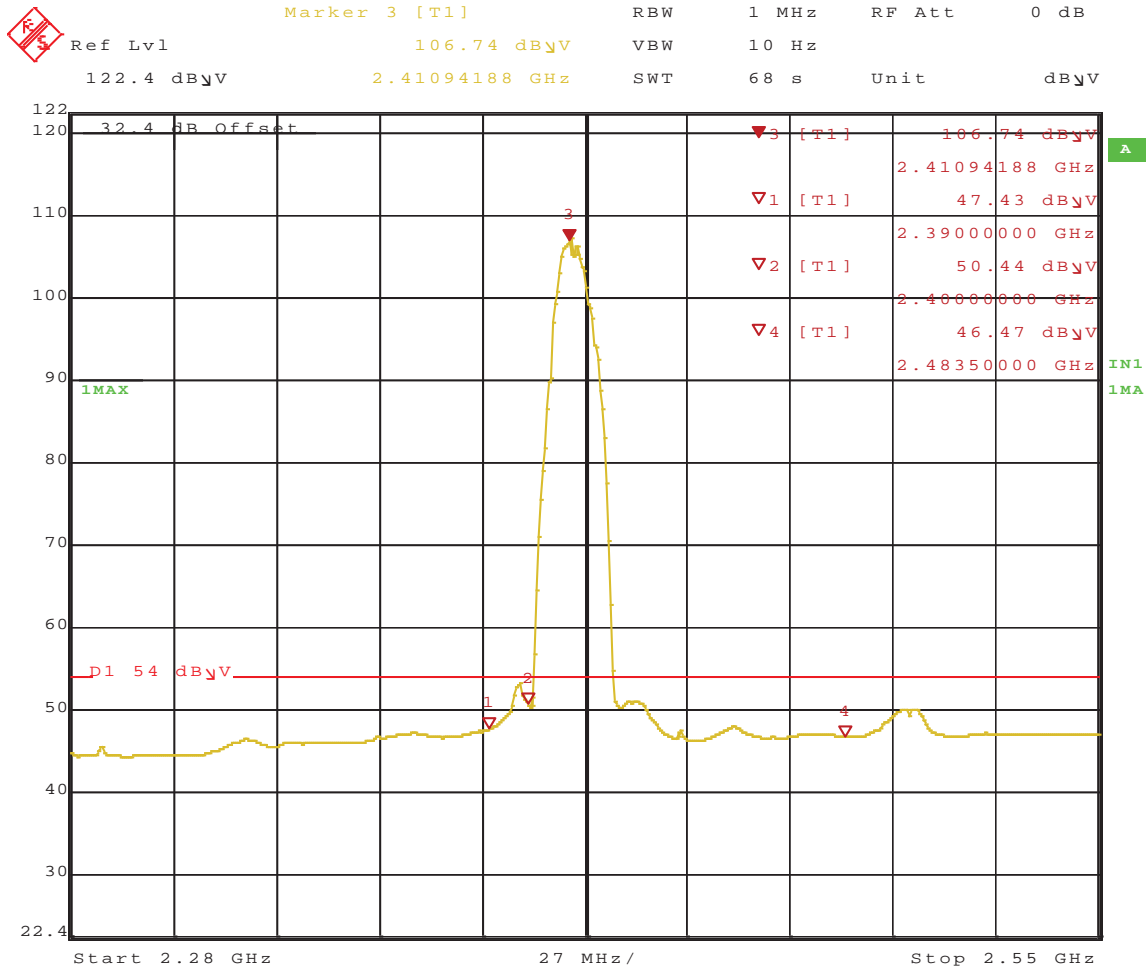

Date: 19.JAN.2011 09:25:13

Figure 278: Radiated Emission at the Edge for Channel 2412MHz at 1Mbps – Horizontal (Ave.)

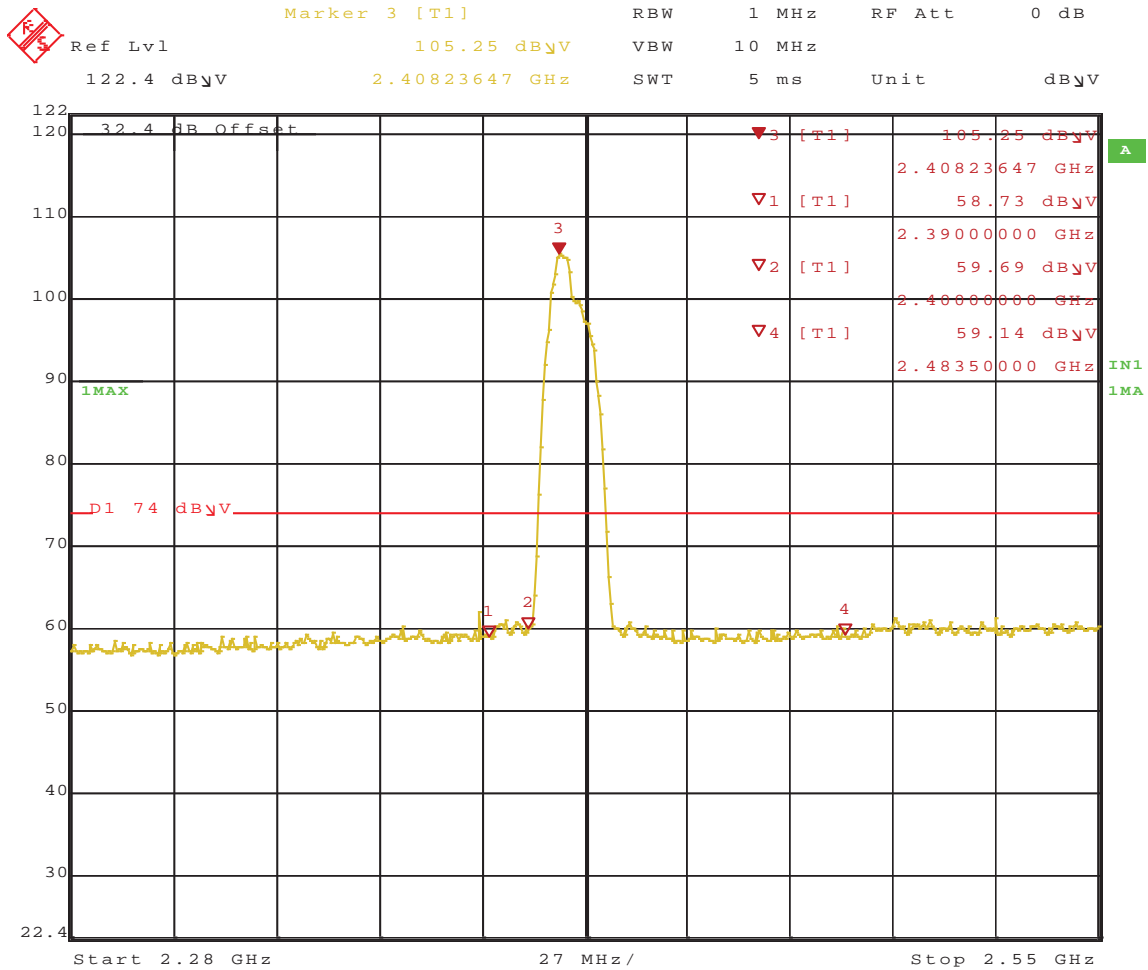

Date: 19.JAN.2011 09:29:04

Figure 279: Radiated Emission at the Edge for Channel 2412MHz at 1Mbps – Vertical (Peak)

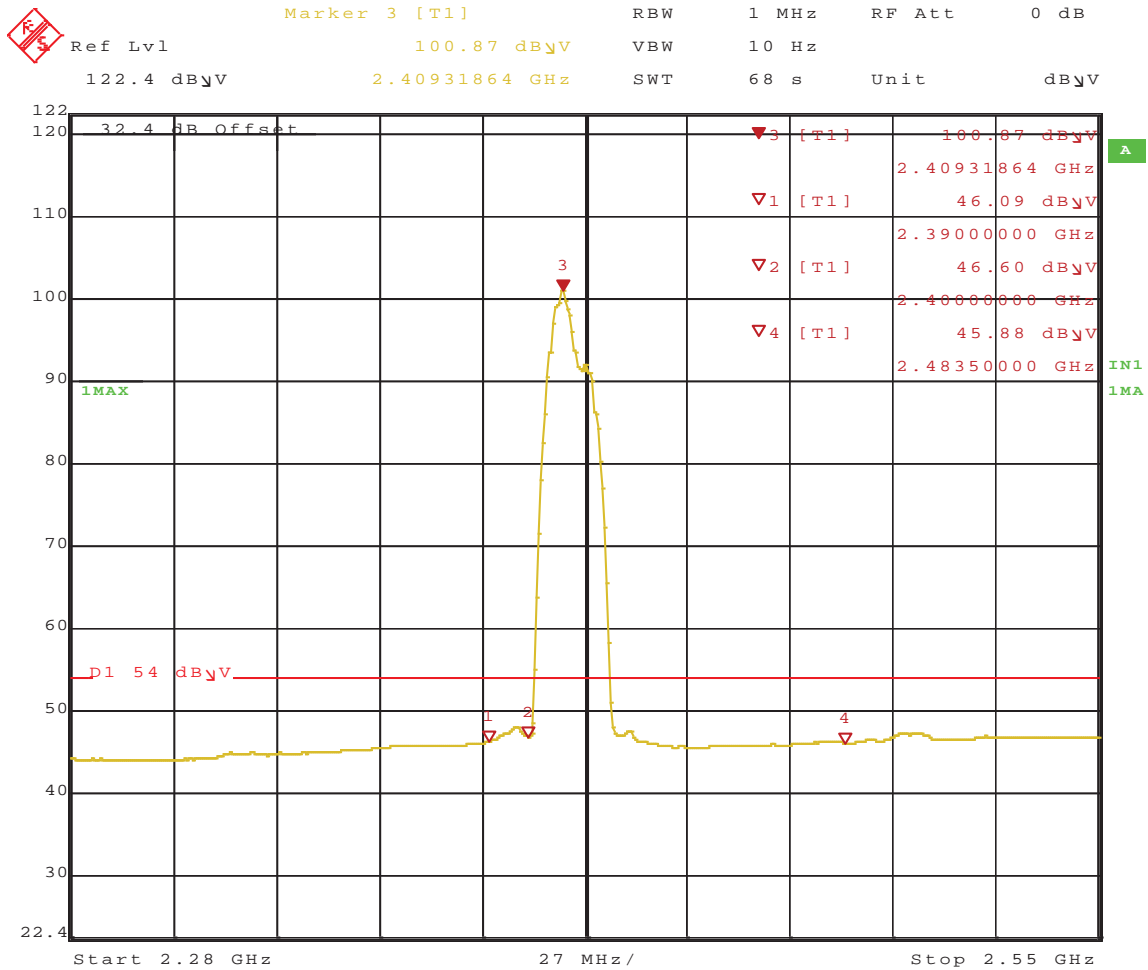

Date: 19.JAN.2011 09:30:39

Figure 280: Radiated Emission at the Edge for Channel 2412MHz at 1Mbps – Vertical (Ave.)

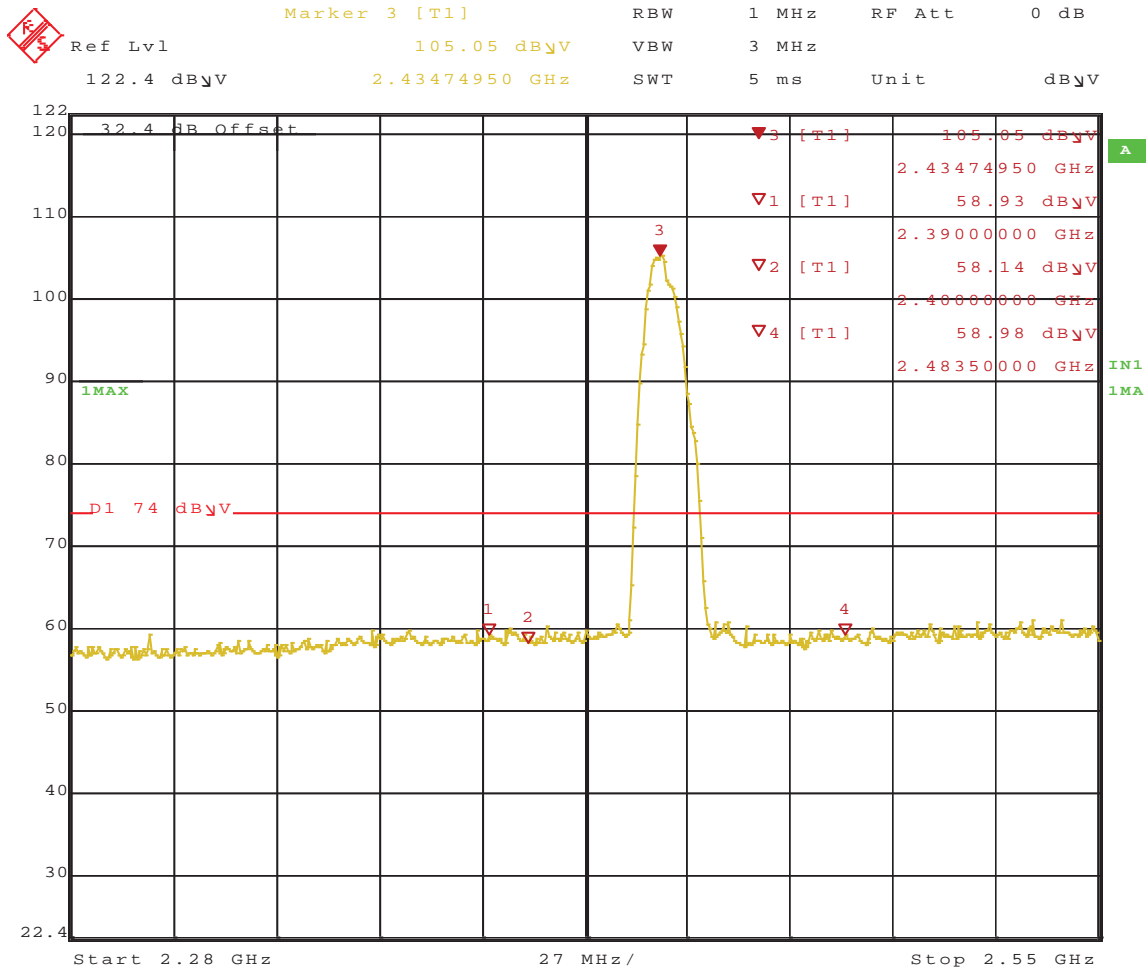

Date: 19.JAN.2011 09:34:42

Figure 281: Radiated Emission at the Edge for Channel 2437MHz at 1Mbps – Horizontal (Peak)

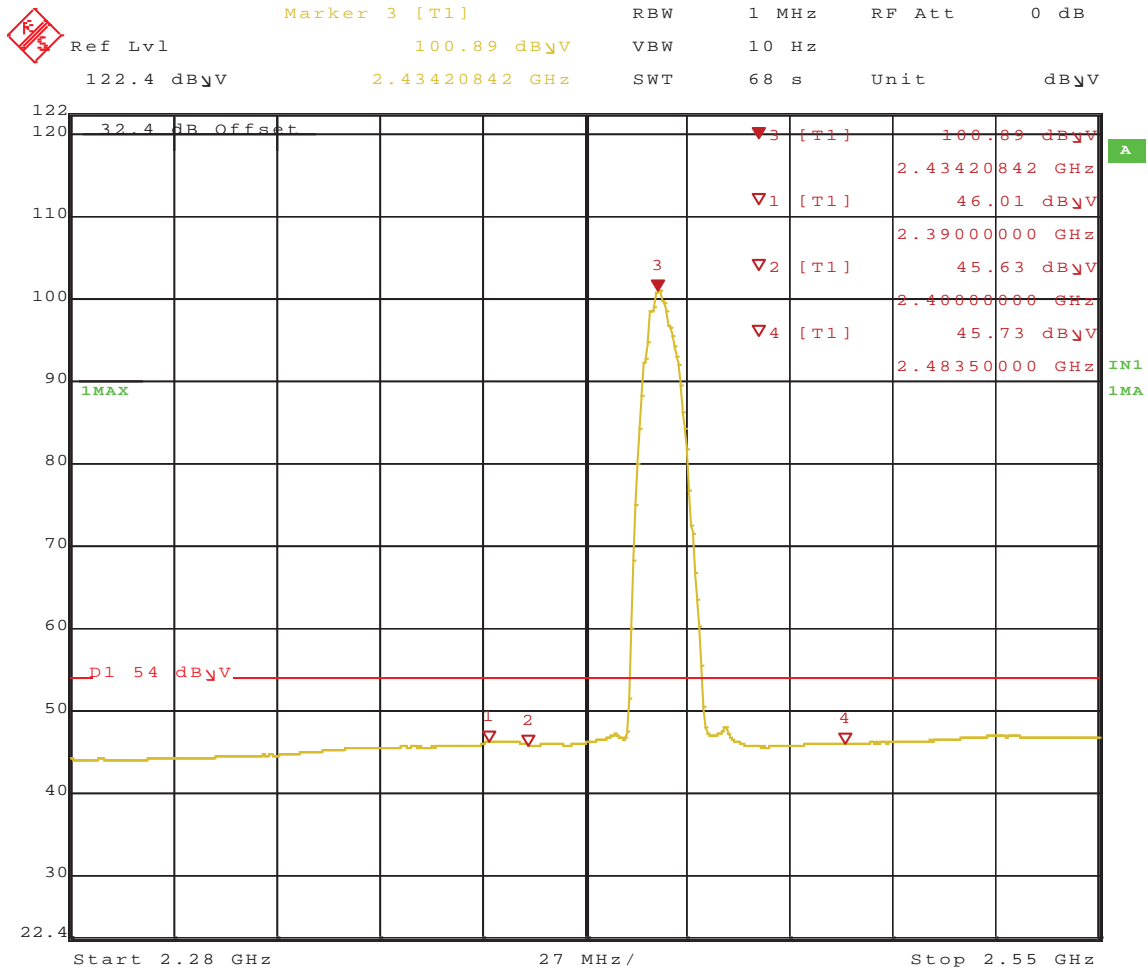

Date: 19.JAN.2011 09:36:22

Figure 282: Radiated Emission at the Edge for Channel 2437MHz at 1Mbps – Horizontal (Ave.)

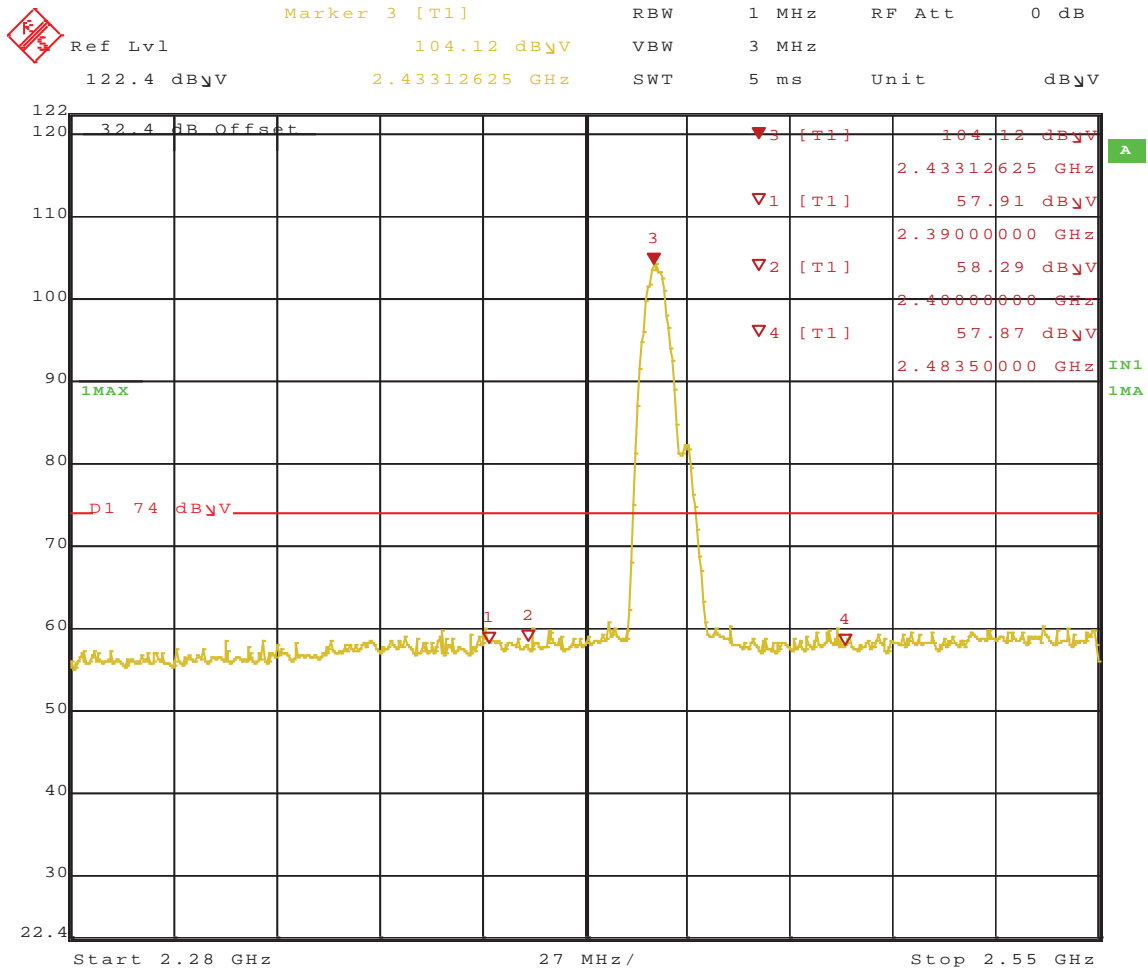

Date: 19.JAN.2011 09:39:03

Figure 283: Radiated Emission at the Edge for Channel 2437MHz at 1Mbps – Vertical (Peak)

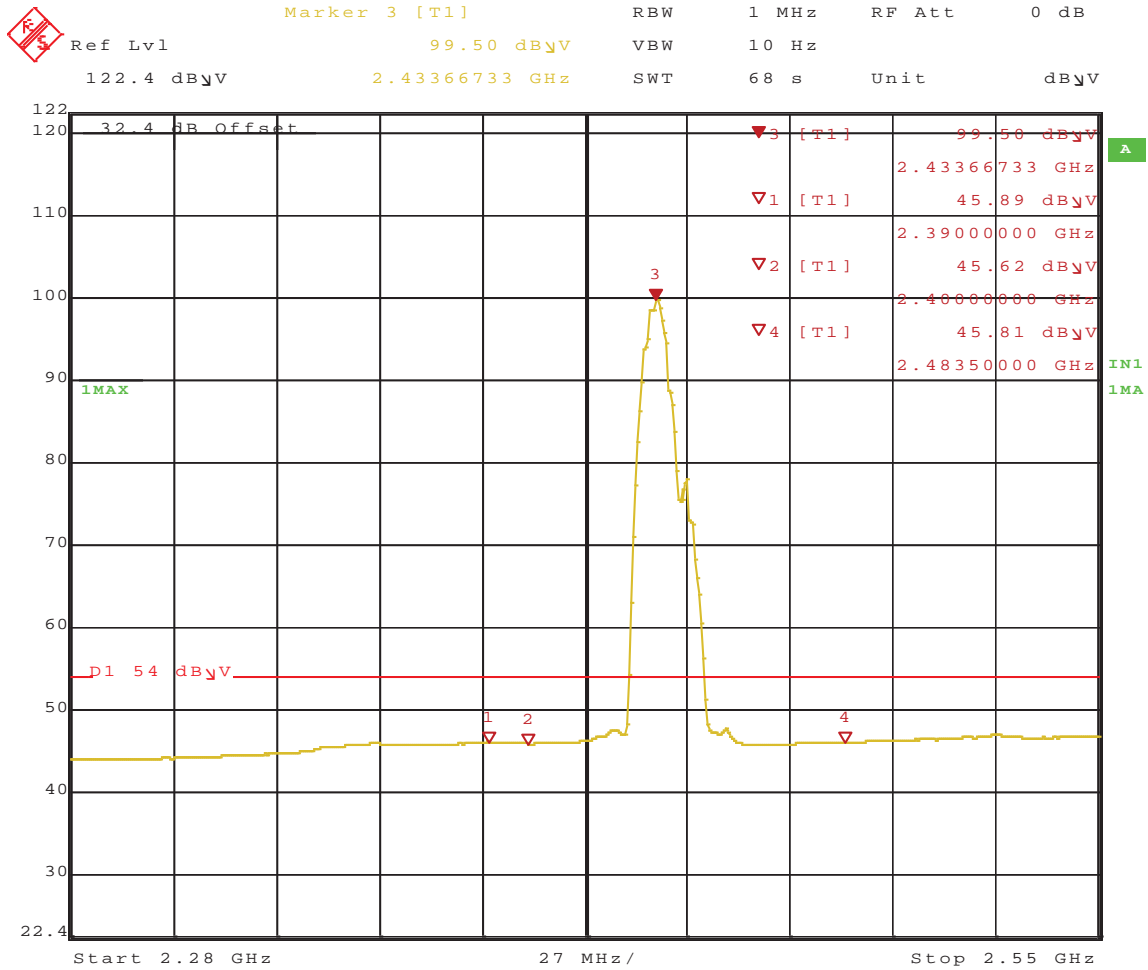

Date: 19.JAN.2011 09:41:04

Figure 284: Radiated Emission at the Edge for Channel 2437MHz at 1Mbps – Vertical (Ave.)

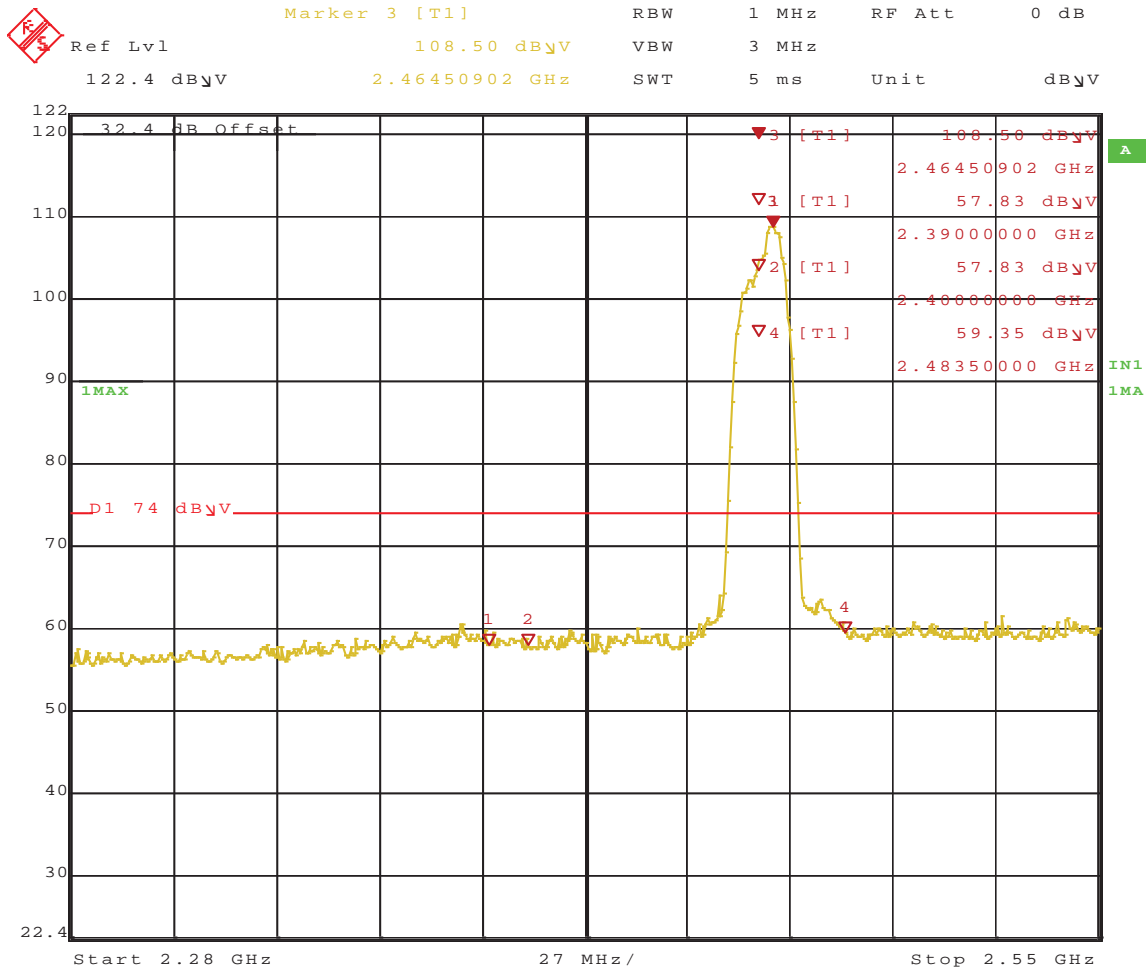

Date: 19.JAN.2011 09:44:25

Figure 285: Radiated Emission at the Edge for Channel 2462MHz at 1Mbps – Horizontal (Peak)

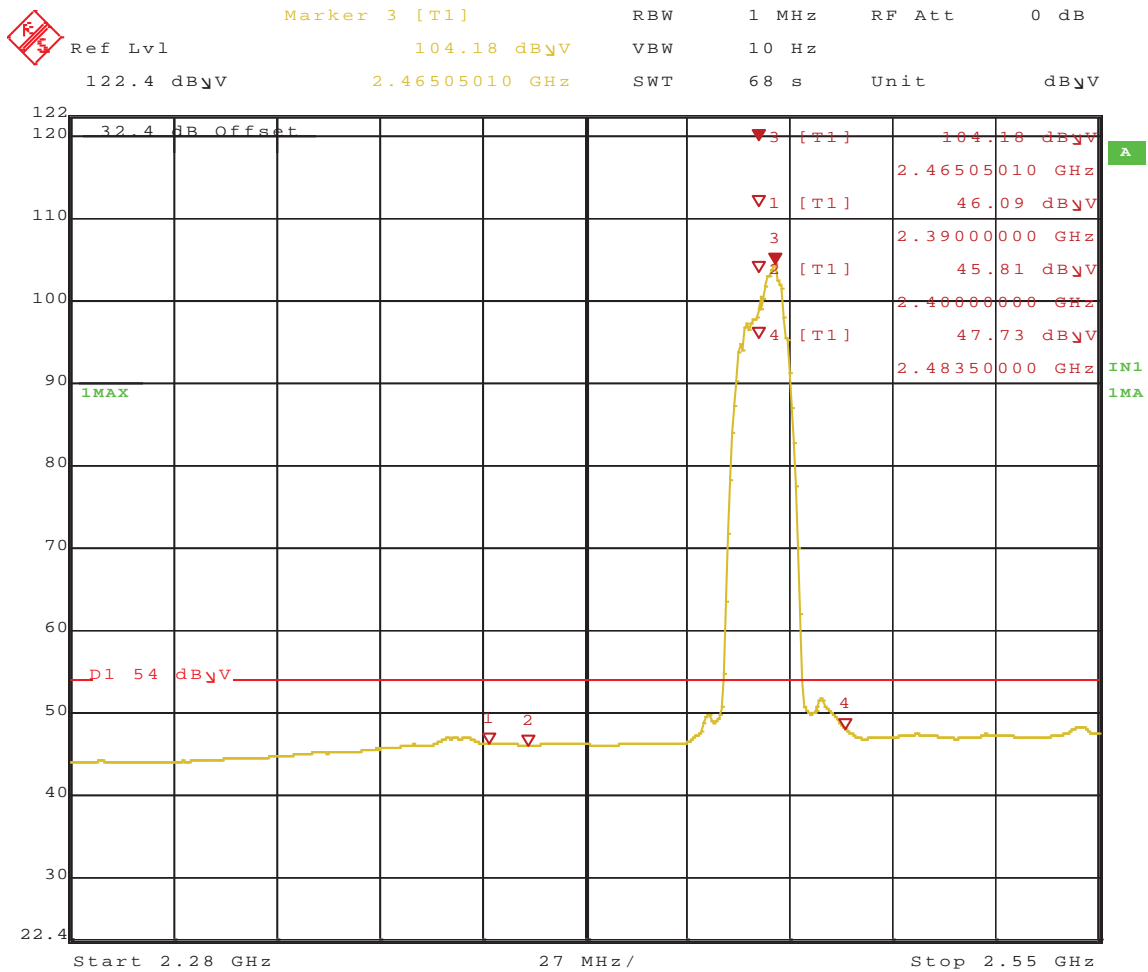

Date: 19.JAN.2011 09:46:13

Figure 286: Radiated Emission at the Edge for Channel 2462MHz at 1Mbps – Horizontal (Ave.)

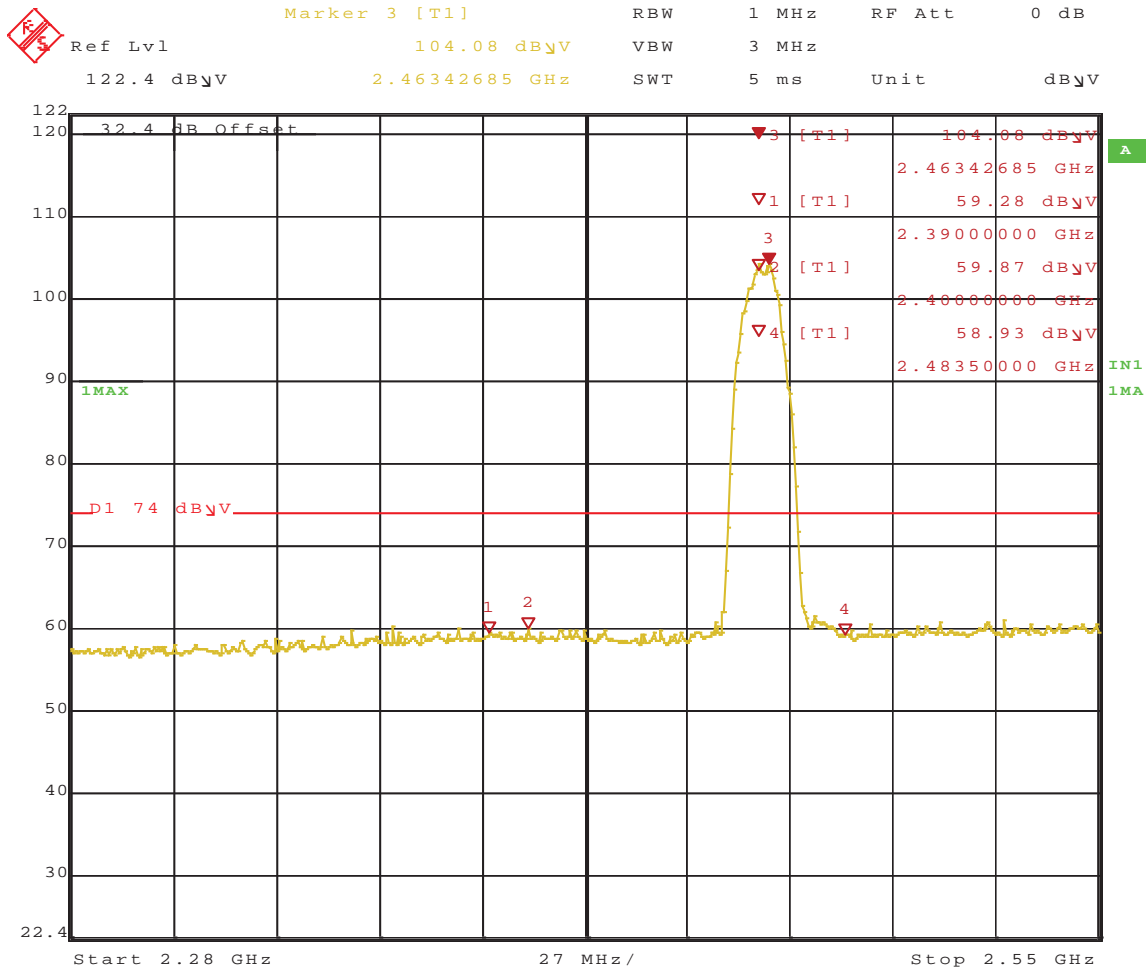

Date: 19.JAN.2011 09:48:39

Figure 287: Radiated Emission at the Edge for Channel 2462MHz at 1Mbps – Vertical (Peak)

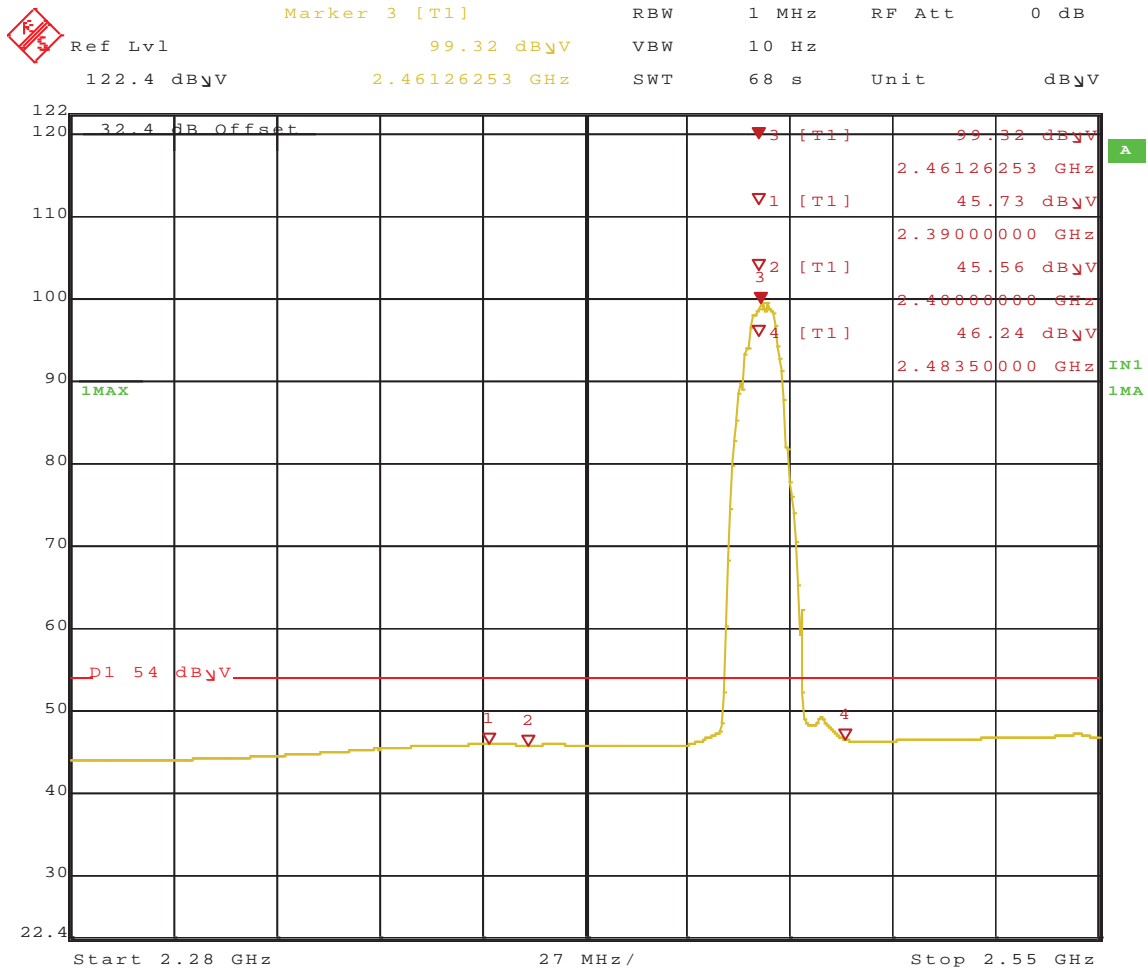

Date: 19.JAN.2011 09:50:13

Figure 288: Radiated Emission at the Edge for Channel 2462MHz at 1Mbps – Vertical (Ave.)

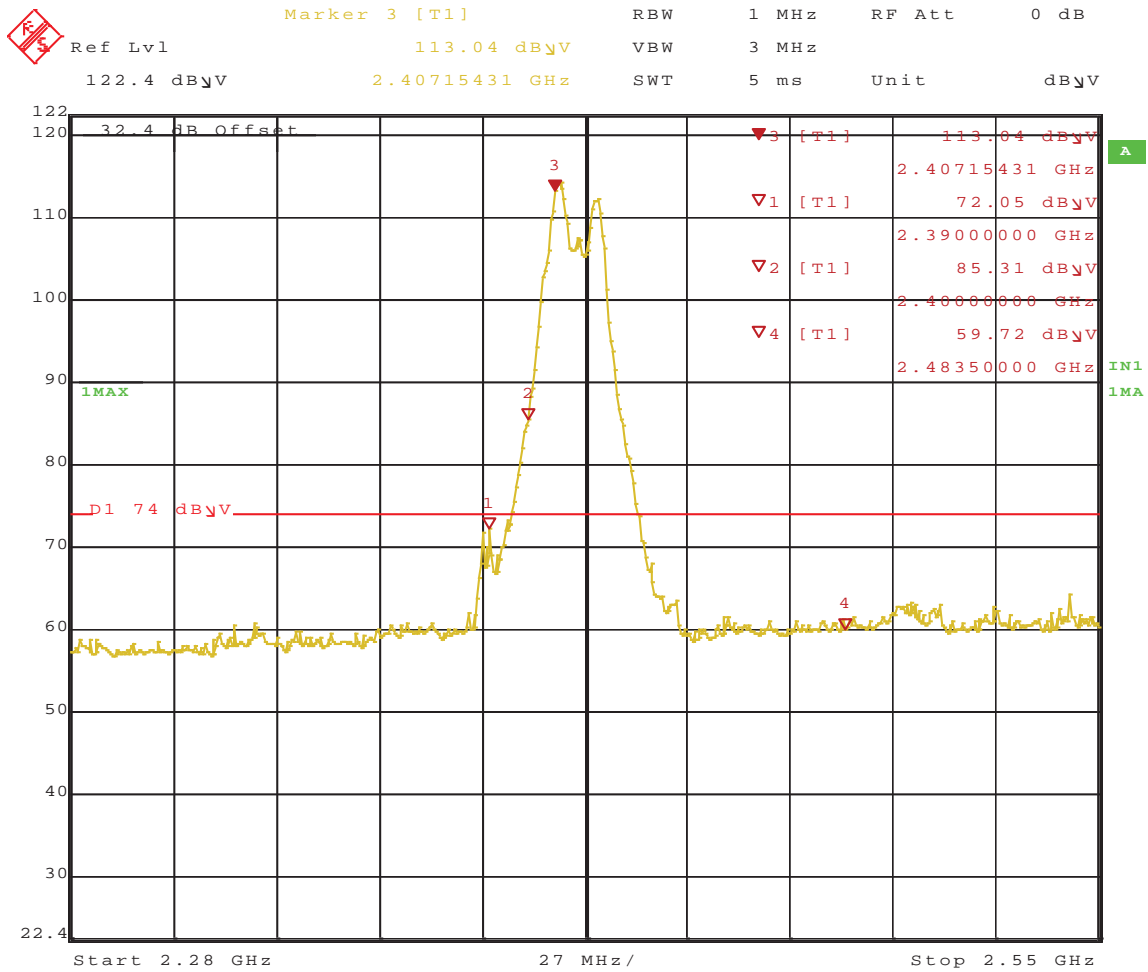

Date: 19.JAN.2011 10:26:27

Figure 289: Radiated Emission at the Edge for Channel 2412MHz at 9 Mbps – Horizontal (Peak)

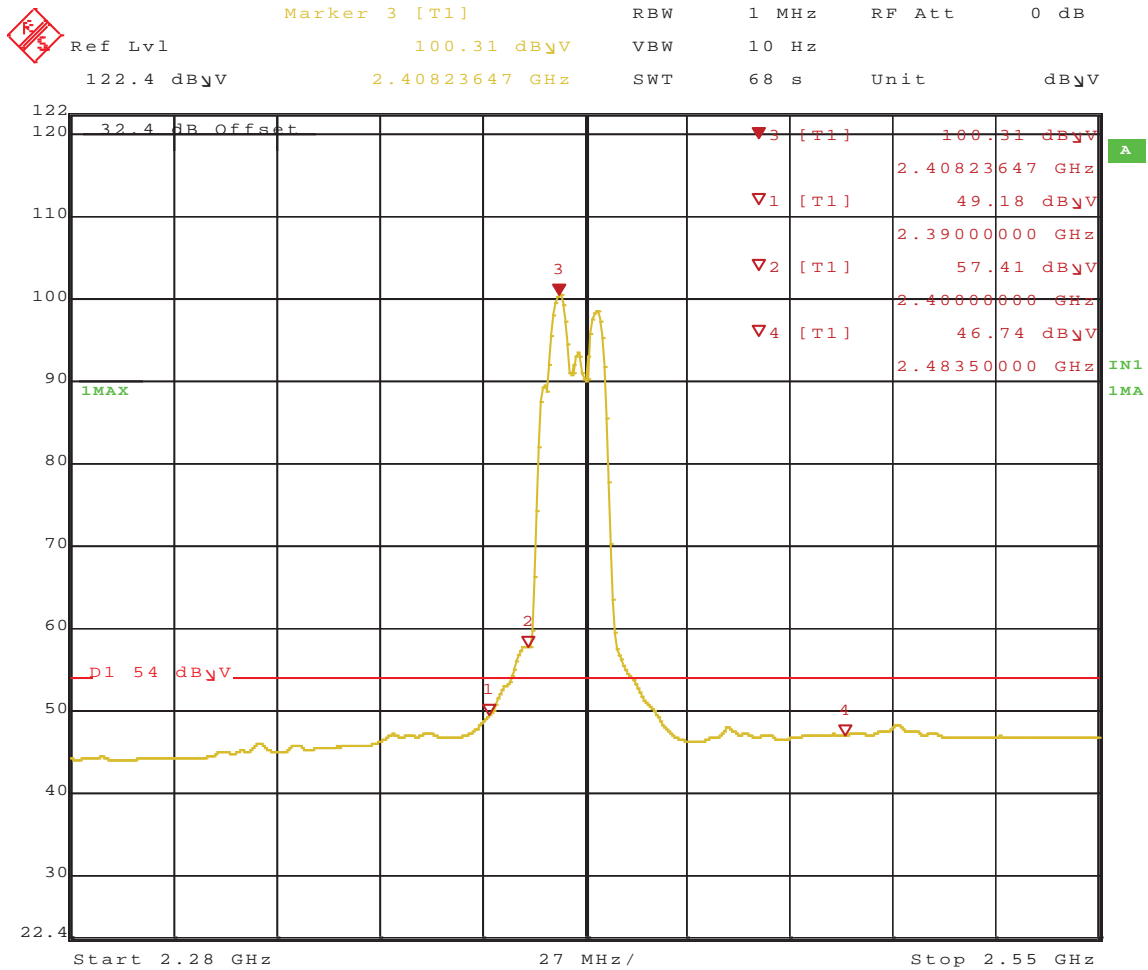

Date: 19.JAN.2011 10:28:09

Figure 290: Radiated Emission at the Edge for Channel 2412MHz at 9 Mbps – Horizontal (Ave.)

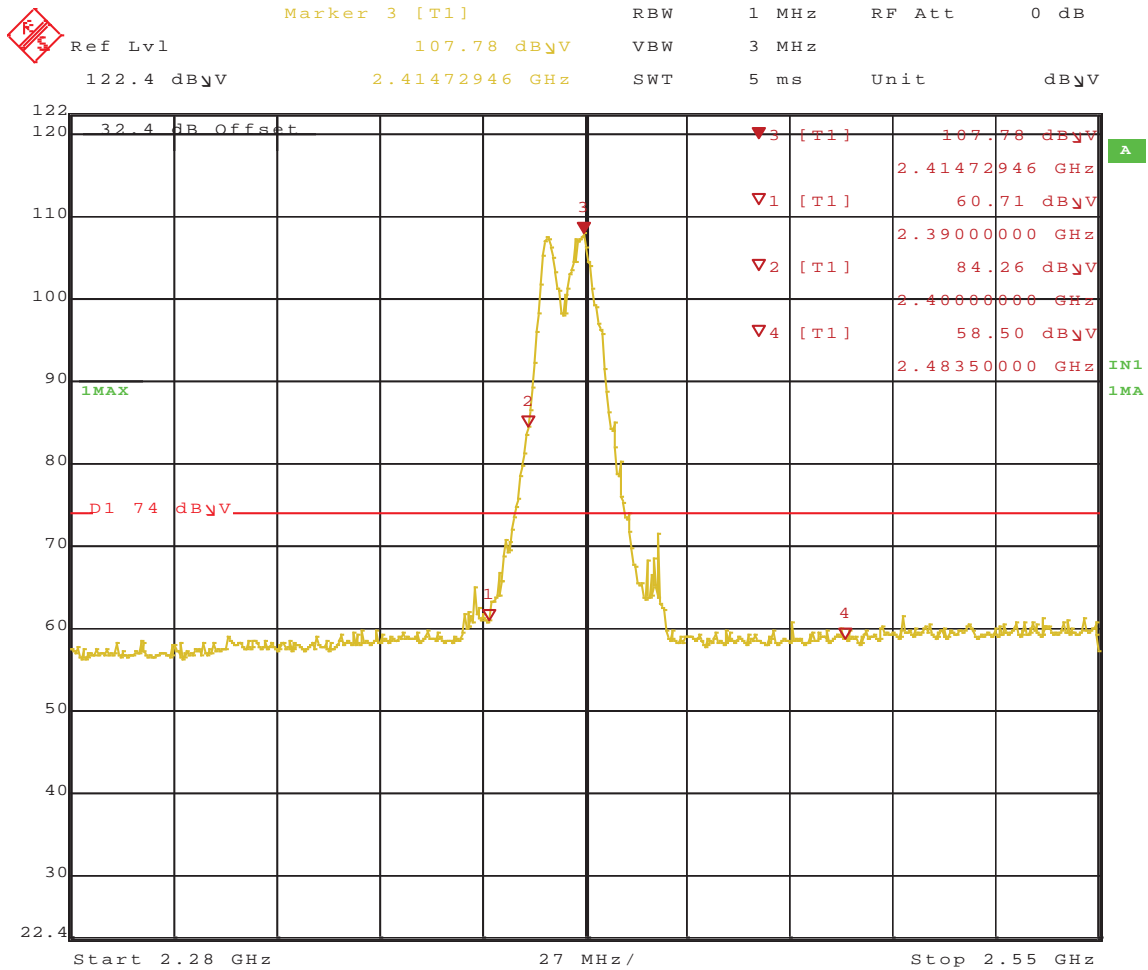

Date: 19.JAN.2011 10:31:14

Figure 291: Radiated Emission at the Edge for Channel 2412MHz at 9 Mbps – Vertical (Peak)

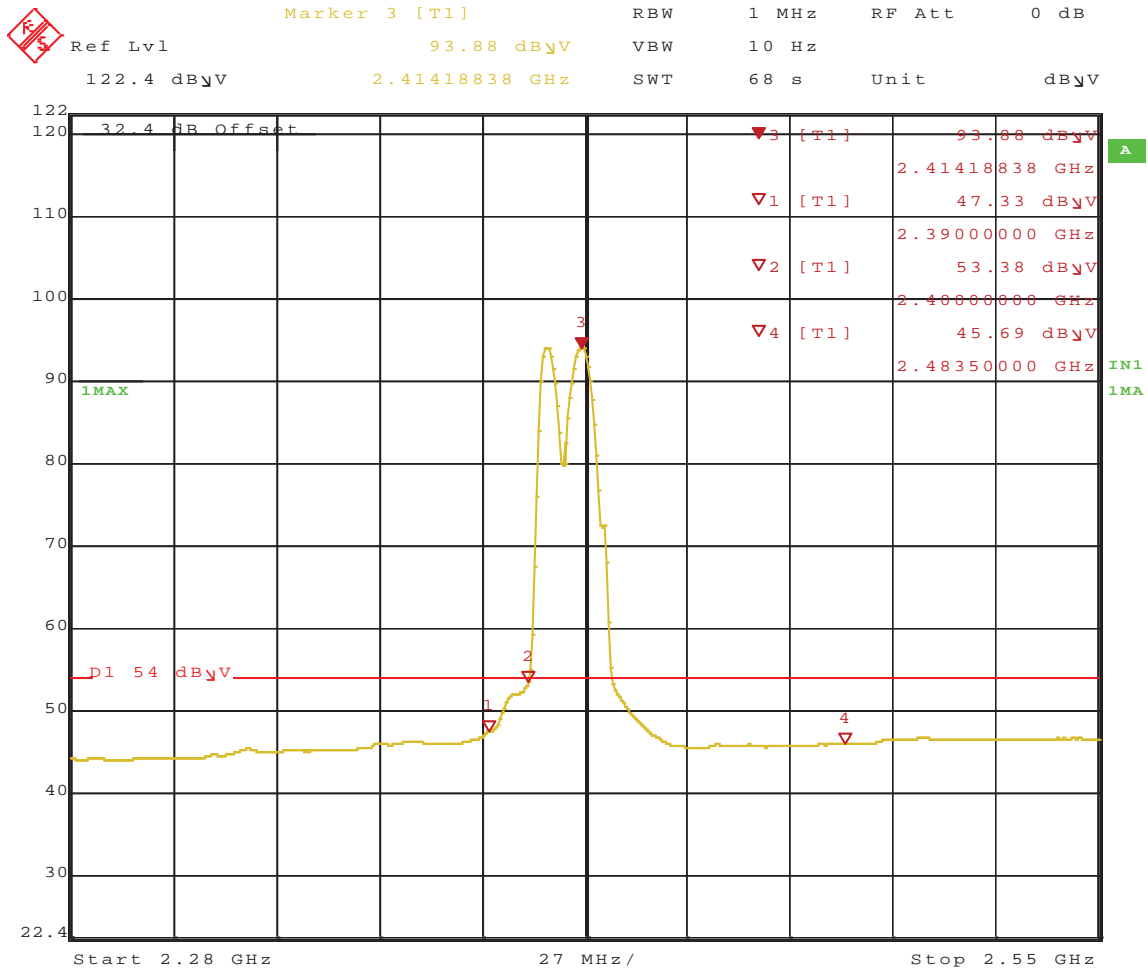

Date: 19.JAN.2011 10:32:54

Figure 292: Radiated Emission at the Edge for Channel 2412MHz at 9 Mbps – Vertical (Ave.)

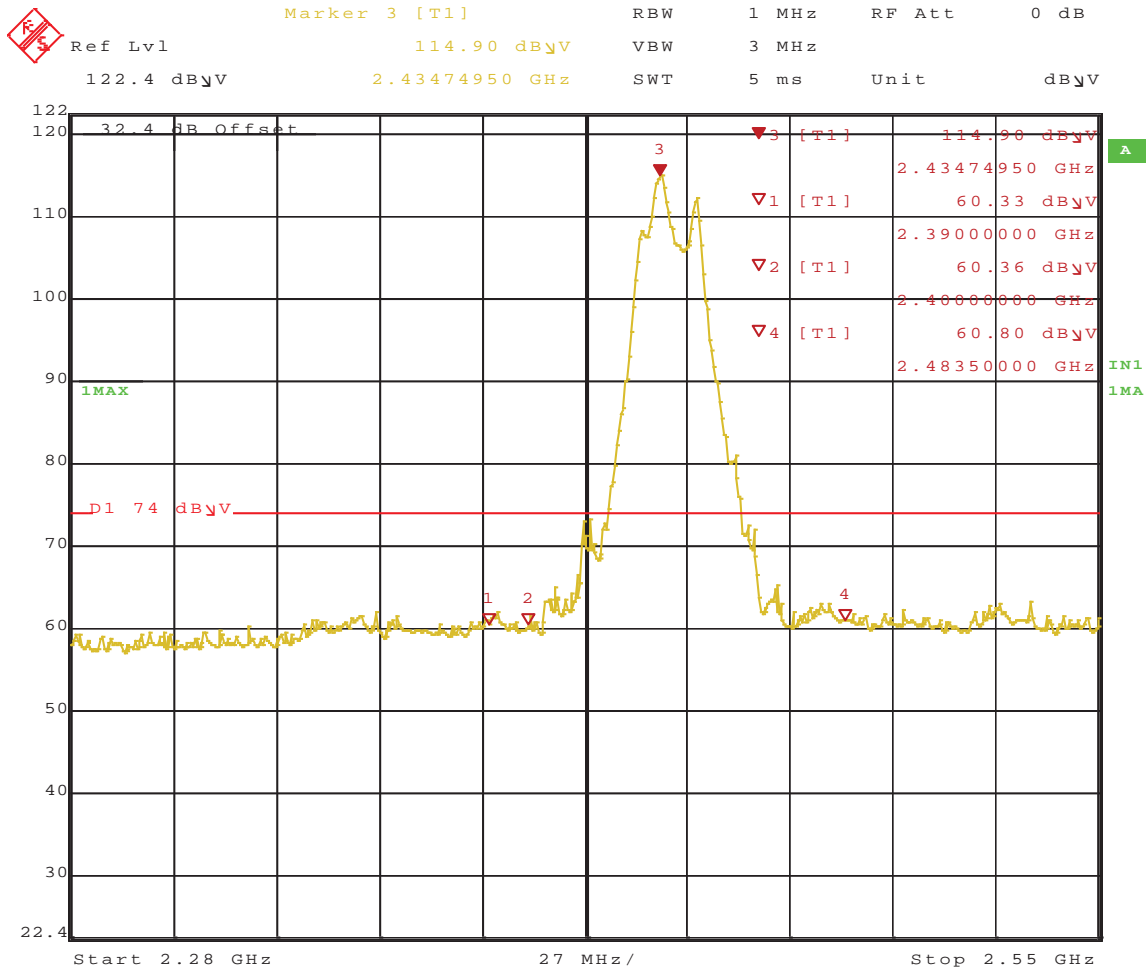

Date: 19.JAN.2011 10:36:06

Figure 293: Radiated Emission at the Edge for Channel 2437MHz at 9 Mbps – Horizontal (Peak)

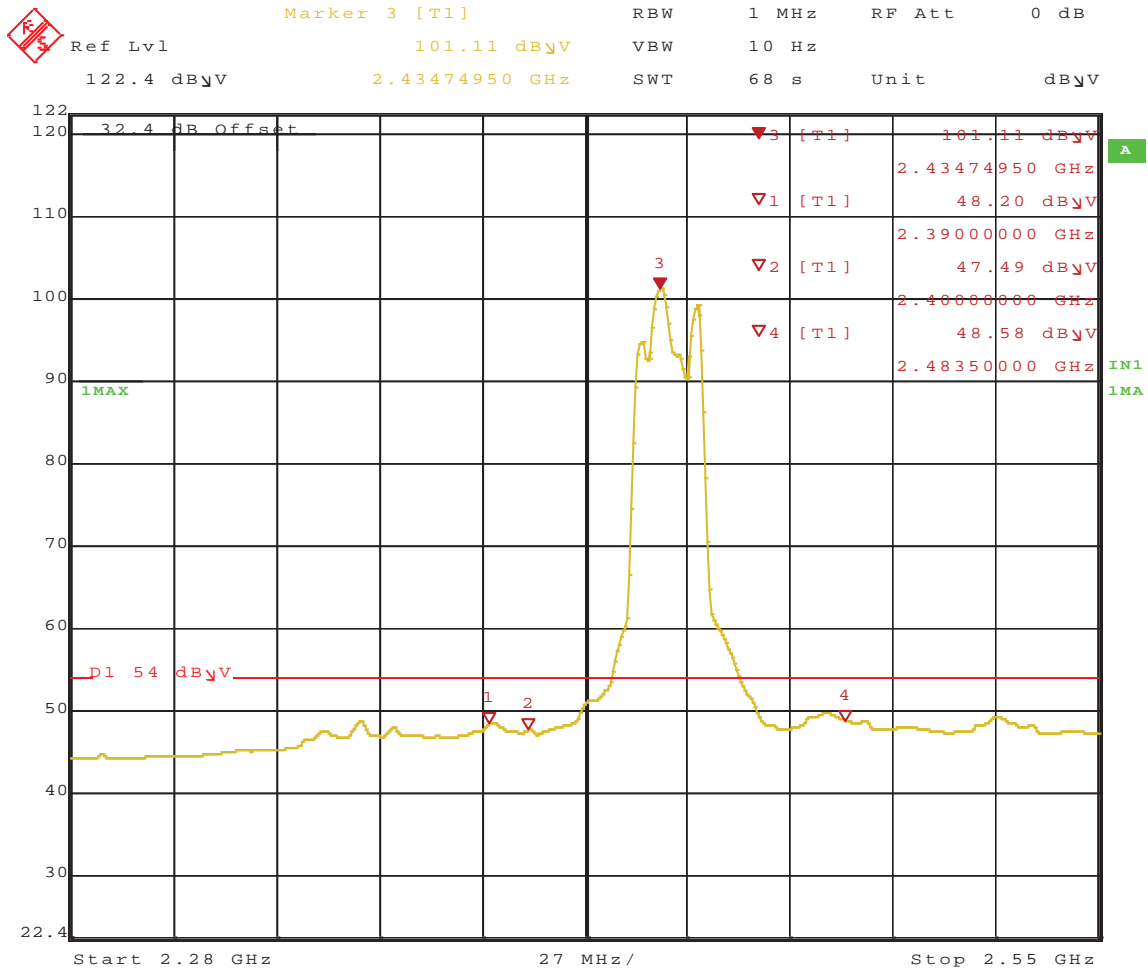

Date: 19.JAN.2011 10:37:45

Figure 294: Radiated Emission at the Edge for Channel 2437MHz at 9 Mbps – Horizontal (Ave.)

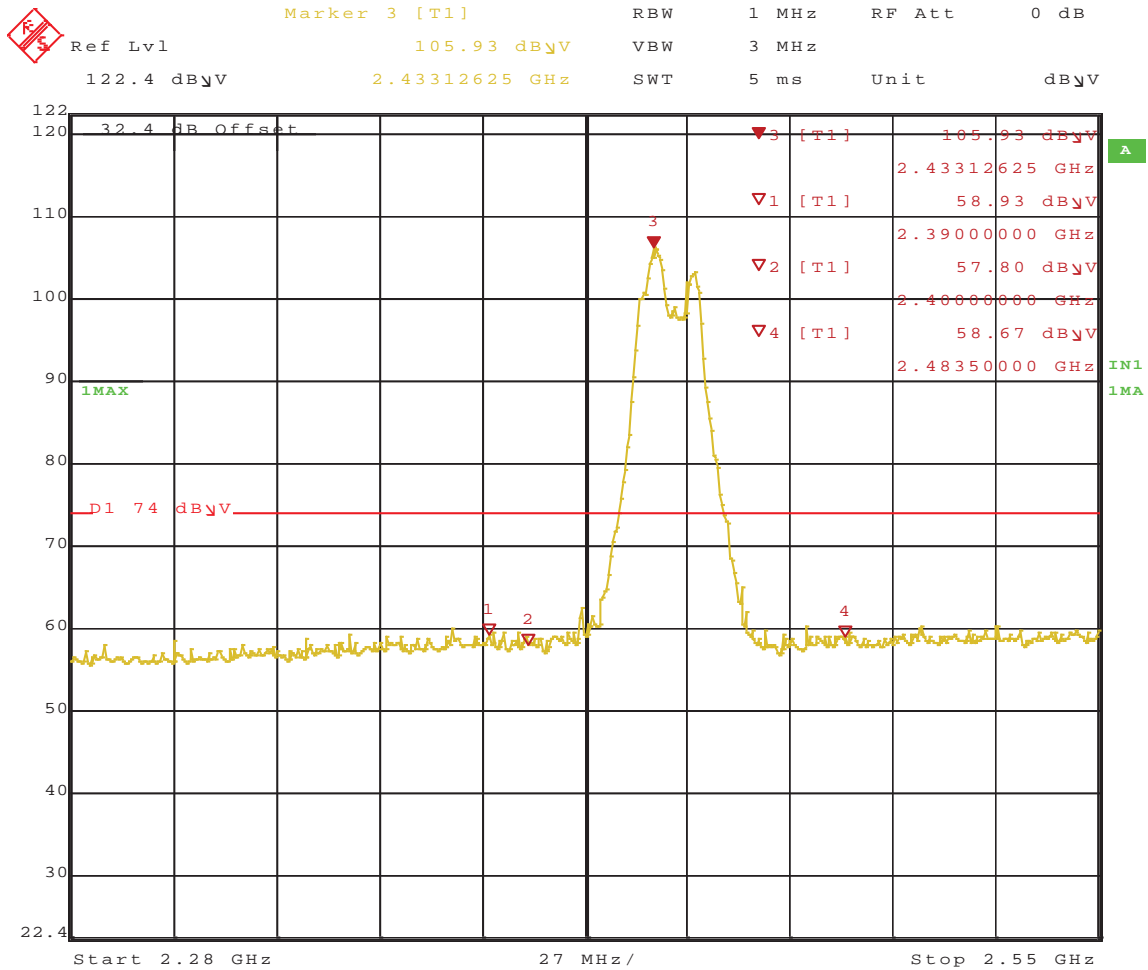

Date: 19.JAN.2011 10:39:40

Figure 295: Radiated Emission at the Edge for Channel 2437MHz at 9 Mbps – Vertical (Peak)

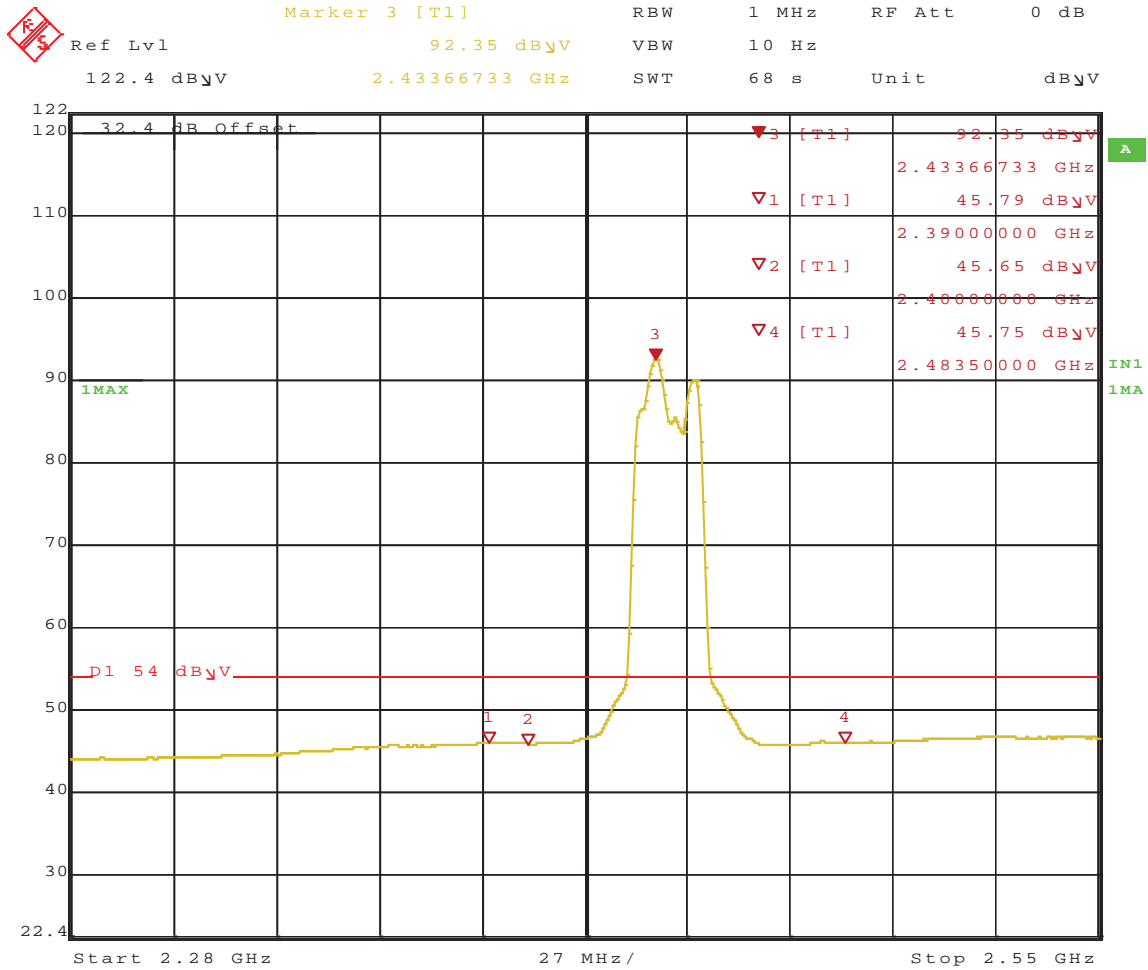

Date: 19.JAN.2011 10:41:21

Figure 296: Radiated Emission at the Edge for Channel 2437MHz at 9 Mbps – Vertical (Ave.)

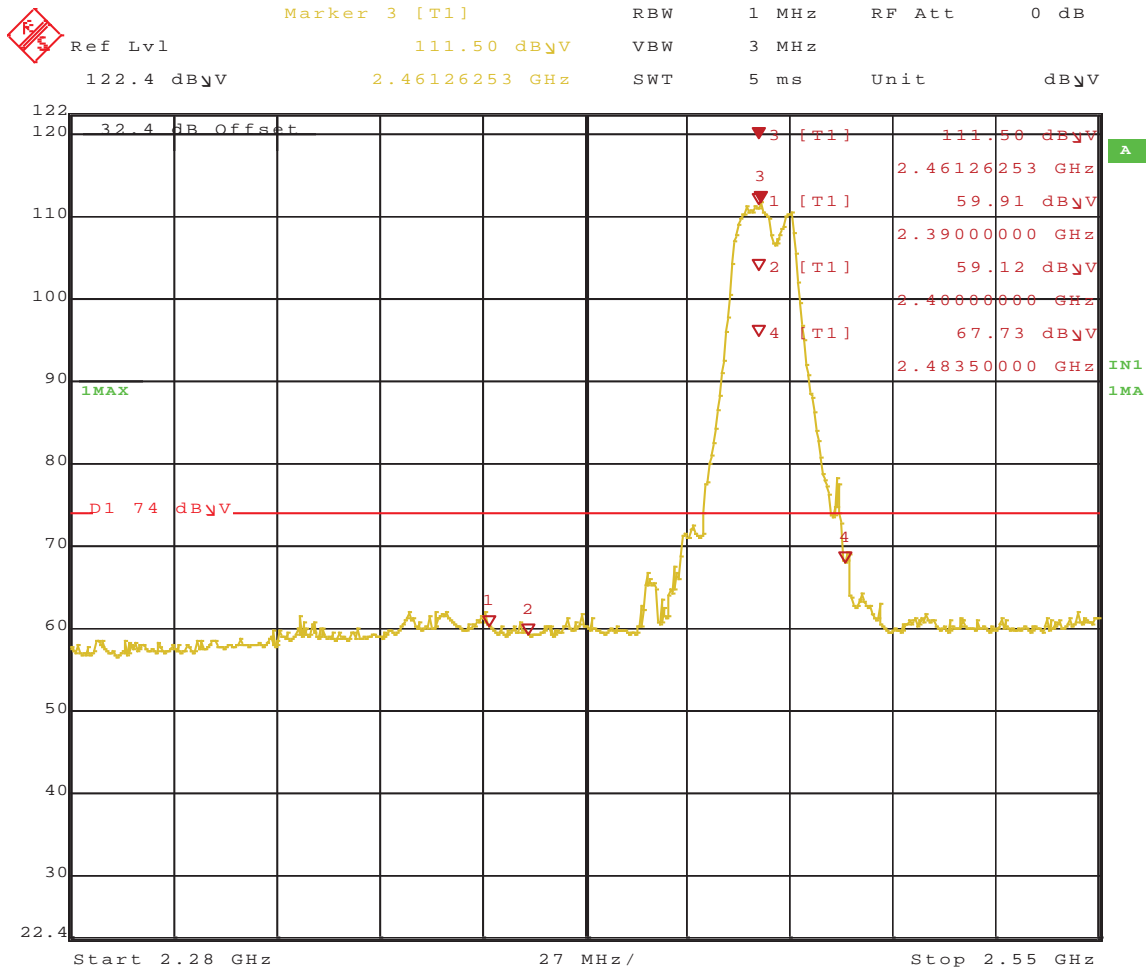

Date: 19.JAN.2011 10:44:18

Figure 297: Radiated Emission at the Edge for Channel 2462MHz at 9 Mbps – Horizontal (Peak)

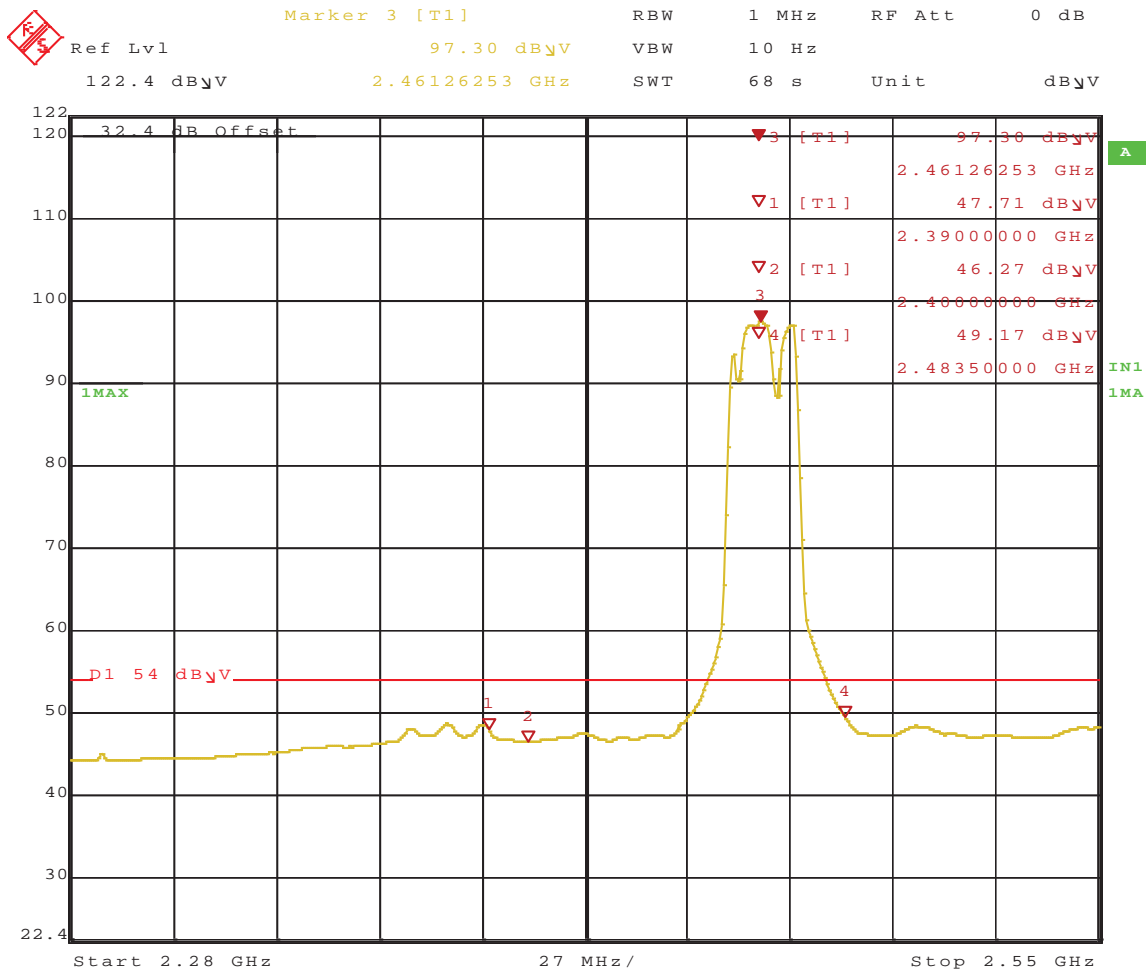

Date: 19.JAN.2011 10:46:10

Figure 298: Radiated Emission at the Edge for Channel 2462MHz at 9 Mbps – Horizontal (Ave.)

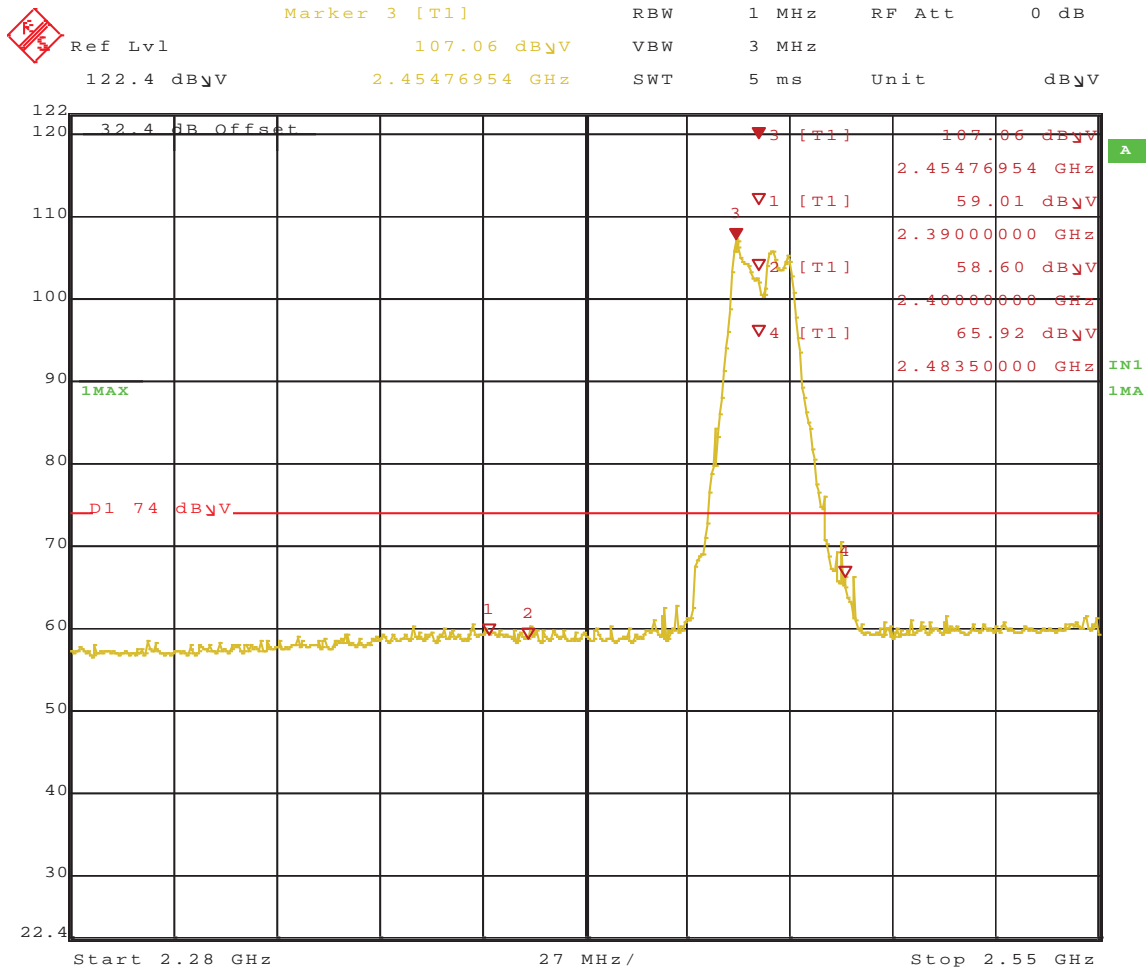

Date: 19.JAN.2011 10:49:19

Figure 299: Radiated Emission at the Edge for Channel 2462MHz at 9 Mbps – Vertical (Peak)

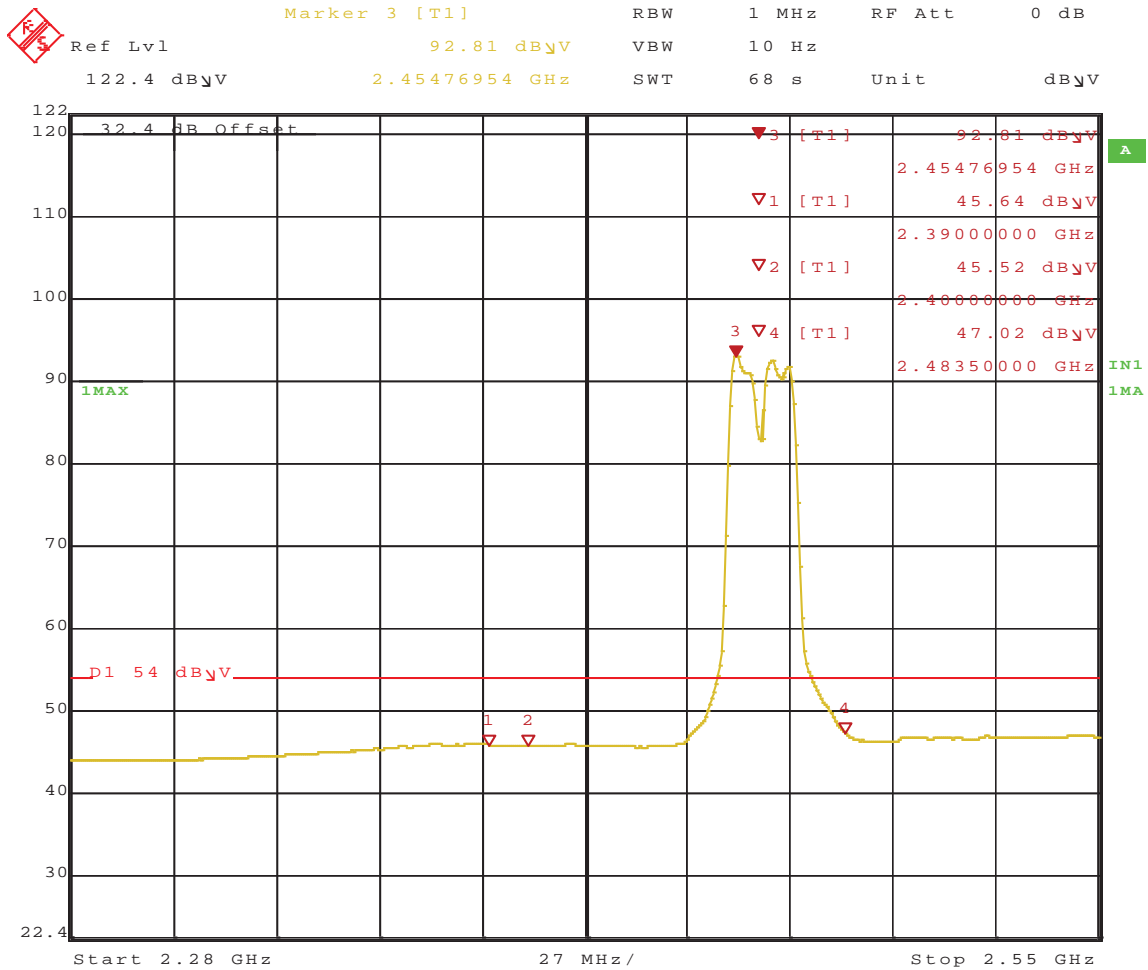

Date: 19.JAN.2011 10:50:55

Figure 300: Radiated Emission at the Edge for Channel 2462MHz at 9 Mbps – Vertical (Ave.)

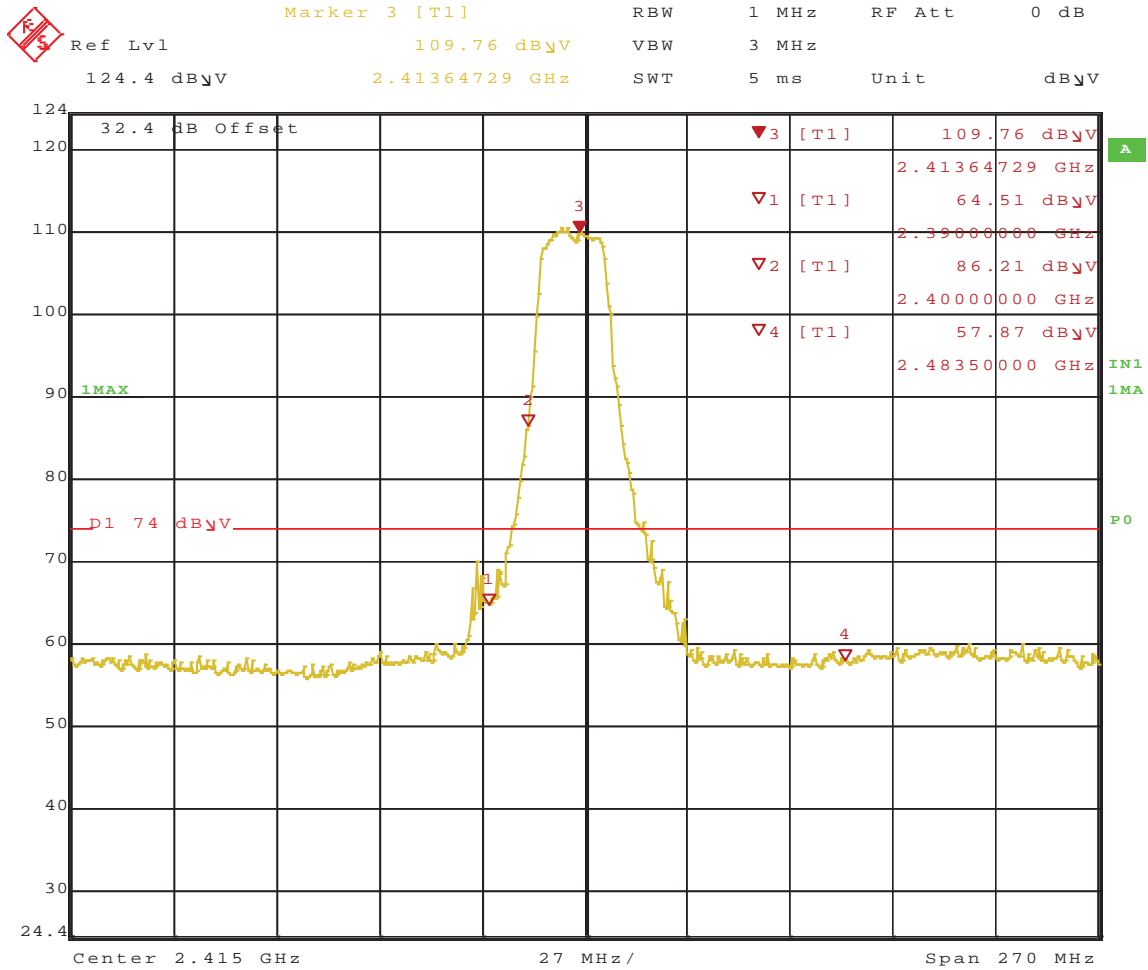

Date: 19.JAN.2011 15:16:23

Figure 301: Radiated Emission at the Edge for Channel 2412MHz at Chain 1 HT20 58.5 Mbps – Horizontal (Peak)

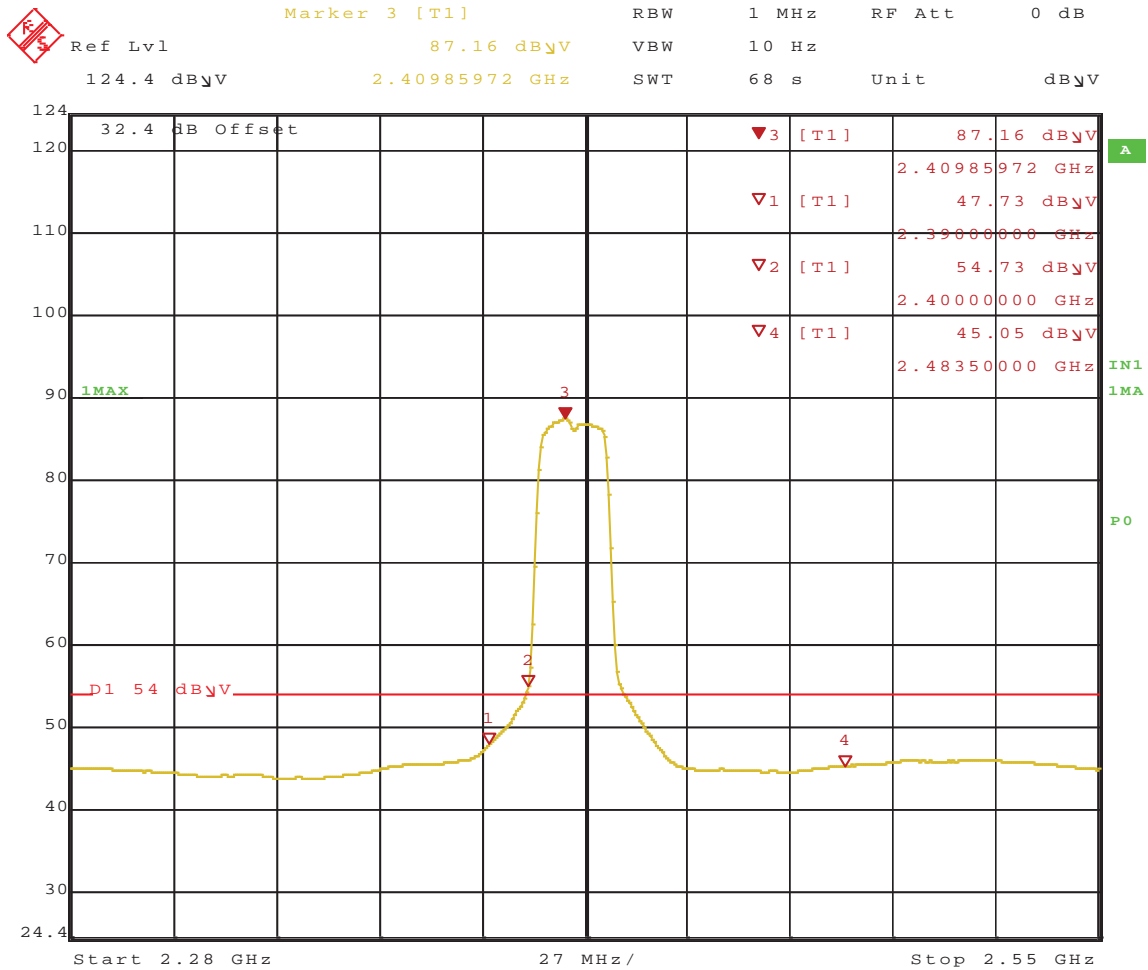

Date: 19.JAN.2011 15:20:29

Figure 302: Radiated Emission at the Edge for Channel 2412MHz at Chain 1 HT20 58.5 Mbps – Horizontal (Ave.)

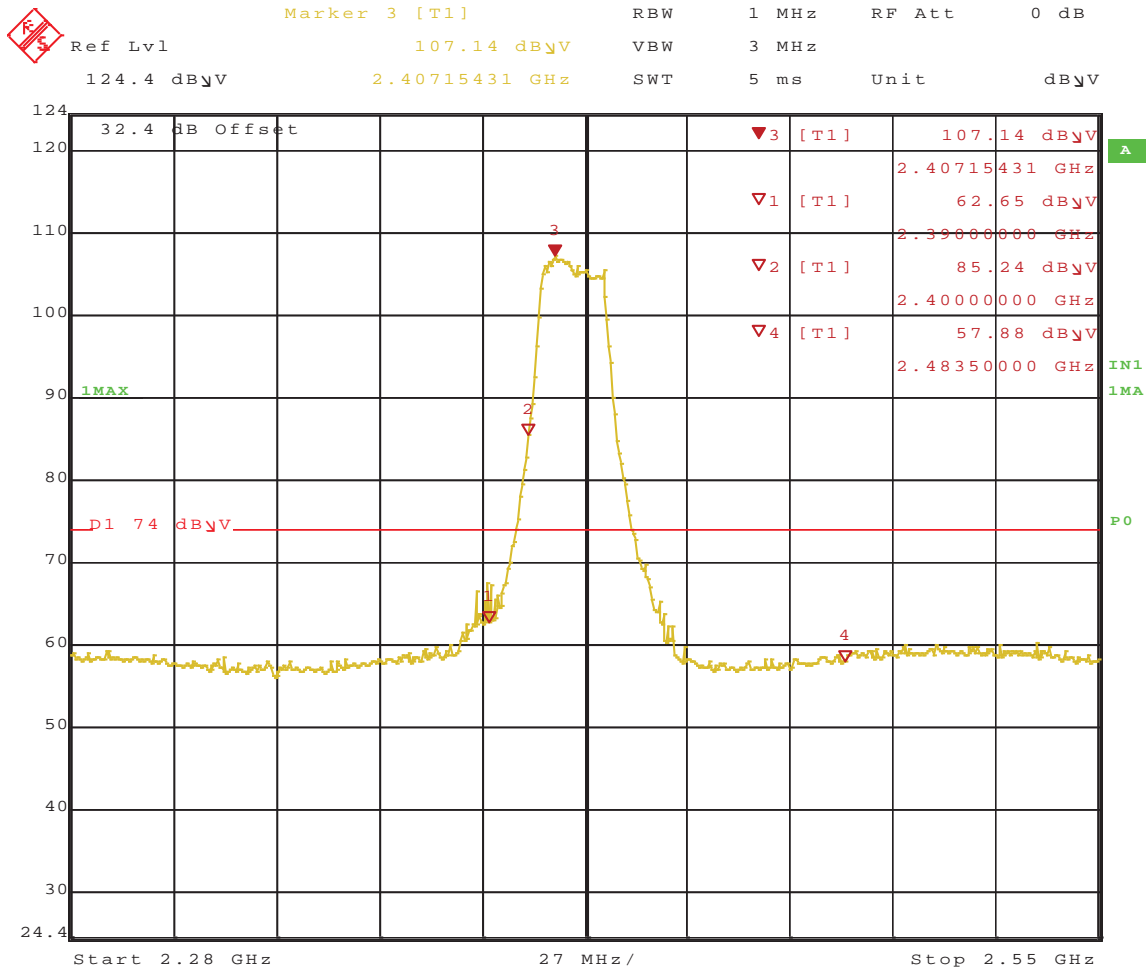

Date: 19.JAN.2011 15:22:52

Figure 303: Radiated Emission at the Edge for Channel 2412MHz at Chain 1 HT20 58.5 Mbps – Vertical (Peak)

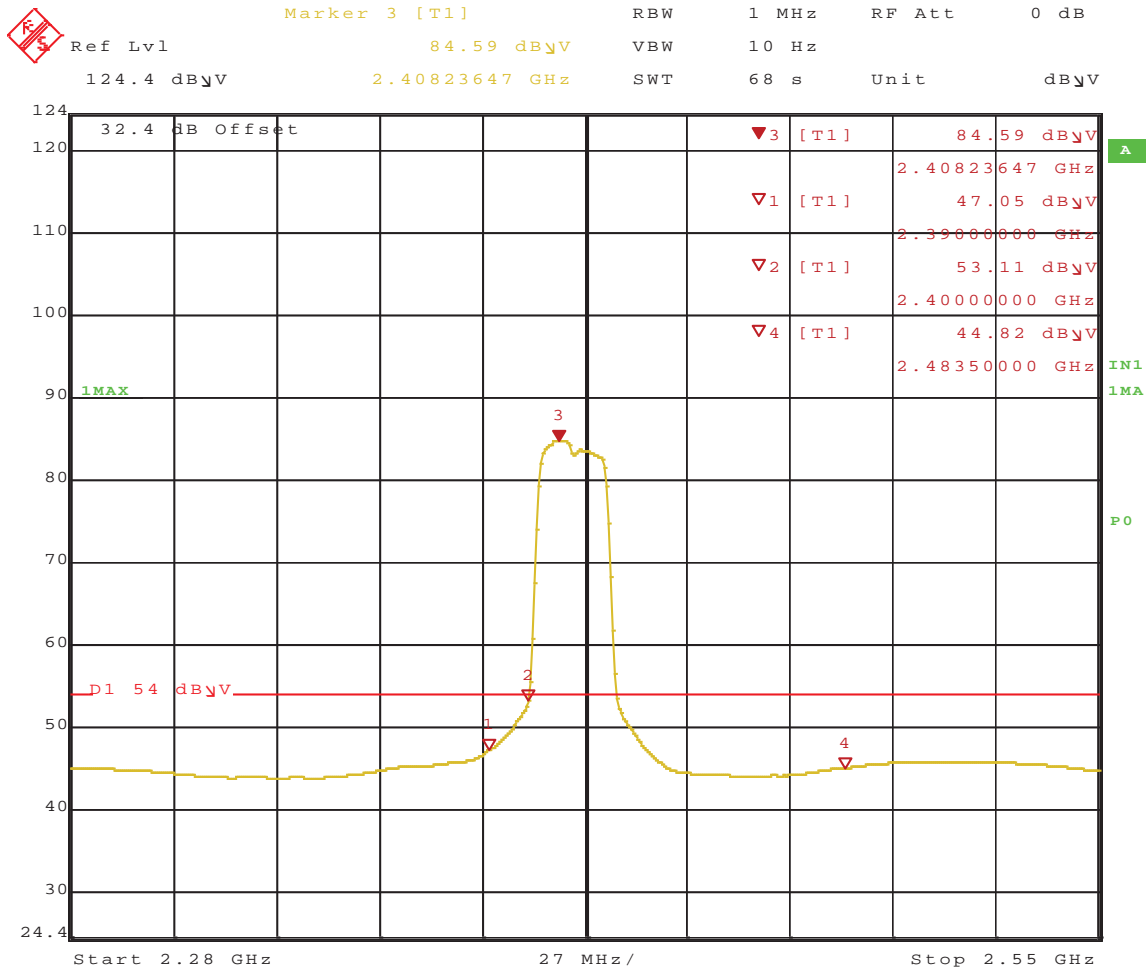

Date: 19.JAN.2011 15:24:26

Figure 304: Radiated Emission at the Edge for Channel 2412MHz at Chain 1 HT20 58.5 Mbps – Vertical (Ave.)

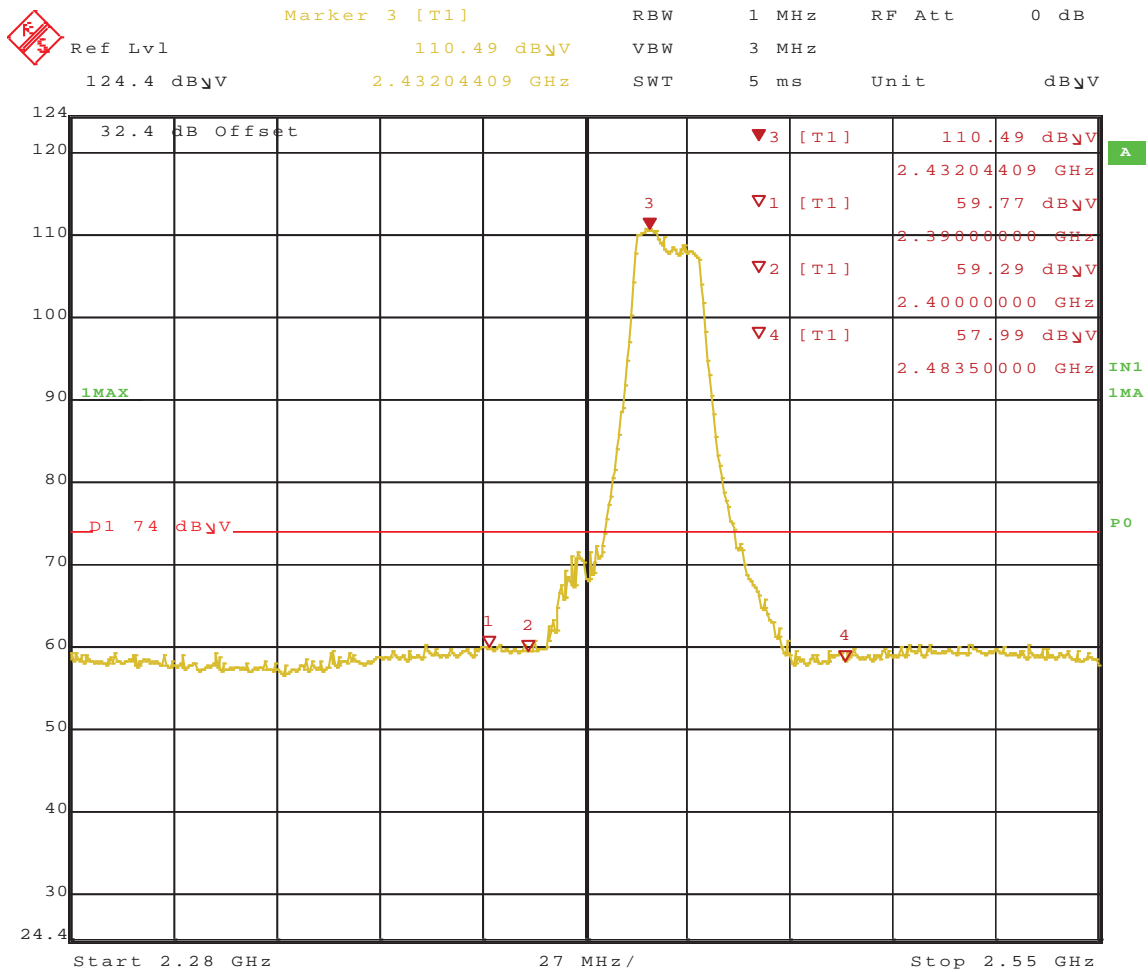

Date: 19.JAN.2011 15:33:05

Figure 305: Radiated Emission at the Edge for Channel 2437MHz at Chain 1 HT20 58.5 Mbps – Horizontal (Peak)

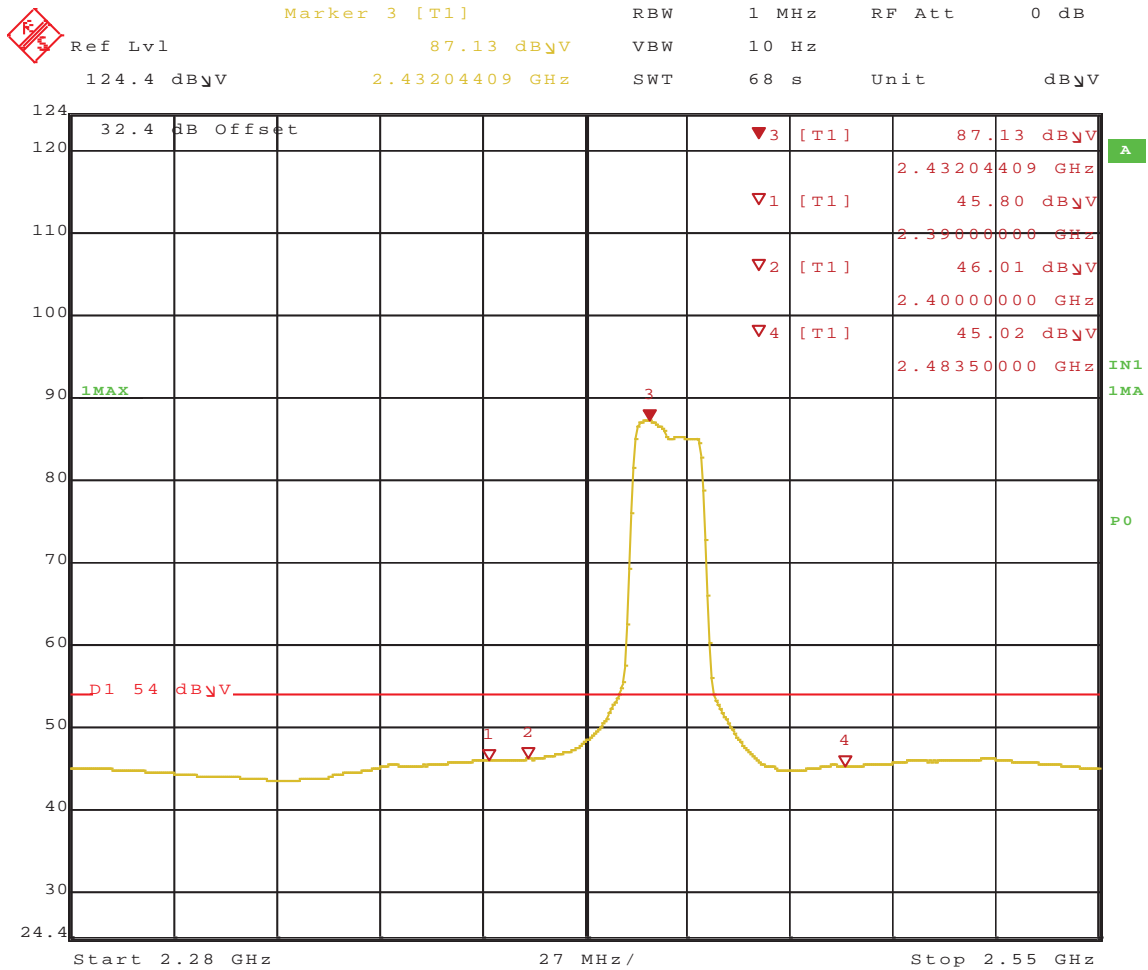

Date: 19.JAN.2011 15:34:41

Figure 306: Radiated Emission at the Edge for Channel 2437MHz at Chain 1 HT20 58.5 Mbps – Horizontal (Ave.)

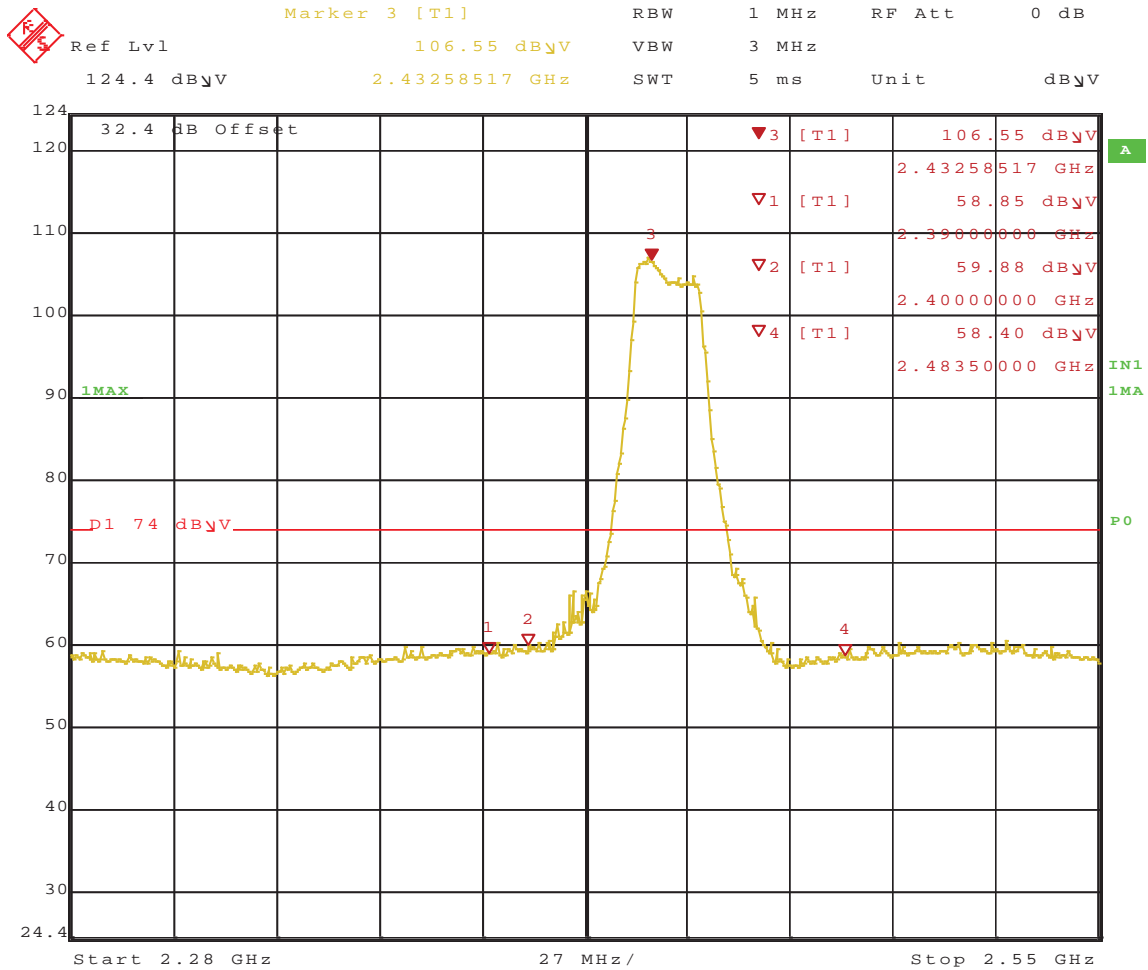

Date: 19.JAN.2011 15:28:13

Figure 307: Radiated Emission at the Edge for Channel 2437MHz at Chain 1 HT20 58.5 Mbps – Vertical (Peak)

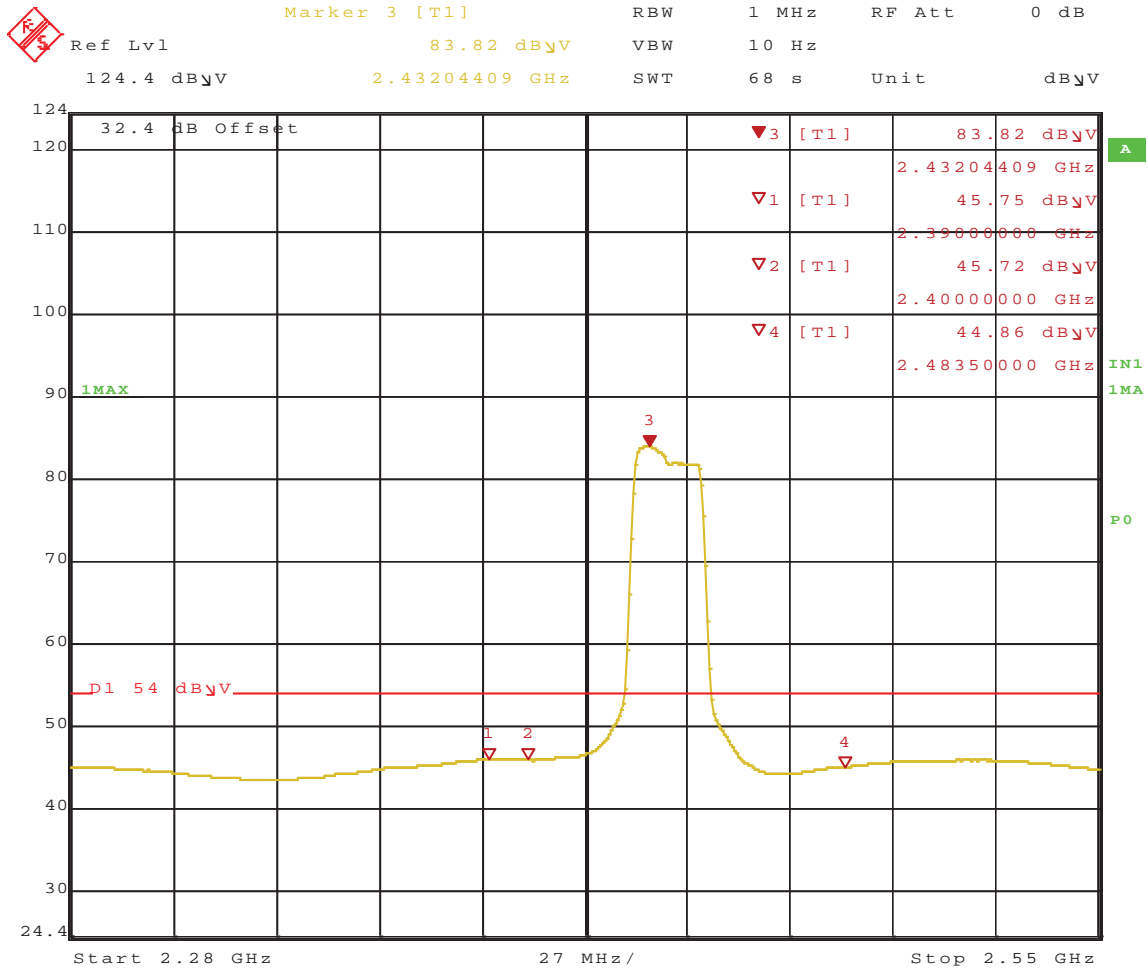

Date: 19.JAN.2011 15:29:55

Figure 308: Radiated Emission at the Edge for Channel 2437MHz at Chain 1 HT20 58.5 Mbps – Vertical (Ave.)

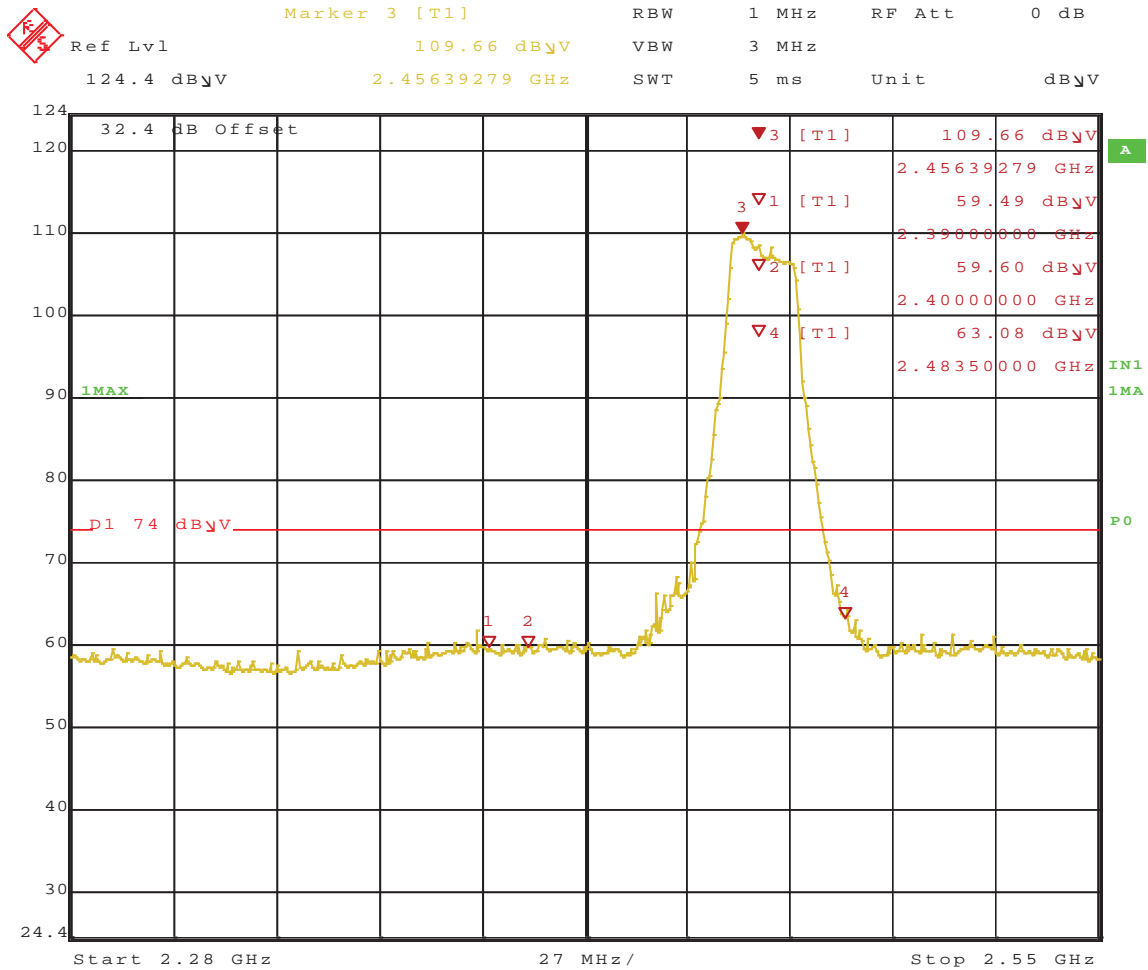

Date: 19.JAN.2011 15:37:26

Figure 309: Radiated Emission at the Edge for Channel 2462MHz at Chain 1 HT20 58.5 Mbps – Horizontal (Peak)

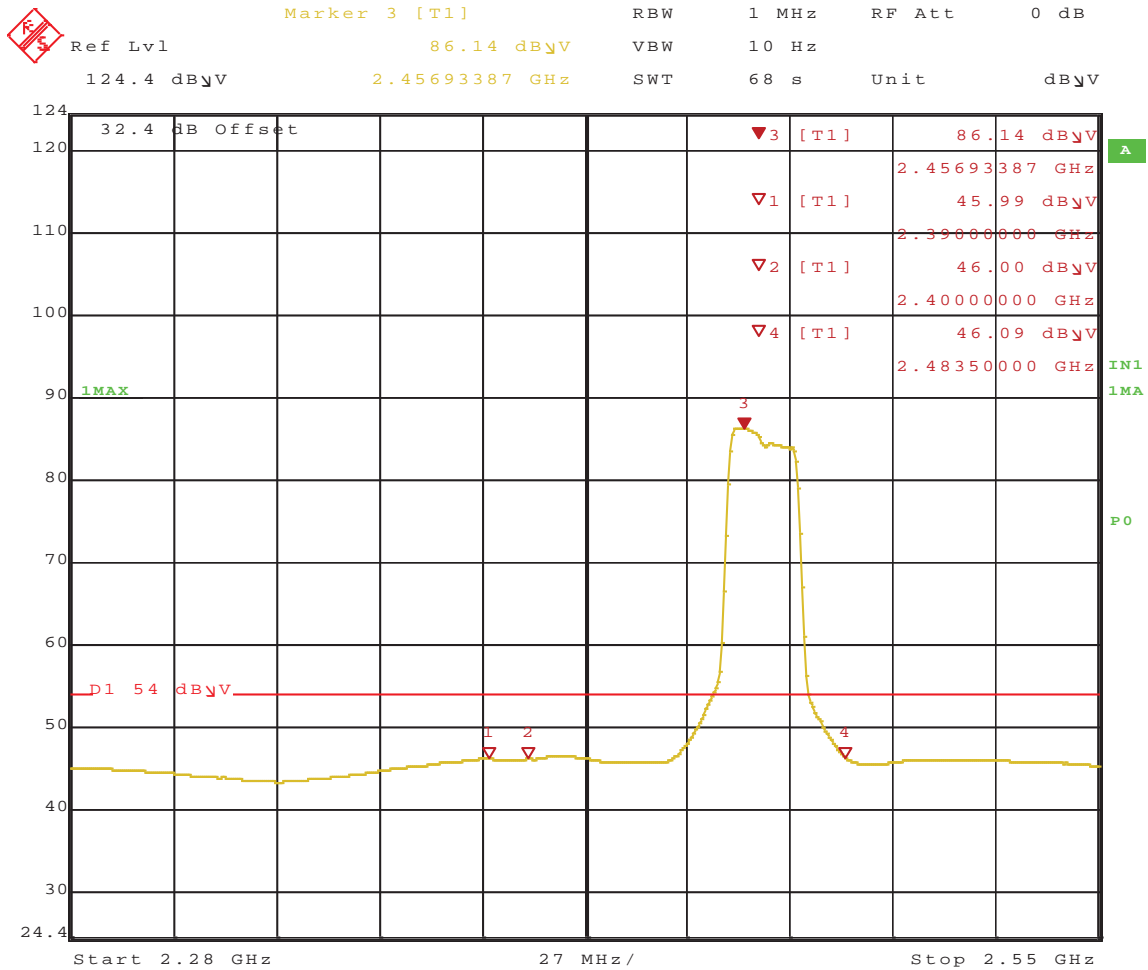

Date: 19.JAN.2011 15:39:04

Figure 310: Radiated Emission at the Edge for Channel 2462MHz at Chain 1 HT20 58.5 Mbps – Horizontal (Ave.)

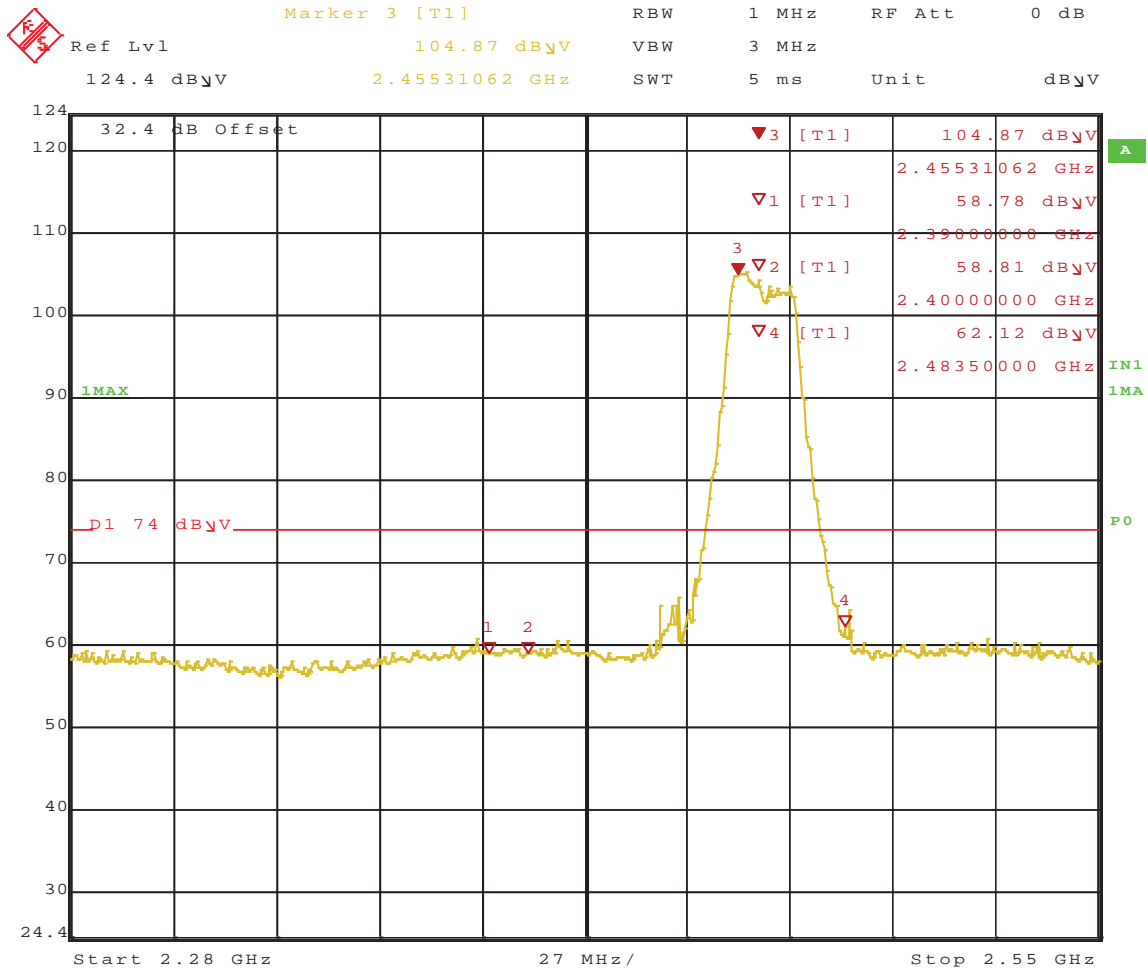

Date: 19.JAN.2011 15:41:49

Figure 311: Radiated Emission at the Edge for Channel 2462MHz at Chain 1 HT20 58.5 Mbps – Vertical (Peak)

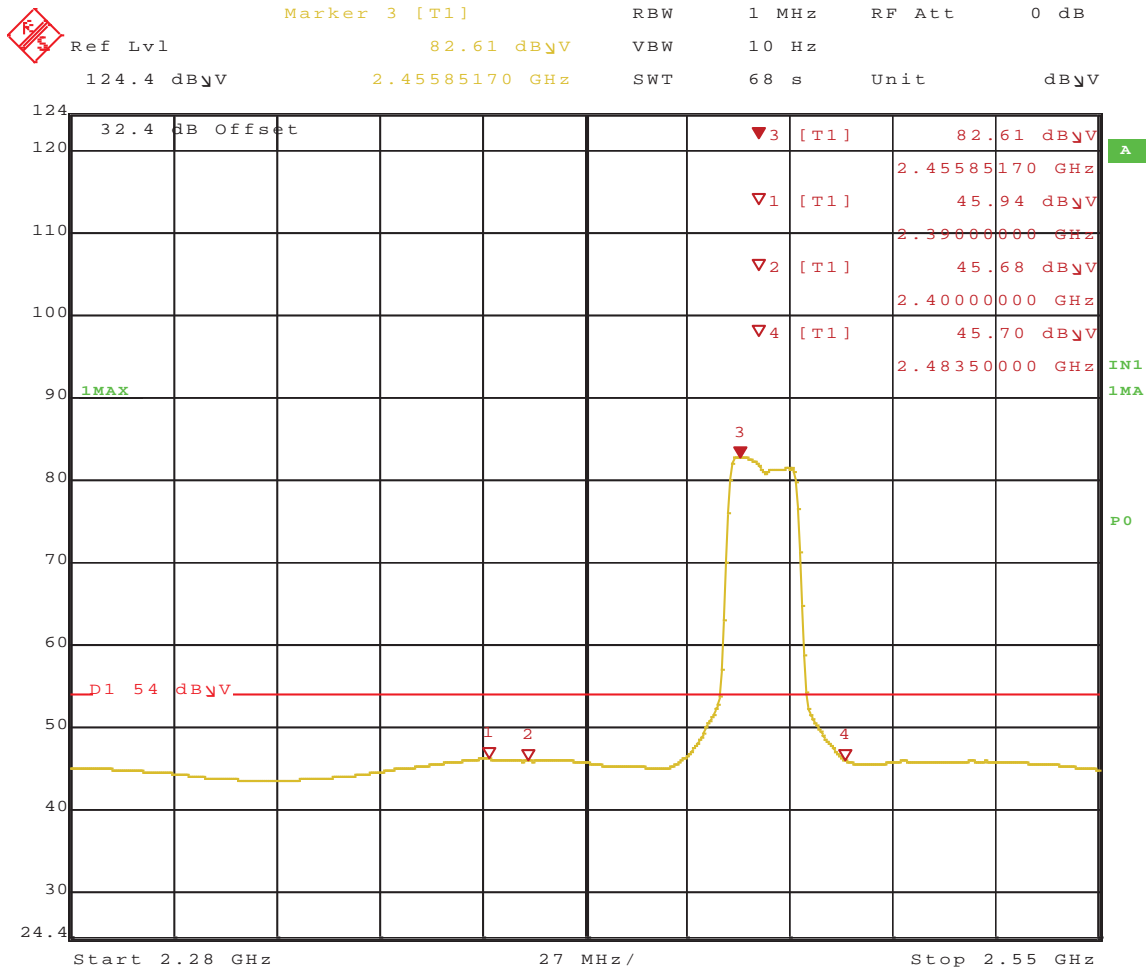

Date: 19.JAN.2011 15:43:21

Figure 312: Radiated Emission at the Edge for Channel 2462MHz at Chain 1 HT20 58.5 Mbps – Vertical (Ave.)

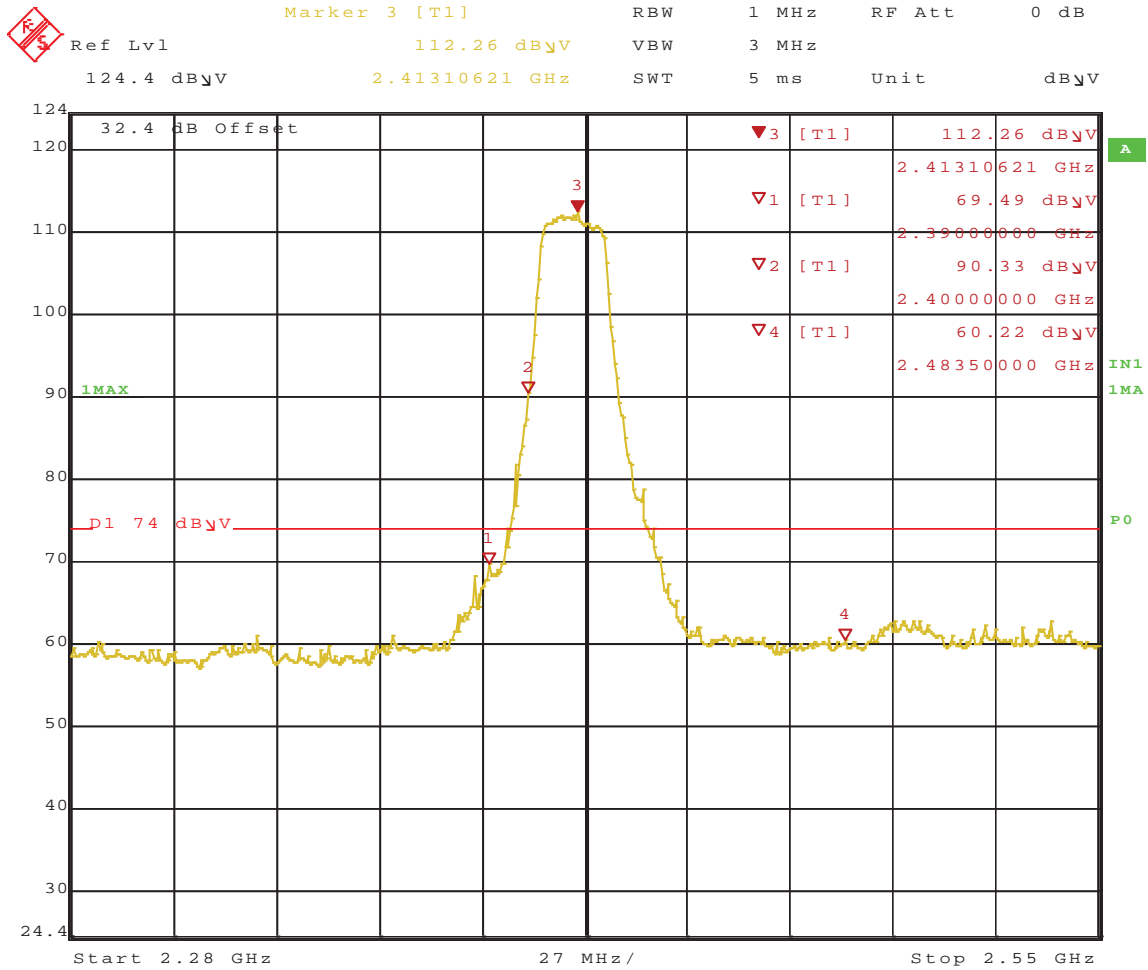

Date: 19.JAN.2011 15:52:36

Figure 313: Radiated Emission at the Edge for Channel 2412MHz at Chain 0 and 1 HT20 13 Mbps – Horizontal (Peak)

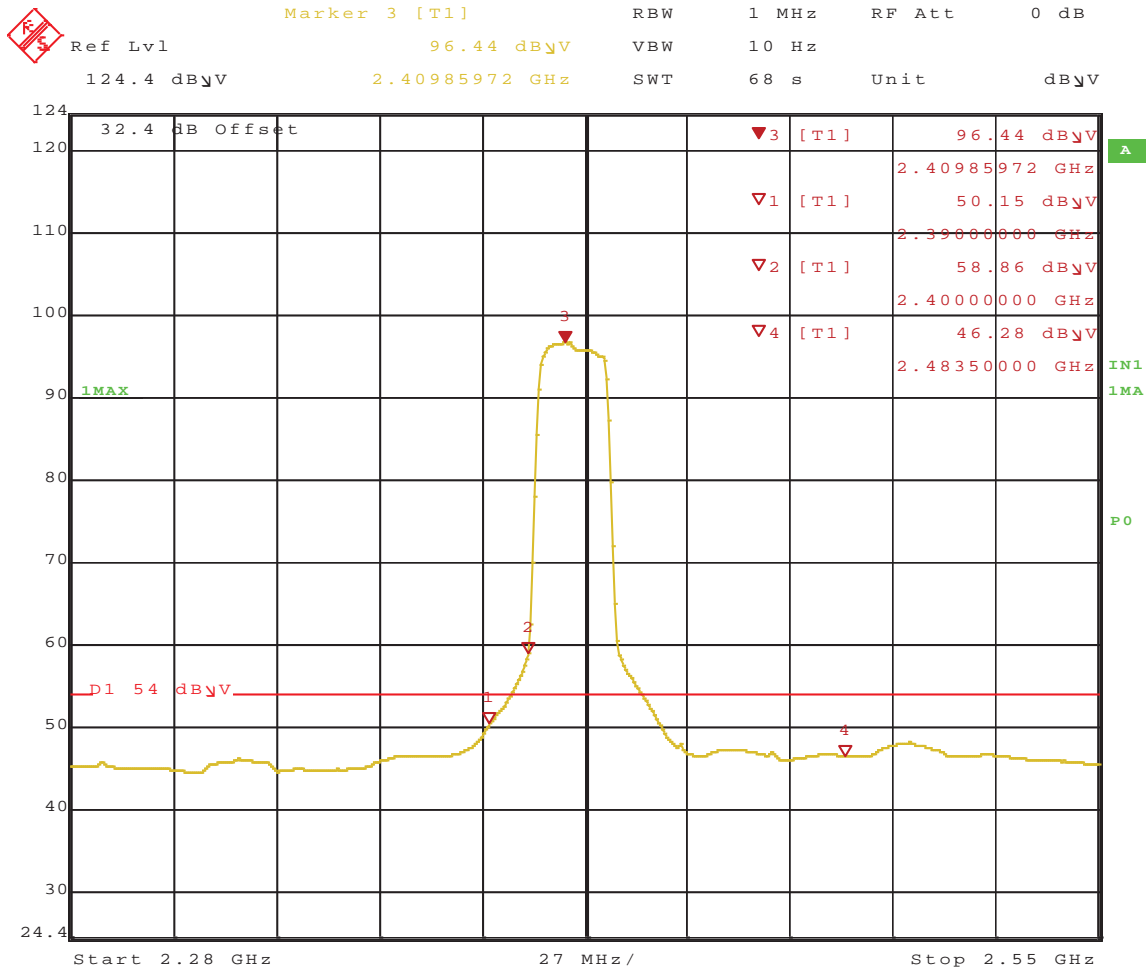

Date: 19.JAN.2011 15:54:23

Figure 314: Radiated Emission at the Edge for Channel 2412MHz at Chain 0 and 1 HT20 13 Mbps – Horizontal (Ave.)

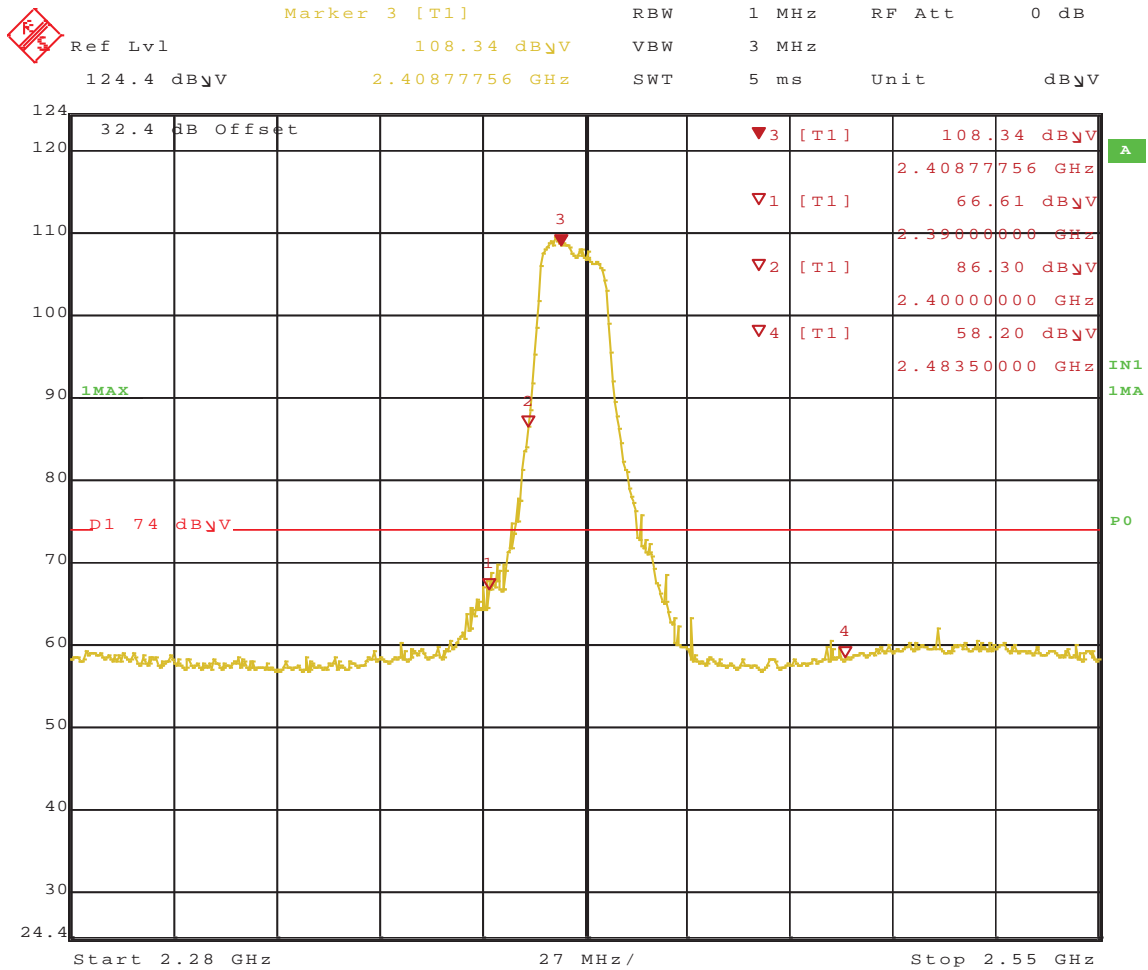

Date: 19.JAN.2011 15:47:08

Figure 315: Radiated Emission at the Edge for Channel 2412MHz at Chain 0 and 1 HT20 13 Mbps – Vertical (Peak)

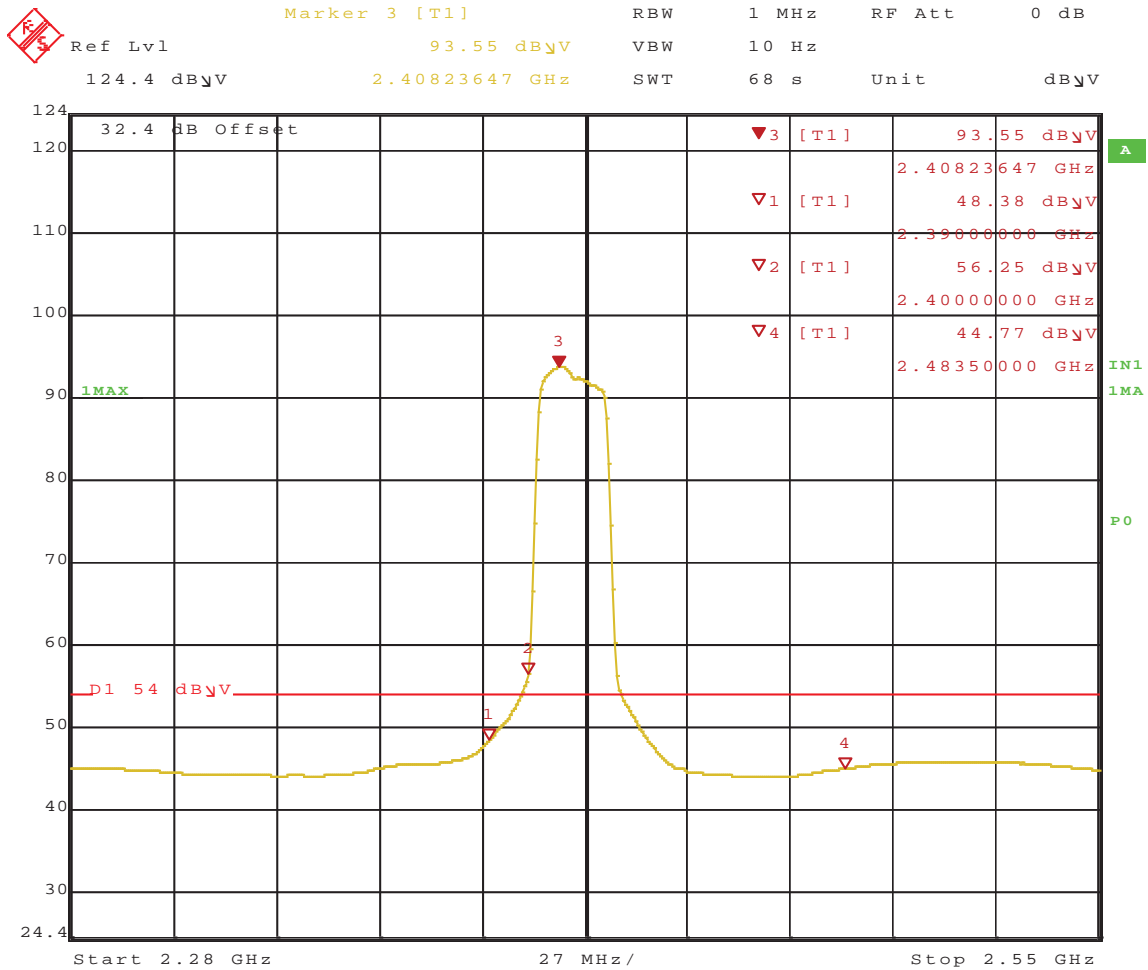

Date: 19.JAN.2011 15:49:19

Figure 316: Radiated Emission at the Edge for Channel 2412MHz at Chain 0 and 1 HT20 13 Mbps – Vertical (Ave.)

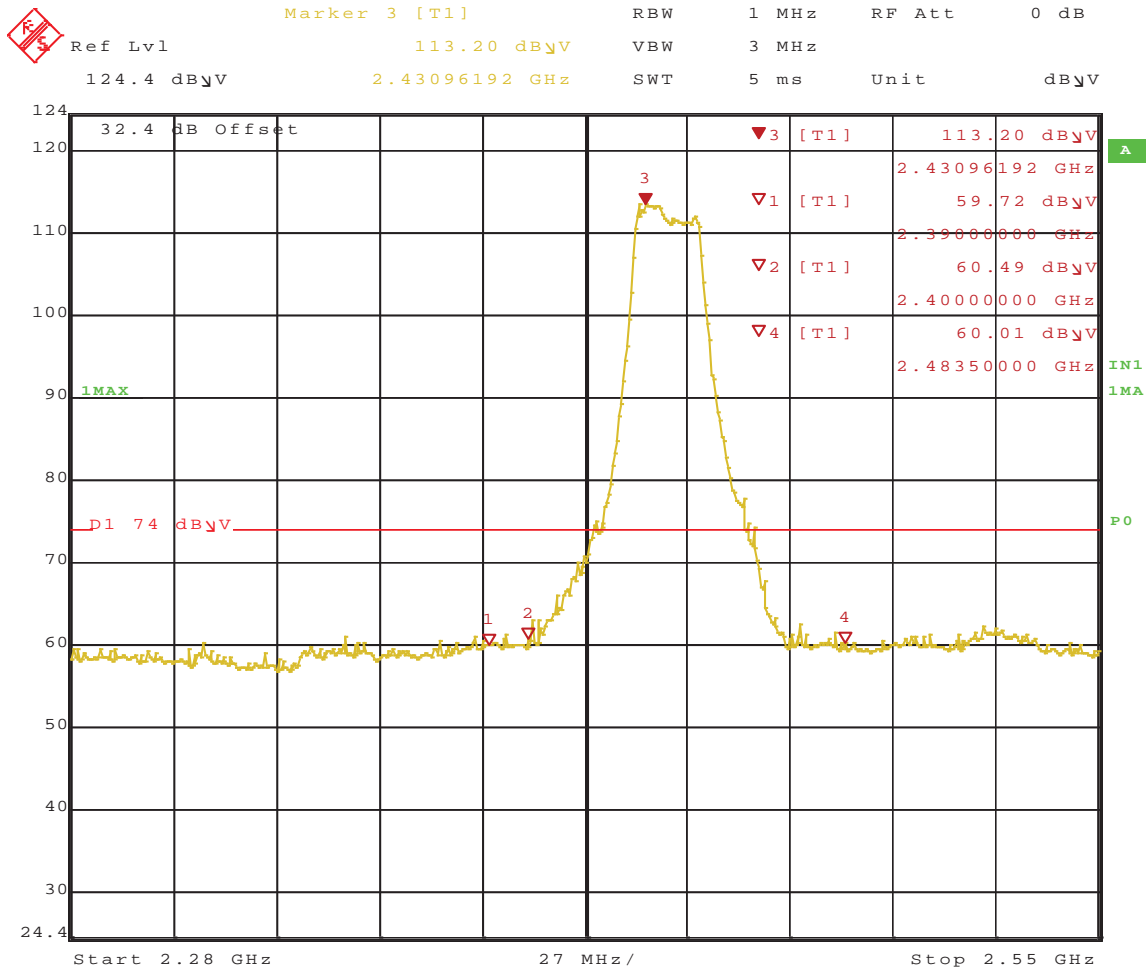

Date: 19.JAN.2011 15:57:45

Figure 317: Radiated Emission at the Edge for Channel 2437MHz at Chain 0 and 1 HT20 13 Mbps – Horizontal (Peak)

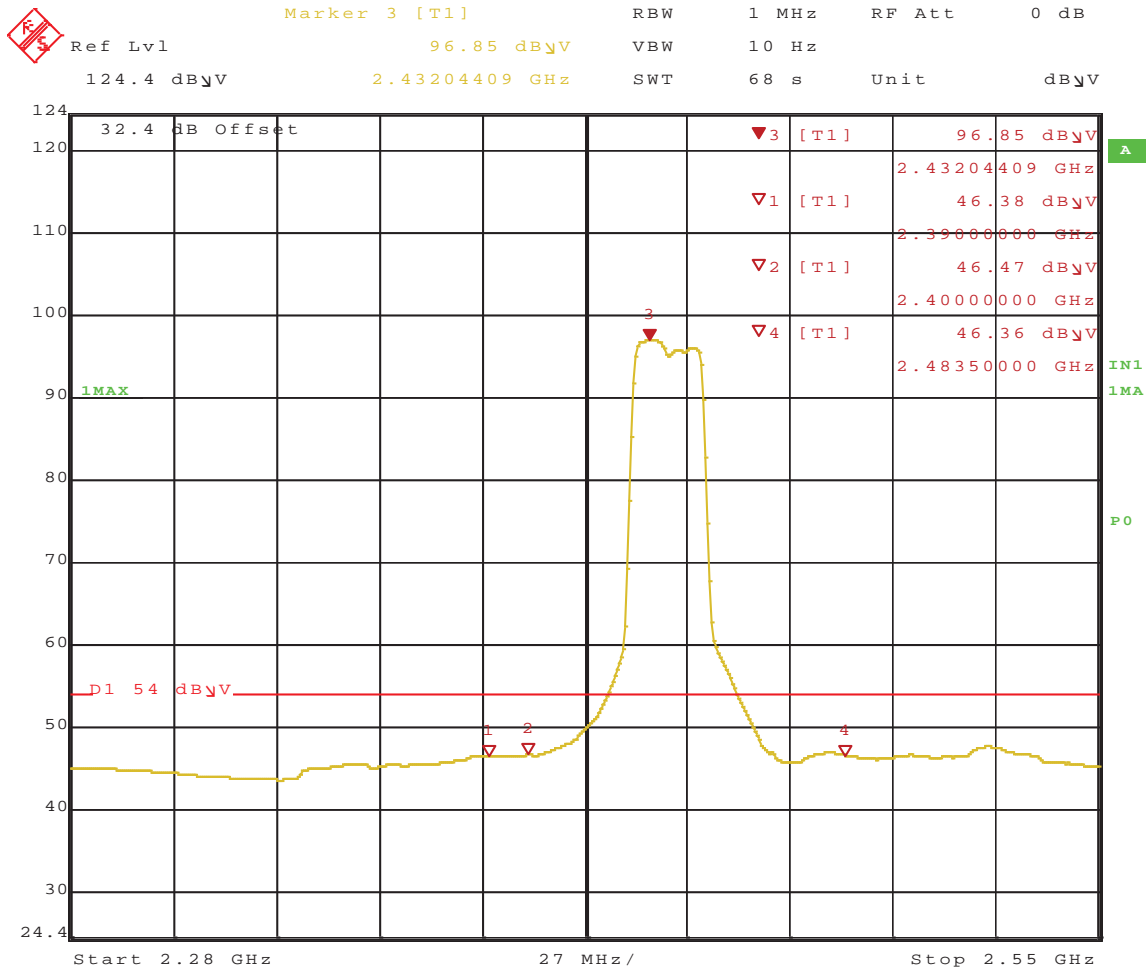

Date: 19.JAN.2011 15:59:22

Figure 318: Radiated Emission at the Edge for Channel 2437MHz at Chain 0 and 1 HT20 13 Mbps – Horizontal (Ave.)

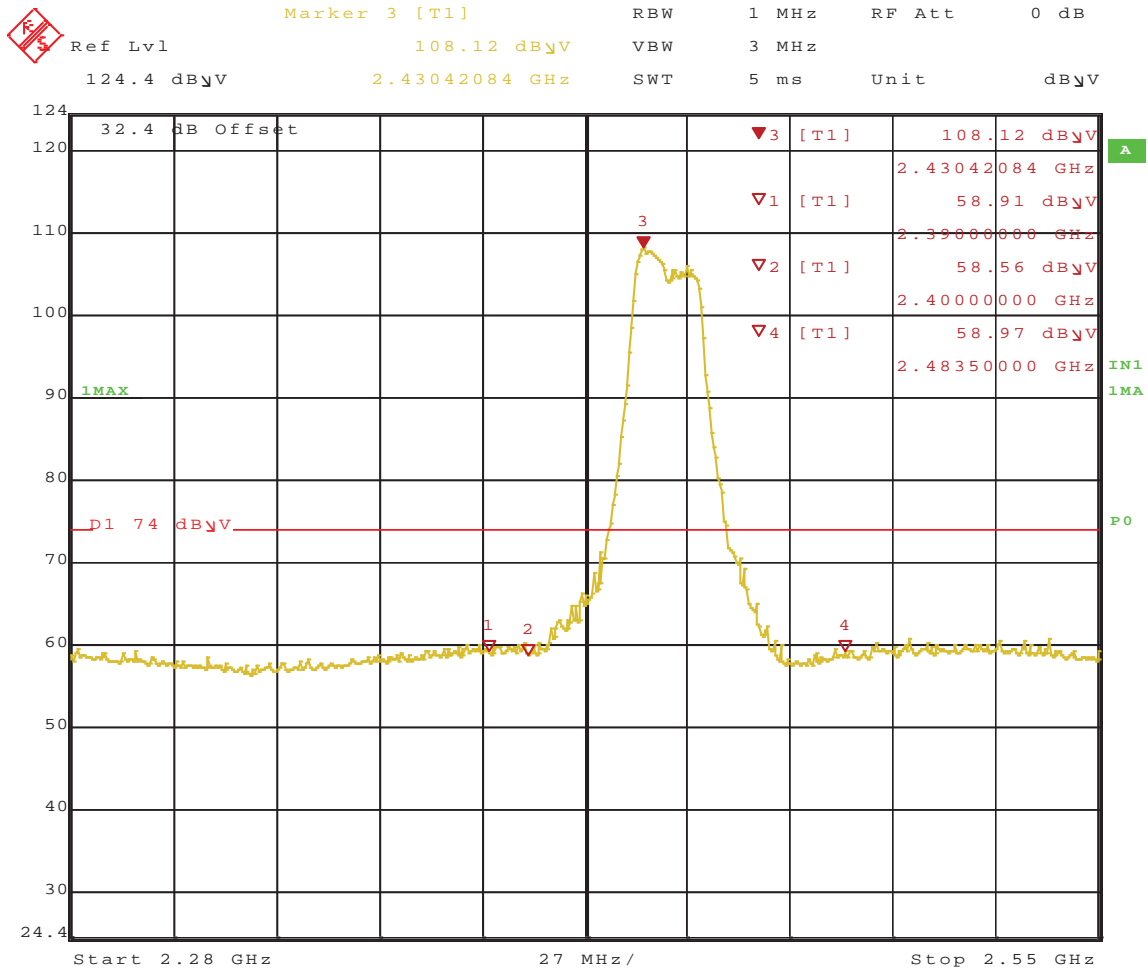

Date: 19.JAN.2011 16:02:18

Figure 319: Radiated Emission at the Edge for Channel 2437MHz at Chain 0 and 1 HT20 13 Mbps – Vertical (Peak)

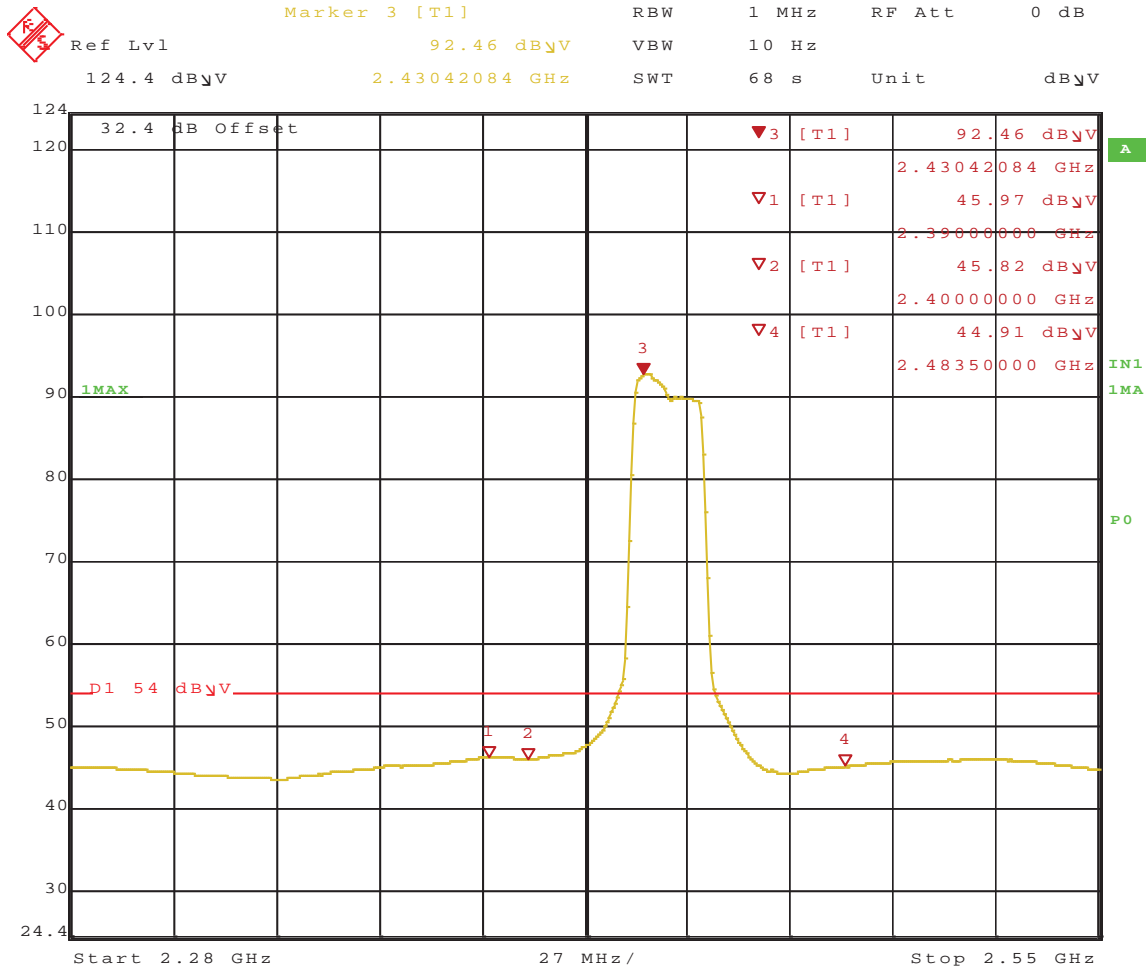

Date: 19.JAN.2011 16:03:55

Figure 320: Radiated Emission at the Edge for Channel 2437MHz at Chain 0 and 1 HT20 13 Mbps – Vertical (Ave.)

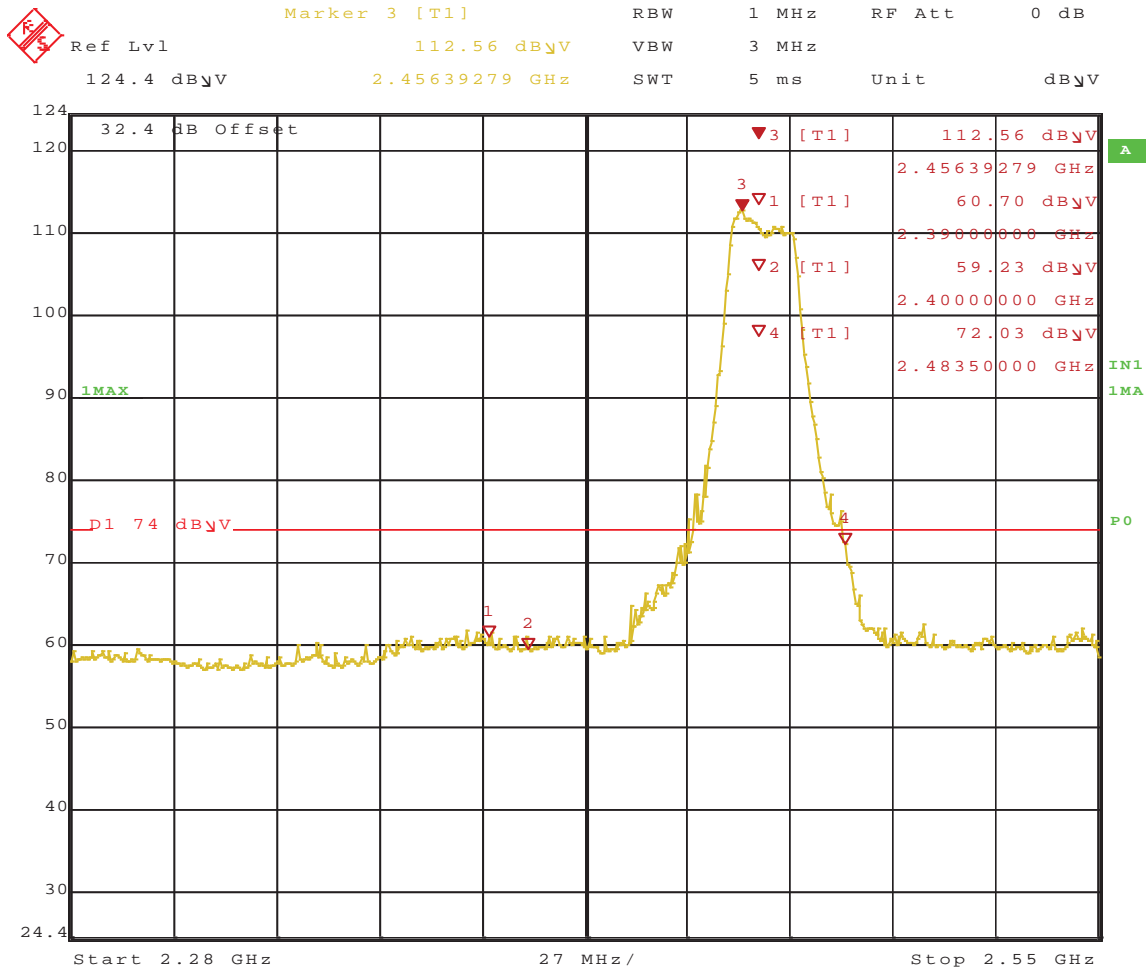

Date: 19.JAN.2011 16:11:09

Figure 321: Radiated Emission at the Edge for Channel 2462MHz at Chain 0 and 1 HT20 13 Mbps – Horizontal (Peak)

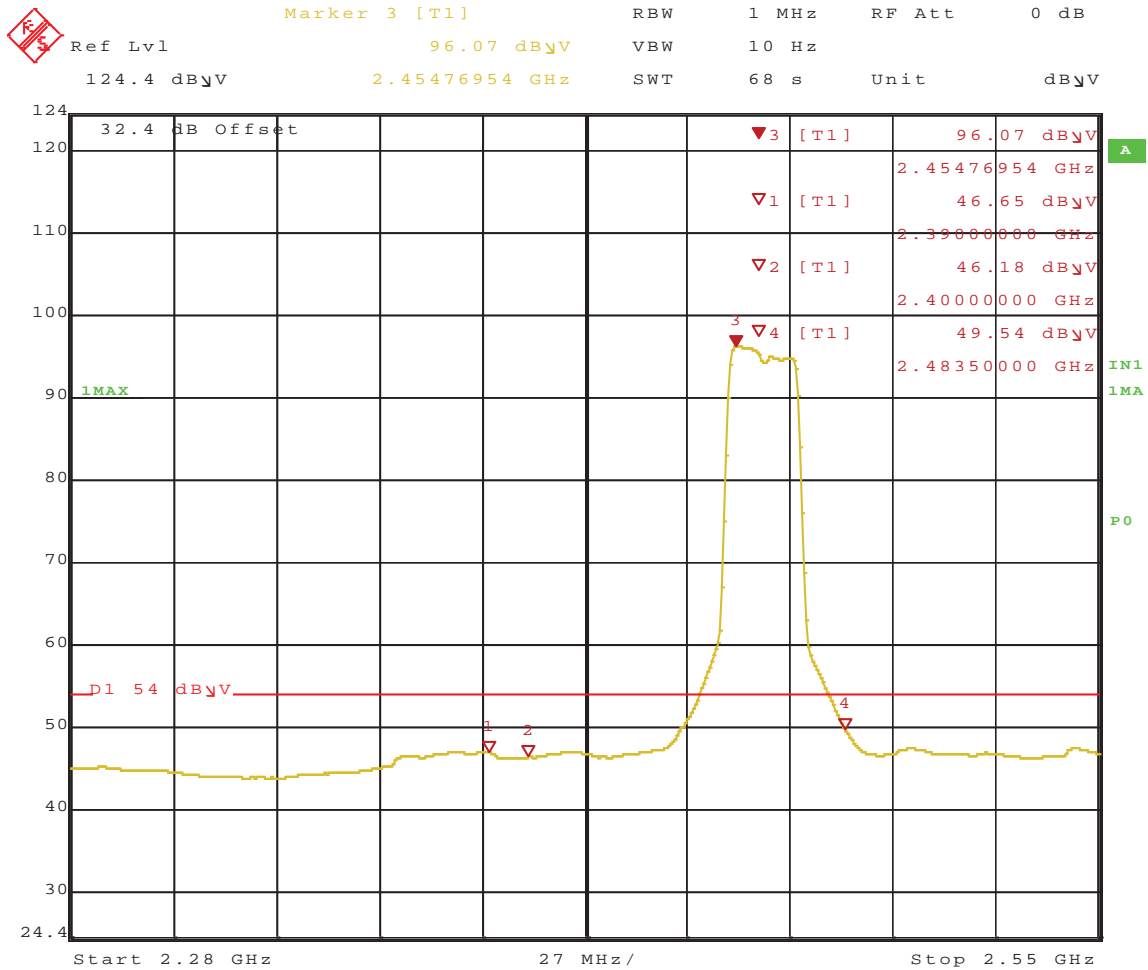

Date: 19.JAN.2011 16:12:48

Figure 322: Radiated Emission at the Edge for Channel 2462MHz at Chain 0 and 1 HT20 13 Mbps – Horizontal (Ave.)

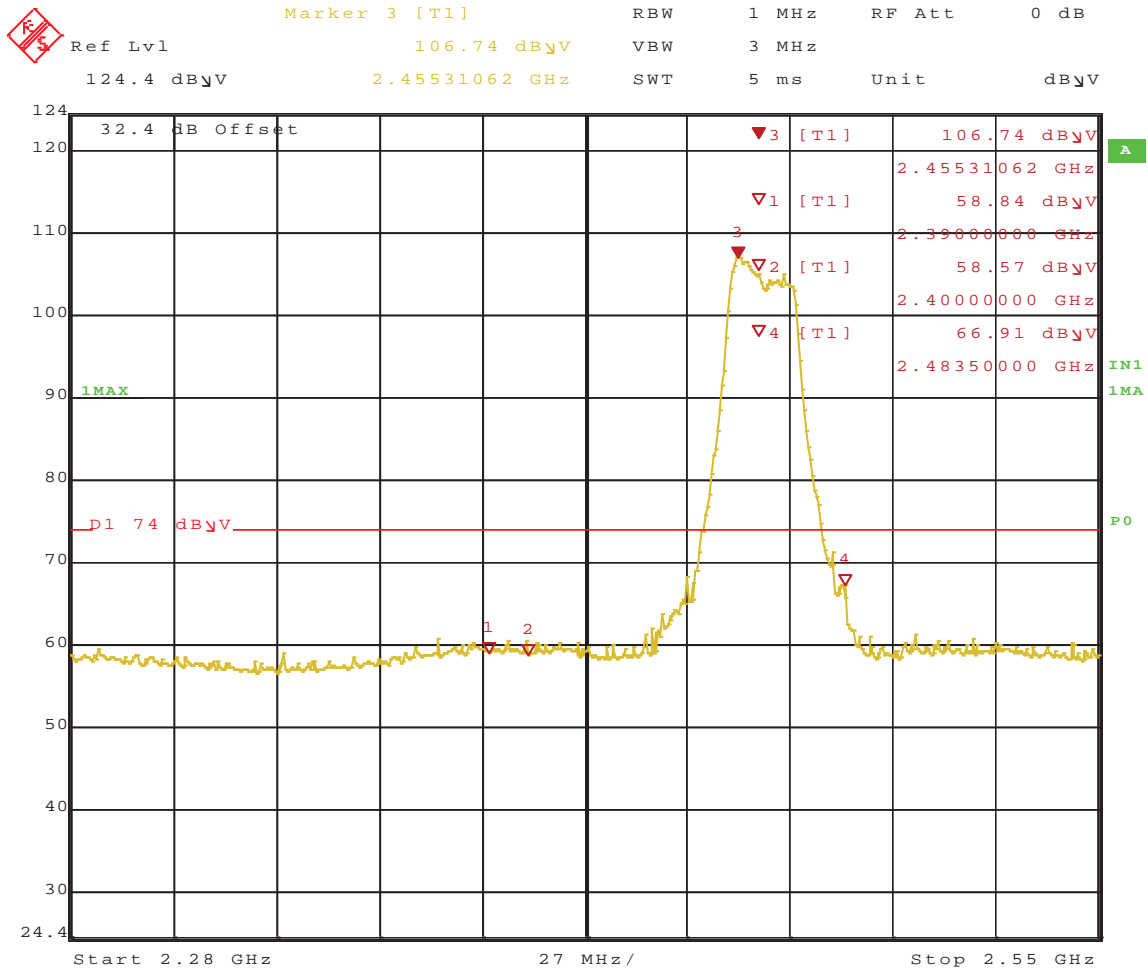

Date: 19.JAN.2011 16:06:48

Figure 323: Radiated Emission at the Edge for Channel 2462MHz at Chain 0 and 1 HT20 13 Mbps – Vertical (Peak)

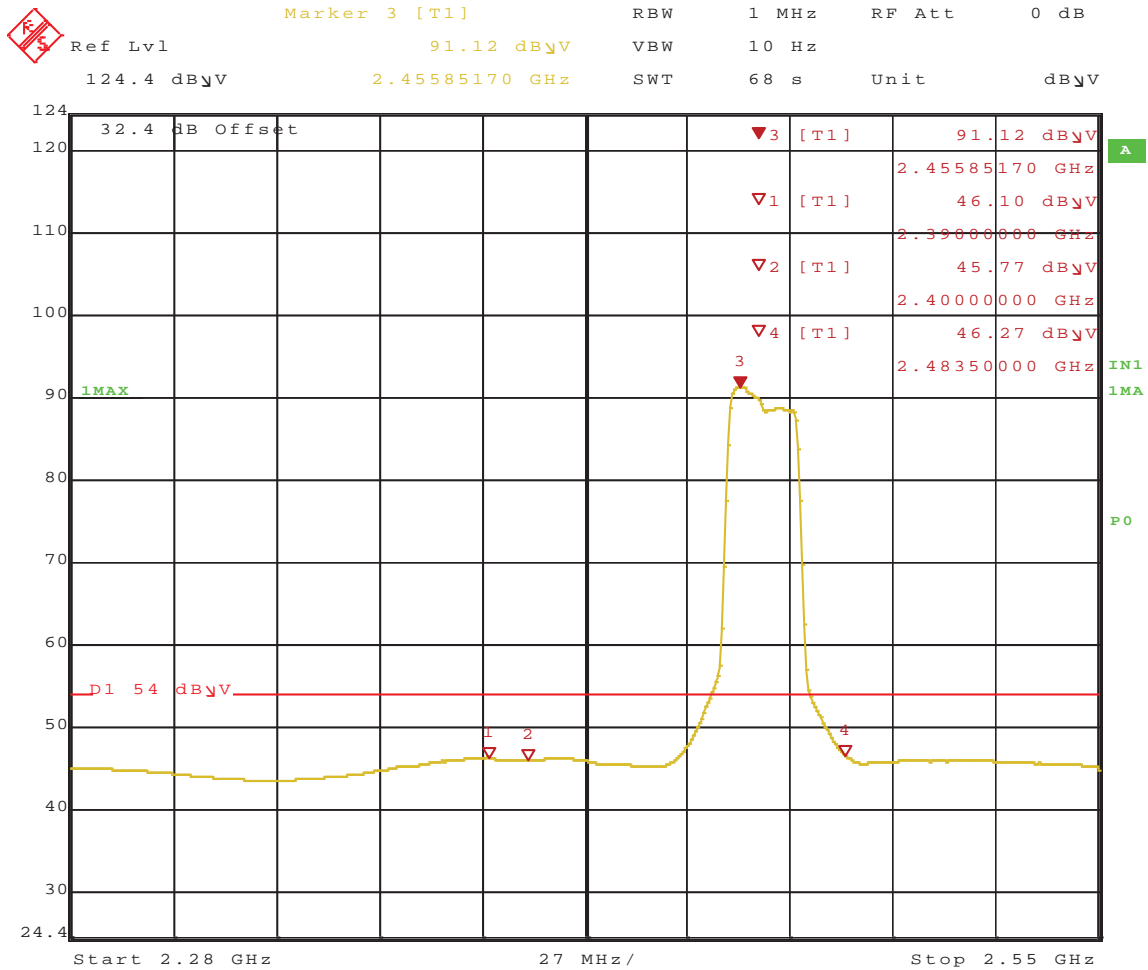

Date: 19.JAN.2011 16:08:27

Figure 324: Radiated Emission at the Edge for Channel 2462MHz at Chain 0 and 1 HT20 13 Mbps – Vertical (Ave.)

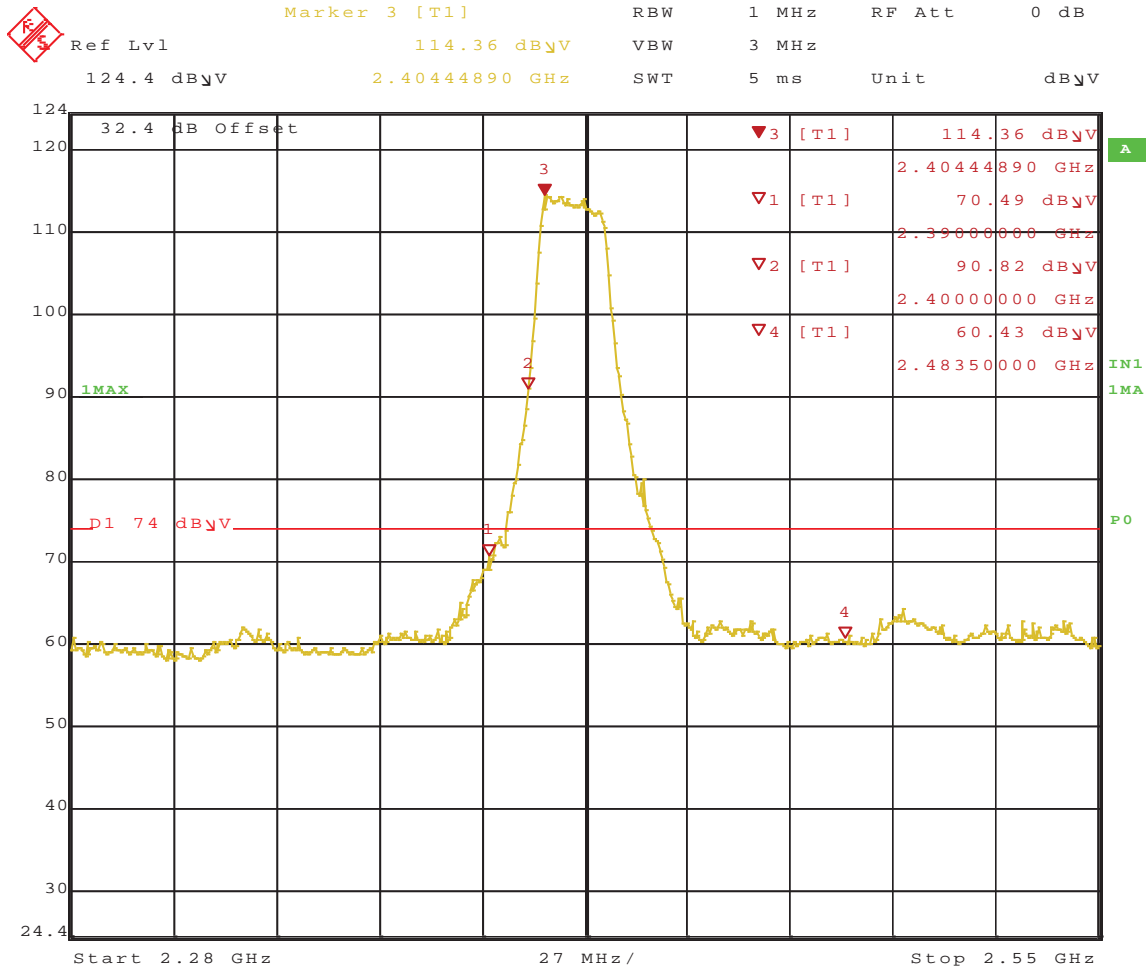

Date: 19.JAN.2011 16:17:07

Figure 325: Radiated Emission at the Edge for Channel 2412MHz at Chain 0, 1, and 2 HT20 39 Mbps – Horizontal (Peak)

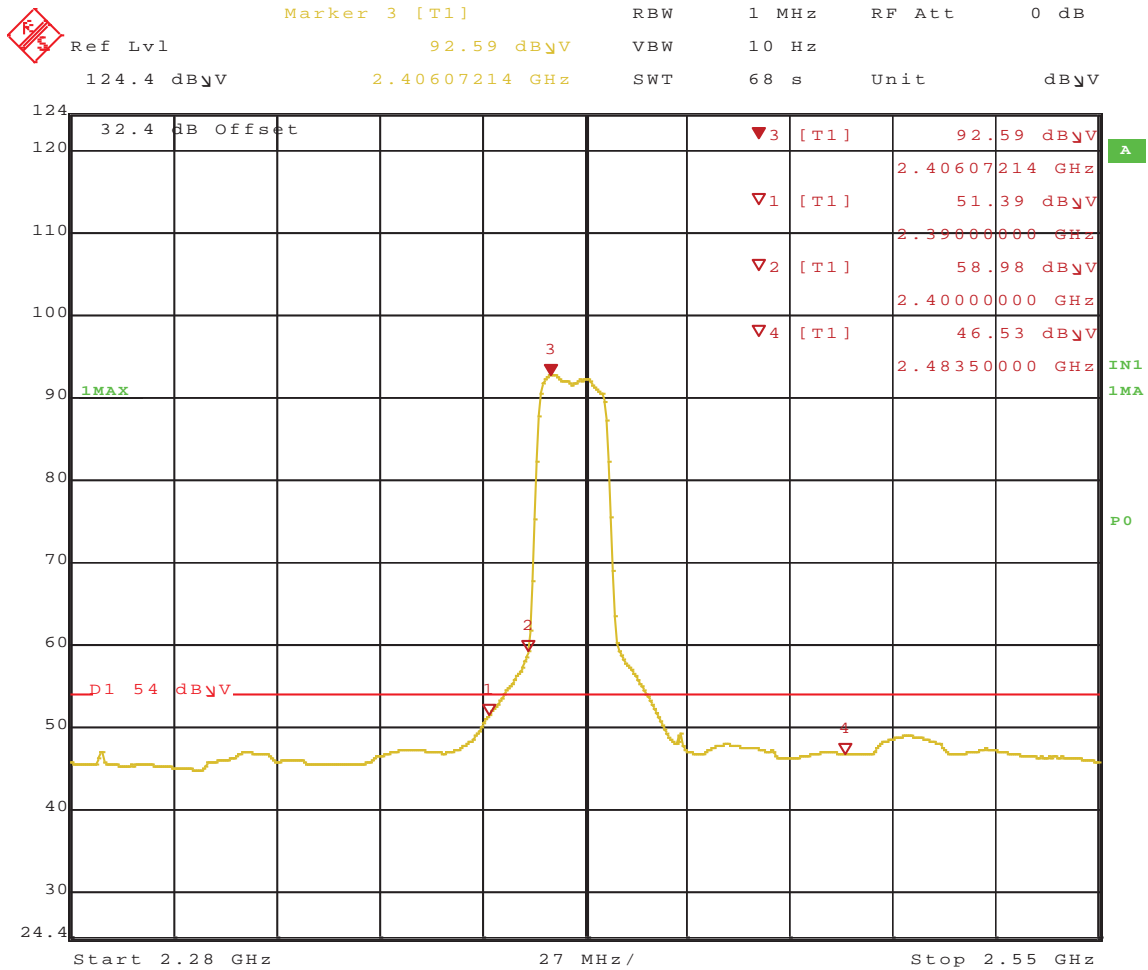

Date: 19.JAN.2011 16:19:06

Figure 326: Radiated Emission at the Edge for Channel 2412MHz at Chain 0, 1, and 2 HT20 39 Mbps – Horizontal (Ave.)

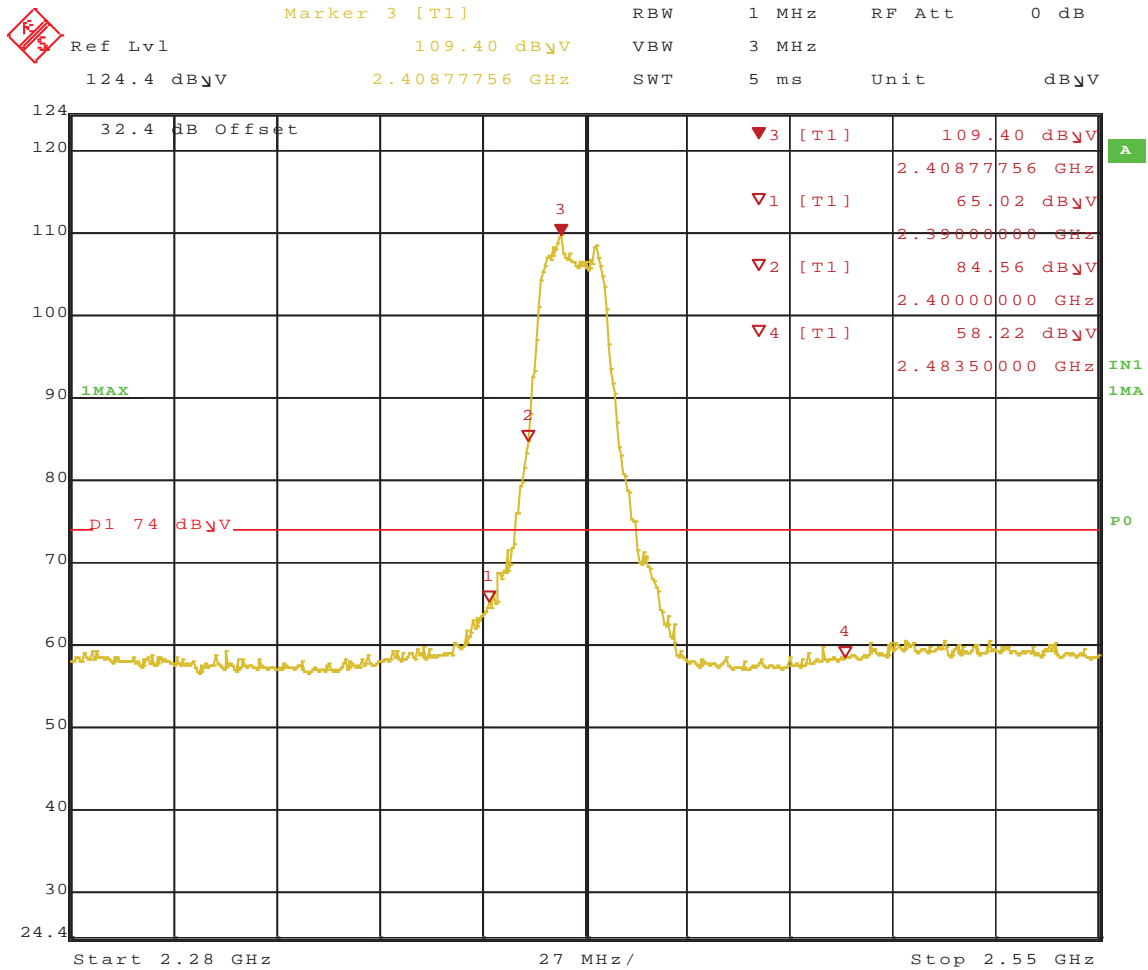

Date: 19.JAN.2011 16:21:33

Figure 327: Radiated Emission at the Edge for Channel 2412MHz at Chain 0, 1, and 2 HT20 39 Mbps – Vertical (Peak)

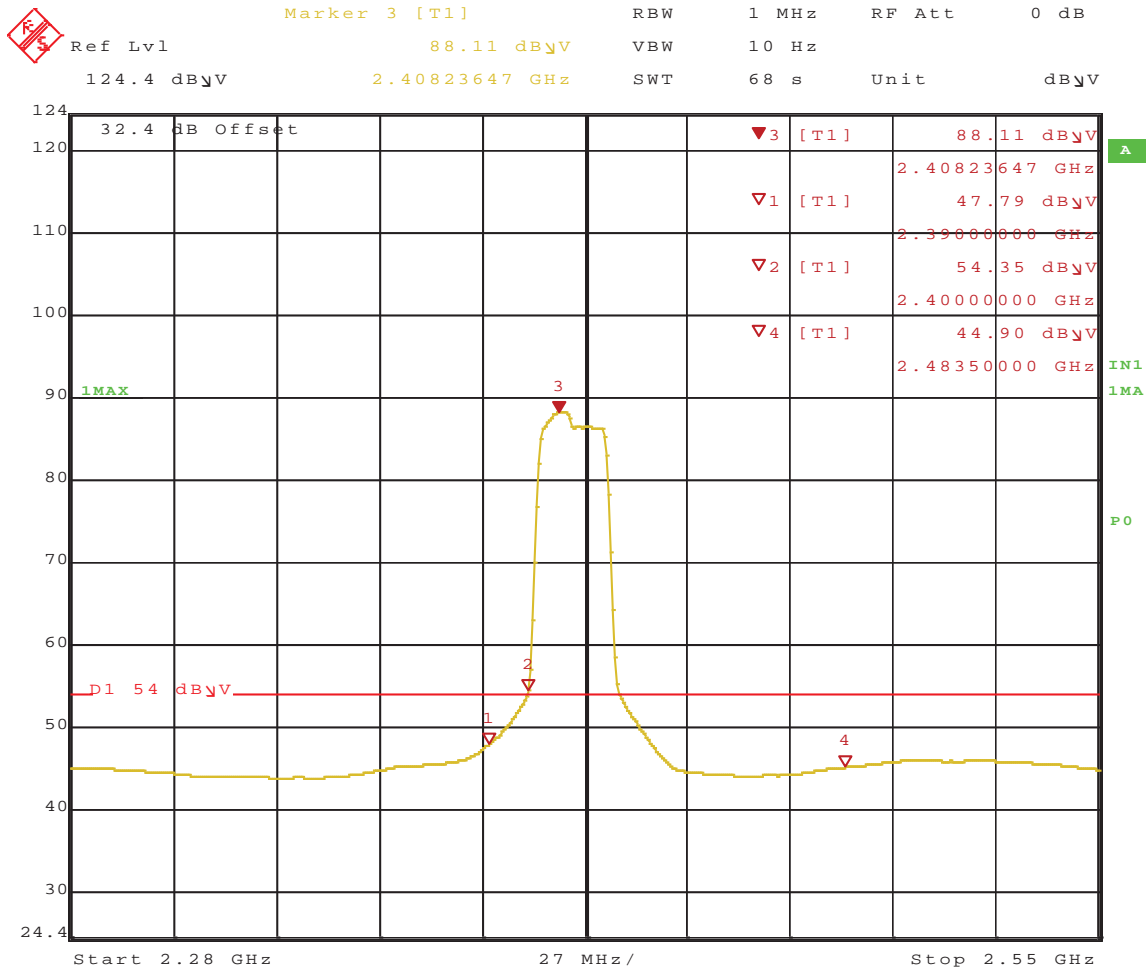

Date: 19.JAN.2011 16:23:04

Figure 328: Radiated Emission at the Edge for Channel 2412MHz at Chain 0, 1, and 2 HT20 39 Mbps – Vertical (Ave.)

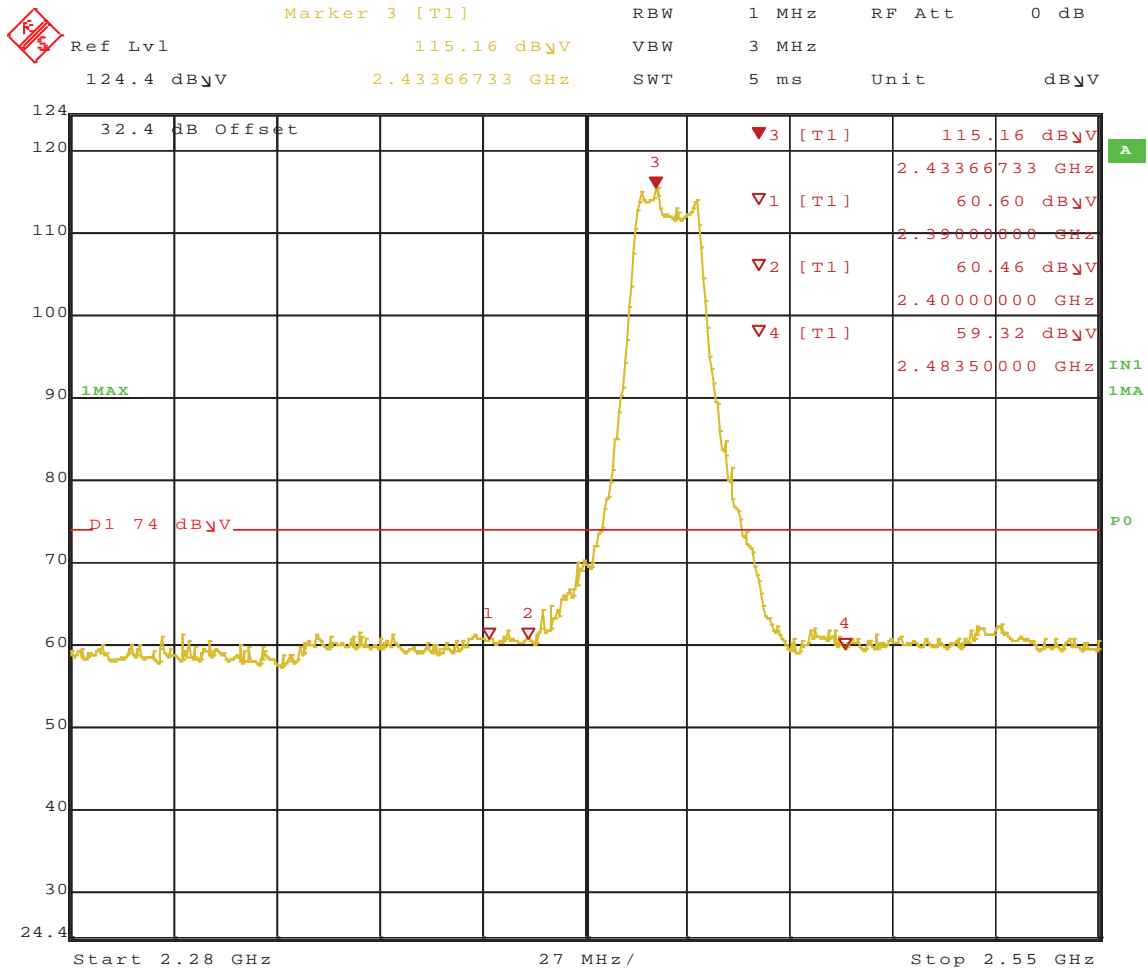

Date: 19.JAN.2011 16:29:06

Figure 329: Radiated Emission at the Edge for Channel 2437MHz at Chain 0, 1, and 2 HT20 39 Mbps – Horizontal (Peak)

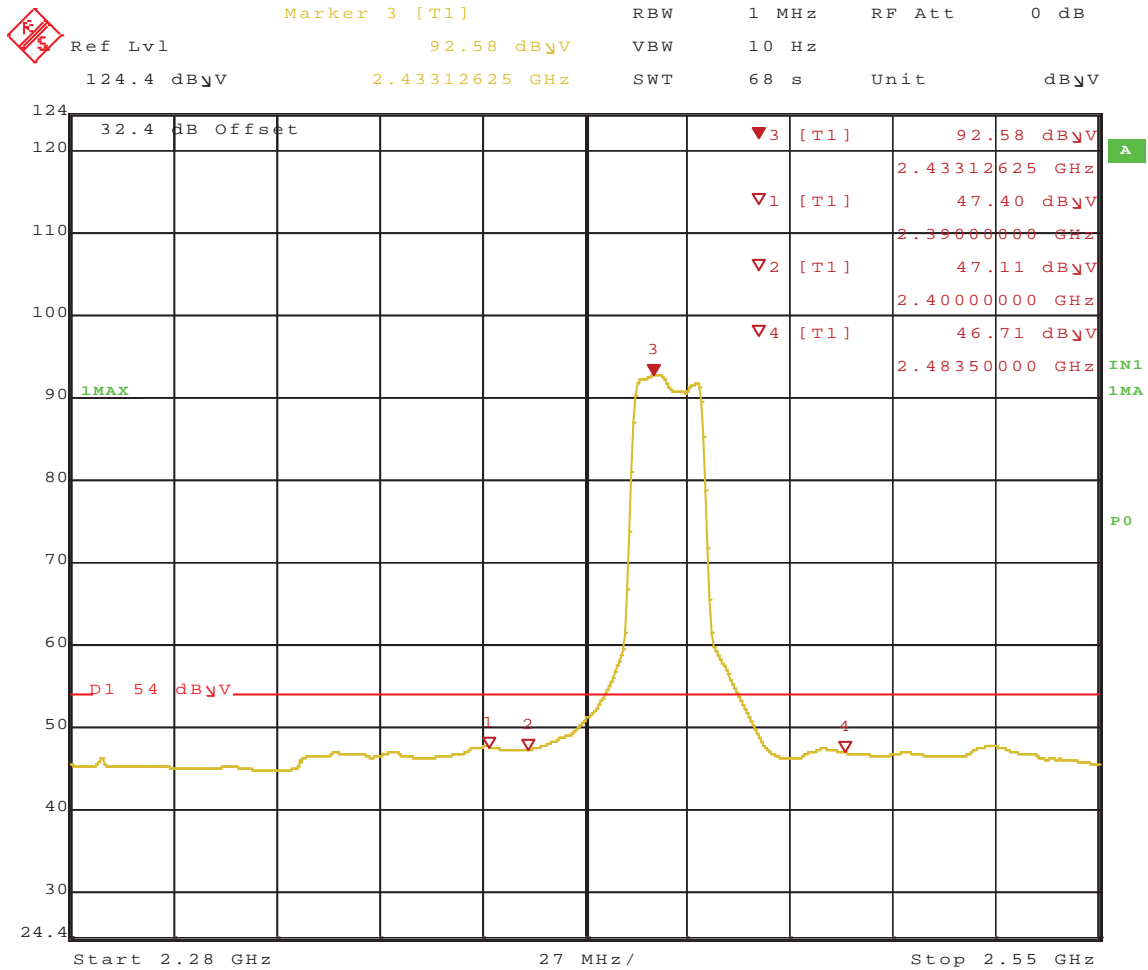

Date: 19.JAN.2011 16:30:43

Figure 330: Radiated Emission at the Edge for Channel 2437MHz at Chain 0, 1, and 2 HT20 39 Mbps – Horizontal (Ave.)

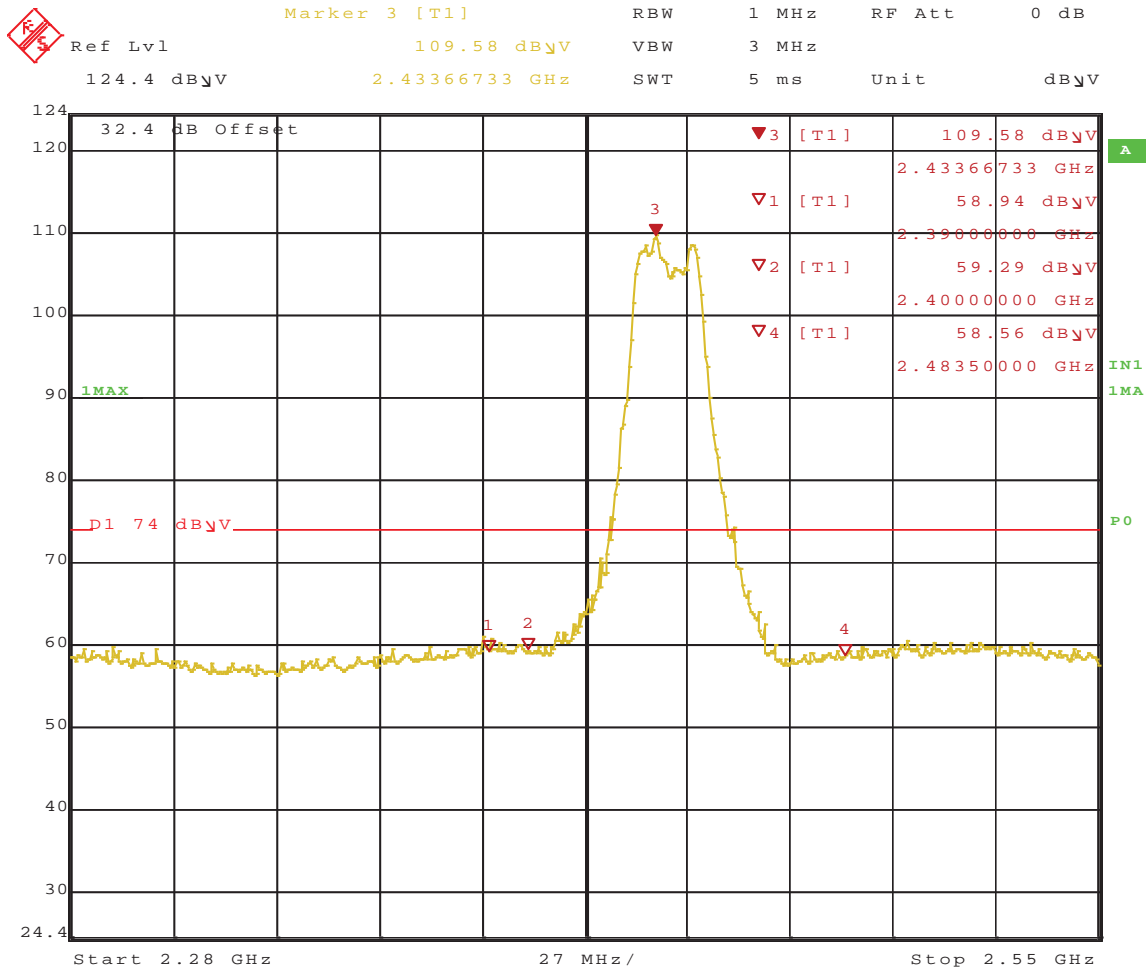

Date: 19.JAN.2011 16:25:20

Figure 331: Radiated Emission at the Edge for Channel 2437MHz at Chain 0, 1, and 2 HT20 39 Mbps – Vertical (Peak)

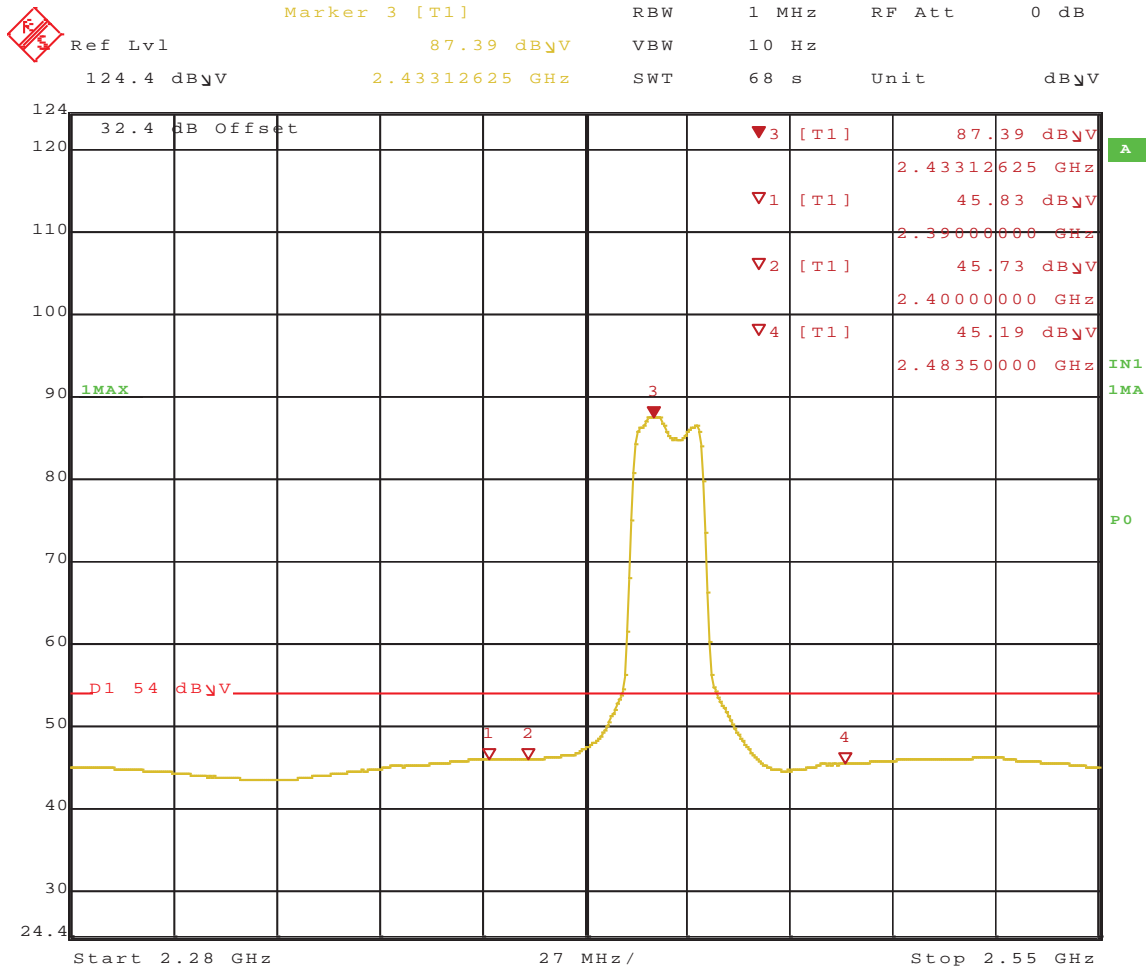

Date: 19.JAN.2011 16:26:58

Figure 332: Radiated Emission at the Edge for Channel 2437MHz at Chain 0, 1, and 2 HT20 39 Mbps – Vertical (Ave.)

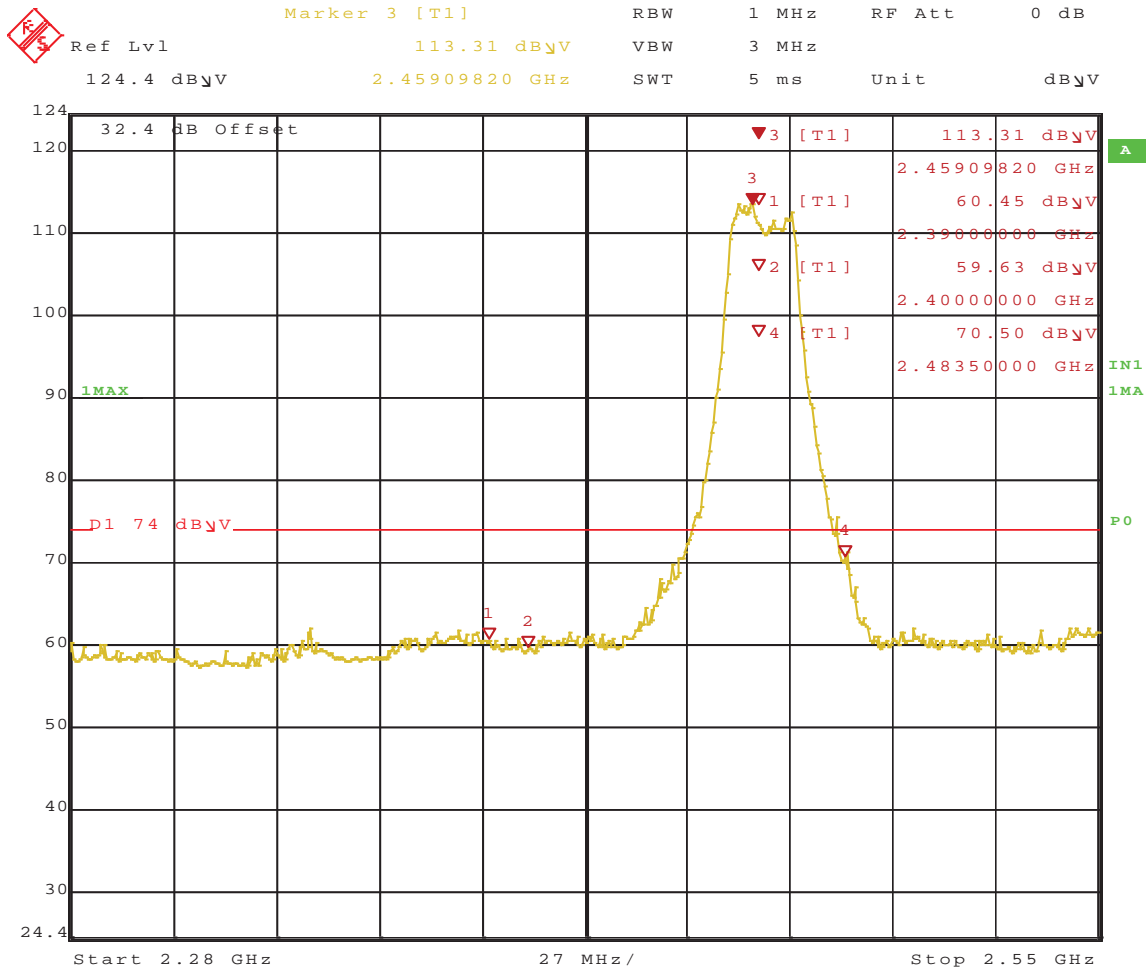

Date: 19.JAN.2011 16:33:24

Figure 333: Radiated Emission at the Edge for Channel 2462MHz at Chain 0, 1, and 2 HT20 39 Mbps – Horizontal (Peak)

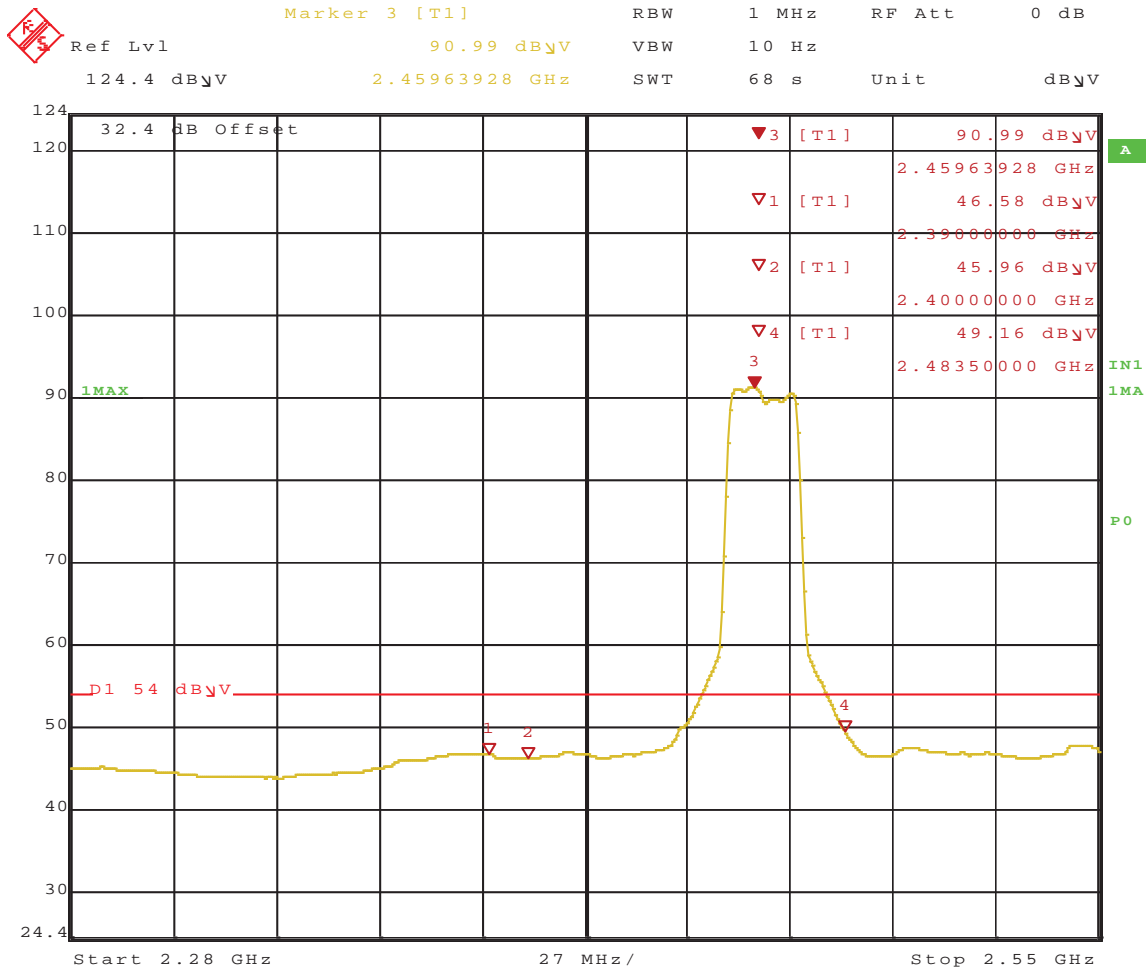

Date: 19.JAN.2011 16:35:08

Figure 334: Radiated Emission at the Edge for Channel 2462MHz at Chain 0, 1, and 2 HT20 39 Mbps – Horizontal (Ave.)

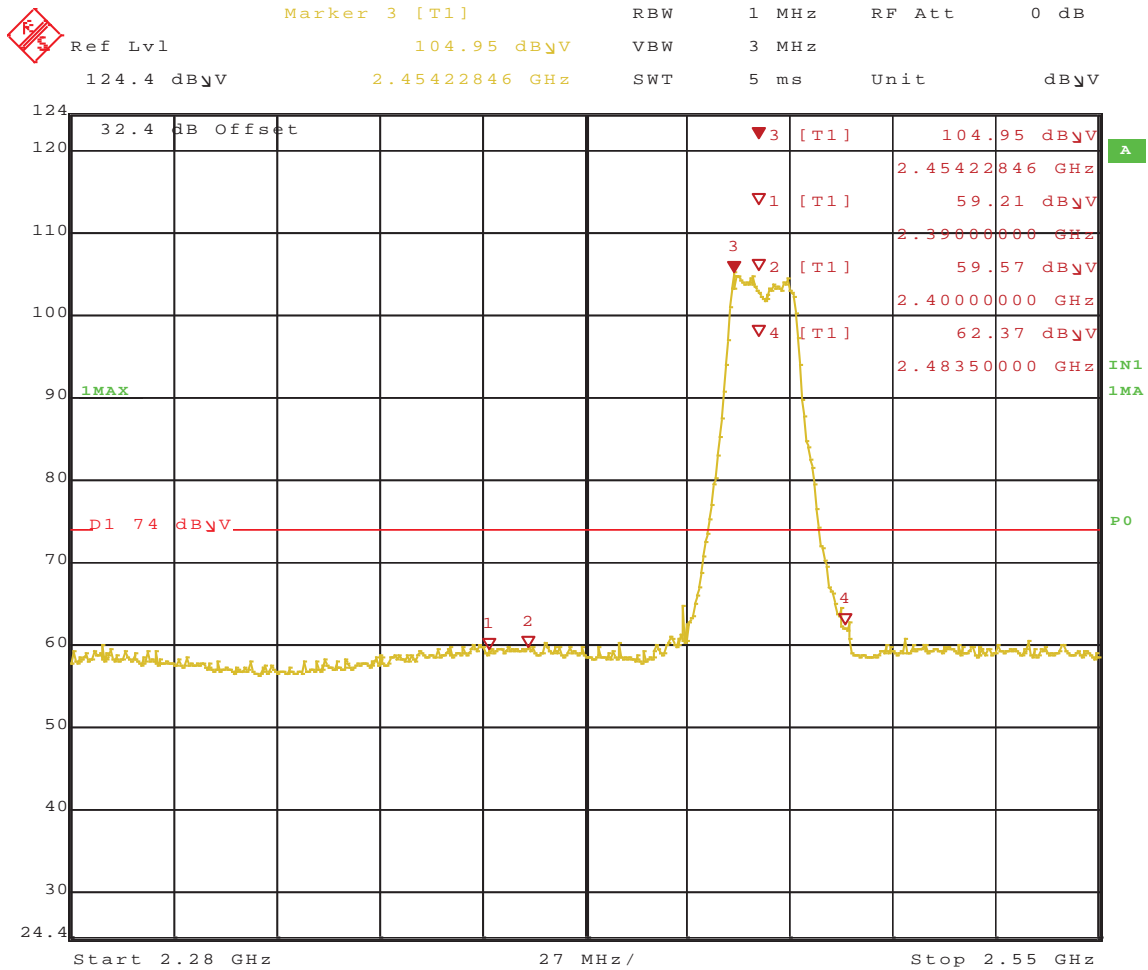

Date: 19.JAN.2011 16:37:34

Figure 335: Radiated Emission at the Edge for Channel 2462MHz at Chain 0, 1, and 2 HT20 39 Mbps – Vertical (Peak)

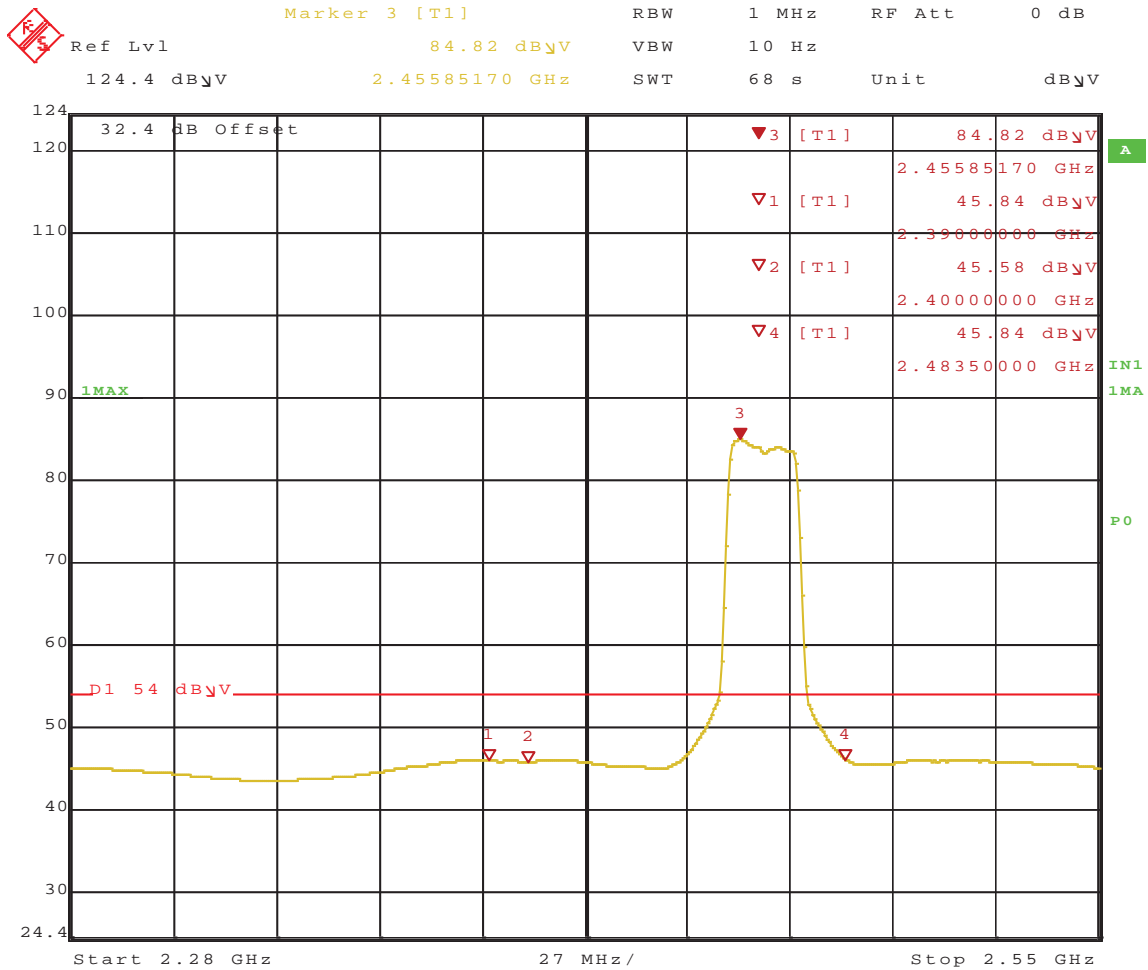

Date: 19.JAN.2011 16:39:21

Figure 336: Radiated Emission at the Edge for Channel 2462MHz at Chain 0, 1, and 2 HT20 39 Mbps – Vertical (Ave.)

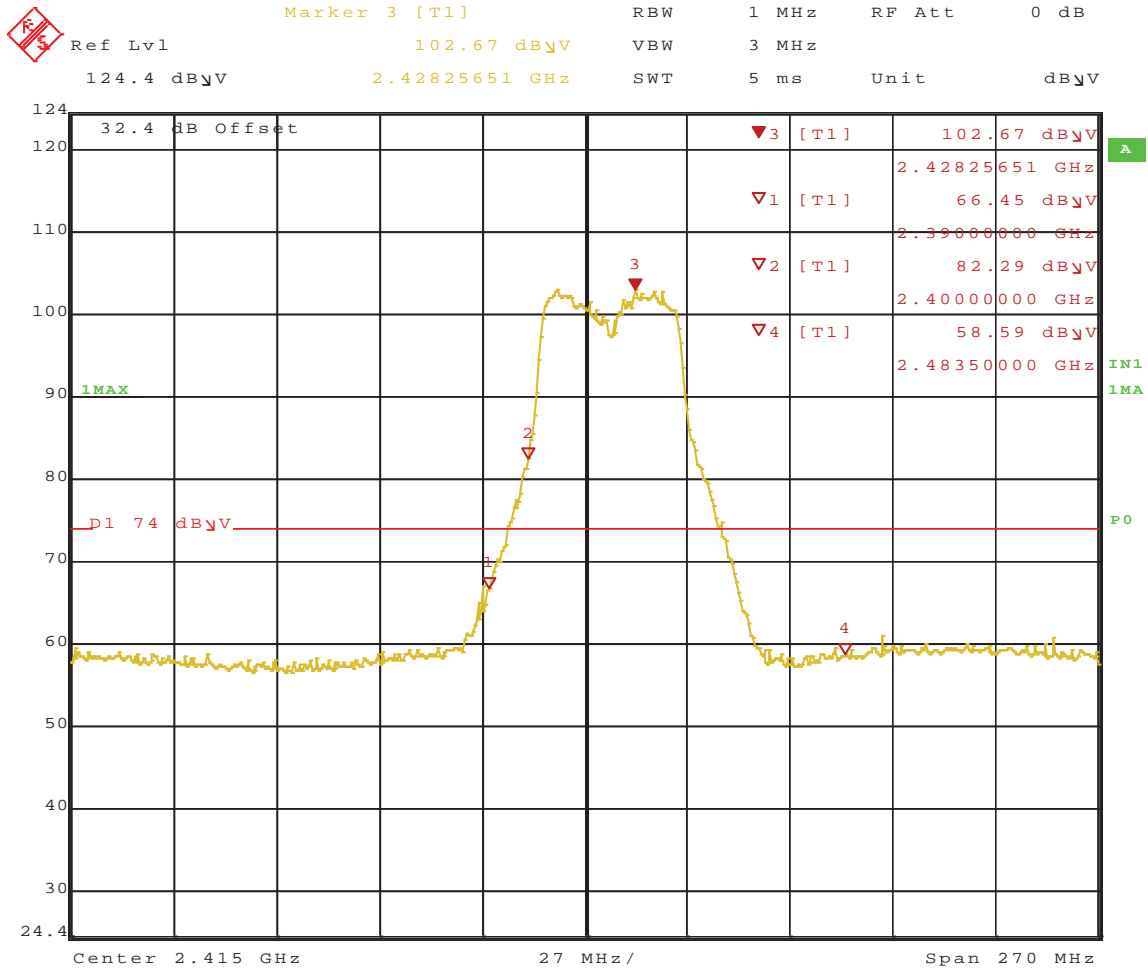

Date: 20.JAN.2011 08:34:56

Figure 337: Radiated Emission at the Edge for Channel 2422MHz at Chain 1 HT40 40.5 Mbps – Horizontal (Peak)

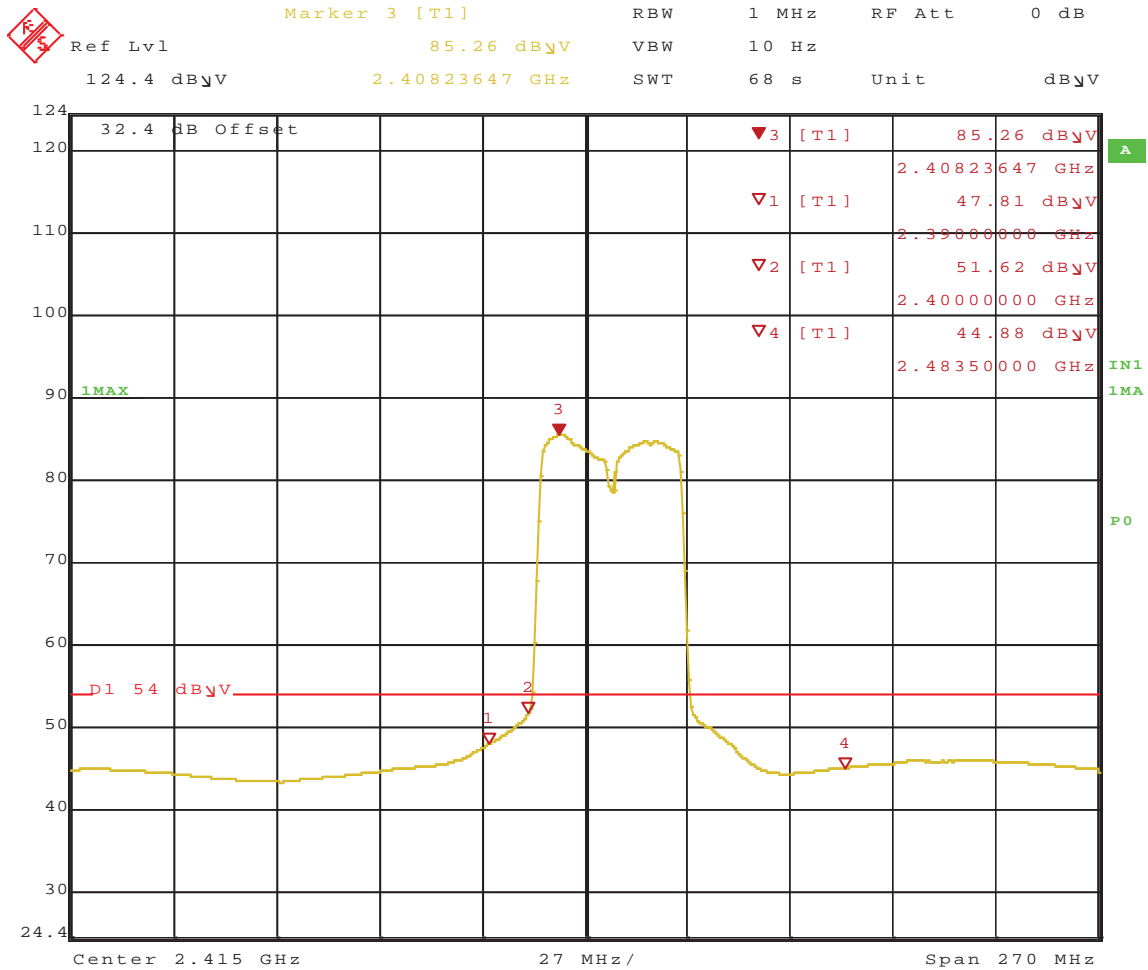

Date: 20.JAN.2011 08:37:04

Figure 338: Radiated Emission at the Edge for Channel 2422MHz Chain 1 HT40 40.5 Mbps – Horizontal (Ave.)

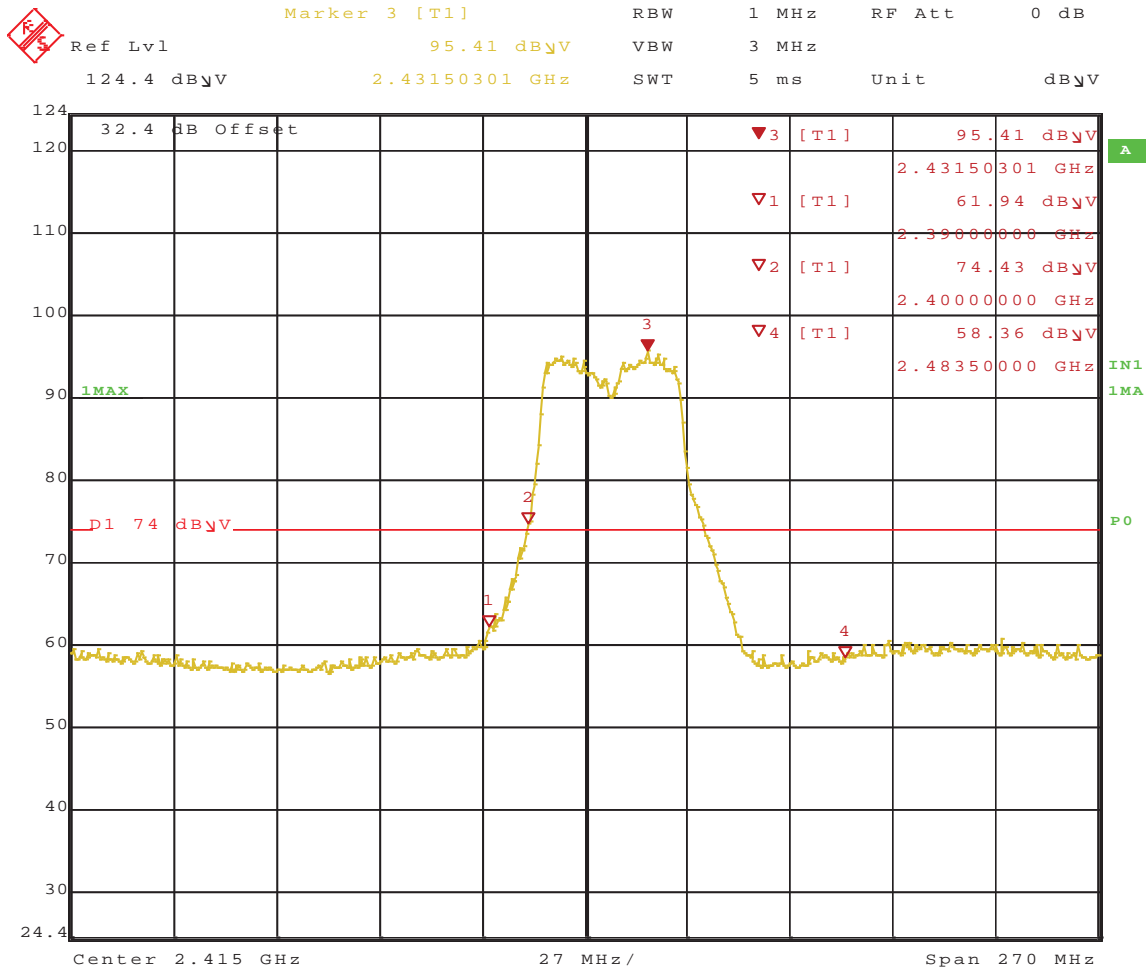

Date: 20.JAN.2011 08:28:35

Figure 339: Radiated Emission at the Edge for Channel 2422MHz at Chain 1 HT40 40.5 Mbps – Vertical (Peak)

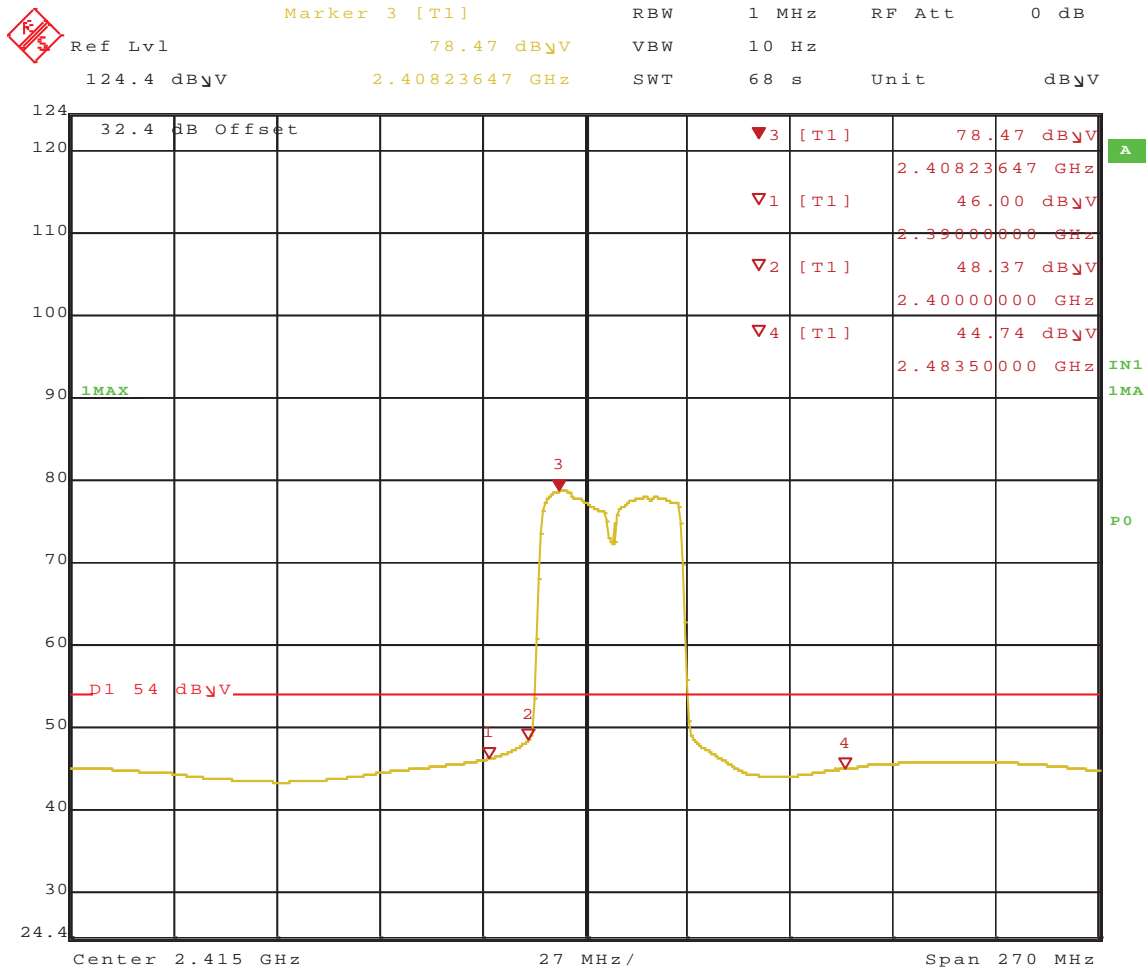

Date: 20.JAN.2011 08:31:54

Figure 340: Radiated Emission at the Edge for Channel 2422MHz at Chain 1 HT40 40.5 Mbps – Vertical (Ave.)

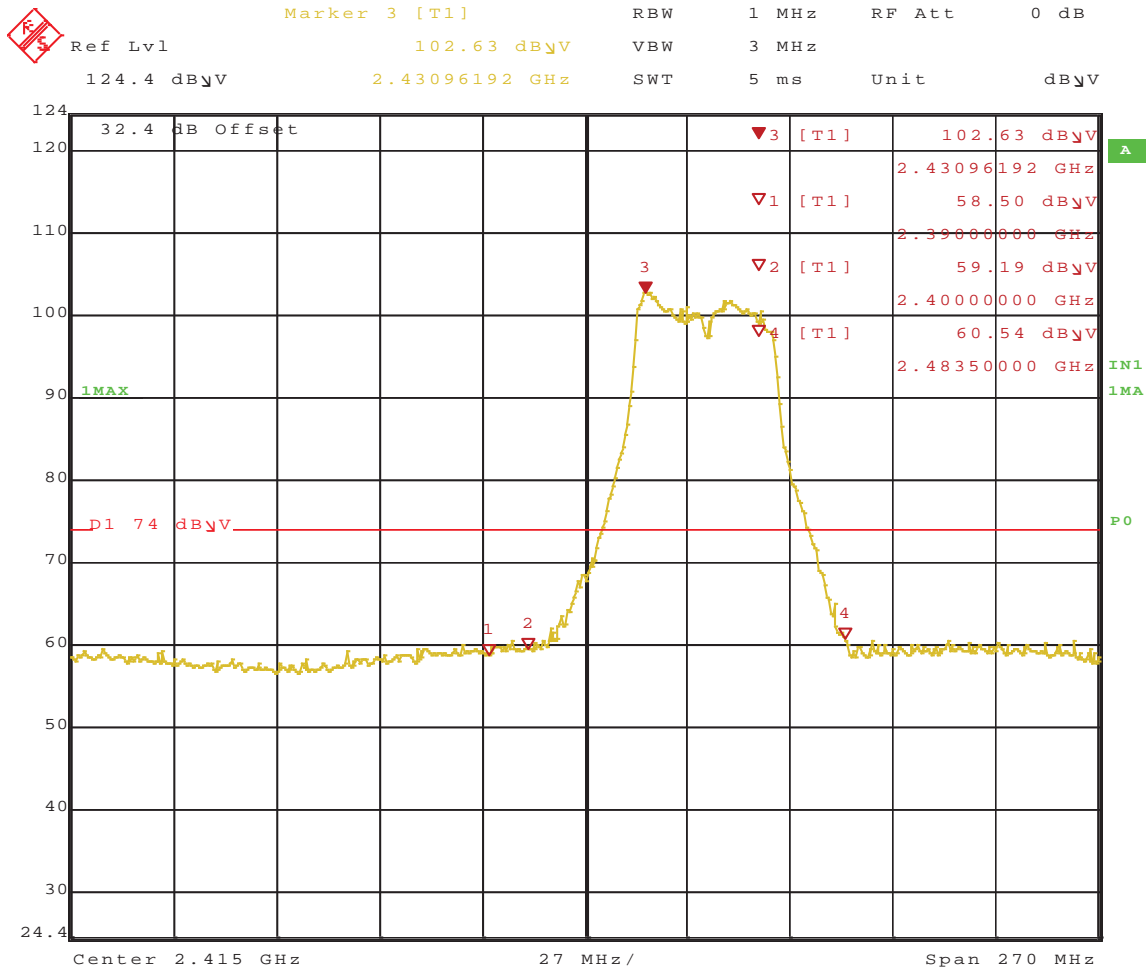

Date: 20.JAN.2011 08:41:33

Figure 341: Radiated Emission at the Edge for Channel 2437MHz at Chain 1 HT40 40.5 Mbps – Horizontal (Peak)

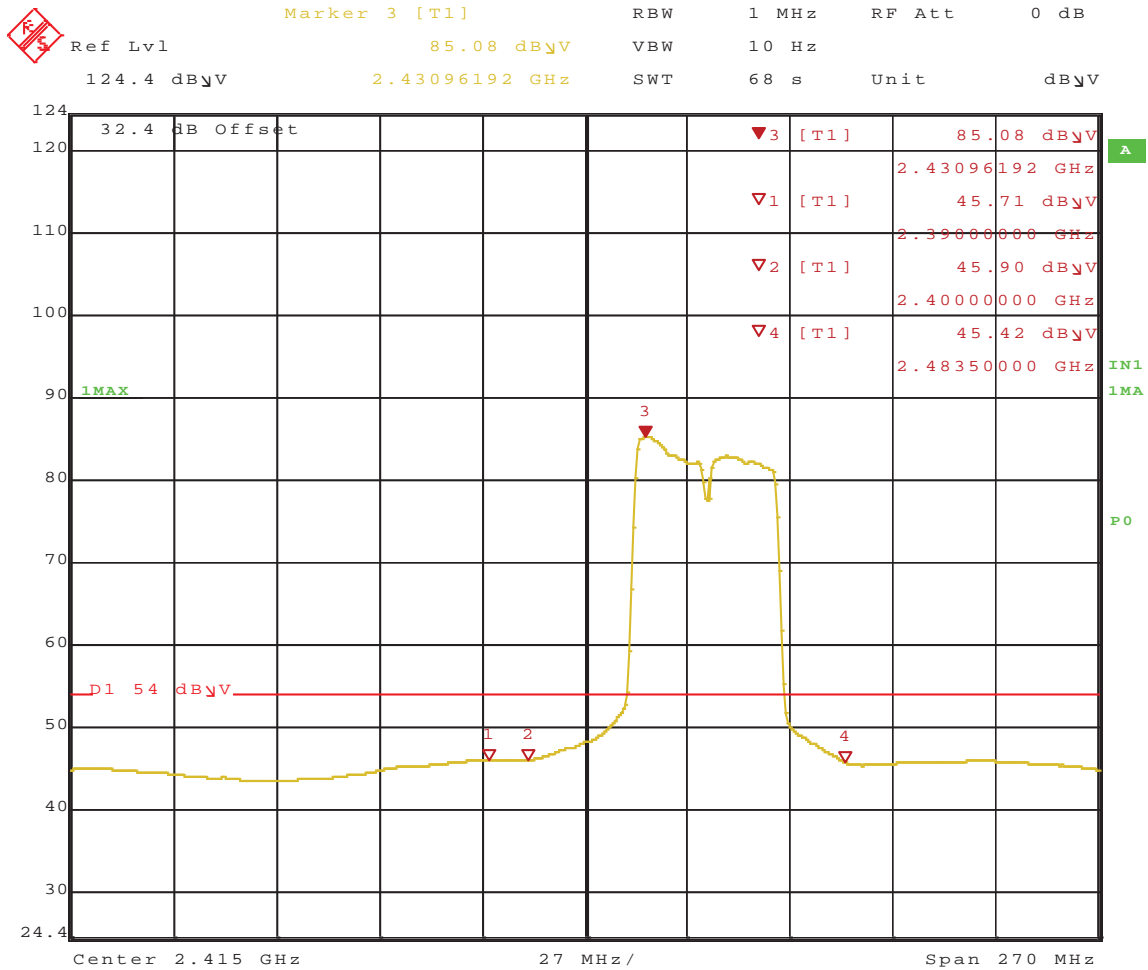

Date: 20.JAN.2011 08:43:53

Figure 342: Radiated Emission at the Edge for Channel 2437MHz at Chain 1 HT40 40.5 Mbps – Horizontal (Ave.)

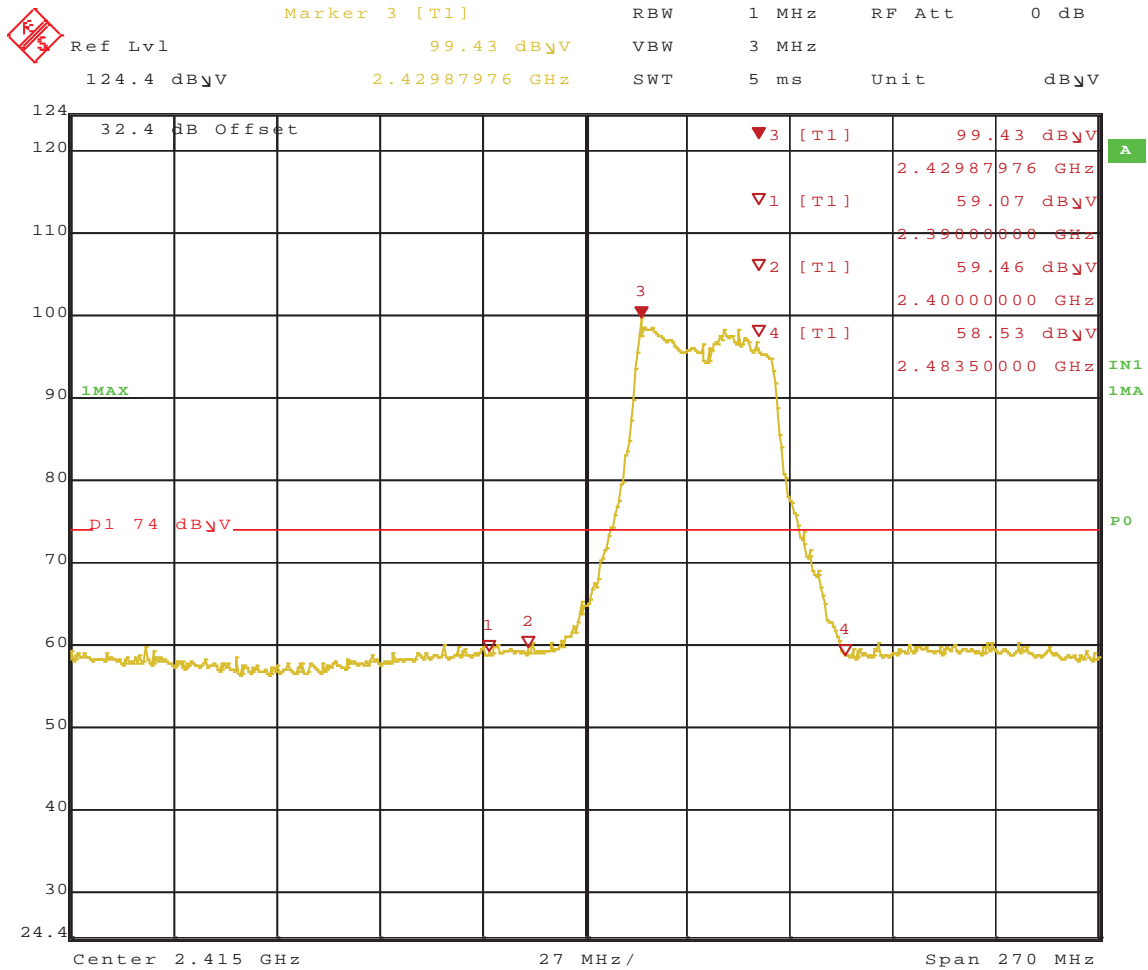

Date: 20.JAN.2011 08:46:46

Figure 343: Radiated Emission at the Edge for Channel 2437MHz at Chain 1 HT40 40.5 Mbps – Vertical (Peak)

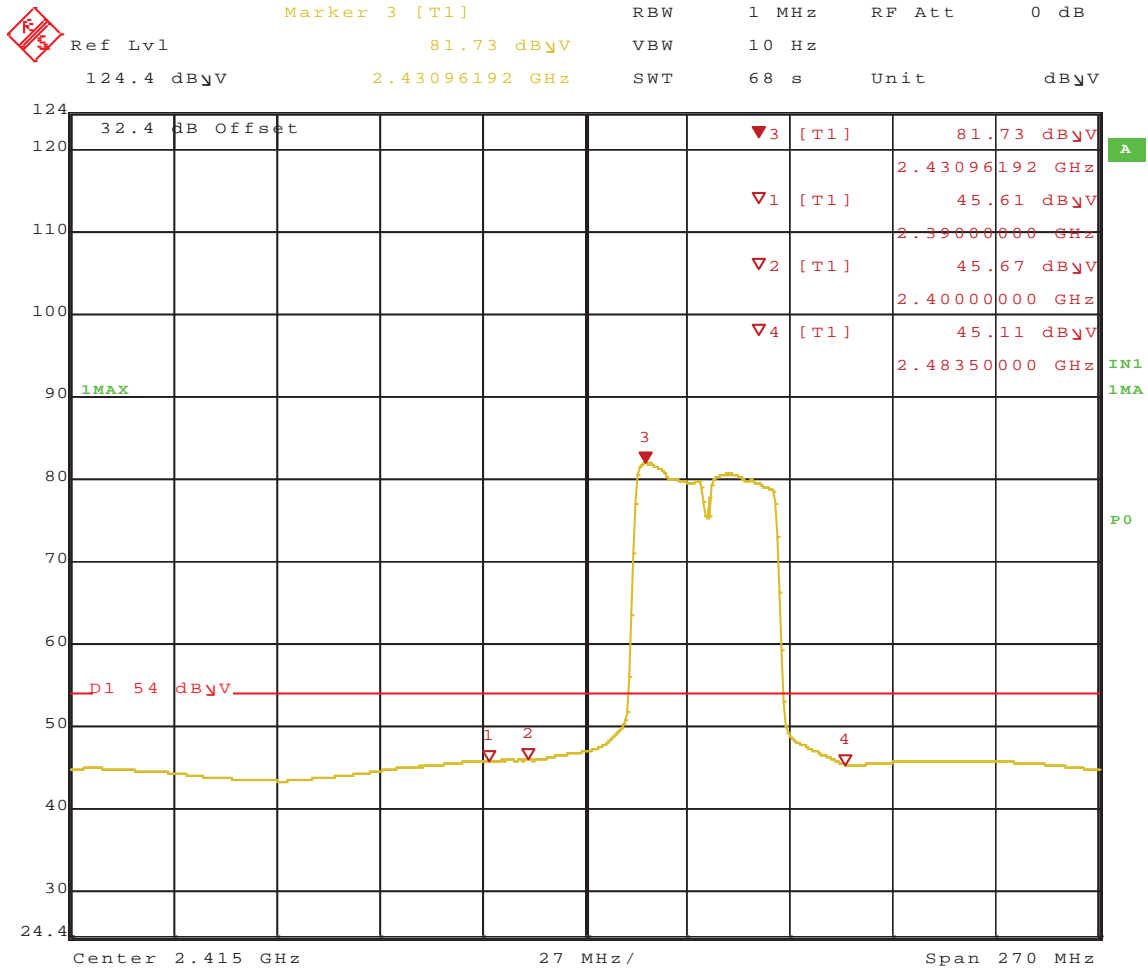

Date: 20.JAN.2011 08:48:45

Figure 344: Radiated Emission at the Edge for Channel 2437MHz at Chain 1 HT40 40.5 Mbps – Vertical (Ave.)

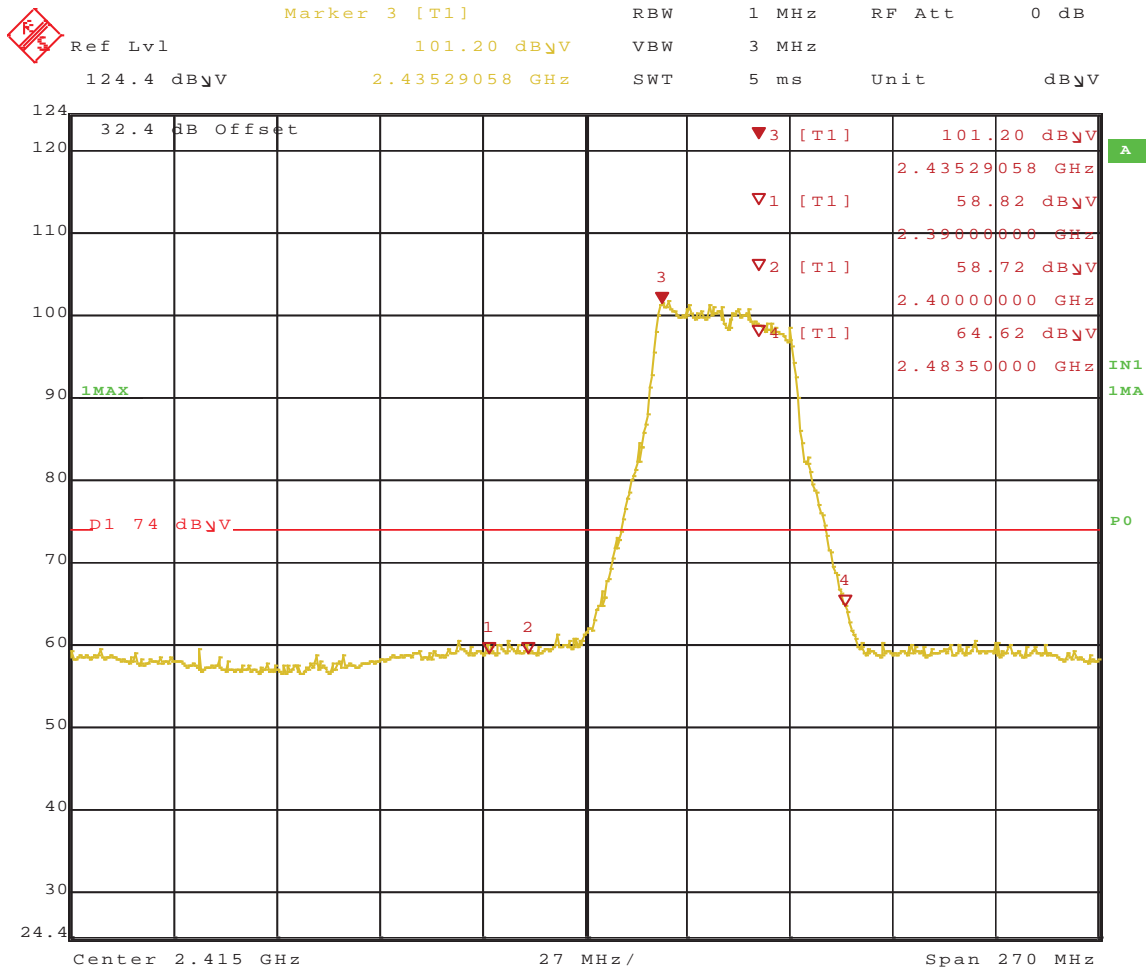

Date: 20.JAN.2011 09:05:14

Figure 345: Radiated Emission at the Edge for Channel 2452MHz at Chain 1 HT40 40.5 Mbps – Horizontal (Peak)

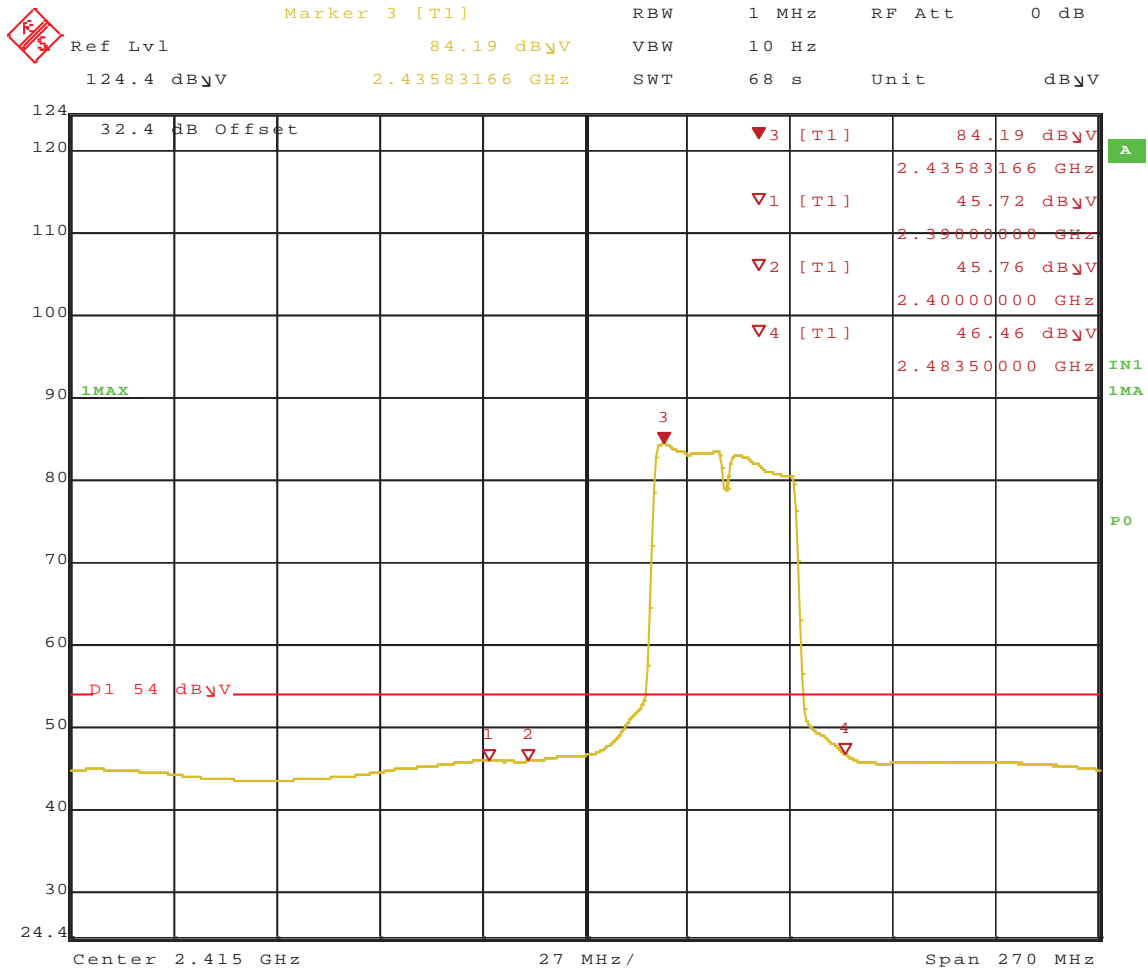

Date: 20.JAN.2011 09:07:20

Figure 346: Radiated Emission at the Edge for Channel 2452MHz at Chain 1 HT40 40.5 Mbps – Horizontal (Ave.)

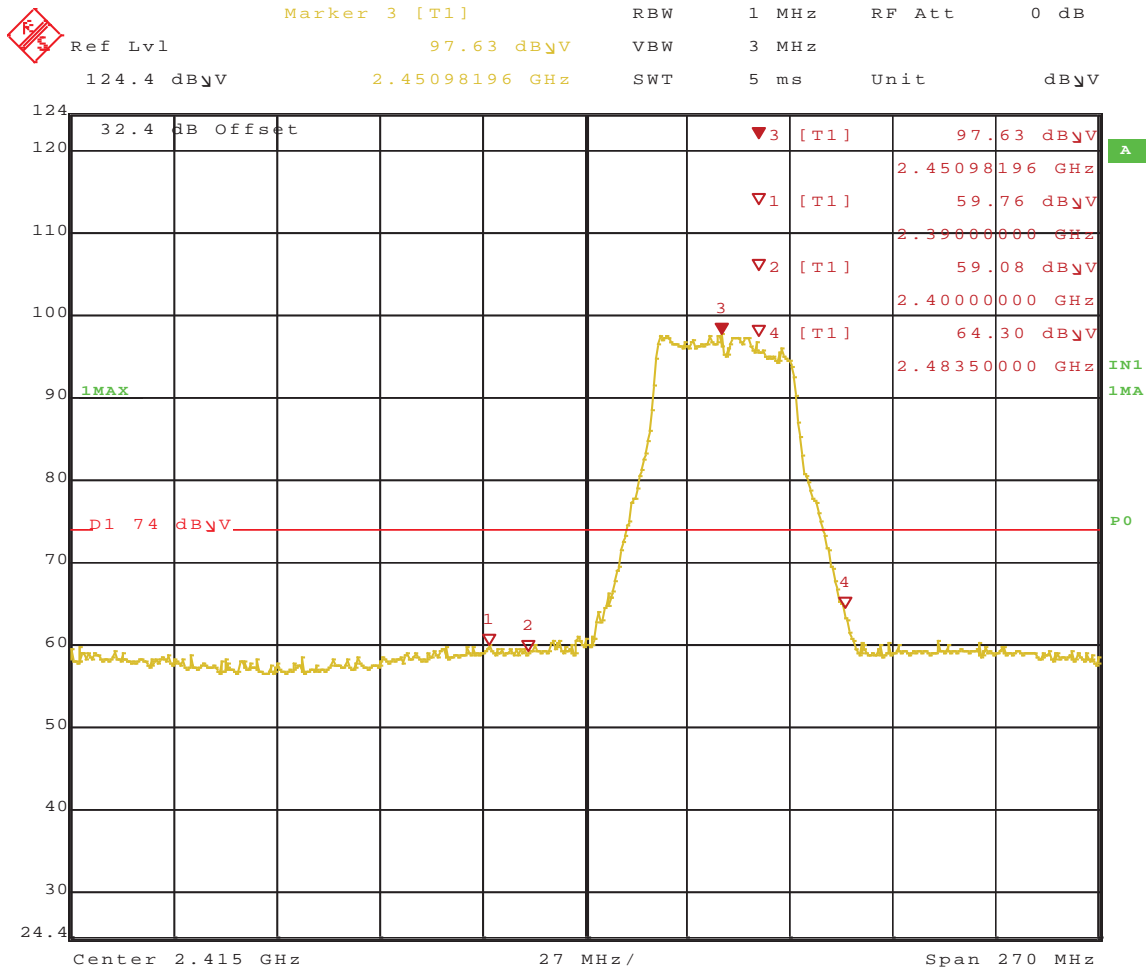

Date: 20.JAN.2011 08:59:07

Figure 347: Radiated Emission at the Edge for Channel 2452MHz at Chain 1 HT40 40.5 Mbps – Vertical (Peak)

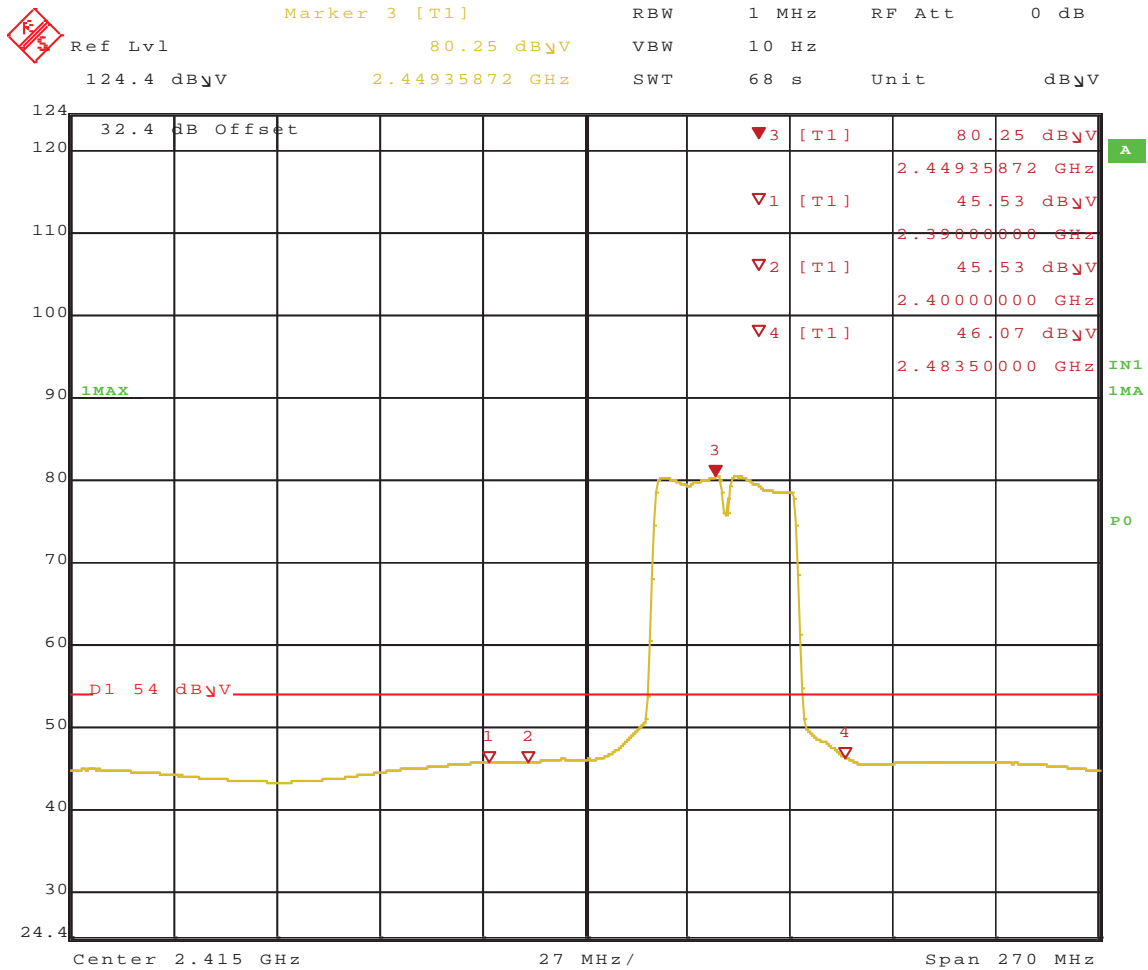

Date: 20.JAN.2011 09:02:28

Figure 348: Radiated Emission at the Edge for Channel 2452MHz at Chain 1 HT40 40.5 Mbps – Vertical (Ave.)

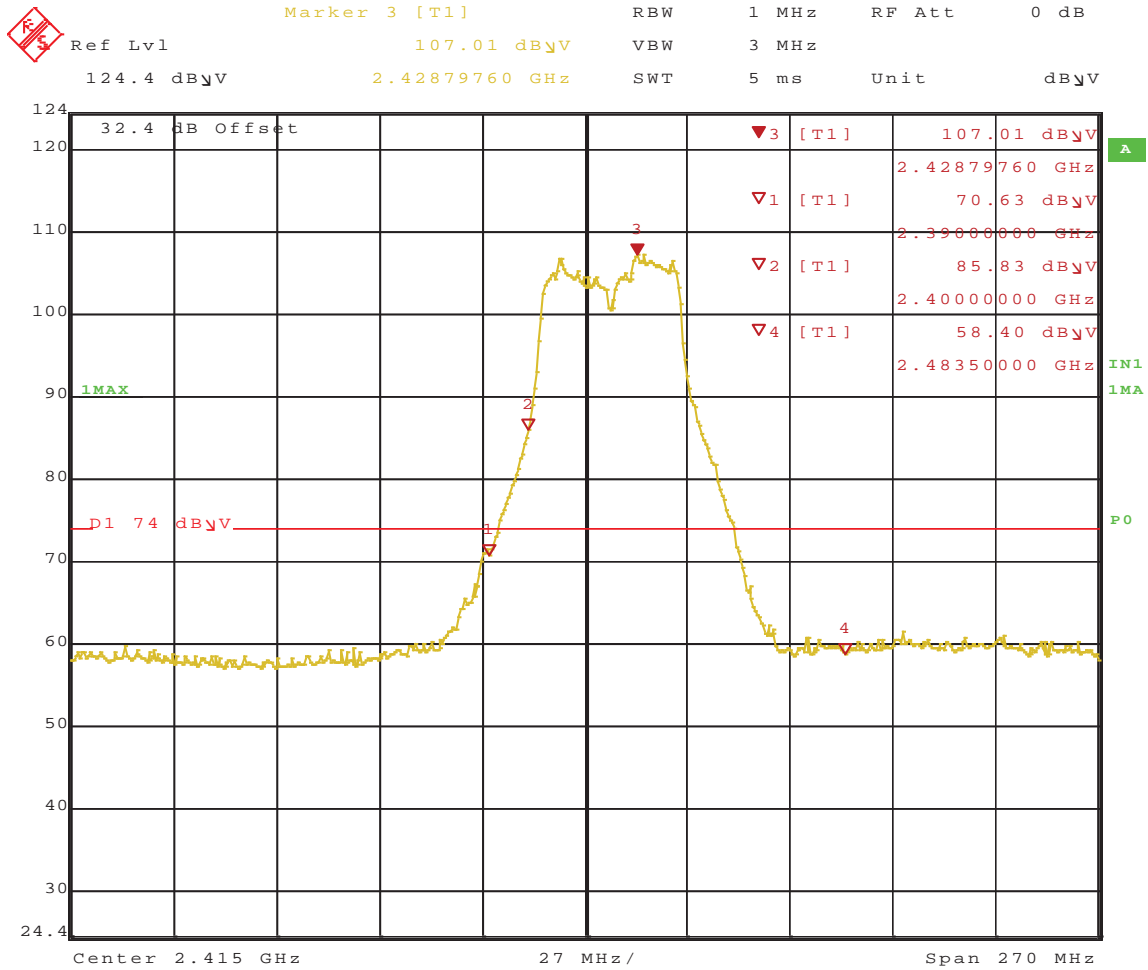

Date: 20.JAN.2011 09:11:42

Figure 349: Radiated Emission at the Edge for Channel 2422MHz at Chain 0 and 1 HT40 54 Mbps – Horizontal (Peak)

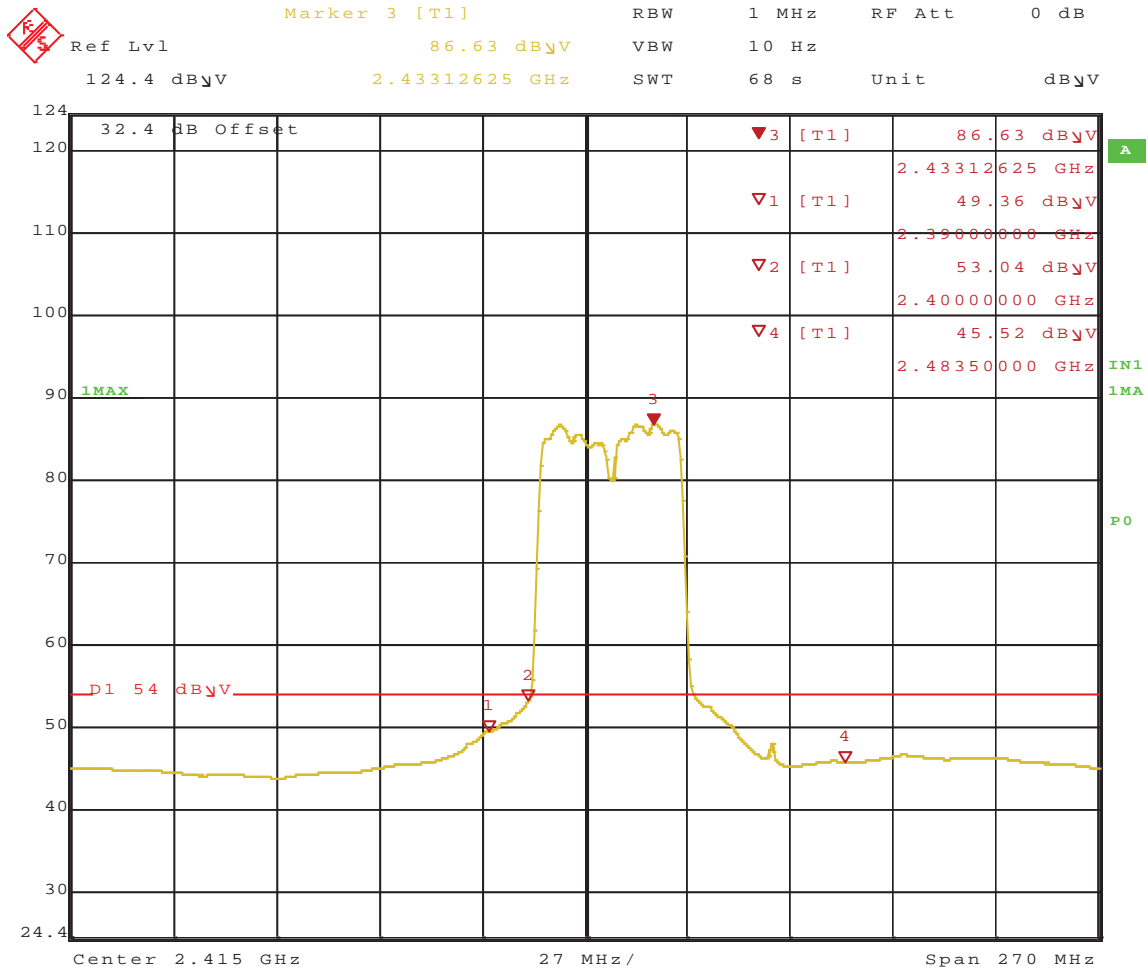

Date: 20.JAN.2011 09:14:25

Figure 350: Radiated Emission at the Edge for Channel 2422MHz Chain 0 and 1 HT40 54 Mbps – Horizontal (Ave.)

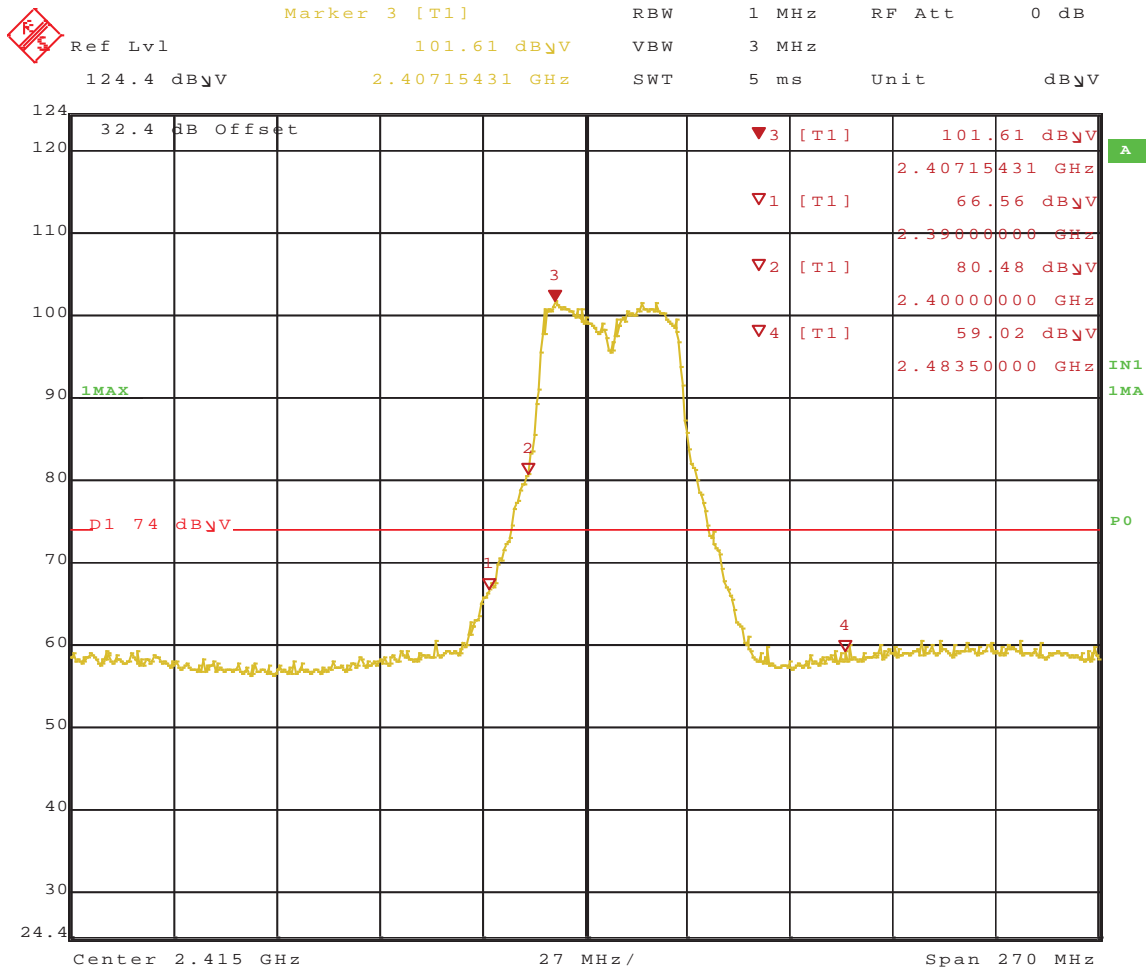

Date: 20.JAN.2011 09:18:29

Figure 351: Radiated Emission at the Edge for Channel 2422MHz at Chain 0 and 1 HT40 54 Mbps – Vertical (Peak)

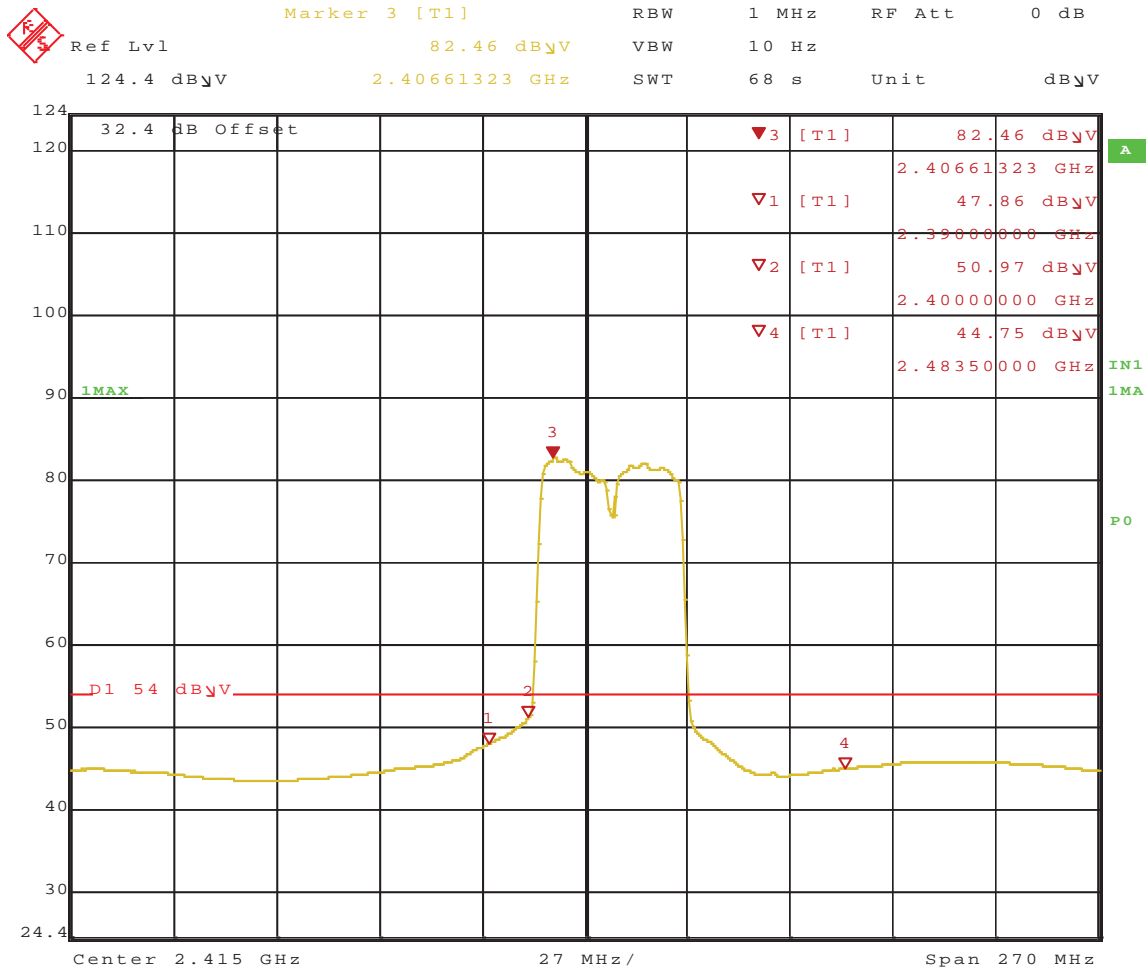

Date: 20.JAN.2011 09:20:10

Figure 352: Radiated Emission at the Edge for Channel 2422MHz at Chain 0 and 1 HT40 54 Mbps – Vertical (Ave.)

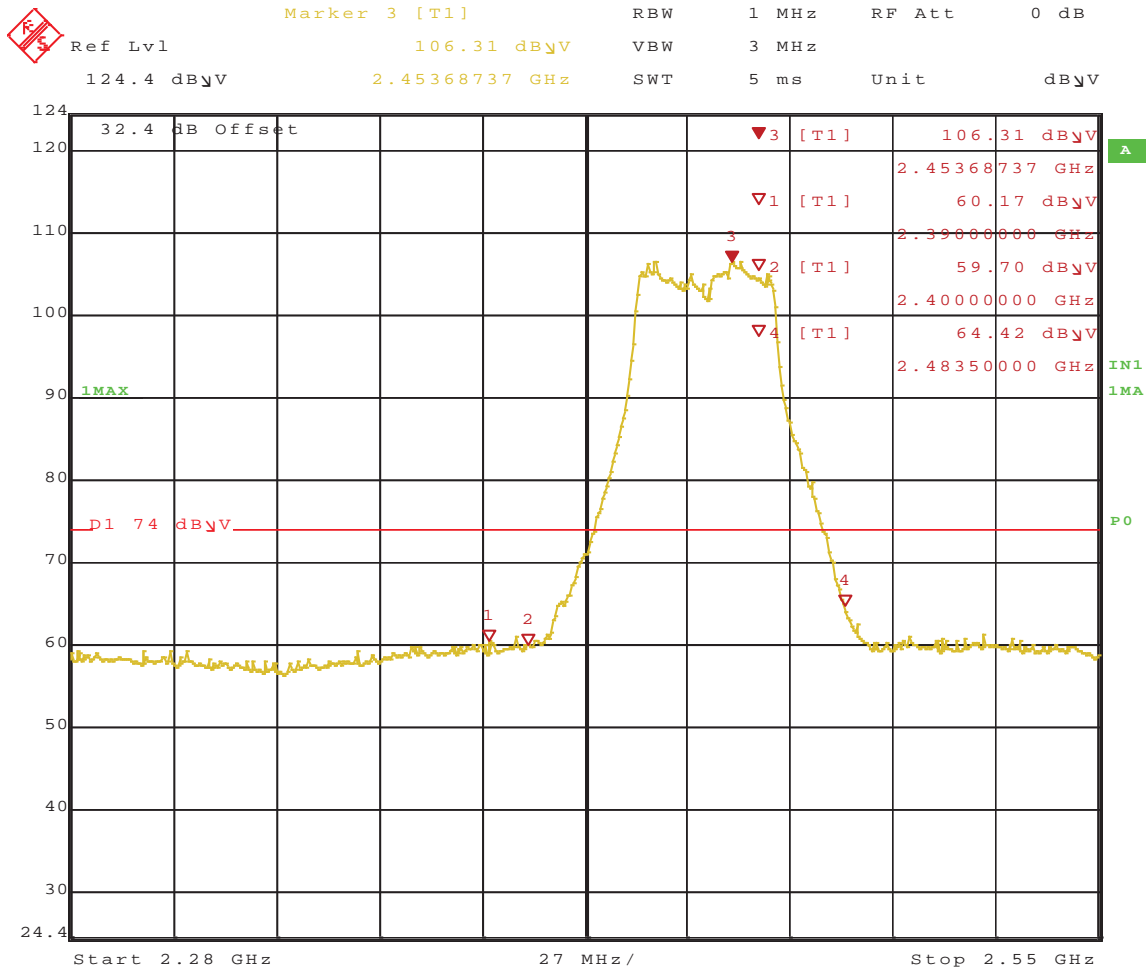

Date: 20.JAN.2011 09:27:48

Figure 353: Radiated Emission at the Edge for Channel 2437MHz at Chain 0 and 1 HT40 54 Mbps – Horizontal (Peak)

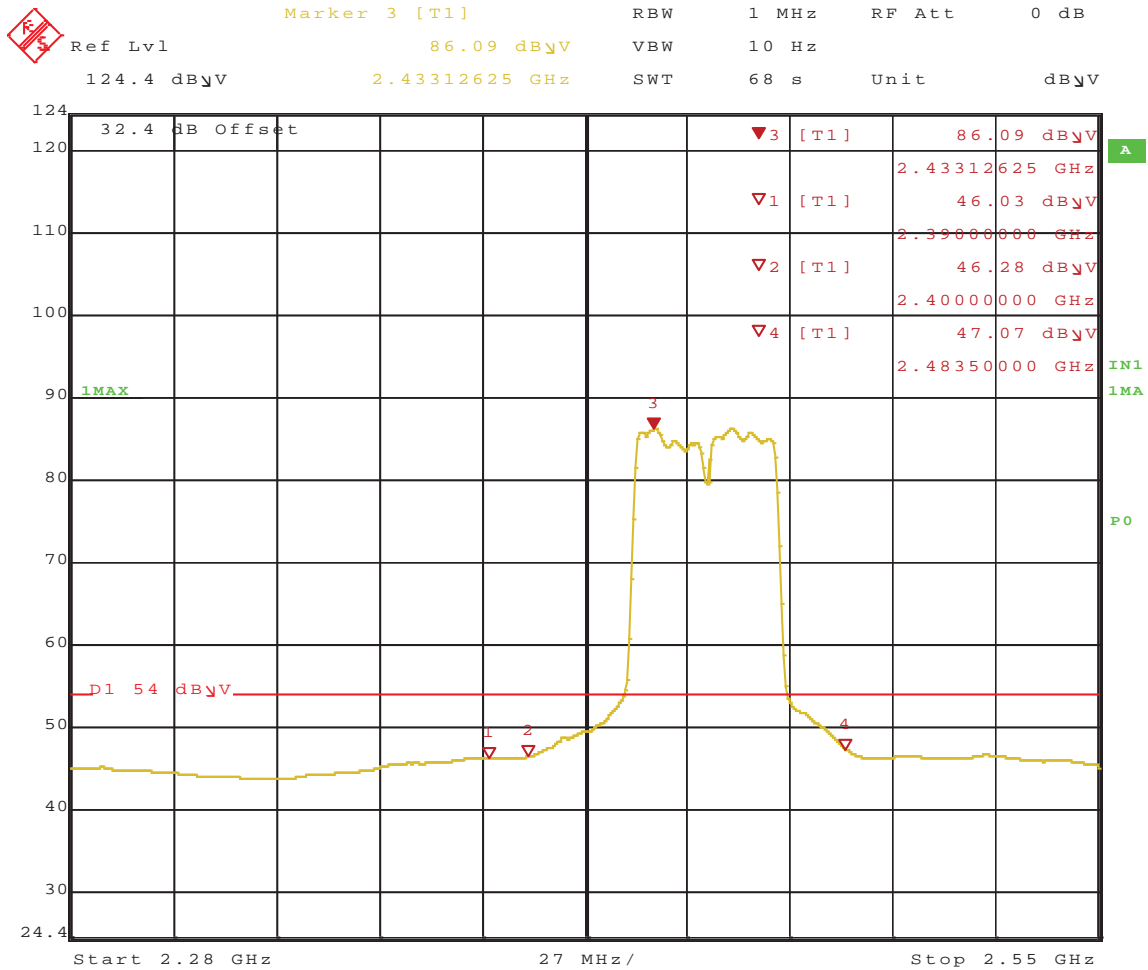

Date: 20.JAN.2011 09:30:27

Figure 354: Radiated Emission at the Edge for Channel 2437MHz at Chain 0 and 1 HT40 54 Mbps – Horizontal (Ave.)

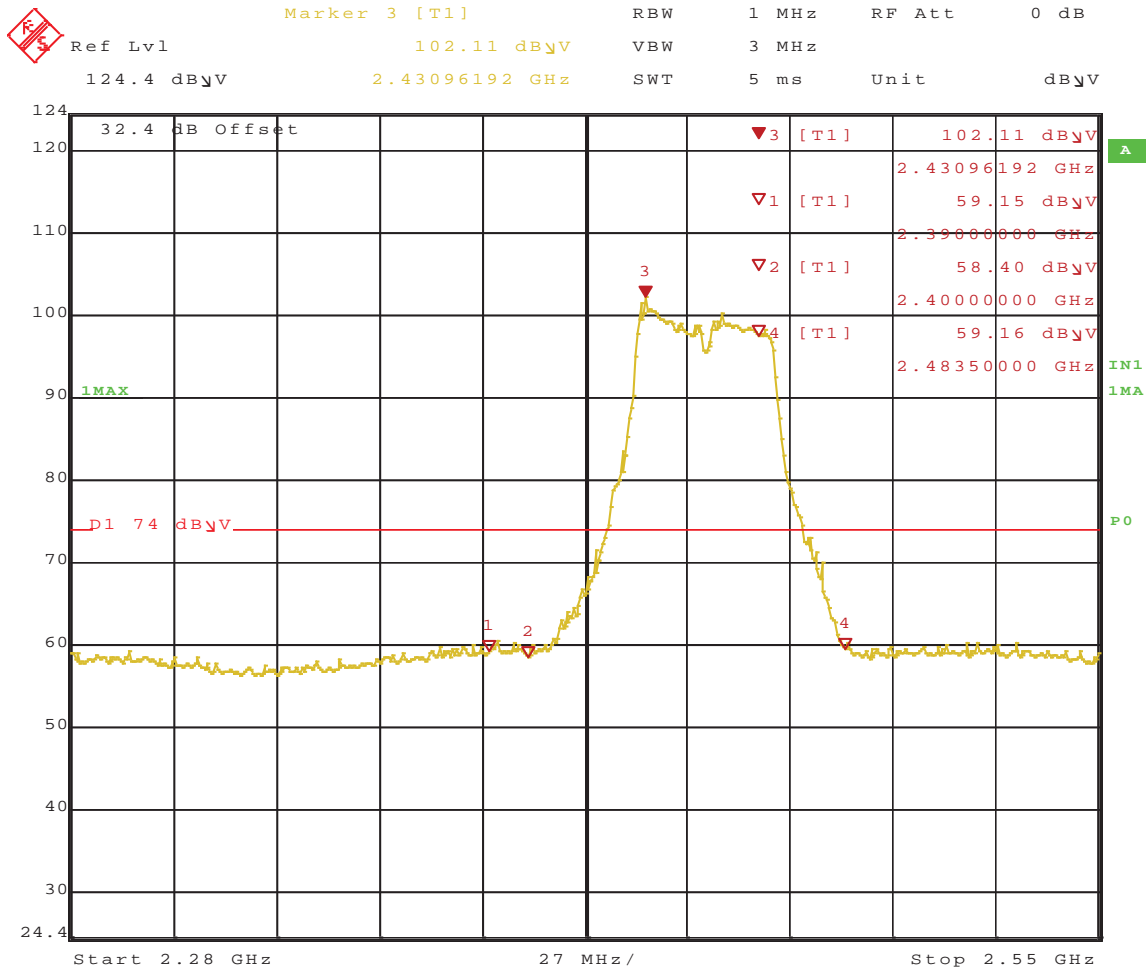

Date: 20.JAN.2011 09:23:23

Figure 355: Radiated Emission at the Edge for Channel 2437MHz at Chain 0 and 1 HT40 54 Mbps – Vertical (Peak)

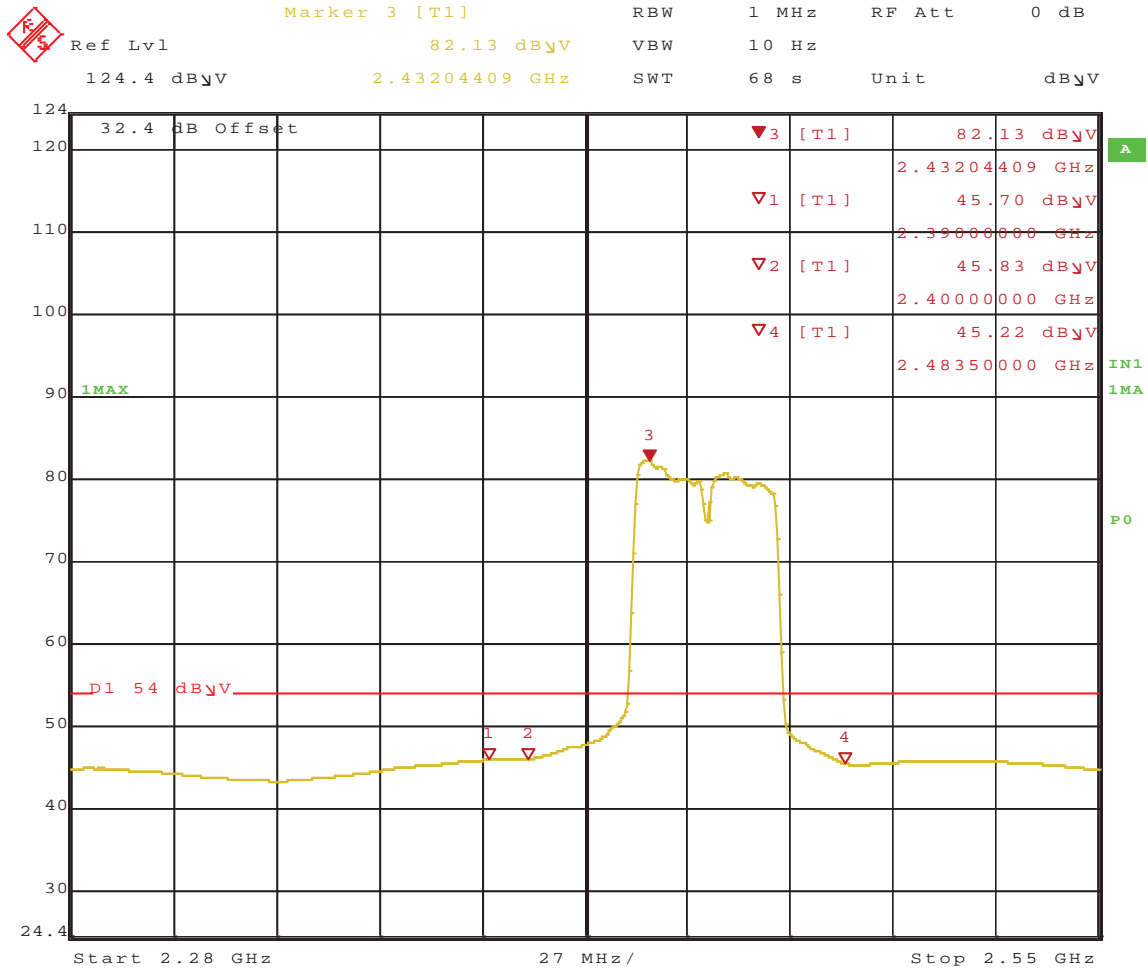

Date: 20.JAN.2011 09:25:07

Figure 356: Radiated Emission at the Edge for Channel 2437MHz at Chain 0 and 1 HT40 54 Mbps – Vertical (Ave.)

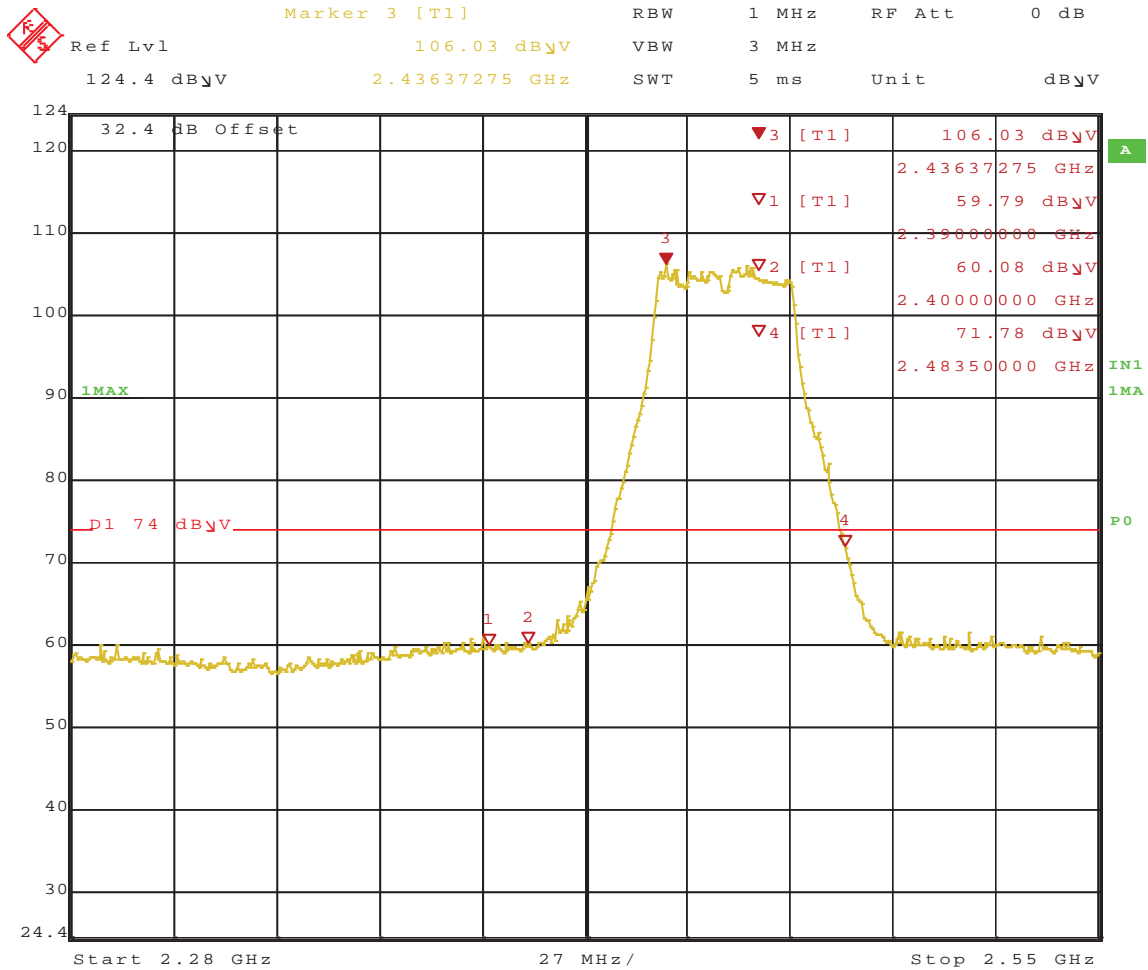

Date: 20.JAN.2011 09:34:35

Figure 357: Radiated Emission at the Edge for Channel 2452MHz at Chain 0 and 1 HT40 54 Mbps – Horizontal (Peak)

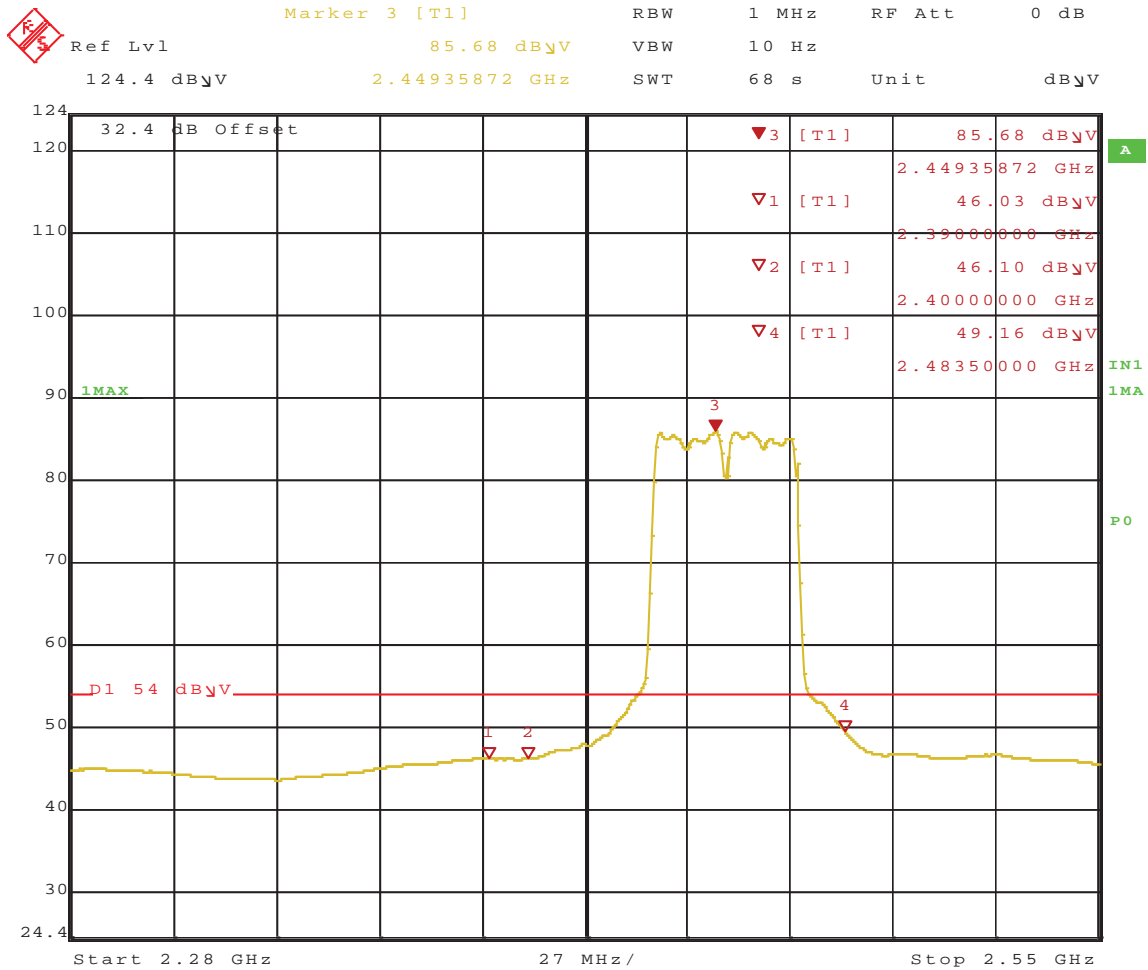

Date: 20.JAN.2011 09:36:24

Figure 358: Radiated Emission at the Edge for Channel 2452MHz at Chain 0 and 1 HT40 54 Mbps – Horizontal (Ave.)

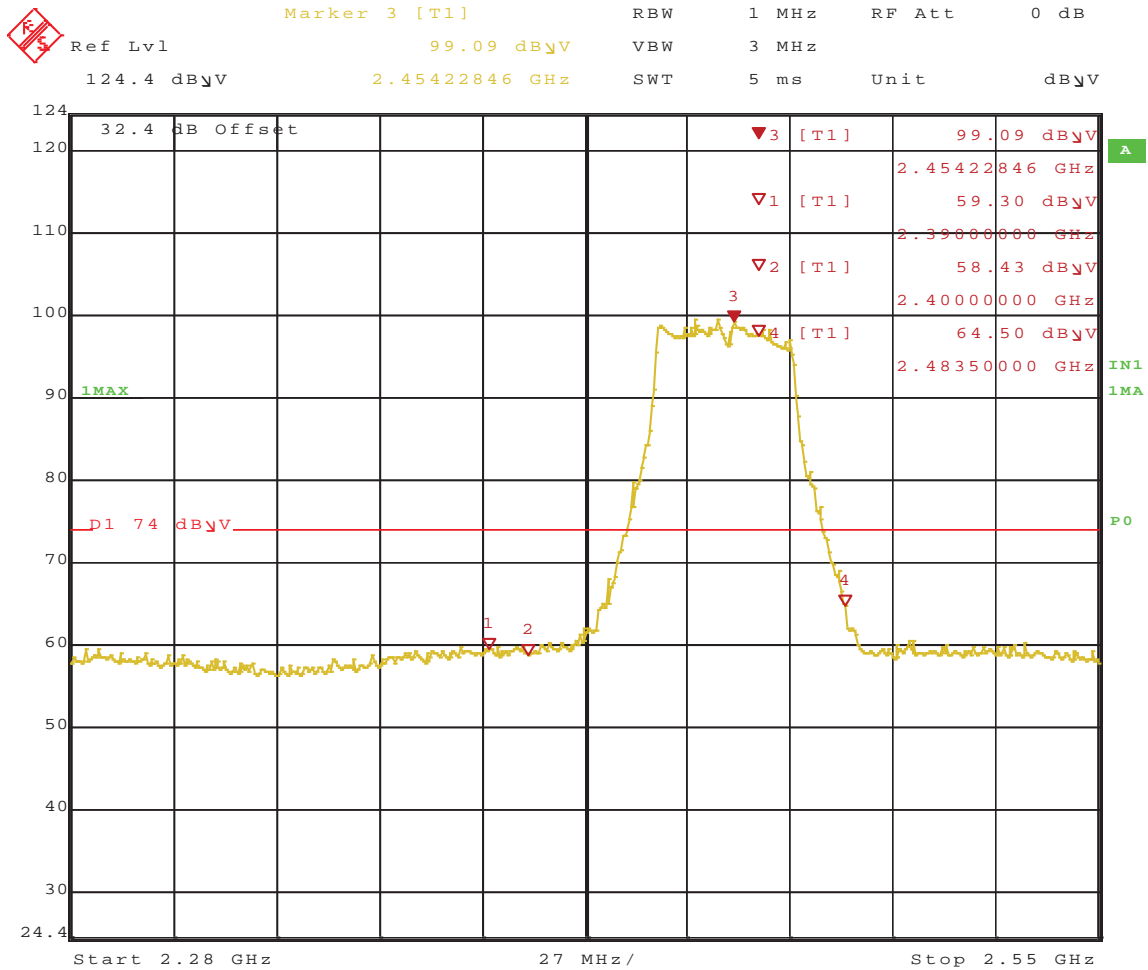

Date: 20.JAN.2011 09:39:06

Figure 359: Radiated Emission at the Edge for Channel 2452MHz at Chain 0 and 1 HT40 54 Mbps – Vertical (Peak)

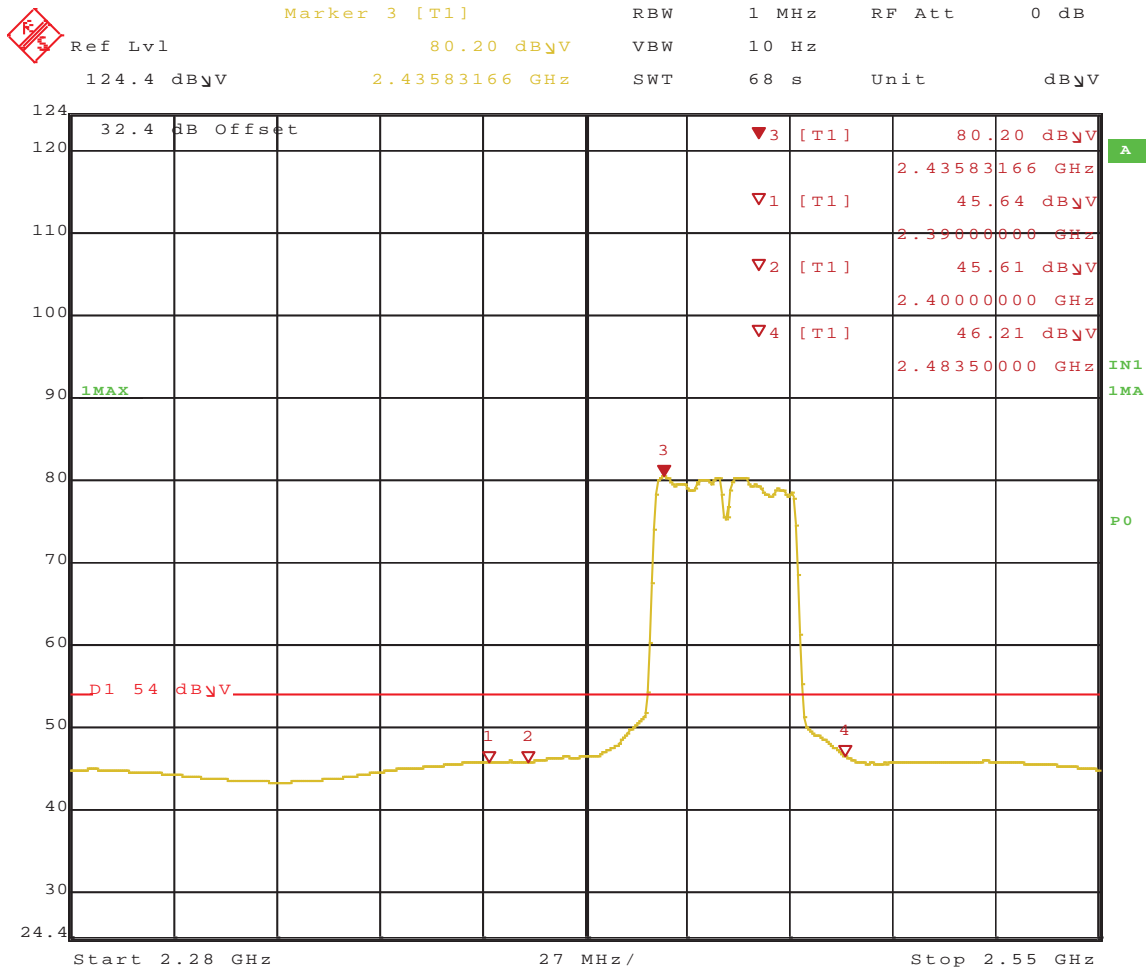

Date: 20.JAN.2011 09:40:34

Figure 360: Radiated Emission at the Edge for Channel 2452MHz at Chain 0 and 1 HT40 54 Mbps – Vertical (Ave)

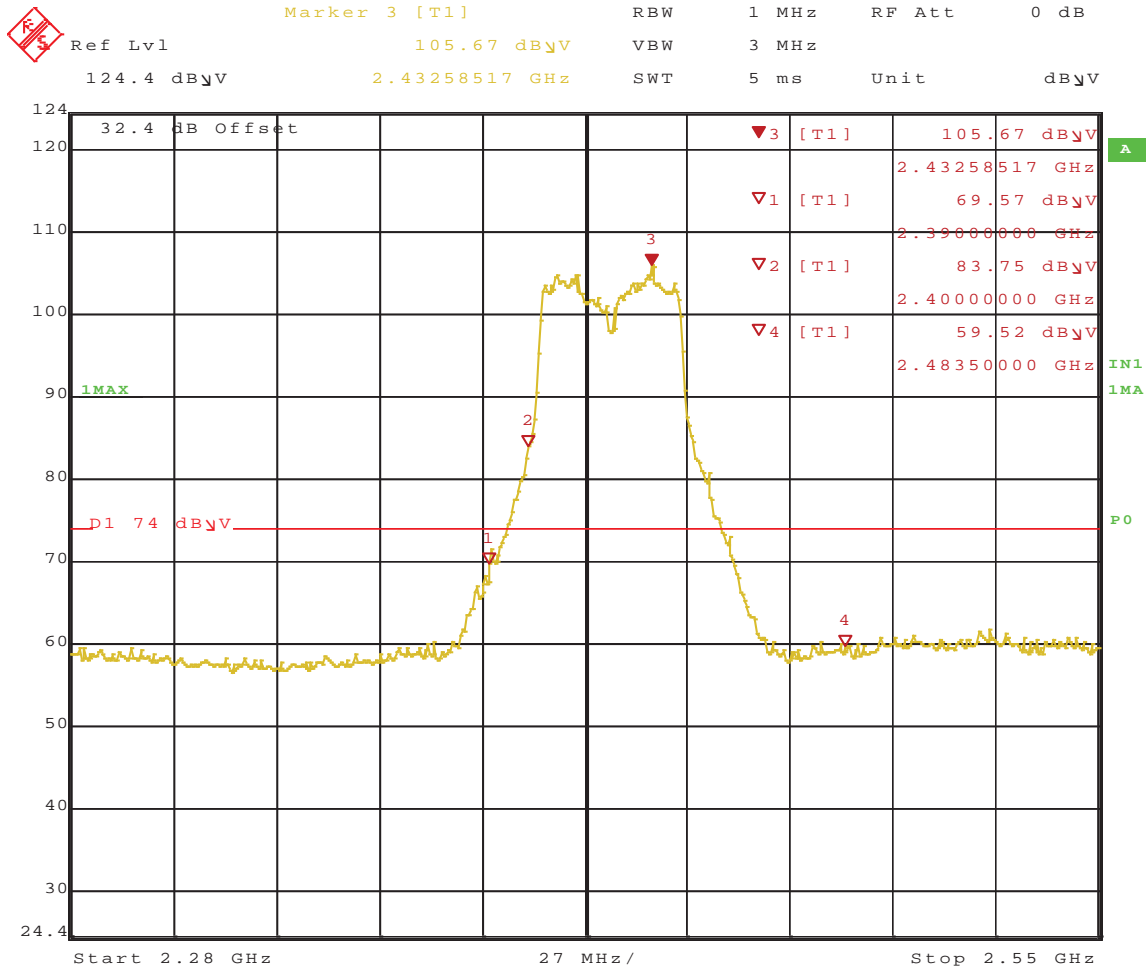

Date: 20.JAN.2011 09:51:33

Figure 361: Radiated Emission at the Edge for Channel 2422MHz at Chain 0, 1, and 2 HT40 405Mbps – Horizontal (Peak)

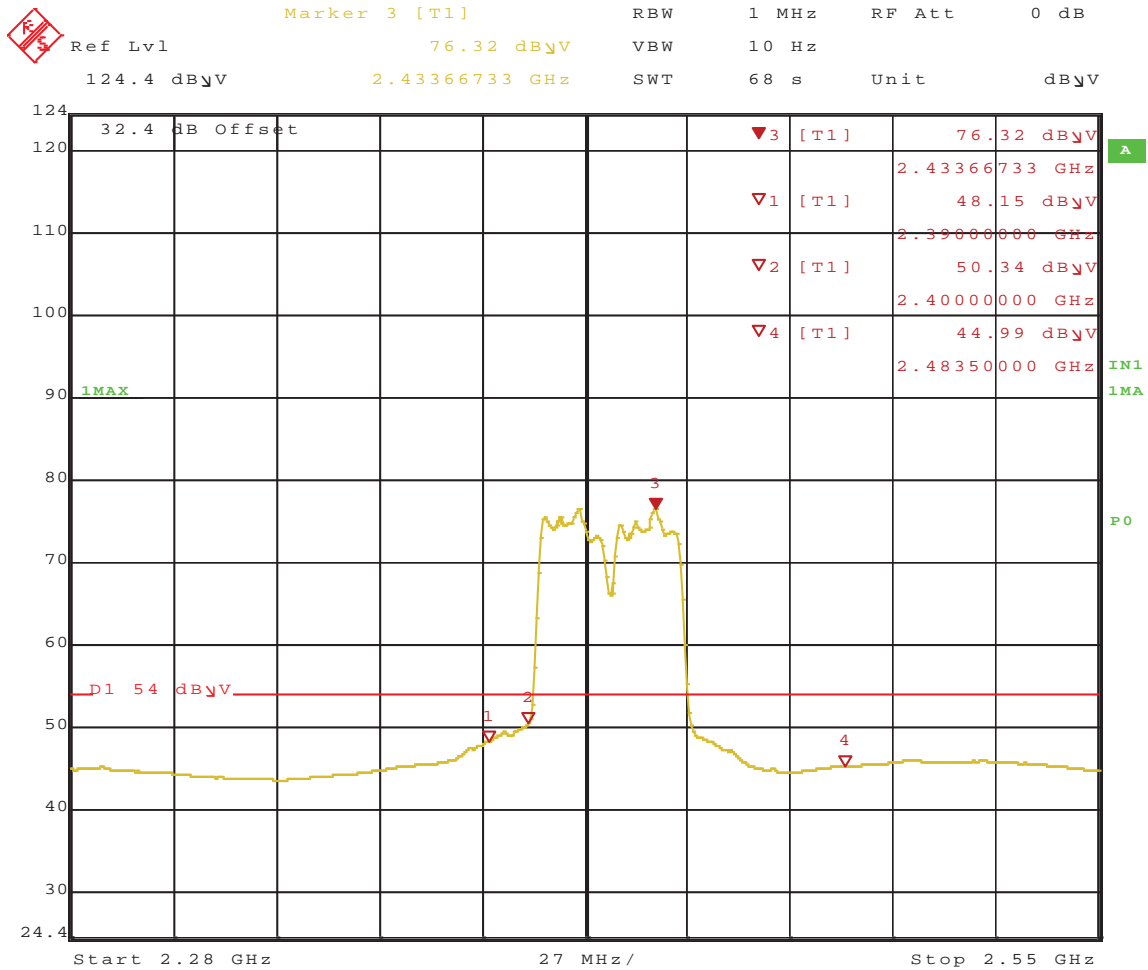

Date: 20.JAN.2011 09:53:08

Figure 362: Radiated Emission at the Edge for Channel 2422MHz Chain 0, 1, and 2 HT40 405Mbps – Horizontal (Ave.)

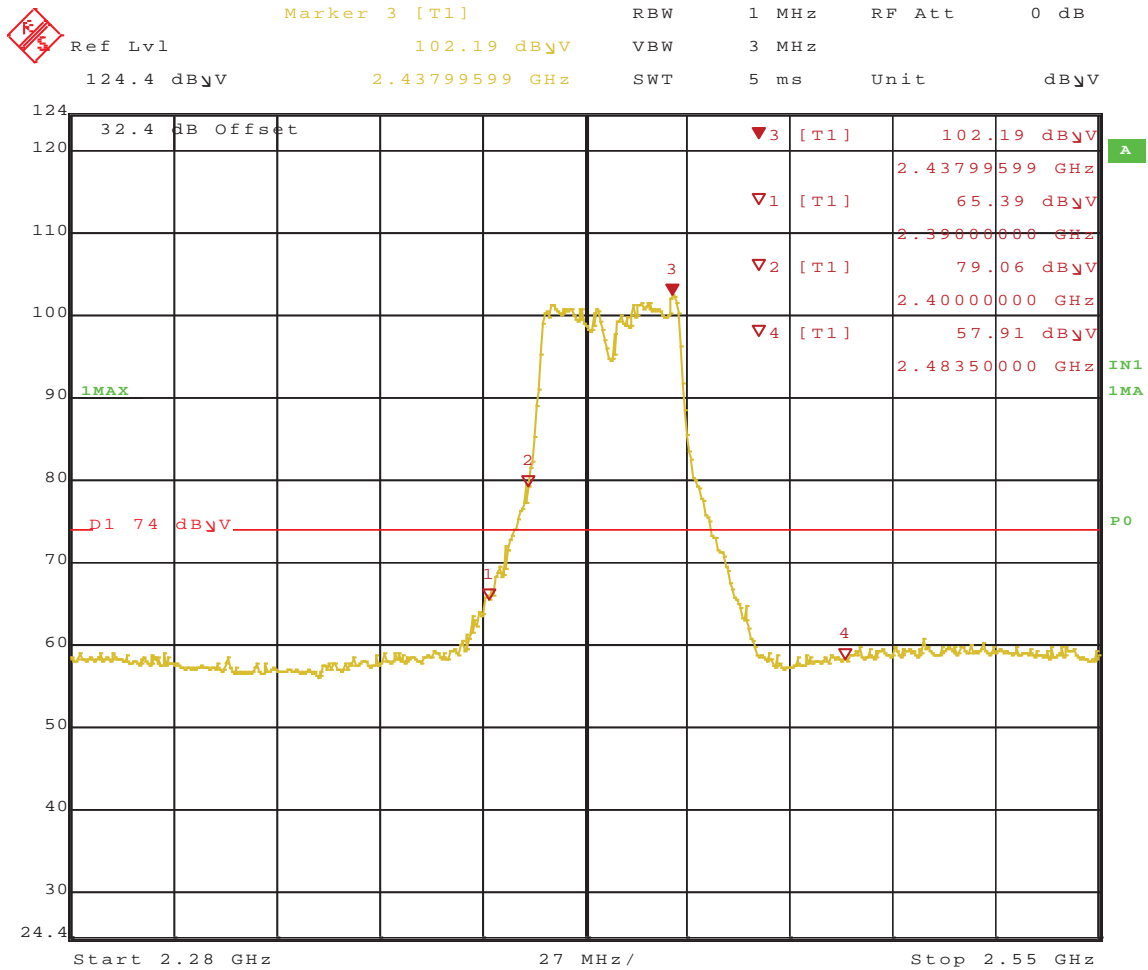

Date: 20.JAN.2011 09:43:58

Figure 363: Radiated Emission at the Edge for Channel 2422MHz at Chain 0, 1, and 2 HT40 405Mbps – Vertical (Peak)

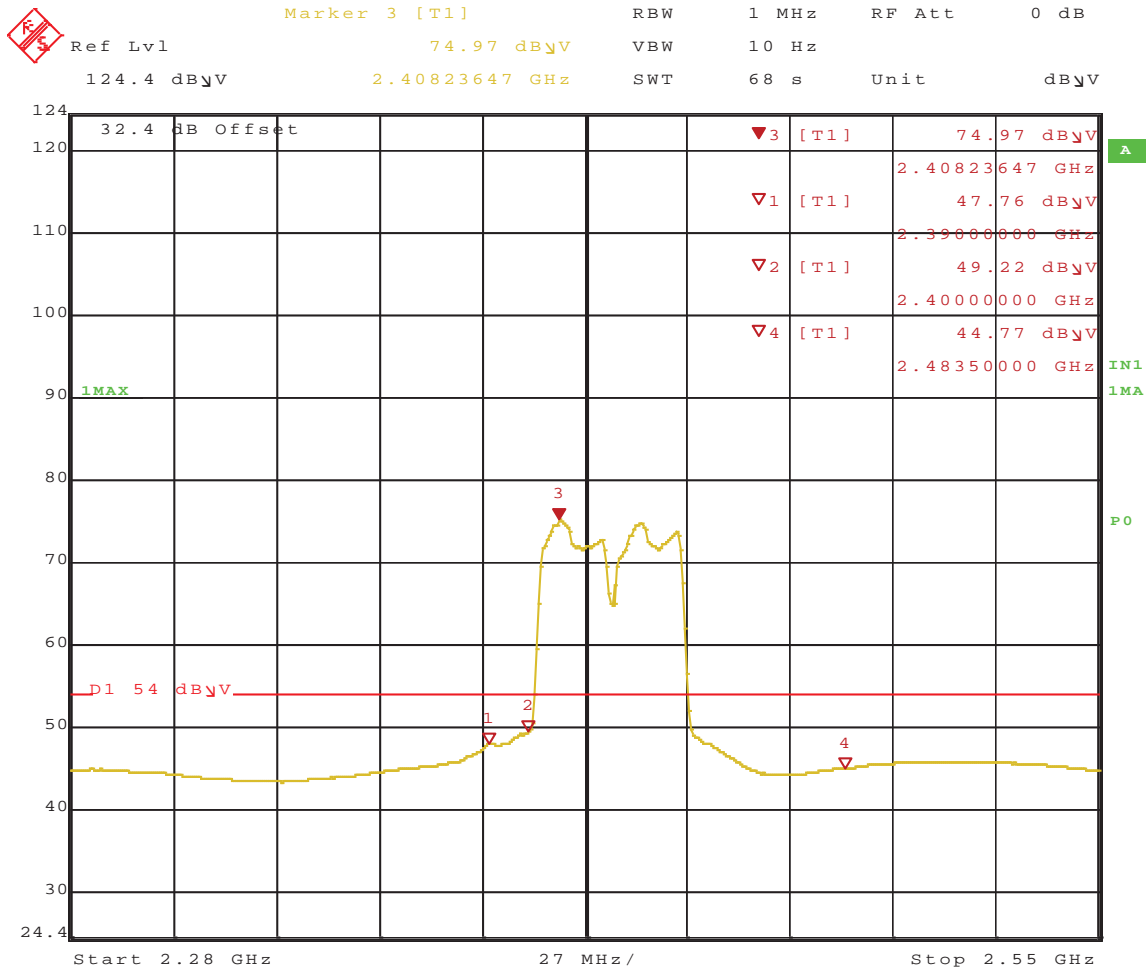

Date: 20.JAN.2011 09:45:50

Figure 364: Radiated Emission at the Edge for Channel 2422MHz at Chain 0, 1, and 2 HT40 405Mbps – Vertical (Ave.)

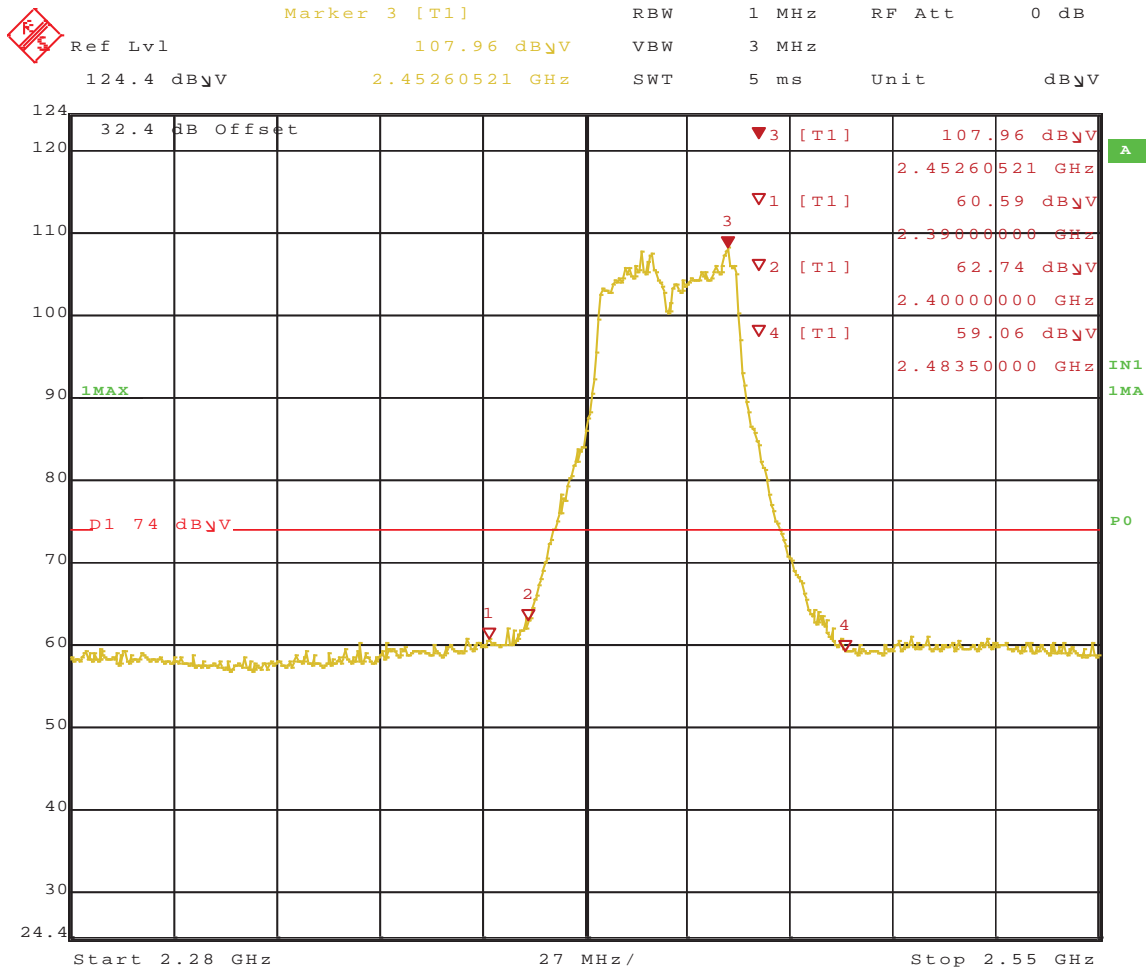

Date: 20.JAN.2011 09:56:40

Figure 365: Radiated Emission at the Edge for Channel 2437MHz at Chain 0, 1, and 2 HT40 405Mbps – Horizontal (Peak)

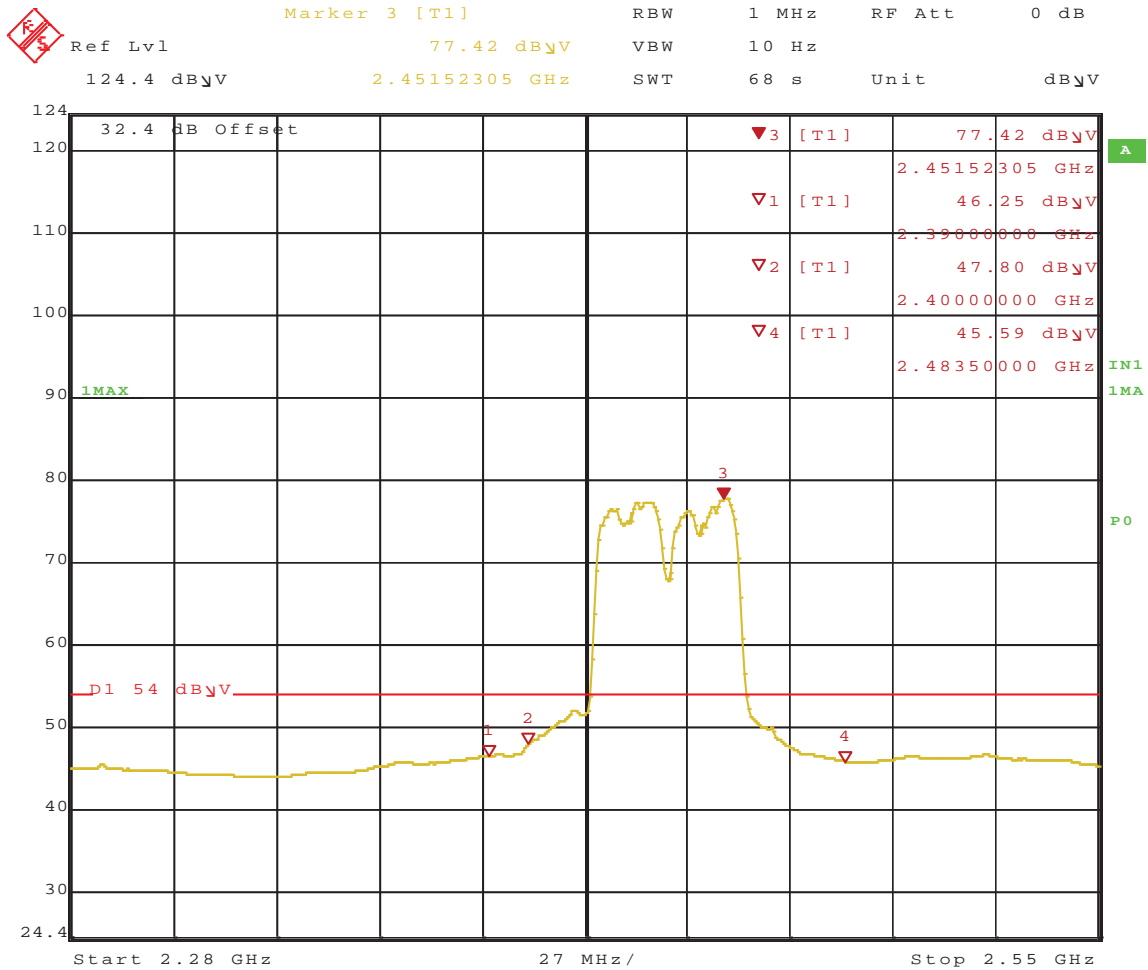

Date: 20.JAN.2011 09:58:28

Figure 366: Radiated Emission at the Edge for Channel 2437MHz at Chain 0, 1, and 2 HT40 405Mbps – Horizontal (Ave.)

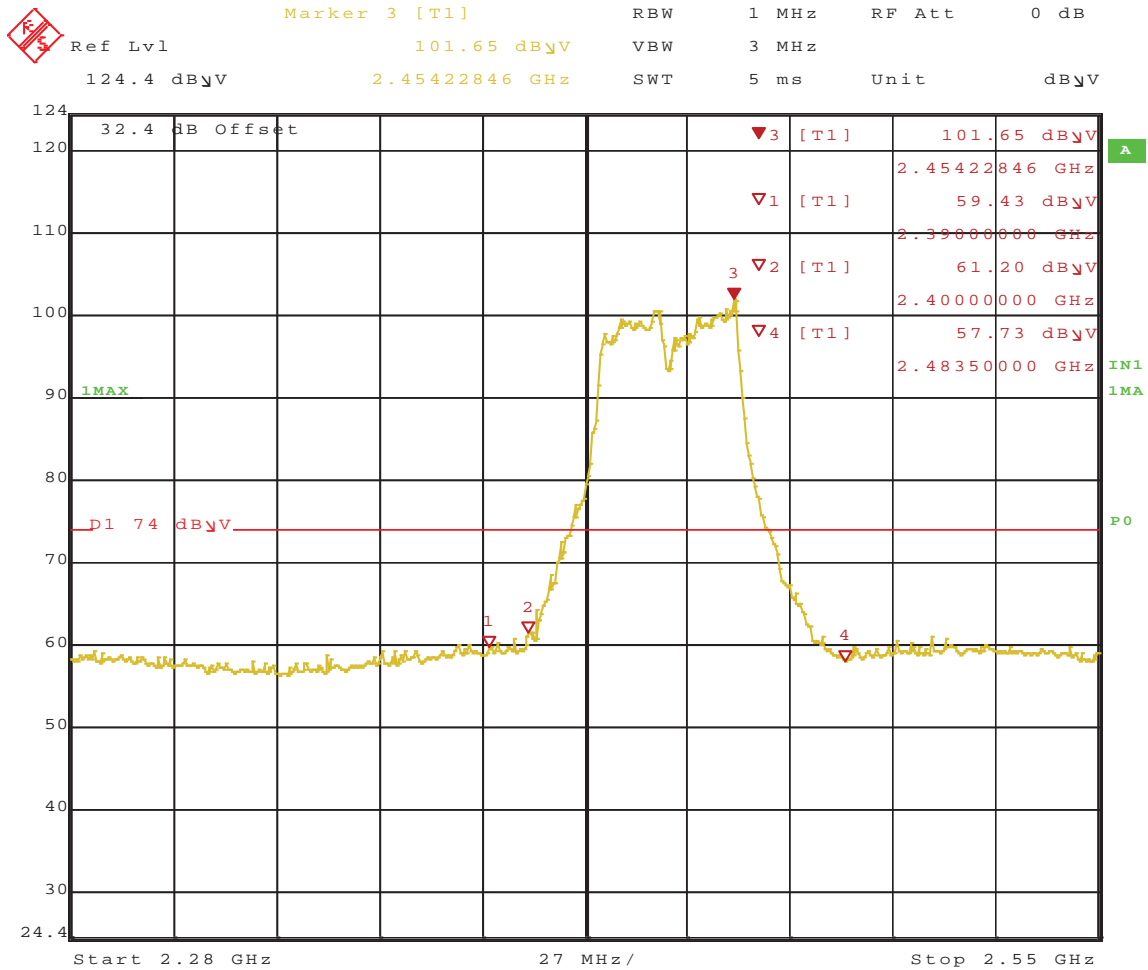

Date: 20.JAN.2011 10:01:47

Figure 367: Radiated Emission at the Edge for Channel 2437MHz at Chain 0, 1, and 2 HT40 405Mbps – Vertical (Peak)

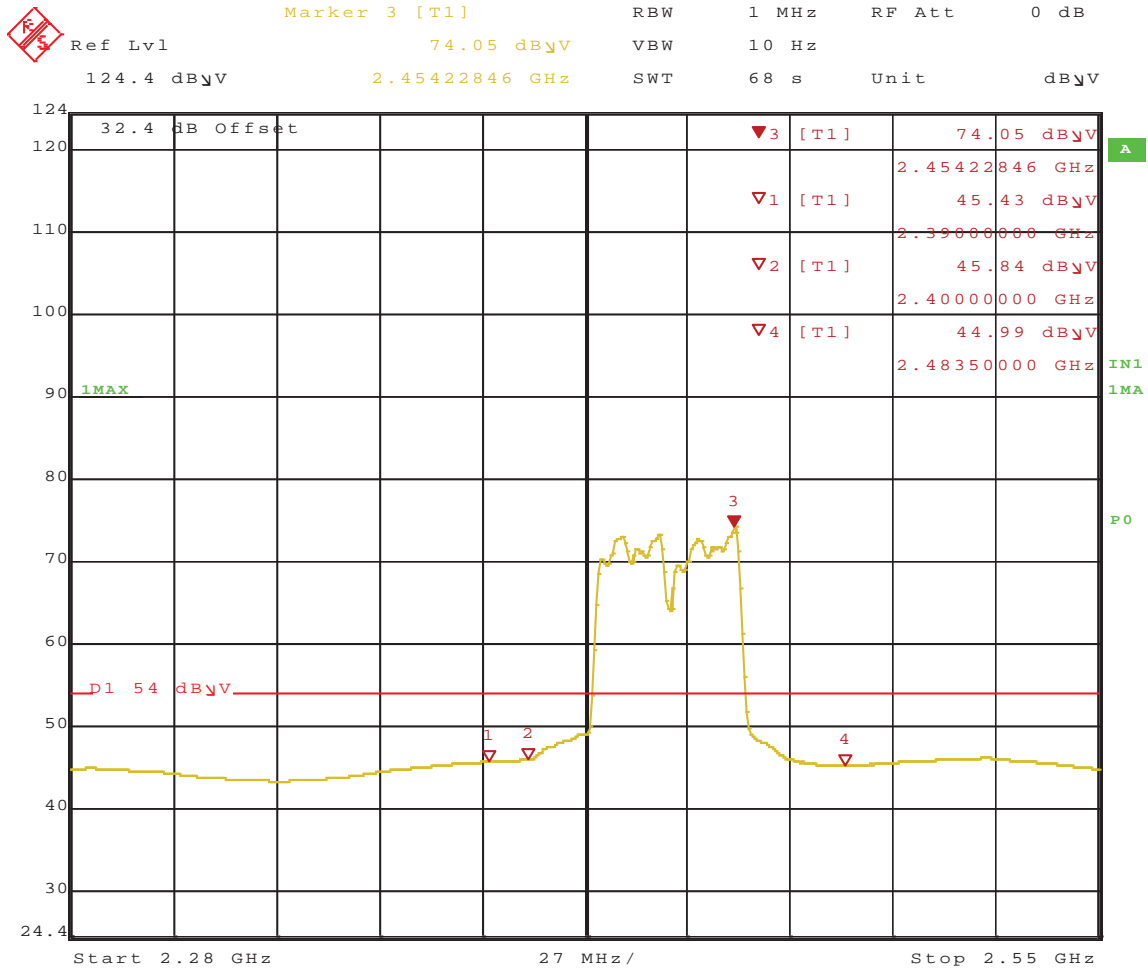

Date: 20.JAN.2011 10:03:26

Figure 368: Radiated Emission at the Edge for Channel 2437MHz at Chain 0, 1, and 2 HT40 405Mbps – Vertical (Ave.)

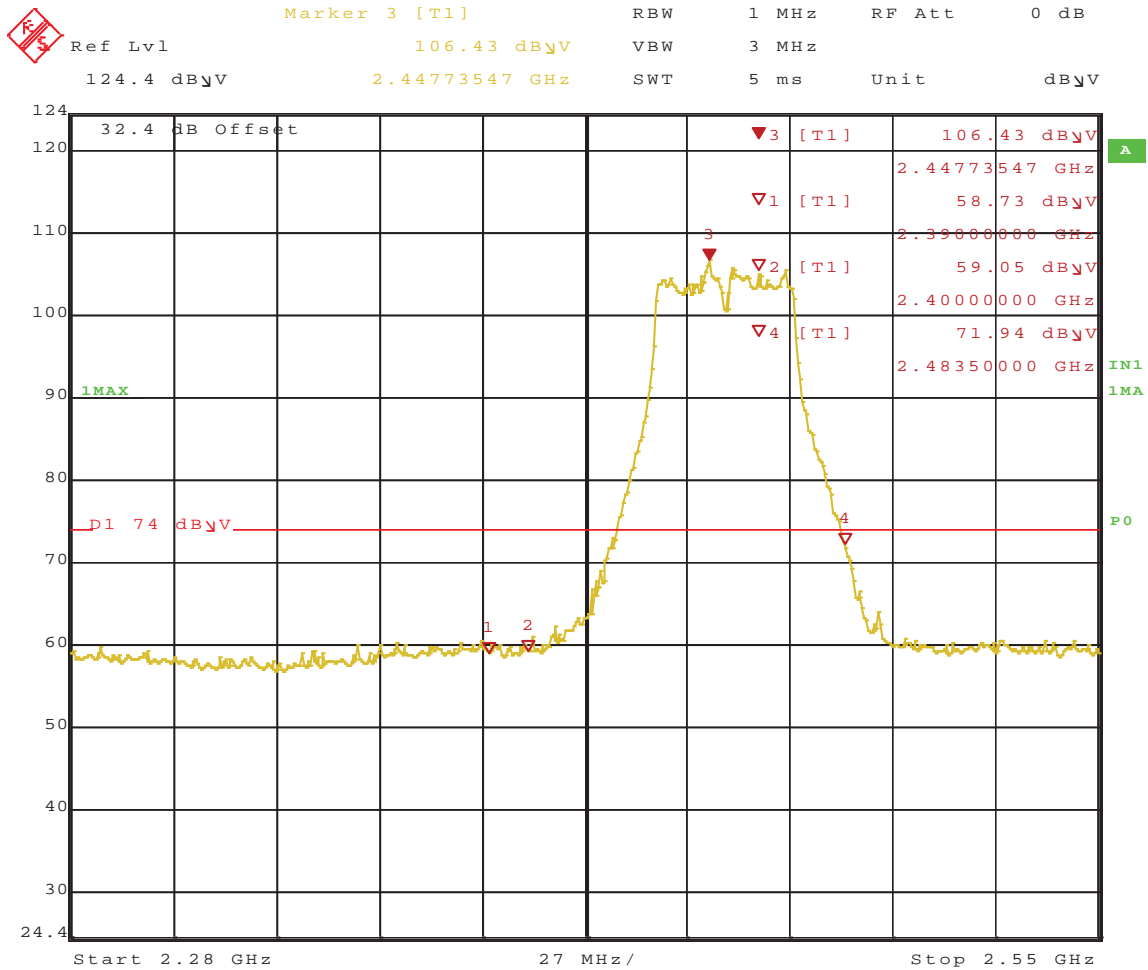

Date: 20.JAN.2011 10:10:26

Figure 369: Radiated Emission at the Edge for Channel 2452MHz at Chain 0, 1, and 2 HT40 405Mbps – Horizontal (Peak)

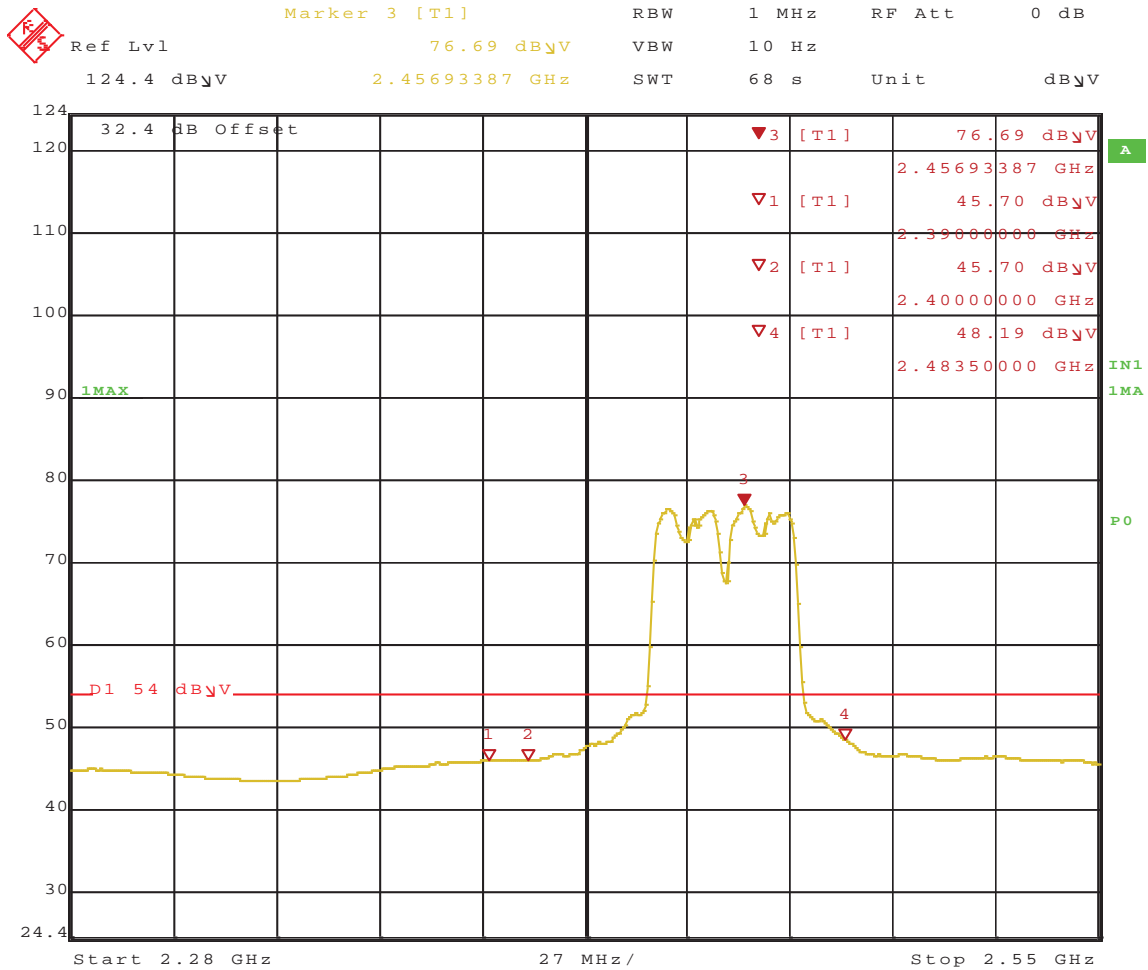

Date: 20.JAN.2011 10:12:04

Figure 370: Radiated Emission at the Edge for Channel 2452MHz at Chain 0, 1, and 2 HT40 405Mbps – Horizontal (Ave.)

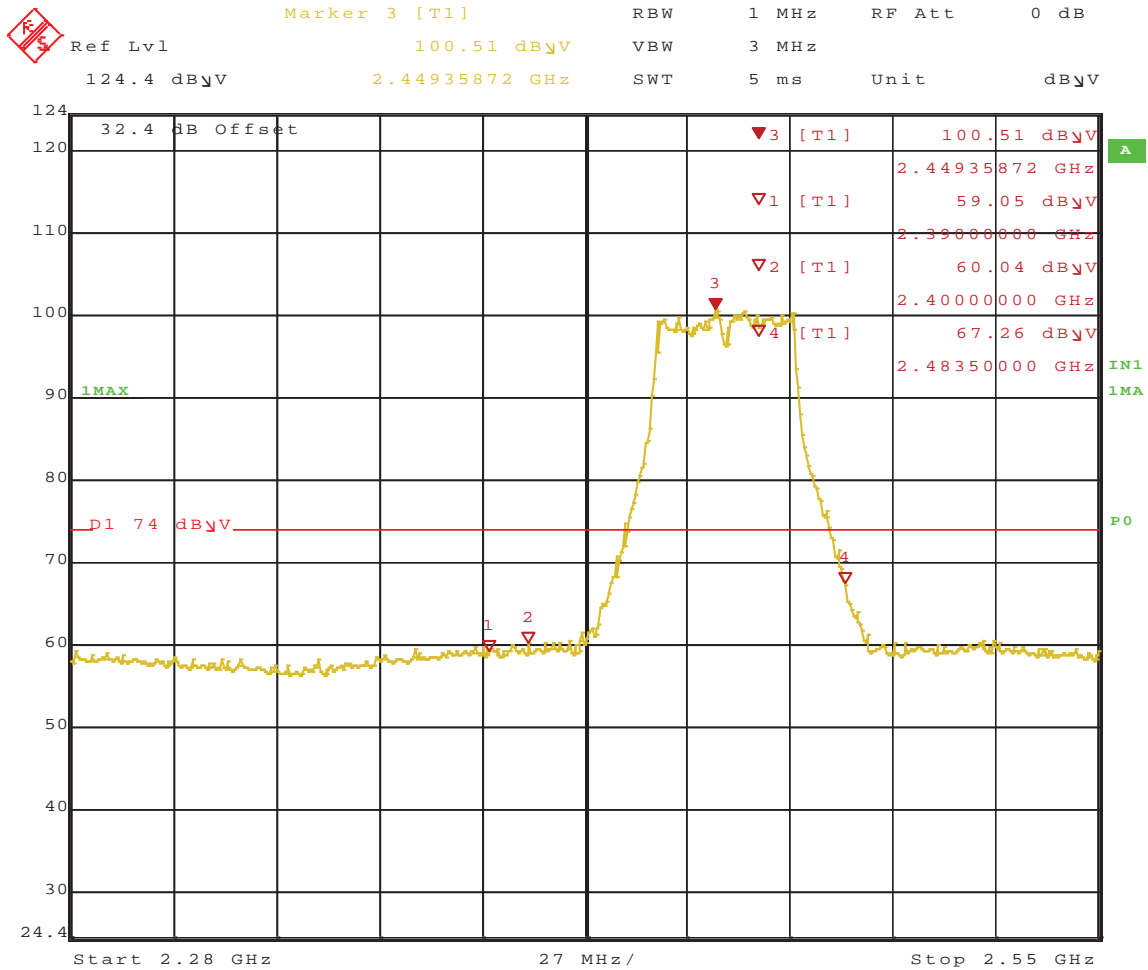

Date: 20.JAN.2011 10:06:23

Figure 371: Radiated Emission at the Edge for Channel 2452MHz at Chain 0, 1, and 2 HT40 405Mbps – Vertical (Peak)

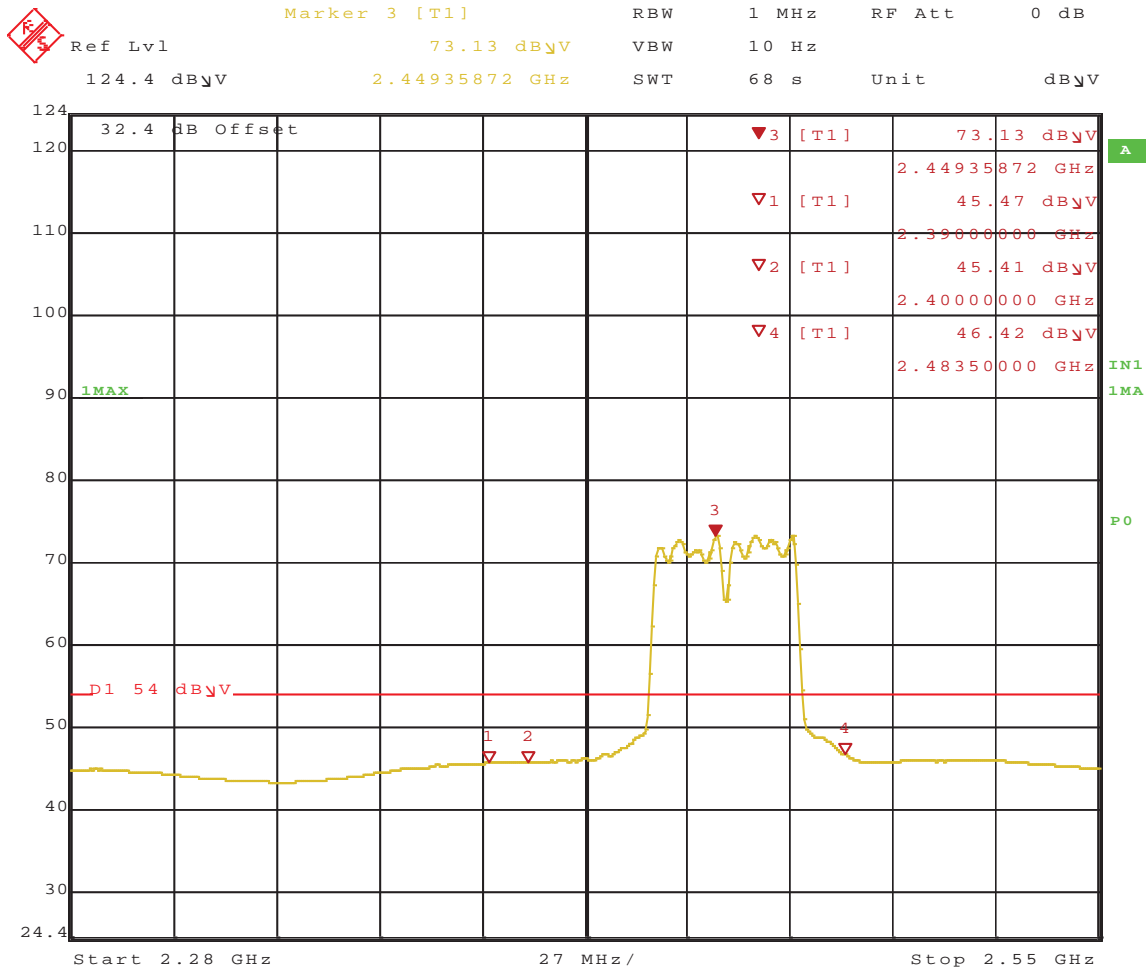

Date: 20.JAN.2011 10:07:57

Figure 372: Radiated Emission at the Edge for Channel 2452MHz at Chain 0, 1, and 2 HT40 405Mbps – Vertical (Ave)

SOP 1 Radiated Emissions											Tracking # 31053887.001 Page 1 of 32	
EUT Name		OPTIVIEW XG, OPVXG, OPTIVIEW XG-10G, OPVXG-10G, OPVXGPRO, OPVXG-EXPT, OPTIVIEW XG-LAN, OPVXG-LAN, OPVXG-LAN-10G, OPTIVIEW XG WLAN, OPVXG-WLAN						Date		January 18, 2011		
EUT Model		3365336, 3949539, 3949542, 3949556, 3949616, 4020634						Temp / Hum in		23°C / 39%rh		
EUT Serial		Prototype						Temp / Hum out		N/A		
EUT Config.		Y-Axis, 12dBm, 802.11b at 1Mbps						Line AC / Freq		120Vac/60Hz		
Standard		CFR47 Part 15 Subpart C						RBW / VBW		1 MHz/ 3 MHz		
Dist/Ant Used		3m / EMCO3115 / 1m - RA42-K-F-4B-C						Performed by		Jeremy Luong		
Emission Freq (MHz)	ANT Polar (H/V)	ANT Pos (cm)	Table Pos (deg)	FIM (Pk) (dBuV/m)	FIM Ave (dBuV/m)	Total CF (dBuV)	E-Field Ave (dBuV/m)	Spec Limit (dBuV/m)	Spec Margin (dB)	Type		
Transmitted Data at 2412MHz												
1861.27	H	101	231	57.11	43.00	-4.94	38.06	53.98	-15.92	Spurious		
4824.05	H	182	104	43.42	35.31	2.42	37.73	53.98	-16.25	Harmonic		
4824.10	V	201	77	43.49	39.22	2.42	41.64	53.98	-12.34	Harmonic		
Transmitted Data at 2437MHz												
1861.09	H	101	207	56.94	42.97	-4.94	38.03	53.98	-15.95	Spurious		
4874.02	V	198	358	42.90	39.10	2.52	41.62	53.98	-12.36	Harmonic		
4874.04	H	194	187	40.39	30.31	2.52	32.83	53.98	-21.15	Harmonic		
Transmitted Data at 2462MHz												
1595.77	H	196	247	58.38	38.22	-6.83	31.39	53.98	-22.59	Spurious		
1861.27	H	99	205	56.84	42.78	-4.94	37.84	53.98	-16.14	Spurious		
4924.04	V	178	127	41.12	31.64	2.60	34.24	53.98	-19.74	Harmonic		
4924.11	H	117	46	40.38	30.54	2.60	33.14	53.98	-20.84	Harmonic		
Spec Margin = E-Field QP - Limit, E-Field QP = FIM QP+ Total CF ± Uncertainty												
Total CF= Amp Gain + Cable Loss + ANT Factor												
Combined Standard Uncertainty $u_c(y) = \pm 3.2$ dB Expanded Uncertainty $U = k u_c(y)$ $k = 2$ for 95% confidence												
Notes: Worst case was observed on Y-axis, 1Mbps. The output Chain 1 of the right radio was transmitted at +12dBm.												

SOP 1 Radiated Emissions

Tracking # 31053887.001 Page 2 of 32

EUT Name	OPTIVIEW XG, OPVXG, OPTIVIEW XG-10G, OPVXG-10G, OPVXGPRO, OPVXG-EXPT, OPTIVIEW XG-LAN, OPVXG-LAN, OPVXG-LAN-10G, OPTIVIEW XG WLAN, OPVXG-WLAN	Date	January 18, 2011
EUT Model	3365336, 3949539, 3949542, 3949556, 3949616, 4020634	Temp / Hum in	23°C / 39%rh
EUT Serial	Prototype	Temp / Hum out	N/A
EUT Config.	Y-Axis, 12dBm, 1Mbps	Line AC	120Vac 60Hz
Standard	CFR47 Part 15 Subpart C	RBW / VBW	1MHz / 3MHz
Dist/Ant Used	3m - EMCO3115 / 1m - RA42-K-F-4B-C	Performed by	Jeremy Luong

Above 1GHz Plots for Transmit Mode at 2412MHz, 802.11b 1Mbit/s

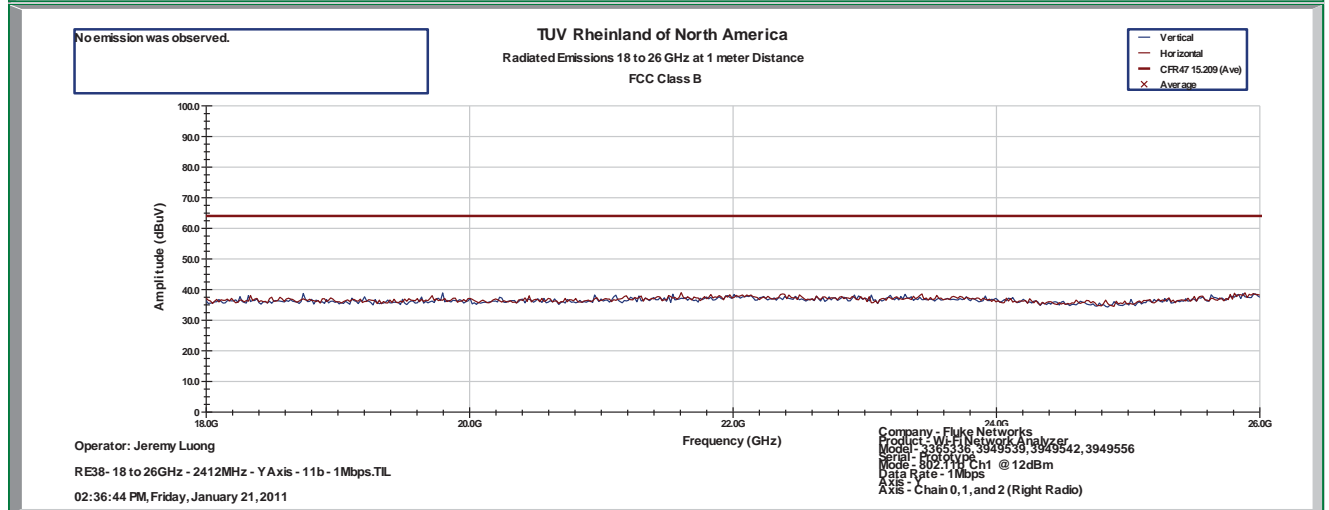
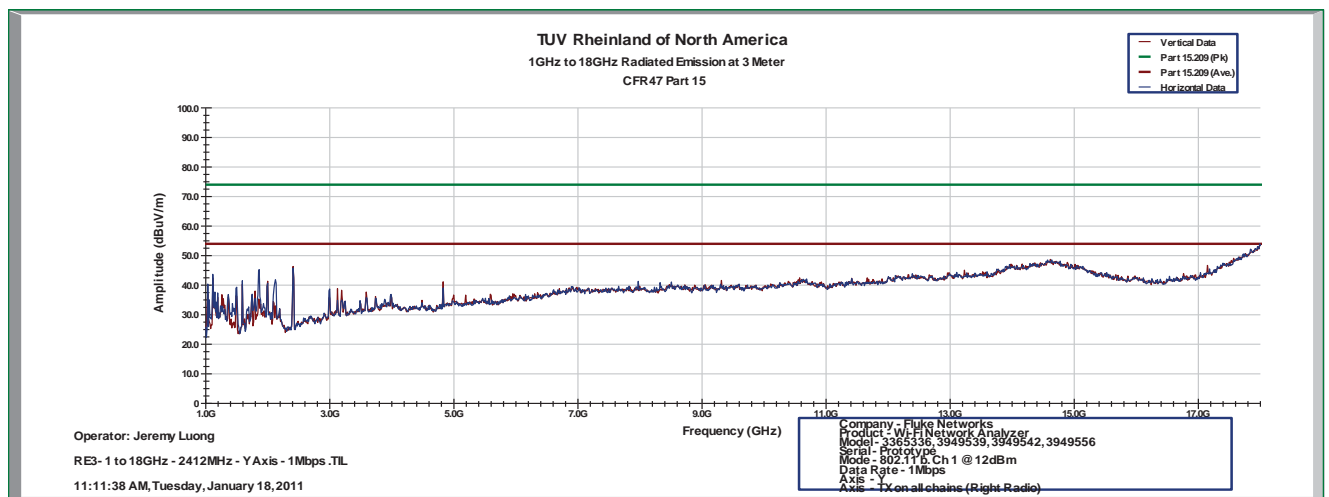

Notes: Limit was extrapolated to 1m distance for 18GHz – 25 GHz range.
 1GHz – 25 GHz Setting: RBW = 1MHz/ VBW = 3MHz

SOP 1 Radiated Emissions

Tracking # 31053887.001 Page 3 of 32

EUT Name	OPTIVIEW XG, OPVXG, OPTIVIEW XG-10G, OPVXG-10G, OPVXGPRO, OPVXG-EXPT, OPTIVIEW XG-LAN, OPVXG-LAN, OPVXG-LAN-10G, OPTIVIEW XG WLAN, OPVXG-WLAN	Date	January 18, 2011
EUT Model	3365336, 3949539, 3949542, 3949556, 3949616, 4020634	Temp / Hum in	23°C / 39%rh
EUT Serial	Prototype	Temp / Hum out	N/A
EUT Config.	Y-Axis, 12dBm, 1Mbps	Line AC	120Vac 60Hz
Standard	CFR47 Part 15 Subpart C	RBW / VBW	1MHz / 3MHz
Dist/Ant Used	3m - EMCO3115 / 1m - RA42-K-F-4B-C	Performed by	Jeremy Luong

Above 1GHz Plots for Transmit Mode at 2437MHz, 802.11b 1Mbit/s

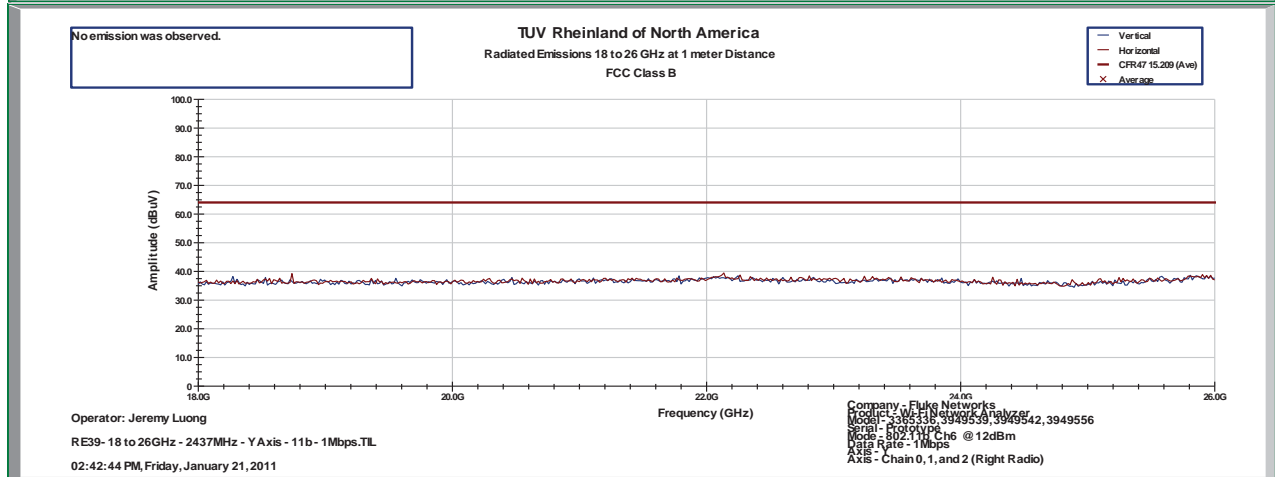
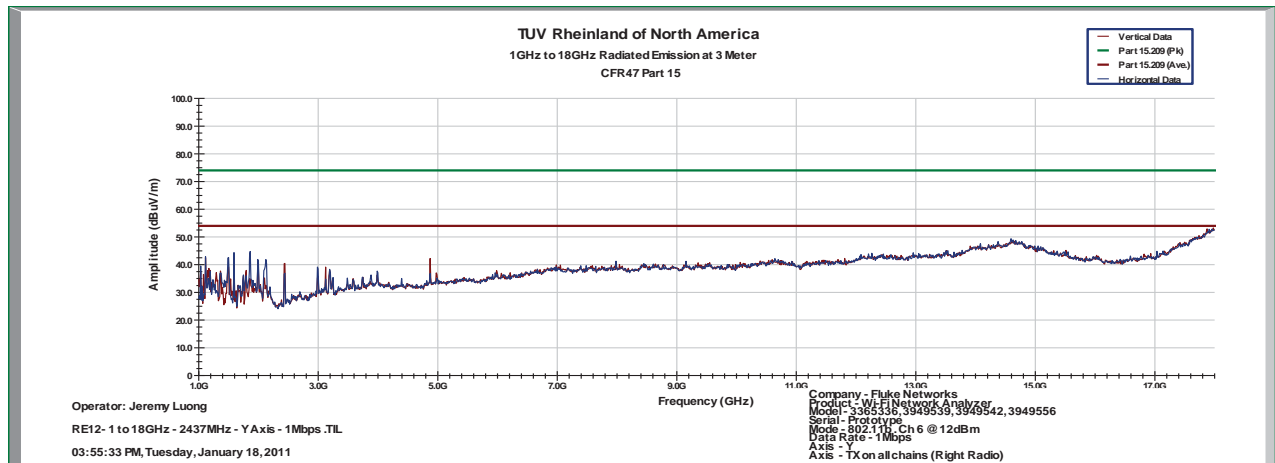

Notes: Limit was extrapolated to 1m distance for 18GHz – 25 GHz range.
 1GHz – 25 GHz Setting: RBW = 1MHz/ VBW = 3MHz

SOP 1 Radiated Emissions

Tracking # 31053887.001 Page 4 of 32

EUT Name	OPTIVIEW XG, OPVXG, OPTIVIEW XG-10G, OPVXG-10G, OPVXGPRO, OPVXG-EXPT, OPTIVIEW XG-LAN, OPVXG-LAN, OPVXG-LAN-10G, OPTIVIEW XG WLAN, OPVXG-WLAN	Date	January 18, 2011
EUT Model	3365336, 3949539, 3949542, 3949556, 3949616, 4020634	Temp / Hum in	23°C / 40%rh
EUT Serial	Prototype	Temp / Hum out	N/A
EUT Config.	Y-Axis, 12dBm, 1Mbps	Line AC	120Vac 60Hz
Standard	CFR47 Part 15 Subpart C	RBW / VBW	1MHz / 3MHz
Dist/Ant Used	3m - EMCO3115 / 1m - RA42-K-F-4B-C	Performed by	Jeremy Luong

Above 1GHz Plots for Transmit Mode at 2462MHz, 802.11b 1Mbit/s

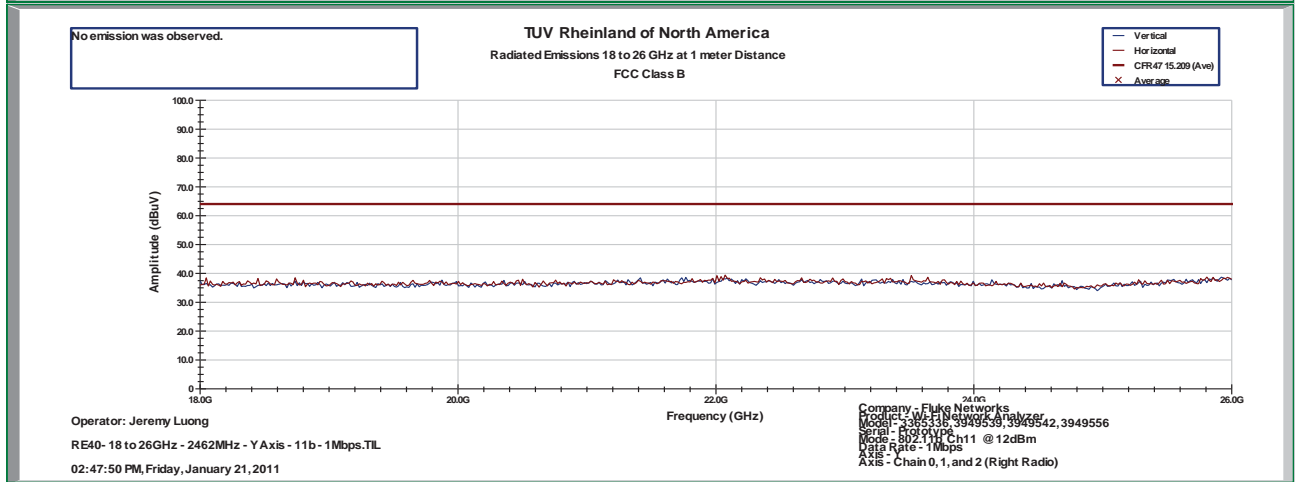
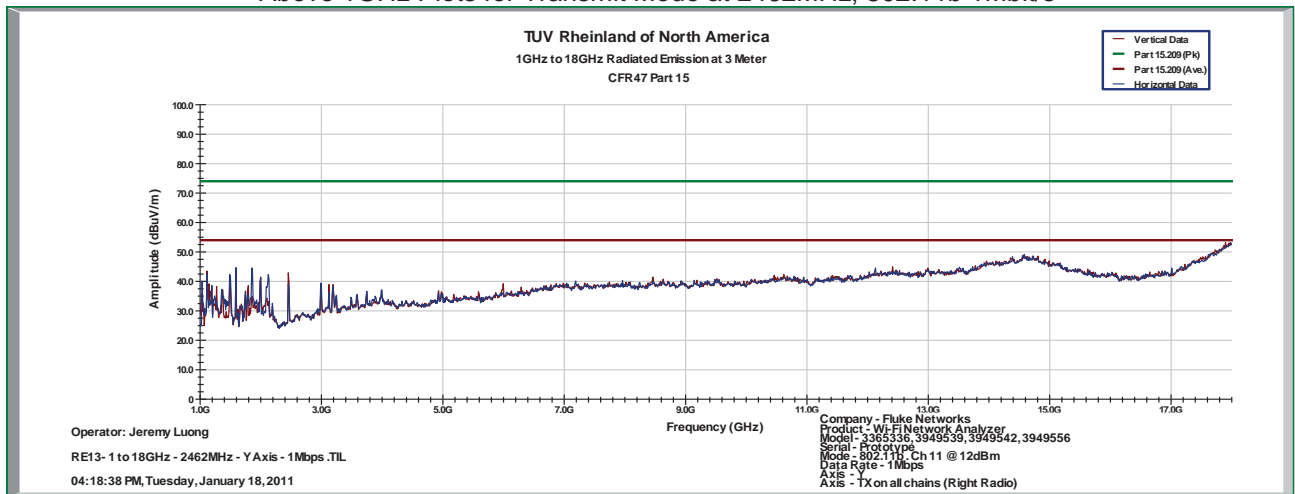

Notes: Limit was extrapolated to 1m distance for 18GHz – 25 GHz range.
 1GHz – 25 GHz Setting: RBW = 1MHz/ VBW = 3MHz

SOP 1 Radiated Emissions											Tracking # 31053887.001 Page 5 of 32	
EUT Name		OPTIVIEW XG, OPVXG, OPTIVIEW XG-10G, OPVXG-10G, OPVXGPRO, OPVXG-EXPT, OPTIVIEW XG-LAN, OPVXG-LAN, OPVXG-LAN-10G, OPTIVIEW XG WLAN, OPVXG-WLAN						Date		January 18, 2011		
EUT Model		3365336, 3949539, 3949542, 3949556, 3949616, 4020634						Temp / Hum in		23°C / 39%rh		
EUT Serial		Prototype						Temp / Hum out		N/A		
EUT Config.		Y-Axis, 12dBm, 802.11g at 6Mbps						Line AC / Freq		120Vac/60Hz		
Standard		CFR47 Part 15 Subpart C						RBW / VBW		1 MHz/ 3 MHz		
Dist/Ant Used		3m / EMCO3115 / 1m - RA42-K-F-4B-C						Performed by		Jeremy Luong		
Emission Freq (MHz)	ANT Polar (H/V)	ANT Pos (cm)	Table Pos (deg)	FIM (Pk) (dBuV/m)	FIM Ave (dBuV/m)	Total CF (dBuV)	E-Field Ave (dBuV/m)	Spec Limit (dBuV/m)	Spec Margin (dB)	Type		
Transmitted Data at 2412MHz												
1861.19	H	204	186	55.70	42.28	-4.94	37.34	53.98	-16.64	Spurious		
4820.87	V	231	60	45.30	28.22	2.40	30.62	53.98	-23.36	Harmonic		
4824.66	H	204	94	40.45	26.44	2.42	28.86	53.98	-25.12	Harmonic		
Transmitted Data at 2437MHz												
1595.37	H	135	151	58.88	39.84	-6.83	33.01	53.98	-20.97	Spurious		
1861.15	H	139	245	55.41	41.57	-4.94	36.63	53.98	-17.35	Spurious		
4868.41	H	143	339	44.08	26.25	2.53	28.78	53.98	-25.20	Harmonic		
4870.24	V	109	27	46.02	26.84	2.53	29.36	53.98	-24.62	Harmonic		
Transmitted Data at 2462MHz												
1861.17	H	101	173	55.38	41.96	-4.94	37.02	53.98	-16.96	Spurious		
4919.47	H	190	324	41.80	26.38	2.58	28.96	53.98	-25.02	Harmonic		
4921.00	V	210	378	45.35	28.18	2.58	30.77	53.98	-23.21	Harmonic		
Spec Margin = E-Field QP - Limit, E-Field QP = FIM QP+ Total CF ± Uncertainty												
Total CF= Amp Gain + Cable Loss + ANT Factor												
Combined Standard Uncertainty $u_c(y) = \pm 3.2$ dB Expanded Uncertainty $U = k u_c(y)$ $k = 2$ for 95% confidence												
Notes: Worst case was observed on Y-axis, 6Mbps.												
The output Chain 1 of the right radio was transmitted at +12dBm												

SOP 1 Radiated Emissions

Tracking # 31053887.001 Page 6 of 32

EUT Name	OPTIVIEW XG, OPVXG, OPTIVIEW XG-10G, OPVXG-10G, OPVXGPRO, OPVXG-EXPT, OPTIVIEW XG-LAN, OPVXG-LAN, OPVXG-LAN-10G, OPTIVIEW XG WLAN, OPVXG-WLAN	Date	January 18, 2011
EUT Model	3365336, 3949539, 3949542, 3949556, 3949616, 4020634	Temp / Hum in	23°C / 39%rh
EUT Serial	Prototype	Temp / Hum out	N/A
EUT Config.	Y-Axis, 12dBm, 802.11g at 6Mbps	Line AC	120Vac 60Hz
Standard	CFR47 Part 15 Subpart C	RBW / VBW	1MHz / 3MHz
Dist/Ant Used	3m - EMCO3115 / 1m - RA42-K-F-4B-C	Performed by	Jeremy Luong

Above 1GHz Plots for Transmit Mode at 2412MHz, 802.11g 6Mbit/s

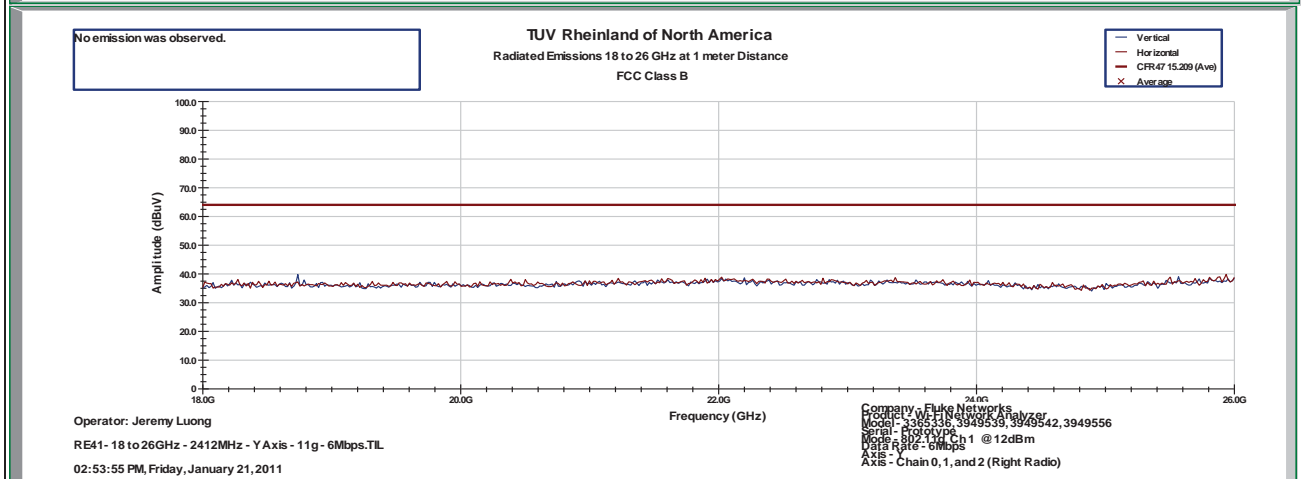
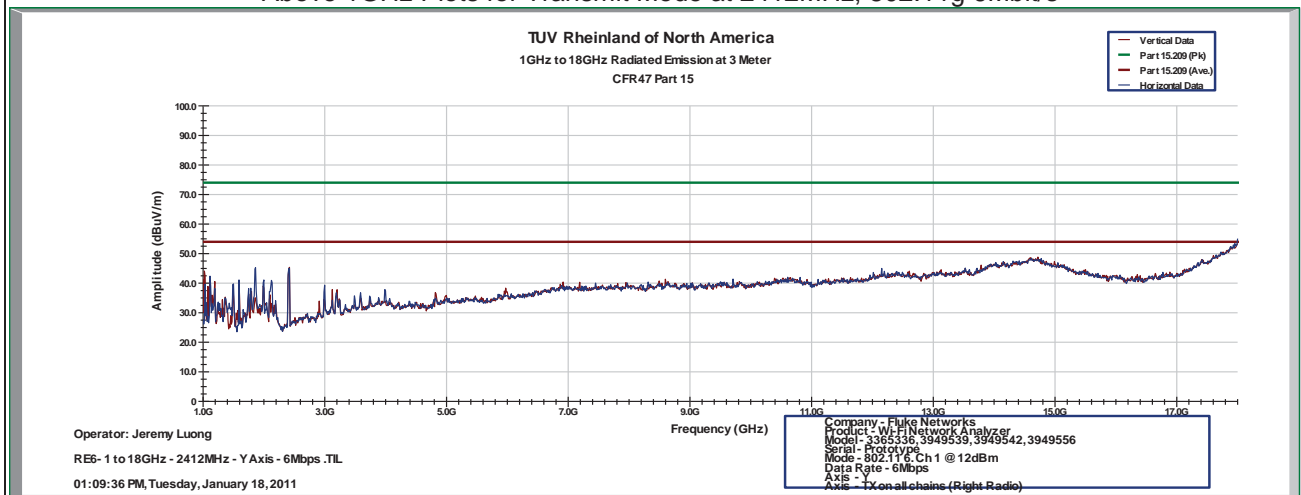

Notes: Limit was extrapolated to 1m distance for 18GHz – 25 GHz range.
 1GHz – 25 GHz Setting: RBW = 1MHz/ VBW = 3MHz

SOP 1 Radiated Emissions

Tracking # 31053887.001 Page 7 of 32

EUT Name	OPTIVIEW XG, OPVXG, OPTIVIEW XG-10G, OPVXG-10G, OPVXGPRO, OPVXG-EXPT, OPTIVIEW XG-LAN, OPVXG-LAN, OPVXG-LAN-10G, OPTIVIEW XG WLAN, OPVXG-WLAN	Date	January 18, 2011
EUT Model	3365336, 3949539, 3949542, 3949556, 3949616, 4020634	Temp / Hum in	23°C / 39%rh
EUT Serial	Prototype	Temp / Hum out	N/A
EUT Config.	Y-Axis, 12dBm, 802.11g at 6Mbps	Line AC	120Vac 60Hz
Standard	CFR47 Part 15 Subpart C	RBW / VBW	1MHz / 3MHz
Dist/Ant Used	3m - EMCO3115 / 1m - RA42-K-F-4B-C	Performed by	Jeremy Luong

Above 1GHz Plots for Transmit Mode at 2437MHz, 802.11g 6Mbit/s

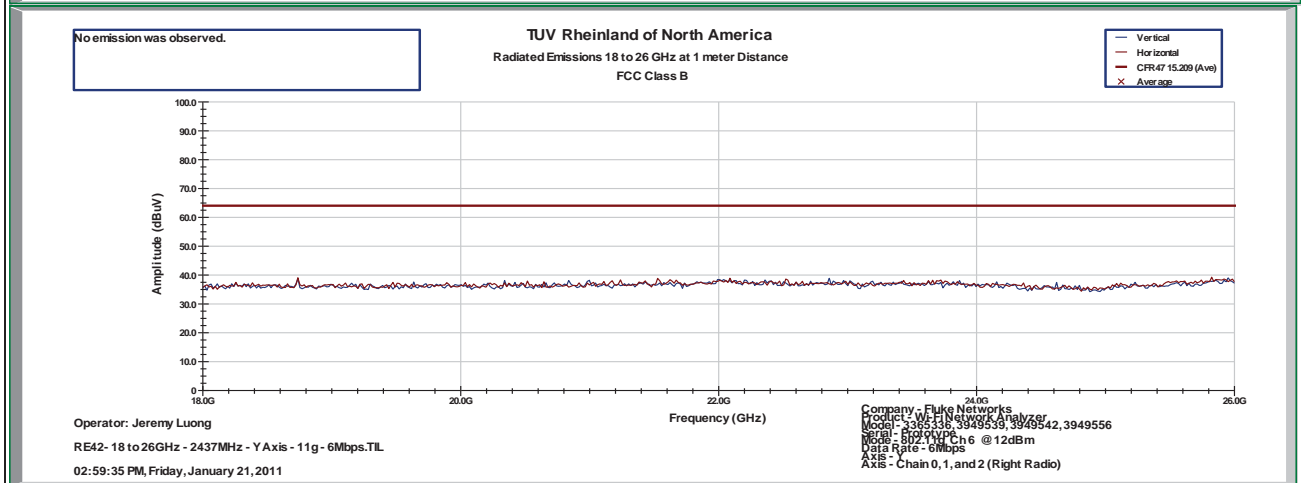
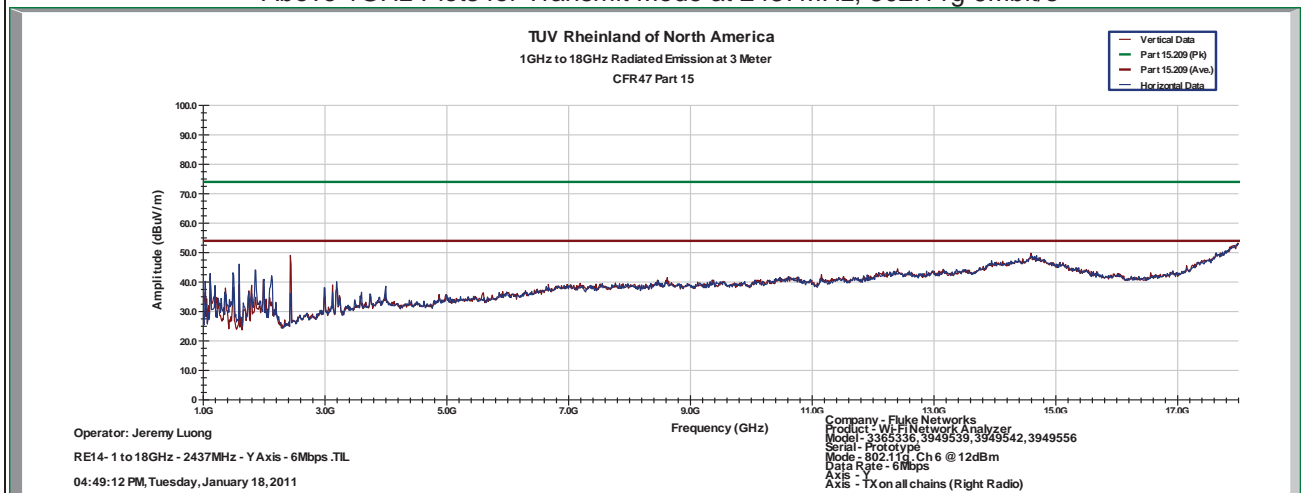

Notes: Limit was extrapolated to 1m distance for 18GHz – 25 GHz range.
 1GHz – 25 GHz Setting: RBW = 1MHz/ VBW = 3MHz

SOP 1 Radiated Emissions

Tracking # 31053887.001 Page 8 of 32

EUT Name	OPTIVIEW XG, OPVXG, OPTIVIEW XG-10G, OPVXG-10G, OPVXGPRO, OPVXG-EXPT, OPTIVIEW XG-LAN, OPVXG-LAN, OPVXG-LAN-10G, OPTIVIEW XG WLAN, OPVXG-WLAN	Date	January 20, 2011
EUT Model	3365336, 3949539, 3949542, 3949556, 3949616, 4020634	Temp / Hum in	23°C / 40%rh
EUT Serial	Prototype	Temp / Hum out	N/A
EUT Config.	Y-Axis, 12dBm, 802.11g at 6Mbps	Line AC	120Vac 60Hz
Standard	CFR47 Part 15 Subpart C	RBW / VBW	1MHz / 3MHz
Dist/Ant Used	3m - EMCO3115 / 1m - RA42-K-F-4B-C	Performed by	Jeremy Luong

Above 1GHz Plots for Transmit Mode at 2462MHz, 802.11b 6Mbit/s

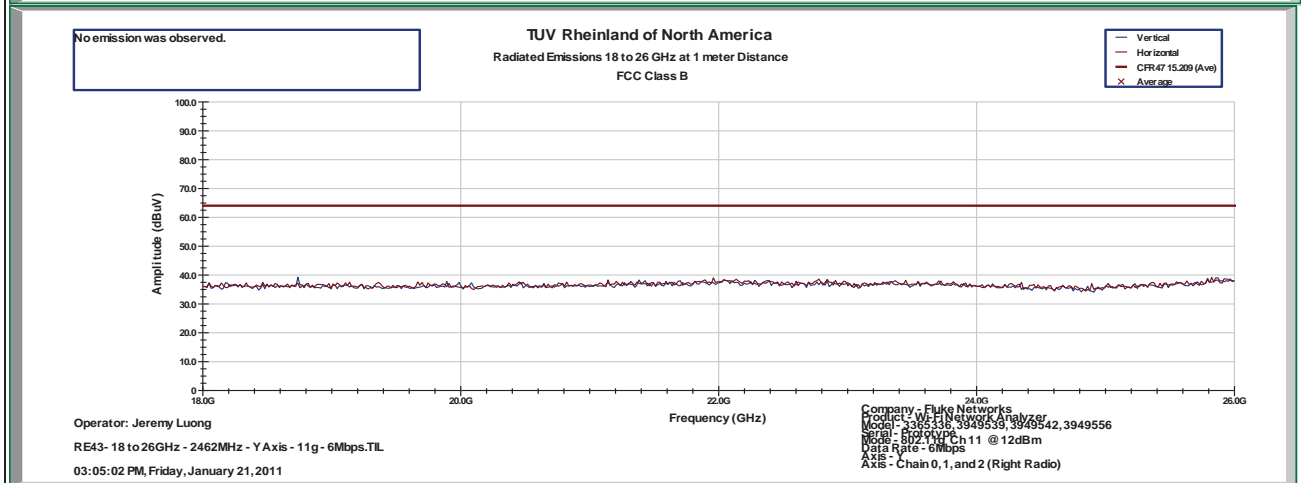
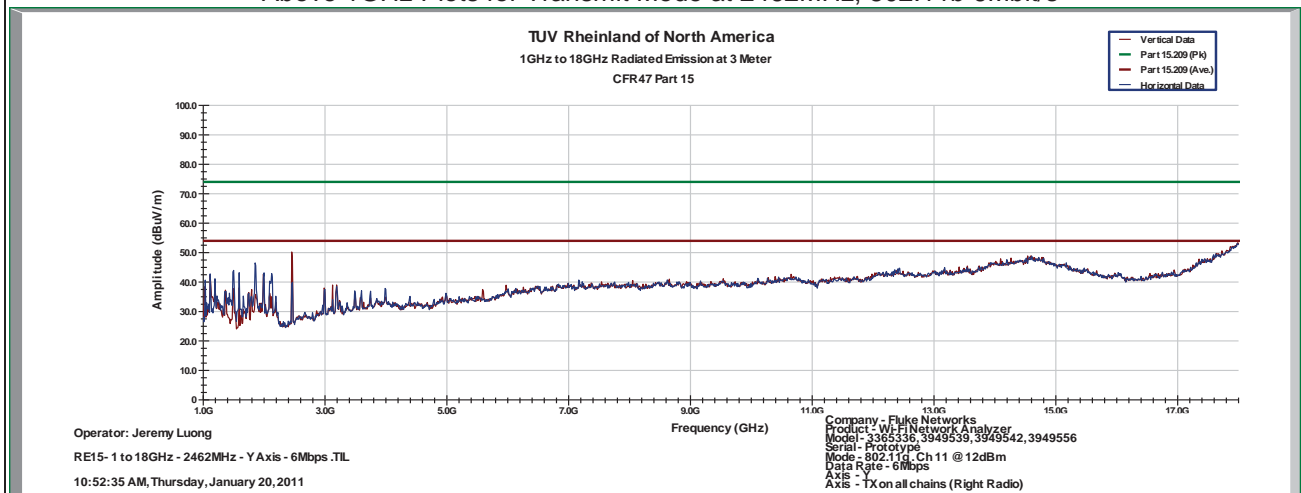

Notes: Limit was extrapolated to 1m distance for 18GHz – 25 GHz range.
 1GHz – 25 GHz Setting: RBW = 1MHz/ VBW = 3MHz

SOP 1 Radiated Emissions											Tracking # 31053887.001 Page 9 of 32	
EUT Name	OPTIVIEW XG, OPVXG, OPTIVIEW XG-10G, OPVXG-10G, OPVXGPRO, OPVXG-EXPT, OPTIVIEW XG-LAN, OPVXG-LAN, OPVXG-LAN-10G, OPTIVIEW XG WLAN, OPVXG-WLAN						Date	January 20, 2011				
EUT Model	3365336, 3949539, 3949542, 3949556, 3949616, 4020634						Temp / Hum in	23°C / 40%rh				
EUT Serial	Prototype						Temp / Hum out	N/A				
EUT Config.	Y-Axis, 12.5dBm, 802.11n HT20 at 6.5Mbps						Line AC / Freq	120Vac/60Hz				
Standard	CFR47 Part 15 Subpart C						RBW / VBW	1 MHz/ 3 MHz				
Dist/Ant Used	3m / EMCO3115 / 1m - RA42-K-F-4B-C						Performed by	Jeremy Luong				
Emission Freq (MHz)	ANT Polar (H/V)	ANT Pos (cm)	Table Pos (deg)	FIM (Pk) (dBuV/m)	FIM Ave (dBuV/m)	Total CF (dBuV)	E-Field Ave (dBuV/m)	Spec Limit (dBuV/m)	Spec Margin (dB)	Type		
Transmitted Data at 2412MHz												
1861.11	H	100	174	55.35	41.96	-4.94	37.02	53.98	-16.96	Spurious		
4823.10	V	205	128	39.80	26.20	2.41	28.61	53.98	-25.37	Harmonic		
4824.00	H	100	117	40.40	23.57	2.42	25.99	53.98	-27.99	Harmonic		
Transmitted Data at 2437MHz												
1861.23	H	99	203	56.63	42.95	-4.94	38.01	53.98	-15.97	Spurious		
4874.00	H	162	155	39.11	24.94	2.52	27.46	53.98	-26.52	Harmonic		
4874.00	V	173	195	37.78	24.84	2.52	27.36	53.98	-26.62	Harmonic		
Transmitted Data at 2462MHz												
1861.15	H	99	166	55.72	41.96	-4.94	37.02	53.98	-16.96	Spurious		
4915.97	H	161	131	39.72	25.13	2.56	27.69	53.98	-26.29	Harmonic		
4923.67	V	160	63	38.42	23.98	2.60	26.58	53.98	-27.40	Harmonic		
Spec Margin = E-Field QP - Limit, E-Field QP = FIM QP+ Total CF ± Uncertainty												
Total CF= Amp Gain + Cable Loss + ANT Factor												
Combined Standard Uncertainty $u_c(y) = \pm 3.2$ dB Expanded Uncertainty $U = k u_c(y)$ $k = 2$ for 95% confidence												
Notes: Worst case was observed on Y-axis, 6.5Mbps. RF power transmitted at Chains 1 of the right radio.												

SOP 1 Radiated Emissions

Tracking # 31053887.001 Page 10 of 32

EUT Name	OPTIVIEW XG, OPVXG, OPTIVIEW XG-10G, OPVXG-10G, OPVXGPRO, OPVXG-EXPT, OPTIVIEW XG-LAN, OPVXG-LAN, OPVXG-LAN-10G, OPTIVIEW XG WLAN, OPVXG-WLAN	Date	January 20, 2011
EUT Model	3365336, 3949539, 3949542, 3949556, 3949616, 4020634	Temp / Hum in	23°C / 40%rh
EUT Serial	Prototype	Temp / Hum out	N/A
EUT Config.	Y-Axis, 12.5dBm, 802.11n HT20 at 6.5Mbps	Line AC	120Vac 60Hz
Standard	CFR47 Part 15 Subpart C	RBW / VBW	1MHz / 3MHz
Dist/Ant Used	3m - EMCO3115 / 1m - RA42-K-F-4B-C	Performed by	Jeremy Luong

Above 1GHz Plots for Transmit Mode at 2412MHz

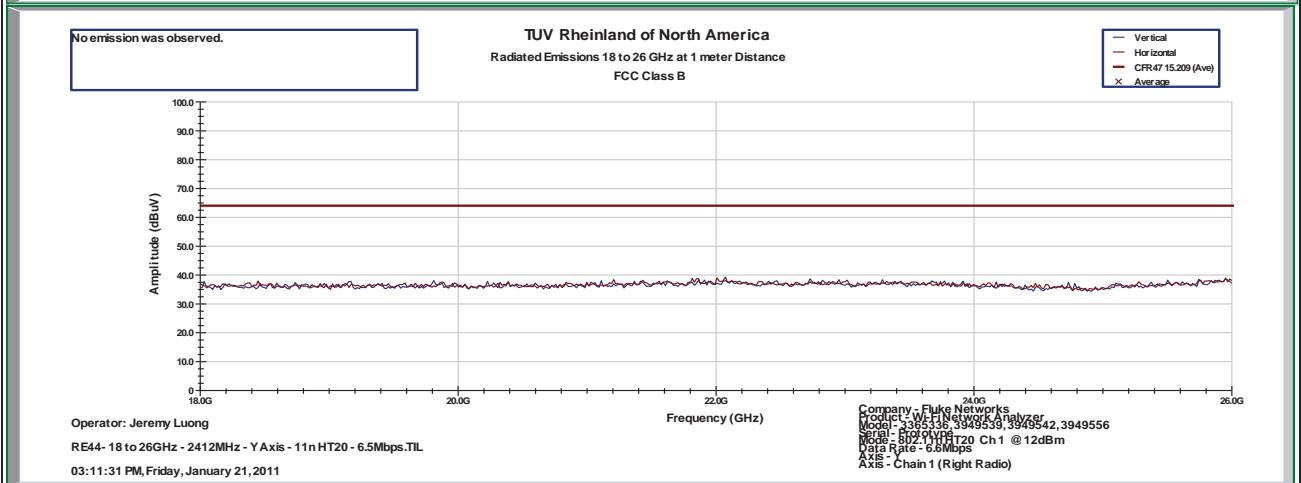
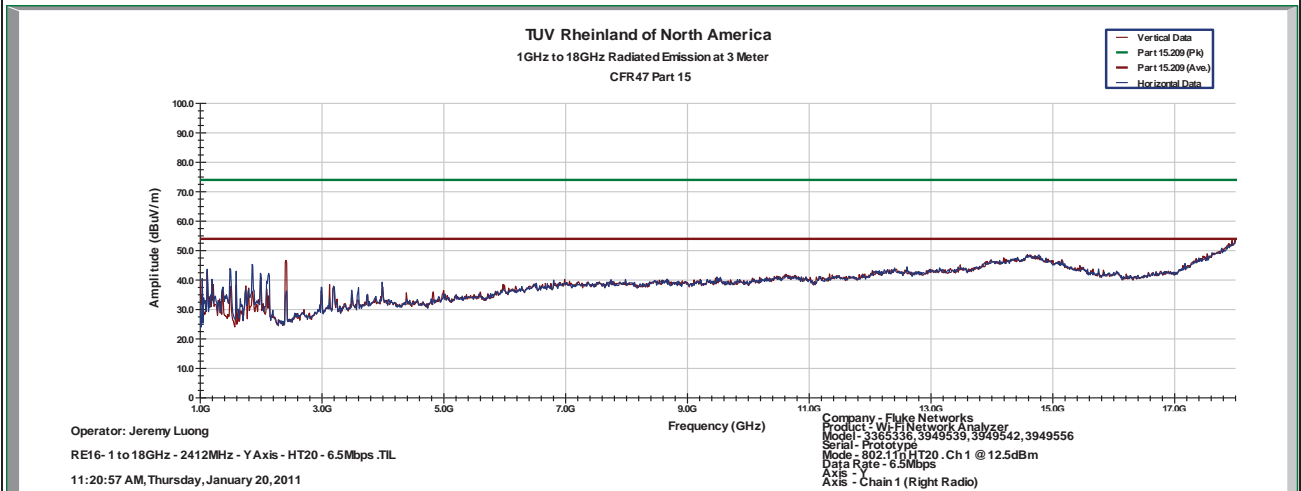

Notes: Limit was extrapolated to 1m distance for 18GHz – 25 GHz range.
 1GHz – 25 GHz Setting: RBW = 1MHz/ VBW = 3MHz

SOP 1 Radiated Emissions

Tracking # 31053887.001 Page 11 of 32

EUT Name	OPTIVIEW XG, OPVXG, OPTIVIEW XG-10G, OPVXG-10G, OPVXGPRO, OPVXG-EXPT, OPTIVIEW XG-LAN, OPVXG-LAN, OPVXG-LAN-10G, OPTIVIEW XG WLAN, OPVXG-WLAN	Date	January 20, 2011
EUT Model	3365336, 3949539, 3949542, 3949556, 3949616, 4020634	Temp / Hum in	23°C / 40%rh
EUT Serial	Prototype	Temp / Hum out	N/A
EUT Config.	Y-Axis, 12.5dBm, 802.11n HT20 at 6.5Mbps	Line AC	120Vac 60Hz
Standard	CFR47 Part 15 Subpart C	RBW / VBW	1MHz / 3MHz
Dist/Ant Used	3m - EMCO3115 / 1m - RA42-K-F-4B-C	Performed by	Jeremy Luong

Above 1GHz Plots for Transmit Mode at 2437MHz

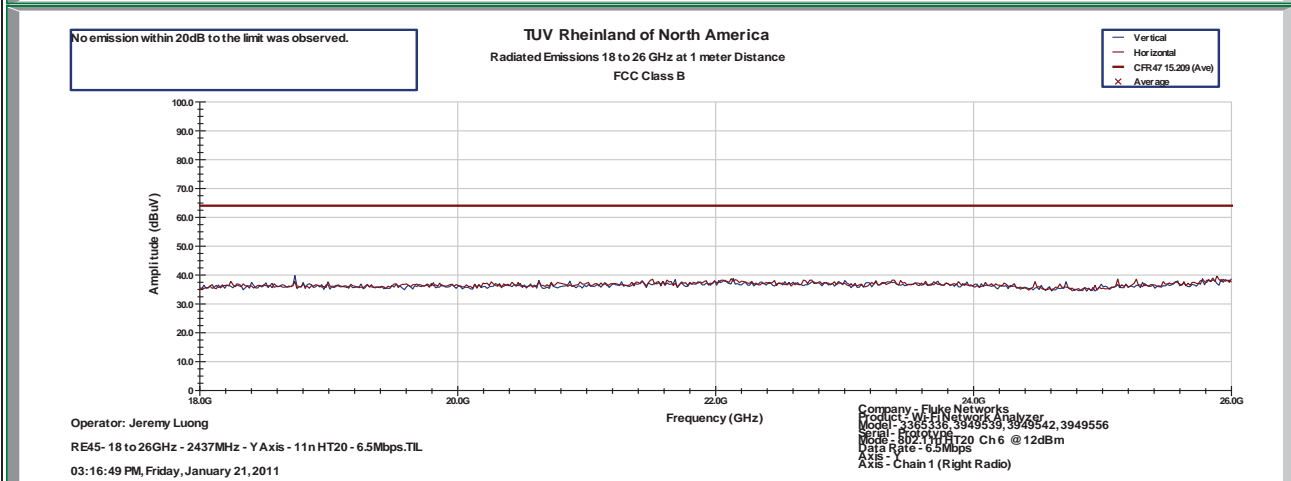
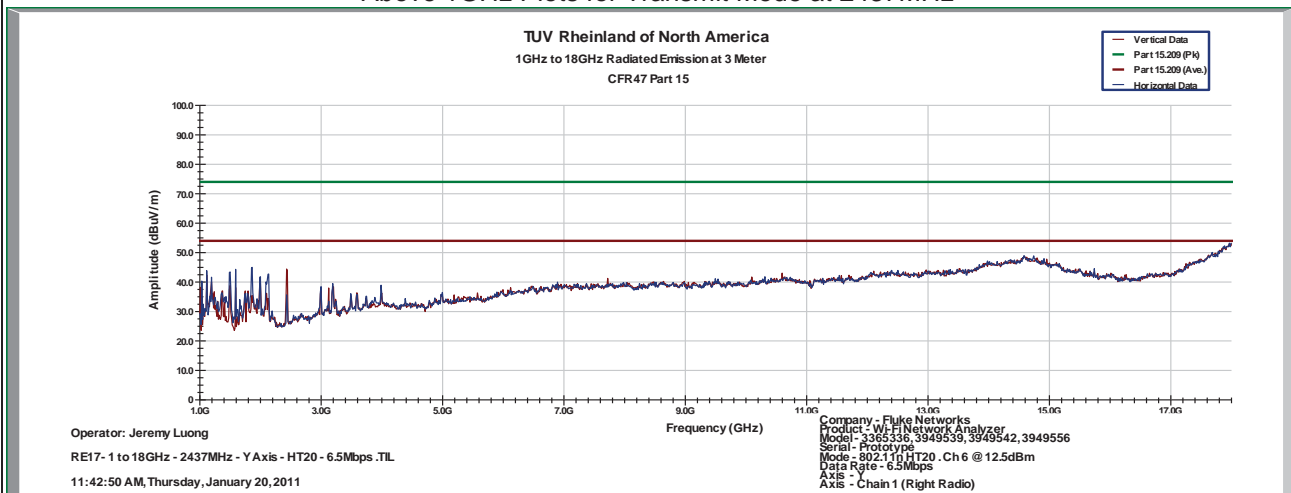

Notes: Limit was extrapolated to 1m distance for 18GHz – 25 GHz range.
 1GHz – 25 GHz Setting: RBW = 1MHz/ VBW = 3MHz

SOP 1 Radiated Emissions

Tracking # 31053887.001 Page 12 of 32

EUT Name	OPTIVIEW XG, OPVXG, OPTIVIEW XG-10G, OPVXG-10G, OPVXGPRO, OPVXG-EXPT, OPTIVIEW XG-LAN, OPVXG-LAN, OPVXG-LAN-10G, OPTIVIEW XG WLAN, OPVXG-WLAN	Date	January 20, 2011
EUT Model	3365336, 3949539, 3949542, 3949556, 3949616, 4020634	Temp / Hum in	23°C / 40%rh
EUT Serial	Prototype	Temp / Hum out	N/A
EUT Config.	Y-Axis, 12.5dBm, 802.11n HT20 at 6.5Mbps	Line AC	120Vac 60Hz
Standard	CFR47 Part 15 Subpart C	RBW / VBW	1MHz / 3MHz
Dist/Ant Used	3m - EMCO3115 / 1m - RA42-K-F-4B-C	Performed by	Jeremy Luong

Above 1GHz Plots for Transmit Mode at 2462MHz

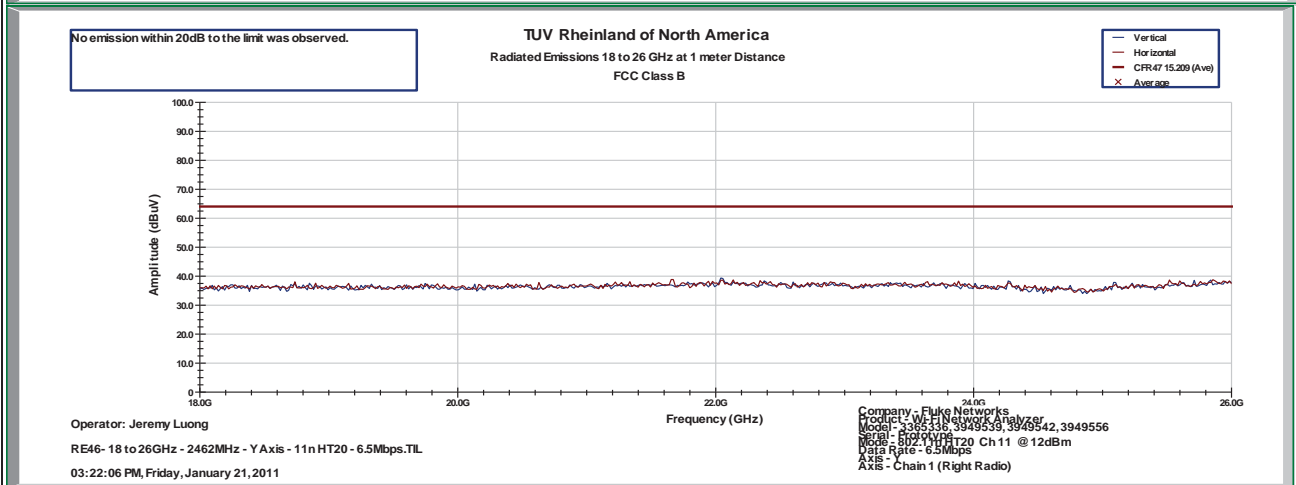
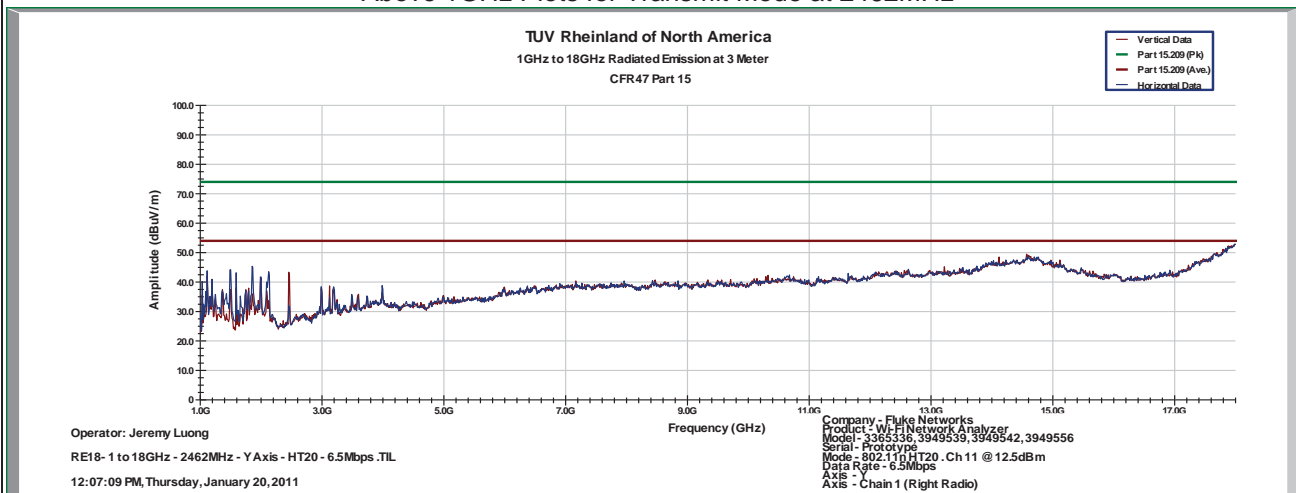

Notes: Limit was extrapolated to 1m distance for 18GHz – 25 GHz range.
 1GHz – 25 GHz Setting: RBW = 1MHz/ VBW = 3MHz

SOP 1 Radiated Emissions											Tracking # 31053887.001 Page 13 of 32	
EUT Name		OPTIVIEW XG, OPVXG, OPTIVIEW XG-10G, OPVXG-10G, OPVXGPRO, OPVXG-EXPT, OPTIVIEW XG-LAN, OPVXG-LAN, OPVXG-LAN-10G, OPTIVIEW XG WLAN, OPVXG-WLAN						Date		January 20, 2011		
EUT Model		3365336, 3949539, 3949542, 3949556, 3949616, 4020634						Temp / Hum in		23°C / 40%rh		
EUT Serial		Prototype						Temp / Hum out		N/A		
EUT Config.		Y-Axis, 12.5dBm, 802.11n HT20 at 13Mbps						Line AC / Freq		120Vac/60Hz		
Standard		CFR47 Part 15 Subpart C						RBW / VBW		1 MHz/ 3 MHz		
Dist/Ant Used		3m / EMCO3115 / 1m - RA42-K-F-4B-C						Performed by		Jeremy Luong		
Emission Freq (MHz)	ANT Polar (H/V)	ANT Pos (cm)	Table Pos (deg)	FIM (Pk) (dBuV/m)	FIM Ave (dBuV/m)	Total CF (dBuV)	E-Field Ave (dBuV/m)	Spec Limit (dBuV/m)	Spec Margin (dB)	Type		
Transmitted Data at 2412MHz												
1861.15	H	142	196	56.26	42.50	-4.94	37.56	53.98	-16.42	Spurious		
4822.95	V	202	97	43.06	27.23	2.41	29.64	53.98	-24.34	Harmonic		
4823.67	H	142	-33	39.57	25.08	2.42	27.50	53.98	-26.48	Harmonic		
Transmitted Data at 2437MHz												
1861.09	H	201	167	54.60	41.51	-4.94	36.57	53.98	-17.41	Spurious		
4873.85	H	141	342	40.57	25.92	2.52	28.44	53.98	-25.54	Harmonic		
4875.68	V	197	22	43.56	25.43	2.52	27.95	53.98	-26.03	Harmonic		
Transmitted Data at 2462MHz												
1860.97	H	143	207	56.76	43.02	-4.94	38.08	53.98	-15.90	Spurious		
4922.38	H	133	132	40.96	25.12	2.59	27.71	53.98	-26.27	Harmonic		
4924.12	V	129	358	42.65	25.67	2.60	28.27	53.98	-25.71	Harmonic		
Spec Margin = E-Field QP - Limit, E-Field QP = FIM QP+ Total CF ± Uncertainty												
Total CF= Amp Gain + Cable Loss + ANT Factor												
Combined Standard Uncertainty $u_c(y) = \pm 3.2$ dB Expanded Uncertainty $U = k u_c(y)$ $k = 2$ for 95% confidence												
Notes: Worst case was observed on Y-axis, 13Mbps. RF power transmitted at Chains 0 and 1.												

SOP 1 Radiated Emissions

Tracking # 31053887.001 Page 14 of 32

EUT Name	OPTIVIEW XG, OPVXG, OPTIVIEW XG-10G, OPVXG-10G, OPVXGPRO, OPVXG-EXPT, OPTIVIEW XG-LAN, OPVXG-LAN, OPVXG-LAN-10G, OPTIVIEW XG WLAN, OPVXG-WLAN	Date	January 20, 2011
EUT Model	3365336, 3949539, 3949542, 3949556, 3949616, 4020634	Temp / Hum in	23°C / 40%rh
EUT Serial	Prototype	Temp / Hum out	N/A
EUT Config.	Y-Axis, 12.5dBm, 802.11n HT20 at 13Mbps	Line AC	120Vac 60Hz
Standard	CFR47 Part 15 Subpart C	RBW / VBW	1MHz / 3MHz
Dist/Ant Used	3m - EMCO3115 / 1m - RA42-K-F-4B-C	Performed by	Jeremy Luong

Above 1GHz Plots for Transmit Mode at 2412MHz

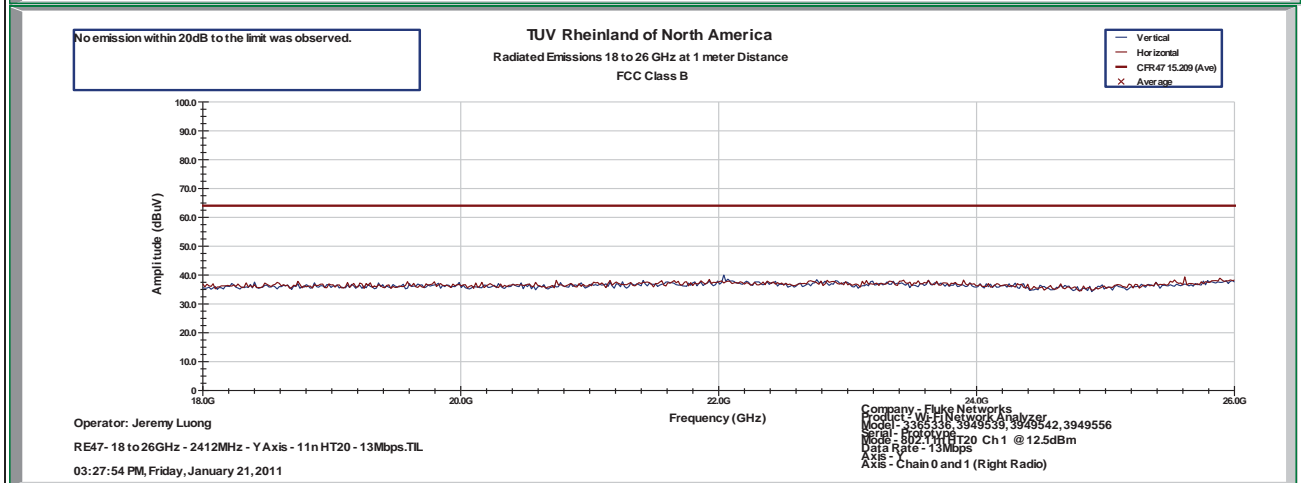
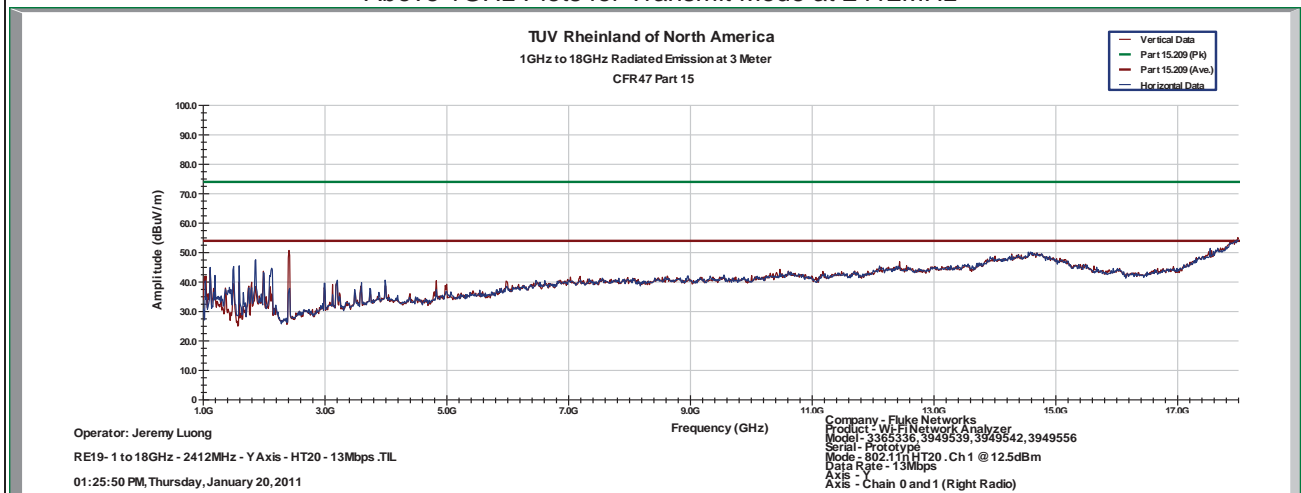

Notes: Limit was extrapolated to 1m distance for 18GHz – 25 GHz range.
 1GHz – 25 GHz Setting: RBW = 1MHz/ VBW = 3MHz

SOP 1 Radiated Emissions

Tracking # 31053887.001 Page 15 of 32

EUT Name	OPTIVIEW XG, OPVXG, OPTIVIEW XG-10G, OPVXG-10G, OPVXGPRO, OPVXG-EXPT, OPTIVIEW XG-LAN, OPVXG-LAN, OPVXG-LAN-10G, OPTIVIEW XG WLAN, OPVXG-WLAN	Date	January 20, 2011
EUT Model	3365336, 3949539, 3949542, 3949556, 3949616, 4020634	Temp / Hum in	23°C / 40%rh
EUT Serial	Prototype	Temp / Hum out	N/A
EUT Config.	Y-Axis, 12.5dBm, 802.11n HT20 at 13Mbps	Line AC	120Vac 60Hz
Standard	CFR47 Part 15 Subpart C	RBW / VBW	1MHz / 3MHz
Dist/Ant Used	3m - EMCO3115 / 1m - RA42-K-F-4B-C	Performed by	Jeremy Luong

Above 1GHz Plots for Transmit Mode at 2437MHz

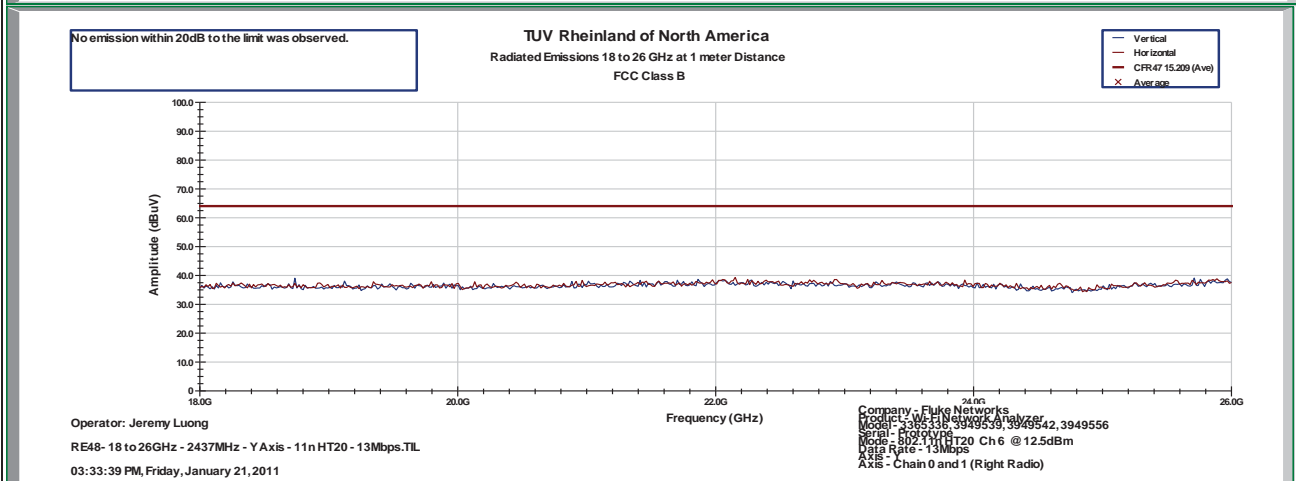
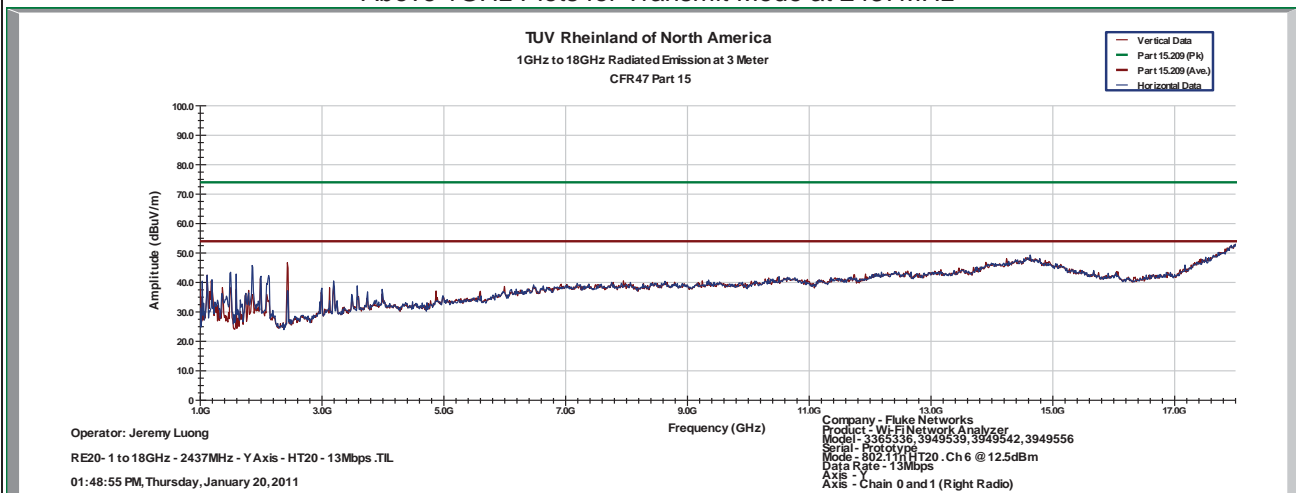

Notes: Limit was extrapolated to 1m distance for 18GHz – 25 GHz range.
 1GHz – 25 GHz Setting: RBW = 1MHz/ VBW = 3MHz

SOP 1 Radiated Emissions

Tracking # 31053887.001 Page 16 of 32

EUT Name	OPTIVIEW XG, OPVXG, OPTIVIEW XG-10G, OPVXG-10G, OPVXGPRO, OPVXG-EXPT, OPTIVIEW XG-LAN, OPVXG-LAN, OPVXG-LAN-10G, OPTIVIEW XG WLAN, OPVXG-WLAN	Date	January 20, 2011
EUT Model	3365336, 3949539, 3949542, 3949556, 3949616, 4020634	Temp / Hum in	23°C / 40%rh
EUT Serial	Prototype	Temp / Hum out	N/A
EUT Config.	Y-Axis, 12.5dBm, 802.11n HT20 at 13Mbps	Line AC	120Vac 60Hz
Standard	CFR47 Part 15 Subpart C	RBW / VBW	1MHz / 3MHz
Dist/Ant Used	3m - EMCO3115 / 1m - RA42-K-F-4B-C	Performed by	Jeremy Luong

Above 1GHz Plots for Transmit Mode at 2462MHz

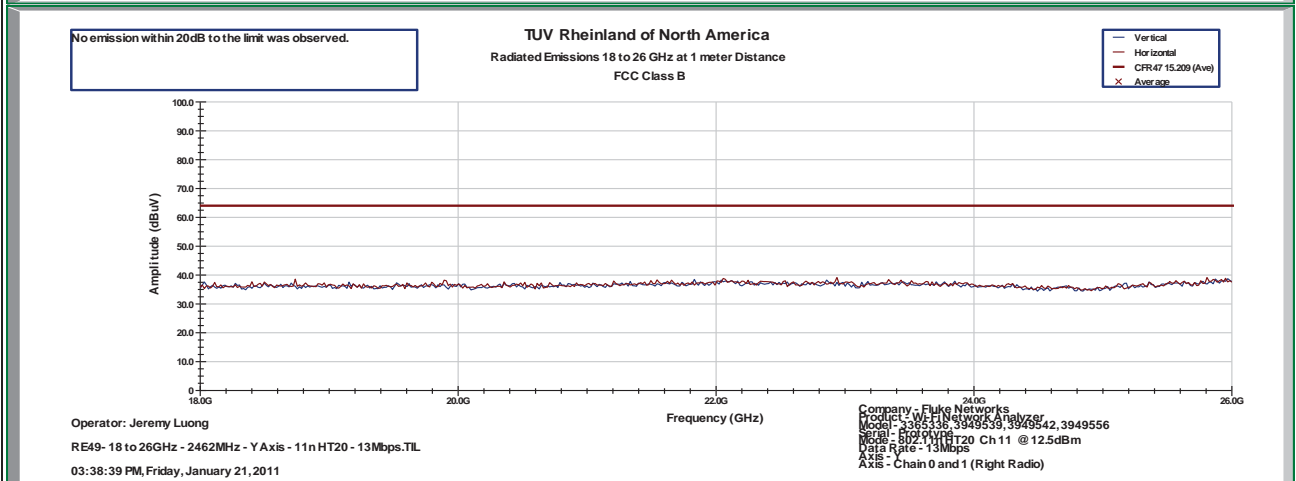
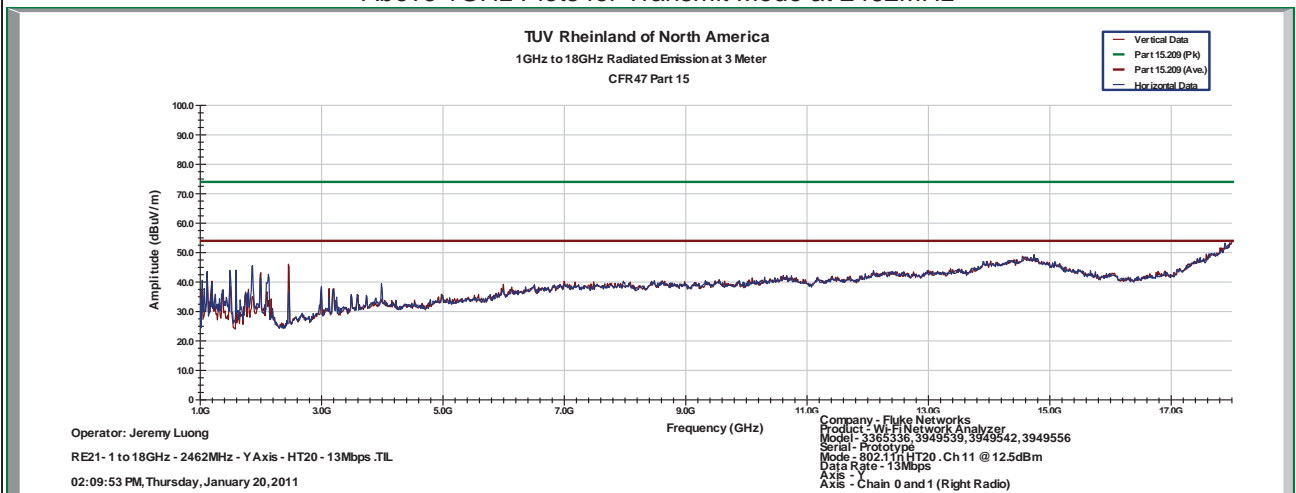

Notes: Limit was extrapolated to 1m distance for 18GHz – 25 GHz range.
 1GHz – 25 GHz Setting: RBW = 1MHz/ VBW = 3MHz

SOP 1 Radiated Emissions											Tracking # 31053887.001 Page 17 of 32
EUT Name		OPTIVIEW XG, OPVXG, OPTIVIEW XG-10G, OPVXG-10G, OPVXGPRO, OPVXG-EXPT, OPTIVIEW XG-LAN, OPVXG-LAN, OPVXG-LAN-10G, OPTIVIEW XG WLAN, OPVXG-WLAN					Date		January 20, 2011		
EUT Model		3365336, 3949539, 3949542, 3949556, 3949616, 4020634					Temp / Hum in		23°C / 40%rh		
EUT Serial		Prototype					Temp / Hum out		N/A		
EUT Config.		Y-Axis, 12.5dBm, 802.11n HT20 at 19.5Mbps					Line AC / Freq		120Vac/60Hz		
Standard		CFR47 Part 15 Subpart C					RBW / VBW		1 MHz/ 3 MHz		
Dist/Ant Used		3m / EMCO3115 / 1m - RA42-K-F-4B-C					Performed by		Jeremy Luong		
Emission Freq (MHz)	ANT Polar (H/V)	ANT Pos (cm)	Table Pos (deg)	FIM (Pk) (dBuV/m)	FIM Ave (dBuV/m)	Total CF (dBuV)	E-Field Ave (dBuV/m)	Spec Limit (dBuV/m)	Spec Margin (dB)	Type	
Transmitted Data at 2412MHz											
1861.21	H	198	168	54.97	41.88	-4.94	36.94	53.98	-17.04	Spurious	
4818.65	H	141	327	42.66	25.37	2.39	27.76	53.98	-26.22	Harmonic	
4820.87	V	211	90	44.37	27.69	2.40	30.09	53.98	-23.89	Harmonic	
Transmitted Data at 2437MHz											
1595.74	H	129	238	56.84	37.84	-6.83	31.01	53.98	-22.97	Spurious	
4867.48	H	148	-3	40.68	26.04	2.53	28.57	53.98	-25.41	Harmonic	
4872.92	V	198	376	44.66	26.41	2.52	28.93	53.98	-25.05	Harmonic	
Transmitted Data at 2462MHz											
1861.15	H	101	173	54.69	41.67	-4.94	36.73	53.98	-17.25	Spurious	
4926.46	H	97	-14	41.00	25.65	2.61	28.26	53.98	-25.72	Harmonic	
4929.47	V	112	4	44.54	27.26	2.63	29.89	53.98	-24.09	Harmonic	
Spec Margin = E-Field QP - Limit, E-Field QP = FIM QP+ Total CF ± Uncertainty											
Total CF= Amp Gain + Cable Loss + ANT Factor											
Combined Standard Uncertainty $u_c(y) = \pm 3.2$ dB Expanded Uncertainty $U = k u_c(y)$ $k = 2$ for 95% confidence											
Notes: Worst case was observed on Y-axis, 19.5Mbps. RF power transmitted at Chains 0, 1, and 2.											

SOP 1 Radiated Emissions

Tracking # 31053887.001 Page 18 of 32

EUT Name	OPTIVIEW XG, OPVXG, OPTIVIEW XG-10G, OPVXG-10G, OPVXGPRO, OPVXG-EXPT, OPTIVIEW XG-LAN, OPVXG-LAN, OPVXG-LAN-10G, OPTIVIEW XG WLAN, OPVXG-WLAN	Date	January 20, 2011
EUT Model	3365336, 3949539, 3949542, 3949556, 3949616, 4020634	Temp / Hum in	23°C / 40%rh
EUT Serial	Prototype	Temp / Hum out	N/A
EUT Config.	Y-Axis, 12.5dBm, 802.11n HT20 at 19.5Mbps	Line AC	120Vac 60Hz
Standard	CFR47 Part 15 Subpart C	RBW / VBW	1MHz / 3MHz
Dist/Ant Used	3m - EMCO3115 / 1m - RA42-K-F-4B-C	Performed by	Jeremy Luong

Above 1GHz Plots for Transmit Mode at 2412MHz

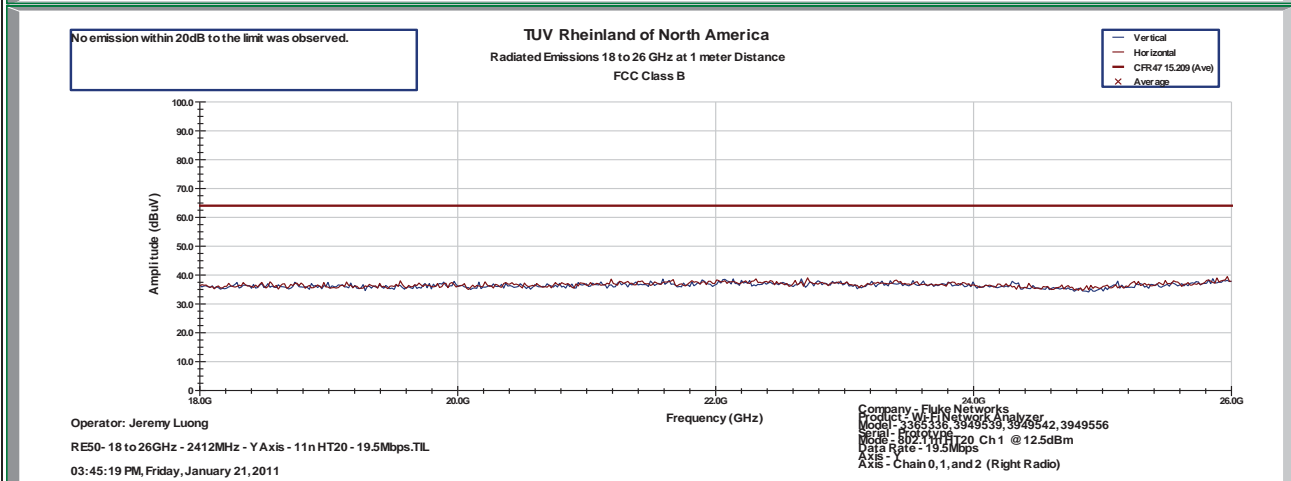
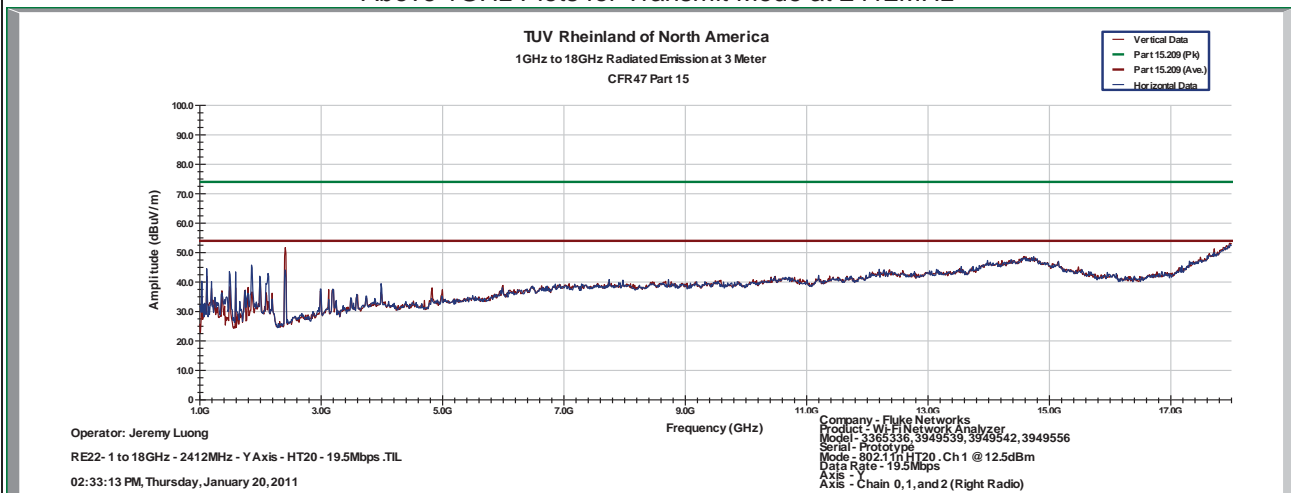

Notes: Limit was extrapolated to 1m distance for 18GHz – 25 GHz range.
 1GHz – 25 GHz Setting: RBW = 1MHz/ VBW = 3MHz

SOP 1 Radiated Emissions

Tracking # 31053887.001 Page 19 of 32

EUT Name	OPTIVIEW XG, OPVXG, OPTIVIEW XG-10G, OPVXG-10G, OPVXGPRO, OPVXG-EXPT, OPTIVIEW XG-LAN, OPVXG-LAN, OPVXG-LAN-10G, OPTIVIEW XG WLAN, OPVXG-WLAN	Date	January 20, 2011
EUT Model	3365336, 3949539, 3949542, 3949556, 3949616, 4020634	Temp / Hum in	23°C / 40%rh
EUT Serial	Prototype	Temp / Hum out	N/A
EUT Config.	Y-Axis, 12.5dBm, 802.11n HT20 at 19.5Mbps	Line AC	120Vac 60Hz
Standard	CFR47 Part 15 Subpart C	RBW / VBW	1MHz / 3MHz
Dist/Ant Used	3m - EMCO3115 / 1m - RA42-K-F-4B-C	Performed by	Jeremy Luong

Above 1GHz Plots for Transmit Mode at 2437MHz

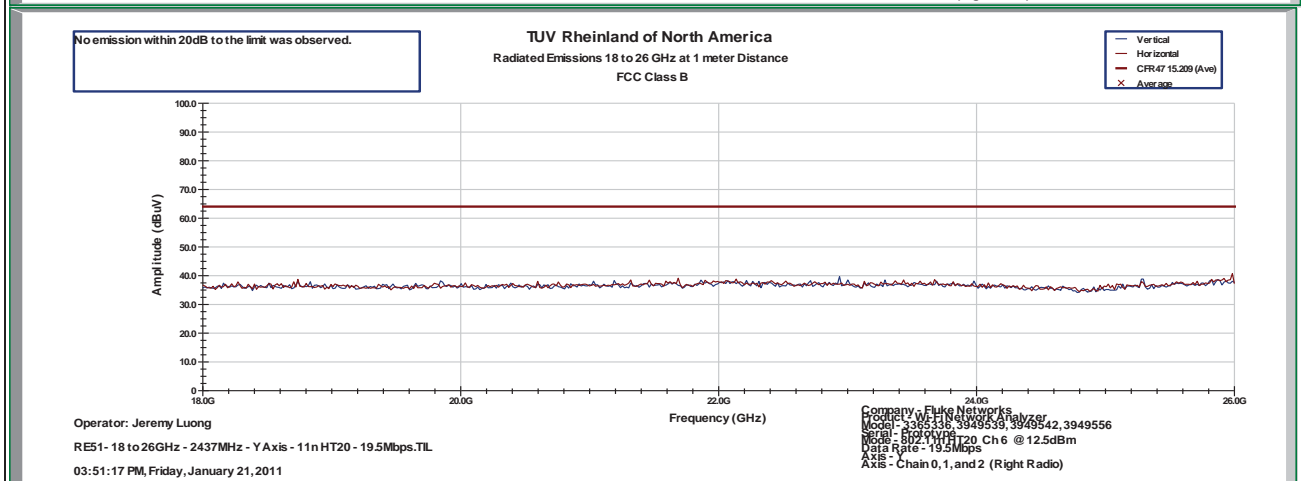
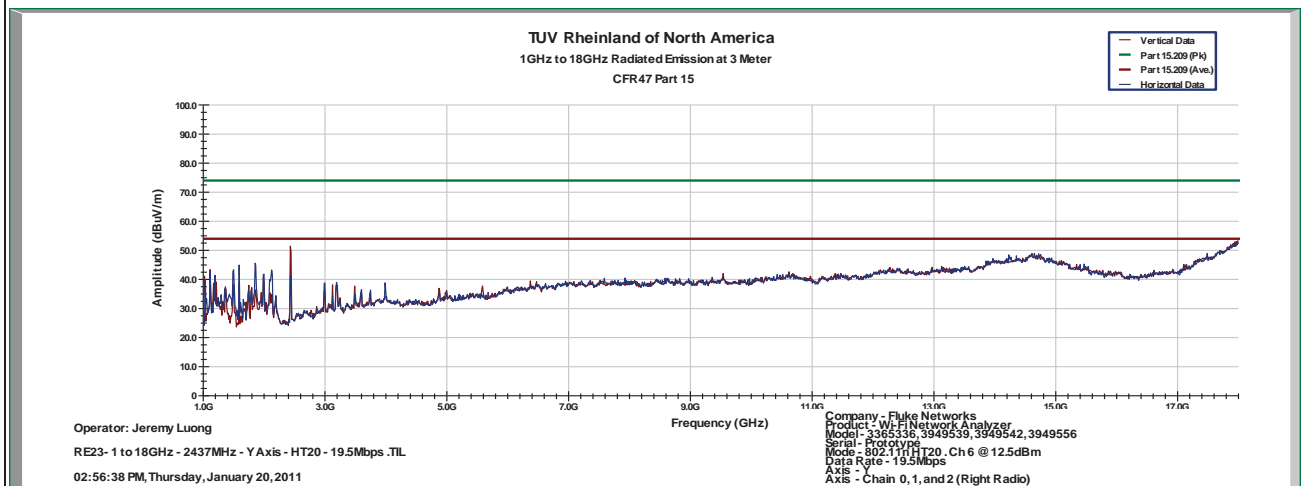

Notes: Limit was extrapolated to 1m distance for 18GHz – 25 GHz range.
 1GHz – 25 GHz Setting: RBW = 1MHz/ VBW = 3MHz

SOP 1 Radiated Emissions

Tracking # 31053887.001 Page 20 of 32

EUT Name	OPTIVIEW XG, OPVXG, OPTIVIEW XG-10G, OPVXG-10G, OPVXGPRO, OPVXG-EXPT, OPTIVIEW XG-LAN, OPVXG-LAN, OPVXG-LAN-10G, OPTIVIEW XG WLAN, OPVXG-WLAN	Date	January 20, 2011
EUT Model	3365336, 3949539, 3949542, 3949556, 3949616, 4020634	Temp / Hum in	23°C / 40%rh
EUT Serial	Prototype	Temp / Hum out	N/A
EUT Config.	Y-Axis, 12.5dBm, 802.11n HT20 at 19.5Mbps	Line AC	120Vac 60Hz
Standard	CFR47 Part 15 Subpart C	RBW / VBW	1MHz / 3MHz
Dist/Ant Used	3m - EMCO3115 / 1m - RA42-K-F-4B-C	Performed by	Jeremy Luong

Above 1GHz Plots for Transmit Mode at 2462MHz

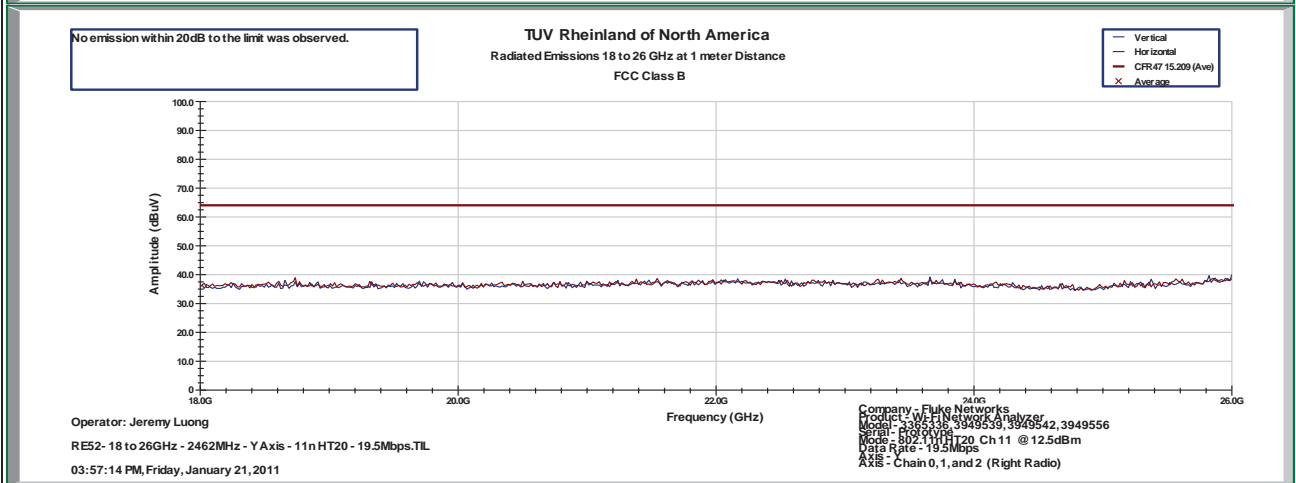
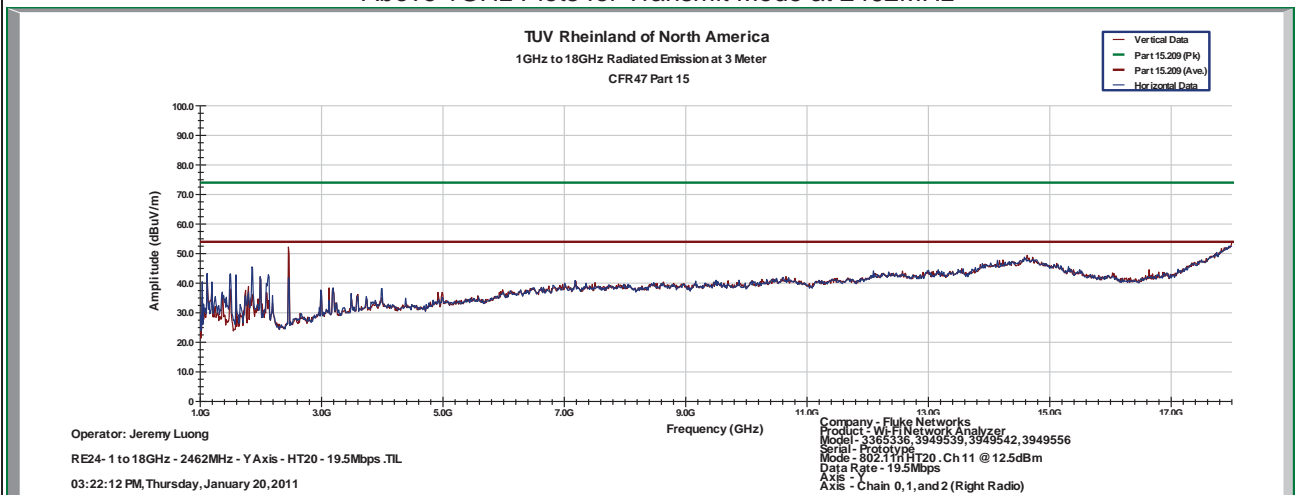

Notes: Limit was extrapolated to 1m distance for 18GHz – 25 GHz range.
 1GHz – 25 GHz Setting: RBW = 1MHz/ VBW = 3MHz

SOP 1 Radiated Emissions				Tracking # 31053887.001 Page 21 of 32							
EUT Name	OPTIVIEW XG, OPVXG, OPTIVIEW XG-10G, OPVXG-10G, OPVXGPRO, OPVXG-EXPT, OPTIVIEW XG-LAN, OPVXG-LAN, OPVXG-LAN-10G, OPTIVIEW XG WLAN, OPVXG-WLAN						Date	January 20, 2011			
EUT Model	3365336, 3949539, 3949542, 3949556, 3949616, 4020634						Temp / Hum in	23°C / 40%rh			
EUT Serial	Prototype						Temp / Hum out	N/A			
EUT Config.	Y-Axis, 12.5dBm, 802.11n HT40 at 13.5Mbps						Line AC / Freq	120Vac/60Hz			
Standard	CFR47 Part 15 Subpart C						RBW / VBW	1 MHz/ 3 MHz			
Dist/Ant Used	3m / EMCO3115 / 1m - RA42-K-F-4B-C						Performed by	Jeremy Luong			
Emission Freq (MHz)	ANT Polar (H/V)	ANT Pos (cm)	Table Pos (deg)	FIM (Pk) (dBuV/m)	FIM Ave (dBuV/m)	Total CF (dBuV)	E-Field Ave (dBuV/m)	Spec Limit (dBuV/m)	Spec Margin (dB)	Type	
Transmitted Data at 2422MHz											
1861.15	H	196	174	55.70	41.51	-4.94	36.57	53.98	-17.41	Spurious	
4840.12	V	255	166	39.18	24.33	2.50	26.83	53.98	-27.15	Harmonic	
4841.38	H	157	236	38.95	24.24	2.51	26.75	53.98	-27.23	Harmonic	
Transmitted Data at 2437MHz											
1861.03	H	98	202	55.93	42.77	-4.94	37.83	53.98	-16.15	Spurious	
4865.04	H	111	189	38.75	24.15	2.54	26.69	53.98	-27.29	Harmonic	
4866.33	V	137	-3	39.08	24.14	2.54	26.68	53.98	-27.30	Harmonic	
Transmitted Data at 2452MHz											
1861.15	H	143	204	57.44	43.43	-4.94	38.49	53.98	-15.49	Spurious	
4908.24	H	121	128	39.76	24.84	2.52	27.36	53.98	-26.62	Harmonic	
4909.71	V	143	241	37.79	24.19	2.52	26.71	53.98	-27.27	Harmonic	
Spec Margin = E-Field QP - Limit, E-Field QP = FIM QP+ Total CF ± Uncertainty											
Total CF= Amp Gain + Cable Loss + ANT Factor											
Combined Standard Uncertainty $u_c(y) = \pm 3.2$ dB Expanded Uncertainty $U = k u_c(y)$ $k = 2$ for 95% confidence											
Notes: Worst case was observed on Y-axis, 13.5Mbps. RF power transmitted at Chains 1.											

SOP 1 Radiated Emissions

Tracking # 31053887.001 Page 22 of 32

EUT Name	OPTIVIEW XG, OPVXG, OPTIVIEW XG-10G, OPVXG-10G, OPVXGPRO, OPVXG-EXPT, OPTIVIEW XG-LAN, OPVXG-LAN, OPVXG-LAN-10G, OPTIVIEW XG WLAN, OPVXG-WLAN	Date	January 20, 2011
EUT Model	3365336, 3949539, 3949542, 3949556, 3949616, 4020634	Temp / Hum in	23°C / 40%rh
EUT Serial	Prototype	Temp / Hum out	N/A
EUT Config.	Y-Axis, 12.5dBm, 802.11n HT40 at 13.5Mbps	Line AC	120Vac 60Hz
Standard	CFR47 Part 15 Subpart C	RBW / VBW	1MHz / 3MHz
Dist/Ant Used	3m - EMCO3115 / 1m - RA42-K-F-4B-C	Performed by	Jeremy Luong

Above 1GHz Plots for Transmit Mode at 2422MHz

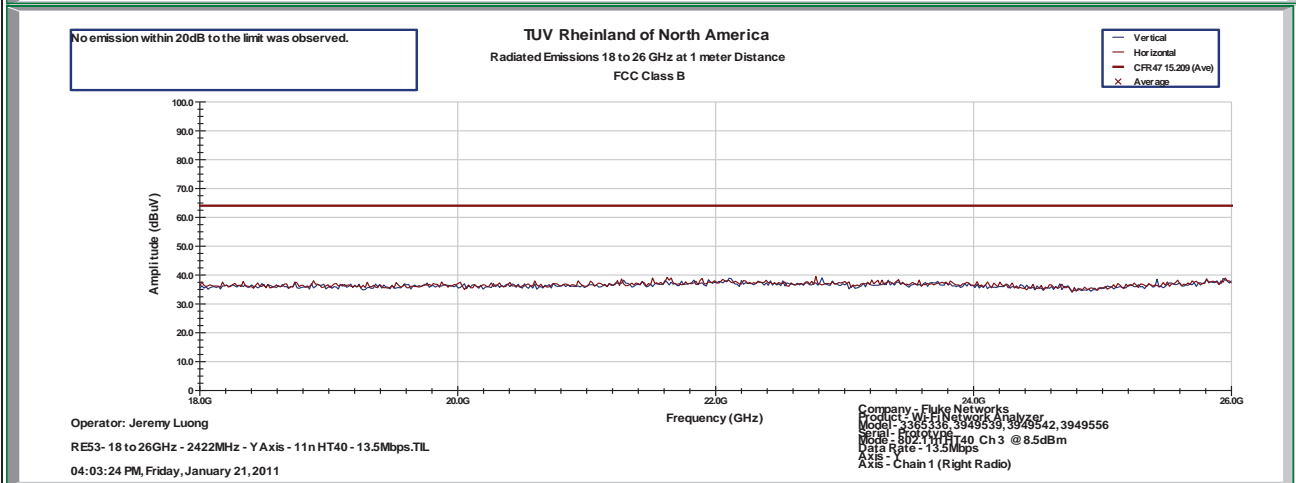
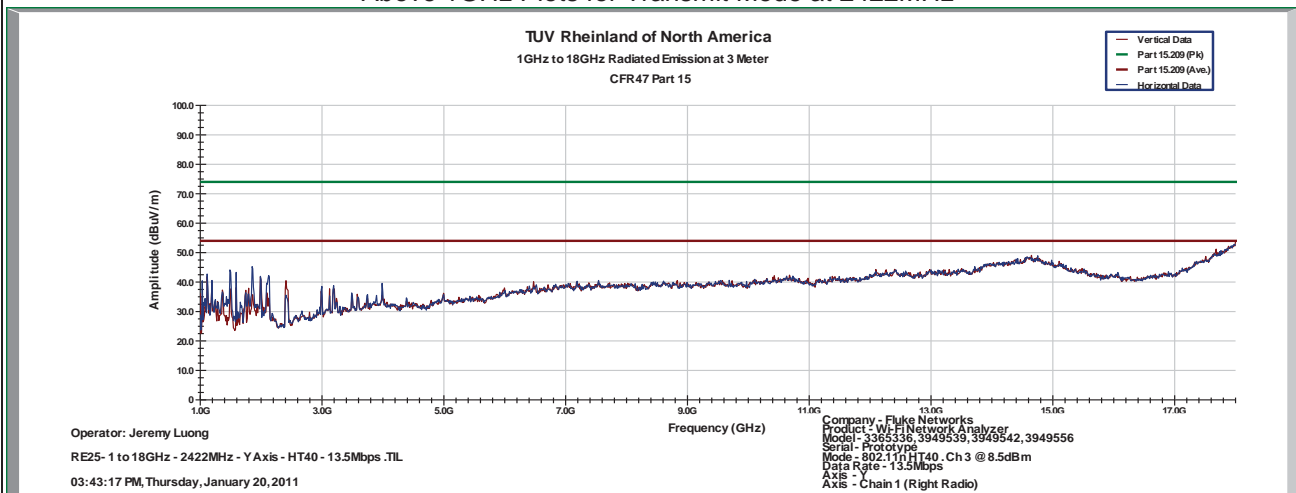

Notes: Limit was extrapolated to 1m distance for 18GHz – 25 GHz range.
 1GHz – 25 GHz Setting: RBW = 1MHz/ VBW = 3MHz

SOP 1 Radiated Emissions

Tracking # 31053887.001 Page 23 of 32

EUT Name	OPTIVIEW XG, OPVXG, OPTIVIEW XG-10G, OPVXG-10G, OPVXGPRO, OPVXG-EXPT, OPTIVIEW XG-LAN, OPVXG-LAN, OPVXG-LAN-10G, OPTIVIEW XG WLAN, OPVXG-WLAN	Date	January 20, 2011
EUT Model	3365336, 3949539, 3949542, 3949556, 3949616, 4020634	Temp / Hum in	23°C / 40%rh
EUT Serial	Prototype	Temp / Hum out	N/A
EUT Config.	Y-Axis, 12.5dBm, 802.11n HT40 at 13.5Mbps	Line AC	120Vac 60Hz
Standard	CFR47 Part 15 Subpart C	RBW / VBW	1MHz / 3MHz
Dist/Ant Used	3m - EMCO3115 / 1m - RA42-K-F-4B-C	Performed by	Jeremy Luong

Above 1GHz Plots for Transmit Mode at 2437MHz

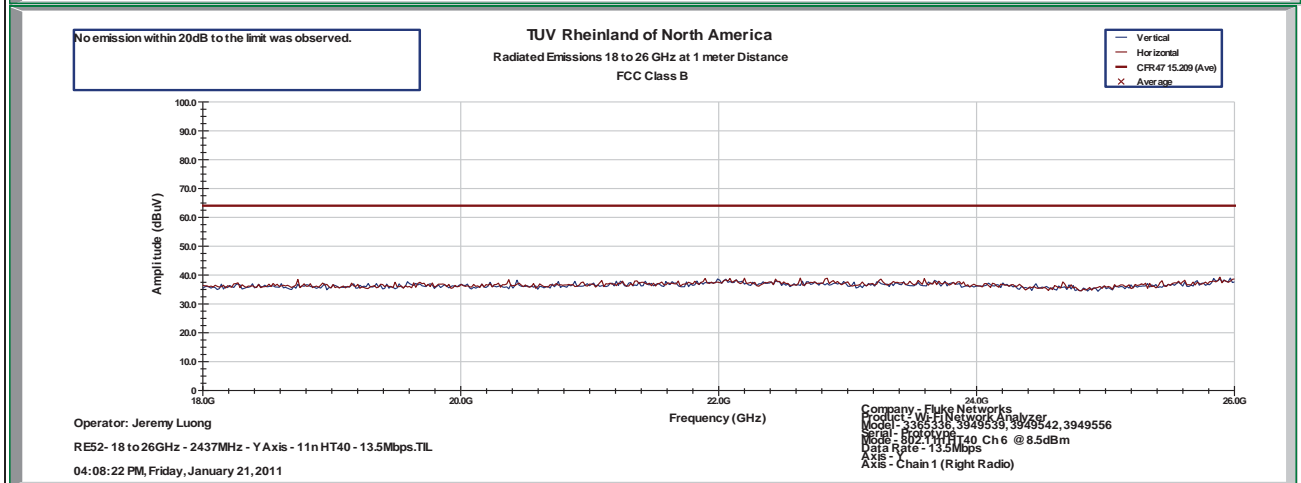
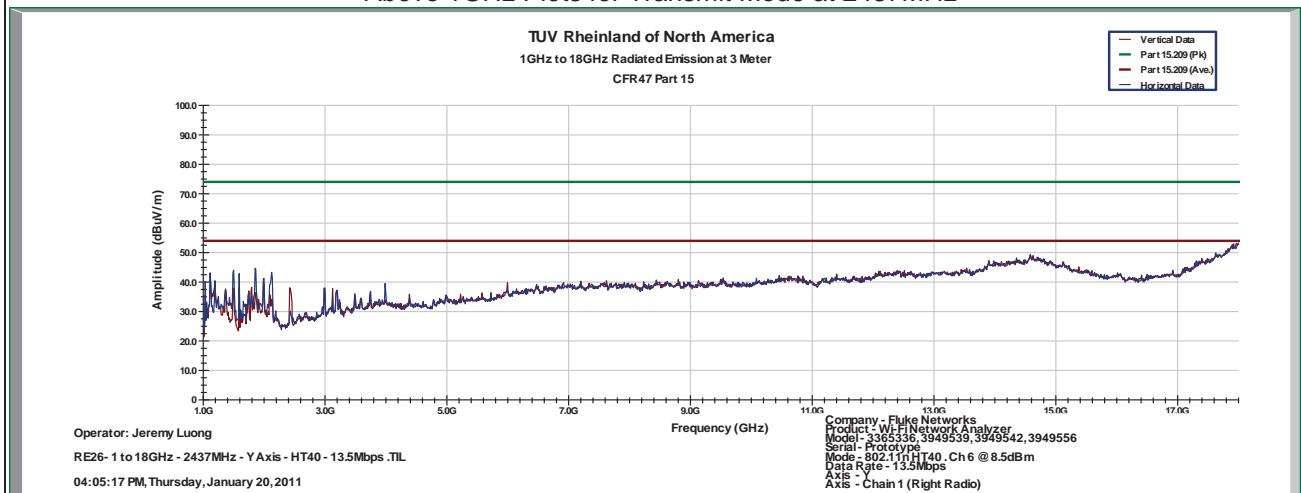

Notes: Limit was extrapolated to 1m distance for 18GHz – 25 GHz range.
 1GHz – 25 GHz Setting: RBW = 1MHz/ VBW = 3MHz

SOP 1 Radiated Emissions

Tracking # 31053887.001 Page 24 of 32

EUT Name	OPTIVIEW XG, OPVXG, OPTIVIEW XG-10G, OPVXG-10G, OPVXGPRO, OPVXG-EXPT, OPTIVIEW XG-LAN, OPVXG-LAN, OPVXG-LAN-10G, OPTIVIEW XG WLAN, OPVXG-WLAN	Date	January 20, 2011
EUT Model	3365336, 3949539, 3949542, 3949556, 3949616, 4020634	Temp / Hum in	23°C / 40%rh
EUT Serial	Prototype	Temp / Hum out	N/A
EUT Config.	Y-Axis, 12.5dBm, 802.11n HT40 at 13.5Mbps	Line AC	120Vac 60Hz
Standard	CFR47 Part 15 Subpart C	RBW / VBW	1MHz / 3MHz
Dist/Ant Used	3m - EMCO3115 / 1m - RA42-K-F-4B-C	Performed by	Jeremy Luong

Above 1GHz Plots for Transmit Mode at 2452MHz

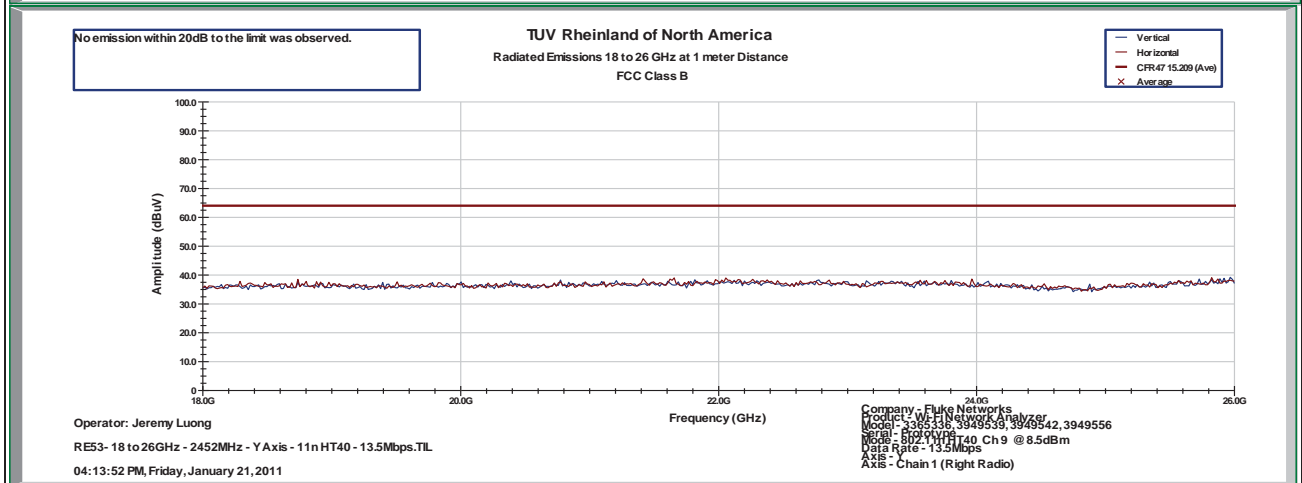
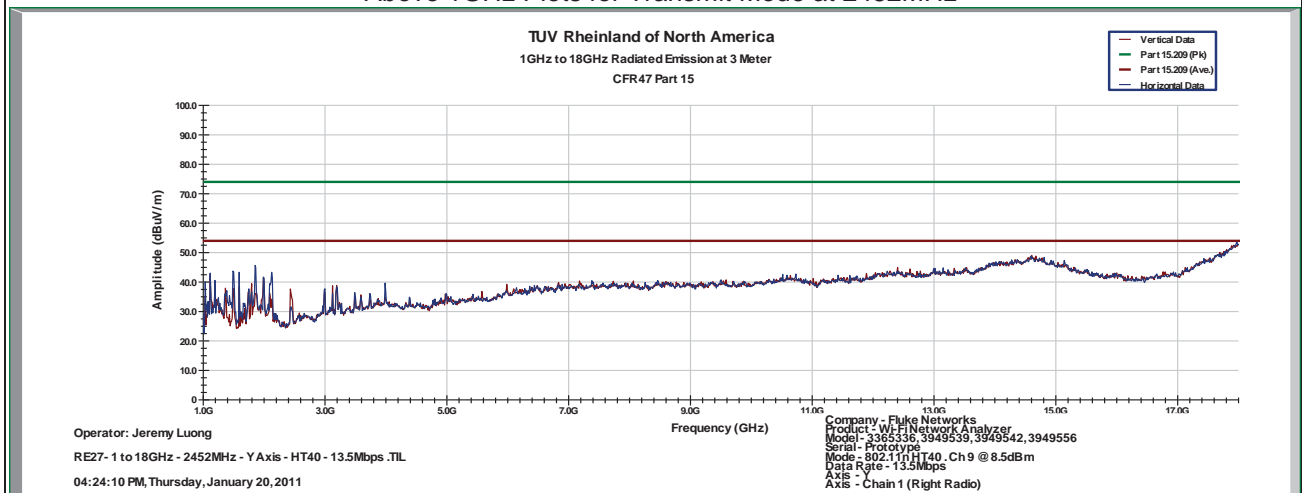

Notes: Limit was extrapolated to 1m distance for 18GHz – 25 GHz range.
 1GHz – 25 GHz Setting: RBW = 1MHz/ VBW = 3MHz

SOP 1 Radiated Emissions											Tracking # 31053887.001 Page 25 of 32	
EUT Name		OPTIVIEW XG, OPVXG, OPTIVIEW XG-10G, OPVXG-10G, OPVXGPRO, OPVXG-EXPT, OPTIVIEW XG-LAN, OPVXG-LAN, OPVXG-LAN-10G, OPTIVIEW XG WLAN, OPVXG-WLAN						Date		January 20, 2011		
EUT Model		3365336, 3949539, 3949542, 3949556, 3949616, 4020634						Temp / Hum in		23°C / 40%rh		
EUT Serial		Prototype						Temp / Hum out		N/A		
EUT Config.		Y-Axis, 12.5dBm, 802.11n HT40 at 27Mbps						Line AC / Freq		120Vac/60Hz		
Standard		CFR47 Part 15 Subpart C						RBW / VBW		1 MHz/ 3 MHz		
Dist/Ant Used		3m / EMCO3115 / 1m - RA42-K-F-4B-C						Performed by		Jeremy Luong		
Emission Freq (MHz)	ANT Polar (H/V)	ANT Pos (cm)	Table Pos (deg)	FIM (Pk) (dBuV/m)	FIM Ave (dBuV/m)	Total CF (dBuV)	E-Field Ave (dBuV/m)	Spec Limit (dBuV/m)	Spec Margin (dB)	Type		
Transmitted Data at 2422MHz												
1861.15	H	99	174	54.46	42.10	-4.94	37.16	53.98	-16.82	Spurious		
4840.21	V	176	194	39.14	24.59	2.50	27.09	53.98	-26.89	Harmonic		
4841.17	H	139	164	39.66	25.28	2.51	27.79	53.98	-26.19	Harmonic		
Transmitted Data at 2437MHz												
1861.15	H	200	173	55.38	42.92	-4.94	37.98	53.98	-16.00	Spurious		
4885.39	V	151	10	39.76	24.50	2.50	27.01	53.98	-26.97	Harmonic		
4886.05	H	190	234	40.13	25.21	2.50	27.71	53.98	-26.27	Harmonic		
Transmitted Data at 2452MHz												
1861.27	H	199	172	55.76	42.82	-4.94	37.88	53.98	-16.10	Spurious		
4890.08	H	201	179	37.95	24.18	2.49	26.67	53.98	-27.31	Harmonic		
4910.13	V	136	265	38.64	24.63	2.53	27.15	53.98	-26.83	Harmonic		
Spec Margin = E-Field QP - Limit, E-Field QP = FIM QP+ Total CF ± Uncertainty												
Total CF= Amp Gain + Cable Loss + ANT Factor												
Combined Standard Uncertainty $u_c(y) = \pm 3.2$ dB Expanded Uncertainty $U = k u_c(y)$ $k = 2$ for 95% confidence												
Notes: Worst case was observed on Y-axis, 27Mbps. RF power transmitted at Chains 0 and 1.												

SOP 1 Radiated Emissions

Tracking # 31053887.001 Page 26 of 32

EUT Name	OPTIVIEW XG, OPVXG, OPTIVIEW XG-10G, OPVXG-10G, OPVXGPRO, OPVXG-EXPT, OPTIVIEW XG-LAN, OPVXG-LAN, OPVXG-LAN-10G, OPTIVIEW XG WLAN, OPVXG-WLAN	Date	January 20, 2011
EUT Model	3365336, 3949539, 3949542, 3949556, 3949616, 4020634	Temp / Hum in	23°C / 40%rh
EUT Serial	Prototype	Temp / Hum out	N/A
EUT Config.	Y-Axis, 12.5dBm, 802.11n HT40 at 27Mbps	Line AC	120Vac 60Hz
Standard	CFR47 Part 15 Subpart C	RBW / VBW	1MHz / 3MHz
Dist/Ant Used	3m - EMCO3115 / 1m - RA42-K-F-4B-C	Performed by	Jeremy Luong

Above 1GHz Plots for Transmit Mode at 2422MHz

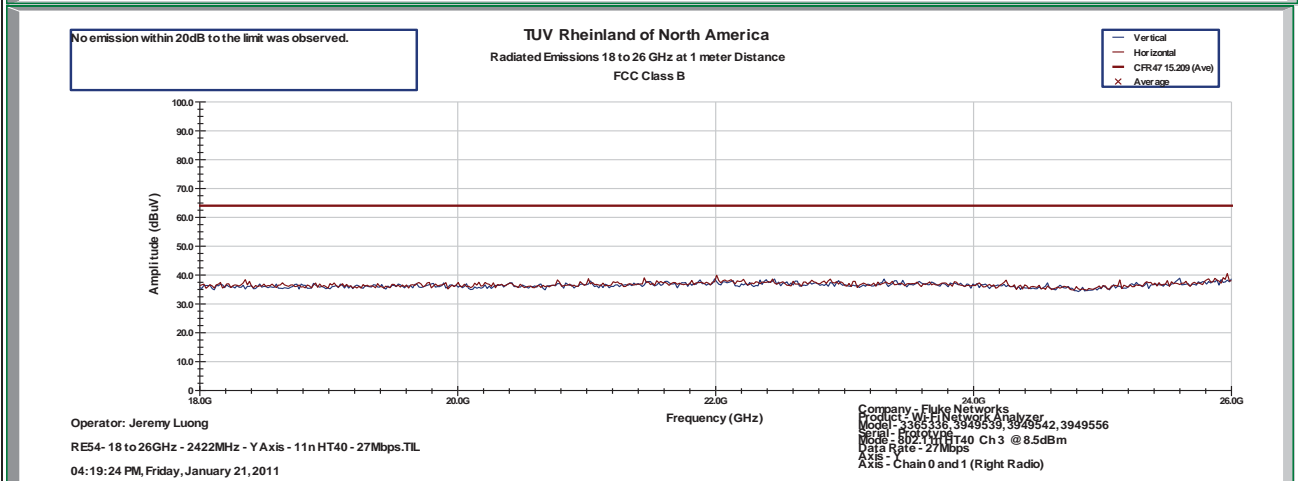
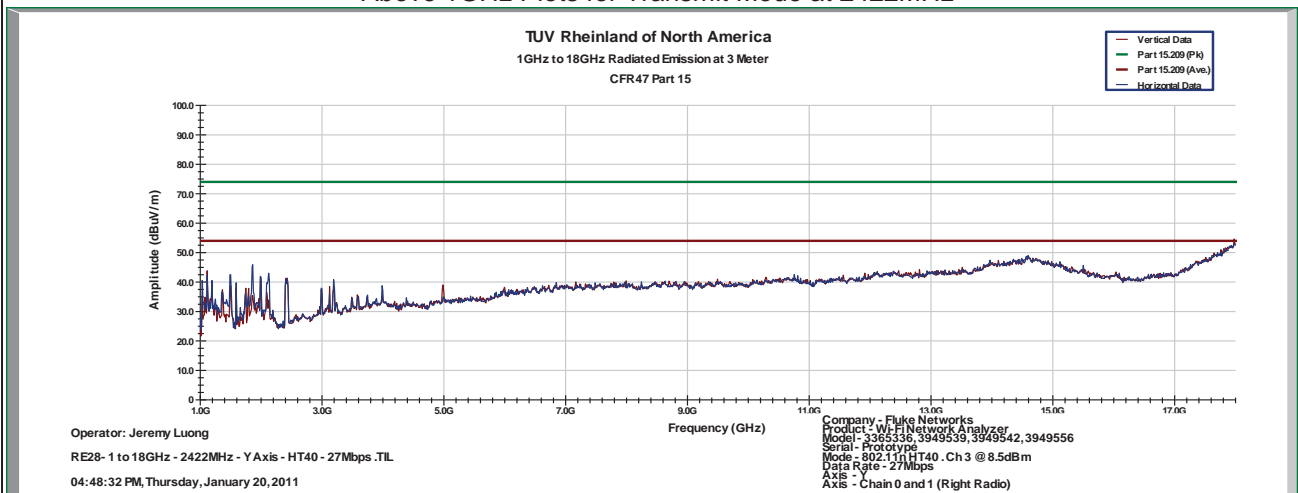

Notes: Limit was extrapolated to 1m distance for 18GHz – 25 GHz range.
 1GHz – 25 GHz Setting: RBW = 1MHz/ VBW = 3MHz

SOP 1 Radiated Emissions

Tracking # 31053887.001 Page 27 of 32

EUT Name	OPTIVIEW XG, OPVXG, OPTIVIEW XG-10G, OPVXG-10G, OPVXGPRO, OPVXG-EXPT, OPTIVIEW XG-LAN, OPVXG-LAN, OPVXG-LAN-10G, OPTIVIEW XG WLAN, OPVXG-WLAN	Date	January 21, 2011
EUT Model	3365336, 3949539, 3949542, 3949556, 3949616, 4020634	Temp / Hum in	23°C / 40%rh
EUT Serial	Prototype	Temp / Hum out	N/A
EUT Config.	Y-Axis, 12.5dBm, 802.11n HT40 at 27Mbps	Line AC	120Vac 60Hz
Standard	CFR47 Part 15 Subpart C	RBW / VBW	1MHz / 3MHz
Dist/Ant Used	3m - EMCO3115 / 1m - RA42-K-F-4B-C	Performed by	Jeremy Luong

Above 1GHz Plots for Transmit Mode at 2437MHz

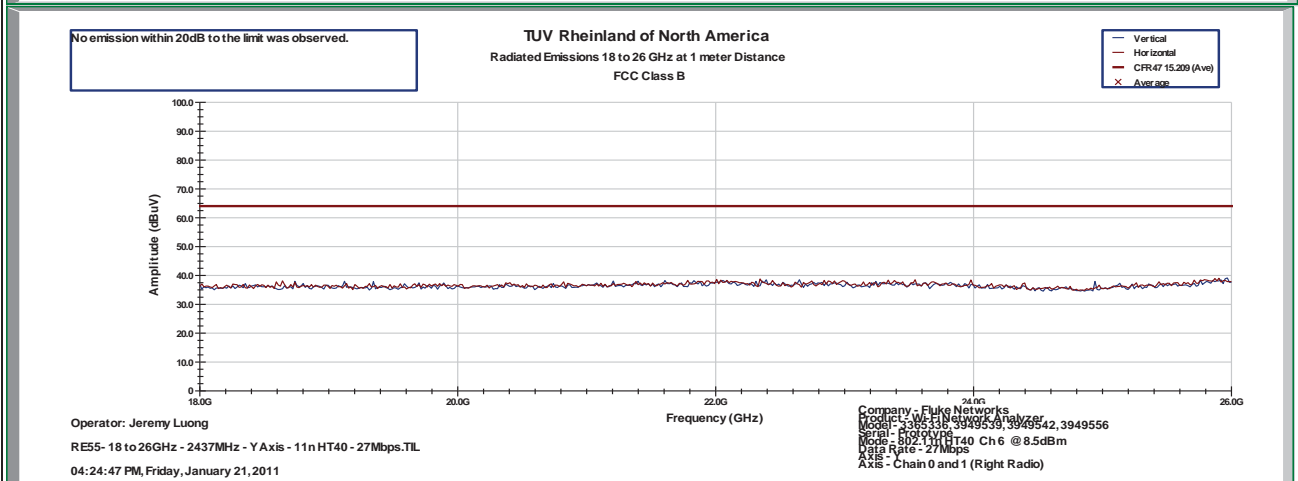
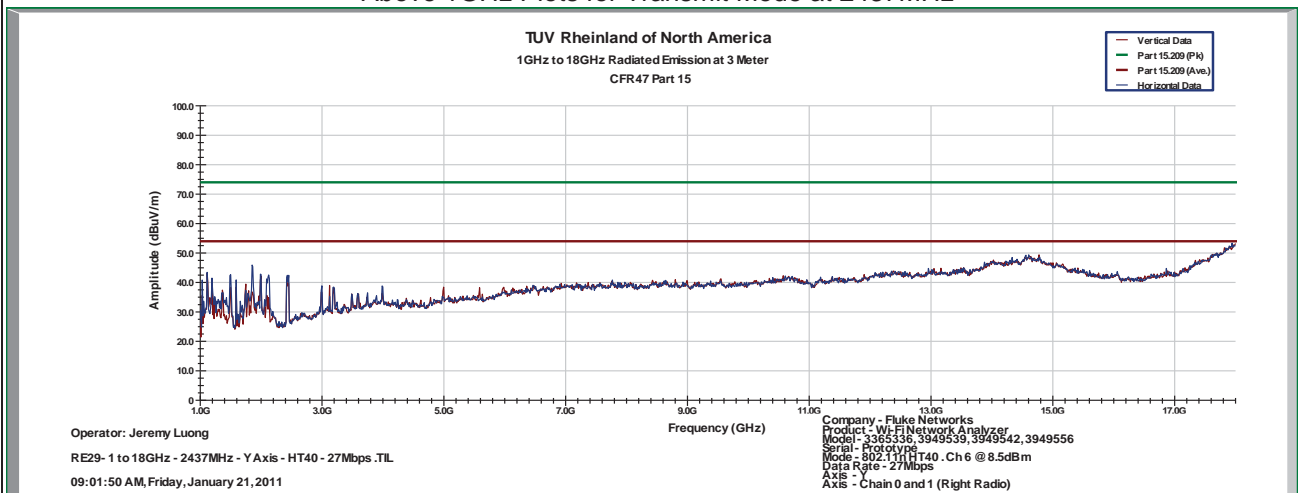

Notes: Limit was extrapolated to 1m distance for 18GHz – 25 GHz range.
 1GHz – 25 GHz Setting: RBW = 1MHz/ VBW = 3MHz

SOP 1 Radiated Emissions

Tracking # 31053887.001 Page 28 of 32

EUT Name	OPTIVIEW XG, OPVXG, OPTIVIEW XG-10G, OPVXG-10G, OPVXGPRO, OPVXG-EXPT, OPTIVIEW XG-LAN, OPVXG-LAN, OPVXG-LAN-10G, OPTIVIEW XG WLAN, OPVXG-WLAN	Date	January 21, 2011
EUT Model	3365336, 3949539, 3949542, 3949556, 3949616, 4020634	Temp / Hum in	23°C / 40%rh
EUT Serial	Prototype	Temp / Hum out	N/A
EUT Config.	Y-Axis, 12.5dBm, 802.11n HT40 at 27Mbps	Line AC	120Vac 60Hz
Standard	CFR47 Part 15 Subpart C	RBW / VBW	1MHz / 3MHz
Dist/Ant Used	3m - EMCO3115 / 1m - RA42-K-F-4B-C	Performed by	Jeremy Luong

Above 1GHz Plots for Transmit Mode at 2452MHz

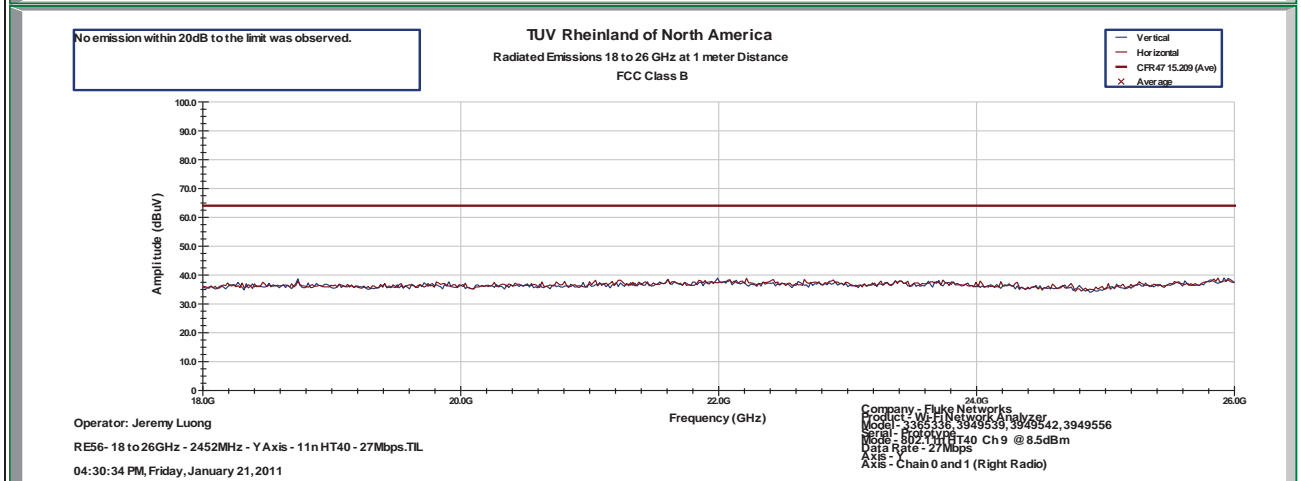
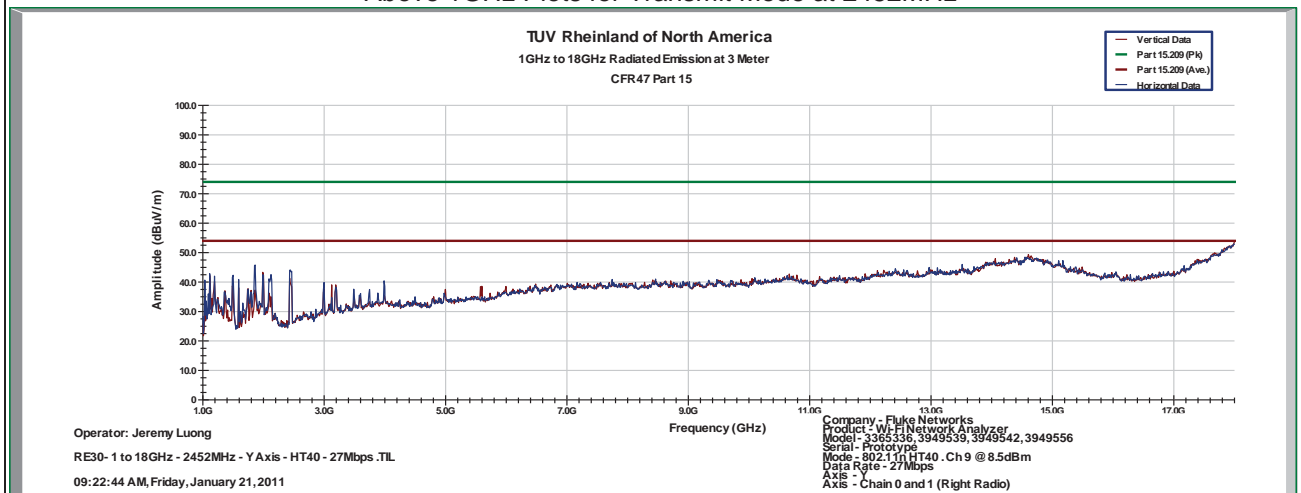

Notes: Limit was extrapolated to 1m distance for 18GHz – 25 GHz range.
 1GHz – 25 GHz Setting: RBW = 1MHz/ VBW = 3MHz

SOP 1 Radiated Emissions											Tracking # 31053887.001 Page 29 of 32	
EUT Name		OPTIVIEW XG, OPVXG, OPTIVIEW XG-10G, OPVXG-10G, OPVXGPRO, OPVXG-EXPT, OPTIVIEW XG-LAN, OPVXG-LAN, OPVXG-LAN-10G, OPTIVIEW XG WLAN, OPVXG-WLAN						Date		January 21, 2011		
EUT Model		3365336, 3949539, 3949542, 3949556, 3949616, 4020634						Temp / Hum in		23°C / 40%rh		
EUT Serial		Prototype						Temp / Hum out		N/A		
EUT Config.		Y-Axis, 12.5dBm, 802.11n HT40 at 40.5Mbps						Line AC / Freq		120Vac/60Hz		
Standard		CFR47 Part 15 Subpart C						RBW / VBW		1 MHz/ 3 MHz		
Dist/Ant Used		3m / EMCO3115 / 1m - RA42-K-F-4B-C						Performed by		Jeremy Luong		
Emission Freq (MHz)	ANT Polar (H/V)	ANT Pos (cm)	Table Pos (deg)	FIM (Pk) (dBuV/m)	FIM Ave (dBuV/m)	Total CF (dBuV)	E-Field Ave (dBuV/m)	Spec Limit (dBuV/m)	Spec Margin (dB)	Type		
Transmitted Data at 2422MHz												
1861.09	H	100	194	56.24	43.45	-4.94	38.51	53.98	-15.47	Spurious		
4843.07	V	206	179	40.35	25.93	2.52	28.45	53.98	-25.53	Harmonic		
4884.79	H	138	160	40.14	25.60	2.50	28.10	53.98	-25.88	Harmonic		
Transmitted Data at 2437MHz												
1861.09	H	143	198	56.88	43.73	-4.94	38.79	53.98	-15.19	Spurious		
4862.88	V	156	367	39.79	25.01	2.54	27.55	53.98	-26.43	Harmonic		
4874.03	H	161	110	38.09	24.57	2.52	27.09	53.98	-26.89	Harmonic		
Transmitted Data at 2452MHz												
1861.15	H	145	177	56.68	42.62	-4.94	37.68	53.98	-16.30	Spurious		
4895.94	H	173	372	37.29	24.21	2.48	26.69	53.98	-27.29	Harmonic		
4909.08	V	121	129	38.00	25.21	2.52	27.73	53.98	-26.25	Harmonic		
Spec Margin = E-Field QP - Limit, E-Field QP = FIM QP+ Total CF ± Uncertainty												
Total CF= Amp Gain + Cable Loss + ANT Factor												
Combined Standard Uncertainty $u_c(y) = \pm 3.2$ dB Expanded Uncertainty $U = k u_c(y)$ $k = 2$ for 95% confidence												
Notes: Worst case was observed on Y-axis, 40.5Mbps. RF power transmitted at Chains 0, 1, and 2.												

SOP 1 Radiated Emissions

Tracking # 31053887.001 Page 30 of 32

EUT Name	OPTIVIEW XG, OPVXG, OPTIVIEW XG-10G, OPVXG-10G, OPVXGPRO, OPVXG-EXPT, OPTIVIEW XG-LAN, OPVXG-LAN, OPVXG-LAN-10G, OPTIVIEW XG WLAN, OPVXG-WLAN	Date	January 21, 2011
EUT Model	3365336, 3949539, 3949542, 3949556, 3949616, 4020634	Temp / Hum in	23°C / 40%rh
EUT Serial	Prototype	Temp / Hum out	N/A
EUT Config.	Y-Axis, 12.5dBm, 802.11n HT40 at 40.5Mbps	Line AC	120Vac 60Hz
Standard	CFR47 Part 15 Subpart C	RBW / VBW	1MHz / 3MHz
Dist/Ant Used	3m - EMCO3115 / 1m - RA42-K-F-4B-C	Performed by	Jeremy Luong

Above 1GHz Plots for Transmit Mode at 2422MHz

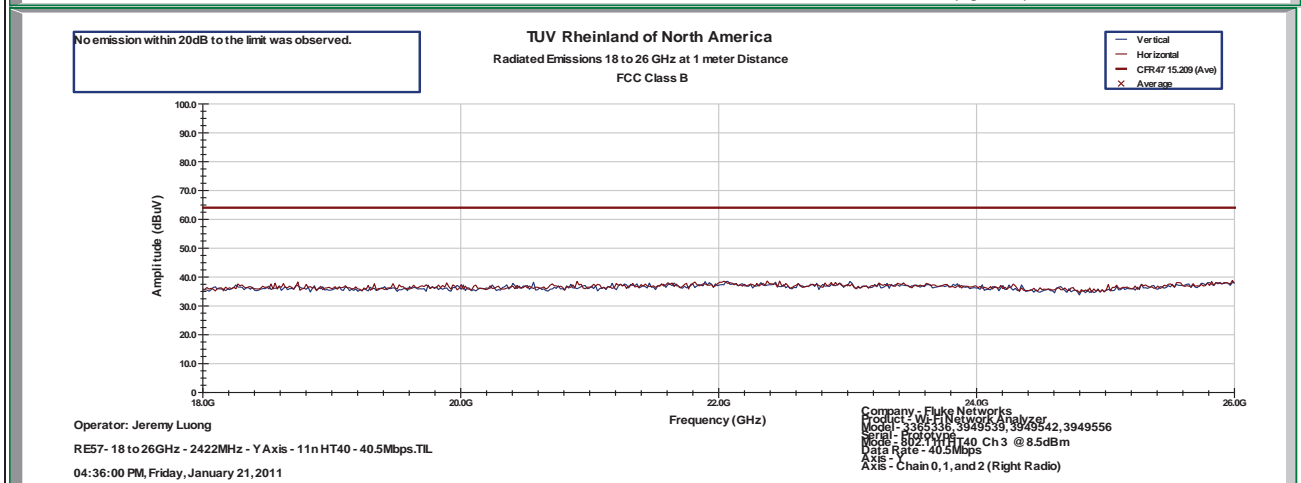
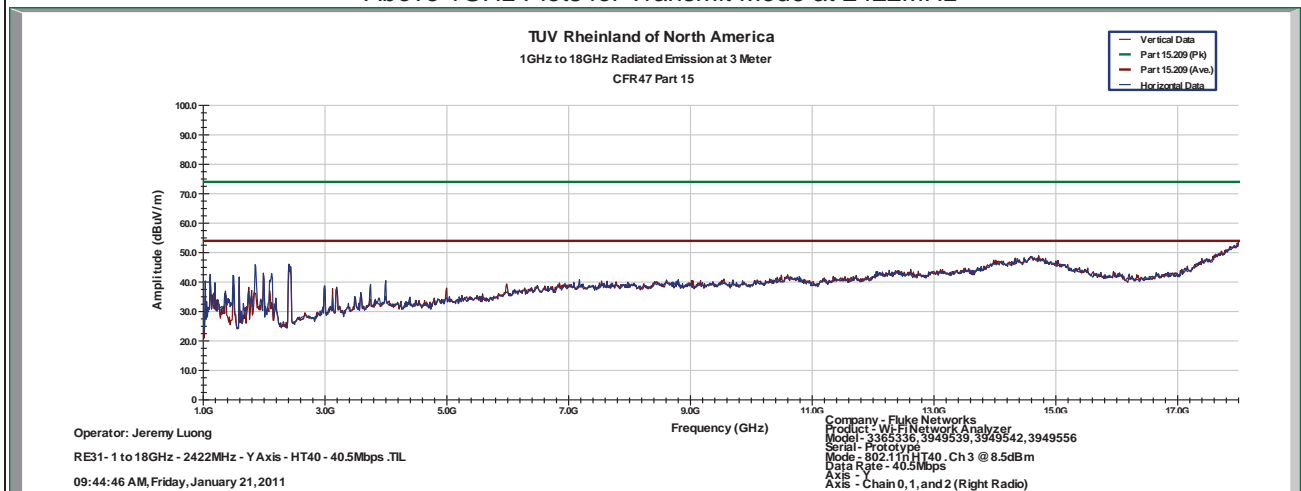

Notes: Limit was extrapolated to 1m distance for 18GHz – 25 GHz range.
 1GHz – 25 GHz Setting: RBW = 1MHz/ VBW = 3MHz

SOP 1 Radiated Emissions

Tracking # 31053887.001 Page 31 of 32

EUT Name	OPTIVIEW XG, OPVXG, OPTIVIEW XG-10G, OPVXG-10G, OPVXGPRO, OPVXG-EXPT, OPTIVIEW XG-LAN, OPVXG-LAN, OPVXG-LAN-10G, OPTIVIEW XG WLAN, OPVXG-WLAN	Date	January 21, 2011
EUT Model	3365336, 3949539, 3949542, 3949556, 3949616, 4020634	Temp / Hum in	23°C / 40%rh
EUT Serial	Prototype	Temp / Hum out	N/A
EUT Config.	Y-Axis, 12.5dBm, 802.11n HT40 at 40.5Mbps	Line AC	120Vac 60Hz
Standard	CFR47 Part 15 Subpart C	RBW / VBW	1MHz / 3MHz
Dist/Ant Used	3m - EMCO3115 / 1m - RA42-K-F-4B-C	Performed by	Jeremy Luong

Above 1GHz Plots for Transmit Mode at 2437MHz

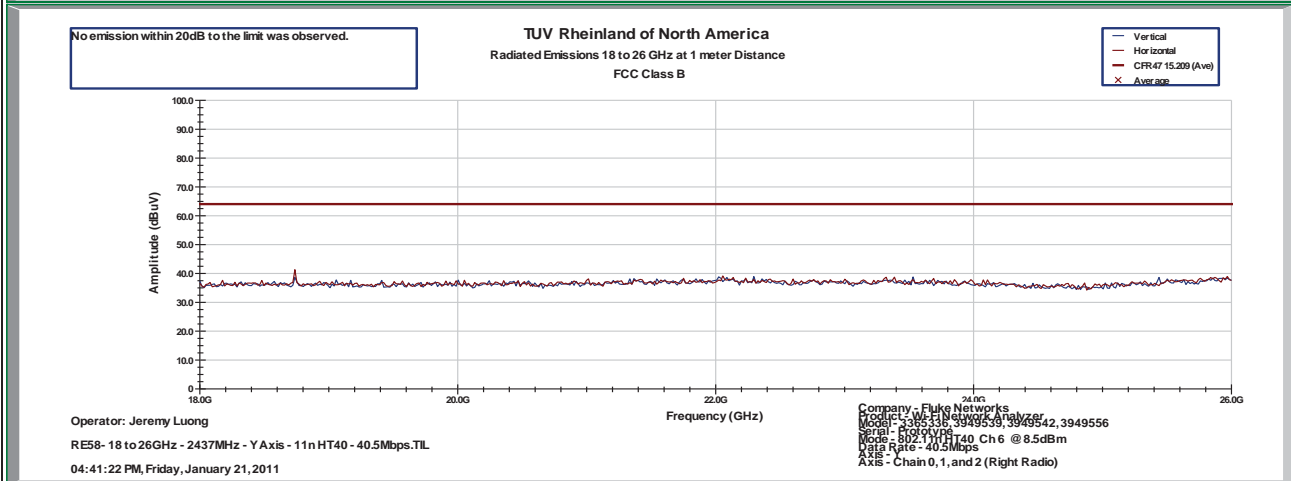
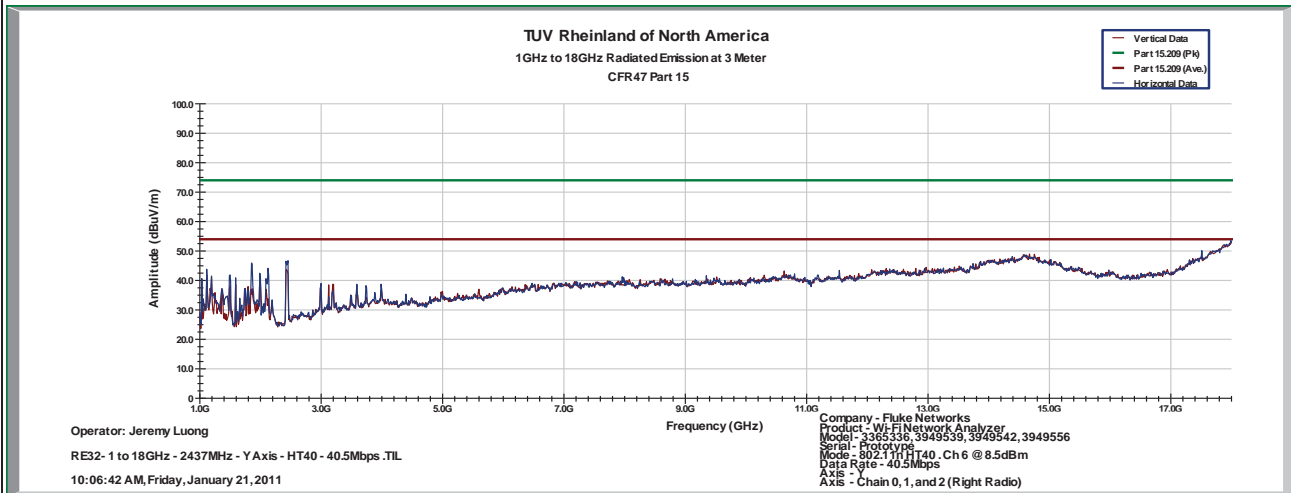

Notes: Limit was extrapolated to 1m distance for 18GHz – 25 GHz range.
 1GHz – 25 GHz Setting: RBW = 1MHz/ VBW = 3MHz

SOP 1 Radiated Emissions

Tracking # 31053887.001 Page 32 of 32

EUT Name	OPTIVIEW XG, OPVXG, OPTIVIEW XG-10G, OPVXG-10G, OPVXGPRO, OPVXG-EXPT, OPTIVIEW XG-LAN, OPVXG-LAN, OPVXG-LAN-10G, OPTIVIEW XG WLAN, OPVXG-WLAN	Date	January 21, 2011
EUT Model	3365336, 3949539, 3949542, 3949556, 3949616, 4020634	Temp / Hum in	23°C / 40%rh
EUT Serial	Prototype	Temp / Hum out	N/A
EUT Config.	Y-Axis, 12.5dBm, 802.11n HT40 at 40.5Mbps	Line AC	120Vac 60Hz
Standard	CFR47 Part 15 Subpart C	RBW / VBW	1MHz / 3MHz
Dist/Ant Used	3m - EMCO3115 / 1m - RA42-K-F-4B-C	Performed by	Jeremy Luong

Above 1GHz Plots for Transmit Mode at 2452MHz

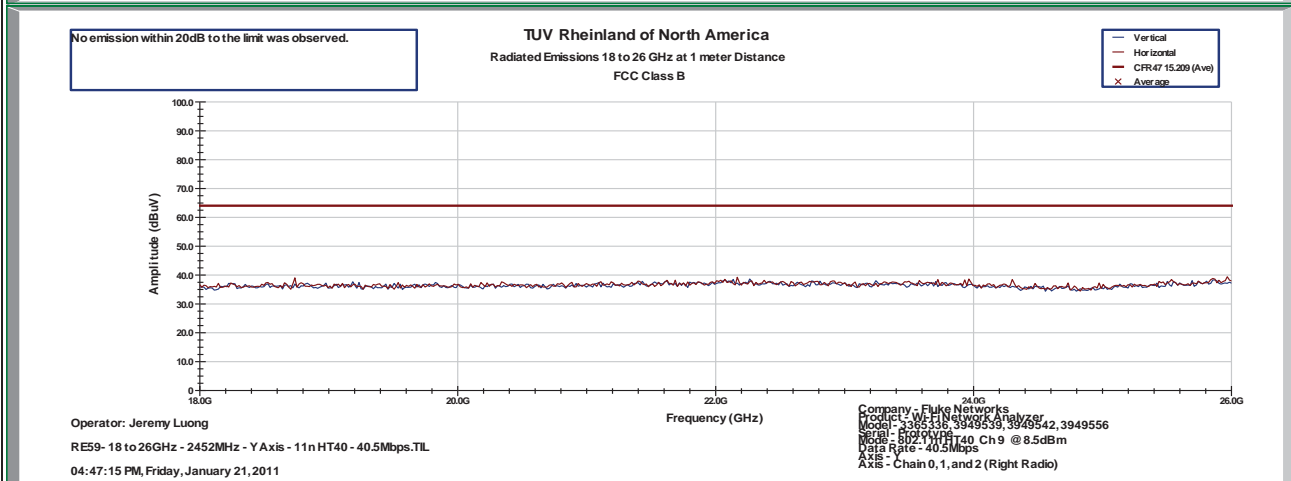
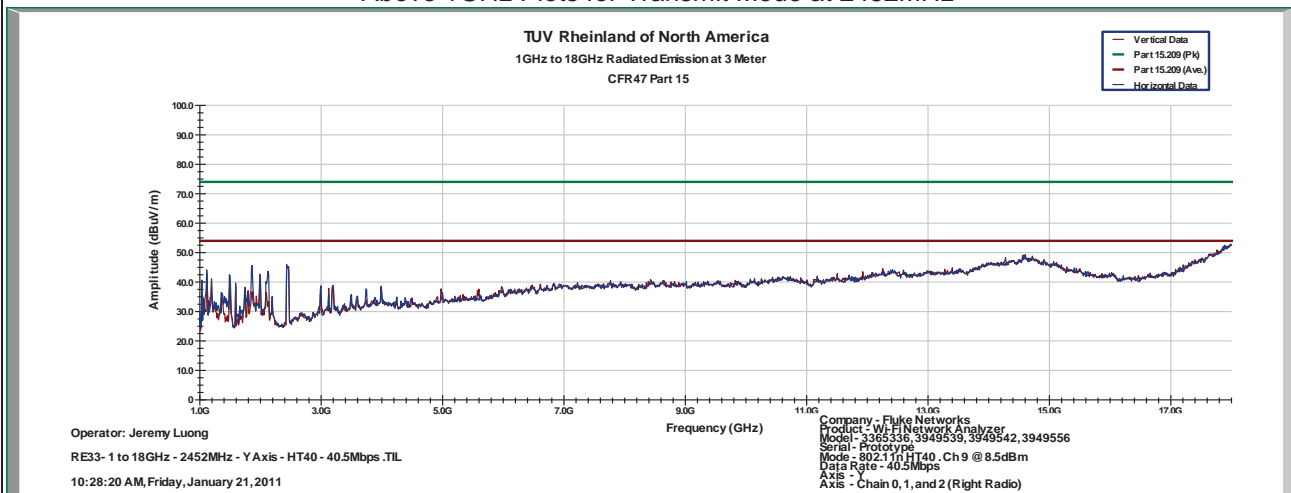

Notes: Limit was extrapolated to 1m distance for 18GHz – 25 GHz range.
 1GHz – 25 GHz Setting: RBW = 1MHz/ VBW = 3MHz

4.5.4 Sample Calculation

The field strength is calculated by subtracting the Amplifier Gain and adding the Cable Loss and Antenna Correction Factor to the measured reading. The basic equation is as follows:

$$\text{Field Strength (dB}\mu\text{V/m)} = \text{FIM} - \text{AMP} + \text{CBL} + \text{ACF}$$

Where: FIM = Field Intensity Meter (dB μ V)
AMP = Amplifier Gain (dB)
CBL = Cable Loss (dB)
ACF = Antenna Correction Factor (dB/m)

$$\mu\text{V/m} = 10^{\frac{\text{dB}\mu\text{V/m}}{20}}$$

4.6 Receiver Spurious Emissions

Receiver spurious emissions are emissions at any frequency when the equipment is in receive mode.

The spurious emissions of the receiver shall not exceed the values in CFR47 Part 15.109 and RSS GEN Sect 6.1.

4.6.1 Test Methodology

4.6.1.1 Preliminary Test

A test program that controls instrumentation and data logging was used to automate the preliminary RF emission test procedure. The frequency range of interest was divided into sub-ranges to yield a frequency resolution of approximately 120 kHz and provide a reading at each frequency for no more than 12° of turntable rotation. For each frequency sub-range the turntable was rotated 360° while peak emission data was recorded and plotted over the frequency range of interest in horizontal and vertical antenna polarization's.

Preliminary emission profile testing was performed inside the anechoic chamber. The EUT was placed on a 1.0m x 1.5m non-conductive table 80cm above the floor. The EUT was positioned as shown in the setup photographs. The receiving antenna was placed at a distance of 3m at a fixed height of 1m. Measurement equipment was located outside of the chamber. A video camera was placed inside the chamber to view the EUT.

4.6.1.2 Final Test

For each frequency measured, the peak emission was maximized by manipulating the receiving antenna from 1 to 4 meters above the ground plane and placing it at the position that produced the maximum signal strength reading. The turntable was then rotated through 360° while observing the peak signal and placing the EUT at the position that produced maximum radiation. The six highest emissions relative to the limit were measured unless such emissions were more than 20 dB below the limit. If less than six emissions are within 20 dB of the limit, than the noise level of the receiver is measured at frequencies where emissions are expected. Multiples of all oscillator and microprocessor frequencies were also checked.

Final testing was performed on an NSA compliant test site. The EUT was placed on a 1.0m x 1.5m non-conductive table 80cm above the ground plane. The placement of EUT and cables were the same as for preliminary testing and is shown in the setup photographs.

4.6.1.3 Deviations

None.

4.6.2 Receiver Spurious Emission Limit

The spurious emissions of the receiver shall not exceed the values in CFR47 Part 15.109: 2009 and RSS GEN Sect 6.1 2010.

Frequency (MHz)	Field strength (microvolts/meter)	Measurement distance (meters)
0.009-0.490.....	2400/F(kHz)	300
0.490-1.705.....	24000/F(kHz)	30
1.705-30.0.....	30	30
30-88.....	100 **	3
88-216.....	150 **	3
216-960.....	200 **	3
Above 960.....	500	3

4.6.3 Test Results

The final measurement data indicates the worst case operating modes, configurations, and/or cable positions. It also reflects the results including any modifications and/or special accessories listed in Sections 1.4 and 1.5.

As originally tested, the EUT was found to be compliant to the requirements of the test standard(s).

4.6.3.1 Final Data

The data recorded in this section contains the final results under the worst-case conditions and without any modifications or special accessories implemented as the manufacturer intends.

SOP 1 Radiated Emissions				Tracking # 31053887.001 Page 1 of 12						
EUT Name	OPTIVIEW XG, OPVXG, OPTIVIEW XG-10G, OPVXG-10G, OPVXGPRO, OPVXG-EXPT, OPTIVIEW XG-LAN, OPVXG-LAN, OPVXG-LAN-10G, OPTIVIEW XG WLAN, OPVXG-WLAN					Date	January 21, 2011			
EUT Model	3365336, 3949539, 3949542, 3949556, 3949616, 4020634					Temp / Hum in	22°C / 40%rh			
EUT Serial	Prototype					Temp / Hum out	N/A			
EUT Config.	Y-Axis, 802.11b, RX at Ch6, 1Mbps					Line AC / Freq	120Vac 60Hz			
Standard	CFR47 Part 15.109, Class A					RBW / VBW	See Note			
Dist/Ant Used	3m / JB3 & EMCO3115					Performed by	Jeremy Luong			
Emission Freq (MHz)	ANT Polar (H/V)	ANT Pos (cm)	Table Pos (deg)	FIM (Pk) (dBuV/m)	FIM QP/Ave (dBuV/m)	Total CF (dBuV)	E-Field QP/Ave (dBuV/m)	Spec Limit (dBuV/m)	Spec Margin (dB)	Type
Receive Mode										
78.17	H	261	48	61.02	58.31	-16.20	42.11	49.54	-7.43	Spurious
500.02	H	145	203	42.54	40.35	-5.26	35.09	56.90	-21.81	Spurious
719.99	H	107	340	43.43	43.06	-1.14	41.92	56.90	-14.98	Spurious
750.01	H	102	137	47.04	46.27	-0.63	45.64	56.90	-11.26	Spurious
871.49	H	141	222	49.77	48.70	0.80	49.50	56.90	-7.40	Spurious
874.31	H	142	219	50.97	49.10	0.75	49.85	56.90	-7.05	Spurious
78.32	V	108	305	56.67	54.51	-16.80	37.71	49.54	-11.83	Spurious
400.00	V	135	354	48.68	47.26	-7.15	40.11	56.90	-16.79	Spurious
750.01	V	106	105	41.43	40.41	-1.23	39.18	56.90	-17.72	Spurious
871.27	V	111	70	46.66	44.52	0.25	44.77	56.90	-12.13	Spurious
874.31	V	115	43	47.08	44.33	0.33	44.66	56.90	-12.24	Spurious
1861.12	H	155	202	57.88	44.37	-4.94	39.43	60.00	-20.57	Spurious
2127.13	H	159	197	56.02	36.03	-4.37	31.66	60.00	-28.34	Spurious
2392.91	H	163	132	54.13	33.13	-3.00	30.13	60.00	-29.87	Spurious
2490.38	H	165	262	52.97	32.27	-2.68	29.59	60.00	-30.41	Spurious
3125.05	V	155	195	48.49	36.27	-0.48	35.80	60.00	-24.20	Spurious
3197.53	V	191	217	48.04	27.29	-0.03	27.26	60.00	-32.74	Spurious
Spec Margin = E-Field QP - Limit, E-Field QP = FIM QP+ Total CF ± Uncertainty										
Total CF= Amp Gain + Cable Loss + ANT Factor										
Combined Standard Uncertainty $u_c(y) = \pm 3.2\text{dB}$ Expanded Uncertainty $U = ku_c(y)$ $k = 2$ for 95% confidence										
Notes: Tested on the Y-Axis at Ch 6. 30 MHz – 1GHz: RBW=120 kHz, VBW=300 kHz 1GHz – 25 GHz: RBW=1MHz, VBW=3MHz										

SOP 1 Radiated Emissions

Tracking # 31053887.00 Page 2 of 12
 1

EUT Name	OPTIVIEW XG, OPVXG, OPTIVIEW XG-10G, OPVXG-10G, OPVXGPRO, OPVXG-EXPT, OPTIVIEW XG-LAN, OPVXG-LAN, OPVXG-LAN-10G, OPTIVIEW XG WLAN, OPVXG-WLAN	Date	January 21, 2011
EUT Model	3365336, 3949539, 3949542, 3949556, 3949616, 4020634	Temp / Hum in	22°C / 40%rh
EUT Serial	Prototype	Temp / Hum out	N/A
EUT Config.	Y-Axis, 802.11b, RX at Ch6, 1Mbps	Line AC	120Vac 60Hz
Standard	CFR47 Part 15.109, Class A	RBW / VBW	120 kHz / 300 kHz
Dist/Ant Used	3m / JB3	Performed by	Jeremy Luong

30 MHz to 1000 MHz Plots for Receive Mode

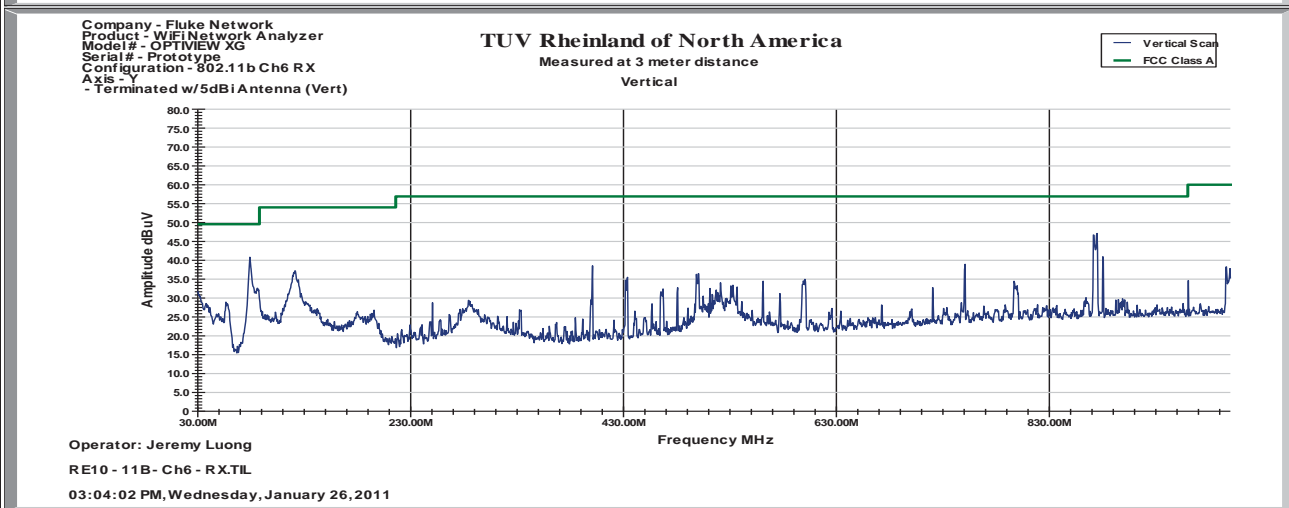
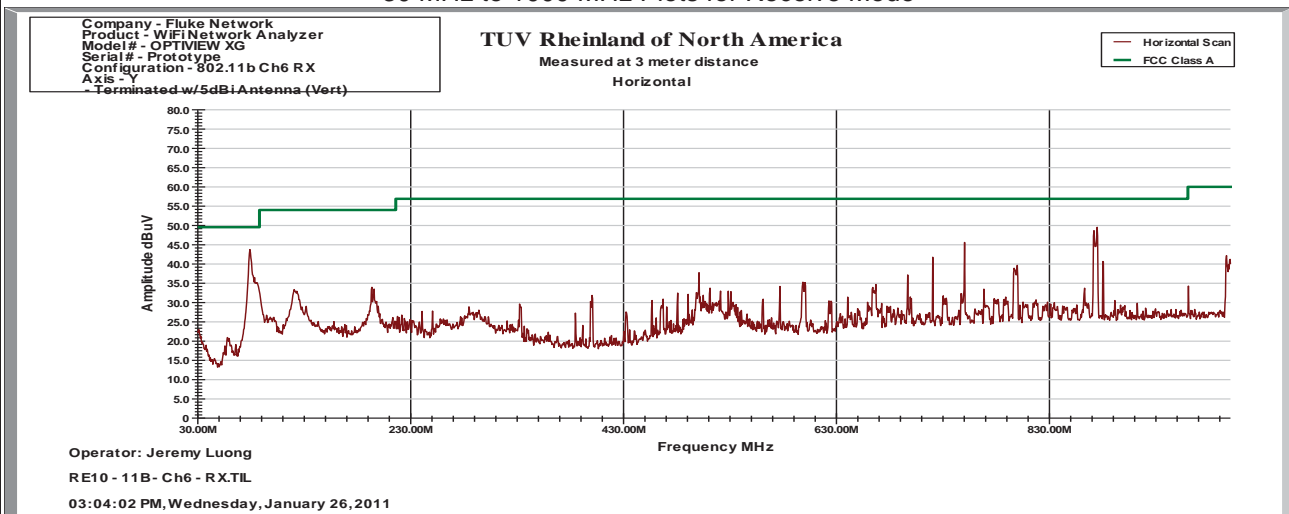

Notes: None.

SOP 1 Radiated Emissions

Tracking # 31053887.001 Page 3 of 12

EUT Name	OPTIVIEW XG, OPVXG, OPTIVIEW XG-10G, OPVXG-10G, OPVXGPRO, OPVXG-EXPT, OPTIVIEW XG-LAN, OPVXG-LAN, OPVXG-LAN-10G, OPTIVIEW XG WLAN, OPVXG-WLAN	Date	January 21, 2011
EUT Model	3365336, 3949539, 3949542, 3949556, 3949616, 4020634	Temp / Hum in	23°C / 40%rh
EUT Serial	Prototype	Temp / Hum out	N/A
EUT Config.	Y-Axis, 802.11b, RX at Ch6, 1Mbps	Line AC	120Vac 60Hz
Standard	CFR47 Part 15.109, Class A	RBW / VBW	1MHz / 3MHz
Dist/Ant Used	3m / EMCO3115	Performed by	Jeremy Luong

Above 1GHz Plot for Receive Mode

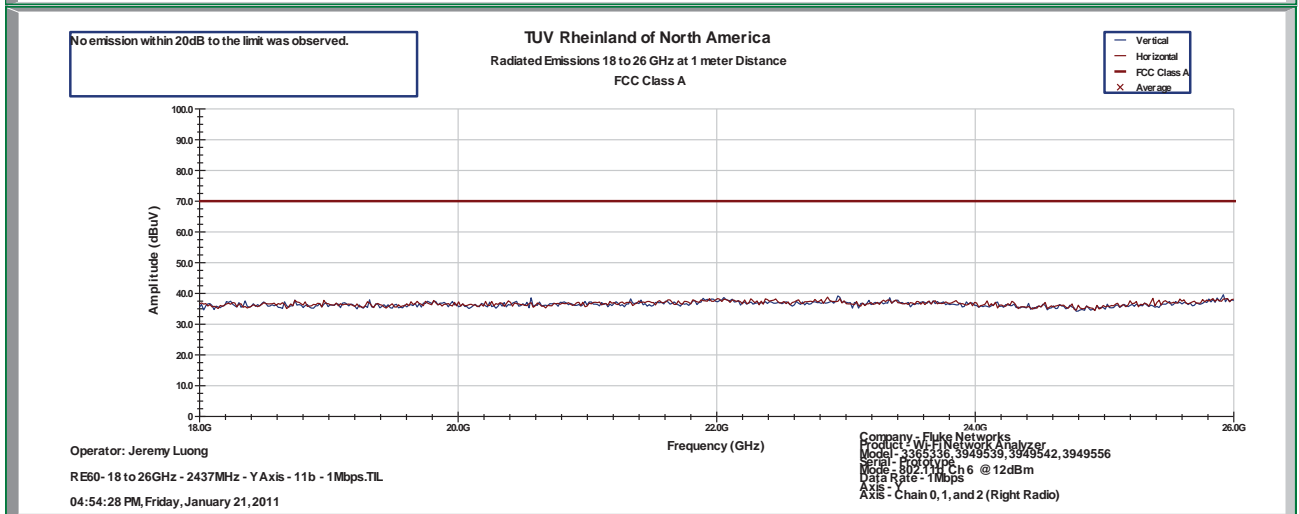
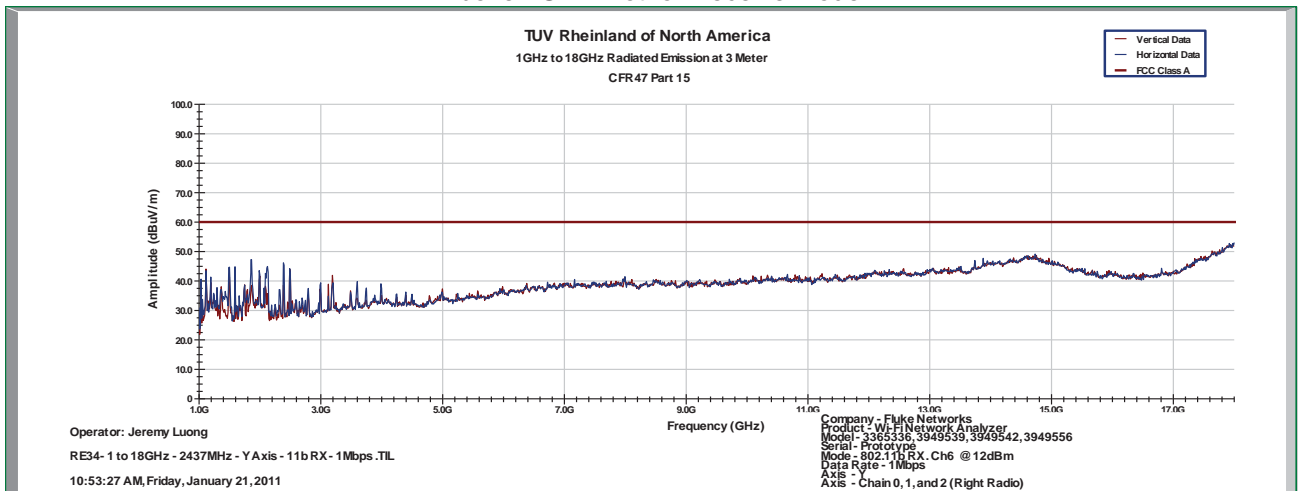

Notes: None.

SOP 1 Radiated Emissions				Tracking # 31053887.001 Page 4 of 12						
EUT Name	OPTIVIEW XG, OPVXG, OPTIVIEW XG-10G, OPVXG-10G, OPVXGPRO, OPVXG-EXPT, OPTIVIEW XG-LAN, OPVXG-LAN, OPVXG-LAN-10G, OPTIVIEW XG WLAN, OPVXG-WLAN						Date	January 24, 2011		
EUT Model	3365336, 3949539, 3949542, 3949556, 3949616, 4020634						Temp / Hum in	22°C / 40%rh		
EUT Serial	Prototype						Temp / Hum out	N/A		
EUT Config.	Y-Axis, 802.11g, RX at Ch6, 6Mbps						Line AC / Freq	120Vac 60Hz		
Standard	CFR47 Part 15.109, Class A						RBW / VBW	See Note		
Dist/Ant Used	3m / JB3 & EMCO3115						Performed by	Jeremy Luong		
Emission Freq (MHz)	ANT Polar (H/V)	ANT Pos (cm)	Table Pos (deg)	FIM (Pk) (dBuV/m)	FIM QP/Ave (dBuV/m)	Total CF (dBuV)	E-Field QP/Ave (dBuV/m)	Spec Limit (dBuV/m)	Spec Margin (dB)	Type
Receive Mode										
119.88	V	106	103	45.96	42.96	-10.00	32.96	53.98	-21.02	Spurious
400.00	V	120	6	48.32	46.94	-7.15	39.79	56.90	-17.11	Spurious
500.02	V	106	157	47.28	46.42	-5.66	40.76	56.90	-16.14	Spurious
750.06	V	119	108	40.84	40.22	-1.22	39.00	56.90	-17.90	Spurious
871.52	V	111	52	45.97	44.79	0.26	45.05	56.90	-11.85	Spurious
874.16	V	148	38	45.56	43.99	0.32	44.31	56.90	-12.59	Spurious
121.16	H	222	230	44.98	42.53	-9.75	32.78	53.98	-21.20	Spurious
500.03	H	140	124	50.74	48.26	-5.26	43.00	56.90	-13.90	Spurious
625.04	H	111	165	45.82	44.71	-3.08	41.63	56.90	-15.27	Spurious
719.99	H	102	337	42.69	42.06	-1.14	40.92	56.90	-15.98	Spurious
750.05	H	164	143	45.23	43.46	-0.62	42.84	56.90	-14.06	Spurious
871.17	H	214	278	45.66	43.93	0.80	44.73	56.90	-12.17	Spurious
874.20	H	147	241	48.66	48.03	0.75	48.78	56.90	-8.12	Spurious
1495.16	H	129	142	58.77	39.66	-7.69	31.97	60.00	-28.03	Spurious
1861.21	H	96	235	59.90	45.47	-4.94	40.53	60.00	-19.47	Spurious
2093.73	H	183	115	54.90	34.31	-4.58	29.73	60.00	-30.27	Spurious
2392.96	H	128	142	54.01	34.61	-3.00	31.61	60.00	-28.39	Spurious
2490.39	H	128	257	51.89	31.77	-2.68	29.09	60.00	-30.91	Spurious
Spec Margin = E-Field QP - Limit, E-Field QP = FIM QP+ Total CF ± Uncertainty										
Total CF= Amp Gain + Cable Loss + ANT Factor										
Combined Standard Uncertainty $u_c(y) = \pm 3.2\text{dB}$ Expanded Uncertainty $U = ku_c(y)$ $k = 2$ for 95% confidence										
Notes: Tested on the Y-Axis at Ch 6.										
30 MHz – 1GHz: RBW=120 kHz, VBW=300 kHz										
1GHz – 25 GHz: RBW=1MHz, VBW=3MHz										

SOP 1 Radiated Emissions

Tracking # 31053887.001 Page 5 of 12

EUT Name	OPTIVIEW XG, OPVXG, OPTIVIEW XG-10G, OPVXG-10G, OPVXGPRO, OPVXG-EXPT, OPTIVIEW XG-LAN, OPVXG-LAN, OPVXG-LAN-10G, OPTIVIEW XG WLAN, OPVXG-WLAN	Date	January 24, 2011
EUT Model	3365336, 3949539, 3949542, 3949556, 3949616, 4020634	Temp / Hum in	22°C / 40%rh
EUT Serial	Prototype	Temp / Hum out	N/A
EUT Config.	Y-Axis, 802.11g, RX at Ch6, 6Mbps	Line AC	120Vac 60Hz
Standard	CFR47 Part 15.109, Class A	RBW / VBW	120 kHz / 300 kHz
Dist/Ant Used	3m / JB3	Performed by	Jeremy Luong

30 MHz to 1000 MHz Plots for Receive Mode

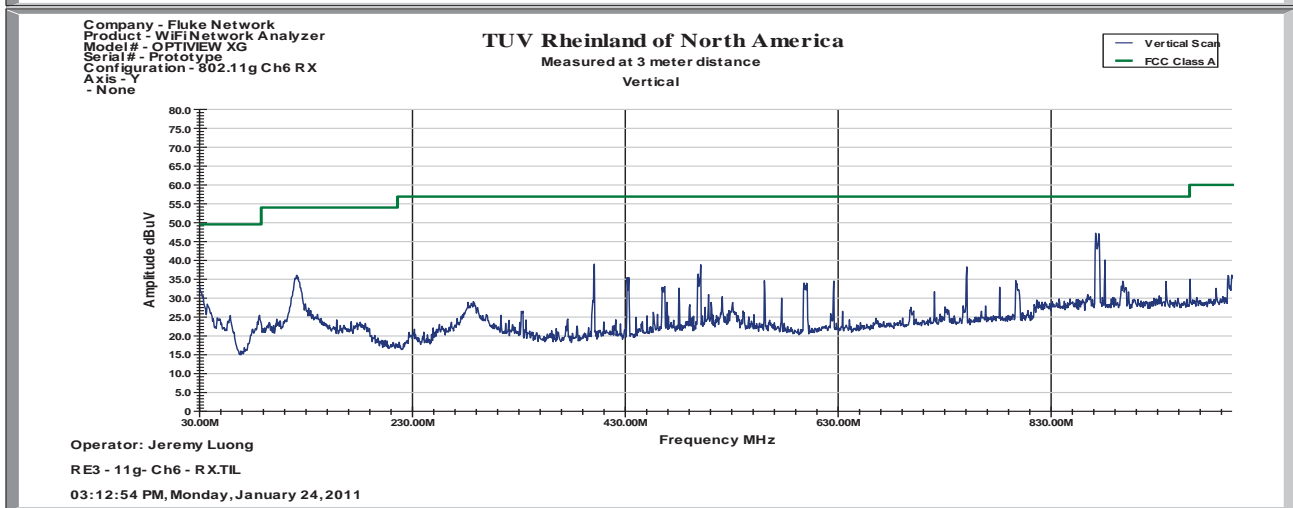
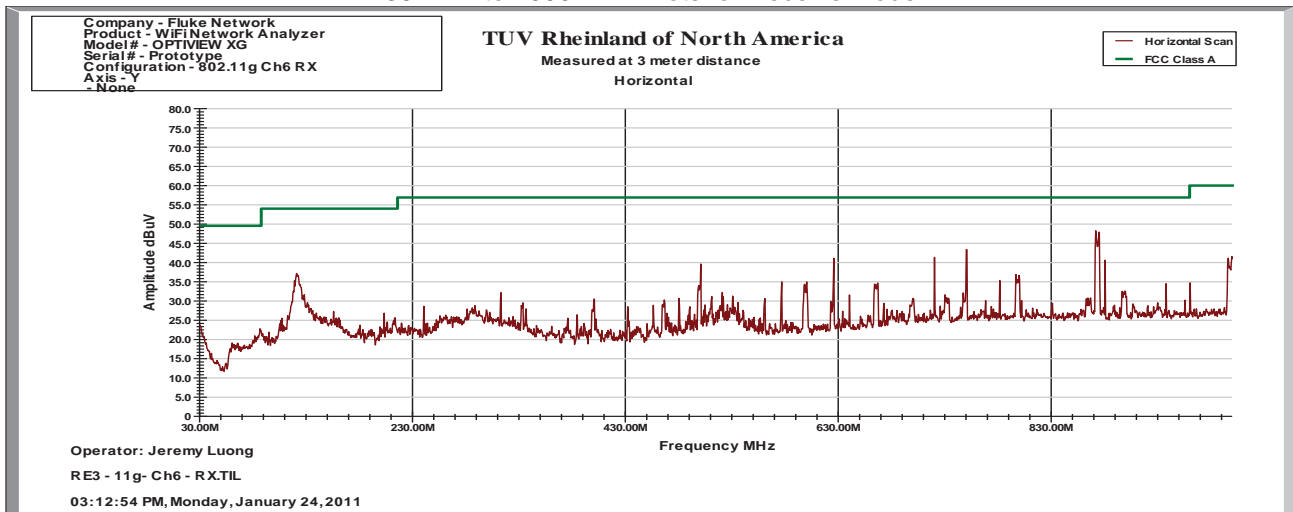

Notes: None.

SOP 1 Radiated Emissions

Tracking # 31053887.001 Page 6 of 12

EUT Name	OPTIVIEW XG, OPVXG, OPTIVIEW XG-10G, OPVXG-10G, OPVXGPRO, OPVXG-EXPT, OPTIVIEW XG-LAN, OPVXG-LAN, OPVXG-LAN-10G, OPTIVIEW XG WLAN, OPVXG-WLAN	Date	January 21, 2011
EUT Model	3365336, 3949539, 3949542, 3949556, 3949616, 4020634	Temp / Hum in	23°C / 40%rh
EUT Serial	Prototype	Temp / Hum out	N/A
EUT Config.	Y-Axis, 802.11g, RX at Ch6, 6Mbps	Line AC	120Vac 60Hz
Standard	CFR47 Part 15.109, Class A	RBW / VBW	1MHz / 3MHz
Dist/Ant Used	3m / EMCO3115	Performed by	Jeremy Luong

Above 1GHz Plot for Receive Mode

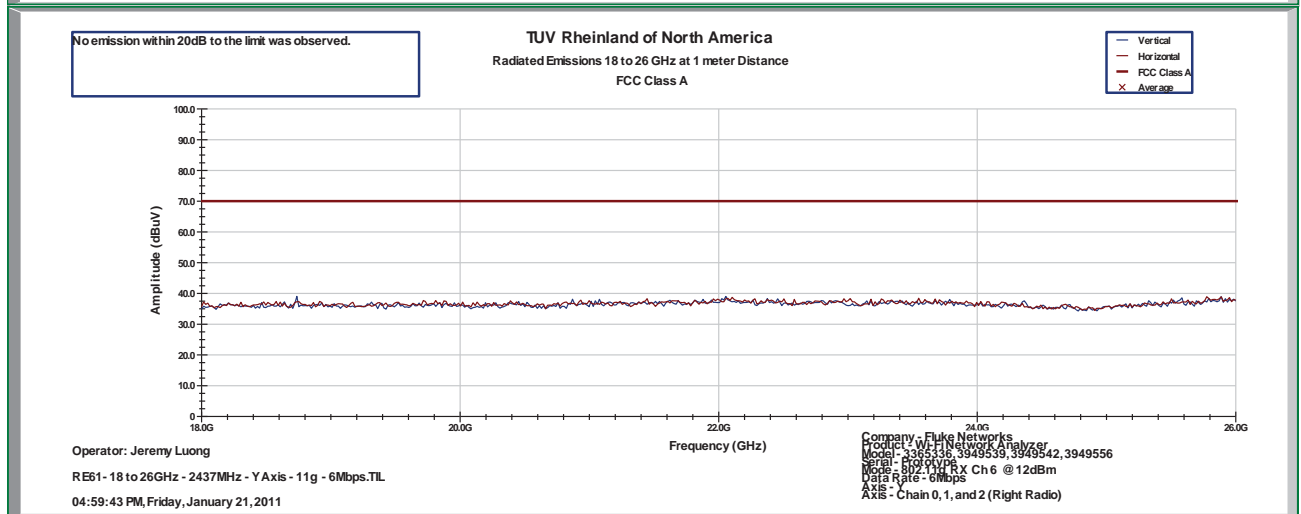
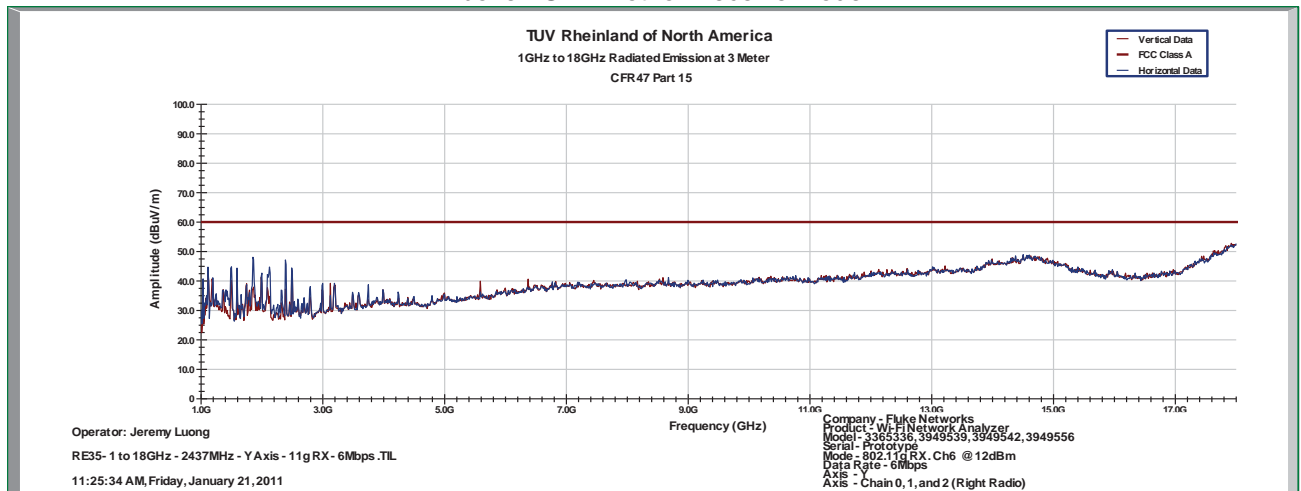

Notes: None.

SOP 1 Radiated Emissions											Tracking # 31053887.001 Page 7 of 12	
EUT Name	OPTIVIEW XG, OPVXG, OPTIVIEW XG-10G, OPVXG-10G, OPVXGPRO, OPVXG-EXPT, OPTIVIEW XG-LAN, OPVXG-LAN, OPVXG-LAN-10G, OPTIVIEW XG WLAN, OPVXG-WLAN						Date	January 24, 2011				
EUT Model	3365336, 3949539, 3949542, 3949556, 3949616, 4020634						Temp / Hum in	22°C / 40%rh				
EUT Serial	Prototype						Temp / Hum out	N/A				
EUT Config.	Y-Axis, 802.11n HT20, RX at Ch6, 19.5Mbps						Line AC / Freq	120Vac 60Hz				
Standard	CFR47 Part 15.109, Class A						RBW / VBW	See Note				
Dist/Ant Used	3m / JB3 & EMCO3115						Performed by	Jeremy Luong				
Emission Freq (MHz)	ANT Polar (H/V)	ANT Pos (cm)	Table Pos (deg)	FIM (Pk) (dBuV/m)	FIM QP/Ave (dBuV/m)	Total CF (dBuV)	E-Field QP/Ave (dBuV/m)	Spec Limit (dBuV/m)	Spec Margin (dB)	Type		
Receive Mode												
121.59	H	190	97	45.18	41.49	-9.70	31.79	53.98	-22.19	Spurious		
500.02	H	141	5	49.07	46.50	-5.26	41.24	56.90	-15.66	Spurious		
625.03	H	117	148	46.16	44.35	-3.08	41.27	56.90	-15.63	Spurious		
750.07	H	103	135	45.85	40.50	-0.62	39.88	56.90	-17.02	Spurious		
871.23	H	142	264	47.24	45.27	0.80	46.07	56.90	-10.83	Spurious		
874.16	H	144	242	48.24	47.14	0.76	47.90	56.90	-9.00	Spurious		
120.95	V	117	78	44.38	41.49	-9.97	31.52	53.98	-22.46	Spurious		
399.99	V	120	25	48.08	46.76	-7.15	39.61	56.90	-17.29	Spurious		
500.02	V	113	163	47.45	43.94	-5.66	38.28	56.90	-18.62	Spurious		
750.06	V	108	114	41.70	35.75	-1.22	34.53	56.90	-22.37	Spurious		
871.24	V	116	42	46.76	44.78	0.25	45.03	56.90	-11.87	Spurious		
874.33	V	142	54	45.99	43.90	0.33	44.23	56.90	-12.67	Spurious		
1495.67	H	128	138	58.97	40.12	-7.69	32.43	60.00	-27.57	Spurious		
1595.60	H	124	147	59.78	39.72	-6.83	32.89	60.00	-27.11	Spurious		
1861.15	H	99	174	57.38	44.24	-4.94	39.30	60.00	-20.70	Spurious		
2392.13	H	168	183	56.77	35.18	-3.01	32.17	60.00	-27.83	Spurious		
Spec Margin = E-Field QP - Limit, E-Field QP = FIM QP+ Total CF ± Uncertainty												
Total CF= Amp Gain + Cable Loss + ANT Factor												
Combined Standard Uncertainty $u_c(y) = \pm 3.2\text{dB}$ Expanded Uncertainty $U = ku_c(y)$ $k = 2$ for 95% confidence												
Notes: Tested on the Y-Axis at Ch 6.												
30 MHz – 1GHz: RBW=120 kHz, VBW=300 kHz												
1GHz – 25 GHz: RBW=1MHz, VBW=3MHz												

SOP 1 Radiated Emissions

Tracking # 31053887.001 Page 8 of 12

EUT Name	OPTIVIEW XG, OPVXG, OPTIVIEW XG-10G, OPVXG-10G, OPVXGPRO, OPVXG-EXPT, OPTIVIEW XG-LAN, OPVXG-LAN, OPVXG-LAN-10G, OPTIVIEW XG WLAN, OPVXG-WLAN	Date	January 24, 2011
EUT Model	3365336, 3949539, 3949542, 3949556, 3949616, 4020634	Temp / Hum in	22°C / 40%rh
EUT Serial	Prototype	Temp / Hum out	N/A
EUT Config.	Y-Axis, 802.11n HT20, RX at Ch6, 19.5Mbps	Line AC	120Vac 60Hz
Standard	Prototype	RBW / VBW	120 kHz / 300 kHz
Dist/Ant Used	3m / JB3	Performed by	Jeremy Luong

30 MHz to 1000 MHz Plots for Receive Mode

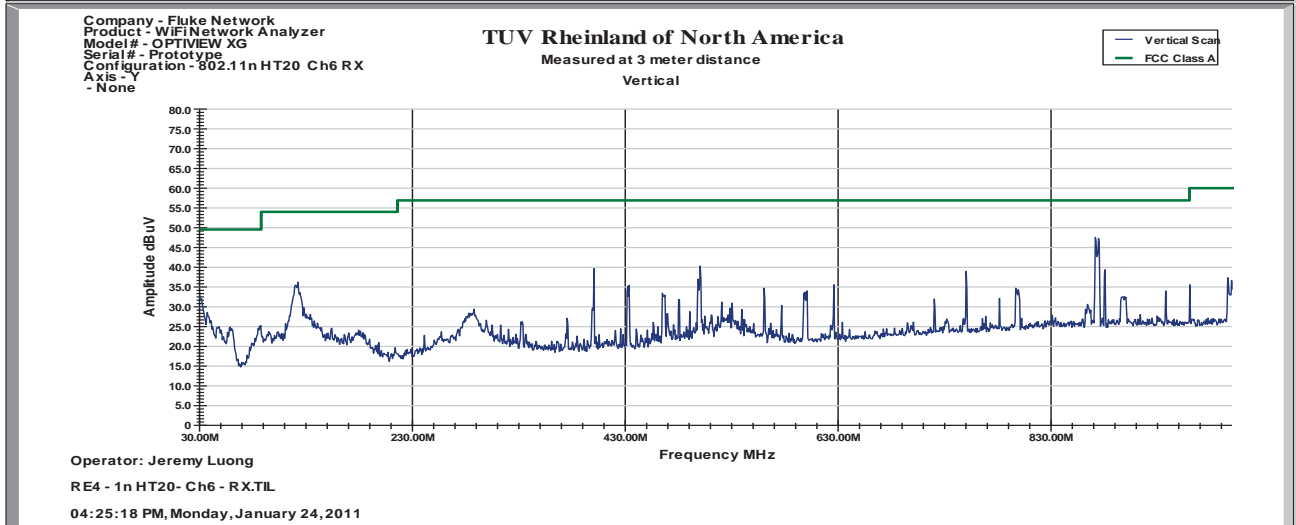
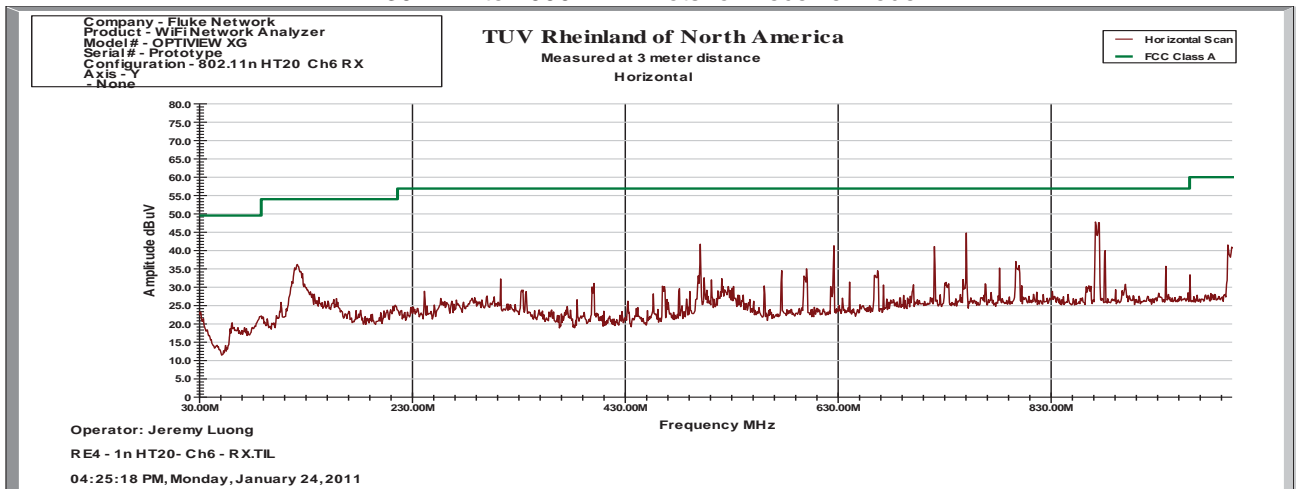

Notes: None.

SOP 1 Radiated Emissions

Tracking # 31053887.001 Page 9 of 12

EUT Name	OPTIVIEW XG, OPVXG, OPTIVIEW XG-10G, OPVXG-10G, OPVXGPRO, OPVXG-EXPT, OPTIVIEW XG-LAN, OPVXG-LAN, OPVXG-LAN-10G, OPTIVIEW XG WLAN, OPVXG-WLAN	Date	January 21, 2011
EUT Model	3365336, 3949539, 3949542, 3949556, 3949616, 4020634	Temp / Hum in	23°C / 40%rh
EUT Serial	Prototype	Temp / Hum out	N/A
EUT Config.	Y-Axis, 802.11n HT20, RX at Ch6, 19.5Mbps	Line AC	120Vac 60Hz
Standard	CFR47 Part 15.109, Class A	RBW / VBW	1MHz / 3MHz
Dist/Ant Used	3m / EMCO3115	Performed by	Jeremy Luong

Above 1GHz Plot for Receive Mode

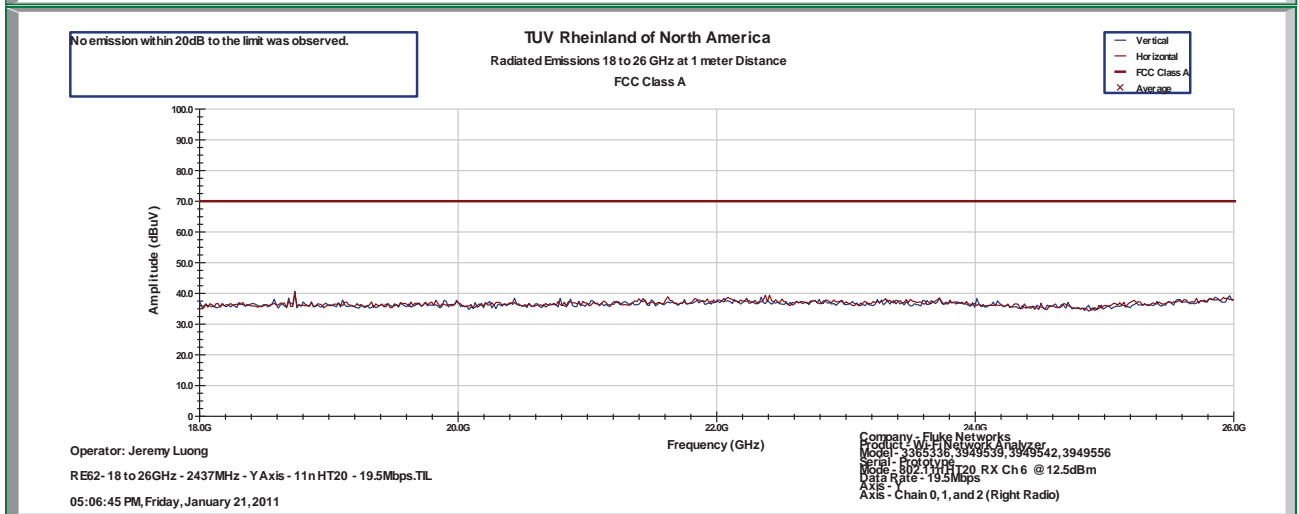
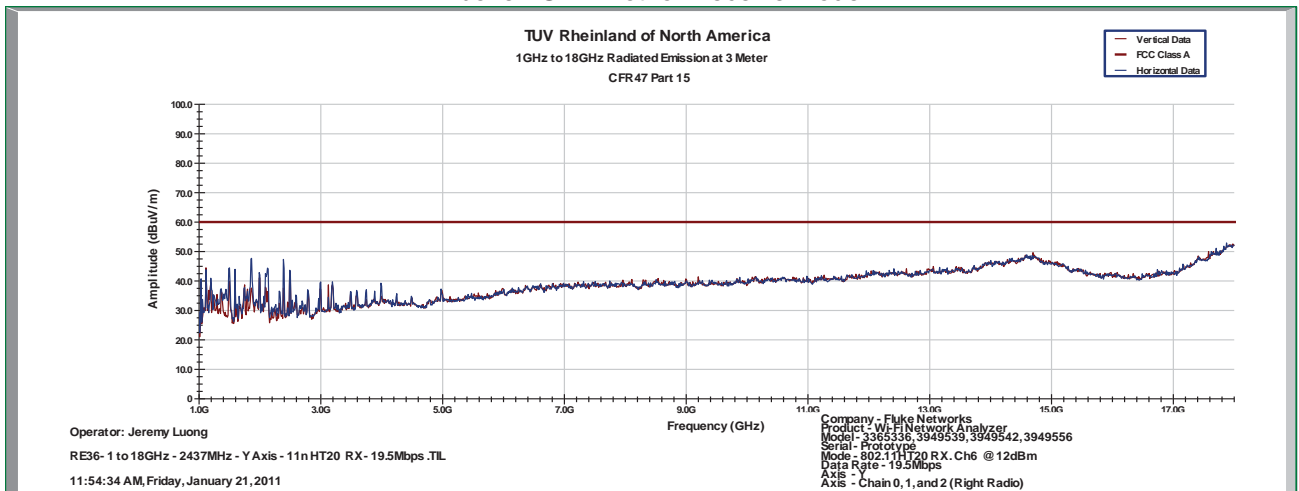

Notes: None.

SOP 1 Radiated Emissions											Tracking # 31053887.001 Page 10 of 12
EUT Name		OPTIVIEW XG, OPVXG, OPTIVIEW XG-10G, OPVXG-10G, OPVXGPRO, OPVXG-EXPT, OPTIVIEW XG-LAN, OPVXG-LAN, OPVXG-LAN-10G, OPTIVIEW XG WLAN, OPVXG-WLAN					Date		January 25, 2011		
EUT Model		3365336, 3949539, 3949542, 3949556, 3949616, 4020634					Temp / Hum in		21°C / 39%rh		
EUT Serial		Prototype					Temp / Hum out		N/A		
EUT Config.		Y-Axis, 802.11n HT40, RX at Ch6, 40.5Mbps					Line AC / Freq		120Vac 60Hz		
Standard		CFR47 Part 15.109, Class A					RBW / VBW		See Note		
Dist/Ant Used		3m / JB3 & EMCO3115					Performed by		Jeremy Luong		
Emission Freq (MHz)	ANT Polar (H/V)	ANT Pos (cm)	Table Pos (deg)	FIM (Pk) (dBuV/m)	FIM QP (dBuV/m)	Total CF (dBuV)	E-Field QP (dBuV/m)	Spec Limit (dBuV/m)	Spec Margin (dB)	Type	
Receive Mode											
119.99	H	284	258	45.69	41.85	-9.78	32.07	53.98	-21.91	Spurious	
500.04	H	161	139	48.26	44.37	-5.26	39.11	56.90	-17.79	Spurious	
625.03	H	126	149	44.97	43.03	-3.08	39.95	56.90	-16.95	Spurious	
720.00	H	103	344	43.19	42.71	-1.14	41.57	56.90	-15.33	Spurious	
750.05	H	103	126	45.45	40.01	-0.62	39.39	56.90	-17.51	Spurious	
871.27	H	233	276	45.95	43.94	0.80	44.74	56.90	-12.16	Spurious	
874.17	H	141	242	47.57	46.89	0.76	47.65	56.90	-9.25	Spurious	
120.25	V	126	82	44.20	41.45	-9.98	31.47	53.98	-22.51	Spurious	
399.99	V	129	7	48.59	43.03	-7.15	35.88	56.90	-21.02	Spurious	
500.02	V	105	298	46.18	46.15	-5.66	40.49	56.90	-16.41	Spurious	
871.21	V	109	298	47.27	45.19	0.25	45.44	56.90	-11.46	Spurious	
874.19	V	113	281	45.35	44.19	0.32	44.51	56.90	-12.39	Spurious	
1495.67	H	128	138	58.97	40.12	-7.69	32.43	53.98	-21.55	Spurious	
1595.60	H	124	147	59.78	39.72	-6.83	32.89	53.98	-21.09	Spurious	
1861.15	H	99	174	57.38	44.24	-4.94	39.30	53.98	-14.68	Spurious	
2392.13	H	168	183	56.77	35.18	-3.01	32.17	53.98	-21.81	Spurious	
Spec Margin = E-Field QP - Limit, E-Field QP = FIM QP+ Total CF ± Uncertainty											
Total CF= Amp Gain + Cable Loss + ANT Factor											
Combined Standard Uncertainty $u_c(y) = \pm 3.2\text{dB}$ Expanded Uncertainty $U = ku_c(y)$ $k = 2$ for 95% confidence											
Notes: Tested on the Y-Axis at Ch 6.											
30 MHz – 1GHz: RBW=120 kHz, VBW=300 kHz											
1GHz – 25 GHz: RBW=1MHz, VBW=3MHz											

SOP 1 Radiated Emissions

Tracking # 31053887.001 Page 11 of 12

EUT Name	OPTIVIEW XG, OPVXG, OPTIVIEW XG-10G, OPVXG-10G, OPVXGPRO, OPVXG-EXPT, OPTIVIEW XG-LAN, OPVXG-LAN, OPVXG-LAN-10G, OPTIVIEW XG WLAN, OPVXG-WLAN	Date	January 26, 2011
EUT Model	3365336, 3949539, 3949542, 3949556, 3949616, 4020634	Temp / Hum in	21°C / 38%rh
EUT Serial	Prototype	Temp / Hum out	N/A
EUT Config.	Y-Axis, 802.11n HT40, RX at Ch6, 40.5Mbps	Line AC	120Vac 60Hz
Standard	CFR47 Part 15.109, Class A	RBW / VBW	120 kHz / 300 kHz
Dist/Ant Used	3m / JB3	Performed by	Jeremy Luong

30 MHz to 1000 MHz Plots for Receive Mode

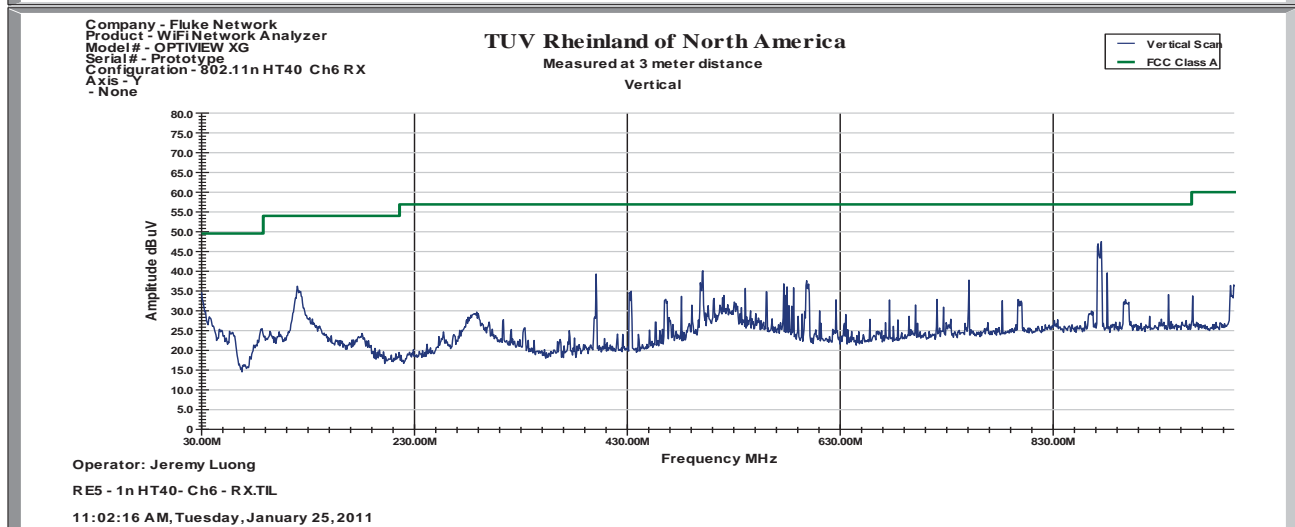
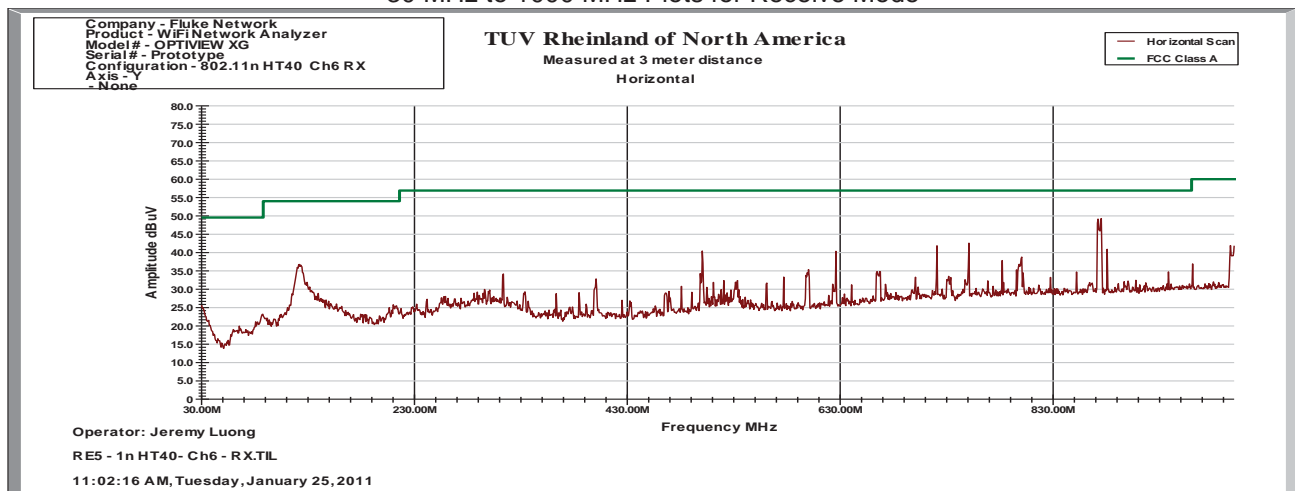

Notes: None.

SOP 1 Radiated Emissions

Tracking # 31053887.001 Page 12 of 12

EUT Name	OPTIVIEW XG, OPVXG, OPTIVIEW XG-10G, OPVXG-10G, OPVXGPRO, OPVXG-EXPT, OPTIVIEW XG-LAN, OPVXG-LAN, OPVXG-LAN-10G, OPTIVIEW XG WLAN, OPVXG-WLAN	Date	January 21, 2011
EUT Model	3365336, 3949539, 3949542, 3949556, 3949616, 4020634	Temp / Hum in	23°C / 40%rh
EUT Serial	Prototype	Temp / Hum out	N/A
EUT Config.	Y-Axis, 802.11n HT40, RX at Ch6, 40.5Mbps	Line AC	120Vac 60Hz
Standard	CFR47 Part 15.109, Class A	RBW / VBW	1MHz / 3MHz
Dist/Ant Used	3m / EMCO3115	Performed by	Jeremy Luong

Above 1GHz Plot for Receive Mode

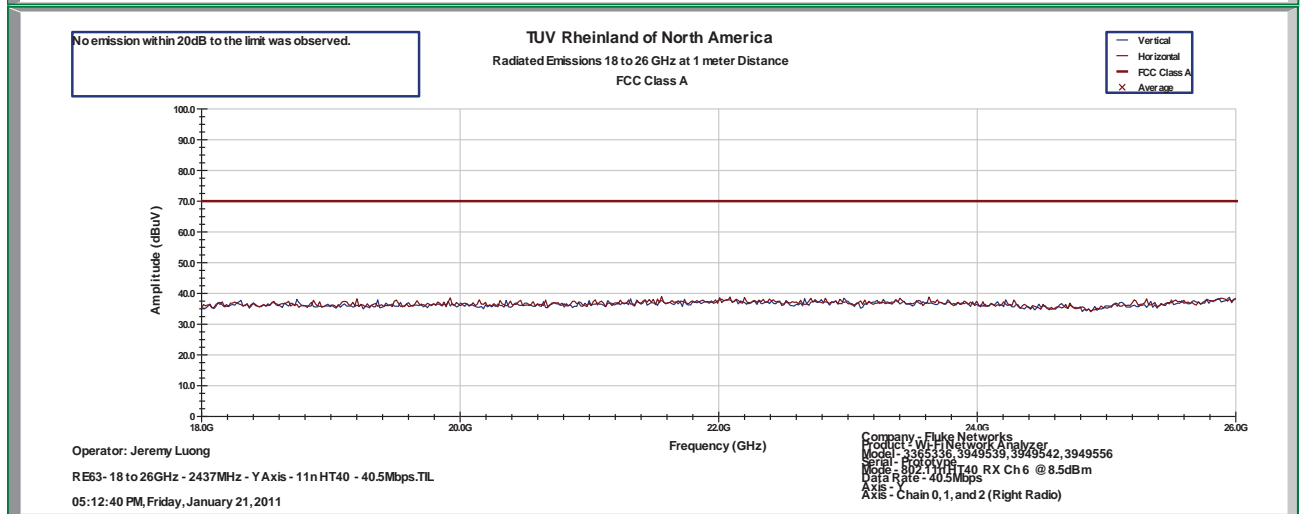
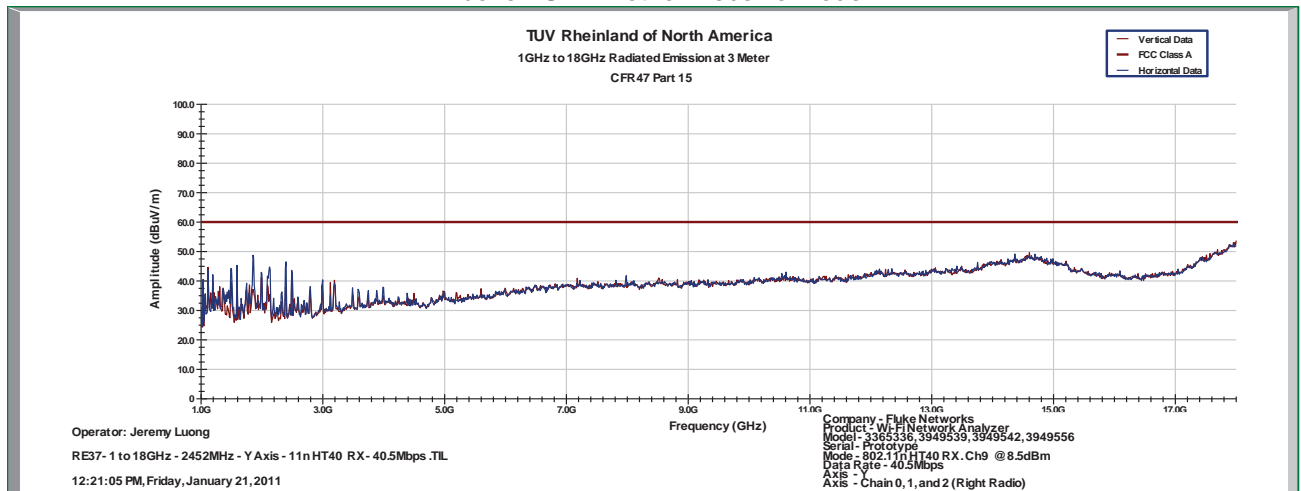

Notes: None.

4.6.4 Sample Calculation

The field strength is calculated by subtracting the Amplifier Gain and adding the Cable Loss and Antenna Correction Factor to the measured reading. The basic equation is as follows:

$$\text{Field Strength (dB}\mu\text{V/m)} = \text{FIM} - \text{AMP} + \text{CBL} + \text{ACF}$$

Where: FIM = Field Intensity Meter (dB μ V)
AMP = Amplifier Gain (dB)
CBL = Cable Loss (dB)
ACF = Antenna Correction Factor (dB/m)

$$\mu\text{V/m} = 10^{\frac{\text{dB}\mu\text{V/m}}{20}}$$

4.7 AC Conducted Emissions

Testing was performed in accordance with ANSI C63.4-2009. These test methods are listed under the laboratory's NVLAP Scope of Accreditation.

This test measures the levels emanating from the EUT's AC input port, thus evaluating the potential for the EUT to cause radio frequency interference to other electronic devices.

The AC conducted emissions of equipment under test shall not exceed the values in CFR47 Part 15.207: 2009 and RSS 210: 2010.

4.7.1 Test Methodology

A test program that controls instrumentation and data logging was used to automate the AC Power Line Conducted emission test procedure. The frequency range of interest was divided into sub-ranges such as to yield a frequency resolution of 9 kHz. Each phase and neutral of the AC power line were measured with respect to ground. Measurements were performed using a set of 50 μ H / 50 Ω LISNs.

Testing is either performed in Lab 5. The setup photographs clearly identify which site was used. The vertical ground plane used in the semi-anechoic chamber is a 2m x 2m solid aluminum frame and panel, and it is bonded to the horizontal ground plane.

In the case of tabletop equipment, the EUT is placed on a 1.0m x 1.5m non-conductive table 80cm above the ground plane and 40cm from a vertical ground reference plane. The rear of the EUT was positioned flush with the backside of the table and directly over the LISNs. The power and I/O cables were routed over the edge of the table and bundled approximately 40cm from the ground plane. Support equipment was powered from a separate LISN.

4.7.1.1 Deviations

There were no deviations from this test methodology.

4.7.2 Test Results

As originally tested, the EUT was found to be compliant to the requirements of the test standard(s).

Table 8: AC Conducted Emissions – Test Results

Test Conditions: Conducted Measurement at Normal Conditions only		
Antenna Type: Attached		Power Level: See Test Plan
AC Power: 120 Vac/60 Hz		Configuration: Tabletop
Ambient Temperature: 22 ^o C		Relative Humidity: 38% RH
Configuration	Frequency Range	Test Result
Line 1 (Hot)	0.15 to 30 MHz	Pass

Line 2 (Neutral)	0.15 to 30 MHz	Pass
------------------	----------------	------

Frequency	Quasi-Peak	QP Limit	QP Margin	Average	Ave Limit	Ave Margin
MHz	dBuV	dBuV	dB	dBuV	dBuV	dB
0.150	48.39	66.00	-17.61	41.84	56.00	-14.16
0.151	48.20	66.00	-17.80	41.81	56.00	-14.19
0.198	28.12	64.64	-36.52	-3.57	54.64	-58.21
0.198	28.38	64.63	-36.25	-3.10	54.63	-57.73
10.714	38.57	60.00	-21.43	32.49	50.00	-17.51
10.832	39.68	60.00	-20.32	33.55	50.00	-16.45
10.913	40.01	60.00	-19.99	34.06	50.00	-15.94
15.440	37.26	60.00	-22.74	31.38	50.00	-18.62
16.041	37.20	60.00	-22.80	31.41	50.00	-18.59

Spec Margin = QP./Ave. - Limit, ± Uncertainty
 Combined Standard Uncertainty $u_c(y) = \pm 1.2$ dB Expanded Uncertainty $U = k u_c(y)$ $k = 2$ for 95% confidence
 Notes: EUT was setup as table top equipment.

SOP 2 Conducted Emissions

Tracking # 31053887.001 Page 2 of 4

EUT Name	OPTIVIEW XG, OPVXG, OPTIVIEW XG-10G, OPVXG-10G, OPVXGPRO, OPVXG-EXPT, OPTIVIEW XG-LAN, OPVXG-LAN, OPVXG-LAN-10G, OPTIVIEW XG WLAN, OPVXG-WLAN	Date	January 27, 2011
EUT Model	3365336, 3949539, 3949542, 3949556, 3949616, 4020634	Temp / Hum in	21° C / 38% rh
EUT Serial	Prototype	Temp / Hum out	N/A
EUT Config.	Attached Antenna	Line AC	120Vac/60Hz
Standard	CFR47 Part 15.207	RBW / VBW	9kHz / 30 kHz
Lab/LISN	Lab #5 / Solar 9348-50-R-24-BNC, Line 1	Performed by	Jeremy Luong

150 kHz to 30 MHz Plot for Line 1 (Hot)

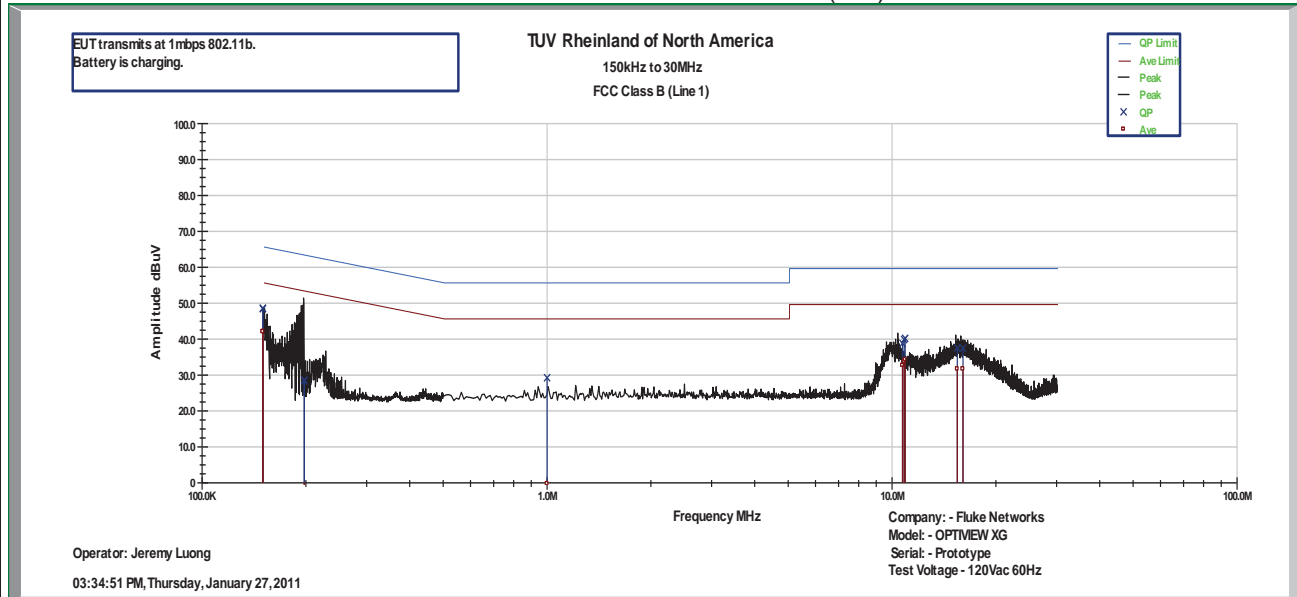

Notes: Meet FCC Class B limit.

SOP 2 Conducted Emissions				Tracking # 31053887.001 Page 3 of 4		
EUT Name	OPTIVIEW XG, OPVXG, OPTIVIEW XG-10G, OPVXG-10G, OPVXGPRO, OPVXG-EXPT, OPTIVIEW XG-LAN, OPVXG-LAN, OPVXG-LAN-10G, OPTIVIEW XG WLAN, OPVXG-WLAN			Date	January 27, 2011	
EUT Model	3365336, 3949539, 3949542, 3949556, 3949616, 4020634			Temp / Hum in	21° C / 38% rh	
EUT Serial	Prototype			Temp / Hum out	N/A	
EUT Config.	Attached Antenna			Line AC / Freq	120Vac/60Hz	
Standard	CFR47 Part 15.107			RBW / VBW	9kHz / 30 kHz	
Lab/LISN	Lab #5 / Solar 9348-50-R-24-BNC, Line 2			Performed by	Jeremy Luong	
Frequency	Quasi-Peak	QP Limit	QP Margin	Average	Ave Limit	Ave Margin
MHz	dBuV	dBuV	dB	dBuV	dBuV	dB
0.151	44.06	65.96	-21.90	28.66	55.96	-27.30
0.153	43.39	65.92	-22.53	26.01	55.92	-29.91
0.196	46.09	64.69	-18.60	23.73	54.69	-30.96
0.198	29.24	64.63	-35.39	-3.63	54.63	-58.26
0.198	29.21	64.63	-35.42	-3.25	54.63	-57.88
10.009	32.37	60.00	-27.63	26.24	50.00	-23.76
10.251	34.93	60.00	-25.07	28.76	50.00	-21.24
15.469	39.14	60.00	-20.86	33.33	50.00	-16.67
15.565	39.28	60.00	-20.72	33.45	50.00	-16.55
Spec Margin = QP./Ave. - Limit, ± Uncertainty						
Combined Standard Uncertainty $u_c(y) = \pm 1.2$ dB Expanded Uncertainty $U = ku_c(y)$ $k = 2$ for 95% confidence						
Notes: EUT was setup as table top equipment.						

SOP 2 Conducted Emissions

Tracking # 31053887.001 Page 4 of 4

EUT Name	OPTIVIEW XG, OPVXG, OPTIVIEW XG-10G, OPVXG-10G, OPVXGPRO, OPVXG-EXPT, OPTIVIEW XG-LAN, OPVXG-LAN, OPVXG-LAN-10G, OPTIVIEW XG WLAN, OPVXG-WLAN	Date	January 27, 2011
EUT Model	3365336, 3949539, 3949542, 3949556, 3949616, 4020634	Temp / Hum in	21° C / 38% rh
EUT Serial	Prototype	Temp / Hum out	N/A
EUT Config.	Attached Antenna	Line AC	120Vac/60Hz
Standard	CFR47 Part 15.107	RBW / VBW	9kHz / 30 kHz
Lab/LISN	Lab #5/ Solar 9348-50-R-24-BNC, Line 2	Performed by	Jeremy Luong

150 kHz to 30 MHz Plot for Line 2 (Neutral)

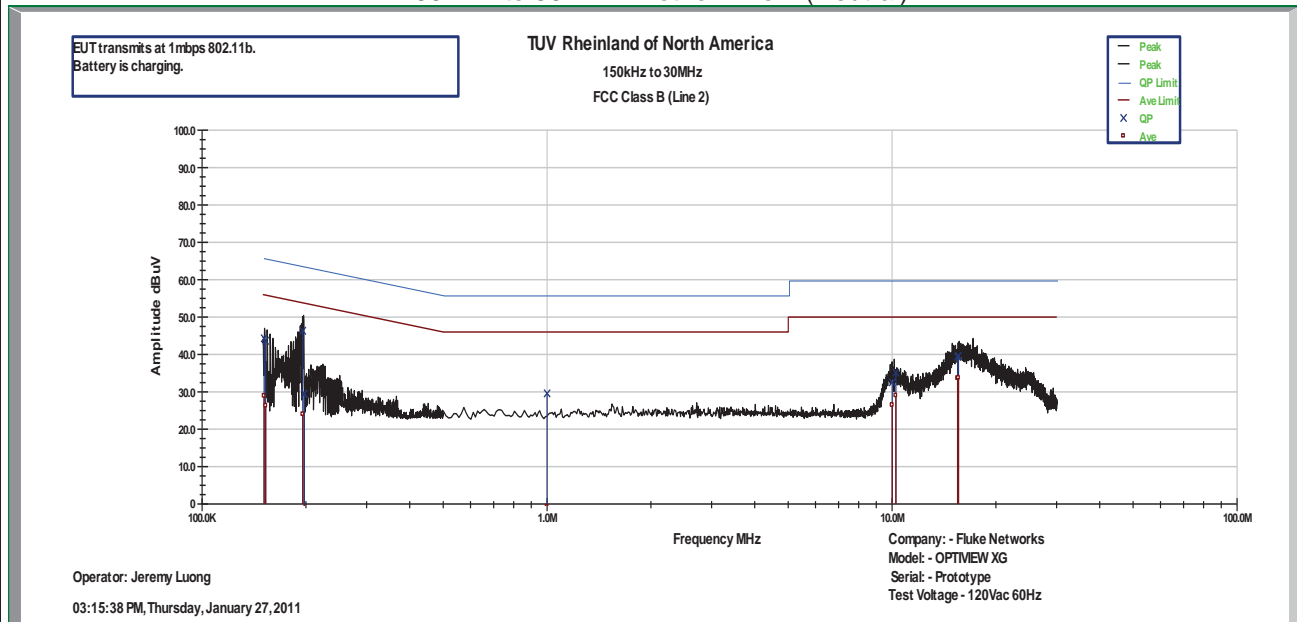

Note: Meet FCC Class B Limit.

5 Emission Requirements – 5725 MHz to 5850 MHz Band

Testing was performed in accordance with CFR 47 Part 15.247: 2009 and RSS 210 Annex 8: 2010. These test methods are listed under the laboratory’s NVLAP Scope of Accreditation. This test measures the levels emanating from the EUT, thus evaluating the potential for the EUT to cause radio frequency interference to other electronic devices. Procedures described in section 8 of the standard were used.

5.1 Output Power Requirements

The maximum output power requirement is the maximum equivalent isotropic radiated power delivering at the transmitting antenna under specified conditions of measurements in the presence of modulation.

The maximum output power and harmonics shall not exceed CFR47 Part 15.247 (b3):2009 and RSS 210 A.8.4: 2010

The maximum transmitted power is +30 dBm or 1Watt.

5.1.1 Test Method

The conducted method was used to measure the channel power output according to ANSI C63.10:2009 Section 6.10.3.1. The measurement was performed with modulation per CFR47 Part 15.247 (b3):2009 and RSS 210 A.8.4. This test was conducted on 3 channels in each operating mode. The worst mode result indicated below.

Test Setup:

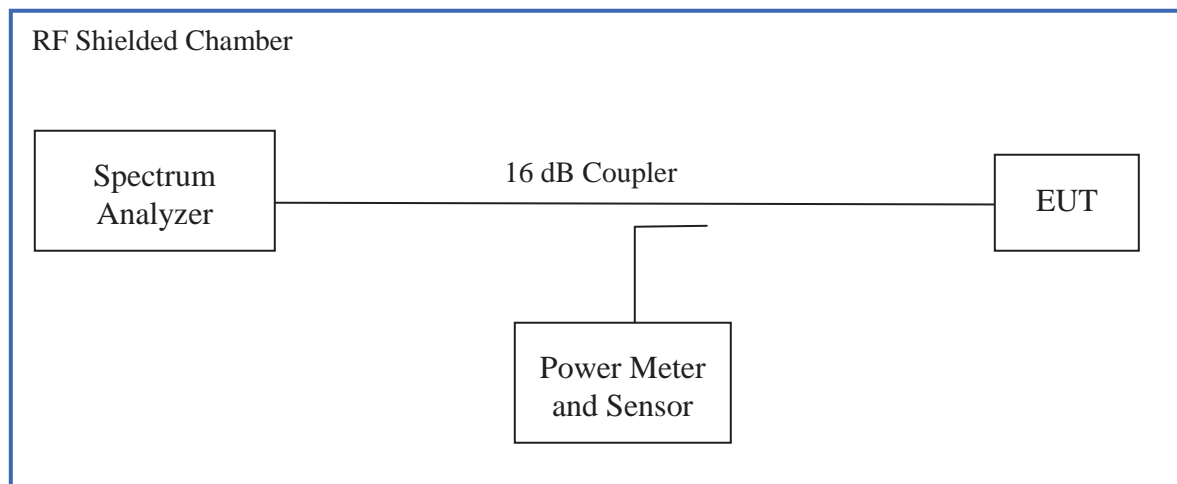

Method #1 of “Measurement of Digital Transmission Systems Operating under Section 15.247” applies since the EUT continuously transmit; where T, Transmission Duration Pulse, is greater than analyzer sweep time. Peak detector was used.

Each chain was measured individually and applied the measure-and-sum approach per KDB662911.

5.1.2 Results

As originally tested, the EUT was found to be compliant to the requirements of the test standard(s).

Table 9: RF Output Power at the Antenna Port – Test Results

Test Conditions: Conducted Measurement, Normal Temperature						
Antenna Type: Integrated				Power Setting: See Test Plan		
Max. Antenna Gain: + 3.2 dBi				Signal State: Modulated at 100%		
Ambient Temp.: 22 °C				Relative Humidity: 44%		
802.11a Mode						
Operating Channel	Limit [dBm]	Chain 0 [dBm]	Chain 1 [dBm]	Chain 2 [dBm]	Total Power [dBm]	Margin [dB]
5745MHz	+30.00	18.40	21.67	22.28		-7.72
5785MHz	+30.00	18.94	21.58	22.42		-7.58
5825MHz	+30.00	19.06	21.22	22.69		-7.31
Note: The highest output power was observed at 24 Mbps. Only one chain will be active at one time.						
802.11n (HT20) Mode, 1x3						
Operating Channel	Limit [dBm]	Chain 0 [dBm]	Chain 1 [dBm]	Chain 2 [dBm]	Total Power [dBm]	Margin [dB]
5745MHz	+30.00	22.12	22.31	22.93		-7.07
5785MHz	+30.00	22.48	22.26	23.04		-6.96
5825MHz	+30.00	22.43	21.97	23.16		-6.84
Note: The highest output power was observed at HT20 6.5 Mbps, 1 Data Stream. Only one chain will be active at one time.						
802.11n (HT20) Mode, 2x3						
Operating Channel	Limit [dBm]	Chain 0 [dBm]	Chain 1 [dBm]	Chain 2 [dBm]	Total Power [dBm]	Margin [dB]
5745MHz	+30.00	20.33	21.16		23.78	-6.22
5785MHz	+30.00	20.39	20.38		23.40	-6.60
5825MHz	+30.00	19.80	20.09		22.96	-7.04
Note: The highest output power was observed at HT20 13 Mbps, 2 Data Stream.						

802.11n (HT20) Mode, 3x3						
Operating Channel	Limit [dBm]	Chain 0 [dBm]	Chain 1 [dBm]	Chain 2 [dBm]	Total Power [dBm]	Margin [dB]
5745MHz	+30.00	20.10	20.99	20.28	25.25	-4.75
5785MHz	+30.00	19.36	20.44	20.63	24.95	-5.05
5825MHz	+30.00	18.88	20.22	20.66	24.75	-5.25
Note: The highest output power was observed at HT20 19.5 Mbps, 3 Data Stream.						
802.11n (HT40) Mode, 1x3						
Operating Channel	Limit [dBm]	Chain 0 [dBm]	Chain 1 [dBm]	Chain 2 [dBm]	Total Power [dBm]	Margin [dB]
5755MHz	+30.00	18.90	20.66	21.49		-8.51
5795MHz	+30.00	20.17	20.92	21.72		-8.28
Note: The highest output power was observed at HT40 81 Mbps, 1 Data Stream. Only one chain will be active at one time.						
802.11n (HT40) Mode, 2x3						
Operating Channel	Limit [dBm]	Chain 0 [dBm]	Chain 1 [dBm]	Chain 2 [dBm]	Total Power [dBm]	Margin [dB]
5755MHz	+30.00	18.18	19.53		21.92	-8.08
5795MHz	+30.00	18.27	19.51		21.94	-8.06
Note: The highest output power was observed at HT40 27 Mbps, 2 Data Stream						
802.11n (HT40) Mode, 3x3						
Operating Channel	Limit [dBm]	Chain 0 [dBm]	Chain 1 [dBm]	Chain 2 [dBm]	Total Power [dBm]	Margin [dB]
5755MHz	+30.00	18.54	18.77	19.03	23.56	-6.44
5795MHz	+30.00	18.92	19.02	19.23	23.83	-6.17
Note: The highest output power was observed at HT40 40.5 Mbps, 3 Data Stream.						

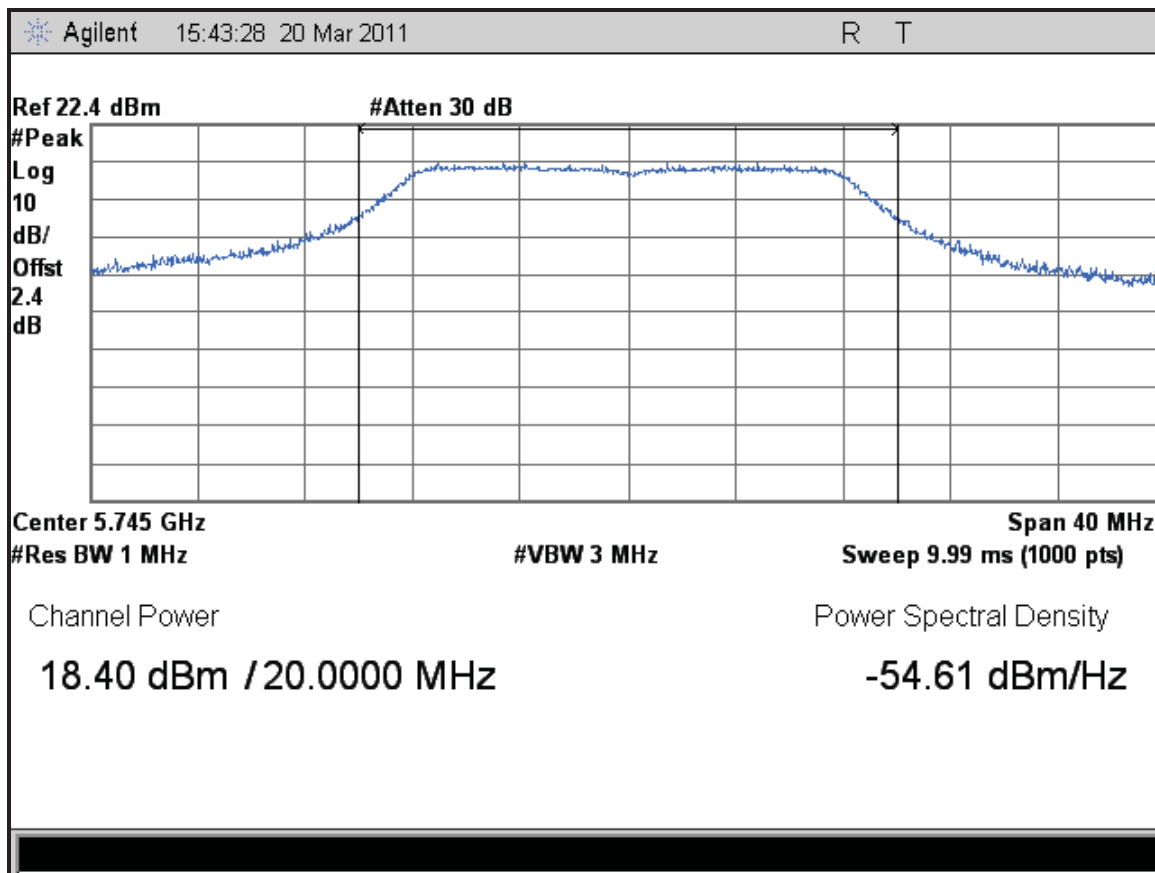

Figure 373: Maximum Transmitted Power, Lowest Channel 5745 MHz of 802.11a, Chain 0

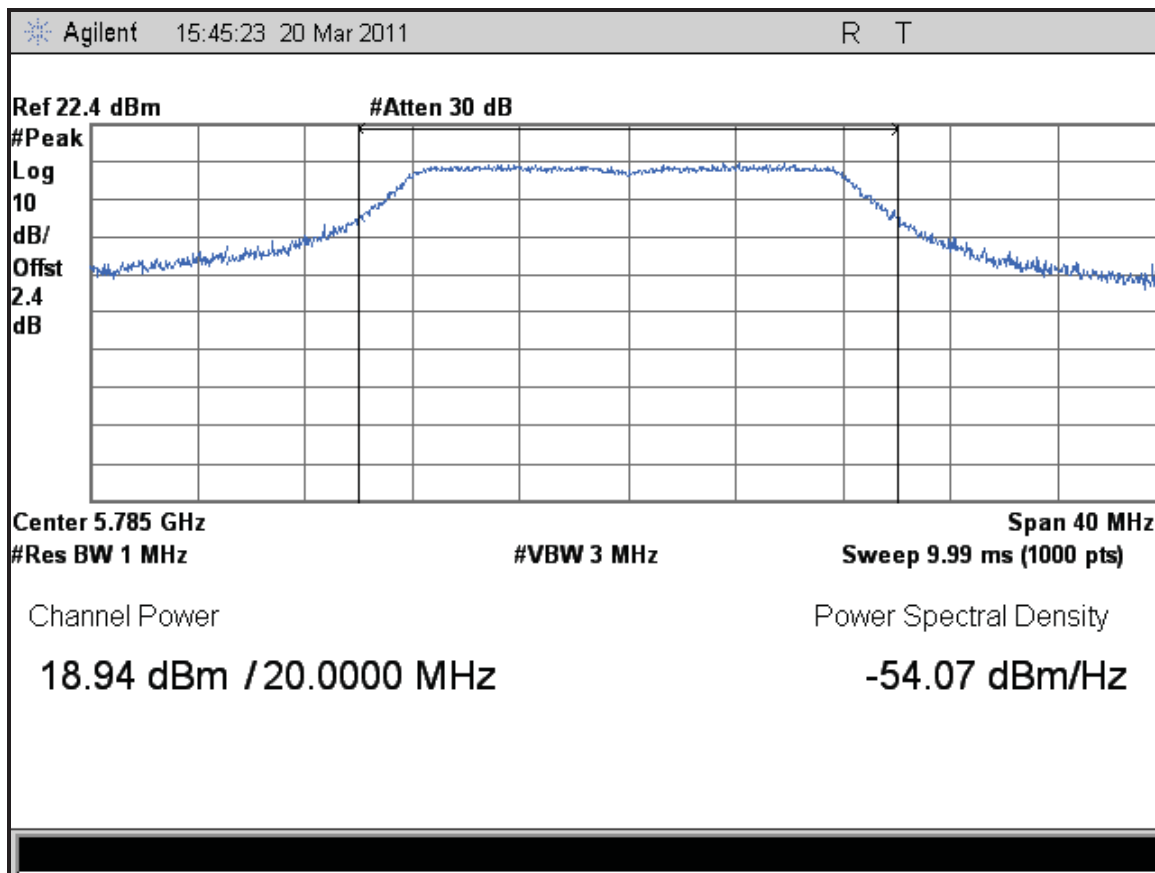

Figure 374: Maximum Transmitted Power, Middle Channel 5785 MHz of 802.11a, Chain 0

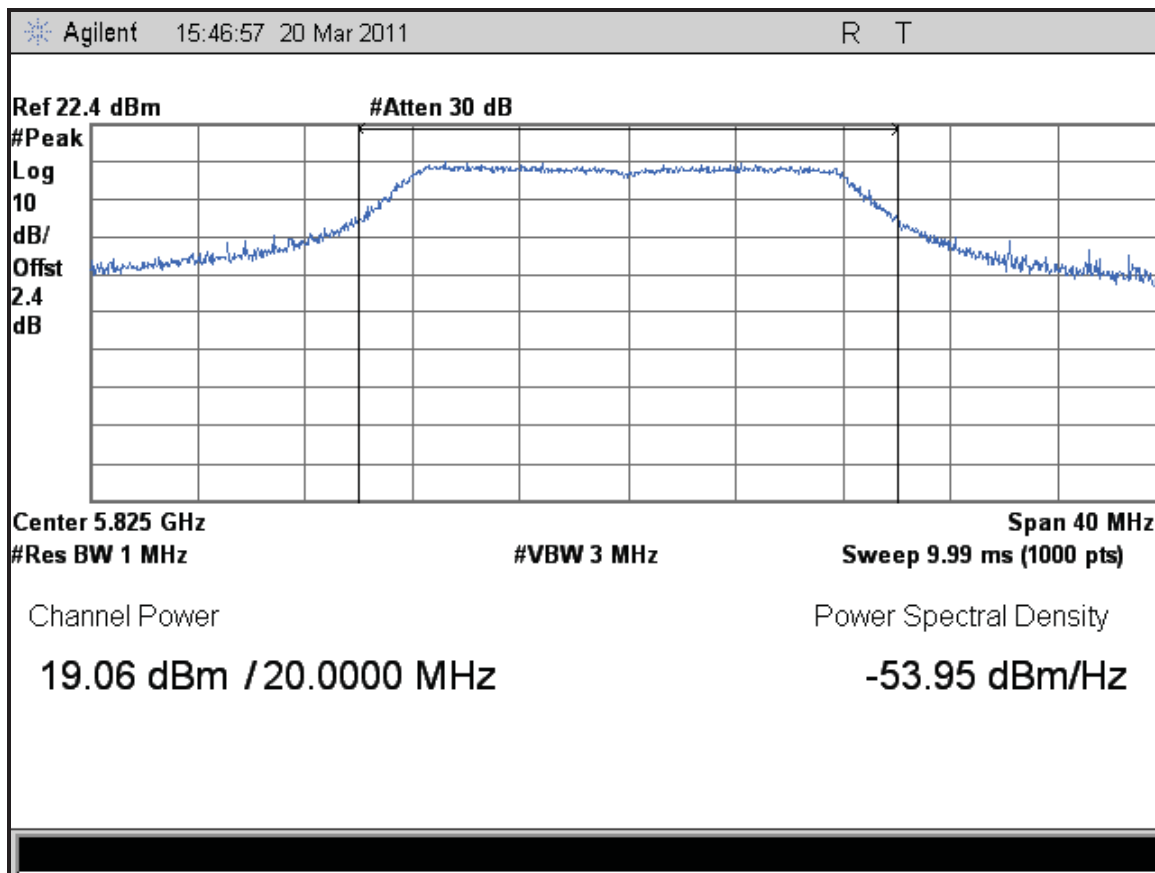

Figure 375: Maximum Transmitted Power, Highest Channel 5825 MHz of 802.11a, Chain 0

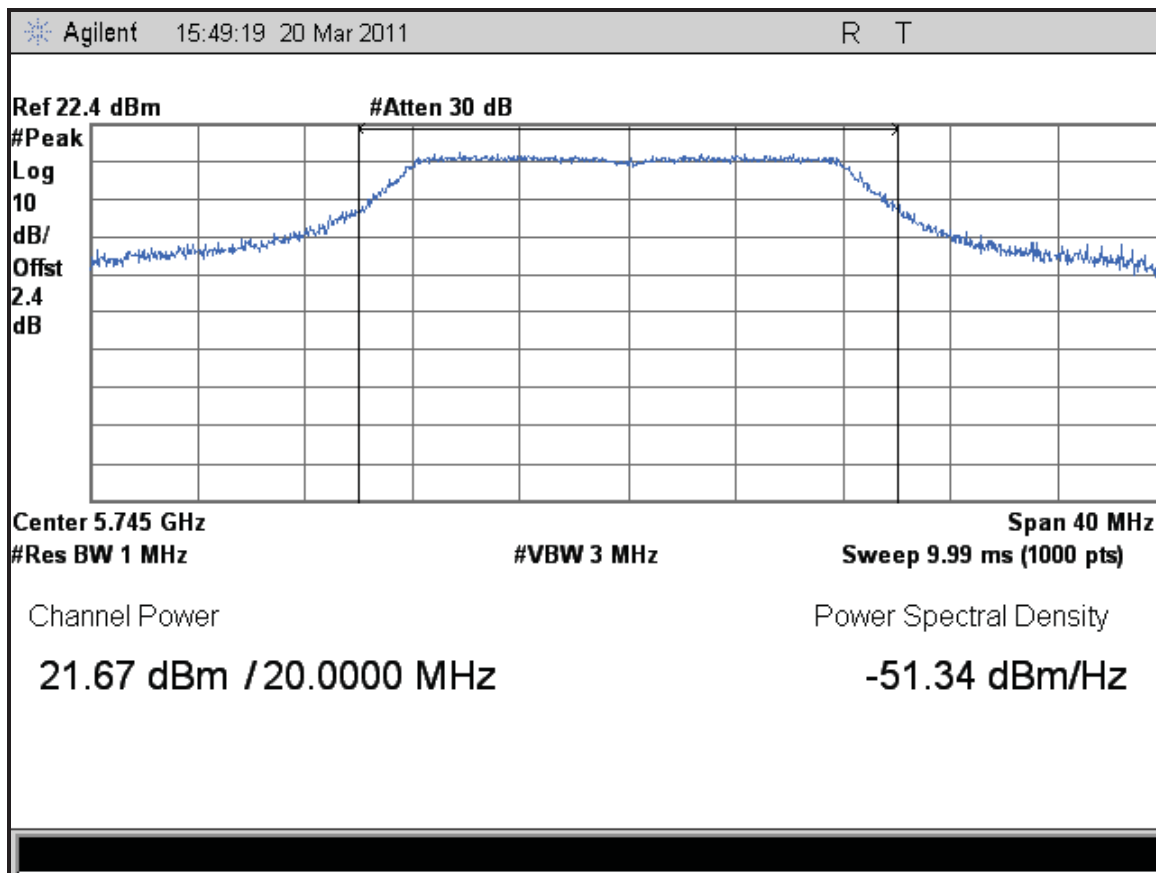

Figure 376: Maximum Transmitted Power, Lowest Channel 5745 MHz of 802.11a, Chain 1

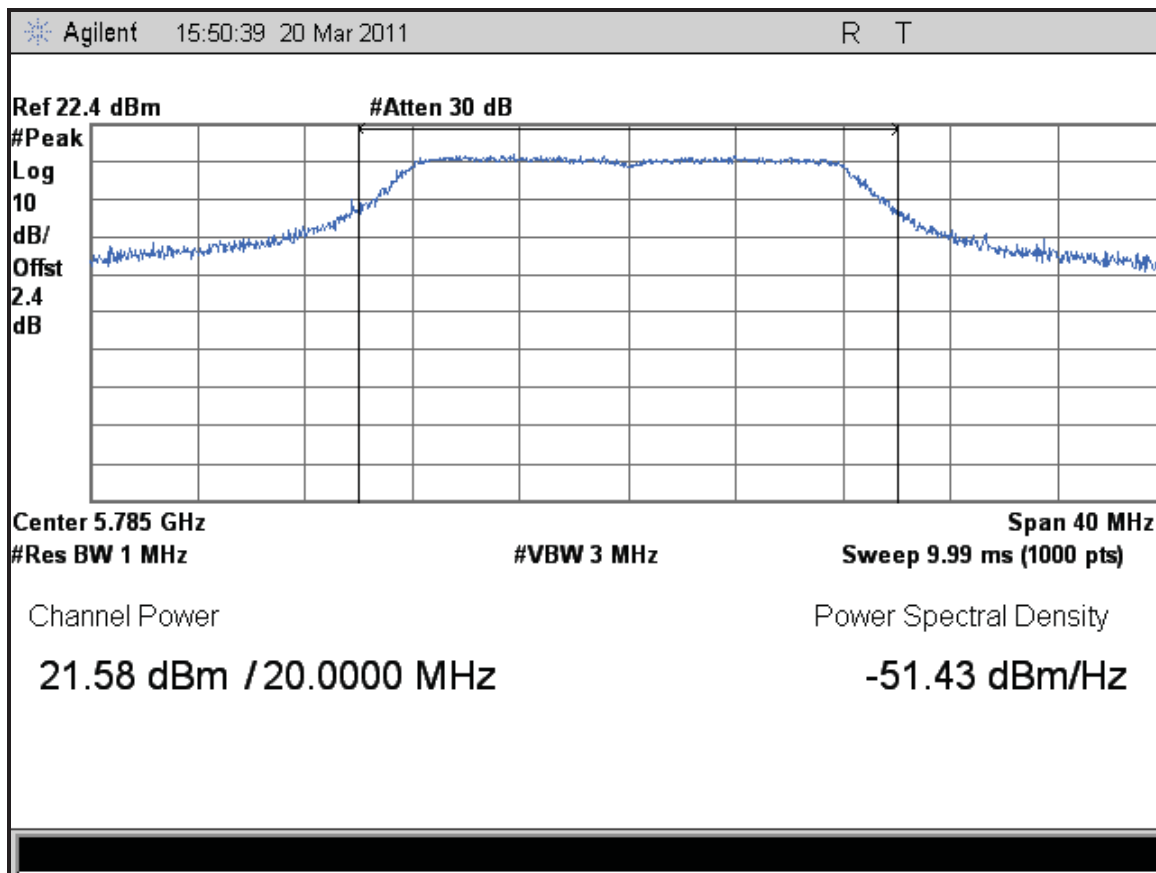

Figure 377: Maximum Transmitted Power, Middle Channel 5785 MHz of 802.11a, Chain 1

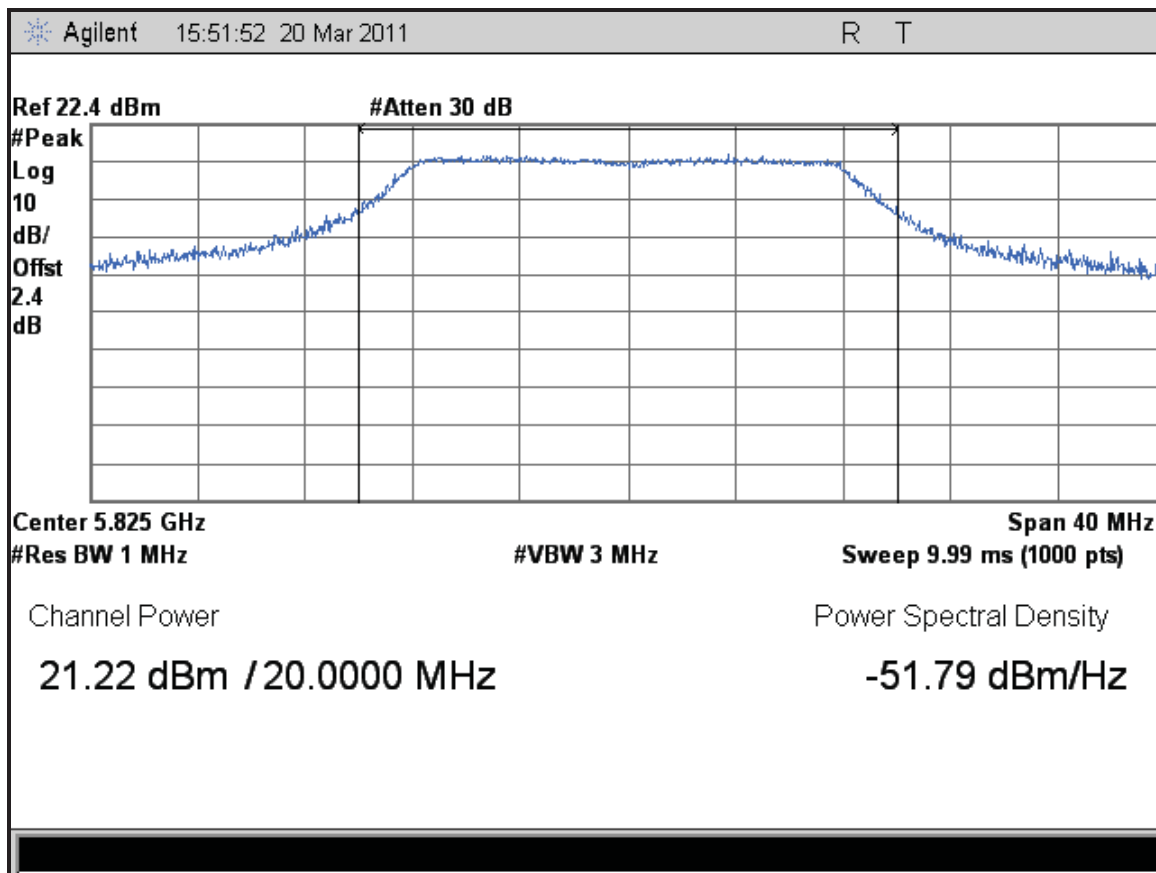

Figure 378: Maximum Transmitted Power, Highest Channel 5825 MHz of 802.11a, Chain 1

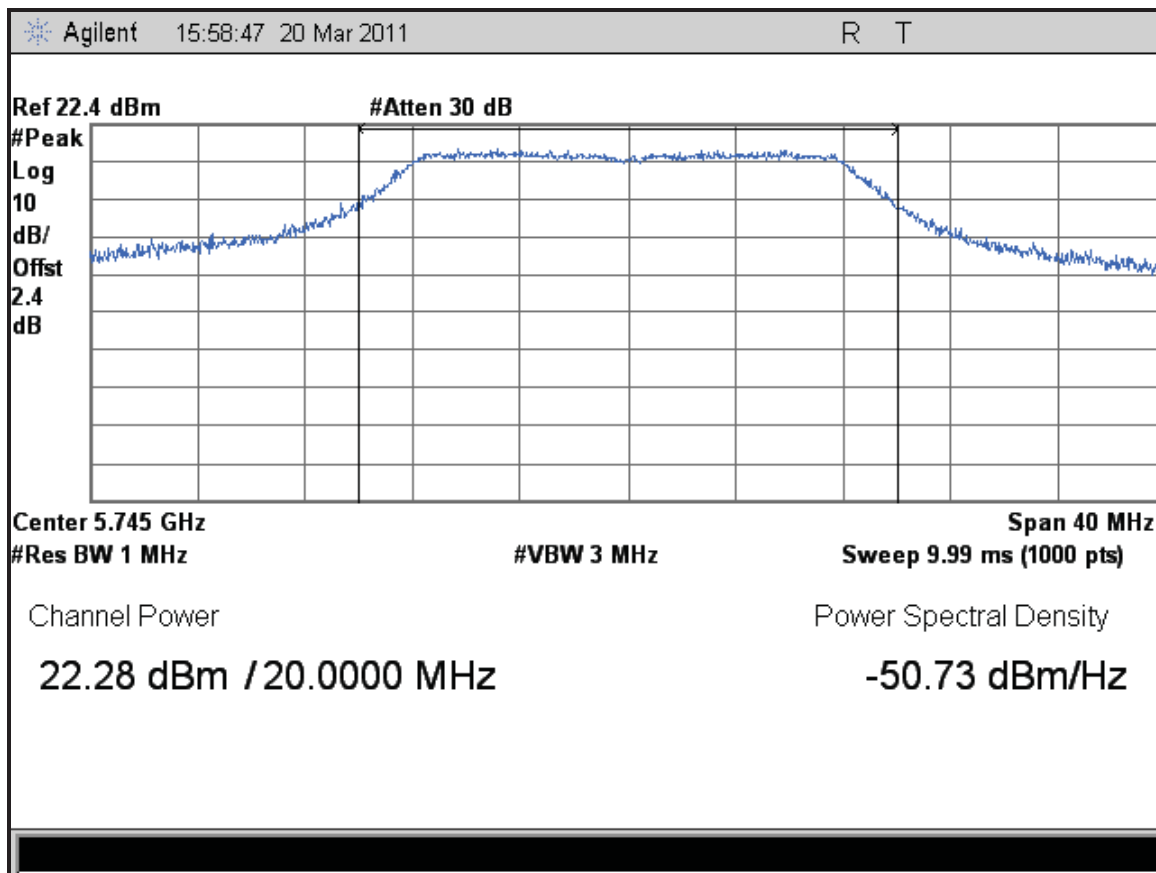

Figure 379: Maximum Transmitted Power, Lowest Channel 5745 MHz of 802.11a, Chain 2

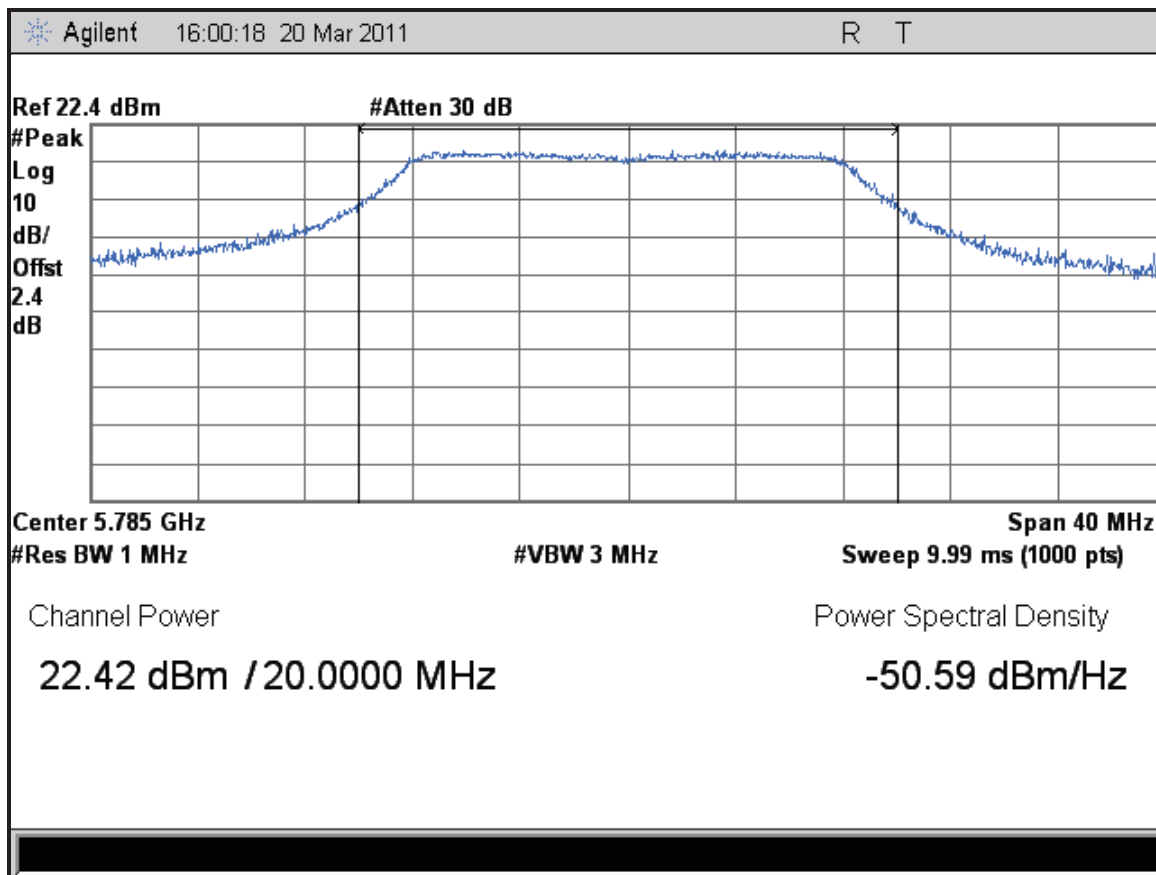

Figure 380: Maximum Transmitted Power, Middle Channel 5785 MHz of 802.11a, Chain 2

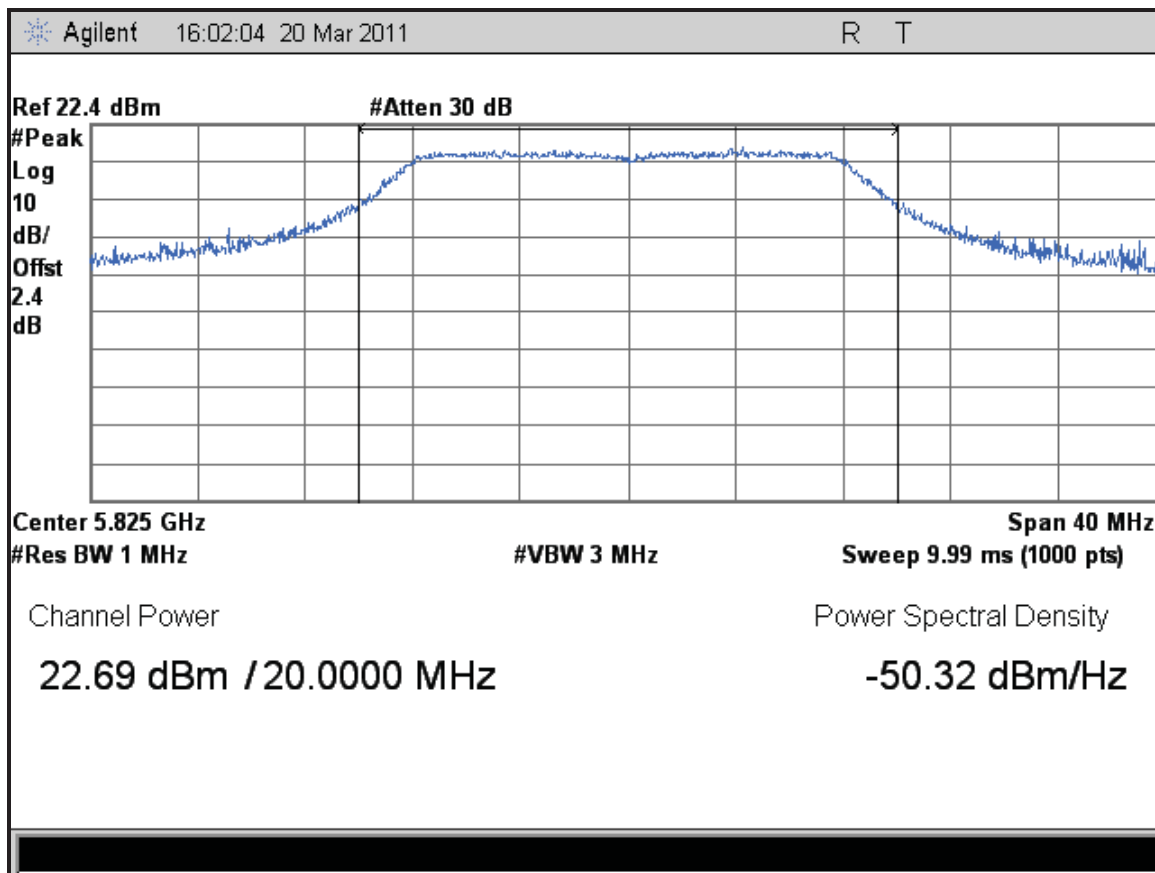

Figure 381: Maximum Transmitted Power, Highest Channel 5825 MHz of 802.11a, Chain 2

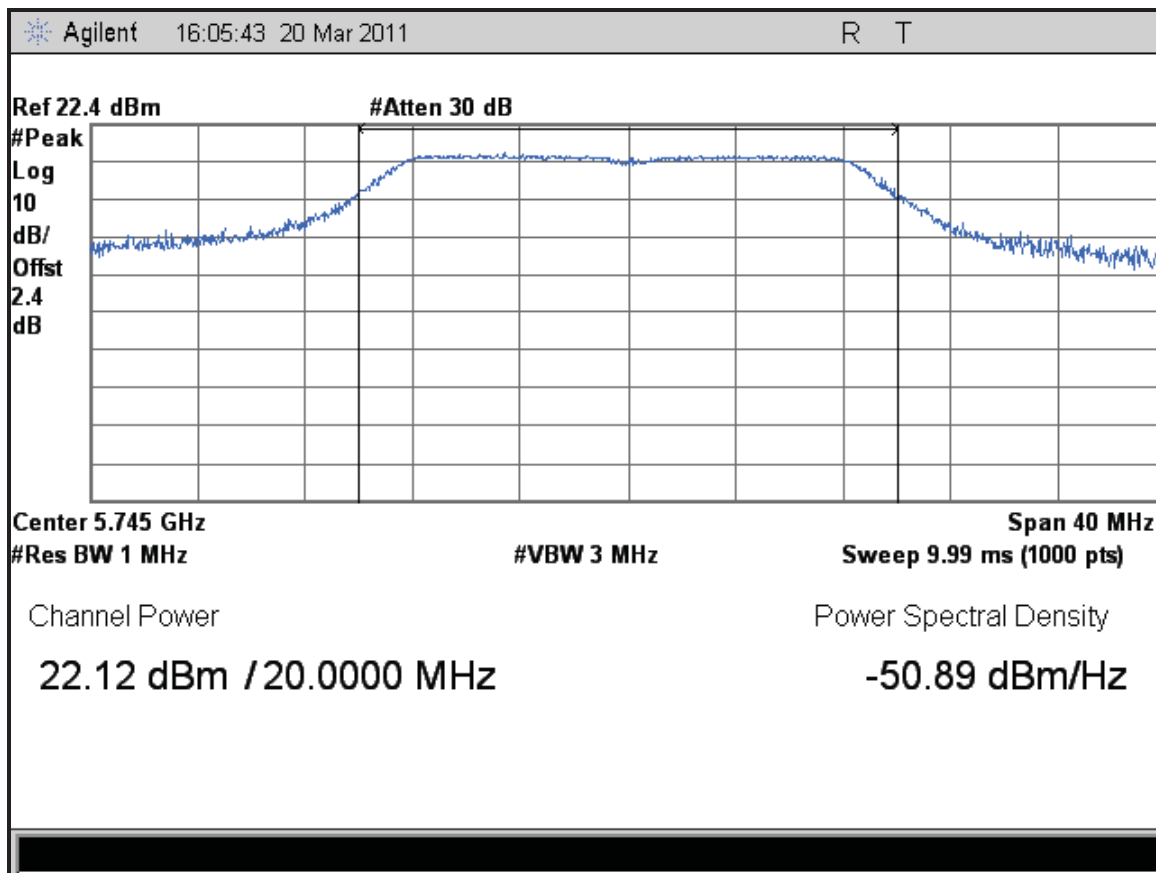

Figure 382: Maximum Transmitted Power, Lowest Channel 5745 MHz of 802.11n HT20, Chain 0 – 6.5 Mbps

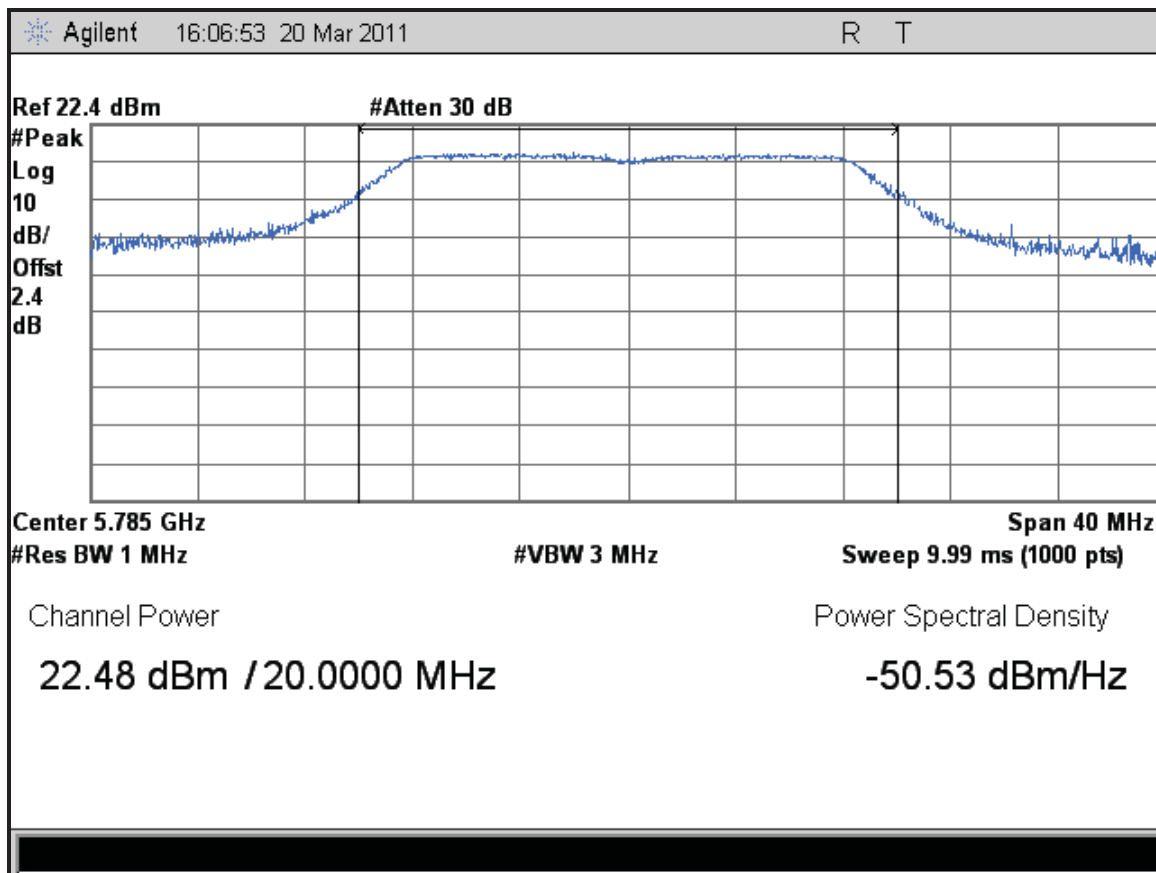

Figure 383: Maximum Transmitted Power, Middle Channel 5785 MHz of 802.11n HT20, Chain 0 – 6.5 Mbps

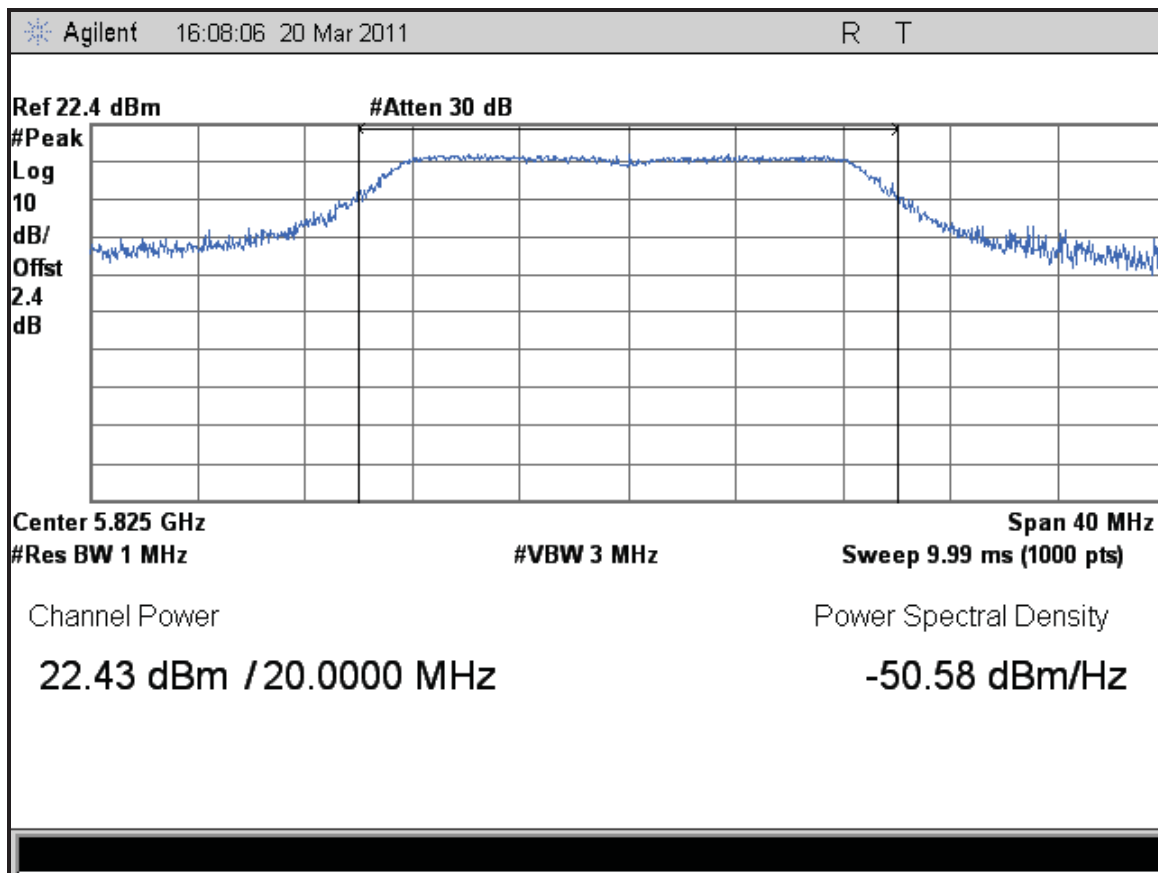

Figure 384: Maximum Transmitted Power, Highest Channel 5825 MHz of 802.11n HT20, Chain 0 – 6.5 Mbps

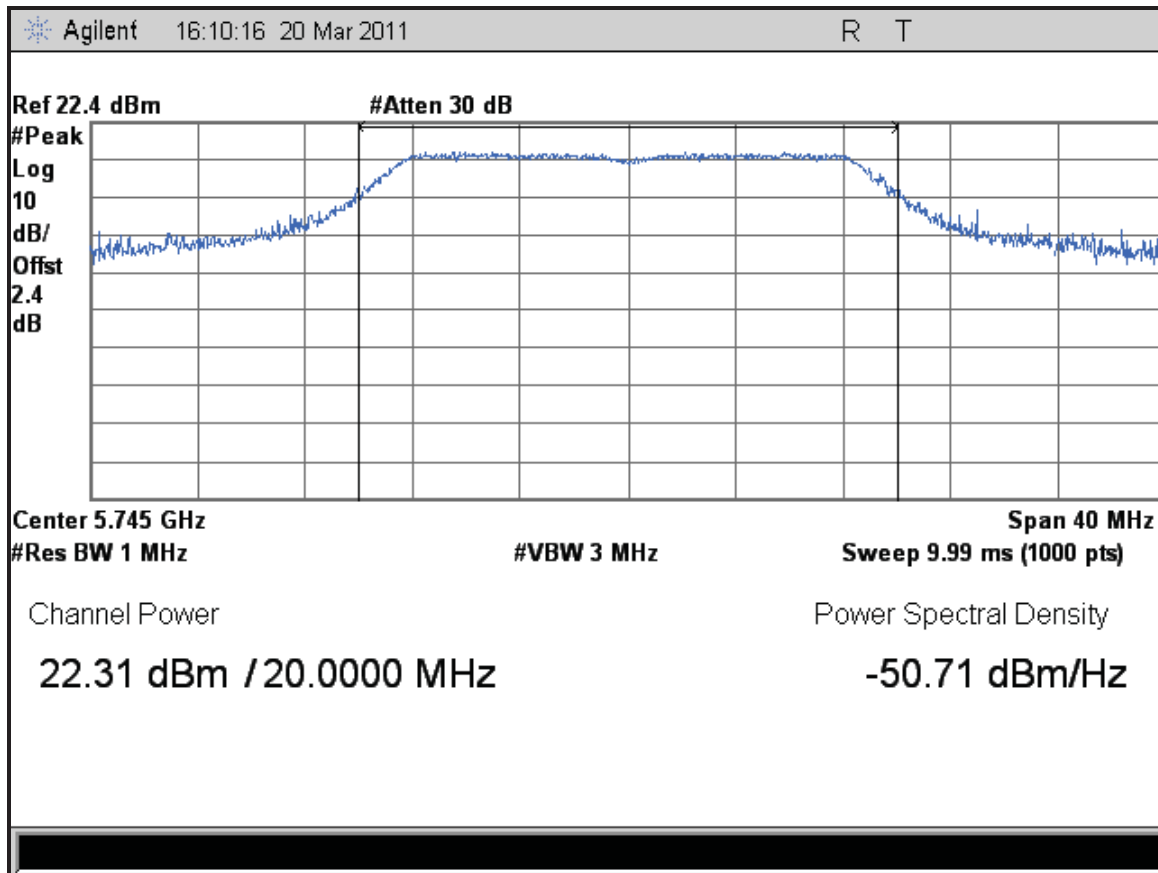

Figure 385: Maximum Transmitted Power, Lowest Channel 5745 MHz of 802.11n HT20, Chain 1 – 6.5 Mbps

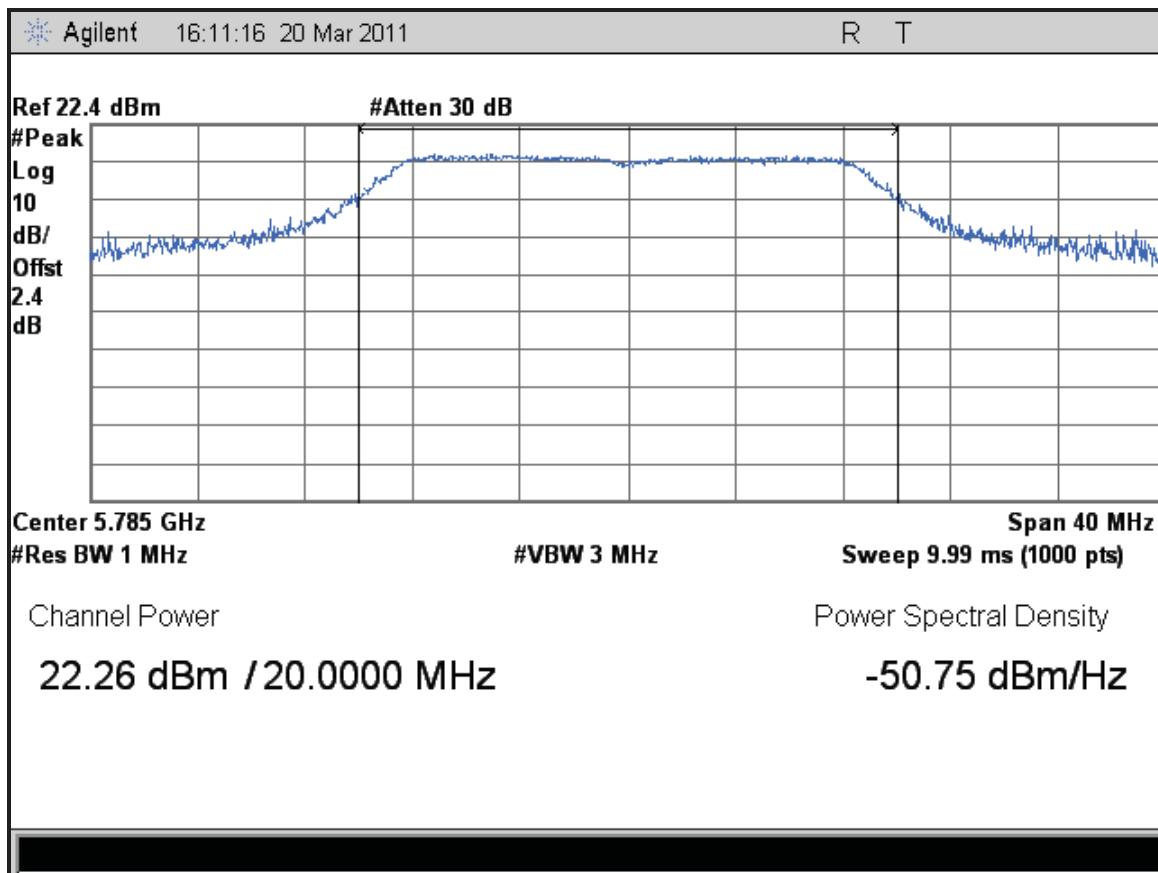

Figure 386: Maximum Transmitted Power, Middle Channel 5785 MHz of 802.11n HT20, Chain 1 – 6.5 Mbps

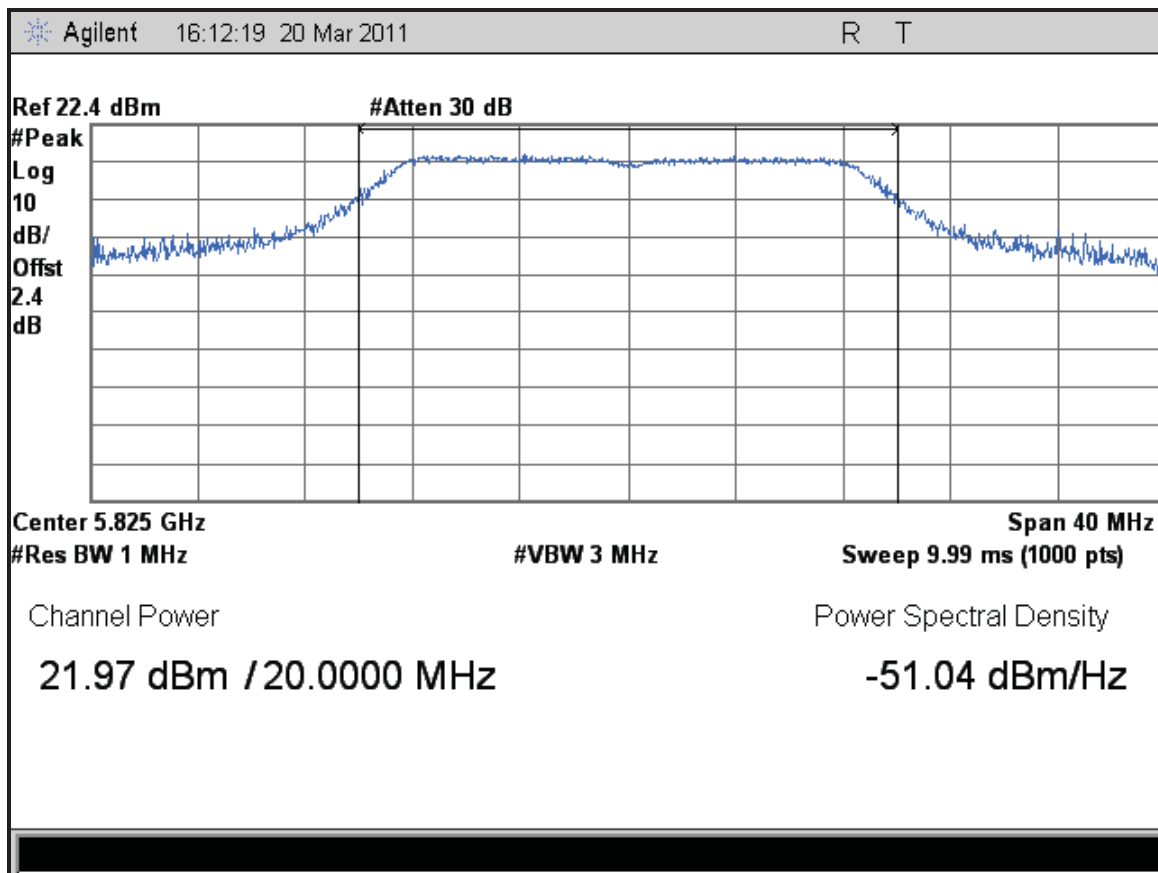

Figure 387: Maximum Transmitted Power, Highest Channel 5825 MHz of 802.11n HT20, Chain 1 – 6.5 Mbps

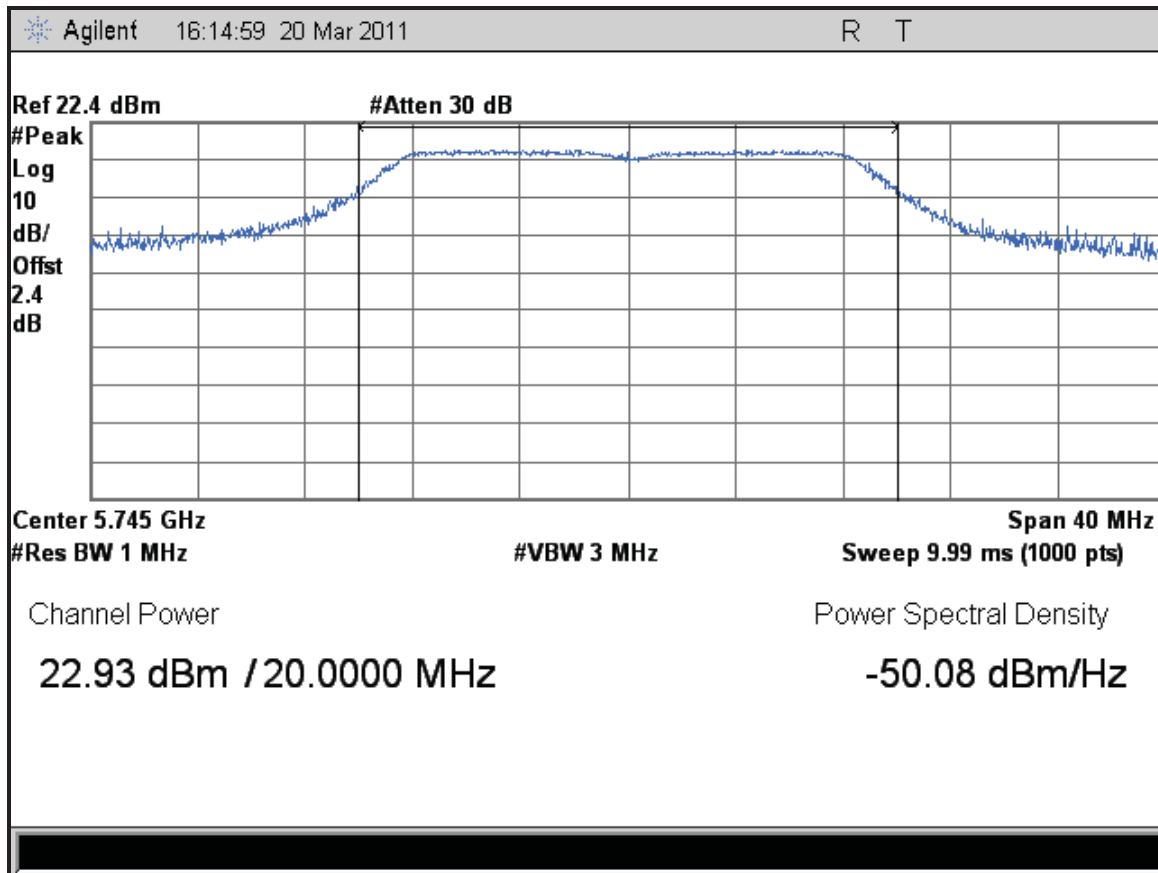

Figure 388: Maximum Transmitted Power, Lowest Channel 5745 MHz of 802.11n HT20, Chain 2 – 6.5 Mbps

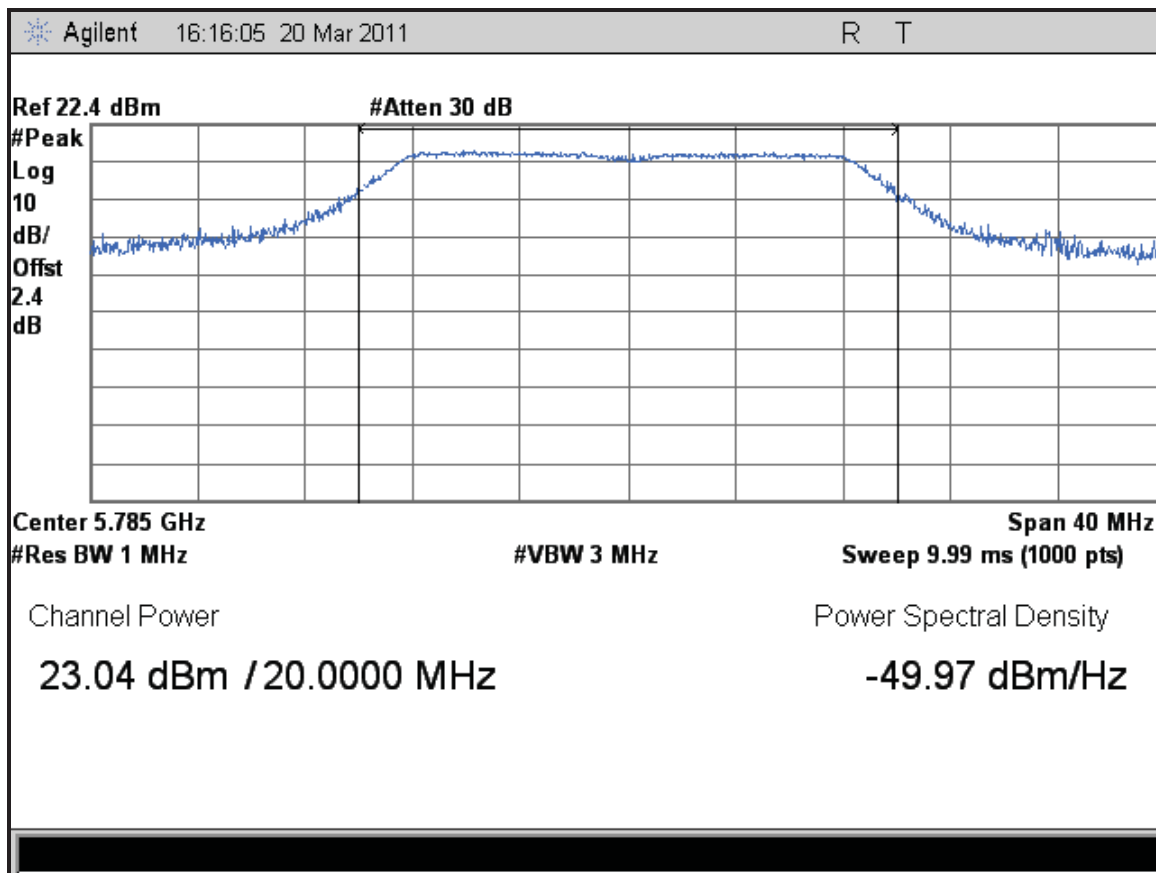

Figure 389: Maximum Transmitted Power, Middle Channel 5785 MHz of 802.11n HT20, Chain 2 – 6.5 Mbps

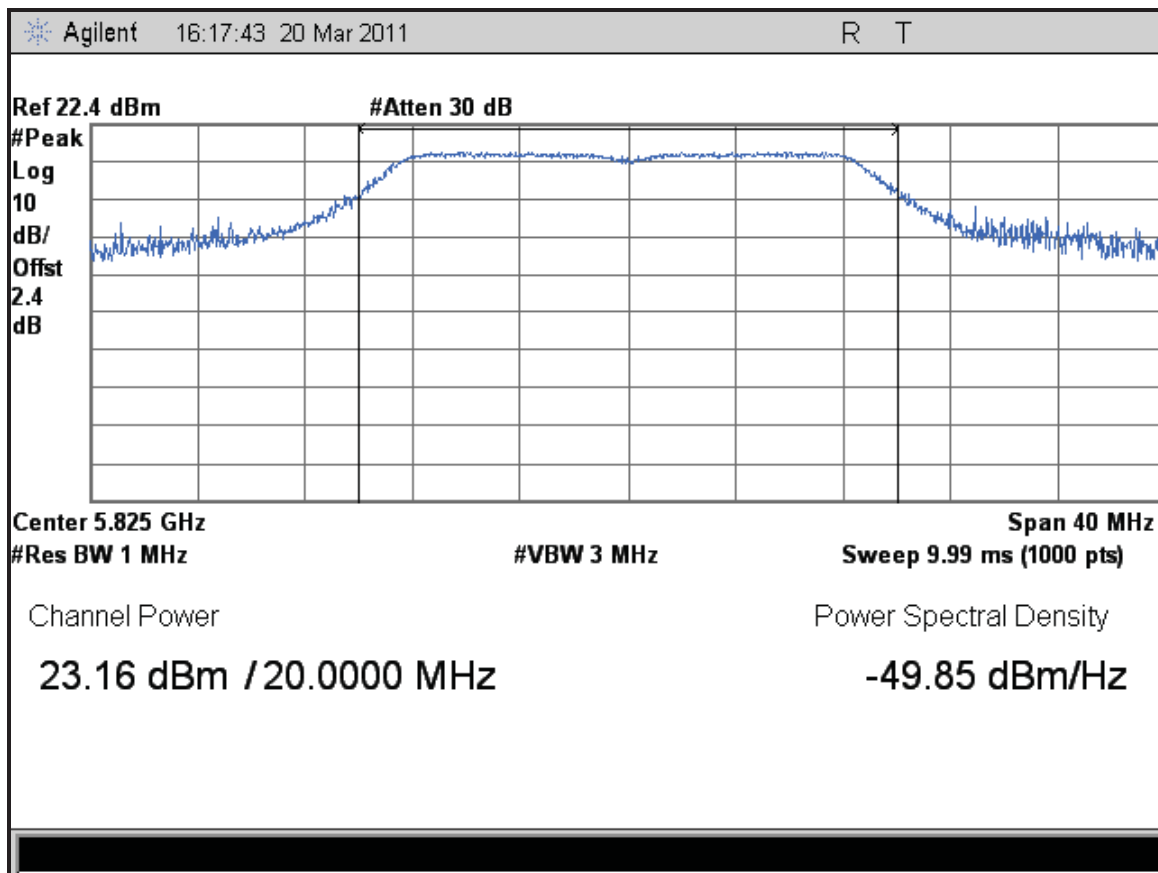

Figure 390: Maximum Transmitted Power, Highest Channel 5825 MHz of 802.11n HT20, Chain 2 – 6.5 Mbps

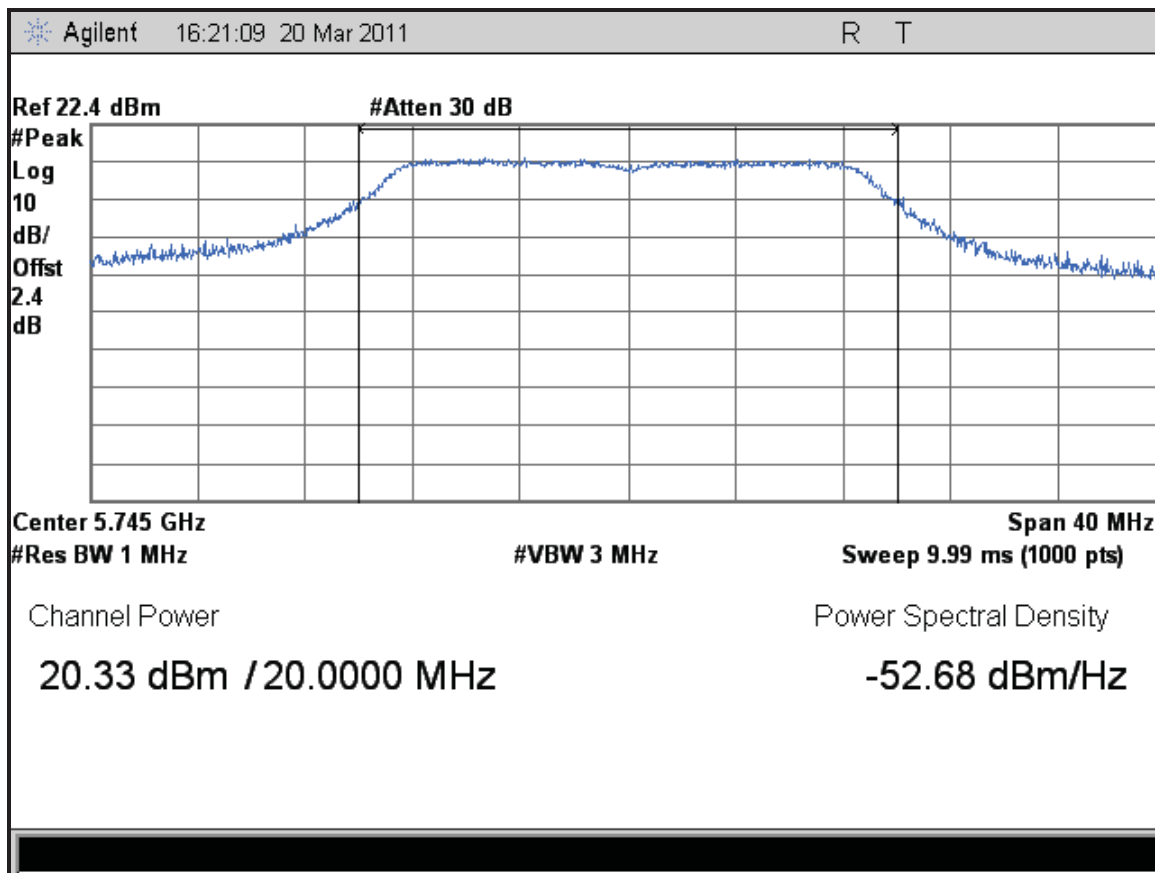

Figure 391: Maximum Transmitted Power, Lowest Channel 5745 MHz of 802.11n HT20, 2 Data Stream, Chain 0

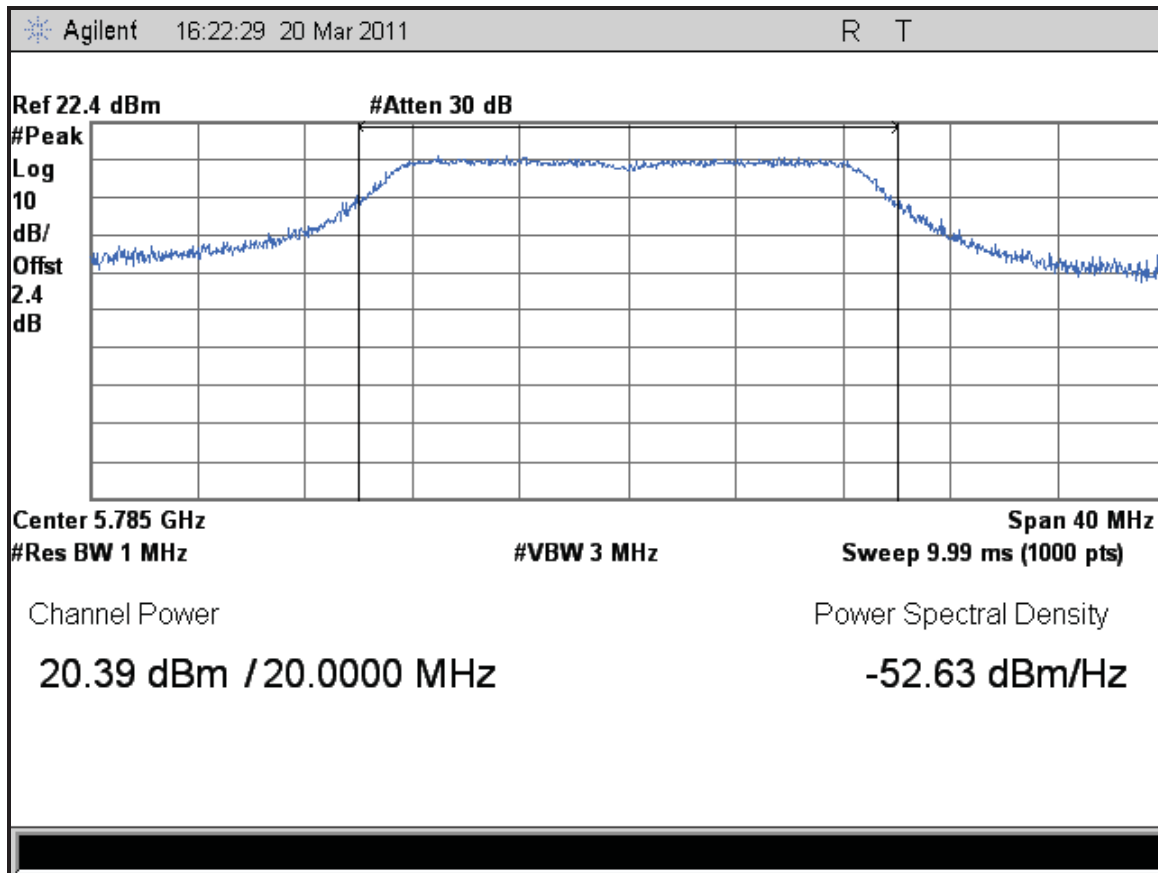

Figure 392: Maximum Transmitted Power, Middle Channel 5785 MHz of 802.11n HT20, 2 Data Stream, Chain 0

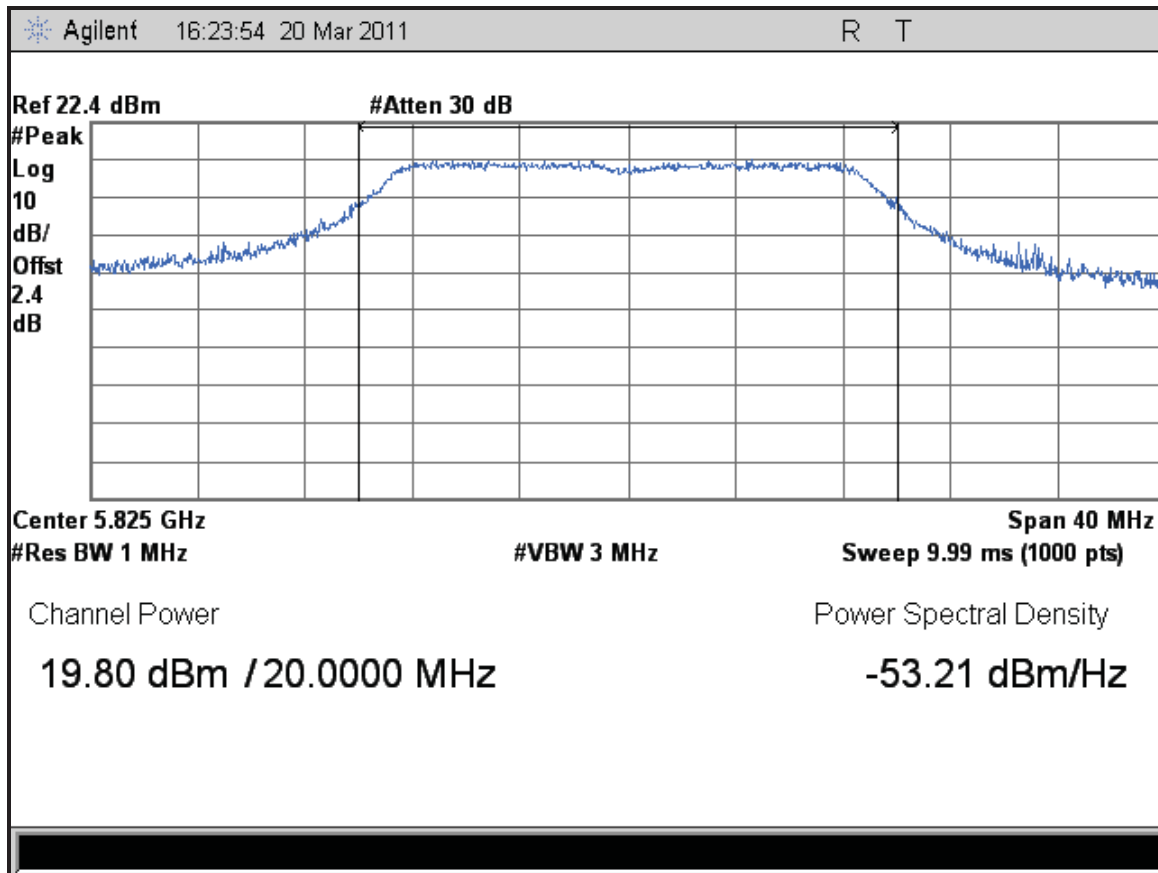

Figure 393: Maximum Transmitted Power, Highest Channel 5825 MHz of 802.11n HT20, 2 Data Stream, Chain 0

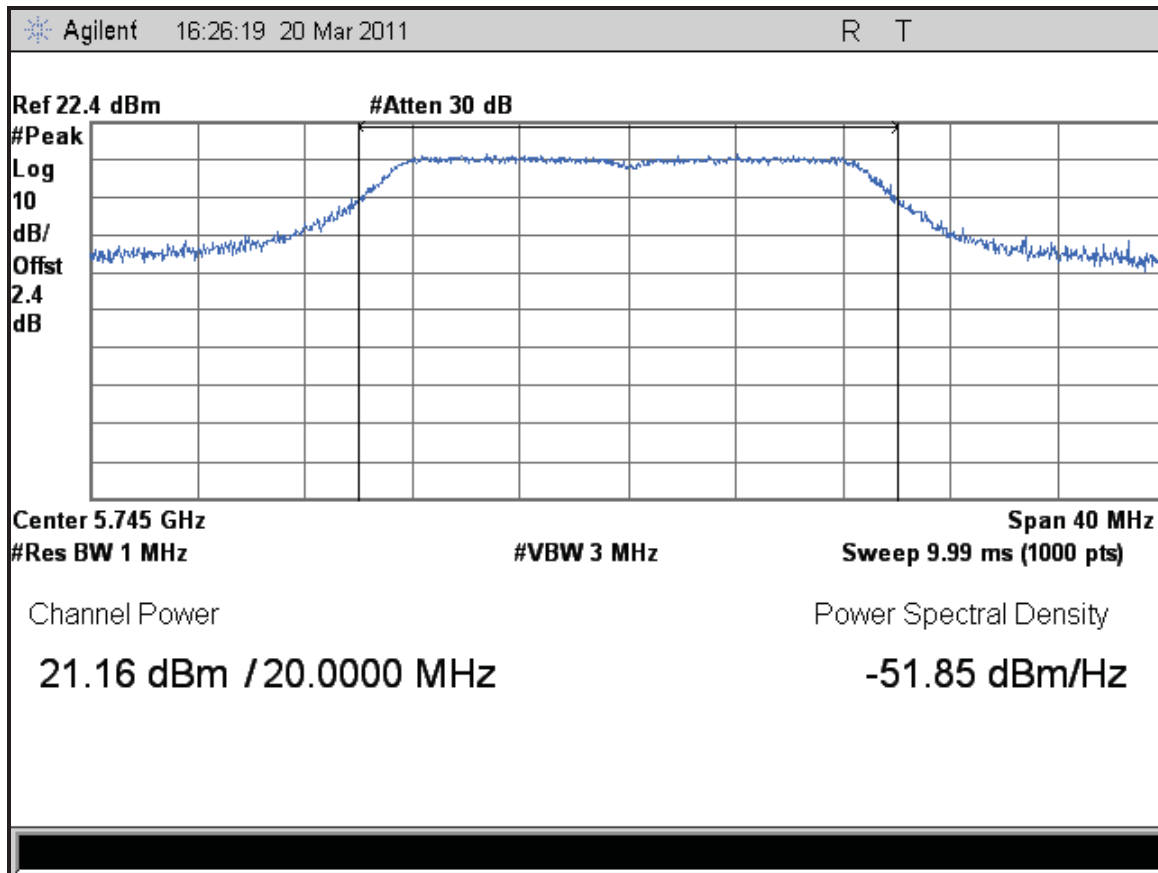

Figure 394: Maximum Transmitted Power, Lowest Channel 5745 MHz of 802.11n HT20, 2 Data Stream, Chain 1

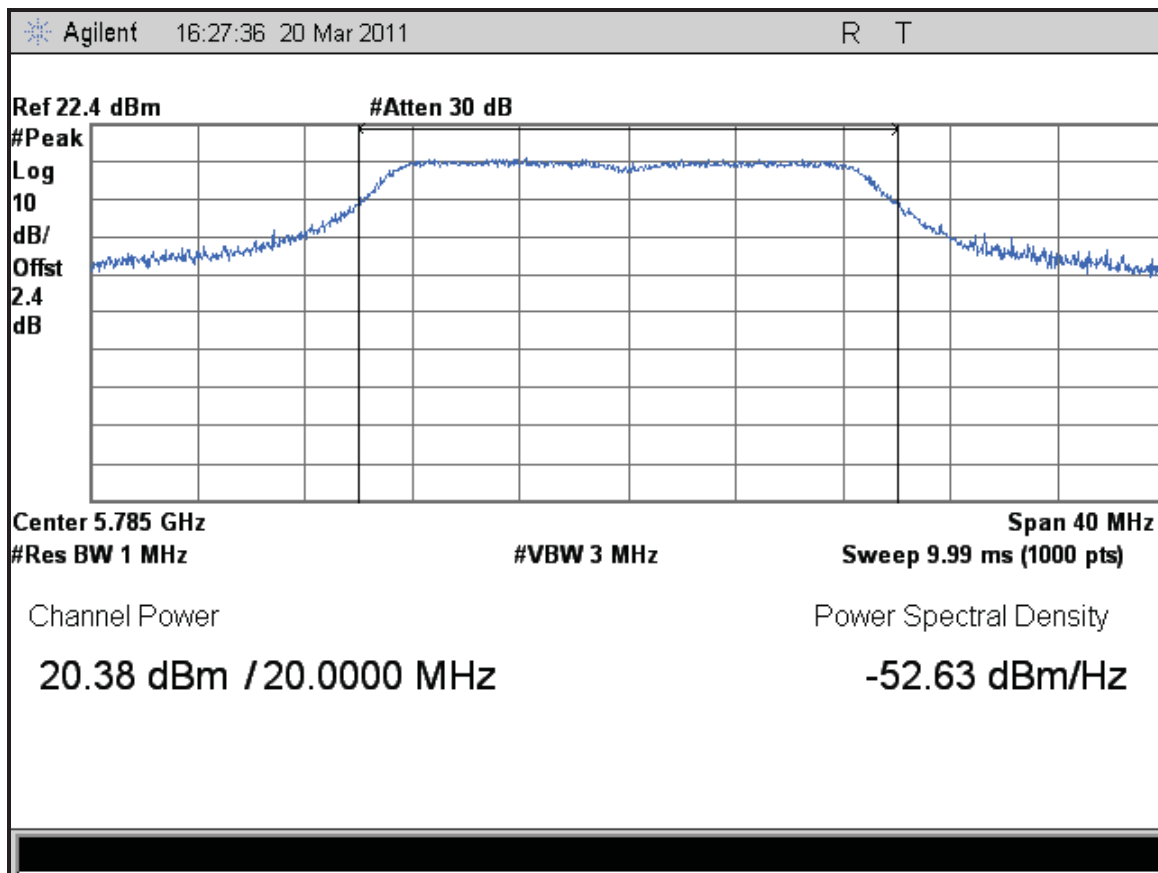

Figure 395: Maximum Transmitted Power, Middle Channel 5785 MHz of 802.11n HT20, 2 Data Stream, Chain 1

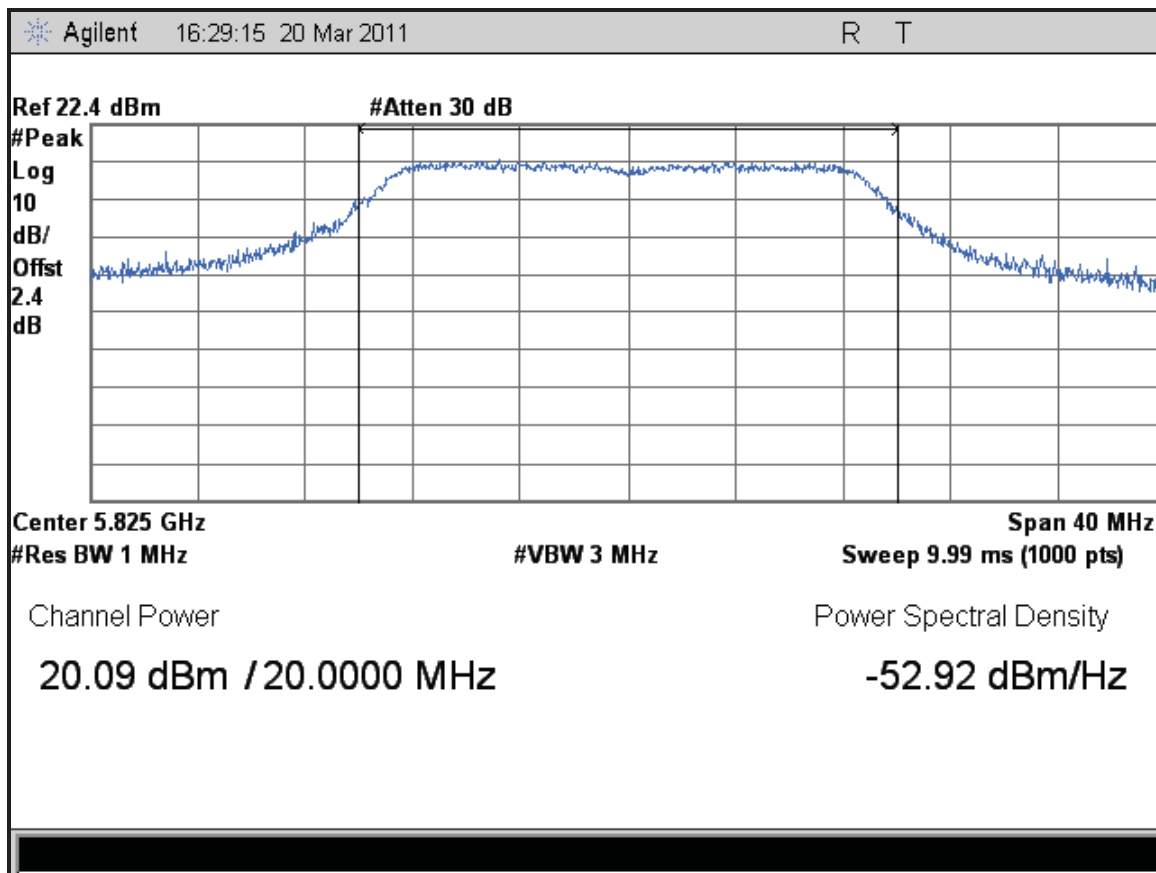

Figure 396: Maximum Transmitted Power, Highest Channel 5825 MHz of 802.11n HT20, 2 Data Stream, Chain 1

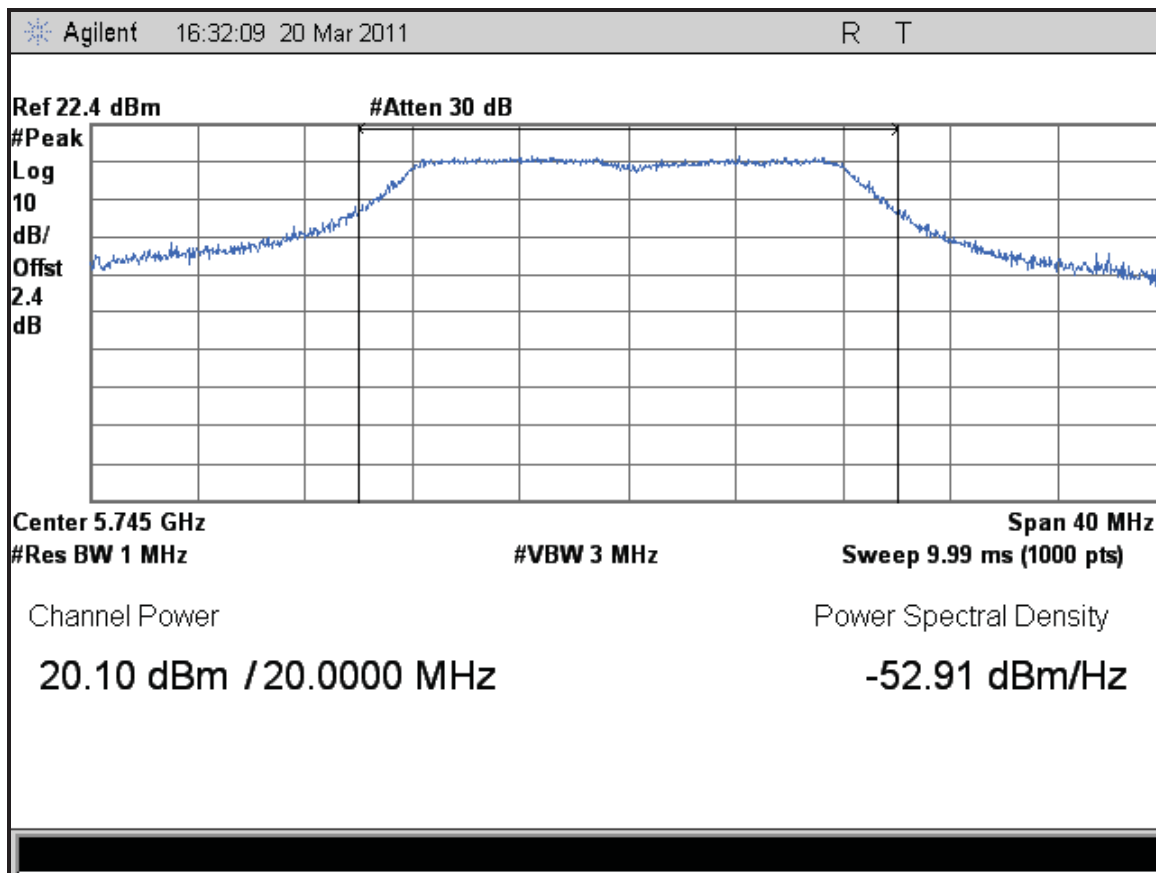

Figure 397: Maximum Transmitted Power, Lowest Channel 5745 MHz of 802.11n HT20, 3 Data Stream, Chain 0

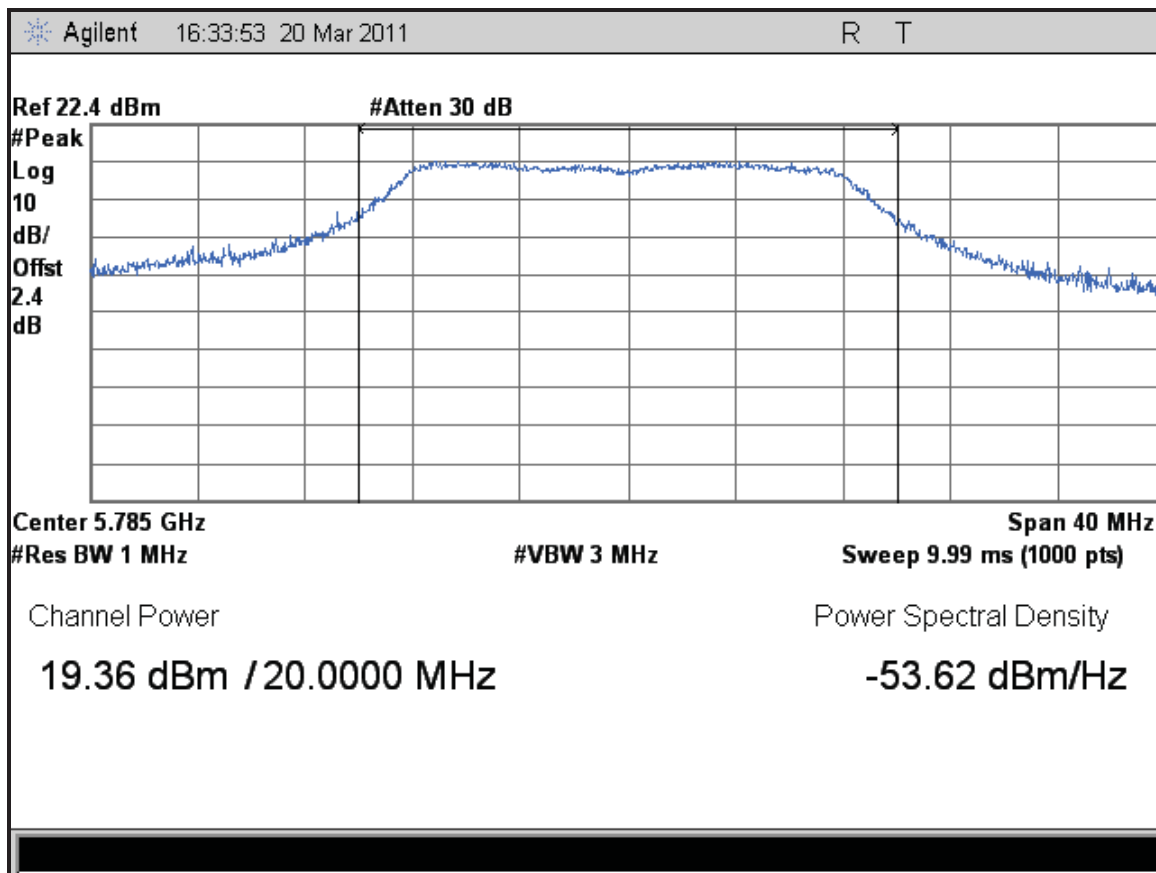

Figure 398: Maximum Transmitted Power, Middle Channel 5785 MHz of 802.11n HT20, 3 Data Stream, Chain 0

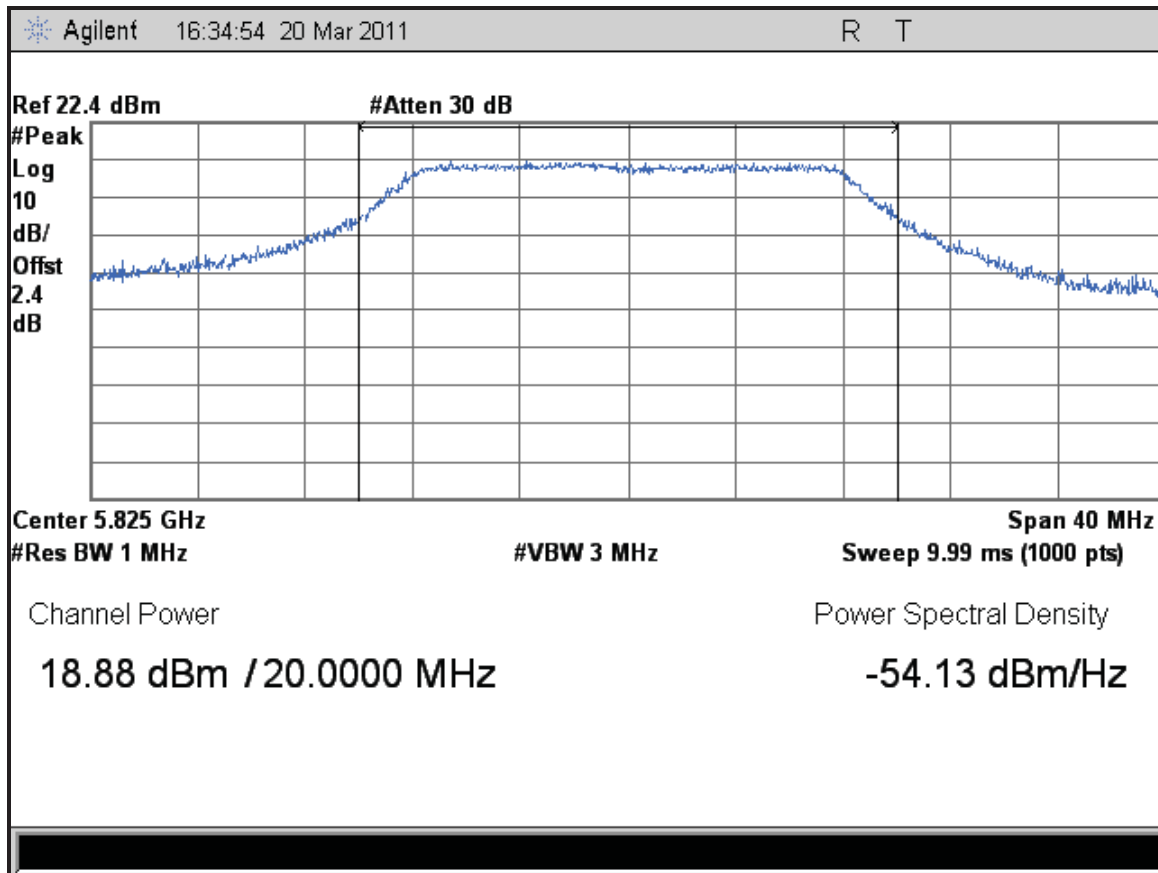

Figure 399: Maximum Transmitted Power, Highest Channel 5825 MHz of 802.11n HT20, 3 Data Stream, Chain 0

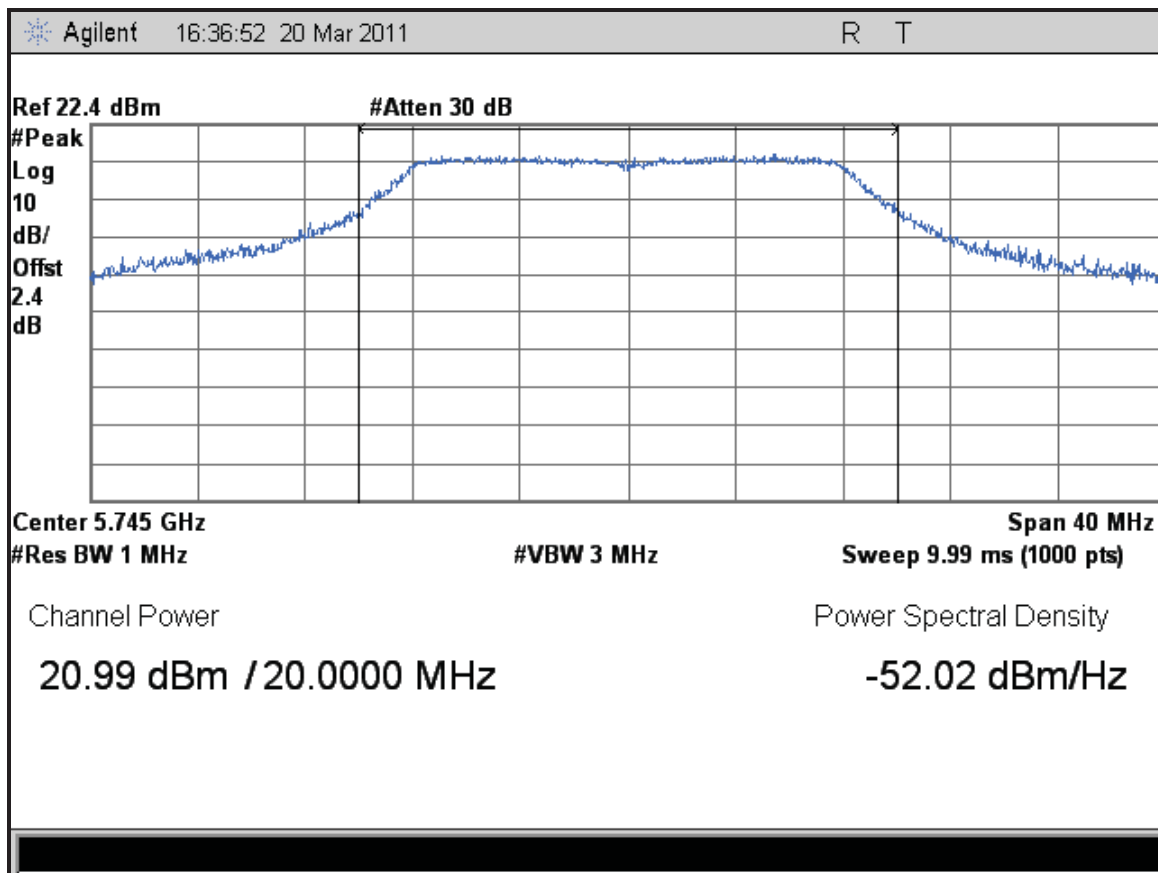

Figure 400: Maximum Transmitted Power, Lowest Channel 5745 MHz of 802.11n HT20, 3 Data Stream, Chain 1

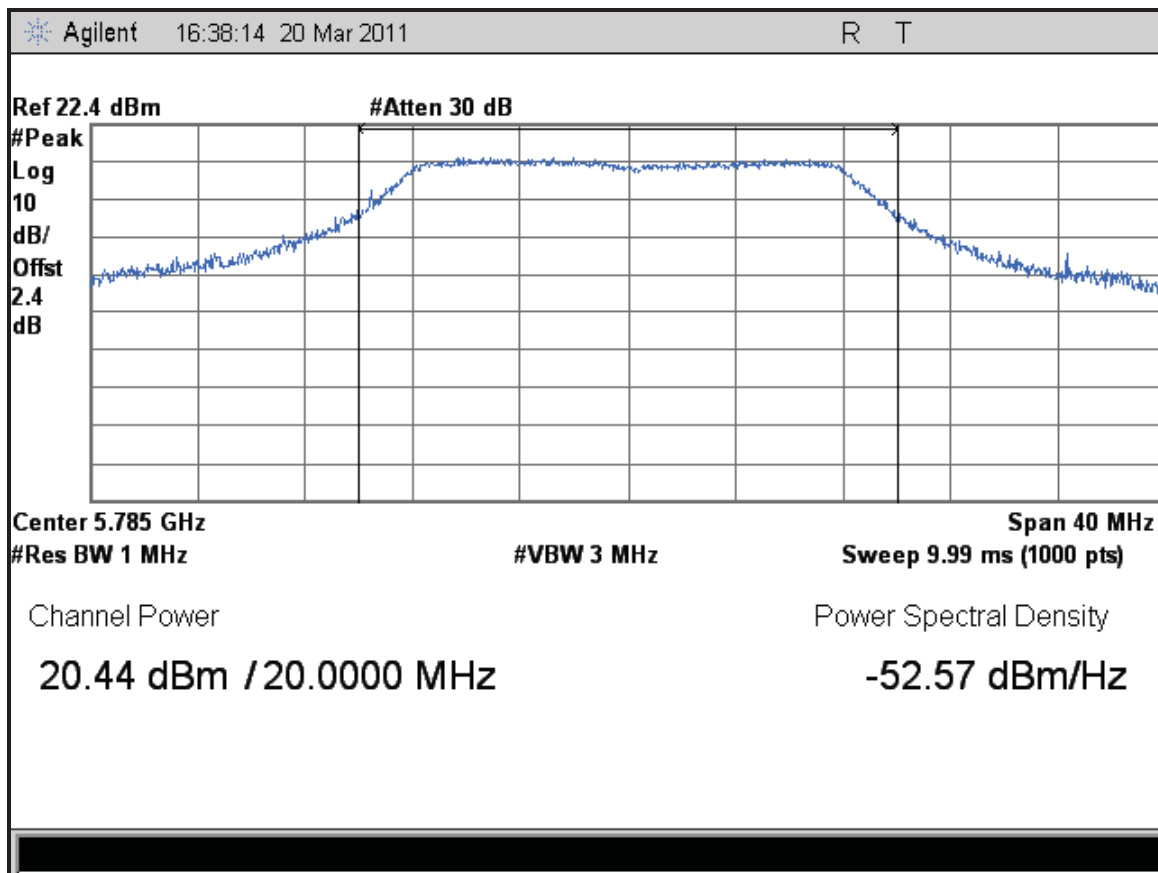

Figure 401: Maximum Transmitted Power, Middle Channel 5785 MHz of 802.11n HT20, 3 Data Stream, Chain 1

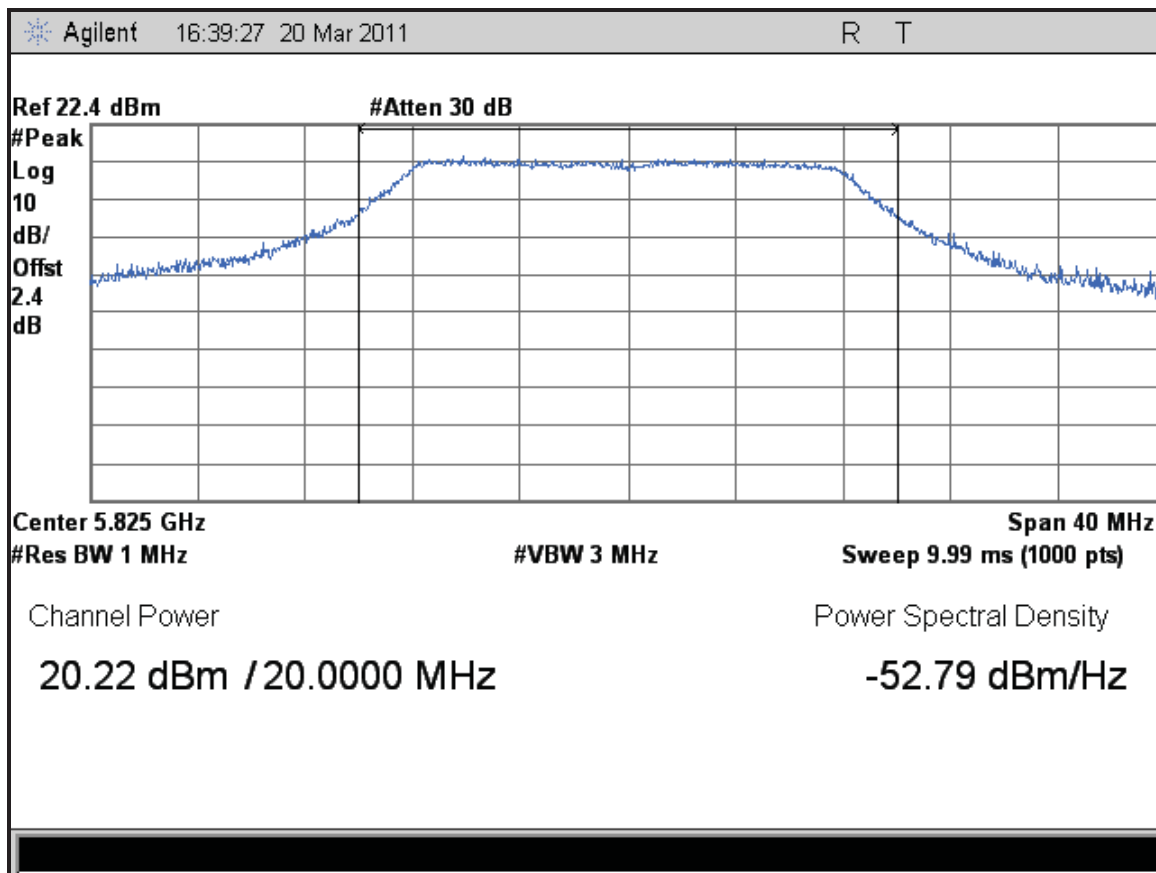

Figure 402: Maximum Transmitted Power, Highest Channel 5825 MHz of 802.11n HT20, 3 Data Stream, Chain 1

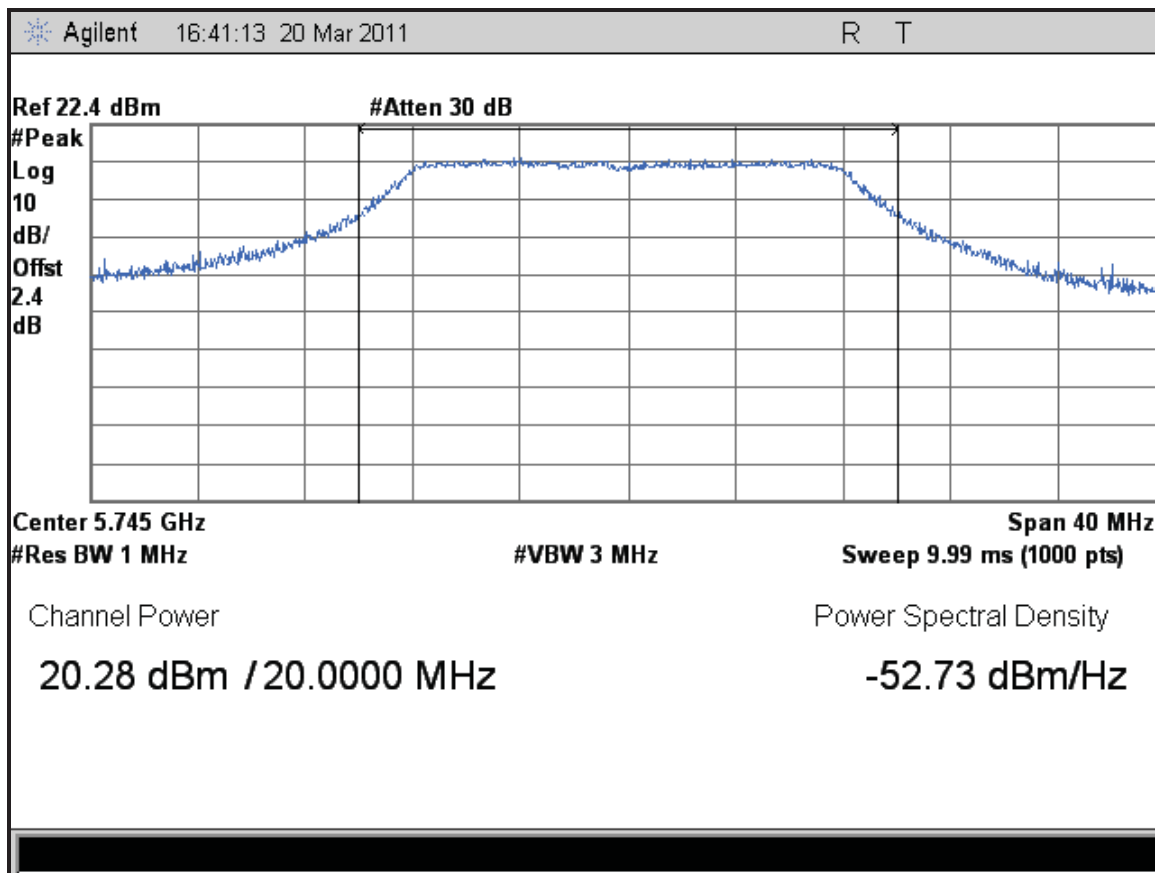

Figure 403: Maximum Transmitted Power, Lowest Channel 5745 MHz of 802.11n HT20, 3 Data Stream, Chain 2

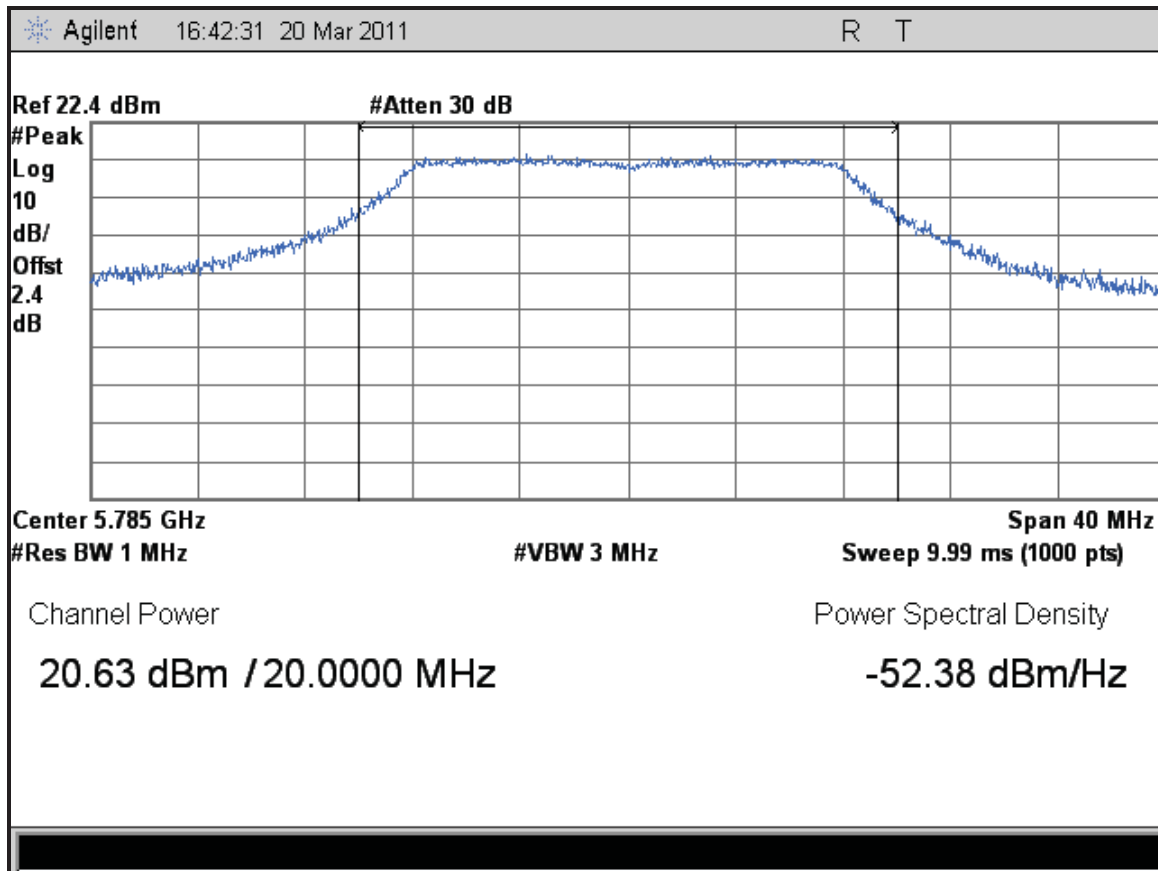

Figure 404: Maximum Transmitted Power, Middle Channel 5785 MHz of 802.11n HT20, 3 Data Stream, Chain 2

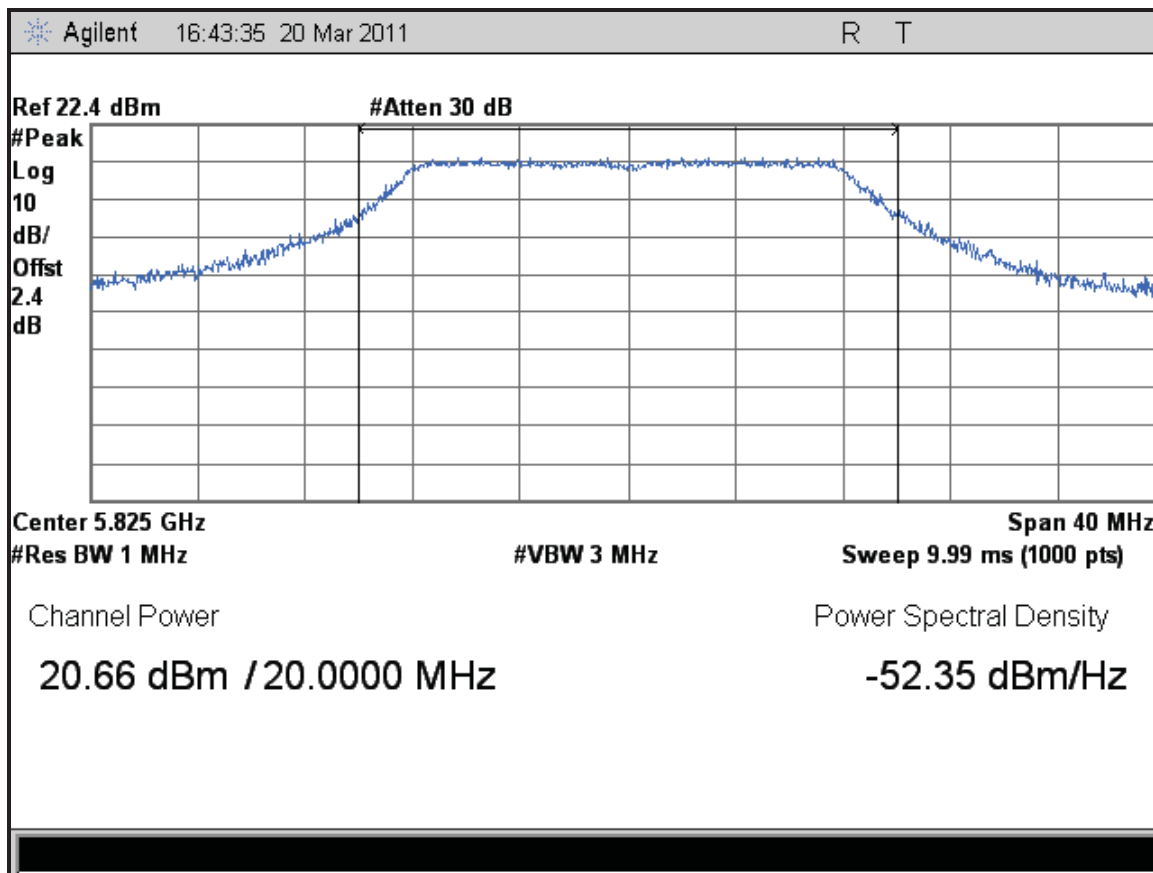

Figure 405: Maximum Transmitted Power, Highest Channel 5825 MHz of 802.11n HT20, 3 Data Stream, Chain 2

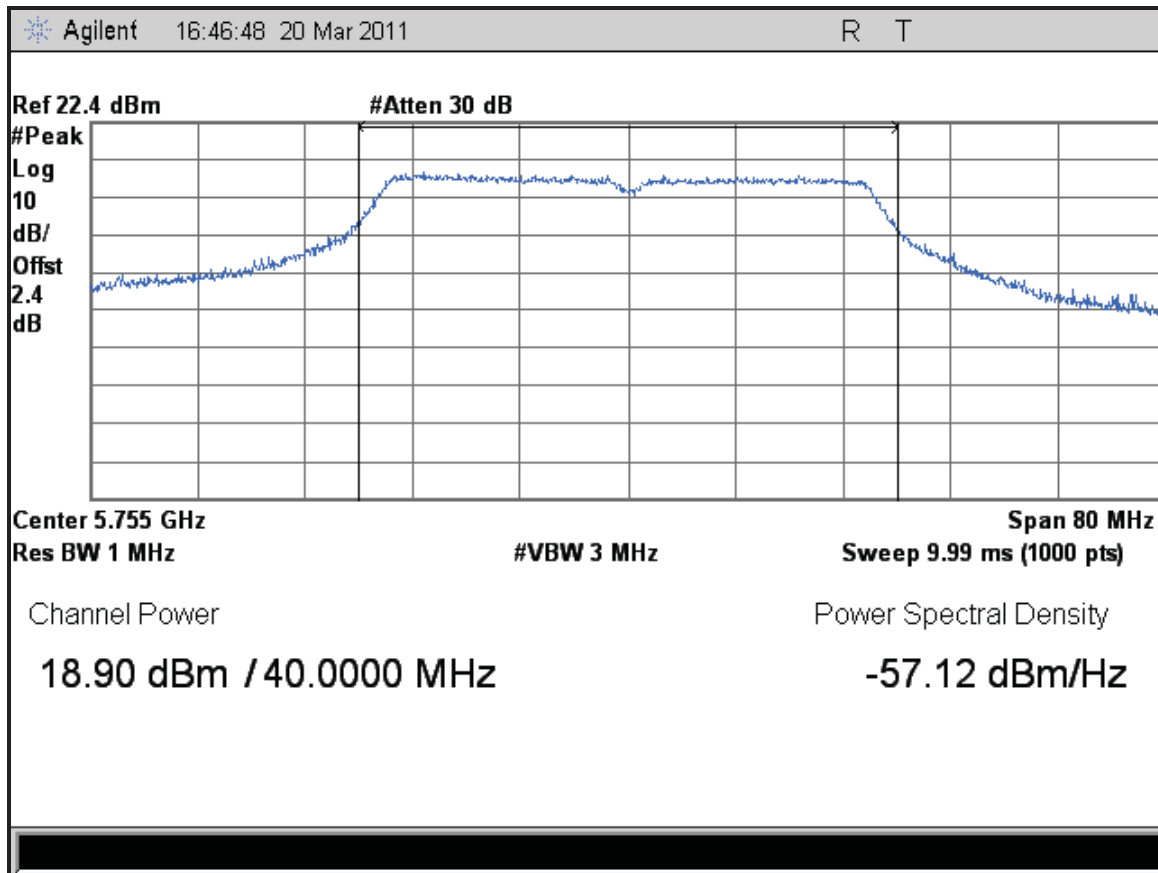

Figure 406: Maximum Transmitted Power, Lowest Channel 5755 MHz of 802.11n HT40, Chain 0 – 81 Mbps

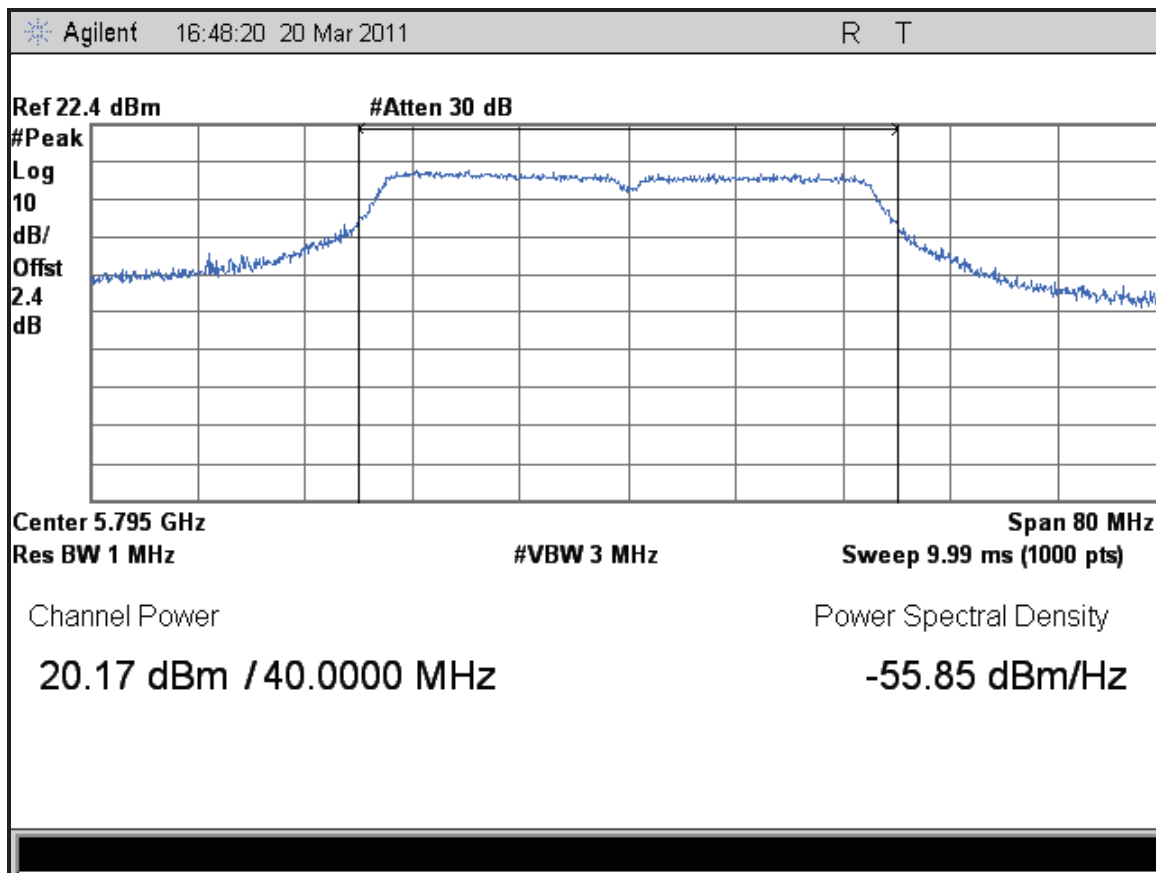

Figure 407: Maximum Transmitted Power, Middle Channel 5795 MHz of 802.11n HT40, Chain 0 – 81 Mbps

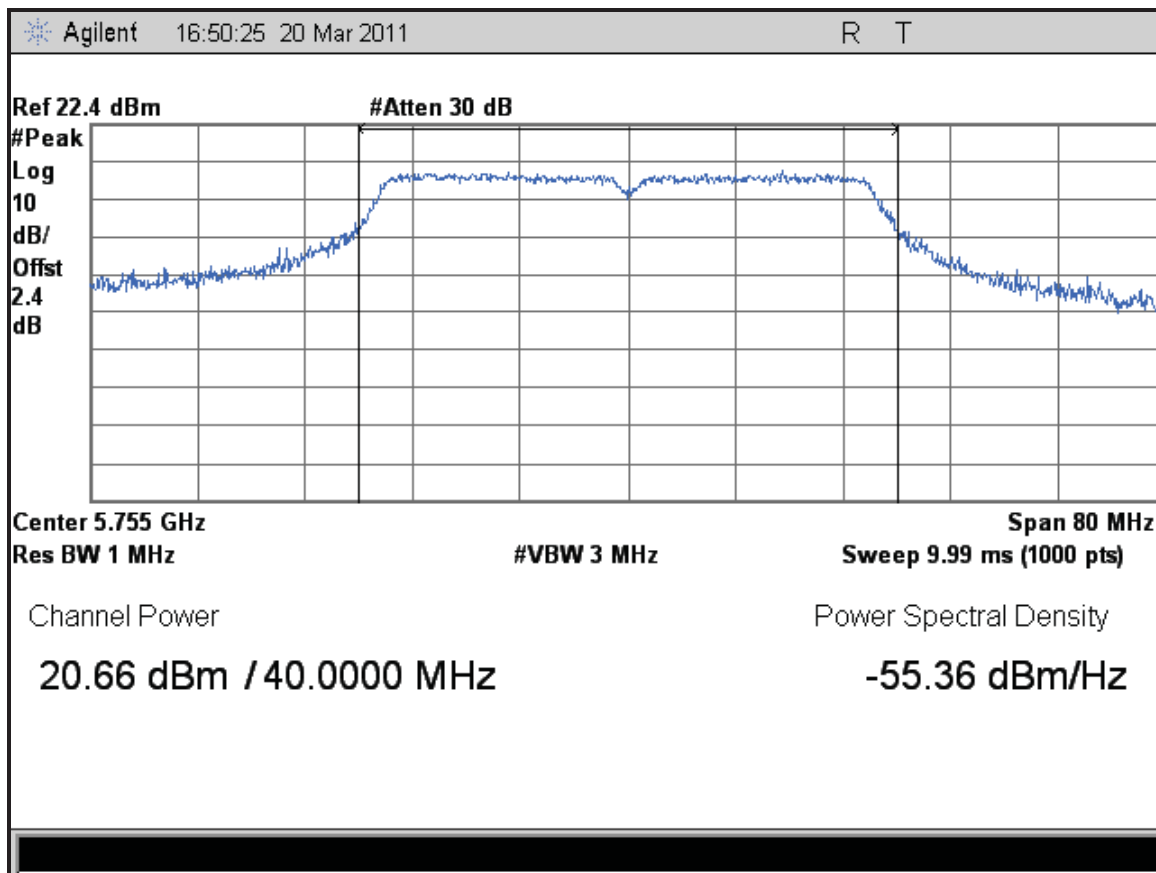

Figure 408: Maximum Transmitted Power, Lowest Channel 5755 MHz of 802.11n HT40, Chain 1 – 81 Mbps

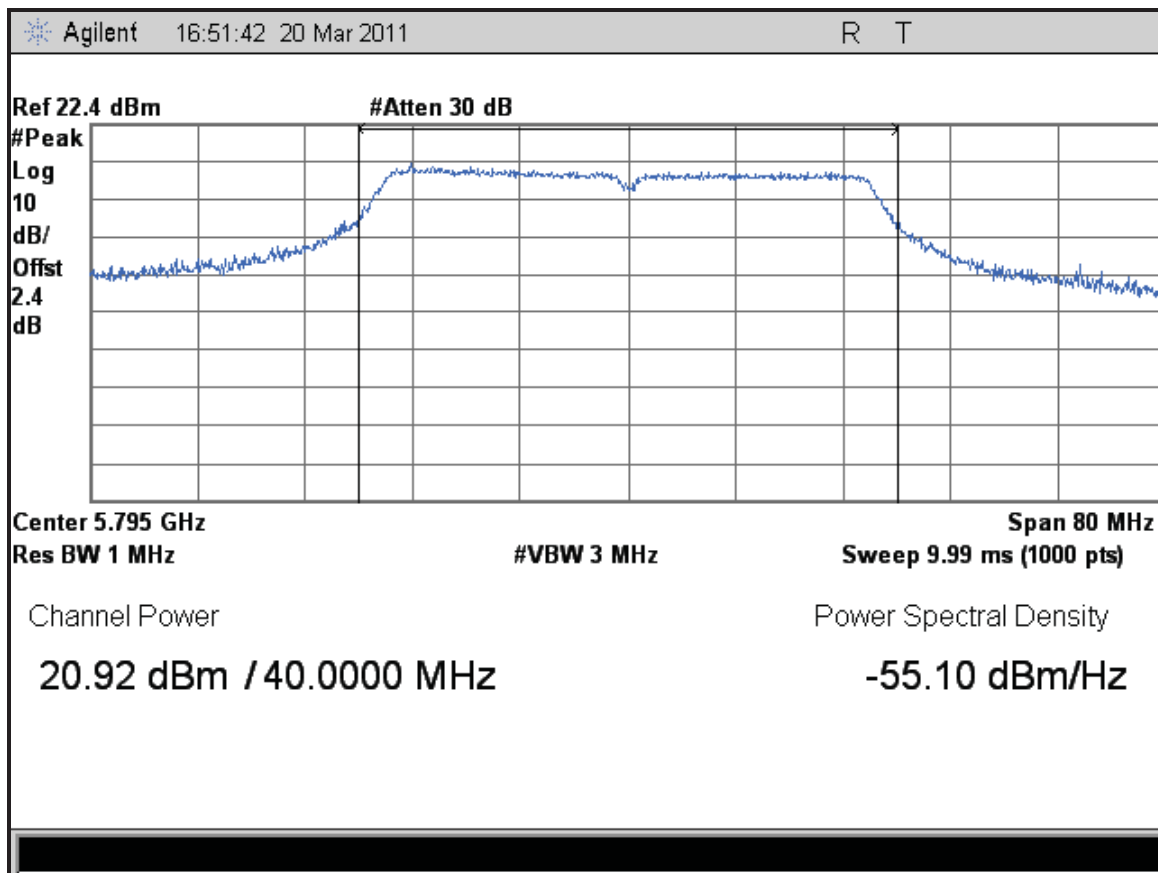

Figure 409: Maximum Transmitted Power, Middle Channel 5795 MHz of 802.11n HT40, Chain 1 – 81 Mbps

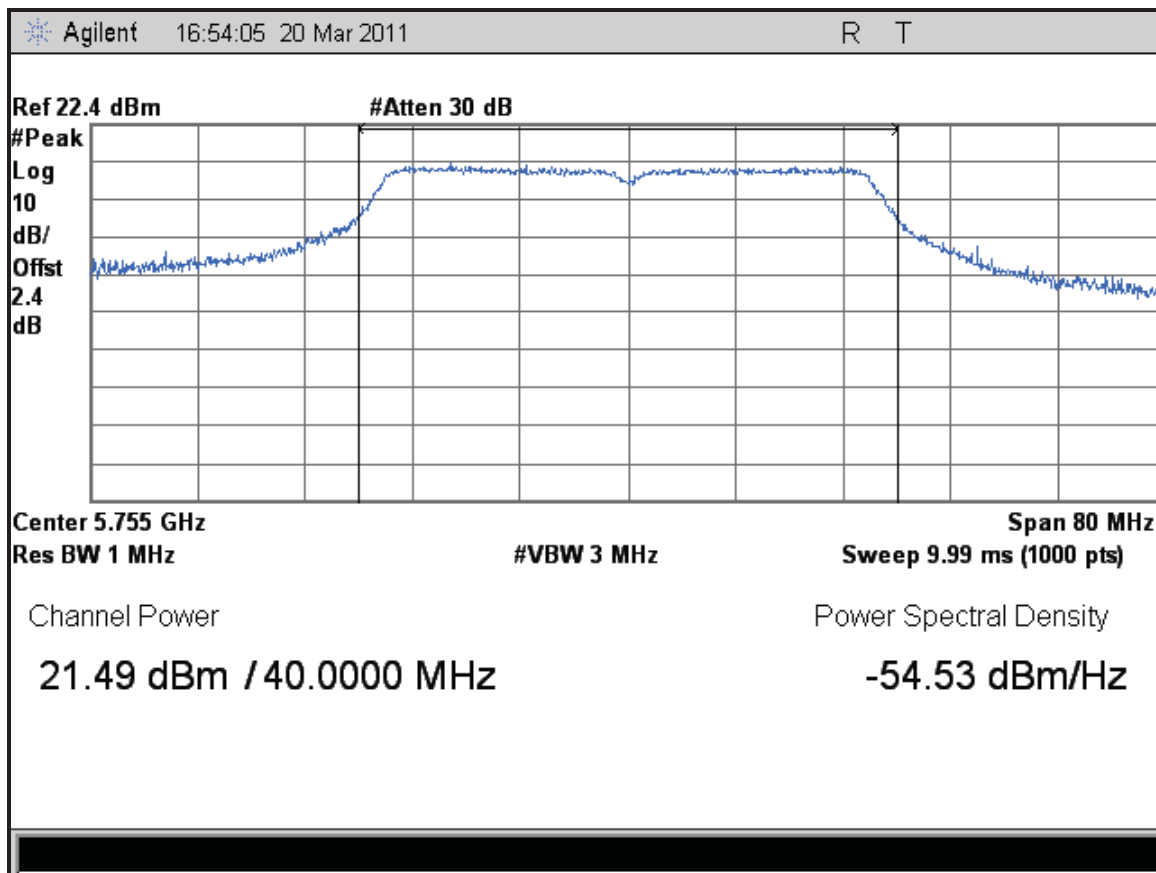

Figure 410: Maximum Transmitted Power, Lowest Channel 5755 MHz of 802.11n HT40, Chain 2 – 81 Mbps

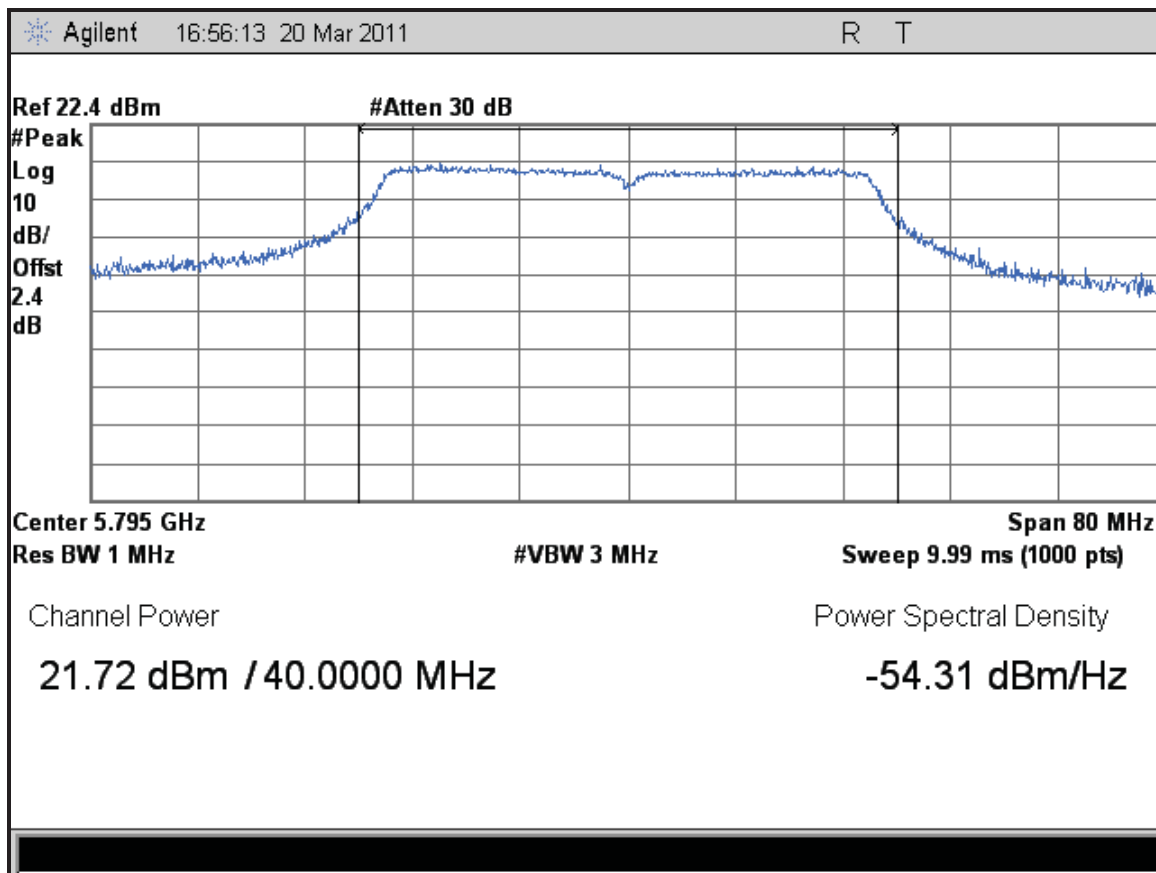

Figure 411: Maximum Transmitted Power, Middle Channel 5795 MHz of 802.11n HT40, Chain 2 – 81 Mbps

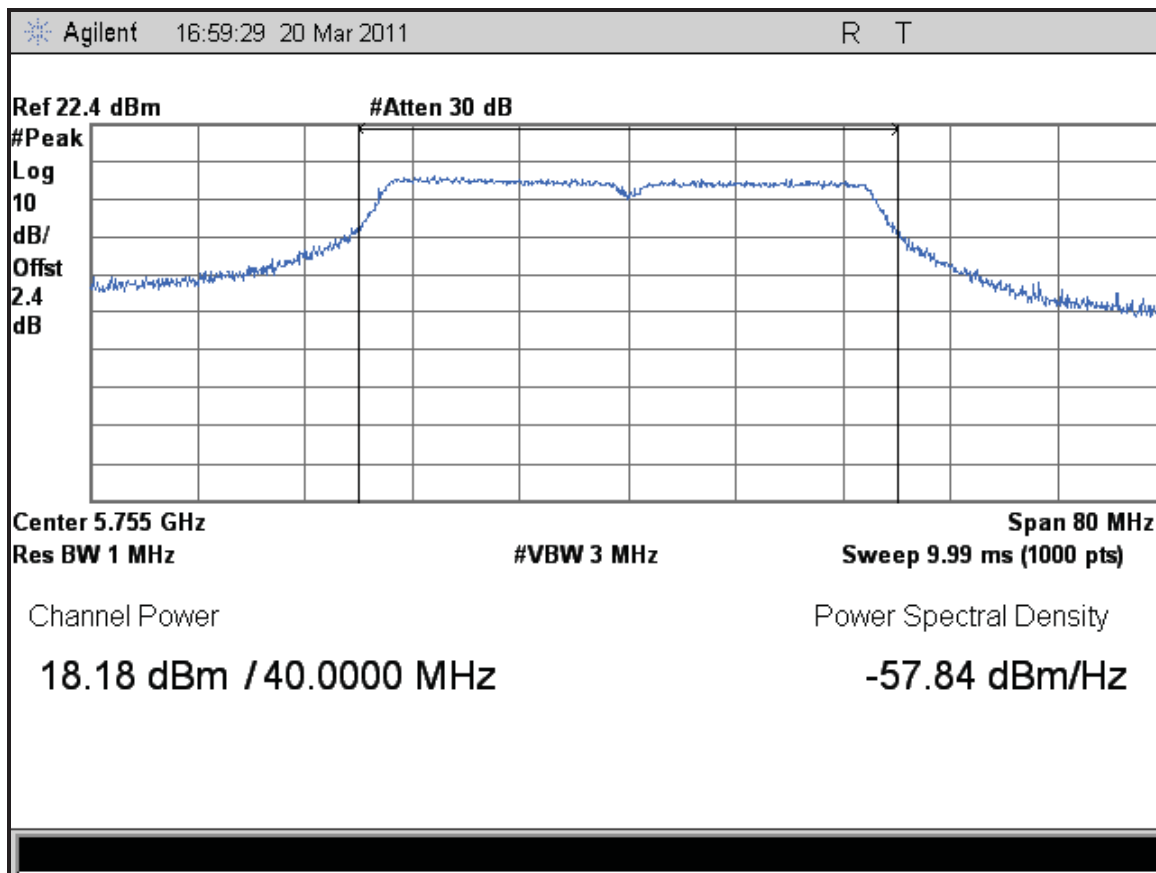

Figure 412: Maximum Transmitted Power, Lowest Channel 5755 MHz of 802.11n HT40, 2 Data Stream, Chain 0 – 27 Mbps

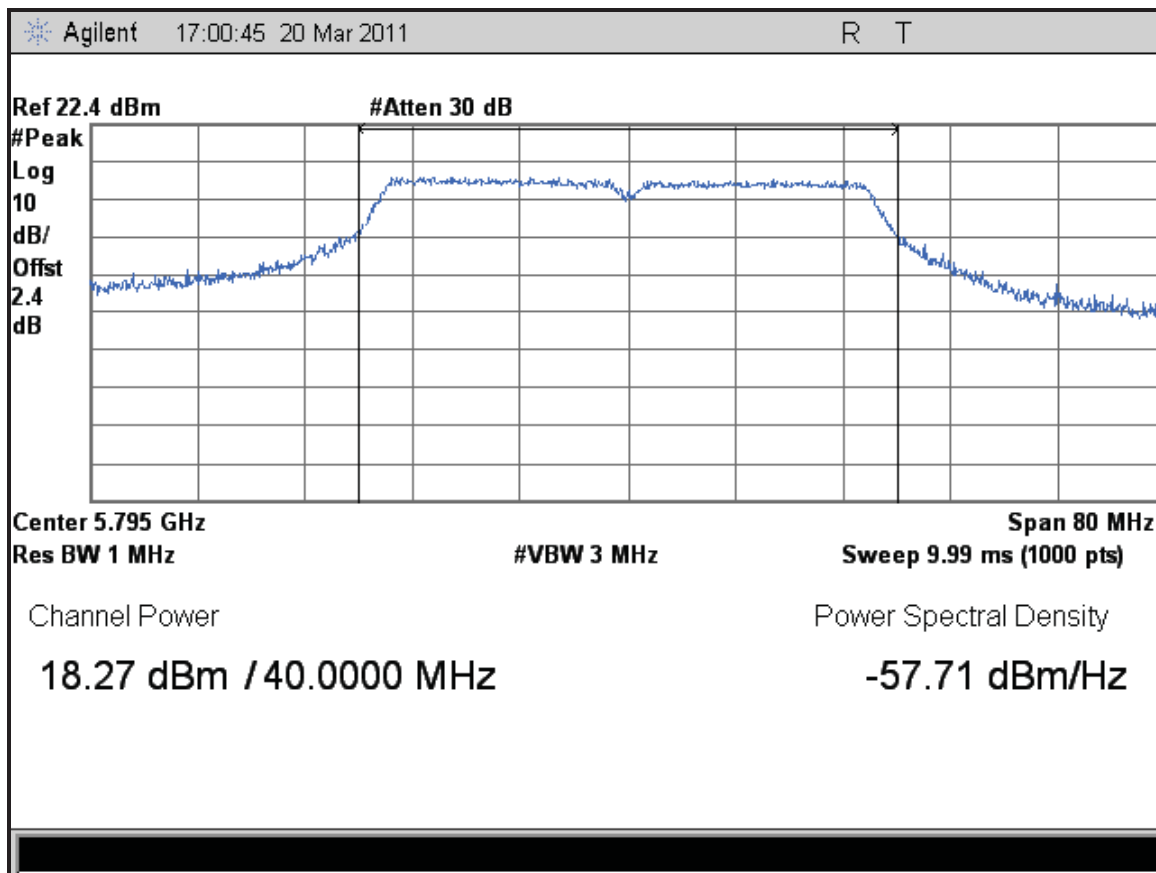

Figure 413: Maximum Transmitted Power, Middle Channel 5795 MHz of 802.11n HT40, 2 Data Stream, Chain 0 – 27 Mbps

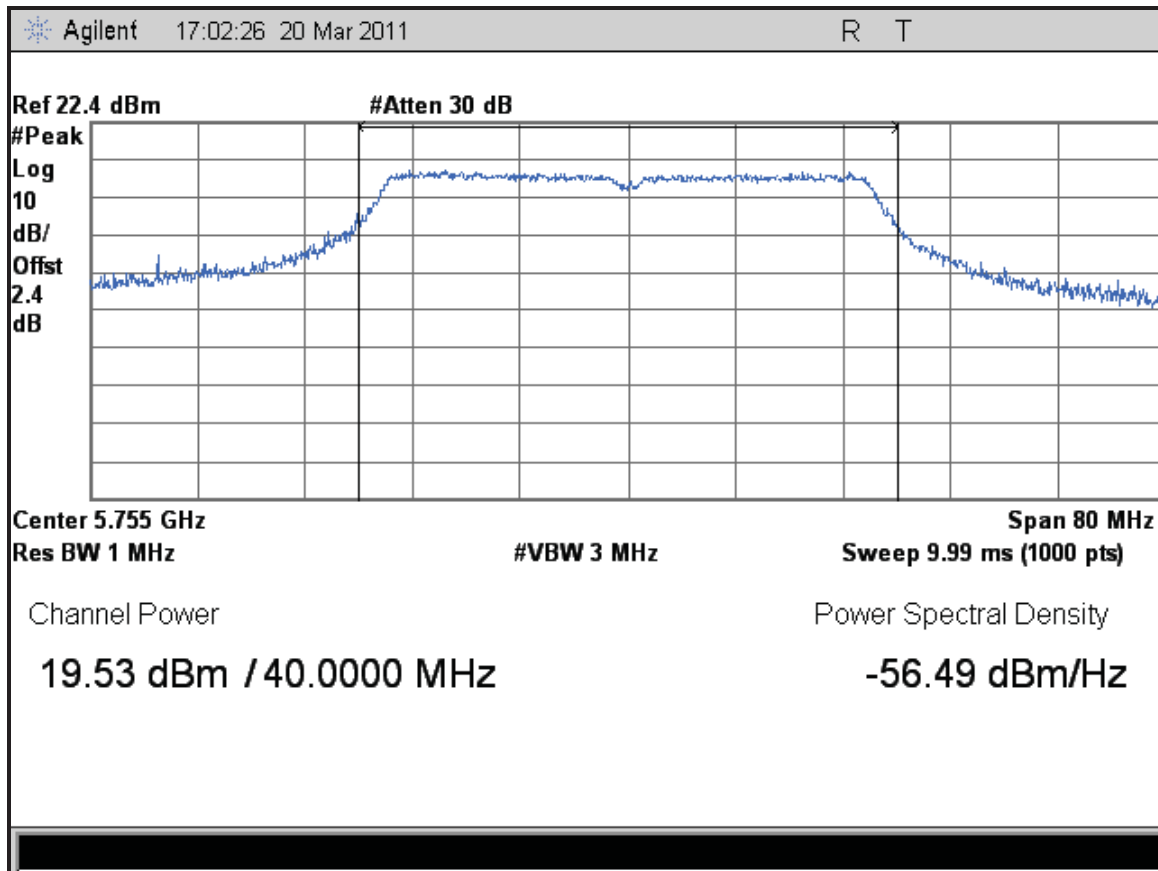

Figure 414: Maximum Transmitted Power, Lowest Channel 5755 MHz of 802.11n HT40, 2 Data Stream, Chain 1 – 27 Mbps

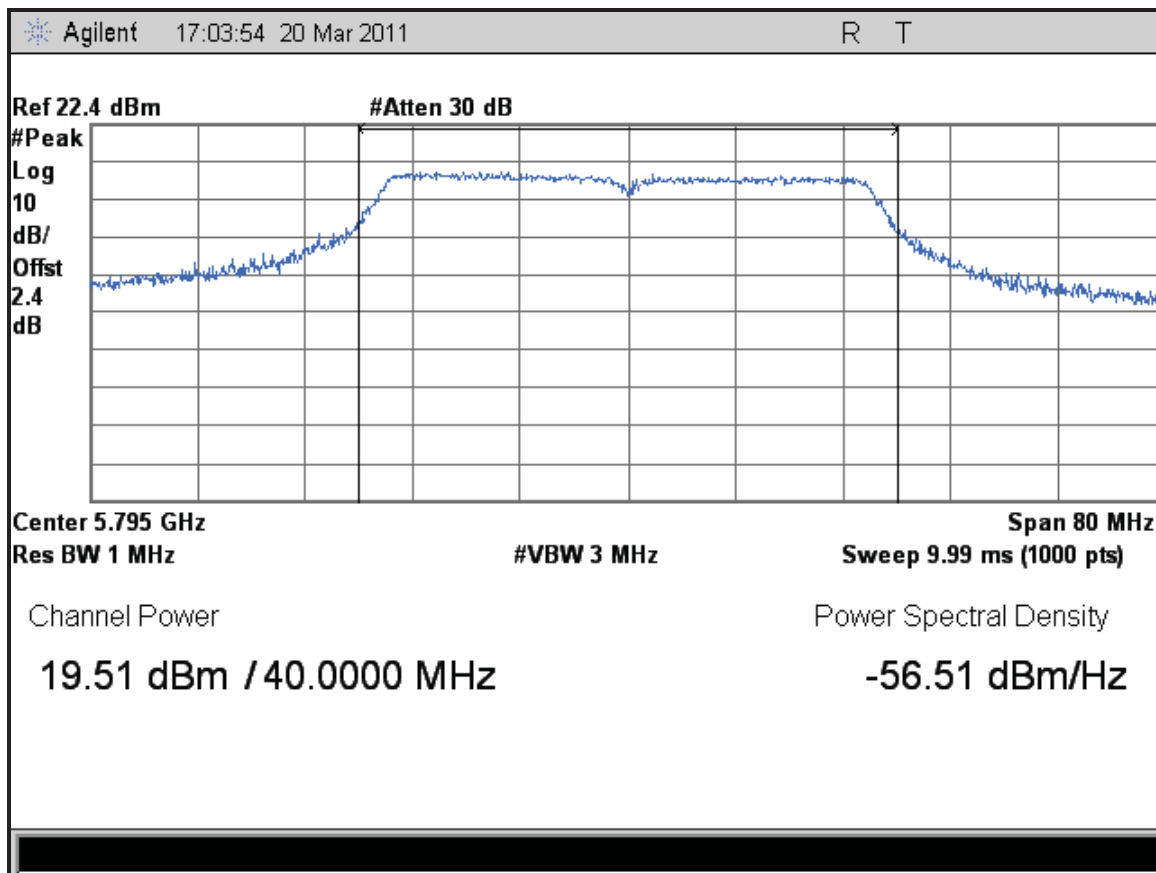

Figure 415: Maximum Transmitted Power, Middle Channel 5795 MHz of 802.11n HT40, 2 Data Stream, Chain 1 – 27 Mbps

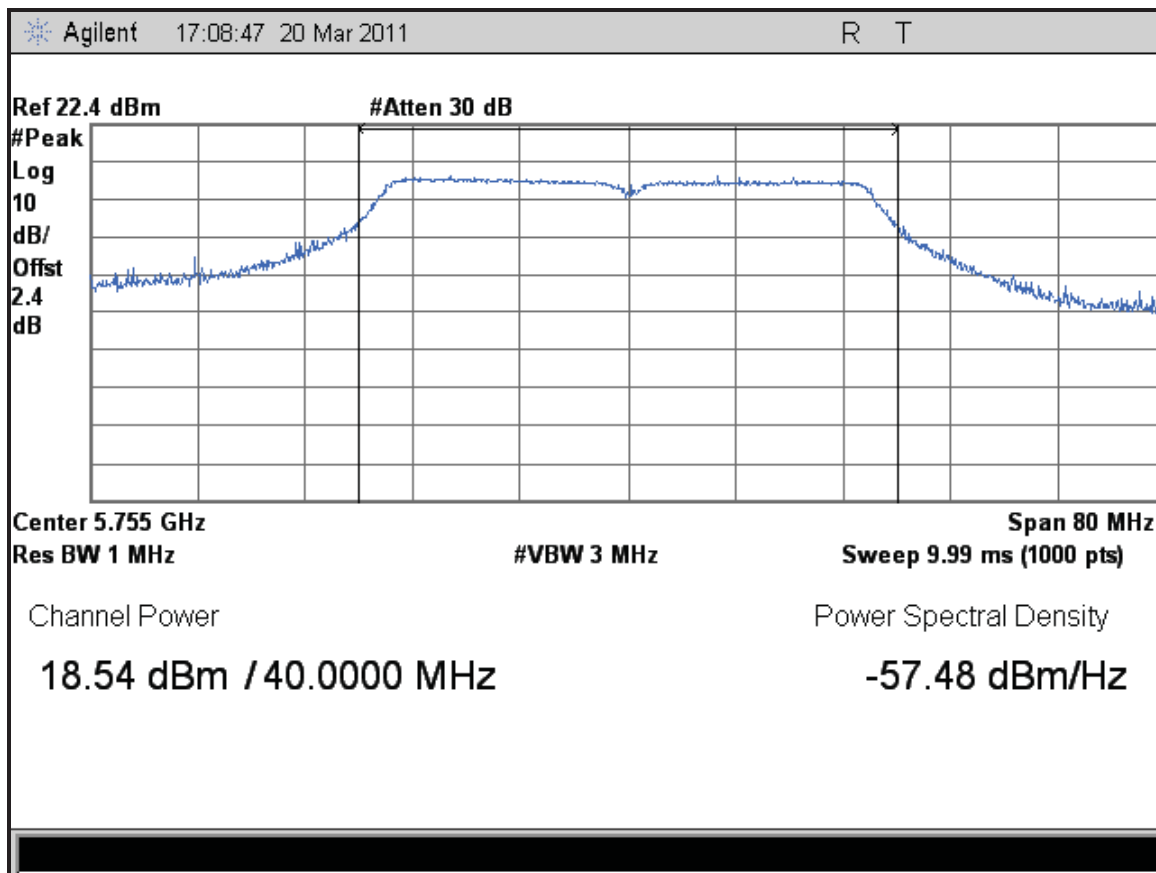

Figure 416: Maximum Transmitted Power, Lowest Channel 5755 MHz of 802.11n HT40, 3 Data Stream, Chain 0 – 40.5 Mbps

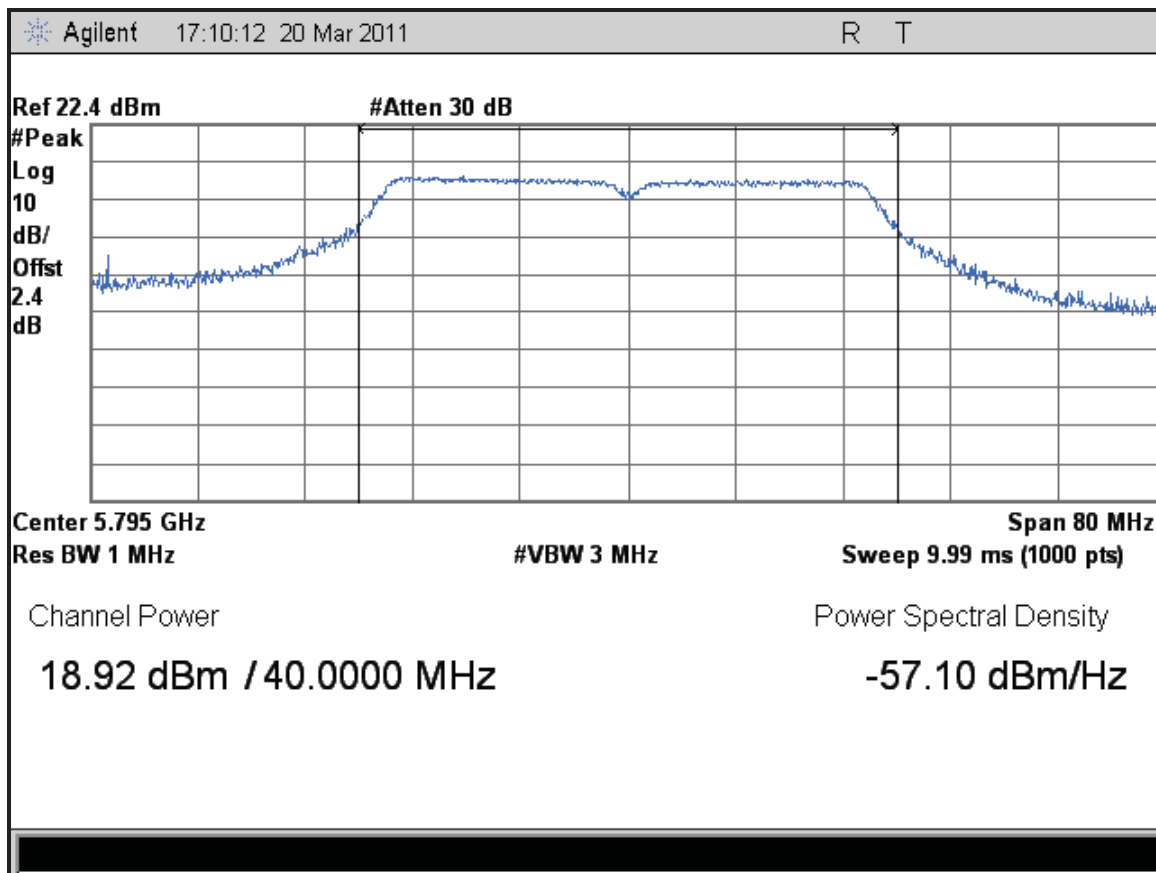

Figure 417: Maximum Transmitted Power, Middle Channel 5795 MHz of 802.11n HT40, 3 Data Stream, Chain 0 – 40.5 Mbps

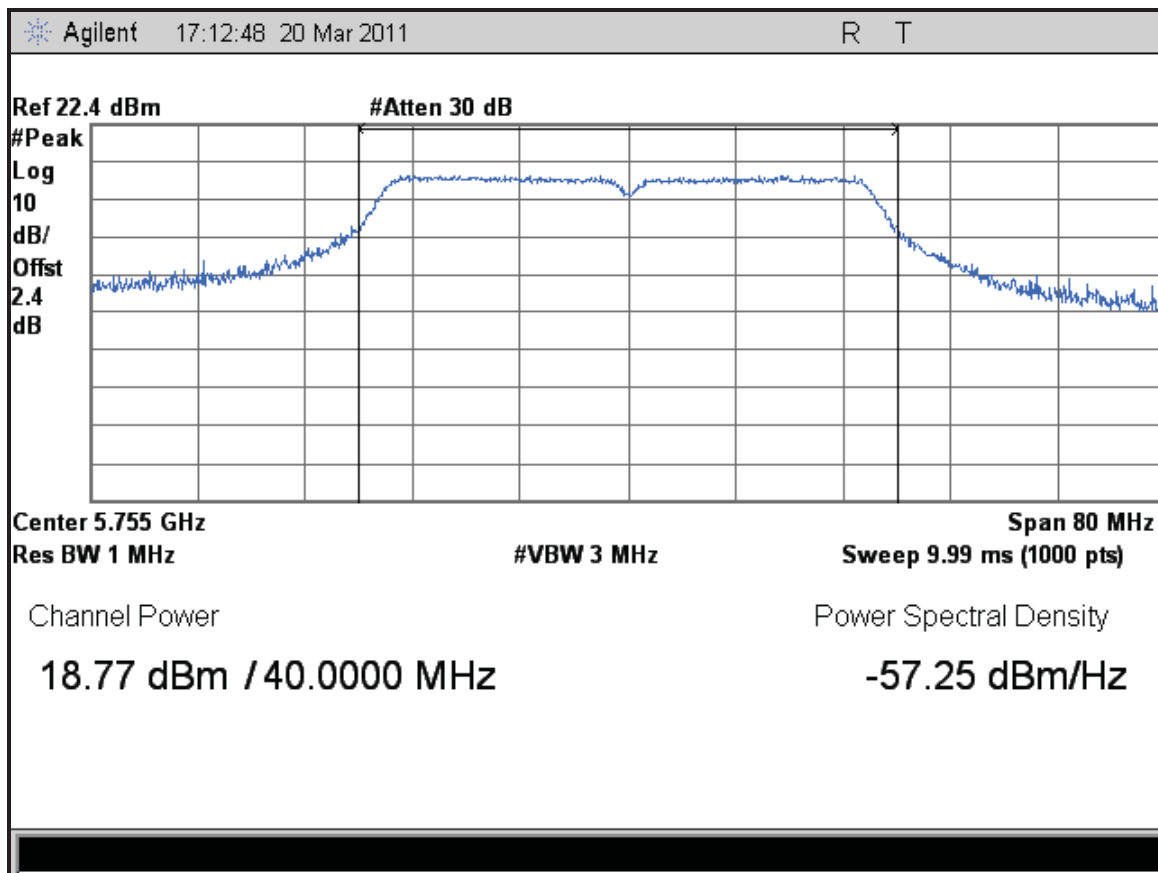

Figure 418: Maximum Transmitted Power, Lowest Channel 5755 MHz of 802.11n HT40, 3 Data Stream, Chain 1 – 40.5 Mbps

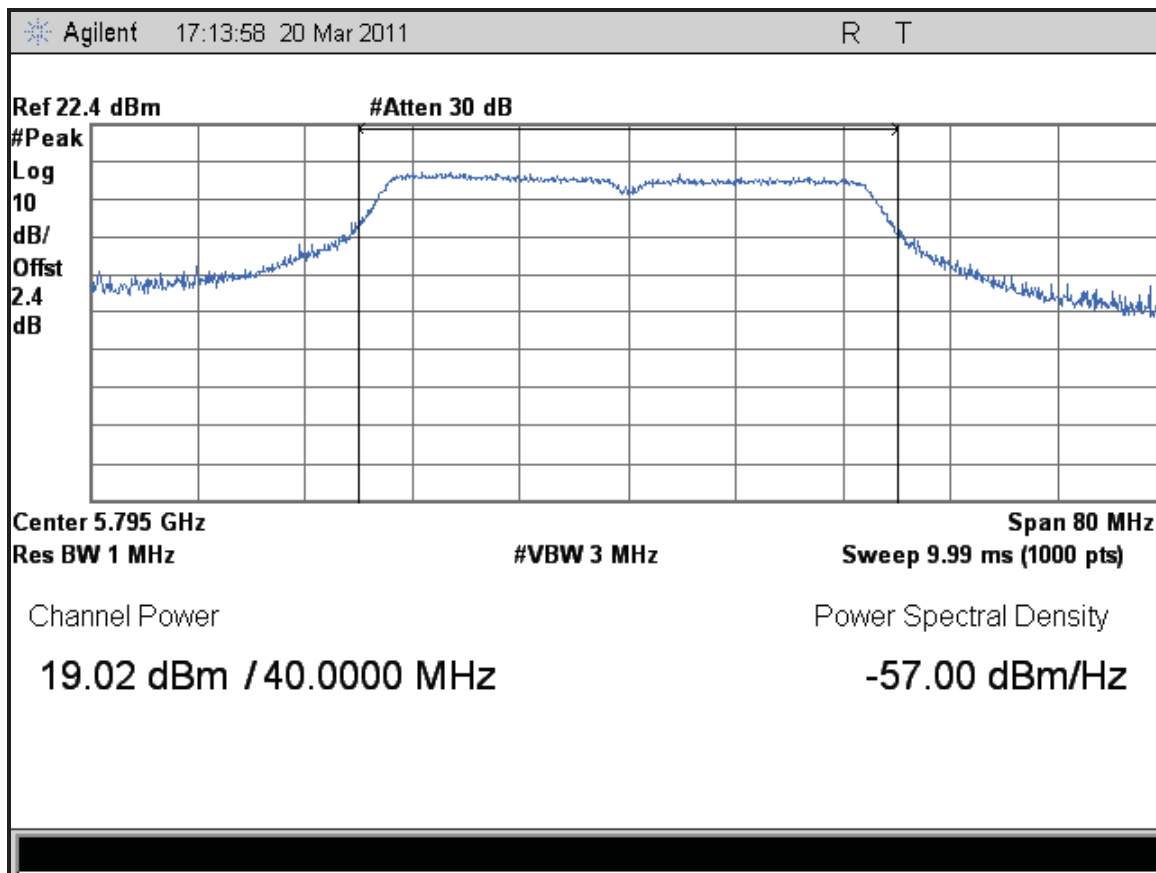

Figure 419: Maximum Transmitted Power, Middle Channel 5795 MHz of 802.11n HT40, 3 Data Stream, Chain 1 – 40.5 Mbps

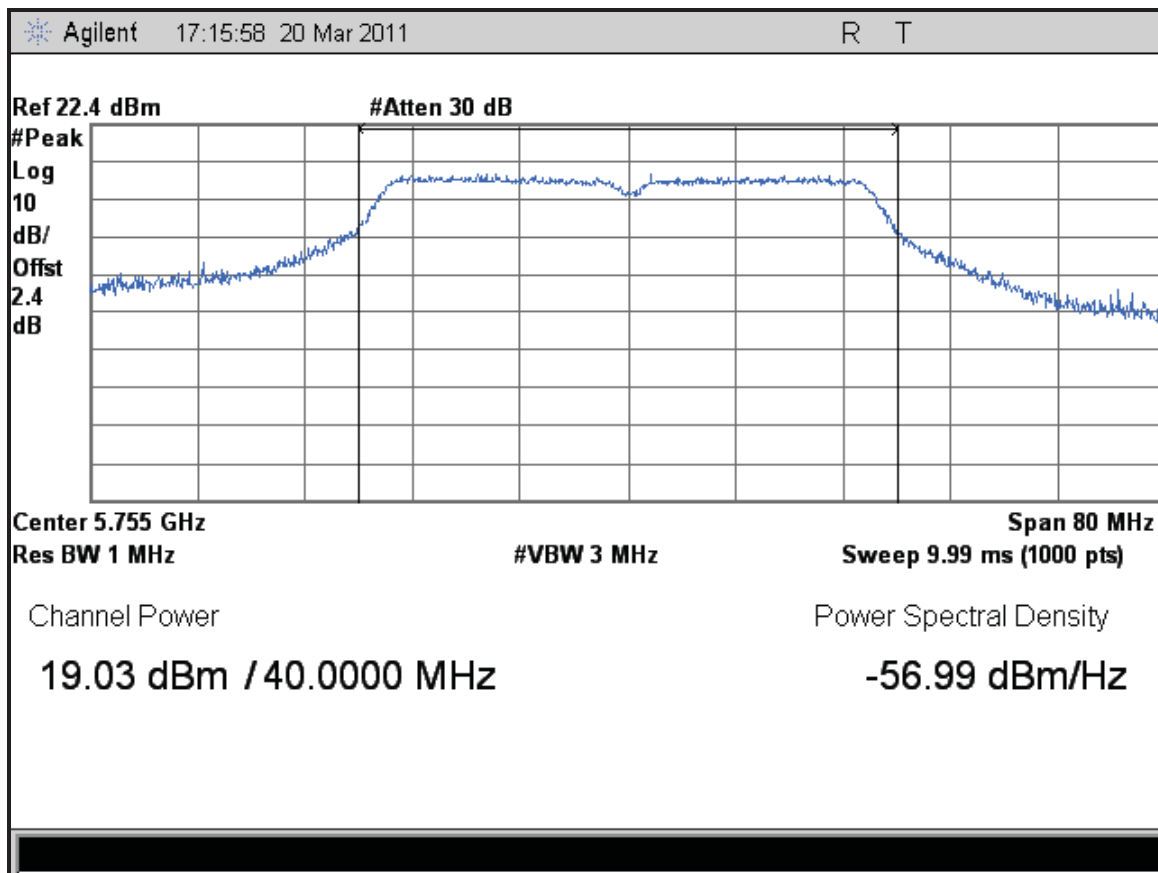

Figure 420: Maximum Transmitted Power, Lowest Channel 5755 MHz of 802.11n HT40, 3 Data Stream, Chain 2 – 40.5 Mbps

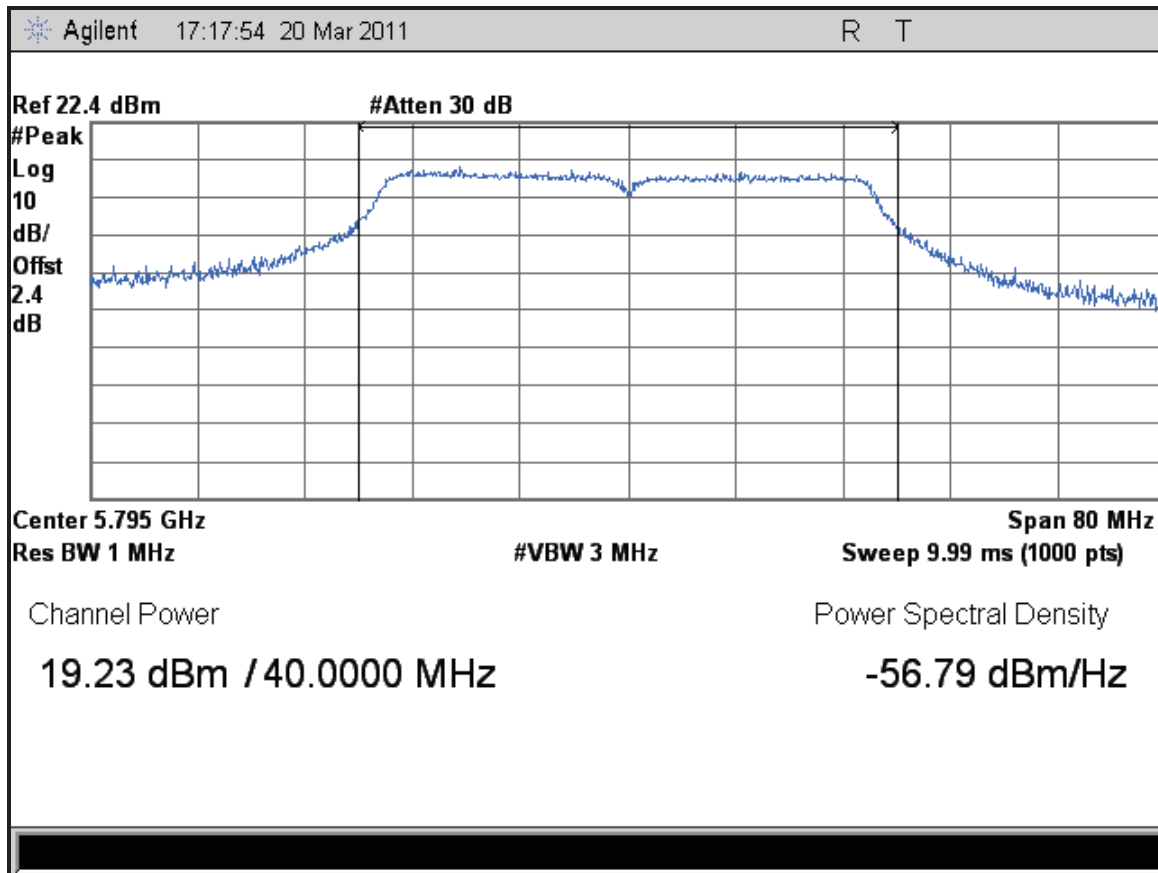

Figure 421: Maximum Transmitted Power, Middle Channel 5795 MHz of 802.11n HT40, 3 Data Stream, Chain 2 – 40.5 Mbps

5.2 Occupied Bandwidth

The occupied bandwidth is measured at an amplitude level reduced from the reference level by a specified ratio. The reference level is the level of the highest amplitude signal observed from the transmitter at the fundamental frequency.

The 99% bandwidth is the bandwidth in which 99% of the transmitted power occupied.

The 6 dB bandwidth is defined the bandwidth of 6 dBr from highest transmitted level of the fundamental frequency.

The bandwidth shall be at least 500 kHz per Section CFR47 15.247(a2) 2009 and RSS Gen Sect. 4.4.1: 2010.

5.2.1 Test Method

The conducted method was used to measure the channel power output. The measurement was performed with modulation per CFR47 15.247(a2) 2009 and RSS Gen Sect. 4.4.1:2010. Initial investigation was performed at different data rates and TX chains. The narrowest bandwidths at each operational mode were measured on 3 operating channels. The worst sample result indicated below.

Test Setup:

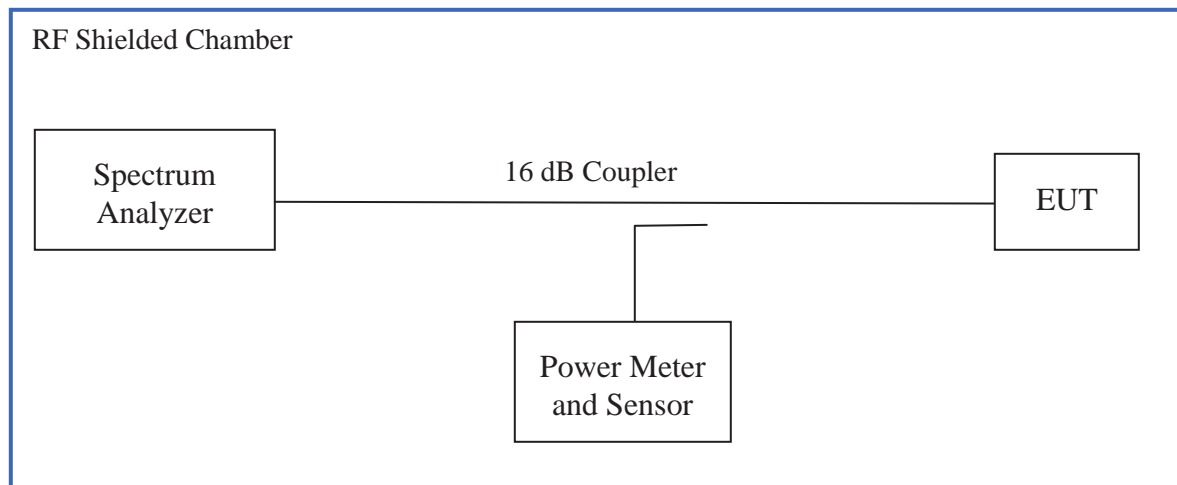

5.2.2 Results

As originally tested, the EUT was found to be compliant to the requirements of the test standard(s).

Table 10: Occupied Bandwidth – Test Results

Test Conditions: Conducted Measurement, Normal Temperature and Voltage only								
Antenna Type: Integrated				Power Setting: See test plan				
Max. Antenna Gain: + 3.2 dBi				Signal State: Modulated				
Ambient Temp.: 21 °C				Relative Humidity: 37%				
Bandwidth (MHz) for 802.11a								
Freq. (MHz)	Limit (kHz)	Ch 0 99% BW	Ch 1 99% BW	Ch 2 99% BW	Ch 0 6 dB BW	Ch 1 6 dB BW	Ch 2 6 dB BW	Results
5745	500	17.814	17.581	17.833	16.536	16.530	16.556	Pass
5785	500	17.719	17.611	17.675	16.537	16.507	16.540	Pass
5825	500	17.803	17.607	17.701	16.502	16.546	16.567	Pass
Note: The narrowest bandwidth was observed at 6Mbps for 802.11a mode.								
Bandwidth (MHz) for 802.11n HT20								
Freq. (MHz)	Limit (kHz)	Ch 0 99% BW	Ch 1 99% BW	Ch 2 99% BW	Ch 0 6 dB BW	Ch 1 6 dB BW	Ch 2 6 dB BW	Results
5745	500	17.558	17.413	17.466	16.530	16.632	16.684	Pass
5785	500	17.510	17.444	17.315	16.538	16.543	16.568	Pass
5825	500	17.537	17.370	17.412	16.562	16.533	16.625	Pass
Note: The narrowest bandwidth was observed at 39Mbps for 802.11n HT20 mode, 1 data stream								
Bandwidth (MHz) for 802.11n HT40								
Freq. (MHz)	Limit (kHz)	Ch 0 99% BW	Ch 1 99% BW	Ch 2 99% BW	Ch 0 6 dB BW	Ch 1 6 dB BW	Ch 2 6 dB BW	Results
5755	500	40.948	39.779	40.019	36.623	37.026	37.571	Pass
5795	500	39.620	39.904	40.307	36.964	36.484	36.661	Pass
Note: The bandwidth was observed at 13.5 Mbps at 1 data stream								

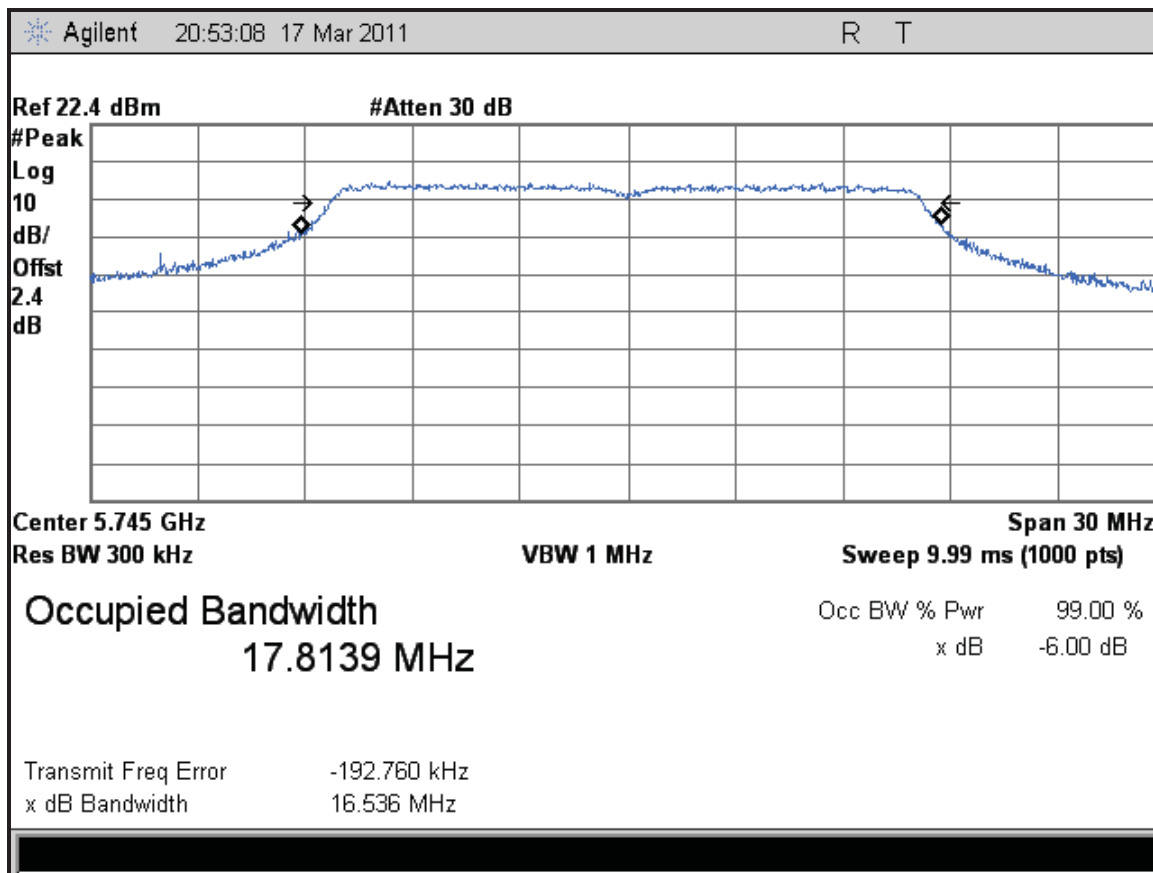

Figure 422: Occupied Bandwidth at 802.11a, 5745MHz - Chain 0 (6Mbps)

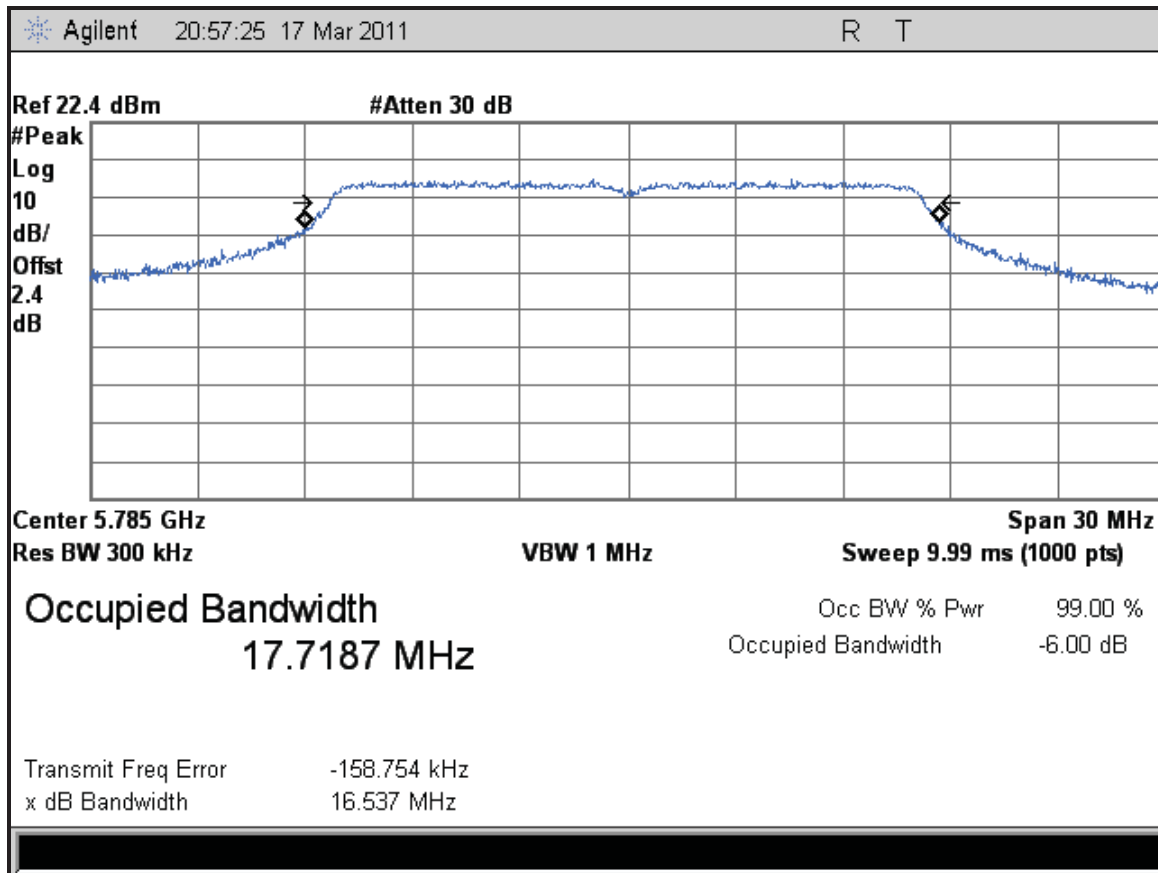

Figure 423: Occupied Bandwidth at 802.11a, 5785MHz - Chain 0 (6Mbps)

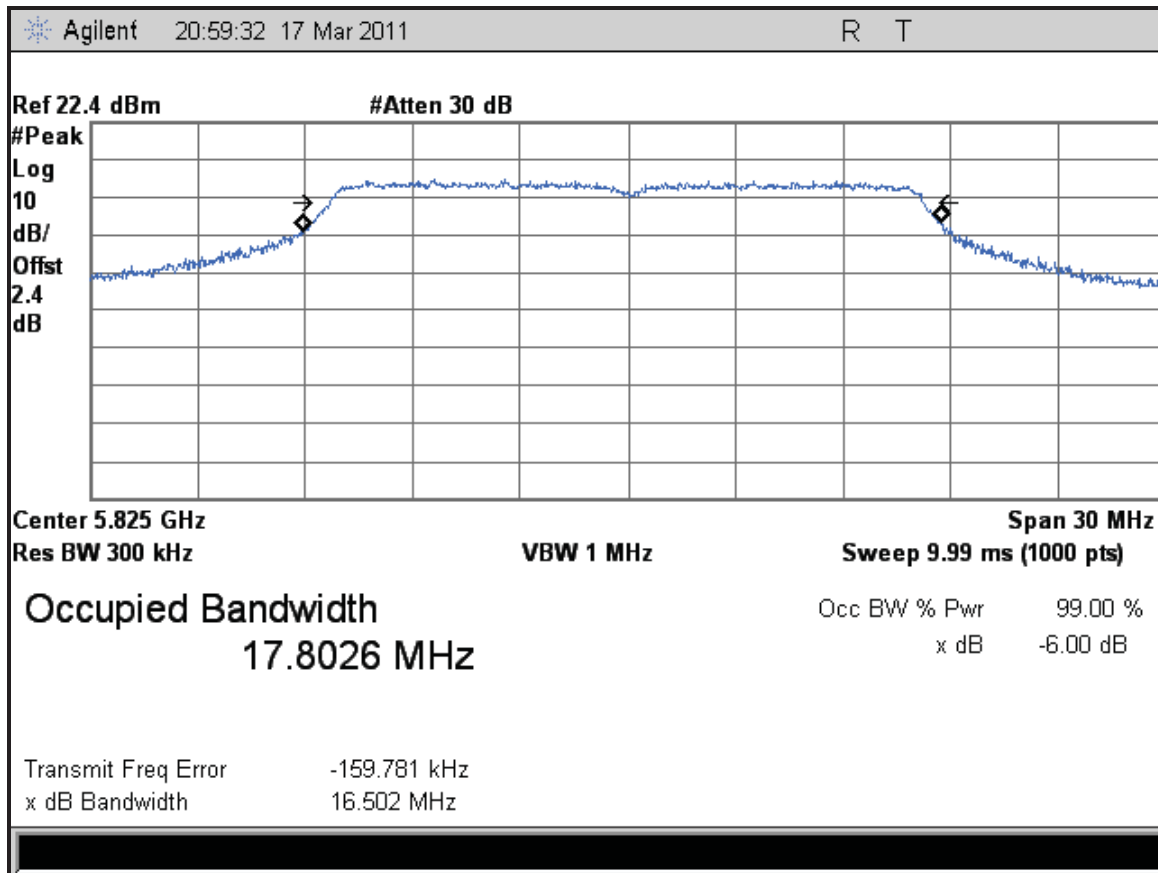

Figure 424: Occupied Bandwidth at 802.11a, 5825MHz - Chain 0 (6Mbps)

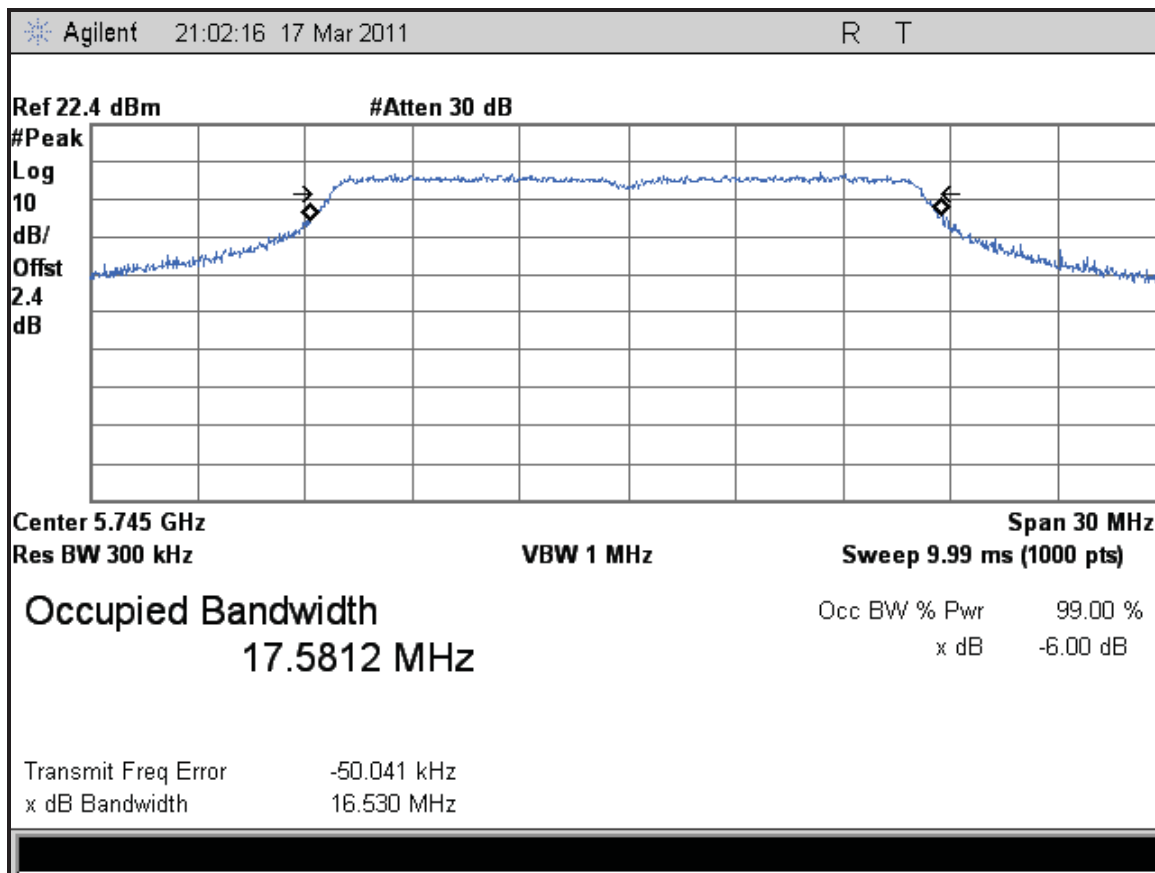

Figure 425: Occupied Bandwidth at 802.11a, 5745MHz - Chain 1 (6Mbps)

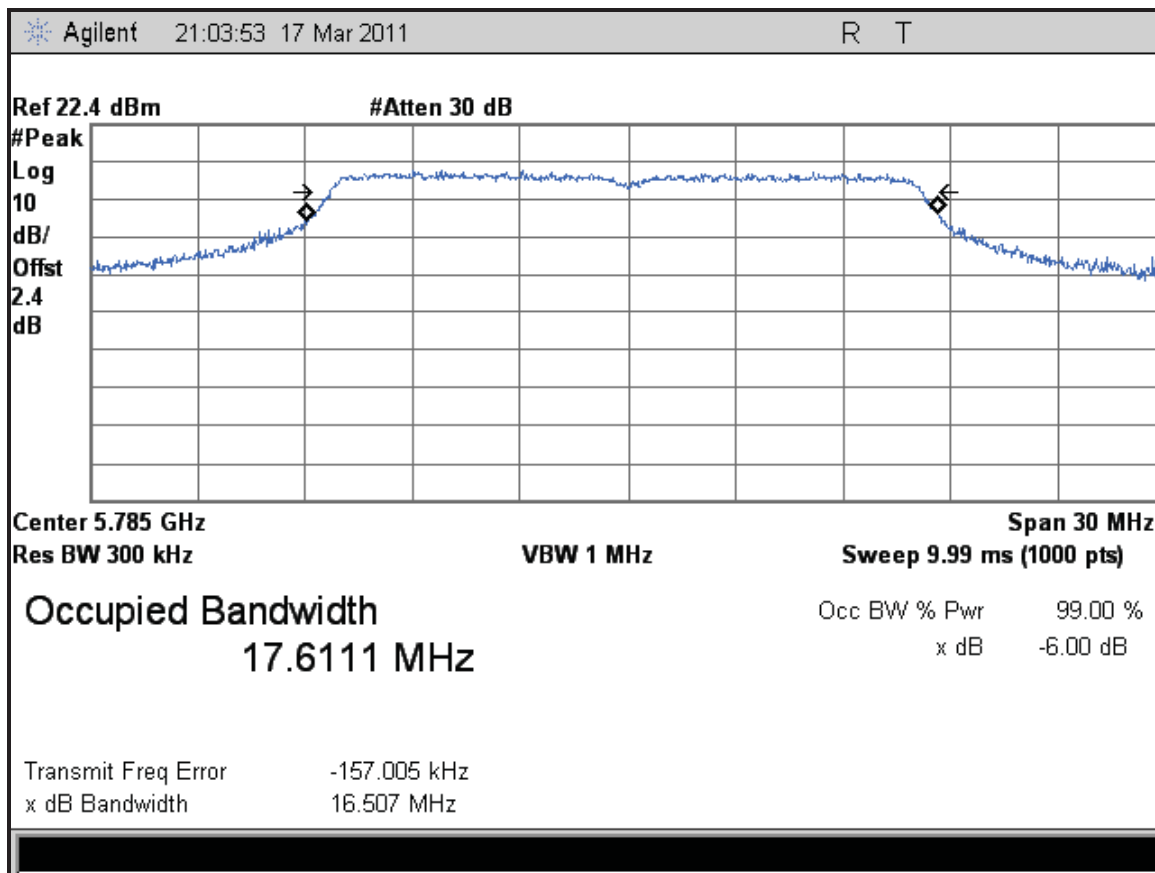

Figure 426: Occupied Bandwidth at 802.11a, 5785MHz - Chain 1 (6Mbps)

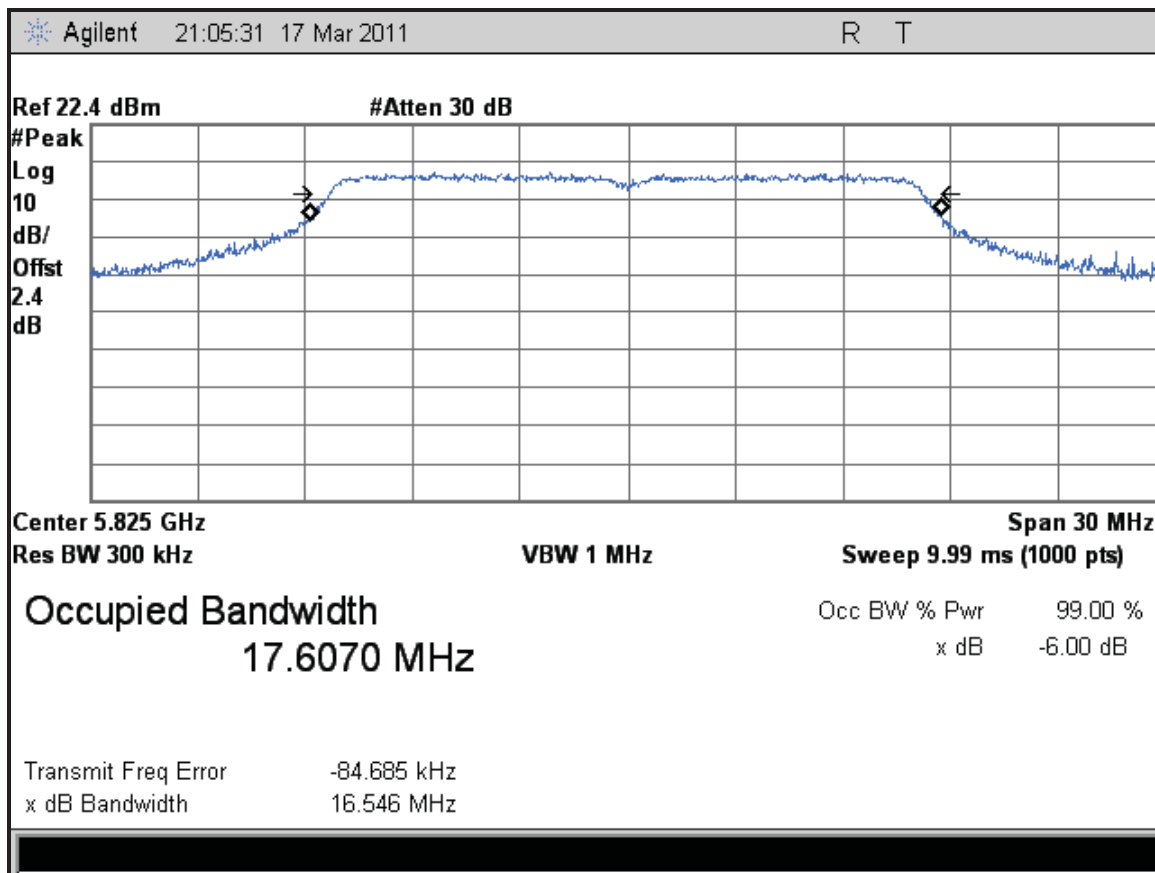

Figure 427: Occupied Bandwidth at 802.11a, 5825MHz - Chain 1 (6Mbps)

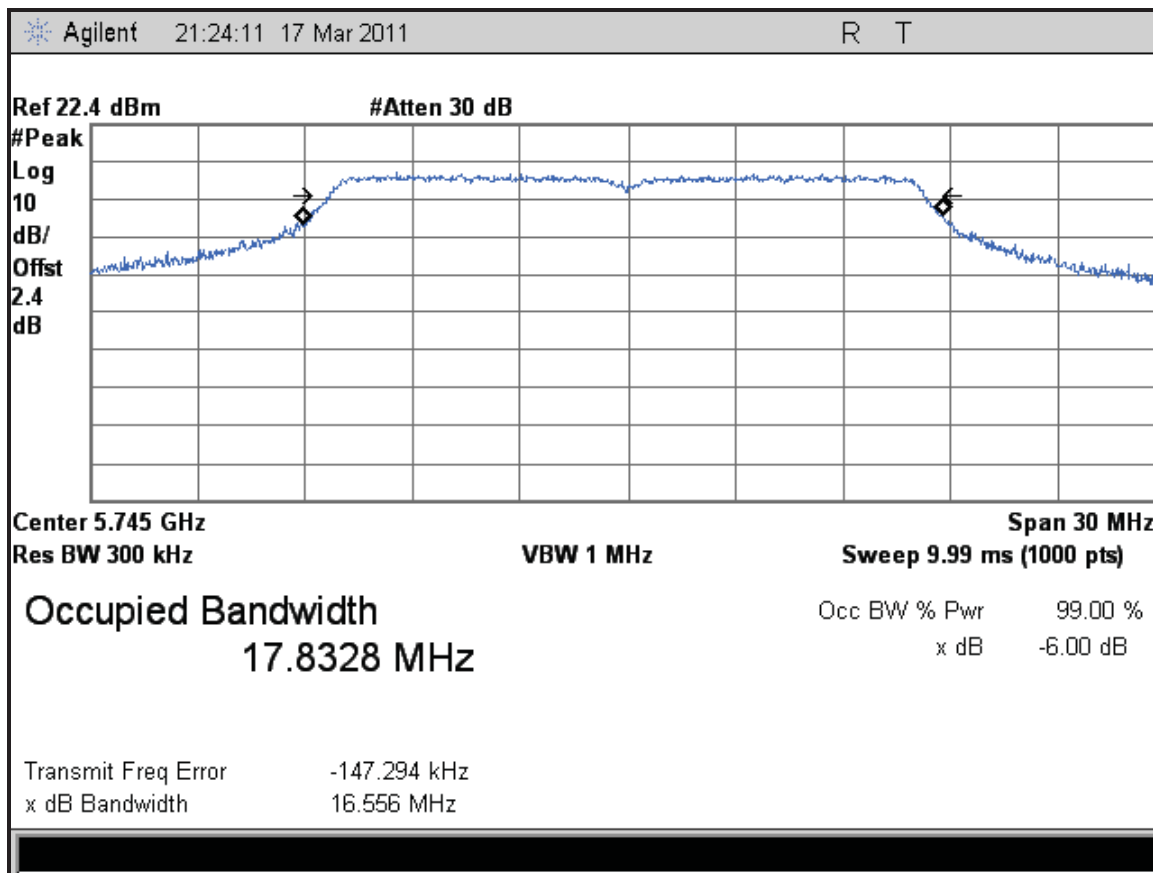

Figure 428: Occupied Bandwidth at 802.11a, 5745MHz - Chain 2 (6Mbps)

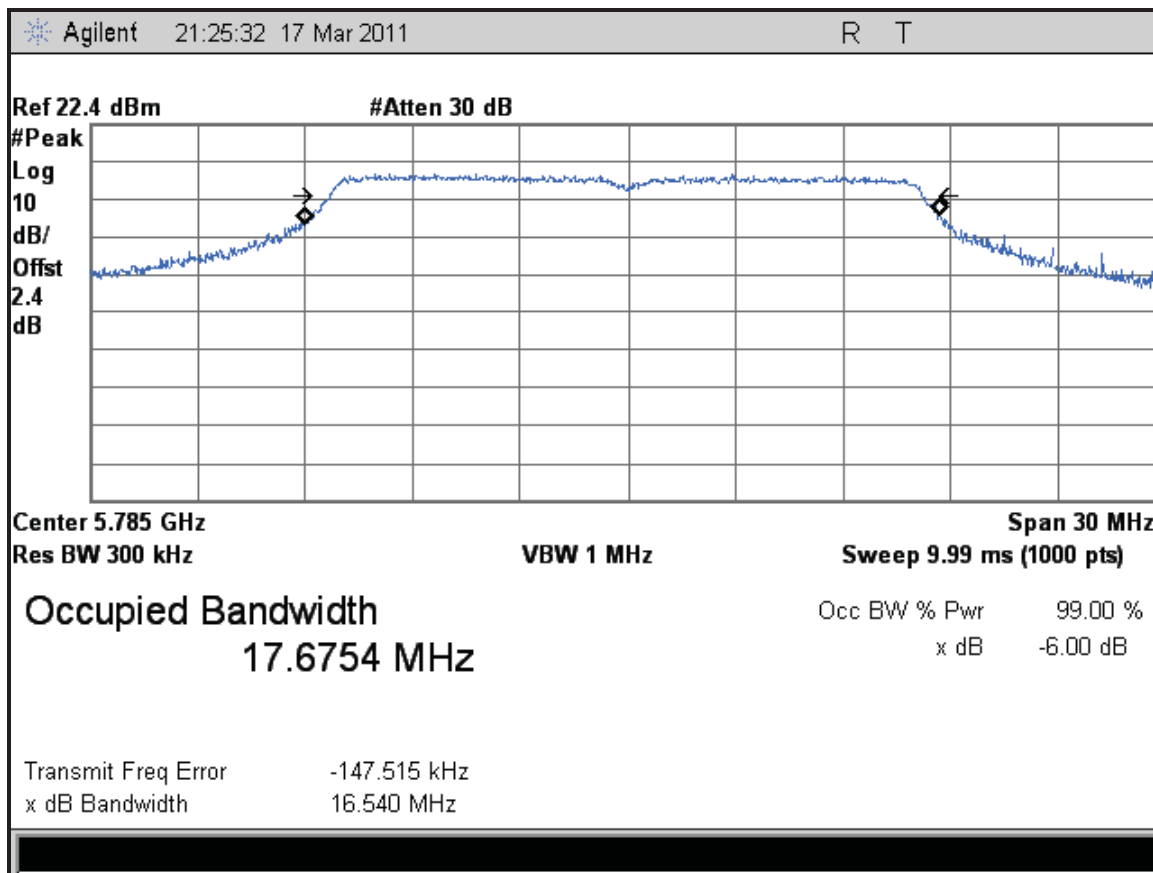

Figure 429: Occupied Bandwidth at 802.11a, 5785MHz - Chain 2 (6Mbps)

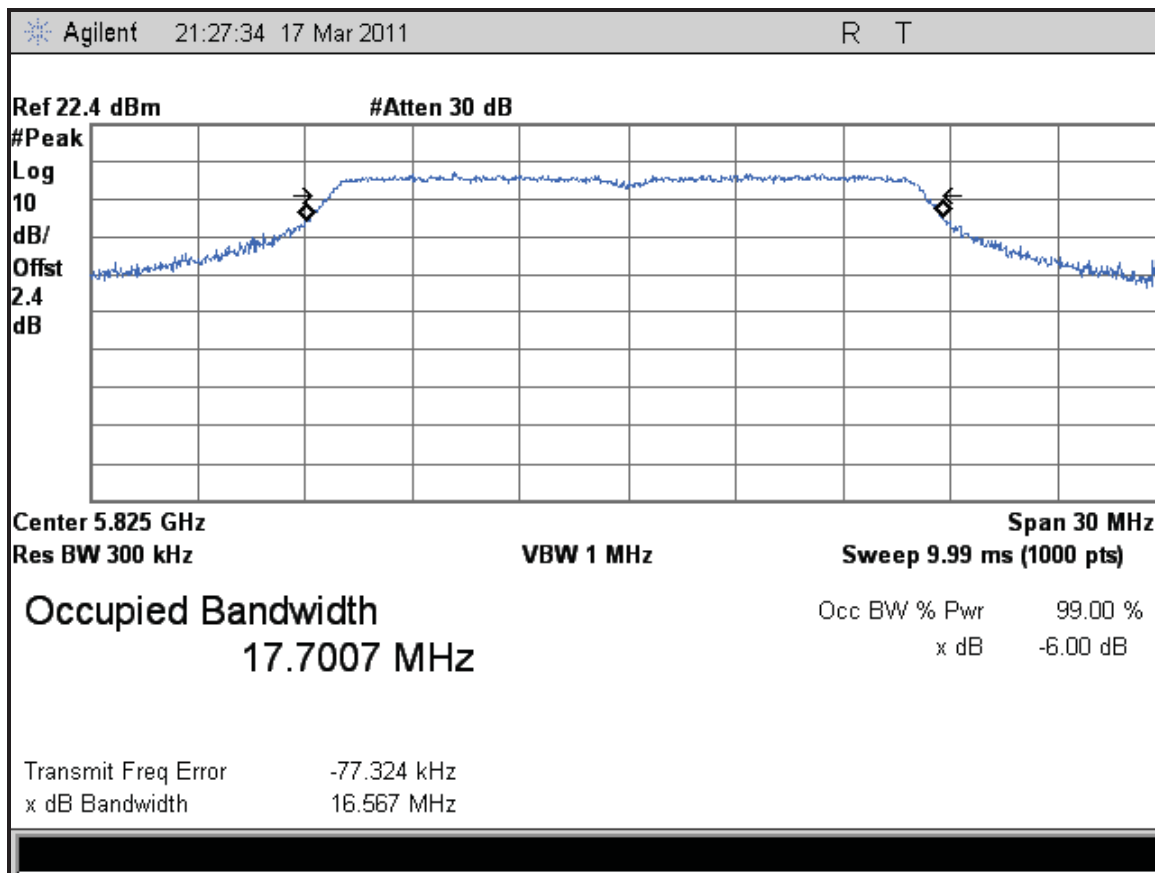

Figure 430: Occupied Bandwidth at 802.11a, 5825MHz - Chain 2 (6Mbps)

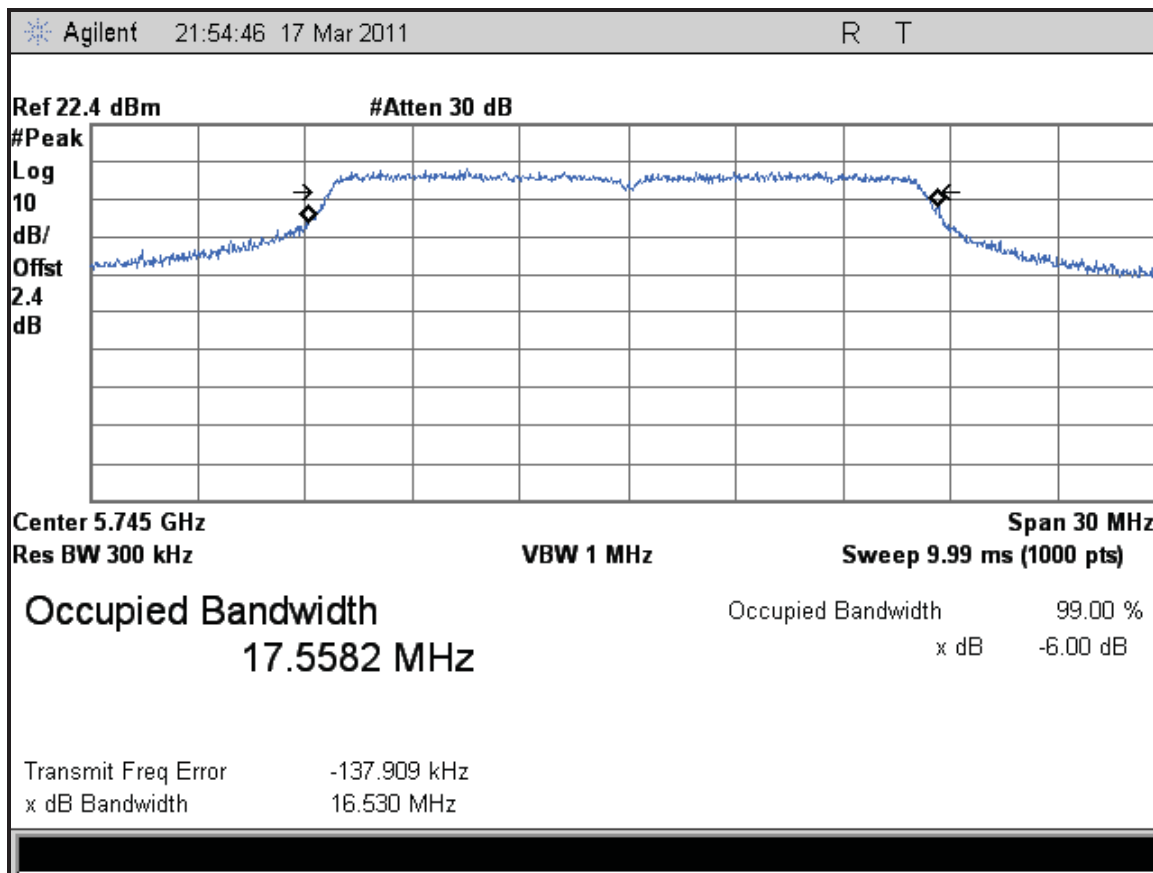

Figure 431: Occupied Bandwidth at 802.11n HT20, 5745MHz - Chain 0 (39Mbps)

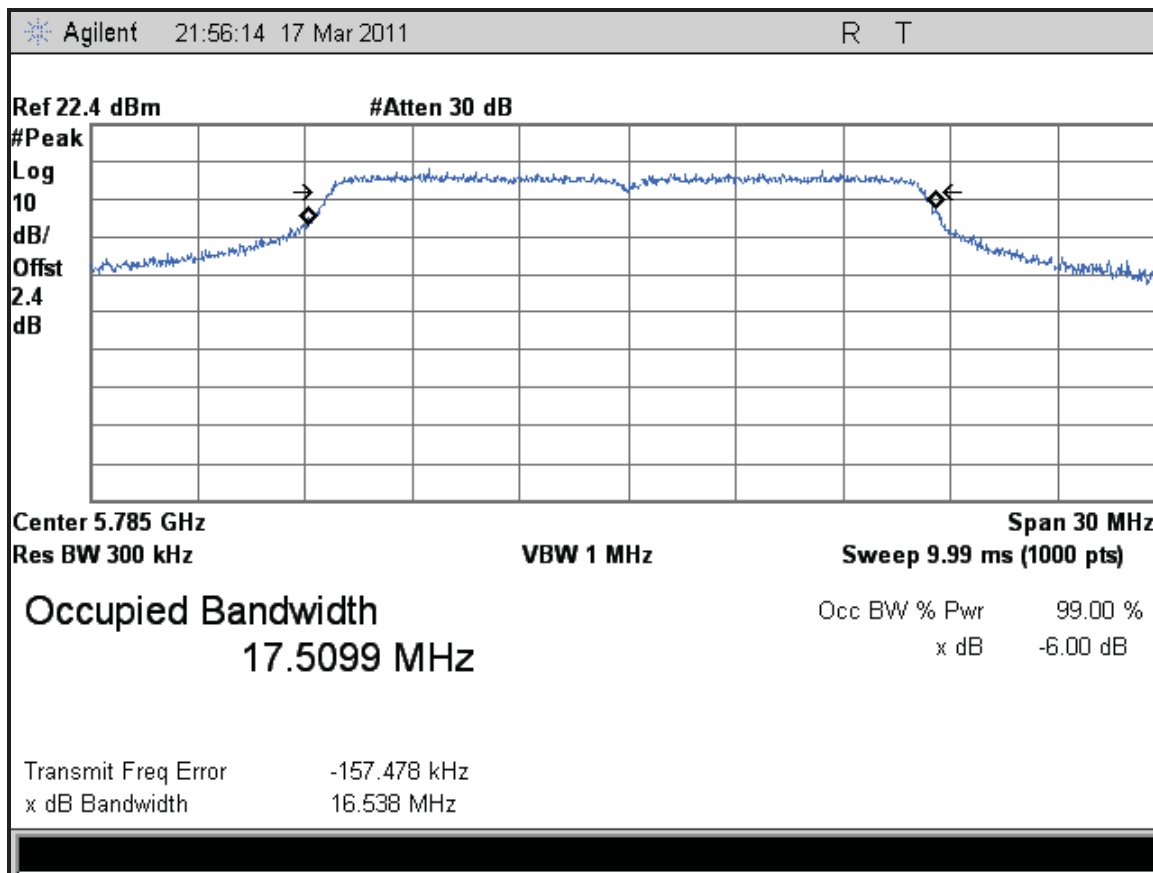

Figure 432: Occupied Bandwidth at 802.11n HT20, 5785MHz - Chain 0 (39Mbps)

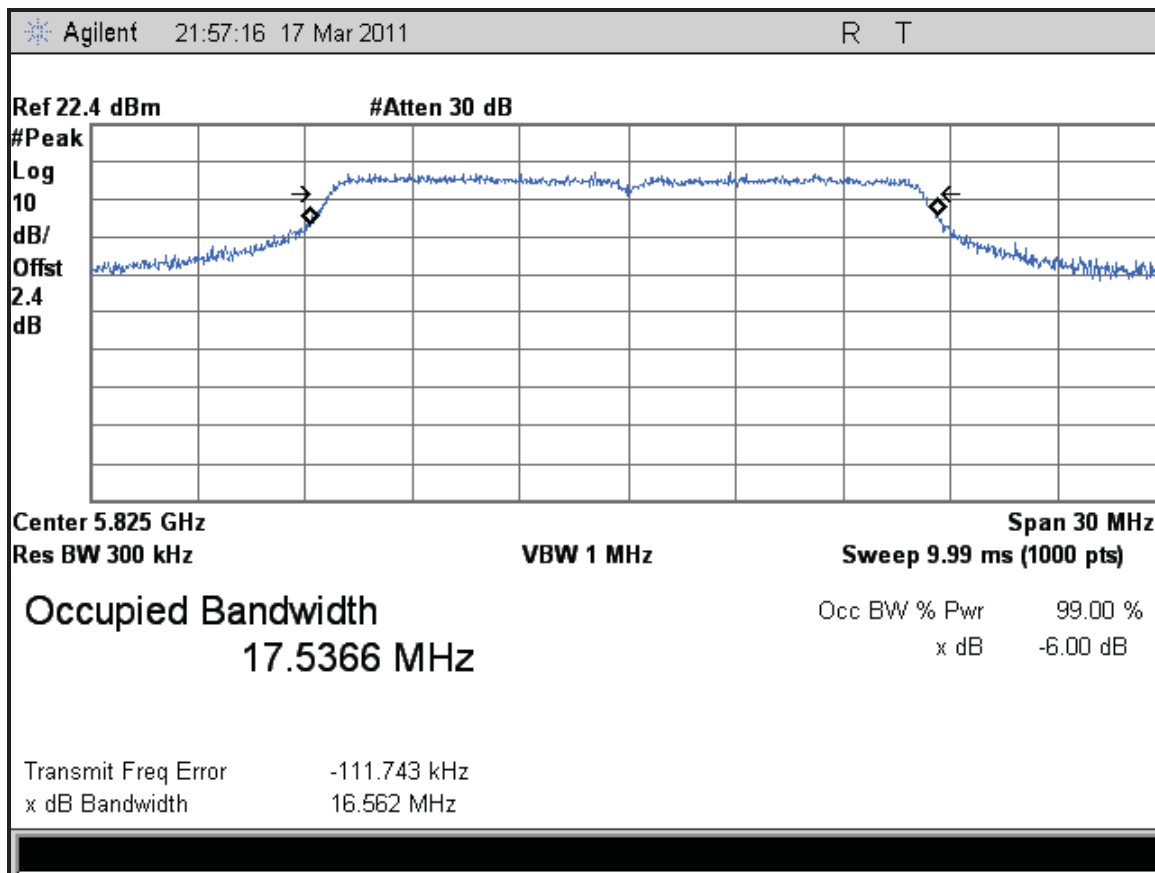

Figure 433: Occupied Bandwidth at 802.11n HT20, 5825MHz - Chain 0 (39Mbps)

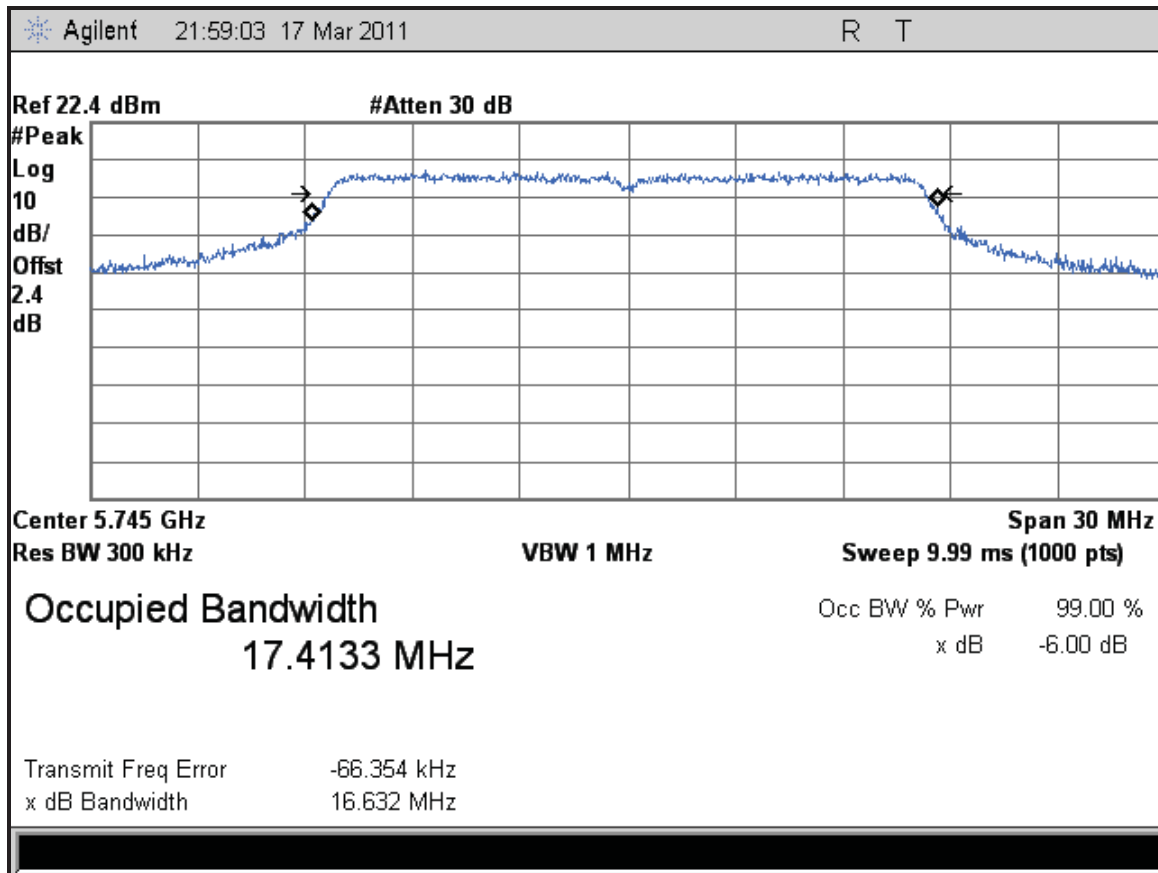

Figure 434: Occupied Bandwidth at 802.11n HT20, 5745MHz - Chain 1 (39Mbps)

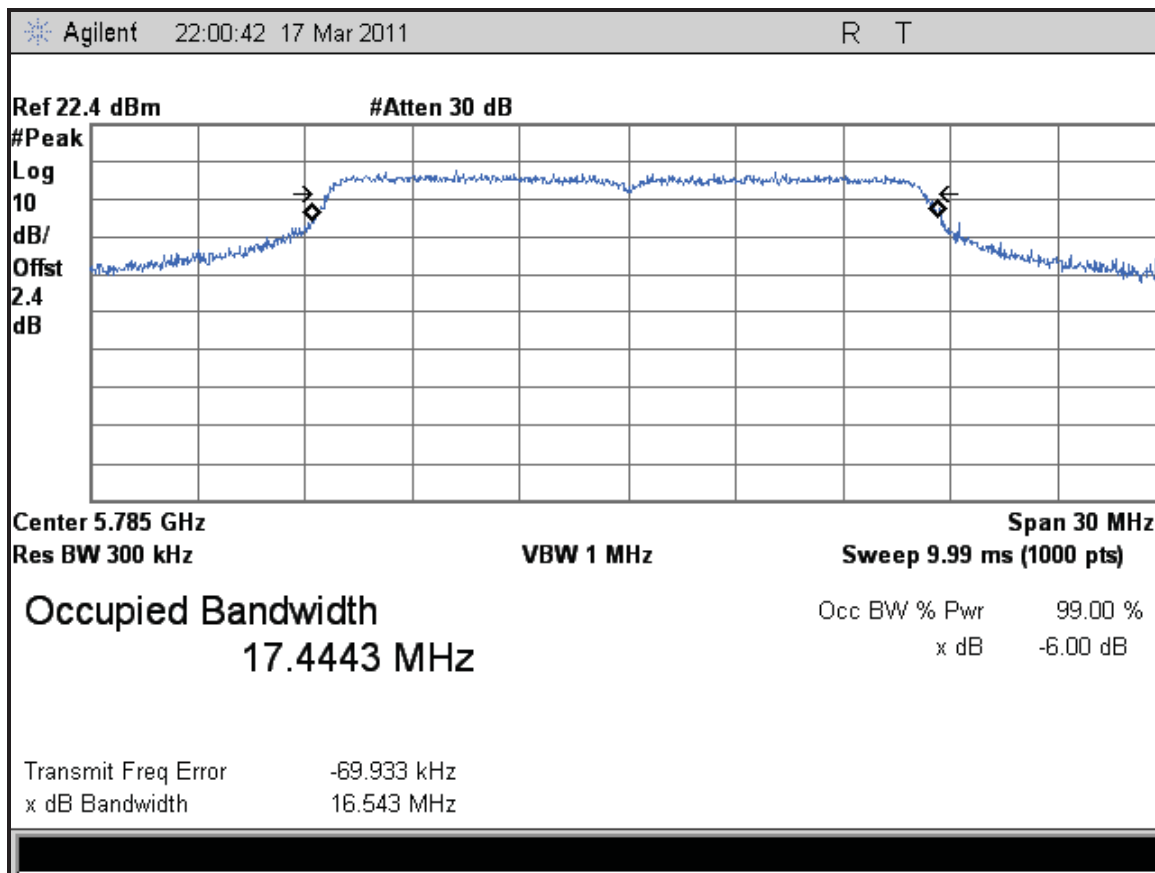

Figure 435: Occupied Bandwidth at 802.11n HT20, 5785MHz - Chain 1 (39Mbps)

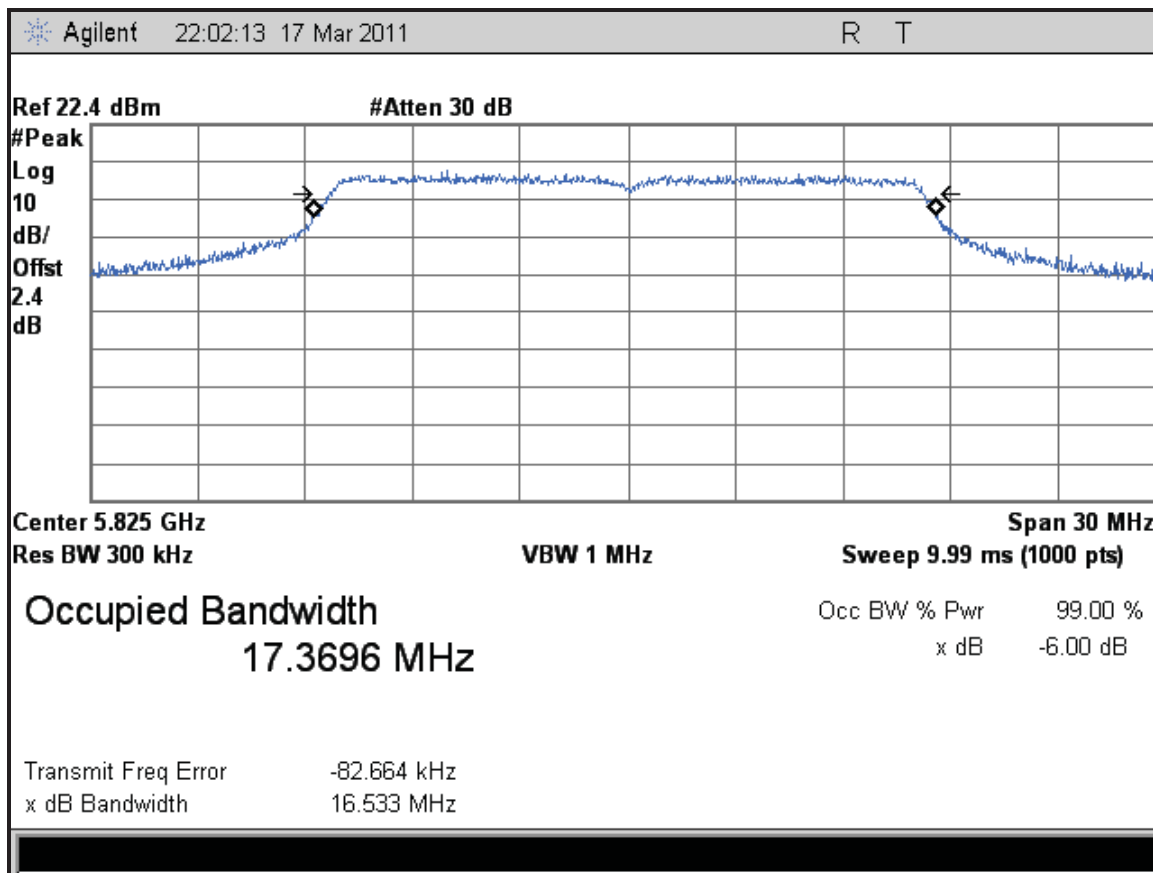

Figure 436: Occupied Bandwidth at 802.11n HT20, 5825MHz - Chain 1 (39Mbps)

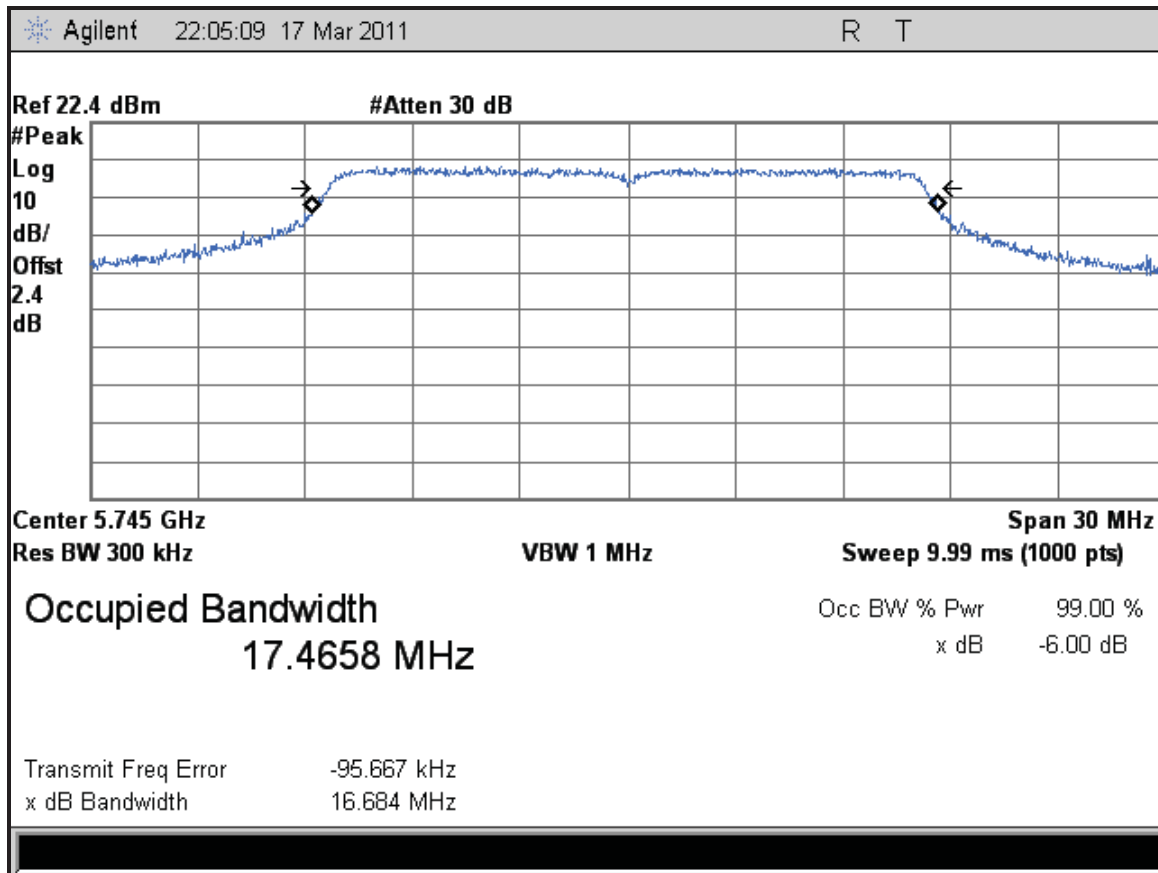

Figure 437: Occupied Bandwidth at 802.11n HT20, 5745MHz - Chain 2 (39Mbps)

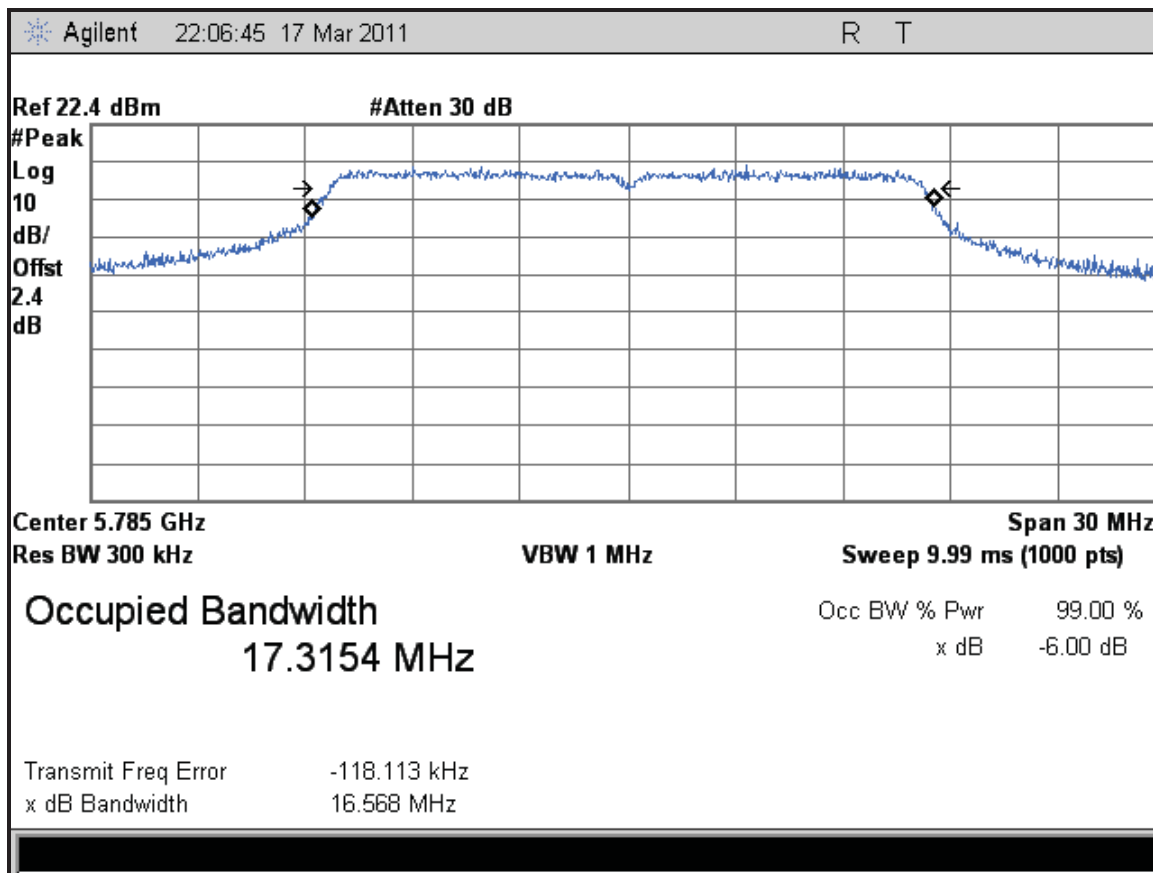

Figure 438: Occupied Bandwidth at 802.11n HT20, 5785MHz - Chain 2 (39Mbps)

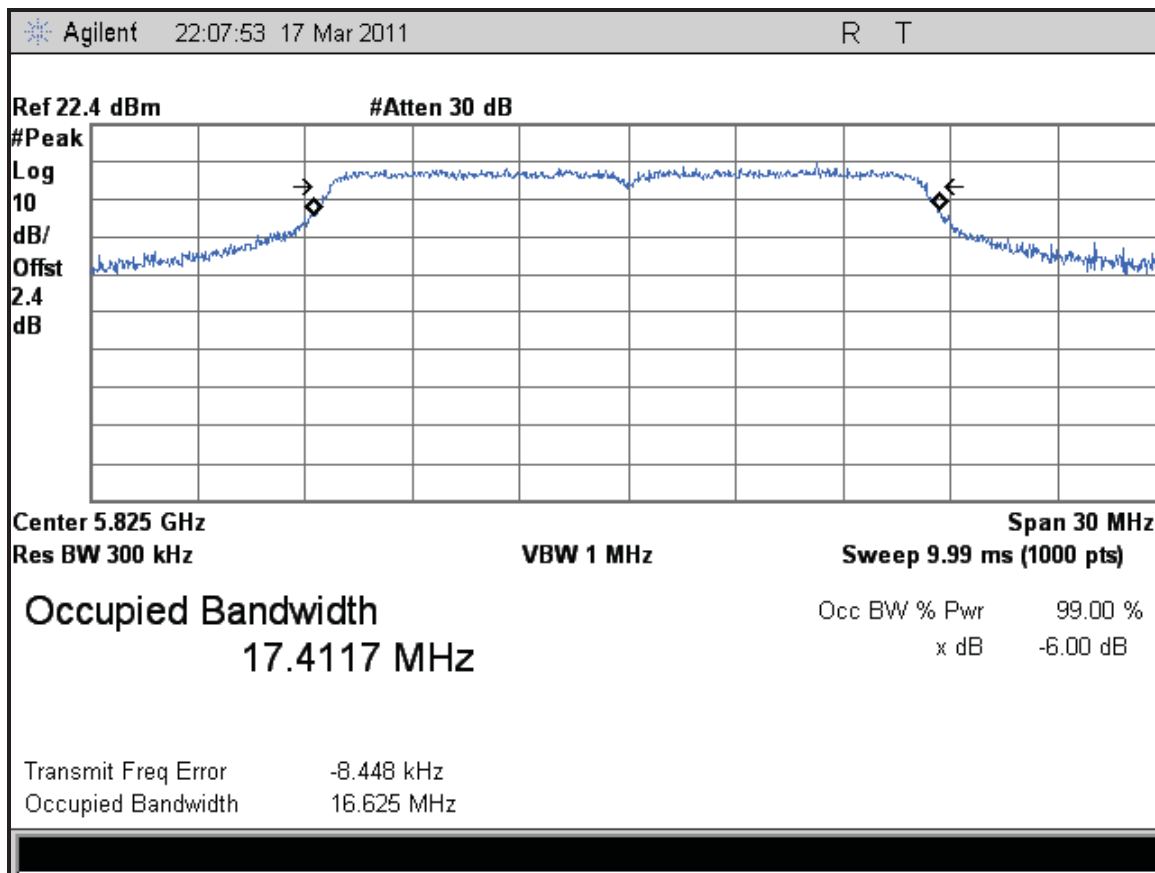

Figure 439: Occupied Bandwidth at 802.11n HT20, 5825MHz - Chain 2 (39Mbps)

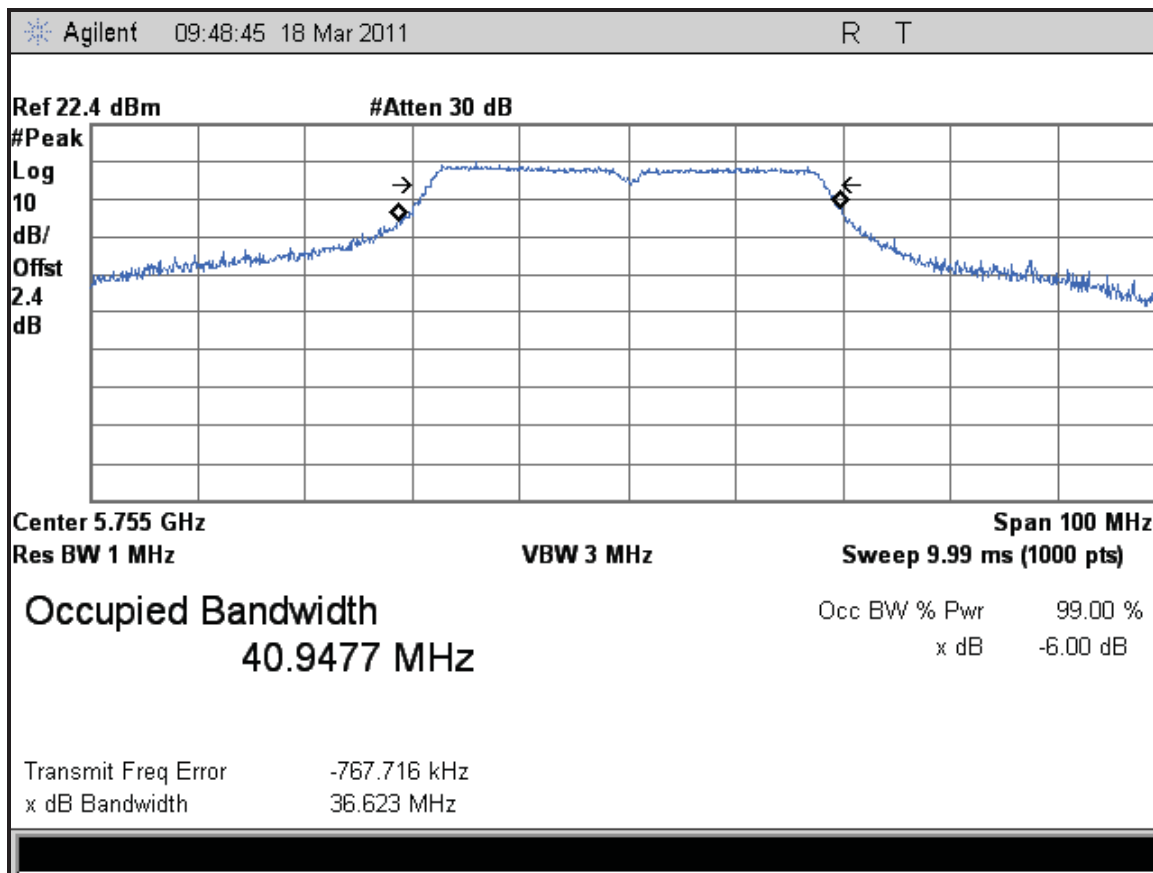

Figure 440: Occupied Bandwidth at 802.11n HT40, 5755MHz - Chain 0 (13.5Mbps)

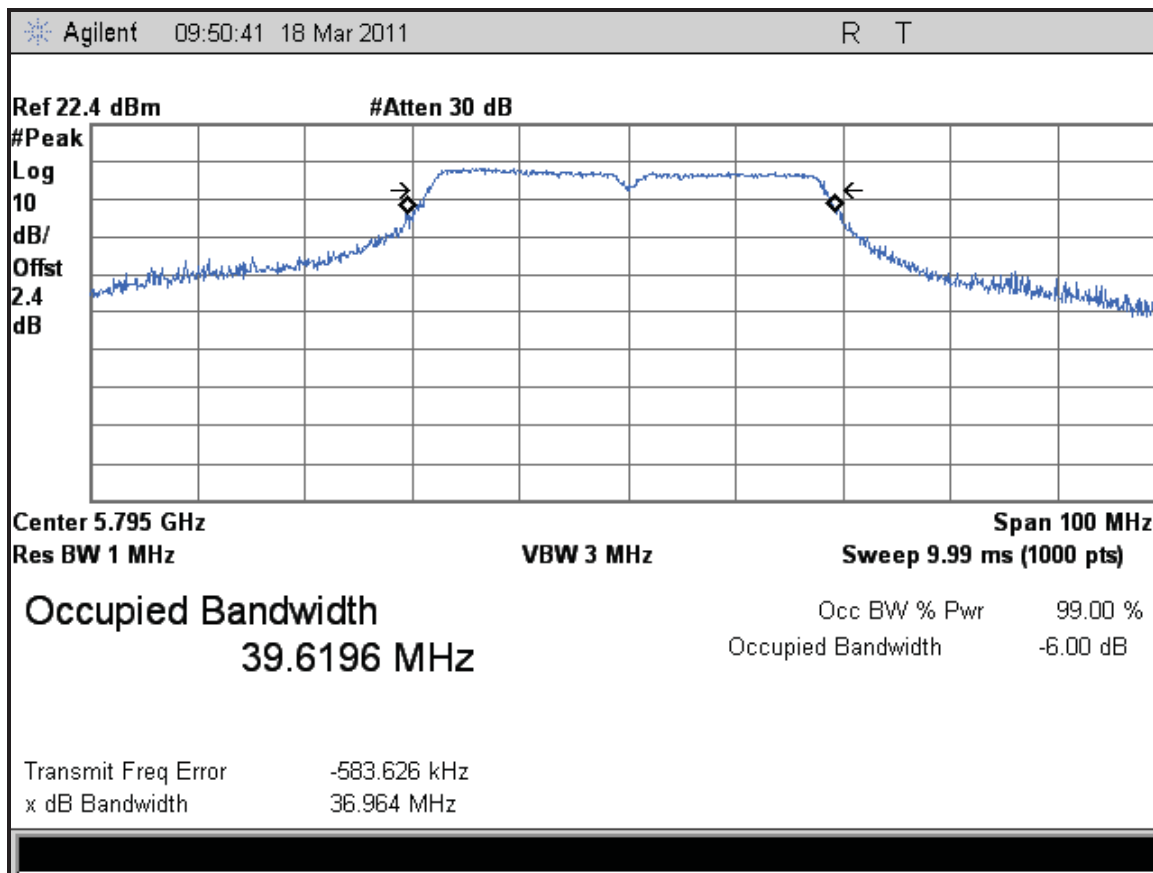

Figure 441: Occupied Bandwidth at 802.11n HT40, 5795MHz - Chain 0 (13.5Mbps)

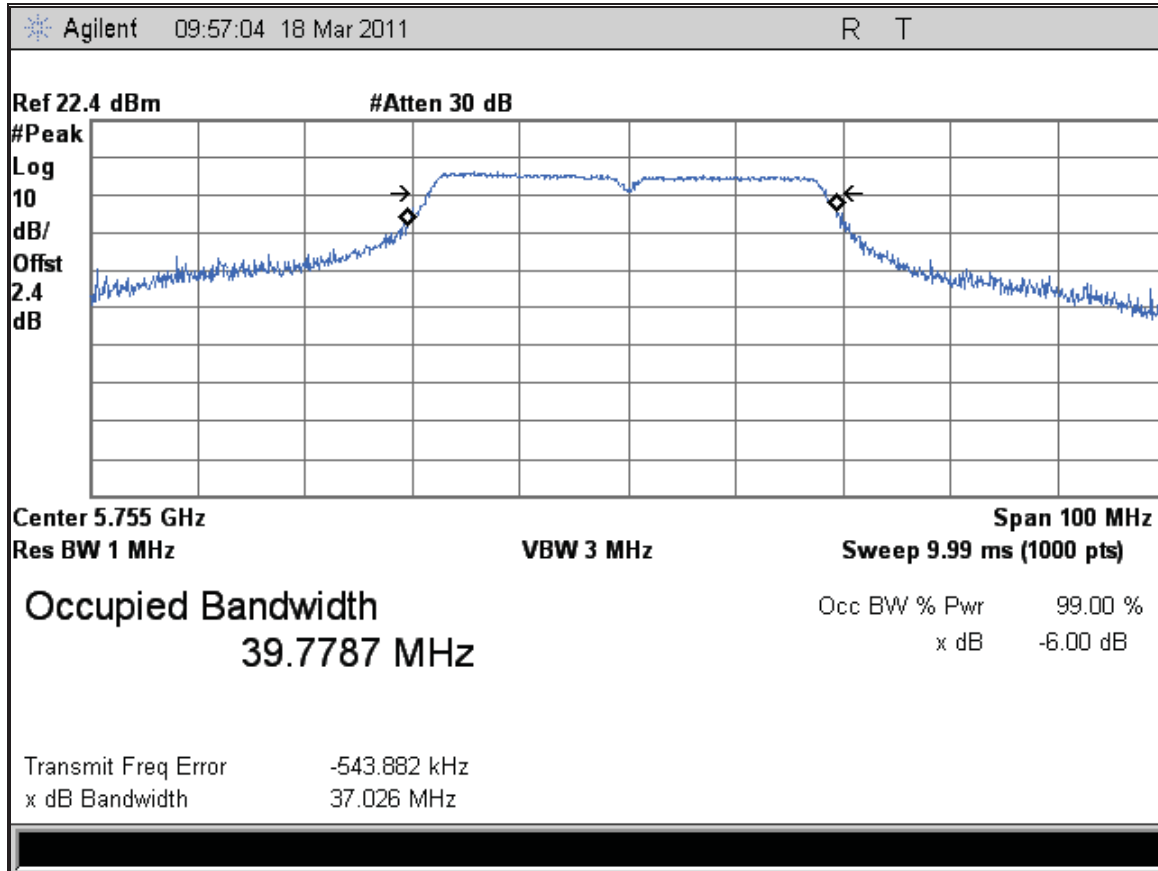

Figure 442: Occupied Bandwidth at 802.11n HT40, 5755MHz - Chain 0 (13.5Mbps)

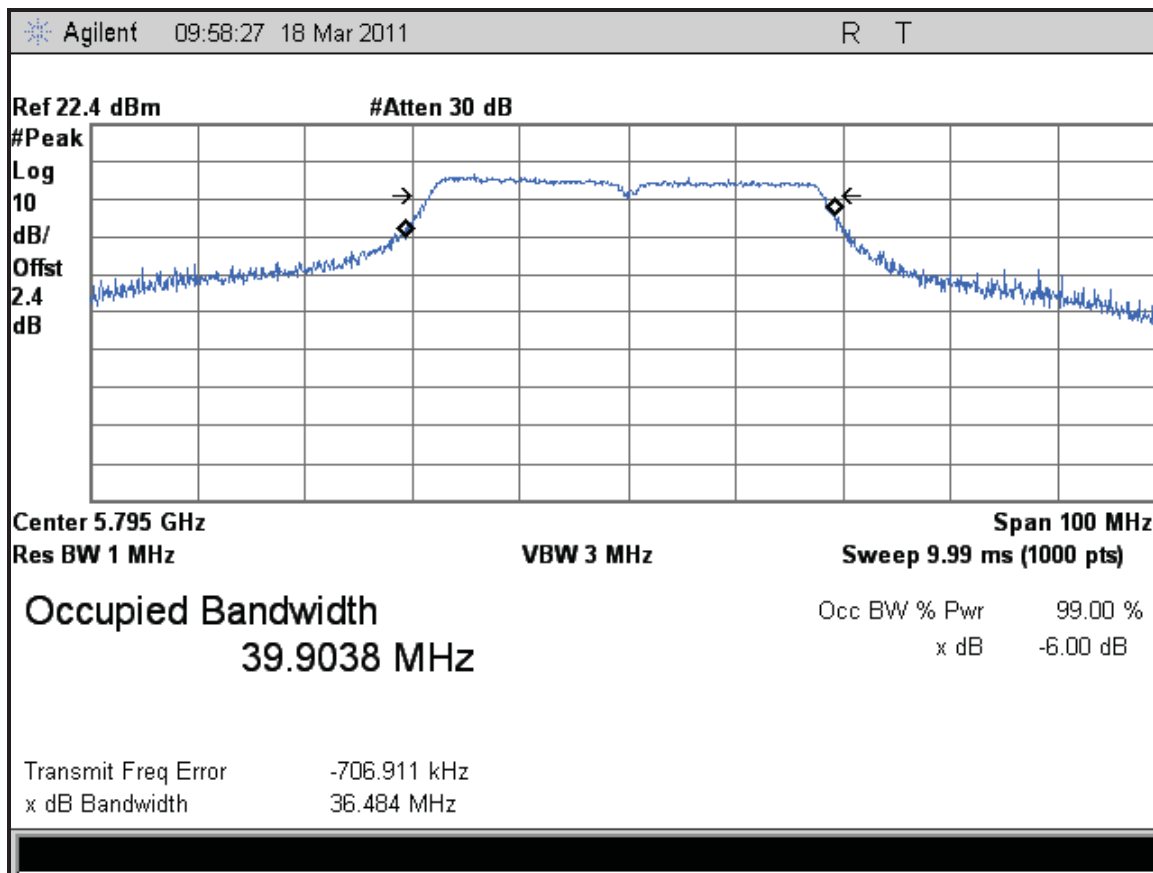

Figure 443: Occupied Bandwidth at 802.11n HT40, 5795MHz - Chain 1 (13.5Mbps)

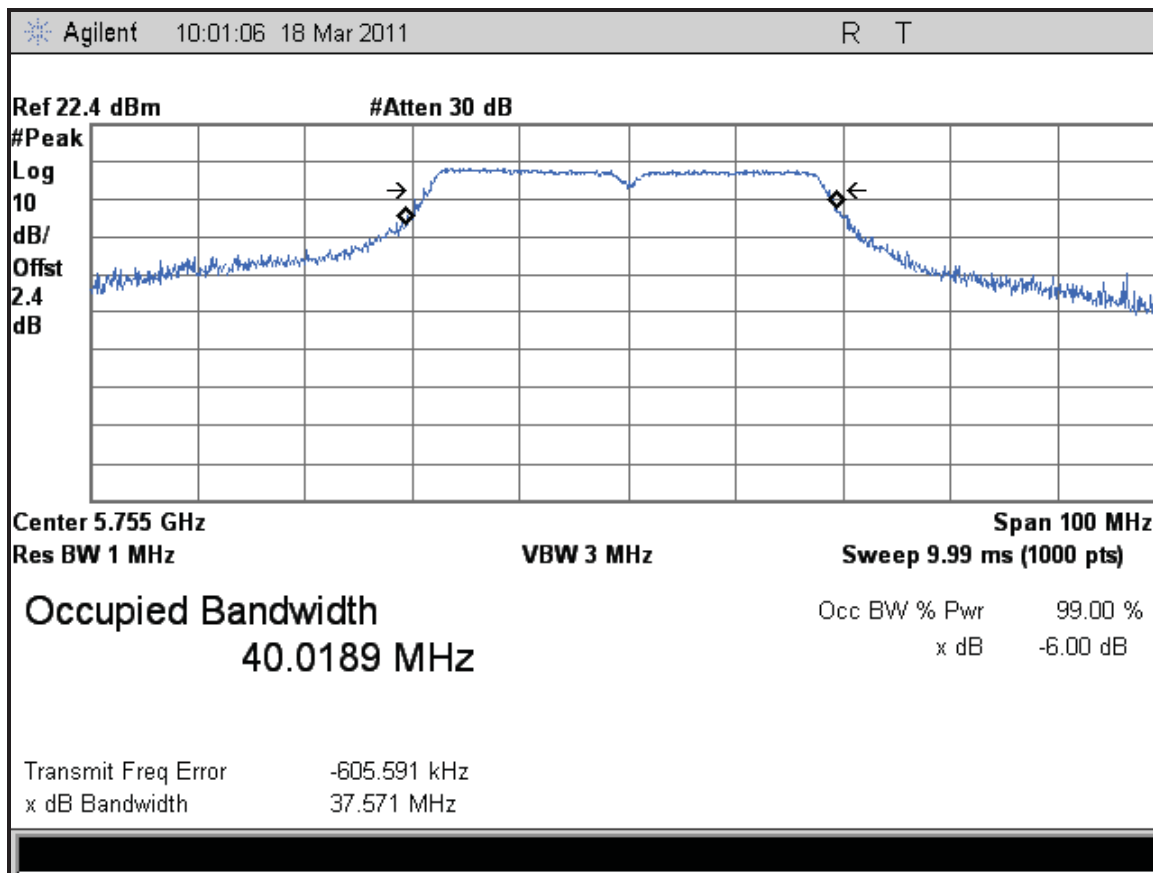

Figure 444: Occupied Bandwidth at 802.11n HT40, 5755MHz - Chain 2 (13.5Mbps)

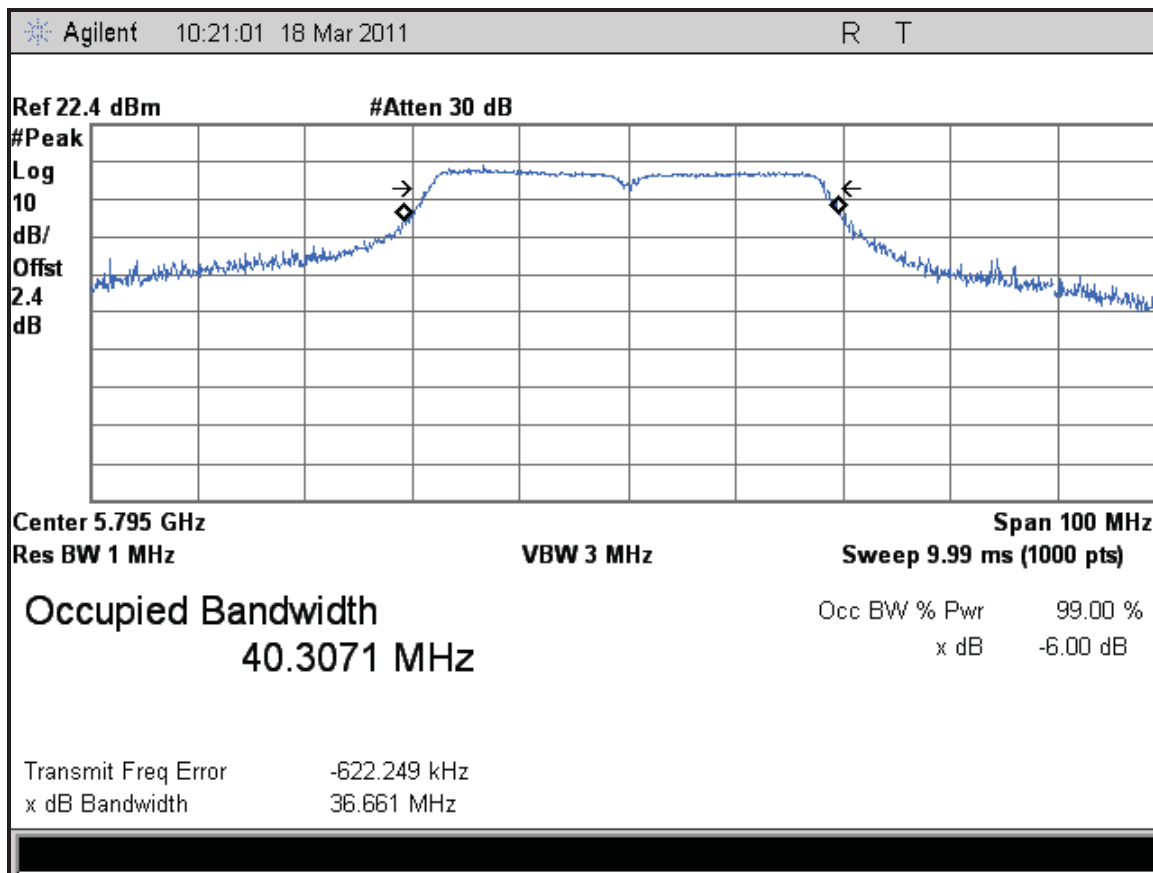

Figure 445: Occupied Bandwidth at 802.11n HT40, 5795MHz - Chain 2 (13.5Mbps)

5.3 Band-edge Requirements

The setup was identical to RF output power measurement. Intentional radiators operating under the alternative provisions to the general emission limits, must be designed to ensure that the 20 dB bandwidth of the emission, or whatever bandwidth may otherwise be specified in the specific rule section under which the equipment operates, is contained within the frequency band designated in the rule section under which the equipment is operated. The requirement to contain the designated bandwidth of the emission within the specified frequency band includes the effects from frequency sweeping, frequency hopping and other modulation techniques that may be employed as well as the frequency stability of the transmitter over expected variations in temperature and supply voltage. If the frequency stability is not specified in the regulations, it is recommended that the fundamental emission be kept within at least the central 80% of the permitted band in order to minimize the possibility of out-of-band operation.

Any frequency outside the band of 2400 MHz to 2483.5MHz, the power output level must be below 20 dB from the in-band transmitting signal; CFR 47 Part 15.215, 15.247(d) and RSS 210 A8.5

5.3.1 Results

The Out of band emission was conducted on the conducted test Sample.

As originally tested, the EUT was found to be compliant to the requirements of the test standard(s).

Table 11: Band-Edge Requirements – Test Results

Test Conditions: Conducted Measurement, Normal Temperature and Voltage only								
Antenna Type: Integrated				Power Setting: See test plan				
Max. Antenna Gain: + 3.2 dBi				Signal State: Modulated				
Ambient Temp.: 21° C				Relative Humidity: 39%				
-20 dB _r Band-Edge Results								
Operating Freq.	Mode	Chain 0		Chain 1		Chain 2		Result
		Level (dBm)	Limit (dBm)	Level (dBm)	Limit (dBm)	Level (dBm)	Limit (dBm)	
5745 MHz	24Mbps	-28.45	-18.39	-29.85	17.51	-25.80	-15.20	Pass
5785 MHz	24Mbps	-46.54	-18.55	-45.69	-16.05	-45.12	-15.35	Pass
5825 MHz	24Mbps	-37.28	-18.34	-37.01	-18.04	-33.76	-14.87	Pass
5745 MHz	6.5Mbps	-25.37	-18.32	-25.17	-17.92	-23.84	-16.59	Pass
5785 MHz	6.5Mbps	-46.49	-18.22	-45.54	-17.18	-45.41	-15.67	Pass
5825 MHz	6.5Mbps	-31.88	-18.58	-32.60	-17.09	-31.36	-16.33	Pass
5755 MHz	HT40 13.5 Mbps	-26.18	-21.66	-29.55	-23.03	-24.95	-20.41	Pass
5795 MHz	HT40 13.5 Mbps	-41.83	-21.23	-41.88	-23.16	-37.79	-20.05	Pass
Note: The stated limits for 20 dB _r are relative to each individual output per KDB 662911 Method.								

Table 12: Out of band Conducted Emission – Test Results

Test Conditions: Conducted Measurement, Normal Temperature and Voltage only								
Antenna Type: Integrated				Power Setting: See test plan				
Max. Antenna Gain: + 3.2 dBi				Signal State: Modulated				
Ambient Temp.: 21° C				Relative Humidity: 39%				
Output of Band Results								
Operating Freq.	Mode	30 MHz to 25 GHz						Result
		Chain 0		Chain 1		Chain 2		
5745 MHz	24Mbps	Fig.	447/448	Fig.	456/457	Fig.	465/466	Pass
5785 MHz	24Mbps	Fig.	450/451	Fig.	459/460	Fig.	468/469	Pass
5825 MHz	24Mbps	Fig.	453/454	Fig.	462/463	Fig.	471/472	Pass
5745 MHz	6.5Mbps	Fig.	474/475	Fig.	483/484	Fig.	492/493	Pass
5785 MHz	6.5Mbps	Fig.	477/478	Fig.	486/487	Fig.	495/496	Pass
5825 MHz	6.5Mbps	Fig.	480/481	Fig.	489/490	Fig.	498/499	Pass
5755 MHz	HT40 13.5 Mbps	Fig.	501/502	Fig.	507/508	Fig.	513/514	Pass
5795 MHz	HT40 13.5 Mbps	Fig.	504/505	Fig.	510/511	Fig.	516/517	Pass
Note: All Out of Band Emissions are compared to the relative 20 dBr limit of that output, per KDB 662911.								

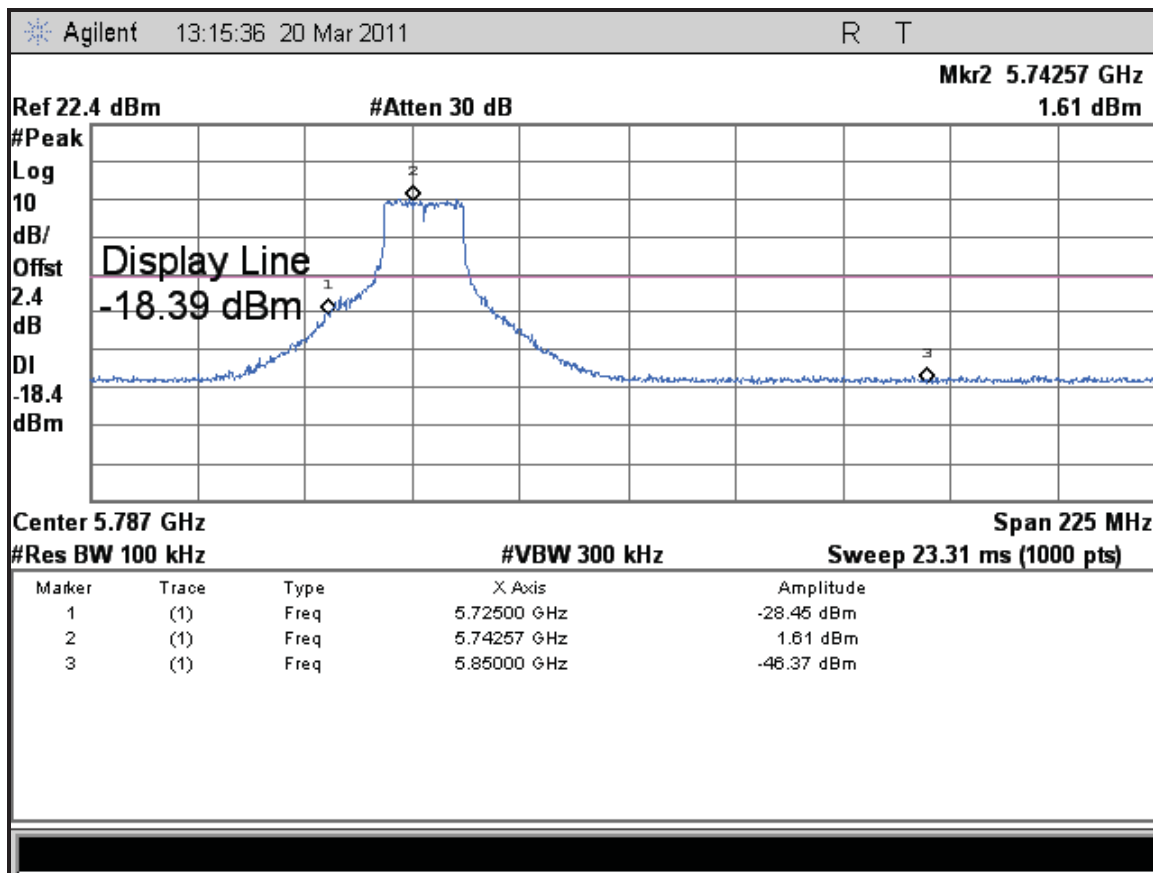
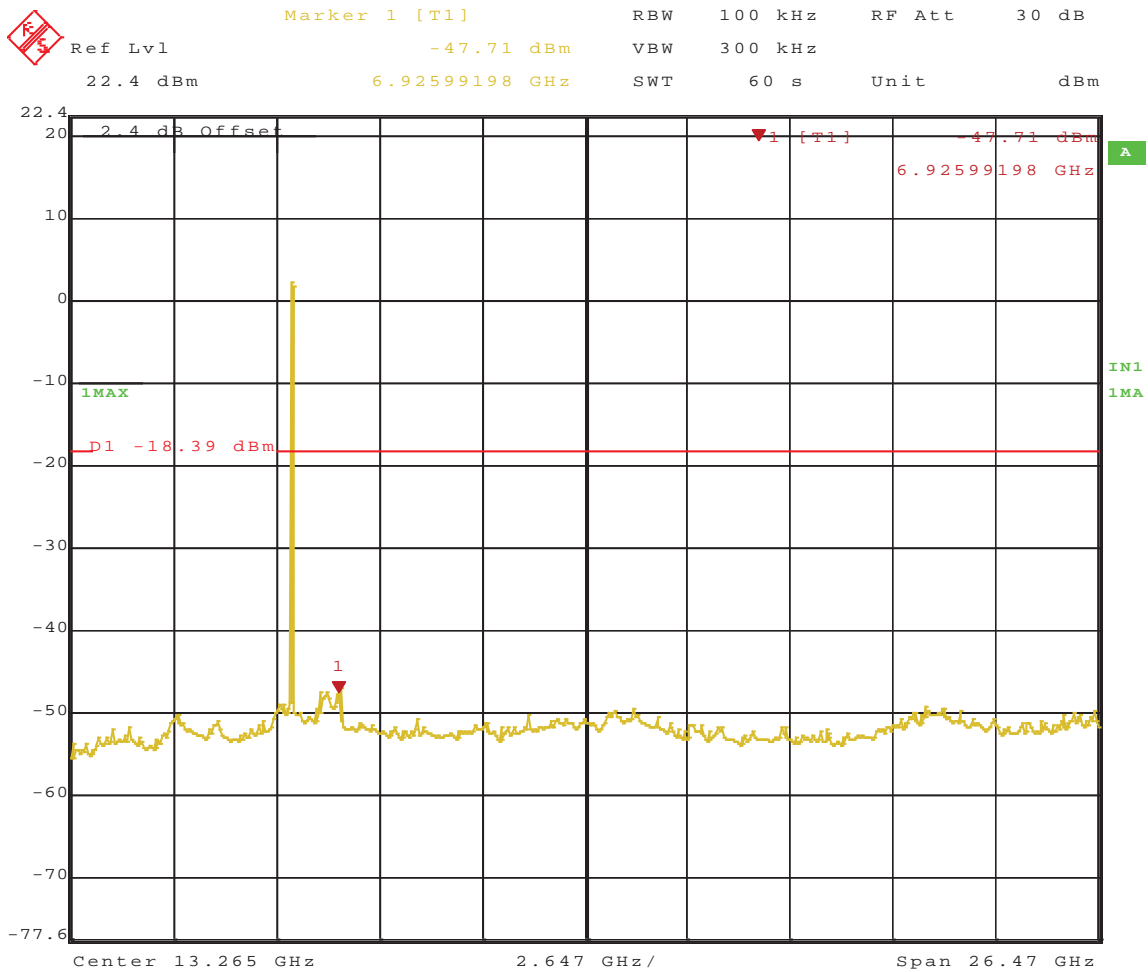
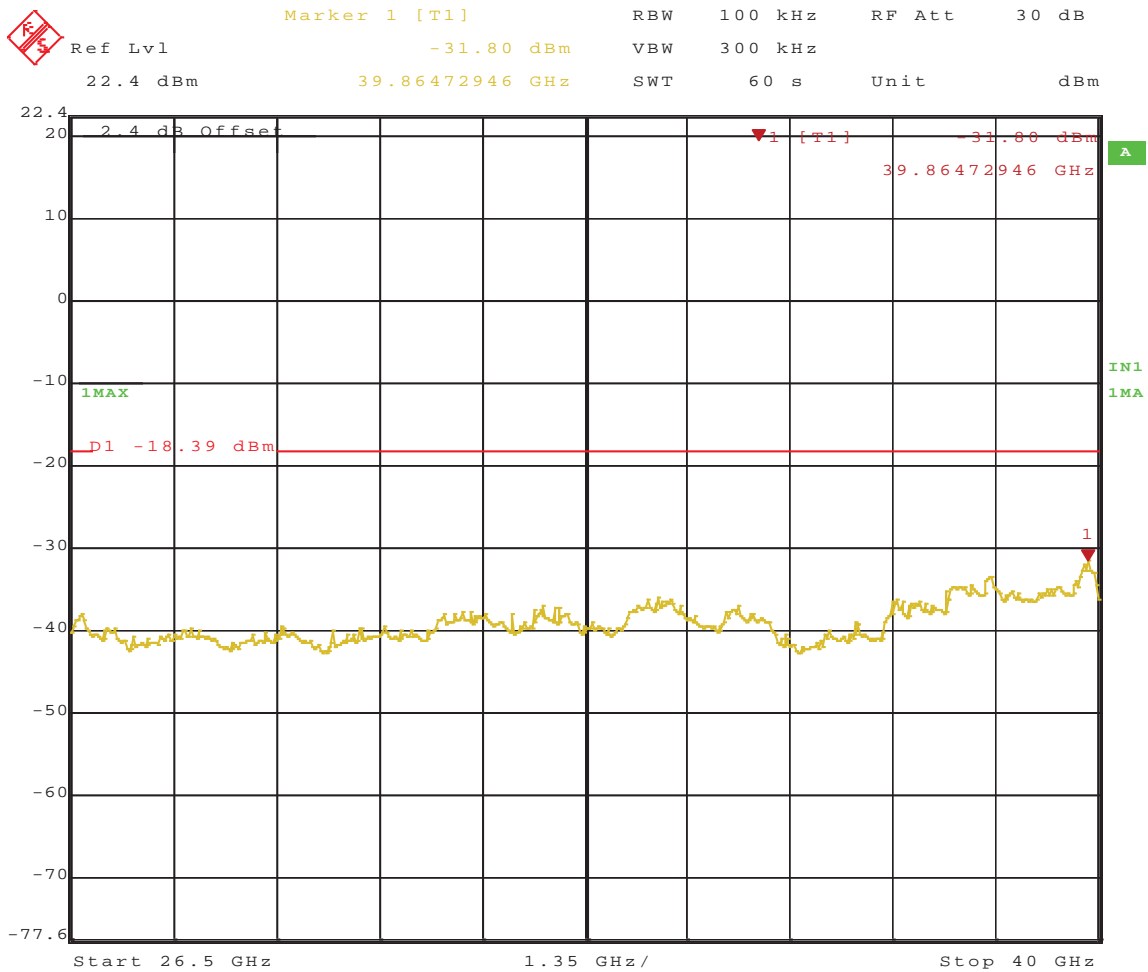

Figure 446: Band-edge Requirement at 802.11a, 24 Mbps 5745 MHz, Chain 0 – Plot 1



Date: 22.MAR.2011 13:39:32

Figure 447: Out of Band at 802.11a, 24 Mbps 5745 MHz, Chain 0 – Plot 2



Date: 22.MAR.2011 13:43:01

Figure 448: Out of Band at 802.11a, 24 Mbps 5745 MHz, Chain 0 – Plot 3

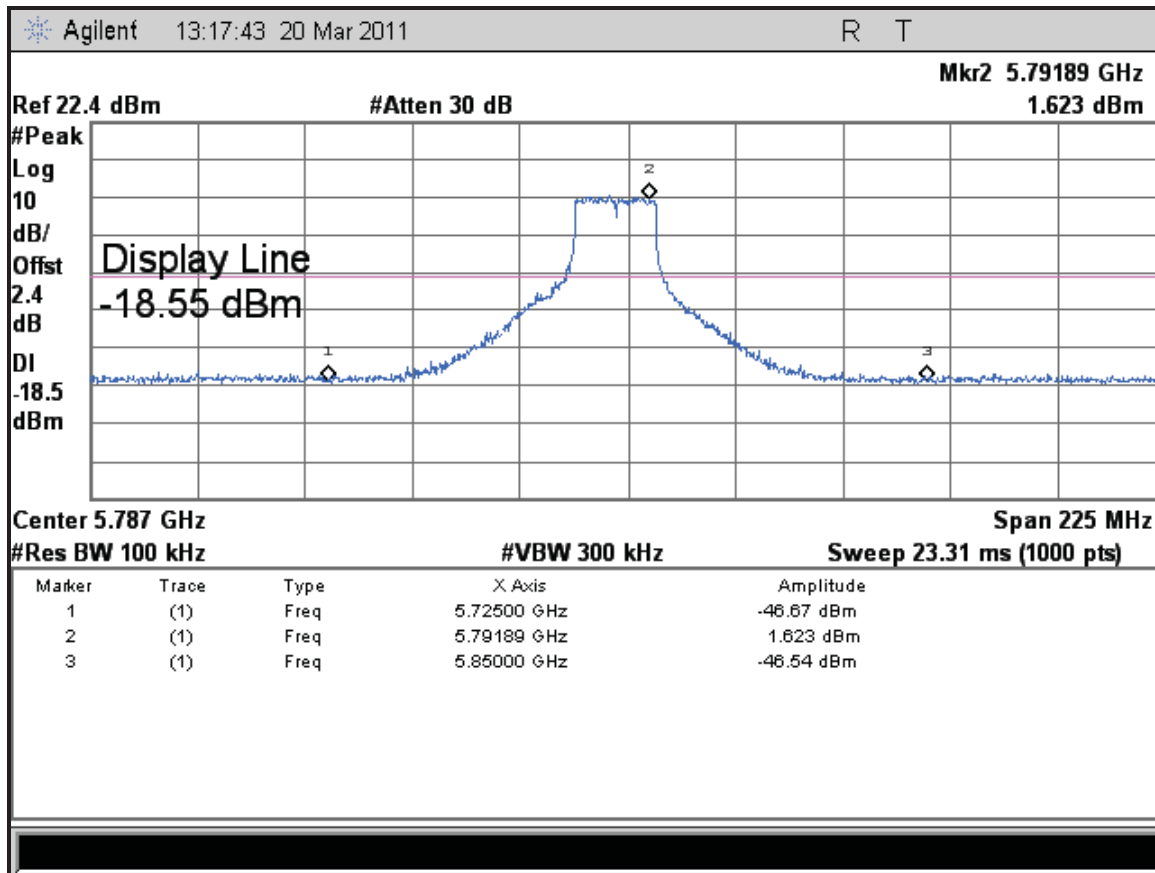
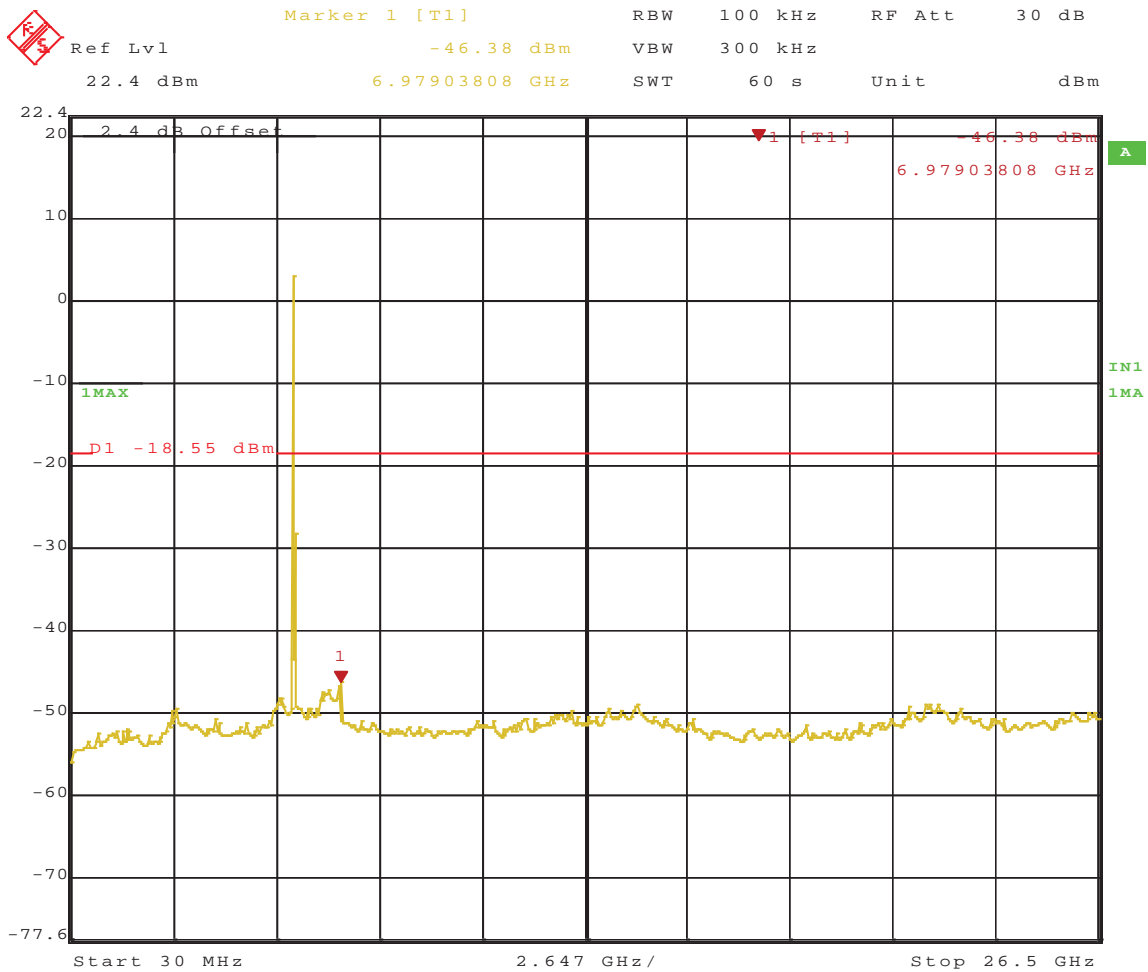

Figure 449: Band-edge Requirement at 802.11a, 24 Mbps 5785 MHz, Chain 0 – Plot 1



Date: 22.MAR.2011 13:52:31

Figure 450: Out of Band at 802.11a, 24 Mbps 5785 MHz, Chain 0 – Plot 2

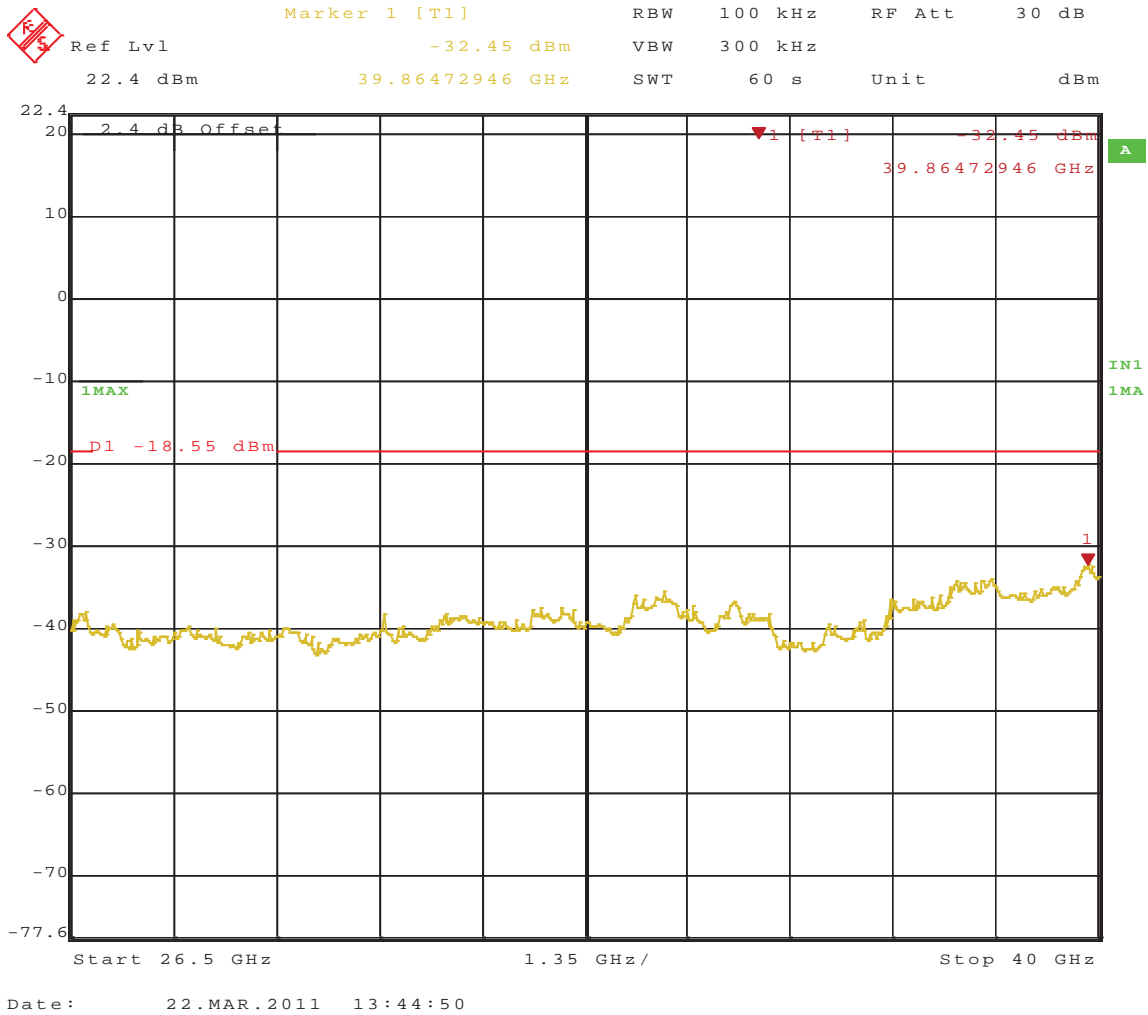

Figure 451: Out of Band at 802.11a, 24 Mbps 5785 MHz, Chain 0 – Plot 3

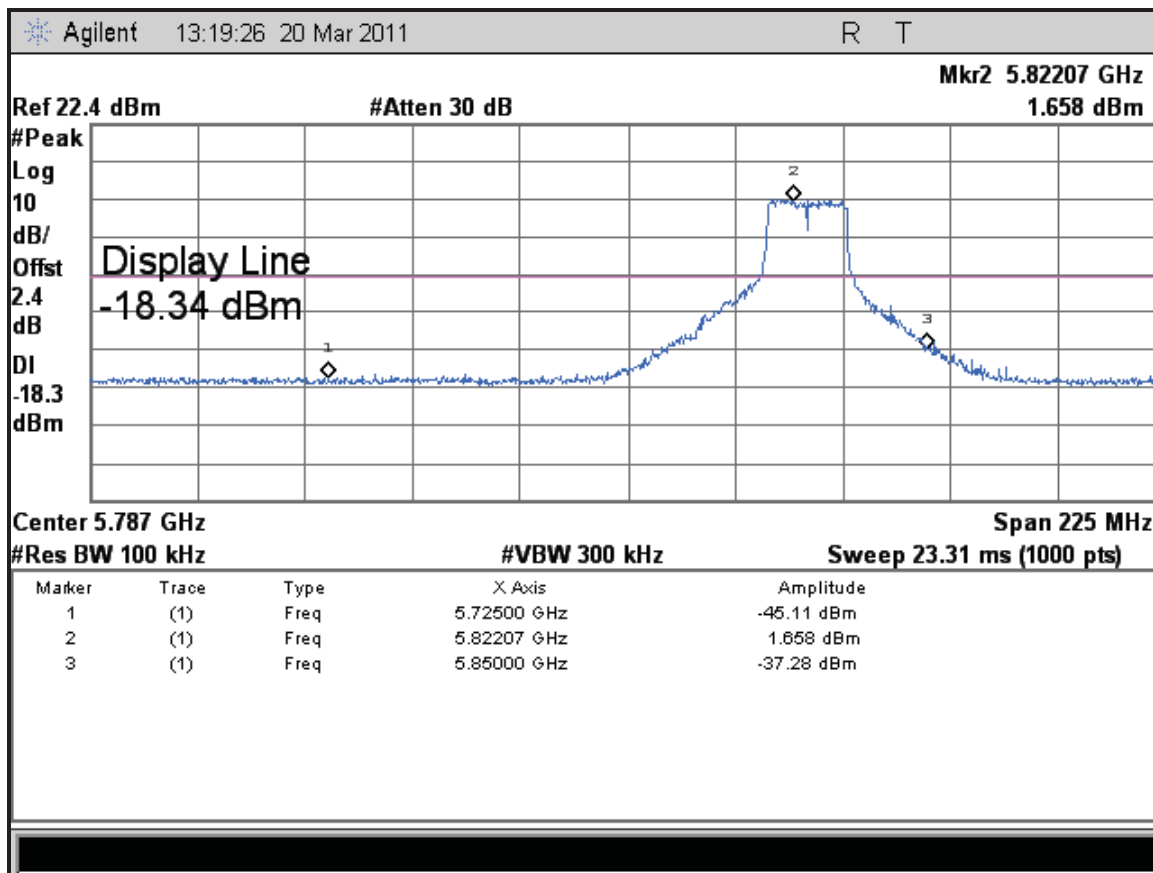
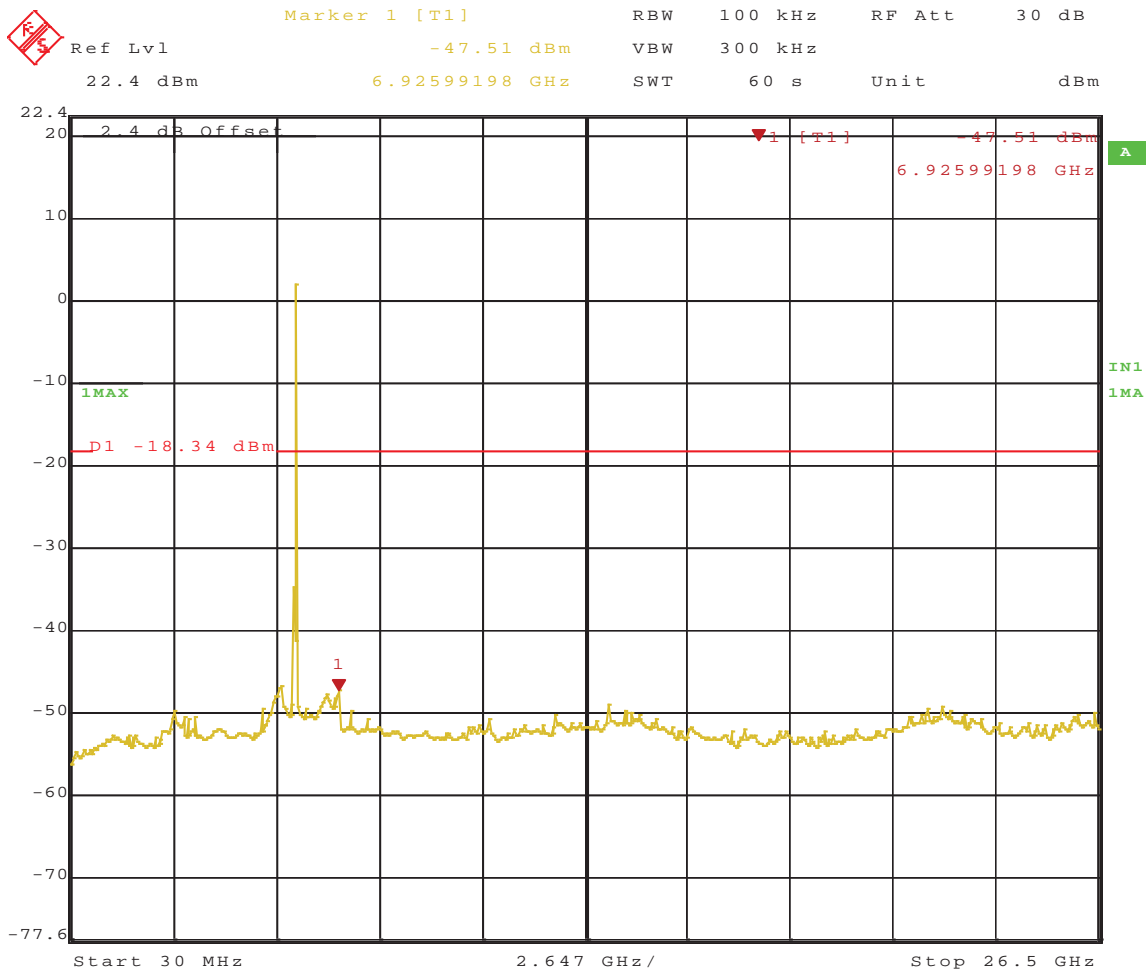
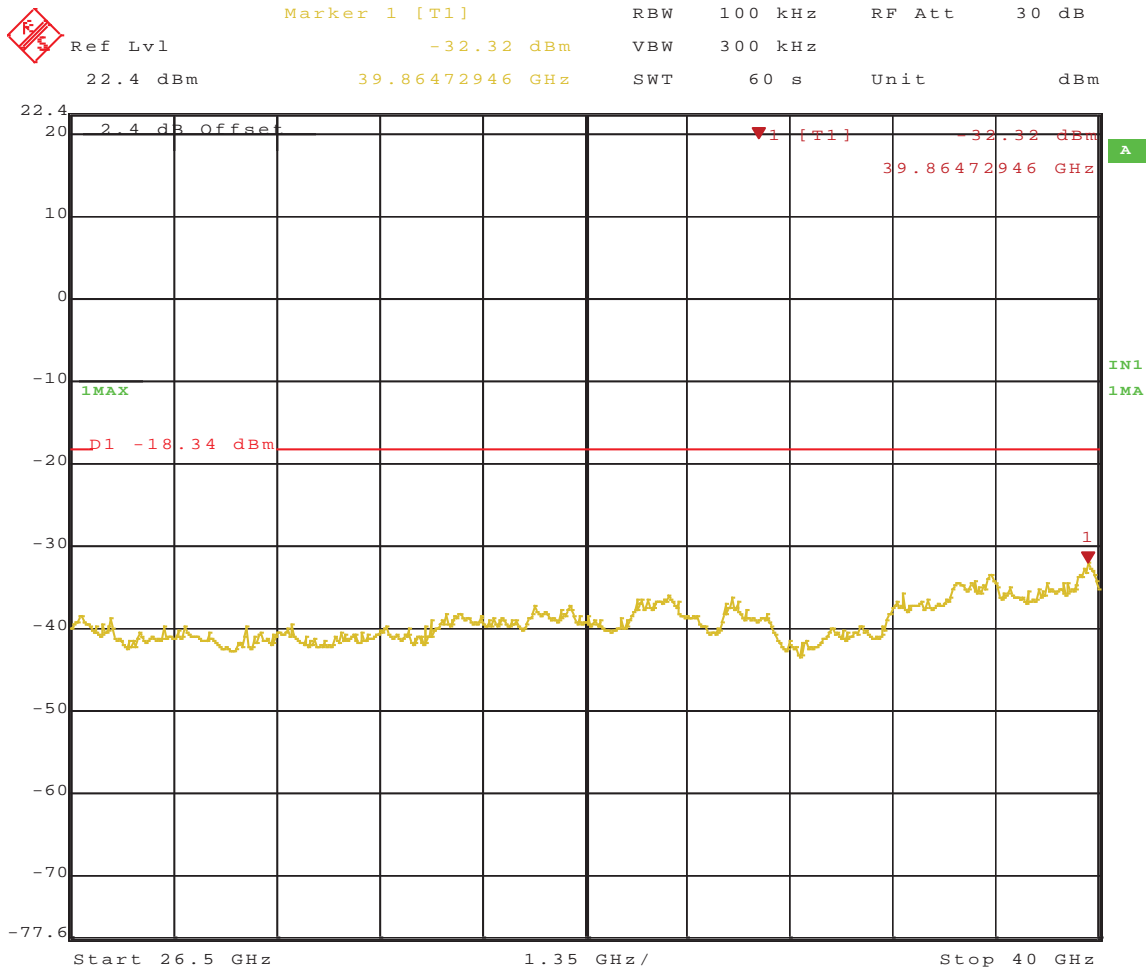

Figure 452: Band-edge Requirement at 802.11a, 24 Mbps 5825 MHz, Chain 0 – Plot 1



Date: 22.MAR.2011 13:57:18

Figure 453: Out of Band at 802.11a, 24 Mbps 5825 MHz, Chain 0 – Plot 2



Date: 22.MAR.2011 13:58:50

Figure 454: Out of Band at 802.11a, 24 Mbps 5825 MHz, Chain 0 – Plot 3

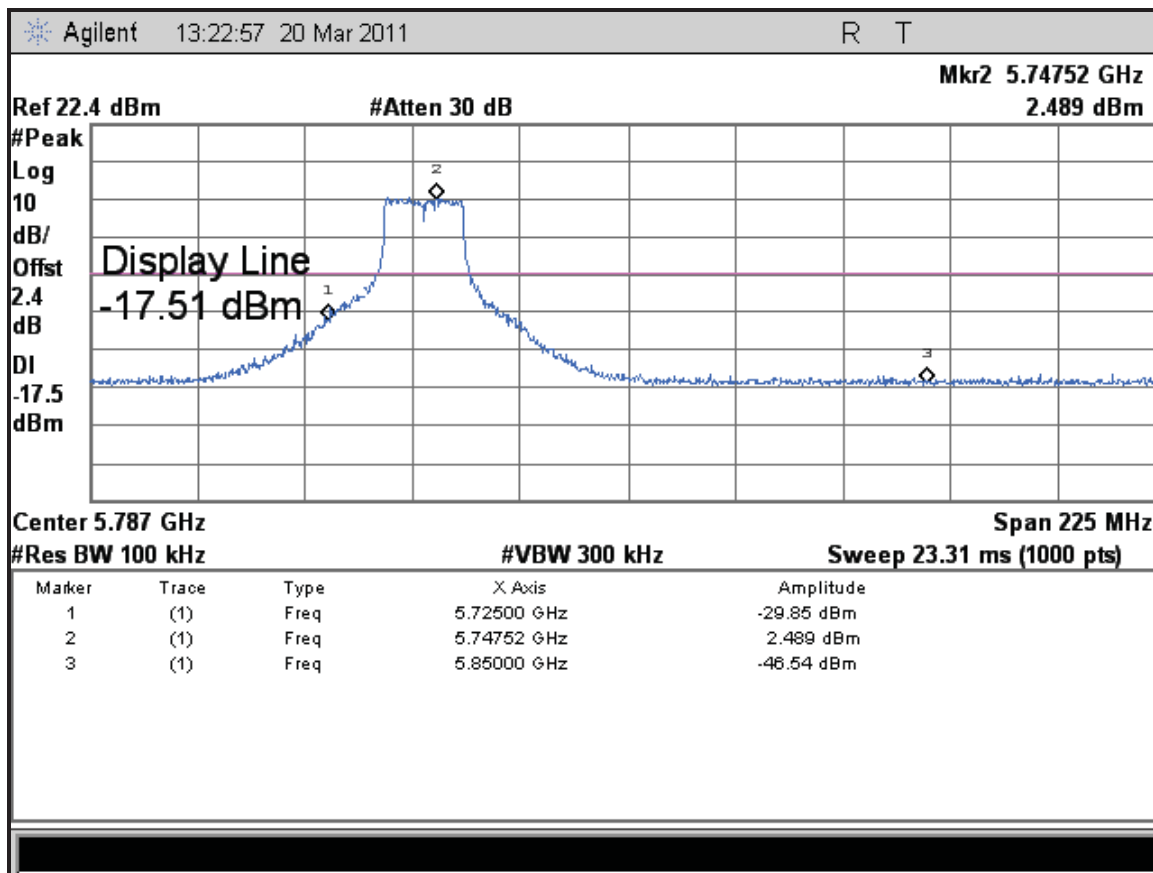
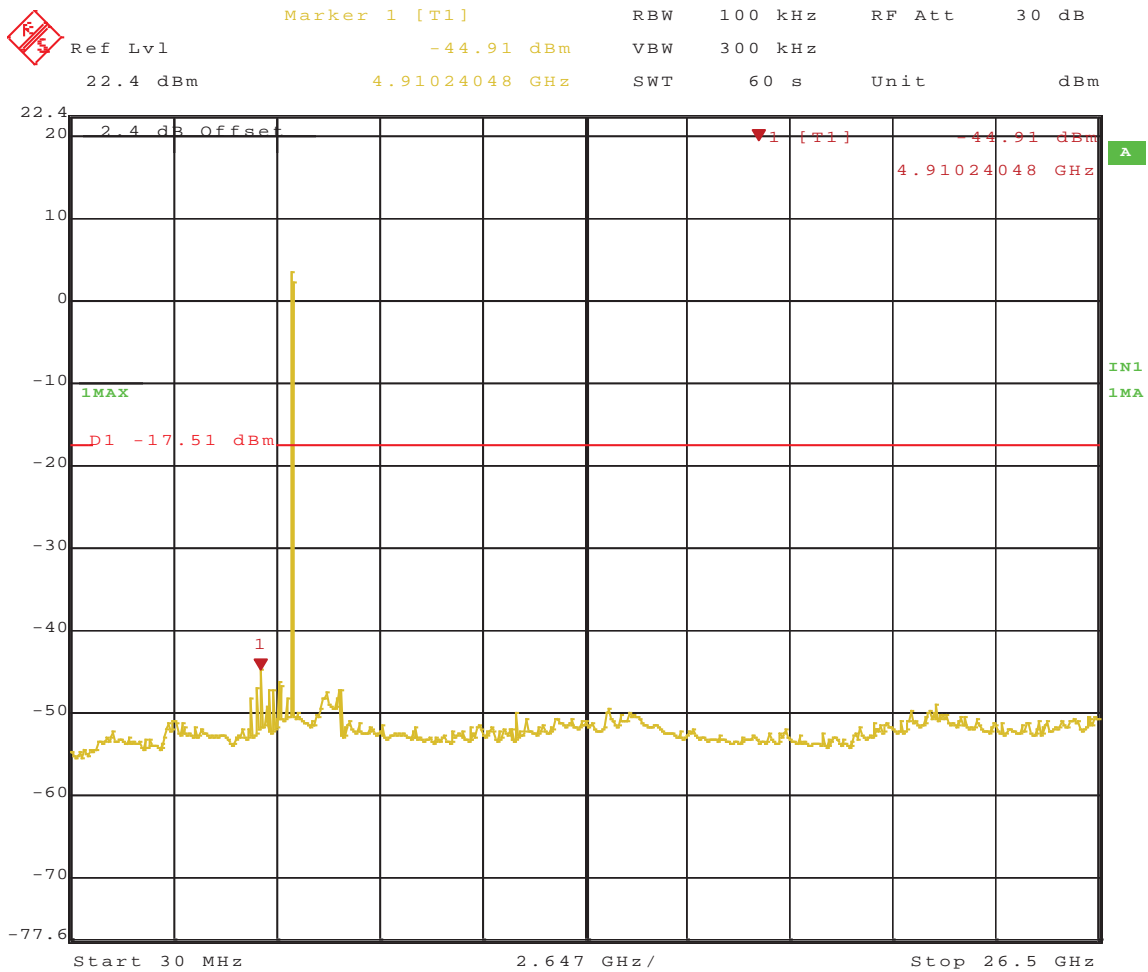
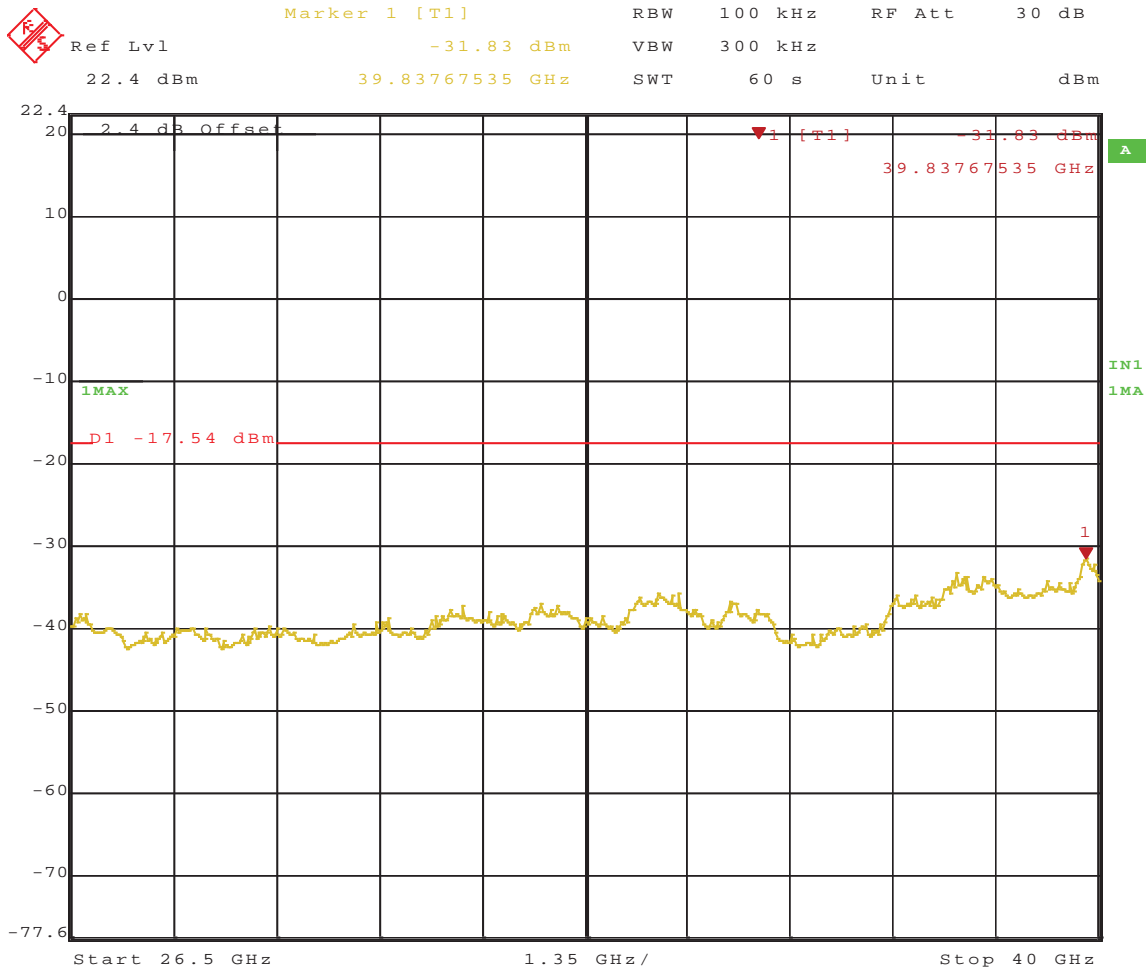

Figure 455: Band-edge Requirement at 802.11a, 24 Mbps 5745 MHz, Chain 1 – Plot 1



Date: 22.MAR.2011 14:04:40

Figure 456: Out of Band at 802.11a, 24 Mbps 5745 MHz, Chain 1 – Plot 2



Date: 22.MAR.2011 14:03:00

Figure 457: Out of Band at 802.11a, 24 Mbps 5745 MHz, Chain 1 – Plot 3

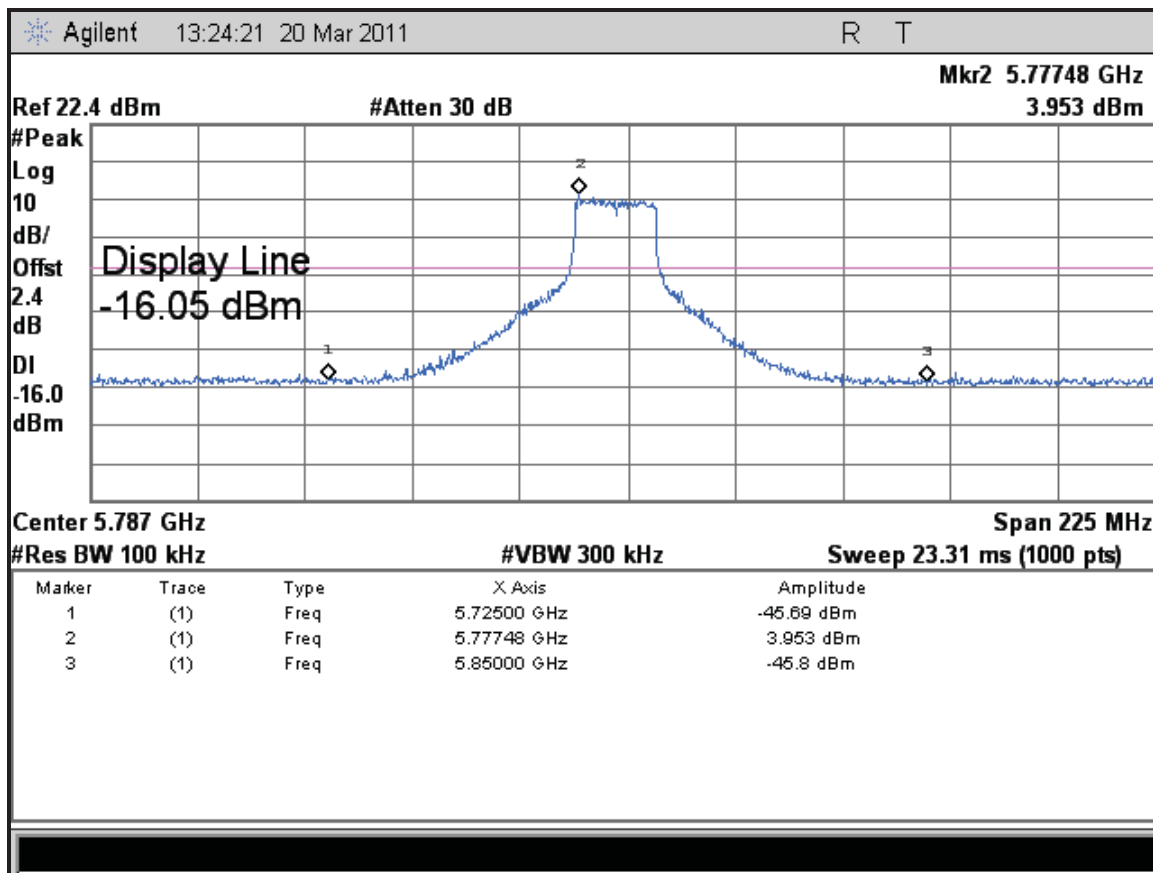
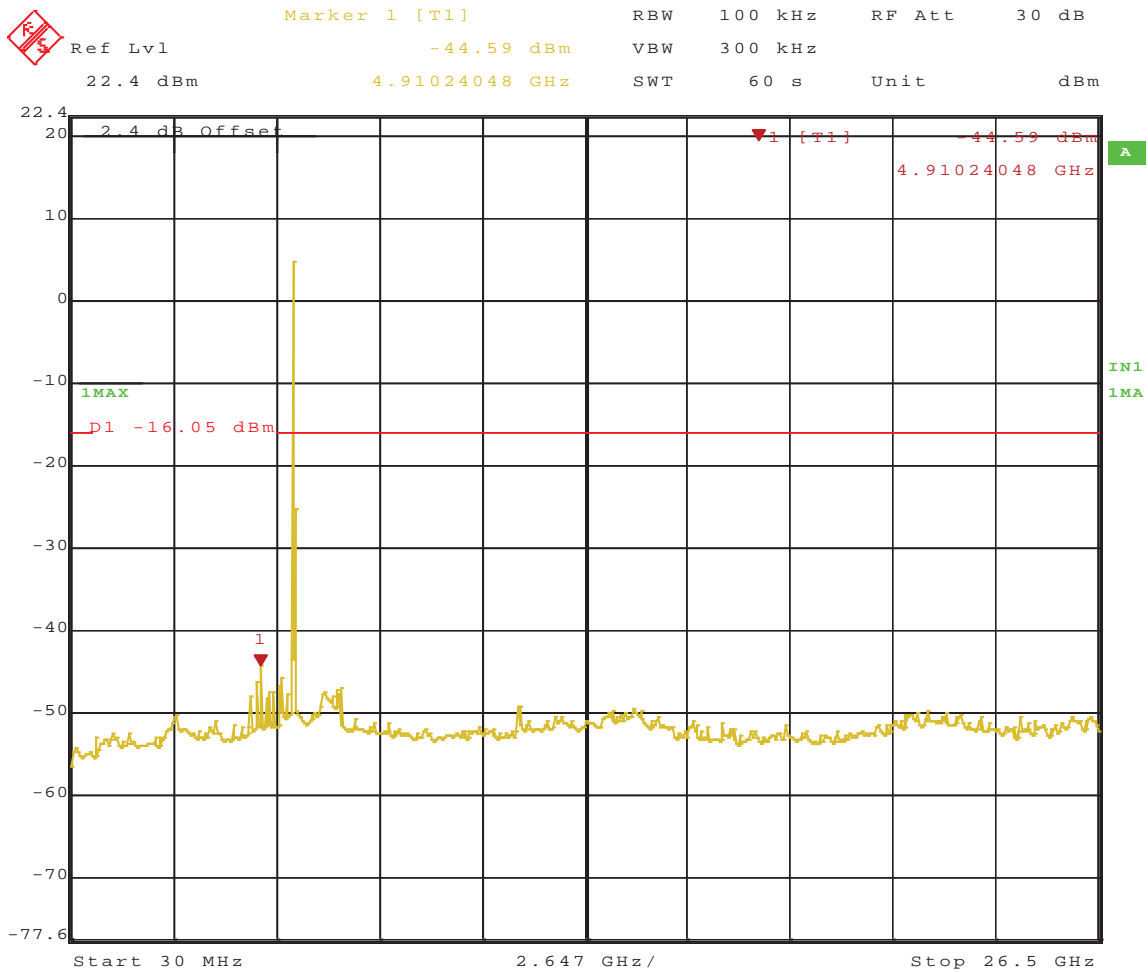
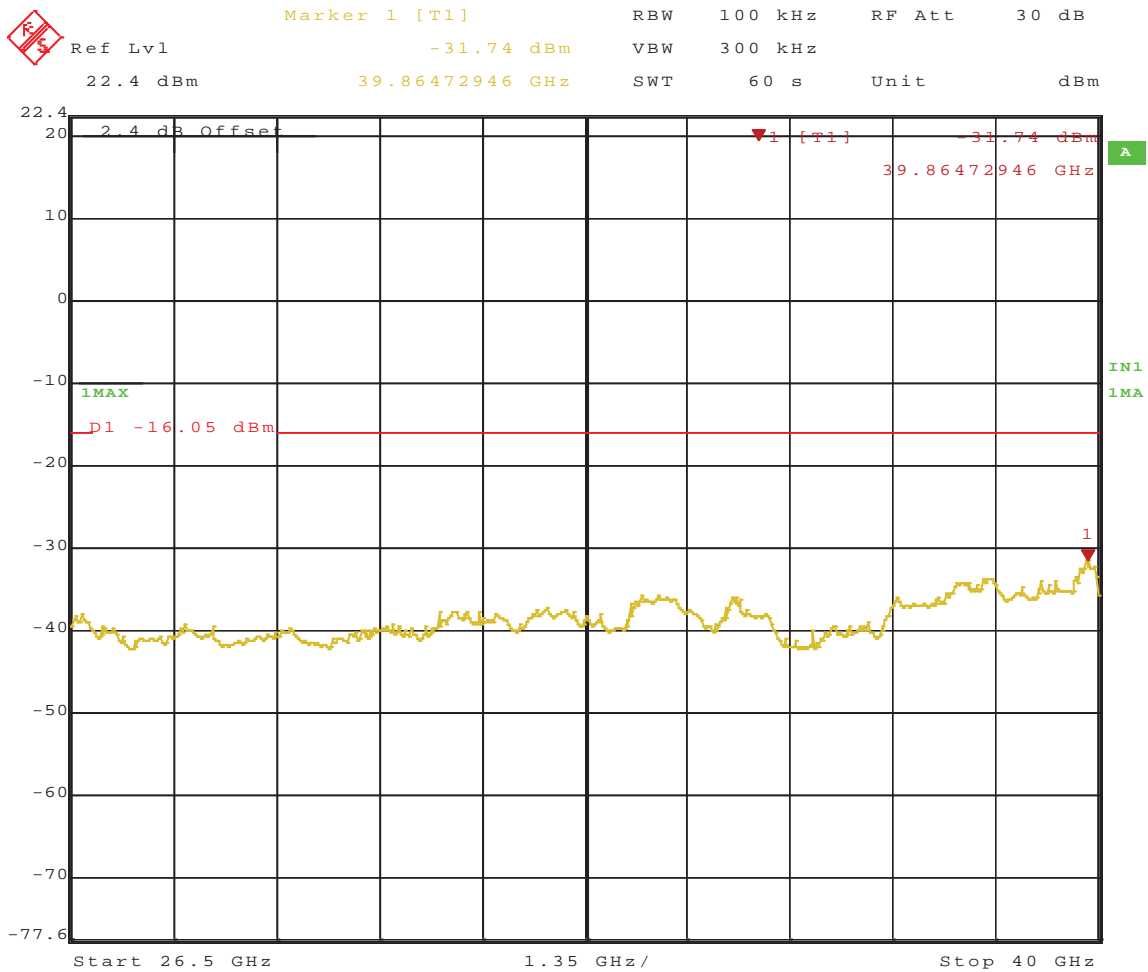

Figure 458: Band-edge Requirement at 802.11a, 24 Mbps 5785 MHz, Chain 1 – Plot 1



Date: 22.MAR.2011 14:06:55

Figure 459: Out of Band at 802.11a, 24 Mbps 5785 MHz, Chain 1 – Plot 2



Date: 22.MAR.2011 14:11:41

Figure 460: Out of Band at 802.11a, 24 Mbps 5785 MHz, Chain 1 – Plot 3

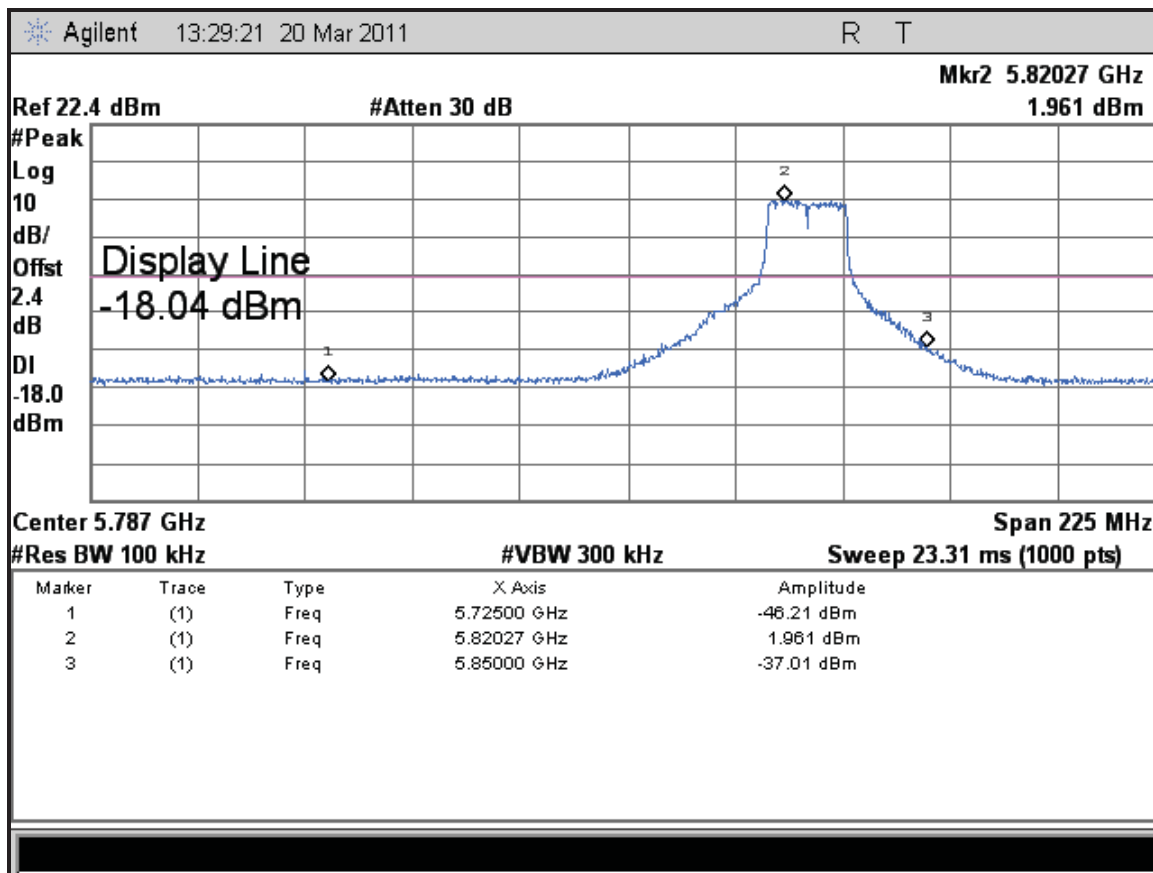
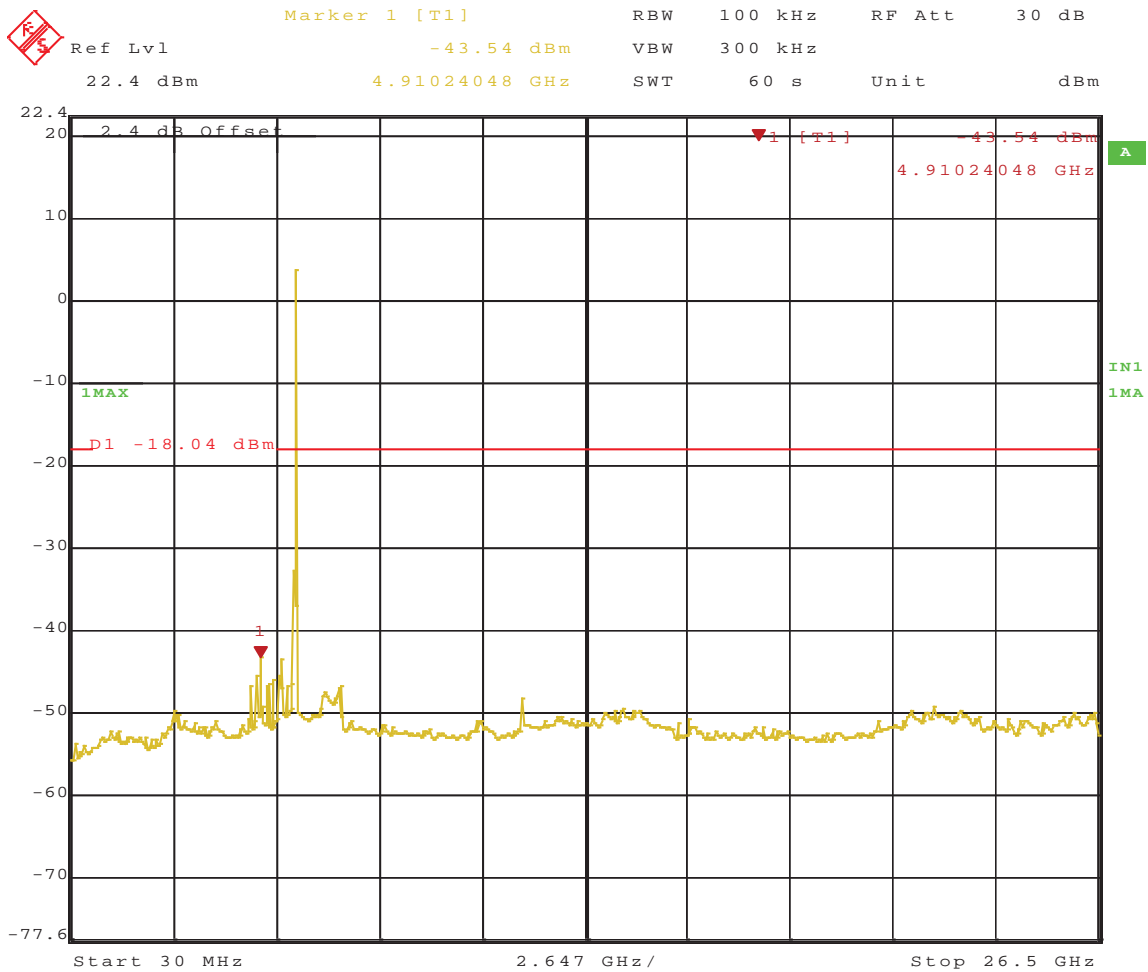
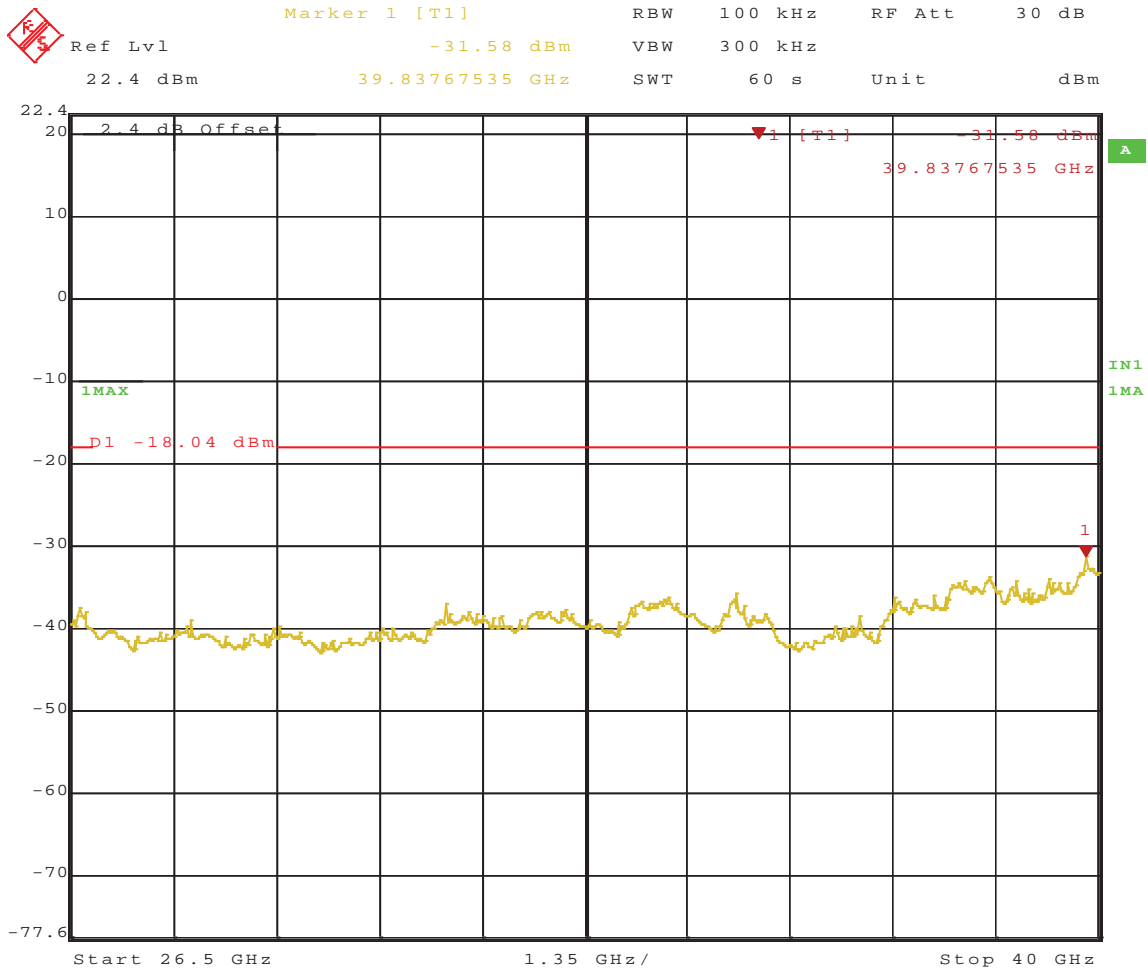

Figure 461: Band-edge Requirement at 802.11a, 24 Mbps 5825 MHz, Chain 1 – Plot 1



Date: 22.MAR.2011 14:17:34

Figure 462: Out of Band at 802.11a, 24 Mbps 5825 MHz, Chain 1 – Plot 2



Date: 22.MAR.2011 14:13:26

Figure 463: Out of Band at 802.11a, 24 Mbps 5825 MHz, Chain 1 – Plot 3

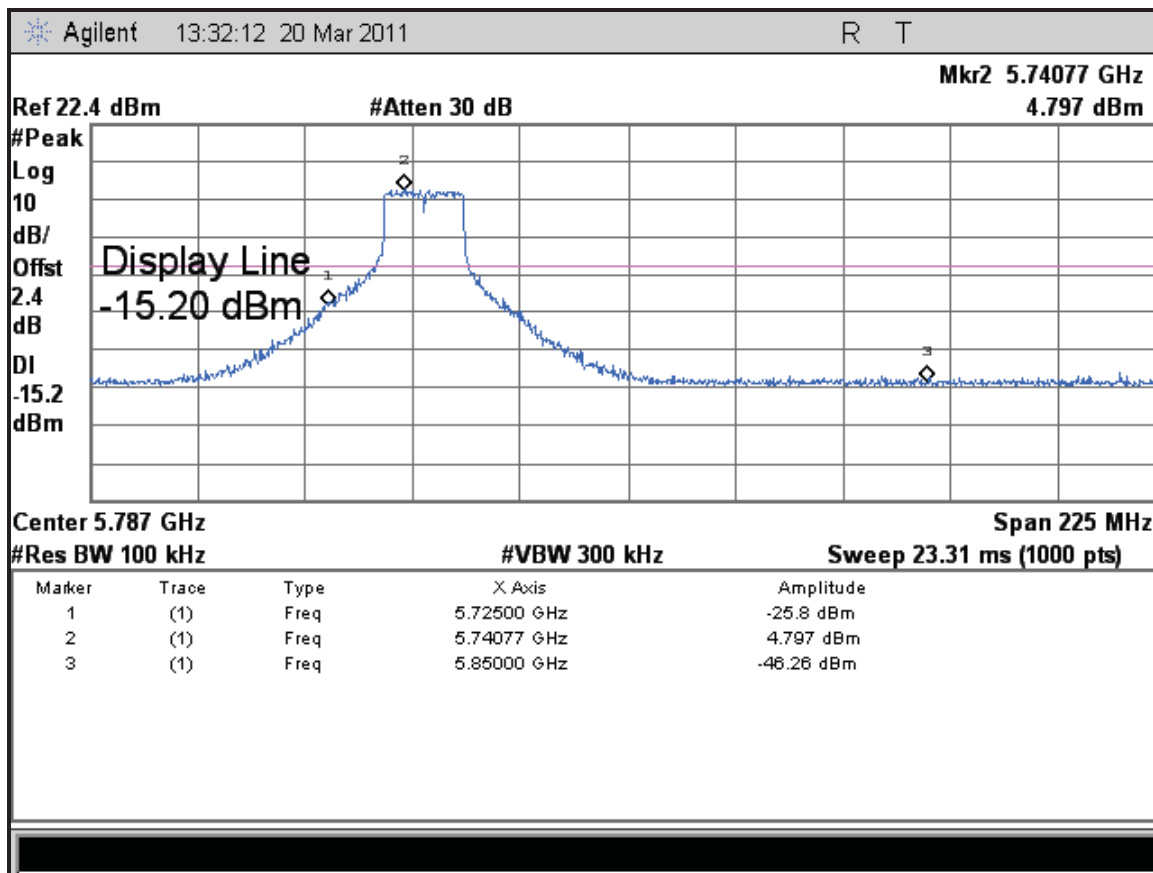
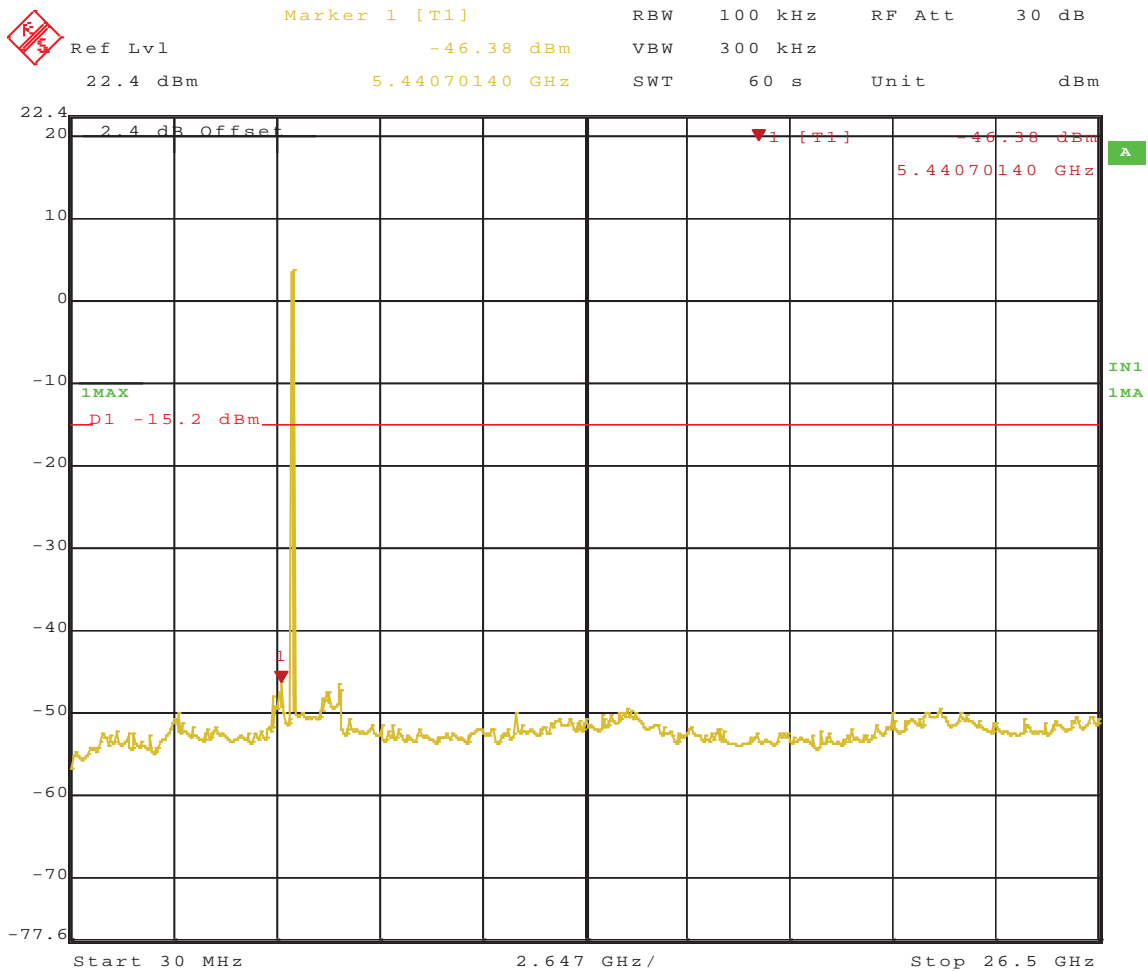
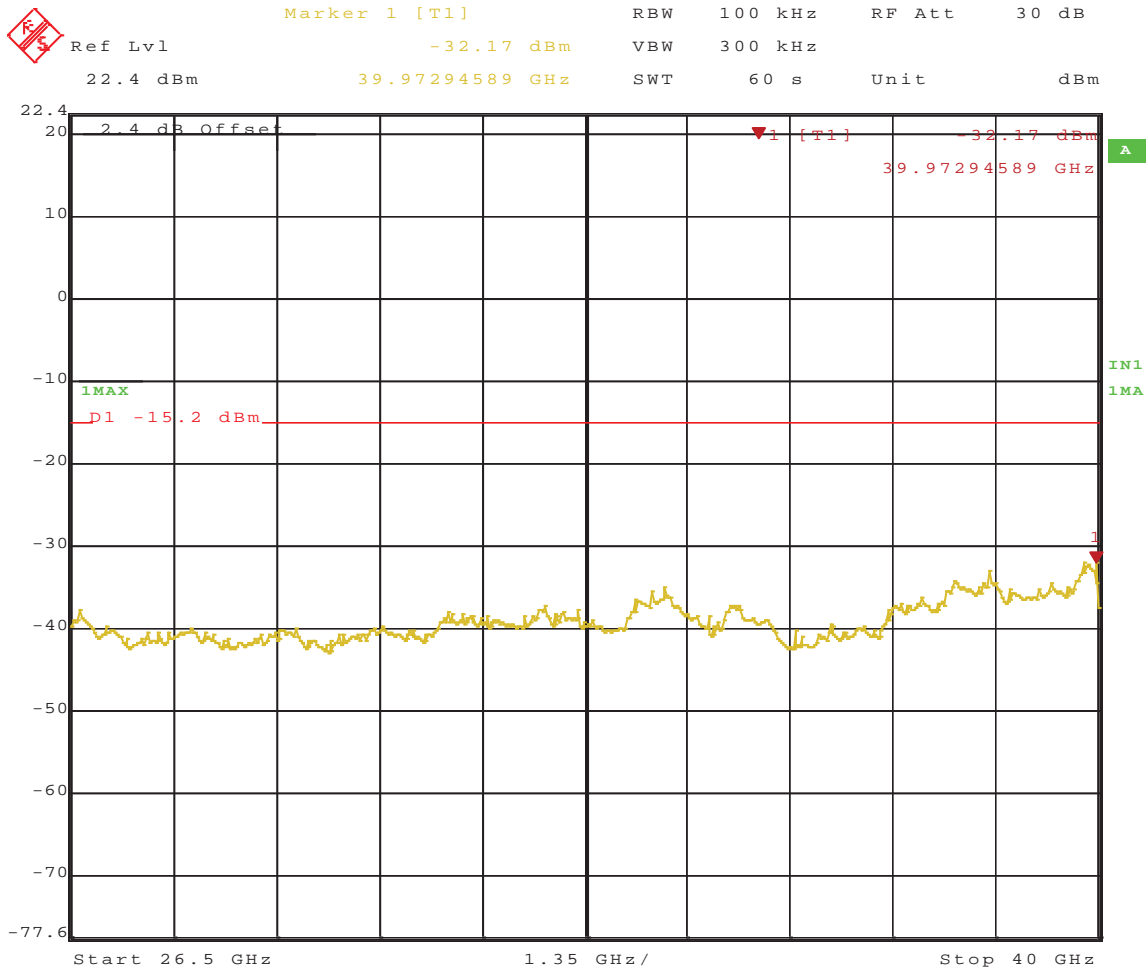

Figure 464: Band-edge Requirement at 802.11a, 24 Mbps 5745 MHz, Chain 2 – Plot 1



Date: 22.MAR.2011 14:21:01

Figure 465: Out of Band at 802.11a, 24 Mbps 5745 MHz, Chain 2 – Plot 2



Date: 22.MAR.2011 14:22:31

Figure 466: Out of Band at 802.11a, 24 Mbps 5745 MHz, Chain 2 – Plot 3

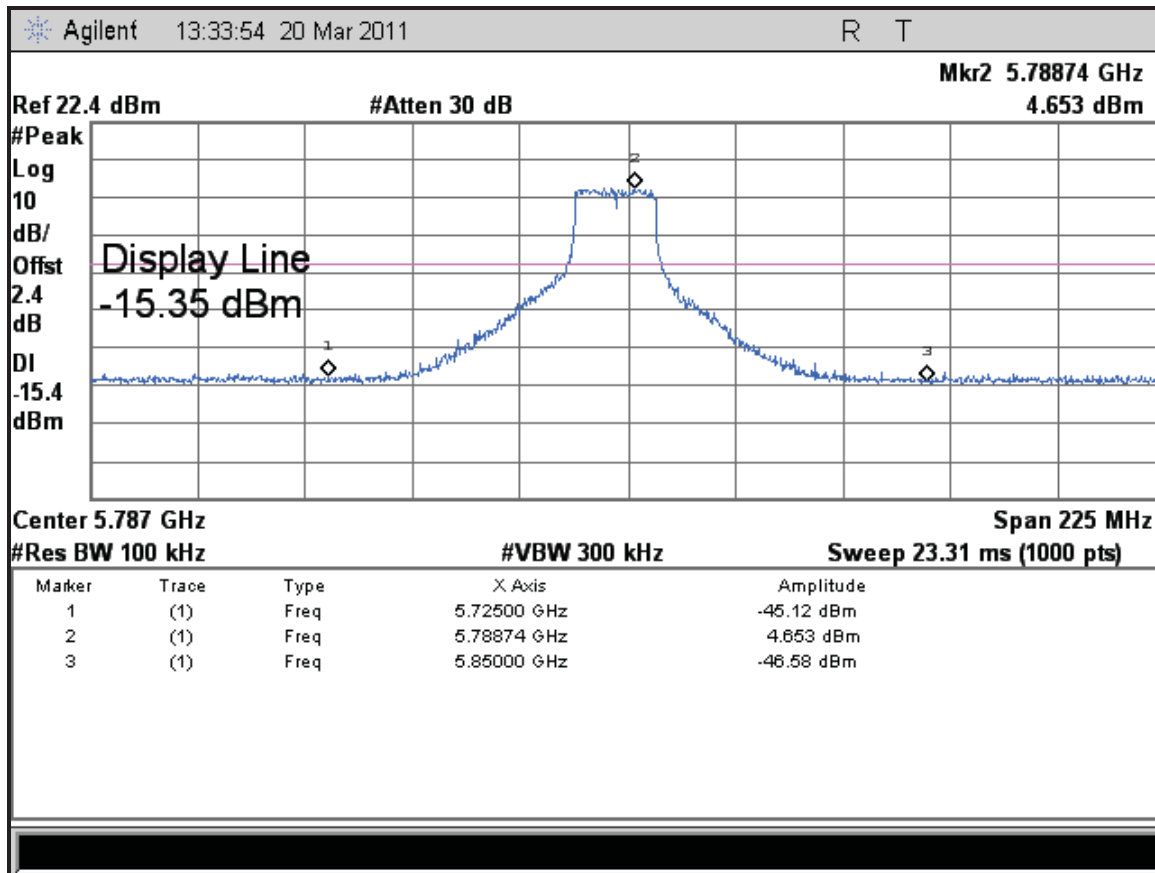
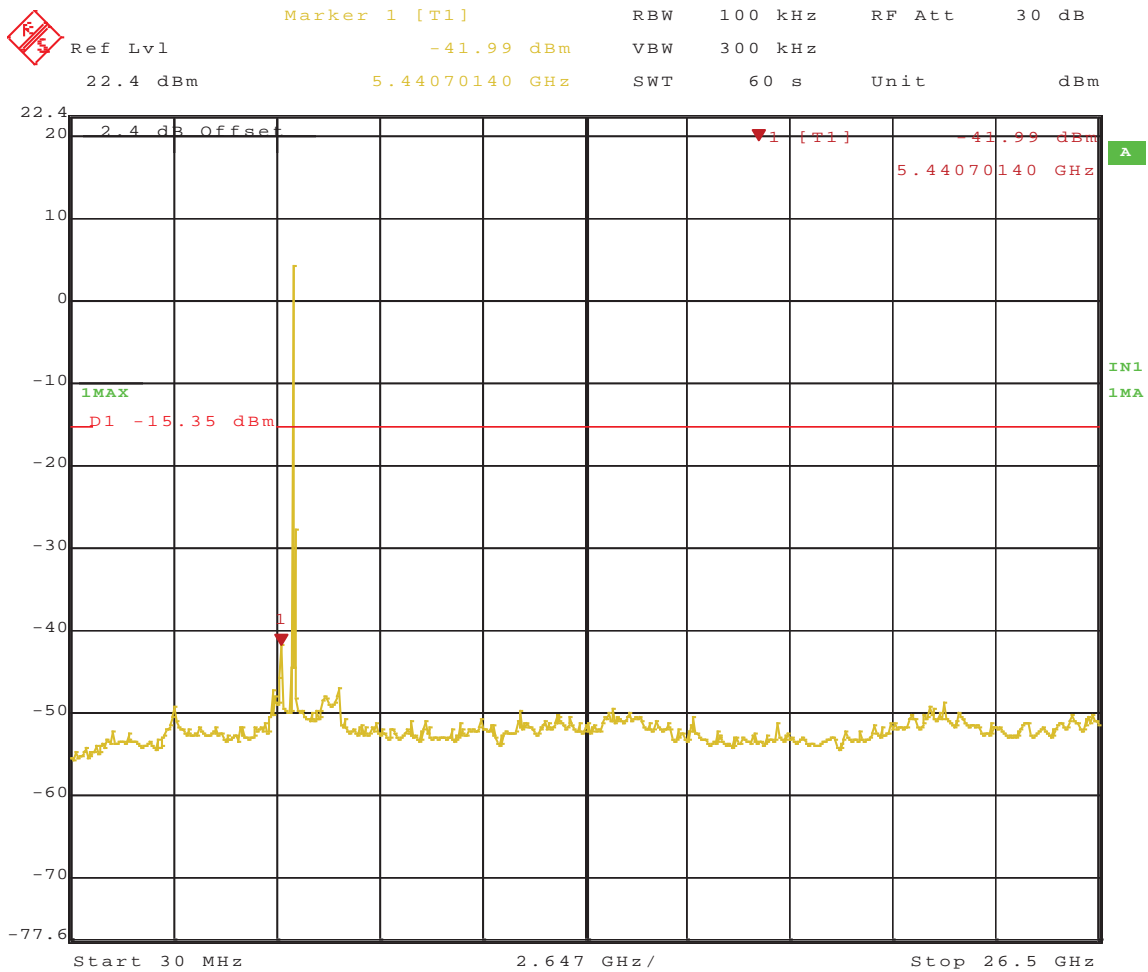
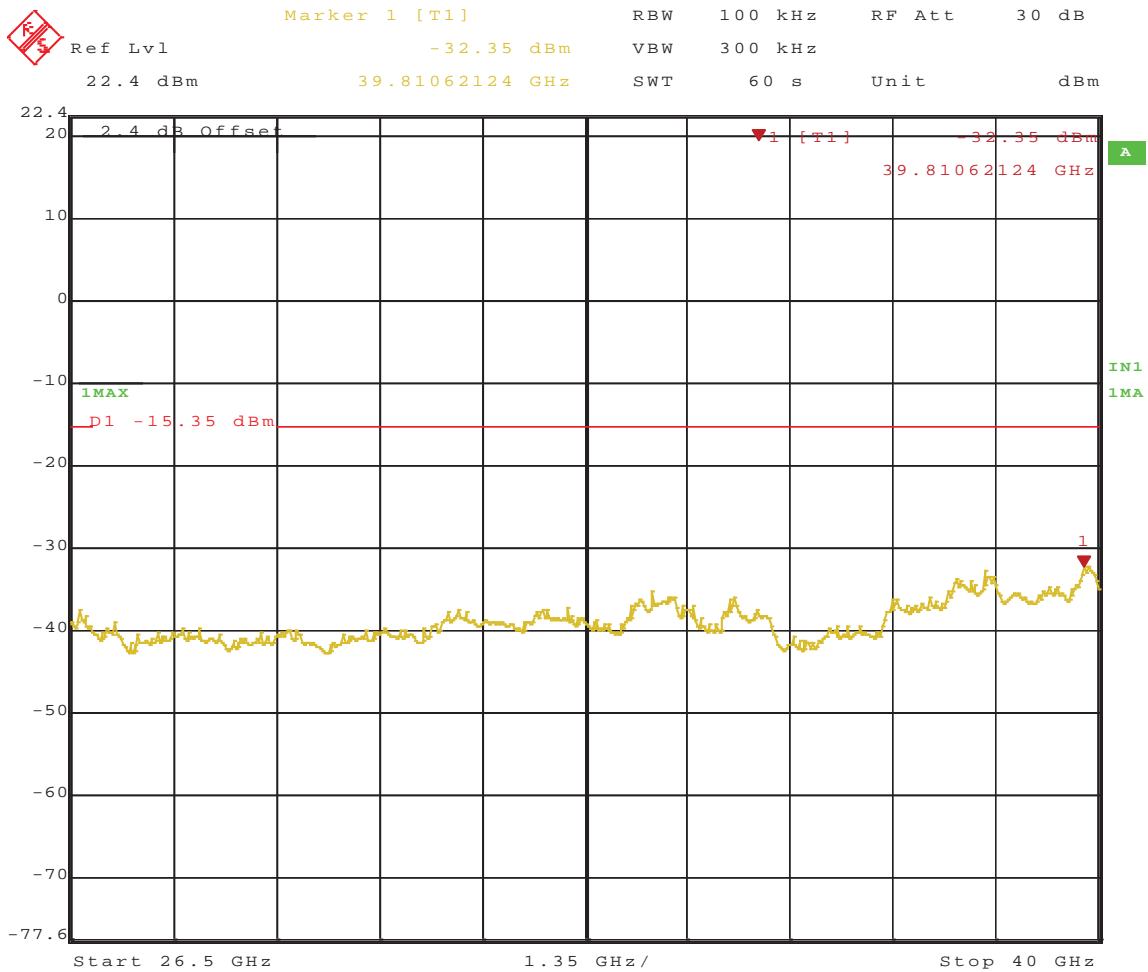

Figure 467: Band-edge Requirement at 802.11a, 24 Mbps 5785 MHz, Chain 2 – Plot 1



Date: 22.MAR.2011 14:26:43

Figure 468: Out of Band at 802.11a, 24 Mbps 5785 MHz, Chain 2 – Plot 2



Date: 22.MAR.2011 14:24:50

Figure 469: Out of Band at 802.11a, 24 Mbps 5785 MHz, Chain 2 – Plot 3

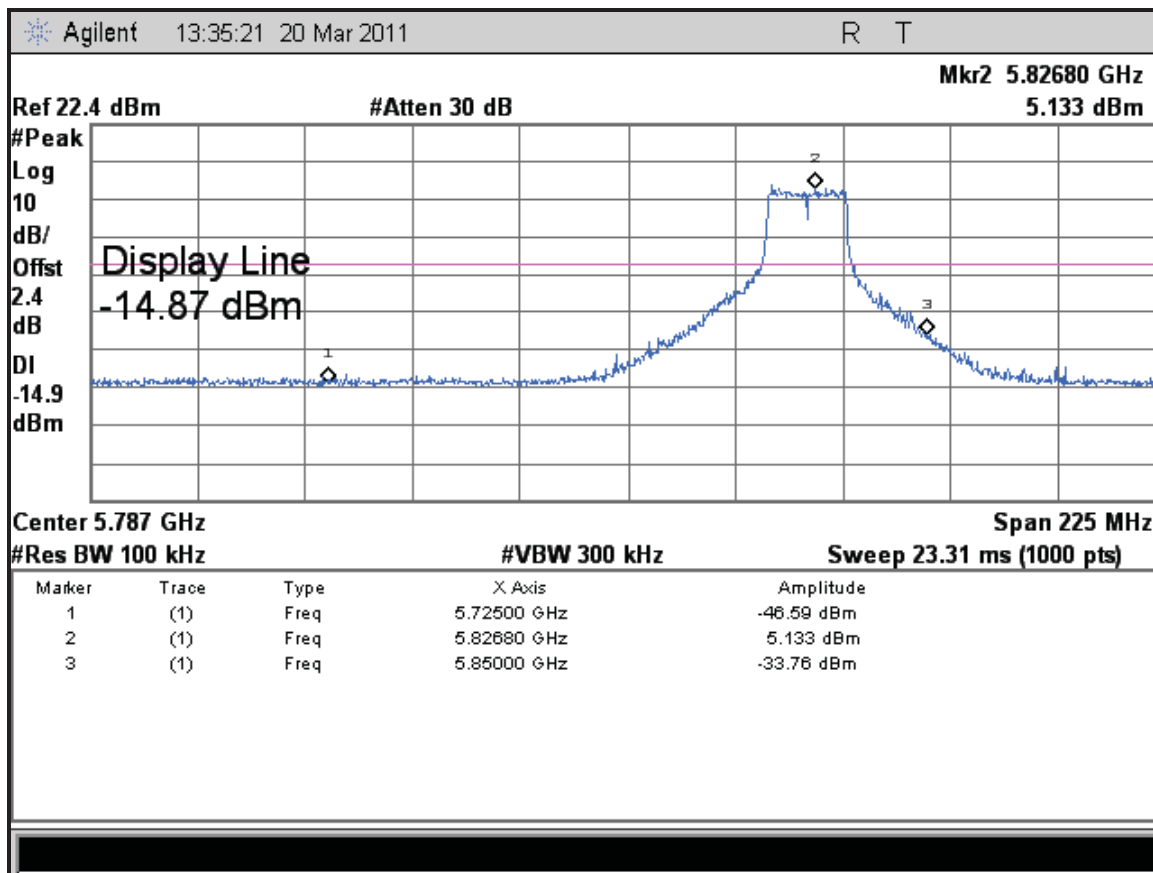
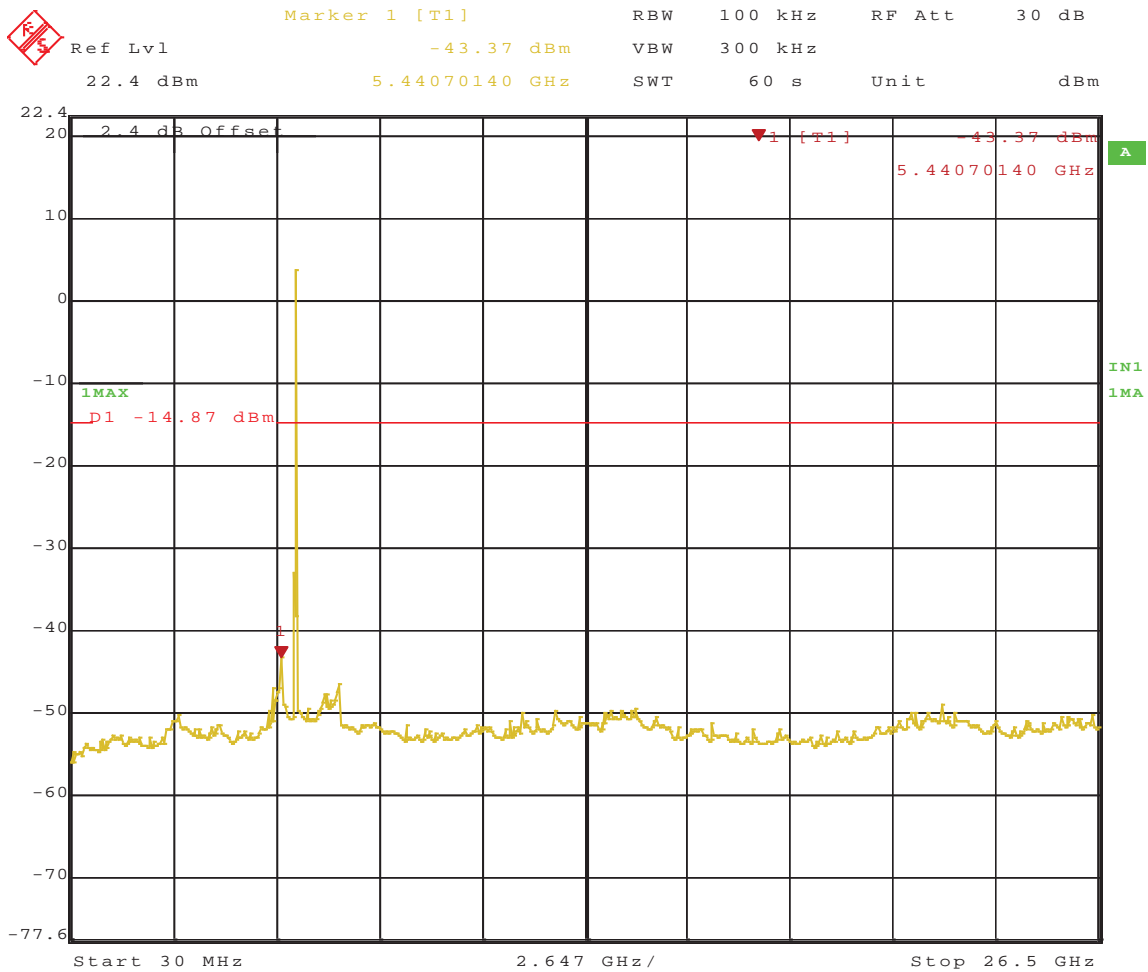
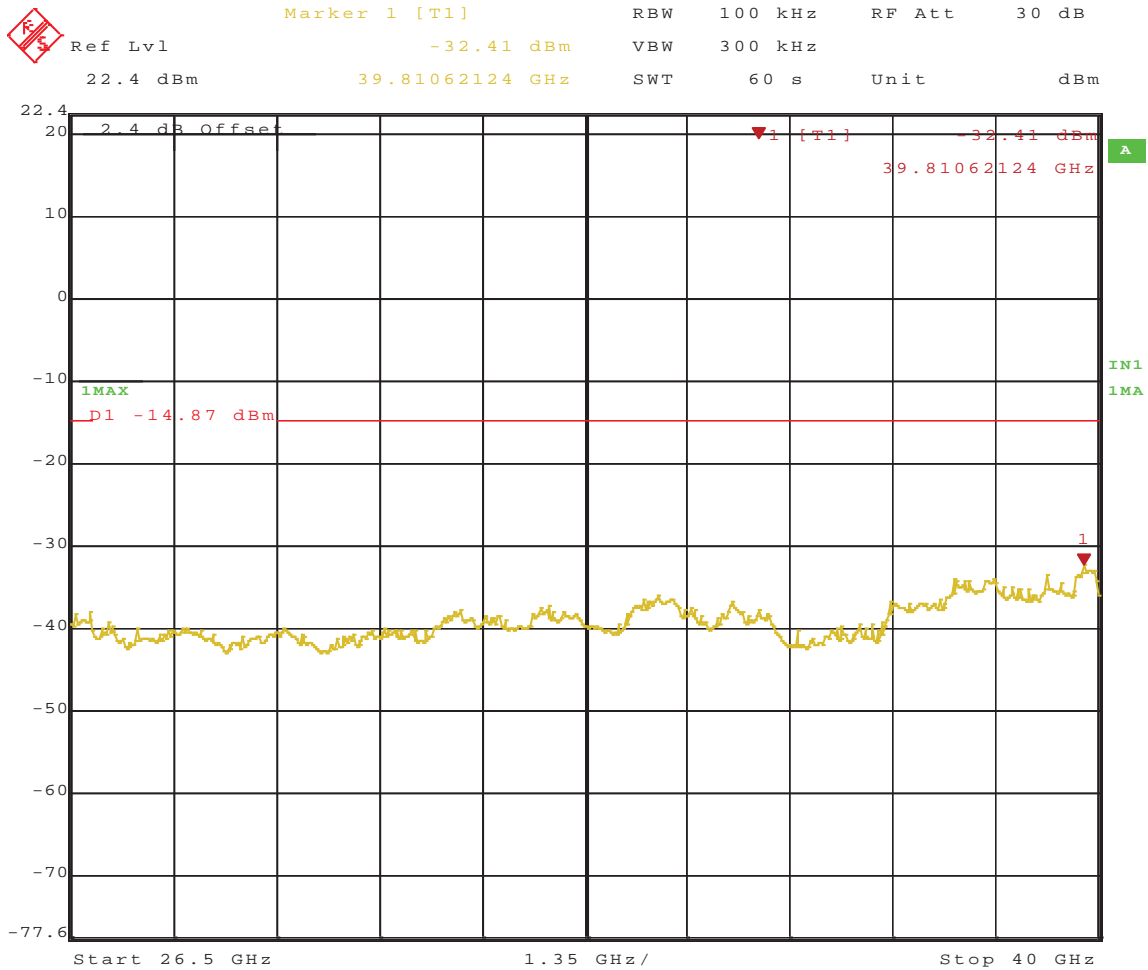

Figure 470: Band-edge Requirement at 802.11a, 24 Mbps 5825 MHz, Chain 2 – Plot 1



Date: 22.MAR.2011 14:29:08

Figure 471: Out of Band at 802.11a, 24 Mbps 5825 MHz, Chain 2 – Plot 2



Date: 22.MAR.2011 14:30:34

Figure 472: Out of Band at 802.11a, 24 Mbps 5825 MHz, Chain 2 – Plot 3

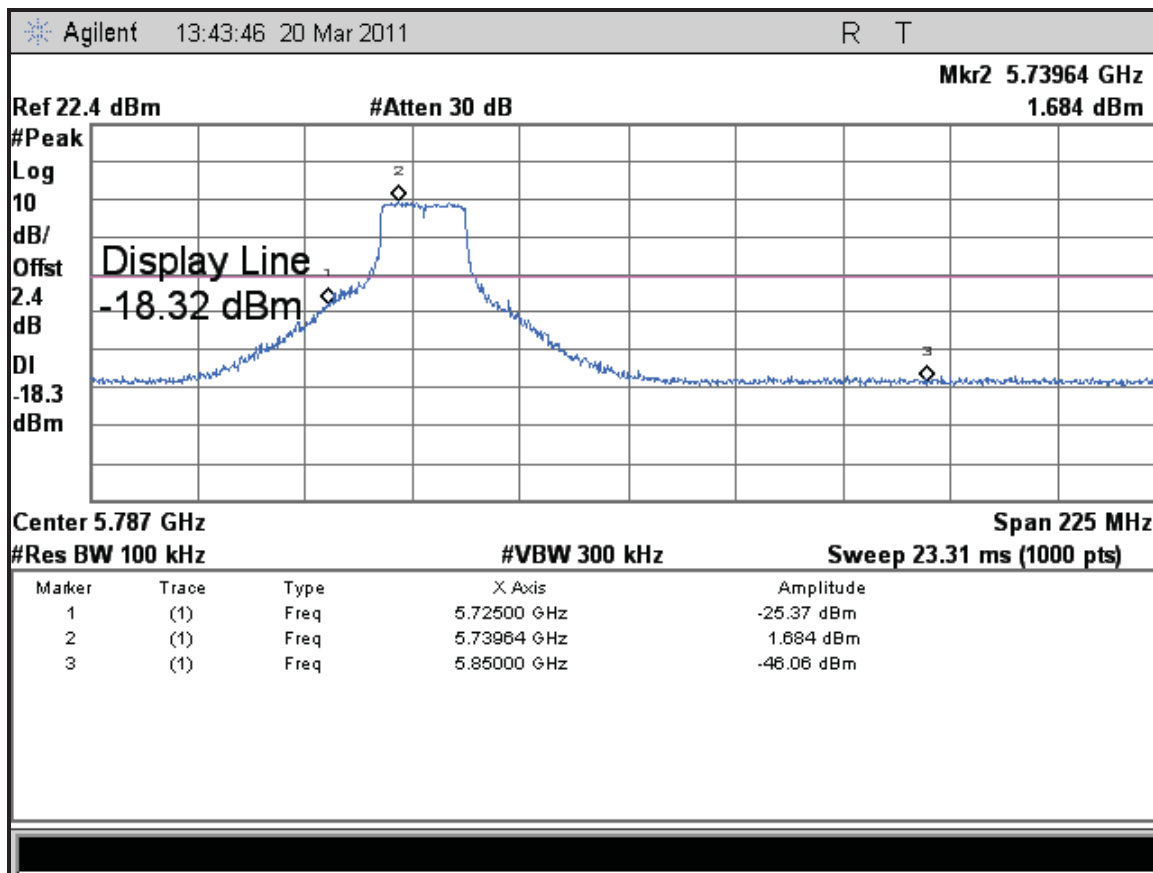
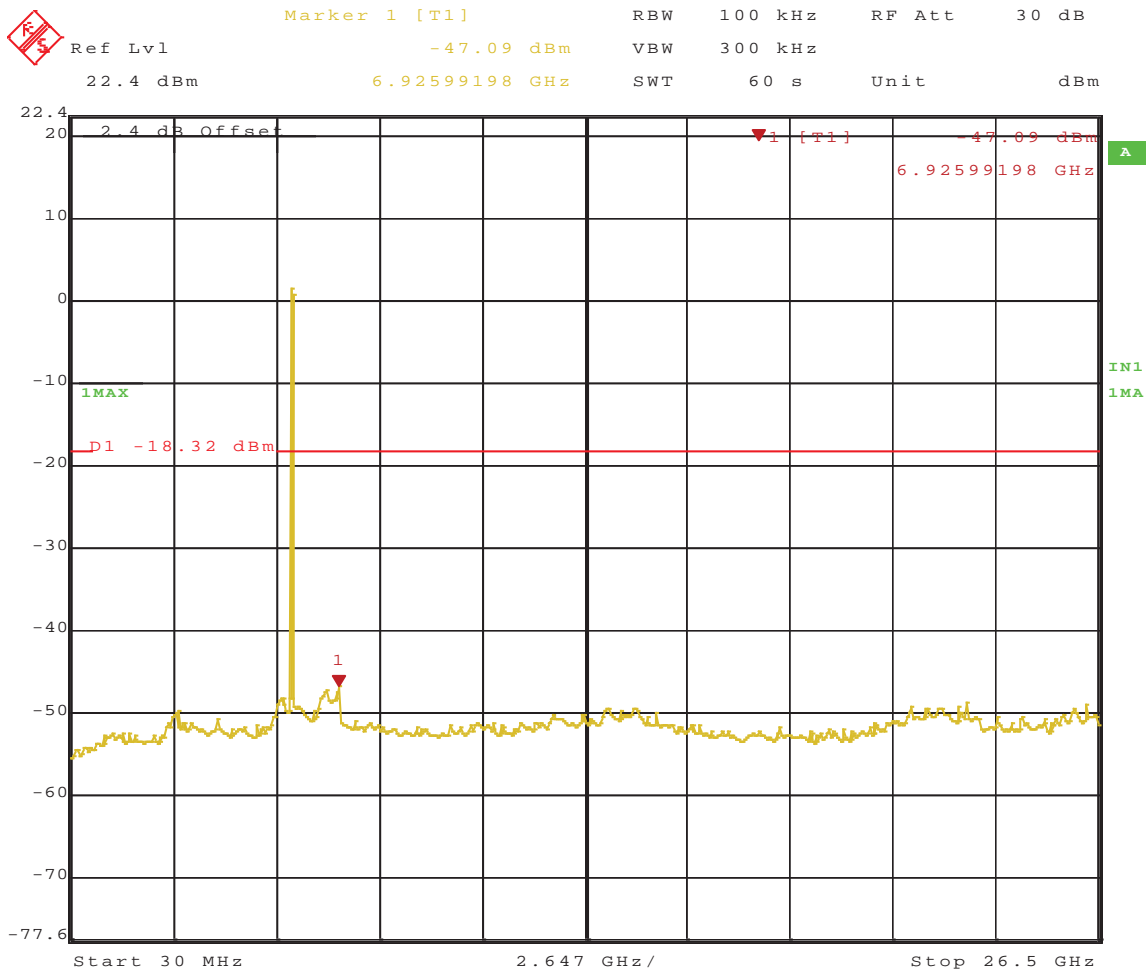
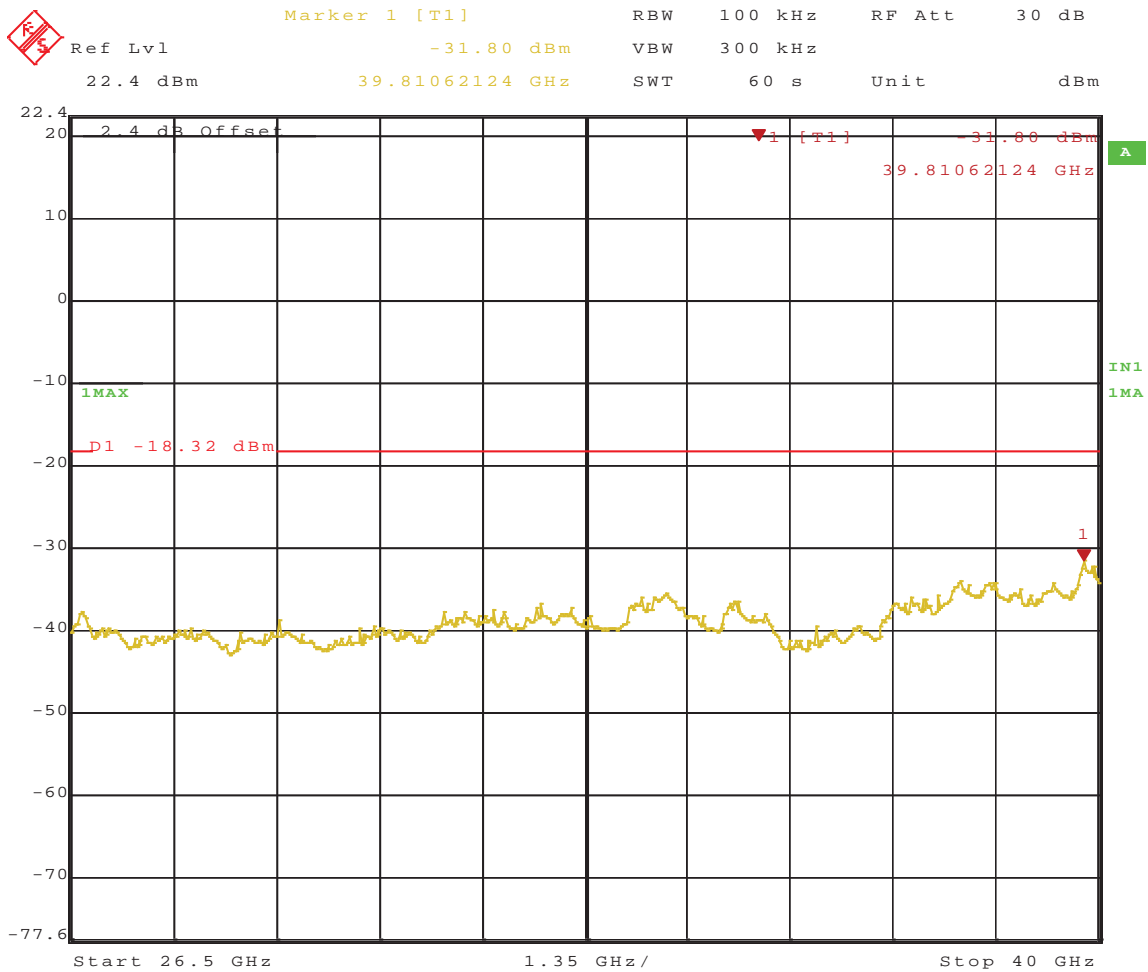

Figure 473: Band-edge Requirement at 802.11n HT20, 6.5 Mbps 5745 MHz, Chain 0 – Plot 1



Date: 22.MAR.2011 14:40:20

Figure 474: Out of Band at 802.11n HT20, 6.5 Mbps 5745 MHz, Chain 0 – Plot 2



Date: 22.MAR.2011 14:33:56

Figure 475: Out of Band at 802.11n HT20, 6.5 Mbps 5745 MHz, Chain 0 – Plot 3

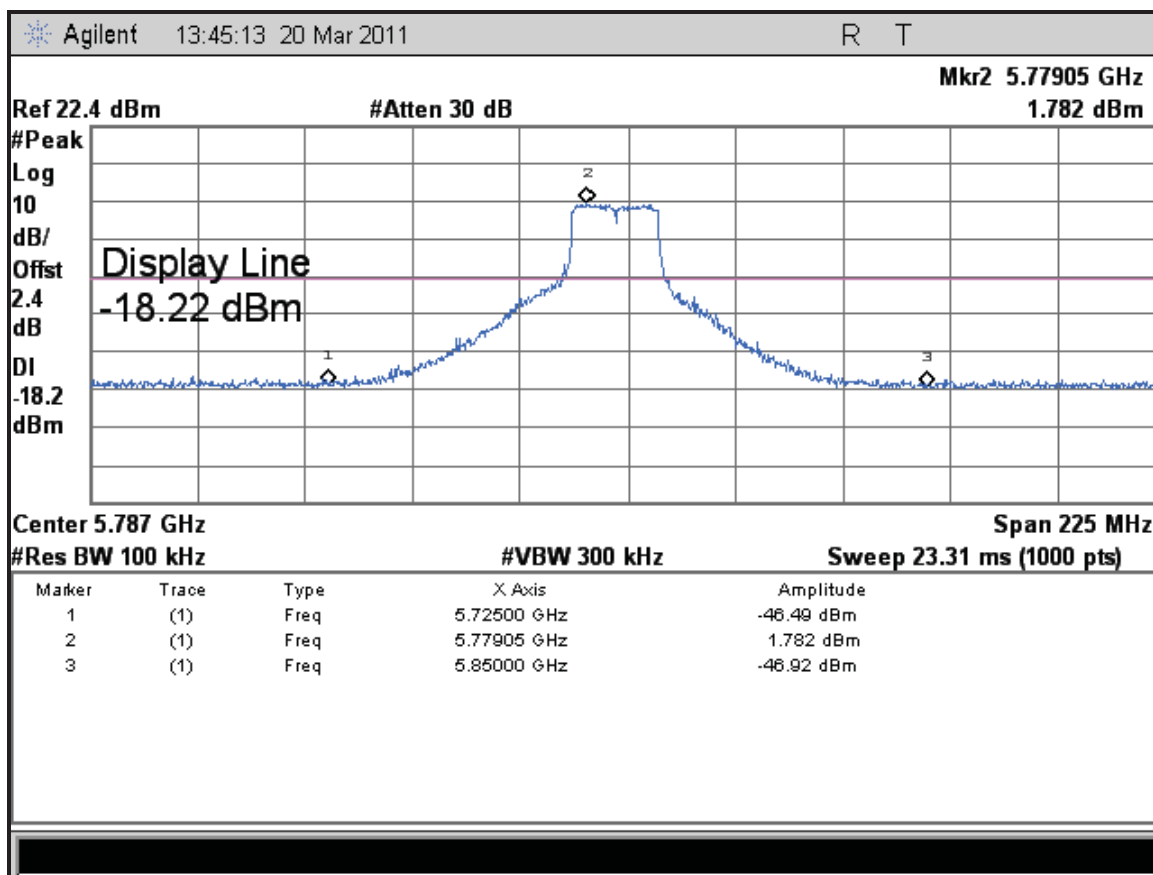
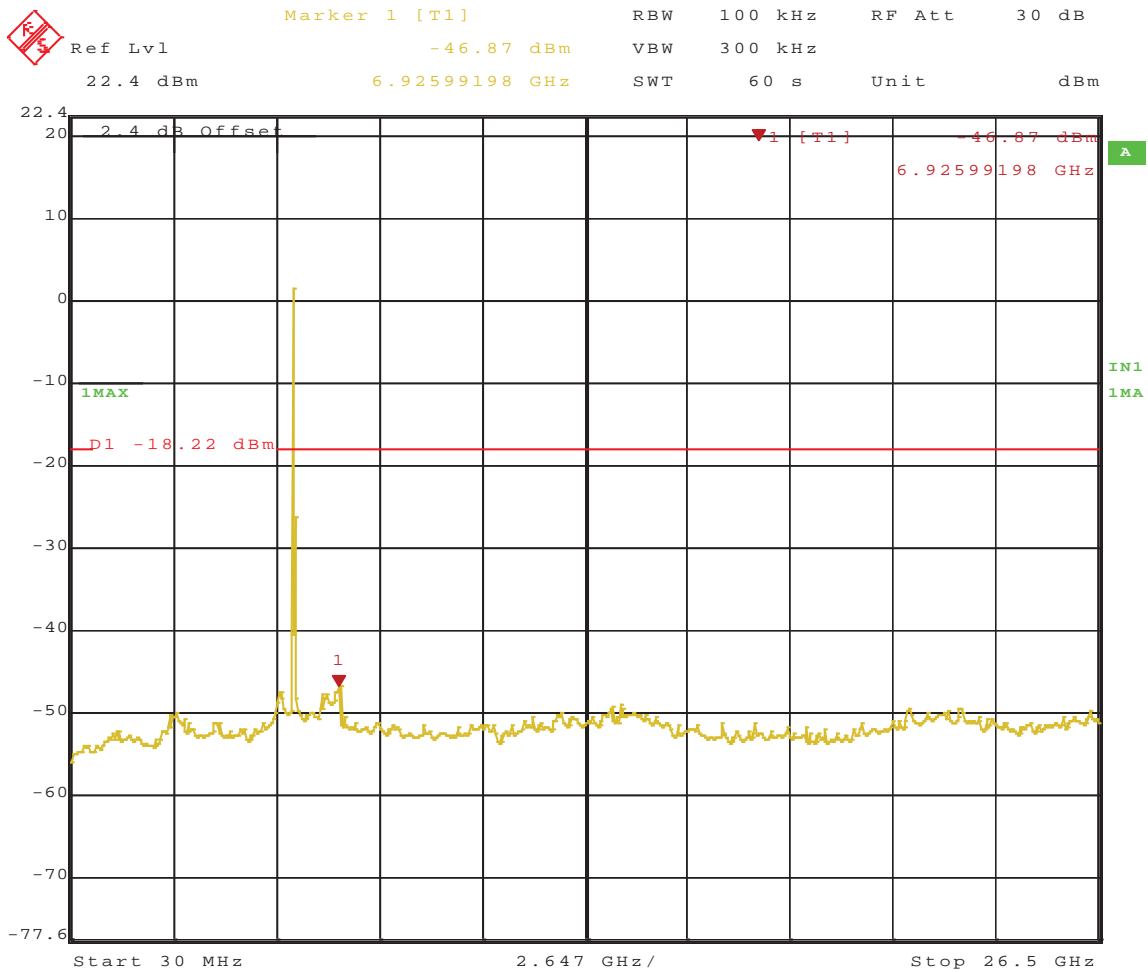
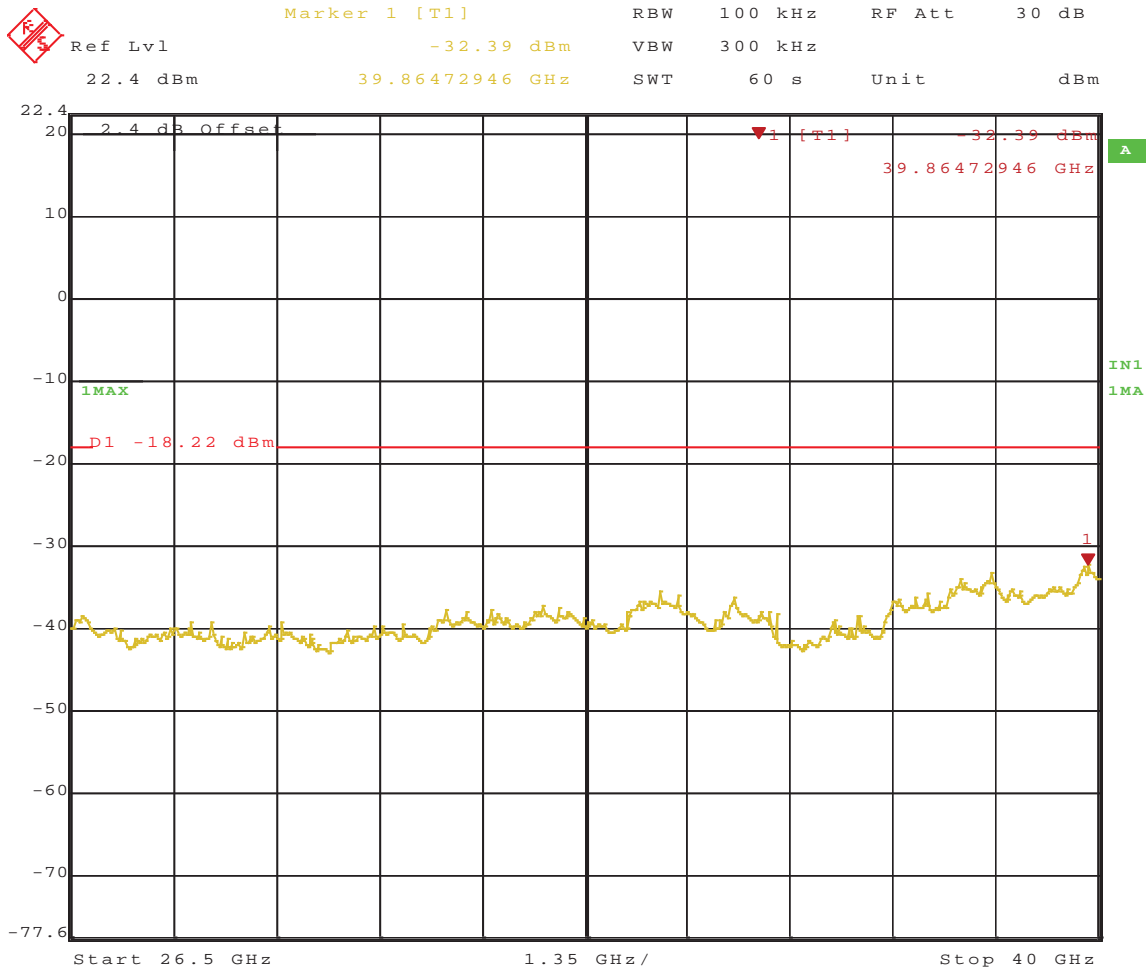

Figure 476: Band-edge Requirement at 802.11n HT20, 6.5 Mbps 5785 MHz, Chain 0 – Plot 1



Date: 22.MAR.2011 14:44:33

Figure 477: Out of Band at 802.11n HT20, 6.5 Mbps 5785 MHz, Chain 0 – Plot 2



Date: 22.MAR.2011 14:46:22

Figure 478: Out of Band at 802.11n HT20, 6.5 Mbps 5785 MHz, Chain 0 – Plot 3

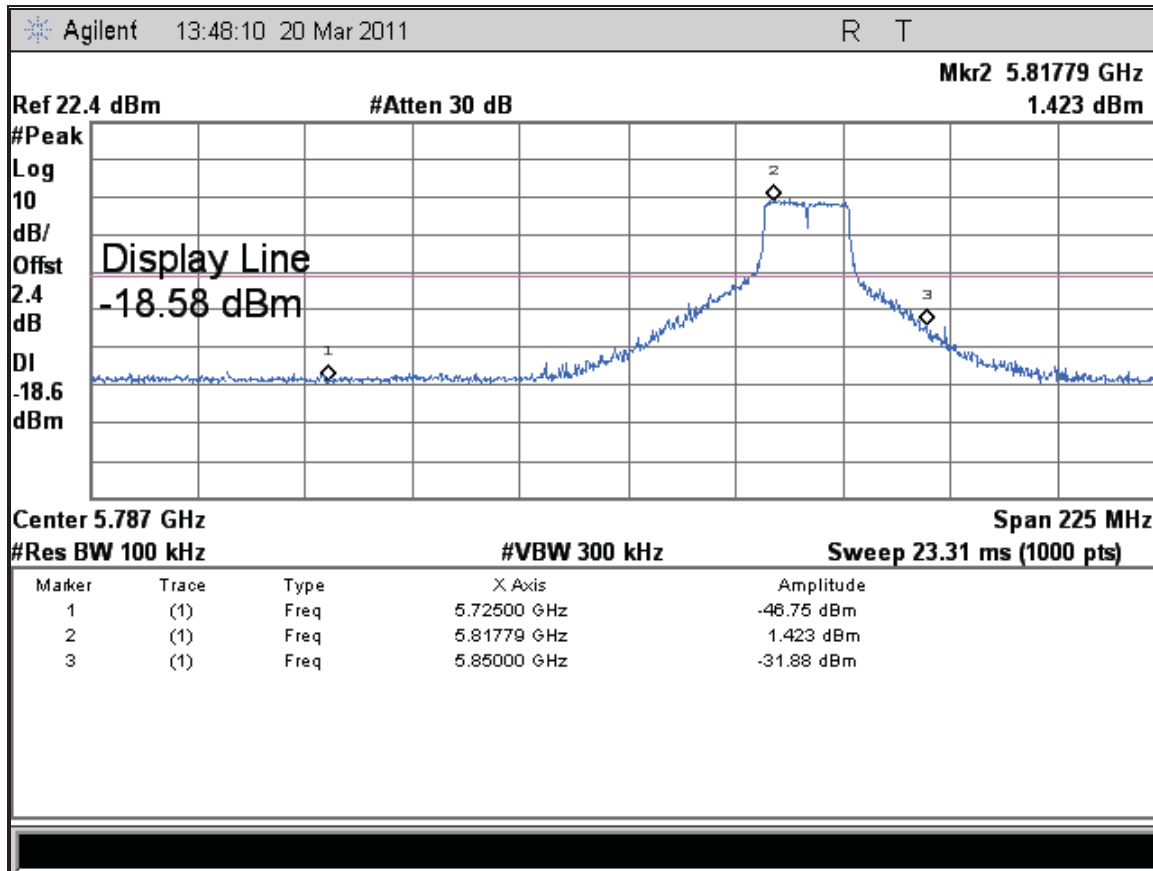
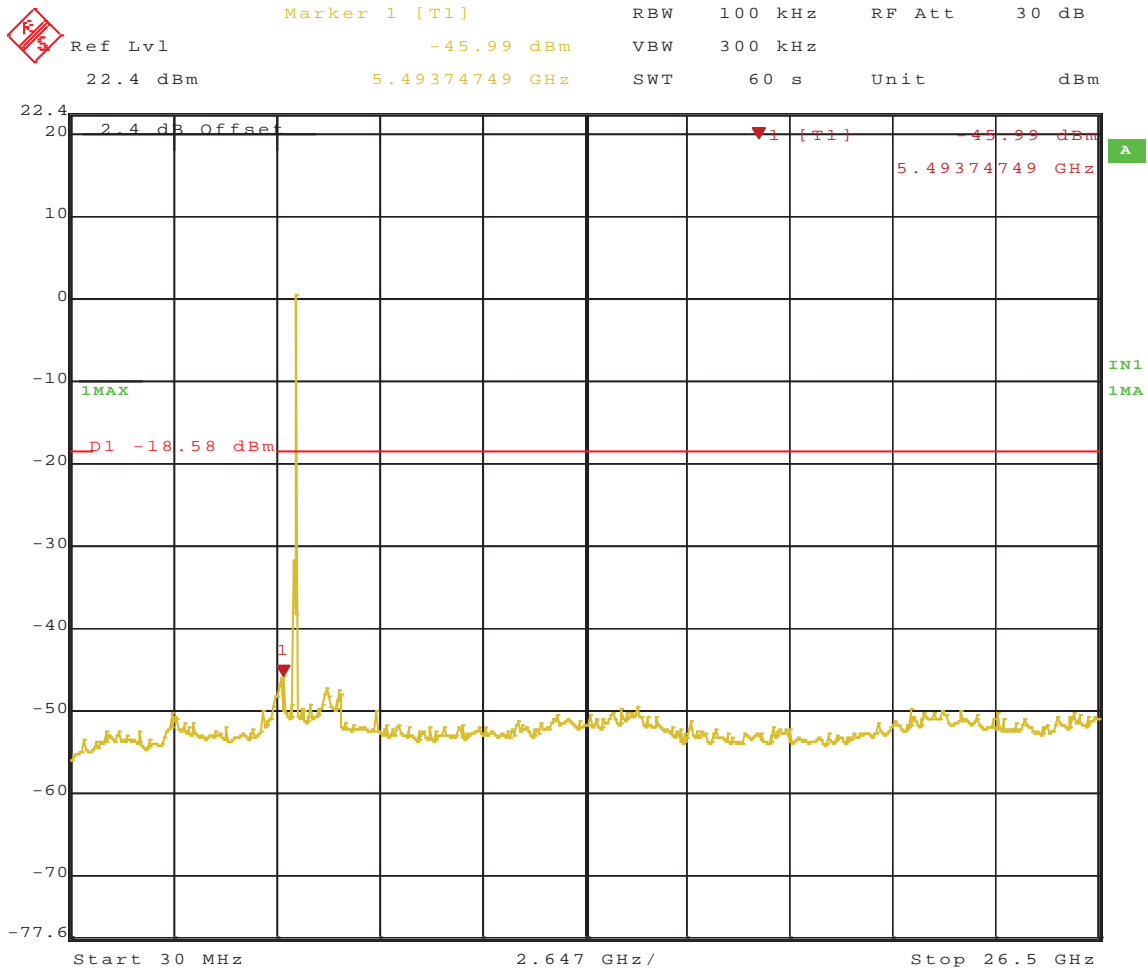
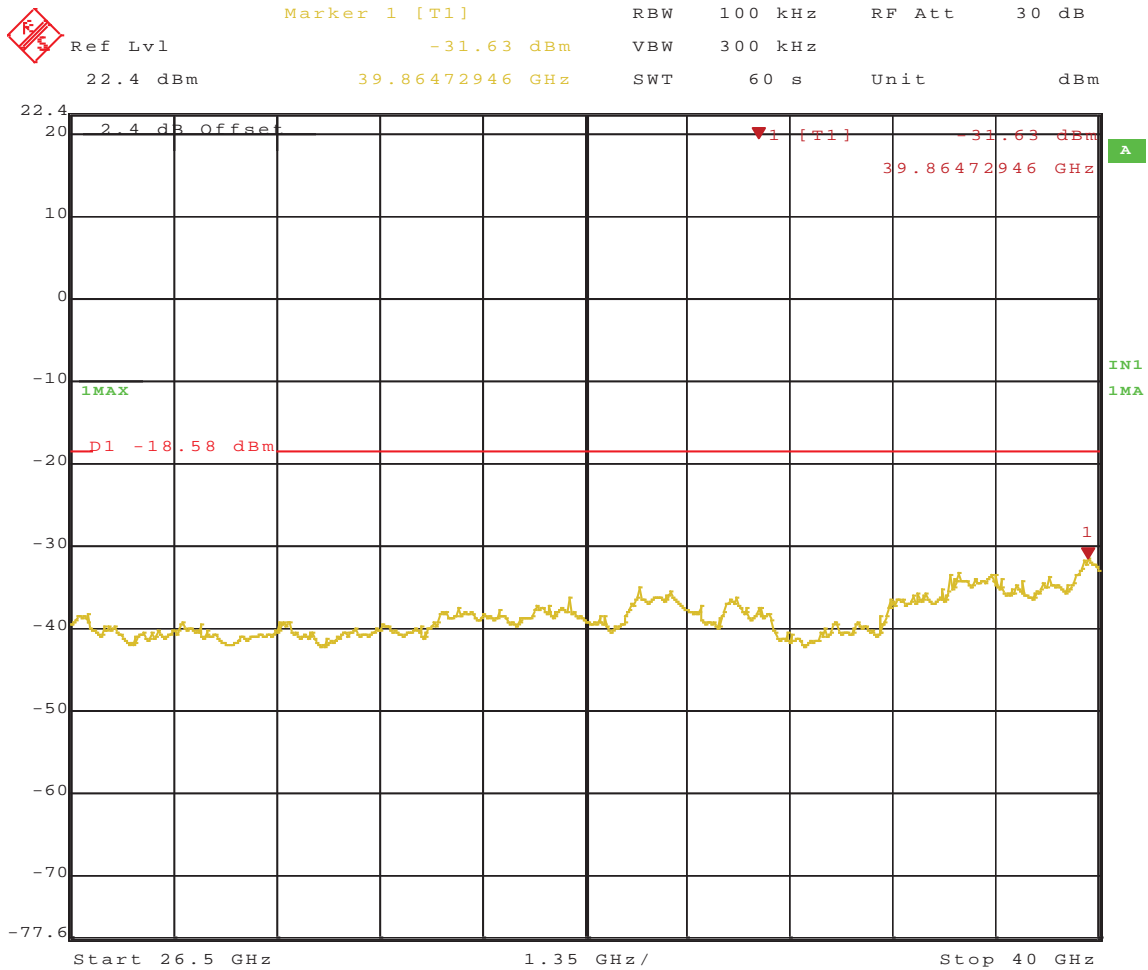

Figure 479: Band-edge Requirement at 802.11n HT20, 6.5 Mbps 5825 MHz, Chain 0 – Plot 1



Date: 22.MAR.2011 14:53:59

Figure 480: Out of Band at 802.11n HT20, 6.5 Mbps 5825 MHz, Chain 0 – Plot 2



Date: 22.MAR.2011 14:52:16

Figure 481: Out of Band at 802.11n HT20, 6.5 Mbps 5825 MHz, Chain 0 – Plot 3

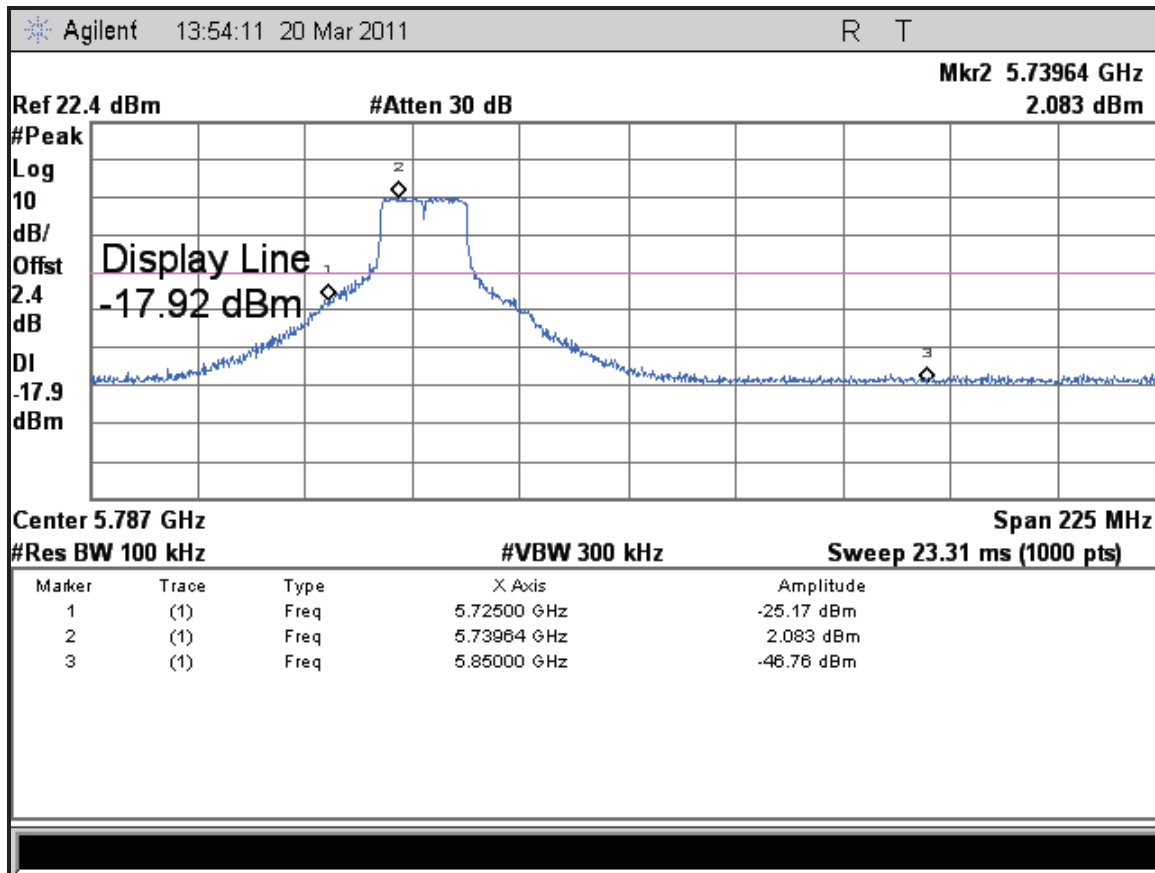
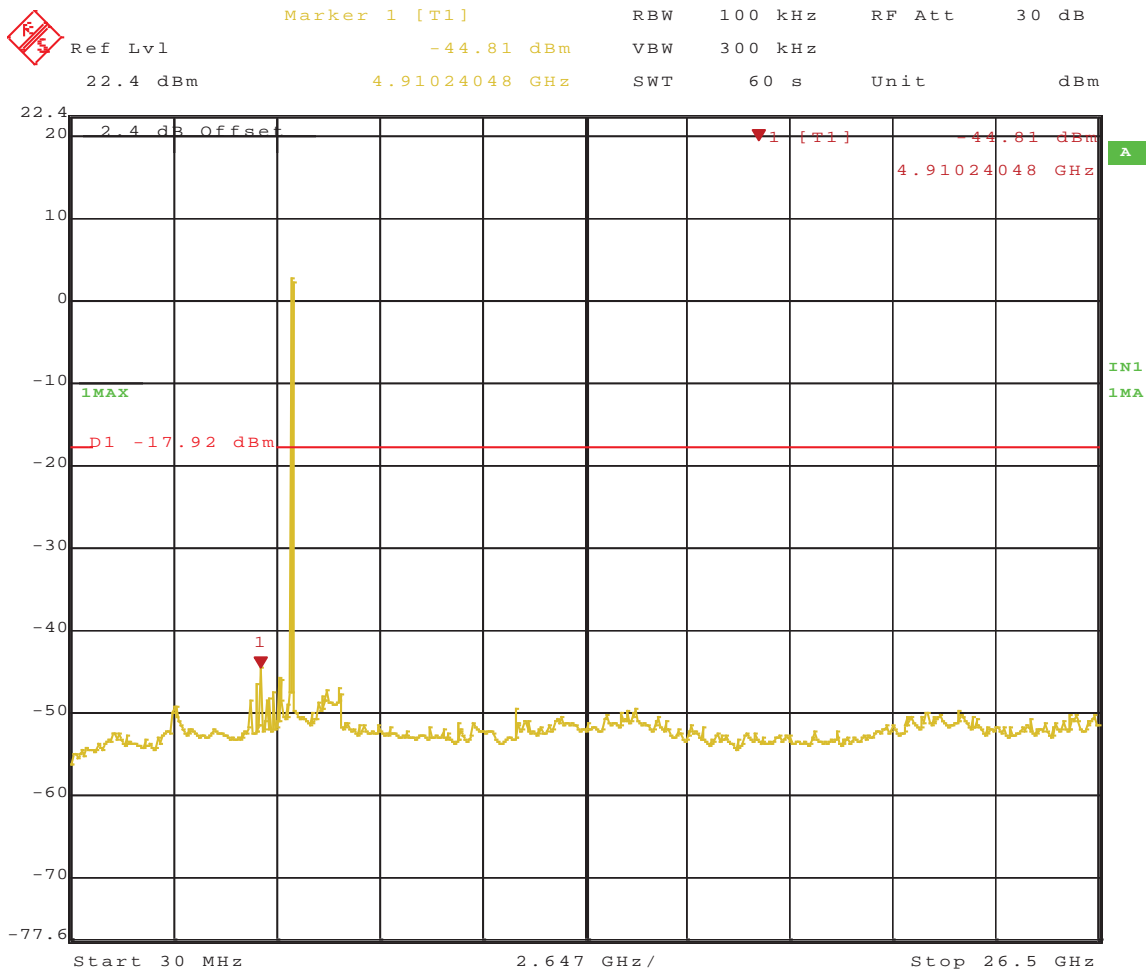
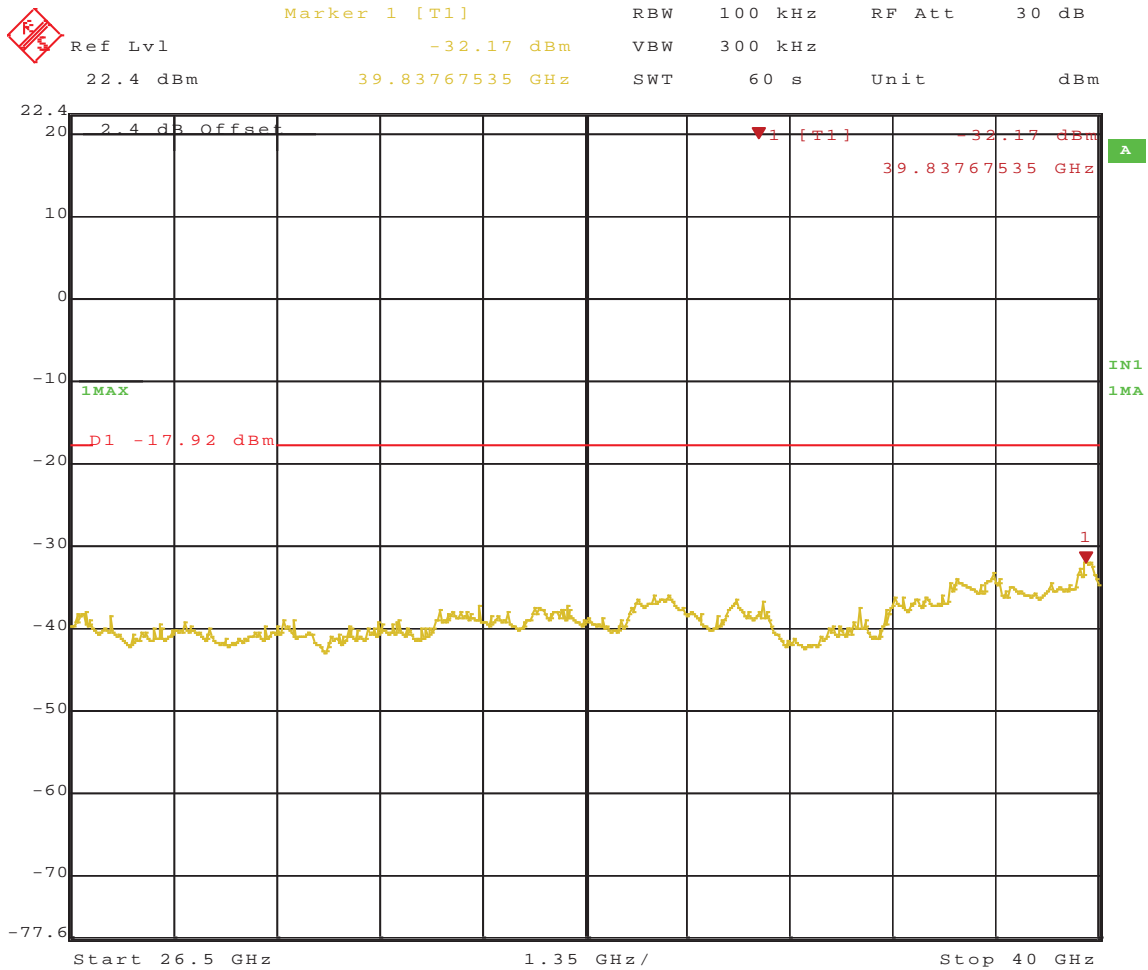

Figure 482: Band-edge Requirement at 802.11n HT20, 6.5 Mbps 5745 MHz, Chain 1 – Plot 1



Date: 22.MAR.2011 14:56:41

Figure 483: Out of Band at 802.11n HT20, 6.5 Mbps 5745 MHz, Chain 1 – Plot 2



Date: 22.MAR.2011 14:59:15

Figure 484: Out of Band at 802.11n HT20, 6.5 Mbps 5745 MHz, Chain 1 – Plot 3

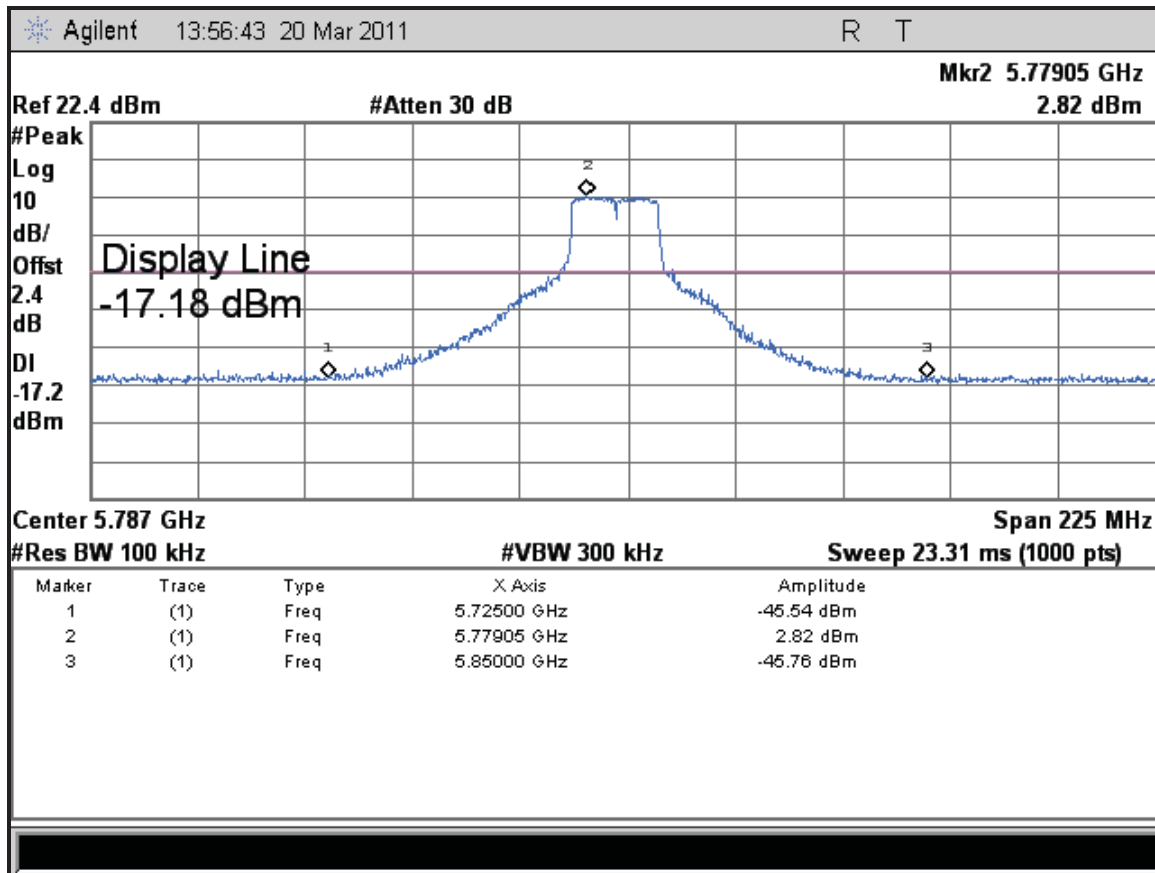
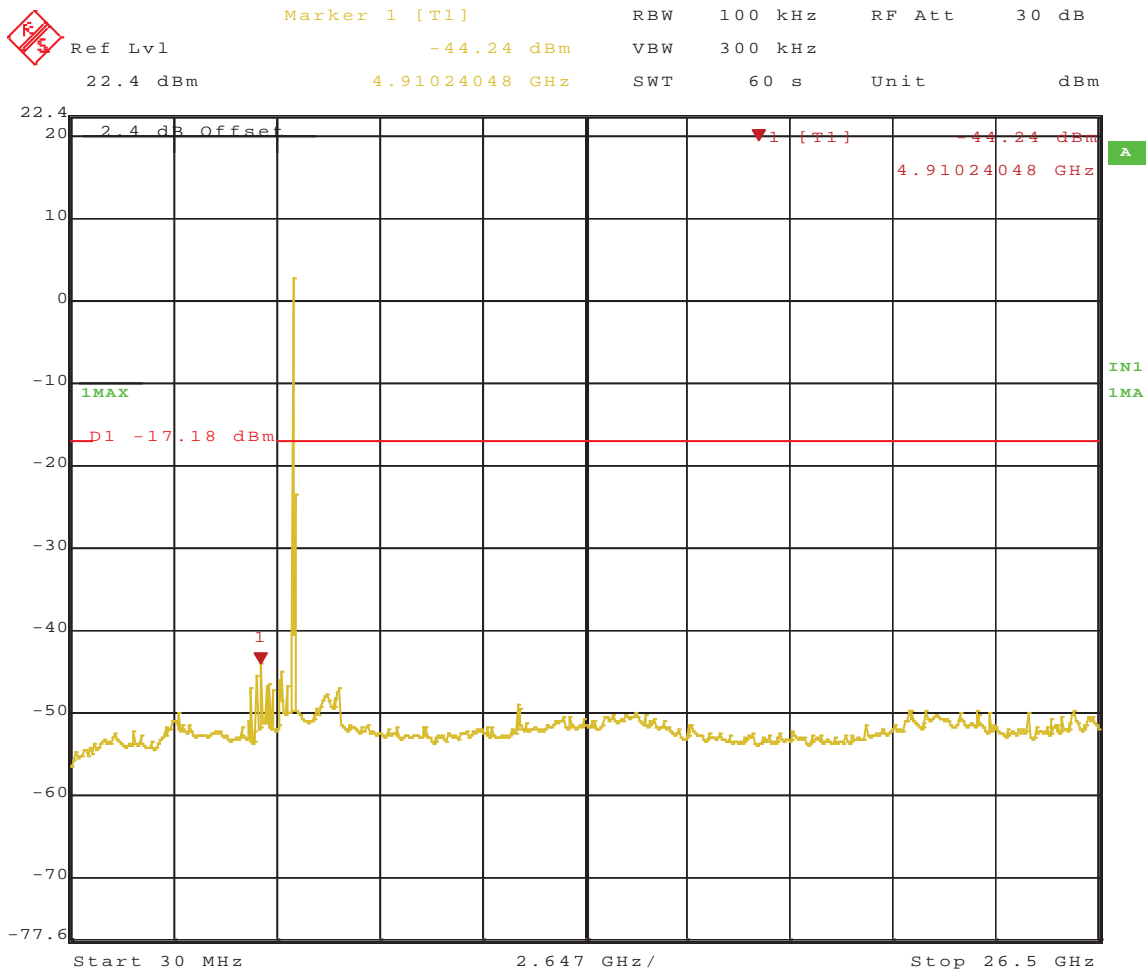
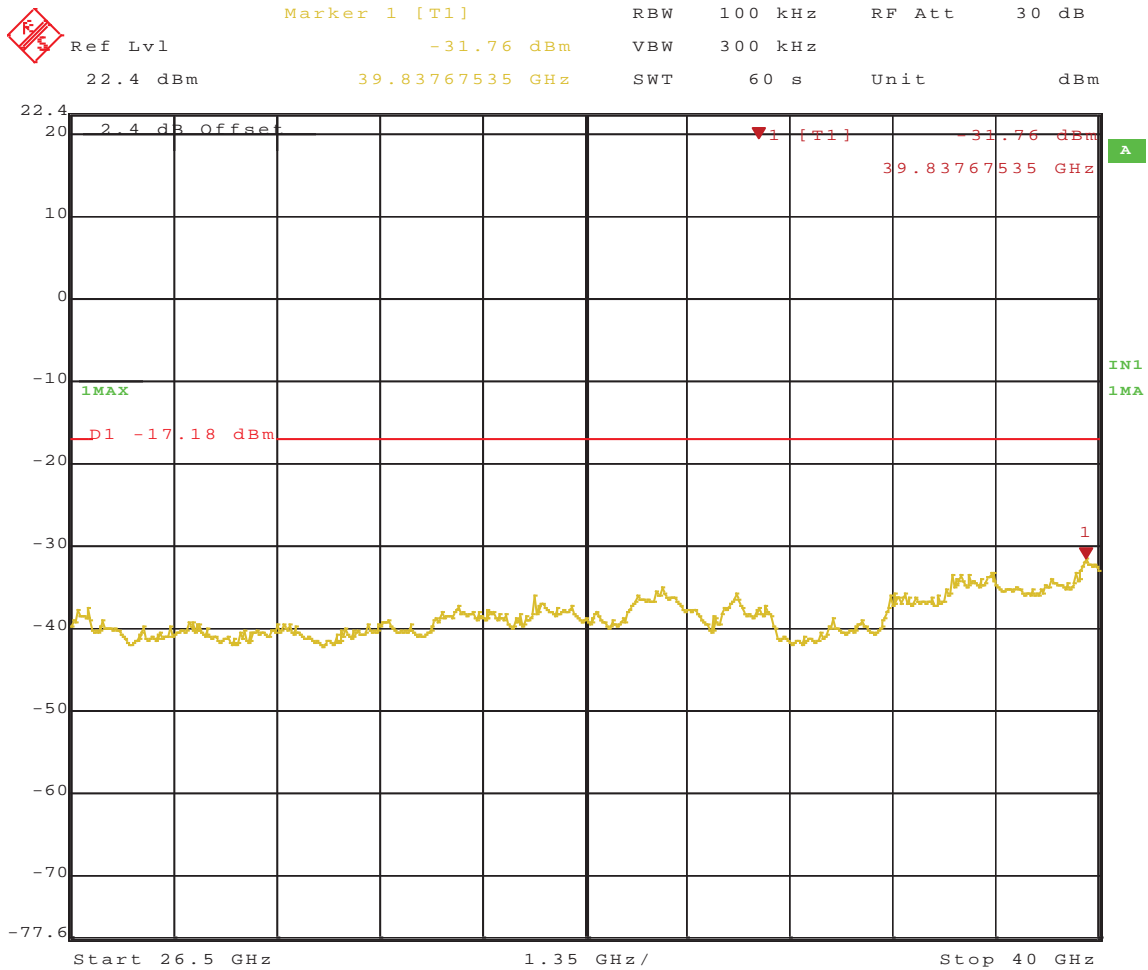

Figure 485: Band-edge Requirement at 802.11n HT20, 6.5 Mbps 5785 MHz, Chain 1 – Plot 1



Date: 22.MAR.2011 15:08:36

Figure 486: Out of Band at 802.11n HT20, 6.5 Mbps 5785 MHz, Chain 1 – Plot 2



Date: 22.MAR.2011 15:06:33

Figure 487: Out of Band at 802.11n HT20, 6.5 Mbps 5785 MHz, Chain 1 – Plot 3

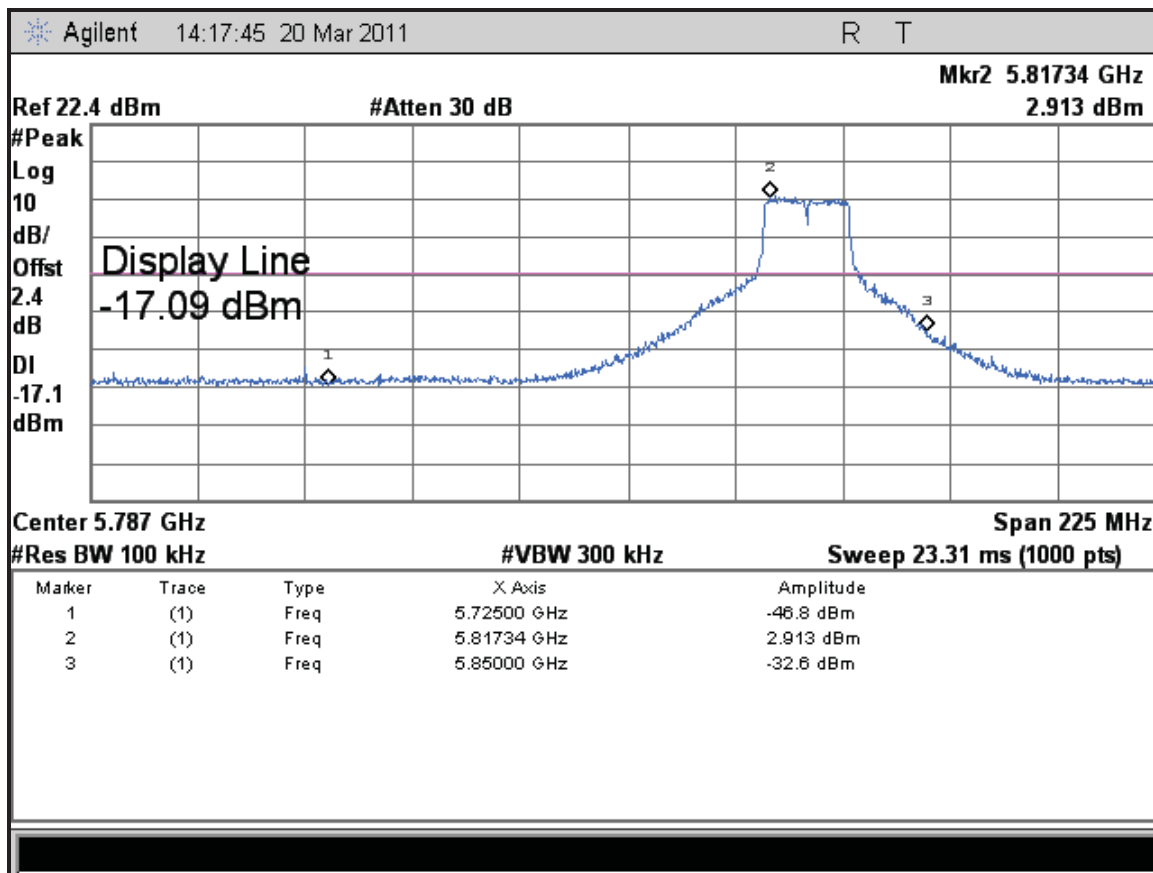
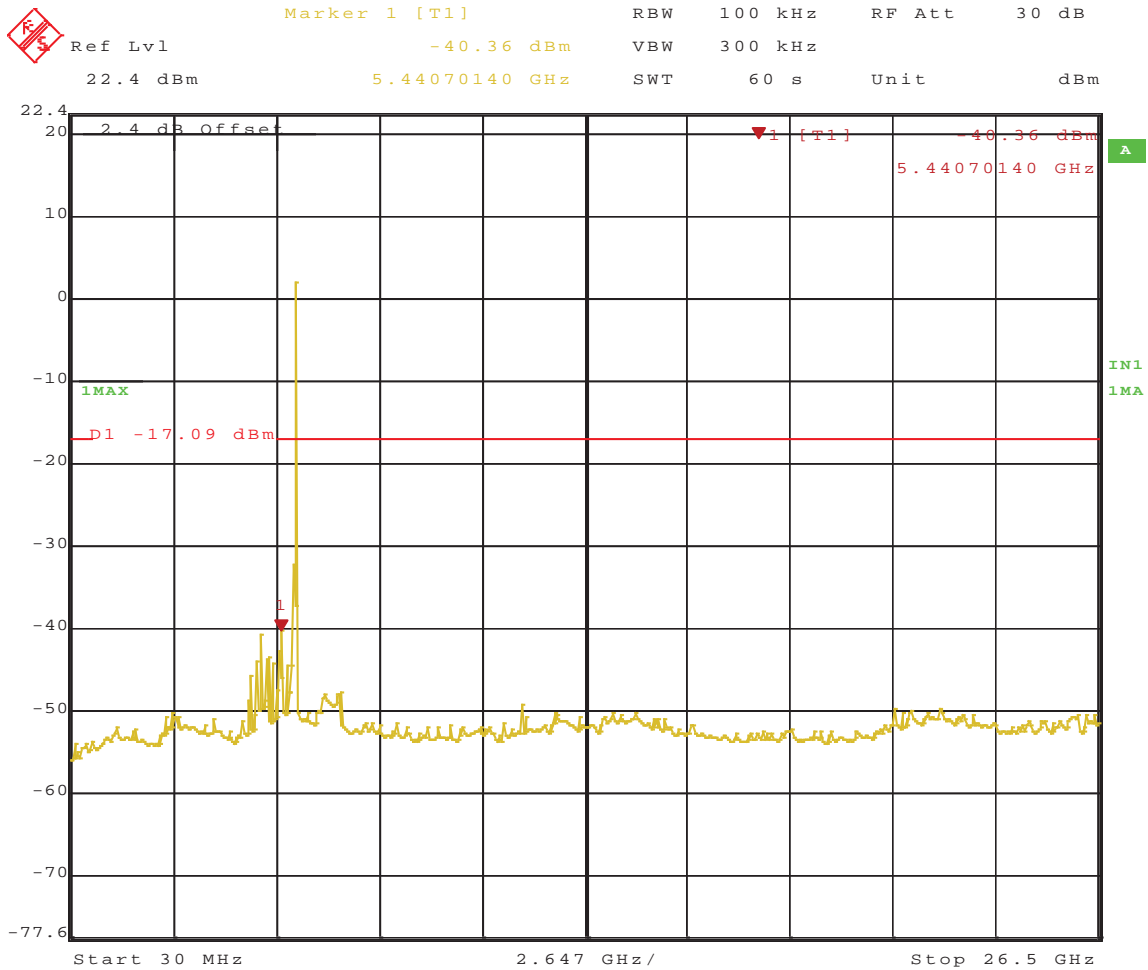
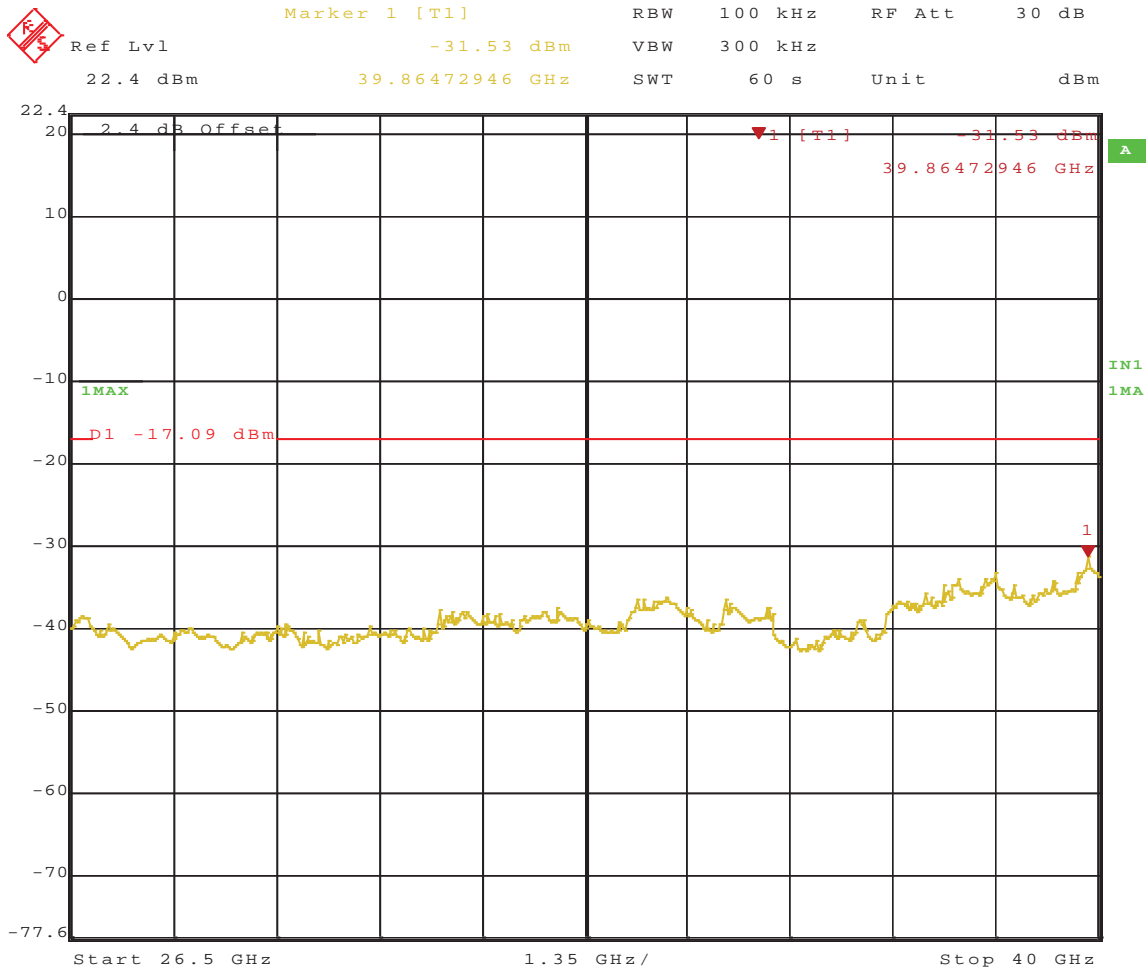

Figure 488: Band-edge Requirement at 802.11n HT20, 6.5 Mbps 5825 MHz, Chain 1 – Plot 1



Date: 22.MAR.2011 15:10:19

Figure 489: Out of Band at 802.11n HT20, 6.5 Mbps 5825 MHz, Chain 1 – Plot 2



Date: 22.MAR.2011 15:11:58

Figure 490: Out of Band at 802.11n HT20, 6.5 Mbps 5825 MHz, Chain 1 – Plot 3

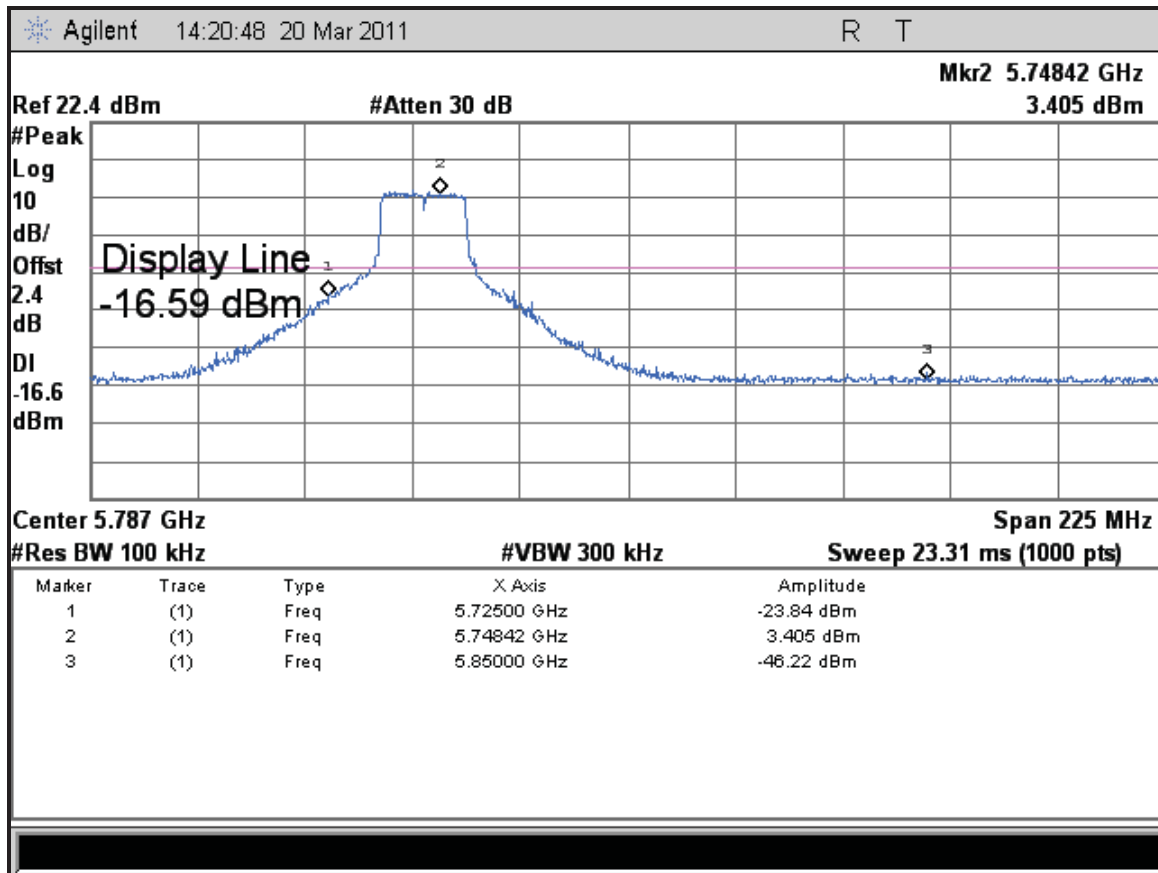
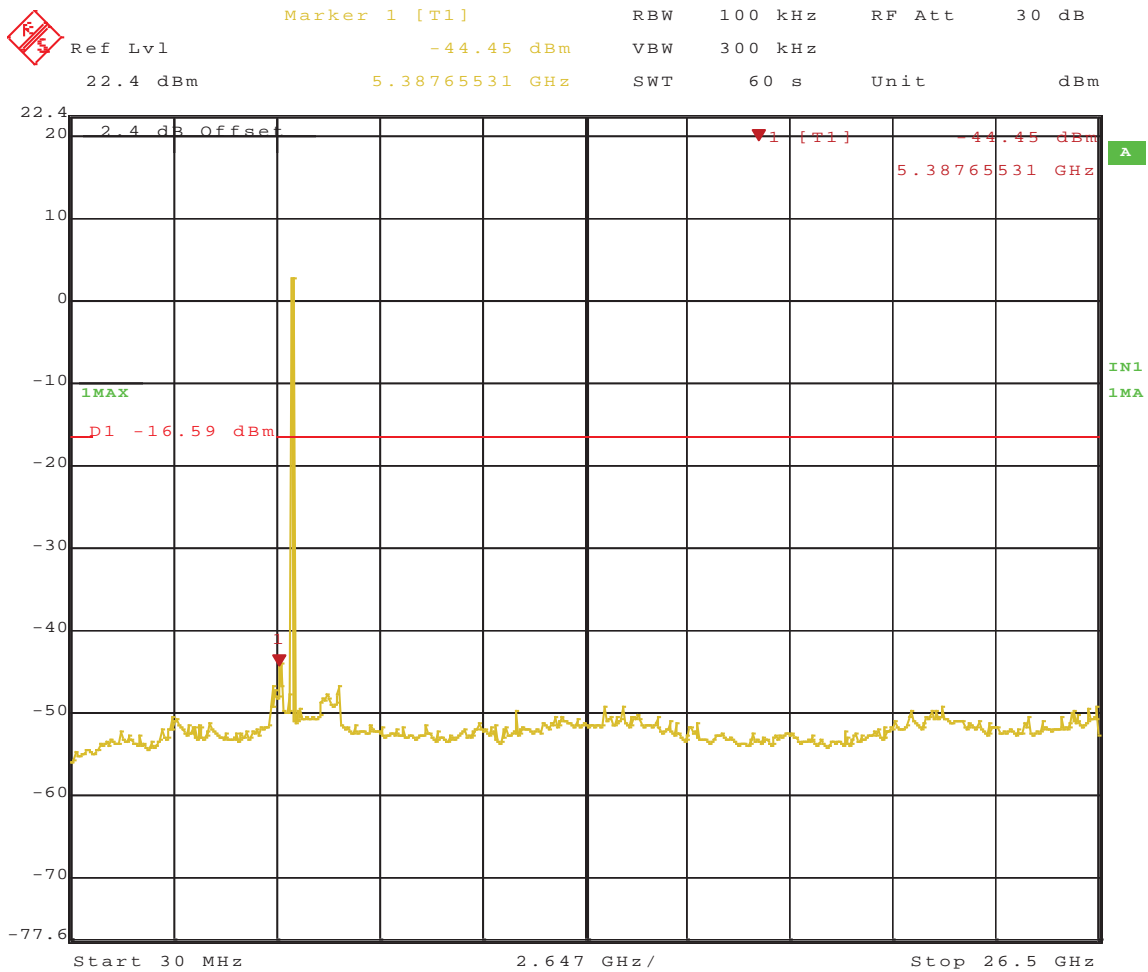
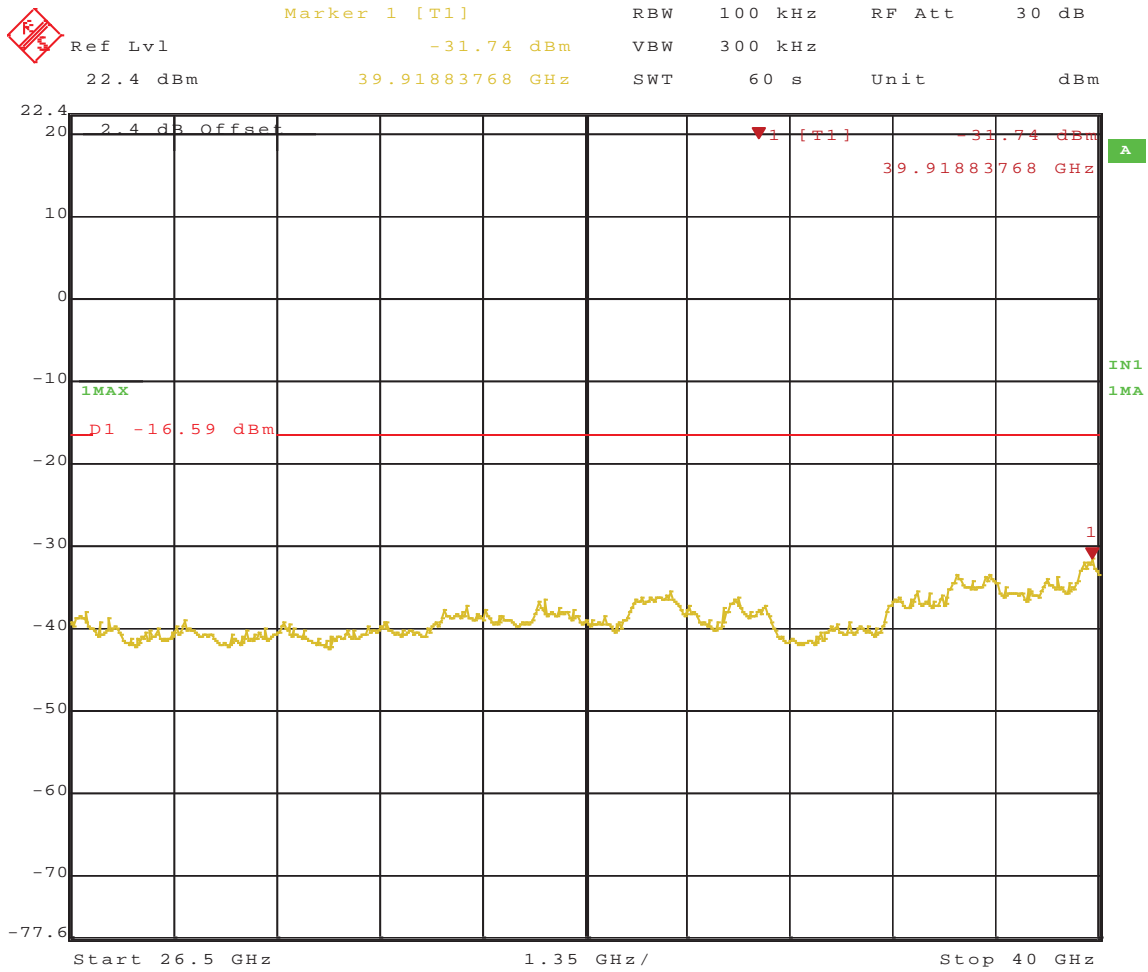

Figure 491: Band-edge Requirement at 802.11n HT20, 6.5 Mbps 5745 MHz, Chain 2 – Plot 1



Date: 22.MAR.2011 15:19:31

Figure 492: Out of Band at 802.11n HT20, 6.5 Mbps 5745 MHz, Chain 2 – Plot 2



Date: 22.MAR.2011 15:17:18

Figure 493: Out of Band at 802.11n HT20, 6.5 Mbps 5745 MHz, Chain 2 – Plot 3

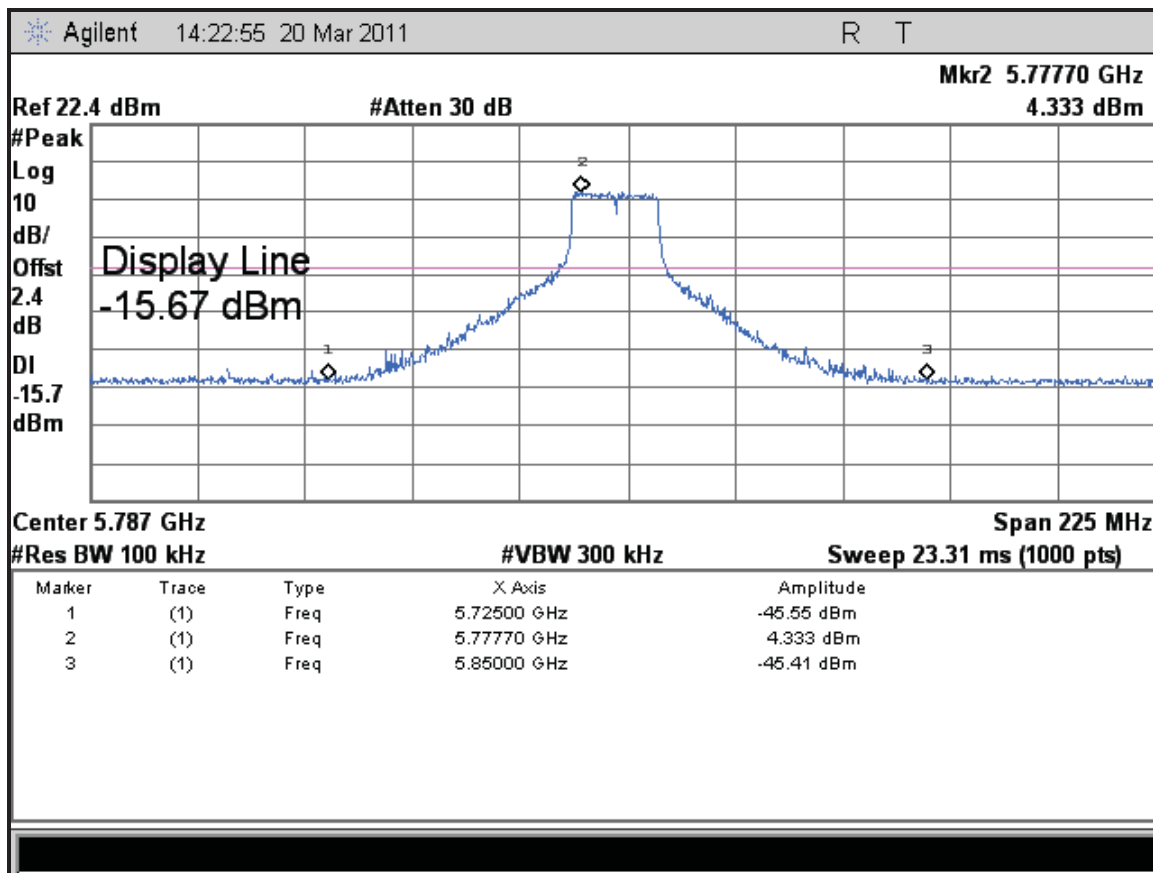
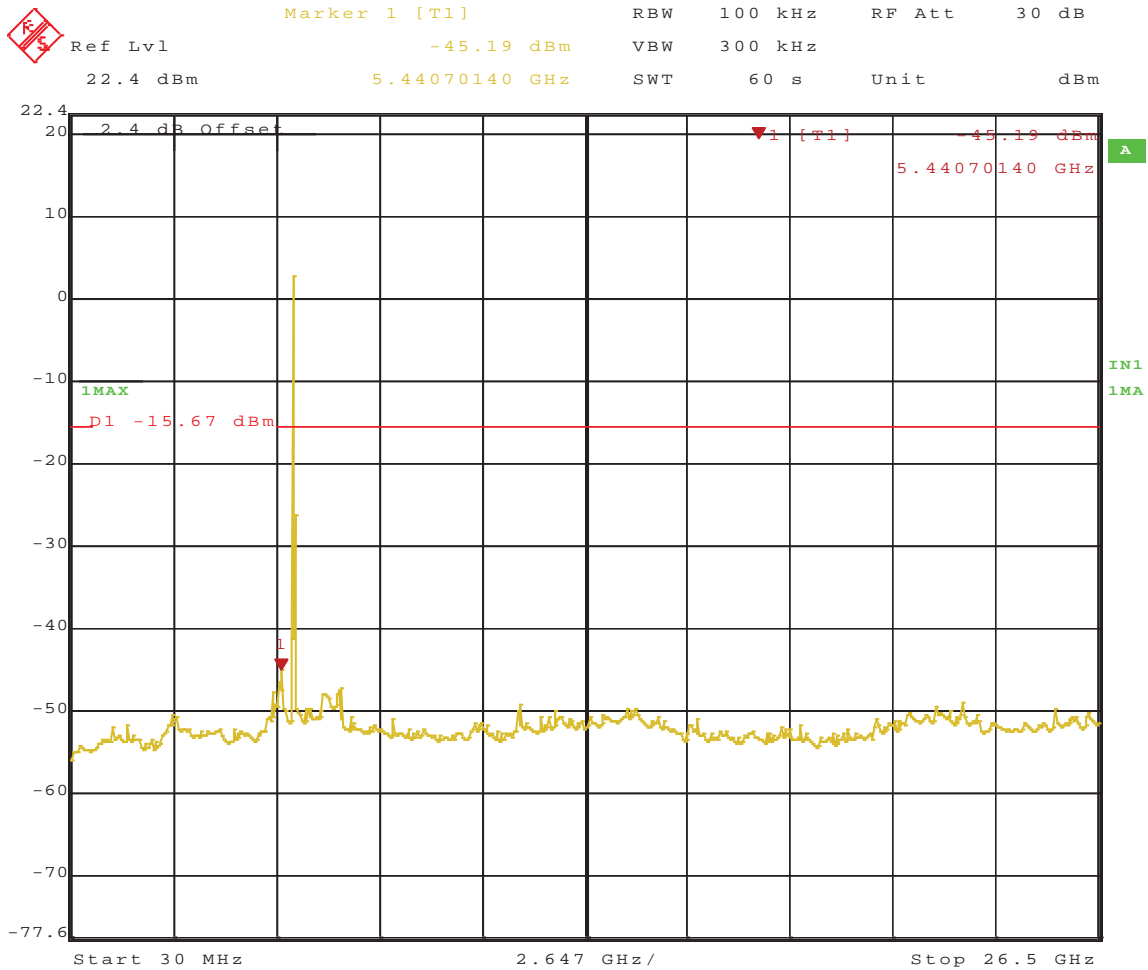
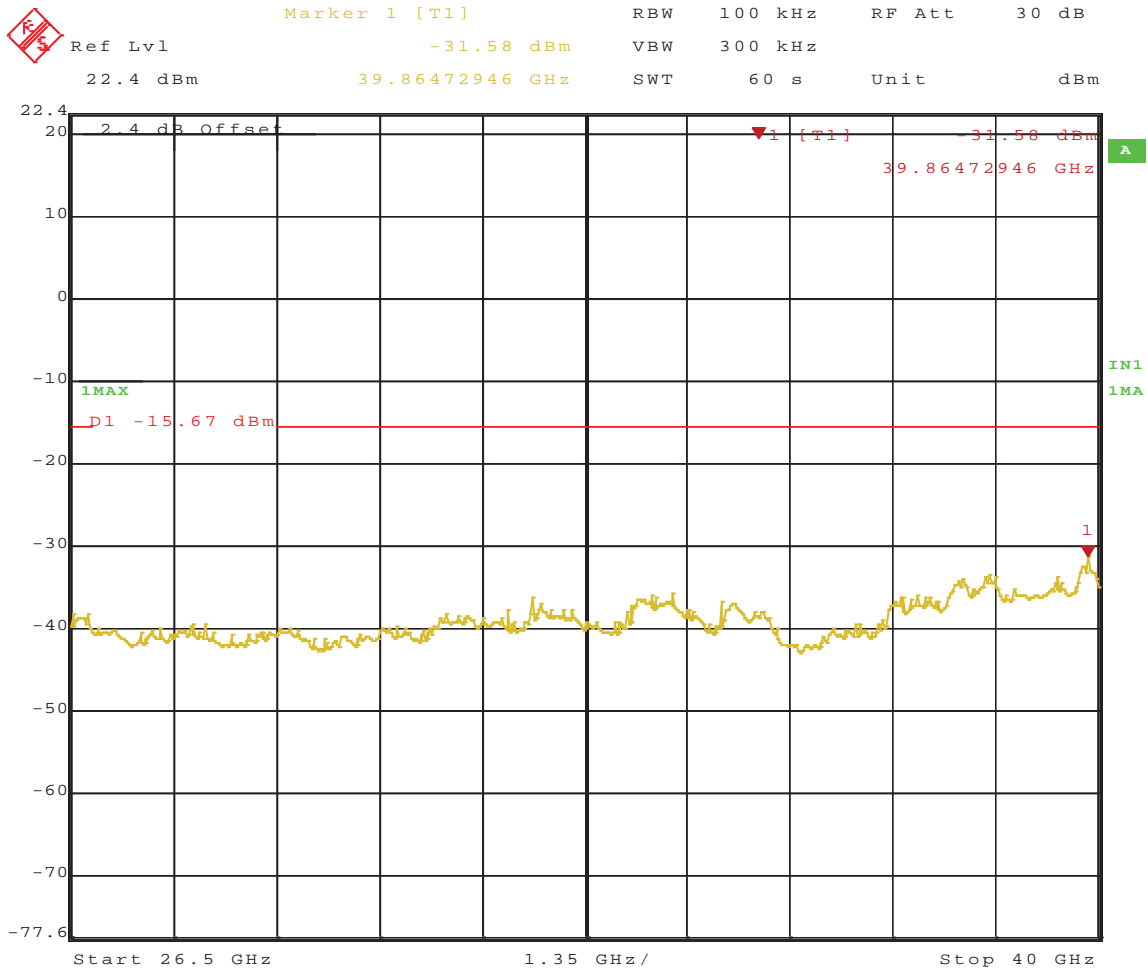

Figure 494: Band-edge Requirement at 802.11n HT20, 6.5 Mbps 5785 MHz, Chain 2 – Plot 1



Date: 22.MAR.2011 15:21:24

Figure 495: Out of Band at 802.11n HT20, 6.5 Mbps 5785 MHz, Chain 2 – Plot 2



Date: 22.MAR.2011 15:22:59

Figure 496: Out of Band at 802.11n HT20, 6.5 Mbps 5785 MHz, Chain 2 – Plot 3

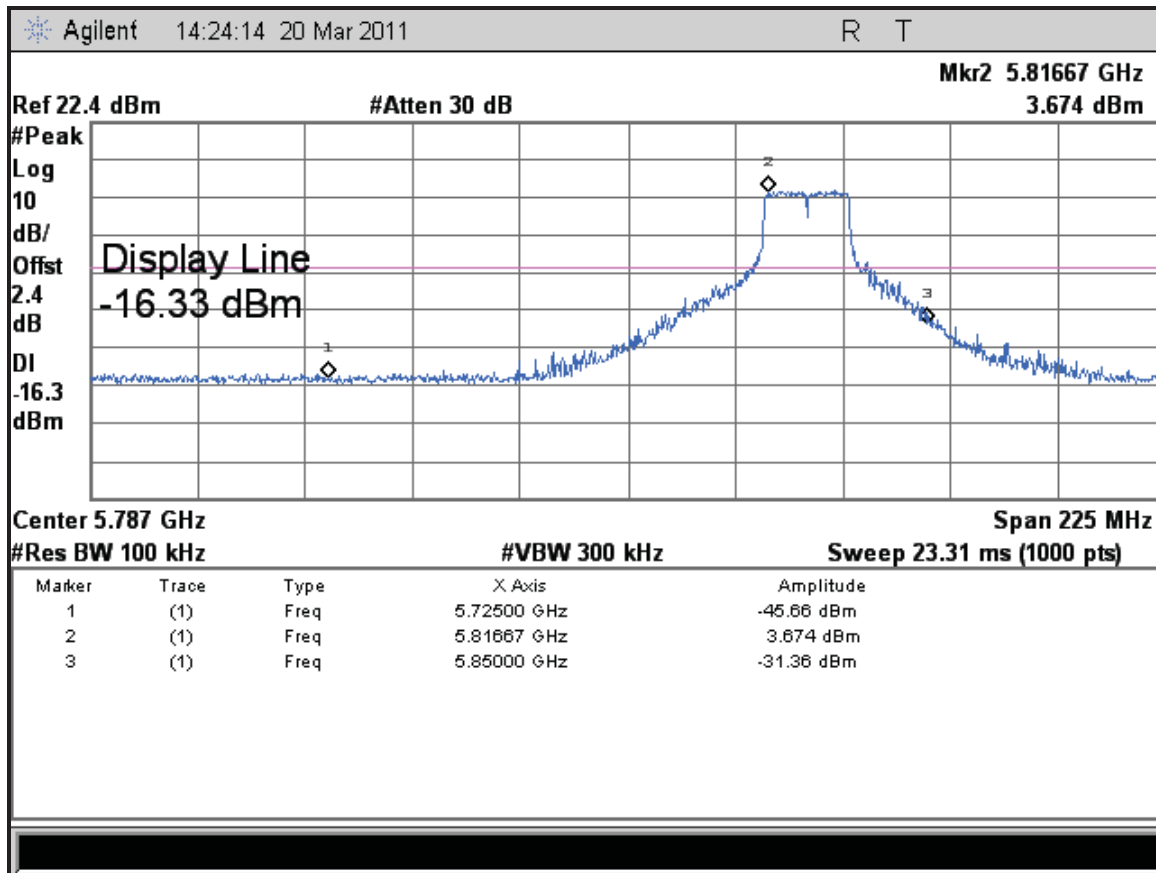
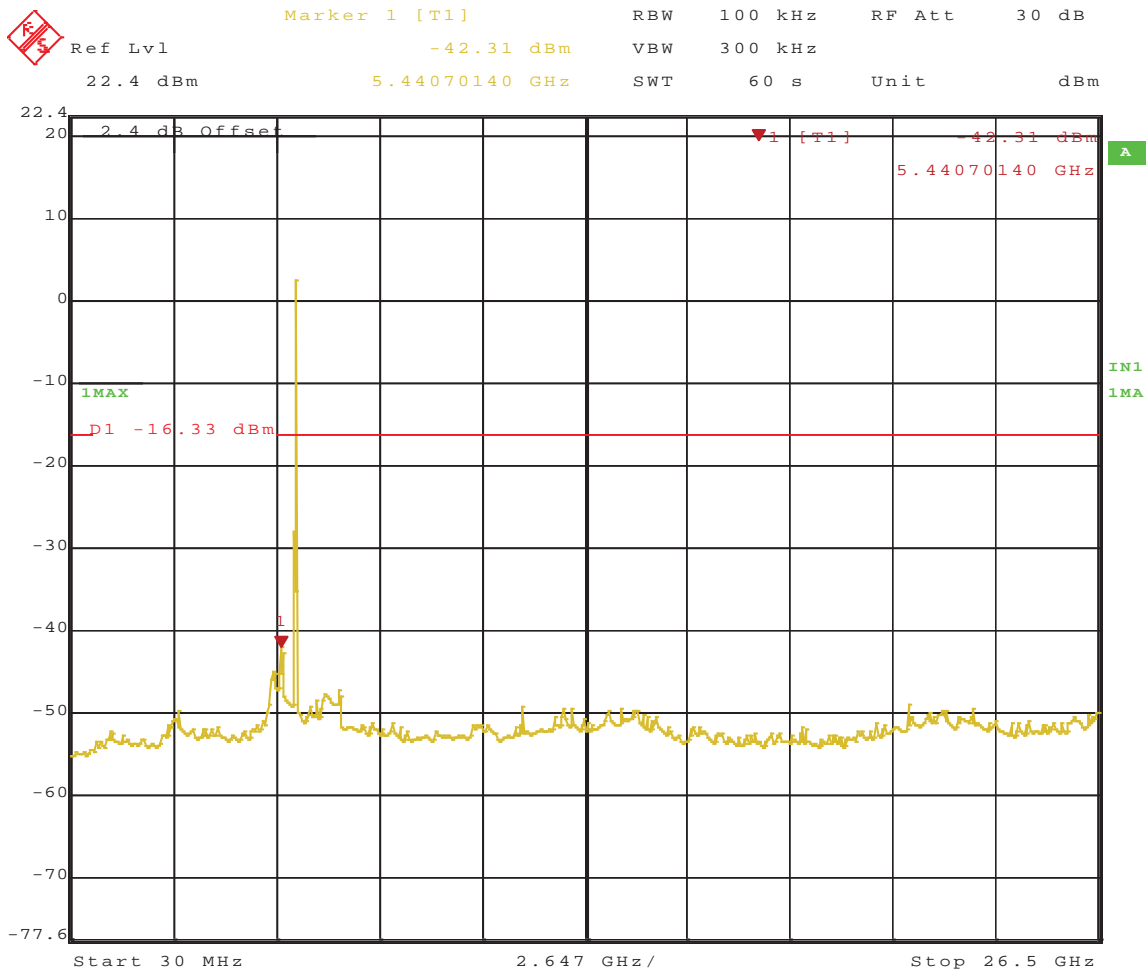
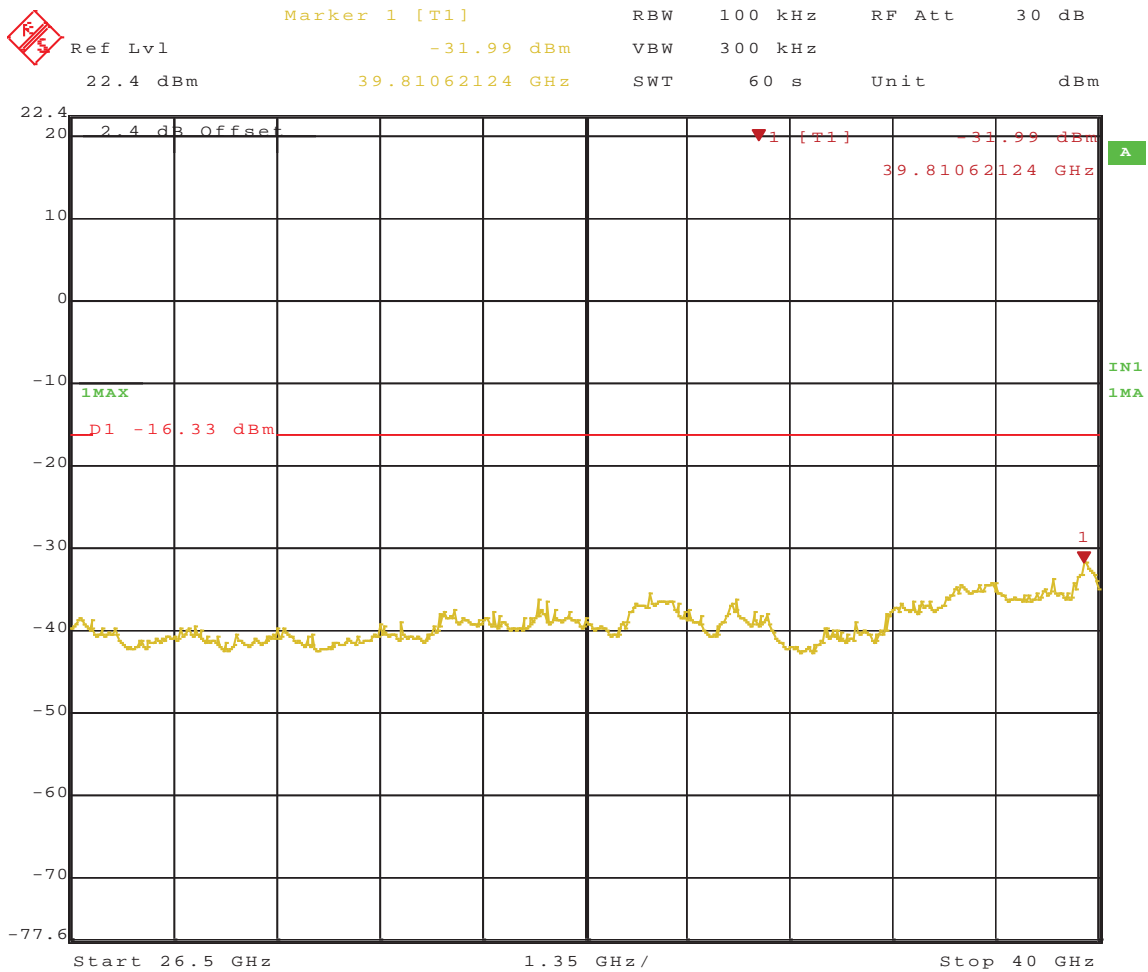

Figure 497: Band-edge Requirement at 802.11n HT20, 6.5 Mbps 5825 MHz, Chain 2 – Plot 1



Date: 22.MAR.2011 15:26:50

Figure 498: Out of Band at 802.11n HT20, 6.5 Mbps 5825 MHz, Chain 2 – Plot 2



Date: 22.MAR.2011 15:25:05

Figure 499: Out of Band at 802.11n HT20, 6.5 Mbps 5825 MHz, Chain 2 – Plot 3

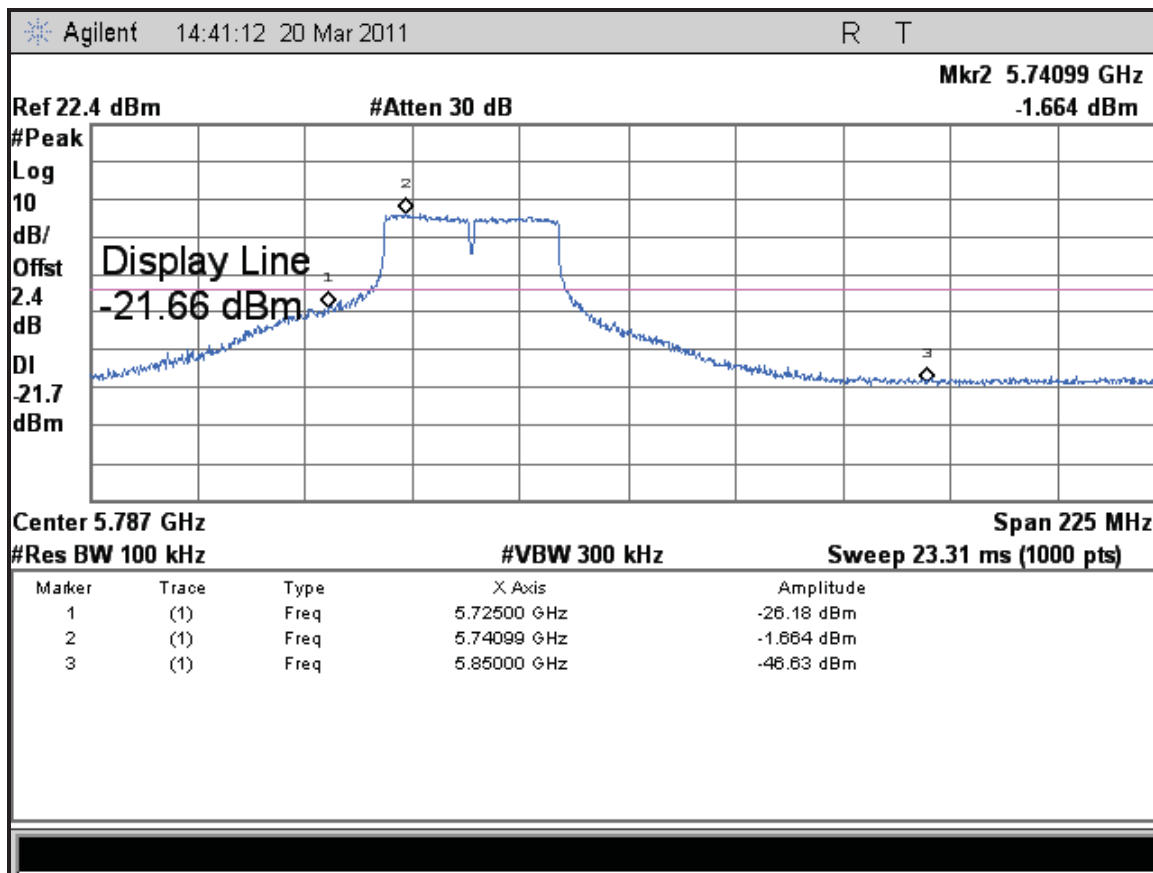
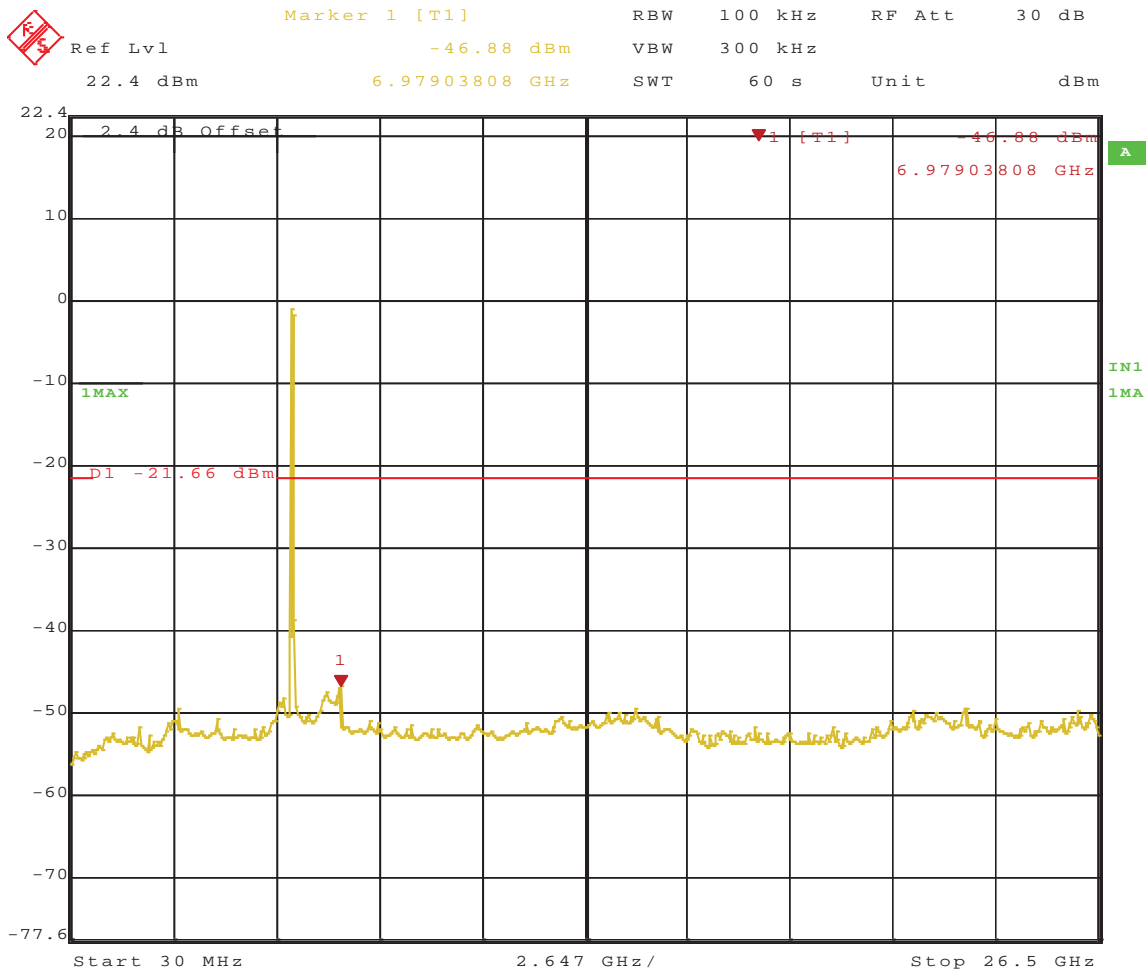
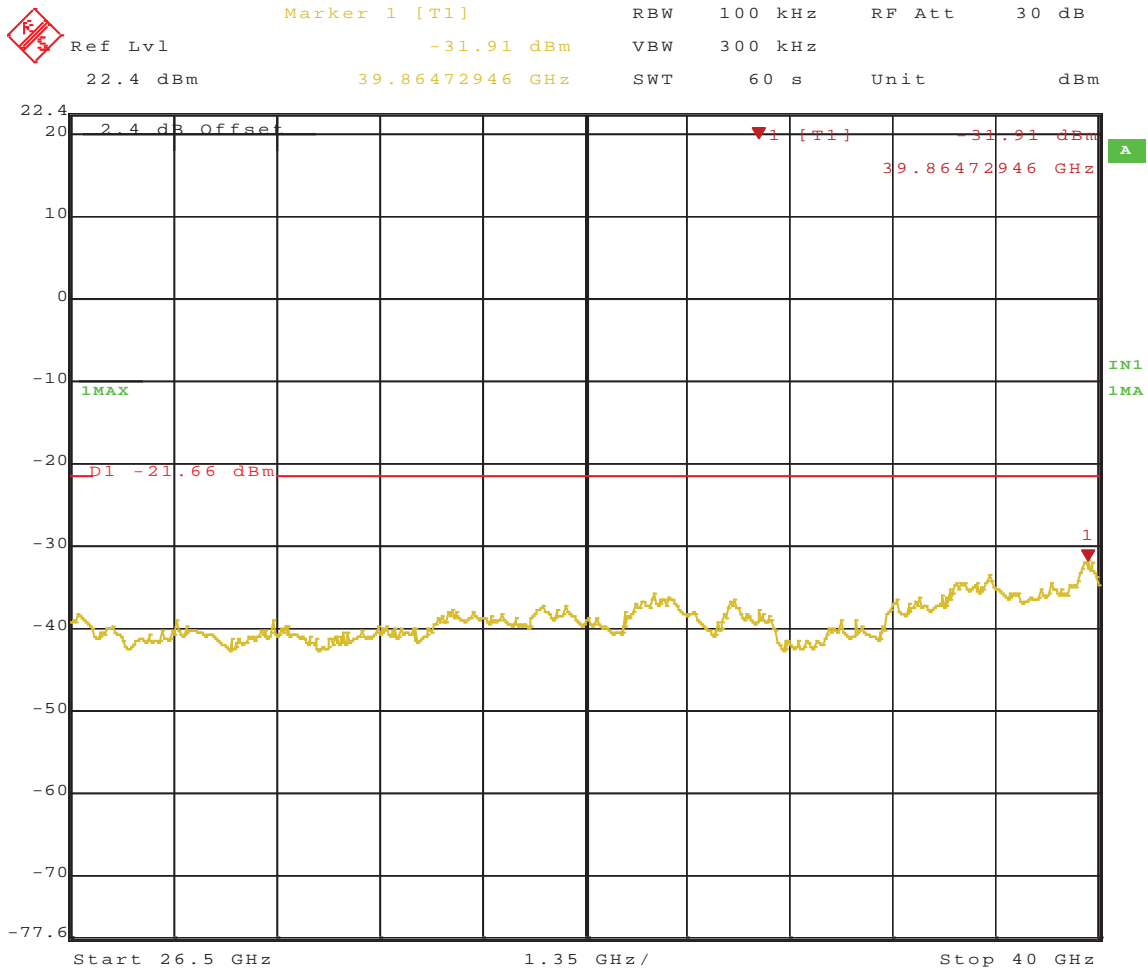

Figure 500: Band-edge Requirement at 802.11n HT40, 13.5 Mbps 5755 MHz, Chain 0 – Plot 1



Date: 22.MAR.2011 15:30:25

Figure 501: Out of Band at 802.11n HT40, 13.5 Mbps 5755 MHz, Chain 0 – Plot 2



Date: 22.MAR.2011 15:32:35

Figure 502: Out of Band at 802.11n HT40, 13.5 Mbps 5755 MHz, Chain 0 – Plot 3

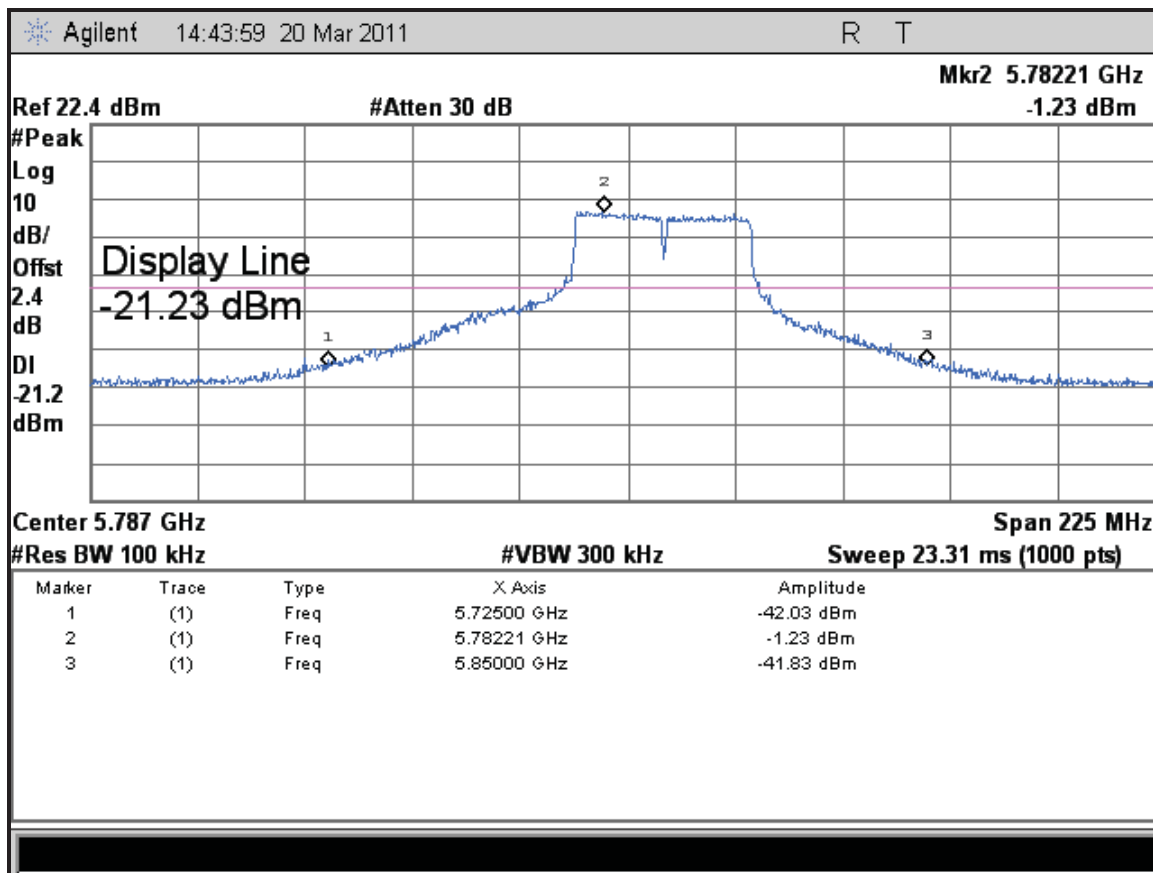
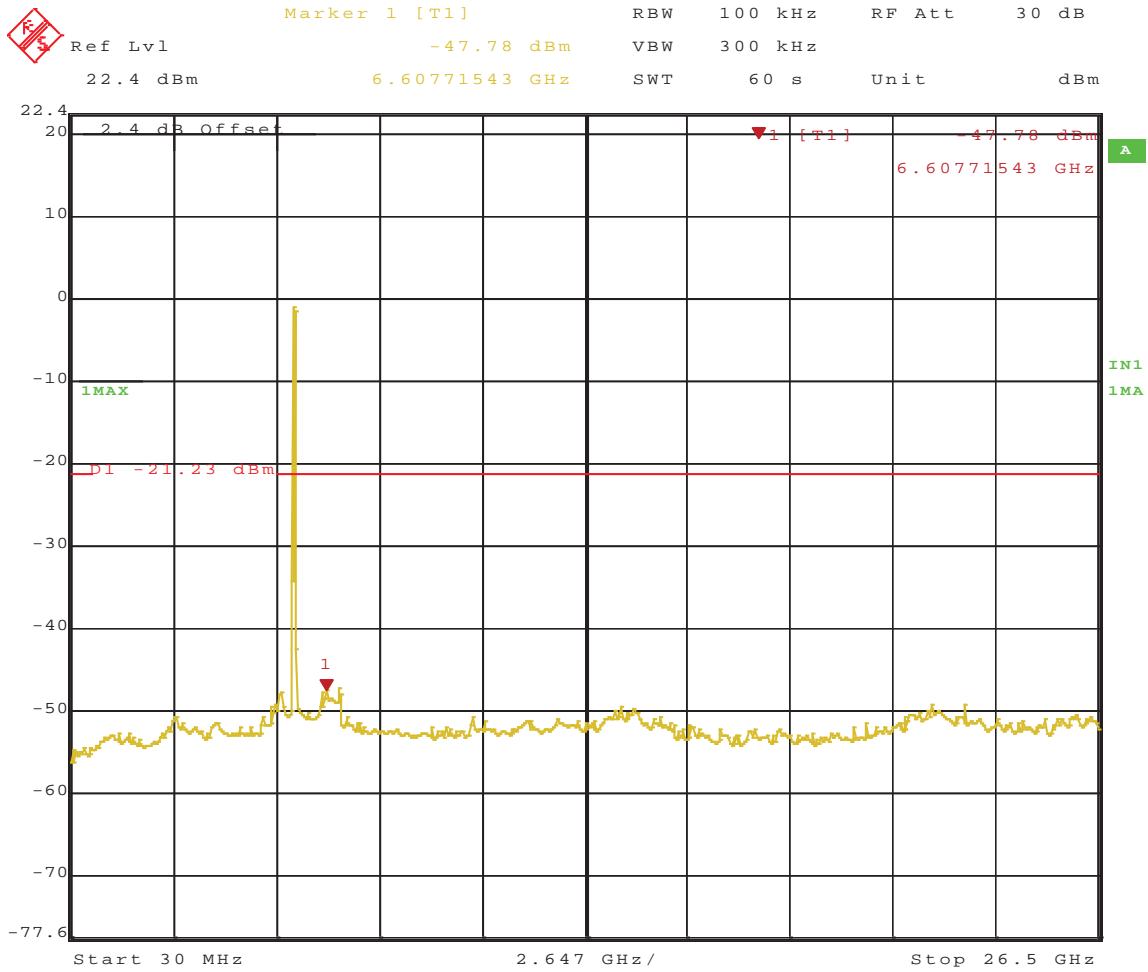
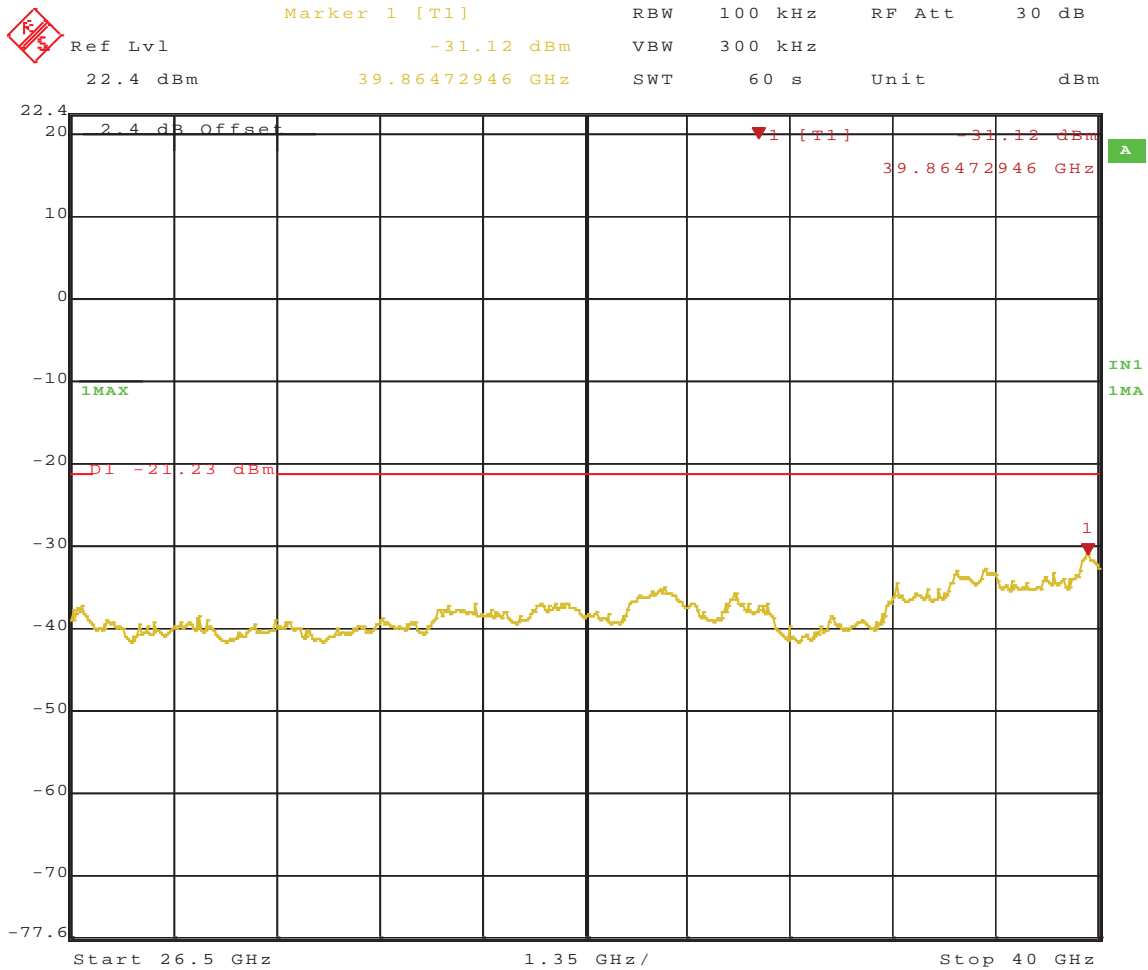

Figure 503: Band-edge Requirement at 802.11n HT40, 13.5 Mbps 5795 MHz, Chain 0 – Plot 1



Date: 22.MAR.2011 15:59:23

Figure 504: Out of Band at 802.11n HT40, 13.5 Mbps 5795 MHz, Chain 0 – Plot 2



Date: 22.MAR.2011 15:57:27

Figure 505: Out of Band at 802.11n HT40, 13.5 Mbps 5795 MHz, Chain 0 – Plot 3

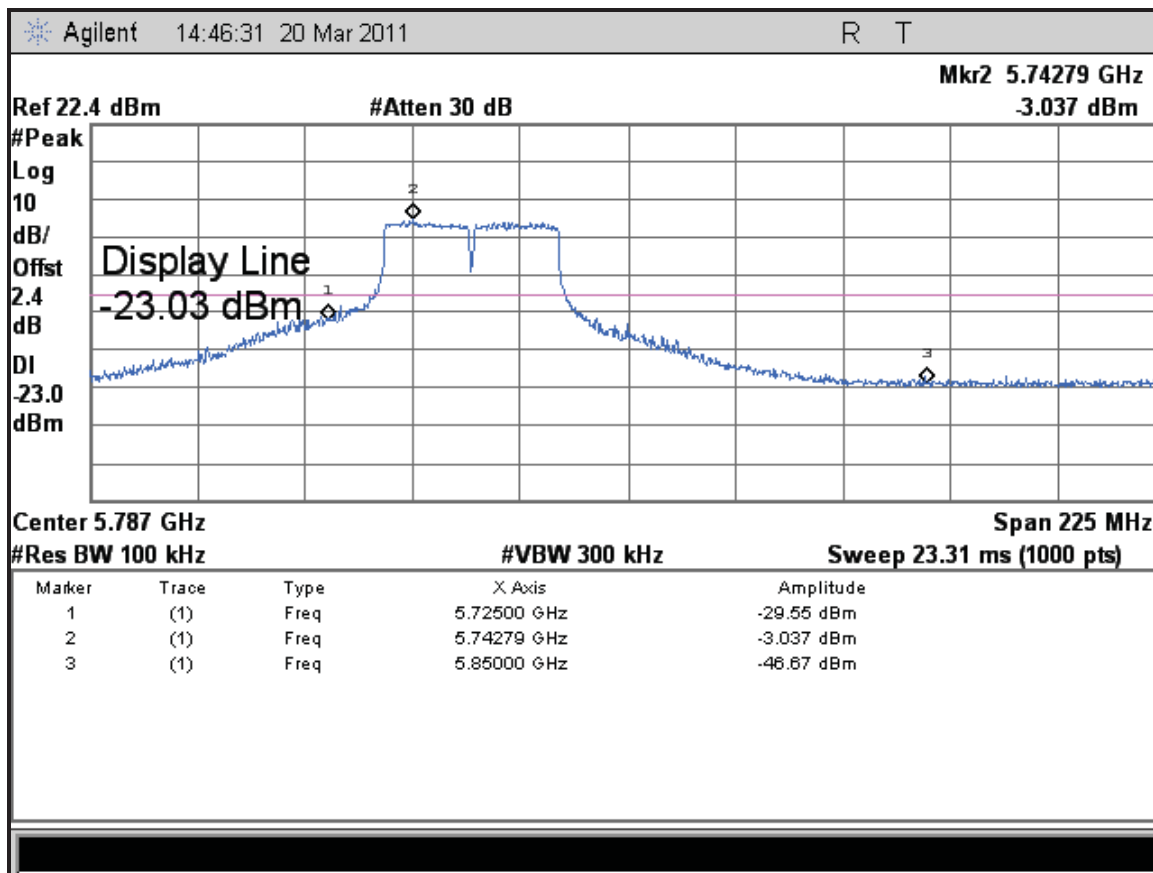
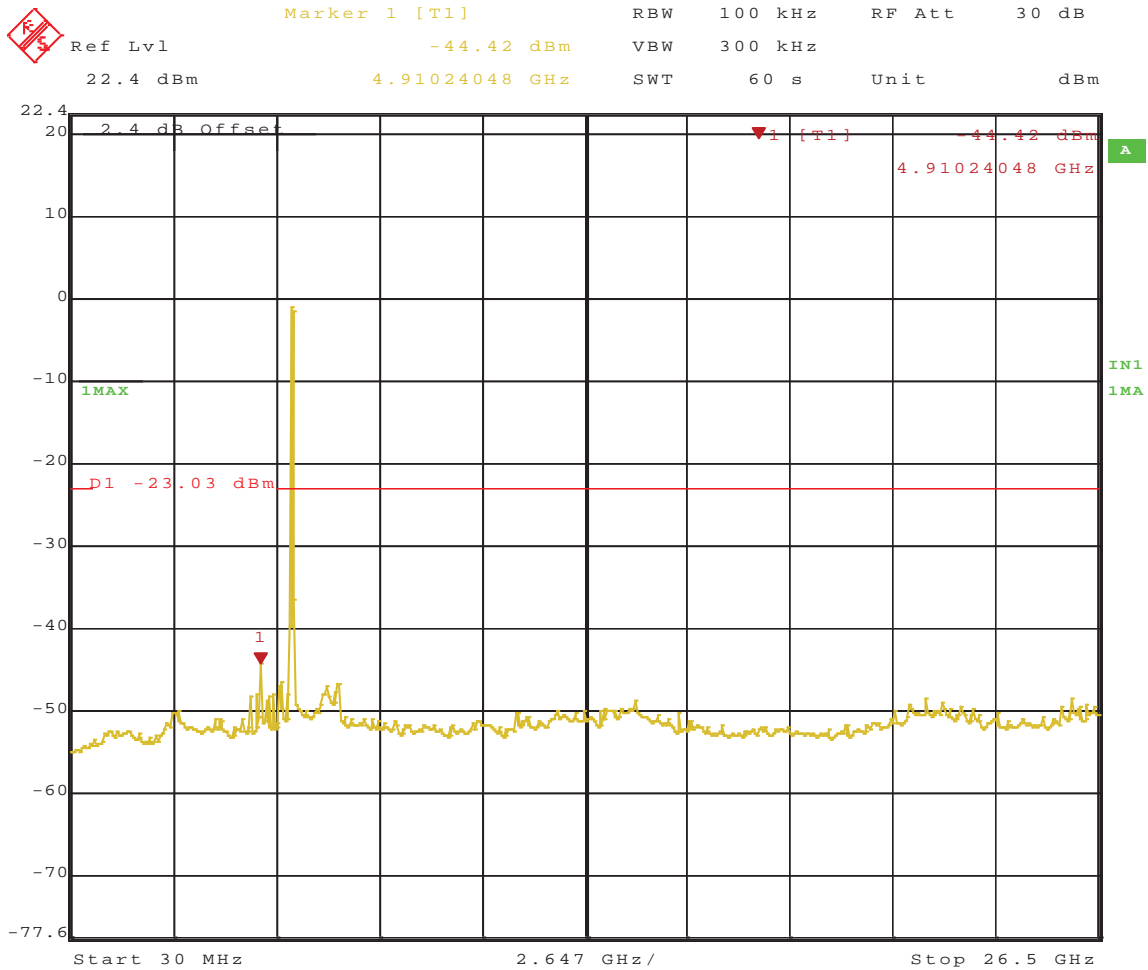
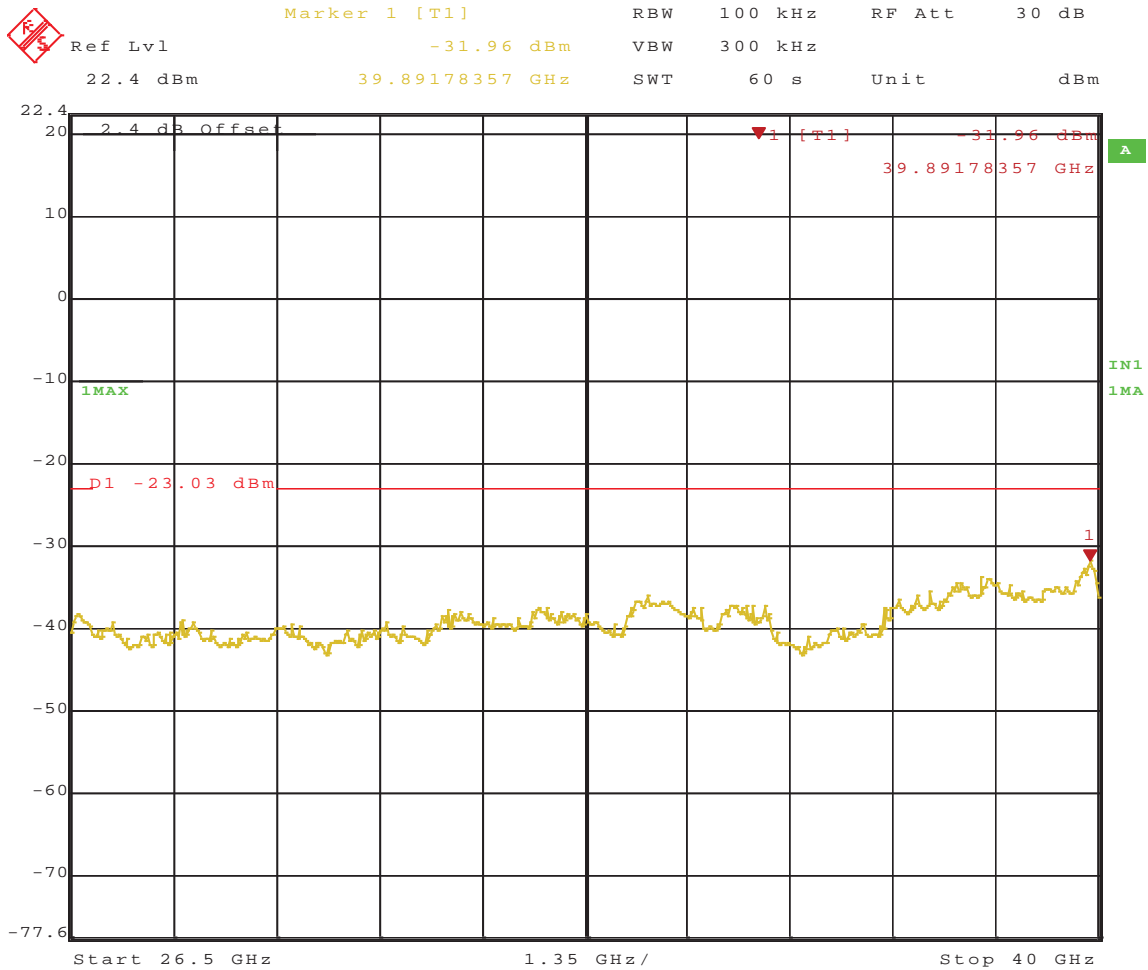

Figure 506: Band-edge Requirement at 802.11n HT40, 13.5 Mbps 5755 MHz, Chain 1 – Plot 1



Date: 22.MAR.2011 16:08:31

Figure 507: Out of Band at 802.11n HT40, 13.5 Mbps 5755 MHz, Chain 1 – Plot 2



Date: 22.MAR.2011 16:10:14

Figure 508: Out of Band at 802.11n HT40, 13.5 Mbps 5755 MHz, Chain 1 – Plot 3

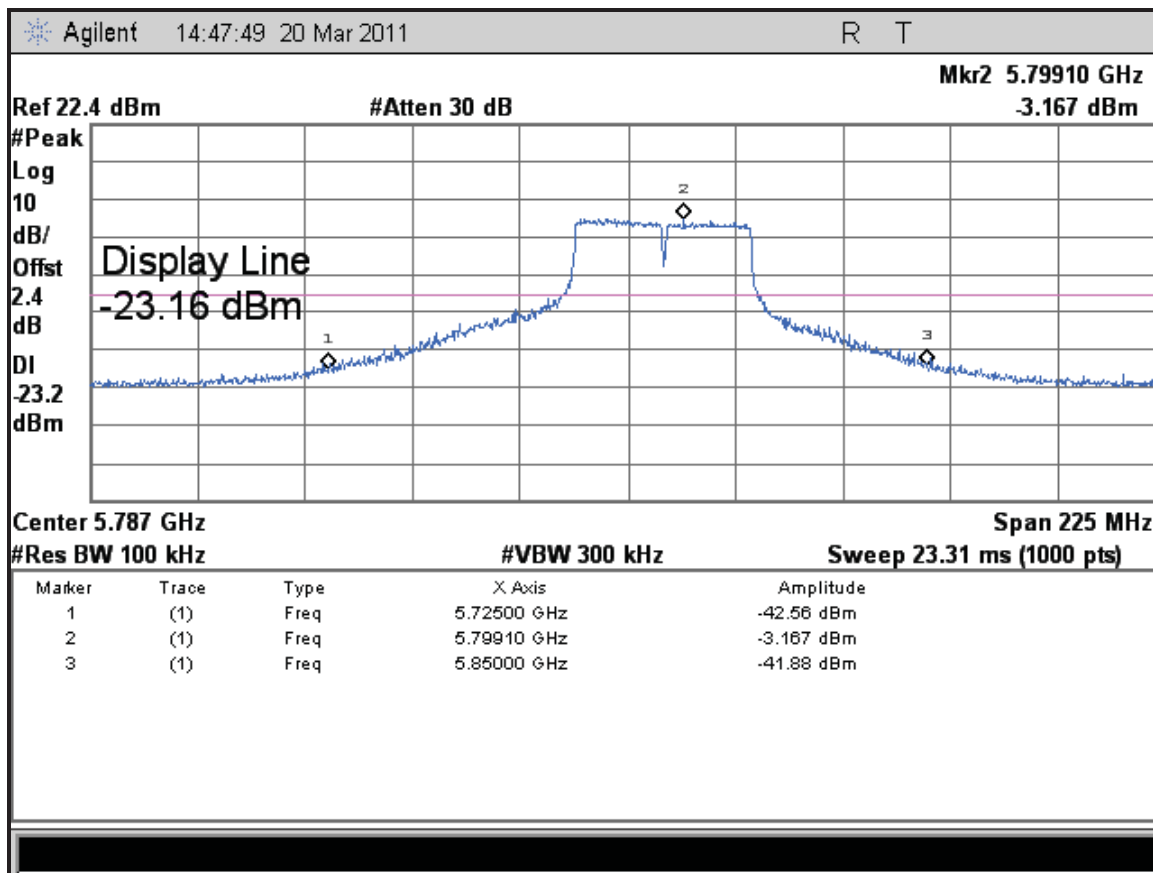

Figure 509: Band-edge Requirement at 802.11n HT40, 13.5 Mbps 5795 MHz, Chain 1 – Plot 1