

RF TEST REPORT



Report No.: 15070962-FCC-R5

Supersede Report No.: N/A

Applicant	Verykool USA Inc	
Product Name	Mobile phone	
Model No.	SL6010	
Serial No.	N/A	
Test Standard	FCC Part 22(H), FCC Part 24(E), FCC Part 27: 2014; ANSI/TIA C603 D: 2010	
Test Date	October 27 to November 18, 2015	
Issue Date	November 18, 2015	
Test Result	<input checked="" type="checkbox"/> Pass <input type="checkbox"/> Fail	
Equipment complied with the specification	<input checked="" type="checkbox"/>	
Equipment did not comply with the specification	<input type="checkbox"/>	
<i>Winnie Zhang</i>	<i>David Huang</i>	
Winnie Zhang Test Engineer	David Huang Checked By	
This test report may be reproduced in full only Test result presented in this test report is applicable to the tested sample only		

Issued by:

SIEMIC (SHENZHEN-CHINA) LABORATORIES

Zone A, Floor 1, Building 2 Wan Ye Long Technology Park

South Side of Zhoushi Road, Bao' an District, Shenzhen, Guangdong China 518108

Phone: +86 0755 2601 4629801 Email: China@siemic.com.cn

Laboratories Introduction

SIEMIC, headquartered in the heart of Silicon Valley, with superior facilities in US and Asia, is one of the leading independent testing and certification facilities providing customers with one-stop shop services for Compliance Testing and Global Certifications.



In addition to testing and certification, SIEMIC provides initial design reviews and compliance management throughout a project. Our extensive experience with China, Asia Pacific, North America, European, and International compliance requirements, assures the fastest, most cost effective way to attain regulatory compliance for the global markets.

Accreditations for Conformity Assessment

Country/Region	Scope
USA	EMC, RF/Wireless, SAR, Telecom
Canada	EMC, RF/Wireless, SAR, Telecom
Taiwan	EMC, RF, Telecom, SAR, Safety
Hong Kong	RF/Wireless, SAR, Telecom
Australia	EMC, RF, Telecom, SAR, Safety
Korea	EMI, EMS, RF, SAR, Telecom, Safety
Japan	EMI, RF/Wireless, SAR, Telecom
Singapore	EMC, RF, SAR, Telecom
Europe	EMC, RF, SAR, Telecom, Safety

Test Report	15070962-FCC-R5
Page	3 of 133

This page has been left blank intentionally.

CONTENTS

1. REPORT REVISION HISTORY	5
2. CUSTOMER INFORMATION	5
3. TEST SITE INFORMATION.....	5
4. EQUIPMENT UNDER TEST (EUT) INFORMATION.....	6
5. TEST SUMMARY	9
6. MEASUREMENTS, EXAMINATION AND DERIVED RESULTS	10
6.1 RF EXPOSURE (SAR).....	10
6.2 RF OUTPUT POWER.....	11
6.3 PEAK-AVERAGE RATIO.....	46
6.4 MODULATION CHARACTERISTIC.....	49
6.5 OCCUPIED BANDWIDTH.....	50
6.6 SPURIOUS EMISSIONS AT ANTENNA TERMINALS.....	78
6.7 SPURIOUS RADIATED EMISSIONS.....	84
6.8 BAND EDGE.....	91
6.9 BAND EDGE 27.53(M).....	111
6.10 FREQUENCY STABILITY.....	117
ANNEX A. TEST INSTRUMENT.....	122
ANNEX B. EUT AND TEST SETUP PHOTOGRAPHS.....	123
ANNEX C. TEST SETUP AND SUPPORTING EQUIPMENT.....	129
ANNEX C.II. EUT OPERATING CONKITIONS	131
ANNEX D. USER MANUAL / BLOCK DIAGRAM / SCHEMATICS / PARTLIST	132
ANNEX E. DECLARATION OF SIMILARITY.....	133

1. Report Revision History

Report No.	Report Version	Description	Issue Date
15070962-FCC-R5	NONE	Original	November 18, 2015

2. Customer information

Applicant Name	Verykool USA Inc
Applicant Add	3636 Nobel Drive, Suite 325, San Diego, CA 92122 USA
Manufacturer	HUIZHOU QIAOXING ELECTRONICS TECHNOLOGY CO.,LTD
Manufacturer Add	Room 1906 of VIA Building, No.9966 Shennan Avenue, Yuehai Street in Nanshan District, Shenzhen

3. Test site information

Lab performing tests	SIEMIC (Shenzhen-China) LABORATORIES
Lab Address	Zone A, Floor 1, Building 2 Wan Ye Long Technology Park South Side of Zhoushi Road, Bao' an District, Shenzhen, Guangdong China 518108
FCC Test Site No.	718246
IC Test Site No.	4842E-1
Test Software	Radiated Emission Program-To Shenzhen v2.0

4. Equipment under Test (EUT) Information

Description of EUT:	Mobile phone
Main Model:	SL6010
Serial Model:	N/A
Date EUT received:	October 26, 2015
Test Date(s):	October 27 to November 18, 2015
Equipment Category :	PCE
Antenna Gain:	GSM850: 1.7 dBi PCS1900: 3.7 dBi UMTS-FDD Band V: 1.7 dBi UMTS-FDD Band IV: 3.6 dBi UMTS-FDD Band II: 3.7 dBi Bluetooth/BLE: 3.0 dBi WIFI: 2.8 dBi LTE Band 2: 3.7 dBi LTE Band 4: 3.6 dBi LTE Band 5: 1.7 dBi LTE Band 7: 2.8 dBi LTE Band 17: 1.7 dBi GPS:1.8 dBi
Type of Modulation:	GSM / GPRS: GMSK EGPRS: GMSK,8PSK UMTS-FDD: QPSK, 16QAM 802.11b/g/n: DSSS, OFDM Bluetooth: GFSK, π /4DQPSK, 8DPSK BLE: GFSK LTE Band: QPSK, 16QAM GPS:BPSK

	<p>GSM850 TX: 824.2 ~ 848.8 MHz; RX: 869.2 ~ 893.8 MHz PCS1900 TX: 1850.2 ~ 1909.8 MHz; RX: 1930.2 ~ 1989.8 MHz UMTS-FDD Band V TX: 826.4 ~ 846.6 MHz; RX: 871.4 ~ 891.6 MHz UMTS-FDD Band IV TX:1712.4 ~ 1752.6 MHz; RX : 2112.4 ~ 2152.6 MHz UMTS-FDD Band II TX:1852.4 ~ 1907.6 MHz; RX: 1932.4 ~ 1987.6 MHz WIFI:802.11b/g/n(20M): 2412-2462 MHz WIFI:802.11n(40M): 2422-2472 MHz Bluetooth& BLE: 2402-2480 MHz LTE Band 2 TX: 1852.5 ~ 1907.5 MHz; RX : 1932.5 ~ 1987.5 MHz LTE Band 4 TX: 1712.5 ~ 1752.5 MHz; RX : 2112.5 ~ 2152.5 MHz LTE Band 5 TX: 826.5 ~ 846.5 MHz; RX : 871.5 ~ 891.5 MHz LTE Band 7 TX: 2502.5 ~ 2567.5 MHz; RX : 2622.5 ~ 2687.5 MHz LTE Band 12 TX:699.7 ~ 715.3 MHz; RX : 729.7~ 745.3MHz LTE Band 17 TX: 706.5 ~ 713.5 MHz; RX : 736.5 ~ 743.5 MHz GPS RX:1575.42 MHz</p>
RF Operating Frequency (ies):	
Maximum Conducted AV Power to Antenna:	<p>LTE Band 2: 23.69dBm LTE Band 4: 23.28dBm LTE Band 5: 23.63dBm LTE Band 7: 22.49 dBm LTE Band 17: 23.86 dBm</p>
ERP/EIRP:	<p>LTE Band 2: 26.88 dBm / EIRP LTE Band 4: 26.38 dBm / EIRP LTE Band 5: 25.02 dBm / EIRP LTE Band 7: 25.86 dBm / EIRP LTE Band 17: 25.43dBm / ERP</p>
Port:	Power Port, Earphone Port, USB Port
Input Power:	<p>Adapter: Model:STC-A515A-Z Input: AC 100-240V; 50/60Hz; 300mA Output: DC 5.0V,1500mA Battery: Model:Q600 Spec:3.7V,2500mAh(9.25Wh) Limited charger voltage:4.2V</p>

Test Report	15070962-FCC-R5
Page	8 of 133

Trade Name : verykool

GPRS/EGPRS Multi-slot class 8/10/12

FCC ID: WA6SL6010

5. Test Summary

The product was tested in accordance with the following specifications.

All testing has been performed according to below product classification:

FCC Rules	Description of Test	Result
§ 1.1307; § 2.1093	RF Exposure (SAR)	Compliance
§2.1046; § 22.913(a); § 24.232(c); § 27.50(c.10); § 27.50(d.4)	RF Output Power	Compliance
§ 24.232 (d); § 27.50(d)	Peak-Average Ratio	Compliance
§ 2.1047	Modulation Characteristics	Compliance
§ 2.1049; § 22.905; § 22.917; § 24.238; § 27.53(a.5)	99% & -26 dB Occupied Bandwidth	Compliance
§ 2.1051; § 22.917(a); § 24.238(a); § 27.53(h)	Spurious Emissions at Antenna Terminal	Compliance
§ 2.1053; § 22.917(a); § 24.238(a); § 27.53(h)	Field Strength of Spurious Radiation	Compliance
§ 22.917(a); § 24.238(a);	Out of band emission, Band Edge	Compliance
§ 27.53(m)	Band Edge 27.53(m)	Compliance
§ 2.1055; § 22.355; § 24.235; § 27.5(h); § 27.54	Frequency stability vs. temperature Frequency stability vs. voltage	Compliance

Note: Testing was performed by configuring EUT to maximum output power status, the declared output power class for different

Measurement Uncertainty

Emissions		
Test Item	Description	Uncertainty
Band Edge and Radiated Spurious Emissions	Confidence level of approximately 95% (in the case where distributions are normal), with a coverage factor of 2 (for EUTs < 0.5m X 0.5m X 0.5m)	+5.6dB/-4.5dB
-	-	-

6. MEASUREMENTS, EXAMINATION AND DERIVED RESULTS

6.1 RF Exposure (SAR)

Test Result: Pass

The EUT is a portable device, thus requires SAR evaluation;

Please refer to RF Exposure Evaluation Report: 15070962-FCC-H.

6.2 RF Output Power

Temperature	22°C
Relative Humidity	57%
Atmospheric Pressure	1005mbar
Test date :	November 05, 2015
Tested By :	Winnie Zhang

Requirement(s):

Spec	Item	Requirement	Applicable
§22.913 (a)	a)	ERP:38.45dBm	<input checked="" type="checkbox"/>
§24.232 (c)	b)	EIRP:33dBm	<input checked="" type="checkbox"/>
§27.50 (c)	c)	EIRP: 30dBm	<input checked="" type="checkbox"/>

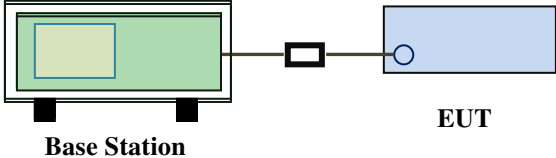
Test Setup	 <p>The diagram illustrates the test setup. On the left is a green rectangular box labeled 'Base Station'. A black cable connects it to a blue rectangular box on the right labeled 'EUT'. The connection point on the EUT is marked with a small circle.</p>
------------	--------------------------------------------------------------------------------------------------------------------------------------------------------------------------------------------------------------------------------------------------------------------------------------------------------------------------------------------------

Test Procedure	<p>For Conducted Power:</p> <ul style="list-style-type: none"> - The transmitter output port was connected to base station. - Set EUT at maximum power through base station. - Select lowest, middle, and highest channels for each band and different test mode. <p>For ERP/EIRP:</p> <ul style="list-style-type: none"> - The transmitter was placed on a wooden turntable, and it was transmitting into a non-radiating load which was also placed on the turntable. - The measurement antenna was placed at a distance of 3 meters from the EUT. During the tests, the antenna height and polarization as well as EUT azimuth were varied in order to identify the maximum level of emissions from the EUT. The test was performed by placing the EUT on 3-orthogonal axis. - The frequency range up to tenth harmonic of the fundamental frequency was investigated.
----------------	---------------------------------------------------------------------------------------------------------------------------------------------------------------------------------------------------------------------------------------------------------------------------------------------------------------------------------------------------------------------------------------------------------------------------------------------------------------------------------------------------------------------------------------------------------------------------------------------------------------------------------------------------------------------------------------------------------------------------------------------------------------------------------------------------------------------------------------------------------------------------------------------------------------------------------------------

Test Report	15070962-FCC-R5
Page	12 of 133

	<ul style="list-style-type: none"> - Remove the EUT and replace it with substitution antenna. A signal generator was connected to the substitution antenna by a non-radiating cable. The absolute levels of the spurious emissions were measured by the substitution. - Spurious emissions in dB = 10 log (TX power in Watts/0.001) – the absolute level - Spurious attenuation limit in dB = 43 + 10 Log10 (power out in Watts).
Remark	
Result	<input checked="" type="checkbox"/> Pass <input type="checkbox"/> Fail

Test Data Yes N/A
Test Plot Yes (See below) N/A

Conducted Power

LTE Band 2:

BW (MHz)	Ch	Freq. (MHz)	Mode	UL RB Allocation	UL RB Offset	MPR	Average power (dBm)	Tune up Power tolerant
20MHz	18700	1860.0	QPSK	1	0	0	23.24	23±1
				1	49	0	23.26	23±1
				1	99	0	23.25	23±1
				50	0	1	22.43	23±1
				50	24	1	22.45	23±1
				50	49	1	22.46	23±1
			100	0	1	22.49	23±1	
			16QAM	1	0	1	22.70	22±1
				1	49	1	22.68	22±1
				1	99	1	22.63	22±1
				50	0	2	22.35	22±1
				50	24	2	22.36	22±1
				50	49	2	22.31	22±1
				100	0	2	21.61	22±1
	18900	1880.0		QPSK	1	0	0	23.56
			1		49	0	23.52	23±1
			1		99	0	23.51	23±1
			50		0	1	22.44	23±1
			50		24	1	22.46	23±1
			50		49	1	22.41	23±1
			100	0	1	22.43	23±1	
			16QAM	1	0	1	22.39	22±1
				1	49	1	22.31	22±1
				1	99	1	22.38	22±1
				50	0	2	21.82	22±1
				50	24	2	21.82	22±1
	50	49		2	21.86	22±1		
	100	0	2	21.50	22±1			
	19100	1900.0	QPSK	1	0	0	22.81	22±1
				1	49	0	22.86	22±1
1				99	0	22.84	22±1	
50				0	1	22.23	22±1	
50				24	1	22.26	22±1	
50				49	1	22.29	22±1	
100				0	1	22.43	22±1	
16QAM			1	0	1	22.30	22±1	
			1	49	1	22.35	22±1	
			1	99	1	22.31	22±1	
			50	0	2	21.76	22±1	
			50	24	2	21.74	22±1	
			50	49	2	21.75	22±1	
			100	0	2	21.41	22±1	

BW (MHz)	Ch	Freq. (MHz)	Mode	UL RB Allocation	UL RB Offset	MPR	Average power (dBm)	Tune up Power tolerant
15MHz	18675	1857.5	QPSK	1	0	0	23.53	23±1
				1	37	0	23.56	23±1
				1	74	0	23.54	23±1
				36	0	1	22.66	23±1
				36	16	1	22.63	23±1
				36	35	1	22.68	23±1
				75	0	1	22.70	23±1
			16QAM	1	0	1	22.88	22±1
				1	37	1	22.83	22±1
				1	74	1	22.85	22±1
				36	0	2	22.35	22±1
				36	16	2	22.39	22±1
				36	35	2	22.34	22±1
				75	0	2	21.72	22±1
	18900	1880.0	QPSK	1	0	0	23.58	23±1
				1	37	0	23.53	23±1
				1	74	0	23.54	23±1
				36	0	1	22.61	23±1
				36	16	1	22.63	23±1
				36	35	1	22.65	23±1
				75	0	1	22.51	23±1
			16QAM	1	0	1	22.30	22±1
				1	37	1	22.35	22±1
				1	74	1	22.34	22±1
				36	0	2	21.86	22±1
				36	16	2	21.82	22±1
				36	35	2	21.85	22±1
				75	0	2	21.64	22±1
	19125	1902.5	QPSK	1	0	0	22.88	22±1
				1	37	0	22.86	22±1
				1	74	0	22.83	22±1
				36	0	1	22.12	22±1
				36	16	1	22.15	22±1
				36	35	1	22.18	22±1
				75	0	1	22.25	22±1
			16QAM	1	0	1	22.12	22±1
1				37	1	22.16	22±1	
1				74	1	22.13	22±1	
36				0	2	21.68	22±1	
36				16	2	21.67	22±1	
36				35	2	21.69	22±1	
75				0	2	21.43	22±1	

BW (MHz)	Ch	Freq. (MHz)	Mode	UL RB Allocation	UL RB Offset	MPR	Average power (dBm)	Tune up Power tolerant
10MHz	18650	1855	QPSK	1	0	0	23.53	23±1
				1	24	0	23.56	23±1
				1	49	0	23.54	23±1
				25	0	1	22.51	23±1
				25	12	1	22.53	23±1
				25	24	1	22.56	23±1
				50	0	1	22.53	23±1
			16QAM	1	0	1	22.90	22±1
				1	24	1	22.96	22±1
				1	49	1	22.93	22±1
				25	0	2	22.35	22±1
				25	12	2	22.36	22±1
				25	24	2	22.31	22±1
				50	0	2	21.62	22±1
	18900	1880.0	QPSK	1	0	0	23.27	23±1
				1	24	0	23.29	23±1
				1	49	0	23.24	23±1
				25	0	1	22.46	23±1
				25	12	1	22.42	23±1
				25	24	1	22.45	23±1
				50	0	1	22.48	23±1
			16QAM	1	0	1	22.89	22±1
				1	24	1	22.82	22±1
				1	49	1	22.83	22±1
				25	0	2	22.45	22±1
				25	12	2	22.46	22±1
				25	24	2	22.43	22±1
				50	0	2	21.48	22±1
	19150	1905	QPSK	1	0	0	22.74	23±1
				1	24	0	22.75	23±1
1				49	0	22.71	23±1	
25				0	1	22.07	23±1	
25				12	1	22.09	23±1	
25				24	1	22.03	23±1	
50				0	1	22.08	23±1	
16QAM			1	0	1	21.86	22±1	
			1	24	1	21.83	22±1	
			1	49	1	21.89	22±1	
			25	0	2	21.56	22±1	
			25	12	2	21.59	22±1	
			25	24	2	21.51	22±1	
			50	0	2	21.26	22±1	

BW (MHz)	Ch	Freq. (MHz)	Mode	UL RB Allocation	UL RB Offset	MPR	Average power (dBm)	Tune up Power tolerant
5MHz	18625	1852.5	QPSK	1	0	0	23.41	23±1
				1	12	0	23.42	23±1
				1	24	0	23.46	23±1
				12	0	1	22.68	23±1
				12	6	1	22.69	23±1
				12	11	1	22.62	23±1
				25	0	1	22.57	23±1
			16QAM	1	0	1	22.58	22±1
				1	12	1	22.53	22±1
				1	24	1	22.56	22±1
				12	0	2	22.26	22±1
				12	6	2	22.24	22±1
				12	11	2	22.28	22±1
				25	0	2	21.64	22±1
	18900	1880.0	QPSK	1	0	0	23.51	23±1
				1	12	0	23.56	23±1
				1	24	0	23.51	23±1
				12	0	1	22.53	23±1
				12	6	1	22.54	23±1
				12	11	1	22.51	23±1
				25	0	1	22.60	23±1
			16QAM	1	0	1	22.89	22±1
				1	12	1	22.83	22±1
				1	24	1	22.86	22±1
				12	0	2	21.86	22±1
				12	6	2	21.89	22±1
				12	11	2	21.89	22±1
				25	0	2	21.61	22±1
	19175	1907.5	QPSK	1	0	0	23.05	23±1
				1	12	0	23.06	23±1
1				24	0	23.01	23±1	
12				0	1	22.36	23±1	
12				6	1	22.38	23±1	
12				11	1	22.34	23±1	
25				0	1	22.43	23±1	
16QAM			1	0	1	22.26	22±1	
			1	12	1	22.23	22±1	
			1	24	1	22.29	22±1	
			12	0	2	21.86	22±1	
			12	6	2	21.82	22±1	
			12	11	2	21.89	22±1	
			25	0	2	21.59	22±1	

BW (MHz)	Ch	Freq. (MHz)	Mode	UL RB Allocation	UL RB Offset	MPR	Average power (dBm)	Tune up Power tolerant
3MHz	18625	1852.5	QPSK	1	0	0	23.35	23±1
				1	7	0	23.36	23±1
				1	14	0	23.31	23±1
				8	0	1	22.63	23±1
				8	4	1	22.68	23±1
				8	7	1	22.61	23±1
				15	0	1	22.52	23±1
			16QAM	1	0	1	22.84	22±1
				1	7	1	22.83	22±1
				1	14	1	22.86	22±1
				8	0	2	21.46	22±1
				8	4	2	21.49	22±1
				8	7	2	21.43	22±1
				15	0	2	21.57	22±1
	18900	1880.0	QPSK	1	0	0	23.52	23±1
				1	7	0	23.56	23±1
				1	14	0	23.51	23±1
				8	0	1	22.54	23±1
				8	4	1	22.56	23±1
				8	7	1	22.53	23±1
				15	0	1	22.51	23±1
			16QAM	1	0	1	22.31	22±1
				1	7	1	22.36	22±1
				1	14	1	22.32	22±1
				8	0	2	21.43	22±1
				8	4	2	21.46	22±1
				8	7	2	21.42	22±1
				15	0	2	21.47	22±1
	19175	1907.5	QPSK	1	0	0	23.17	23±1
				1	7	0	23.13	23±1
1				14	0	23.16	23±1	
8				0	1	22.45	23±1	
8				4	1	22.46	23±1	
8				7	1	22.43	23±1	
15				0	1	22.53	23±1	
16QAM			1	0	1	22.42	22±1	
			1	7	1	22.45	22±1	
			1	14	1	22.46	22±1	
			8	0	2	21.44	22±1	
			8	4	2	21.45	22±1	
			8	7	2	21.42	22±1	
			15	0	2	21.71	22±1	

BW (MHz)	Ch	Freq. (MHz)	Mode	UL RB Allocation	UL RB Offset	MPR	Average power (dBm)	Tune up Power tolerant
1.4MHz	18607	1850.7	QPSK	1	0	0	23.28	23±1
				1	2	0	23.25	23±1
				1	5	0	23.26	23±1
				3	0	0	23.46	23±1
				3	1	0	23.45	23±1
				3	2	0	23.48	23±1
			6	0	1	22.65	23±1	
			16QAM	1	0	1	22.16	22±1
				1	2	1	22.13	22±1
				1	5	1	22.19	22±1
				3	0	1	21.69	22±1
				3	1	1	21.68	22±1
	3	2		1	21.65	22±1		
	6	0	2	21.47	22±1			
	18900	1880.0	QPSK	1	0	0	23.67	23±1
				1	2	0	23.69	23±1
				1	5	0	23.63	23±1
				3	0	0	23.61	23±1
				3	1	0	23.62	23±1
				3	2	0	23.64	23±1
			6	0	1	22.60	23±1	
			16QAM	1	0	1	22.37	22±1
				1	2	1	22.32	22±1
				1	5	1	22.35	22±1
				3	0	1	21.69	22±1
				3	1	1	21.68	22±1
	3	2		1	21.62	22±1		
	6	0	2	21.49	22±1			
	19193	1909.3	QPSK	1	0	0	22.95	23±1
				1	2	0	22.93	23±1
1				5	0	22.91	23±1	
3				0	0	23.04	23±1	
3				1	0	22.93	23±1	
3				2	0	22.96	23±1	
6			0	1	22.42	23±1		
16QAM			1	0	1	22.31	22±1	
			1	2	1	22.35	22±1	
			1	5	1	22.37	22±1	
			3	0	1	21.73	22±1	
			3	1	1	21.75	22±1	
	3	2	1	21.72	22±1			
6	0	2	21.49	22±1				

LTE Band 4:

BW (MHz)	Ch	Freq. (MHz)	Mode	UL RB Allocation	UL RB Offset	MPR	Average power (dBm)	Tune up Power tolerant
20MHz	20050	1720.0	QPSK	1	0	0	22.83	23±1
				1	49	0	22.86	23±1
				1	99	0	22.85	23±1
				50	0	1	22.79	23±1
				50	24	1	22.73	23±1
				50	49	1	22.76	23±1
			100	0	1	22.79	23±1	
			16QAM	1	0	1	23.09	23±1
				1	49	1	23.06	23±1
				1	99	1	23.04	23±1
				50	0	2	22.81	23±1
				50	24	2	22.85	23±1
	50	49		2	22.86	23±1		
	100	0	2	22.75	23±1			
	20175	1732.5	QPSK	1	0	0	22.83	23±1
				1	49	0	22.86	23±1
				1	99	0	22.85	23±1
				50	0	1	22.72	23±1
				50	24	1	22.76	23±1
				50	49	1	22.73	23±1
			100	0	1	22.74	23±1	
			16QAM	1	0	1	22.68	23±1
				1	49	1	22.69	23±1
				1	99	1	22.63	23±1
50				0	2	22.71	23±1	
50				24	2	22.72	23±1	
50	49	2		22.75	23±1			
100	0	2	22.66	23±1				
20300	1745.0	QPSK	1	0	0	22.74	23±1	
			1	49	0	22.76	23±1	
			1	99	0	22.71	23±1	
			50	0	1	22.82	23±1	
			50	24	1	22.86	23±1	
			50	49	1	22.84	23±1	
		100	0	1	22.81	23±1		
		16QAM	1	0	1	23.01	23±1	
			1	49	1	23.09	23±1	
			1	99	1	23.05	23±1	
			50	0	2	22.86	23±1	
			50	24	2	22.89	23±1	
50	49		2	22.83	23±1			
100	0	2	22.75	23±1				

BW (MHz)	Ch	Freq. (MHz)	Mode	UL RB Allocation	UL RB Offset	MPR	Average power (dBm)	Tune up Power tolerant
15MHz	20025	1717.5	QPSK	1	0	0	22.75	23 ± 1
				1	37	0	22.76	23 ± 1
				1	74	0	22.73	23 ± 1
				36	0	1	22.90	23 ± 1
				36	16	1	22.91	23 ± 1
				36	35	1	22.96	23 ± 1
				75	0	1	22.94	23 ± 1
			16QAM	1	0	1	23.21	23 ± 1
				1	37	1	23.25	23 ± 1
				1	74	1	23.26	23 ± 1
				36	0	2	23.01	23 ± 1
				36	16	2	23.06	23 ± 1
				36	35	2	23.02	23 ± 1
				75	0	2	22.94	23 ± 1
	20175	1732.5	QPSK	1	0	0	22.73	23 ± 1
				1	37	0	22.76	23 ± 1
				1	74	0	22.75	23 ± 1
				36	0	1	22.85	23 ± 1
				36	16	1	22.89	23 ± 1
				36	35	1	22.84	23 ± 1
				75	0	1	22.93	23 ± 1
			16QAM	1	0	1	23.08	23 ± 1
				1	37	1	23.04	23 ± 1
				1	74	1	23.09	23 ± 1
				36	0	2	22.95	23 ± 1
				36	16	2	22.93	23 ± 1
				36	35	2	22.94	23 ± 1
				75	0	2	22.90	23 ± 1
	20325	1747.5	QPSK	1	0	0	22.96	23 ± 1
				1	37	0	22.93	23 ± 1
1				74	0	22.98	23 ± 1	
36				0	1	22.88	23 ± 1	
36				16	1	22.86	23 ± 1	
36				35	1	22.85	23 ± 1	
75				0	1	22.87	23 ± 1	
16QAM			1	0	1	22.75	23 ± 1	
			1	37	1	22.73	23 ± 1	
			1	74	1	22.78	23 ± 1	
			36	0	2	22.78	23 ± 1	
			36	16	2	22.79	23 ± 1	
			36	35	2	22.79	23 ± 1	
			75	0	2	22.83	23 ± 1	

BW (MHz)	Ch	Freq. (MHz)	Mode	UL RB Allocation	UL RB Offset	MPR	Average power (dBm)	Tune up Power tolerant
10MHz	20000	1715.0	QPSK	1	0	0	22.72	23±1
				1	24	0	22.75	23±1
				1	49	0	22.73	23±1
				25	0	1	22.81	23±1
				25	12	1	22.85	23±1
				25	24	1	22.86	23±1
				50	0	1	22.90	23±1
			16QAM	1	0	1	23.22	23±1
				1	24	1	23.26	23±1
				1	49	1	23.24	23±1
				25	0	2	22.96	23±1
				25	12	2	22.93	23±1
				25	24	2	22.95	23±1
				50	0	2	22.88	23±1
	20175	1732.5	QPSK	1	0	0	22.34	23±1
				1	24	0	22.36	23±1
				1	49	0	22.38	23±1
				25	0	1	22.75	23±1
				25	12	1	22.72	23±1
				25	24	1	22.74	23±1
				50	0	1	22.74	23±1
			16QAM	1	0	1	22.07	23±1
				1	24	1	22.06	23±1
				1	49	1	22.09	23±1
				25	0	2	22.43	23±1
				25	12	2	22.46	23±1
				25	24	2	22.42	23±1
50				0	2	22.64	23±1	
20350	1750.0	QPSK	1	0	0	22.66	23±1	
			1	24	0	22.63	23±1	
			1	49	0	22.68	23±1	
			25	0	1	22.87	23±1	
			25	12	1	22.85	23±1	
			25	24	1	22.87	23±1	
			50	0	1	22.82	23±1	
		16QAM	1	0	1	22.96	23±1	
			1	24	1	22.93	23±1	
			1	49	1	22.97	23±1	
			25	0	2	22.78	23±1	
			25	12	2	22.76	23±1	
			25	24	2	22.73	23±1	
			50	0	2	22.76	23±1	

BW (MHz)	Ch	Freq. (MHz)	Mode	UL RB Allocation	UL RB Offset	MPR	Average power (dBm)	Tune up Power tolerant
5MHz	20000	1715.0	QPSK	1	0	0	22.88	23±1
				1	12	0	22.86	23±1
				1	24	0	22.83	23±1
				12	0	1	22.94	23±1
				12	6	1	22.93	23±1
				12	11	1	22.96	23±1
				25	0	1	22.89	23±1
			16QAM	1	0	1	22.82	23±1
				1	12	1	22.85	23±1
				1	24	1	22.87	23±1
				12	0	2	22.86	23±1
				12	6	2	22.85	23±1
				12	11	2	22.89	23±1
				25	0	2	22.91	23±1
	20175	1732.5	QPSK	1	0	0	22.73	23±1
				1	12	0	22.76	23±1
				1	24	0	22.75	23±1
				12	0	1	22.73	23±1
				12	6	1	22.78	23±1
				12	11	1	22.76	23±1
				25	0	1	22.72	23±1
			16QAM	1	0	1	22.97	23±1
				1	12	1	22.96	23±1
				1	24	1	22.95	23±1
				12	0	2	22.88	23±1
				12	6	2	22.85	23±1
				12	11	2	22.86	23±1
				25	0	2	22.61	23±1
	20350	1750.0	QPSK	1	0	0	22.81	23±1
				1	12	0	22.86	23±1
				1	24	0	22.84	23±1
				12	0	1	22.91	23±1
				12	6	1	22.95	23±1
				12	11	1	22.96	23±1
				25	0	1	22.84	23±1
			16QAM	1	0	1	22.91	23±1
1				12	1	22.92	23±1	
1				24	1	22.95	23±1	
12				0	2	22.86	23±1	
12				6	2	22.85	23±1	
12				11	2	22.83	23±1	
25				0	2	22.81	23±1	

BW (MHz)	Ch	Freq. (MHz)	Mode	UL RB Allocation	UL RB Offset	MPR	Average power (dBm)	Tune up Power tolerant
3MHz	19965	1711.5	QPSK	1	0	0	22.76	23±1
				1	7	0	22.72	23±1
				1	14	0	22.78	23±1
				8	0	1	22.92	23±1
				8	4	1	22.93	23±1
				8	7	1	22.96	23±1
				15	0	1	22.91	23±1
			16QAM	1	0	1	23.26	23±1
				1	7	1	23.25	23±1
				1	14	1	23.28	23±1
				8	0	2	22.87	23±1
				8	4	2	22.82	23±1
				8	7	2	22.85	23±1
				15	0	2	22.98	23±1
	20175	1732.5	QPSK	1	0	0	22.79	23±1
				1	7	0	22.76	23±1
				1	14	0	22.73	23±1
				8	0	1	22.81	23±1
				8	4	1	22.83	23±1
				8	7	1	22.86	23±1
				15	0	1	22.74	23±1
			16QAM	1	0	1	22.52	23±1
				1	7	1	22.56	23±1
				1	14	1	22.53	23±1
				8	0	2	22.72	23±1
				8	4	2	22.75	23±1
				8	7	2	22.76	23±1
				15	0	2	22.60	23±1
	20385	1753.5	QPSK	1	0	0	22.91	23±1
				1	7	0	22.96	23±1
1				14	0	22.94	23±1	
8				0	1	22.89	23±1	
8				4	1	22.86	23±1	
8				7	1	22.83	23±1	
15				0	1	22.88	23±1	
16QAM			1	0	1	22.82	23±1	
			1	7	1	22.89	23±1	
			1	14	1	22.84	23±1	
			8	0	2	22.68	23±1	
			8	4	2	22.69	23±1	
			8	7	2	22.63	23±1	
			15	0	2	22.84	23±1	

BW (MHz)	Ch	Freq. (MHz)	Mode	UL RB Allocation	UL RB Offset	MPR	Average power (dBm)	Tune up Power tolerant
1.4MHz	19957	1710.7	QPSK	1	0	0	22.89	22±1
				1	2	0	22.86	22±1
				1	5	0	22.83	22±1
				3	0	0	22.99	22±1
				3	1	0	22.96	22±1
				3	2	0	22.91	22±1
			6	0	1	22.93	22±1	
			16QAM	1	0	1	22.54	22±1
				1	2	1	22.56	22±1
				1	5	1	22.53	22±1
				3	0	1	22.58	22±1
				3	1	1	22.61	22±1
	3	2		1	22.64	22±1		
	20175	1732.5	QPSK	1	0	0	22.85	22±1
				1	2	0	22.86	22±1
				1	5	0	22.83	22±1
				3	0	0	22.76	22±1
				3	1	0	22.78	22±1
				3	2	0	22.72	22±1
			6	0	1	22.85	22±1	
			16QAM	1	0	1	22.58	22±1
				1	2	1	22.56	22±1
				1	5	1	22.53	22±1
				3	0	1	22.62	22±1
3				1	1	22.65	22±1	
3	2	1		22.63	22±1			
20393	1754.3	QPSK	1	0	0	22.93	22±1	
			1	2	0	22.96	22±1	
			1	5	0	22.91	22±1	
			3	0	0	22.97	22±1	
			3	1	0	22.92	22±1	
			3	2	0	22.95	22±1	
		6	0	1	22.90	22±1		
		16QAM	1	0	1	22.88	22±1	
			1	2	1	22.86	22±1	
			1	5	1	22.83	22±1	
			3	0	1	22.74	22±1	
			3	1	1	22.75	22±1	
3	2		1	22.71	22±1			
6	0	2	22.69	22±1				

LTE Band 5:

BW (MHz)	Ch	Freq. (MHz)	Mode	UL RB Allocation	UL RB Offset	MPR	Average power (dBm)	Tune up Power tolerant
10MHz	20450	829	QPSK	1	0	0	23.15	23±1
				1	24	0	23.18	23±1
				1	49	0	23.16	23±1
				25	0	1	22.35	23±1
				25	12	1	22.36	23±1
				25	24	1	22.39	23±1
				50	0	1	22.34	23±1
			16QAM	1	0	1	22.90	22±1
				1	24	1	22.93	22±1
				1	49	1	22.91	22±1
				25	0	2	22.51	22±1
				25	12	2	22.56	22±1
				25	24	2	22.53	22±1
				50	0	2	21.52	22±1
	20525	836.5	QPSK	1	0	0	23.49	23±1
				1	24	0	23.46	23±1
				1	49	0	23.42	23±1
				25	0	1	22.53	23±1
				25	12	1	22.56	23±1
				25	24	1	22.51	23±1
				50	0	1	22.51	23±1
			16QAM	1	0	1	22.98	22±1
				1	24	1	22.96	22±1
				1	49	1	22.93	22±1
				25	0	2	22.48	22±1
				25	12	2	22.46	22±1
				25	24	2	22.43	22±1
				50	0	2	21.65	22±1
	20600	844	QPSK	1	0	0	23.45	23±1
				1	24	0	23.42	23±1
1				49	0	23.48	23±1	
25				0	1	22.52	23±1	
25				12	1	22.56	23±1	
25				24	1	22.51	23±1	
50				0	1	22.52	23±1	
16QAM			1	0	1	22.99	22±1	
			1	24	1	22.96	22±1	
			1	49	1	22.95	22±1	
			25	0	2	22.52	22±1	
			25	12	2	22.56	22±1	
			25	24	2	22.52	22±1	
			50	0	2	21.65	22±1	

BW (MHz)	Ch	Freq. (MHz)	Mode	UL RB Allocation	UL RB Offset	MPR	Average power (dBm)	Tune up Power tolerant
5MHz	20425	826.5	QPSK	1	0	0	23.23	23±1
				1	12	0	23.26	23±1
				1	24	0	23.28	23±1
				12	0	1	22.29	23±1
				12	6	1	22.23	23±1
				12	11	1	22.28	23±1
				25	0	1	22.26	23±1
			16QAM	1	0	1	22.22	22±1
				1	12	1	22.23	22±1
				1	24	1	22.25	22±1
				12	0	2	22.05	22±1
				12	6	2	22.09	22±1
				12	11	2	22.06	22±1
				25	0	2	21.37	22±1
	20525	836.5	QPSK	1	0	0	23.39	23±1
				1	12	0	23.31	23±1
				1	24	0	23.34	23±1
				12	0	1	22.48	23±1
				12	6	1	22.46	23±1
				12	11	1	22.43	23±1
				25	0	1	22.45	23±1
			16QAM	1	0	1	22.87	22±1
				1	12	1	22.83	22±1
				1	24	1	22.82	22±1
				12	0	2	22.34	22±1
				12	6	2	22.36	22±1
				12	11	2	22.37	22±1
				25	0	2	21.52	22±1
	20625	846.5	QPSK	1	0	0	23.34	23±1
				1	12	0	23.36	23±1
1				24	0	23.31	23±1	
12				0	1	22.56	23±1	
12				6	1	22.59	23±1	
12				11	1	22.52	23±1	
25				0	1	22.52	23±1	
16QAM			1	0	1	22.45	22±1	
			1	12	1	22.49	22±1	
			1	24	1	22.43	22±1	
			12	0	2	21.86	22±1	
			12	6	2	21.89	22±1	
			12	11	2	21.84	22±1	
			25	0	2	21.66	22±1	

BW (MHz)	Ch	Freq. (MHz)	Mode	UL RB Allocation	UL RB Offset	MPR	Average power (dBm)	Tune up Power tolerant
3MHz	20415	825.5	QPSK	1	0	0	23.13	23±1
				1	7	0	23.16	23±1
				1	14	0	23.14	23±1
				8	0	1	22.22	23±1
				8	4	1	22.26	23±1
				8	7	1	22.23	23±1
				15	0	1	22.25	23±1
			16QAM	1	0	1	22.62	22±1
				1	7	1	22.65	22±1
				1	14	1	22.63	22±1
				8	0	2	21.21	22±1
				8	4	2	21.28	22±1
				8	7	2	21.25	22±1
				15	0	2	21.39	22±1
				20525	836.5	QPSK	1	0
	1	7	0				23.46	23±1
	1	14	0				23.41	23±1
	8	0	1				22.26	23±1
	8	4	1				22.29	23±1
	8	7	1				22.23	23±1
	15	0	1				22.40	23±1
	16QAM	1	0			1	22.27	22±1
		1	7			1	22.25	22±1
		1	14			1	22.23	22±1
		8	0			2	21.36	22±1
		8	4			2	21.38	22±1
		8	7			2	21.39	22±1
		15	0			2	21.47	22±1
		20635	847.5			QPSK	1	0
	1			7	0		23.45	23±1
1	14			0	23.46		23±1	
8	0			1	22.34		23±1	
8	4			1	22.36		23±1	
8	7			1	22.38		23±1	
15	0			1	22.54		23±1	
16QAM	1			0	1	22.40	22±1	
	1			7	1	22.46	22±1	
	1			14	1	22.42	22±1	
	8			0	2	21.31	22±1	
	8			4	2	21.35	22±1	
	8			7	2	21.36	22±1	
	15			0	2	21.65	22±1	

BW (MHz)	Ch	Freq. (MHz)	Mode	UL RB Allocation	UL RB Offset	MPR	Average power (dBm)	Tune up Power tolerant
1.4MHz	20407	824.7	QPSK	1	0	0	23.34	23±1
				1	2	0	23.36	23±1
				1	5	0	23.38	23±1
				3	0	0	23.39	23±1
				3	1	0	23.31	23±1
				3	2	0	23.38	23±1
				6	0	1	22.21	23±1
			16QAM	1	0	1	22.14	22±1
				1	2	1	22.19	22±1
				1	5	1	22.20	22±1
				3	0	1	21.86	22±1
				3	1	1	21.83	22±1
				3	2	1	21.85	22±1
				6	0	2	21.22	22±1
	20525	836.5	QPSK	1	0	0	23.37	23±1
				1	2	0	23.36	23±1
				1	5	0	23.31	23±1
				3	0	0	23.59	23±1
				3	1	0	23.56	23±1
				3	2	0	23.51	23±1
				6	0	1	22.23	23±1
			16QAM	1	0	1	22.45	22±1
				1	2	1	22.46	22±1
				1	5	1	22.43	22±1
				3	0	1	22.13	22±1
				3	1	1	22.19	22±1
				3	2	1	22.15	22±1
				6	0	2	21.24	22±1
	20643	848.3	QPSK	1	0	0	23.31	23±1
				1	2	0	23.35	23±1
1				5	0	23.36	23±1	
3				0	0	23.60	23±1	
3				1	0	23.63	23±1	
3				2	0	23.61	23±1	
6				0	1	22.35	23±1	
16QAM			1	0	1	22.05	22±1	
			1	2	1	22.09	22±1	
			1	5	1	22.05	22±1	
			3	0	1	21.75	22±1	
			3	1	1	21.79	22±1	
			3	2	1	21.76	22±1	
			6	0	2	21.39	22±1	

LTE Band 7:

BW (MHz)	Ch	Freq. (MHz)	Mode	UL RB Allocation	UL RB Offset	MPR	Average power (dBm)	Tune up Power tolerant
20MHz	20850	2510	QPSK	1	0	0	21.58	21.3±1
				1	49	0	21.56	21.3±1
				1	99	0	21.53	21.3±1
				50	0	1	21.11	21.3±1
				50	24	1	21.13	21.3±1
				50	49	1	21.16	21.3±1
				100	0	1	21.24	21.3±1
			16QAM	1	0	1	21.23	21.3±1
				1	49	1	21.25	21.3±1
				1	99	1	21.26	21.3±1
				50	0	2	20.75	21.3±1
				50	24	2	20.73	21.3±1
				50	49	2	20.75	21.3±1
				100	0	2	20.36	21.3±1
	21100	2535	QPSK	1	0	0	22.15	21.3±1
				1	49	0	22.13	21.3±1
				1	99	0	22.16	21.3±1
				50	0	1	20.88	21.3±1
				50	24	1	20.86	21.3±1
				50	49	1	20.83	21.3±1
				100	0	1	20.94	21.3±1
			16QAM	1	0	1	20.83	21.3±1
				1	49	1	20.86	21.3±1
				1	99	1	20.82	21.3±1
				50	0	2	20.62	21.3±1
				50	24	2	20.63	21.3±1
				50	49	2	20.65	21.3±1
				100	0	2	20.36	21.3±1
	21350	2560	QPSK	1	0	0	21.44	21.3±1
				1	49	0	21.45	21.3±1
1				99	0	21.43	21.3±1	
50				0	1	20.66	21.3±1	
50				24	1	20.68	21.3±1	
50				49	1	20.63	21.3±1	
100				0	1	20.63	21.3±1	
16QAM			1	0	1	20.75	21.3±1	
			1	49	1	20.72	21.3±1	
			1	99	1	20.73	21.3±1	
			50	0	2	20.56	21.3±1	
			50	24	2	20.59	21.3±1	
			50	49	2	20.58	21.3±1	
			100	0	2	20.34	21.3±1	

BW (MHz)	Ch	Freq. (MHz)	Mode	UL RB Allocation	UL RB Offset	MPR	Average power (dBm)	Tune up Power tolerant
15MHz	20825	1717.5	QPSK	1	0	0	21.81	21.3±1
				1	37	0	21.86	21.3±1
				1	74	0	21.83	21.3±1
				36	0	1	21.35	21.3±1
				36	16	1	21.36	21.3±1
				36	35	1	21.39	21.3±1
				75	0	1	21.35	21.3±1
			16QAM	1	0	1	21.45	21.3±1
				1	37	1	21.43	21.3±1
				1	74	1	21.43	21.3±1
				36	0	2	20.68	21.3±1
				36	16	2	20.69	21.3±1
				36	35	2	20.63	21.3±1
				75	0	2	20.36	21.3±1
	21100	1732.5	QPSK	1	0	0	22.14	21.3±1
				1	37	0	22.16	21.3±1
				1	74	0	22.15	21.3±1
				36	0	1	21.12	21.3±1
				36	16	1	21.15	21.3±1
				36	35	1	21.16	21.3±1
				75	0	1	21.14	21.3±1
			16QAM	1	0	1	20.75	21.3±1
				1	37	1	20.76	21.3±1
				1	74	1	20.73	21.3±1
				36	0	2	20.53	21.3±1
				36	16	2	20.56	21.3±1
				36	35	2	20.58	21.3±1
				75	0	2	20.35	21.3±1
	21375	1747.5	QPSK	1	0	0	21.63	21.3±1
				1	37	0	21.65	21.3±1
1				74	0	21.68	21.3±1	
36				0	1	20.74	21.3±1	
36				16	1	20.75	21.3±1	
36				35	1	20.76	21.3±1	
75				0	1	20.72	21.3±1	
16QAM			1	0	1	20.96	21.3±1	
			1	37	1	20.98	21.3±1	
			1	74	1	20.93	21.3±1	
			36	0	2	20.61	21.3±1	
			36	16	2	20.65	21.3±1	
			36	35	2	20.63	21.3±1	
			75	0	2	20.33	21.3±1	

BW (MHz)	Ch	Freq. (MHz)	Mode	UL RB Allocation	UL RB Offset	MPR	Average power (dBm)	Tune up Power tolerant
10MHz	20800	2502	QPSK	1	0	0	21.99	21.3±1
				1	24	0	21.98	21.3±1
				1	49	0	21.96	21.3±1
				25	0	1	21.28	21.3±1
				25	12	1	21.26	21.3±1
				25	24	1	21.29	21.3±1
				50	0	1	21.22	21.3±1
			16QAM	1	0	1	21.49	21.3±1
				1	24	1	21.46	21.3±1
				1	49	1	21.43	21.3±1
				25	0	2	20.95	21.3±1
				25	12	2	20.93	21.3±1
				25	24	2	20.98	21.3±1
				50	0	2	20.33	21.3±1
	21100	2535	QPSK	1	0	0	22.11	21.3±1
				1	24	0	22.15	21.3±1
				1	49	0	22.13	21.3±1
				25	0	1	20.94	21.3±1
				25	12	1	20.93	21.3±1
				25	24	1	20.95	21.3±1
				50	0	1	20.93	21.3±1
			16QAM	1	0	1	20.71	21.3±1
				1	24	1	20.73	21.3±1
				1	49	1	20.75	21.3±1
				25	0	2	20.65	21.3±1
				25	12	2	20.63	21.3±1
				25	24	2	20.62	21.3±1
				50	0	2	20.32	21.3±1
	21400	2565	QPSK	1	0	0	21.59	21.3±1
				1	24	0	21.56	21.3±1
1				49	0	21.58	21.3±1	
25				0	1	20.64	21.3±1	
25				12	1	20.63	21.3±1	
25				24	1	20.68	21.3±1	
50				0	1	20.65	21.3±1	
16QAM			1	0	1	20.93	21.3±1	
			1	24	1	20.96	21.3±1	
			1	49	1	20.95	21.3±1	
			25	0	2	20.64	21.3±1	
			25	12	2	20.61	21.3±1	
			25	24	2	20.63	21.3±1	
			50	0	2	20.34	21.3±1	

BW (MHz)	Ch	Freq. (MHz)	Mode	UL RB Allocation	UL RB Offset	MPR	Average power (dBm)	Tune up Power tolerant
5MHz	19975	1712.5	QPSK	1	0	0	22.23	22±1
				1	12	0	22.26	22±1
				1	24	0	22.24	22±1
				12	0	1	21.32	22±1
				12	6	1	21.36	22±1
				12	11	1	21.38	22±1
				25	0	1	21.27	22±1
			16QAM	1	0	1	21.09	21.3±1
				1	12	1	21.08	21.3±1
				1	24	1	21.03	21.3±1
				12	0	2	20.68	21.3±1
				12	6	2	20.69	21.3±1
				12	11	2	20.69	21.3±1
				25	0	2	20.36	21.3±1
	20175	1732.5	QPSK	1	0	0	22.45	22±1
				1	12	0	22.49	22±1
				1	24	0	22.48	22±1
				12	0	1	21.43	22±1
				12	6	1	21.46	22±1
				12	11	1	21.45	22±1
				25	0	1	21.42	22±1
			16QAM	1	0	1	21.64	21.3±1
				1	12	1	21.62	21.3±1
				1	24	1	21.63	21.3±1
				12	0	2	21.05	21.3±1
				12	6	2	21.08	21.3±1
				12	11	2	21.09	21.3±1
				25	0	2	20.32	21.3±1
	20375	1752.5	QPSK	1	0	0	22.04	22±1
				1	12	0	22.06	22±1
1				24	0	22.08	22±1	
12				0	1	21.16	22±1	
12				6	1	21.19	22±1	
12				11	1	21.18	22±1	
25				0	1	21.13	22±1	
16QAM			1	0	1	21.01	21.3±1	
			1	12	1	21.06	21.3±1	
			1	24	1	21.08	21.3±1	
			12	0	2	20.68	21.3±1	
			12	6	2	20.69	21.3±1	
			12	11	2	20.63	21.3±1	
			25	0	2	20.34	21.3±1	

LTE Band 17:

BW (MHz)	Ch	Freq. (MHz)	Mode	UL RB Allocation	UL RB Offset	MPR	Average power (dBm)	Tune up Power tolerant
10MHz	23780	709.0	QPSK	1	0	0	23.78	23±1
				1	24	0	23.72	23±1
				1	49	0	23.76	23±1
				25	0	1	22.92	23±1
				25	12	1	22.96	23±1
				25	24	1	22.91	23±1
				50	0	1	22.94	23±1
			16QAM	1	0	1	23.29	23±1
				1	24	1	23.26	23±1
				1	49	1	23.28	23±1
				25	0	2	22.86	23±1
				25	12	2	22.89	23±1
				25	24	2	22.85	23±1
				50	0	2	22.05	23±1
	23790	701.0	QPSK	1	0	0	23.56	23±1
				1	24	0	23.59	23±1
				1	49	0	23.51	23±1
				25	0	1	22.89	23±1
				25	12	1	22.86	23±1
				25	24	1	22.83	23±1
				50	0	1	22.92	23±1
			16QAM	1	0	1	22.52	22±1
				1	24	1	22.56	22±1
				1	49	1	22.58	22±1
				25	0	2	22.15	22±1
				25	12	2	22.16	22±1
				25	24	2	22.13	22±1
				50	0	2	21.97	22±1
	23800	711.0	QPSK	1	0	0	23.41	23±1
				1	24	0	23.46	23±1
1				49	0	23.42	23±1	
25				0	1	22.83	23±1	
25				12	1	22.86	23±1	
25				24	1	22.85	23±1	
50				0	1	22.89	23±1	
16QAM			1	0	1	22.46	22±1	
			1	24	1	22.43	22±1	
			1	49	1	22.45	22±1	
			25	0	2	22.06	22±1	
			25	12	2	22.08	22±1	
			25	24	2	22.04	22±1	
			50	0	2	21.97	22±1	

BW (MHz)	Ch	Freq. (MHz)	Mode	UL RB Allocation	UL RB Offset	MPR	Average power (dBm)	Tune up Power tolerant
5MHz	23755	706.5	QPSK	1	0	0	23.77	23±1
				1	12	0	23.72	23±1
				1	24	0	23.75	23±1
				12	0	1	22.88	23±1
				12	6	1	22.86	23±1
				12	11	1	22.83	23±1
			25	0	1	22.84	22±1	
			16QAM	1	0	1	22.73	22±1
			1	12	1	22.76	22±1	
			1	24	1	22.75	22±1	
			12	0	2	22.43	22±1	
			12	6	2	22.45	22±1	
	12	11	2	22.41	22±1			
	25	0	2	22.00	22±1			
	23790	710.0	QPSK	1	0	0	23.85	23±1
	1			12	0	23.86	23±1	
	1			24	0	23.82	23±1	
	12			0	1	22.91	23±1	
	12			6	1	22.93	23±1	
	12			11	1	22.95	23±1	
	25		0	1	22.88	23±1		
	16QAM		1	0	1	23.25	22.5±1	
	1		12	1	23.26	22.5±1		
	1		24	1	23.28	22.5±1		
	12		0	2	22.56	22.5±1		
	12		6	2	22.53	22.5±1		
	12	11	2	22.58	22.5±1			
	25	0	2	21.91	22.5±1			
	23825	713.5	QPSK	1	0	0	23.78	23±1
	1			12	0	23.72	23±1	
1	24			0	23.76	23±1		
12	0			1	22.88	23±1		
12	6			1	22.85	23±1		
12	11			1	22.83	23±1		
25	0		1	22.87	23±1			
16QAM	1		0	1	22.77	22±1		
1	12		1	22.73	22±1			
1	24		1	22.76	22±1			
12	0		2	22.34	22±1			
12	6		2	22.36	22±1			
12	11	2	22.38	22±1				
25	0	2	21.94	22±1				

ERP & EIRP

EIRP for LTE Band 2 (Part 24E)

Frequency (MHz)	BW (MHz)	Modulation	RB Size/Offset	Substituted level (dBm)	Antenna Polarization	Antenna Gain correction (dBi)	Cable Loss (dB)	Absolute Level (dBm)	Limit (dBm)
1850.7	1.4	QPSK	1/0	19.63	V	7.88	0.85	26.66	33.01
1880	1.4	QPSK	1/0	19.59	V	7.88	0.85	26.62	33.01
1909.3	1.4	QPSK	1/0	19.62	V	7.88	0.85	26.65	33.01
1850.7	1.4	QPSK	1/0	18.88	H	7.88	0.85	25.91	33.01
1880	1.4	QPSK	1/0	18.83	H	7.88	0.85	25.86	33.01
1909.3	1.4	QPSK	1/0	18.87	H	7.88	0.85	25.90	33.01
1850.7	1.4	16-QAM	1/0	18.51	V	7.88	0.85	25.54	33.01
1880	1.4	16-QAM	1/0	18.56	V	7.88	0.85	25.59	33.01
1909.3	1.4	16-QAM	1/0	18.57	V	7.88	0.85	25.60	33.01
1850.7	1.4	16-QAM	1/0	17.69	H	7.88	0.85	24.72	33.01
1880	1.4	16-QAM	1/0	17.72	H	7.88	0.85	24.75	33.01
1909.3	1.4	16-QAM	1/0	17.66	H	7.88	0.85	24.69	33.01
1851.5	3	QPSK	1/0	19.84	V	7.88	0.85	26.87	33.01
1880	3	QPSK	1/0	19.79	V	7.88	0.85	26.82	33.01
1908.5	3	QPSK	1/0	19.85	V	7.88	0.85	26.88	33.01
1851.5	3	QPSK	1/0	18.67	H	7.88	0.85	25.70	33.01
1880	3	QPSK	1/0	18.74	H	7.88	0.85	25.77	33.01
1908.5	3	QPSK	1/0	18.73	H	7.88	0.85	25.76	33.01
1851.5	3	16-QAM	1/0	18.69	V	7.88	0.85	25.72	33.01
1880	3	16-QAM	1/0	18.73	V	7.88	0.85	25.76	33.01
1908.5	3	16-QAM	1/0	18.68	V	7.88	0.85	25.71	33.01
1851.5	3	16-QAM	1/0	17.81	H	7.88	0.85	24.84	33.01
1880	3	16-QAM	1/0	17.85	H	7.88	0.85	24.88	33.01
1908.5	3	16-QAM	1/0	17.83	H	7.88	0.85	24.86	33.01
1852.5	5	QPSK	1/24	19.59	V	7.88	0.85	26.62	33.01
1880	5	QPSK	1/0	19.61	V	7.88	0.85	26.64	33.01
1907.5	5	QPSK	1/24	19.65	V	7.88	0.85	26.68	33.01
1852.5	5	QPSK	1/24	18.73	H	7.88	0.85	25.76	33.01
1880	5	QPSK	1/0	18.79	H	7.88	0.85	25.82	33.01
1907.5	5	QPSK	1/24	18.81	H	7.88	0.85	25.84	33.01
1852.5	5	16-QAM	1/24	18.44	V	7.88	0.85	25.47	33.01
1880	5	16-QAM	1/0	18.49	V	7.88	0.85	25.52	33.01

1907.5	5	16-QAM	1/24	18.52	V	7.88	0.85	25.55	33.01
1852.5	5	16-QAM	1/24	17.68	H	7.88	0.85	24.71	33.01
1880	5	16-QAM	1/0	17.73	H	7.88	0.85	24.76	33.01
1907.5	5	16-QAM	1/24	17.69	H	7.88	0.85	24.72	33.01
1855	10	QPSK	1/0	19.78	V	7.88	0.85	26.81	33.01
1880	10	QPSK	1/0	19.73	V	7.88	0.85	26.76	33.01
1905	10	QPSK	1/49	19.81	V	7.88	0.85	26.84	33.01
1855	10	QPSK	1/0	18.56	H	7.88	0.85	25.59	33.01
1880	10	QPSK	1/0	18.62	H	7.88	0.85	25.65	33.01
1905	10	QPSK	1/49	18.57	H	7.88	0.85	25.60	33.01
1855	10	16-QAM	1/0	18.61	V	7.88	0.85	25.64	33.01
1880	10	16-QAM	1/0	18.58	V	7.88	0.85	25.61	33.01
1905	10	16-QAM	1/49	18.63	V	7.88	0.85	25.66	33.01
1855	10	16-QAM	1/0	17.88	H	7.88	0.85	24.91	33.01
1880	10	16-QAM	1/0	17.95	H	7.88	0.85	24.98	33.01
1905	10	16-QAM	1/49	17.84	H	7.88	0.85	24.87	33.01
1857.5	15	QPSK	1/0	19.77	V	7.88	0.85	26.80	33.01
1880	15	QPSK	1/0	19.85	V	7.88	0.85	26.88	33.01
1902.5	15	QPSK	1/0	19.78	V	7.88	0.85	26.81	33.01
1857.5	15	QPSK	1/0	18.61	H	7.88	0.85	25.64	33.01
1880	15	QPSK	1/0	18.58	H	7.88	0.85	25.61	33.01
1902.5	15	QPSK	1/0	18.64	H	7.88	0.85	25.67	33.01
1857.5	15	16-QAM	1/0	18.69	V	7.88	0.85	25.72	33.01
1880	15	16-QAM	1/0	18.62	V	7.88	0.85	25.65	33.01
1902.5	15	16-QAM	1/0	18.65	V	7.88	0.85	25.68	33.01
1857.5	15	16-QAM	1/0	17.85	H	7.88	0.85	24.88	33.01
1880	15	16-QAM	1/0	17.89	H	7.88	0.85	24.92	33.01
1902.5	15	16-QAM	1/0	17.81	H	7.88	0.85	24.84	33.01
1860	20	QPSK	1/0	19.83	V	7.88	0.85	26.86	33.01
1880	20	QPSK	1/0	19.79	V	7.88	0.85	26.82	33.01
1900	20	QPSK	1/0	19.85	V	7.88	0.85	26.88	33.01
1860	20	QPSK	1/0	18.72	H	7.88	0.85	25.75	33.01
1880	20	QPSK	1/0	18.68	H	7.88	0.85	25.71	33.01
1900	20	QPSK	1/0	18.73	H	7.88	0.85	25.76	33.01
1860	20	16-QAM	1/0	18.71	V	7.88	0.85	25.74	33.01
1880	20	16-QAM	1/0	18.67	V	7.88	0.85	25.70	33.01
1900	20	16-QAM	1/0	18.75	V	7.88	0.85	25.78	33.01
1860	20	16-QAM	1/0	17.69	H	7.88	0.85	24.72	33.01

Test Report	15070962-FCC-R5
Page	37 of 133

1880	20	16-QAM	1/0	17.73	H	7.88	0.85	24.76	33.01
1900	20	16-QAM	1/0	17.64	H	7.88	0.85	24.67	33.01

EIRP for LTE Band 4 (Part 27)

Frequency (MHz)	BW (MHz)	Modulation	RB Size/Offset	Substituted level (dBm)	Antenna Polarization	Antenna Gain correction (dBi)	Cable Loss (dB)	Absolute Level (dBm)	Limit (dBm)
1710.7	1.4	QPSK	1/0	19.15	V	7.95	0.79	26.31	30
1732.5	1.4	QPSK	1/0	19.19	V	7.95	0.79	26.35	30
1754.3	1.4	QPSK	1/0	19.08	V	7.95	0.79	26.24	30
1710.7	1.4	QPSK	1/0	18.46	H	7.95	0.79	25.62	30
1732.5	1.4	QPSK	1/0	18.52	H	7.95	0.79	25.68	30
1754.3	1.4	QPSK	1/0	18.49	H	7.95	0.79	25.65	30
1710.7	1.4	16-QAM	1/5	18.08	V	7.95	0.79	25.24	30
1732.5	1.4	16-QAM	1/0	18.12	V	7.95	0.79	25.28	30
1754.3	1.4	16-QAM	1/0	18.07	V	7.95	0.79	25.23	30
1710.7	1.4	16-QAM	1/5	17.33	H	7.95	0.79	24.49	30
1732.5	1.4	16-QAM	1/0	17.29	H	7.95	0.79	24.45	30
1754.3	1.4	16-QAM	1/0	17.38	H	7.95	0.79	24.54	30
1711.5	3	QPSK	1/0	19.16	V	7.95	0.79	26.32	30
1732.5	3	QPSK	1/0	19.12	V	7.95	0.79	26.28	30
1753.5	3	QPSK	1/0	19.15	V	7.95	0.79	26.31	30
1711.5	3	QPSK	1/0	18.39	H	7.95	0.79	25.55	30
1732.5	3	QPSK	1/0	18.42	H	7.95	0.79	25.58	30
1753.5	3	QPSK	1/0	18.38	H	7.95	0.79	25.54	30
1711.5	3	16-QAM	1/0	18.08	V	7.95	0.79	25.24	30
1732.5	3	16-QAM	1/0	18.11	V	7.95	0.79	25.27	30
1753.5	3	16-QAM	1/0	18.09	V	7.95	0.79	25.25	30
1711.5	3	16-QAM	1/0	17.26	H	7.95	0.79	24.42	30
1732.5	3	16-QAM	1/0	17.31	H	7.95	0.79	24.47	30
1753.5	3	16-QAM	1/0	17.27	H	7.95	0.79	24.43	30
1712.5	5	QPSK	1/0	19.22	V	7.95	0.79	26.38	30
1732.5	5	QPSK	1/0	19.17	V	7.95	0.79	26.33	30
1752.5	5	QPSK	1/24	19.16	V	7.95	0.79	26.32	30
1712.5	5	QPSK	1/0	18.33	H	7.95	0.79	25.49	30
1732.5	5	QPSK	1/0	18.31	H	7.95	0.79	25.47	30
1752.5	5	QPSK	1/24	18.36	H	7.95	0.79	25.52	30
1712.5	5	16-QAM	1/0	18.19	V	7.95	0.79	25.35	30
1732.5	5	16-QAM	1/0	18.15	V	7.95	0.79	25.31	30
1752.5	5	16-QAM	1/24	18.18	V	7.95	0.79	25.34	30

1712.5	5	16-QAM	1/0	17.29	H	7.95	0.79	24.45	30
1732.5	5	16-QAM	1/0	17.35	H	7.95	0.79	24.51	30
1752.5	5	16-QAM	1/24	17.33	H	7.95	0.79	24.49	30
1715	10	QPSK	1/0	19.13	V	7.95	0.79	26.29	30
1732.5	10	QPSK	1/49	19.09	V	7.95	0.79	26.25	30
1750	10	QPSK	1/0	19.15	V	7.95	0.79	26.31	30
1715	10	QPSK	1/0	18.36	H	7.95	0.79	25.52	30
1732.5	10	QPSK	1/49	18.31	H	7.95	0.79	25.47	30
1750	10	QPSK	1/0	18.29	H	7.95	0.79	25.45	30
1715	10	16-QAM	1/0	18.09	V	7.95	0.79	25.25	30
1732.5	10	16-QAM	1/49	18.11	V	7.95	0.79	25.27	30
1750	10	16-QAM	1/0	18.08	V	7.95	0.79	25.24	30
1715	10	16-QAM	1/0	17.22	H	7.95	0.79	24.38	30
1732.5	10	16-QAM	1/49	17.29	H	7.95	0.79	24.45	30
1750	10	16-QAM	1/0	17.31	H	7.95	0.79	24.47	30
1717.5	15	QPSK	1/0	19.18	V	7.95	0.79	26.34	30
1732.5	15	QPSK	1/74	19.21	V	7.95	0.79	26.37	30
1747.5	15	QPSK	1/0	19.17	V	7.95	0.79	26.33	30
1717.5	15	QPSK	1/0	18.36	H	7.95	0.79	25.52	30
1732.5	15	QPSK	1/74	18.31	H	7.95	0.79	25.47	30
1747.5	15	QPSK	1/0	18.33	H	7.95	0.79	25.49	30
1717.5	15	16-QAM	1/0	18.06	V	7.95	0.79	25.22	30
1732.5	15	16-QAM	1/74	18.09	V	7.95	0.79	25.25	30
1747.5	15	16-QAM	1/0	18.05	V	7.95	0.79	25.21	30
1717.5	15	16-QAM	1/0	17.26	H	7.95	0.79	24.42	30
1732.5	15	16-QAM	1/74	17.29	H	7.95	0.79	24.45	30
1747.5	15	16-QAM	1/0	17.25	H	7.95	0.79	24.41	30
1720	20	QPSK	1/99	19.25	V	7.95	0.79	26.41	30
1732.5	20	QPSK	1/99	19.21	V	7.95	0.79	26.37	30
1745	20	QPSK	1/0	19.18	V	7.95	0.79	26.34	30
1720	20	QPSK	1/99	18.35	H	7.95	0.79	25.51	30
1732.5	20	QPSK	1/99	18.32	H	7.95	0.79	25.48	30
1745	20	QPSK	1/0	18.29	H	7.95	0.79	25.45	30
1720	20	16-QAM	1/99	18.16	V	7.95	0.79	25.32	30
1732.5	20	16-QAM	1/99	18.15	V	7.95	0.79	25.31	30
1745	20	16-QAM	1/0	18.11	V	7.95	0.79	25.27	30
1720	20	16-QAM	1/99	17.29	H	7.95	0.79	24.45	30
1732.5	20	16-QAM	1/99	17.32	H	7.95	0.79	24.48	30

Test Report	15070962-FCC-R5
Page	40 of 133

1745	20	16-QAM	1/0	17.25	H	7.95	0.79	24.41	30
------	----	--------	-----	-------	---	------	------	-------	----

EIRP for LTE Band 5 (Part 22)

Frequency (MHz)	BW (MHz)	Modulation	RB Size/Offset	Substituted level (dBm)	Antenna Polarization	Antenna Gain correction (dBi)	Cable Loss (dB)	Absolute Level (dBm)	Limit (dBm)
824.7	1.4	QPSK	1/5	18.52	V	6.8	0.44	24.88	34.77
836.5	1.4	QPSK	1/5	18.55	V	6.8	0.44	24.91	34.77
848.3	1.4	QPSK	1/5	18.56	V	6.9	0.44	25.02	34.77
824.7	1.4	QPSK	1/5	17.71	H	6.8	0.44	24.07	34.77
836.5	1.4	QPSK	1/5	17.75	H	6.8	0.44	24.11	34.77
848.3	1.4	QPSK	1/5	17.69	H	6.9	0.44	24.15	34.77
824.7	1.4	16-QAM	1/5	17.43	V	6.8	0.44	23.79	34.77
836.5	1.4	16-QAM	1/5	17.48	V	6.8	0.44	23.84	34.77
848.3	1.4	16-QAM	1/5	17.42	V	6.9	0.44	23.88	34.77
824.7	1.4	16-QAM	1/5	16.67	H	6.8	0.44	23.03	34.77
836.5	1.4	16-QAM	1/5	16.73	H	6.8	0.44	23.09	34.77
848.3	1.4	16-QAM	1/5	16.69	H	6.9	0.44	23.15	34.77
825.5	3	QPSK	1/14	18.52	V	6.8	0.44	24.88	34.77
836.5	3	QPSK	1/0	18.47	V	6.8	0.44	24.83	34.77
847.5	3	QPSK	1/14	18.51	V	6.9	0.44	24.97	34.77
825.5	3	QPSK	1/14	17.66	H	6.8	0.44	24.02	34.77
836.5	3	QPSK	1/0	17.62	H	6.8	0.44	23.98	34.77
847.5	3	QPSK	1/14	17.69	H	6.9	0.44	24.15	34.77
825.5	3	16-QAM	1/14	17.43	V	6.8	0.44	23.79	34.77
836.5	3	16-QAM	1/0	17.41	V	6.8	0.44	23.77	34.77
847.5	3	16-QAM	1/14	17.48	V	6.9	0.44	23.94	34.77
825.5	3	16-QAM	1/14	16.63	H	6.8	0.44	22.99	34.77
836.5	3	16-QAM	1/0	16.67	H	6.8	0.44	23.03	34.77
847.5	3	16-QAM	1/14	16.61	H	6.9	0.44	23.07	34.77
826.5	5	QPSK	1/24	18.53	V	6.8	0.44	24.89	34.77
836.5	5	QPSK	1/24	18.56	V	6.8	0.44	24.92	34.77
846.5	5	QPSK	1/24	18.51	V	6.8	0.44	24.87	34.77
826.5	5	QPSK	1/24	17.75	H	6.8	0.44	24.11	34.77
836.5	5	QPSK	1/24	17.68	H	6.8	0.44	24.04	34.77
846.5	5	QPSK	1/24	17.72	H	6.8	0.44	24.08	34.77
826.5	5	16-QAM	1/24	17.47	V	6.8	0.44	23.83	34.77
836.5	5	16-QAM	1/24	17.44	V	6.8	0.44	23.80	34.77
846.5	5	16-QAM	1/24	17.39	V	6.8	0.44	23.75	34.77

826.5	5	16-QAM	1/24	16.52	H	6.8	0.44	22.88	34.77
836.5	5	16-QAM	1/24	16.48	H	6.8	0.44	22.84	34.77
846.5	5	16-QAM	1/24	16.53	H	6.8	0.44	22.89	34.77
829	10	QPSK	1/49	18.51	V	6.8	0.44	24.87	34.77
836.5	10	QPSK	1/49	18.55	V	6.8	0.44	24.91	34.77
844	10	QPSK	1/49	18.58	V	6.8	0.44	24.94	34.77
829	10	QPSK	1/49	17.68	H	6.8	0.44	24.04	34.77
836.5	10	QPSK	1/49	17.65	H	6.8	0.44	24.01	34.77
844	10	QPSK	1/49	17.69	H	6.8	0.44	24.05	34.77
829	10	16-QAM	1/49	17.48	V	6.8	0.44	23.84	34.77
836.5	10	16-QAM	1/49	17.45	V	6.8	0.44	23.81	34.77
844	10	16-QAM	1/49	17.46	V	6.8	0.44	23.82	34.77
829	10	16-QAM	1/49	16.68	H	6.8	0.44	23.04	34.77
836.5	10	16-QAM	1/49	16.72	H	6.8	0.44	23.08	34.77
844	10	16-QAM	1/49	16.65	H	6.8	0.44	23.01	34.77

ERP for LTE Band 7 (Part 27)

Frequency (MHz)	BW (MHz)	Modulation	RB Size/Offset	Substituted level (dBm)	Antenna Polarization	Antenna Gain correction (dBi)	Cable Loss (dB)	Absolute Level (dBm)	Limit (dBm)
2502.5	5	QPSK	1/0	16.82	V	8.93	0.83	24.92	30
2535	5	QPSK	1/0	16.78	V	8.93	0.83	24.88	30
2567.5	5	QPSK	1/24	16.79	V	8.93	0.83	24.89	30
2502.5	5	QPSK	1/0	15.72	H	8.93	0.83	23.82	30
2535	5	QPSK	1/0	17.76	H	8.93	0.83	25.86	30
2567.5	5	QPSK	1/24	17.75	H	8.93	0.83	25.85	30
2502.5	5	16-QAM	1/0	15.69	V	8.93	0.83	23.79	30
2535	5	16-QAM	1/0	15.72	V	8.93	0.83	23.82	30
2567.5	5	16-QAM	1/24	15.68	V	8.93	0.83	23.78	30
2502.5	5	16-QAM	1/0	14.85	H	8.93	0.83	22.95	30
2535	5	16-QAM	1/0	14.81	H	8.93	0.83	22.91	30
2567.5	5	16-QAM	1/24	14.88	H	8.93	0.83	22.98	30
2505	10	QPSK	1/0	16.63	V	8.93	0.83	24.73	30
2535	10	QPSK	1/49	16.58	V	8.93	0.83	24.68	30
2565	10	QPSK	1/0	16.59	V	8.93	0.83	24.69	30
2505	10	QPSK	1/0	15.75	H	8.93	0.83	23.85	30
2535	10	QPSK	1/49	15.73	H	8.93	0.83	23.83	30
2565	10	QPSK	1/0	15.69	H	8.93	0.83	23.79	30
2505	10	16-QAM	1/0	15.58	V	8.93	0.83	23.68	30
2535	10	16-QAM	1/49	15.53	V	8.93	0.83	23.63	30
2565	10	16-QAM	1/0	15.55	V	8.93	0.83	23.65	30
2505	10	16-QAM	1/0	14.69	H	8.93	0.83	22.79	30
2535	10	16-QAM	1/49	14.63	H	8.93	0.83	22.73	30
2565	10	16-QAM	1/0	14.67	H	8.93	0.83	22.77	30
2507.5	15	QPSK	1/0	16.36	V	8.93	0.83	24.46	30
2535	15	QPSK	1/74	16.42	V	8.93	0.83	24.52	30
2562.5	15	QPSK	1/0	16.39	V	8.93	0.83	24.49	30
2507.5	15	QPSK	1/0	15.52	H	8.93	0.83	23.62	30
2535	15	QPSK	1/74	15.56	H	8.93	0.83	23.66	30
2562.5	15	QPSK	1/0	15.51	H	8.93	0.83	23.61	30
2507.5	15	16-QAM	1/0	15.28	V	8.93	0.83	23.38	30
2535	15	16-QAM	1/74	15.31	V	8.93	0.83	23.41	30
2562.5	15	16-QAM	1/0	15.33	V	8.93	0.83	23.43	30

2507.5	15	16-QAM	1/0	14.68	H	8.93	0.83	22.78	30
2535	15	16-QAM	1/74	14.63	H	8.93	0.83	22.73	30
2562.5	15	16-QAM	1/0	14.66	H	8.93	0.83	22.76	30
2510	20	QPSK	1/99	16.22	V	8.93	0.83	24.32	30
2535	20	QPSK	1/99	16.18	V	8.93	0.83	24.28	30
2560	20	QPSK	1/0	16.25	V	8.93	0.83	24.35	30
2510	20	QPSK	1/99	15.38	H	8.93	0.83	23.48	30
2535	20	QPSK	1/99	15.36	H	8.93	0.83	23.46	30
2560	20	QPSK	1/0	15.35	H	8.93	0.83	23.45	30
2510	20	16-QAM	1/99	15.12	V	8.93	0.83	23.22	30
2535	20	16-QAM	1/99	15.09	V	8.93	0.83	23.19	30
2560	20	16-QAM	1/0	15.13	V	8.93	0.83	23.23	30
2510	20	16-QAM	1/99	14.25	H	8.93	0.83	22.35	30
2535	20	16-QAM	1/99	14.31	H	8.93	0.83	22.41	30
2560	20	16-QAM	1/0	14.28	H	8.93	0.83	22.38	30

ERP for LTE Band 17 (Part 27)

Frequency (MHz)	BW (MHz)	Modulation	RB Size/Offset	Substituted level (dBm)	Antenna Polarization	Antenna Gain correction (dBi)	Cable Loss (dB)	Absolute Level (dBm)	Limit (dBm)
706.5	5	QPSK	1/0	19.05	V	6.8	0.42	25.43	34.77
710	5	QPSK	1/0	19.02	V	6.8	0.42	25.40	34.77
713.5	5	QPSK	1/0	18.96	V	6.8	0.42	25.34	34.77
706.5	5	QPSK	1/0	18.17	H	6.8	0.42	24.55	34.77
710	5	QPSK	1/0	18.12	H	6.8	0.42	24.50	34.77
713.5	5	QPSK	1/0	18.16	H	6.8	0.42	24.54	34.77
706.5	5	16-QAM	1/0	17.95	V	6.8	0.42	24.33	34.77
710	5	16-QAM	1/0	17.98	V	6.8	0.42	24.36	34.77
713.5	5	16-QAM	1/0	17.92	V	6.8	0.42	24.30	34.77
706.5	5	16-QAM	1/0	17.13	H	6.8	0.42	23.51	34.77
710	5	16-QAM	1/0	17.08	H	6.8	0.42	23.46	34.77
713.5	5	16-QAM	1/0	17.11	H	6.8	0.42	23.49	34.77
709	10	QPSK	1/0	18.86	V	6.8	0.42	25.24	34.77
710	10	QPSK	1/0	18.95	V	6.8	0.42	25.33	34.77
711	10	QPSK	1/0	18.89	V	6.8	0.42	25.27	34.77
709	10	QPSK	1/0	18.12	H	6.8	0.42	24.50	34.77
710	10	QPSK	1/0	18.07	H	6.8	0.42	24.45	34.77
711	10	QPSK	1/0	18.13	H	6.8	0.42	24.51	34.77
709	10	16-QAM	1/0	17.75	V	6.8	0.42	24.13	34.77
710	10	16-QAM	1/0	17.79	V	6.8	0.42	24.17	34.77
711	10	16-QAM	1/0	17.82	V	6.8	0.42	24.20	34.77
709	10	16-QAM	1/0	16.93	H	6.8	0.42	23.31	34.77
710	10	16-QAM	1/0	16.89	H	6.8	0.42	23.27	34.77
711	10	16-QAM	1/0	16.92	H	6.8	0.42	23.30	34.77

6.3 Peak-Average Ratio

Temperature	22°C
Relative Humidity	57%
Atmospheric Pressure	1005mbar
Test date :	November 05, 2015
Tested By :	Winnie Zhang

Requirement(s):

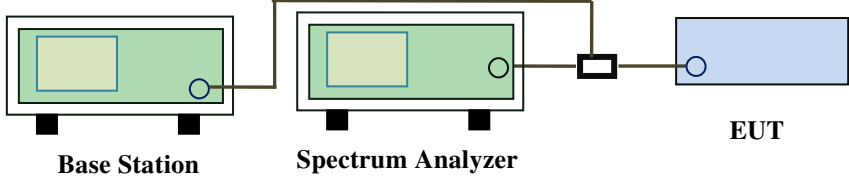
Spec	Item	Requirement	Applicable
§24.232(d) § 27.50(d)	a)	The peak-to-average ratio (PAR) of the transmission may not exceed 13 dB.	<input checked="" type="checkbox"/>
Test Setup	 <p style="text-align: center;">Base Station Spectrum Analyzer EUT</p>		
Test Procedure	<p>According with KDB 971168</p> <ol style="list-style-type: none"> 1. The signal analyzer' s CCDF measurement profile is enabled 2. Frequency = carrier center frequency 3. Measurement BW > Emission bandwidth of signal 4. The signal analyzer was set to collect one million samples to generate the CCDF curve 5. The measurement interval was set depending on the type of signal analyzed. For continuous signals (>98% duty cycle), the measurement interval was set to 1ms. For burst transmissions, the spectrum analyzer is set to use an internal “ RF Burst” trigger that is synced with an incoming pulse and the measurement interval is set to less than the duration of the “ on time” of one burst to ensure that energy is only captured during a time in which the transmitter is operating at maximum power 		
Remark			
Result	<input checked="" type="checkbox"/> Pass <input type="checkbox"/> Fail		

Test Data Yes N/A
 Test Plot Yes (See below) N/A

LTE Band 2 (part 24E)

BW(MHz)	Frequency (MHz)	Mode	Modulation	Conducted Power (dBm)		Peak-Average Ratio (PAR)
				Peak	Average	
1.4	1880	RB 1/0	QPSK	25.63	23.67	1.96
			16QAM	25.68	22.37	3.31
3	1880	RB 1/0	QPSK	25.69	23.52	2.17
			16QAM	25.65	22.31	3.34
5	1880	RB 1/0	QPSK	25.67	23.51	2.16
			16QAM	25.61	22.89	2.72
10	1880	RB 1/0	QPSK	25.83	23.27	2.56
			16QAM	25.46	22.89	2.57
15	1880	RB 1/0	QPSK	25.43	23.58	1.85
			16QAM	25.42	22.3	3.12
20	1880	RB 1/0	QPSK	25.56	23.56	2.00
			16QAM	25.53	22.39	3.14

LTE Band 4 (part 27)

BW(MHz)	Frequency (MHz)	Mode	Modulation	Conducted Power (dBm)		Peak-Average Ratio (PAR)
				Peak	Average	
1.4	1732.5	RB 1/0	QPSK	25.46	22.85	2.61
			16QAM	25.48	22.58	2.90
3	1732.5	RB 1/0	QPSK	25.35	22.79	2.56
			16QAM	25.62	22.52	3.10
5	1732.5	RB 1/0	QPSK	25.63	22.73	2.90
			16QAM	25.61	22.97	2.64
10	1732.5	RB 1/0	QPSK	25.34	22.34	3.00
			16QAM	25.11	22.07	3.04
15	1732.5	RB 1/0	QPSK	25.13	22.73	2.40
			16QAM	25.32	23.08	2.24
20	1732.5	RB 1/0	QPSK	25.16	22.83	2.33
			16QAM	25.26	22.68	2.58

LTE Band 5 (part 27)

BW(MHz)	Frequency (MHz)	Mode	Modulation	Conducted Power (dBm)		Peak-Average Ratio (PAR)
				Peak	Average	
1.4	836.5	RB 1/0	QPSK	25.26	23.37	1.89
			16QAM	25.23	22.45	2.78
3	836.5	RB 1/0	QPSK	25.31	23.4	1.91
			16QAM	25.24	22.27	2.97
5	836.5	RB 1/0	QPSK	25.13	23.39	1.74
			16QAM	25.19	22.87	2.32
10	836.5	RB 1/0	QPSK	25.23	23.49	1.74
			16QAM	25.37	22.98	2.39

LTE Band 7 (part 27)

BW(MHz)	Frequency (MHz)	Mode	Modulation	Conducted Power (dBm)		Peak-Average Ratio (PAR)
				Peak	Average	
5	2535	RB 1/0	QPSK	25.34	22.45	2.89
			16QAM	25.46	21.64	3.82
10	2535	RB 1/0	QPSK	25.48	22.11	3.37
			16QAM	25.42	20.71	4.71
15	2535	RB 1/0	QPSK	25.37	22.14	3.23
			16QAM	25.42	20.75	4.67
20	2535	RB 1/0	QPSK	25.39	22.15	3.24
			16QAM	25.33	20.83	4.50

LTE Band 17 (part 27)

BW(MHz)	Frequency (MHz)	Mode	Modulation	Conducted Power (dBm)		Peak-Average Ratio (PAR)
				Peak	Average	
5	710	RB 1/0	QPSK	25.35	23.85	1.50
			16QAM	25.32	23.25	2.07
10	710	RB 1/0	QPSK	25.36	23.56	1.80
			16QAM	25.42	22.52	2.90

Test Report	15070962-FCC-R5
Page	49 of 133

6.4 Modulation Characteristic

According to FCC § 2.1047(d), Part 22H&24E& Part 27 there is no specific requirement for digital modulation, therefore modulation characteristic is not presented.

6.5 Occupied Bandwidth

Temperature	22°C
Relative Humidity	57%
Atmospheric Pressure	1005mbar
Test date :	November 05, 2015
Tested By :	Winnie Zhang

Requirement(s):

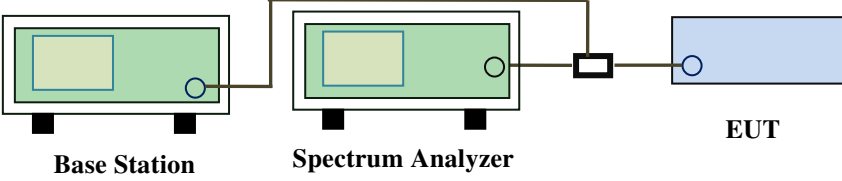
Spec	Item	Requirement	Applicable
§2.1049, §22.917, §22.905 §24.238 §27.53(a)	a)	99% Occupied Bandwidth(kHz)	<input checked="" type="checkbox"/>
	b)	26 dB Bandwidth(kHz)	<input checked="" type="checkbox"/>
Test Setup	 <p style="text-align: center;">Base Station Spectrum Analyzer EUT</p>		
Test Procedure	<ul style="list-style-type: none"> - The EUT was connected to Spectrum Analyzer and Base Station via power divider. - The 99% and 26 dB occupied bandwidth (BW) of the middle channel for the highest RF powers. 		
Remark			
Result	<input checked="" type="checkbox"/> Pass <input type="checkbox"/> Fail		

Test Data Yes N/A

Test Plot Yes (See below) N/A

LTE Band 2 (Part 24E)

BW(MHz)	Channel	Frequency (MHz)	Modulation	99% Occupied Bandwidth (MHz)	26 dB Bandwidth (MHz)
1.4	18607	1850.7	16QAM	1.1060	1.281
			QPSK	1.1025	1.285
1.4	18900	1880	16QAM	1.0954	1.269
			QPSK	1.0902	1.261
1.4	19193	1909.3	16QAM	1.1068	1.326
			QPSK	1.1072	1.309
3	18615	1851.5	16QAM	2.7470	3.095
			QPSK	2.7583	3.100
3	18900	1880	16QAM	2.7420	3.094
			QPSK	2.7456	3.088
3	19185	1908.5	16QAM	2.7466	3.057
			QPSK	2.7377	3.054
5	18625	1852.5	16QAM	4.5258	5.016
			QPSK	4.5236	5.099
5	18900	1880	16QAM	4.5147	5.097
			QPSK	4.5245	5.022
5	19175	1907.5	16QAM	4.5321	5.052
			QPSK	4.5083	5.053
10	18650	1855	16QAM	9.1151	11.064
			QPSK	9.0986	10.080
10	18900	1880	16QAM	9.0724	10.088
			QPSK	9.0641	10.101
10	19150	1905	16QAM	9.0876	10.204
			QPSK	9.0903	10.072
15	18675	1857.5	16QAM	13.4928	15.735
			QPSK	13.5566	15.155
15	18900	1880	16QAM	13.4386	14.778
			QPSK	13.5021	14.926
15	19125	1902.5	16QAM	13.5860	19.960
			QPSK	13.5633	18.519

20	18700	1860	16QAM	17.9148	19.257
			QPSK	17.9061	19.353
20	18900	1880	16QAM	17.8661	19.334
			QPSK	17.9007	19.222
20	19100	1900	16QAM	17.9914	23.683
			QPSK	18.0427	21.350

LTE Band 4 (Part 27)

BW(MHz)	Channel	Frequency (MHz)	Modulation	99% Occupied Bandwidth (MHz)	26 dB Bandwidth (MHz)
1.4	19957	1710.7	16QAM	1.0971	1.274
			QPSK	1.1003	1.279
1.4	20175	1732.5	16QAM	1.1282	1.988
			QPSK	1.1196	1.937
1.4	20393	1754.3	16QAM	1.1113	1.272
			QPSK	1.1009	1.283
3	19965	1711.5	16QAM	2.7401	3.063
			QPSK	2.7375	3.102
3	20175	1732.5	16QAM	2.7975	5.889
			QPSK	2.7915	4.252
3	20385	1753.5	16QAM	2.7359	3.059
			QPSK	2.7328	3.061
5	19975	1712.5	16QAM	4.5450	5.100
			QPSK	4.5259	5.036
5	20175	1732.5	16QAM	4.5785	7.676
			QPSK	4.5661	7.835
5	20375	1752.5	16QAM	4.5226	4.941
			QPSK	4.5138	5.038
10	20000	1715	16QAM	9.0480	10.132
			QPSK	9.0880	10.140
10	20175	1732.5	16QAM	9.1242	11.305
			QPSK	9.0890	11.260
10	20350	1750	16QAM	9.0633	10.005
			QPSK	9.0676	10.117

15	20025	1717.5	16QAM	13.5001	14.859
			QPSK	13.5189	14.557
15	20175	1732.5	16QAM	13.5101	16.175
			QPSK	13.5436	16.837
15	20325	1747.5	16QAM	13.5069	14.748
			QPSK	13.4950	14.855
20	20050	1720	16QAM	17.8851	19.280
			QPSK	17.8809	19.292
20	20175	1732.5	16QAM	17.8854	19.382
			QPSK	17.9128	20.466
20	20300	1745	16QAM	17.9366	19.576
			QPSK	17.9187	19.671

LTE Band 5 (Part 22H)

BW(MHz)	Channel	Frequency (MHz)	Modulation	99% Occupied Bandwidth (MHz)	26 dB Bandwidth (MHz)
1.4	20407	824.7	16QAM	1.0968	1.271
			QPSK	1.0932	1.256
1.4	20525	936.5	16QAM	1.1034	1.283
			QPSK	1.0980	1.276
1.4	20643	949.3	16QAM	1.0992	1.289
			QPSK	1.1000	1.289
3	20415	825.5	16QAM	2.7393	3.062
			QPSK	2.7350	3.055
3	20525	936.5	16QAM	2.7516	3.099
			QPSK	2.7424	3.088
3	20635	847.5	16QAM	2.7681	3.095
			QPSK	2.7443	3.090
5	20425	826.5	16QAM	4.5257	5.044
			QPSK	4.4964	5.032
5	20525	936.5	16QAM	4.5479	5.069
			QPSK	4.5419	5.081
5	20625	846.5	16QAM	4.5620	5.062
			QPSK	4.5339	5.007

10	20450	829	16QAM	9.0681	10.168
			QPSK	9.1057	10.185
10	20525	936.5	16QAM	9.0793	10.119
			QPSK	9.0901	10.072
10	20800	844	16QAM	9.0894	10.105
			QPSK	9.0895	10.028

LTE Band 7 (Part 27) result

BW(MHz)	Channel	Frequency (MHz)	Modulation	99% Occupied Bandwidth (MHz)	26 dB Bandwidth (MHz)
5	20775	2502.5	16QAM	4.5467	5.099
			QPSK	4.5242	4.988
5	21100	2535	16QAM	4.5235	5.152
			QPSK	4.5300	5.018
5	21425	2567.5	16QAM	4.5125	5.051
			QPSK	4.5069	4.978
10	20800	2505	16QAM	9.1254	10.492
			QPSK	9.1176	11.031
10	21100	2535	16QAM	9.1007	10.560
			QPSK	9.0869	10.374
10	21400	2562.5	16QAM	9.0641	10.086
			QPSK	9.0854	10.089
15	20825	2507.5	16QAM	13.5492	15.259
			QPSK	13.5810	15.054
15	21100	2535	16QAM	13.4983	17.942
			QPSK	13.4956	16.836
15	21400	2562.5	16QAM	13.5094	14.823
			QPSK	13.5057	14.789
20	20850	2510	16QAM	17.9891	19.485
			QPSK	17.9782	19.432
20	21100	2535	16QAM	17.8546	22.705
			QPSK	17.9026	19.327
20	21350	2560	16QAM	17.9595	19.433
			QPSK	17.9592	19.274

LTE Band 17 (Part 27)

BW(MHz)	Channel	Frequency (MHz)	Modulation	99% Occupied Bandwidth (MHz)	26 dB Bandwidth (MHz)
5	23755	706.5	16QAM	4.5086	5.019
			QPSK	4.5121	4.979
5	23790	710	16QAM	4.5242	5.030
			QPSK	4.5315	5.042
5	23825	713.5	16QAM	4.5153	5.011
			QPSK	4.5354	5.063
10	23780	709	16QAM	9.0848	10.140
			QPSK	9.1029	10.175
10	23790	710	16QAM	9.0902	10.289
			QPSK	9.1034	10.052
10	23800	711	16QAM	9.0785	10.103
			QPSK	9.0660	10.083

Test Plots

LTE Band 2 (Part 24E)

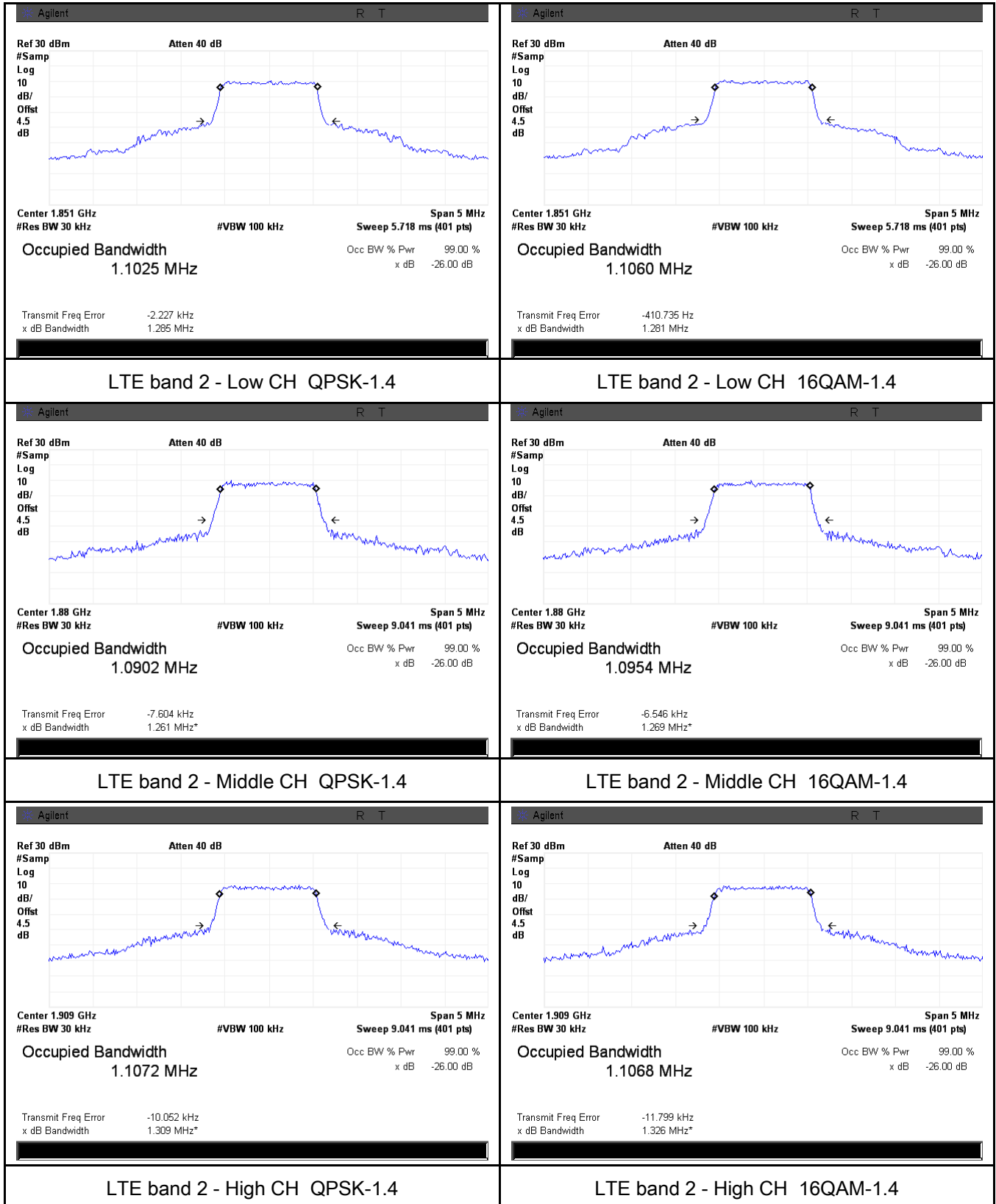

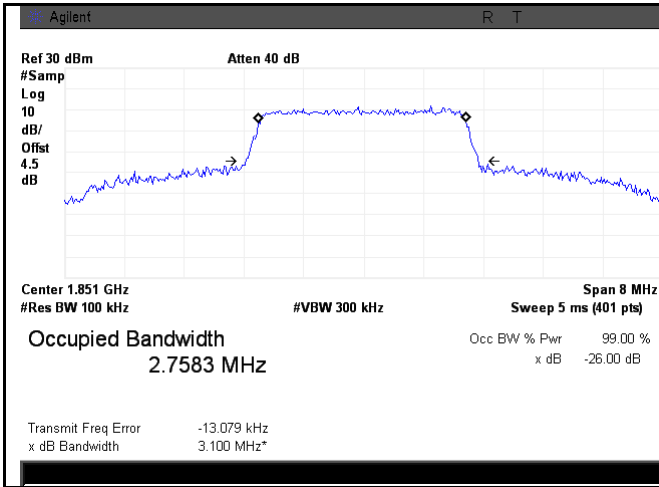

LTE band 2 - Low CH QPSK-3

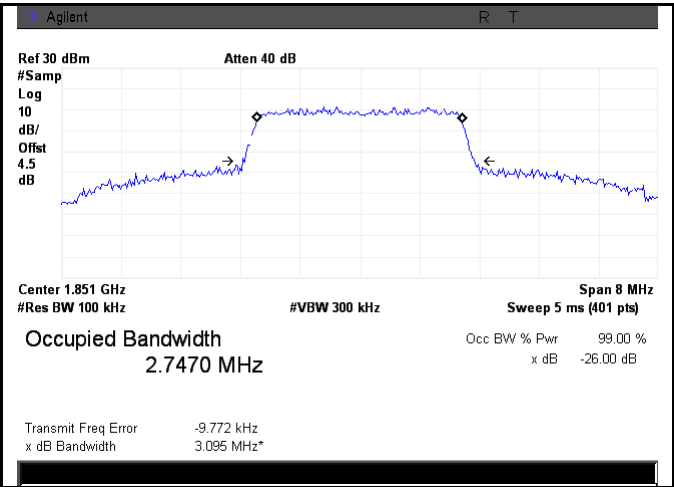

LTE band 2 - Low CH 16QAM-3

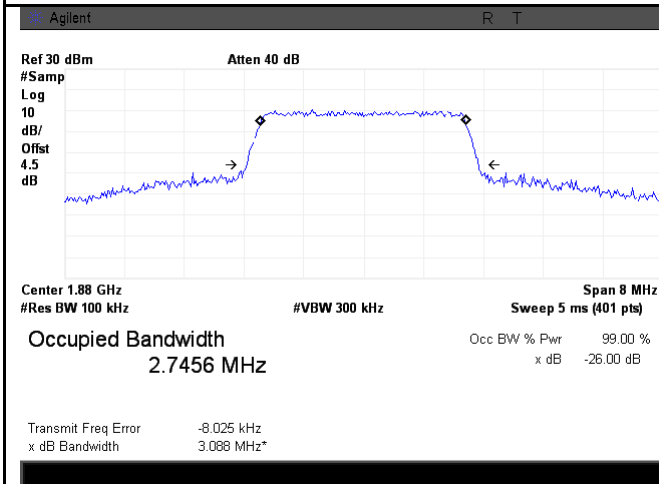

LTE band 2 - Middle CH QPSK-3

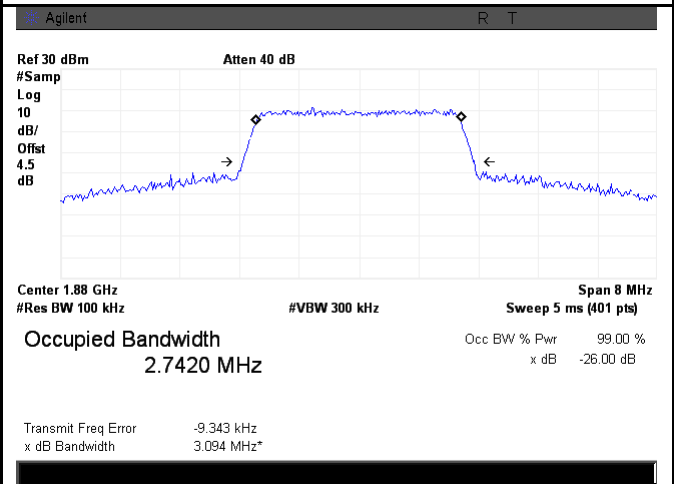

LTE band 2 - Middle CH 16QAM-3

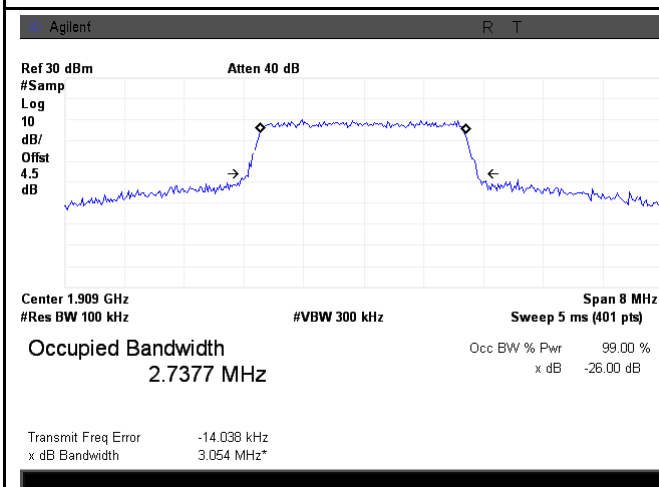

LTE band 2 - High CH QPSK-3

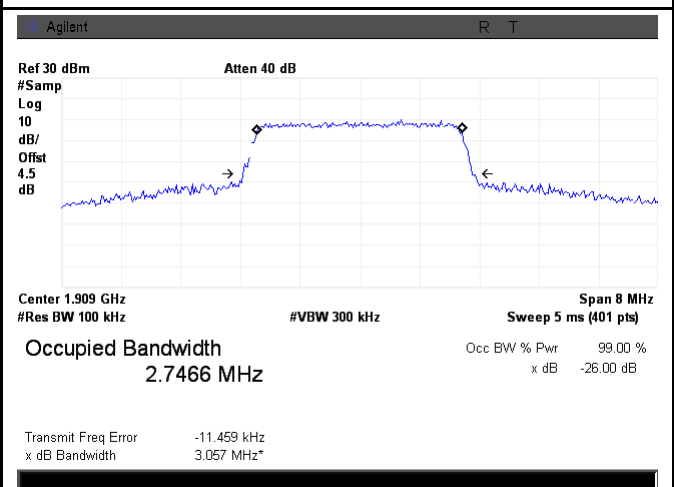

LTE band 2 - High CH 16QAM-3

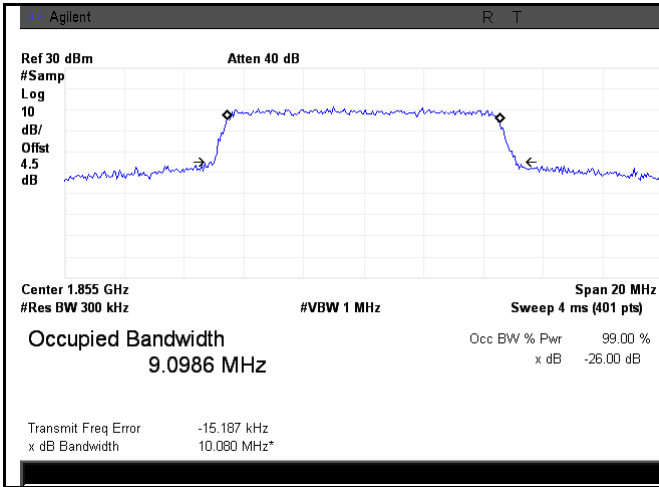

LTE band 2 - Low CH QPSK-10

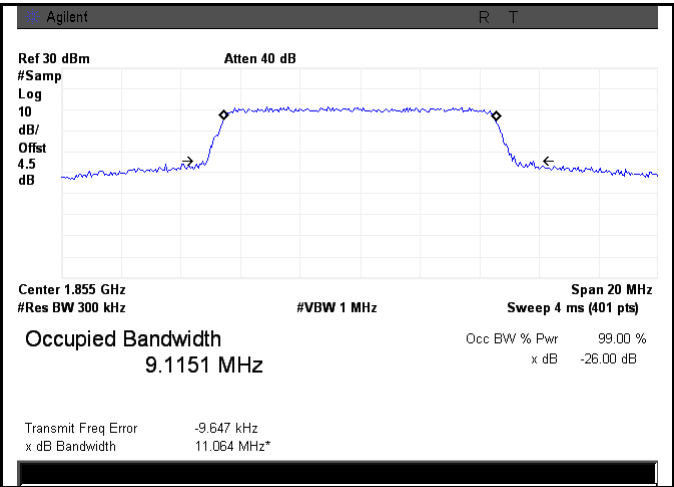

LTE band 2 - Low CH 16QAM-10

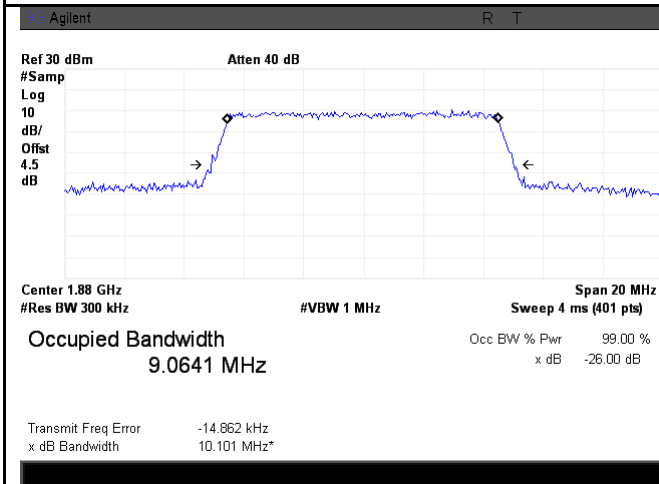

LTE band 2 - Middle CH QPSK-10

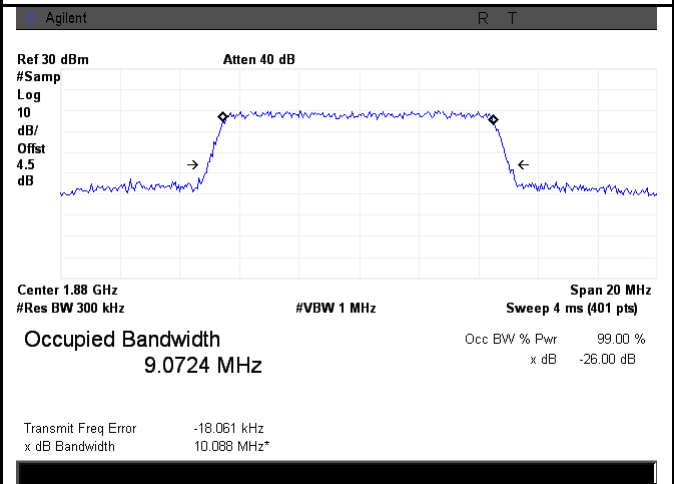

LTE band 2 - Middle CH 16QAM-10

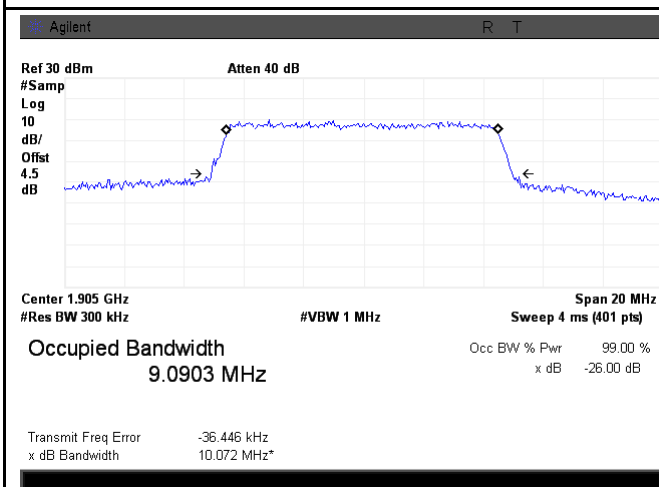

LTE band 2 - High CH QPSK-10

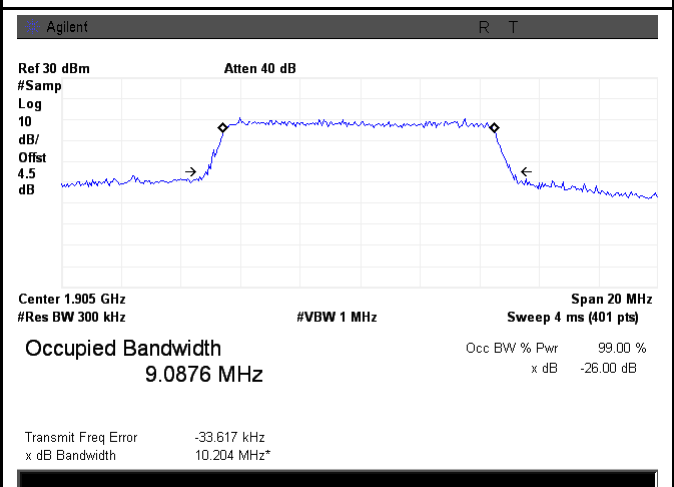

LTE band 2 - High CH 16QAM-10

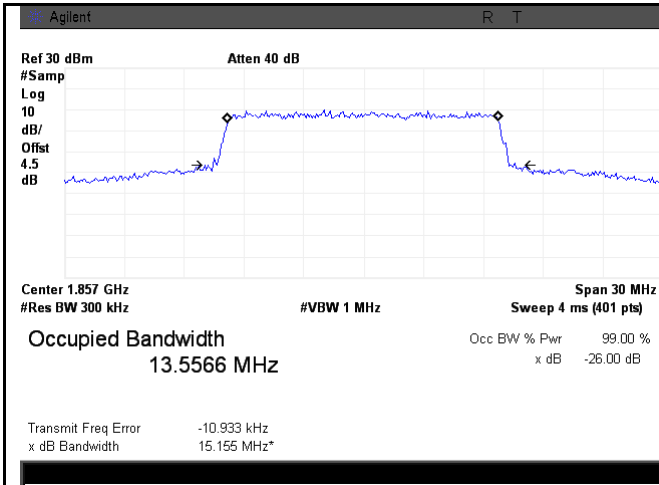

LTE band 2 - Low CH QPSK-15

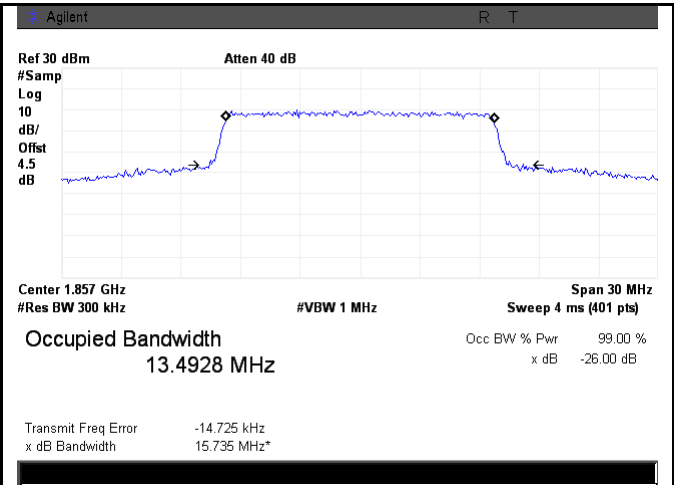

LTE band 2 - Low CH 16QAM-15

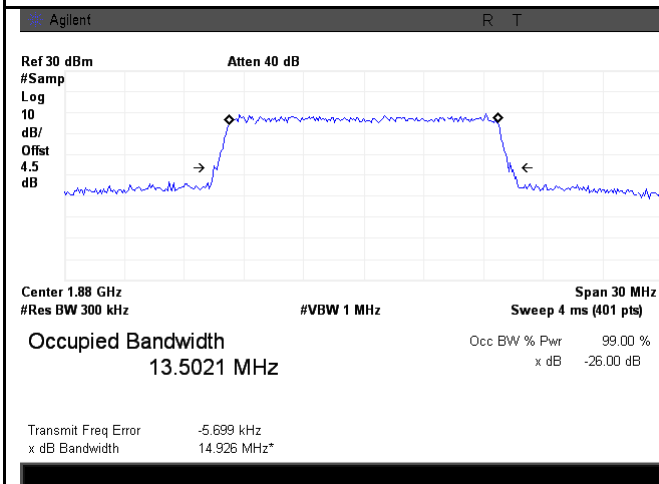

LTE band 2 - Middle CH QPSK-15

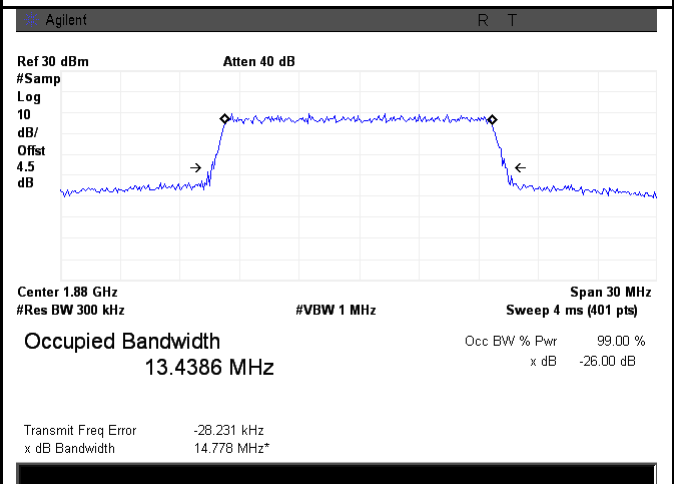

LTE band 2 - Middle CH 16QAM-15

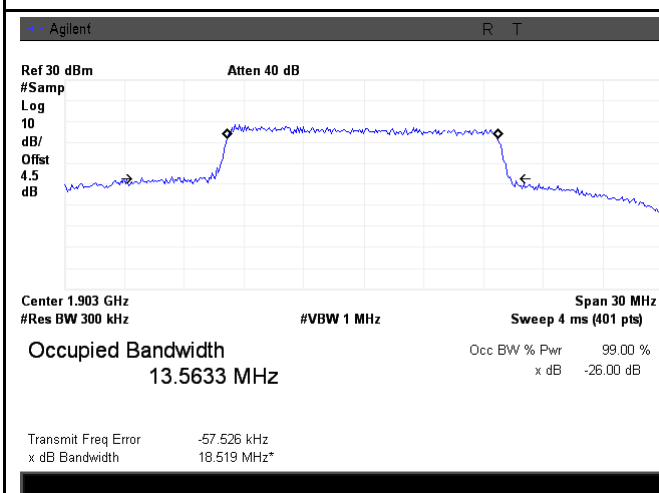

LTE band 2 - High CH QPSK-15

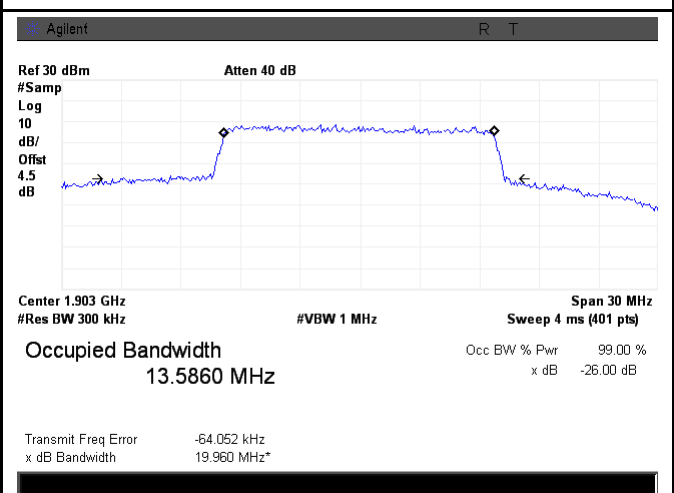

LTE band 2 - High CH 16QAM-15

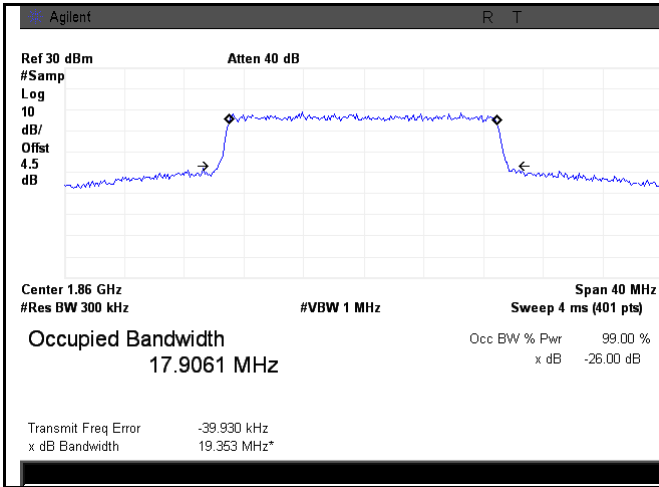

LTE band 2 - Low CH QPSK-20

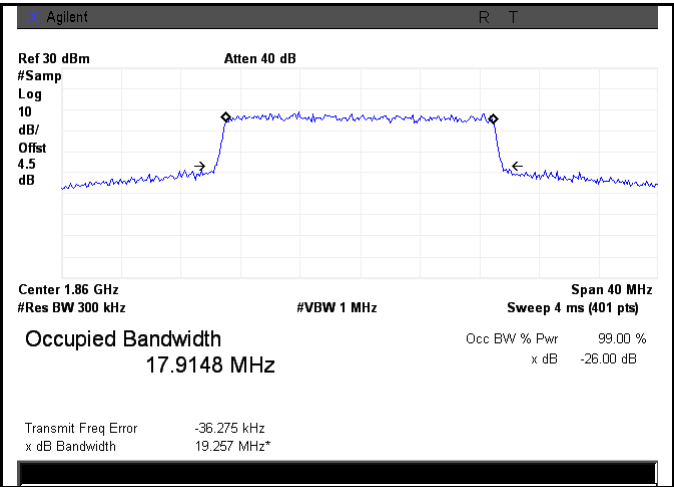

LTE band 2 - Low CH 16QAM-20

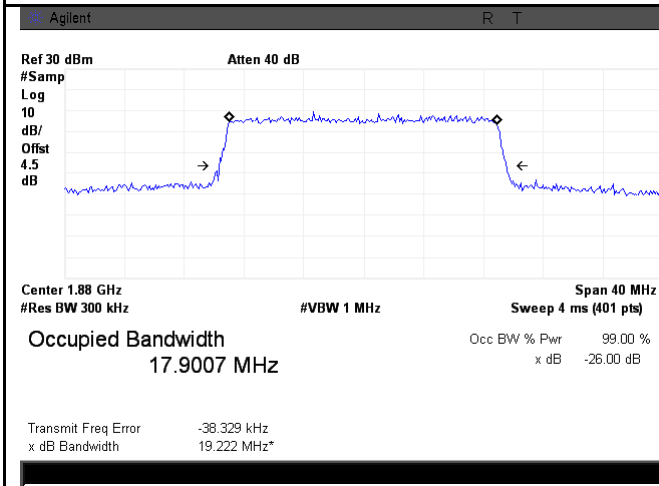

LTE band 2 - Middle CH QPSK-20

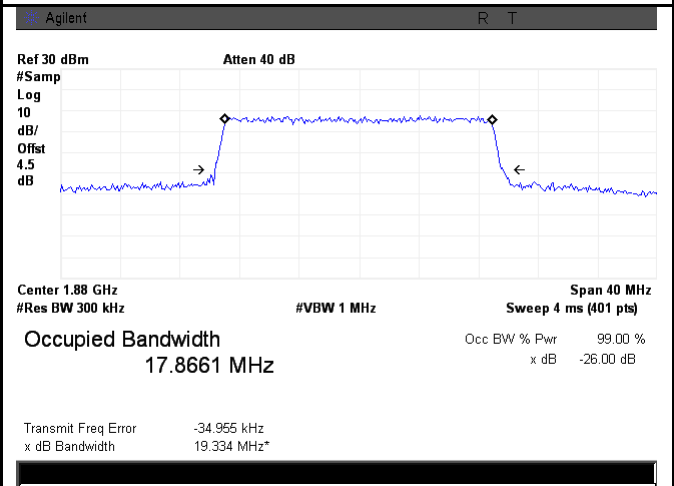

LTE band 2 - Middle CH 16QAM-20

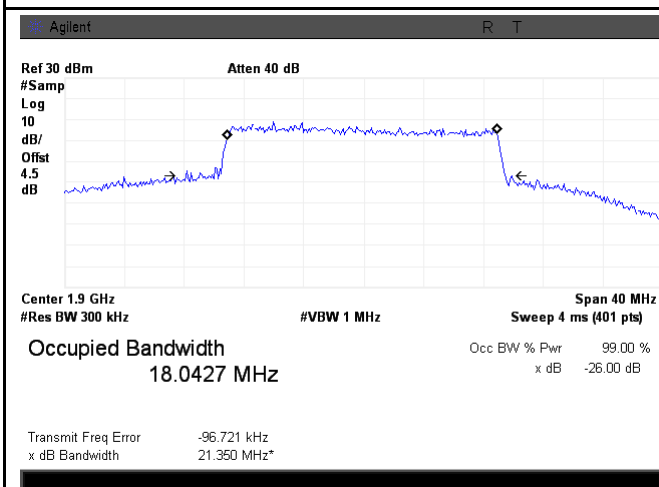

LTE band 2 - High CH QPSK-20

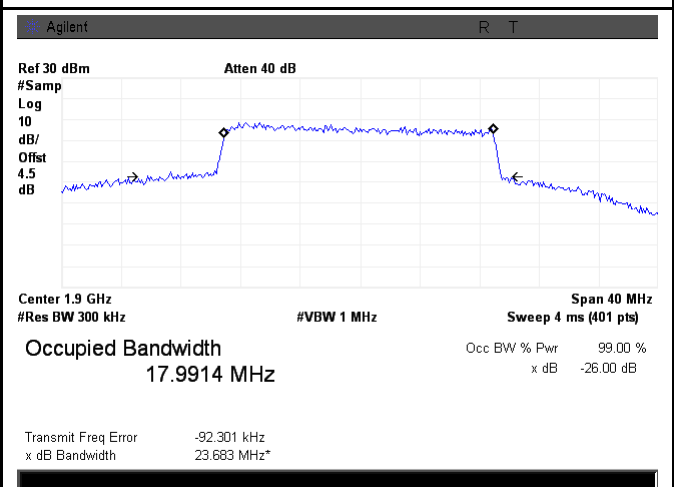

LTE band 2 - High CH 16QAM-20

LTE Band 4 (Part 27)

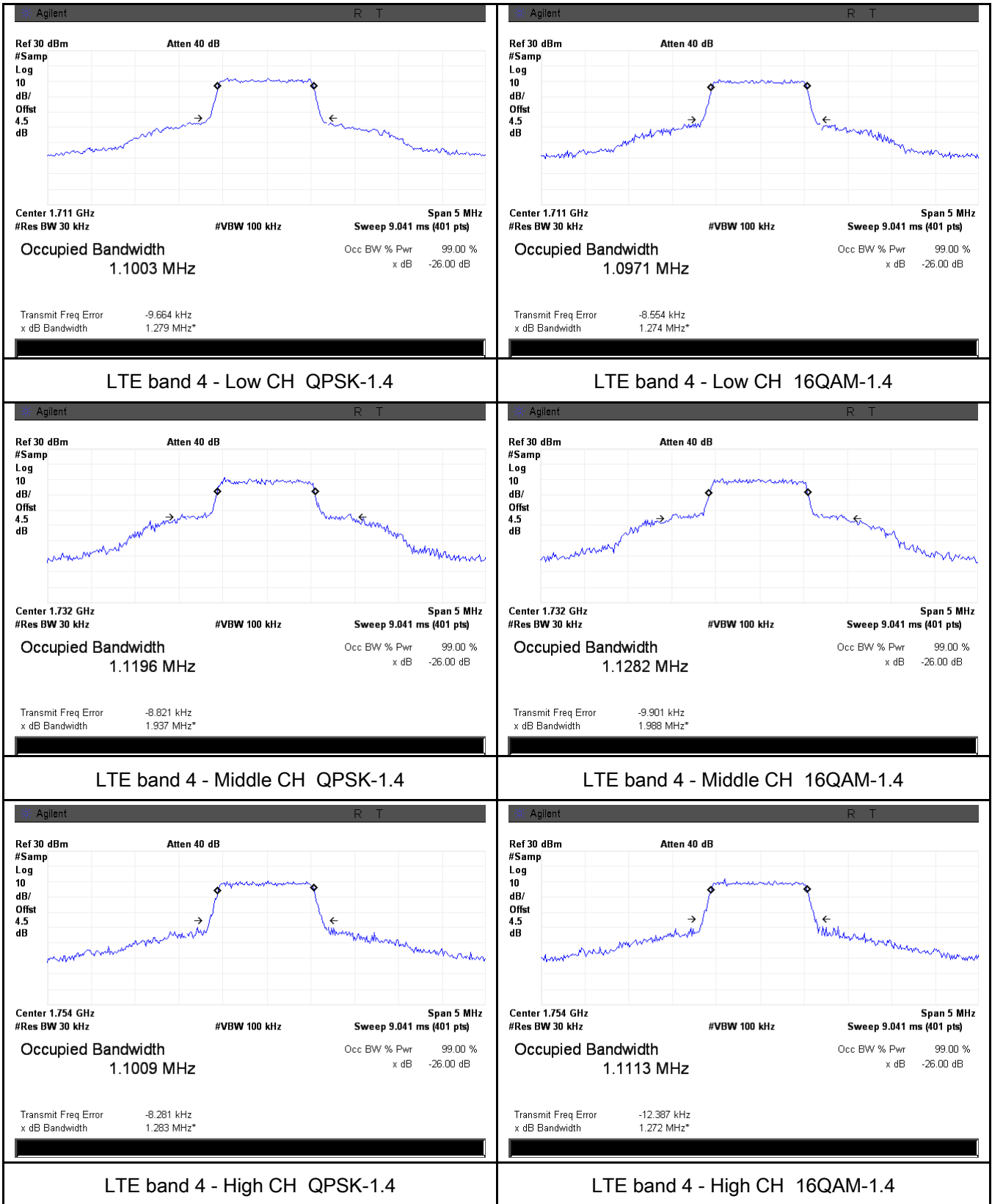

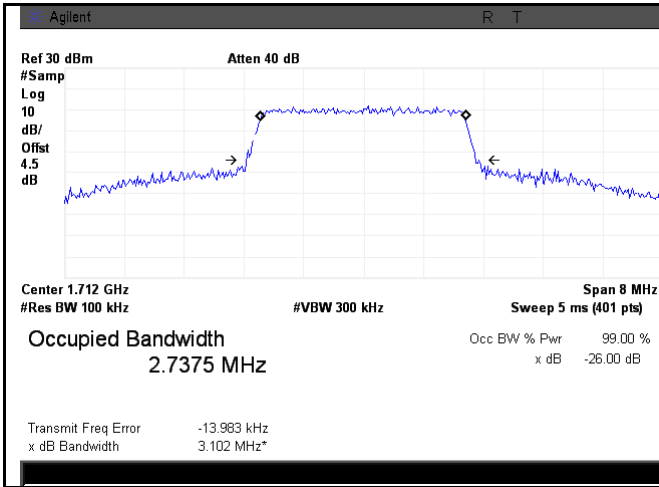

LTE band 4 - Low CH QPSK-3

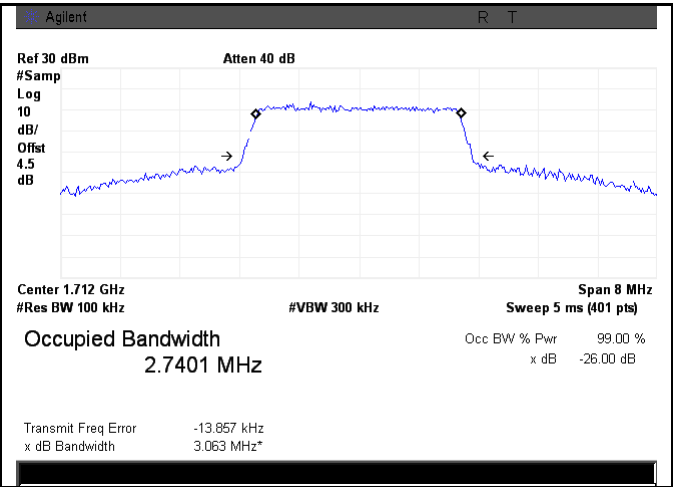

LTE band 4 - Low CH 16QAM-3

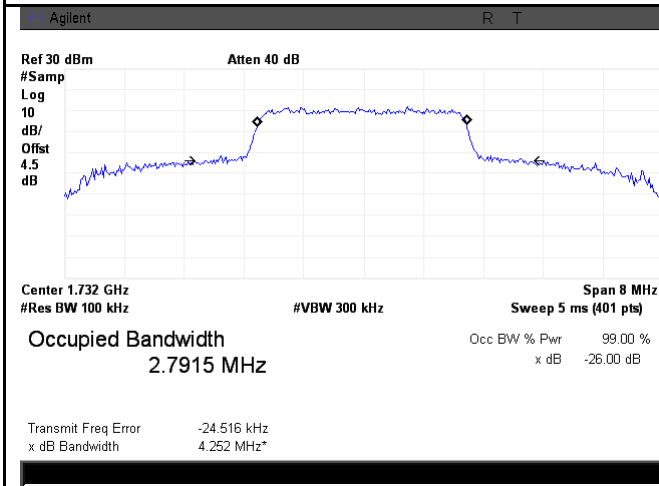

LTE band 4 - Middle CH QPSK-3

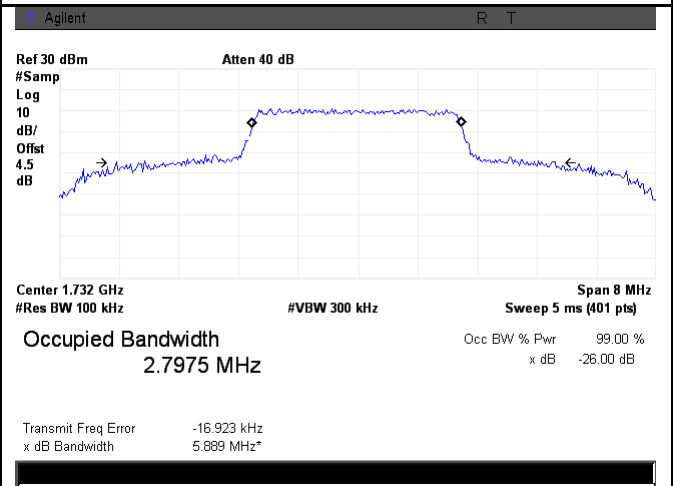

LTE band 4 - Middle CH 16QAM-3

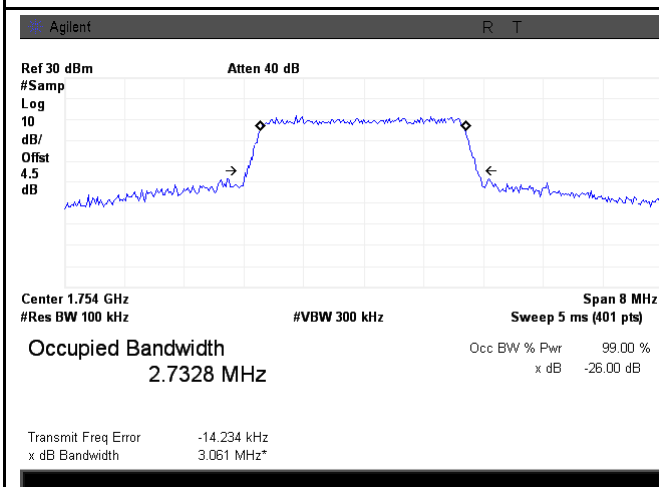

LTE band 4 - High CH QPSK-3

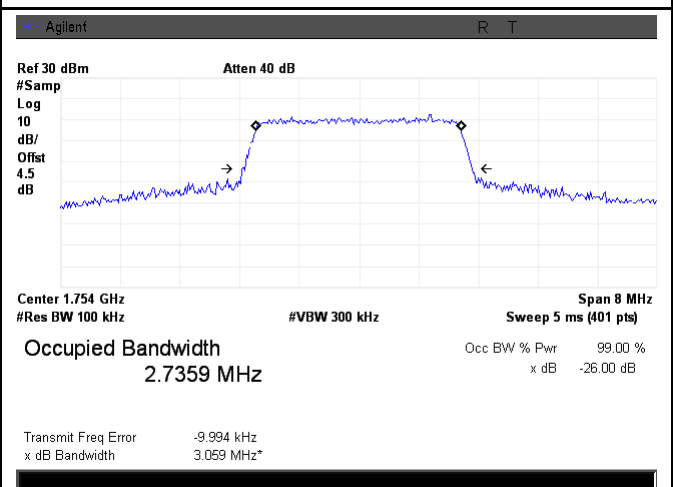

LTE band 4 - High CH 16QAM-3

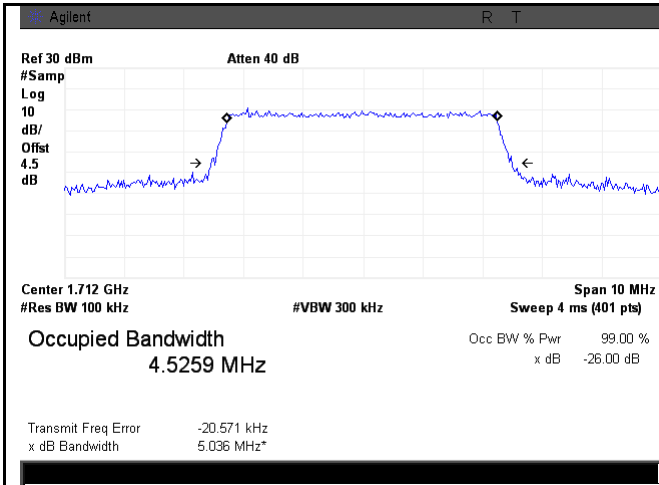

LTE band 4 - Low CH QPSK-5

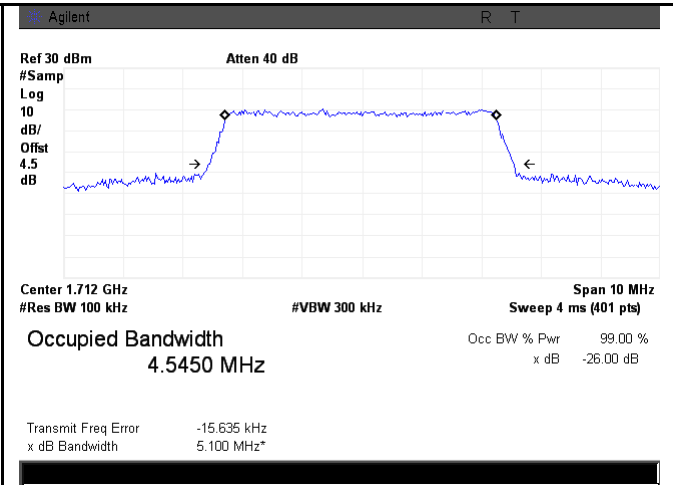

LTE band 4 - Low CH 16QAM-5

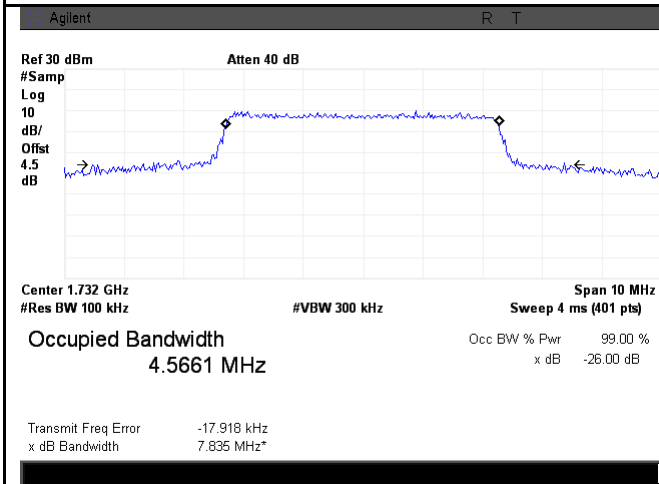

LTE band 4 - Middle CH QPSK-5

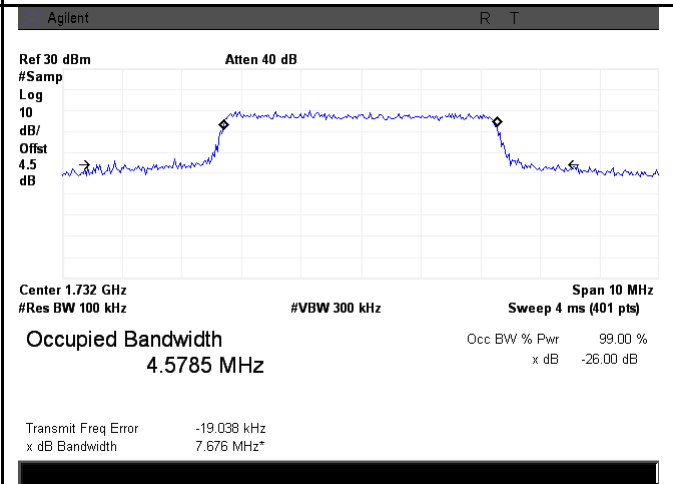

LTE band 4 - Middle CH 16QAM-5

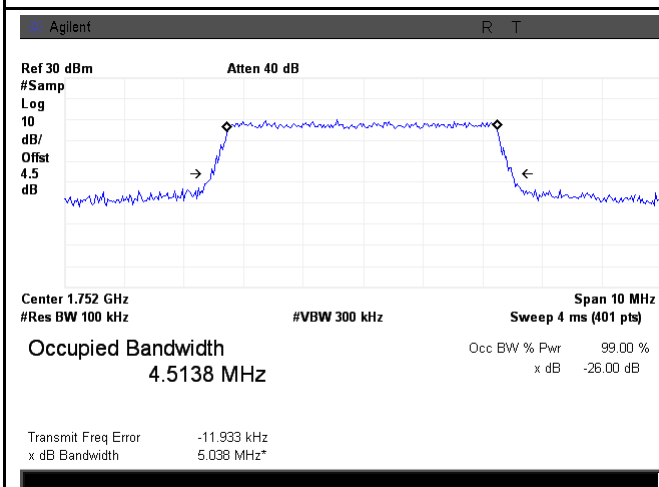

LTE band 4 - High CH QPSK-5

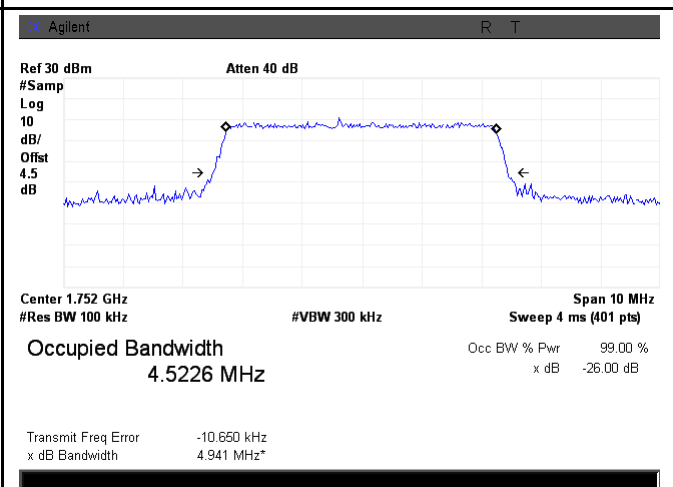

LTE band 4 - High CH 16QAM-5

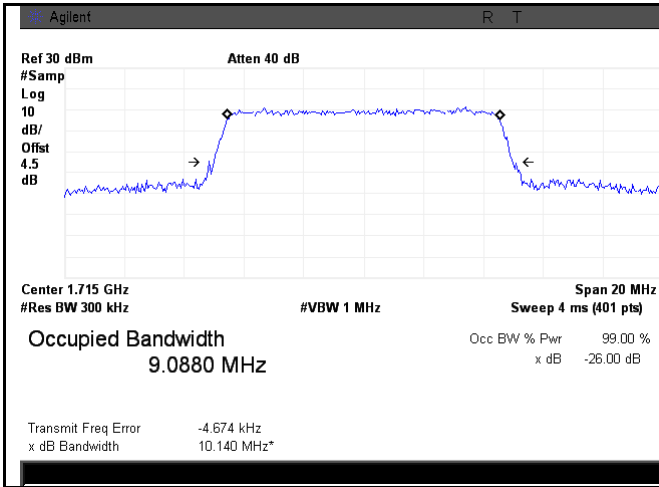

LTE band 4 - Low CH QPSK-10

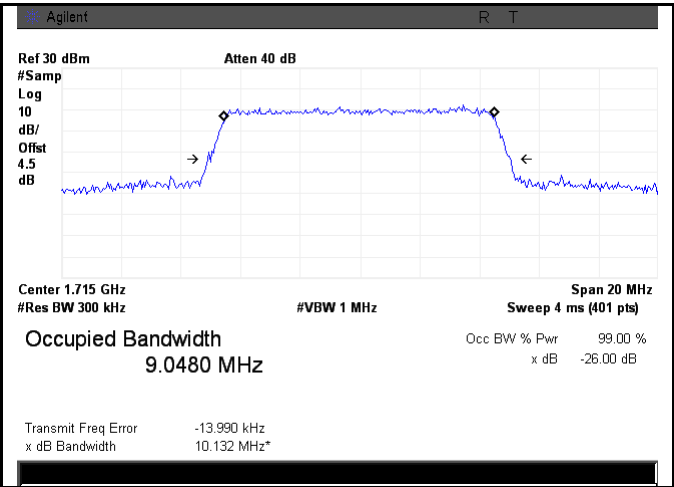

LTE band 4 - Low CH 16QAM-10

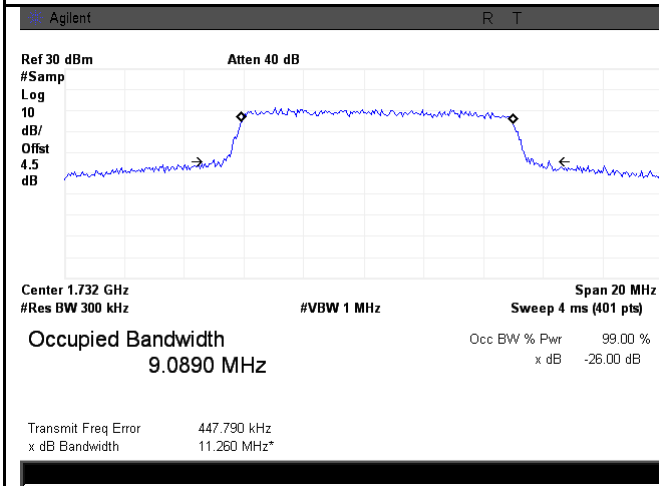

LTE band 4 - Middle CH QPSK-10

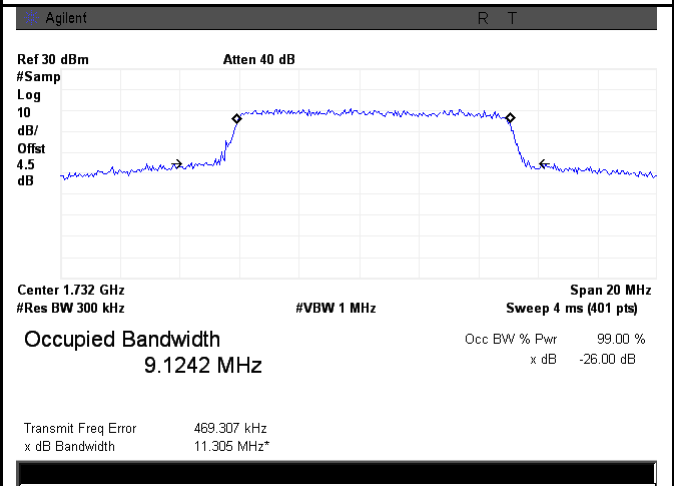

LTE band 4 - Middle CH 16QAM-10

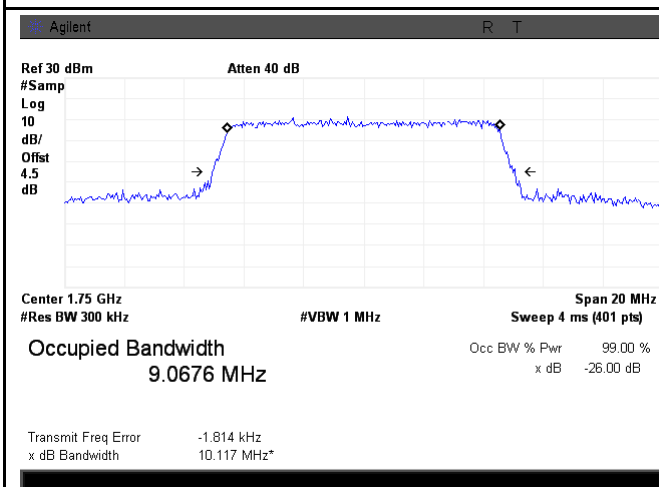

LTE band 4 - High CH QPSK-10

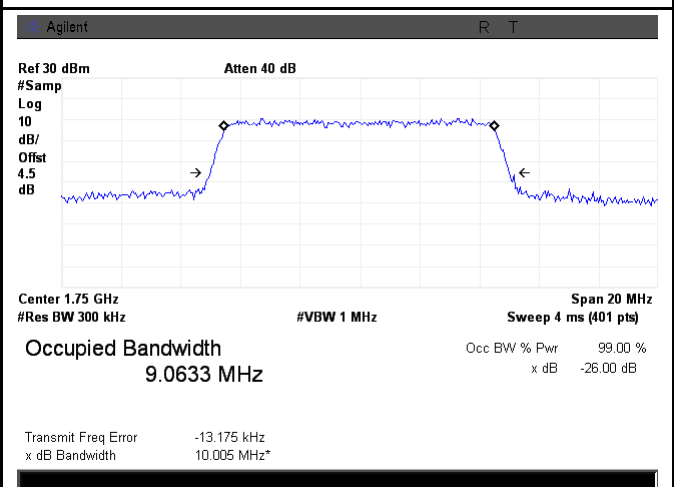

LTE band 4 - High CH 16QAM-10

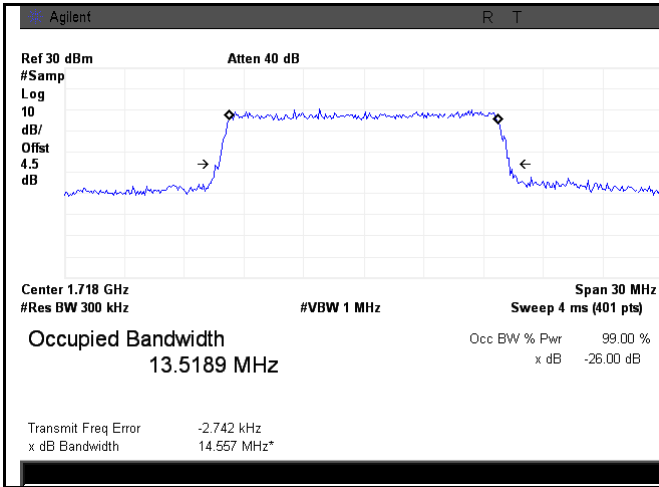

LTE band 4 - Low CH QPSK-15

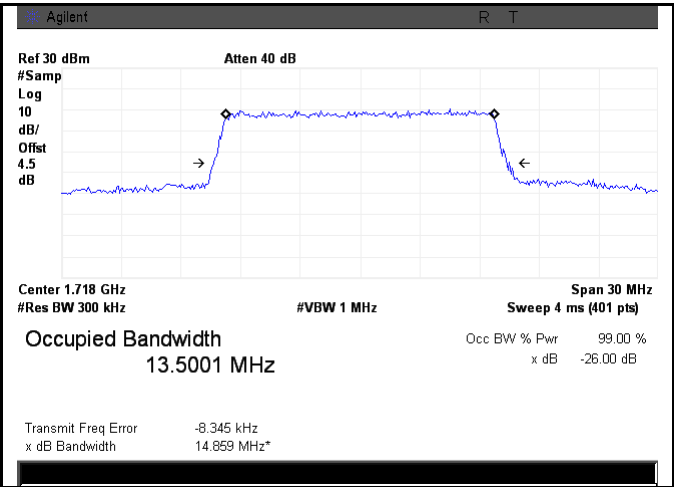

LTE band 4 - Low CH 16QAM-15

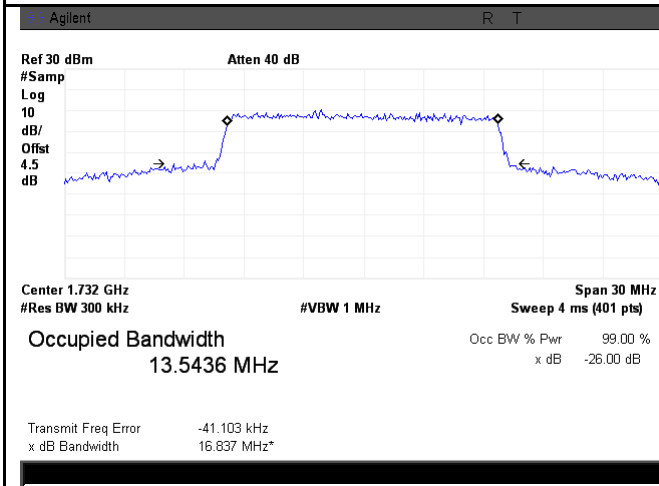

LTE band 4 - Middle CH QPSK-15

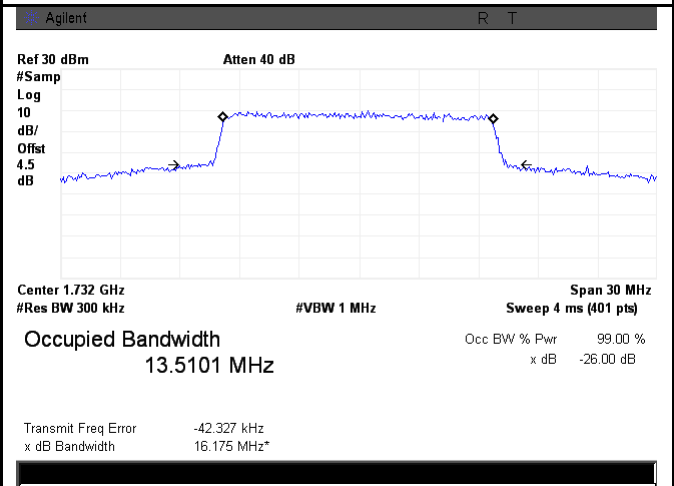

LTE band 4 - Middle CH 16QAM-15

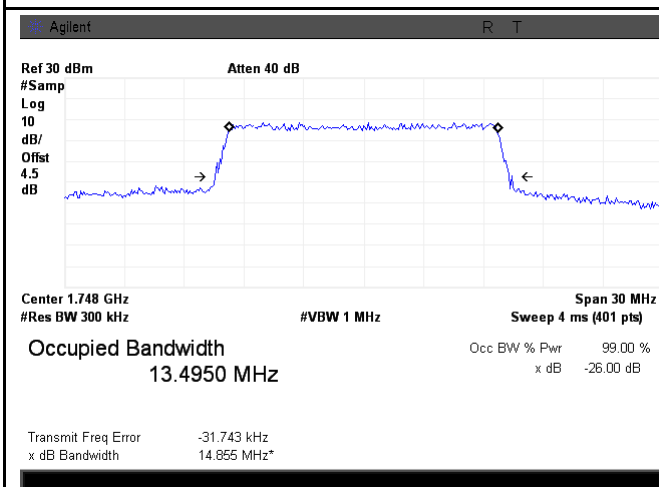

LTE band 4 - High CH QPSK-15

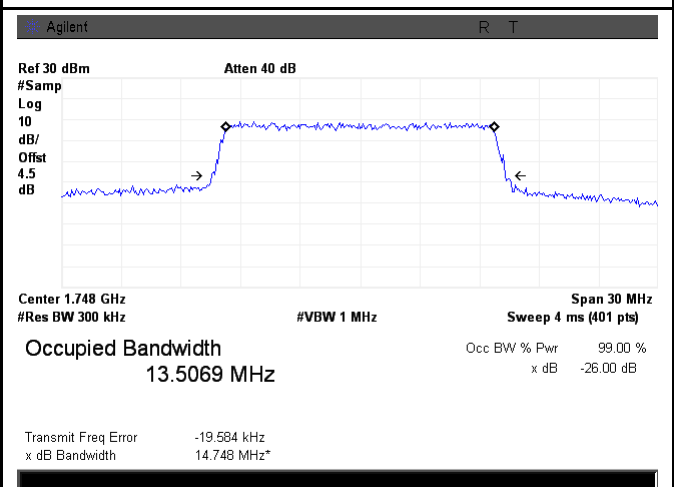

LTE band 4 - High CH 16QAM-15

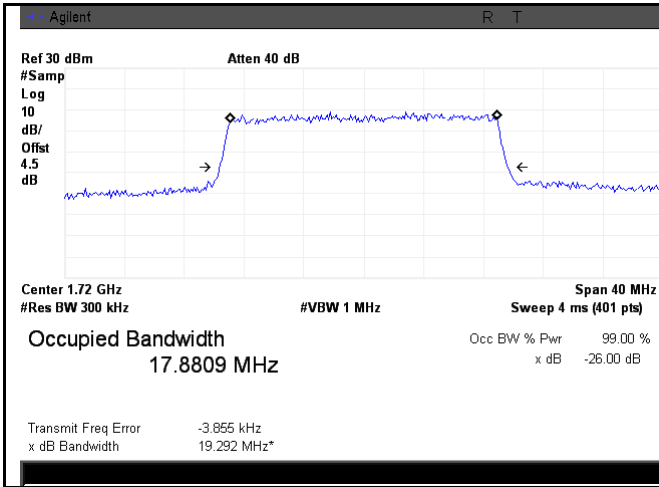

LTE band 4 - Low CH QPSK-20

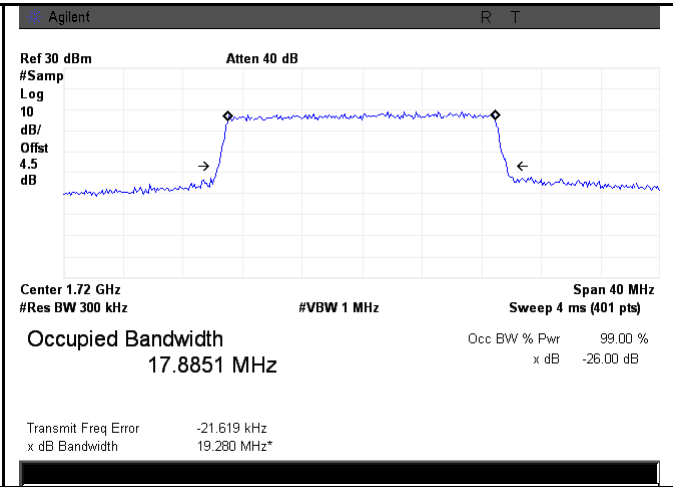

LTE band 4 - Low CH 16QAM-20

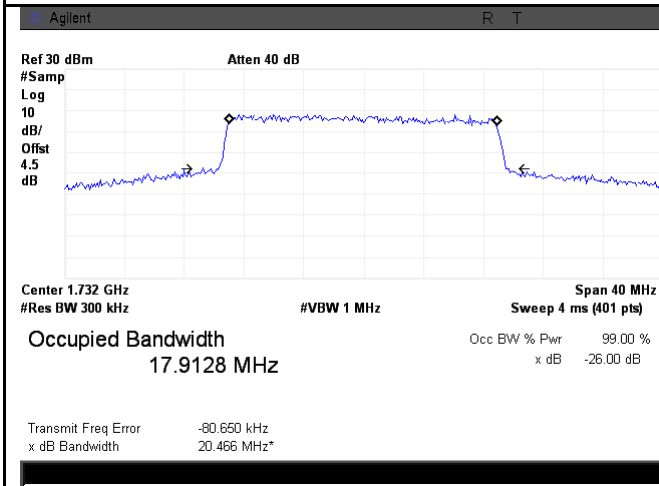

LTE band 4 - Middle CH QPSK-20

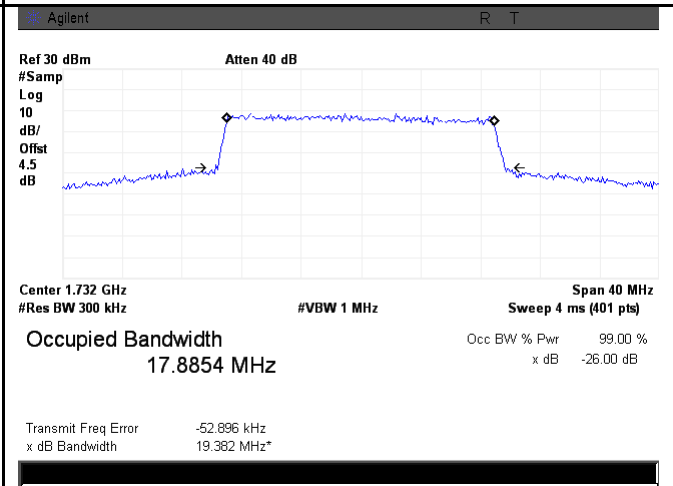

LTE band 4 - Middle CH 16QAM-20

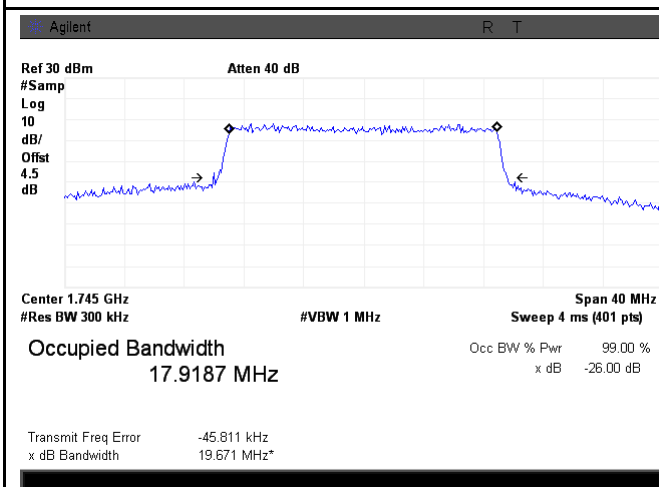

LTE band 4 - High CH QPSK-20

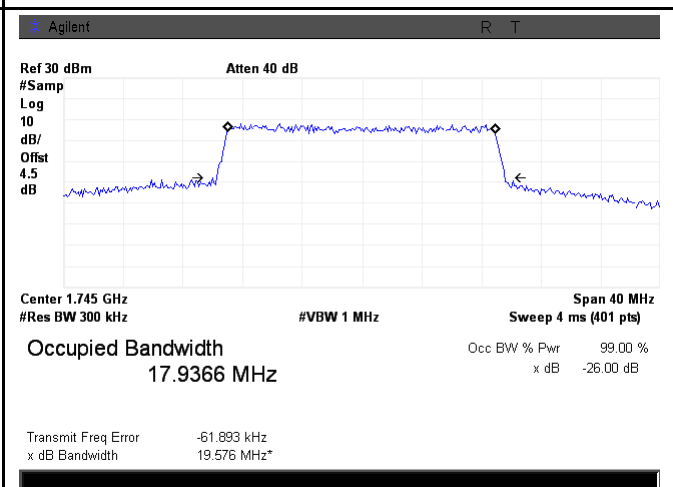

LTE band 4 - High CH 16QAM-20

LTE Band 5 (Part 22H)

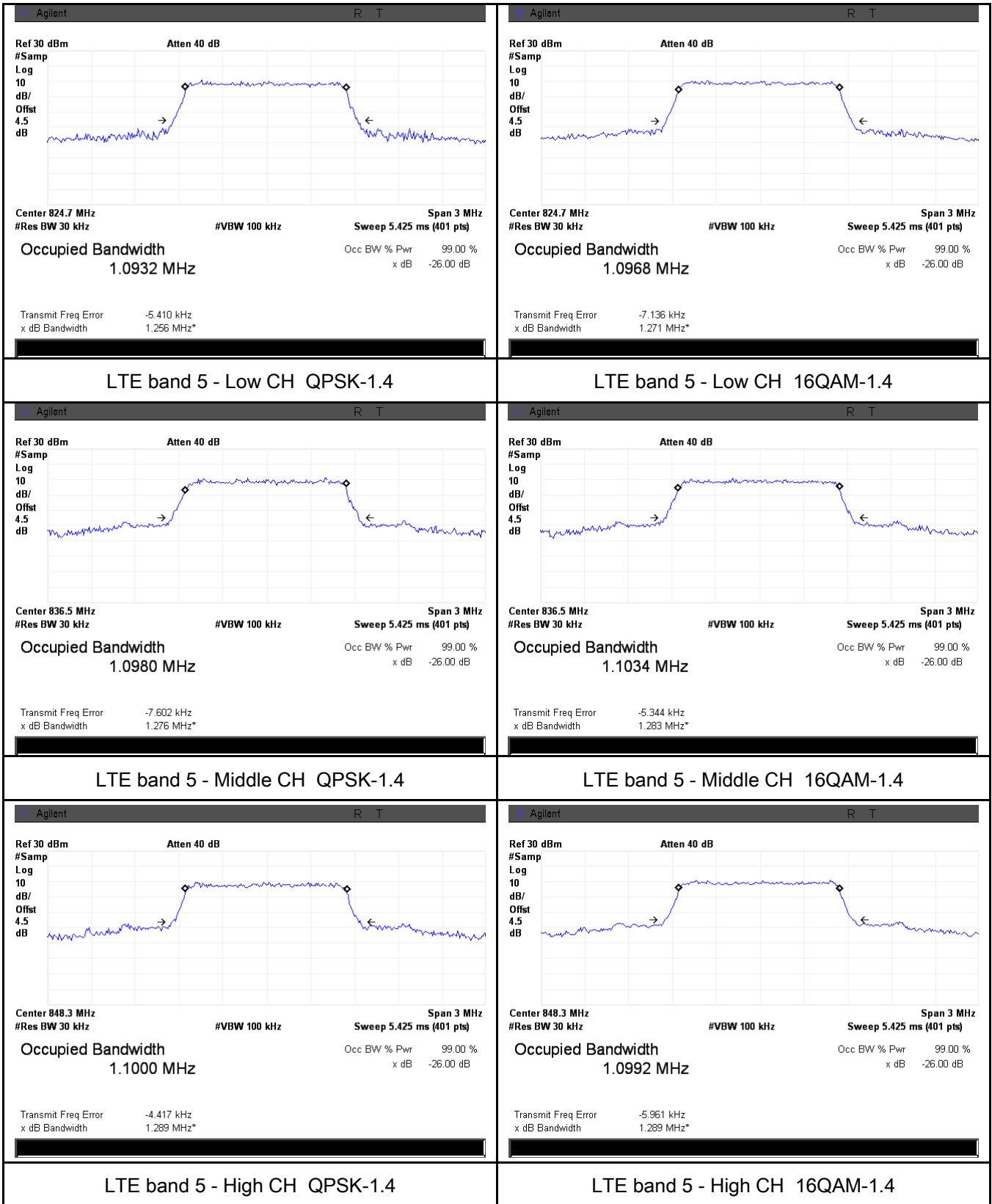

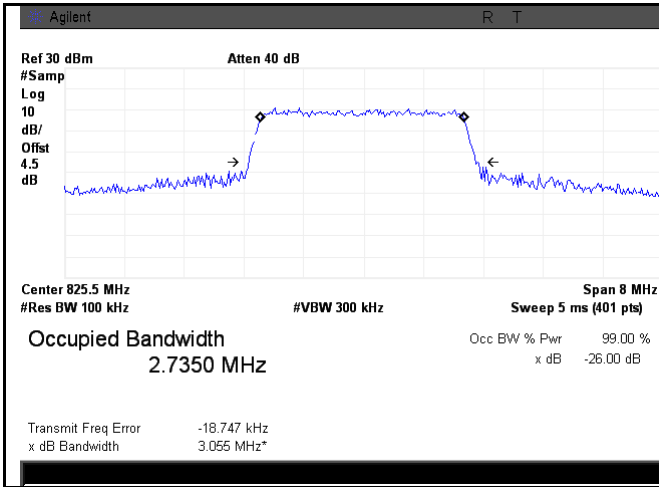

LTE band 5 - Low CH QPSK-3

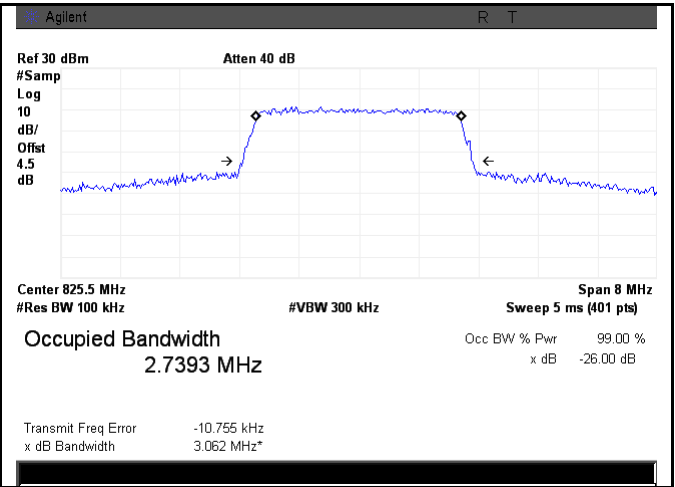

LTE band 5 - Low CH 16QAM-3

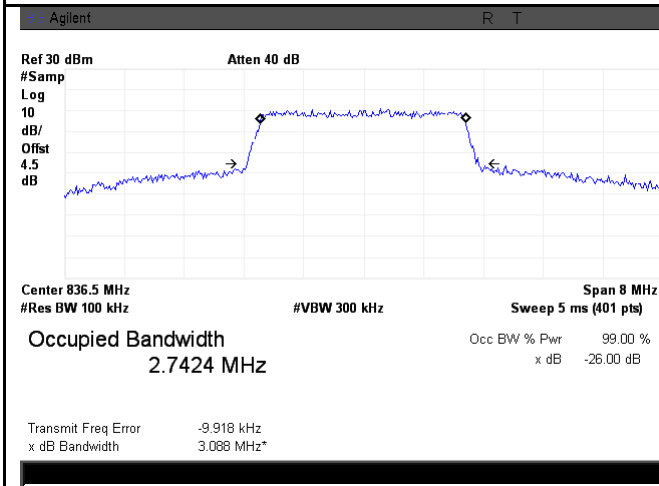

LTE band 5 - Middle CH QPSK-3

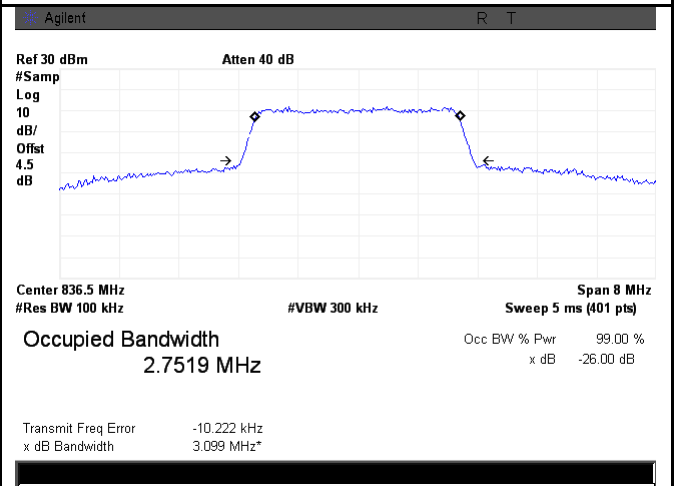

LTE band 5 - Middle CH 16QAM-3

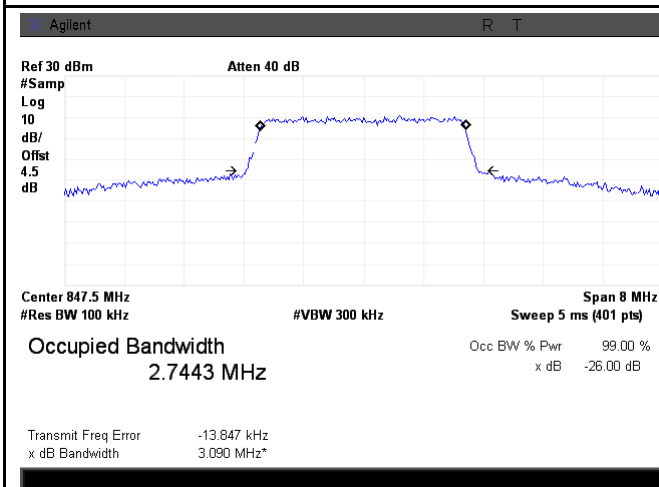

LTE band 5 - High CH QPSK-3

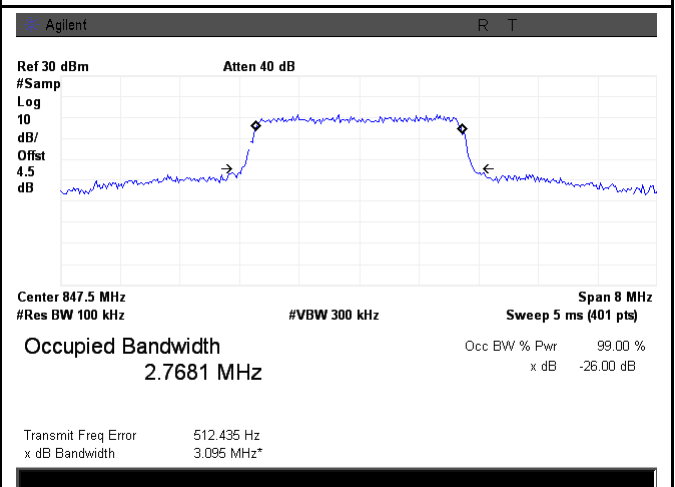

LTE band 5 - High CH 16QAM-3

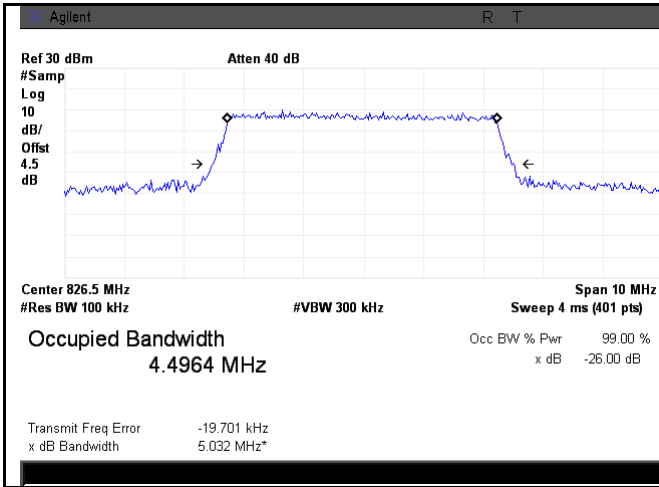

LTE band 5 - Low CH QPSK-5

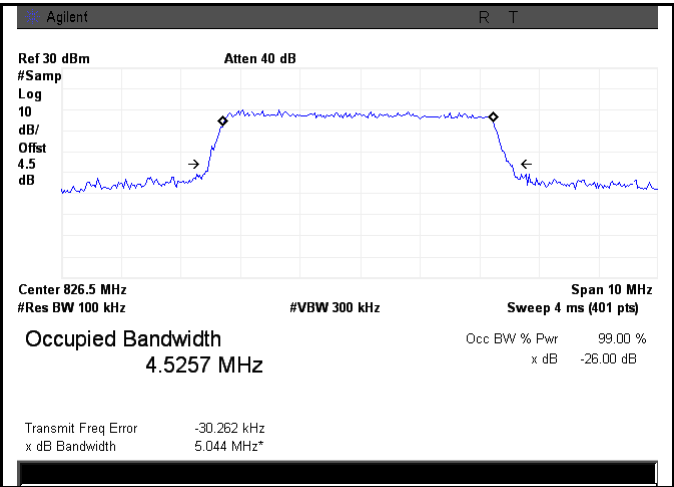

LTE band 5 - Low CH 16QAM-5

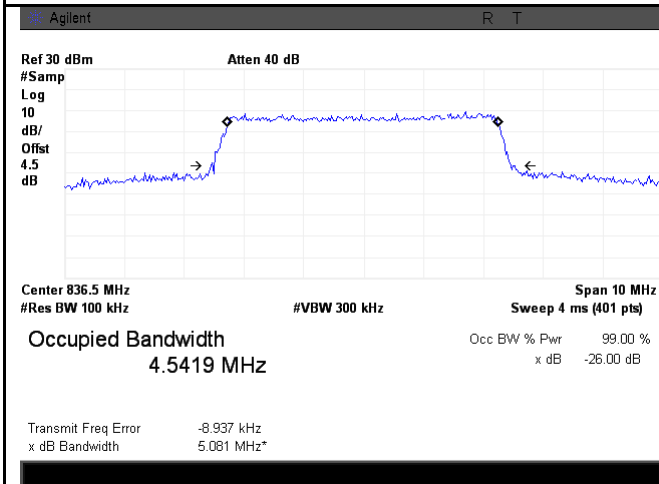

LTE band 5 - Middle CH QPSK-5

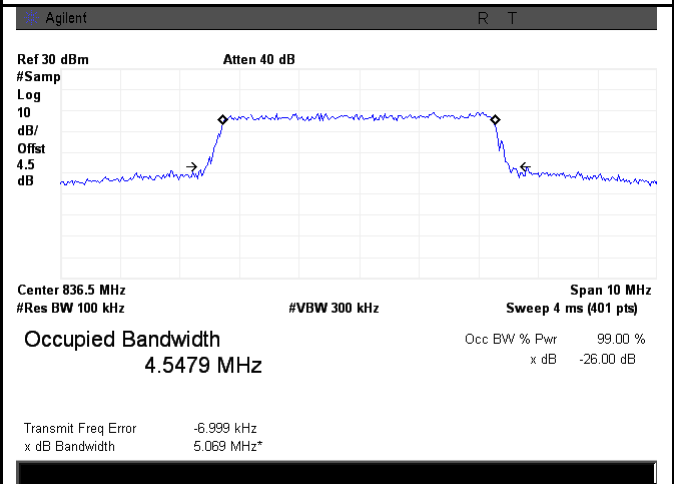

LTE band 5 - Middle CH 16QAM-5

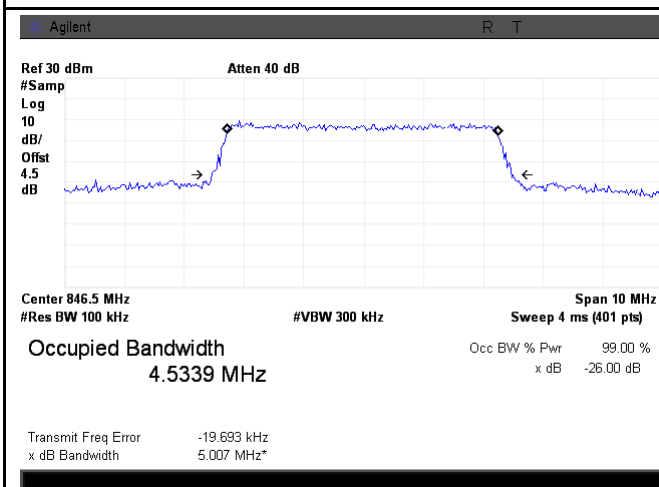

LTE band 5 - High CH QPSK-5

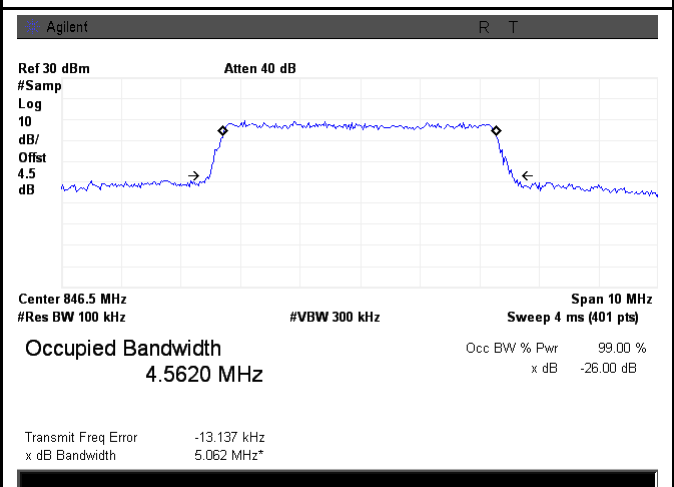

LTE band 5 - High CH 16QAM-5

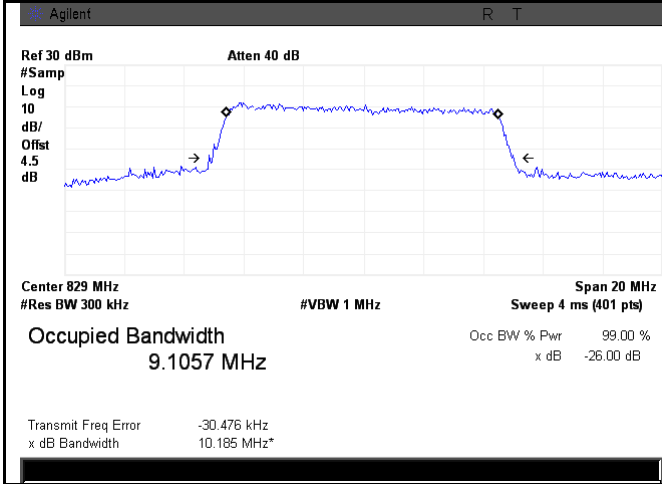

LTE band 5 - Low CH QPSK-10

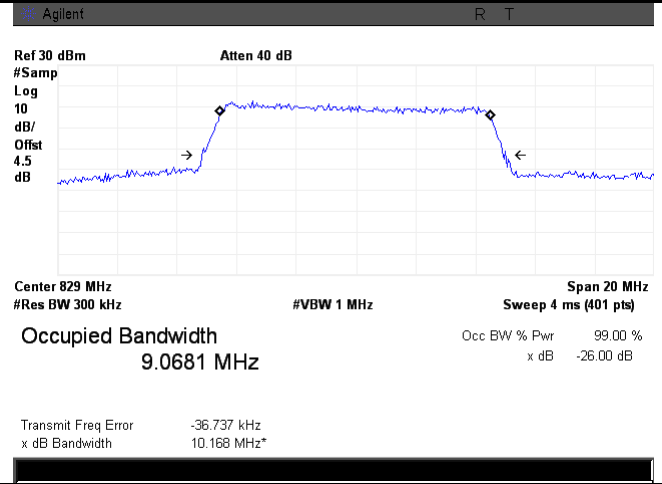

LTE band 5 - Low CH 16QAM-10

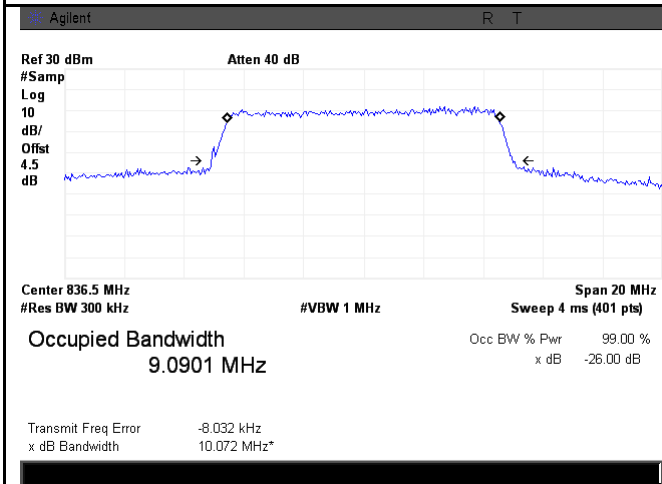

LTE band 5 - Middle CH QPSK-10

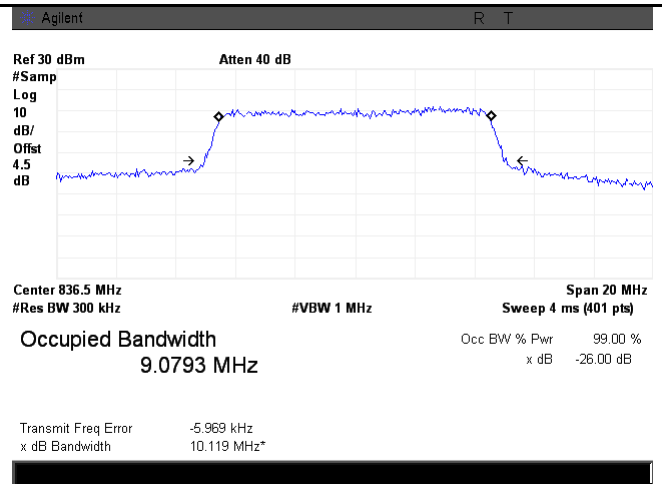

LTE band 5 - Middle CH 16QAM-10

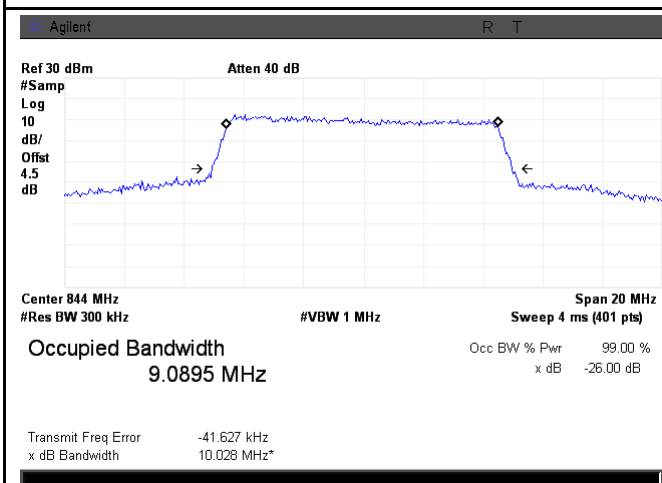

LTE band 5 - High CH QPSK-10

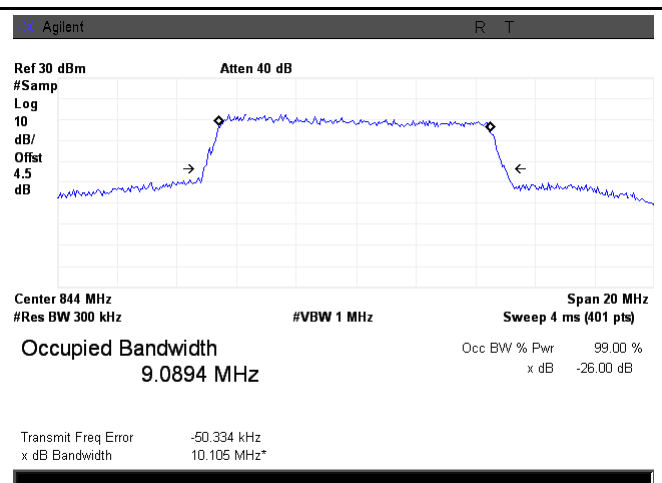

LTE band 5 - High CH 16QAM-10

LTE Band 7 (Part 27)

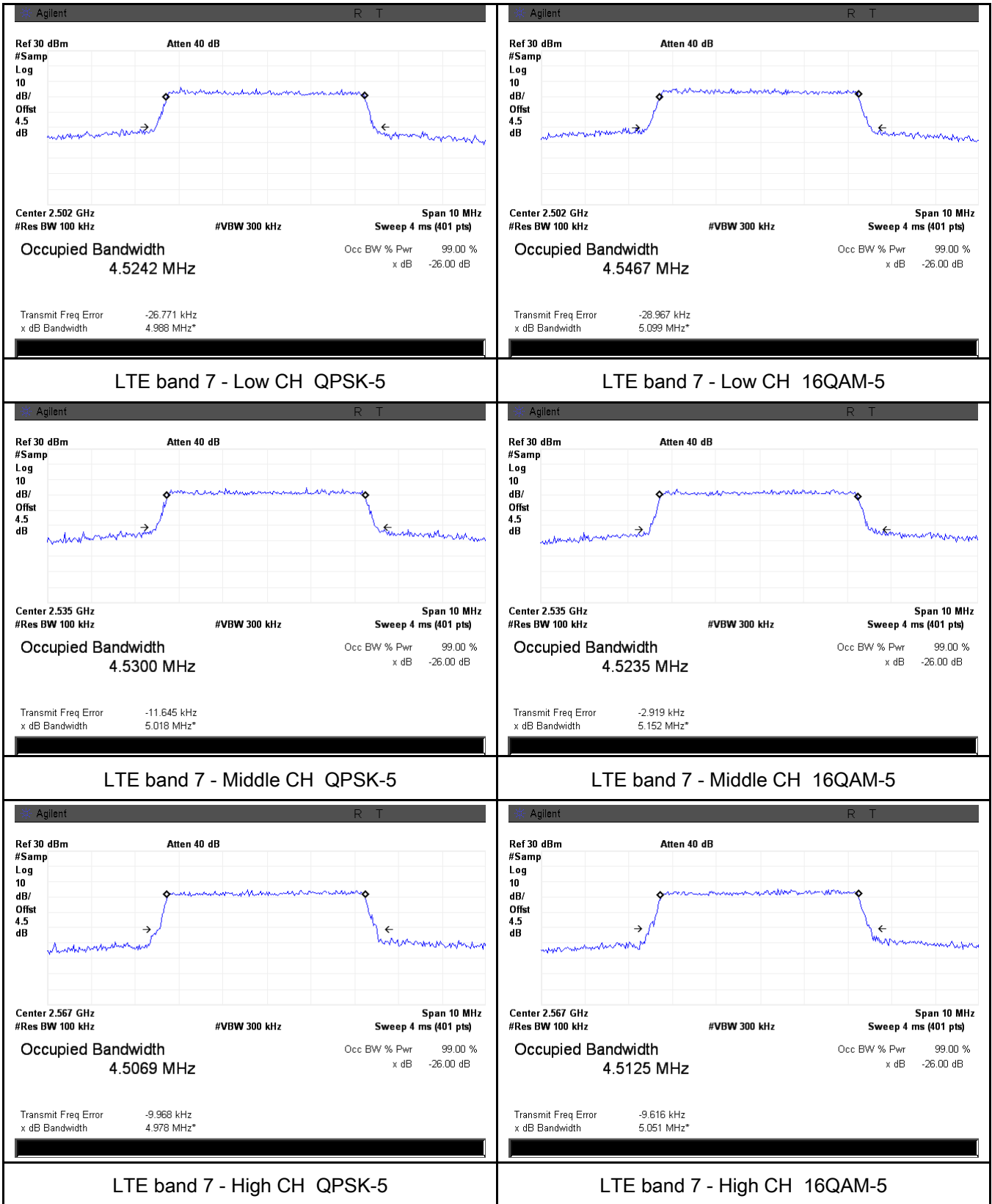

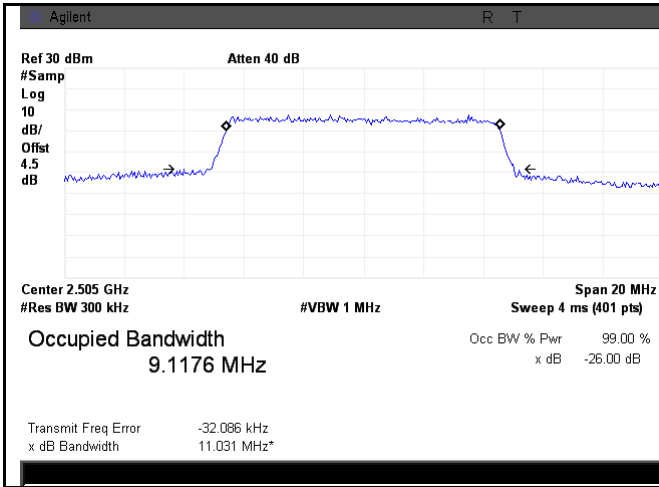

LTE band 7 - Low CH QPSK-10

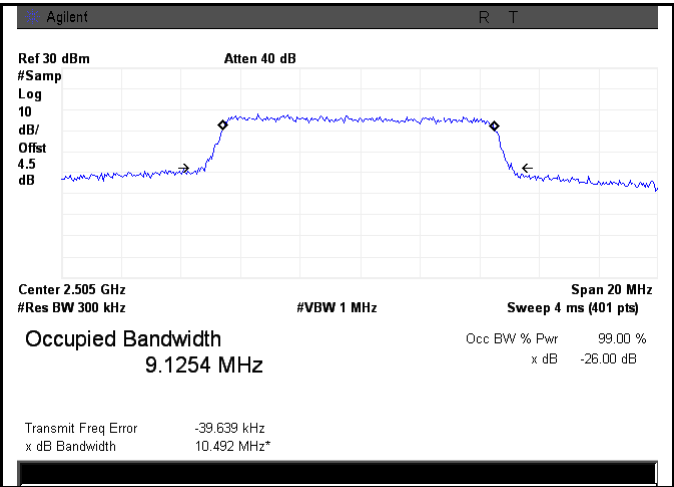

LTE band 7 - Low CH 16QAM-10

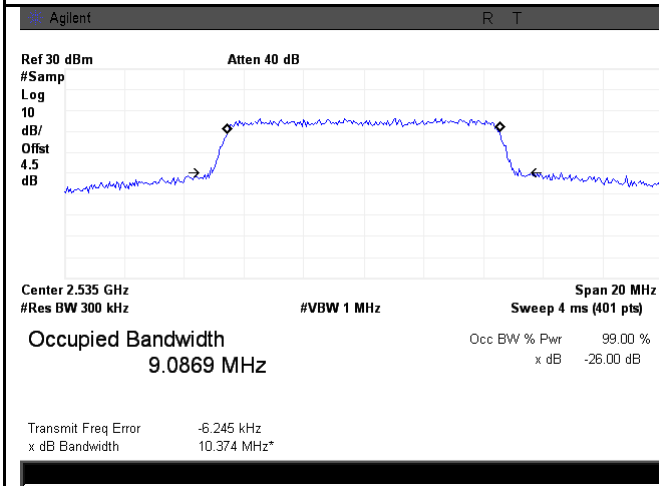

LTE band 7 - Middle CH QPSK-10

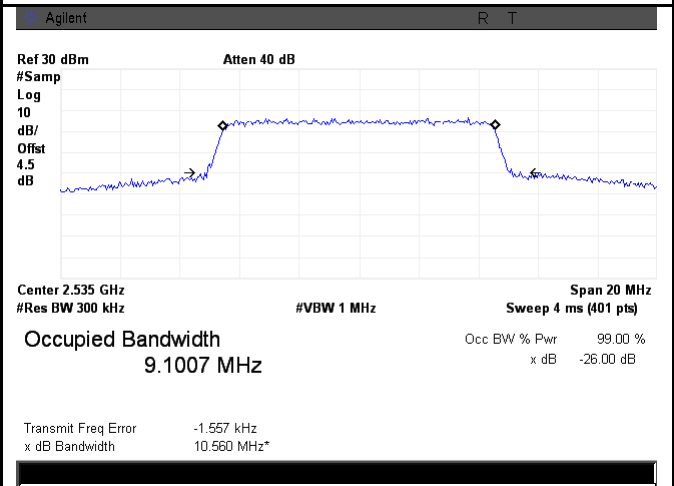

LTE band 7 - Middle CH 16QAM-10

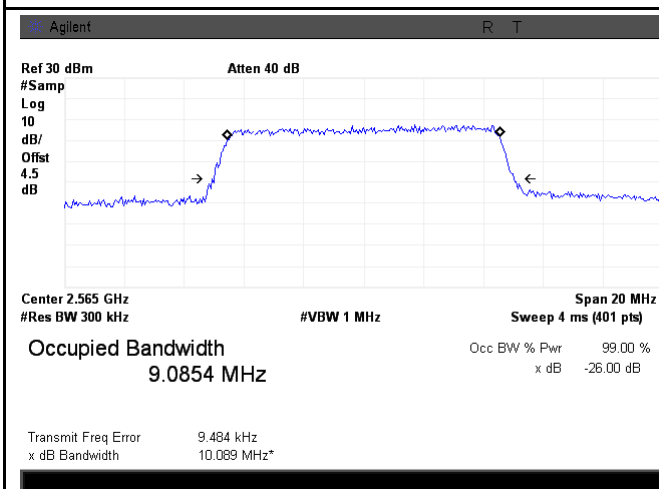

LTE band 7 - High CH QPSK-10

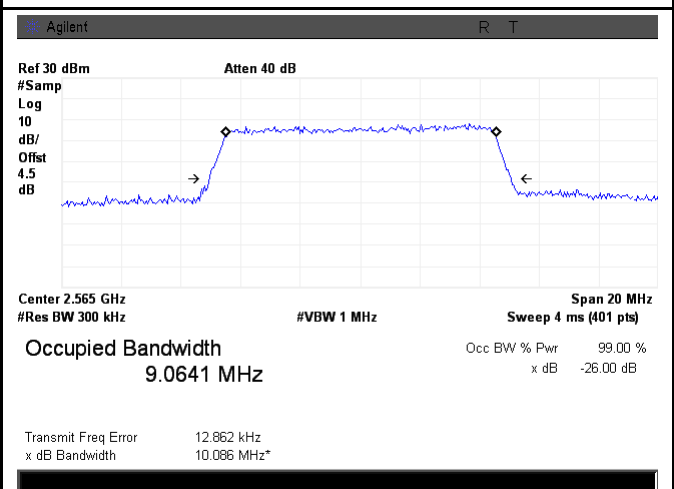

LTE band 7 - High CH 16QAM-10

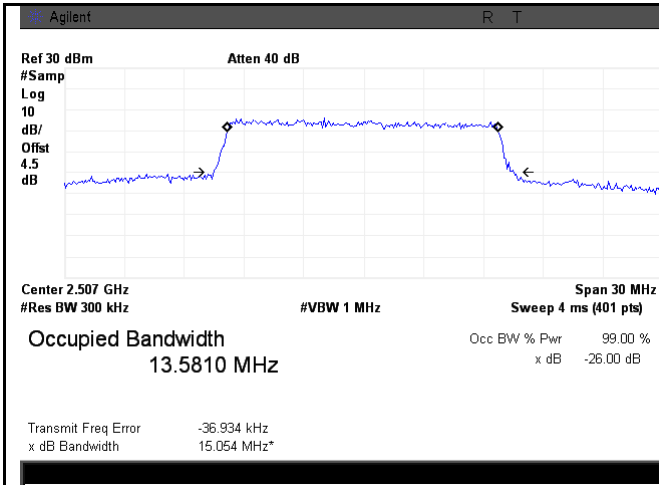

LTE band 7 - Low CH QPSK-15

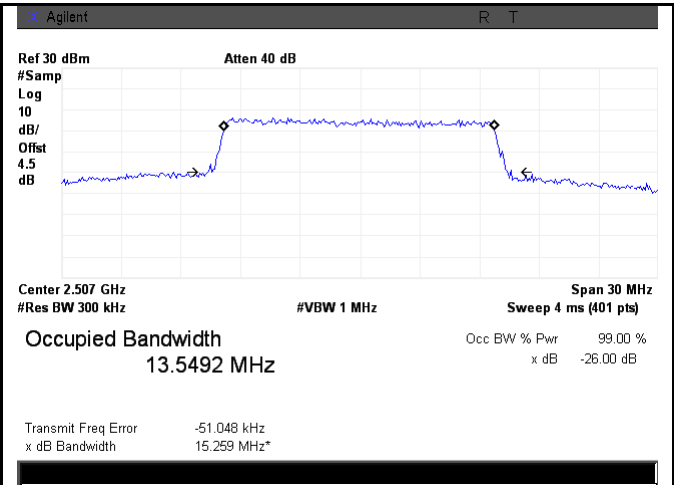

LTE band 7 - Low CH 16QAM-15

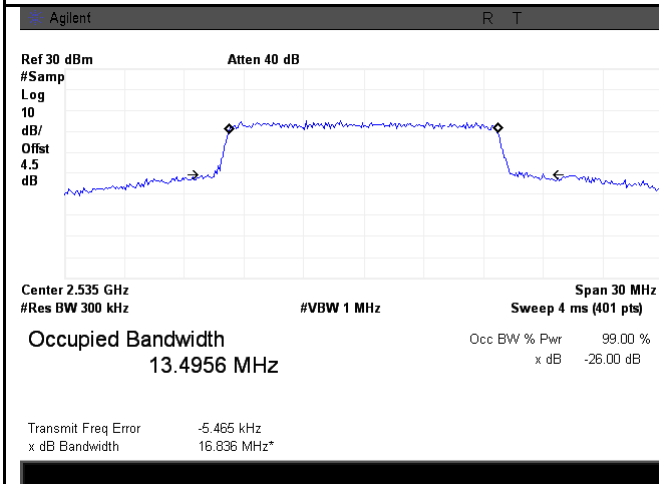

LTE band 7 - Middle CH QPSK-15

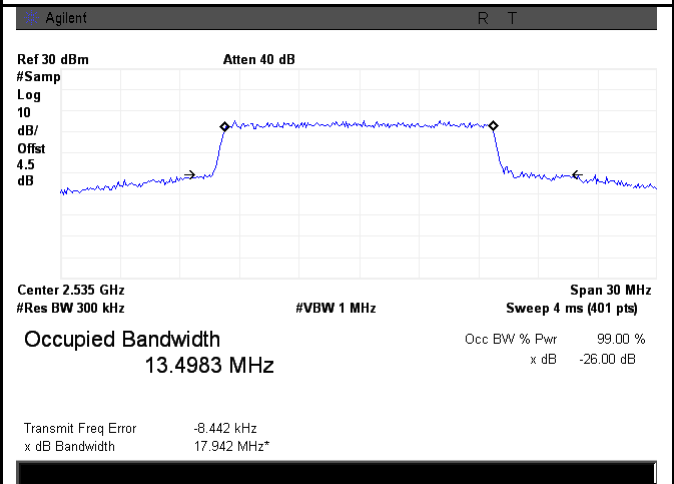

LTE band 7 - Middle CH 16QAM-15

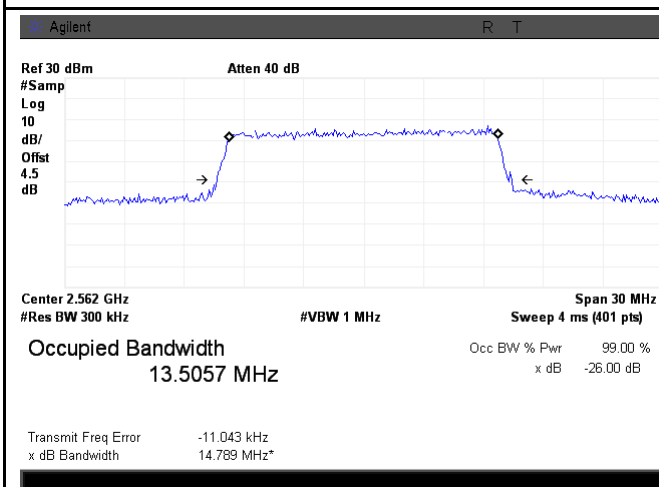

LTE band 7 - High CH QPSK-15

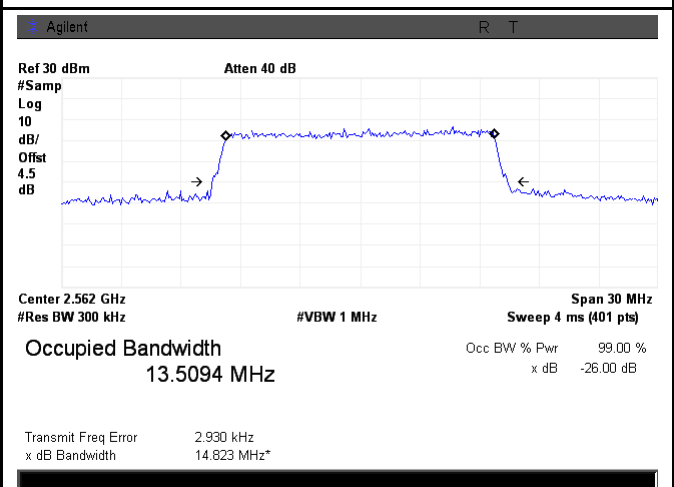

LTE band 7 - High CH 16QAM-15

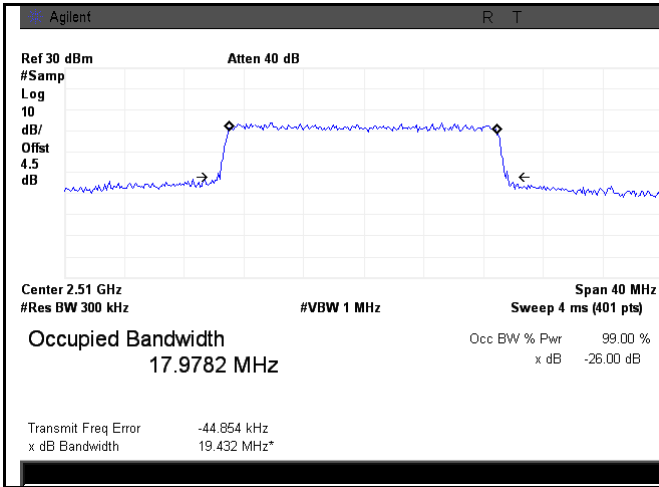

LTE band 7 - Low CH QPSK-20

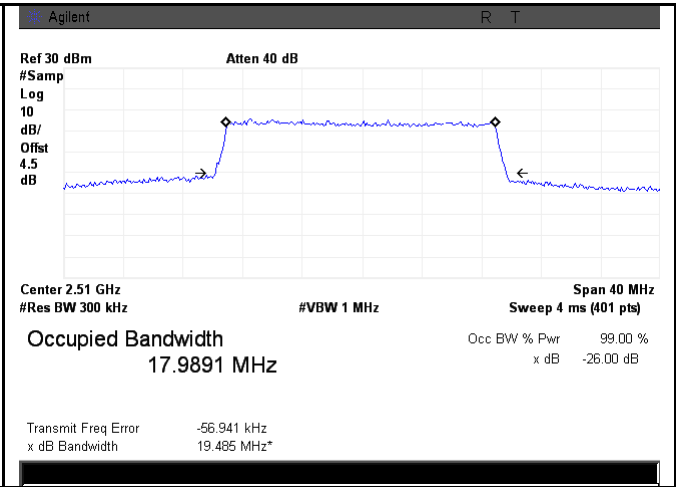

LTE band 7 - Low CH 16QAM-20

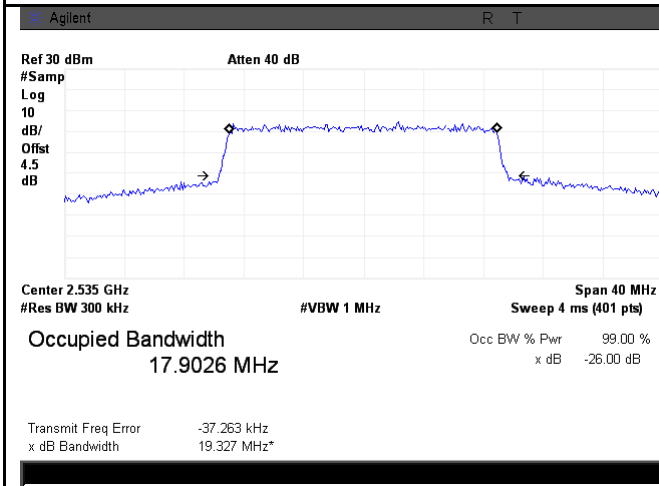

LTE band 7 - Middle CH QPSK-20

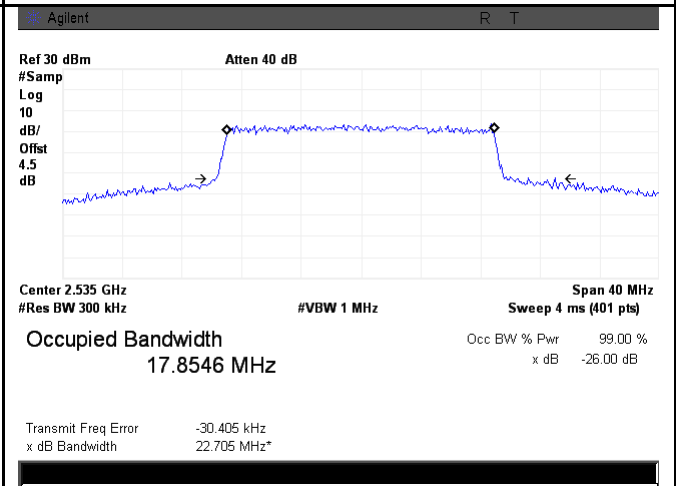

LTE band 7 - Middle CH 16QAM-20

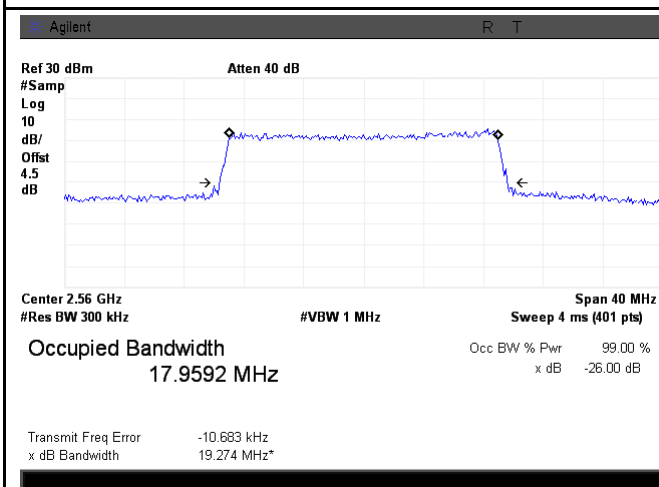

LTE band 7 - High CH QPSK-20

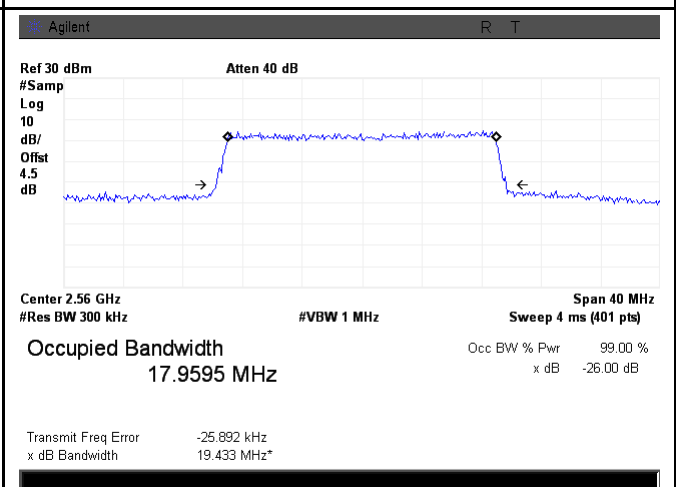

LTE band 7 - High CH 16QAM-20

LTE Band 17 (Part 27)

<p>Agilent R T</p> <p>Ref 30 dBm #Samp Log 10 dB/ Offset 4 dB</p> <p>Atten 40 dB</p> <p>Center 706.5 MHz #Res BW 100 kHz #VBW 300 kHz Span 10 MHz Sweep 4 ms (401 pts)</p> <p>Occupied Bandwidth 4.5121 MHz</p> <p>Occ BW % Pwr 99.00 % x dB -26.00 dB</p> <p>Transmit Freq Error -16.207 kHz x dB Bandwidth 4.979 MHz*</p>	<p>Agilent R T</p> <p>Ref 30 dBm #Samp Log 10 dB/ Offset 4 dB</p> <p>Atten 40 dB</p> <p>Center 706.5 MHz #Res BW 100 kHz #VBW 300 kHz Span 10 MHz Sweep 4 ms (401 pts)</p> <p>Occupied Bandwidth 4.5086 MHz</p> <p>Occ BW % Pwr 99.00 % x dB -26.00 dB</p> <p>Transmit Freq Error -18.160 kHz x dB Bandwidth 5.019 MHz*</p>
<p>LTE band 17 - Low CH QPSK-5</p>	<p>LTE band 17 - Low CH 16QAM-5</p>
<p>Agilent R T</p> <p>Ref 30 dBm #Samp Log 10 dB/ Offset 4 dB</p> <p>Atten 40 dB</p> <p>Center 710 MHz #Res BW 100 kHz #VBW 300 kHz Span 10 MHz Sweep 4 ms (401 pts)</p> <p>Occupied Bandwidth 4.5315 MHz</p> <p>Occ BW % Pwr 99.00 % x dB -26.00 dB</p> <p>Transmit Freq Error -21.492 kHz x dB Bandwidth 5.042 MHz*</p>	<p>Agilent R T</p> <p>Ref 30 dBm #Samp Log 10 dB/ Offset 4 dB</p> <p>Atten 40 dB</p> <p>Center 710 MHz #Res BW 100 kHz #VBW 300 kHz Span 10 MHz Sweep 4 ms (401 pts)</p> <p>Occupied Bandwidth 4.5242 MHz</p> <p>Occ BW % Pwr 99.00 % x dB -26.00 dB</p> <p>Transmit Freq Error -13.291 kHz x dB Bandwidth 5.030 MHz*</p>
<p>LTE band 17 - Middle CH QPSK-5</p>	<p>LTE band 17 - Middle CH 16QAM-5</p>
<p>Agilent R T</p> <p>Ref 30 dBm #Samp Log 10 dB/ Offset 4 dB</p> <p>Atten 40 dB</p> <p>Center 713.5 MHz #Res BW 100 kHz #VBW 300 kHz Span 10 MHz Sweep 4 ms (401 pts)</p> <p>Occupied Bandwidth 4.5354 MHz</p> <p>Occ BW % Pwr 99.00 % x dB -26.00 dB</p> <p>Transmit Freq Error -17.846 kHz x dB Bandwidth 5.063 MHz*</p>	<p>Agilent R T</p> <p>Ref 30 dBm #Samp Log 10 dB/ Offset 4 dB</p> <p>Atten 40 dB</p> <p>Center 713.5 MHz #Res BW 100 kHz #VBW 300 kHz Span 10 MHz Sweep 4 ms (401 pts)</p> <p>Occupied Bandwidth 4.5153 MHz</p> <p>Occ BW % Pwr 99.00 % x dB -26.00 dB</p> <p>Transmit Freq Error -15.128 kHz x dB Bandwidth 5.011 MHz*</p>
<p>LTE band 17 - High CH QPSK-5</p>	<p>LTE band 17 - High CH 16QAM-5</p>

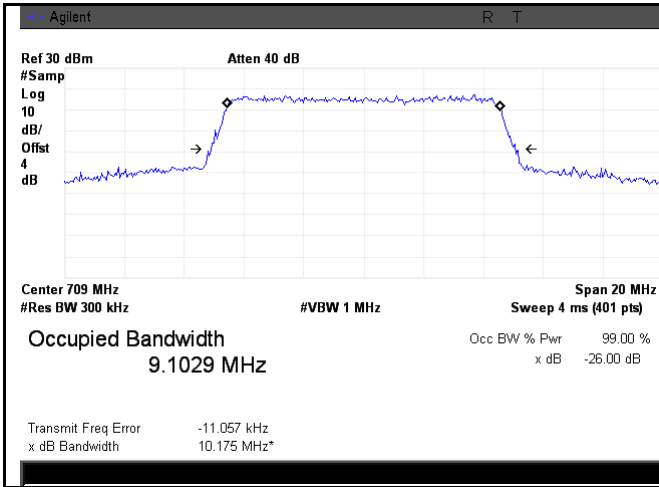

LTE band 17 - Low CH QPSK-10

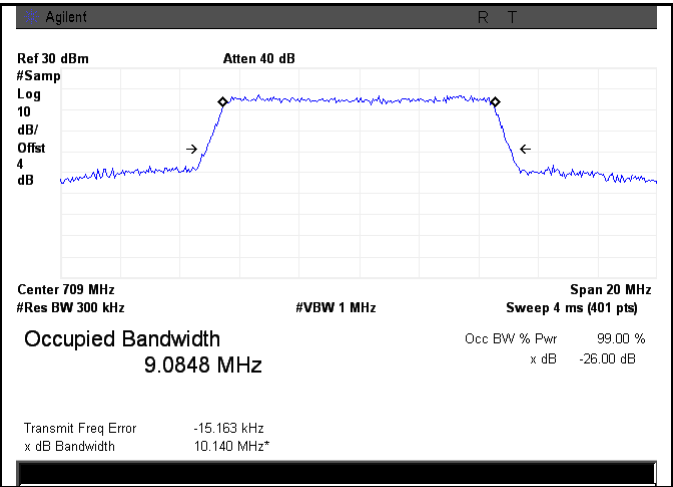

LTE band 17 - Low CH 16QAM-10

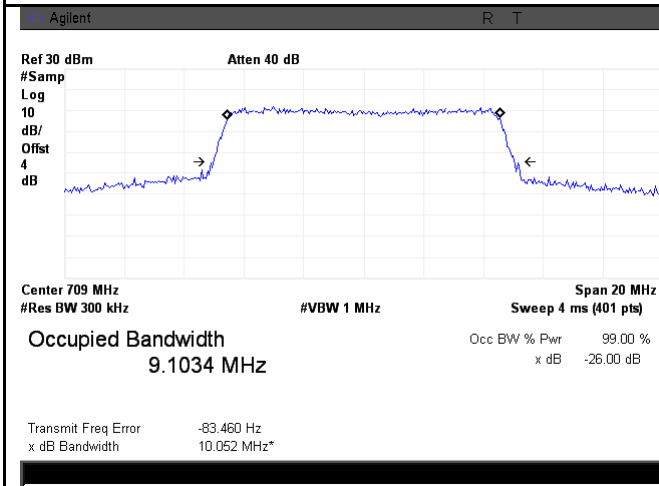

LTE band 17 - Middle CH QPSK-10

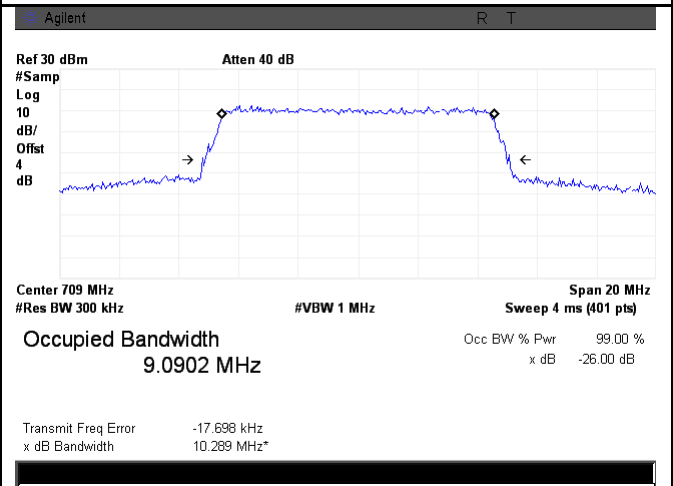

LTE band 17 - Middle CH 16QAM-10

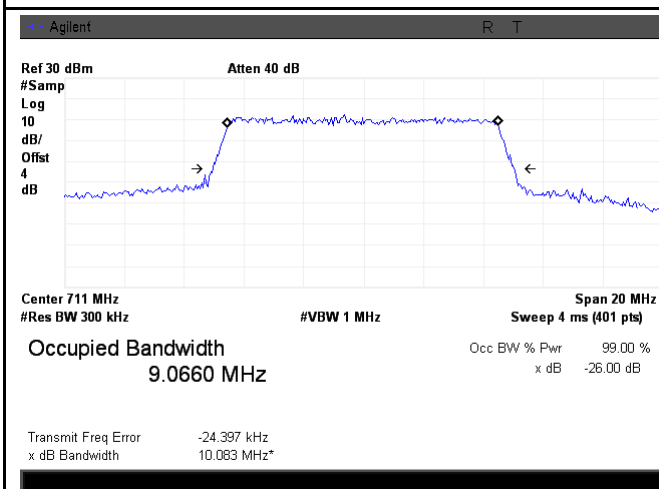

LTE band 17 - High CH QPSK-10

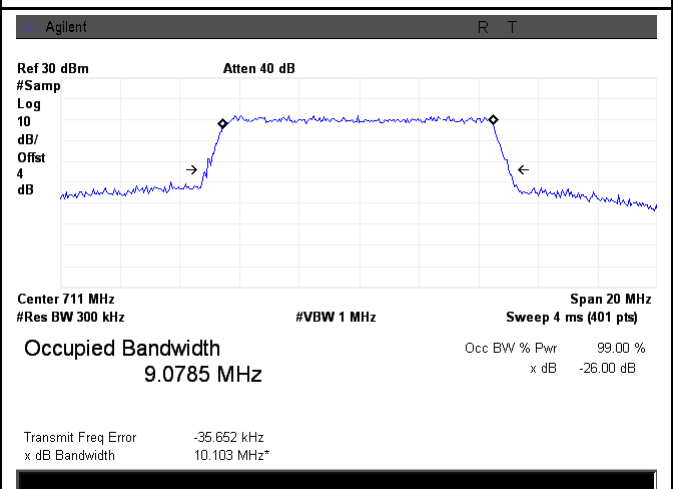

LTE band 17 - High CH 16QAM-10

6.6 Spurious Emissions at Antenna Terminals

Temperature	22°C
Relative Humidity	57%
Atmospheric Pressure	1005mbar
Test date :	November 05, 2015
Tested By :	Winnie Zhang

Requirement(s):

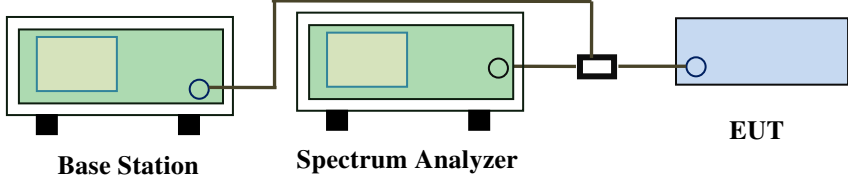
Spec	Item	Requirement	Applicable
§2.1051, §22.917(a)& §24.238(a) § 27.53(h)	a)	The power of any emission outside of the authorized operating frequency ranges must be lower than the transmitter power (P) by a factor of at least $43 + 10 \log(P)$ dB	<input checked="" type="checkbox"/>
Test Setup	 <p>The diagram shows a Base Station (green box) connected to a Spectrum Analyzer (green box) and an EUT (blue box) via a power divider (black box). The Base Station and Spectrum Analyzer are connected to the power divider, which then splits the signal to the EUT.</p>		
Test Procedure	<ul style="list-style-type: none"> - The EUT was connected to Spectrum Analyzer and Base Station via power divider. - The Band Edges of low and high channels for the highest RF powers were measured. - Setting RBW as roughly BW/100. 		
Remark			
Result	<input checked="" type="checkbox"/> Pass <input type="checkbox"/> Fail		

Test Data Yes N/A
 Test Plot Yes (See below) N/A

Test Plots 30MHz-5GHz
LTE Band 2 (Part 24E)

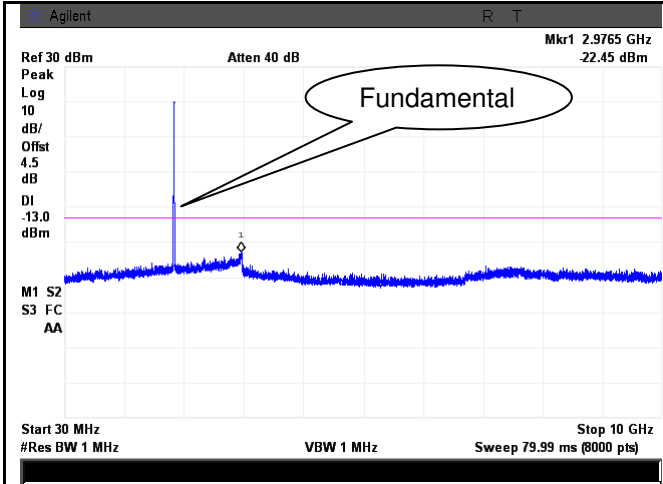

LTE Band 2 - Low Channel-1

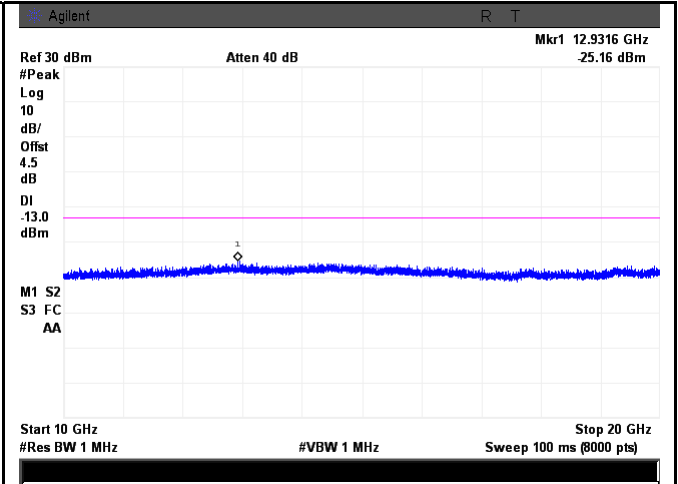

LTE Band 2 - Low Channel-2

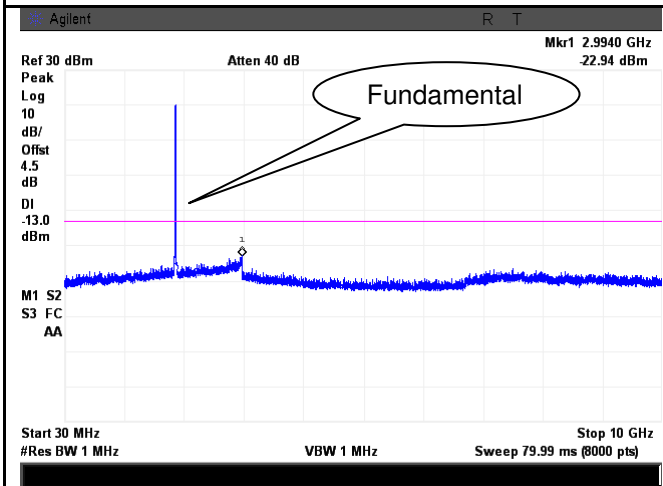

LTE Band 2 Middle Channel-1

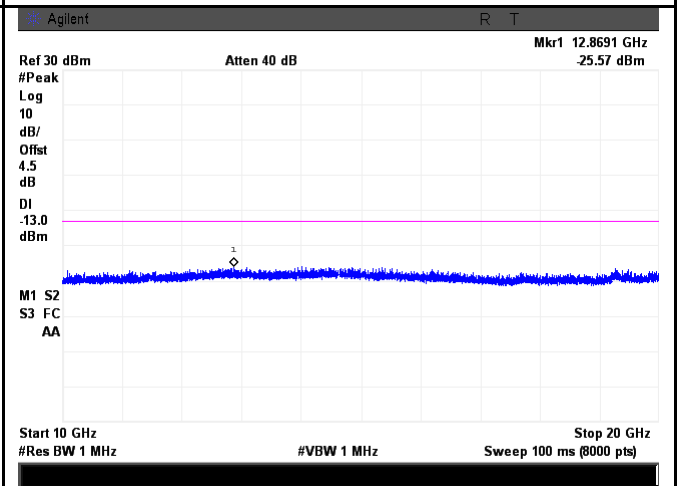

LTE Band 2 Middle Channel-2

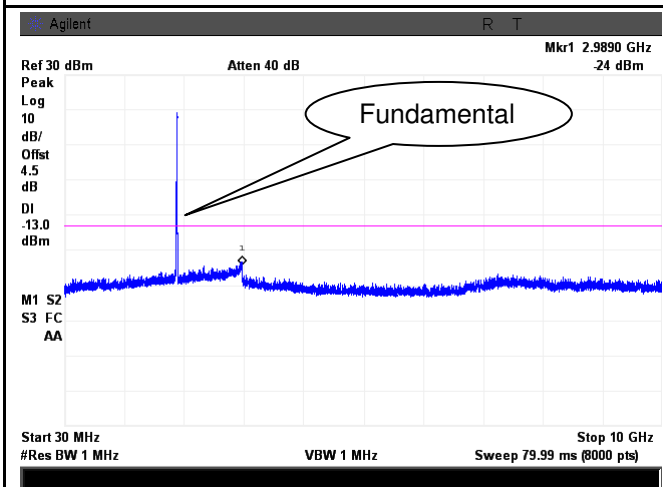

LTE Band 2 - High Channel-1

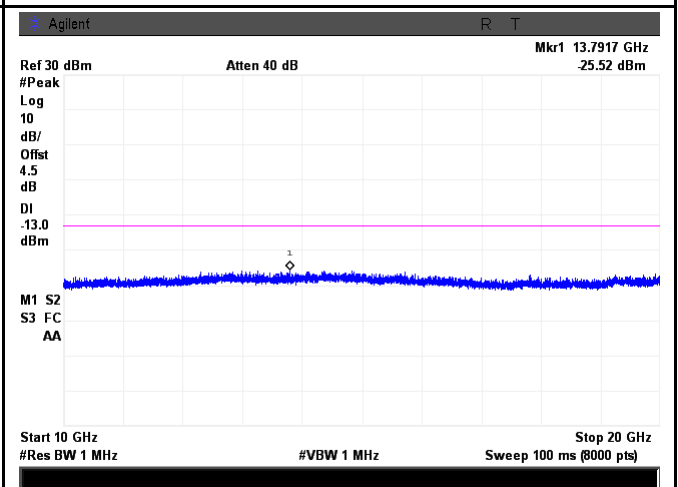

LTE Band 2 - High Channel-2

LTE Band 4 (Part27) result

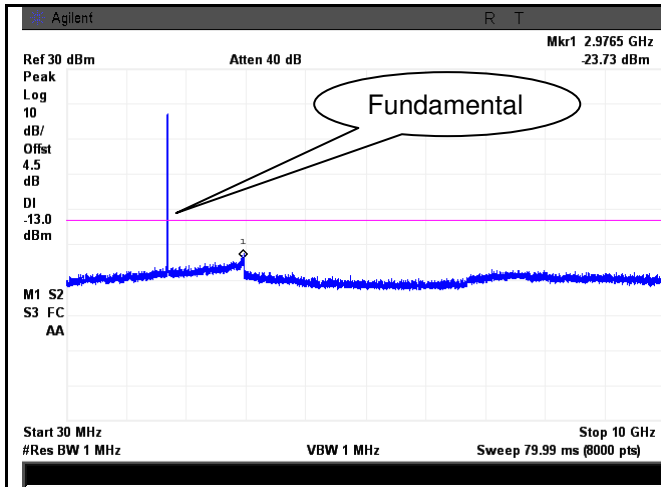

LTE Band 4 - Low Channel-1

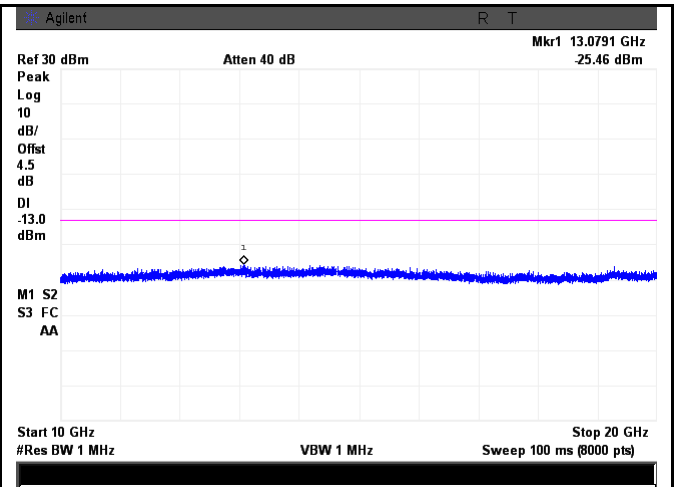

LTE Band 4 - Low Channel-2

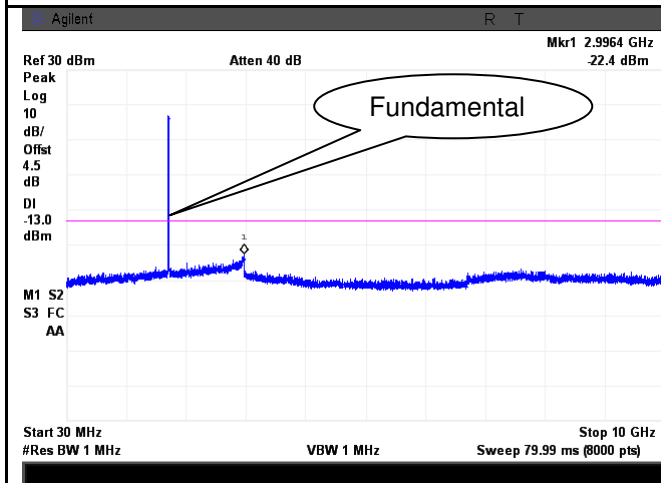

LTE Band 4 - Middle Channel-1

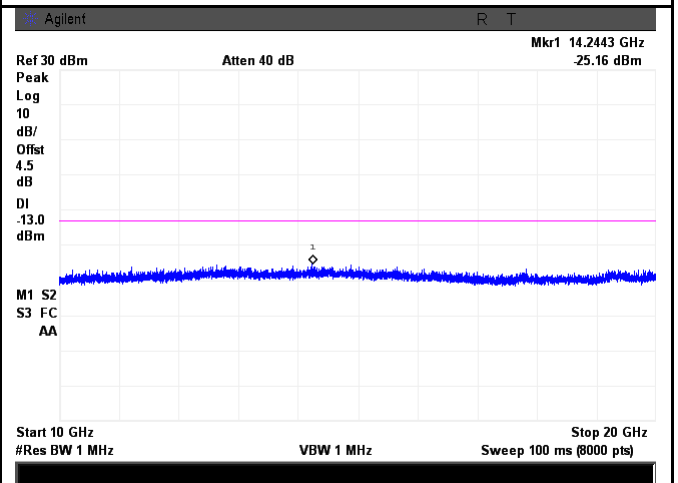

LTE Band 4 - Middle Channel-2

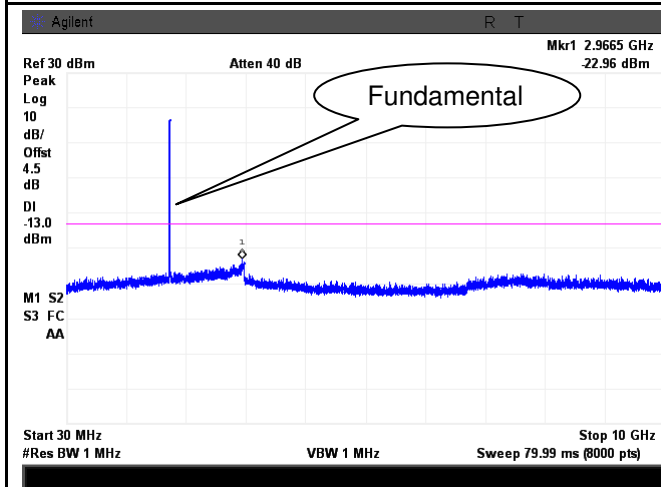

LTE Band 4 - High Channel-1

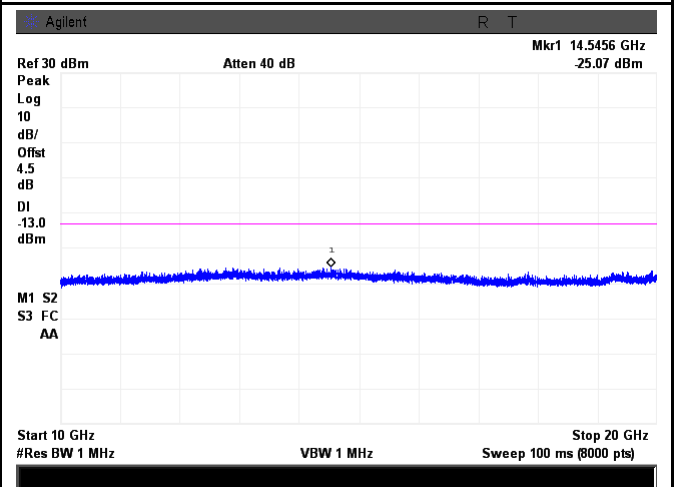

LTE Band 4 - High Channel-2

LTE Band 5 (Part 22H)

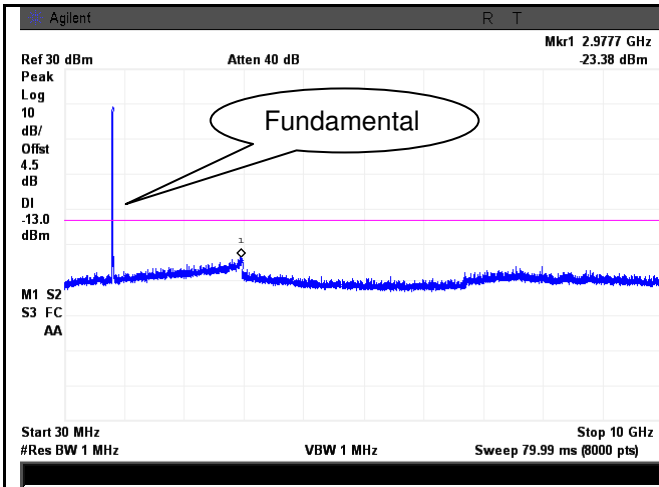

LTE Band 5 - Low Channel-1

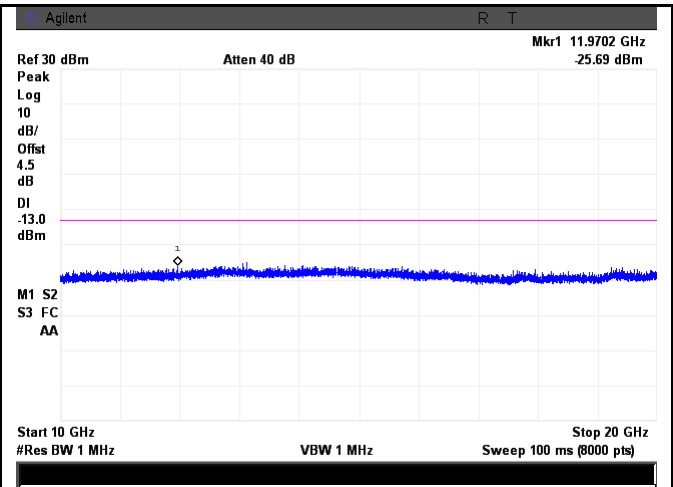

LTE Band 5 - Low Channel-2

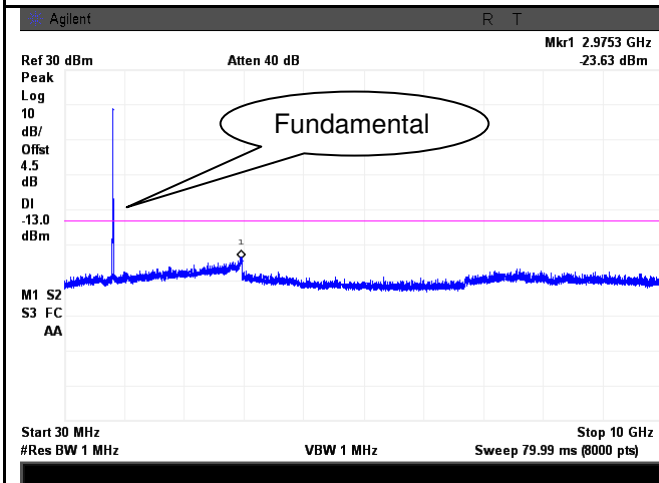

LTE Band 5 - Middle Channel-1

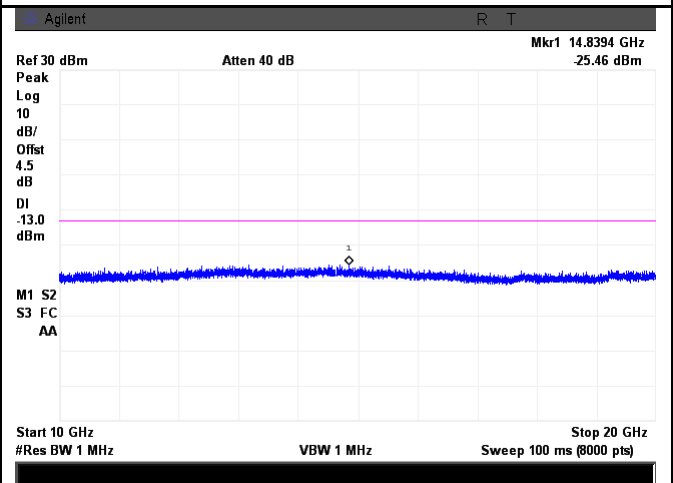

LTE Band 5 - Middle Channel-2

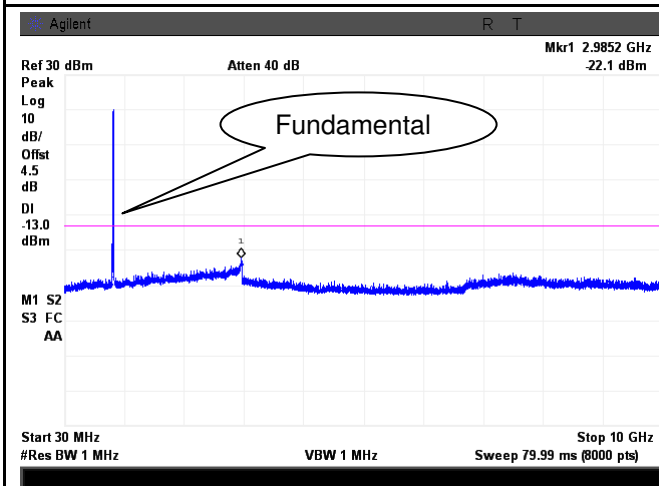

LTE Band 5 - High Channel-1

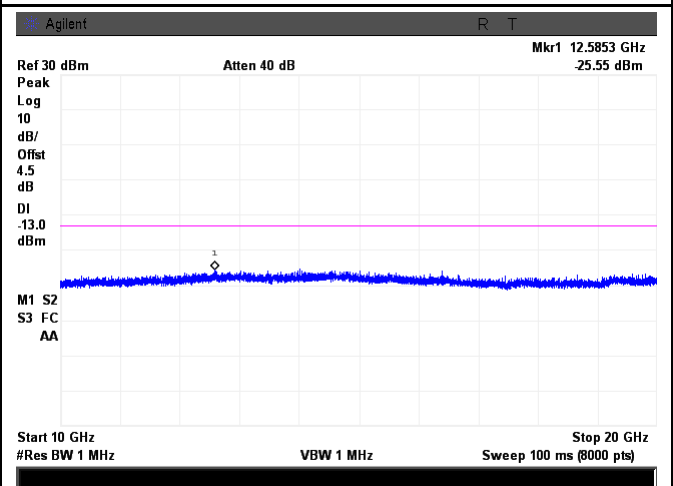

LTE Band 5 - High Channel-2

LTE Band 7 (Part 27)

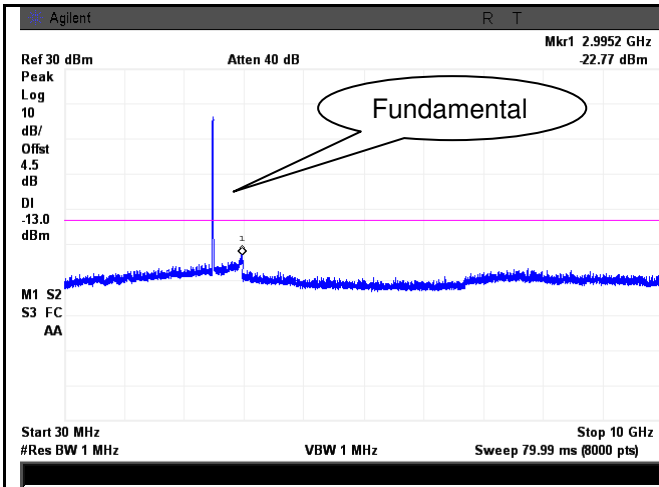

LTE Band 7 - Low Channel-1

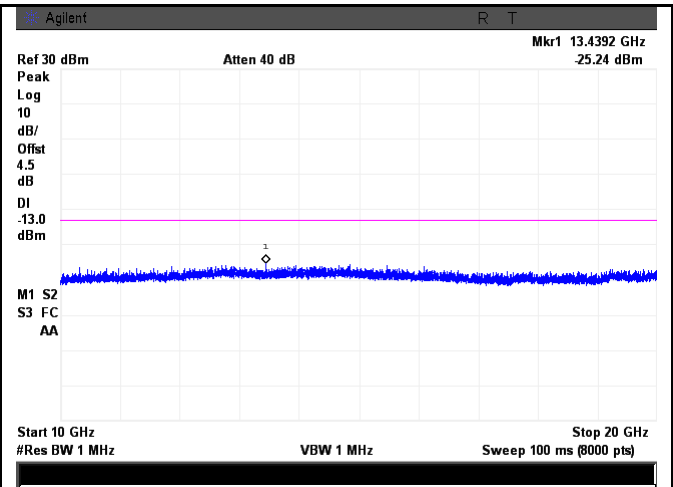

LTE Band 7 - Low Channel-2

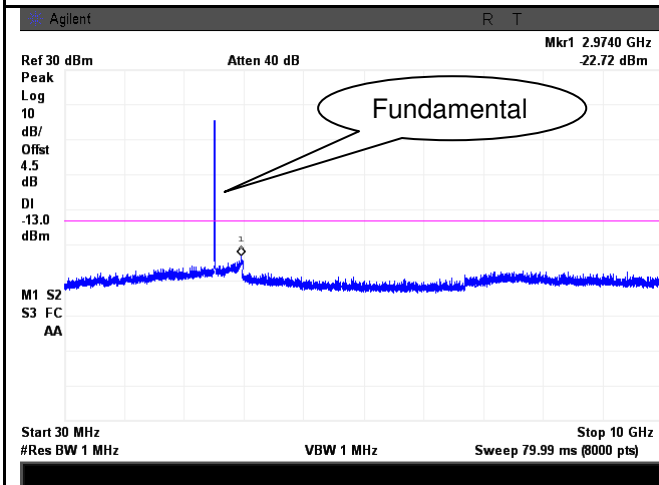

LTE Band 7 - Middle Channel-1

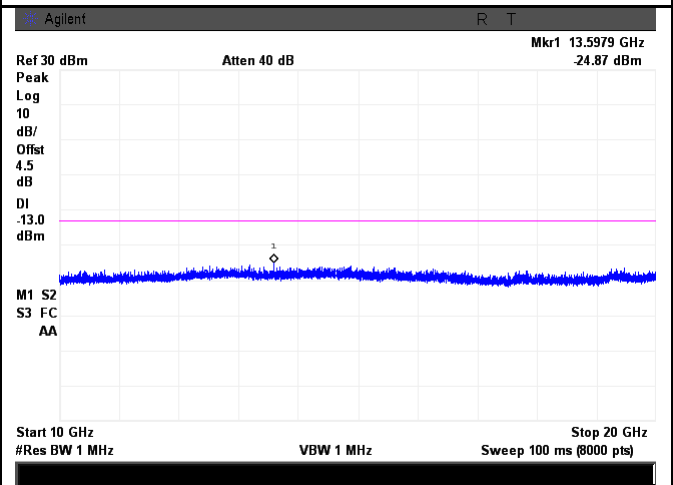

LTE Band 7 - Middle Channel-2

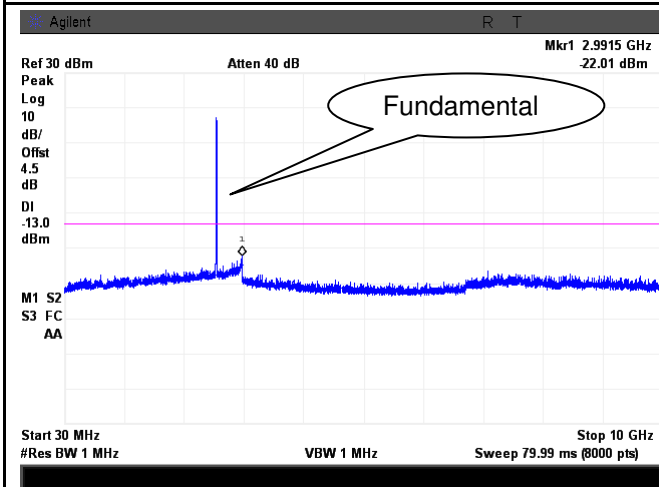

LTE Band 7 - High Channel-1

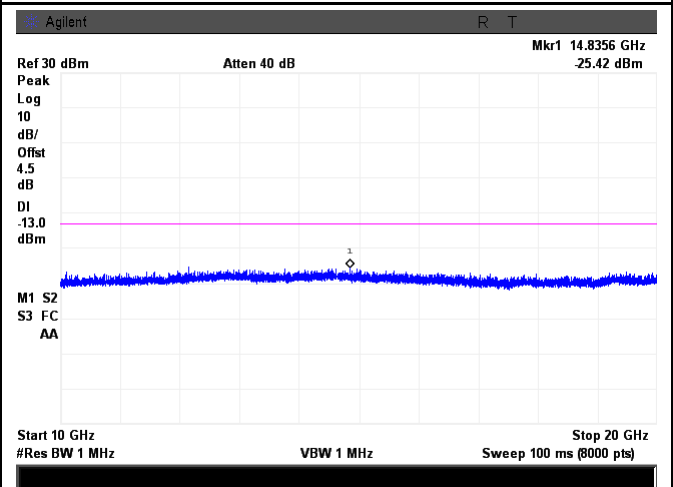

LTE Band 7 - High Channel-2

LTE Band 17 (Part 27)

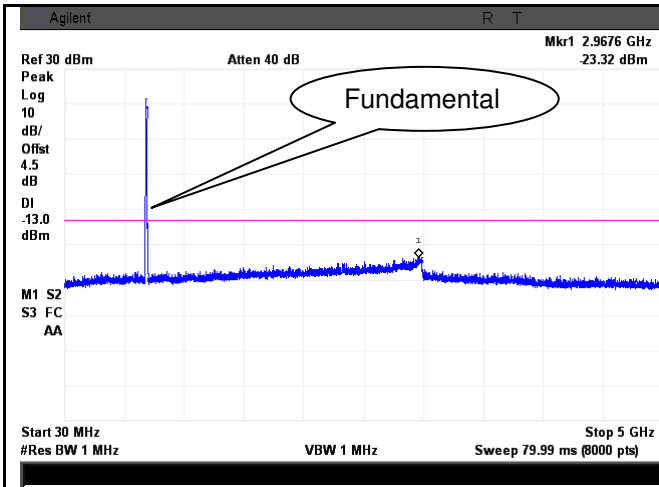

LTE Band 17 - Low Channel-1

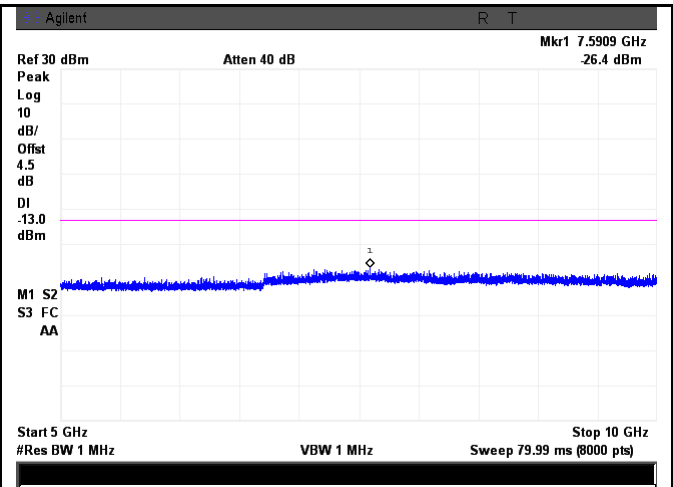

LTE Band 17 - Low Channel-2

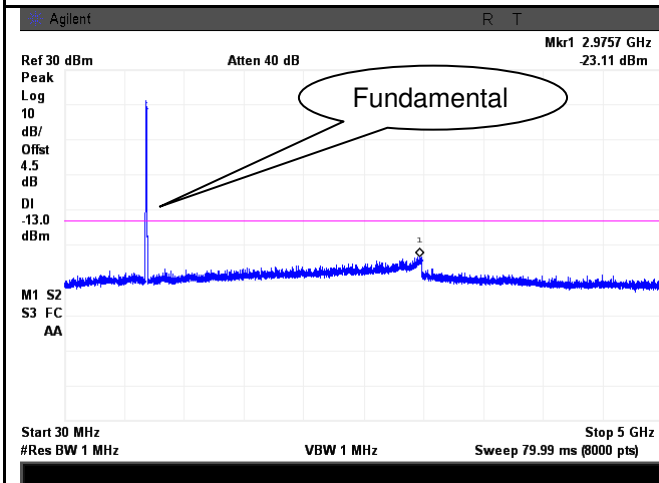

LTE Band 17 - Middle Channel-1

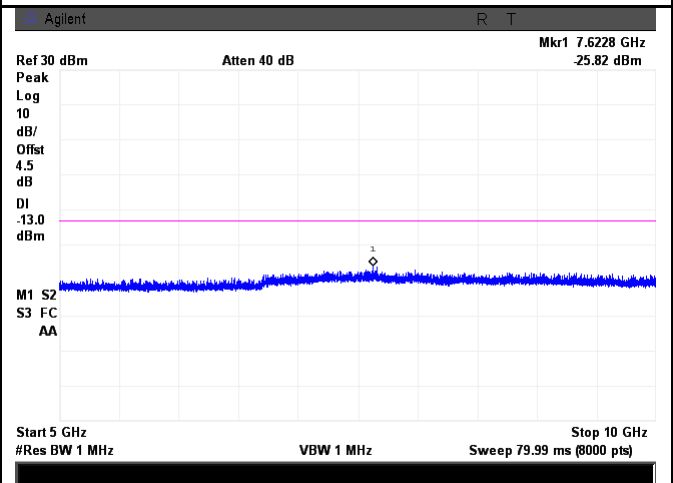

LTE Band 17 - Middle Channel-2

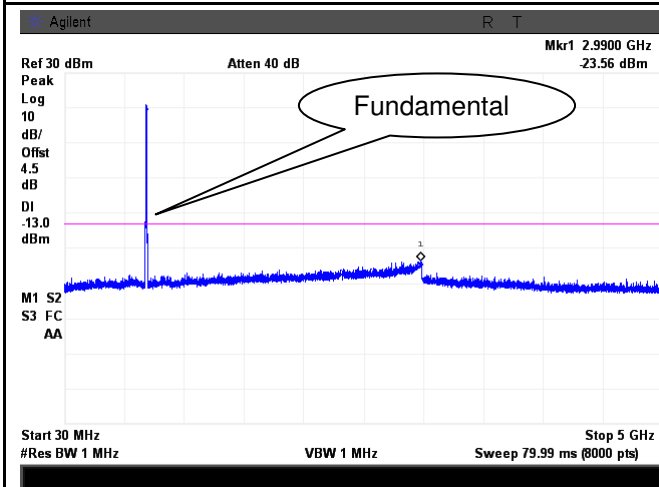

LTE Band 17 - High Channel-1

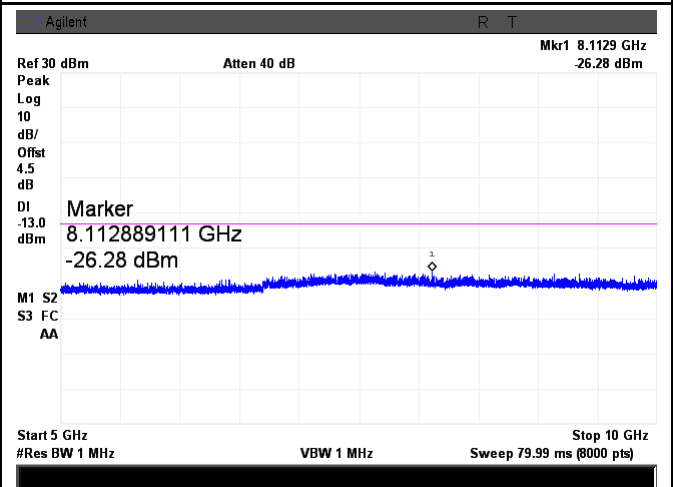

LTE Band 17 - High Channel-2

6.7 Spurious Radiated Emissions

Temperature	22°C
Relative Humidity	57%
Atmospheric Pressure	1005mbar
Test date :	November 05, 2015
Tested By :	Winnie Zhang

Requirement(s):

Spec	Item	Requirement	Applicable
§2.1053, §22.917 & §24.238 § 27.53(h)	a)	The power of any emission outside of the authorized operating frequency ranges must be attenuated below the transmitter power (P) by a factor of at least $43 + 10 \log (P)$ dB. The spectrum is scanned from 30 MHz up to a frequency including its 10th harmonic.	<input checked="" type="checkbox"/>

Test setup	
------------	--

Test Procedure	<ol style="list-style-type: none"> The transmitter was placed on a wooden turntable, and it was transmitting into a non-radiating load which was also placed on the turntable. The measurement antenna was placed at a distance of 3 meters from the EUT. During the tests, the antenna height and polarization as well as EUT azimuth were varied in order to identify the maximum level of emissions from the EUT. The test was performed by placing the EUT on 3-orthogonal axis. Remove the EUT and replace it with substitution antenna. A signal generator was connected to the substitution antenna by a non-radiating cable. The absolute levels of the spurious emissions were measured by the substitution. Sample Calculation: EUT Field Strength = Raw Amplitude (dBµV/m) – Amplifier Gain (dB) + Antenna
----------------	----------------------------------------------------------------------------------------------------------------------------------------------------------------------------------------------------------------------------------------------------------------------------------------------------------------------------------------------------------------------------------------------------------------------------------------------------------------------------------------------------------------------------------------------------------------------------------------------------------------------------------------------------------------------------------------------------------------------------------------------------------------------------------------------------------------------------------------------------------------

	Factor (dB) + Cable Loss (dB) + Filter Attenuation (dB, if used)
Remark	
Result	<input checked="" type="checkbox"/> Pass <input type="checkbox"/> Fail

Test Data Yes N/A

Test Plot Yes (See below) N/A

LTE Band 2 (Part 24E) result

Low channel

Frequency (MHz)	Substituted level (dBm)	Polarity (H/V)	Antenna Gain Correction (dB)	Cable Loss (dB)	Corrected Reading (dBm)	Limit (dBm)	Margin (dB)
3720	-44.83	V	10.25	2.73	-37.31	-13	-24.31
3720	-45.38	H	10.25	2.73	-37.86	-13	-24.86
63.5	-40.61	V	-4.2	0.11	-44.92	-13	-31.92
188.1	-49.55	H	4.6	0.18	-45.13	-13	-32.13

Middle channel

Frequency (MHz)	Substituted level (dBm)	Polarity (H/V)	Antenna Gain Correction (dB)	Cable Loss (dB)	Corrected Reading (dBm)	Limit (dBm)	Margin (dB)
3760	-44.86	V	10.25	2.73	-37.34	-13	-24.34
3760	-45.32	H	10.25	2.73	-37.80	-13	-24.80
63.3	-40.57	V	-4.2	0.11	-44.88	-13	-31.88
188.5	-49.81	H	4.6	0.18	-45.39	-13	-32.39

High channel

Frequency (MHz)	Substituted level (dBm)	Polarity (H/V)	Antenna Gain Correction (dB)	Cable Loss (dB)	Corrected Reading (dBm)	Limit (dBm)	Margin (dB)
3800	-44.81	V	10.36	2.73	-37.18	-13	-24.18
3800	-45.26	H	10.36	2.73	-37.63	-13	-24.63

Test Report	15070962-FCC-R5
Page	86 of 133

63.6	-40.63	V	-4.2	0.11	-44.94	-13	-31.94
188.4	-49.77	H	4.6	0.18	-45.35	-13	-32.35

LTE Band 4(Part27) result

Low channel

Frequency (MHz)	Substituted level (dBm)	Polarity (H/V)	Antenna Gain Correction (dB)	Cable Loss (dB)	Corrected Reading (dBm)	Limit (dBm)	Margin (dB)
3440	-46.75	V	10.06	2.52	-39.21	-13	-26.21
3440	-47.31	H	10.06	2.52	-39.77	-13	-26.77
62.8	-42.17	V	-4.2	0.11	-46.48	-13	-33.48
180.5	-51.23	H	4.6	0.18	-46.81	-13	-33.81

Middle channel

Frequency (MHz)	Substituted level (dBm)	Polarity (H/V)	Antenna Gain Correction (dB)	Cable Loss (dB)	Corrected Reading (dBm)	Limit (dBm)	Margin (dB)
3465	-46.71	V	10.09	2.52	-39.14	-13	-26.14
3465	-47.28	H	10.09	2.52	-39.71	-13	-26.71
62.9	-42.23	V	-4.2	0.11	-46.54	-13	-33.54
180.8	-51.17	H	4.6	0.18	-46.75	-13	-33.75

High channel

Frequency (MHz)	Substituted level (dBm)	Polarity (H/V)	Antenna Gain Correction (dB)	Cable Loss (dB)	Corrected Reading (dBm)	Limit (dBm)	Margin (dB)
3490	-46.68	V	10.09	2.52	-39.11	-13	-26.11
3490	-47.33	H	10.09	2.52	-39.76	-13	-26.76
62.3	-42.29	V	-4.2	0.11	-46.60	-13	-33.60
180.5	-51.22	H	4.6	0.18	-46.80	-13	-33.80

LTE Band 5(Part22H) result

Low channel

Frequency (MHz)	Substituted level (dBm)	Polarity (H/V)	Antenna Gain Correction (dB)	Cable Loss (dB)	Corrected Reading (dBm)	Limit (dBm)	Margin (dB)
1658	-44.26	V	7.95	0.78	-37.09	-13	-24.09
1658	-44.95	H	7.95	0.78	-37.78	-13	-24.78
64.1	-39.51	V	-4.2	0.11	-43.82	-13	-30.82
182.3	-48.76	H	4.6	0.18	-44.34	-13	-31.34

Middle channel

Frequency (MHz)	Substituted level (dBm)	Polarity (H/V)	Antenna Gain Correction (dB)	Cable Loss (dB)	Corrected Reading (dBm)	Limit (dBm)	Margin (dB)
1673	-44.21	V	7.95	0.78	-37.04	-13	-24.04
1673	-44.89	H	7.95	0.78	-37.72	-13	-24.72
64.5	-39.53	V	-4.2	0.11	-43.84	-13	-30.84
182.2	-48.81	H	4.6	0.18	-44.39	-13	-31.39

High channel

Frequency (MHz)	Substituted level (dBm)	Polarity (H/V)	Antenna Gain Correction (dB)	Cable Loss (dB)	Corrected Reading (dBm)	Limit (dBm)	Margin (dB)
1688	-44.25	V	7.95	0.78	-37.08	-13	-24.08
1688	-44.93	H	7.95	0.78	-37.76	-13	-24.76
64.8	-39.47	V	-4.2	0.11	-43.78	-13	-30.78
182.5	-48.86	H	4.6	0.18	-44.44	-13	-31.44

LTE Band 7(Part27) result

Low channel

Frequency (MHz)	Substituted level (dBm)	Polarity (H/V)	Antenna Gain Correction (dB)	Cable Loss (dB)	Corrected Reading (dBm)	Limit (dBm)	Margin (dB)
5020	-49.51	V	10.29	0.98	-40.20	-13	-27.20
5020	-50.27	H	10.29	0.98	-40.96	-13	-27.96
63.2	-41.63	V	-4.2	0.11	-45.94	-13	-32.94
181.9	-50.86	H	4.6	0.18	-46.44	-13	-33.44

Middle channel

Frequency (MHz)	Substituted level (dBm)	Polarity (H/V)	Antenna Gain Correction (dB)	Cable Loss (dB)	Corrected Reading (dBm)	Limit (dBm)	Margin (dB)
5070	-49.47	V	10.3	0.99	-40.16	-13	-27.16
5070	-50.15	H	10.3	0.99	-40.84	-13	-27.84
63.4	-41.53	V	-4.2	0.11	-45.84	-13	-32.84
181.5	-50.89	H	4.6	0.18	-46.47	-13	-33.47

High channel

Frequency (MHz)	Substituted level (dBm)	Polarity (H/V)	Antenna Gain Correction (dB)	Cable Loss (dB)	Corrected Reading (dBm)	Limit (dBm)	Margin (dB)
5120	-49.44	V	10.32	1	-40.12	-13	-27.12
5120	-50.09	H	10.32	1	-40.77	-13	-27.77
63.7	-41.45	V	-4.2	0.11	-45.76	-13	-32.76
181.6	-50.82	H	4.6	0.18	-46.40	-13	-33.40

LTE Band 17(Part27) result

Low channel

Frequency (MHz)	Substituted level (dBm)	Polarity (H/V)	Antenna Gain Correction (dB)	Cable Loss (dB)	Corrected Reading (dBm)	Limit (dBm)	Margin (dB)
1418	-44.83	V	7.65	0.75	-37.93	-13	-24.93
1418	-45.37	H	7.65	0.75	-38.47	-13	-25.47
65.2	-40.51	V	-4.2	0.11	-44.82	-13	-31.82
183.7	-49.79	H	4.6	0.18	-45.37	-13	-32.37

Middle channel

Frequency (MHz)	Substituted level (dBm)	Polarity (H/V)	Antenna Gain Correction (dB)	Cable Loss (dB)	Corrected Reading (dBm)	Limit (dBm)	Margin (dB)
1420	-44.79	V	7.65	0.75	-37.89	-13	-24.89
1420	-45.32	H	7.65	0.75	-38.42	-13	-25.42
65.5	-40.46	V	-4.2	0.11	-44.77	-13	-31.77
183.1	-49.71	H	4.6	0.18	-45.29	-13	-32.29

High channel

Frequency (MHz)	Substituted level (dBm)	Polarity (H/V)	Antenna Gain Correction (dB)	Cable Loss (dB)	Corrected Reading (dBm)	Limit (dBm)	Margin (dB)
1422	-44.83	V	7.65	0.75	-37.93	-13	-24.93
1422	-45.26	H	7.65	0.75	-38.36	-13	-25.36
65.9	-40.38	V	-4.2	0.11	-44.69	-13	-31.69
183.5	-49.65	H	4.6	0.18	-45.23	-13	-32.23

6.8 Band Edge

Temperature	22°C
Relative Humidity	57%
Atmospheric Pressure	1005mbar
Test date :	November 05, 2015
Tested By :	Winnie Zhang

Requirement(s):

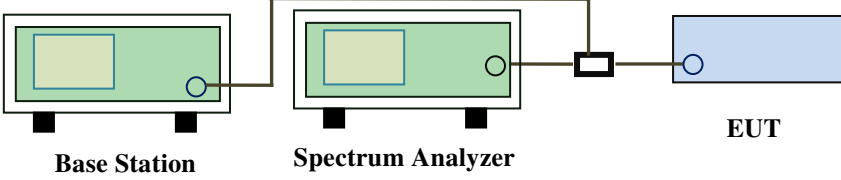
Spec	Item	Requirement	Applicable
§22.917(a) §24.238(a) § 27.53(h)	a)	The power of any emission outside of the authorized operating frequency ranges must be lower than the transmitter power (P) by a factor of at least $43 + 10 \log (P)$ dB.	<input checked="" type="checkbox"/>
Test setup	 <p>The diagram shows a Base Station (green box) connected to a Spectrum Analyzer (green box) and an EUT (blue box) via a power divider (black box). The Base Station and Spectrum Analyzer are connected to the power divider, which then splits the signal to the EUT.</p>		
Procedure	<ul style="list-style-type: none"> - The EUT was connected to Spectrum Analyzer and Base Station via power divider. - The Band Edges of low and high channels for the highest RF powers were measured. Setting RBW as roughly BW/100. 		
Remark			
Result	<input checked="" type="checkbox"/> Pass <input type="checkbox"/> Fail		

Test Data Yes N/A

Test Plot Yes (See below) N/A

LTE Band 2 (Part 24E) result

BW(MHz)	Channel	Frequency (MHz)	Mode	Emission (dBm)	Limit (dBm)
1.4	18607	1850.7	QPSK	-20.60	-13
			16QAM	-20.50	-13
1.4	18900	1909.3	QPSK	-21.11	-13
			16QAM	-20.95	-13
3	18615	1851.5	QPSK	-23.06	-13
			16QAM	-23.10	-13
3	19185	1908.5	QPSK	-22.44	-13
			16QAM	-22.97	-13
5	18625	1852.5	QPSK	-14.40	-13
			16QAM	-19.44	-13
5	19175	1907.5	QPSK	-19.80	-13
			16QAM	-19.53	-13
10	18650	1855	QPSK	-20.07	-13
			16QAM	-20.69	-13
10	19150	1905	QPSK	-22.71	-13
			16QAM	-20.02	-13
15	18675	1857.5	QPSK	-17.36	-13
			16QAM	-17.61	-13
15	19125	1902.5	QPSK	-20.13	-13
			16QAM	-20.12	-13
20	18700	1860	QPSK	-19.28	-13
			16QAM	-19.08	-13
20	19100	1900	QPSK	-19.75	-13
			16QAM	-19.47	-13

LTE Band 4 (Part 27) result

BW(MHz)	Channel	Frequency (MHz)	Mode	Emission (dBm)	Limit (dBm)
1.4	19957	1710.7	QPSK	-18.61	-13
			16QAM	-18.10	-13
1.4	20393	1754.3	QPSK	-23.03	-13
			16QAM	-23.95	-13
3	19965	1711.5	QPSK	-15.51	-13
			16QAM	-16.11	-13
3	20385	1753.5	QPSK	-17.14	-13
			16QAM	-18.50	-13
5	19975	1712.5	QPSK	-22.69	-13
			16QAM	-19.44	-13
5	20375	1752.5	QPSK	-22.07	-13
			16QAM	-21.16	-13
10	20000	1715	QPSK	-21.87	-13
			16QAM	-20.50	-13
10	20350	1750	QPSK	-22.63	-13
			16QAM	-21.89	-13
15	20025	1717.5	QPSK	-23.25	-13
			16QAM	-24.50	-13
15	20325	1747.5	QPSK	-23.85	-13
			16QAM	-24.18	-13
20	20050	1720	QPSK	-25.63	-13
			16QAM	-25.78	-13
20	20300	1745	QPSK	-22.72	-13
			16QAM	-22.97	-13

LTE Band 5 (Part 22H) result

BW(MHz)	Channel	Frequency (MHz)	Mode	Emission (dBm)	Limit (dBm)
1.4	20407	824.7	QPSK	-21.51	-13
			16QAM	-21.21	-13
1.4	20643	848.3	QPSK	-15.57	-13
			16QAM	-15.56	-13
3	20415	825.5	QPSK	-19.36	-13
			16QAM	-19.83	-13
3	20635	847.5	QPSK	-20.33	-13
			16QAM	-20.38	-13
5	20425	826.5	QPSK	-22.05	-13
			16QAM	-22.37	-13
5	20625	846.5	QPSK	-20.94	-13
			16QAM	-21.38	-13
10	20450	829	QPSK	-19.99	-13
			16QAM	-19.84	-13
10	20800	844	QPSK	-21.66	-13
			16QAM	-21.37	-13

LTE Band 17 (Part 27) result

BW(MHz)	Channel	Frequency (MHz)	Mode	Emission (dBm)	Limit (dBm)
5	23755	706.5	QPSK	-19.50	-13
			16QAM	-18.81	-13
5	23825	713.5	QPSK	-21.53	-13
			16QAM	-22.17	-13
10	23780	709	QPSK	-22.42	-13
			16QAM	-19.11	-13
10	23800	711	QPSK	-23.54	-13
			16QAM	-22.62	-13

Test Plots

LTE Band 2 (Part 24E)

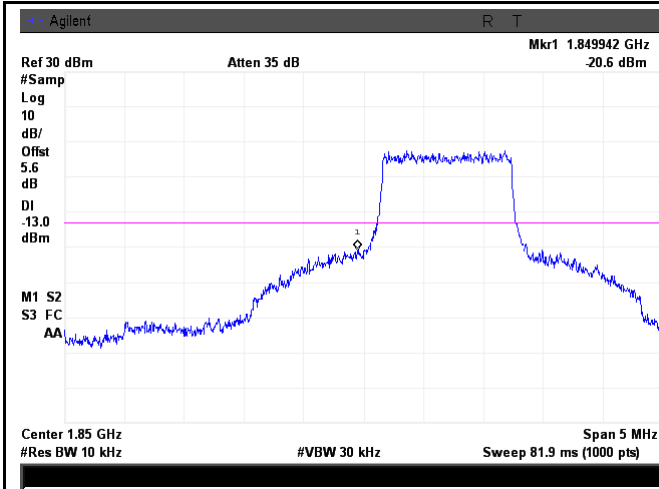

LTE Band 2 - Low Channel QPSK-1.4

Note: Offset=Cable loss (4.5) + 10log
(12.85/10)=4.5+1.1=5.6 dB

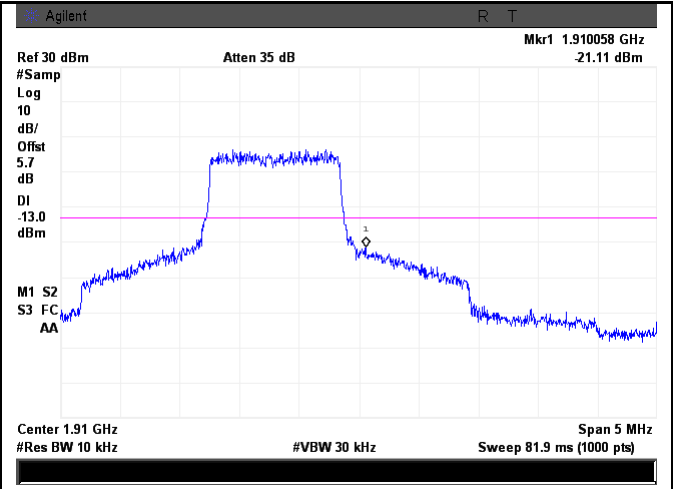

LTE Band 2 - High Channel QPSK-1.4

Note: Offset=Cable loss (4.5) + 10log
(13.09/10)=4.5+1.2=5.7 dB

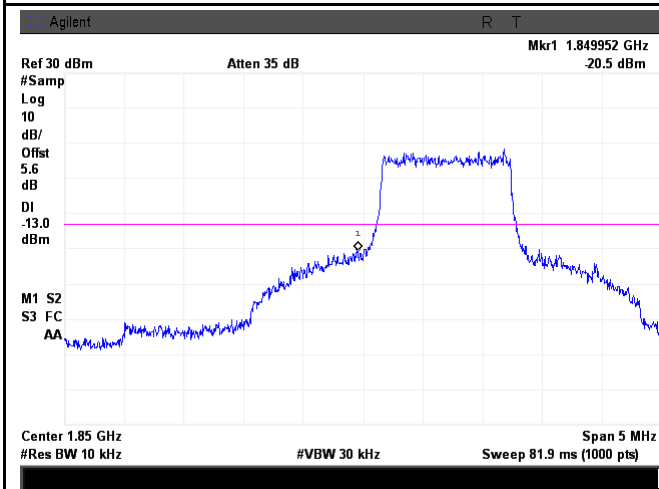

LTE Band 2 - Low Channel 16QAM-1.4

Note: Offset=Cable loss (4.5) + 10log
(12.81/10)=4.5+1.1=5.6 dB

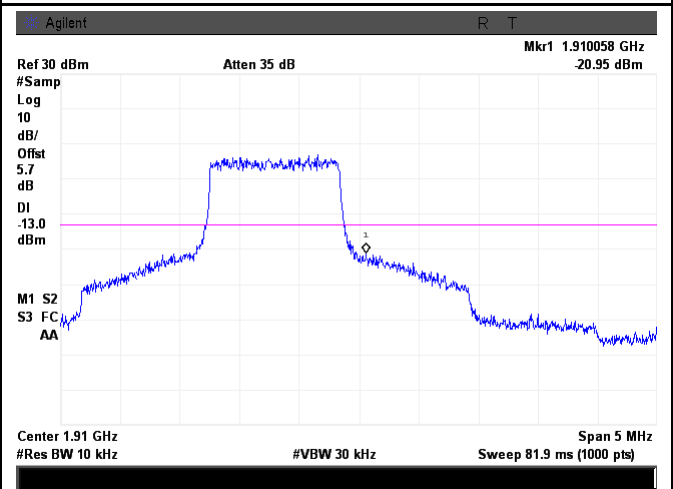

LTE Band 2 - High Channel 16QAM-1.4

Note: Offset=Cable loss (4.5) + 10log
(13.26/10)=4.5+1.2=5.7 dB

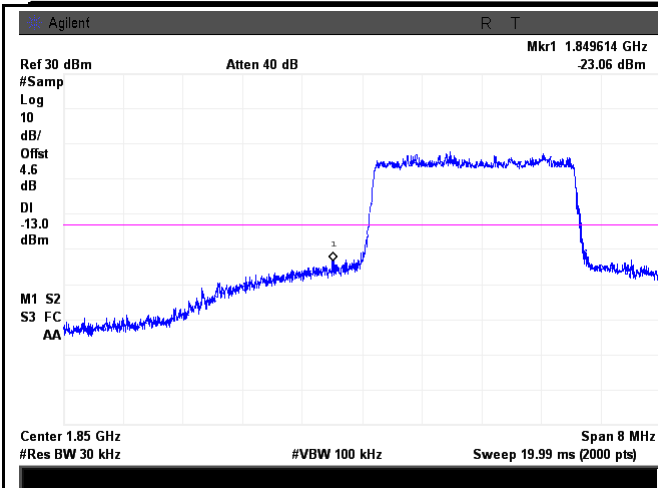

LTE Band 2 - Low Channel QPSK-3

Note: Offset=Cable loss (4.5) + 10log
(31/30)=4.5+0.1=4.6 dB

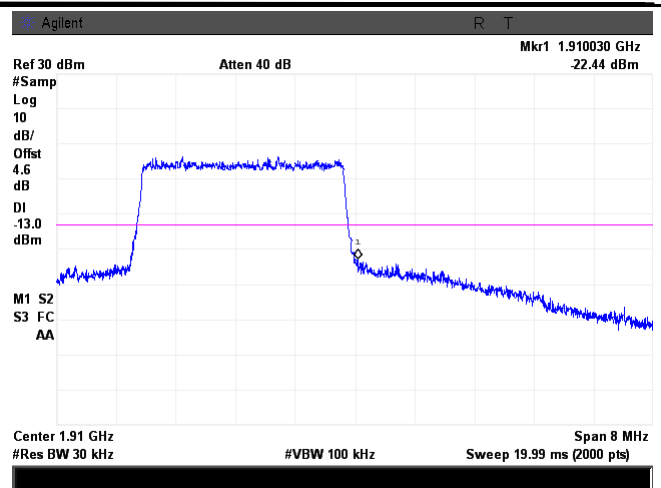

LTE Band 2 - High Channel QPSK-3

Note: Offset=Cable loss (4.5) + 10log
(30.54/30)=4.5+0.1=4.6 dB

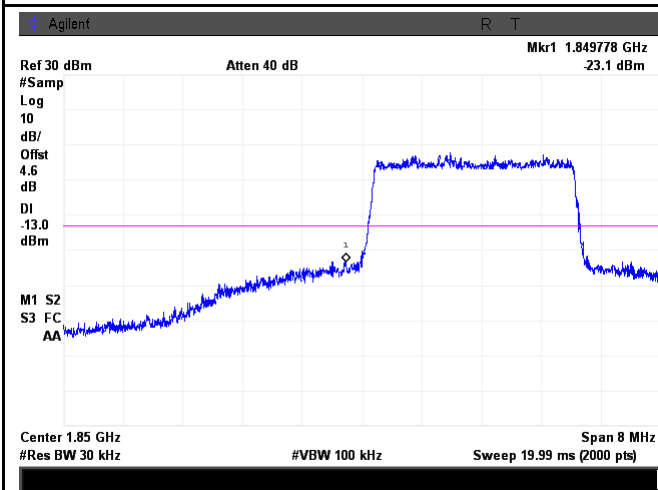

LTE Band 2 - Low Channel 16QAM-3

Note: Offset=Cable loss (4.5) + 10log
(30.95/30)=4.5+0.1=4.6 dB

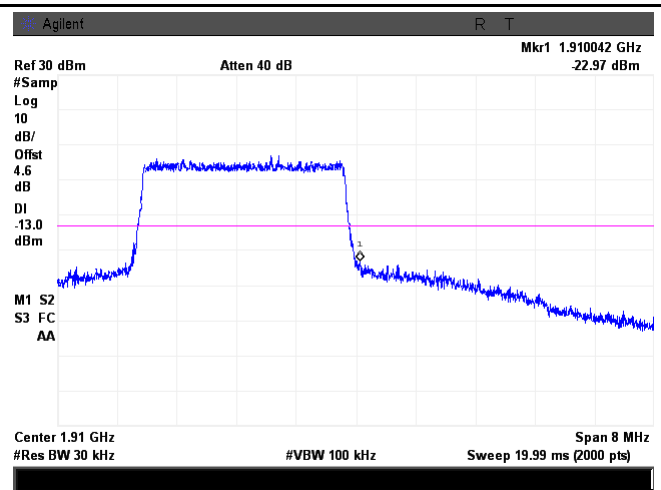

LTE Band 2 - High Channel 16QAM-3

Note: Offset=Cable loss (4.5) + 10log
(30.57/30)=4.5+0.1=4.6 dB

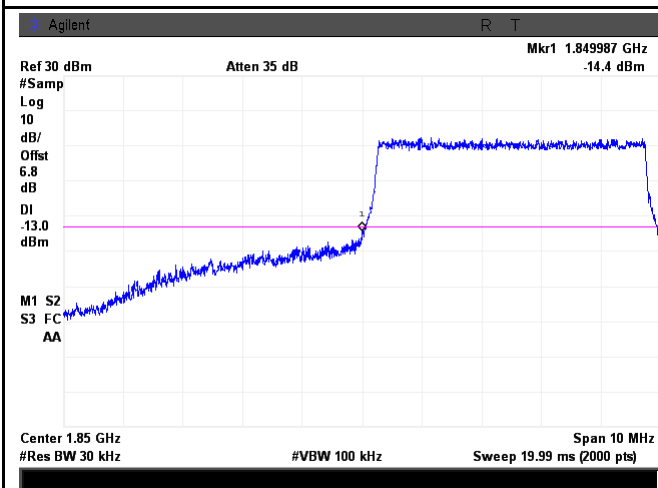

LTE Band 2 - Low Channel QPSK-5

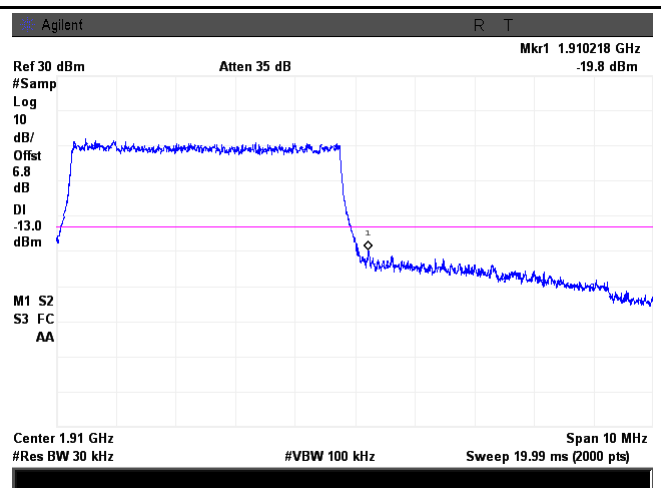

LTE Band 2 - High Channel QPSK-5

Note: Offset=Cable loss (4.5) + 10log
(50.99/30)=4.5+2.3=6.8 dB

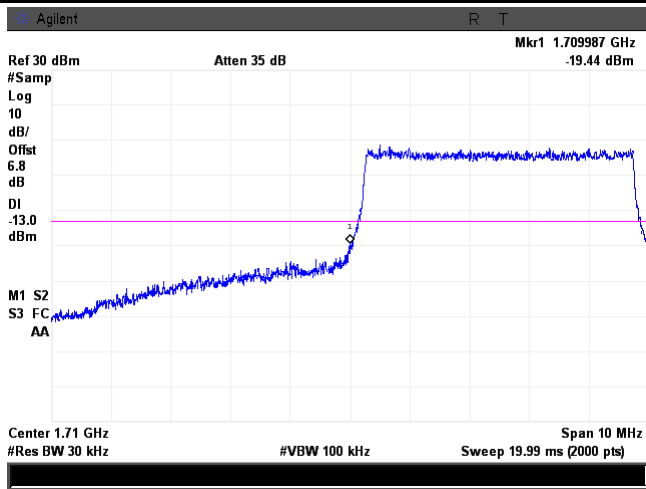

LTE Band 2 - Low Channel 16QAM-5

Note: Offset=Cable loss (4.5) + 10log
(50.53/30)=4.5+2.3=6.8 dB

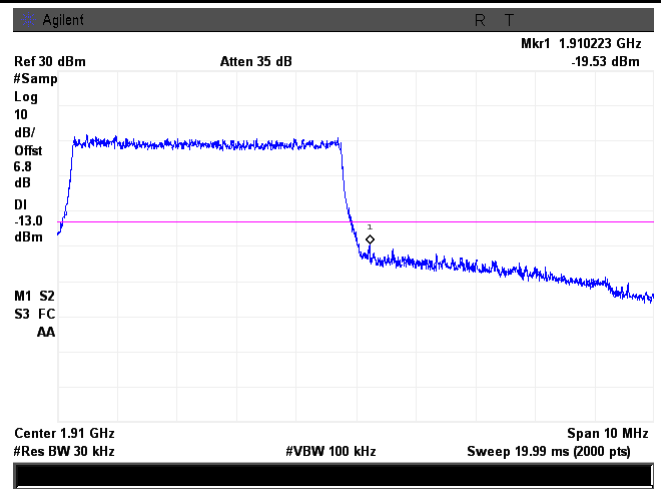

LTE Band 2 - High Channel 16QAM-5

Note: Offset=Cable loss (4.5) + 10log
(50.16/30)=4.5+2.3=6.8 dB

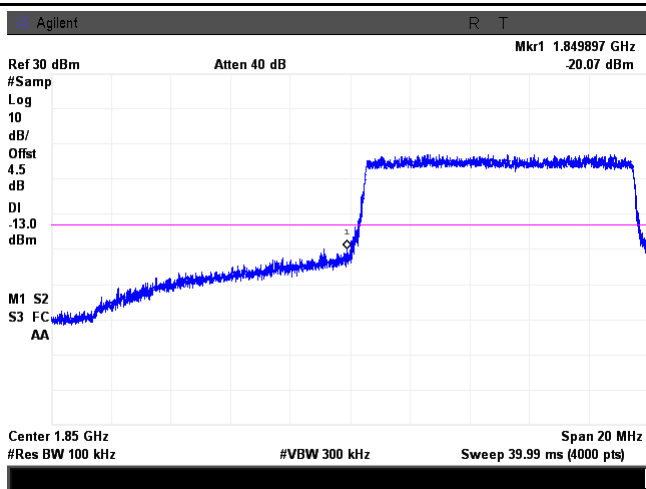

LTE Band 2 - Low Channel QPSK-10

Note: Offset=Cable loss (4.5) + 10log
(50.52/30)=4.5+2.3=6.8 dB

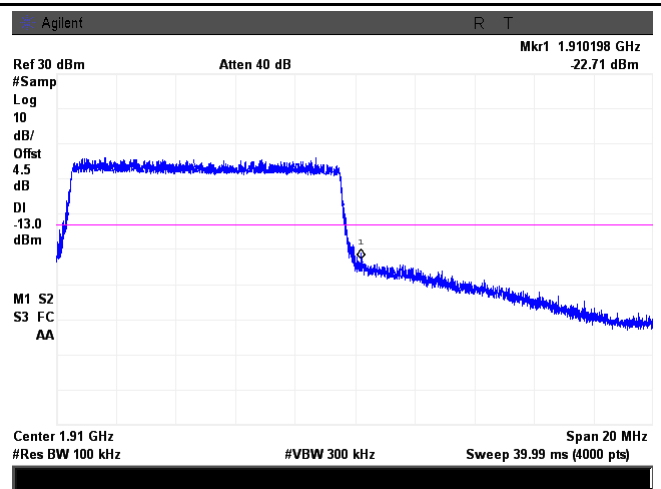

LTE Band 2 - High Channel QPSK-10

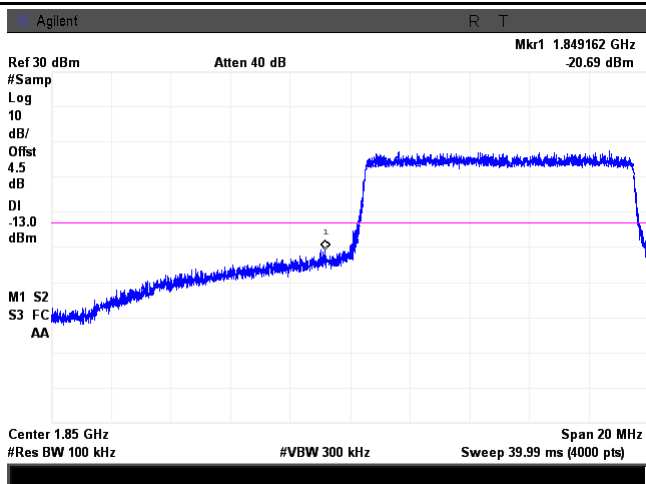

LTE Band 2 - Low Channel 16QAM-10

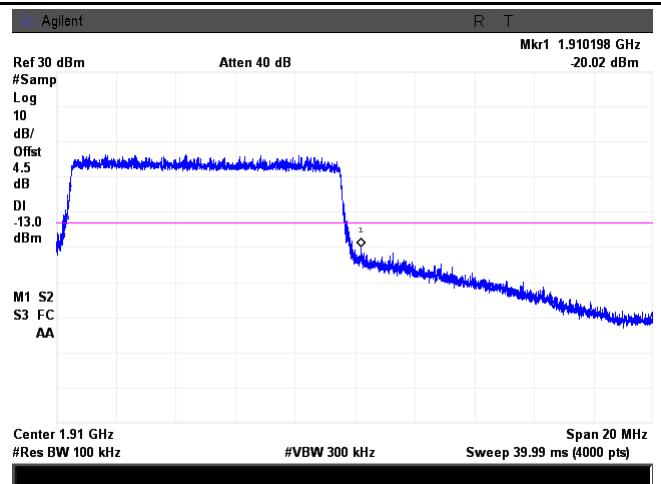

LTE Band 2 - High Channel 16QAM-10

Note: Offset=Cable loss (4.5) + 10log
(110.6/100)=4.5+0.0=4.5 dB

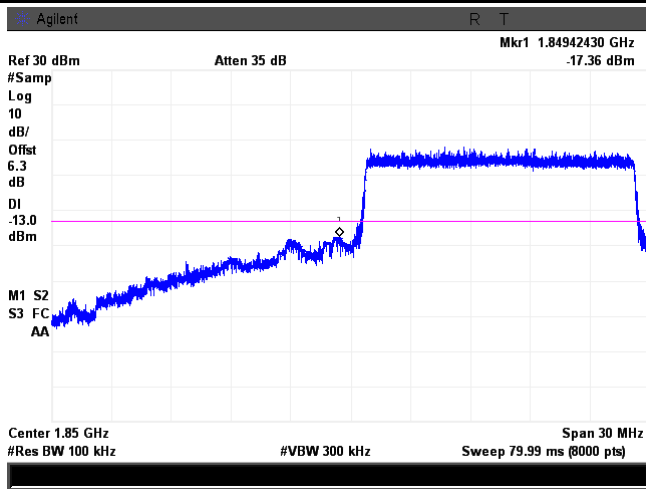

LTE Band 2 - Low Channel QPSK-15

Note: Offset=Cable loss (4.5) + 10log
(102.0/100)=4.5+0.0=4.5 dB

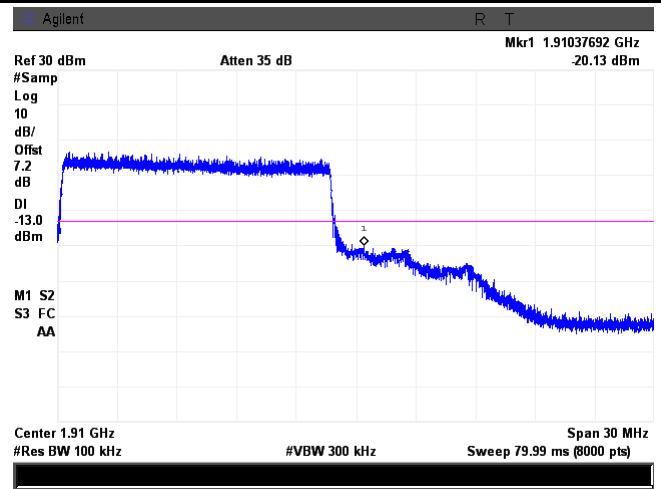

LTE Band 2 - High Channel QPSK-15

Note: Offset=Cable loss (4.5) + 10log
(151.6/100)=4.5+1.8=6.3 dB

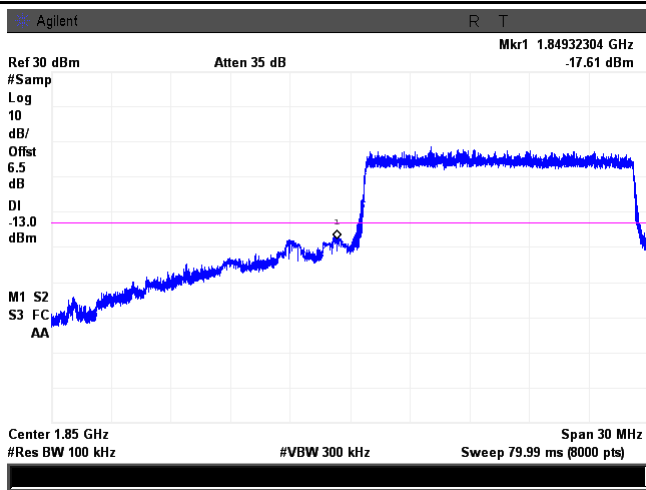

LTE Band 2 - Low Channel 16QAM-15

Note: Offset=Cable loss (4.5) + 10log
(185.2/100)=4.5+2.7=7.2 dB

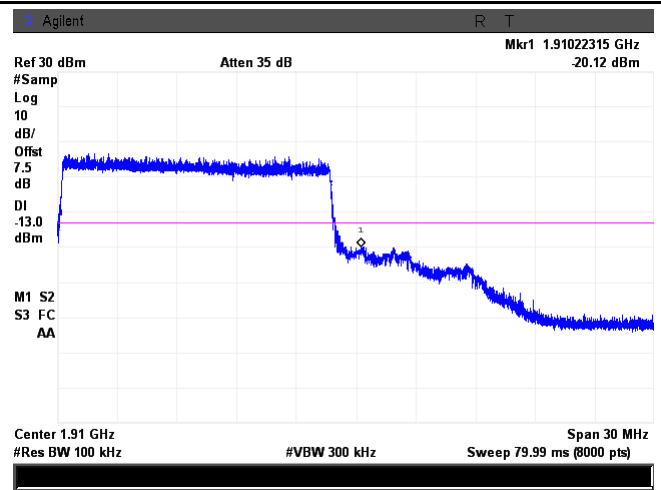

LTE Band 2 - High Channel 16QAM-15

Note: Offset=Cable loss (4.5) + 10log
(157.4/100)=4.5+2.0=6.5 dB

Note: Offset=Cable loss (4.5) + 10log
(199.6/100)=4.5+3.0=7.5 dB

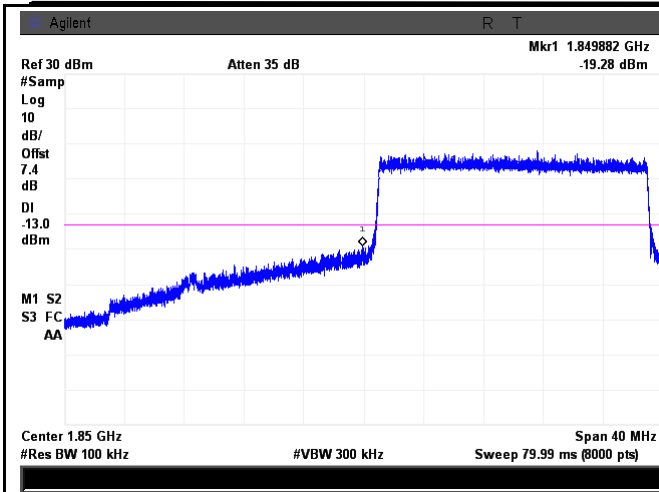

LTE Band 2 - Low Channel QPSK-20

Note: Offset=Cable loss (4.5) + 10log
(193.5/100)=4.5+2.9=7.4 dB

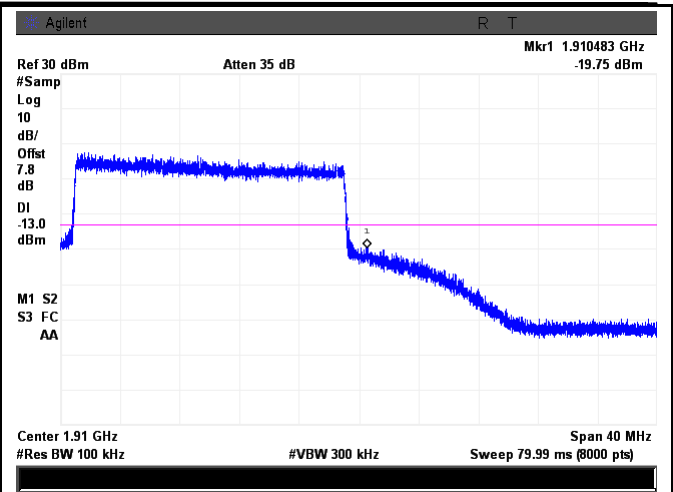

LTE Band 2 - High Channel QPSK-20

Note: Offset=Cable loss (4.5) + 10log
(213.5/100)=4.5+3.3=7.8 dB

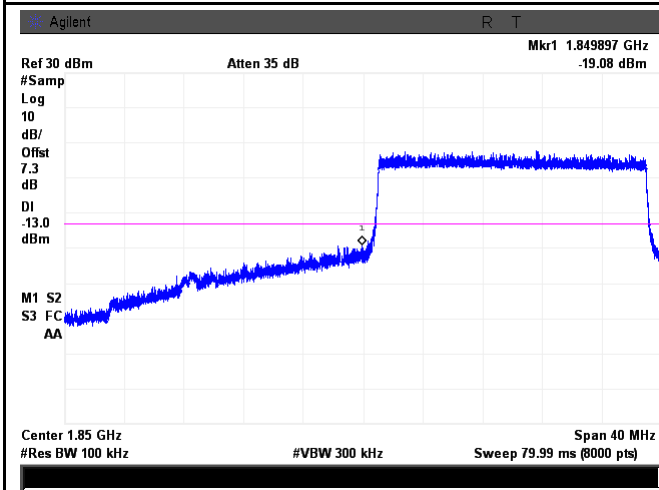

LTE Band 2 - Low Channel 16QAM-20

Note: Offset=Cable loss (4.5) + 10log
(192.6/100)=4.5+2.8=7.3 dB

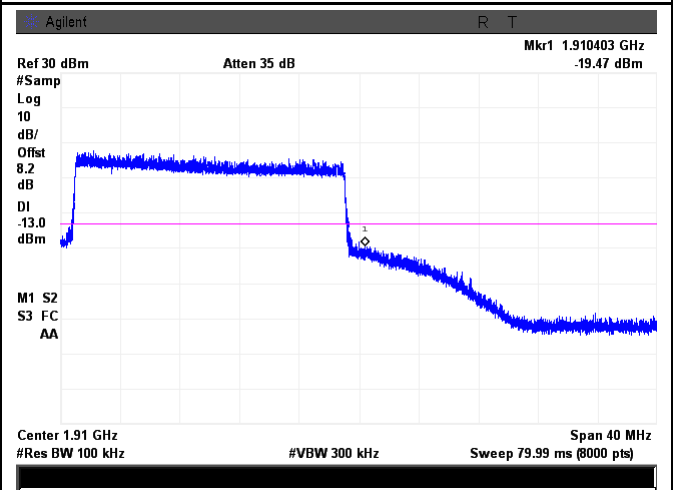

LTE Band 2 - High Channel 16QAM-20

Note: Offset=Cable loss (4.5) + 10log
(236.8/100)=4.5+3.7=8.2 dB

LTE Band 4 (Part 27)

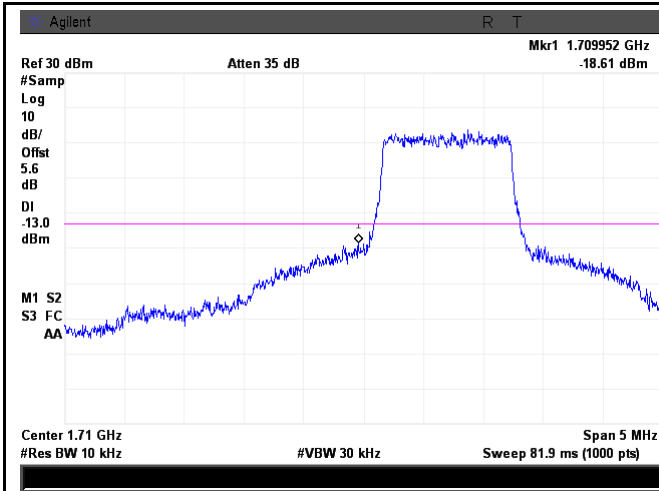

LTE Band 4 - Low Channel QPSK-1.4

Note: Offset=Cable loss (4.5) + 10log
(12.79/10)=4.5+1.1=5.6 dB

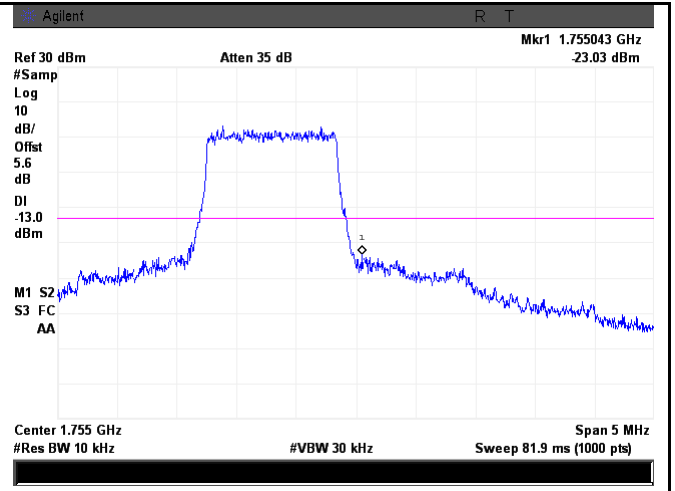

LTE Band 4 - High Channel QPSK-1.4

Note: Offset=Cable loss (4.5) + 10log
(12.83/10)=4.5+1.1=5.6 dB

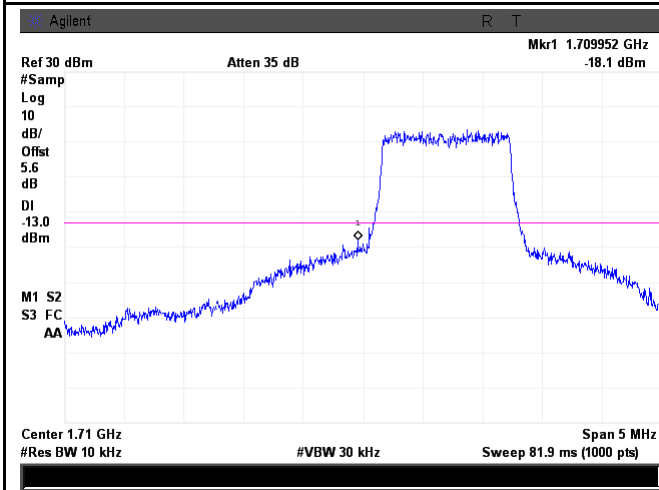

LTE Band 4 - Low Channel 16QAM-1.4

Note: Offset=Cable loss (4.5) + 10log
(12.74/10)=4.5+1.1=5.6 dB

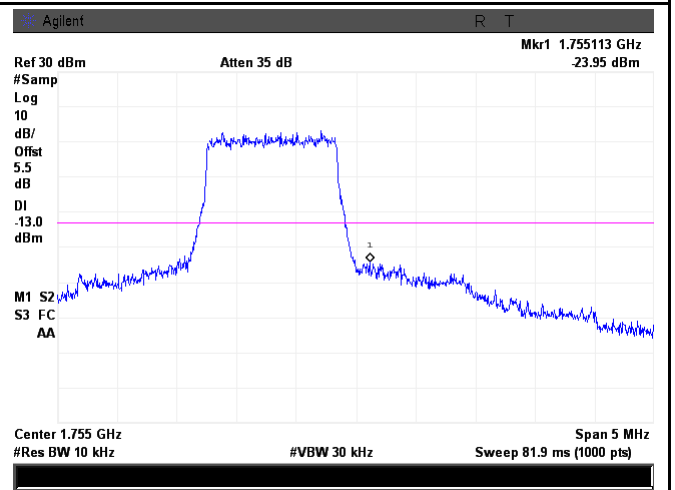

LTE Band 4 - High Channel 16QAM-1.4

Note: Offset=Cable loss (4.5) + 10log
(12.72/10)=4.5+1.0=5.5 dB

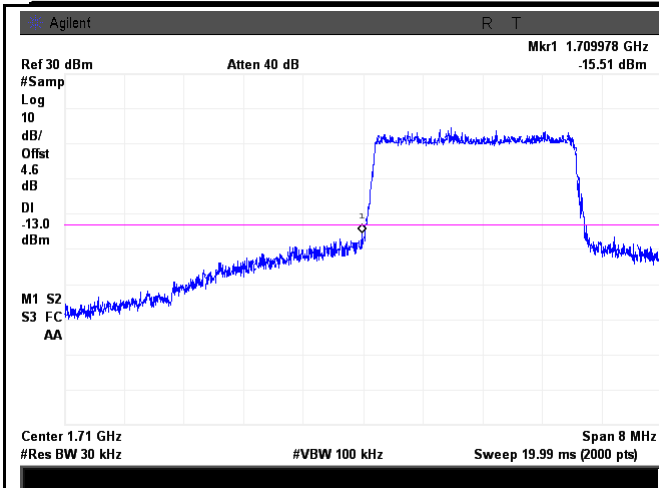

LTE Band 4 - Low Channel QPSK-3

Note: Offset=Cable loss (4.5) + 10log
(31.02/30)=4.5+0.1=4.6 dB

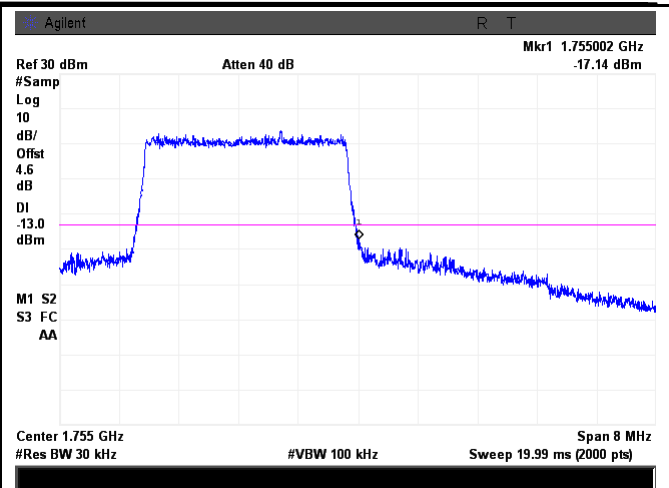

LTE Band 4 - High Channel QPSK-3

Note: Offset=Cable loss (4.5) + 10log
(30.61/30)=4.5+0.1=4.6 dB

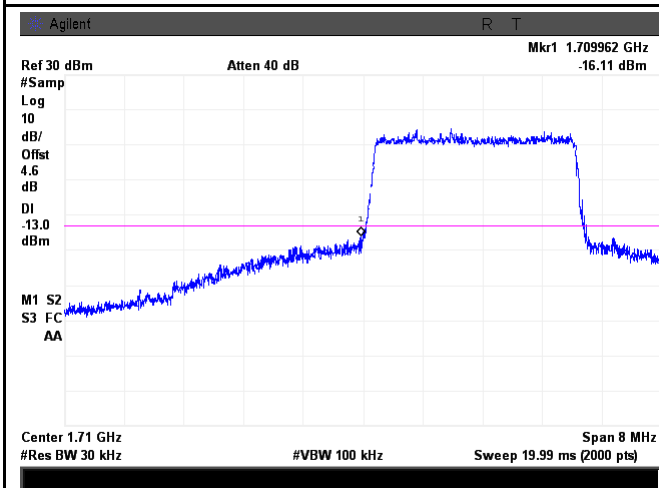

LTE Band 4 - Low Channel 16QAM-3

Note: Offset=Cable loss (4.5) + 10log
(30.63/30)=4.5+0.1=4.6 dB

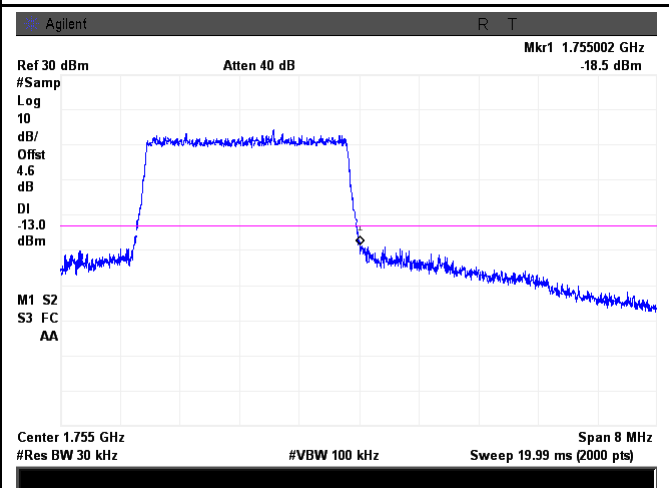

LTE Band 4 - High Channel 16QAM-3

Note: Offset=Cable loss (4.5) + 10log
(30.59/30)=4.5+0.1=4.6 dB

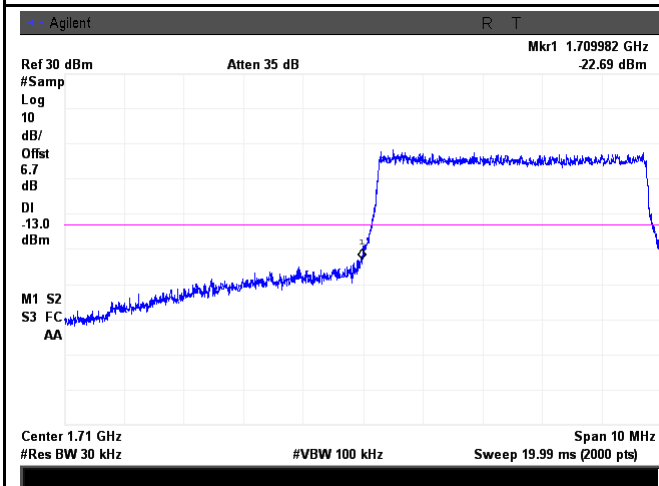

LTE Band 4 - Low Channel QPSK-5

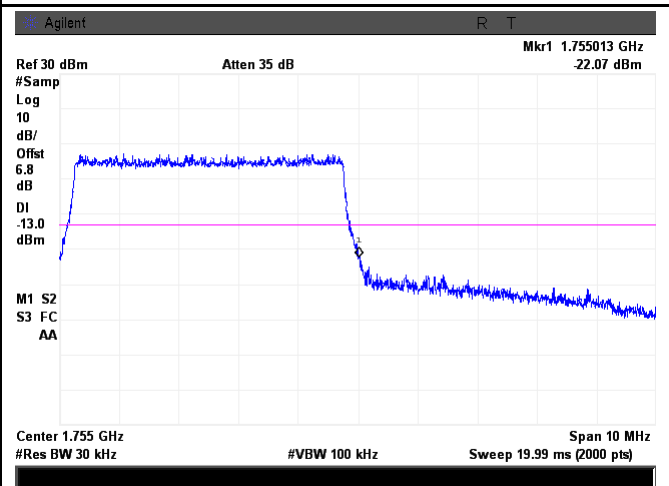

LTE Band 4 - High Channel QPSK-5

Note: Offset=Cable loss (4.5) + 10log
(50.36/30)=4.5+2.2=6.7 dB

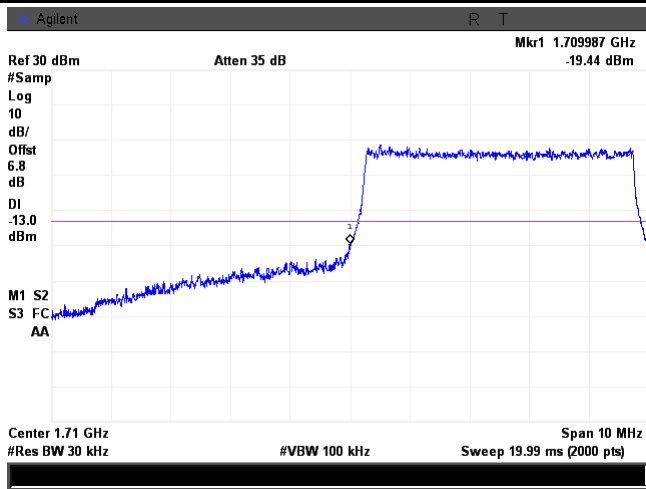

LTE Band 4 - Low Channel 16QAM-5

Note: Offset=Cable loss (4.5) + 10log
(50.38/30)=4.5+2.3=6.8 dB

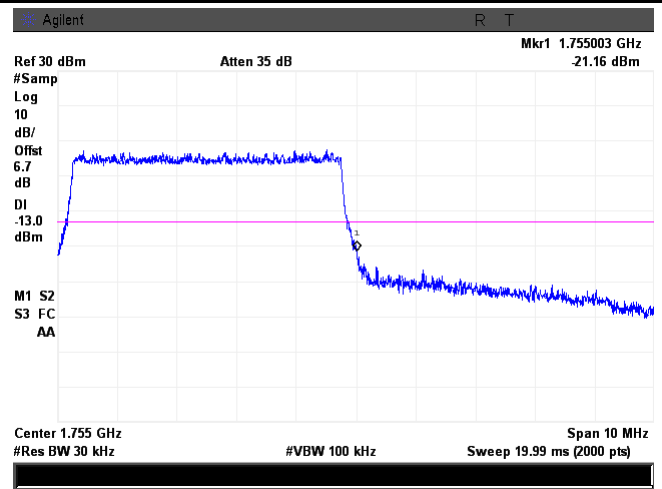

LTE Band 4 - High Channel 16QAM-5

Note: Offset=Cable loss (4.5) + 10log
(51/30)=4.5+2.3=6.8 dB

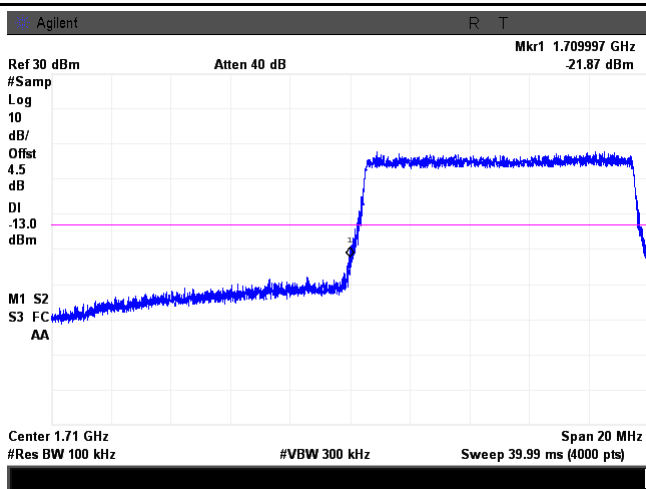

LTE Band 4 - Low Channel QPSK-10

Note: Offset=Cable loss (4.5) + 10log
(49.41/30)=4.5+2.2=6.7 dB

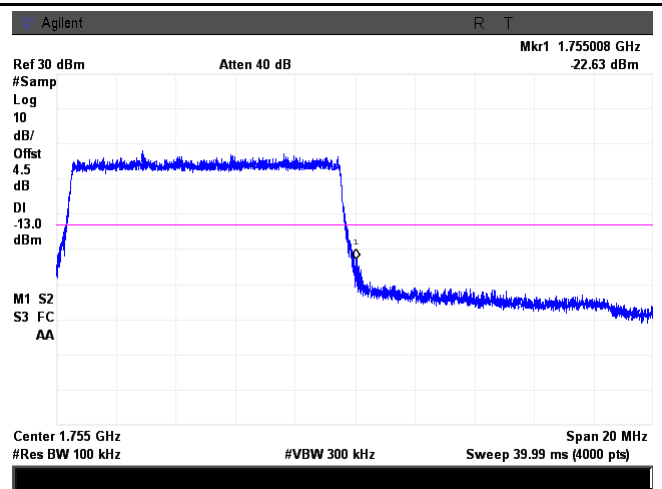

LTE Band 4 - High Channel QPSK-10

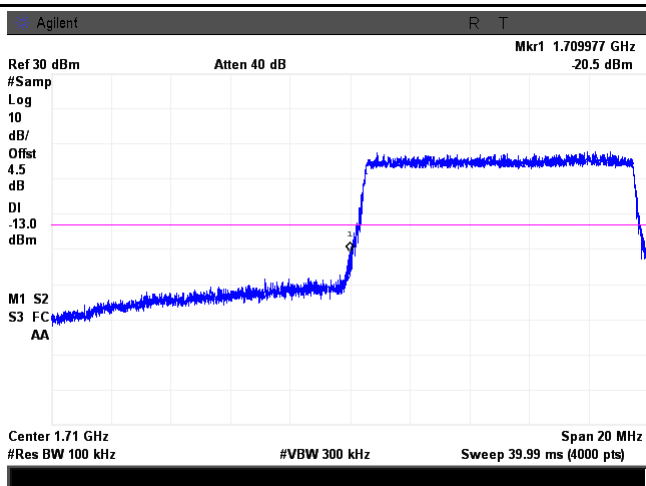

LTE Band 4 - Low Channel 16QAM-10

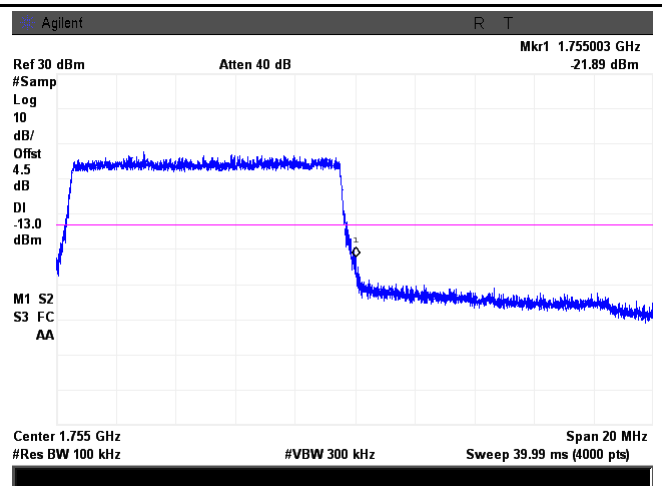

LTE Band 4 - High Channel 16QAM-10

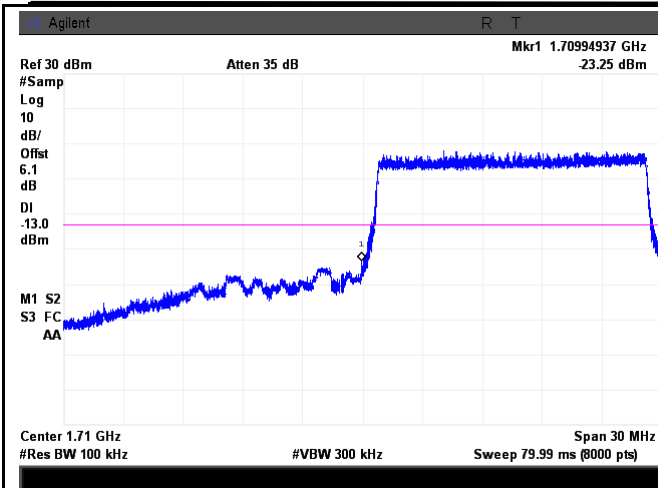

LTE Band 4 - Low Channel QPSK-15

Note: Offset=Cable loss (4.5) + 10log
(145.6/100)=4.5+1.6=6.1 dB

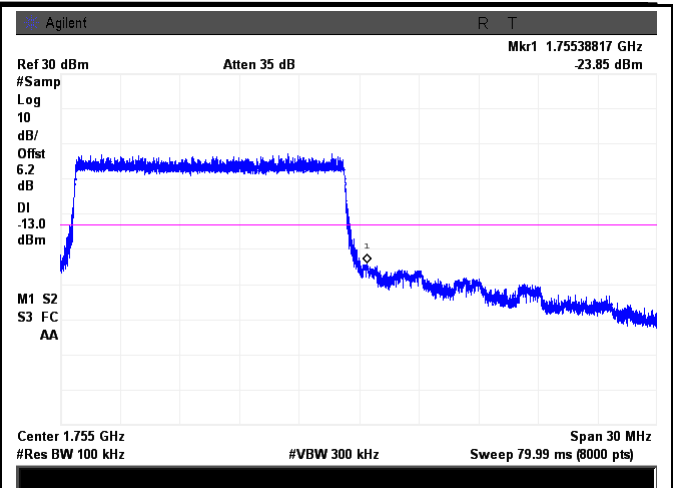

LTE Band 4 - High Channel QPSK-15

Note: Offset=Cable loss (4.5) + 10log
(148.6/100)=4.5+1.7=6.2 dB

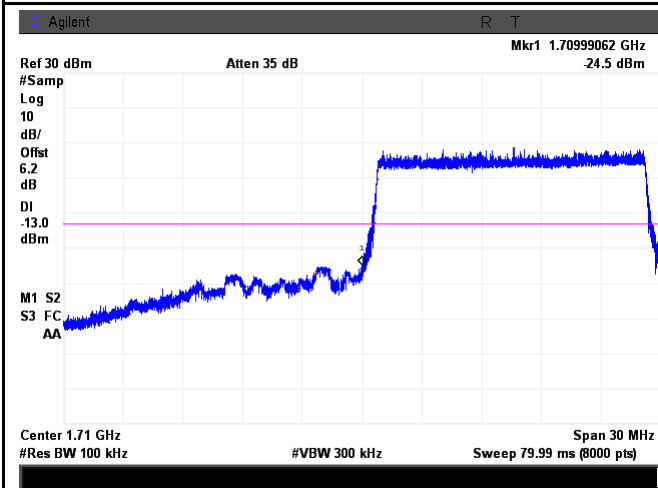

LTE Band 4 - Low Channel 16QAM-15

Note: Offset=Cable loss (4.5) + 10log
(148.6/100)=4.5+1.7=6.2 dB

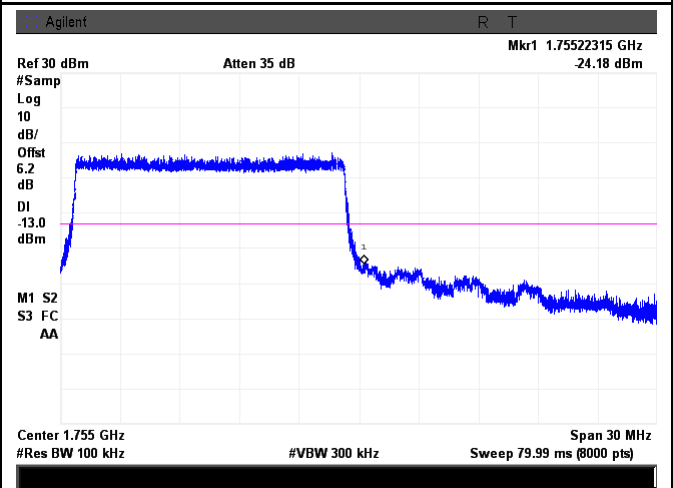

LTE Band 4 - High Channel 16QAM-15

Note: Offset=Cable loss (4.5) + 10log
(147.5/100)=4.5+1.7=6.2 dB

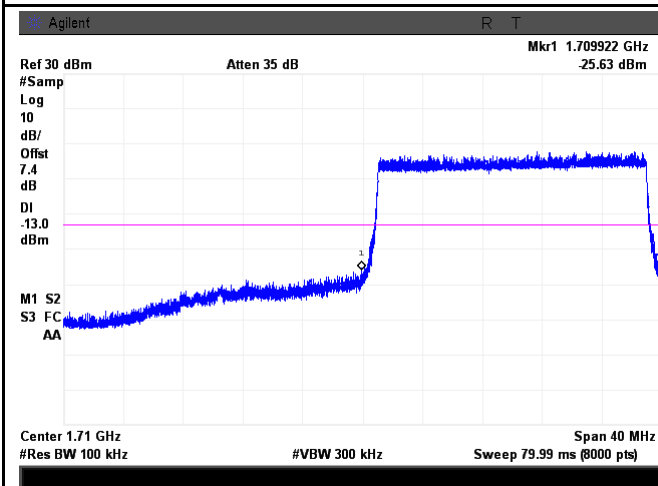

LTE Band 4 - Low Channel QPSK-20

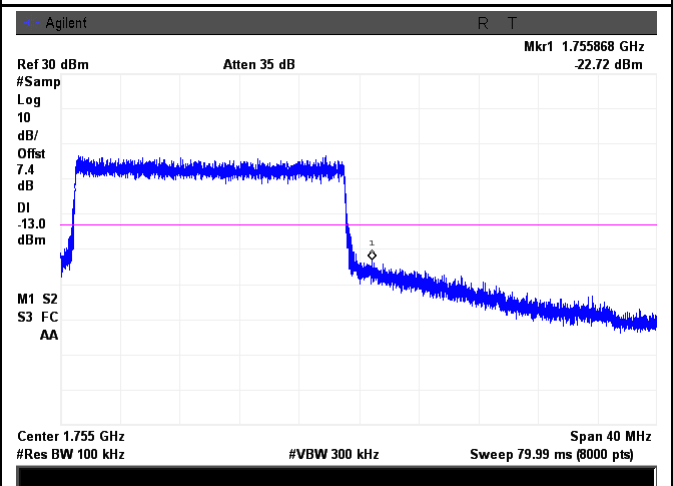

LTE Band 4 - High Channel QPSK-20

Note: Offset=Cable loss (4.5) + 10log
 (192.9/100)=4.5+2.9=7.4 dB

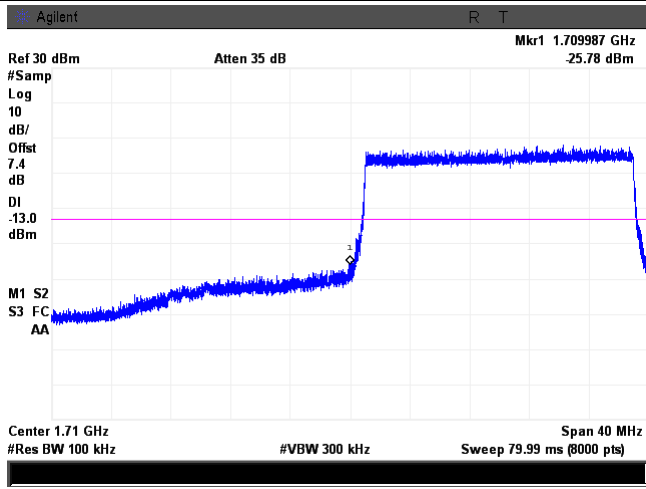

LTE Band 4 - Low Channel 16QAM-20

Note: Offset=Cable loss (4.5) + 10log
 (192.8/100)=4.5+2.9=7.4 dB

Note: Offset=Cable loss (4.5) + 10log
 (196.7/100)=4.5+2.9=7.4 dB

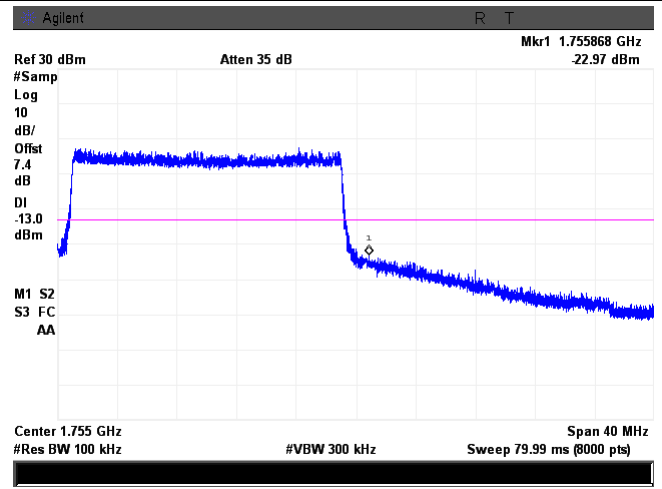

LTE Band 4 - High Channel 16QAM-20

Note: Offset=Cable loss (4.5) + 10log
 (195.8/100)=4.5+2.9=7.4 dB

LTE Band 5 (Part 22H)

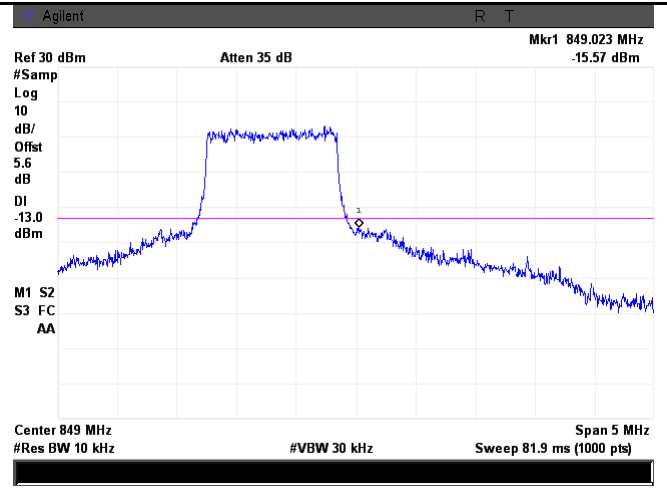
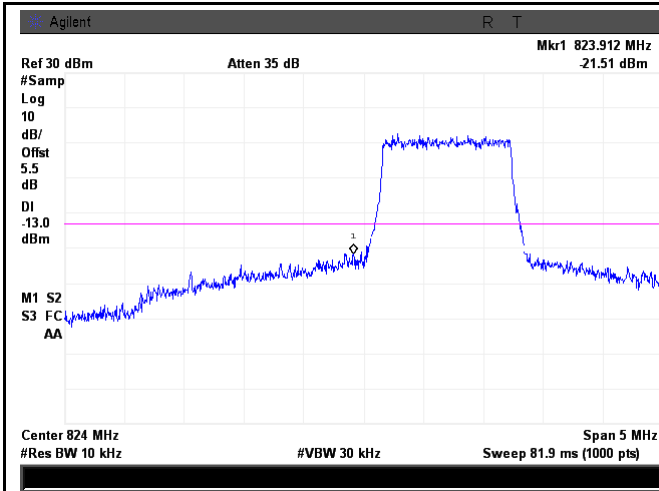

LTE Band 5 - Low Channel QPSK-1.4

LTE Band 5 - High Channel QPSK-1.4

Note: Offset=Cable loss (4.5) + 10log
(12.56/10)=4.5+1.0=5.5 dB

Note: Offset=Cable loss (4.5) + 10log
(12.89/10)=4.5+1.1=5.6 dB

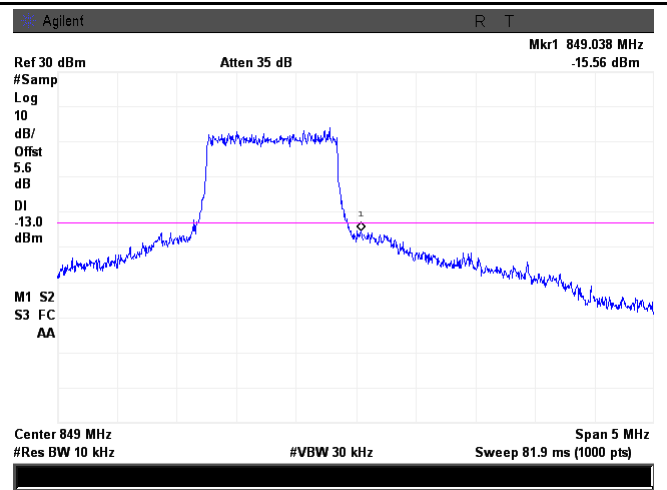
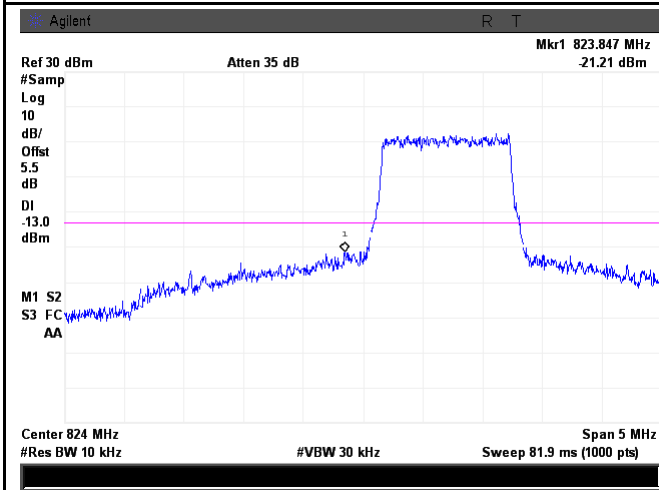

LTE Band 5 - Low Channel 16QAM-1.4

LTE Band 5 - High Channel 16QAM-1.4

Note: Offset=Cable loss (4.5) + 10log
(12.71/10)=4.5+1.0=5.5 dB

Note: Offset=Cable loss (4.5) + 10log
(12.89/10)=4.5+1.1=5.6 dB

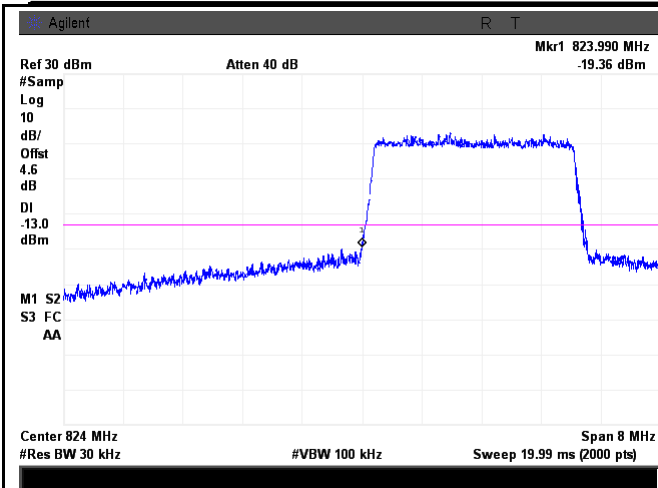

LTE Band 5 - Low Channel QPSK-3

Note: Offset=Cable loss (4.5) + 10log
(30.55/30)=4.5+0.1=4.6 dB

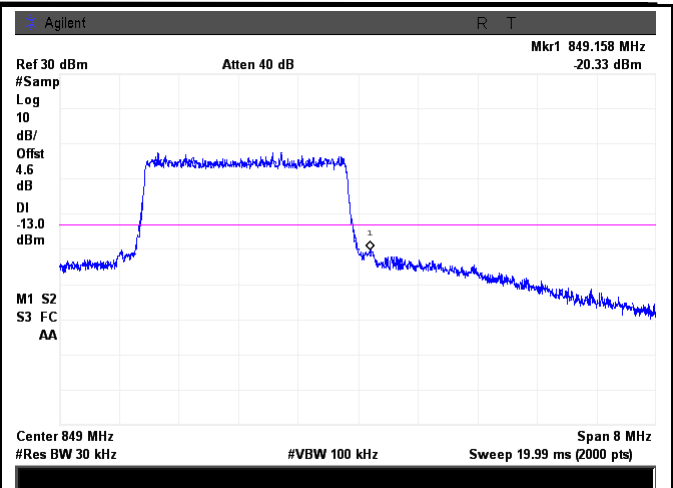

LTE Band 5 - High Channel QPSK-3

Note: Offset=Cable loss (4.5) + 10log
(30.9/30)=4.5+0.1=4.6 dB

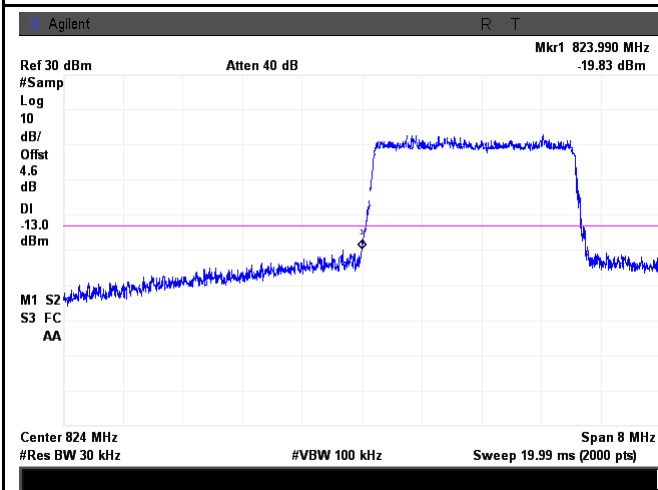

LTE Band 5 - Low Channel 16QAM-3

Note: Offset=Cable loss (4.5) + 10log
(30.62/30)=4.5+0.1=4.6 dB

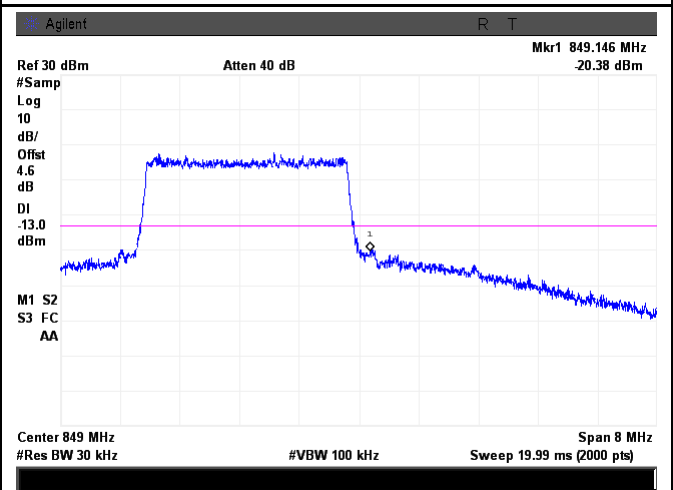

LTE Band 5 - High Channel 16QAM-3

Note: Offset=Cable loss (4.5) + 10log
(30.95/30)=4.5+0.1=4.6 dB

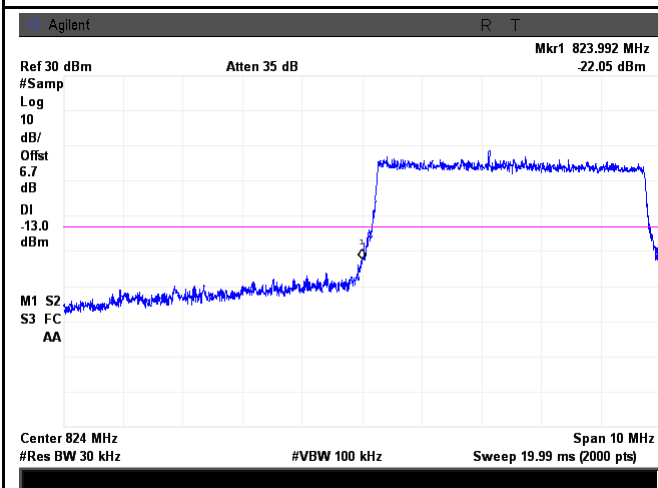

LTE Band 5 - Low Channel QPSK-5

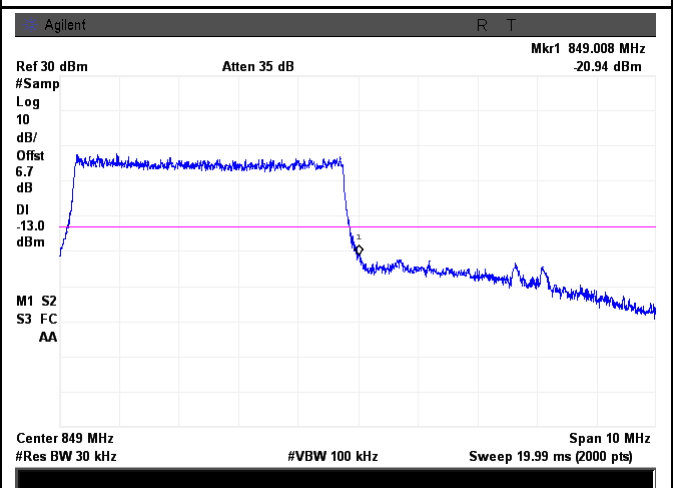

LTE Band 5 - High Channel QPSK-5

Note: Offset=Cable loss (4.5) + 10log
(50.32/30)=4.5+2.2=6.7 dB

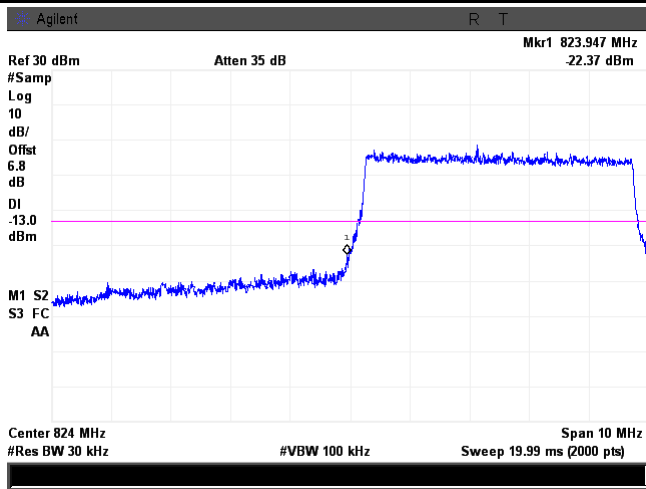

LTE Band 5 - Low Channel 16QAM-5

Note: Offset=Cable loss (4.5) + 10log
(50.07/30)=4.5+2.2=6.7 dB

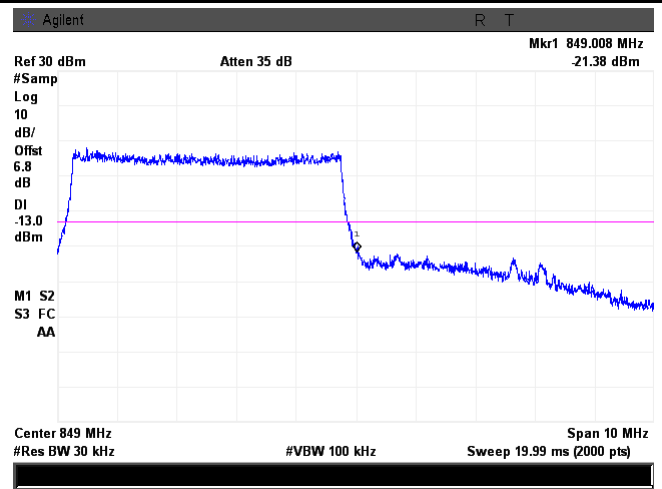

LTE Band 5 - High Channel 16QAM-5

Note: Offset=Cable loss (4.5) + 10log
(50.44/30)=4.5+2.3=6.8 dB

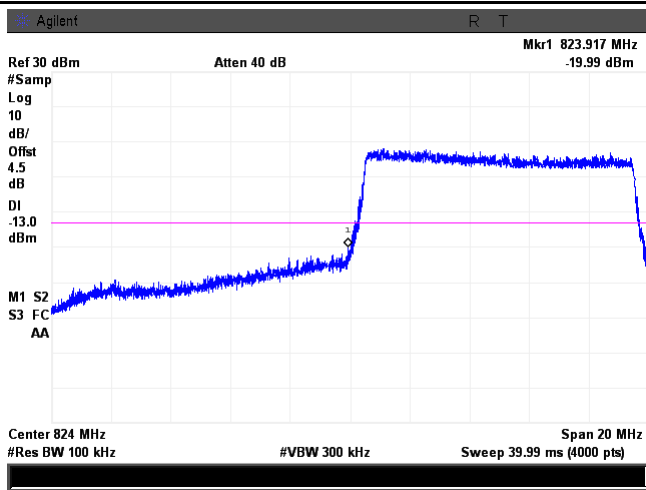

LTE Band 5 - Low Channel QPSK-10

Note: Offset=Cable loss (4.5) + 10log
(50.62/30)=4.5+2.3=6.8 dB

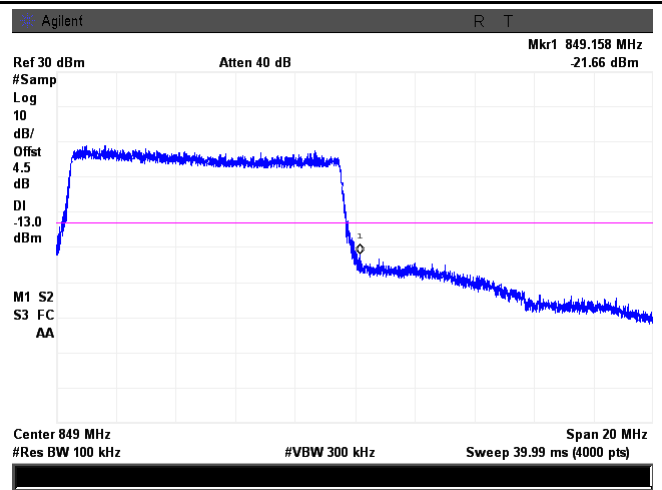

LTE Band 5 - High Channel QPSK-10

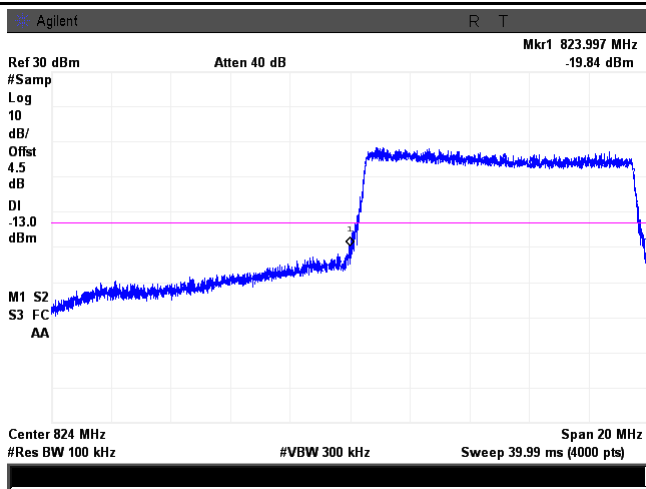

LTE Band 5 - Low Channel 16QAM-10

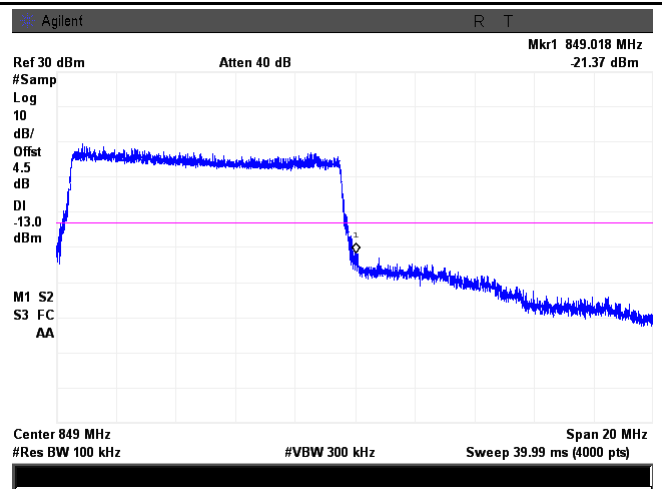

LTE Band 5 - High Channel 16QAM-10

LTE Band 17 (Part 27)

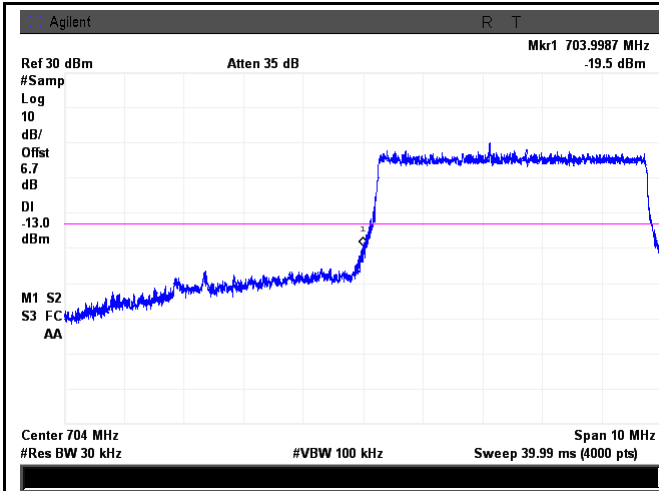

LTE Band 17 - Low Channel QPSK-5

Note: Offset=Cable loss (4.0) + 10log
(49.79/30)=4.5+2.2=6.7 dB

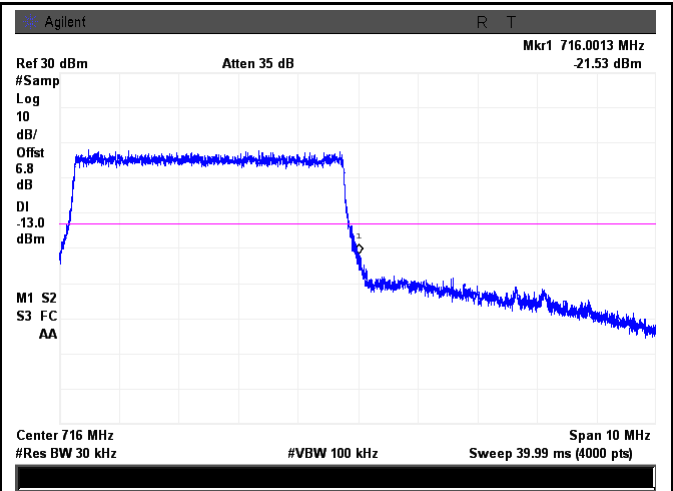

LTE Band 17 - High Channel QPSK-5

Note: Offset=Cable loss (4.0) + 10log
(50.63/30)=4.5+2.3=6.8 dB

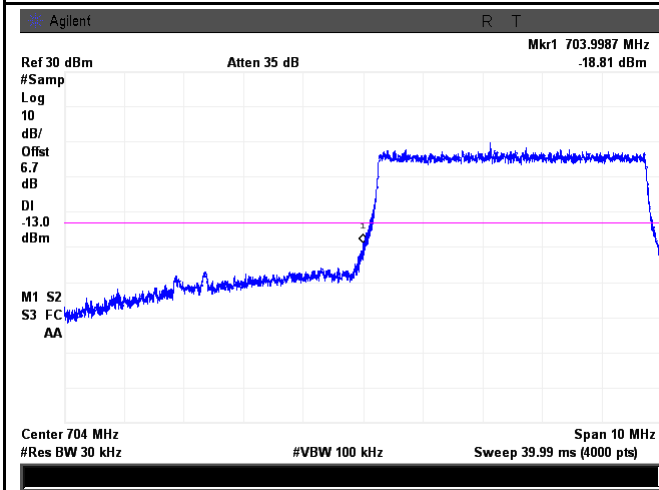

LTE Band 17 - Low Channel 16QAM-5

Note: Offset=Cable loss (4.0) + 10log
(50.19/30)=4.5+2.2=6.7 dB

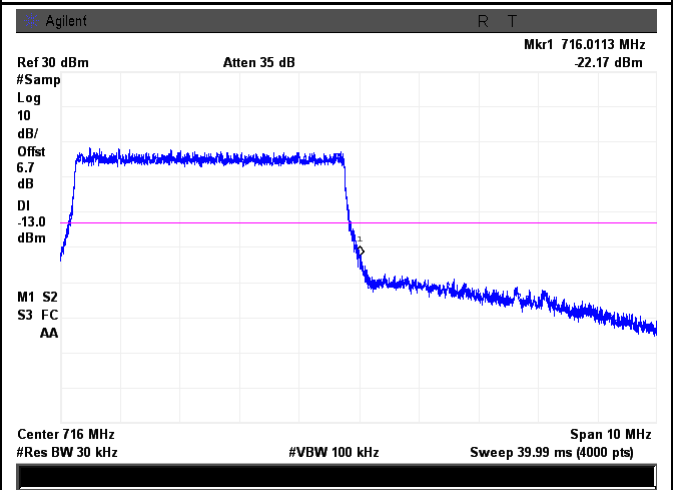

LTE Band 17 - High Channel 16QAM-5

Note: Offset=Cable loss (4.0) + 10log
(50.11/30)=4.5+2.2=6.7 dB

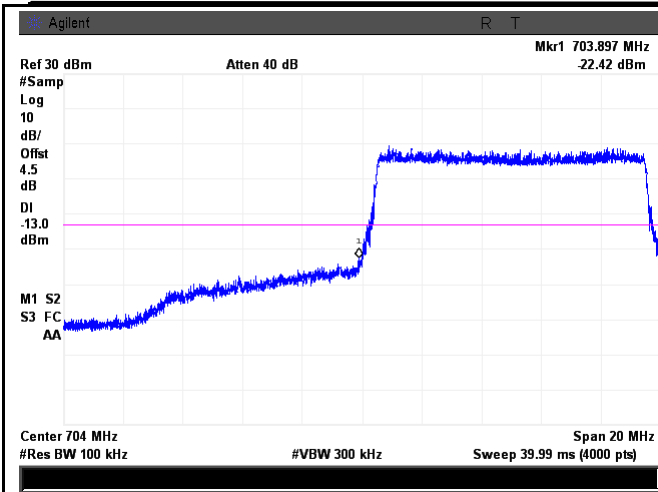

LTE Band 17 - Low Channel QPSK-10

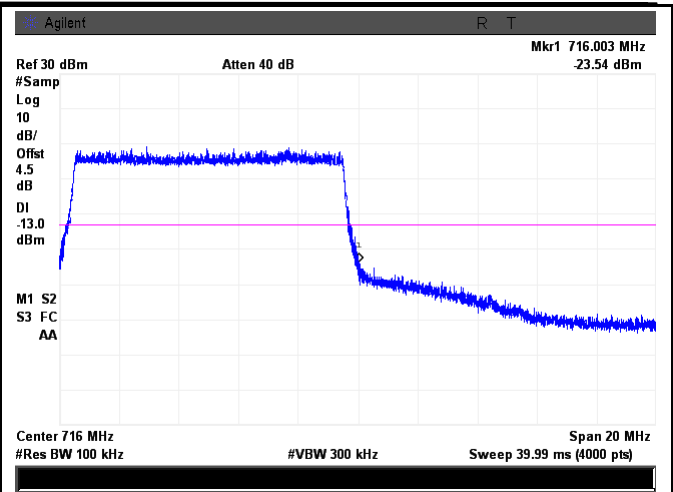

LTE Band 17 - High Channel QPSK-10

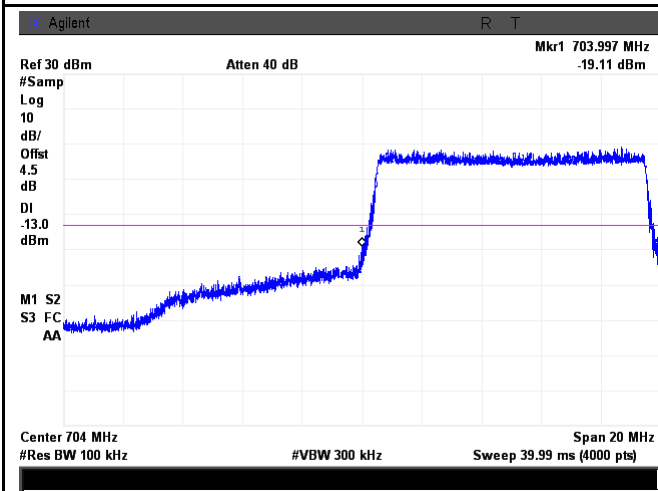

LTE Band 17 - Low Channel 16QAM-10

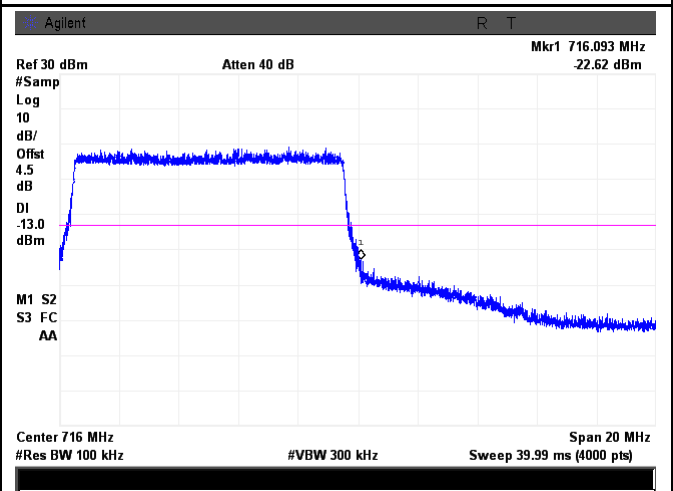

LTE Band 17 - High Channel 16QAM-10

6.9 Band Edge 27.53(m)

Temperature	22°C
Relative Humidity	57%
Atmospheric Pressure	1005mbar
Test date :	November 05, 2015
Tested By :	Winnie Zhang

Requirement(s):

Spec	Requirement	Applicable
§27.53(m)	According to FCC 27.53(m)(4) specified that power of any emission outside of the channel edge must be attenuated below the transmitting power(P) by a factor shall be not less than $43+10\log(P)$ dB at the channel edge, the limit of emission equal to -13dBm. And $55+10\log(P)$ dB at 5.5MHz from the channel edges, the limit of emission equal to -25dBm. In the 1MHz bands immediately outside and adjacent to the frequency block a resolution bandwidth of at least one percent of the emission bandwidth of the fundamental emission of the transmitter may be employed.	<input checked="" type="checkbox"/>
Test Setup	<p style="text-align: center;"> Base Station Spectrum Analyzer EUT </p>	
Test Procedure	<ul style="list-style-type: none"> - The EUT was connected to Spectrum Analyzer and Base Station via power divider. - The 99% and 26 dB occupied bandwidth (BW) of the middle channel for the highest RF powers. 	
Remark		
Result	<input checked="" type="checkbox"/> Pass <input type="checkbox"/> Fail	

Test Data Yes N/A
 Test Plot Yes (See below) N/A

LTE Band 7 (Part 27) result

BW(MHz)	Channel	Frequency (MHz)	Mode	Emission (dBm)	Limit (dBm)
5	20775	2502.5	QPSK	-22.36	-13
			16QAM	-23.96	-13
5	21425	2567.5	QPSK	-26.40	-13
			16QAM	-26.57	-13
10	20800	2505	QPSK	-22.58	-13
			16QAM	-21.94	-13
10	21400	2562.5	QPSK	-25.83	-13
			16QAM	-22.50	-13
15	20825	2507.5	QPSK	-20.14	-13
			16QAM	-20.78	-13
15	21400	2562.5	QPSK	-23.33	-13
			16QAM	-23.32	-13
20	20850	2510	QPSK	-23.27	-13
			16QAM	-21.53	-13
20	21350	2560	QPSK	-25.44	-13
			16QAM	-25.51	-13

LTE Band 7 (Part 27)

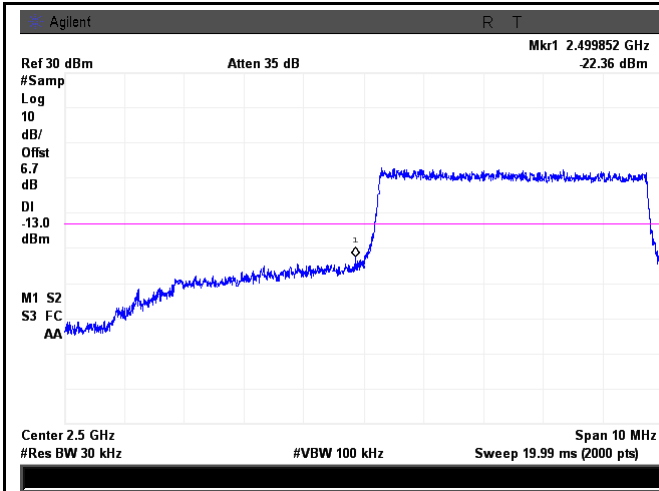

LTE Band 7 - Low Channel QPSK-5

Note: Offset=Cable loss (4.5) + 10log
(49.88/30)=4.5+2.2=6.7 dB

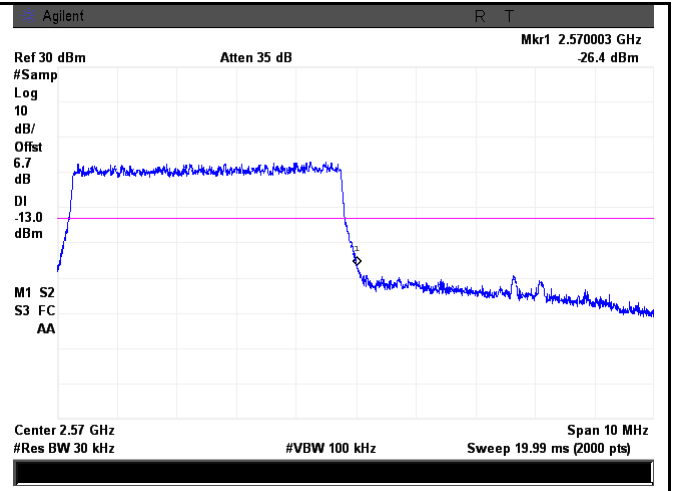

LTE Band 7 - High Channel QPSK-5

Note: Offset=Cable loss (4.5) + 10log
(49.78/30)=4.5+2.2=6.7 dB

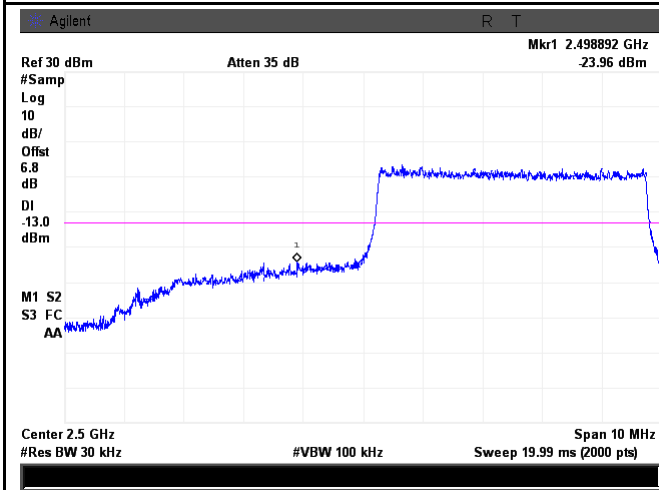

LTE Band 7 - Low Channel 16QAM-5

Note: Offset=Cable loss (4.5) + 10log
(50.99/30)=4.5+2.3=6.8 dB

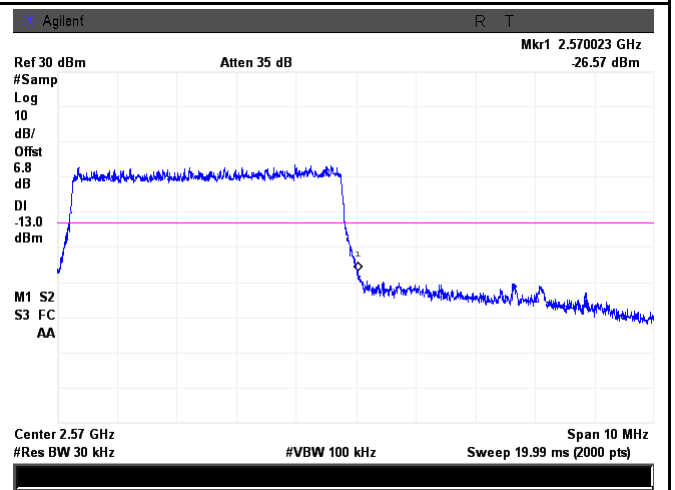

LTE Band 7 - High Channel 16QAM-5

Note: Offset=Cable loss (4.5) + 10log
(50.51/30)=4.5+2.3=6.8 dB

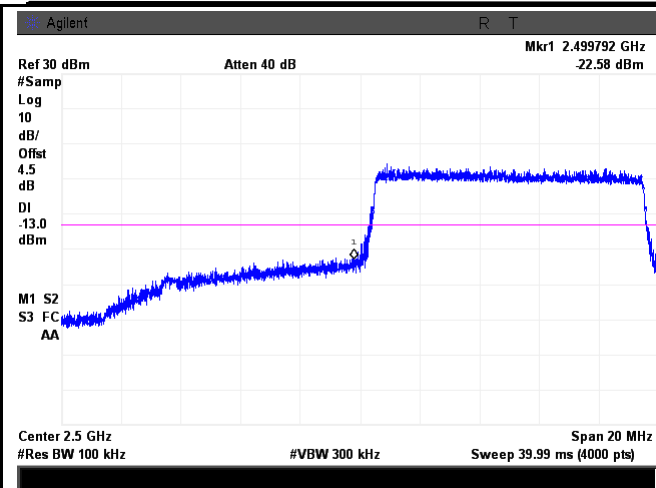

LTE Band 7 - Low Channel QPSK-10

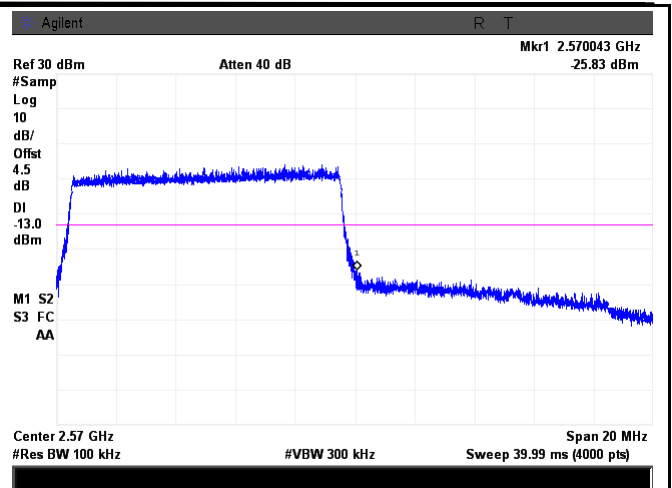

LTE Band 7 - High Channel QPSK-10

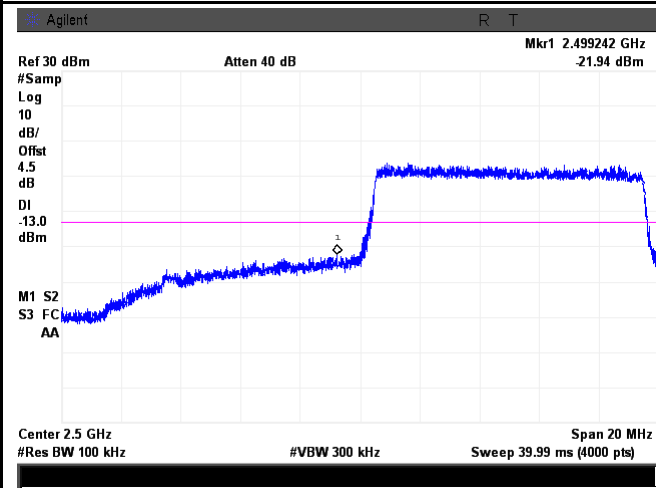

LTE Band 7 - Low Channel 16QAM-10

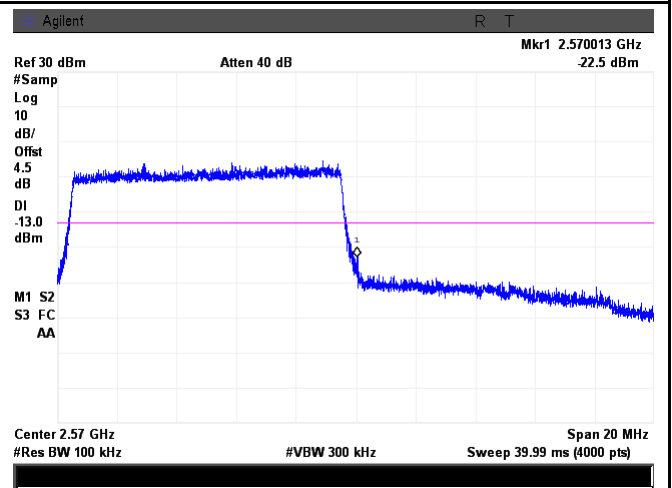

LTE Band 7 - High Channel 16QAM-10

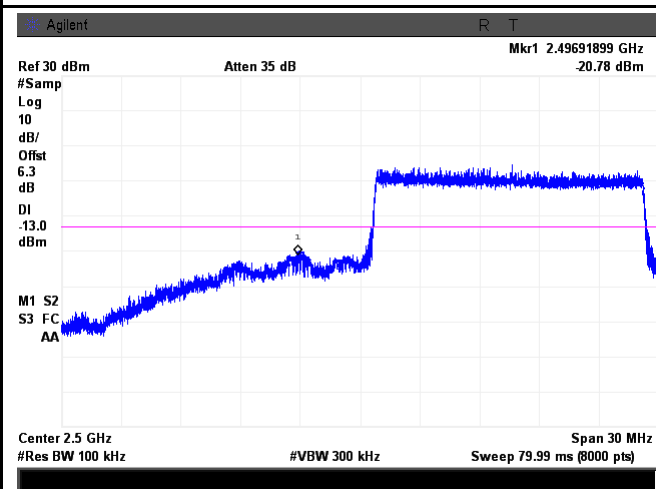

LTE Band 7 - Low Channel QPSK-15

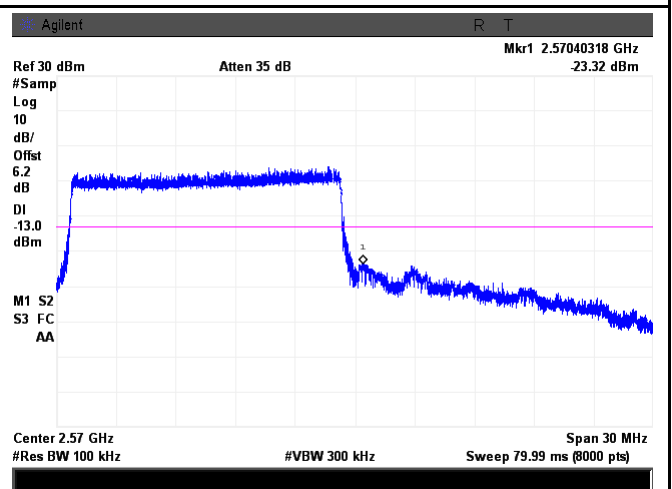

LTE Band 7 - High Channel QPSK-15

Note: Offset=Cable loss (4.5) + 10log
(150.5/100)=4.5+1.8=6.3 dB

Note: Offset=Cable loss (4.5) + 10log
(147.9/100)=4.5+1.7=6.2 dB

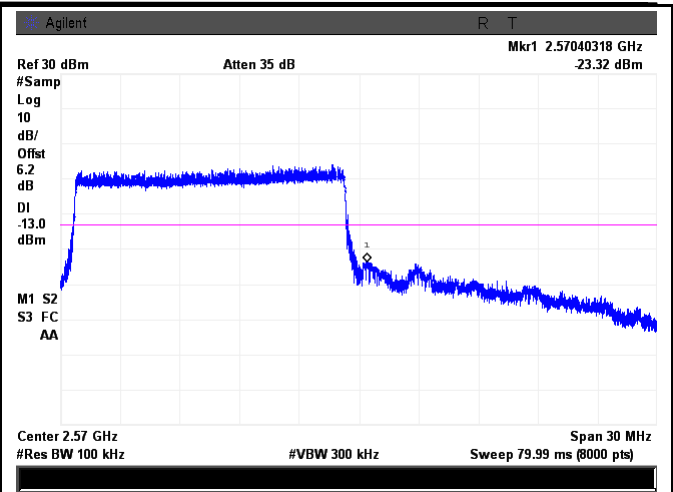
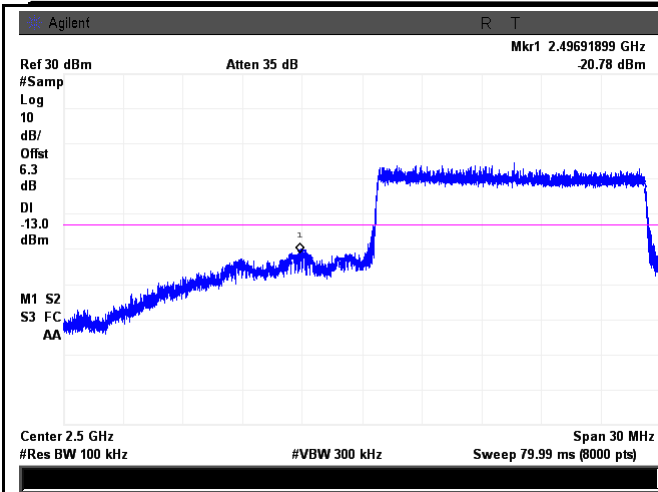

LTE Band 7 - Low Channel 16QAM-15

LTE Band 7 - High Channel 16QAM-15

Note: Offset=Cable loss (4.5) + 10log
(152.6/100)=4.5+1.8=6.3 dB

Note: Offset=Cable loss (4.5) + 10log
(148.2/100)=4.5+1.7=6.2 dB

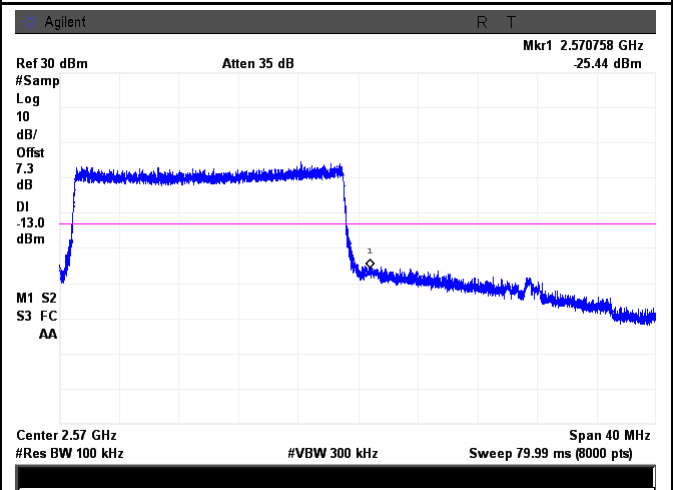
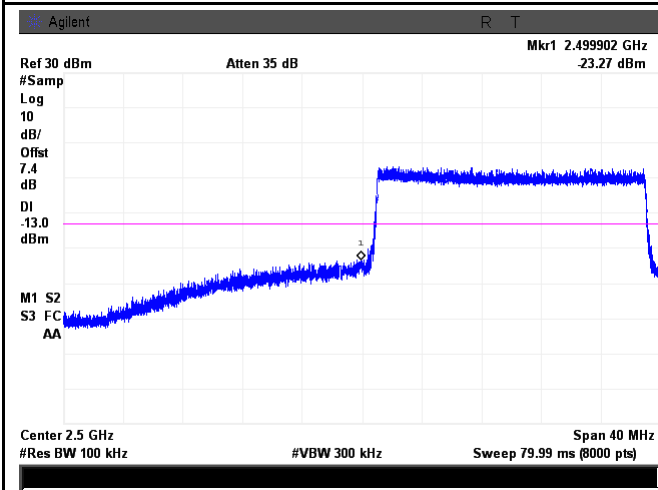

LTE Band 7 - Low Channel QPSK-20

LTE Band 7 - High Channel QPSK-20

Note: Offset=Cable loss (4.5) + 10log
(194.3/100)=4.5+2.7=7.4 dB

Note: Offset=Cable loss (4.5) + 10log
(192.7/100)=4.5+2.8=7.3 dB

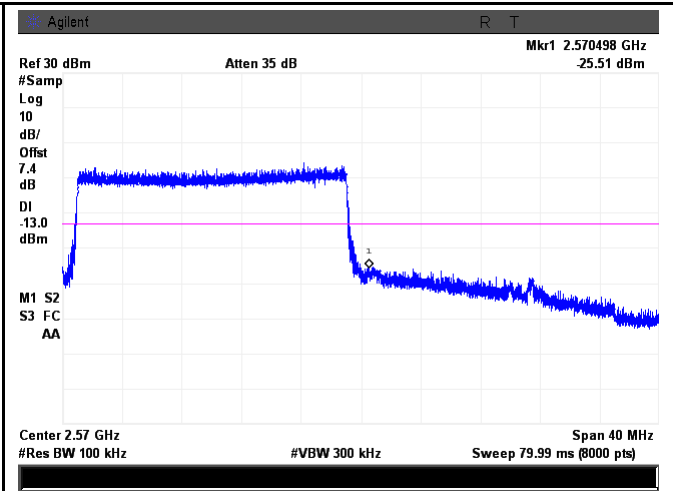
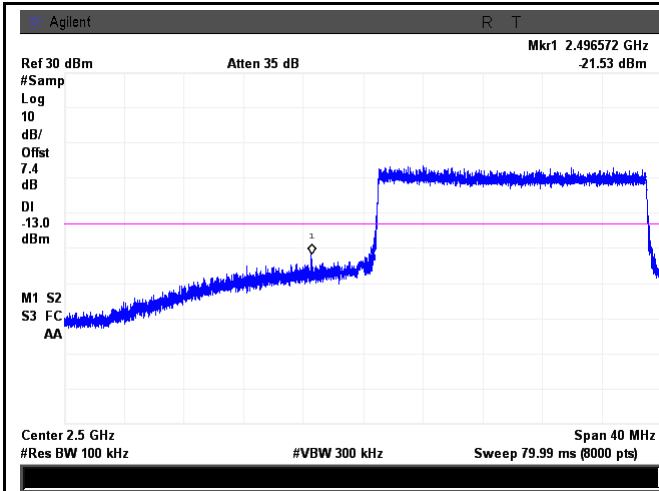

LTE Band 7 - Low Channel 16QAM-20

LTE Band 7 - High Channel 16QAM-20

Note: Offset=Cable loss (4.5) + 10log
 (194.9/100)=4.5+2.9=7.4 dB

Note: Offset=Cable loss (4.5) + 10log
 (194.3/100)=4.5+2.9=7.4 dB

6.10 Frequency Stability

Temperature	22°C
Relative Humidity	57%
Atmospheric Pressure	1005mbar
Test date :	November 05, 2015
Tested By :	Winnie Zhang

Requirement(s):

Spec	Item	Requirement	Applicable																																
§2.1055, §22.355 & §24.235 § 27.5(h); § 27.54	a)	<p>According to §22.355, the carrier frequency of each transmitter in the Public Mobile Services must be maintained within the tolerances given in Table below:</p> <p>Frequency Tolerance for Transmitters in the Public Mobile Services</p> <table border="1"> <thead> <tr> <th>Frequency Range (MHz)</th> <th>Base, fixed (ppm)</th> <th>Mobile ≤ 3 watts (ppm)</th> <th>Mobile ≤ 3 watts (ppm)</th> </tr> </thead> <tbody> <tr> <td>25 to 50</td> <td>20.0</td> <td>20.0</td> <td>50.0</td> </tr> <tr> <td>to 450</td> <td>5.0</td> <td>5.0</td> <td>50.0</td> </tr> <tr> <td>450 to 512</td> <td>2.5</td> <td>5.0</td> <td>5 0</td> </tr> <tr> <td>821 to 896</td> <td>1.5</td> <td>2.5</td> <td>2.5</td> </tr> <tr> <td>928 to 929.</td> <td>5.0</td> <td>N/A</td> <td>N/A</td> </tr> <tr> <td>929 to 960.</td> <td>1.5</td> <td>N/A</td> <td>N/A</td> </tr> <tr> <td>2110 to 2220</td> <td>10.0</td> <td>N/A</td> <td>N/A</td> </tr> </tbody> </table> <p>According to §24.235, the frequency stability shall be sufficient to ensure that the fundamental emissions stay within the authorized frequency block.</p> <p>According to §27.54, The frequency stability shall be sufficient to ensure that the fundamental emissions stay within the authorized bands of operation.</p>	Frequency Range (MHz)	Base, fixed (ppm)	Mobile ≤ 3 watts (ppm)	Mobile ≤ 3 watts (ppm)	25 to 50	20.0	20.0	50.0	to 450	5.0	5.0	50.0	450 to 512	2.5	5.0	5 0	821 to 896	1.5	2.5	2.5	928 to 929.	5.0	N/A	N/A	929 to 960.	1.5	N/A	N/A	2110 to 2220	10.0	N/A	N/A	<input checked="" type="checkbox"/>
		Frequency Range (MHz)	Base, fixed (ppm)	Mobile ≤ 3 watts (ppm)	Mobile ≤ 3 watts (ppm)																														
		25 to 50	20.0	20.0	50.0																														
		to 450	5.0	5.0	50.0																														
		450 to 512	2.5	5.0	5 0																														
		821 to 896	1.5	2.5	2.5																														
		928 to 929.	5.0	N/A	N/A																														
		929 to 960.	1.5	N/A	N/A																														
		2110 to 2220	10.0	N/A	N/A																														

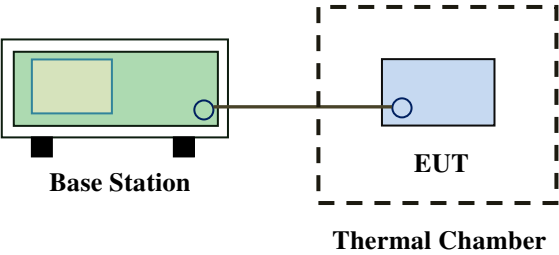
Test setup	 <p>The diagram illustrates the test setup. On the left, a green rectangular box labeled 'Base Station' is shown with two black feet. A horizontal line connects it to a blue rectangular box labeled 'EUT' (Equipment Under Test) located inside a dashed-line rectangular box labeled 'Thermal Chamber'. Both the Base Station and the EUT have a small circle on their right side, representing a connection point.</p>
Procedure	<p>A communication link was established between EUT and base station. The frequency error was monitored and measured by base station under variation of ambient temperature and variation of primary supply voltage.</p> <p>Limit: The frequency stability of the transmitter shall be maintained within $\pm 0.00025\%$ ($\pm 2.5\text{ppm}$) of the center frequency.</p>
Remark	<p>Frequency Stability versus Temperature: The Frequency tolerance of the carrier signal shall be maintained within 2.5ppm of the operating frequency over a temperature variation of -10°C to $+55^{\circ}\text{C}$ at normal supply voltage.</p>
Result	<p><input checked="" type="checkbox"/> Pass <input type="checkbox"/> Fail</p>

Test Data Yes N/A

Test Plot Yes (See below) N/A

LTE Band 2 (Part 24E) result

Middle Channel, $f_0 = 1880$ MHz				
Temperature (°C)	Power Supplied (V _{DC})	Frequency Error (Hz)	Frequency Error (ppm)	Limit (ppm)
-10	3.7	-6	0.0032	2.5
0		-10	0.0053	2.5
10		-6	0.0032	2.5
20		-11	0.0059	2.5
30		-11	0.0059	2.5
40		-8	0.0043	2.5
50		-12	0.0064	2.5
55		-9	0.0048	2.5
25	4.2	-10	0.0053	2.5
	3.5	-10	0.0053	2.5

LTE Band 4 (Part 27) result

Middle Channel, $f_0 = 1732.5$ MHz				
Temperature (°C)	Power Supplied (V _{DC})	Frequency Error (Hz)	Frequency Error (ppm)	Limit (ppm)
-10	3.7	-13	0.0075	2.5
0		-12	0.0069	2.5
10		-12	0.0069	2.5
20		-13	0.0075	2.5
30		-11	0.0063	2.5
40		-11	0.0063	2.5
50		-15	0.0087	2.5
55		-13	0.0075	2.5
25	4.2	-12	0.0069	2.5
	3.5	-15	0.0087	2.5

LTE Band 5 (Part 22H) result

Middle Channel, $f_0 = 1732.5$ MHz				
Temperature (°C)	Power Supplied (V _{DC})	Frequency Error (Hz)	Frequency Error (ppm)	Limit (ppm)
-10	3.7	7	0.0084	2.5
0		6	0.0072	2.5
10		7	0.0084	2.5
20		9	0.0108	2.5
30		10	0.0120	2.5
40		13	0.0155	2.5
50		9	0.0108	2.5
55		10	0.0120	2.5
25	4.2	8	0.0096	2.5
	3.5	11	0.0132	2.5

LTE Band 7 (Part 27) result

Middle Channel, $f_0 = 2535$ MHz				
Temperature (°C)	Power Supplied (V _{DC})	Frequency Error (Hz)	Frequency Error (ppm)	Limit (ppm)
-10	3.7	-10	0.0053	2.5
0		-8	0.0043	2.5
10		-11	0.0059	2.5
20		-12	0.0064	2.5
30		-9	0.0048	2.5
40		-8	0.0043	2.5
50		-12	0.0064	2.5
55		-11	0.0059	2.5
25	4.2	-9	0.0048	2.5
	3.5	-13	0.0069	2.5

LTE Band 17 (Part 27) result

Middle Channel, $f_0 = 710$ MHz				
Temperature (°C)	Power Supplied (V _{DC})	Frequency Error (Hz)	Frequency Error (ppm)	Limit (ppm)
-10	3.7	9	0.0127	2.5
0		8	0.0113	2.5
10		5	0.0070	2.5
20		7	0.0099	2.5
30		6	0.0085	2.5
40		11	0.0155	2.5
50		12	0.0169	2.5
55		7	0.0099	2.5
25	4.2	8	0.0113	2.5
	3.5	10	0.0141	2.5

Annex A. TEST INSTRUMENT

Instrument	Model	Serial #	Cal Date	Cal Due	In use
RF Conducted Test					
Agilent ESA-E SERIES SPECTRUM ANALYZER	E4407B	MY45108319	09/16/2015	09/15/2016	<input checked="" type="checkbox"/>
Power Splitter	1#	1#	09/01/2015	08/31/2016	<input checked="" type="checkbox"/>
Universal Radio Communication Tester	CMU200	121393	09/25/2015	09/24/2016	<input checked="" type="checkbox"/>
Wideband Radio Communication Tester	CMW500	120906	03/28/2015	03/27/2016	<input checked="" type="checkbox"/>
Temperature/Humidity Chamber	UHL-270	001	10/09/2015	10/08/2016	<input checked="" type="checkbox"/>
DC Power Supply	E3640A	MY40004013	09/17/2015	09/16/2016	<input checked="" type="checkbox"/>
Radiated Emissions					
EMI test receiver	ESL6	100262	09/17/2015	09/16/2016	<input checked="" type="checkbox"/>
OPT 010 AMPLIFIER (0.1-1300MHz)	8447E	2727A02430	09/01/2015	08/31/2016	<input checked="" type="checkbox"/>
Microwave Preamplifier (0.5 ~ 18GHz)	PAM-118	443008	09/01/2015	08/31/2016	<input checked="" type="checkbox"/>
Bilog Antenna (30MHz~6GHz)	JB6	A110712	09/21/2015	09/20/2016	<input checked="" type="checkbox"/>
Bilog Antenna (30MHz~2GHz)	JB1	A112017	09/21/2015	09/20/2016	<input checked="" type="checkbox"/>
Double Ridge Horn Antenna (1 ~18GHz)	AH-118	71259	09/24/2015	09/23/2016	<input checked="" type="checkbox"/>
Double Ridge Horn Antenna (1 ~18GHz)	AH-118	71283	09/24/2015	09/23/2016	<input checked="" type="checkbox"/>
SYNTHESIZED SIGNAL GENERATOR	8665B	3744A01293	09/17/2015	09/16/2016	<input checked="" type="checkbox"/>
Tunable Notch Filter	3NF-800/1000-S	AA4	09/01/2015	08/31/2016	<input checked="" type="checkbox"/>
Tunable Notch Filter	3NF-1000/2000-S	AM 4	09/01/2015	08/31/2016	<input checked="" type="checkbox"/>

Annex B. EUT And Test Setup Photographs

Annex B.i. Photograph: EUT External Photo

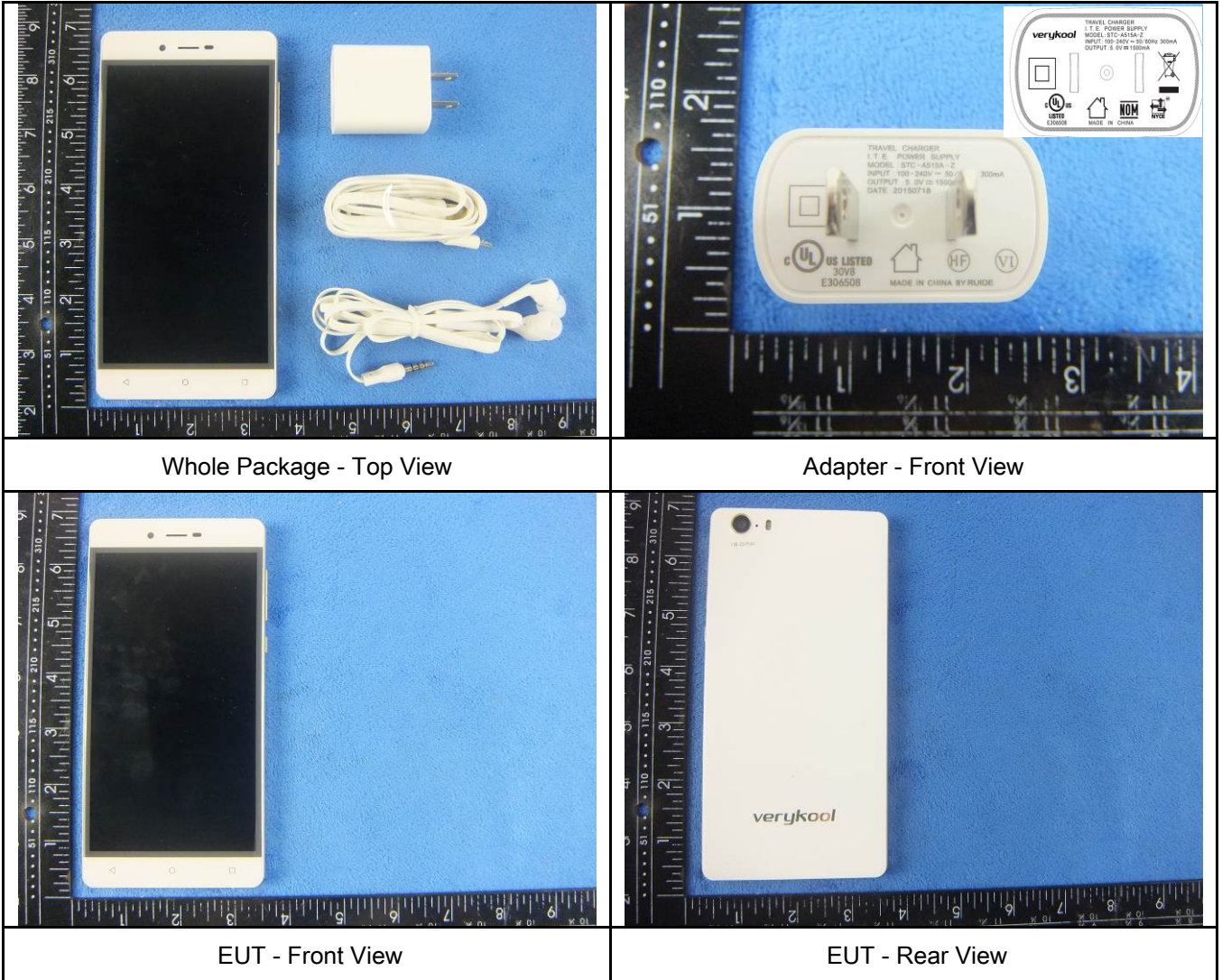



EUT - Top View



EUT - Bottom View

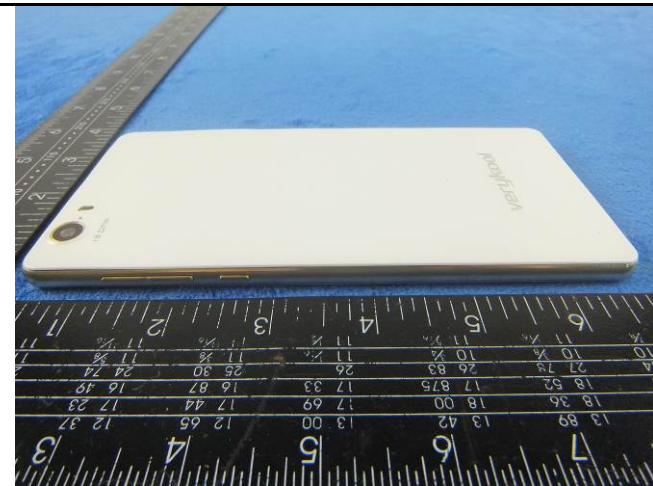

EUT - Left View

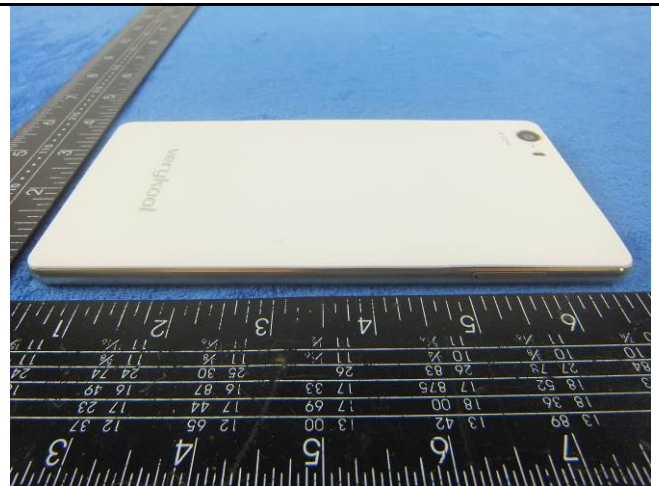

EUT - Right View

Annex B.ii. Photograph: EUT Internal Photo

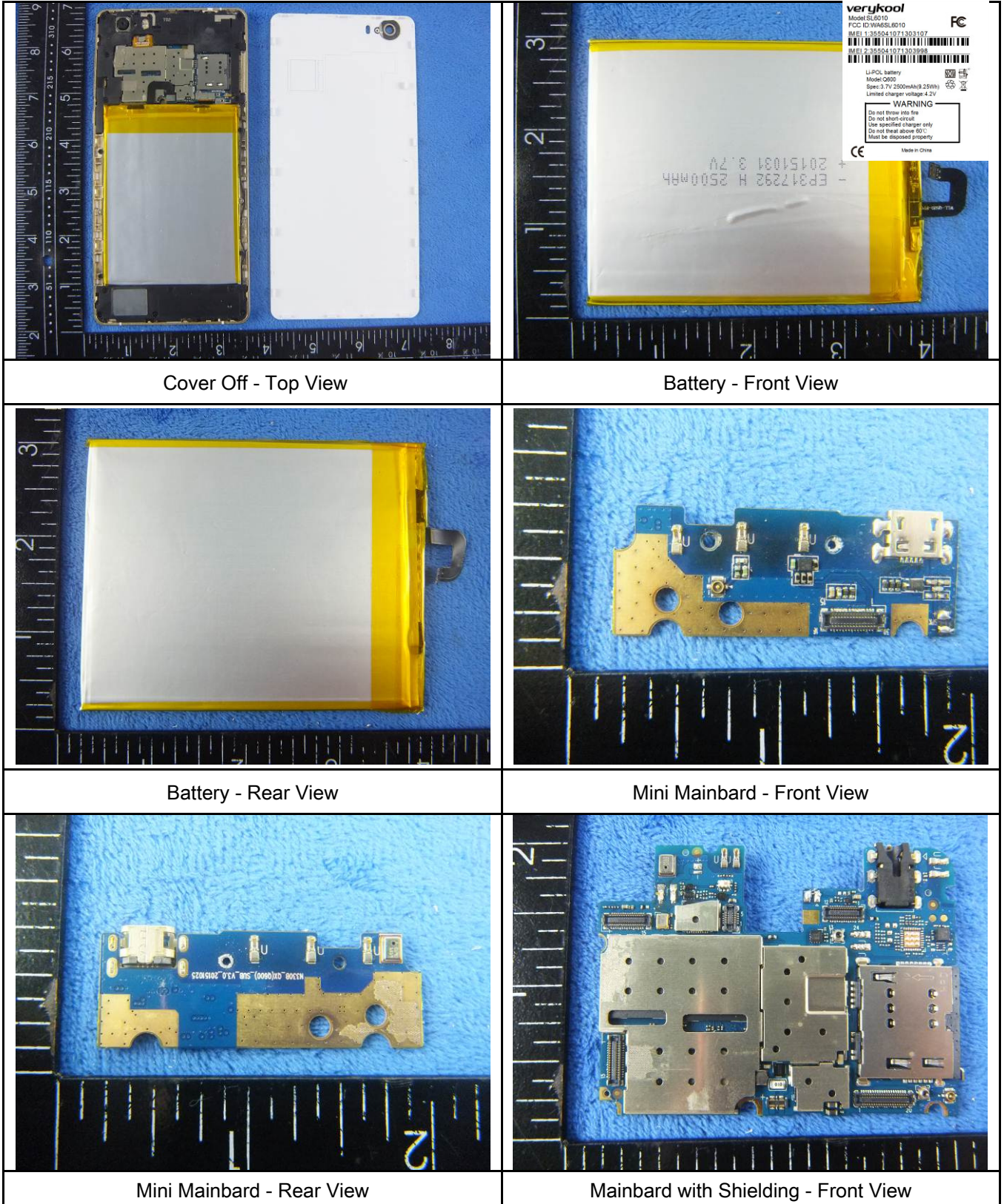

Cover Off - Top View

Battery - Front View

Battery - Rear View

Mini Mainboard - Front View

Mini Mainboard - Rear View

Mainboard with Shielding - Front View

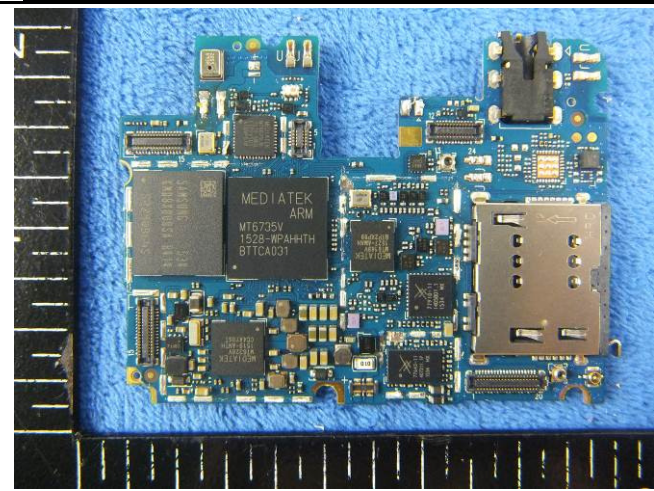

Mainboard without Shielding - Front View

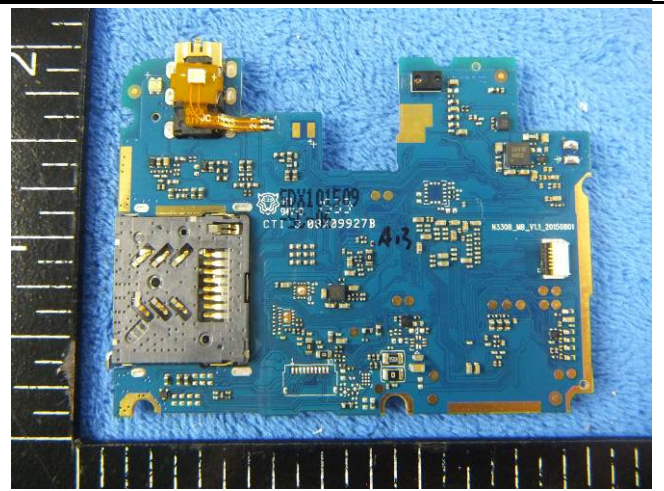

Mainboard - Rear View



LCD - Front View

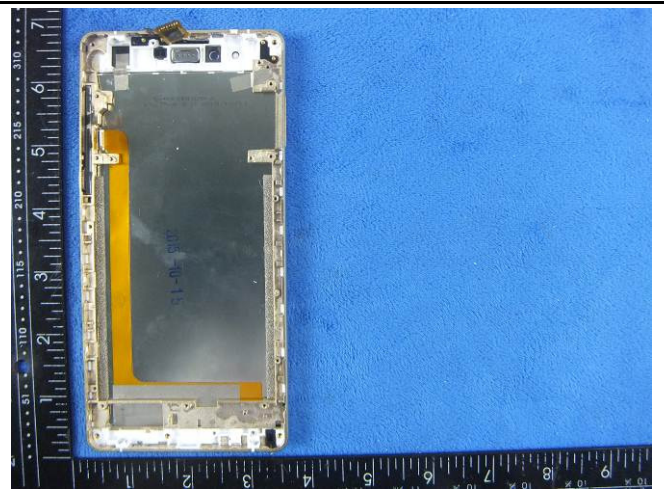

LCD - Rear View

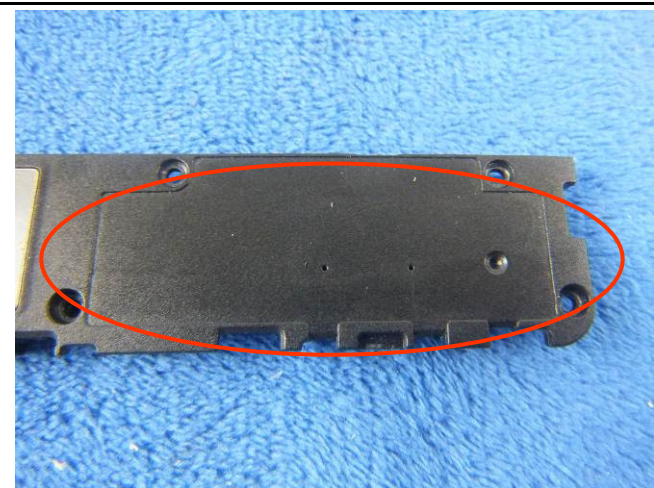

GSM/PCS/UMTS-FDD/LTE Antenna View

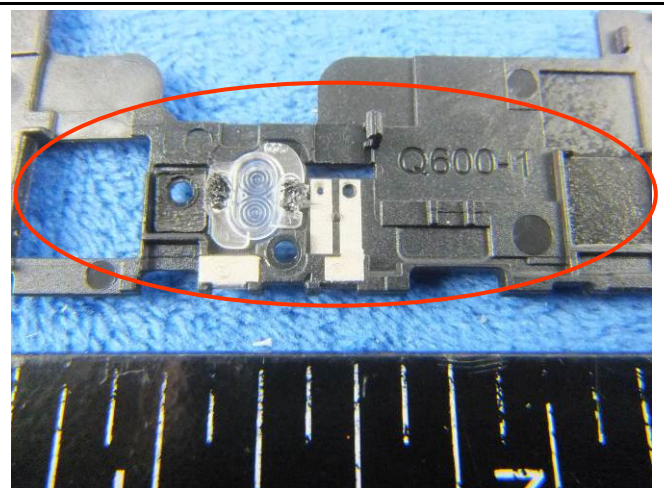

WIFI/BT/BLE - Antenna View

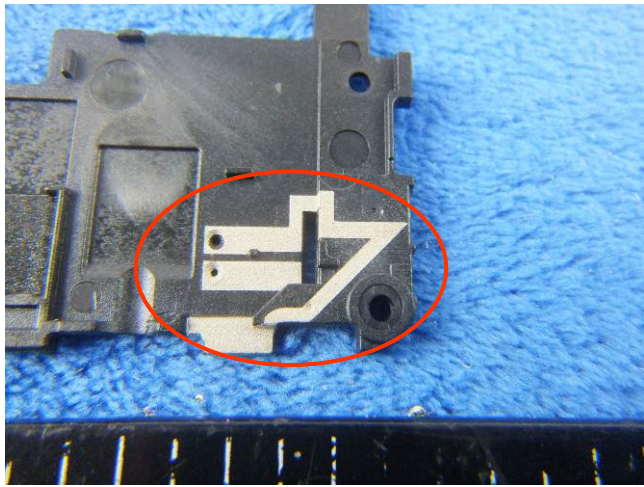

GPS - Antenna View

Annex B.iii. Photograph: Test Setup Photo

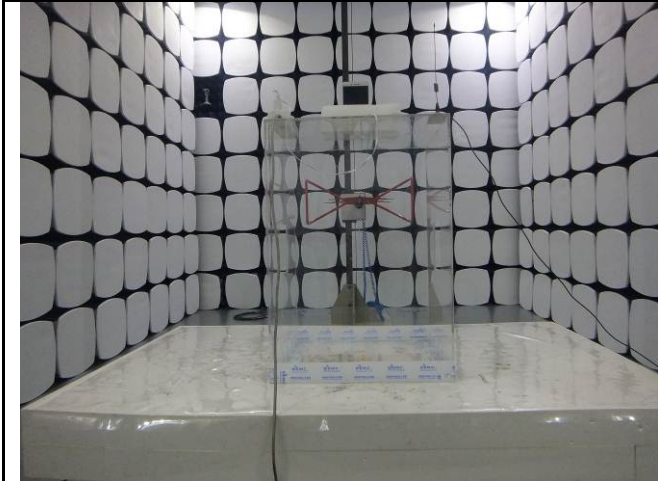

Radiated Spurious Emissions Test Setup Below 1GHz

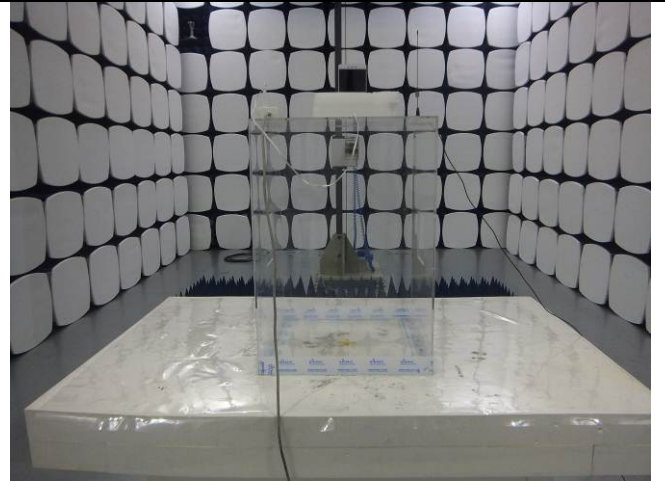

Radiated Spurious Emissions Test Setup Above
1GHz

Annex C. TEST SETUP AND SUPPORTING EQUIPMENT

Annex C.ii. TEST SET UP BLOCK

Block Configuration Diagram for Radiated Emissions

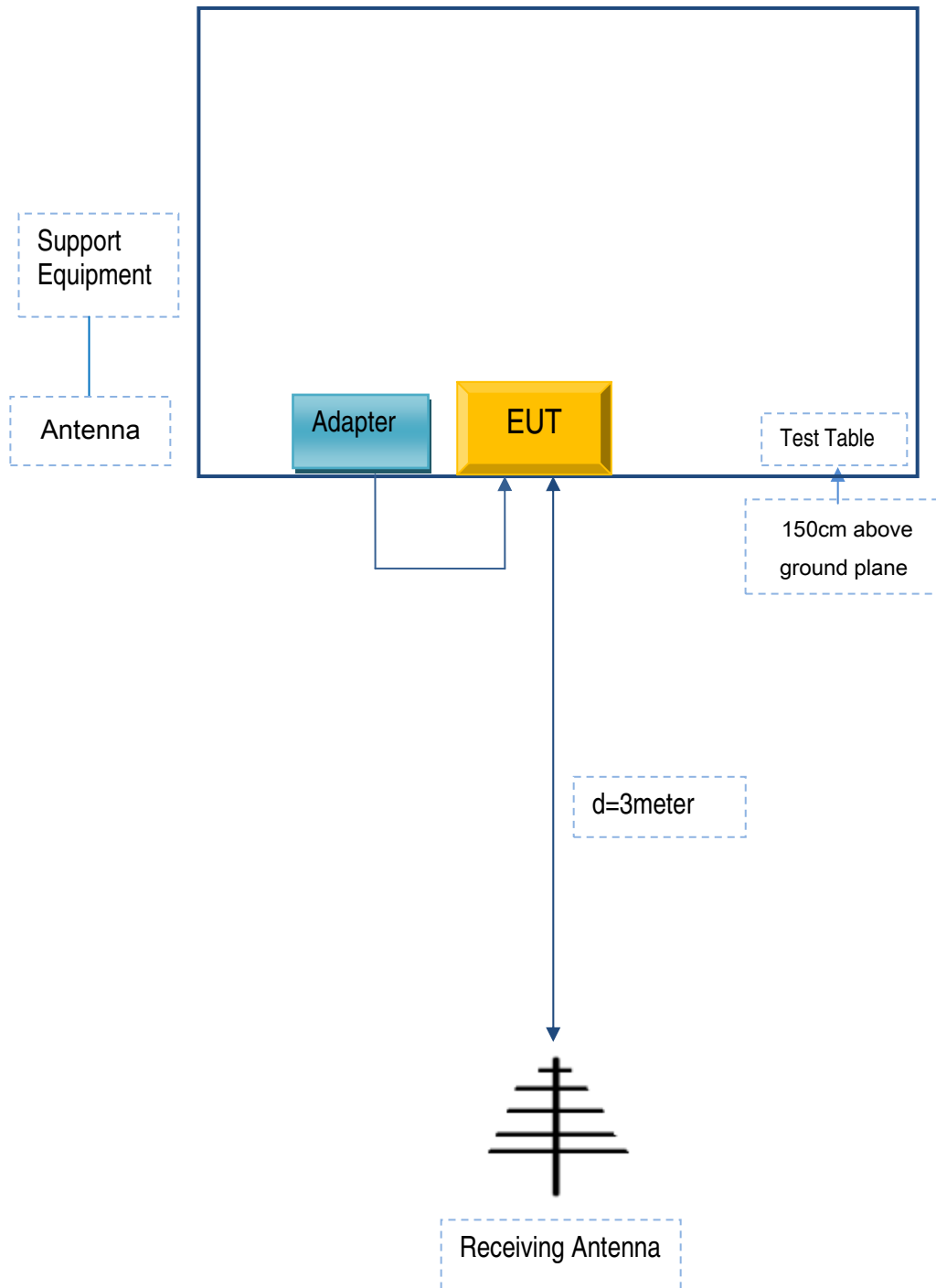

Annex C. ii. SUPPORTING EQUIPMENT DESCRIPTION

The following is a description of supporting equipment and details of cables used with the EUT.

Manufacturer	Equipment Description	Model	Calibration Date	Calibration Due Date
N/A	N/A	N/A	N/A	N/A

Test Report	15070962-FCC-R5
Page	131 of 133

Annex C.ii. EUT OPERATING CONKITIONS

N/A

Test Report	15070962-FCC-R5
Page	132 of 133

Annex D. User Manual / Block Diagram / Schematics / Partlist

Please see attachment

Test Report	15070962-FCC-R5
Page	133 of 133

Annex E. DECLARATION OF SIMILARITY

N/A