

# RF TEST REPORT



Report No.: 16071314-FCC-R1-V1

Supersede Report No.: N/A

Applicant	Verykool USA Inc	
Product Name	Mobile Phone	
Model No.	SL5560	
Serial No.	N/A	
Test Standard	FCC Part 22(H):2015 ;FCC Part 24(E):2015; FCC Part 27:2015; ANSI/TIA-603-D: 2010	
Test Date	November 16 to December 01, 2016	
Issue Date	December 14, 2016	
Test Result	<input checked="" type="checkbox"/> Pass <input type="checkbox"/> Fail	
Equipment complied with the specification	<input checked="" type="checkbox"/>	
Equipment did not comply with the specification	<input type="checkbox"/>	
		
Loren Luo Test Engineer	David Huang Checked By	
This test report may be reproduced in full only Test result presented in this test report is applicable to the tested sample only		

Issued by:

**SIEMIC (SHENZHEN-CHINA) LABORATORIES**

Zone A, Floor 1, Building 2 Wan Ye Long Technology Park

South Side of Zhoushi Road, Bao' an District, Shenzhen, Guangdong China 518108

Phone: +86 0755 2601 4629801 Email: [China@siemic.com.cn](mailto:China@siemic.com.cn)

## Laboratories Introduction

SIEMIC, headquartered in the heart of Silicon Valley, with superior facilities in US and Asia, is one of the leading independent testing and certification facilities providing customers with one-stop shop services for Compliance Testing and Global Certifications.



In addition to testing and certification, SIEMIC provides initial design reviews and compliance management throughout a project. Our extensive experience with China, Asia Pacific, North America, European, and International compliance requirements, assures the fastest, most cost effective way to attain regulatory compliance for the global markets.

### Accreditations for Conformity Assessment

Country/Region	Scope
USA	EMC, RF/Wireless, SAR, Telecom
Canada	EMC, RF/Wireless, SAR, Telecom
Taiwan	EMC, RF, Telecom, SAR, Safety
Hong Kong	RF/Wireless, SAR, Telecom
Australia	EMC, RF, Telecom, SAR, Safety
Korea	EMI, EMS, RF, SAR, Telecom, Safety
Japan	EMI, RF/Wireless, SAR, Telecom
Singapore	EMC, RF, SAR, Telecom
Europe	EMC, RF, SAR, Telecom, Safety

Test Report	16071314-FCC-R1-V1
Page	3 of 99

This page has been left blank intentionally.

# CONTENTS

1. REPORT REVISION HISTORY .....	5
2. CUSTOMER INFORMATION .....	5
3. TEST SITE INFORMATION.....	5
4. EQUIPMENT UNDER TEST (EUT) INFORMATION.....	6
5. TEST SUMMARY .....	10
6. MEASUREMENTS, EXAMINATION AND DERIVED RESULTS .....	11
6.1 RF EXPOSURE (SAR).....	11
6.2 RF OUTPUT POWER.....	12
6.3 PEAK-AVERAGE RATIO.....	25
6.4 OCCUPIED BANDWIDTH.....	30
6.5 SPURIOUS EMISSIONS AT ANTENNA TERMINALS.....	45
6.6 SPURIOUS RADIATED EMISSIONS.....	61
6.7 BAND EDGE.....	68
6.8 FREQUENCY STABILITY .....	82
ANNEX A. TEST INSTRUMENT.....	87
ANNEX B. EUT AND TEST SETUP PHOTOGRAPHS.....	89
ANNEX C. TEST SETUP AND SUPPORTING EQUIPMENT.....	95
ANNEX C.II. EUT OPERATING CONKITIONS.....	97
ANNEX D. USER MANUAL / BLOCK DIAGRAM / SCHEMATICS / PARTLIST.....	98
ANNEX E. DECLARATION OF SIMILARITY.....	99

## 1. Report Revision History

Report No.	Report Version	Description	Issue Date
16071314-FCC-R1	NONE	Original	December 02, 2016
16071314-FCC-R1-V1	V1	Updated the RF Operating frequency	December 14, 2016

## 2. Customer information

Applicant Name	Verykool USA Inc
Applicant Add	3636 Nobel Drive, Suite 325, San Diego, California 92122 United States
Manufacturer	VIKIN COMMUNICATION TECHNOLOGY CO.,LTD
Manufacturer Add	Room 1005, HSAE Technology Building, Hi-Tech Park, Nanshan District, Shenzhen

## 3. Test site information

Lab performing tests	SIEMIC (Shenzhen-China) LABORATORIES
Lab Address	Zone A, Floor 1, Building 2 Wan Ye Long Technology Park South Side of Zhoushi Road, Bao' an District, Shenzhen, Guangdong China 518108
FCC Test Site No.	718246
IC Test Site No.	4842E-1
Test Software	Radiated Emission Program-To Shenzhen v2.0

## 4. Equipment under Test (EUT) Information

Description of EUT:	Mobile Phone
Main Model:	SL5560
Serial Model:	N/A
Date EUT received:	November 15, 2016
Test Date(s):	November 16 to December 01, 2016
Equipment Category :	PCE
Antenna Gain:	GSM850: -1.25dBi PCS1900: 1dBi UMTS-FDD Band V: -1.18dBi UMTS-FDD Band IV: 0.45dBi UMTS-FDD Band II: 1.19dBi LTE Band II: 1.17dBi LTE Band IV: 0.6dBi LTE Band V: -0.65dBi LTE Band VII: -0.72dBi LTE Band XII: -1.3dBi LTE Band XVII: -1.42dBi Bluetooth/BLE: 0.58dBi WIFI: 0.6dBi GPS: 0.71dBi
Antenna Type:	PIFA antenna
Type of Modulation:	GSM / GPRS: GMSK EGPRS: GMSK,8PSK UMTS-FDD: QPSK LTE Band: QPSK, 16QAM 802.11b/g/n: DSSS, OFDM Bluetooth: GFSK, $\pi$ /4DQPSK, 8DPSK BLE: GFSK GPS:BPSK

	GSM850 TX: 824.2 ~ 848.8 MHz; RX: 869.2 ~ 893.8 MHz
	PCS1900 TX: 1850.2 ~ 1909.8 MHz; RX: 1930.2 ~ 1989.8 MHz
	UMTS-FDD Band V TX: 826.4 ~ 846.6 MHz; RX: 871.4 ~ 891.6 MHz
	UMTS-FDD Band IV TX:1712.4 ~ 1752.6 MHz;
	RX : 2112.4 ~ 2152.6 MHz
	UMTS-FDD Band II TX:1852.4 ~ 1907.6 MHz;
	RX: 1932.4 ~ 1987.6 MHz
	LTE Band II TX: 1850.7 ~ 1909.3MHz; RX : 1930.7 ~ 1989.3 MHz
RF Operating Frequency (ies):	LTE Band IV TX: 1710.7 ~ 1754.3 MHz; RX : 2110.7~ 2154.3 MHz
	LTE Band V TX: 824.7~ 848.3 MHz; RX : 869.7 ~ 893.3MHz
	LTE Band VII TX: 2502.5 ~ 2567.5 MHz; RX : 2622.5 ~ 2687.5 MHz
	LTE Band XII TX:699.7 ~ 715.3 MHz; RX : 729.7~ 745.3MHz
	LTE Band XVII TX: 706.5 ~ 713.5 MHz; RX : 736.5 ~ 743.5 MHz
	WIFI: 802.11b/g/n(20M): 2412-2462 MHz
	WIFI: 802.11n(40M): 2422-2452 MHz
	Bluetooth& BLE: 2402-2480 MHz
	GPS: 1575.42 MHz
	GSM Voice:GSM850: 32.25 dBm
	PCS1900: 28.48 dBm
	GPRS:GSM850: 32.23 dBm
	PCS1900: 28.44 dBm
	EGPRS(MCS1):GSM850: 32.23dBm
	PCS1900: 28.44 dBm
	EGPRS(MCS5):GSM850: 29.27 dBm
Maximum Conducted	PCS1900: 26.87 dBm
AV Power to Antenna:	RMC:UMTS-FDD Band V: 22.61 dBm
	UMTS-FDD Band II: 22.88 dBm
	UMTS-FDD Band IV: 22.75 dBm
	HSDPA:UMTS-FDD Band V: 21.68 dBm
	UMTS-FDD Band II: 21.79 dBm
	UMTS-FDD Band IV: 21.81 dBm
	HSUPA:UMTS-FDD Band V: 21.69 dBm
	UMTS-FDD Band II: 21.89 dBm
	UMTS-FDD Band IV: 21.79 dBm

GSM Voce:GSM850: 28.83 dBm / ERP  
                   PCS1900: 29.52 dBm / EIRP  
 GPRS:GSM850: 28.92 dBm / ERP  
                   PCS1900: 29.45 dBm / EIRP  
 EGPRS(MCS5):GSM850: 25.99 dBm / ERP  
                   PCS1900: 27.88 dBm / EIRP  
 RMC:UMTS-FDD Band V: 19.15dBm / ERP  
 ERP/EIRP:          UMTS-FDD Band II: 24.01 dBm / EIRP  
                   UMTS-FDD Band IV: 23.15 dBm / EIRP  
 HSUPA:UMTS-FDD Band V: 18.26 dBm / ERP  
                   UMTS-FDD Band II: 22.81 dBm / EIRP  
                   UMTS-FDD Band IV: 22.27 dBm / EIRP  
 HSDPA:UMTS-FDD Band V: 18.46 dBm / ERP  
                   UMTS-FDD Band II: 22.98 dBm / EIRP  
                   UMTS-FDD Band IV: 22.26 dBm / EIRP

GSM 850: 124CH  
 PCS1900: 299CH  
 UMTS-FDD Band V: 102CH  
 UMTS-FDD Band IV: 202CH  
 UMTS-FDD Band II: 277CH  
 Number of Channels: WIFI :802.11b/g/n(20M): 11CH  
                           WIFI :802.11n(40M): 7CH  
                           Bluetooth: 79CH  
                           BLE: 40CH  
                           GPS:1CH

Port:                  USB Port, Earphone Port

Adapter:  
 Model: TPA-46050150UU  
 Input: AC100-240V~50/60Hz,0.3A  
 Output: DC 5.0V,1500mA  
 Input Power: Battery:  
                   Model: K456  
                   Spec: 3.8V,3000mAh(11.4Wh)  
                   Limited charger voltage: 4.35V



Test Report	16071314-FCC-R1-V1
Page	9 of 99

---

Trade Name : Verykool

GPRS/EGPRS Multi-slot class 8/10/12

FCC ID: WA6SL5560

## 5. Test Summary

The product was tested in accordance with the following specifications.

All testing has been performed according to below product classification:

FCC Rules	Description of Test	Result
§ 1.1307; § 2.1093	RF Exposure (SAR)	Compliance
§2.1046; § 22.913(a); § 24.232(c); § 27.50(c.10) ; § 27.50(d.4)	RF Output Power	Compliance
§ 24.232 (d) ; § 27.50(d)	Peak-Average Ratio	Compliance
§ 2.1049; § 22.905; § 22.917; § 24.238; § 27.53(a.5)	99% & -26 dB Occupied Bandwidth	Compliance
§ 2.1051; § 22.917(a); § 24.238(a); § 27.53(h)	Spurious Emissions at Antenna Terminal	Compliance
§ 2.1053; § 22.917(a); § 24.238(a); § 27.53(h)	Field Strength of Spurious Radiation	Compliance
§ 22.917(a); § 24.238(a); § 27.53(h)	Out of band emission, Band Edge	Compliance
§ 2.1055; § 22.355; § 24.235; § 27.5(h); § 27.54	Frequency stability vs. temperature Frequency stability vs. voltage	Compliance

Note: Testing was performed by configuring EUT to maximum output power status, the declared output power class for different

### Measurement Uncertainty

Emissions		
Test Item	Description	Uncertainty
Band Edge and Radiated Spurious Emissions	Confidence level of approximately 95% (in the case where distributions are normal), with a coverage factor of 2 (for EUTs < 0.5m X 0.5m X 0.5m)	+5.6dB/-4.5dB
-	-	-

## 6. MEASUREMENTS, EXAMINATION AND DERIVED RESULTS

### 6.1 RF Exposure (SAR)

Test Result: Pass

The EUT is a portable device, thus requires SAR evaluation;

Please refer to RF Exposure Evaluation Report: 16071314-FCC-H.

## 6.2 RF Output Power

Temperature	22°C
Relative Humidity	59%
Atmospheric Pressure	1017mbar
Test date :	November 17, 2016
Tested By :	Loren Luo

### Requirement(s):

Spec	Item	Requirement	Applicable
§22.913 (a)	a)	ERP:38.45dBm	<input checked="" type="checkbox"/>
§24.232 (c)	b)	EIRP:33dBm	<input checked="" type="checkbox"/>
§27.50 (c)	c)	EIRP: 30dBm	<input checked="" type="checkbox"/>

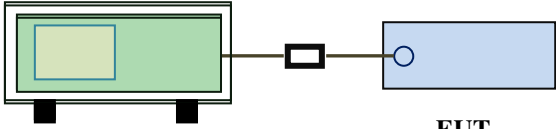
Test Setup	 <p style="text-align: center;">Base Station                      EUT</p>
------------	---

Test Procedure	<p>For Conducted Power:</p> <ul style="list-style-type: none"> <li>- The transmitter output port was connected to base station.</li> <li>- Set EUT at maximum power through base station.</li> <li>- Select lowest, middle, and highest channels for each band and different test mode.</li> </ul> <p>For ERP/EIRP:</p> <p>According with KDB 971168 v02r02</p> <ul style="list-style-type: none"> <li>- The transmitter was placed on a wooden turntable, and it was transmitting into a non-radiating load which was also placed on the turntable.</li> <li>- The measurement antenna was placed at a distance of 3 meters from the EUT. During the tests, the antenna height and polarization as well as EUT azimuth were varied in order to identify the maximum level of emissions from the EUT. The test was performed by placing the EUT on 3-orthogonal axis.</li> <li>- The frequency range up to tenth harmonic of the fundamental</li> </ul>
----------------	---

	<p>frequency was investigated.</p> <ul style="list-style-type: none"> <li>- Remove the EUT and replace it with substitution antenna. A signal generator was connected to the substitution antenna by a non-radiating cable. The absolute levels of the spurious emissions were measured by the substitution.</li> <li>- Spurious emissions in dB = 10 log (TX power in Watts/0.001) – the absolute level</li> <li>- Spurious attenuation limit in dB = 43 + 10 Log10 (power out in Watts).</li> </ul>
Remark	
Result	<input checked="" type="checkbox"/> Pass <input type="checkbox"/> Fail

Test Data     Yes                       N/A

Test Plot     Yes (See below)             N/A

## Conducted Power

### GSM Mode:

Burst Average Power (dBm);								
Band	GSM850				PCS1900			
Channel	128	190	251	Tune up Power tolerant	512	661	810	Tune up Power tolerant
Frequency (MHz)	824.2	836.6	848.8	/	1850.2	1880	1909.8	/
GSM Voice (1 uplink),GMSK	32.14	32.18	<b>32.25</b>	32±1	28.44	<b>28.48</b>	28.39	28±1
GPRS Multi-Slot Class 8 (1 uplink),GMSK	32.13	32.17	<b>32.23</b>	32±1	28.42	<b>28.44</b>	28.38	28±1
GPRS Multi-Slot Class 10 (2 uplink) GMSK	31.27	31.29	31.40	31±1	27.77	27.80	27.75	27.5±1
GPRS Multi-Slot Class 12 (4 uplink) GMSK	28.28	28.34	28.41	28±1	25.01	25.03	25.06	25±1
EGPRS Multi-Slot Class 8 (1 uplink) GMSK MCS1	32.12	32.17	<b>32.23</b>	32±1	28.40	<b>28.42</b>	28.35	28±1
EGPRS Multi-Slot Class 10 (2 uplink) GMSK MCS1	31.25	31.29	31.39	31±1	27.75	27.77	27.74	27.5±1
EGPRS Multi-Slot Class 12 (4 uplink) GMSK MCS1	28.26	28.29	28.39	28±1	25.02	25.02	25.04	25±1
EGPRS Multi-Slot Class 8 (1 uplink) 8PSK MCS5	29.22	29.18	<b>29.27</b>	29±1	26.86	<b>26.87</b>	26.65	26.5±1
EGPRS Multi-Slot Class 10 (2 uplink) 8PSK MCS5	28.25	28.30	28.47	28±1	26.52	26.45	26.12	26±1
EGPRS Multi-Slot Class 12 (4 uplink) 8PSK MCS5	26.57	26.79	26.80	26.5±1	24.24	24.28	24.27	24±1

Test Report	16071314-FCC-R1-V1
Page	15 of 99

Remark :

GPRS, CS1 coding scheme.

EGPRS, MCS1 coding scheme.

EGPRS, MCS5 coding scheme.

Multi-Slot Class 8 , Support Max 4 downlink, 1 uplink , 5 working link

Multi-Slot Class 10 , Support Max 4 downlink, 2 uplink , 5 working link

Multi-Slot Class 12 , Support Max 4 downlink, 4 uplink , 5 working link

## UMTS Mode:

### UMTS-FDD Band V

Band/ Time Slot configuration	Channel	Frequency	Average power (dBm)	Tune up Power tolerant
RMC 12.2kbps	4132	826.4	22.46	22.5±1
	4175	835	22.53	22.5±1
	4233	846.6	<b>22.61</b>	22.5±1
HSDPA Subtest1	4132	826.4	21.50	22±1
	4175	835	21.56	22±1
	4233	846.6	21.58	22±1
HSDPA Subtest2	4132	826.4	21.67	22±1
	4175	835	21.64	22±1
	4233	846.6	<b>21.68</b>	22±1
HSDPA Subtest3	4132	826.4	21.48	22±1
	4175	835	21.43	22±1
	4233	846.6	21.45	22±1
HSDPA Subtest4	4132	826.4	21.56	22±1
	4175	835	21.57	22±1
	4233	846.6	21.59	22±1
HSUPA Subtest1	4132	826.4	21.52	22±1
	4175	835	21.55	22±1
	4233	846.6	21.51	22±1
HSUPA Subtest2	4132	826.4	21.49	22±1
	4175	835	21.50	22±1
	4233	846.6	21.54	22±1
HSUPA Subtest3	4132	826.4	21.67	22±1
	4175	835	21.63	22±1
	4233	846.6	21.64	22±1
HSUPA Subtest4	4132	826.4	21.58	22±1
	4175	835	21.61	22±1
	4233	846.6	21.60	22±1
HSUPA Subtest5	4132	826.4	<b>21.69</b>	22±1
	4175	835	21.65	22±1
	4233	846.6	21.64	22±1



## UMTS-FDD Band II

Band/ Time Slot configuration	Channel	Frequency	Average power (dBm)	Tune up Power tolerant
RMC 12.2kbps	9262	1852.4	<b>22.88</b>	22.5±1
	9400	1880	22.57	22.5±1
	9538	1907.6	22.82	22.5±1
HSDPA Subtest1	9262	1852.4	21.69	22±1
	9400	1880	21.63	22±1
	9538	1907.6	21.64	22±1
HSDPA Subtest2	9262	1852.4	<b>21.79</b>	22±1
	9400	1880	21.75	22±1
	9538	1907.6	21.78	22±1
HSDPA Subtest3	9262	1852.4	21.63	22±1
	9400	1880	21.68	22±1
	9538	1907.6	21.61	22±1
HSDPA Subtest4	9262	1852.4	21.54	22±1
	9400	1880	21.59	22±1
	9538	1907.6	21.56	22±1
HSUPA Subtest1	9262	1852.4	21.83	22±1
	9400	1880	21.85	22±1
	9538	1907.6	<b>21.89</b>	22±1
HSUPA Subtest2	9262	1852.4	21.84	22±1
	9400	1880	21.88	22±1
	9538	1907.6	21.81	22±1
HSUPA Subtest3	9262	1852.4	21.78	22±1
	9400	1880	21.79	22±1
	9538	1907.6	21.85	22±1
HSUPA Subtest4	9262	1852.4	21.87	22±1
	9400	1880	21.83	22±1
	9538	1907.6	21.81	22±1
HSUPA Subtest5	9262	1852.4	21.86	22±1
	9400	1880	21.87	22±1
	9538	1907.6	21.89	22±1

## UMTS-FDD Band IV

Band/ Time Slot configuration	Channel	Frequency	Average power (dBm)	Tune up Power tolerant
RMC 12.2kbps	1313	1712.6	<b>22.75</b>	22.5±1
	1413	1732.6	22.49	22.5±1
	1512	1752.4	22.63	22.5±1
HSDPA Subtest1	1313	1712.6	21.73	22±1
	1413	1732.6	21.75	22±1
	1512	1752.4	21.72	22±1
HSDPA Subtest2	1313	1712.6	21.77	22±1
	1413	1732.6	21.79	22±1
	1512	1752.4	<b>21.81</b>	22±1
HSDPA Subtest3	1313	1712.6	21.78	22±1
	1413	1732.6	21.79	22±1
	1512	1752.4	21.81	22±1
HSDPA Subtest4	1313	1712.6	21.71	22±1
	1413	1732.6	21.69	22±1
	1512	1752.4	21.65	22±1
HSUPA Subtest1	1313	1712.6	<b>21.79</b>	22±1
	1413	1732.6	21.75	22±1
	1512	1752.4	21.73	22±1
HSUPA Subtest2	1313	1712.6	21.70	22±1
	1413	1732.6	21.69	22±1
	1512	1752.4	21.72	22±1
HSUPA Subtest3	1313	1712.6	21.75	22±1
	1413	1732.6	21.78	22±1
	1512	1752.4	21.77	22±1
HSUPA Subtest4	1313	1712.6	21.69	22±1
	1413	1732.6	21.63	22±1
	1512	1752.4	21.65	22±1
HSUPA Subtest5	1313	1712.6	21.74	22±1
	1413	1732.6	21.76	22±1
	1512	1752.4	21.75	22±1

## ERP & EIRP

### GSM Voice

#### ERP for Cellular Band (Part 22H)

Frequency (MHz)	Substituted level (dBm)	Antenna Polarization	Antenna Gain correction (dBi)	Cable Loss (dB)	Absolute Level (dBm)	Limit (dBm)
824.2	22.48	V	6.8	0.53	28.75	38.45
824.2	20.84	H	6.8	0.53	27.11	38.45
836.6	22.56	V	6.8	0.53	<b>28.83</b>	38.45
836.6	20.95	H	6.8	0.53	27.22	38.45
848.8	22.43	V	6.9	0.53	28.80	38.45
848.8	20.79	H	6.9	0.53	27.16	38.45

#### EIRP for PCS Band (Part 24E)

Frequency (MHz)	Substituted level (dBm)	Antenna Polarization	Antenna Gain correction (dBi)	Cable Loss (dB)	Absolute Level (dBm)	Limit (dBm)
1850.2	22.37	V	7.88	0.85	29.40	33
1850.2	20.92	H	7.88	0.85	27.95	33
1880	22.43	V	7.88	0.85	29.46	33
1880	20.97	H	7.88	0.85	28.00	33
1909.8	22.51	V	7.86	0.85	<b>29.52</b>	33
1909.8	21.04	H	7.86	0.85	28.05	33

**GPRS:**

**ERP for Cellular Band (Part 22H)**

Frequency (MHz)	Substituted level (dBm)	Antenna Polarization	Antenna Gain correction (dBi)	Cable Loss (dB)	Absolute Level (dBm)	Limit (dBm)
824.2	22.51	V	6.8	0.53	28.78	38.45
824.2	20.92	H	6.8	0.53	27.19	38.45
836.6	22.46	V	6.8	0.53	28.73	38.45
836.6	20.82	H	6.8	0.53	27.09	38.45
848.8	22.55	V	6.9	0.53	<b>28.92</b>	38.45
848.8	21.03	H	6.9	0.53	27.40	38.45

**EIRP for PCS Band (Part 24E)**

Frequency (MHz)	Substituted level (dBm)	Antenna Polarization	Antenna Gain correction (dBi)	Cable Loss (dB)	Absolute Level (dBm)	Limit (dBm)
1850.2	22.35	V	7.88	0.85	29.38	33
1850.2	20.86	H	7.88	0.85	27.89	33
1880	22.29	V	7.88	0.85	29.32	33
1880	20.75	H	7.88	0.85	27.78	33
1909.8	22.44	V	7.86	0.85	<b>29.45</b>	33
1909.8	20.98	H	7.86	0.85	27.99	33

**EGPRS (MCS5):**

**ERP for Cellular Band (Part 22H)**

Frequency (MHz)	Substituted level (dBm)	Antenna Polarization	Antenna Gain correction (dBi)	Cable Loss (dB)	Absolute Level (dBm)	Limit (dBm)
824.2	19.56	V	6.8	0.53	25.83	38.45
824.2	17.73	H	6.8	0.53	24.00	38.45
836.6	19.47	V	6.8	0.53	25.74	38.45
836.6	17.68	H	6.8	0.53	23.95	38.45
848.8	19.62	V	6.9	0.53	<b>25.99</b>	38.45
848.8	17.76	H	6.9	0.53	24.13	38.45

**EIRP for PCS Band (Part 24E)**

Frequency (MHz)	Substituted level (dBm)	Antenna Polarization	Antenna Gain correction (dBi)	Cable Loss (dB)	Absolute Level (dBm)	Limit (dBm)
1850.2	20.76	V	7.88	0.85	27.79	33
1850.2	19.13	H	7.88	0.85	26.16	33
1880	20.85	V	7.88	0.85	<b>27.88</b>	33
1880	19.24	H	7.88	0.85	26.27	33
1909.8	20.68	V	7.86	0.85	27.69	33
1909.8	18.97	H	7.86	0.85	25.98	33

## RMC

### ERP for UMTS-FDD Band V (Part 22H)

Frequency (MHz)	Substituted level (dBm)	Antenna Polarization	Antenna Gain correction (dBi)	Cable Loss (dB)	Absolute Level (dBm)	Limit (dBm)
826.4	12.84	V	6.8	0.53	19.11	38.45
826.4	12.08	H	6.8	0.53	18.35	38.45
835	12.73	V	6.8	0.53	19.00	38.45
835	11.97	H	6.8	0.53	18.24	38.45
846.6	12.78	V	6.9	0.53	<b>19.15</b>	38.45
846.6	12.02	H	6.9	0.53	18.39	38.45

### EIRP for UMTS-FDD Band II (Part 24E)

Frequency (MHz)	Substituted level (dBm)	Antenna Polarization	Antenna Gain correction (dBi)	Cable Loss (dB)	Absolute Level (dBm)	Limit (dBm)
1852.4	16.98	V	7.88	0.85	<b>24.01</b>	33
1852.4	16.13	H	7.88	0.85	23.16	33
1880	16.76	V	7.88	0.85	23.79	33
1880	15.89	H	7.88	0.85	22.92	33
1907.6	16.84	V	7.86	0.85	23.85	33
1907.6	16.02	H	7.86	0.85	23.03	33

### EIRP for UMTS-FDD Band IV (Part 27H)

Frequency (MHz)	Substituted level (dBm)	Antenna Polarization	Antenna Gain correction (dBi)	Cable Loss (dB)	Absolute Level (dBm)	Limit (dBm)
1712.4	16.21	V	7.76	0.82	<b>23.15</b>	30
1712.4	15.43	H	7.76	0.82	22.37	30
1740	16.17	V	7.76	0.82	23.11	30
1740	15.38	H	7.76	0.82	22.32	30
1752.6	16.02	V	7.74	0.82	22.94	30
1752.6	15.26	H	7.74	0.82	22.18	30

## HSDPA

### ERP for UMTS-FDD Band V (Part 22H)

Frequency (MHz)	Substituted level (dBm)	Antenna Polarization	Antenna Gain correction (dBi)	Cable Loss (dB)	Absolute Level (dBm)	Limit (dBm)
826.4	11.94	V	6.8	0.53	18.21	38.45
826.4	11.23	H	6.8	0.53	17.50	38.45
835	11.86	V	6.8	0.53	18.13	38.45
835	11.12	H	6.8	0.53	17.39	38.45
846.6	11.89	V	6.9	0.53	<b>18.26</b>	38.45
846.6	11.15	H	6.9	0.53	17.52	38.45

### EIRP for UMTS-FDD Band II (Part 24E)

Frequency (MHz)	Substituted level (dBm)	Antenna Polarization	Antenna Gain correction (dBi)	Cable Loss (dB)	Absolute Level (dBm)	Limit (dBm)
1852.4	15.78	V	7.88	0.85	<b>22.81</b>	33
1852.4	14.89	H	7.88	0.85	21.92	33
1880	15.67	V	7.88	0.85	22.70	33
1880	14.81	H	7.88	0.85	21.84	33
1907.6	15.73	V	7.86	0.85	22.74	33
1907.6	14.85	H	7.86	0.85	21.86	33

### EIRP for UMTS-FDD Band IV (Part 27H)

Frequency (MHz)	Substituted level (dBm)	Antenna Polarization	Antenna Gain correction (dBi)	Cable Loss (dB)	Absolute Level (dBm)	Limit (dBm)
1712.4	15.23	V	7.76	0.82	22.17	30
1712.4	14.47	H	7.76	0.82	21.41	30
1740	15.06	V	7.76	0.82	22.00	30
1740	14.26	H	7.76	0.82	21.20	30
1752.6	15.35	V	7.74	0.82	<b>22.27</b>	30
1752.6	14.57	H	7.74	0.82	21.49	30

## HSUPA

### ERP for UMTS-FDD Band V (Part 22H)

Frequency (MHz)	Substituted level (dBm)	Antenna Polarization	Antenna Gain correction (dBi)	Cable Loss (dB)	Absolute Level (dBm)	Limit (dBm)
826.4	12.05	V	6.8	0.53	18.32	38.45
826.4	11.31	H	6.8	0.53	17.58	38.45
835	12.19	V	6.8	0.53	<b>18.46</b>	38.45
835	11.42	H	6.8	0.53	17.69	38.45
846.6	11.95	V	6.9	0.53	18.32	38.45
846.6	11.28	H	6.9	0.53	17.65	38.45

### EIRP for UMTS-FDD Band II (Part 24E)

Frequency (MHz)	Substituted level (dBm)	Antenna Polarization	Antenna Gain correction (dBi)	Cable Loss (dB)	Absolute Level (dBm)	Limit (dBm)
1852.4	15.95	V	7.88	0.85	<b>22.98</b>	33
1852.4	15.18	H	7.88	0.85	22.21	33
1880	15.84	V	7.88	0.85	22.87	33
1880	15.06	H	7.88	0.85	22.09	33
1907.6	15.86	V	7.86	0.85	22.87	33
1907.6	15.08	H	7.86	0.85	22.09	33

### EIRP for UMTS-FDD Band IV (Part 27H)

Frequency (MHz)	Substituted level (dBm)	Antenna Polarization	Antenna Gain correction (dBi)	Cable Loss (dB)	Absolute Level (dBm)	Limit (dBm)
1712.4	15.32	V	7.76	0.82	<b>22.26</b>	30
1712.4	14.56	H	7.76	0.82	21.50	30
1740	15.25	V	7.76	0.82	22.19	30
1740	14.43	H	7.76	0.82	21.37	30
1752.6	15.12	V	7.74	0.82	22.04	30
1752.6	14.31	H	7.74	0.82	21.23	30



### 6.3 Peak-Average Ratio

Temperature	22°C
Relative Humidity	59%
Atmospheric Pressure	1017mbar
Test date :	November 17, 2016
Tested By :	Loren Luo

Requirement(s):

Spec	Item	Requirement	Applicable
§24.232(d) § 27.50(d)	a)	The peak-to-average ratio (PAR) of the transmission may not exceed 13 dB.	<input checked="" type="checkbox"/>

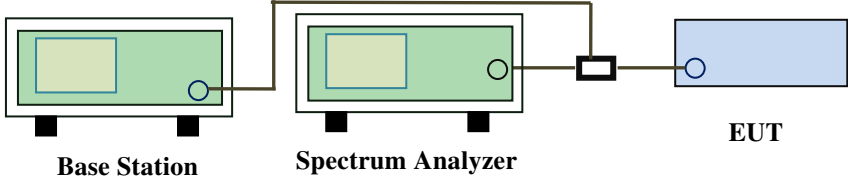
Test Setup	 <p>The diagram illustrates the test setup. On the left is a 'Base Station' (green box). A cable connects it to a 'Spectrum Analyzer' (green box). Another cable connects the Spectrum Analyzer to the 'EUT' (blue box). A small black box is positioned between the Spectrum Analyzer and the EUT, likely representing a coupler or filter.</p>
------------	---

Test Procedure	<p><b>According with KDB 971168 v02r02</b></p> <p><b>5.7.2 Alternate procedure for PAPR</b></p> <p><b>5.1.2 Peak power measurements with a peak power meter</b></p> <p>The total peak output power may be measured using a broadband peak RF power meter. The power meter must have a video bandwidth that is greater than or equal to the emission bandwidth and utilize a fast-responding diode detector.</p> <p><b>5.2.3 Average power measurement with average power meter</b></p> <p>As an alternative to the use of a spectrum/signal analyzer or EMI receiver to perform a measurement of the total in-band average output power, a wideband RF average power meter with a thermocouple detector or equivalent can be used under certain conditions</p> <p>If the EUT can be configured to transmit continuously (i.e., the burst duty cycle <math>\geq 98\%</math>) and at all times the EUT is transmitting at its maximum output</p>
----------------	--

Test Report	16071314-FCC-R1-V1
Page	26 of 99

	<p>power level, then a conventional wide-band RF power meter can be used.</p> <p>If the EUT cannot be configured to transmit continuously (i.e., the burst duty cycle &lt; 98%), then there are two options for the use of an average power meter. First, a gated average power meter can be used to perform the measurement if the gating parameters can be adjusted such that the power is measured only over active transmission bursts at maximum output power levels. A conventional average power meter can also be used if the measured burst duty cycle is constant (i.e., duty cycle variations are less than <math>\pm 2</math> percent) by performing the measurement over the on/off burst cycles and then correcting (increasing) the measured level by a factor equal to <math>10\log(1/\text{duty cycle})</math></p>
Remark	
Result	<input checked="" type="checkbox"/> Pass <input type="checkbox"/> Fail

**Test Data**     Yes                       N/A  
**Test Plot**     Yes (See below)             N/A

**GSM : GSM 1900 PK-AV POWER (PART 24E)**

Frequency (MHz)	Conducted power(dBm)		Peak-Average Ratio(PAR)
	Peak	Average	
1850.2	29.68	28.44	1.24
1880	29.54	28.48	1.06
1909.8	29.83	28.39	1.44

**GPRS 1900 PK-AV POWER (PART 24E)**

Frequency (MHz)	Conducted power(dBm)		Peak-Average Ratio(PAR)
	Peak	Average	
1850.2	29.88	28.42	1.46
1880	29.83	28.44	1.39
1909.8	29.79	28.38	1.41

**EGPRS (MSC5) 1900 PK-AV POWER (PART 24E)**

Frequency (MHz)	Conducted power(dBm)		Peak-Average Ratio(PAR)
	Peak	Average	
1850.2	28.53	26.86	1.67
1880	28.44	26.87	1.57
1909.8	28.62	26.65	1.97

**RMC : UMTS-FDD Band II PK-AV POWER (PART 24E)**

Frequency (MHz)	Conducted power(dBm)		Peak-Average Ratio(PAR)
	Peak	Average	
1852.4	25.01	22.88	2.13
1880	25.17	22.57	2.60
1907.6	25.02	22.82	2.20

**UMTS-FDD Band IV PK-AV POWER (PART 24E)**

Frequency (MHz)	Conducted power(dBm)		Peak-Average Ratio(PAR)
	Peak	Average	
1712.4	24.83	22.75	2.08
1740	24.67	22.49	2.18
1752.6	24.79	22.63	2.16

**HSUPA : UMTS-FDD Band II PK-AV POWER (PART 24E)**

Frequency (MHz)	Conducted power(dBm)		Peak-Average Ratio(PAR)
	Peak	Average	
1852.4	23.95	21.83	2.12
1880	23.97	21.85	2.12
1907.6	23.86	21.89	1.97

**UMTS-FDD Band IV PK-AV POWER (PART 24E)**

Frequency (MHz)	Conducted power(dBm)		Peak-Average Ratio(PAR)
	Peak	Average	
1712.4	23.04	21.79	1.25
1740	23.08	21.75	1.33
1752.6	23.02	21.73	1.29

**HSDPA : UMTS-FDD Band II PK-AV POWER (PART 24E)**

Frequency (MHz)	Conducted power(dBm)		Peak-Average Ratio(PAR)
	Peak	Average	
1852.4	23.96	21.69	2.27
1880	23.88	21.63	2.25
1907.6	23.89	21.64	2.25

**UMTS-FDD Band IV PK-AV POWER (PART 24E)**

Frequency (MHz)	Conducted power(dBm)		Peak-Average Ratio(PAR)
	Peak	Average	
1712.4	22.78	21.73	1.05
1740	22.95	21.75	1.2
1752.6	22.76	21.72	1.04

## 6.4 Occupied Bandwidth

Temperature	25°C
Relative Humidity	58%
Atmospheric Pressure	1016mbar
Test date :	November 16&17, 2016
Tested By :	Loren Luo

### Requirement(s):

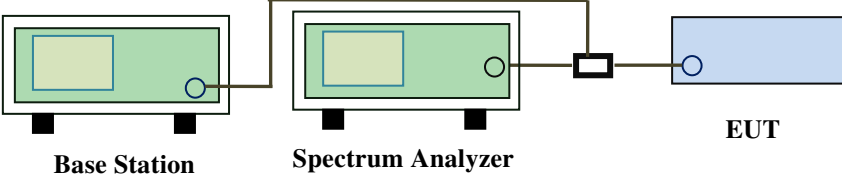
Spec	Item	Requirement	Applicable
§2.1049, §22.917, §22.905 §24.238 §27.53(a)	a)	99% Occupied Bandwidth(kHz)	<input checked="" type="checkbox"/>
	b)	26 dB Bandwidth(kHz)	<input checked="" type="checkbox"/>
Test Setup	 <p style="text-align: center;">Base Station      Spectrum Analyzer      EUT</p>		
Test Procedure	<ul style="list-style-type: none"> <li>- The EUT was connected to Spectrum Analyzer and Base Station via power divider.</li> <li>- The 99% and 26 dB occupied bandwidth (BW) of the middle channel for the highest RF powers.</li> </ul>		
Remark			
Result	<input checked="" type="checkbox"/> Pass <input type="checkbox"/> Fail		

Test Data     Yes       N/A

Test Plot     Yes (See below)       N/A

**GSM Voice:**

**Cellular Band (Part 22H) result**

Channel	Frequency (MHz)	99% Occupied Bandwidth (kHz)	26 dB Bandwidth (kHz)
128	824.2	244.66	316.5
190	836.6	245.25	315.6
251	848.8	247.84	316.7

**PCS Band (Part 24E) result**

Channel	Frequency (MHz)	99% Occupied Bandwidth (kHz)	26 dB Bandwidth (kHz)
512	1850.2	244.83	320.1
661	1880.0	246.47	318.2
810	1909.8	246.02	318.6

**GPRS:**

**Cellular Band (Part 22H) result**

Channel	Frequency (MHz)	99% Occupied Bandwidth (kHz)	26 dB Bandwidth (kHz)
128	824.2	246.40	316.4
190	836.6	247.30	315.7
251	848.8	245.43	315.8

**PCS Band (Part 24E) result**

Channel	Frequency (MHz)	99% Occupied Bandwidth (kHz)	26 dB Bandwidth (kHz)
512	1850.2	244.97	317.7
661	1880.0	243.90	318.6
810	1909.8	245.79	320.5

**EGPRS (MCS 5):**

**Cellular Band (Part 22H) result**

Channel	Frequency (MHz)	99% Occupied Bandwidth (kHz)	26 dB Bandwidth (kHz)
128	824.2	245.12	315.7
190	836.6	246.15	318.2
251	848.8	244.33	316.3

**PCS Band (Part 24E) result**

Channel	Frequency (MHz)	99% Occupied Bandwidth (kHz)	26 dB Bandwidth (kHz)
512	1850.2	243.69	319.0
661	1880.0	245.53	317.1
810	1909.8	246.36	317.8



**RMC:**

**UMTS-FDD Band V (Part 22H)**

Channel	Frequency (MHz)	99% Occupied Bandwidth (MHz)	26 dB Bandwidth (MHz)
4132	826.4	4.2087	4.836
4175	835.0	4.2232	4.851
4233	846.6	4.2070	4.836

**UMTS-FDD Band II (Part 24E)**

Channel	Frequency (MHz)	99% Occupied Bandwidth (MHz)	26 dB Bandwidth (MHz)
9262	1852.4	4.1964	4.871
9400	1880.0	4.2106	4.821
9538	1907.6	4.2065	4.803

**UMTS-FDD Band IV (Part 27)**

Channel	Frequency (MHz)	99% Occupied Bandwidth (MHz)	26 dB Bandwidth (MHz)
1313	1712.6	4.1980	4.851
1413	1732.6	4.2013	4.810
1512	1752.4	4.2011	4.812

**HSUPA:**

**UMTS-FDD Band V (Part 22H)**

Channel	Frequency (MHz)	99% Occupied Bandwidth (MHz)	26 dB Bandwidth (MHz)
4132	826.4	4.2071	4.824
4175	835.0	4.2190	4.841
4233	846.6	4.2113	4.858

**UMTS-FDD Band II (Part 24E)**

Channel	Frequency (MHz)	99% Occupied Bandwidth (MHz)	26 dB Bandwidth (MHz)
9262	1852.4	4.1995	4.816
9400	1880.0	4.2161	4.864
9538	1907.6	4.2170	4.833

**UMTS-FDD Band IV (Part 27)**

Channel	Frequency (MHz)	99% Occupied Bandwidth (MHz)	26 dB Bandwidth (MHz)
1313	1712.6	4.2071	4.851
1413	1732.6	4.2159	4.864
1512	1752.4	4.2009	4.811

**HSDPA:**

**UMTS-FDD Band V (Part 22H)**

Channel	Frequency (MHz)	99% Occupied Bandwidth (MHz)	26 dB Bandwidth (MHz)
4132	826.4	4.2137	4.829
4175	835.0	4.2110	4.847
4233	846.6	4.2089	4.831

**UMTS-FDD Band II (Part 24E)**

Channel	Frequency (MHz)	99% Occupied Bandwidth (MHz)	26 dB Bandwidth (MHz)
9262	1852.4	4.1979	4.844
9400	1880.0	4.2148	4.846
9538	1907.6	4.2030	4.823

**UMTS-FDD Band IV (Part 27)**

Channel	Frequency (MHz)	99% Occupied Bandwidth (MHz)	26 dB Bandwidth (MHz)
1313	1712.6	4.2100	4.819
1413	1732.6	4.2147	4.854
1512	1752.4	4.2122	4.834

**Test Plots**

**GMS Voice:**

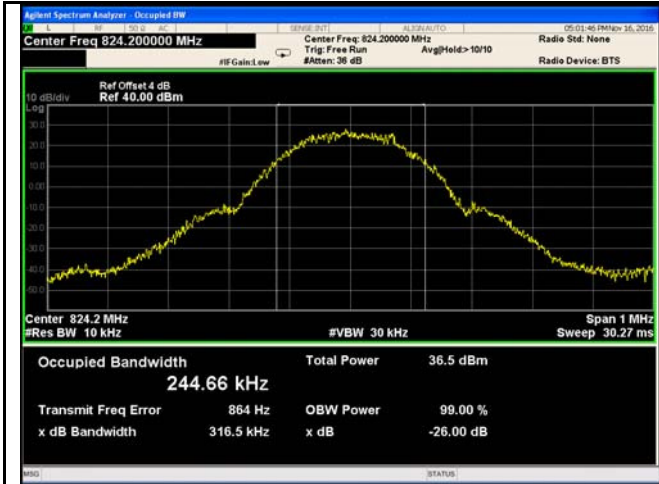

GSM 850 BW - Low CH 824.2MHz

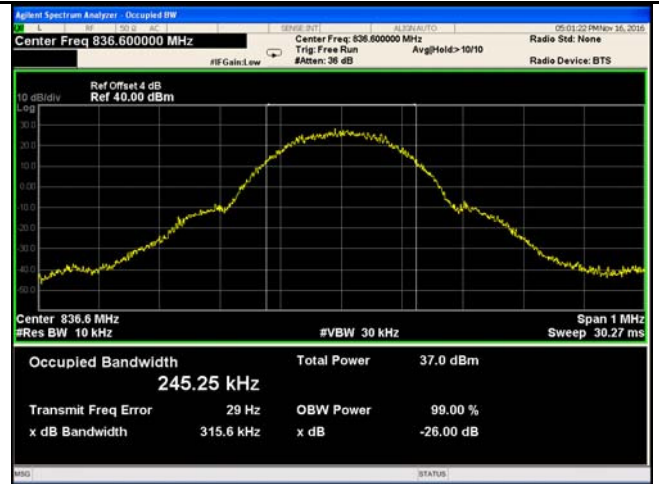

GSM 850 BW - Mid CH 836.6MHz



GSM 850 BW - High CH 848.8MHz

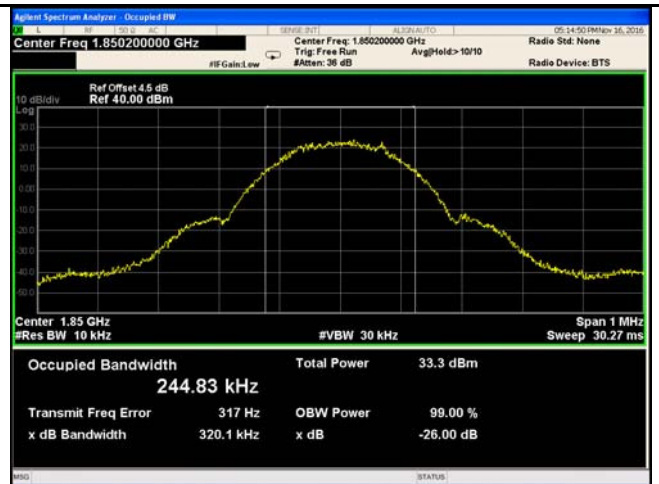

PCS 1900 BW - Low CH 1850.2MHz

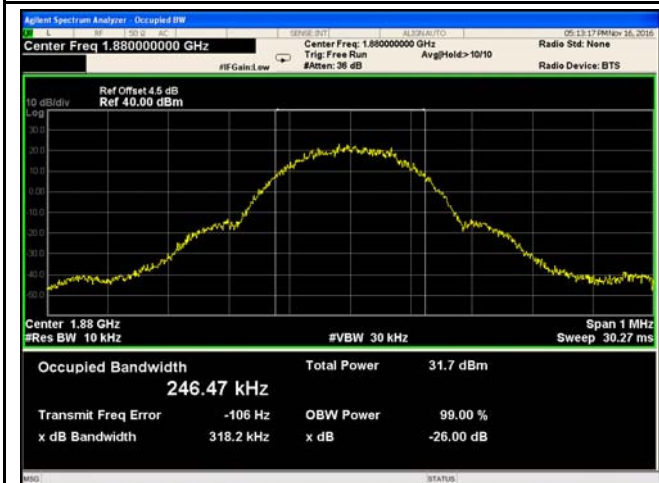

PCS 1900 BW - Mid CH 1880MHz

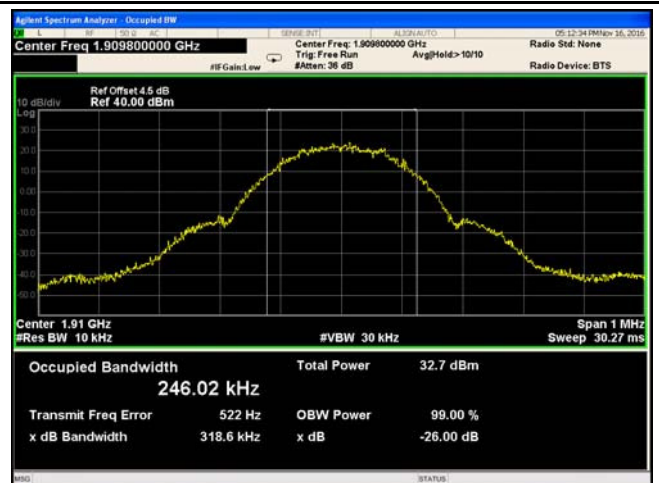

PCS 1900 BW - High CH 1909.8MHz

**GPRS:**

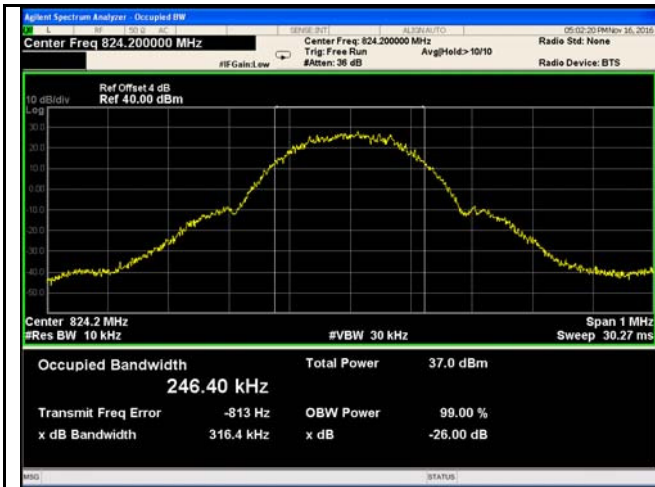

GSM 850 BW - Low CH 824.2MHz

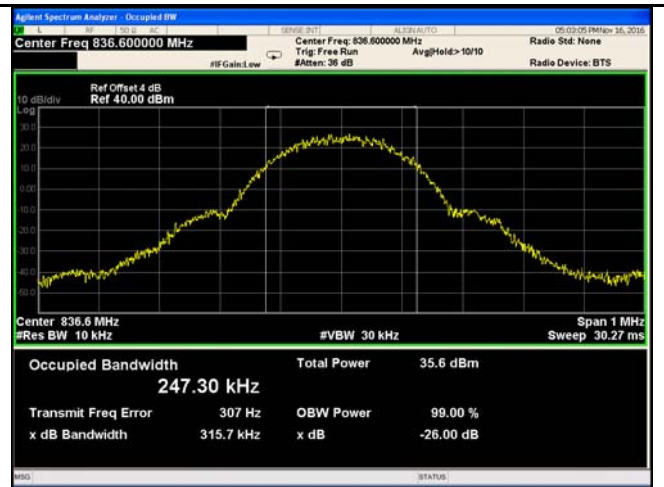

GSM 850 BW - Mid CH 836.6MHz

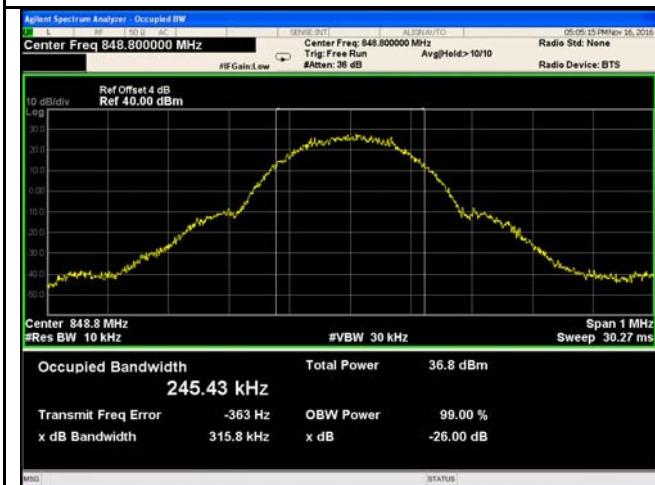

GSM 850 BW - High CH 848.8MHz

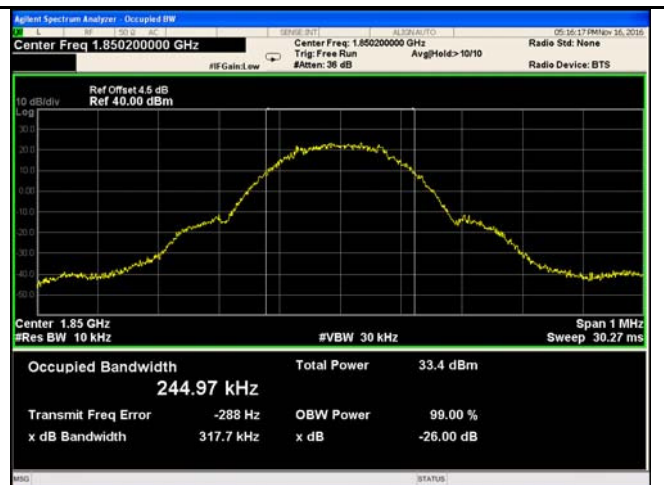

PCS 1900 BW - Low CH 1850.2MHz

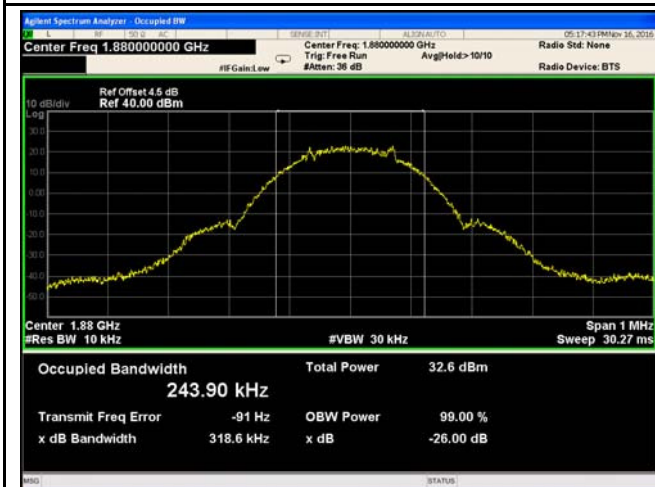

PCS 1900 BW - Mid CH 1880MHz

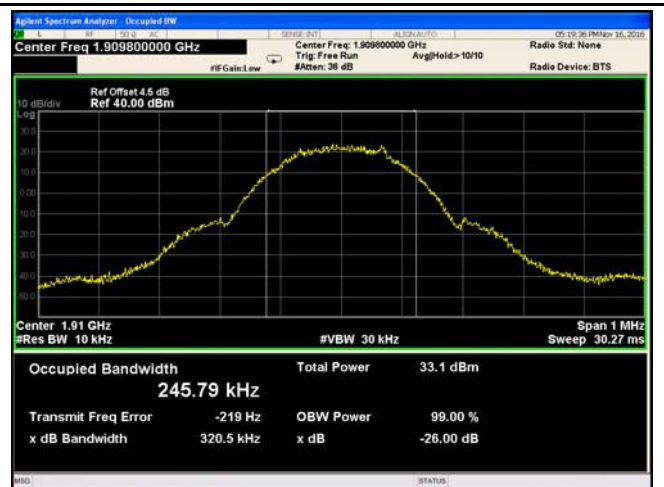

PCS 1900 BW - High CH 1909.8MHz

**EGPRS:**

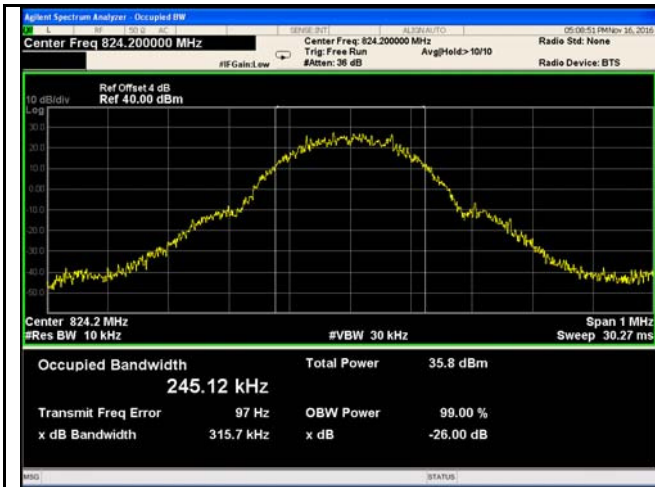

GSM 850 BW - Low CH 824.2MHz

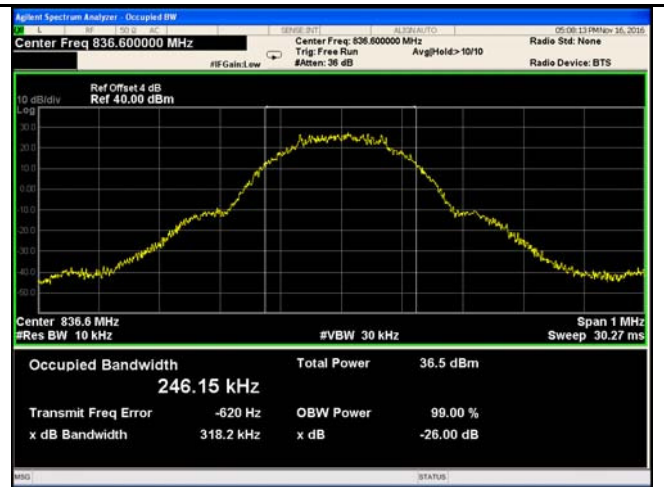

GSM 850 BW - Mid CH 836.6MHz

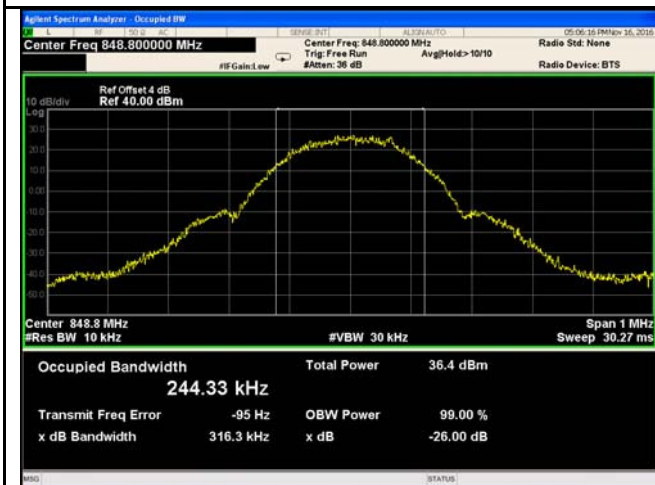

GSM 850 BW - High CH 848.8MHz

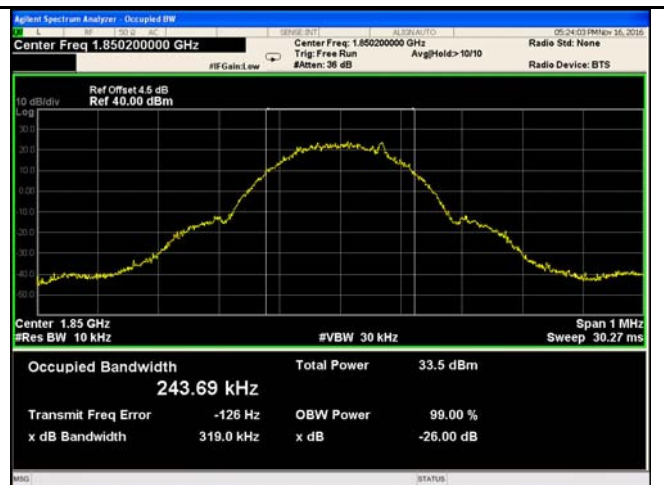

PCS 1900 BW - Low CH 1850.2MHz

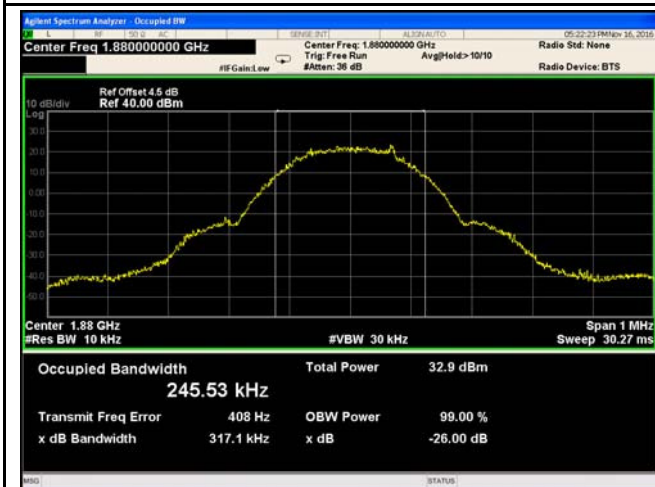

PCS 1900 BW - Mid CH 1880MHz

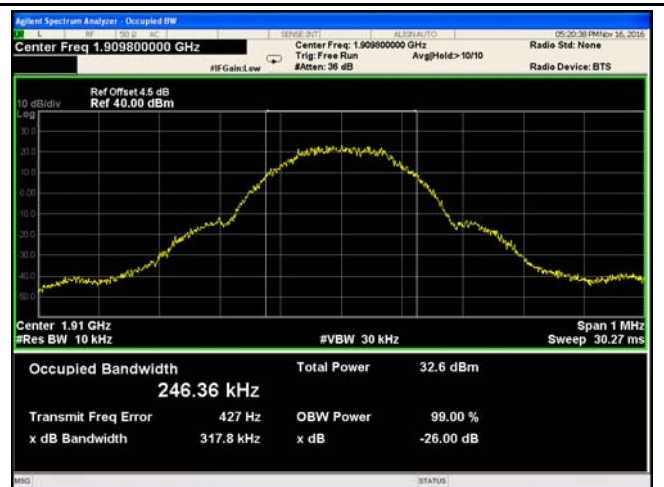

PCS 1900 BW - High CH 1909.8MHz

RMC:

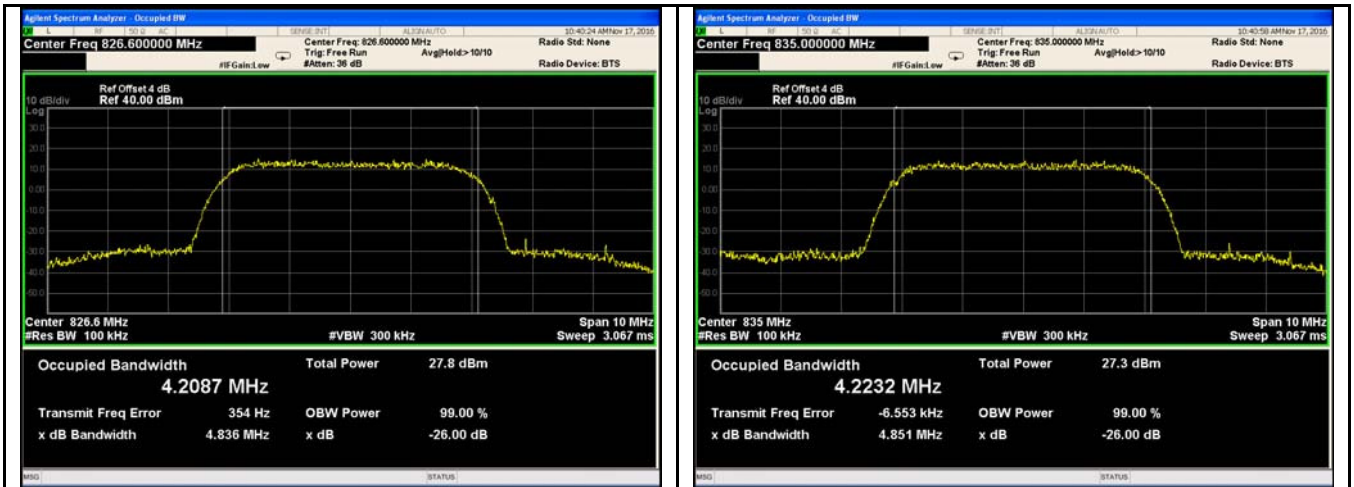

Band V BW - Low CH 826.6 MHz

Band V BW - Mid CH 835.0 MHz

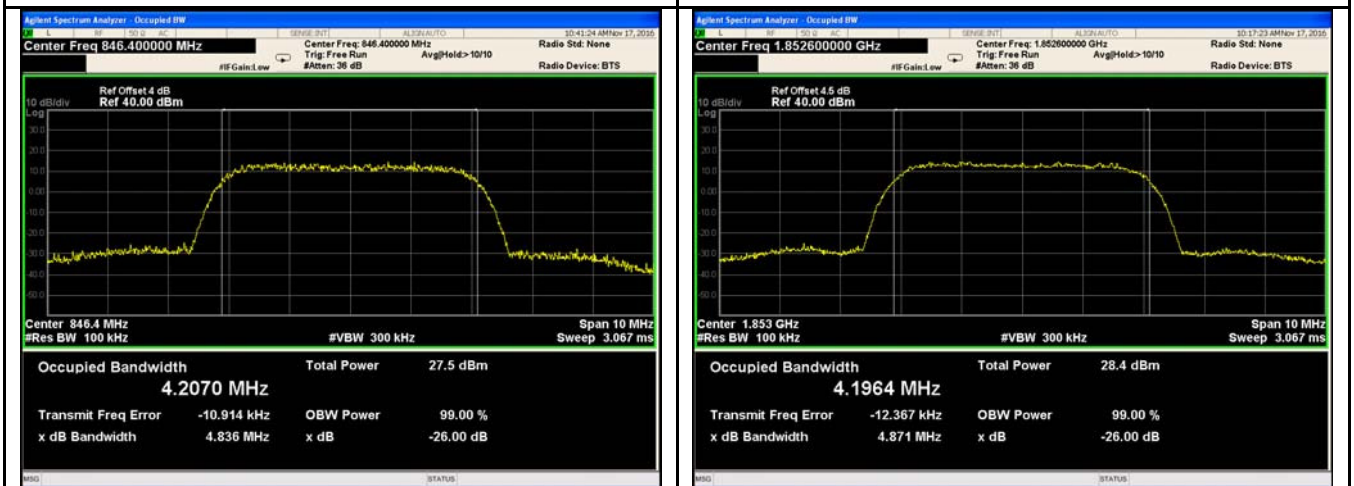

Band V BW - High CH 846.4 MHz

Band II BW - Low CH 1852.4MHz

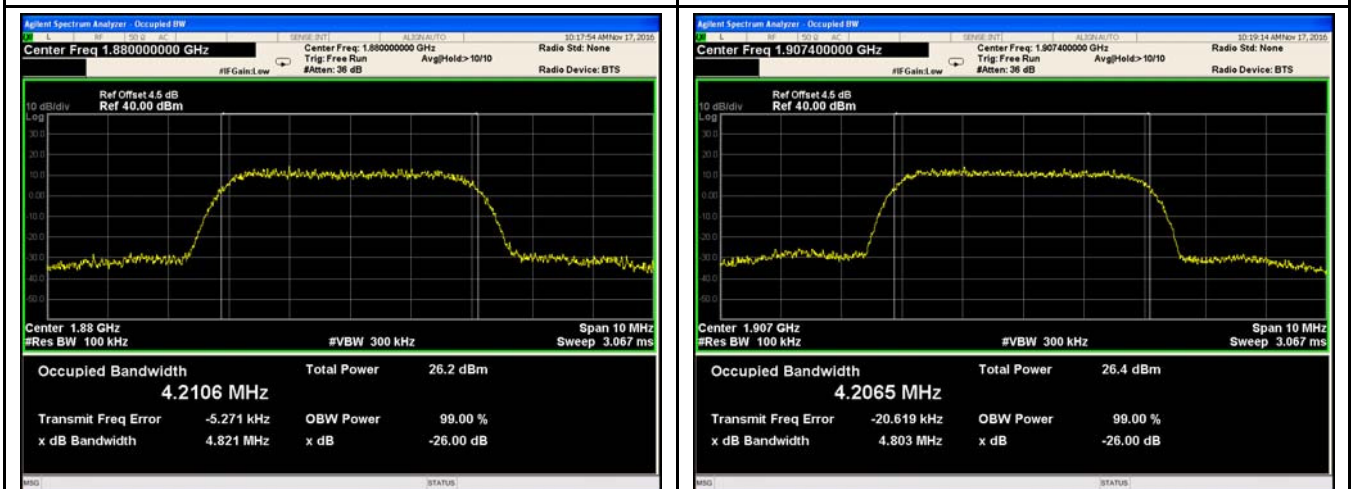

Band II BW - Mid CH 1880MHz

Band II BW - High CH 1907.6MHz

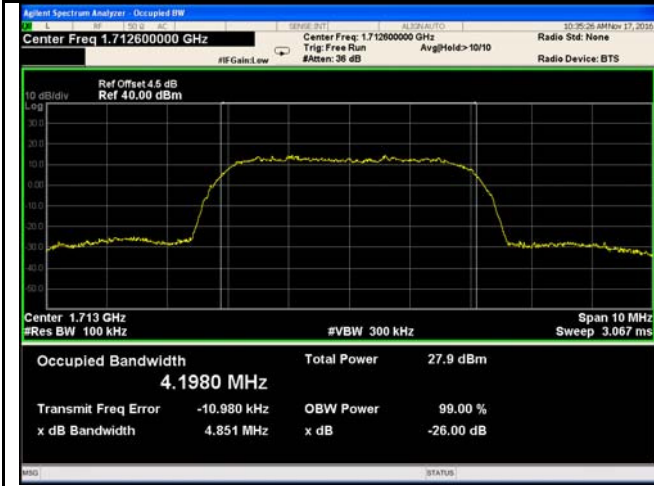

Band IV BW - Low CH 1852.4MHz

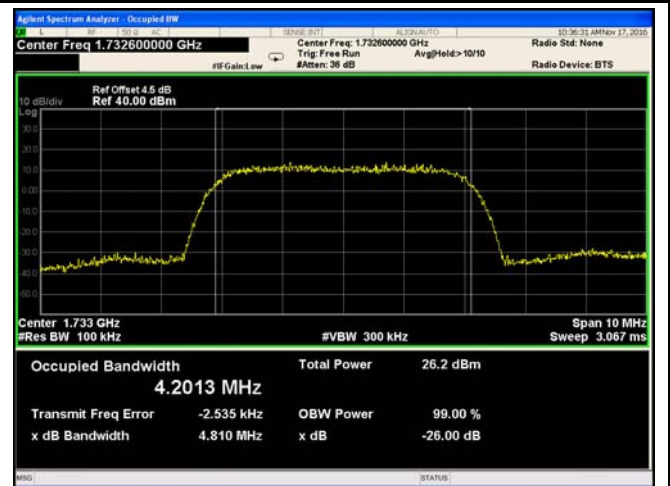

Band IV BW - Mid CH 1880MHz

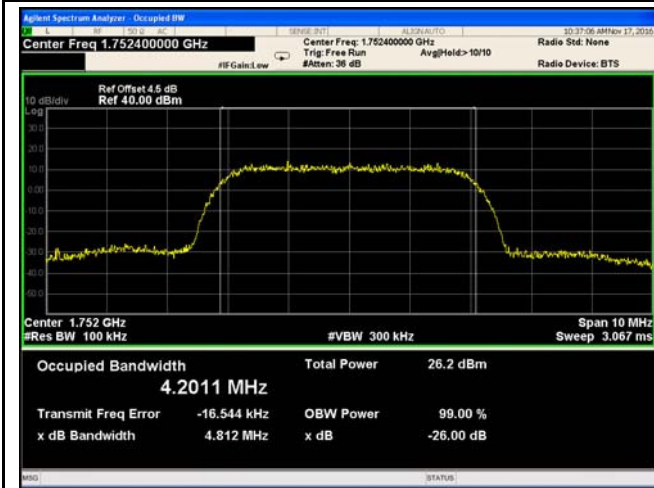

Band IV BW - High CH 1907.6MHz



HSUPA:

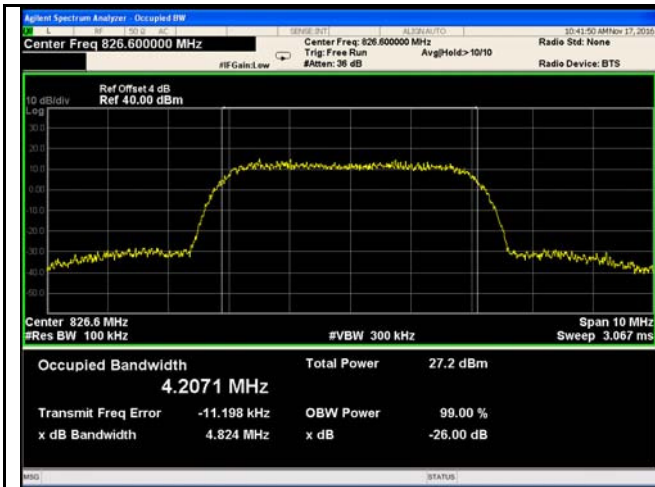

Band V BW - Low CH 826.6 MHz

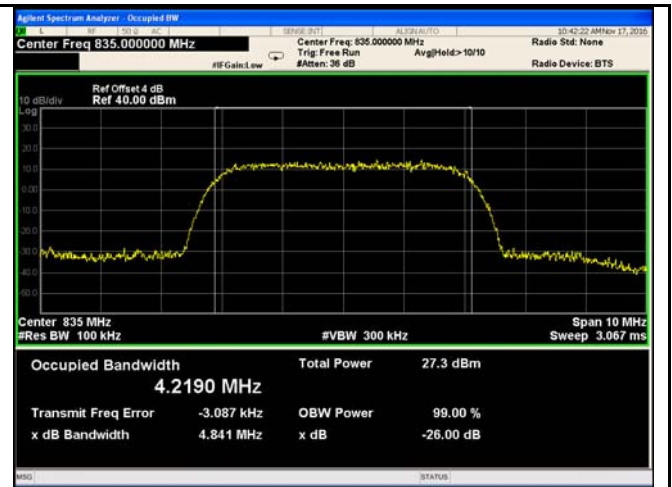

Band V BW - Mid CH 835.0 MHz

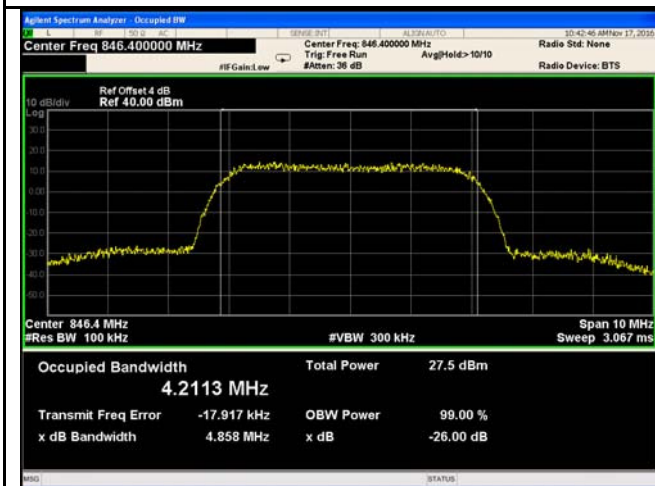

Band V BW - High CH 846.4 MHz

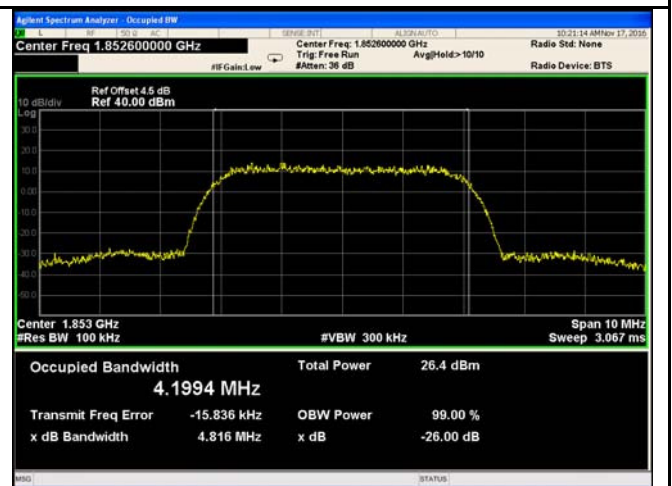

Band II BW - Low CH 1852.4MHz

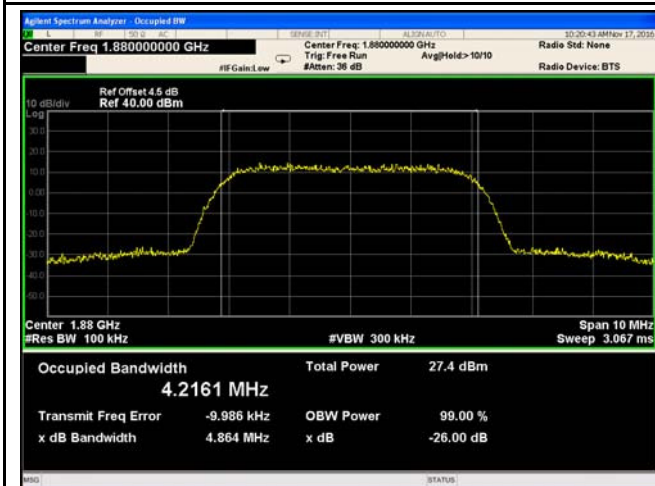

Band II BW - Mid CH 1880MHz

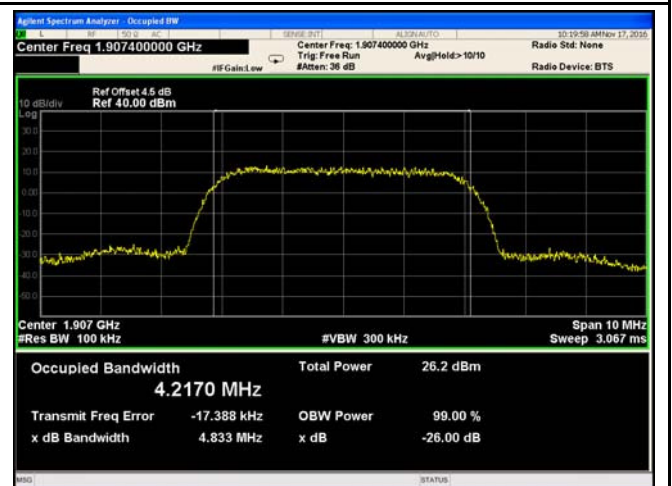

Band II BW - High CH 1907.6MHz

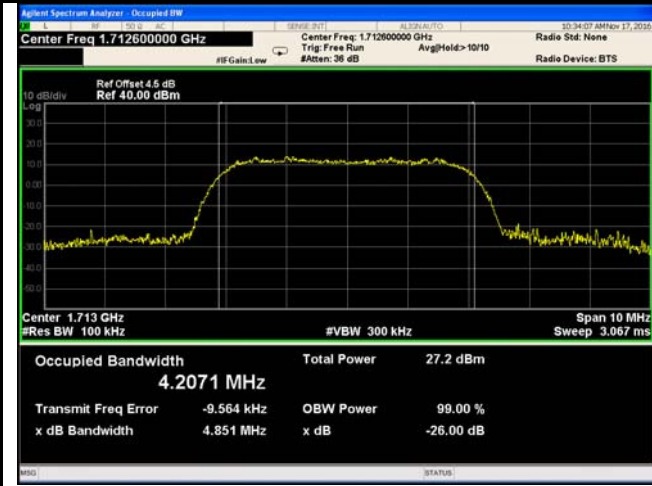

Band IV BW - Low CH 1713MHz

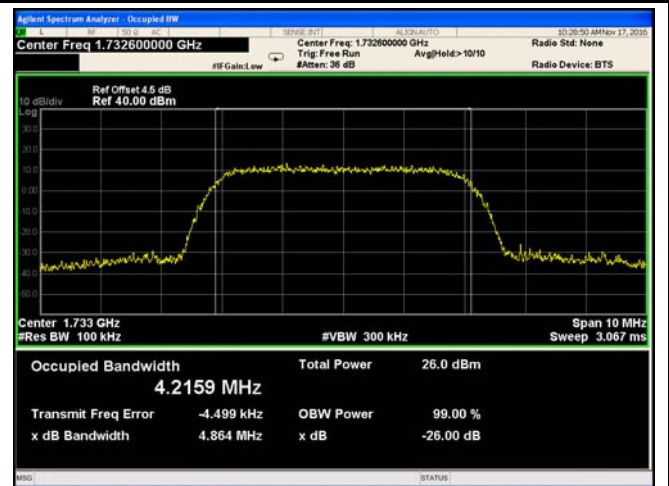

Band IVBW - Mid CH 1733MHz

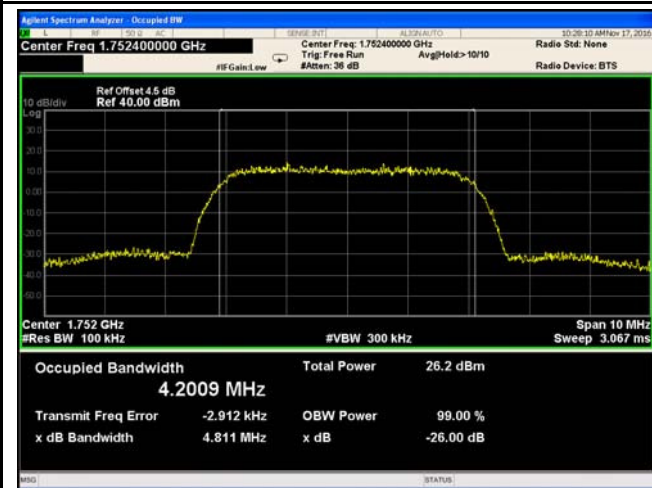

Band IV BW - High CH 1752MHz

HSDPA:

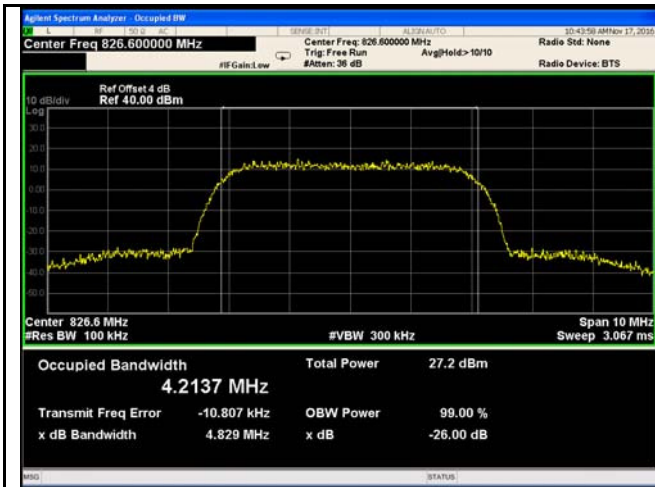

Band V BW - Low CH 826.6 MHz

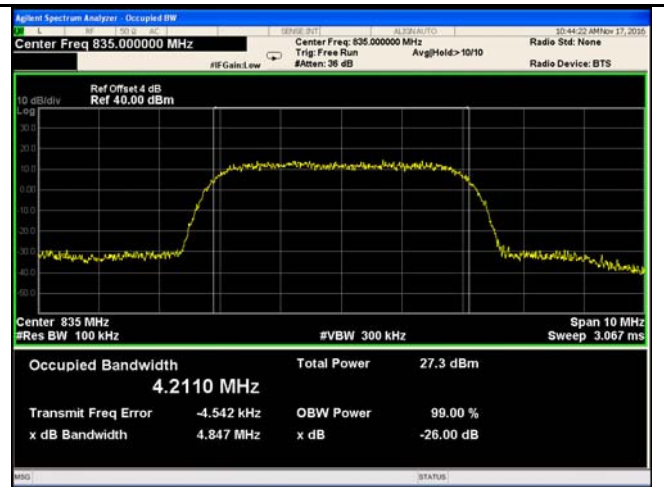

Band V BW - Mid CH 835.0 MHz

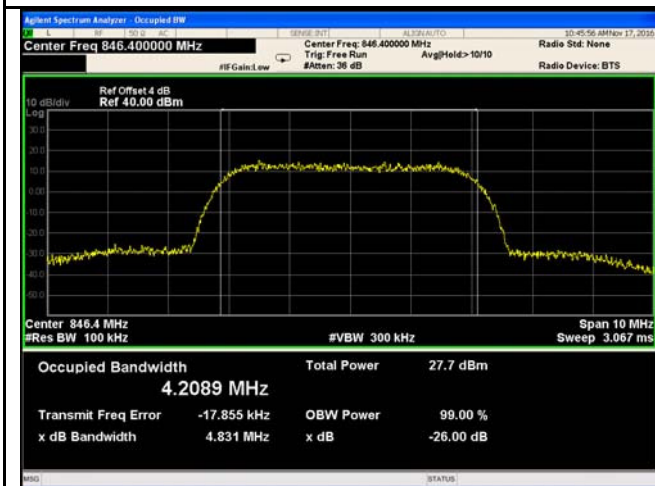

Band V BW - High CH 846.4 MHz

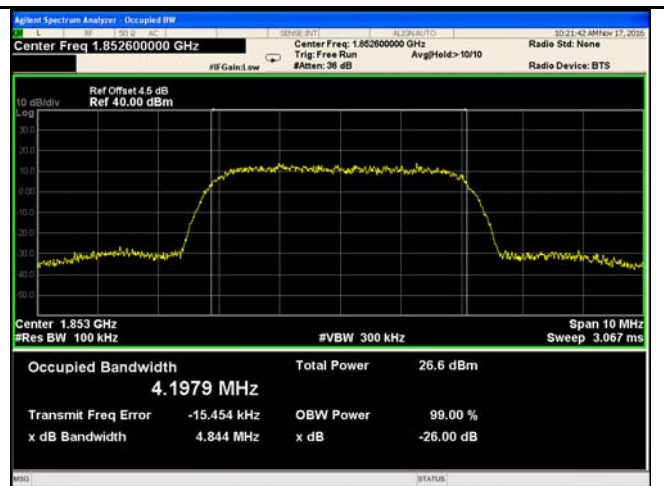

Band II BW - Low CH 1852.4MHz

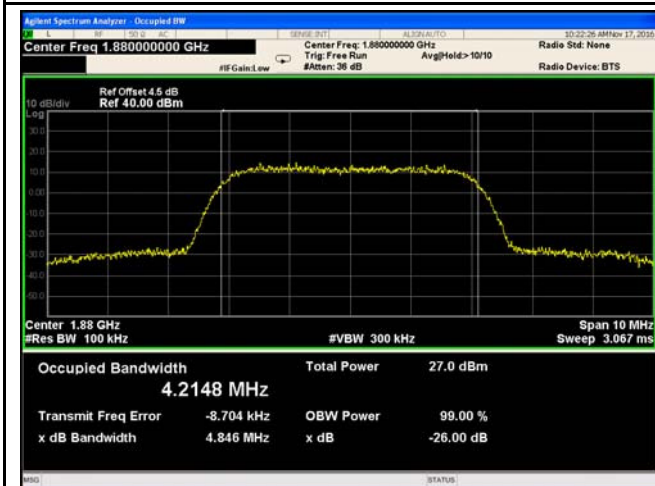

Band II BW - Mid CH 1880MHz

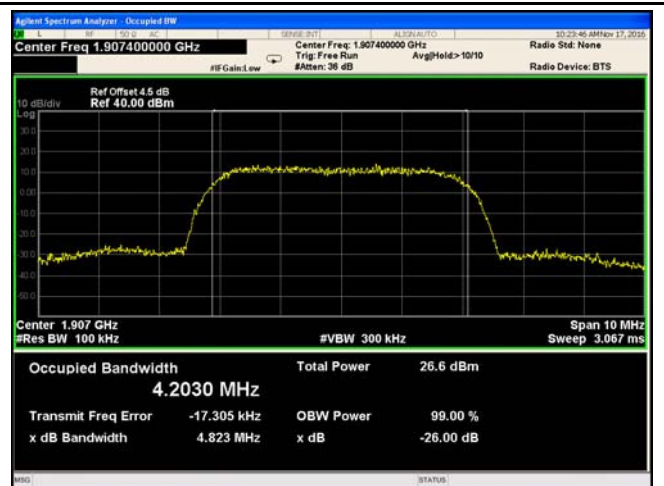

Band II BW - High CH 1907.6MHz

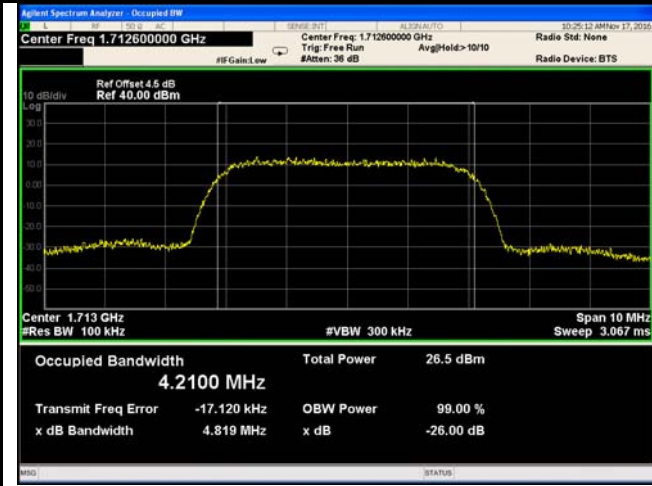

Band IV BW - Low CH 1713MHz

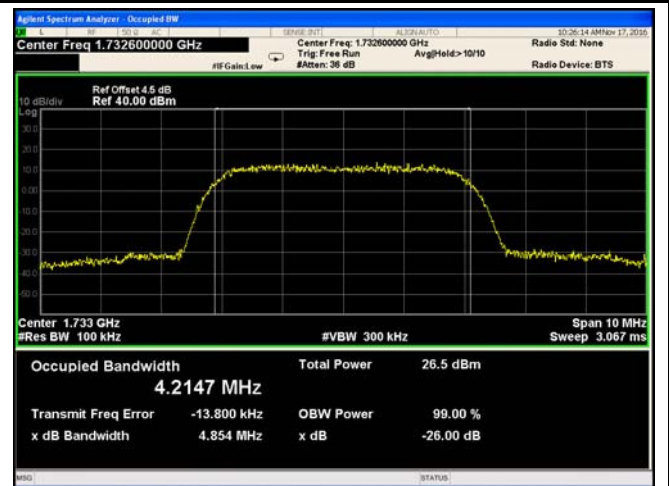

Band IVBW - Mid CH 1733MHz

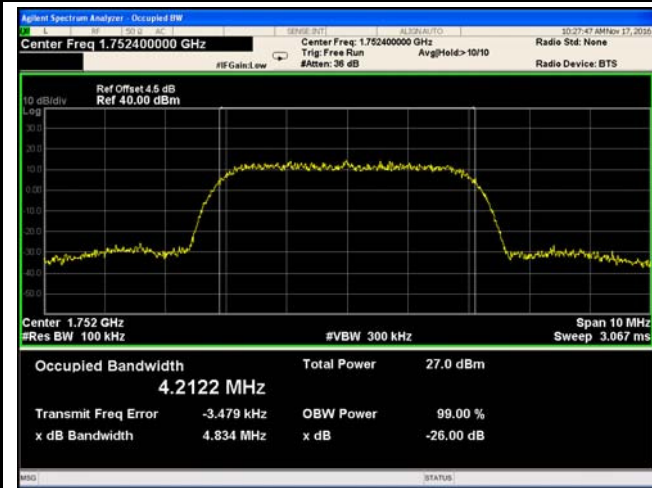

Band IV BW - High CH 1752MHz

## 6.5 Spurious Emissions at Antenna Terminals

Temperature	25°C
Relative Humidity	58%
Atmospheric Pressure	1016mbar
Test date :	November 16&17, 2016
Tested By :	Loren Luo

### Requirement(s):

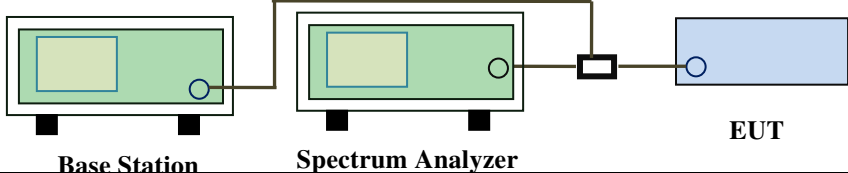
Spec	Item	Requirement	Applicable
§2.1051, §22.917(a)& §24.238(a) § 27.53(h)	a)	The power of any emission outside of the authorized operating frequency ranges must be lower than the transmitter power (P) by a factor of at least $43 + 10 \log(P)$ dB	<input checked="" type="checkbox"/>
Test Setup	 <p style="text-align: center;"> <span style="margin-right: 100px;">Base Station</span> <span style="margin-right: 100px;">Spectrum Analyzer</span> <span>EUT</span> </p>		
Test Procedure	<ul style="list-style-type: none"> <li>- The EUT was connected to Spectrum Analyzer and Base Station via power divider.</li> <li>- The Band Edges of low and high channels for the highest RF powers were measured.</li> <li>- Setting RBW as roughly BW/100.</li> </ul>		
Remark			
Result	<input checked="" type="checkbox"/> Pass <input type="checkbox"/> Fail		

Test Data     Yes                       N/A  
 Test Plot     Yes (See below)         N/A

**Test Plots**

**GSM Voice:**

**Cellular Band (Part 22H) result**

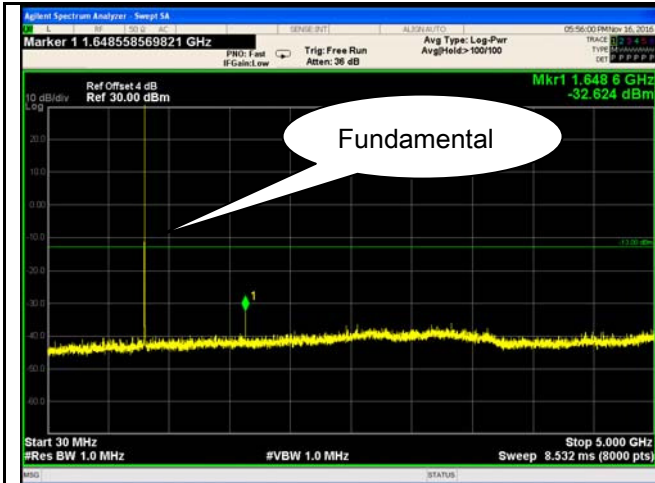

GSM 850 - Low Channel-1

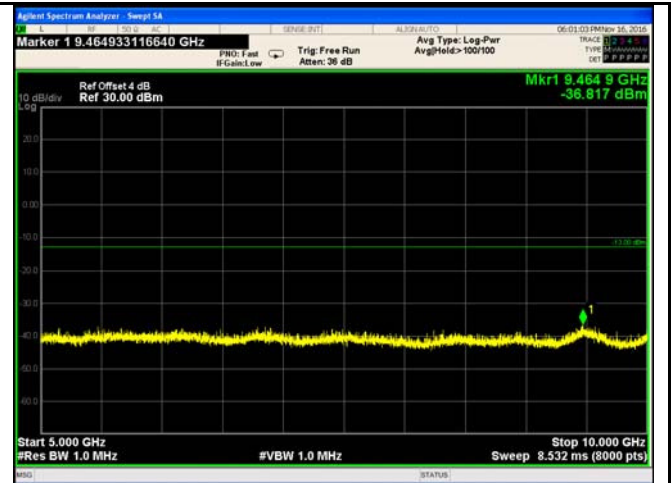

GSM 850 - Low Channel-2

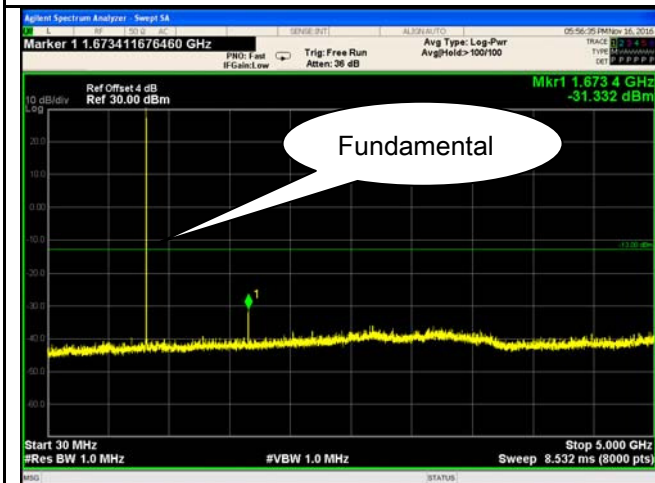

GSM 850 Middle Channel-1

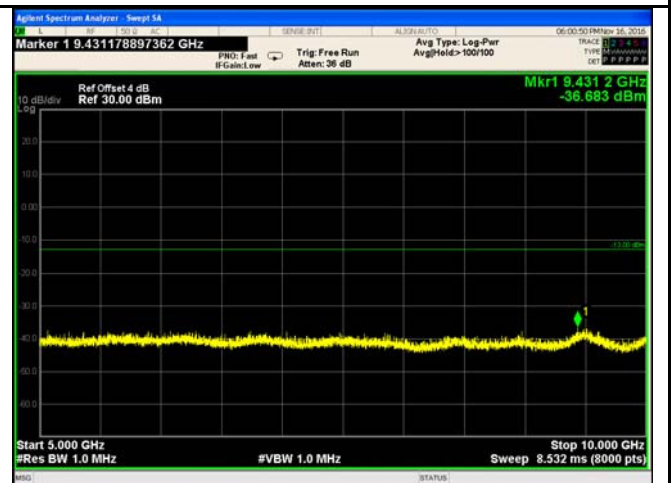

GSM 850 Middle Channel-2

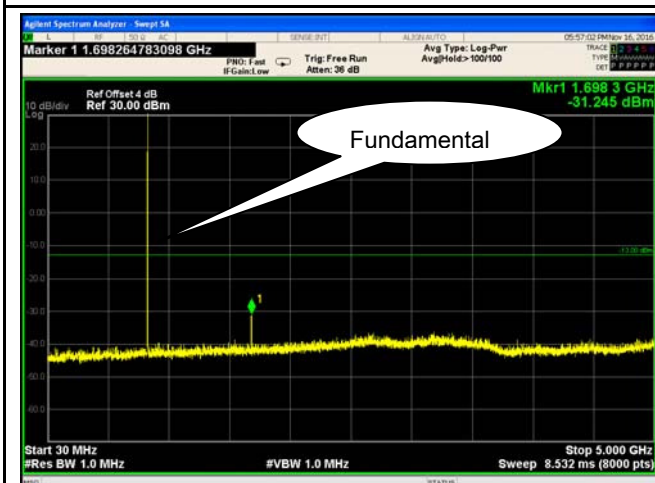

GSM 850 - High Channel-1

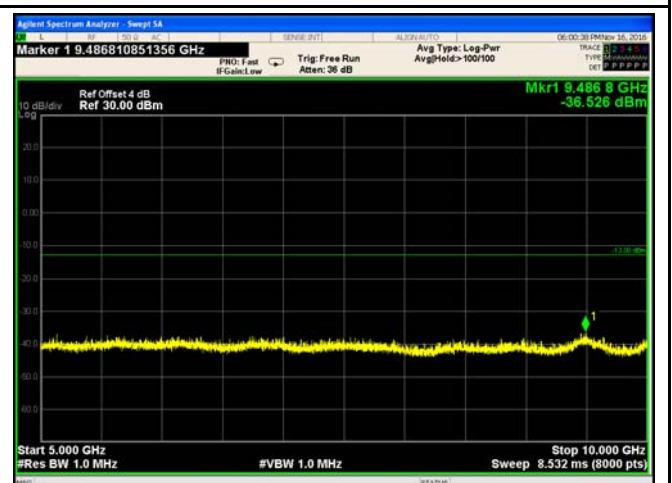

GSM 850 - High Channel-2

**PCS Band (Part24E) result**

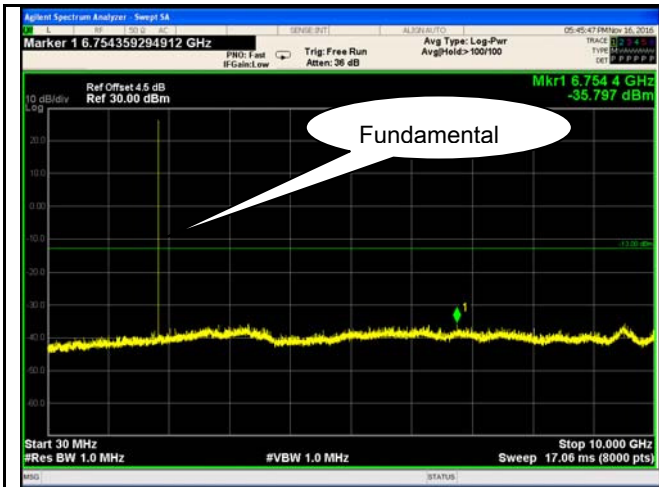

PCS1900 - Low Channel-1

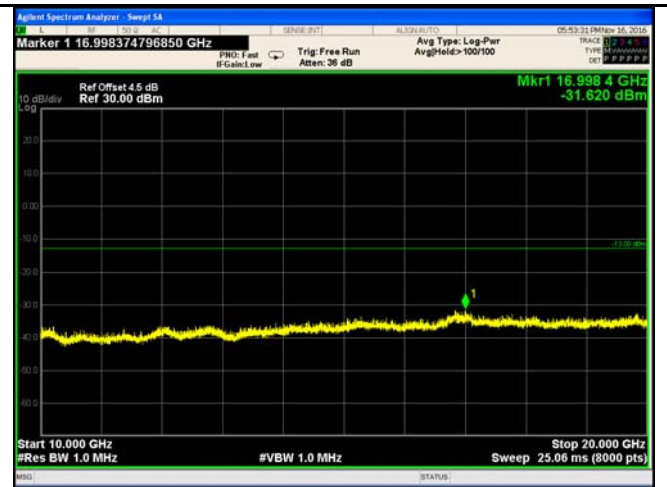

PCS 1900 - Low Channel-2

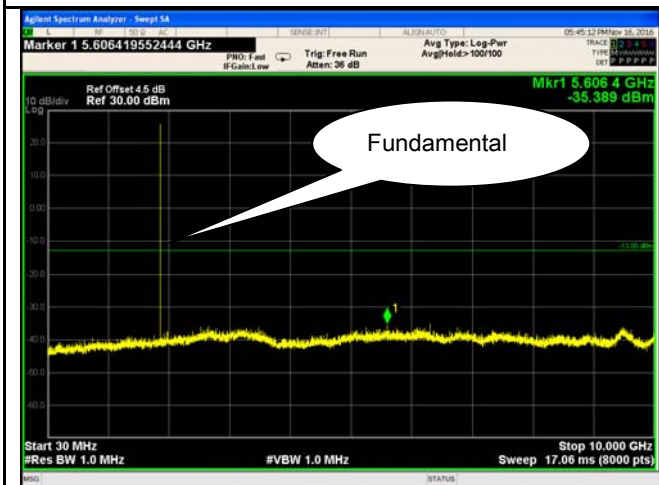

PCS1900 - Middle Channel-1



PCS 1900 - Middle Channel-2

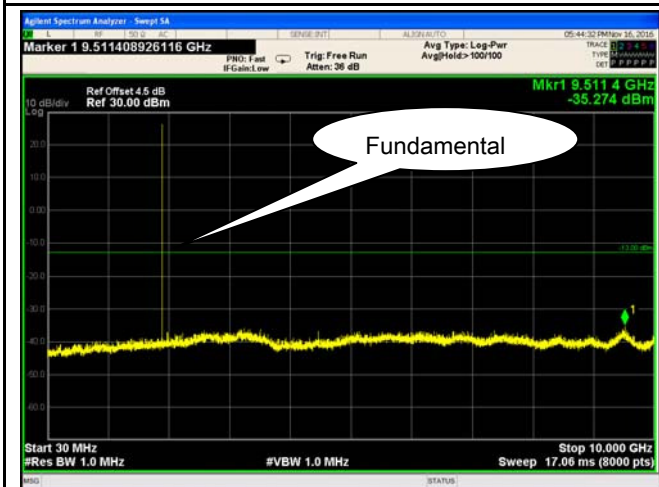

PCS1900 - High Channel-1

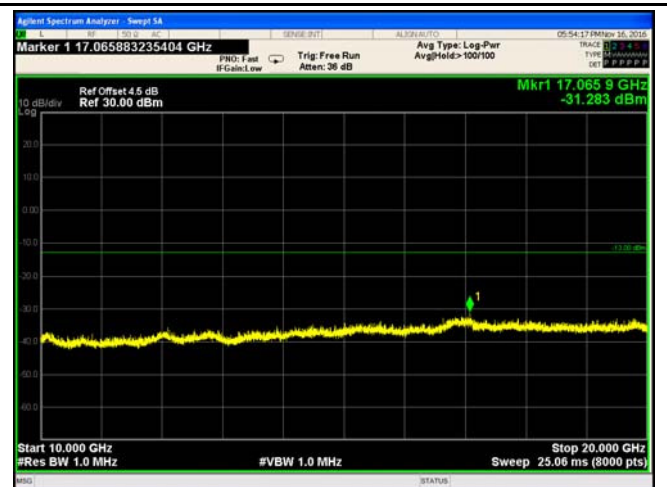

PCS 1900 - High Channel-2

**GPRS:**

**Cellular Band (Part 22H) result**

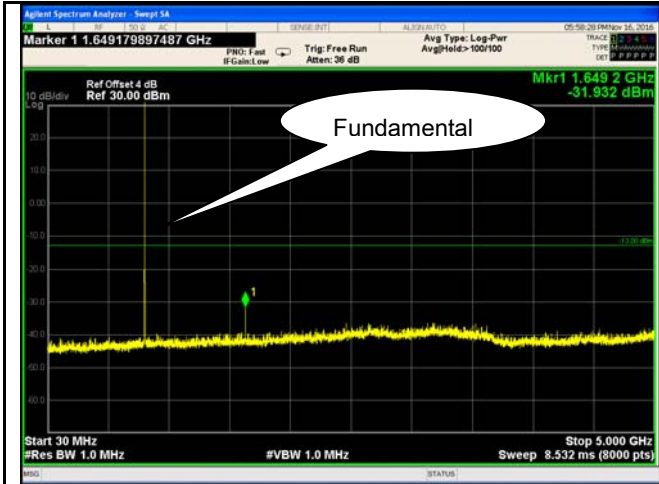

GSM 850 - Low Channel-1

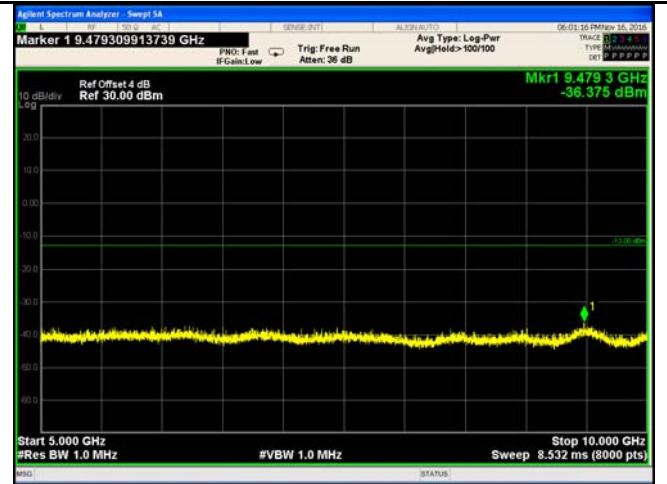

GSM 850 - Low Channel-2

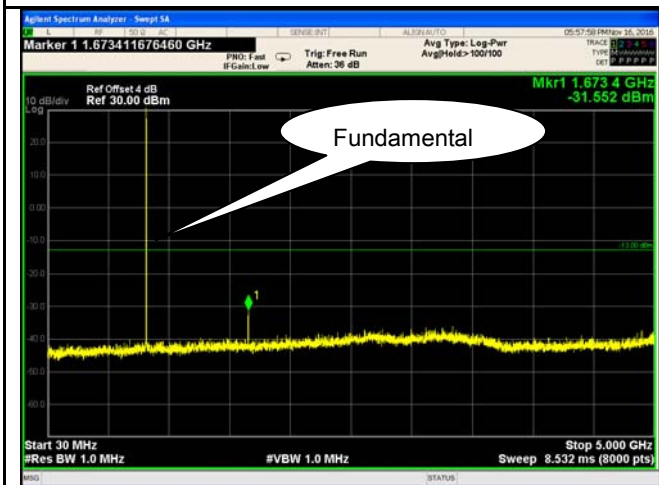

GSM 850 Middle Channel-1

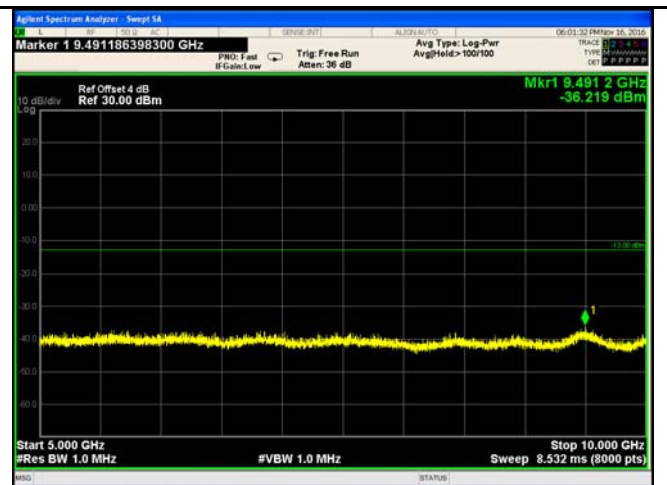

GSM 850 Middle Channel-2

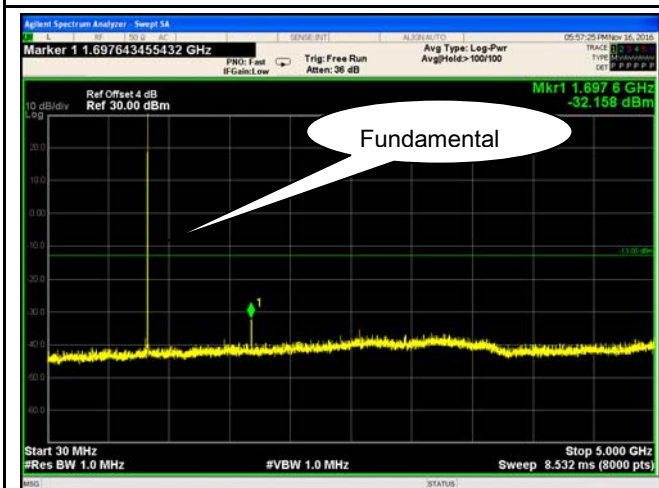

GSM 850 - High Channel-1

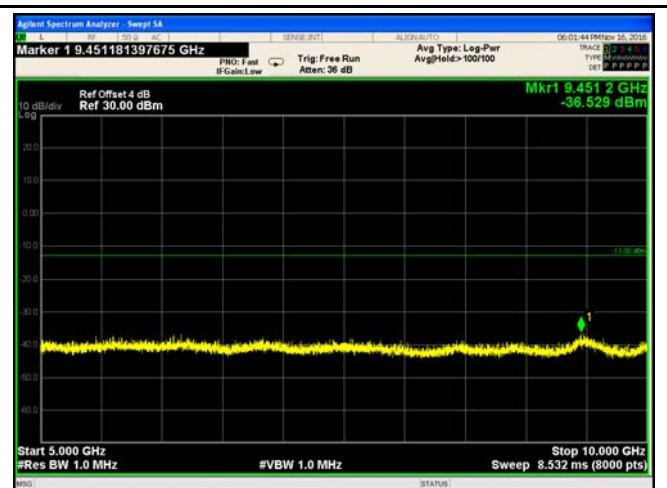

GSM 850 - High Channel-2



PCS Band (Part24E) result

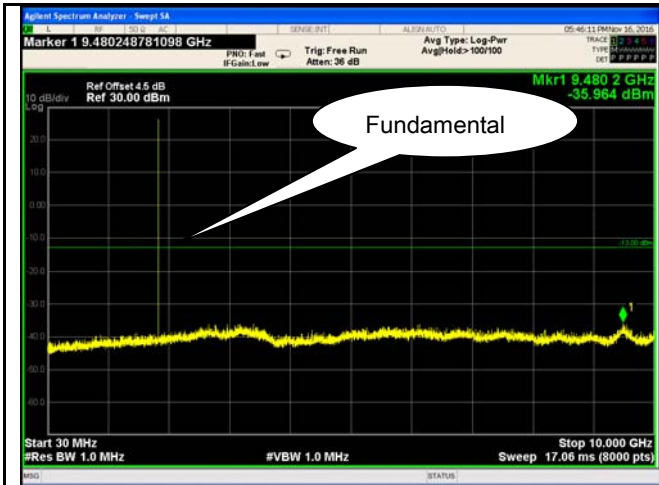

PCS1900 - Low Channel-1

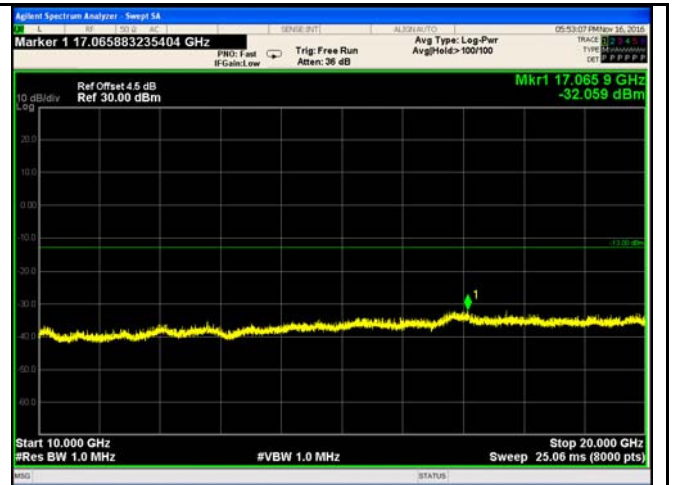

PCS 1900 - Low Channel-2

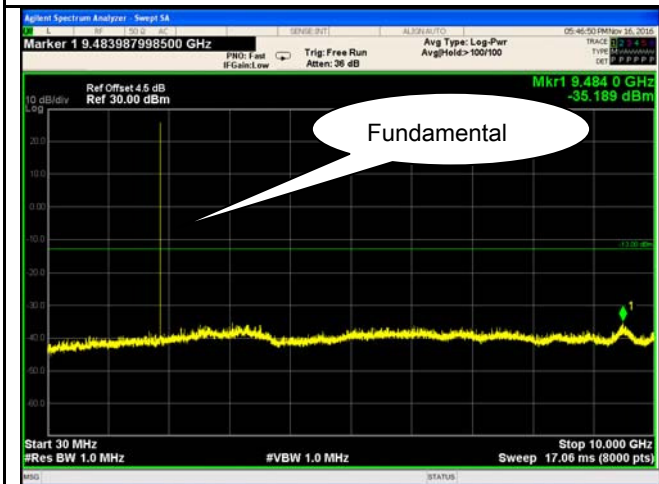

PCS1900 - Middle Channel-1



PCS 1900 - Middle Channel-2

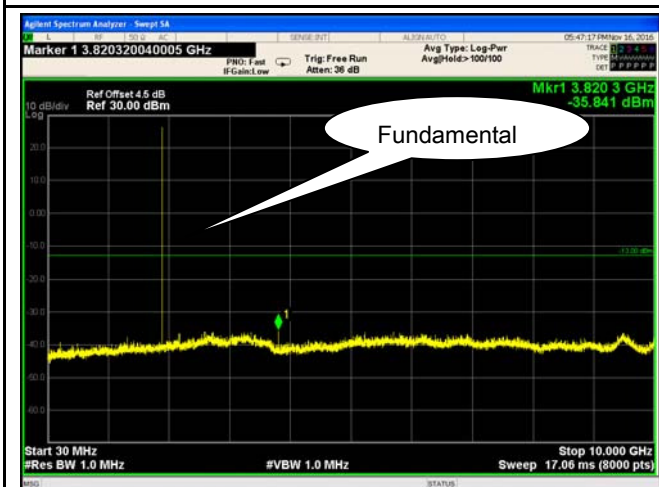

PCS1900 - High Channel-1



PCS 1900 - High Channel-2

**EGPRS (MCS 5):  
 Cellular Band (Part 22H) result**

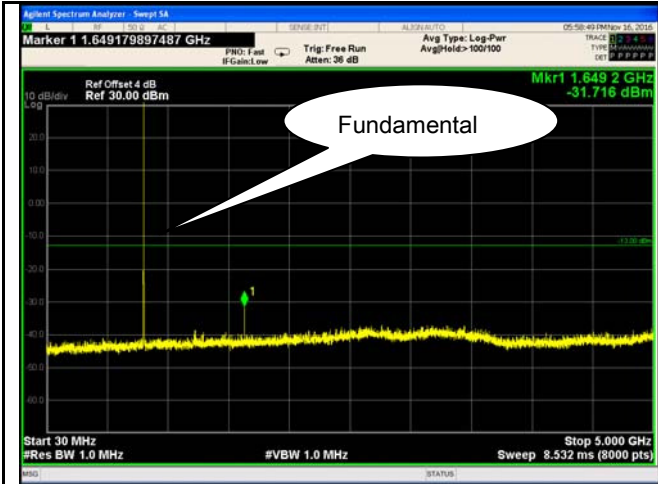

GSM 850 - Low Channel-1

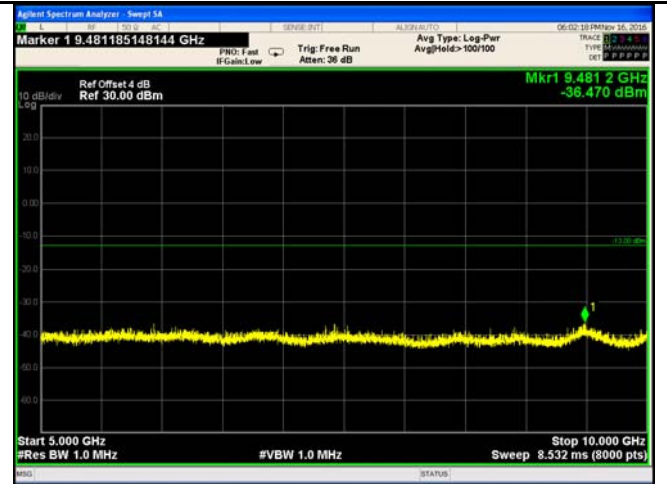

GSM 850 - Low Channel-2

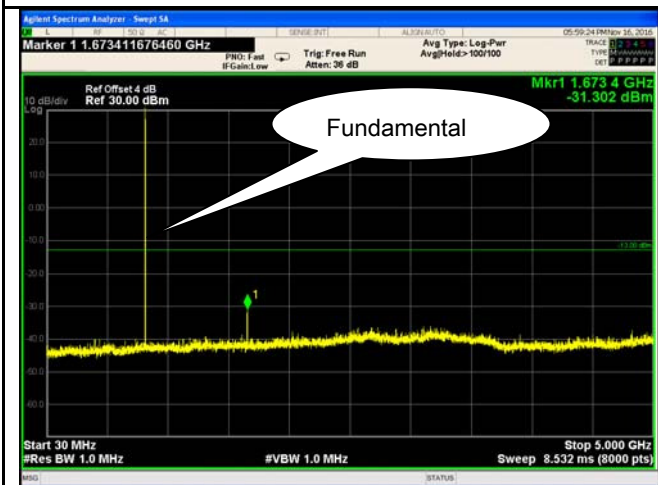

GSM 850 Middle Channel-1

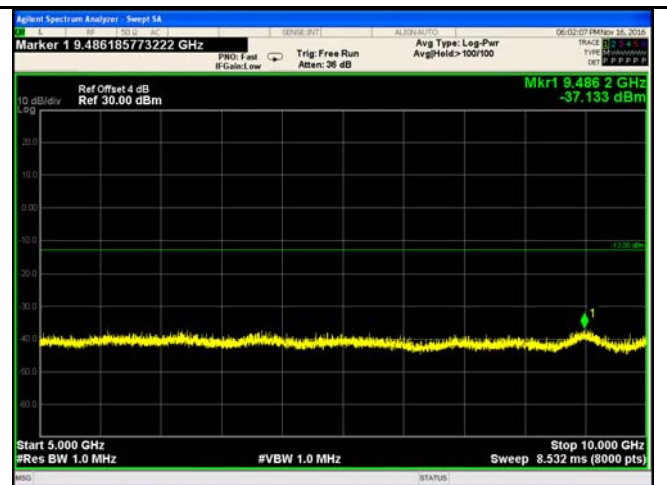

GSM 850 Middle Channel-2

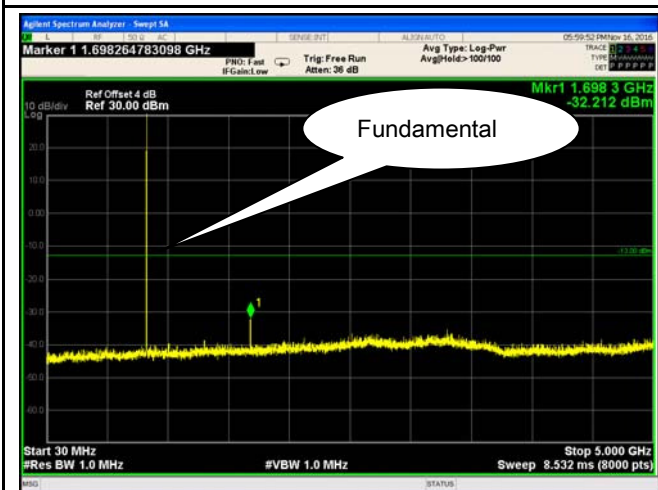

GSM 850 - High Channel-1

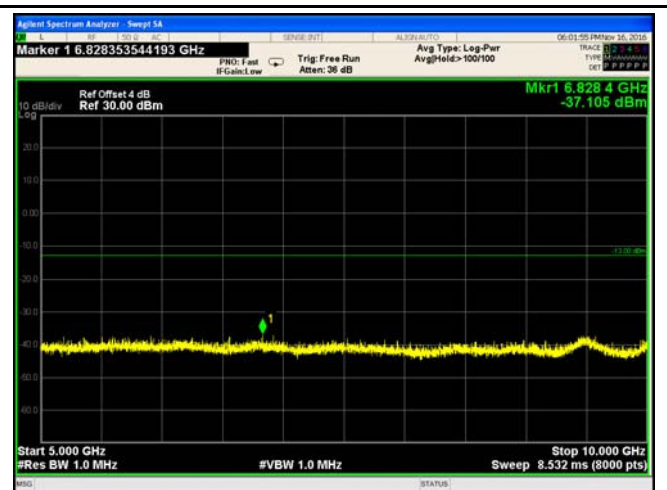

GSM 850 - High Channel-2

**PCS Band (Part24E) result**

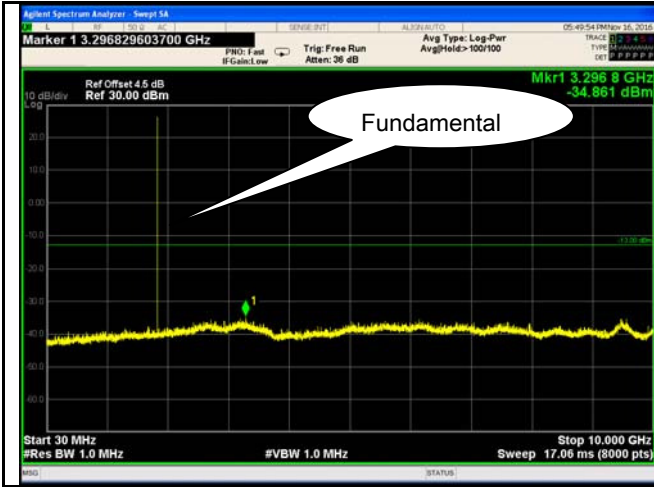

PCS1900 - Low Channel-1

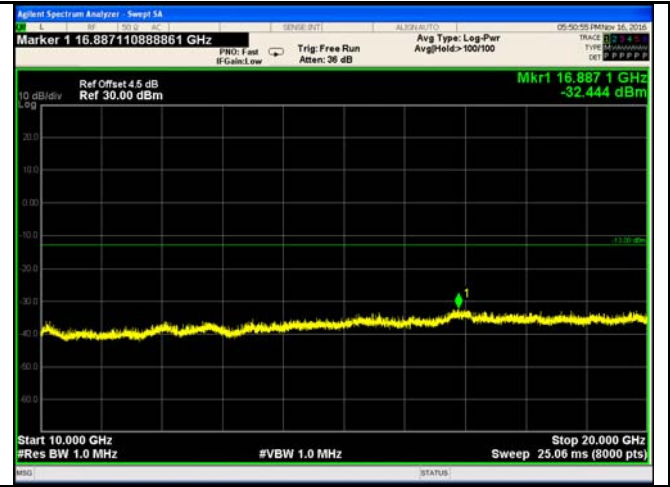

PCS 1900 - Low Channel-2

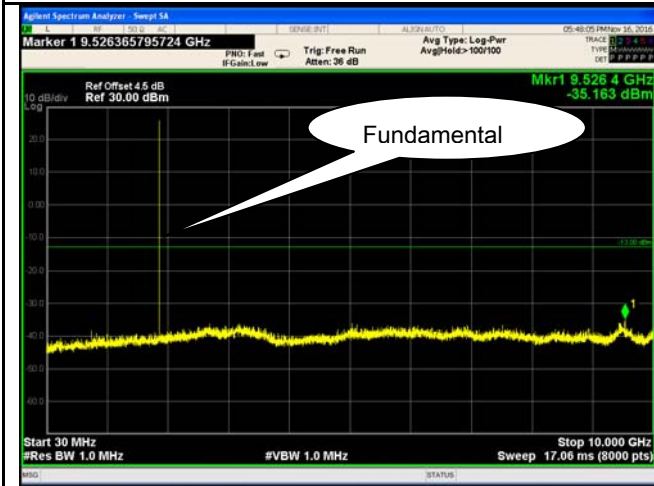

PCS1900 - Middle Channel-1



PCS 1900 - Middle Channel-2

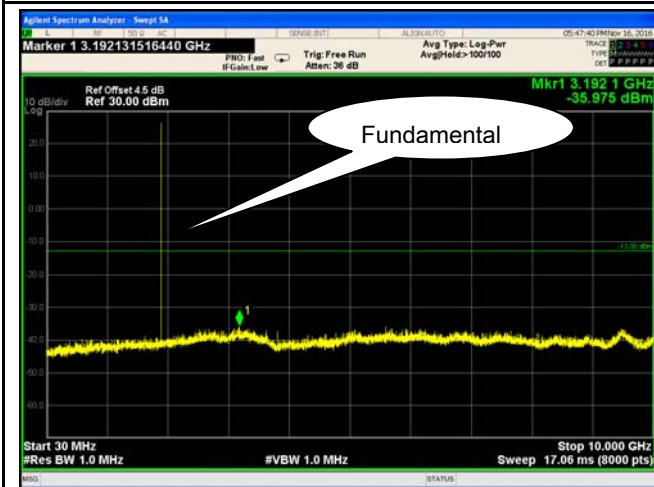

PCS1900 - High Channel-1

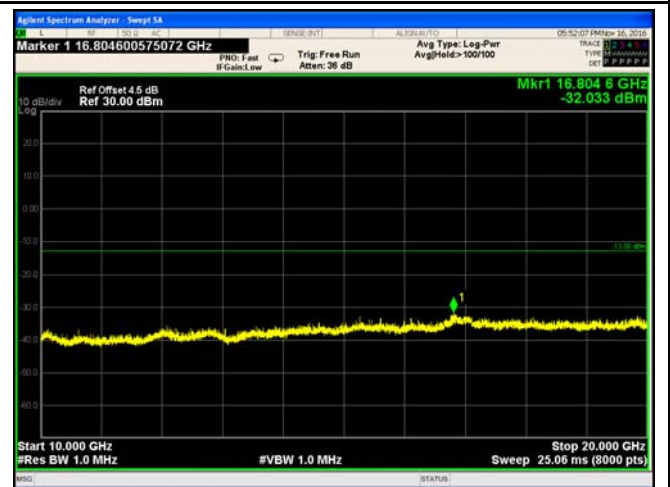

PCS 1900 - High Channel-2

RMC

UMTS-FDD Band V (Part 22H)

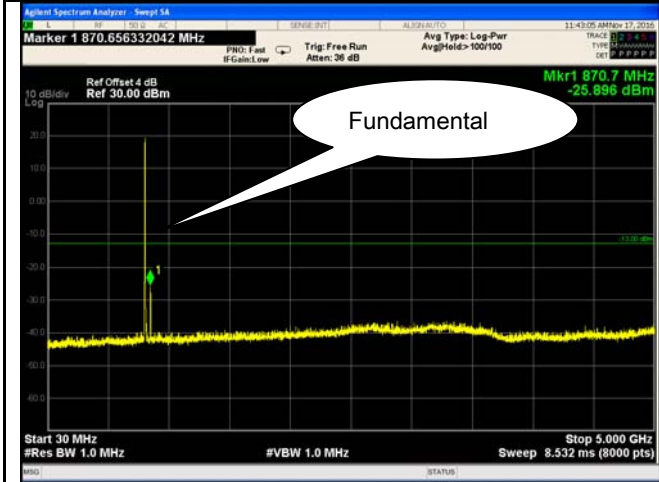

Band V - Low Channel-1

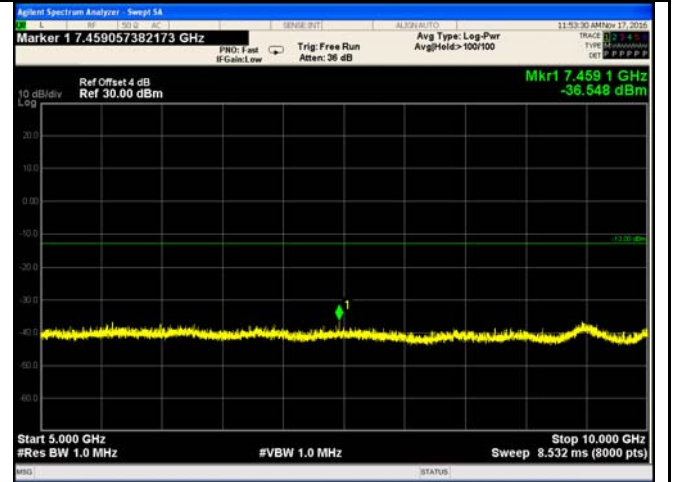

Band V - Low Channel-2

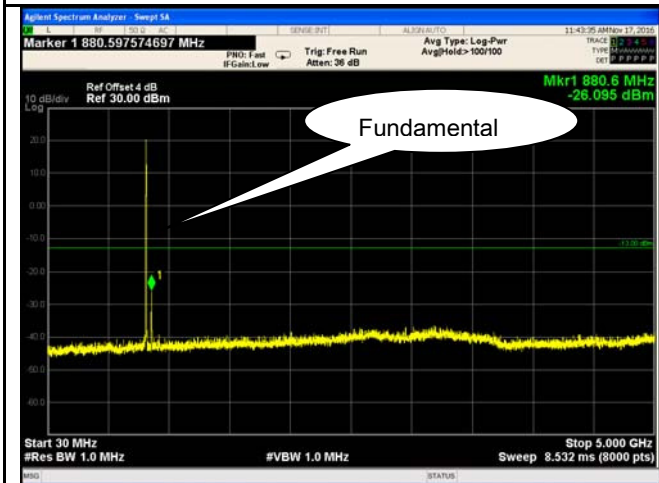

Band V - Middle Channel-1

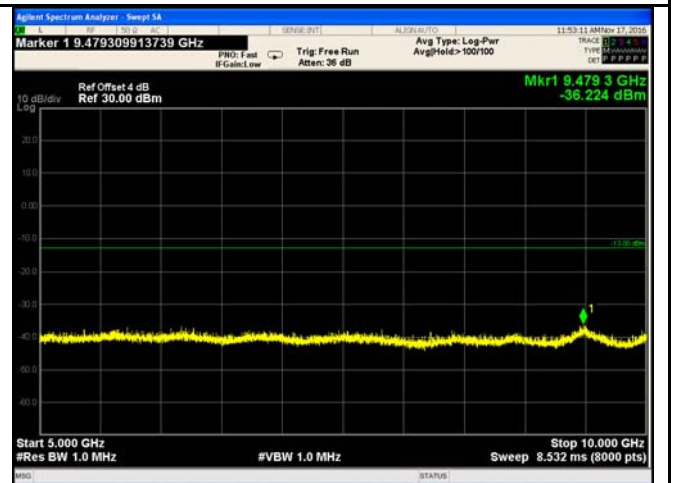

Band V - Middle Channel-2

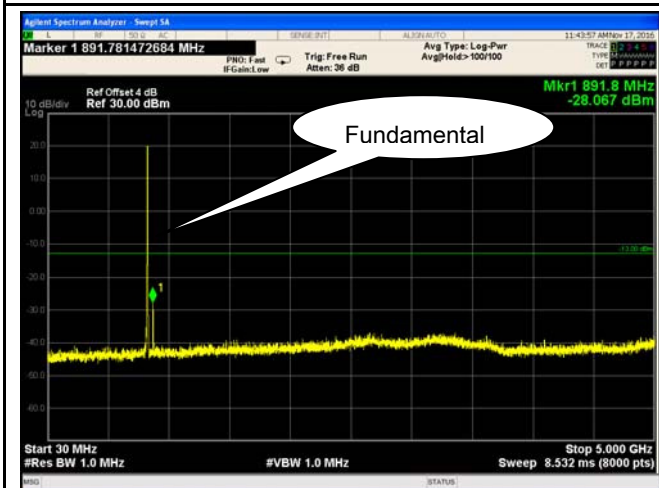

Band V - High Channel-1

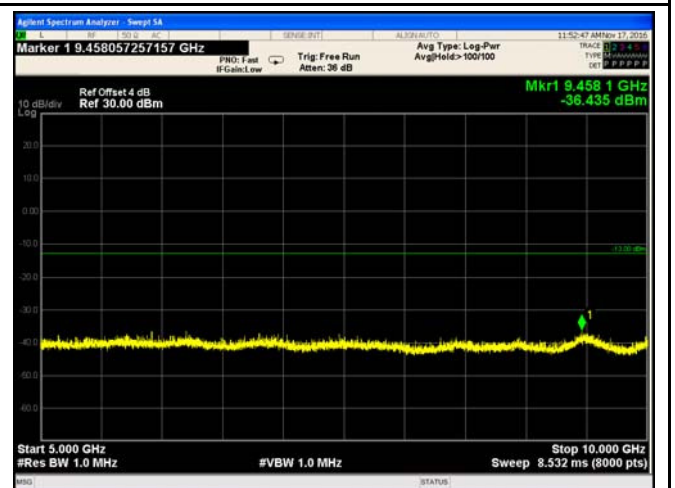

Band V - High Channel-2

**UMTS-FDD Band II (Part 24E)**

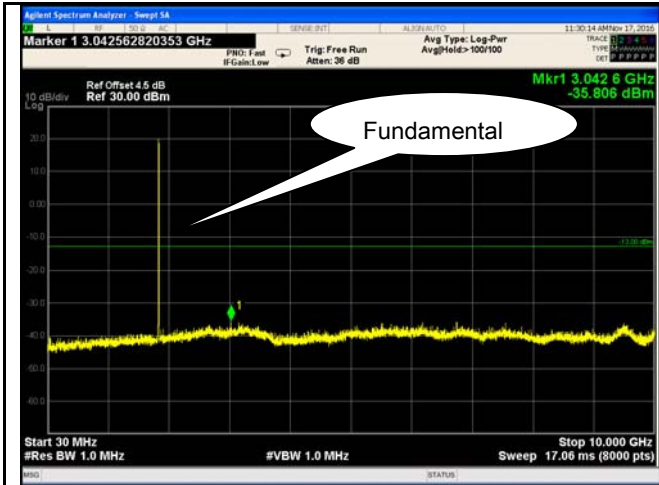

Band II - Low Channel-1

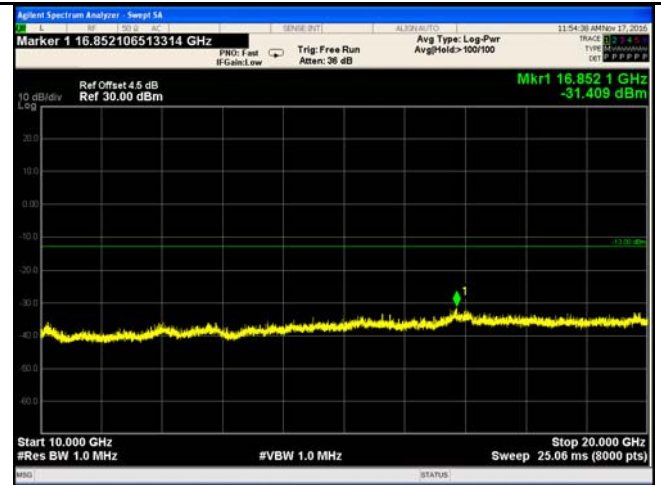

Band II - Low Channel-2

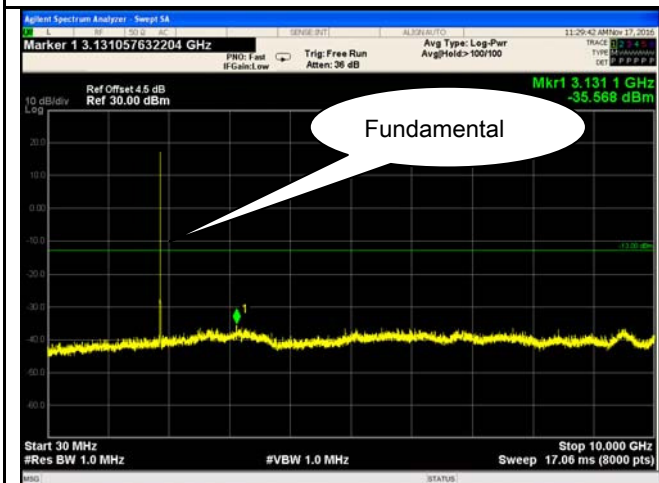

Band II - Middle Channel-1



Band II - Middle Channel-2

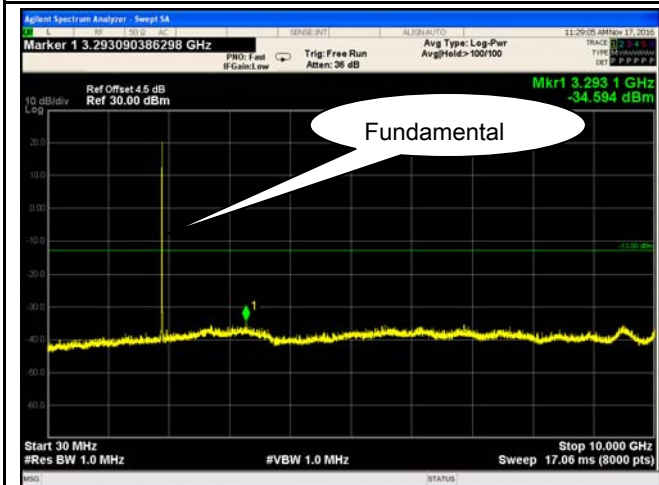

Band II - High Channel-1

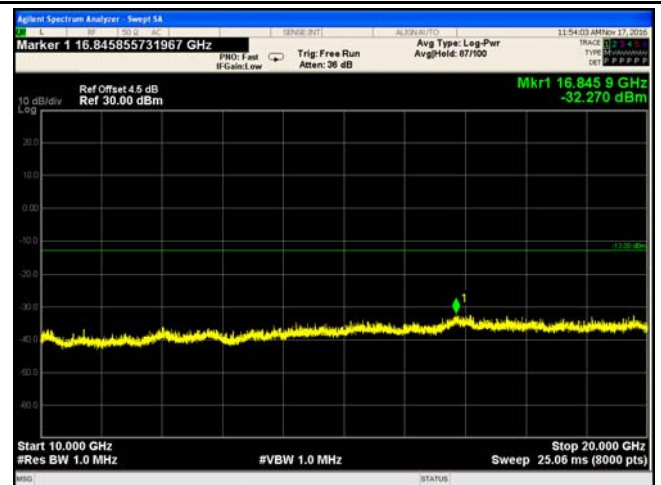

Band II - High Channel-2

**UMTS-FDD Band IV (Part 27)**

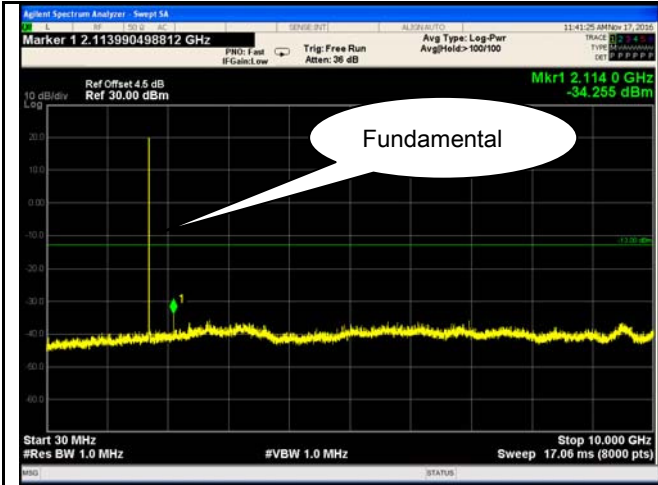

Band IV - Low Channel-1



Band IV - Low Channel-2

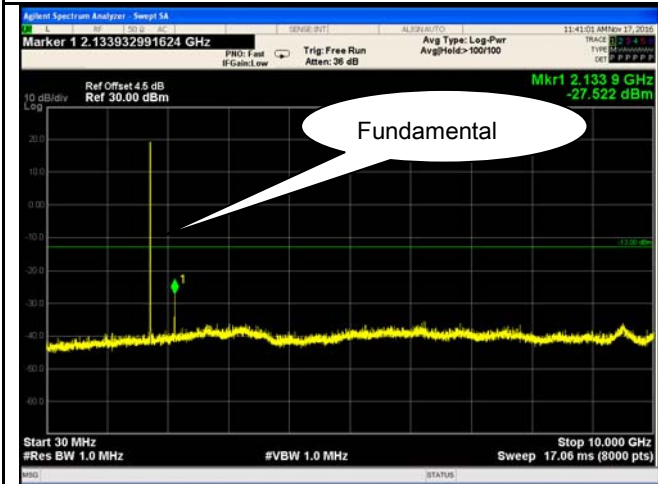

Band IV - Middle Channel-1

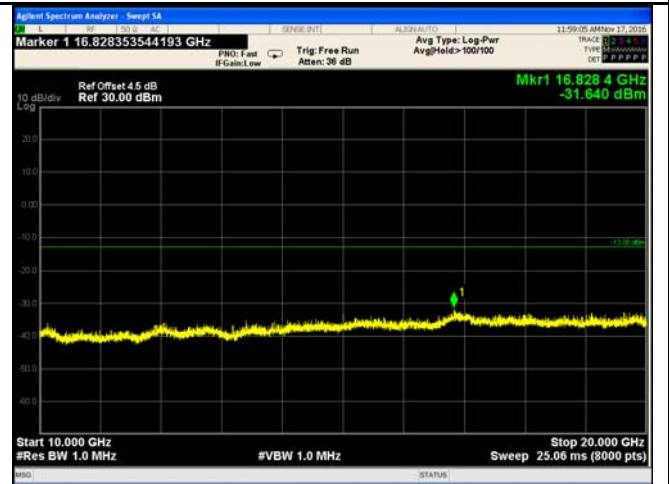

Band IV - Middle Channel-2

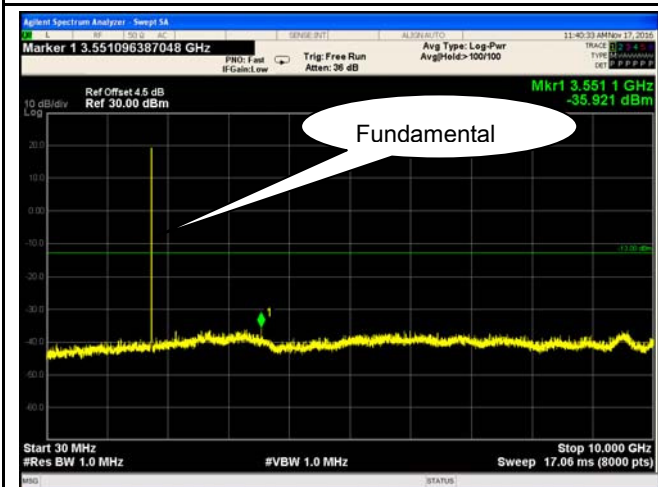

Band IV - High Channel-1

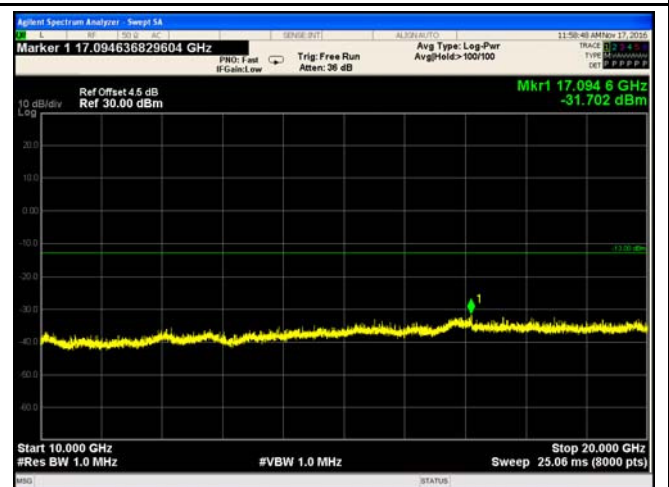

Band IV - High Channel-2

**HSUPA:**

**UMTS-FDD Band V (Part 22H)**

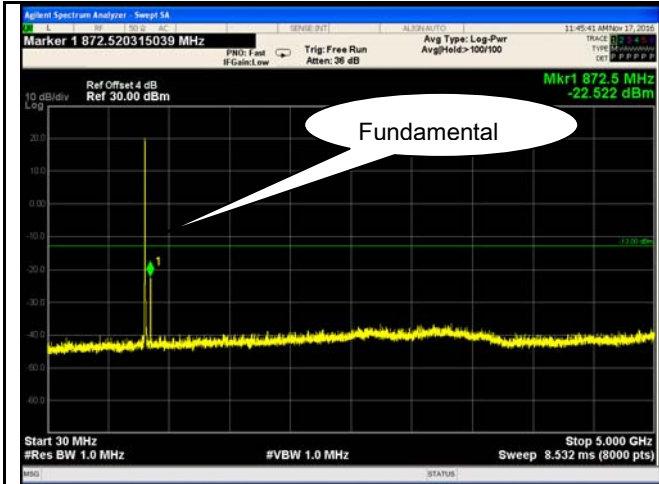

Band V - Low Channel-1

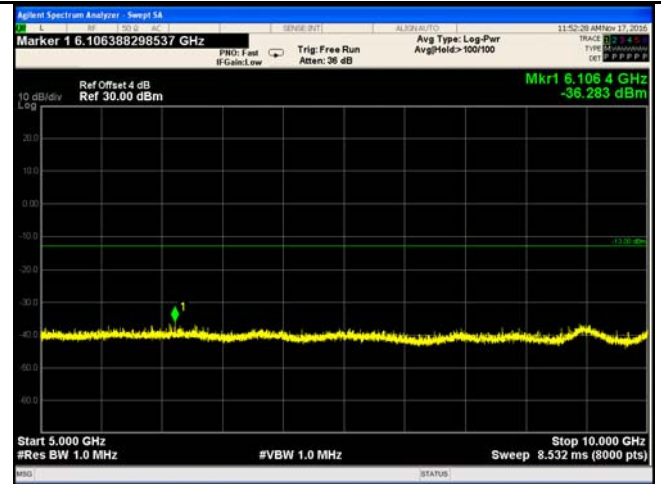

Band V - Low Channel-2

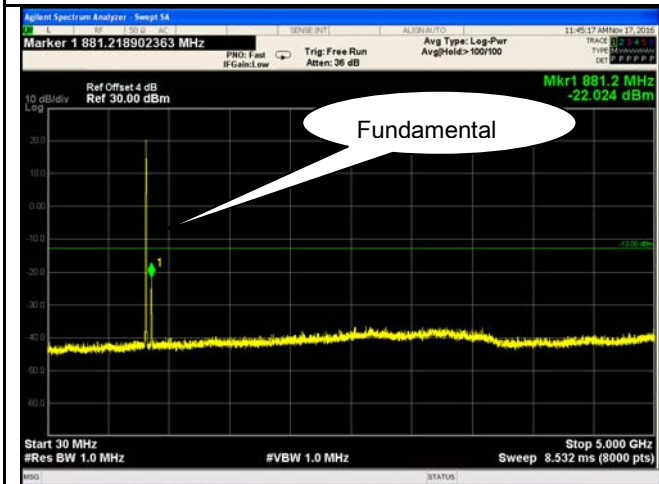

Band V - Middle Channel-1

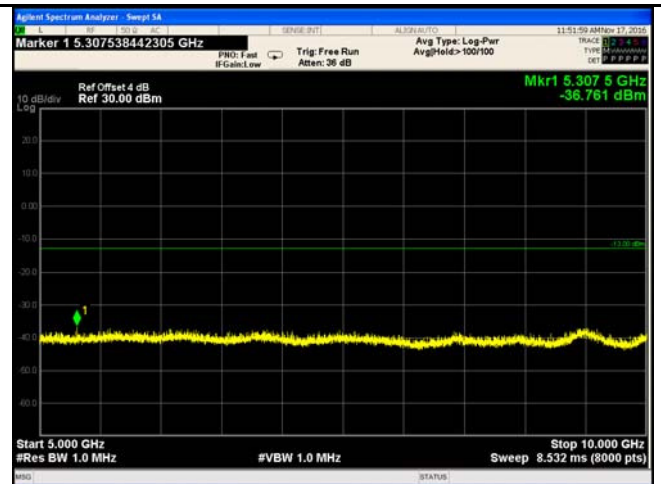

Band V - Middle Channel-2

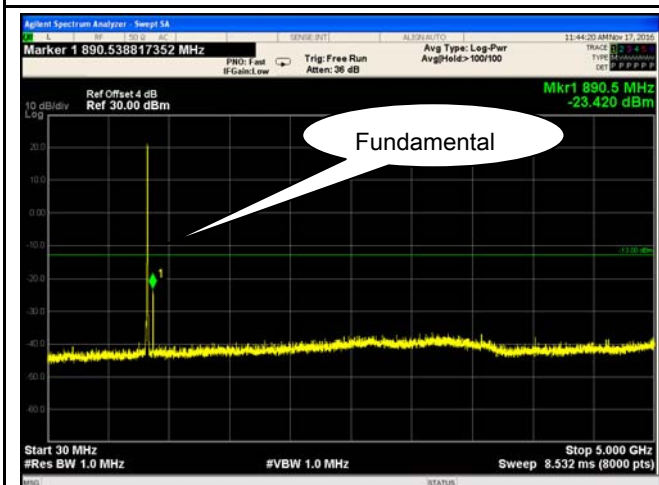

Band V - High Channel-1

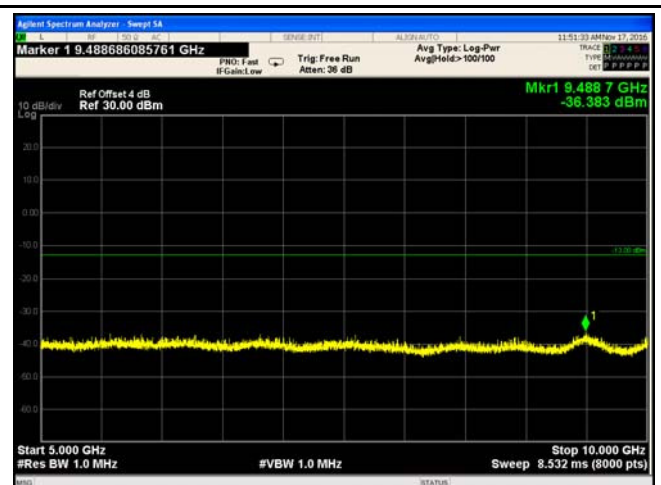

Band V - High Channel-2

**UMTS-FDD Band II (Part 24E)**

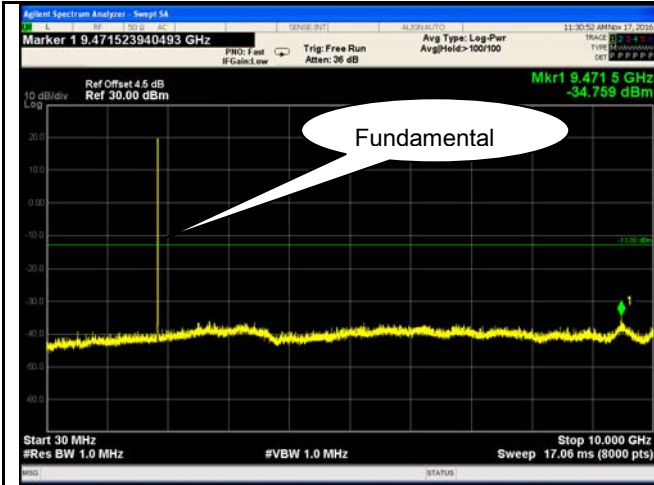

Band II - Low Channel-1



Band II - Low Channel-2

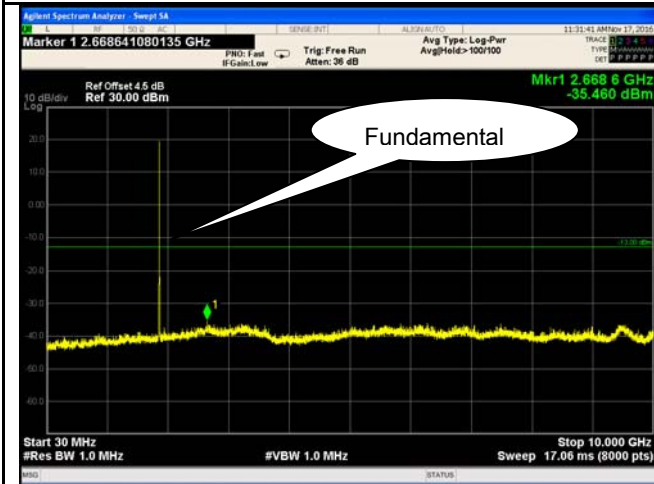

Band II - Middle Channel-1

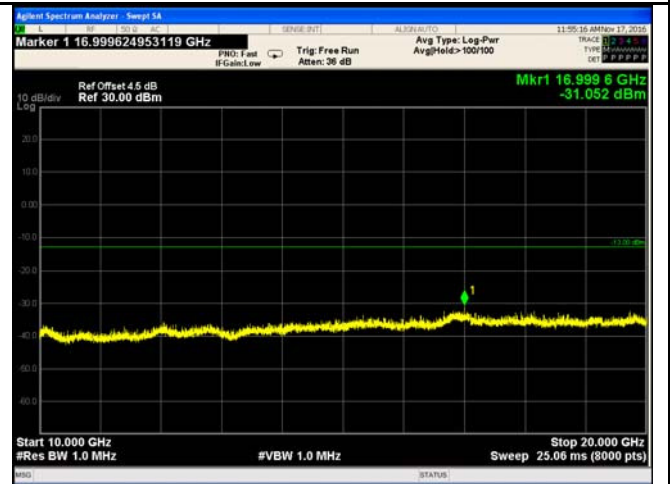

Band II - Middle Channel-2

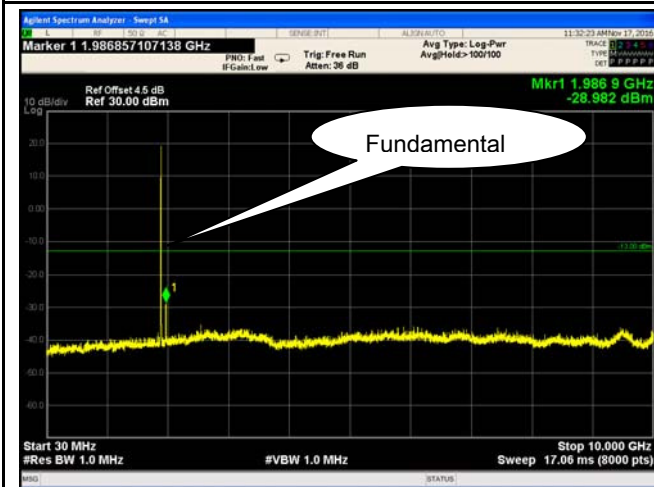

Band II - High Channel-1

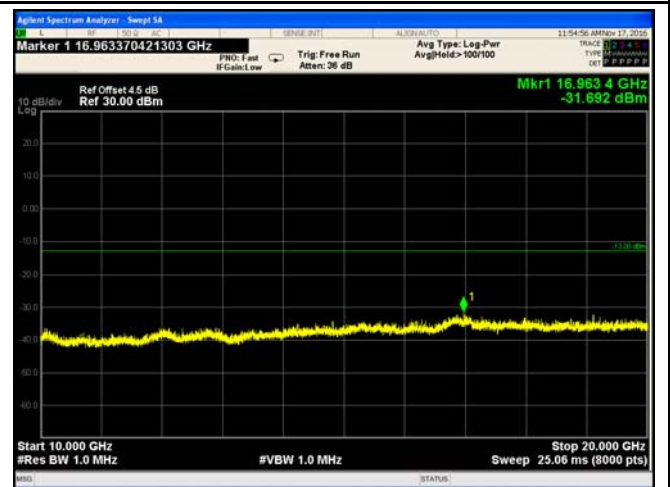

Band II - High Channel-2



**UMTS-FDD Band IV (Part 27)**

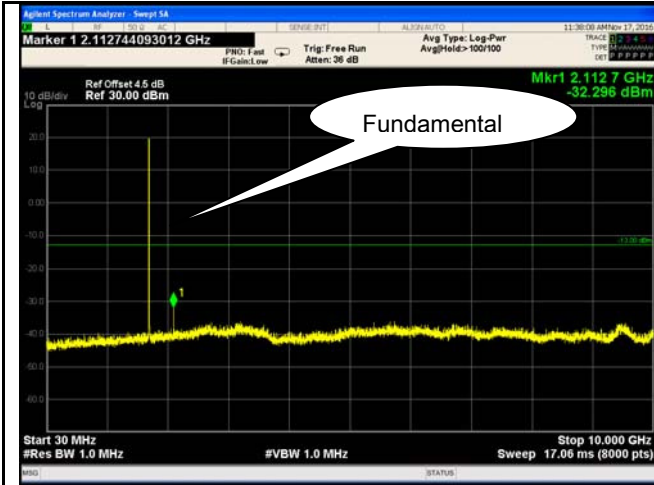

Band IV - Low Channel-1

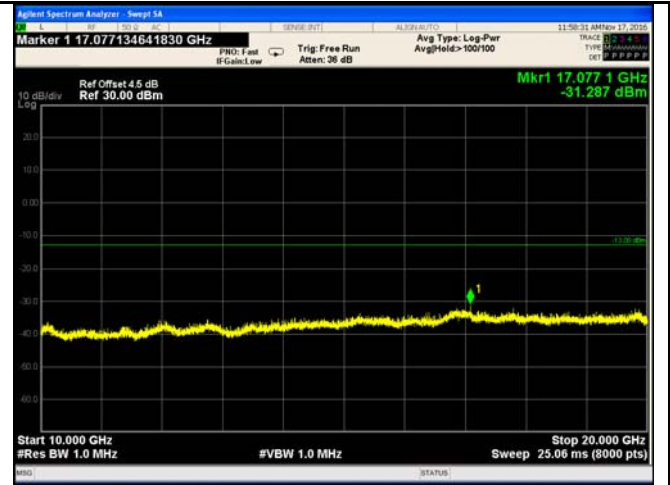

Band IV - Low Channel-2

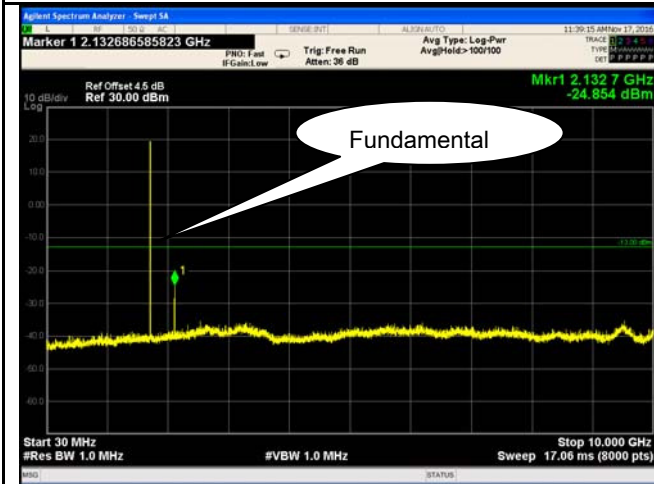

Band IV - Middle Channel-1

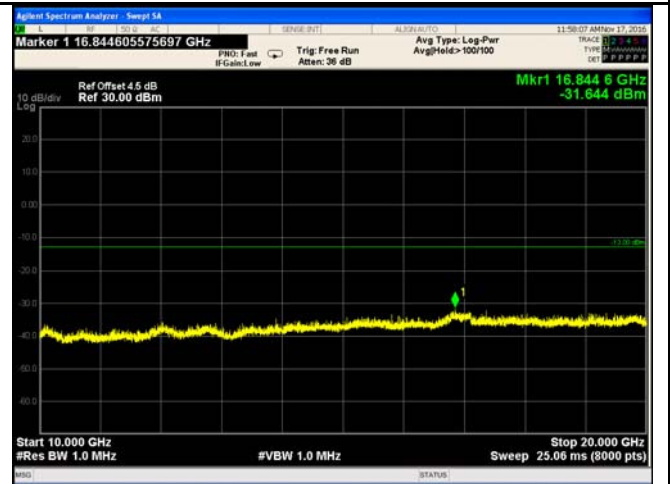

Band IV - Middle Channel-2

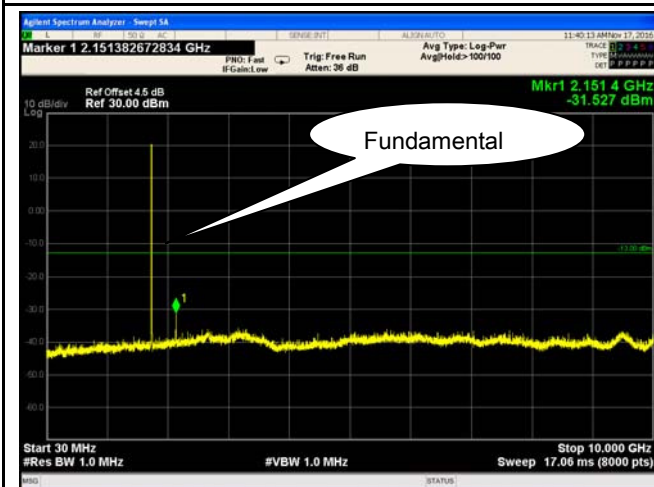

Band IV - High Channel-1

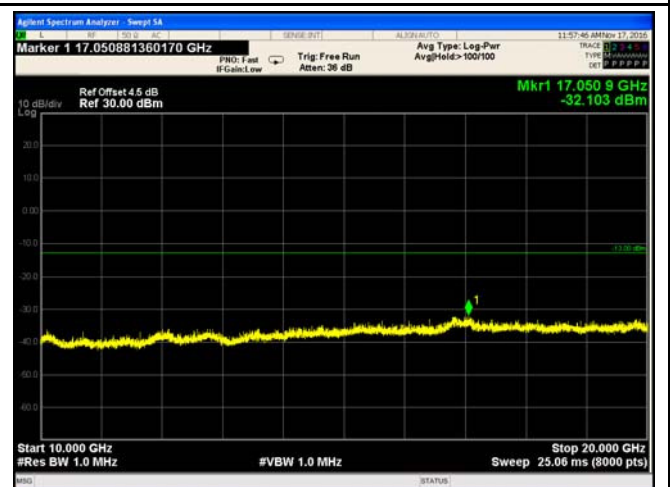

Band IV - High Channel-2

**HSDPA:**

**UMTS-FDD Band V (Part 22H)**

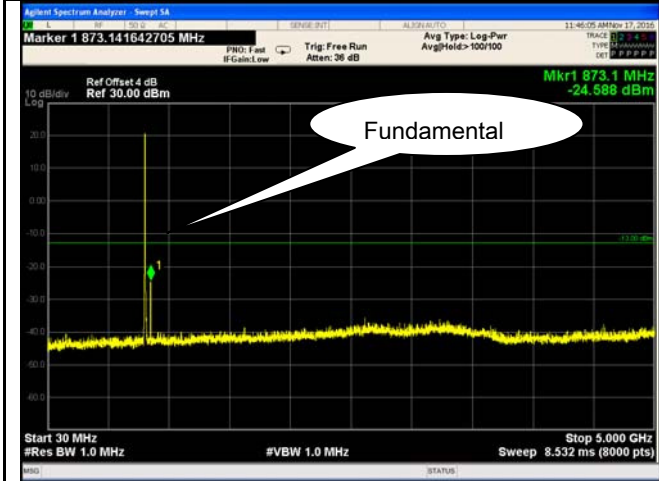

Band V - Low Channel-1

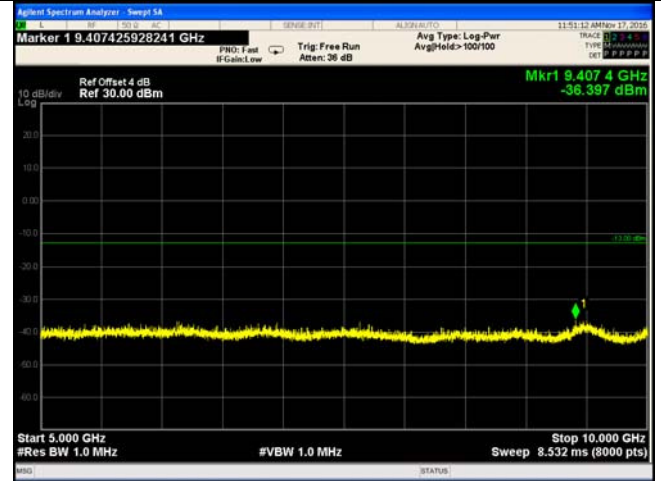

Band V - Low Channel-2

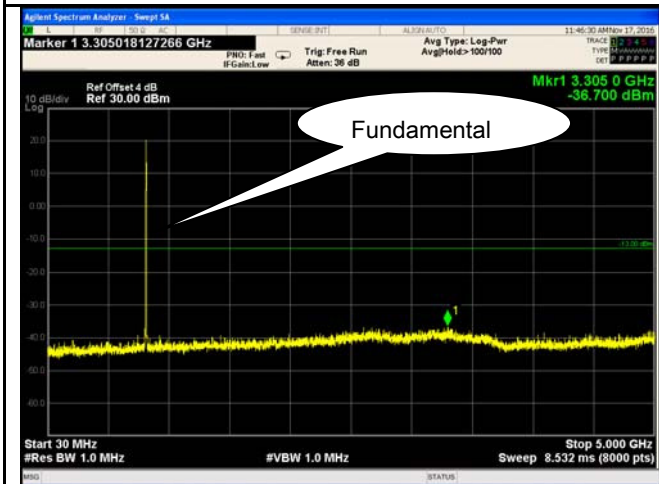

Band V - Middle Channel-1

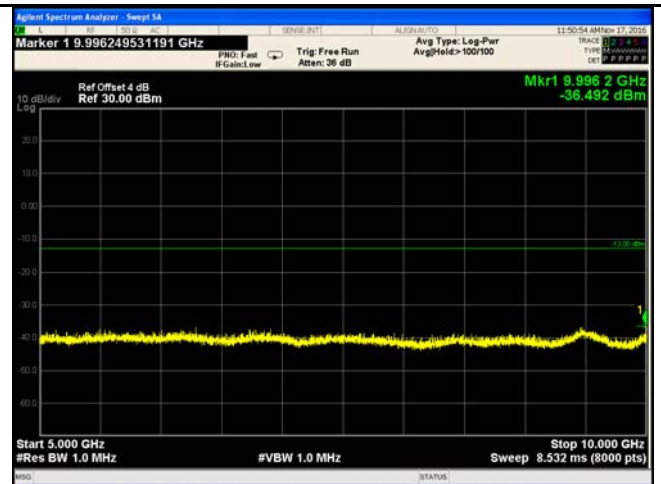

Band V - Middle Channel-2

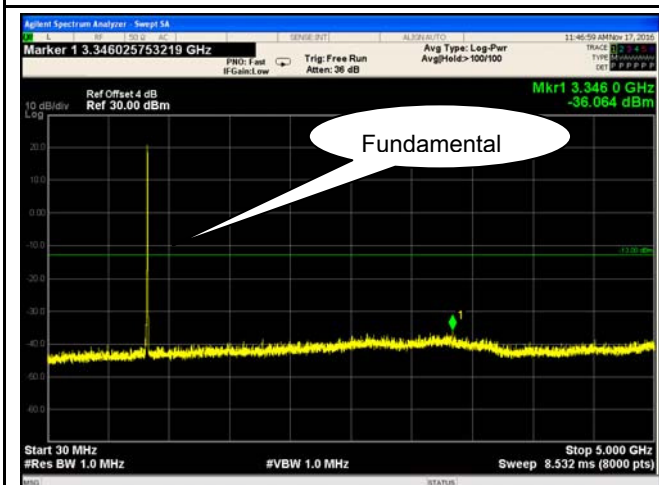

Band V - High Channel-1

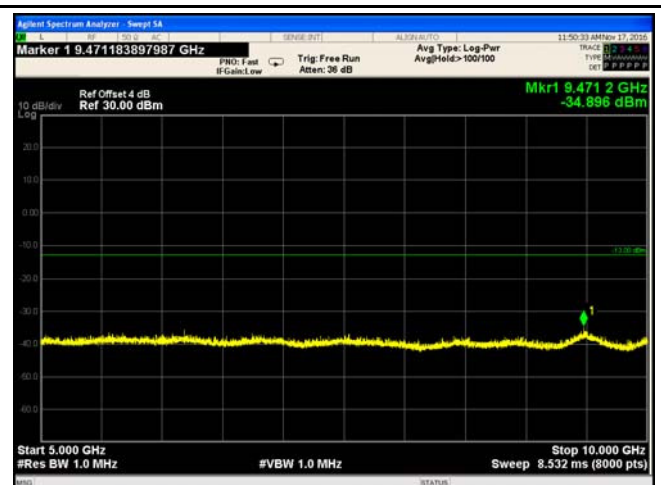

Band V - High Channel-2

**UMTS-FDD Band II (Part 24E)**

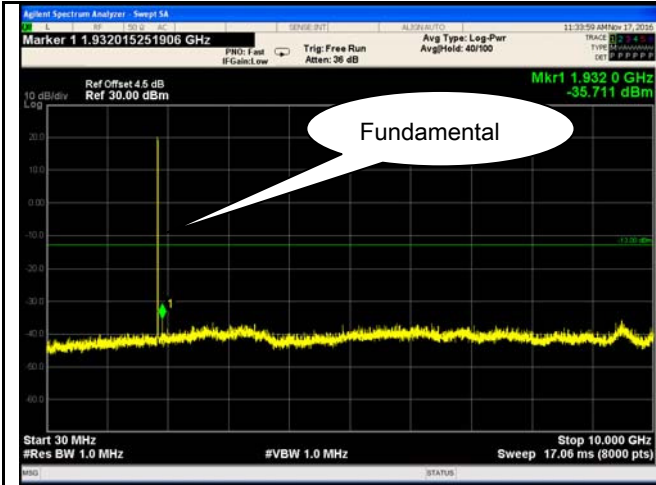

Band II - Low Channel-1

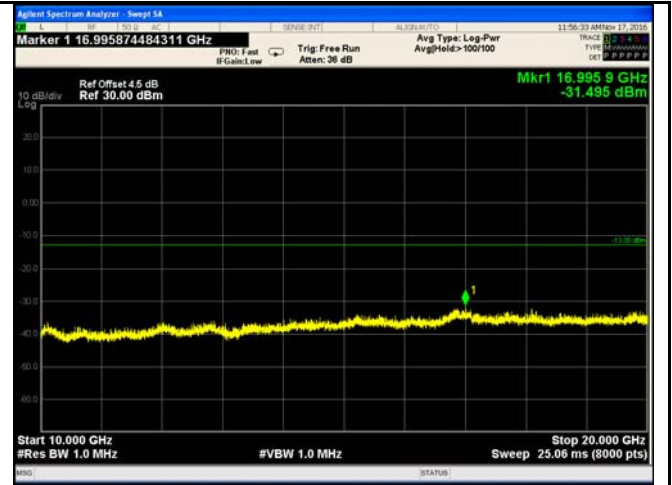

Band II - Low Channel-2

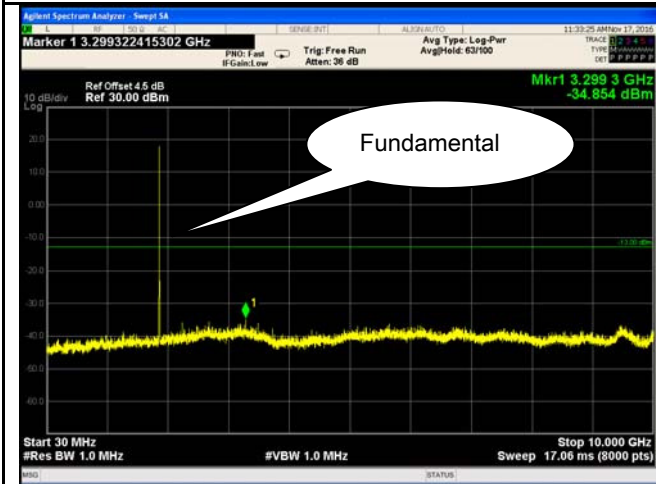

Band II - Middle Channel-1

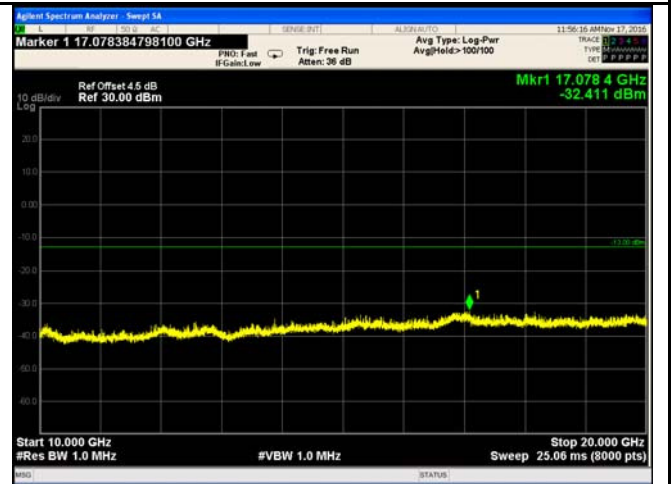

Band II - Middle Channel-2

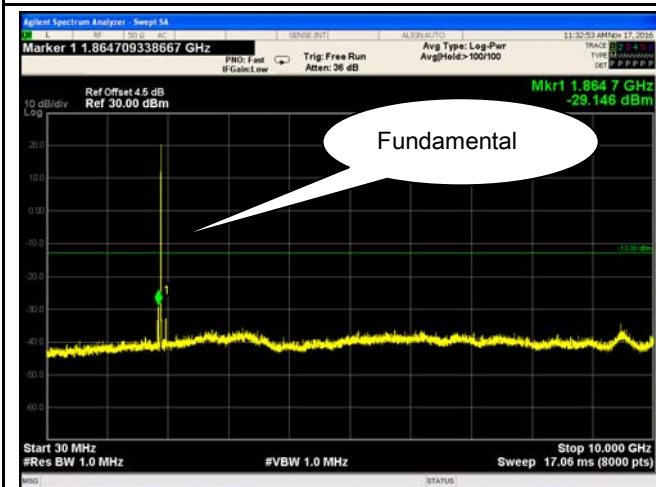

Band II - High Channel-1

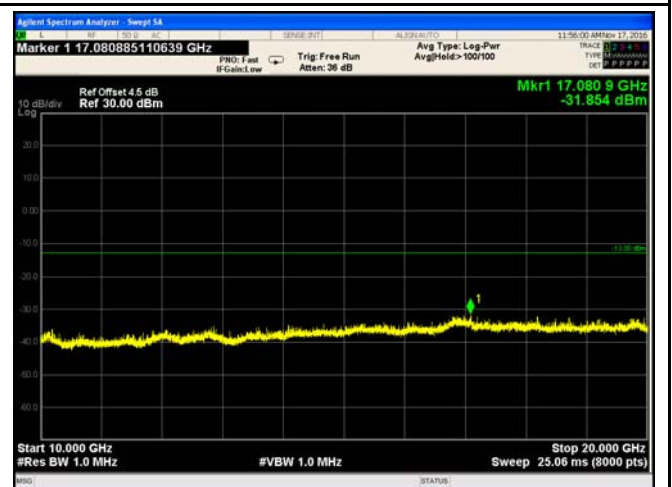

Band II - High Channel-2

**UMTS-FDD Band IV (Part 27)**

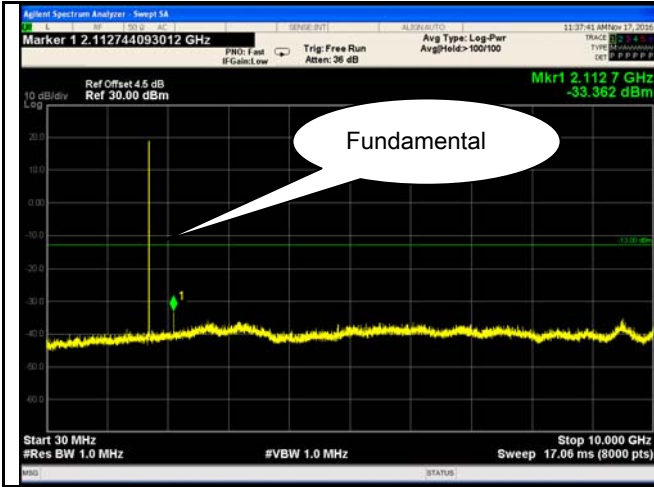

Band IV - Low Channel-1

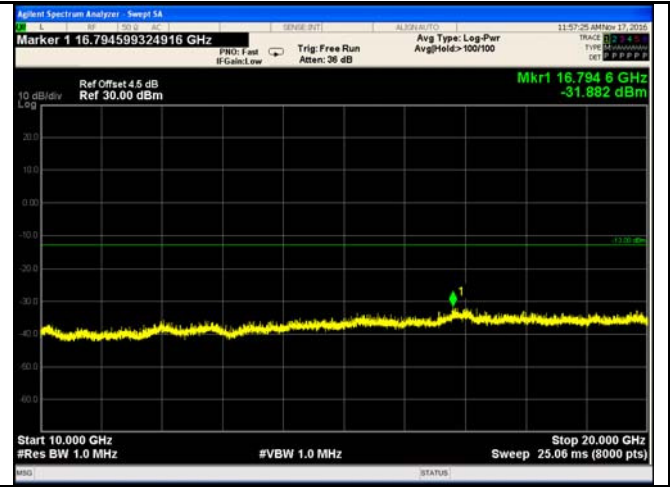

Band IV - Low Channel-2

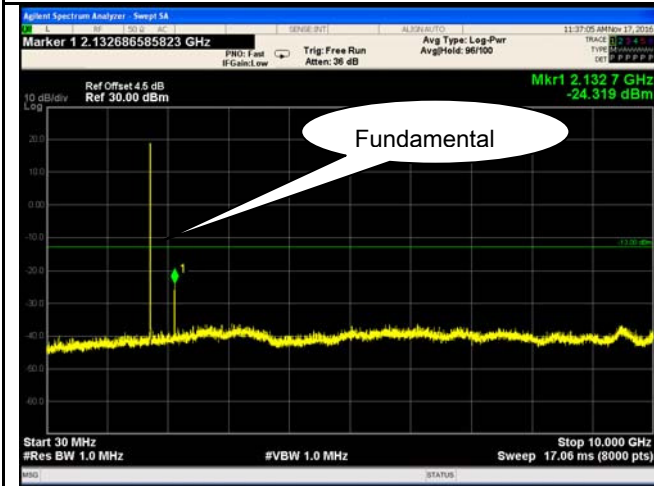

Band IV - Middle Channel-1

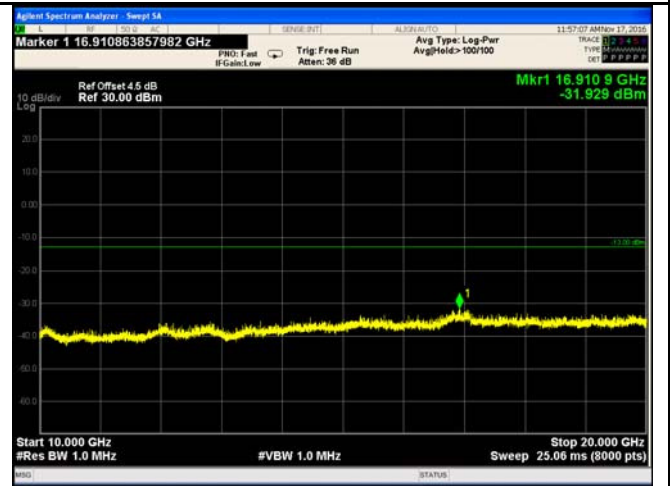

Band IV - Middle Channel-2

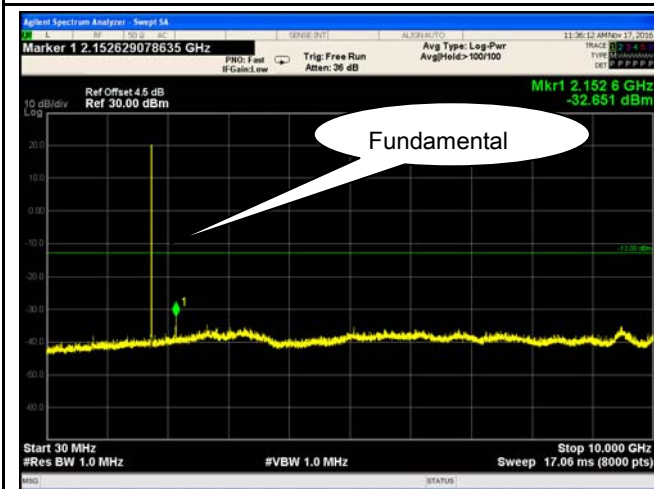

Band IV - High Channel-1

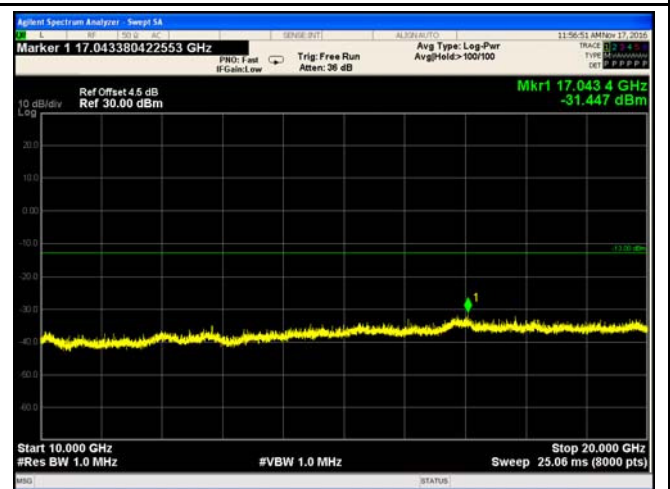

Band IV - High Channel-2

## 6.6 Spurious Radiated Emissions

Temperature	22°C
Relative Humidity	59%
Atmospheric Pressure	1017mbar
Test date :	November 17, 2016
Tested By :	Loren Luo

### Requirement(s):

Spec	Item	Requirement	Applicable
§2.1053, §22.917 & §24.238 § 27.53(h)	a)	The power of any emission outside of the authorized operating frequency ranges must be attenuated below the transmitter power (P) by a factor of at least $43 + 10 \log (P)$ dB. The spectrum is scanned from 30 MHz up to a frequency including its 10th harmonic.	<input checked="" type="checkbox"/>

Test setup	
------------	--

Test Procedure	<ol style="list-style-type: none"> <li>The transmitter was placed on a wooden turntable, and it was transmitting into a non-radiating load which was also placed on the turntable.</li> <li>The measurement antenna was placed at a distance of 3 meters from the EUT. During the tests, the antenna height and polarization as well as EUT azimuth were varied in order to identify the maximum level of emissions from the EUT. The test was performed by placing the EUT on 3-orthogonal axis.</li> <li>Remove the EUT and replace it with substitution antenna. A signal generator was connected to the substitution antenna by a non-radiating cable. The absolute levels of the spurious emissions were measured by the substitution. Sample Calculation: EUT Field Strength = Raw Amplitude (dBµV/m) – Amplifier Gain (dB) + Antenna Factor (dB) + Cable Loss (dB) + Filter Attenuation (dB, if used)</li> </ol>
----------------	---

Test Report	16071314-FCC-R1-V1
Page	62 of 99

Remark	
Result	<input checked="" type="checkbox"/> Pass <input type="checkbox"/> Fail

**Test Data**  Yes  N/A  
**Test Plot**  Yes (See below)  N/A

## Cellular Band (Part 22H) result

### Low channel

Frequency (MHz)	Substituted level (dBm)	Polarity (H/V)	Antenna Gain Correction (dB)	Cable Loss (dB)	Corrected Reading (dBm)	Limit (dBm)	Margin (dB)
1648.4	-43.62	V	7.95	0.78	-36.45	-13	-23.45
1648.4	-44.86	H	7.95	0.78	-37.69	-13	-24.69
326.4	-52.73	V	6.4	0.26	-46.59	-13	-33.59
602.3	-52.94	H	6.8	0.37	-46.51	-13	-33.51

### Middle channel

Frequency (MHz)	Substituted level (dBm)	Polarity (H/V)	Antenna Gain Correction (dB)	Cable Loss (dB)	Corrected Reading (dBm)	Limit (dBm)	Margin (dB)
1673.2	-43.85	V	7.95	0.78	-36.68	-13	-23.68
1673.2	-43.92	H	7.95	0.78	-36.75	-13	-23.75
327.5	-52.13	V	6.4	0.26	-45.99	-13	-32.99
604.3	-52.48	H	6.8	0.37	-46.05	-13	-33.05

### High channel

Frequency (MHz)	Substituted level (dBm)	Polarity (H/V)	Antenna Gain Correction (dB)	Cable Loss (dB)	Corrected Reading (dBm)	Limit (dBm)	Margin (dB)
1697.6	-43.16	V	7.95	0.78	-35.99	-13	-22.99
1697.6	-43.56	H	7.95	0.78	-36.39	-13	-23.39
328.6	-52.84	V	6.4	0.26	-46.7	-13	-33.70
603.4	-52.73	H	6.8	0.37	-46.3	-13	-33.30

#### Note:

- 1, The testing has been conformed to  $10 \times 848.8 \text{ MHz} = 8,488 \text{ MHz}$
- 2, All other emissions more than 30 dB below the limit
- 3, GSM voice, GPRS and EGPRS mode were investigated. The results above show only the worse cases
- 4, X-Axis, Y-Axis and Z-Axis were investigated. The results above show only the worst case.

## PCS Band (Part24E) result

### Low channel

Frequency (MHz)	Substituted level (dBm)	Polarity (H/V)	Antenna Gain Correction (dB)	Cable Loss (dB)	Corrected Reading (dBm)	Limit (dBm)	Margin (dB)
3700.4	-48.57	V	10.25	2.73	-41.05	-13	-28.05
3700.4	-49.08	H	10.25	2.73	-41.56	-13	-28.56
327.9	-53.64	V	6.4	0.26	-47.5	-13	-34.50
605.3	-53.42	H	6.8	0.37	-46.99	-13	-33.99

### Middle channel

Frequency (MHz)	Substituted level (dBm)	Polarity (H/V)	Antenna Gain Correction (dB)	Cable Loss (dB)	Corrected Reading (dBm)	Limit (dBm)	Margin (dB)
3760	-48.23	V	10.25	2.73	-40.71	-13	-27.71
3760	-48.75	H	10.25	2.73	-41.23	-13	-28.23
326.7	-53.46	V	6.4	0.26	-47.32	-13	-34.32
605.2	-53.72	H	6.8	0.37	-47.29	-13	-34.29

### High channel

Frequency (MHz)	Substituted level (dBm)	Polarity (H/V)	Antenna Gain Correction (dB)	Cable Loss (dB)	Corrected Reading (dBm)	Limit (dBm)	Margin (dB)
3819.6	-48.62	V	10.36	2.73	-40.99	-13	-27.99
3819.6	-49.23	H	10.36	2.73	-41.6	-13	-28.60
326.4	-53.27	V	6.4	0.26	-47.13	-13	-34.13
608.2	-52.59	H	6.8	0.37	-46.16	-13	-33.16

#### Note:

- 1, The testing has been conformed to  $10 \times 1909.8 \text{ MHz} = 19,098 \text{ MHz}$
- 2, All other emissions more than 30 dB below the limit
- 3, GSM voice, GPRS and EGPRS mode were investigated. The results above show only the worse cases
- 4, X-Axis, Y-Axis and Z-Axis were investigated. The results above show only the worst case.



### UMTS-FDD Band V (Part 22H)

#### Low channel

Frequency (MHz)	Substituted level (dBm)	Polarity (H/V)	Antenna Gain Correction (dB)	Cable Loss (dB)	Corrected Reading (dBm)	Limit (dBm)	Margin (dB)
1652.8	-46.23	V	7.95	0.78	-39.06	-13	-26.06
1652.8	-46.41	H	7.95	0.78	-39.24	-13	-26.24
325.3	-52.37	V	6.4	0.26	-46.23	-13	-33.23
607.3	-53.16	H	6.8	0.37	-46.73	-13	-33.73

#### Middle channel

Frequency (MHz)	Substituted level (dBm)	Polarity (H/V)	Antenna Gain Correction (dB)	Cable Loss (dB)	Corrected Reading (dBm)	Limit (dBm)	Margin (dB)
1670	-46.28	V	7.95	0.78	-39.11	-13	-26.11
1670	-46.37	H	7.95	0.78	-39.2	-13	-26.20
326.8	-52.67	V	6.4	0.26	-46.53	-13	-33.53
604.7	-52.71	H	6.8	0.37	-46.28	-13	-33.28

#### High channel

Frequency (MHz)	Substituted level (dBm)	Polarity (H/V)	Antenna Gain Correction (dB)	Cable Loss (dB)	Corrected Reading (dBm)	Limit (dBm)	Margin (dB)
1693.2	-45.68	V	7.95	0.78	-38.51	-13	-25.51
1693.2	-46.21	H	7.95	0.78	-39.04	-13	-26.04
326.8	-52.73	V	6.4	0.26	-46.59	-13	-33.59
605.2	-53.18	H	6.8	0.37	-46.75	-13	-33.75

**Note:**

- 1, The testing has been conformed to  $10 \times 846.6 \text{ MHz} = 8,466 \text{ MHz}$
- 2, All other emissions more than 30 dB below the limit
- 3, RMC, HSUPA and HSDPA mode were investigated. The results above show only the worse cases
- 4, X-Axis, Y-Axis and Z-Axis were investigated. The results above show only the worst case.

## UMTS-FDD Band II (Part 24E)

### Low channel

Frequency (MHz)	Substituted level (dBm)	Polarity (H/V)	Antenna Gain Correction (dB)	Cable Loss (dB)	Corrected Reading (dBm)	Limit (dBm)	Margin (dB)
3704.8	-48.68	V	10.25	2.73	-41.16	-13	-28.16
3704.8	-48.79	H	10.25	2.73	-41.27	-13	-28.27
328.7	-53.65	V	6.4	0.26	-47.51	-13	-34.51
605.2	-53.49	H	6.8	0.37	-47.06	-13	-34.06

### Middle channel

Frequency (MHz)	Substituted level (dBm)	Polarity (H/V)	Antenna Gain Correction (dB)	Cable Loss (dB)	Corrected Reading (dBm)	Limit (dBm)	Margin (dB)
3760	-49.12	V	10.25	2.73	-41.6	-13	-28.60
3760	-49.37	H	10.25	2.73	-41.85	-13	-28.85
326.9	-53.26	V	6.4	0.26	-47.12	-13	-34.12
603.4	-53.18	H	6.8	0.37	-46.75	-13	-33.75

### High channel

Frequency (MHz)	Substituted level (dBm)	Polarity (H/V)	Antenna Gain Correction (dB)	Cable Loss (dB)	Corrected Reading (dBm)	Limit (dBm)	Margin (dB)
3815.2	-48.95	V	10.36	2.73	-41.32	-13	-28.32
3815.2	-49.06	H	10.36	2.73	-41.43	-13	-28.43
327.4	-53.72	V	6.4	0.26	-47.58	-13	-34.58
604.5	-53.26	H	6.8	0.37	-46.83	-13	-33.83

**Note:**

- 1, The testing has been conformed to  $10 \times 1907.6 \text{ MHz} = 19,076 \text{ MHz}$
- 2, All other emissions more than 30 dB below the limit
- 3, RMC, HSUPA and HSDPA mode were investigated. The results above show only the worse cases
- 4, X-Axis, Y-Axis and Z-Axis were investigated. The results above show only the worst case

## UMTS-FDD Band IV (Part 27)

### Low channel

Frequency (MHz)	Substituted level (dBm)	Polarity (H/V)	Antenna Gain Correction (dB)	Cable Loss (dB)	Corrected Reading (dBm)	Limit (dBm)	Margin (dB)
3424.8	-46.37	V	10.07	2.52	-38.82	-13	-25.82
3424.8	-48.16	H	10.07	2.52	-40.61	-13	-27.61
324.6	-57.34	V	6.4	0.26	-51.2	-13	-38.20
739.5	-52.67	H	7.1	0.42	-45.99	-13	-32.99

### Middle channel

Frequency (MHz)	Substituted level (dBm)	Polarity (H/V)	Antenna Gain Correction (dB)	Cable Loss (dB)	Corrected Reading (dBm)	Limit (dBm)	Margin (dB)
3480	-46.13	V	10.09	2.52	-38.56	-13	-25.56
3480	-46.79	H	10.09	2.52	-39.22	-13	-26.22
325.7	-56.38	V	6.4	0.26	-50.24	-13	-37.24
735.8	-53.27	H	7.1	0.42	-46.59	-13	-33.59

### High channel

Frequency (MHz)	Substituted level (dBm)	Polarity (H/V)	Antenna Gain Correction (dB)	Cable Loss (dB)	Corrected Reading (dBm)	Limit (dBm)	Margin (dB)
3505.2	-45.38	V	10.09	2.52	-37.81	-13	-24.81
3505.2	-45.59	H	10.09	2.52	-38.02	-13	-25.02
326.1	-57.28	V	6.4	0.26	-51.14	-13	-38.14
737.5	-51.94	H	7.1	0.42	-45.26	-13	-32.26

**Note:**

- 1, The testing has been conformed to  $10 \times 1752.6 \text{ MHz} = 17.526 \text{ MHz}$
- 2, All other emissions more than 30 dB below the limit
- 3, RMC, HSUPA and HSDPA mode were investigated. The results above show only the worse cases.
- 4, X-Axis, Y-Axis and Z-Axis were investigated. The results above show only the worst case.

## 6.7 Band Edge

Temperature	25°C
Relative Humidity	58%
Atmospheric Pressure	1016mbar
Test date :	November 16&17, 2016
Tested By :	Loren Luo

### Requirement(s):

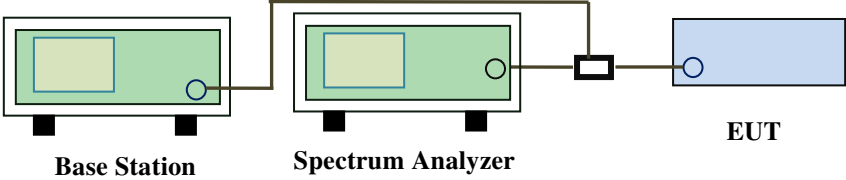
Spec	Item	Requirement	Applicable
§22.917(a) §24.238(a) § 27.53(h)	a)	The power of any emission outside of the authorized operating frequency ranges must be lower than the transmitter power (P) by a factor of at least $43 + 10 \log (P)$ dB.	<input checked="" type="checkbox"/>
Test setup	 <p>The diagram shows a Base Station (green box) connected to a Spectrum Analyzer (green box) and an EUT (blue box) via a power divider (black box). The Base Station and Spectrum Analyzer are connected to the power divider, which then splits the signal to the EUT.</p>		
Procedure	<ul style="list-style-type: none"> <li>- The EUT was connected to Spectrum Analyzer and Base Station via power divider.</li> <li>- The Band Edges of low and high channels for the highest RF powers were measured. Setting RBW as roughly BW/100.</li> </ul>		
Remark			
Result	<input checked="" type="checkbox"/> Pass <input type="checkbox"/> Fail		

Test Data     Yes       N/A

Test Plot     Yes (See below)       N/A

**GSM Voice:**

**Cellular Band (Part 22H) result**

Frequency (MHz)	Emission (dBm)	Limit (dBm)
823.998	-18.402	-13
849.019	-19.076	-13

**PCS Band (Part24E) result**

Frequency (MHz)	Emission (dBm)	Limit (dBm)
1849.982	-17.107	-13
1909.002	-16.899	-13

**GPRS:**

**Cellular Band (Part 22H) result**

Frequency (MHz)	Emission (dBm)	Limit (dBm)
823.996	-18.313	-13
849.018	-19.371	-13

**PCS Band (Part24E) result**

Frequency (MHz)	Emission (dBm)	Limit (dBm)
1849.997	-17.048	-13
1910.020	-18.046	-13

**EGPRS (MCS5):**

**Cellular Band (Part 22H) result**

Frequency (MHz)	Emission (dBm)	Limit (dBm)
823.998	-18.808	-13
849.024	-19.583	-13

**PCS Band (Part24E) result**

Frequency (MHz)	Emission (dBm)	Limit (dBm)
1849.979	-18.034	-13
1910.005	-17.833	-13

**RCM:**

**UMTS-FDD Band V (Part 22H)**

Frequency (MHz)	Emission (dBm)	Limit (dBm)
823.19	-30.419	-13
849.09	-29.557	-13

**UMTS-FDD Band II (Part 24E)**

Frequency (MHz)	Emission (dBm)	Limit (dBm)
1849.03	-27.538	-13
1911.00	-30.996	-13

**UMTS-FDD Band IV (Part 27)**

Frequency (MHz)	Emission (dBm)	Limit (dBm)
1709.13	-27.873	-13
1755.74	-30.854	-13