



Report No.: SZ12110149H01



HAC TEST REPORT

Issued to

Verykool USA Inc

For

Android phone

Model Name : S758
 Trade Name : verykool
 Brand Name : verykool
 FCC ID : WA6S758
 Standard : ANSI C 63.19:2007

HAC Level : H-Field: M3
 E-Field: M3

Test date : 2012-12-03
 Issue date : 2012-12-12

by
Shenzhen MORLAB Communication Technology Co., Ltd.



Tested by Samuel Peng
 Samuel Peng

Date 2012.12.12

Approved by

Date 2012.12.12

Review by

Li Lei

Li Lei

Date

2012.12.12



The report refers only to the sample tested and does not apply to the bulk. This report is issued in confidence to the client and it will be strictly treated as such by the Shenzhen MORLAB Communication Technology Co., Ltd. It may not be reproduced rather in its entirety or in part and it may not be used for adverting. The client to whom the report is issued may, however, show or send it, or a certified copy there of prepared by the Shenzhen MORLAB Telecommunication Co., Ltd to his customer. Supplier or others persons directly concerned. Shenzhen MORLAB Telecommunication Co., Ltd will not, without the consent of the client enter into any discussion of correspondence with any third party concerning the contents of the report. In the event of the improper use of the report, Shenzhen MORLAB Telecommunication Co., Ltd reserves the rights to withdraw it and to adopt any other remedies which may be appropriate.

Contents

1.1. Identification of the Responsible Testing Laboratory	3
1.2. Identification of the Responsible Testing Location	3
1.3. Accreditation Certificate.....	3
1.4. List of Test Equipments	3
2. TECHNICAL INFORMATION.....	4
2.1. Identification of Applicant.....	4
2.2. Identification of Manufacturer	4
2.3. Equipment Under Test (EUT)	4
2.3.1. Photographs of the EUT	4
2.3.2. Identification of all used EUTs	5
2.4. Applied Reference Documents	5
2.5. Test Environment/Conditions.....	6
2.6. Operational Conditions During Test.....	7
2.6.1. INTRODUCTION	7
2.6.2. ANSI/IEEE PC 63.19 PERFORMANCE CATEGORIES.....	8
2.6.3. Description of Test System.....	10
2.6.4. TEST PROCEDURE.....	14
2.6.5. SYSTEM CHECK.....	16
2.6.6. PROBE MODULATION FACTOR (PMF)	18
2.6.7. Uncertainty Estimation Table.....	20
2.6.8. OVERALL MEASUREMENT SUMMARY	21
2.6.9. TEST DATA	22
ANNEX A PHOTOGRAPHS OF THE EUT	84

1.1. Identification of the Responsible Testing Laboratory

Company Name: Shenzhen Morlab Communications Technology Co., Ltd.
 Department: Morlab Laboratory
 Address: 3/F, Electronic Testing Building, Shahe Road, Nanshan District, Shenzhen, 518055 P. R. China
 Responsible Test Lab Manager: Mr. Shu Luan
 Telephone: +86 755 86130268
 Facsimile: +86 755 86130218

1.2. Identification of the Responsible Testing Location

Name: Shenzhen Morlab Communications Technology Co., Ltd.
 Morlab Laboratory
 Address: 3/F, Electronic Testing Building, Shahe Road, Nanshan District, Shenzhen, 518055 P. R. China

1.3. Accreditation Certificate

Accredited Testing Laboratory: No. CNAS L3572

1.4. List of Test Equipments

No.	Instrument	Type	Cal. Date	Cal. Due
1	PC	Dell (Pentium IV 2.4GHz, SN:X10-23533)	(n.a)	(n.a)
2	Network Emulator	Rohde&Schwarz (CMU200, SN:105894)	2012-9-26	1year
3	Voltmeter	Keithley (2000, SN:1000572)	2012-9-26	1year
4	Signal Generator	Rohde&Schwarz (SMP_02)	2012-9-24	1year
5	Amplifier	Nucl udes (ALB216, SN:10800)	2012-9-24	1year
6	Power Meter	Agilent (E4416A, SN:MY45102093)	2012-5-07	1year
7	Power Sensor	Agilent (N8482A, SN:MY41091706)	2012-5-07	1year
8	Directional coupler	Giga-tronics(SN:1829112)	2012-9-24	1year
9	E-FIELD PROBE	SN: SN 41/08 EPH17	2012-10-06	1year
10	H-FIELD PROBE	SN: SN 41/08 HPH18	2012-10-06	1year
11	800-950 MHZ DIPOLE	SN: SN 36/08 DHA16	2012-10-06	1year
12	1700-2000 MHZ DIPOLE	SN: SN 36/08 DHB16	2012-10-06	1year
13	HAC holder	SN02_EPH02 (SN:SN_3608_SUPH16)	2012-9-24	2year



2. Technical Information

Note: the following data is based on the information by the applicant.

2.1. Identification of Applicant

Company Name: Verykool USA Inc
Address: 3636 Nobel Drive, Suite 325, San Diego, CA 92122 USA

2.2. Identification of Manufacturer

Company Name: Verykool Wireless Technology Ltd.
Address: Room 1701, Reward Building C, No.203, 2nd Section of WangJing, Li Ze Zhong Yuan, ChaoYang District, Beijing, P.R. of China 100102

2.3. Equipment Under Test (EUT)

Model Name: S758
Trade Name: verykool
Brand Name: verykool
Hardware Version: N/A
Software Version: N/A
Frequency Bands: GSM 850MHz; PCS 1900MHz;
WCDMA 850MHz; WCDMA 1700MHz; WCDMA 1900MHz
WIFI: 2412MHz-2462MHz
BT: 2402MHz-2480MHz
Modulation Mode: GSM:GMSK
WIFI802.11B: DSSS; WIFI802.11G: OFDM
WIFI 802.11N: OFDM; BT: GFSK/8-DPSK
Antenna type: Fixed Internal Antenna
Development Stage: Identical prototype
Battery Model: 553450AR
Battery specification: 1050mAh3.7V
GSM 850; channel 128, 190, 251, BT OFF, Wifi OFF
GSM 1900; channel 512, 661, 810, BT OFF, Wifi OFF
HAC Test WCDMA 850; channel 4132, 4182, 4233, BT OFF, Wifi OFF
Configurations: WCDMA 1700; channel 1312, 1412, 1513, BT OFF, Wifi OFF
WCDMA 1900; channel 9262, 9400, 9538, BT OFF, Wifi OFF

2.3.1. Photographs of the EUT

Please see for photographs of the EUT.

2.3.2. Identification of all used EUTs

The EUT identity consists of numerical and letter characters, the letter character indicates the test sample, and the following two numerical characters indicate the software version of the test sample.

EUT Identity	Hardware Version	Software Version
1#	N/A	N/A

2.4. Applied Reference Documents

Leading reference documents for testing:

No.	Identity	Document Title
1	ANSI C 63.19:2007	American National Standard Methods of Measurement of Compatibility between Wireless Communications Devices and Hearing Aids

Note: Test report, reference KDB 285076 documents.

2.5. Test Environment/Conditions

Normal Temperature (NT):	20 ... 25 °C
Relative Humidity:	30 ... 75 %
Air Pressure:	980 ... 1020 hPa
Test frequency:	GSM 850MHz /PCS 1900MHz;
Operation mode:	Call established
Power Level:	GSM 850 MHz Maximum output power(level 5) PCS 1900 MHz Maximum output power(level 0) WCDMA 850MHz Maximum output power (All up bits) WCDMA 1700MHz Maximum output power (All up bits) WCDMA 1900MHz Maximum output power (All up bits)

During HAC test, EUT is in Traffic Mode (Channel Allocated) at Normal Voltage Condition. A communication link is set up with a System Simulator (SS) by air link, and a call is established.

The Absolute Radio Frequency Channel Number (ARFCN) is allocated to 125, 190 and 251 respectively in the case of GSM 850 MHz, or to 512, 661 and 810 respectively in the case of PCS 1900 MHz. The EUT is commanded to operate at maximum transmitting power.

The EUT shall use its internal transmitter. The antenna(s), battery and accessories shall be those specified by the manufacturer. The EUT battery must be fully charged and checked periodically during the test to ascertain uniform power output. If a wireless link is used, the antenna connected to the output of the base station simulator shall be placed at least 50 cm away from the handset.

The signal transmitted by the simulator to the antenna feeding point shall be lower than the output power level of the handset by at least 35 dB.

Air-interface	Band (MHz)	Type	C63.19-2007 Tested	Simultaneous Transmissions Scenarios invoice (Not to be tested)	Reduced power	VOIP
GSM	850	Voice	Yes	Yes: WIFI or BT	N/A	N/A
	1900	Voice	Yes	Yes: WIFI or BT	N/A	N/A
	GPRS	Data	N/A	N/A	N/A	N/A
WCDMA	850	Voice	Yes	Yes: WIFI or BT	N/A	N/A
	1700	Voice	Yes	Yes: WIFI or BT	N/A	N/A
	1900	Voice	Yes	Yes: WIFI or BT	N/A	N/A
	HSDPA	Data	N/A	N/A	N/A	N/A
	HSUPA	Data	N/A	N/A	N/A	N/A
WIFI	2450	Data	N/A	Yes GSM or WCDMA	N/A	N/A
BT	2450	Data	N/A	Yes GSM or WCDMA	N/A	N/A

The volume is at the maximum value, and the backlight of the phone is turned off. The Manufacturer doesn't design HAC mode software on the EUT

2.6. Operational Conditions During Test

2.6.1. INTRODUCTION

On July 10, 2003, the Federal Communications Commission (FCC) adopted new rules requiring wireless manufacturers and service providers to provide digital wireless phones that are compatible with hearing aids. The FCC has modified the exemption for wireless phones under the Hearing Aid Compatibility Act of 1998 (HAC Act) in WT Docket 01-309 RM-8658 to extend the benefits of wireless telecommunications to individuals with hearing disabilities. These benefits encompass business, social and emergency communications, which increase the value of the wireless network for everyone. An estimated more than 10% of the population in the United States show signs of hearing impairment and of that fraction, almost 80% use hearing aids. Approximately 500 million people worldwide suffer from hearing loss.

Compatibility Tests involved:

The standard calls for wireless communications devices to be measured for:

- RF Electric-field emissions.
- RF Magnetic- field emissions.
- T-coil mode, magnetic-signal strength in the audio band.
- T-coil mode, magnetic-signal frequency response through the audio band.
- T-coil mode, magnetic-signal and noise articulation index.

The hearing aid must be measured for:

- RF immunity in microphone mode
- RF immunity in T-coil mode

In the following tests and results, this report includes the evaluation for a wireless communications device

2.6.2. ANSI/IEEE PC 63.19 PERFORMANCE CATEGORIES

4.3.2.1. RF EMISSIONS

The ANSI Standard presents performance requirements for acceptable interoperability of hearing with wireless communications devices. When these parameters are met, a hearing aid operates acceptably in close proximity to a wireless communications device.

850MHz Limit:

Category	AWF (dB)	Limits for E-Field Emission (V/m)	Limits for H-Field Emission (A/m)
M1	0	631.0 - 1122.0	1.91 - 3.39
	-5	473.2 - 841.4	1.43 - 2.54
M2	0	354.8 - 631.0	1.07 - 1.91
	-5	266.1 - 473.2	0.80 - 1.43
M3	0	199.5 - 354.8	0.6 - 1.07
	-5	149.6 - 266.1	0.45 - 0.80
M4	0	<199.5	<0.60
	-5	<149.6	<0.45

Hearing aid and WD near-field categories as defined in ANSI PC 63.19. During testing, the hearing aid must maintain an input-referenced interference level of less than 55dB a gain compression of less than 6dB.

1900MHz Limit:

Category	AWF (dB)	Limits for E-Field Emission (V/m)	Limits for H-Field Emission (A/m)
M1	0	199.5 - 354.8	0.6 - 1.07
	-5	149.6 - 266.1	0.45 - 0.8
M2	0	112.2 - 199.5	0.34 - 0.6
	-5	84.1 - 149.6	0.25 - 0.45
M3	0	63.1 - 112.2	0.19 - 0.34
	-5	47.3 - 84.1	0.15 - 0.25
M4	0	<63.1	<0.19
	-5	<47.3	<0.15

4.3.2.2. Articulation Weighing Factor (AWF)

Standard	Technology	AWF
T1/T1P1/3GPP	UMTS(WCDMA)	0
IS-95	CDMA	0
iden	GSM(22and 11Hz)	0
J-STD-007	GSM(217Hz)	-5

AWF has been developed from information presented to the committee regarding the interference potential of the various modulation types according to ANSI PC 63.19

2.6.3. Description of Test System

2.6.3.1. COMO HAC E-FIELD PROBE



Serial Number:	SN 41/08 EPH17
Frequency:	100MHz – 3GHz
Probe length:	330mm
Length of one dipole:	3.3mm
Maximum external diameter:	8mm
Probe extremity diameter:	6mm
Distance between dipoles/probe extremity:	3mm
Resistance of the three dipole (at the connector):	Dipole 1:R1=2.1807 MΩ Dipole 2:R1=2.0612 MΩ Dipole 3:R3=2.1892 MΩ
Connector (HIROSE series SR30)	6 wire male (Hirose SR30series)

CALIBRATION TEST EQUIPMENT

TYPE	IDENTIFICATION
Calibration bench	SATIMO AIR CALIBRATION SOFTWARE
Multimeter	Keithley 2000

MEASUREMENT PROCEDURE

Probe calibration is realized by using the waveguide method. The probe was inserted in a waveguide loading by a 50 load. By controlling the input power in the waveguide, we are able to create a know EField value in the waveguide. ,

Keithley configuration:

Rate = Medium; Filter =ON; RDGS=10; FILTER TYPE =MOVING AVERAGE; RANGE AUTO

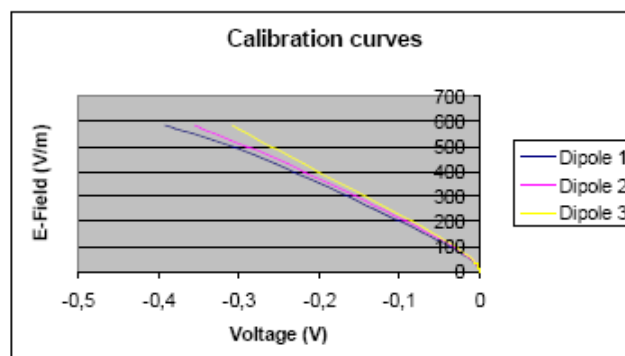

The following tables represent the calibration curves linearization by curve segment in CW signal.

2.6.3.2. COMO HAC H-FIELD PROBE



Serial Number:	SN 41/08 HPH18
Frequency:	100MHz – 3GHz
Probe length:	330mm
Length of one dipole:	3.3mm
Maximum external diameter:	8mm
Probe extremity diameter:	6mm
Distance between dipoles/probe extremity:	3mm
Resistance of the three dipole (at the connector) :	Dipole 1:R1=2.1650 MΩ Dipole 2:R1=2.2176 MΩ Dipole 3:R3=2.4084 MΩ
Connector (HIROSE series SR30)	6 wire male (Hirose SR30series)

CALIBRATION TEST EQUIPMENT

TYPE	IDENTIFICATION
Calibration bench	SATIMO AIR CALIBRATION SOFTWARE
Multimeter	Keithley 2000

MEASUREMENT PROCEDURE

Probe calibration is realized by using the waveguide method. The probe was inserted in a waveguide loading by a 50 load. By controlling the input power in the waveguide, we are able to create a know HField value in the waveguide.

Keithley configuration:

Rate = Medium; Filter =ON; RDGS=10; FILTER TYPE =MOVING AVERAGE; RANGE AUTO

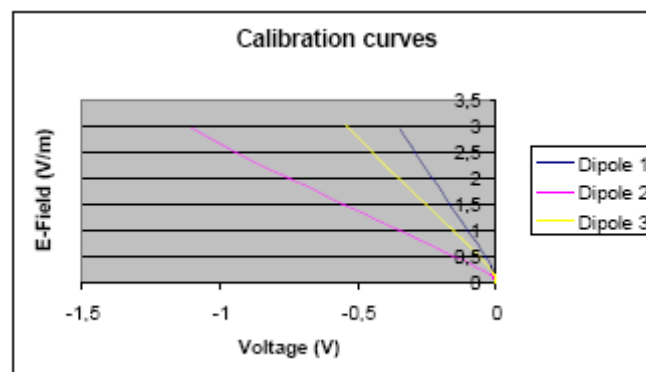

The following tables represent the calibration curves linearization by curve segment in CW signal.

2.6.3.3. COMOHAC T-COIL PROBE



Serial Number:	SN 39/08 TCP11
Dimensions:	6.55mm length*2.29mm diameter
DC resistance:	860.6Ω
Wire size:	51 AWG
Inductance:	132.1 mH at 1kHz
Sensitivity:	-60.22 dB (V/A/m) at 1kHz

SENSITIVITY

Probe coil sensitivity relative to sensitivity at 1000 Hz

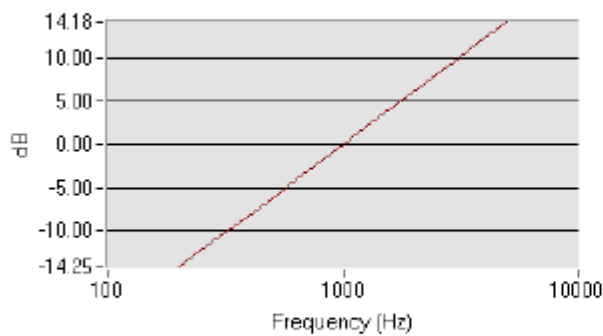

T-Coil probe sensitivity (dB V/(A/m))

Frequency (Hz)	H (dB (V/(A/m)))
200	-73,92940009
250	-72,01119983
315	-70,06378892
400	-67,88880017
500	-66,00059991
630	-64,07318901
800	-62,00820026
1000	-60,22
1250	-58,29179974
1600	-56,20760035
2000	-54,31940009
2500	-52,36119983
3150	-50,38378892
4000	-48,50880017
5000	-46,44059991

LINEARITY

Linearity = 0.27 dB

Power (dB) relative to 1 A/m	0	-10	-20	-30	-40	-50
H (dB (V/(A/m)))	0	-9,95	-19,95	-30	-39,9	-49,73

2.6.3.4. System Hardware

The HAC positioning ruler is used to position the phone properly with the regard to the position of the probe during a measurement. The positioning system is made of a dedicated frame that can be fixed on the table. The tip of the probe is positioned on a reference point located on the top of the positioning ruler. The distance between this reference point and the cross located on the ruler being known, the speaker of the phone is positioned on this cross in order to make sure both probe and phone are positioned properly.

During the measurement, the HAC ruler has to be removed so that it does not interfere with the measurement.

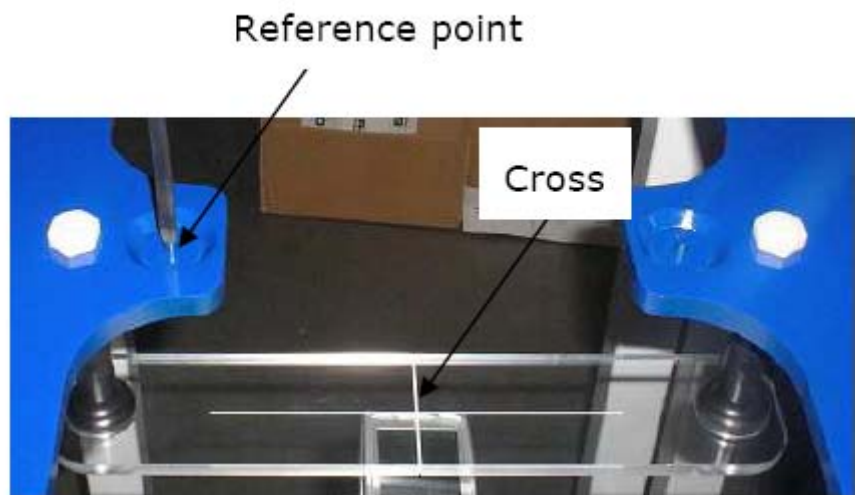

HAC positioning ruler

2.6.4. TEST PROCEDURE

2.6.4.1. RF EMISSIONS

Per ANSI C 63.19 2007:

Test Instructions

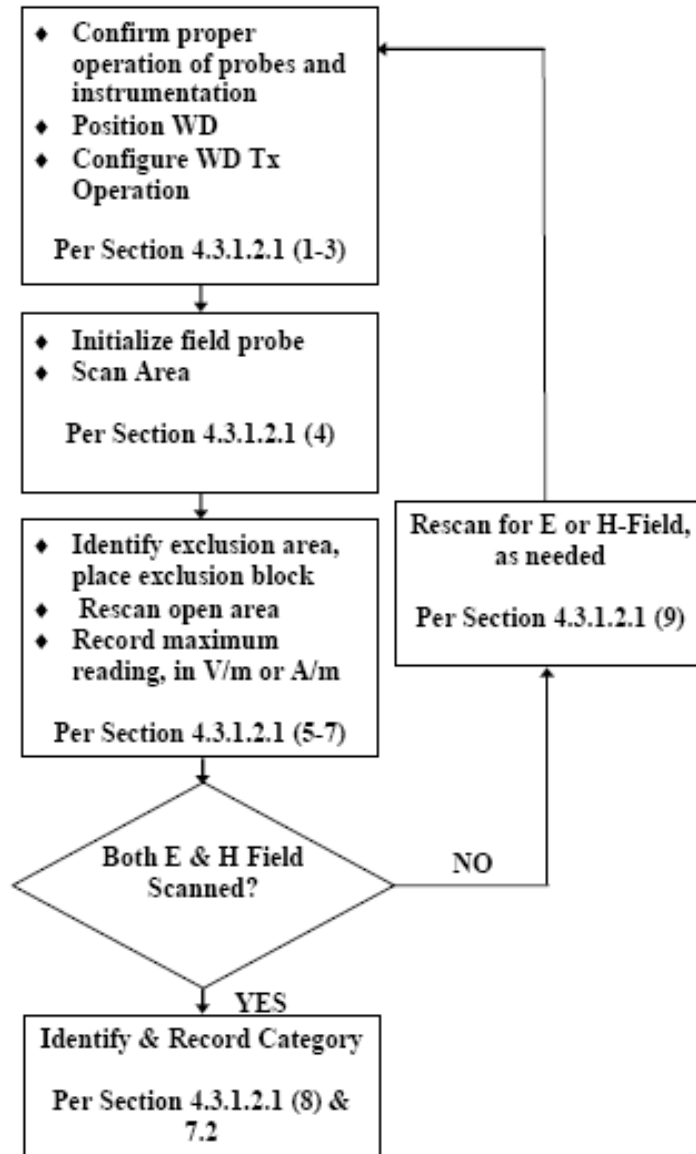

2.6.4.2. TEST Setup



WD reference and plane for RF emission measurements

4.3.4.3. RF Emission Test Procedure

The following illustrate a typical RF emissions test scan over a wireless communications device:

1. Proper operation of the field probe, probe measurement system, other instrumentation, and the positioning system was confirmed.
2. WD is positioned in its intended test position, acoustic output point of the device perpendicular to the field probe.
3. The WD operation for maximum rated RF output power was configured and confirmed with the base station simulator, at the test channel and other normal operating parameters as intended for the test. The battery was ensured to be fully charged before each test.
4. The center sub-grid was centered over the center of the acoustic output (also audio band magnetic output, if applicable). The WD audio output was positioned tangent (as physically possible) to the measurement plane.
5. A surface calibration was performed before each setup change to ensure repeatable spacing and proper maintenance of the measurement plane using the HAC Phantom.
6. The measurement system measured the field strength at the reference location.

2.6.5. SYSTEM CHECK

2.6.5.1. System Check Parameters

The input signal was an unmodulated continuous wave. The following points were taken into consideration in performing this check:

- Average Input Power $P = 100\text{mW RMS}$ (20dBm RMS) after adjustment for return loss
- The test fixture must meet the 2 wavelength separation criterion
- The proper measurement of the 1 cm probe to dipole separation, which is measured from top surface of the dipole to the calibration reference point of the sensor, defined by the probe manufacturer is shown in the following diagram:

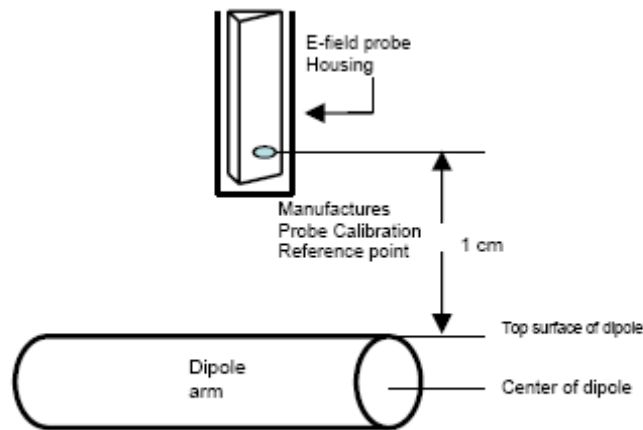

Figure 15
Separation Distance from Dipole to Field Probe

RF power was recorded using both an average reading meter and a peak reading meter. Readings of the probe are provided by the measurement system.

To assure proper operation of the near-field measurement probe the input power to the dipole shall be commensurate with the full rated output power of the wireless device (e.g. - for a cellular phone wireless device the average peak antenna input power will be on the order of 100mW (i.e. - 20dBm) RMS after adjustment for any mismatch.

2.6.5.2 Validation Procedure

A dipole antenna meeting the requirements given in PC63.19 was placed in the position normally occupied by the WD.

The length of the dipole was scanned with both E-field and H-field probes and the maximum values for each were recorded.

Using the near-field measurement system, scan the antenna over the radiating dipole and record the greatest field reading observed. Due to the nature of E-fields about free-space dipoles, the two E-field peaks measured over the dipole are averaged to compensate for non-parallelity of the setup see manufacturer method on dipole calibration certificates, Field strength measurements shall be made only when the probe is stationary.

RF power was recorded using both an average and a peak power reading meter.

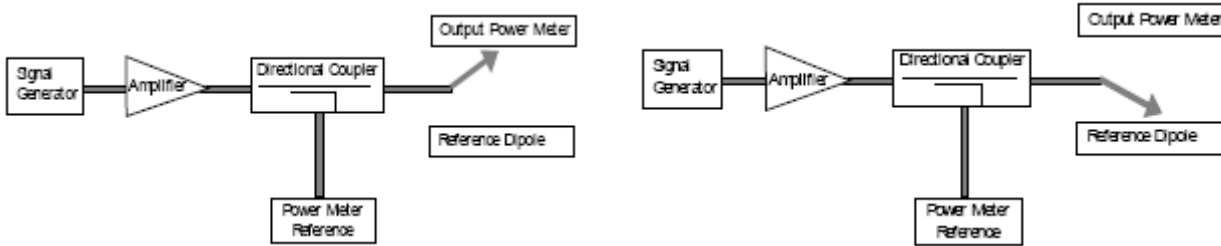

Setup for Desired Output Power to Dipole

Setup to Dipole

Using this setup configuration, the signal generator was adjusted for the desired output power (100mW) at a specified frequency. The reference power from the coupled port of the directional coupler is recorded. Next, the output cable is connected to the reference dipole,

2.6.5.3. Test System Validation

Validation Results (20dBm forward input power), System checks the specific test data please see page 49-56

Frequency	Input Power (dBm)	E-field Result (V/m)	Target Field (V/m)	Deviation (%)
850 MHz	20.0	196	205	-4.4
1900MHz	20.0	161.52	165	-2.1
Frequency	Input Power (dBm)	H-field Result (A/m)	Target Field (A/m)	Deviation (%)
850 MHz	20.0	0.429	0.448	-4.2
1900MHz	20.0	0.438	0.452	-3.1

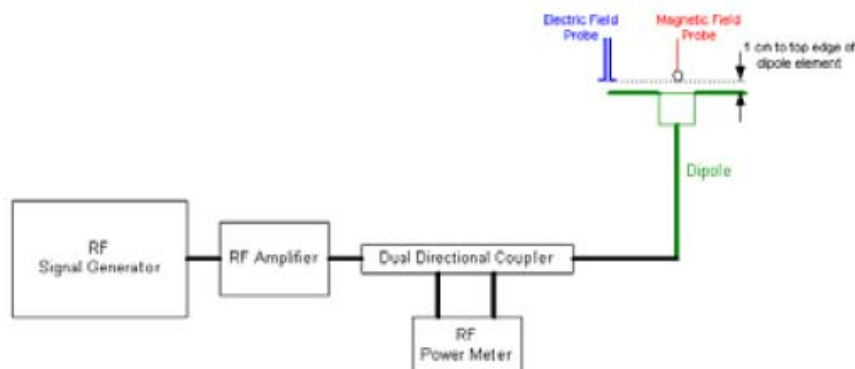

System Check Setup

2.6.6. PROBE MODULATION FACTOR (PMF)

The Probe Modulation Factor (PMF) is defined as the ratio of the field readings for a CW and a modulated signal with the equivalent Field Envelope Peak as defined in the Standard. The field level of the test signals shall be more than 10 dB above the ambient level and the noise floor of the instrumentation being used. The ratio of the CW reading to that taken with a modulated field shall be applied to the readings taken of modulated fields of the specified type.

All voice modes for this device have been investigated in this section of the report.

This was done using the following procedure:

1. Fixing the probe in a set location relative to a field generating device.
2. Illuminate the probe with a CW signal at the intended measurement frequency.
3. Record the reading of the probe measurement system of the CW signal.
4. Determine the level of the CW signal being used to drive the field generating device.
5. Substitute a signal using the same modulation as that used by the intended WD for the CW signal.
6. Set the peak amplitude during transmission of the modulated signal to equal the amplitude of the CW signal.
7. Record the reading of the probe measurement system of the modulated signal.
8. The ratio of the CW to modulated signal reading is the modulation factor.
9. Repeat 2~8 steps at intended measurement frequency for both E and H field probe.

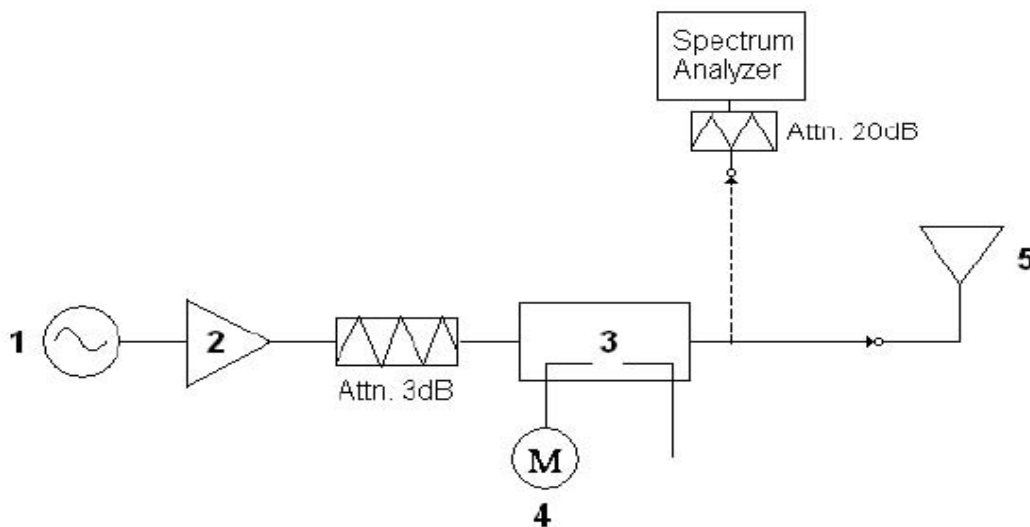

PMF measurement setup

PMF Summary:

Probe	Frequency (MHz)	Type of signal	E-Field (V/m)	PMF
E-Field Probe	835	GSM	74.48	2.81
		CW	209.25	
	1880	GSM	58.59	2.79
		CW	163.47	
H-Field Probe	835	GSM	0.159	2.83
		CW	0.451	
	1880	GSM	0.164	2.82
		CW	0.462	

Probe	Frequency (MHz)	Type of signal	E-Field (V/m)	PMF
E-Field Probe	835	WCDMA	233.64	0.87
		CW	203.27	
	1880	WCDMA	178.21	0.89
		CW	158.61	
H-Field Probe	835	WCDMA	0.491	0.90
		CW	0.442	
	1880	WCDMA	0.518	0.88
		CW	0.456	

Note: Modulation factor= E_{cw} / E_{mod} and similar for H.

2.6.7. Uncertainty Estimation Table

Error Description	Uncertainty value	Probe Dist.	Div	(Ci) E	(Ci) H	Std. Unc.(+-%)	
						E	H
Measurement System							
Probe calibration	6.00	N	1.000	1	1	6.00	6.00
Axial Isotropy	2.02	R	1.732	1	1	1.17	1.17
Sensor Displacement	14.30	R	1.732	1	0.217	8.26	1.79
Boundary effect	2.50	R	1.732	1	1	0.87	0.87
Phantom Boundary effect	6.89	R	1.732	1	0	3.52	0.00
Linearity	2.58	R	1.732	1	1	1.49	1.49
Scaling to PMR Calibration	9.02	N	1.000	1	1	9.02	9.02
System Detection Limit	1.30	R	1.732	1	1	0.75	0.75
Readout Electronics	0.25	R	1.732	1	1	0.14	0.14
Response Time	1.23	R	1.732	1	1	0.71	0.71
Integration Time	2.15	R	1.732	1	1	1.24	1.24
RF Ambient Conditions	2.03	R	1.732	1	1	1.17	1.17
RF Reflections	9.09	R	1.732	1	1	5.25	5.25
Probe positioner	0.63	N	1.000	1	0.71	0.63	0.45
Probe positioning	3.12	N	1.000	1	0.71	3.12	2.22
Extrapolation and Interpolation	1.18	R	1.732	1	1	0.68	0.68
Test sample Related							
Test sample positioning Vertical	2.73	R	1.732	1	0.71	1.58	1.12
Test sample positioning Lateral	1.19	R	1.732	1	1	0.69	0.69
Device Holder and Phantom	2.20	N	1.000	1	1	2.20	2.20
Power Drift	4.08	R	1.732	1	1	2.36	2.36
Phantom and Setup Related							
Phantom Thickness	2.00	N	1.000	1	0.6	2.00	1.20
Combined Std. Uncertainty(k=1)						16.18	13.25
Expanded Uncertainty on Power						32.35	26.50
Expanded Uncertainty on Field						16.18	13.25
Note for table 1. N-Normal 2. R-Rectangular 3. Div.- Divisor used to obtain standard uncertainty							

2.6.8. OVERALL MEASUREMENT SUMMARY

2.6.7.1 E-FIELD EMISSIONS

Band	Channel	M Rating	Output power (dBm)
GSM850	128	M3	32.22
GSM850	190	M3	32.17
GSM850	251	M3	32.14
GSM1900	512	M4	29.01
GSM1900	661	M4	29.06
GSM1900	810	M4	29.16
WCDMA850	4132	M4	23.15
WCDMA850	4182	M4	23.49
WCDMA850	4233	M4	23.29
WCDMA1700	1312	M4	22.54
WCDMA1700	1412	M4	22.85
WCDMA1700	1513	M4	22.70
WCDMA1900	9262	M4	22.67
WCDMA1900	9400	M4	22.72
WCDMA1900	9538	M4	22.59

2.6.7.2 H-FIELD EMISSIONS

Band	Channel	M Rating	Output power (dBm)
GSM850	128	M4	32.22
GSM850	190	M4	32.17
GSM850	251	M4	32.14
GSM1900	512	M4	29.01
GSM1900	661	M4	29.06
GSM1900	810	M3	29.16
WCDMA850	4132	M4	23.15
WCDMA850	4182	M4	23.49
WCDMA850	4233	M4	23.29
WCDMA1700	1312	M4	22.54
WCDMA1700	1412	M4	22.85
WCDMA1700	1513	M4	22.70
WCDMA1900	9262	M4	22.67
WCDMA1900	9400	M4	22.72
WCDMA1900	9538	M4	22.59

2.6.9. TEST DATA

<u>FREQUENCY</u>	<u>PARAMETERS</u>
<u>GSM850</u>	<p><u>Measurement 1:</u> Efield on Low Channel</p> <p><u>Measurement 2:</u> Hfield on Low Channel</p> <p><u>Measurement 3:</u> Efield on Middle Channel</p> <p><u>Measurement 4:</u> Hfield on Middle Channel</p> <p><u>Measurement 5:</u> Efield on High Channel</p> <p><u>Measurement 6:</u> Hfield on High Channel</p>
<u>GSM 1900</u>	<p><u>Measurement 7:</u> Efield on Low Channel</p> <p><u>Measurement 8:</u> Hfield on Low Channel</p> <p><u>Measurement 9:</u> Efield on Middle Channel</p> <p><u>Measurement 10:</u> Hfield on Middle Channel</p> <p><u>Measurement 11:</u> Efield on High Channel</p> <p><u>Measurement 12:</u> Hfield on High Channel</p>
<u>WCDMA 850</u>	<p><u>Measurement 13:</u> Efield on Low Channel</p> <p><u>Measurement 14:</u> Hfield on Low Channel</p> <p><u>Measurement 15:</u> Efield on Middle Channel</p> <p><u>Measurement 16:</u> Hfield on Middle Channel</p> <p><u>Measurement 17:</u> Efield on High Channel</p> <p><u>Measurement 18:</u> Hfield on High Channel</p>
<u>WCDMA 1700</u>	<p><u>Measurement 19:</u> Efield on Low Channel</p>

	<p><u>Measurement 20:</u> Hfield on Low Channel</p> <p><u>Measurement 21:</u> Efield on Middle Channel</p> <p><u>Measurement 22:</u> Hfield on Middle Channel</p> <p><u>Measurement 23:</u> Efield on High Channel</p> <p><u>Measurement 24:</u> Hfield on High Channel</p>
<u>WCDMA 1900</u>	<p><u>Measurement 25:</u> Efield on Low Channel</p> <p><u>Measurement 26:</u> Hfield on Low Channel</p> <p><u>Measurement 27:</u> Efield on Middle Channel</p> <p><u>Measurement 28:</u> Hfield on Middle Channel</p> <p><u>Measurement 29:</u> Efield on High Channel</p> <p><u>Measurement 30:</u> Hfield on High Channel</p>

MEASUREMENT 1

A. Experimental conditions.

Grid size (mm x mm)	50.0, 50.0
Step (mm)	5
Band	GSM850
Channel	Low
Signal	TDMA
Date of measurement	3/12/2012

B. HAC Measurement Results

Lower Band (Channel 128):

Frequency (MHz): 824.200000

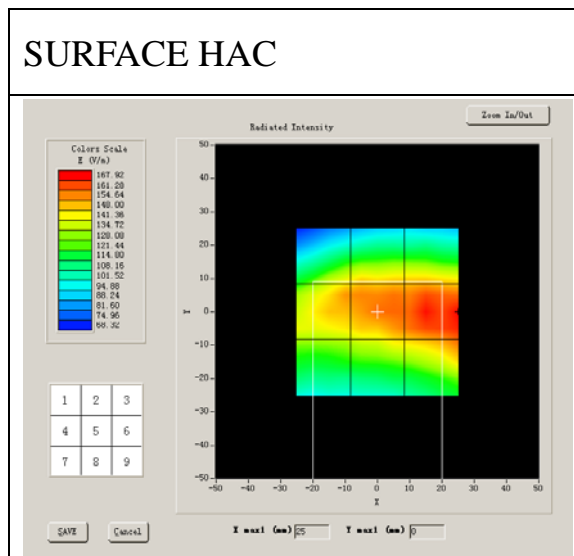

Probe Modulation Factor = 2.810000

Maximum value of total field = 158.58 V/m

Hearing Aid Near-Field Category: M3 (AWF -5 dB)

E in V/m

Grid 1: 141.47	Grid 2: 145.09	Grid 3: 145.45
Grid 4: 154.11	Grid 5: 158.58	Grid 6: 168.20
Grid 7: 136.04	Grid 8: 147.73	Grid 9: 159.48

MEASUREMENT 2

A. Experimental conditions.

Grid size (mm x mm)	50.0, 50.0
Step (mm)	5
Band	GSM850
Channel	Low
Signal	TDMA
Date of measurement	3/12/2012

B. HAC Measurement Results

Lower Band (Channel 128):

Frequency (MHz): 824.200000

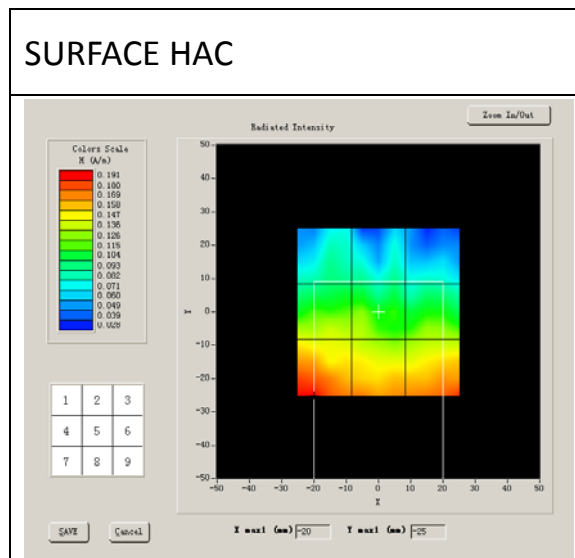

Probe Modulation Factor = 2.810000

Maximum value of total field = 0.14 A/m

Hearing Aid Near-Field Category: M4 (AWF -5 dB)

H in A/m

Grid 1: 0.09	Grid 2: 0.09	Grid 3: 0.08
Grid 4: 0.14	Grid 5: 0.13	Grid 6: 0.13
Grid 7: 0.19	Grid 8: 0.17	Grid 9: 0.18

MEASUREMENT 3

A. Experimental conditions.

Grid size (mm x mm)	50.0, 50.0
Step (mm)	5
Band	GSM850
Channel	Middle
Signal	TDMA
Date of measurement	3/12/2012

B. HAC Measurement Results

Middle Band (Channel 189):

Frequency (MHz): 836.400000

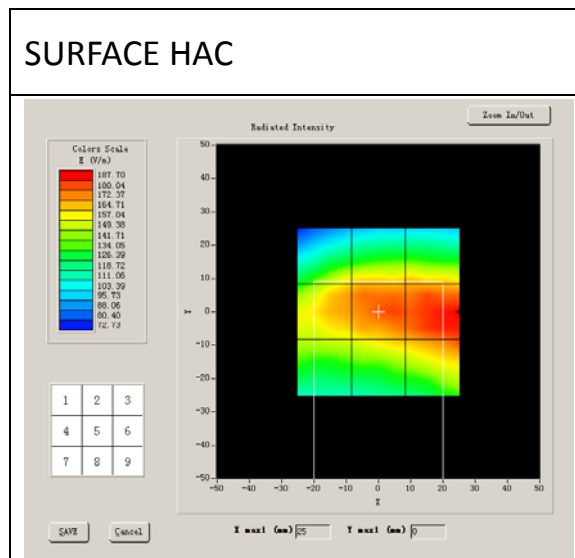

Probe Modulation Factor = 2.810000

Maximum value of total field = 181.20 V/m

Hearing Aid Near-Field Category: M3 (AWF -5 dB)

E in V/m

Grid 1: 158.19	Grid 2: 163.07	Grid 3: 163.77
Grid 4: 171.92	Grid 5: 181.20	Grid 6: 188.16
Grid 7: 155.01	Grid 8: 167.50	Grid 9: 180.94

MEASUREMENT 4

A. Experimental conditions.

Grid size (mm x mm)	50.0, 50.0
Step (mm)	5
Band	GSM850
Channel	Middle
Signal	TDMA
Date of measurement	3/12/2012

B. HAC Measurement Results

Middle Band (Channel 189):

Frequency (MHz): 836.400000

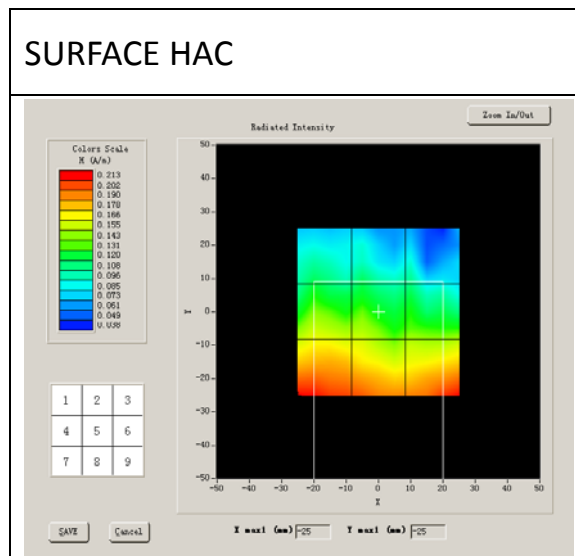

Probe Modulation Factor = 2.810000

Maximum value of total field = 0.16 A/m

Hearing Aid Near-Field Category: M4 (AWF -5 dB)

H in A/m

Grid 1: 0.11	Grid 2: 0.11	Grid 3: 0.10
Grid 4: 0.16	Grid 5: 0.15	Grid 6: 0.14
Grid 7: 0.21	Grid 8: 0.20	Grid 9: 0.21

MEASUREMENT 5

A. Experimental conditions.

Grid size (mm x mm)	50.0, 50.0
Step (mm)	5
Band	GSM850
Channel	High
Signal	TDMA
Date of measurement	3/12/2012

B. HAC Measurement Results

Higher Band (Channel 250):

Frequency (MHz): 848.600000

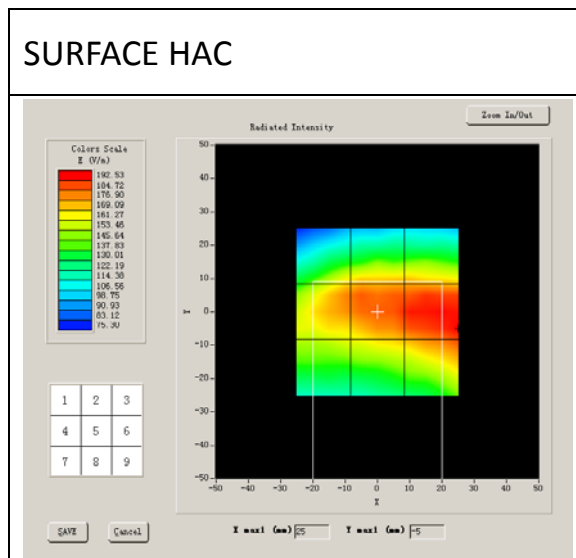

Probe Modulation Factor = 2.810000

Maximum value of total field = 188.98 V/m

Hearing Aid Near-Field Category: M3 (AWF -5 dB)

E in V/m

Grid 1: 163.01	Grid 2: 167.71	Grid 3: 167.77
Grid 4: 180.79	Grid 5: 188.98	Grid 6: 192.96
Grid 7: 158.93	Grid 8: 172.27	Grid 9: 186.51

MEASUREMENT 6

A. Experimental conditions.

Grid size (mm x mm)	50.0, 50.0
Step (mm)	5
Band	GSM850
Channel	High
Signal	TDMA
Date of measurement	3/12/2012

B. HAC Measurement Results

Higher Band (Channel 250):

Frequency (MHz): 848.600000

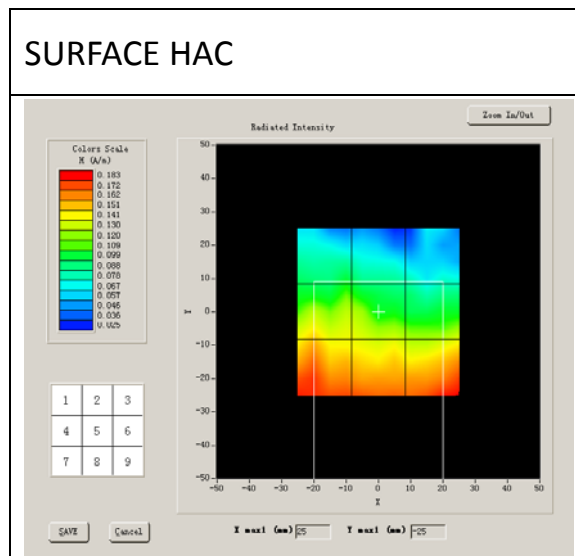

Probe Modulation Factor = 2.810000

Maximum value of total field = 0.15 A/m

Hearing Aid Near-Field Category: M4 (AWF -5 dB)

H in A/m

Grid 1: 0.10	Grid 2: 0.09	Grid 3: 0.08
Grid 4: 0.15	Grid 5: 0.14	Grid 6: 0.13
Grid 7: 0.18	Grid 8: 0.17	Grid 9: 0.18

MEASUREMENT 7

A. Experimental conditions.

Grid size (mm x mm)	50.0, 50.0
Step (mm)	5
Band	GSM1900
Channel	Low
Signal	TDMA
Date of measurement	3/12/2012

B. HAC Measurement Results

Lower Band (Channel 513):

Frequency (MHz): 1850.400000

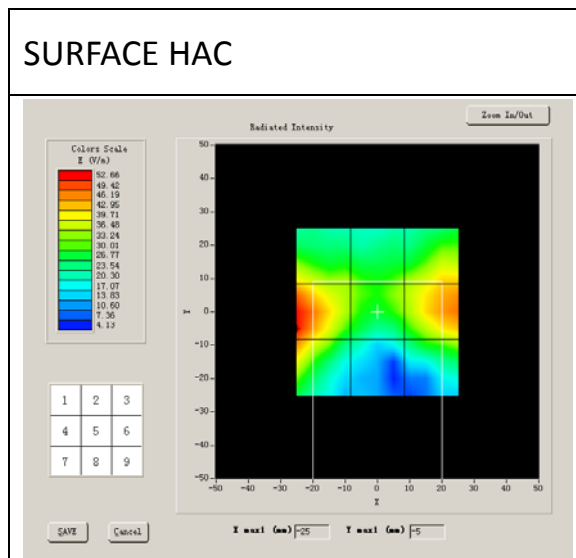

Probe Modulation Factor = 2.810000

Maximum value of total field = 47.26 V/m

Hearing Aid Near-Field Category: M4 (AWF -5 dB)

E in V/m

Grid 1: 39.04	Grid 2: 33.51	Grid 3: 41.52
Grid 4: 53.27	Grid 5: 35.39	Grid 6: 47.26
Grid 7: 48.70	Grid 8: 24.92	Grid 9: 37.45

MEASUREMENT 8

A. Experimental conditions.

Grid size (mm x mm)	50.0, 50.0
Step (mm)	5
Band	GSM1900
Channel	Low
Signal	TDMA
Date of measurement	3/12/2012

B. HAC Measurement Results

Lower Band (Channel 513):

Frequency (MHz): 1850.400000

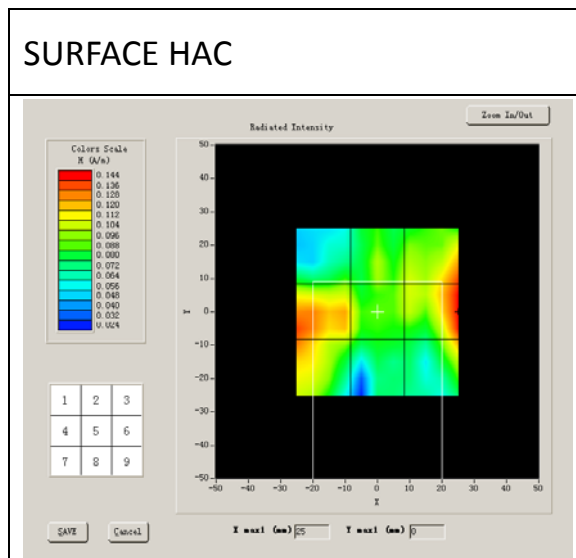

Probe Modulation Factor = 2.810000

Maximum value of total field = 0.14 A/m

Hearing Aid Near-Field Category: M4 (AWF -5 dB)

H in A/m

Grid 1: 0.09	Grid 2: 0.10	Grid 3: 0.14
Grid 4: 0.14	Grid 5: 0.10	Grid 6: 0.14
Grid 7: 0.13	Grid 8: 0.09	Grid 9: 0.13

MEASUREMENT 9

A. Experimental conditions.

Grid size (mm x mm)	50.0, 50.0
Step (mm)	5
Band	GSM1900
Channel	Middle
Signal	TDMA
Date of measurement	3/12/2012

B. HAC Measurement Results

Middle Band (Channel 661):

Frequency (MHz): 1880.000000

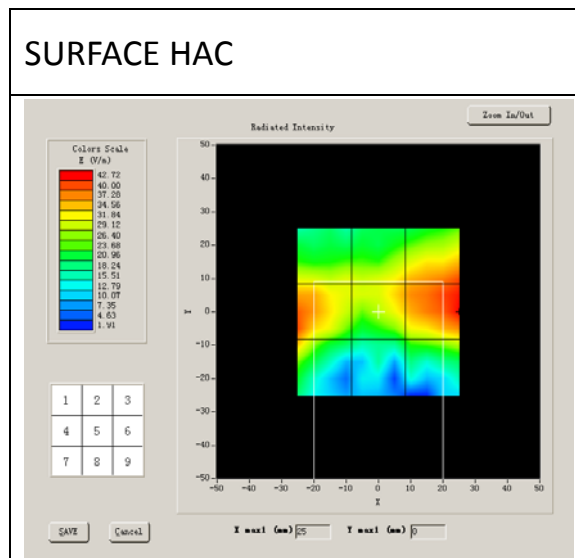

Probe Modulation Factor = 2.810000

Maximum value of total field = 40.31 V/m

Hearing Aid Near-Field Category: M4 (AWF -5 dB)

E in V/m

Grid 1: 30.20	Grid 2: 34.38	Grid 3: 39.87
Grid 4: 40.31	Grid 5: 36.31	Grid 6: 42.94
Grid 7: 36.85	Grid 8: 25.75	Grid 9: 31.77

MEASUREMENT 10

A. Experimental conditions.

Grid size (mm x mm)	50.0, 50.0
Step (mm)	5
Band	GSM1900
Channel	Middle
Signal	TDMA
Date of measurement	3/12/2012

B. HAC Measurement Results

Middle Band (Channel 661):

Frequency (MHz): 1880.000000

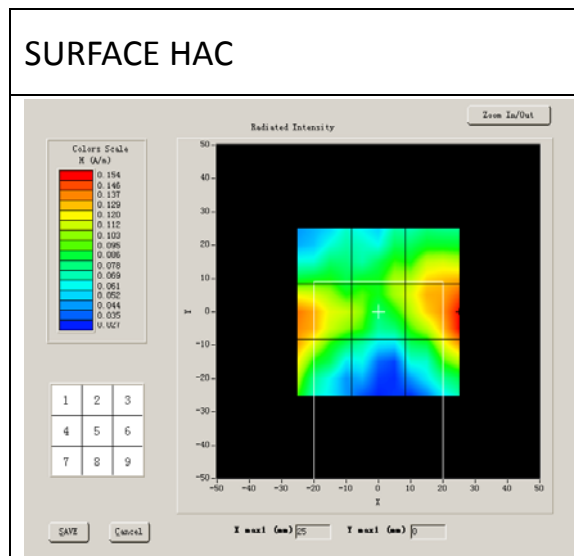

Probe Modulation Factor = 2.810000

Maximum value of total field = 0.14 A/m

Hearing Aid Near-Field Category: M4 (AWF -5 dB)

H in A/m

Grid 1: 0.09	Grid 2: 0.11	Grid 3: 0.13
Grid 4: 0.14	Grid 5: 0.11	Grid 6: 0.16
Grid 7: 0.13	Grid 8: 0.09	Grid 9: 0.14

MEASUREMENT 11

A. Experimental conditions.

Grid size (mm x mm)	50.0, 50.0
Step (mm)	5
Band	GSM1900
Channel	High
Signal	TDMA
Date of measurement	3/12/2012

B. HAC Measurement Results

Higher Band (Channel 809):

Frequency (MHz): 1909.600000

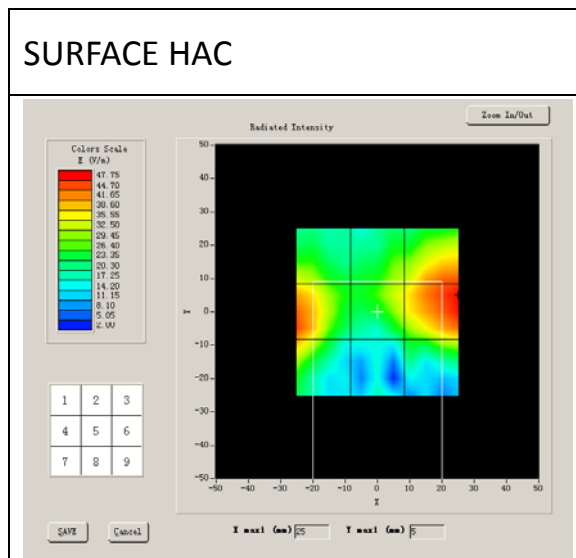

Probe Modulation Factor = 2.810000

Maximum value of total field = 45.16 V/m

Hearing Aid Near-Field Category: M4 (AWF -5 dB)

E in V/m

Grid 1: 32.89	Grid 2: 32.00	Grid 3: 43.75
Grid 4: 45.16	Grid 5: 36.00	Grid 6: 47.90
Grid 7: 41.40	Grid 8: 24.95	Grid 9: 35.71

MEASUREMENT 12

A. Experimental conditions.

Grid size (mm x mm)	50.0, 50.0
Step (mm)	5
Band	GSM1900
Channel	High
Signal	TDMA
Date of measurement	3/12/2012

B. HAC Measurement Results

Higher Band (Channel 809):

Frequency (MHz): 1909.600000

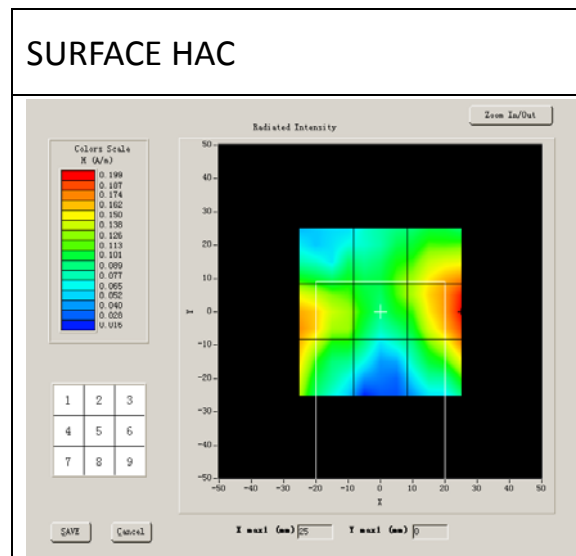

Probe Modulation Factor = 2.810000

Maximum value of total field = 0.17 A/m

Hearing Aid Near-Field Category: M3 (AWF -5 dB)

H in A/m

Grid 1: 0.11	Grid 2: 0.13	Grid 3: 0.17
Grid 4: 0.17	Grid 5: 0.13	Grid 6: 0.20
Grid 7: 0.17	Grid 8: 0.10	Grid 9: 0.18

MEASUREMENT 13

A. Experimental conditions.

Grid size (mm x mm)	50.0, 50.0
Step (mm)	5
Band	WCDMA 850
Channel	Low
Signal	CDMA
Date of measurement	3/12/2012

B. HAC Measurement Results

Frequency (MHz): 824.000000

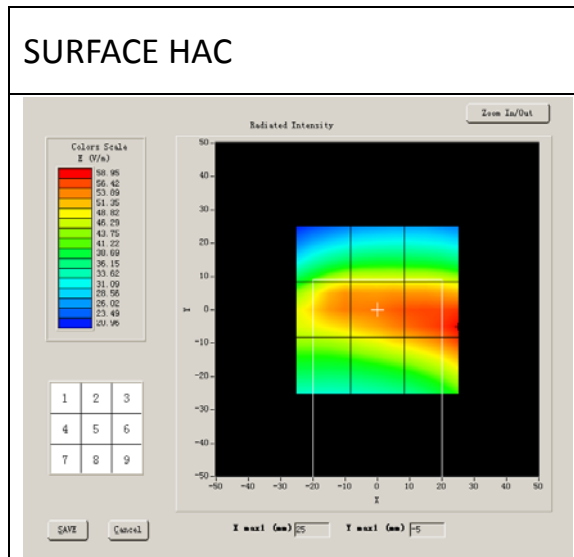

Probe Modulation Factor = 1.000000

Maximum value of total field = 56.24 V/m

Hearing Aid Near-Field Category: M4 (AWF 0 dB)

E in V/m

Grid 1: 46.36	Grid 2: 46.60	Grid 3: 46.35
Grid 4: 54.69	Grid 5: 56.24	Grid 6: 58.95
Grid 7: 47.81	Grid 8: 52.36	Grid 9: 57.83

MEASUREMENT 14

A. Experimental conditions.

Grid size (mm x mm)	50.0, 50.0
Step (mm)	5
Band	WCDMA 850
Channel	Low
Signal	CDMA
Date of measurement	3/12/2012

B. HAC Measurement Results

Frequency (MHz): 824.000000

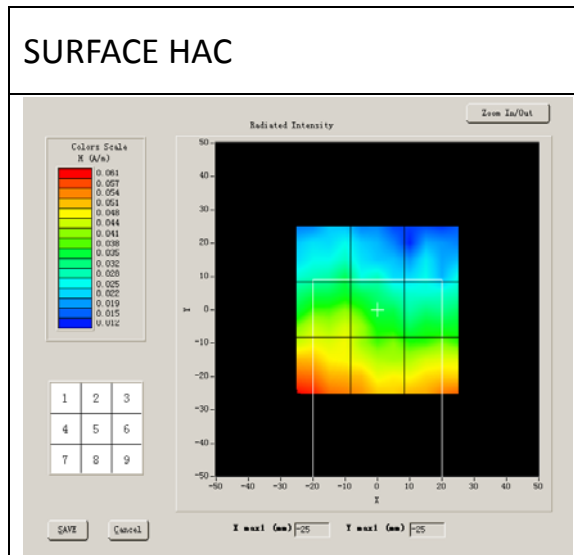

Probe Modulation Factor = 1.000000

Maximum value of total field = 0.05 A/m

Hearing Aid Near-Field Category: M4 (AWF 0 dB)

H in A/m

Grid 1: 0.03	Grid 2: 0.03	Grid 3: 0.03
Grid 4: 0.05	Grid 5: 0.04	Grid 6: 0.04
Grid 7: 0.06	Grid 8: 0.05	Grid 9: 0.06

MEASUREMENT 15

A. Experimental conditions.

Grid size (mm x mm)	50.0, 50.0
Step (mm)	5
Band	WCDMA 850
Channel	Middle
Signal	CDMA
Date of measurement	3/12/2012

B. HAC Measurement Results

Frequency (MHz): 835.000000

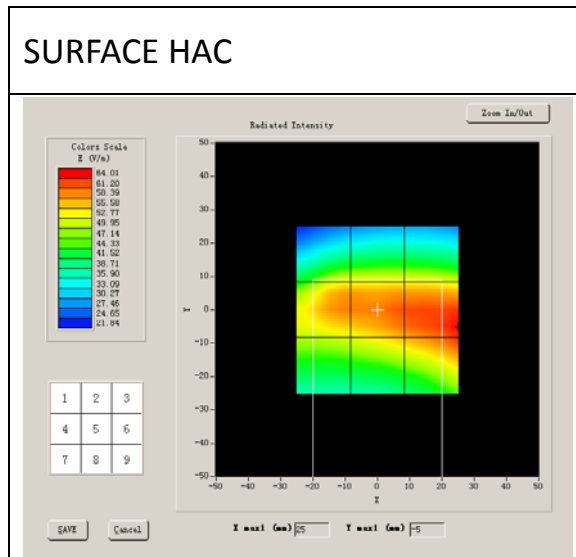

Probe Modulation Factor = 1.000000

Maximum value of total field = 61.06 V/m

Hearing Aid Near-Field Category: M4 (AWF 0 dB)

E in V/m

Grid 1: 49.77	Grid 2: 50.37	Grid 3: 49.98
Grid 4: 59.05	Grid 5: 61.06	Grid 6: 64.01
Grid 7: 51.69	Grid 8: 56.94	Grid 9: 62.82

MEASUREMENT 16

A. Experimental conditions.

Grid size (mm x mm)	50.0, 50.0
Step (mm)	5
Band	WCDMA 850
Channel	Middle
Signal	CDMA
Date of measurement	3/12/2012

B. HAC Measurement Results

Frequency (MHz): 835.000000

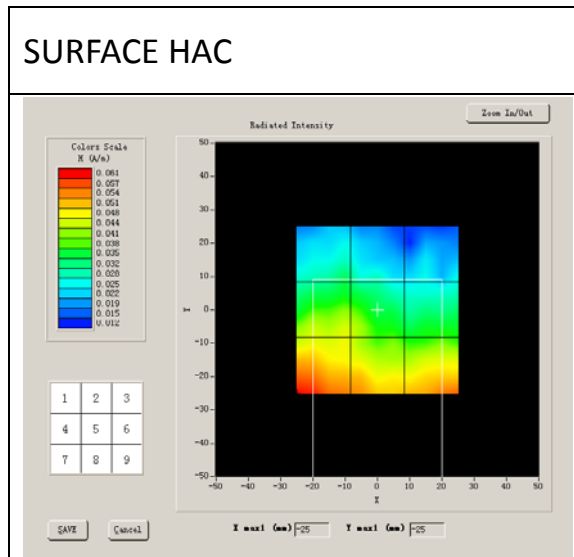

Probe Modulation Factor = 1.000000

Maximum value of total field = 0.08 A/m

Hearing Aid Near-Field Category: M4 (AWF 0 dB)

H in A/m

Grid 1: 0.04	Grid 2: 0.07	Grid 3: 0.08
Grid 4: 0.06	Grid 5: 0.01	Grid 6: 0.00
Grid 7: 0.07	Grid 8: 0.07	Grid 9: 0.07

MEASUREMENT 17

A. Experimental conditions.

Grid size (mm x mm)	50.0, 50.0
Step (mm)	5
Band	WCDMA 850
Channel	High
Signal	CDMA
Date of measurement	3/12/2012

B. HAC Measurement Results

Frequency (MHz): 0.000000

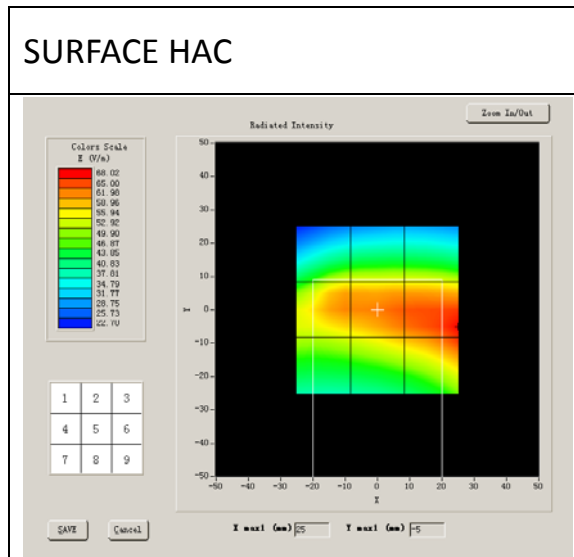

Probe Modulation Factor = 1.000000

Maximum value of total field = 64.52 V/m

Hearing Aid Near-Field Category: M4 (AWF 0 dB)

E in V/m

Grid 1: 52.45	Grid 2: 53.01	Grid 3: 52.81
Grid 4: 62.30	Grid 5: 64.52	Grid 6: 68.02
Grid 7: 54.70	Grid 8: 60.21	Grid 9: 66.87

MEASUREMENT 18

A. Experimental conditions.

Grid size (mm x mm)	50.0, 50.0
Step (mm)	5
Band	WCDMA 850
Channel	High
Signal	CDMA
Date of measurement	3/12/2012

B. HAC Measurement Results

Frequency (MHz): 0.000000

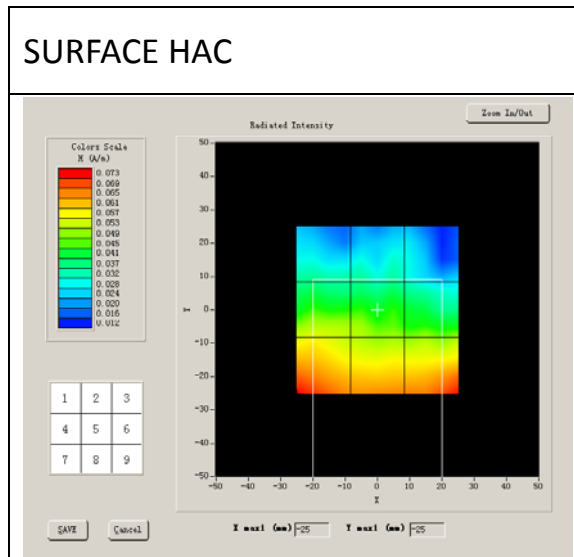

Probe Modulation Factor = 1.000000

Maximum value of total field = 0.05 A/m

Hearing Aid Near-Field Category: M4 (AWF 0 dB)

H in A/m

Grid 1: 0.03	Grid 2: 0.03	Grid 3: 0.03
Grid 4: 0.05	Grid 5: 0.05	Grid 6: 0.05
Grid 7: 0.07	Grid 8: 0.07	Grid 9: 0.07

MEASUREMENT 19

A. Experimental conditions.

Grid size (mm x mm)	50.0, 50.0
Step (mm)	5
Band	WCDMA 1700
Channel	Low
Signal	CDMA
Date of measurement	3/12/2012

B. HAC Measurement Results

Lower Band (Channel 1312):

Frequency (MHz): 1710.000000

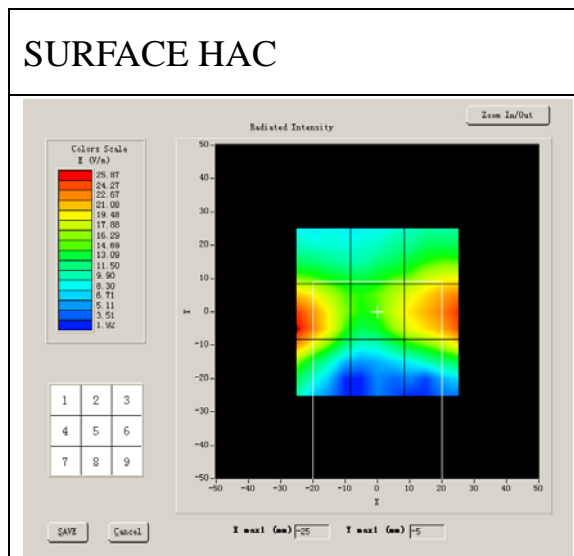

Probe Modulation Factor = 1.000000

Maximum value of total field = 26.63 V/m

Hearing Aid Near-Field Category: M4 (AWF 0 dB)

E in V/m

Grid 1: 16.15	Grid 2: 15.89	Grid 3: 19.38
Grid 4: 25.94	Grid 5: 19.51	Grid 6: 26.63
Grid 7: 24.32	Grid 8: 16.17	Grid 9: 21.75

MEASUREMENT 20

A. Experimental conditions.

Grid size (mm x mm)	50.0, 50.0
Step (mm)	5
Band	WCDMA 1700
Channel	Low
Signal	CDMA
Date of measurement	3/12/2012

B. HAC Measurement Results

Lower Band (Channel 1312):

Frequency (MHz): 1710.000000

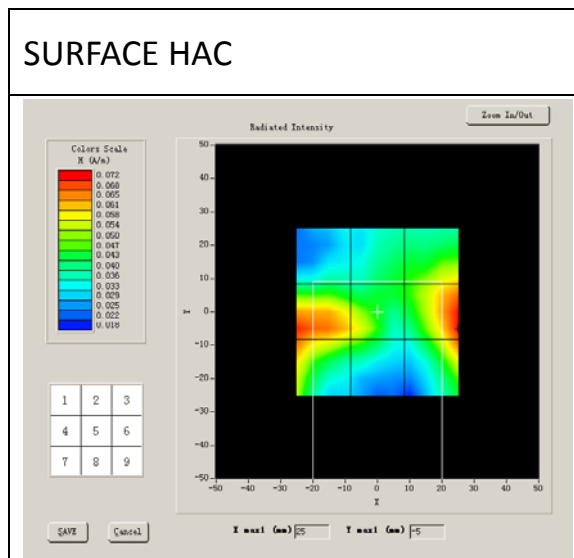

Probe Modulation Factor = 1.000000

Maximum value of total field = 0.07 A/m

Hearing Aid Near-Field Category: M4 (AWF 0 dB)

H in A/m

Grid 1: 0.06	Grid 2: 0.06	Grid 3: 0.07
Grid 4: 0.08	Grid 5: 0.07	Grid 6: 0.08
Grid 7: 0.07	Grid 8: 0.04	Grid 9: 0.08

MEASUREMENT 21

A. Experimental conditions.

Grid size (mm x mm)	50.0, 50.0
Step (mm)	5
Band	WCDMA 1700
Channel	Middle
Signal	CDMA
Date of measurement	3/12/2012

B. HAC Measurement Results

Middle Band (Channel 1412):

Frequency (MHz): 1740.000000

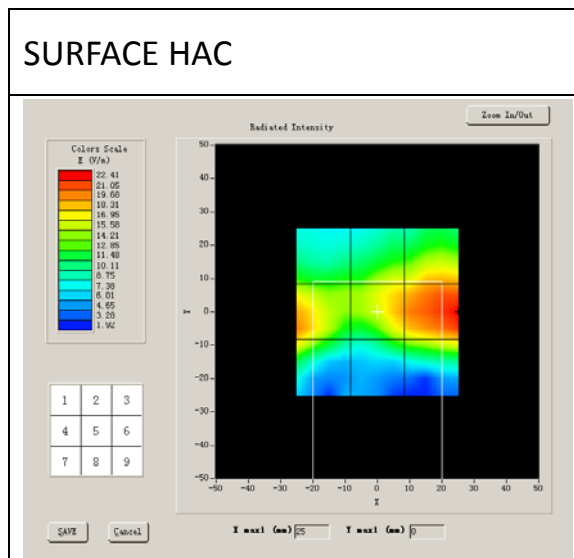

Probe Modulation Factor = 1.000000

Maximum value of total field = 20.14 V/m

Hearing Aid Near-Field Category: M4 (AWF 0 dB)

E in V/m

Grid 1: 16.51	Grid 2: 16.77	Grid 3: 19.21
Grid 4: 20.14	Grid 5: 19.15	Grid 6: 23.52
Grid 7: 19.53	Grid 8: 17.63	Grid 9: 21.14

MEASUREMENT 22

A. Experimental conditions.

Grid size (mm x mm)	50.0, 50.0
Step (mm)	5
Band	WCDMA 1700
Channel	Middle
Signal	CDMA
Date of measurement	3/12/2012

B. HAC Measurement Results

Middle Band (Channel 1412):

Frequency (MHz): 1740.000000

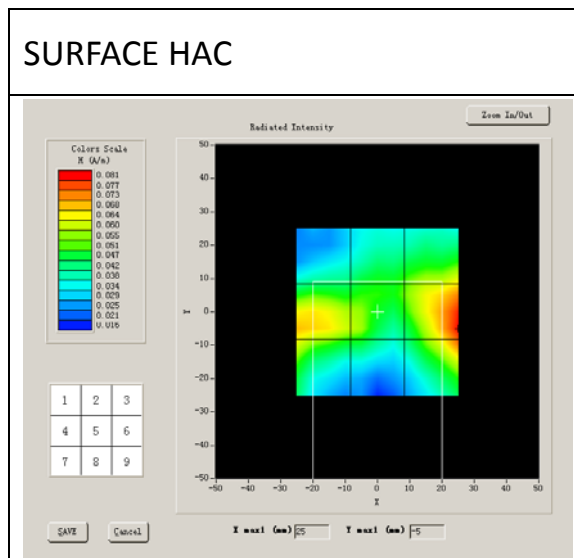

Probe Modulation Factor = 1.000000

Maximum value of total field = 0.10 A/m

Hearing Aid Near-Field Category: M4 (AWF 0 dB)

H in A/m

Grid 1: 0.07	Grid 2: 0.05	Grid 3: 0.08
Grid 4: 0.10	Grid 5: 0.06	Grid 6: 0.09
Grid 7: 0.08	Grid 8: 0.05	Grid 9: 0.09

MEASUREMENT 23

A. Experimental conditions.

Grid size (mm x mm)	50.0, 50.0
Step (mm)	5
Band	WCDMA 1700
Channel	High
Signal	CDMA
Date of measurement	3/12/2012

B. HAC Measurement Results

Higher Band (Channel 1513):

Frequency (MHz): 1770.000000

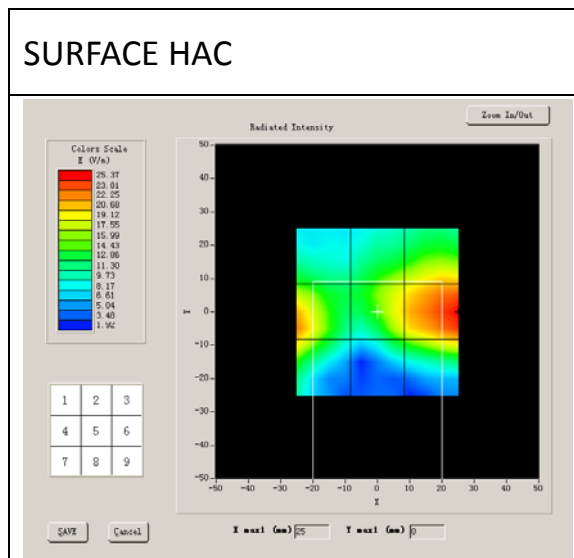

Probe Modulation Factor = 1.000000

Maximum value of total field = 23.63 V/m

Hearing Aid Near-Field Category: M4 (AWF 0 dB)

E in V/m

Grid 1: 15.74	Grid 2: 18.74	Grid 3: 21.52
Grid 4: 23.63	Grid 5: 20.60	Grid 6: 24.63
Grid 7: 19.52	Grid 8: 17.53	Grid 9: 20.51

MEASUREMENT 24

A. Experimental conditions.

Grid size (mm x mm)	50.0, 50.0
Step (mm)	5
Band	WCDMA 1700
Channel	High
Signal	CDMA
Date of measurement	3/12/2012

B. HAC Measurement Results

Higher Band (Channel 1513):

Frequency (MHz): 1770.000000

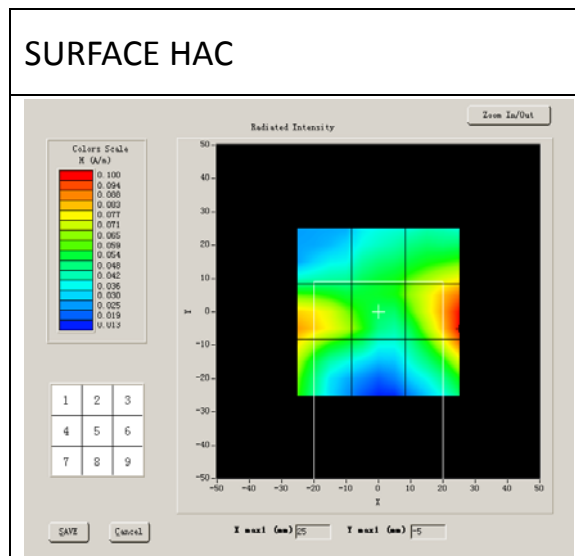

Probe Modulation Factor = 1.000000

Maximum value of total field = 0.09 A/m

Hearing Aid Near-Field Category: M4 (AWF 0 dB)

H in A/m

Grid 1: 0.06	Grid 2: 0.04	Grid 3: 0.08
Grid 4: 0.09	Grid 5: 0.07	Grid 6: 0.10
Grid 7: 0.08	Grid 8: 0.05	Grid 9: 0.09

MEASUREMENT 25

A. Experimental conditions.

Grid size (mm x mm)	50.0, 50.0
Step (mm)	5
Band	WCDMA 1900
Channel	Low
Signal	CDMA
Date of measurement	3/12/2012

B. HAC Measurement Results

Lower Band (Channel 9262):

Frequency (MHz): 1852.000000

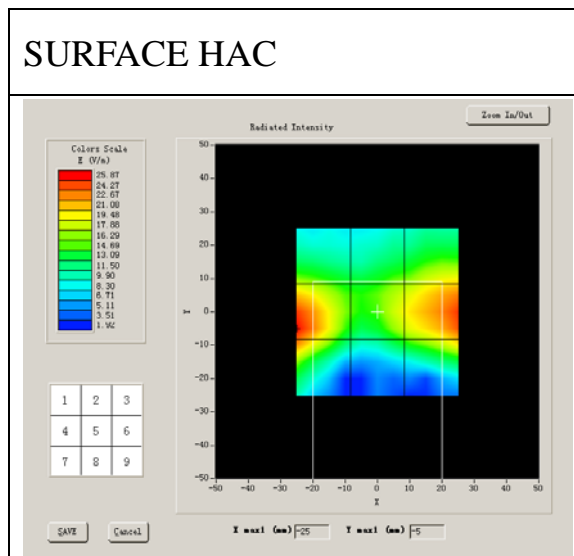

Probe Modulation Factor = 1.000000

Maximum value of total field = 24.76 V/m

Hearing Aid Near-Field Category: M4 (AWF 0 dB)

E in V/m

Grid 1: 16.15	Grid 2: 15.89	Grid 3: 19.38
Grid 4: 25.94	Grid 5: 19.51	Grid 6: 24.76
Grid 7: 24.32	Grid 8: 16.17	Grid 9: 21.75

MEASUREMENT 26

A. Experimental conditions.

Grid size (mm x mm)	50.0, 50.0
Step (mm)	5
Band	WCDMA 1900
Channel	Low
Signal	CDMA
Date of measurement	3/12/2012

B. HAC Measurement Results

Lower Band (Channel 9262):

Frequency (MHz): 1852.000000

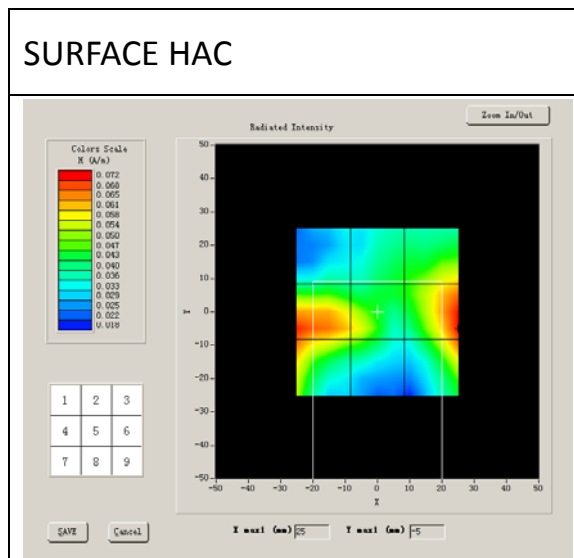

Probe Modulation Factor = 1.000000

Maximum value of total field = 0.07 A/m

Hearing Aid Near-Field Category: M4 (AWF 0 dB)

H in A/m

Grid 1: 0.04	Grid 2: 0.05	Grid 3: 0.06
Grid 4: 0.07	Grid 5: 0.06	Grid 6: 0.07
Grid 7: 0.07	Grid 8: 0.05	Grid 9: 0.07

MEASUREMENT 27

A. Experimental conditions.

Grid size (mm x mm)	50.0, 50.0
Step (mm)	5
Band	WCDMA 1900
Channel	Middle
Signal	CDMA
Date of measurement	3/12/2012

B. HAC Measurement Results

Middle Band (Channel 9400):

Frequency (MHz): 1880.000000

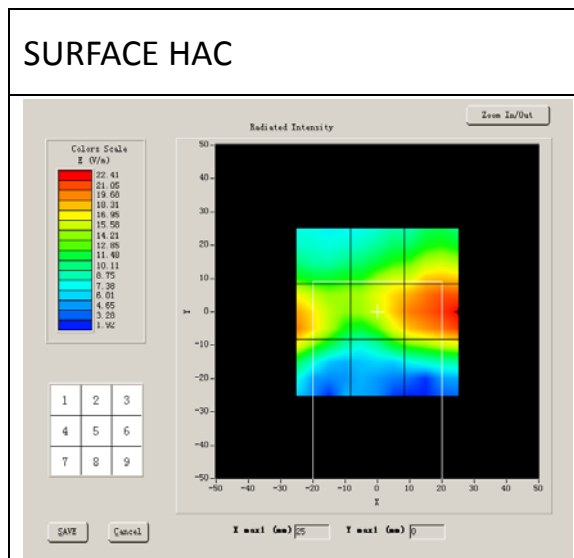

Probe Modulation Factor = 1.000000

Maximum value of total field = 19.90 V/m

Hearing Aid Near-Field Category: M4 (AWF 0 dB)

E in V/m

Grid 1: 12.81	Grid 2: 15.87	Grid 3: 18.44
Grid 4: 19.90	Grid 5: 19.58	Grid 6: 22.43
Grid 7: 18.49	Grid 8: 15.64	Grid 9: 18.68

MEASUREMENT 28

A. Experimental conditions.

Grid size (mm x mm)	50.0, 50.0
Step (mm)	5
Band	WCDMA 1900
Channel	Middle
Signal	CDMA
Date of measurement	3/12/2012

B. HAC Measurement Results

Middle Band (Channel 9400):

Frequency (MHz): 1880.000000

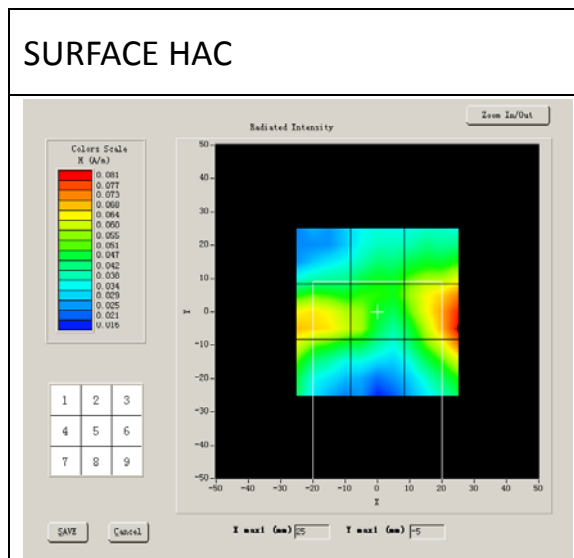

Probe Modulation Factor = 1.000000

Maximum value of total field = 0.07 A/m

Hearing Aid Near-Field Category: M4 (AWF 0 dB)

H in A/m

Grid 1: 0.04	Grid 2: 0.05	Grid 3: 0.06
Grid 4: 0.07	Grid 5: 0.06	Grid 6: 0.08
Grid 7: 0.06	Grid 8: 0.05	Grid 9: 0.08

Category	AWF (dB)	Limits for E-Field Emission (V/m)	Limits for H-Field Emission (A/m)
M1	0	199.5 - 354.8	0.6 - 1.07
	-5	149.6 - 266.1	0.45 - 0.8
M2	0	112.2 - 199.5	0.34 - 0.6
	-5	84.1 - 149.6	0.25 - 0.45
M3	0	63.1 - 112.2	0.19 - 0.34
	-5	47.3 - 84.1	0.15 - 0.25
M4	0	<63.1	<0.19
	-5	<47.3	<0.15

MEASUREMENT 29

A. Experimental conditions.

Grid size (mm x mm)	50.0, 50.0
Step (mm)	5
Band	WCDMA 1900
Channel	High
Signal	CDMA
Date of measurement	3/12/2012

B. HAC Measurement Results

Higher Band (Channel 9538):

Frequency (MHz): 1907.000000

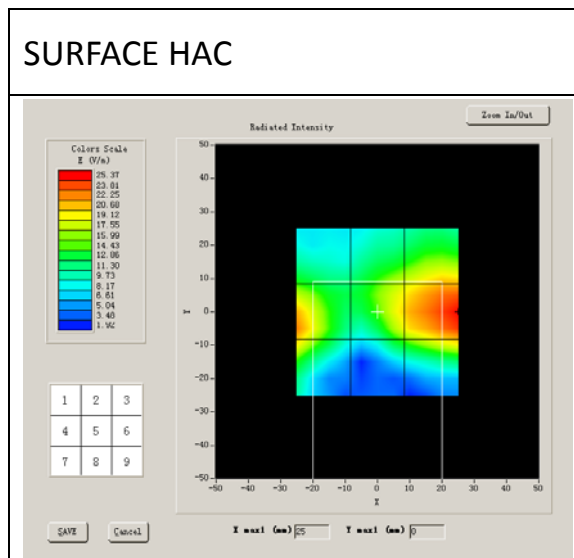

Probe Modulation Factor = 1.000000

Maximum value of total field = 22.51 V/m

Hearing Aid Near-Field Category: M4 (AWF 0 dB)

E in V/m

Grid 1: 13.41	Grid 2: 17.32	Grid 3: 20.06
Grid 4: 22.51	Grid 5: 20.60	Grid 6: 25.41
Grid 7: 20.96	Grid 8: 16.50	Grid 9: 21.45

MEASUREMENT 30

A. Experimental conditions.

Grid size (mm x mm)	50.0, 50.0
Step (mm)	5
Band	WCDMA 1900
Channel	High
Signal	CDMA
Date of measurement	3/12/2012

B. HAC Measurement Results

Higher Band (Channel 9538):

Frequency (MHz): 1907.000000

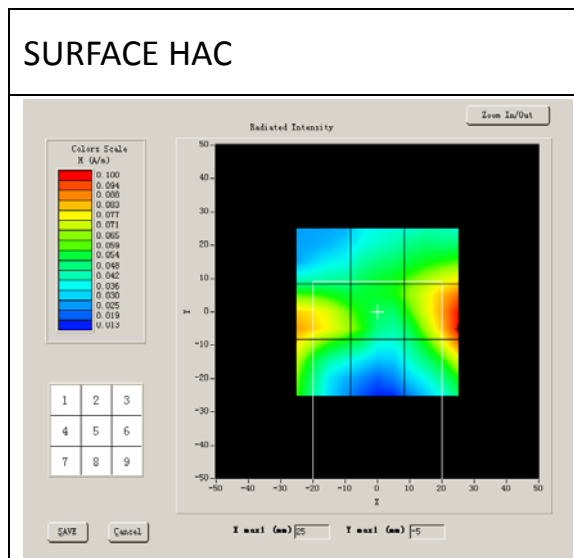

Probe Modulation Factor = 1.000000

Maximum value of total field = 0.09 A/m

Hearing Aid Near-Field Category: M4 (AWF 0 dB)

H in A/m

Grid 1: 0.05	Grid 2: 0.06	Grid 3: 0.08
Grid 4: 0.09	Grid 5: 0.06	Grid 6: 0.10
Grid 7: 0.08	Grid 8: 0.06	Grid 9: 0.09

Annex A Photographs of the EUT



System Performance Check (E-field)

Date of measurement: 3/12/2012

A. Experimental conditions.

Grid size (mm x mm)	50.0, 50.0
Step (mm)	5
Band	850 MHz
Channel	
Signal	CW

B. HAC Measurement Results

Frequency (MHz): 850.000000

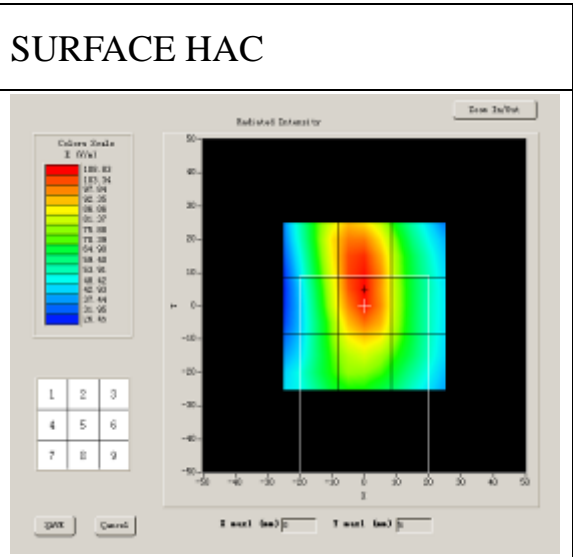

Device Reference Point: 0 , 0 , -7mm

Reference Value=193.184V/m; Power Drift:-1.4%

Probe Modulation Factor= 1.00

Maximum value of total field = 196.00 V/m;Location: 0, 7, 3 mm

E in V/m

Grid 1: 194.51	Grid 2: 198.12	Grid 3: 177.56
Grid 4: 192.69	Grid 5: 196.00	Grid 6: 178.98
Grid 7: 181.13	Grid 8: 194.18	Grid 9: 176.51

System Performance Check (H-field)

Date of measurement: 3/12/2012

A. Experimental conditions.

Grid size (mm x mm)	50.0, 50.0
Step (mm)	5
Band	850 MHz
Channel	
Signal	CW

B. HAC Measurement Results

Frequency (MHz): 850.000000

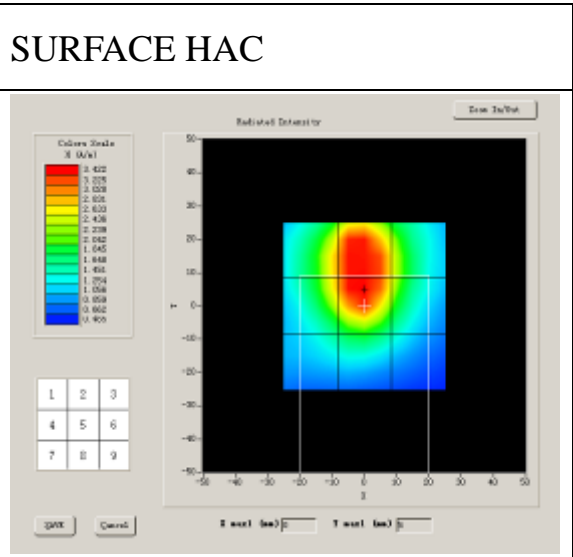

Device Reference Point: 0 , 0 , -7mm

Reference Value=0.412 A/m; Power Drift:-4.0%

Probe Modulation Factor= 1.00

Maximum value of total field = 0.429 A/m; Location: 0, 6, 3 mm

H in A/m

Grid 1: 0.302	Grid 2: 0.421	Grid 3: 0.336
Grid 4: 0.381	Grid 5: 0.429	Grid 6: 0.332
Grid 7: 0.370	Grid 8: 0.400	Grid 9: 0.239

System Performance Check (E-field)

Date of measurement: 3/12/2012

A. Experimental conditions.

Grid size (mm x mm)	50.0, 50.0
Step (mm)	5
Band	1900 MHz
Channel	
Signal	CW

B. HAC Measurement Results

Frequency (MHz): 1900.000000

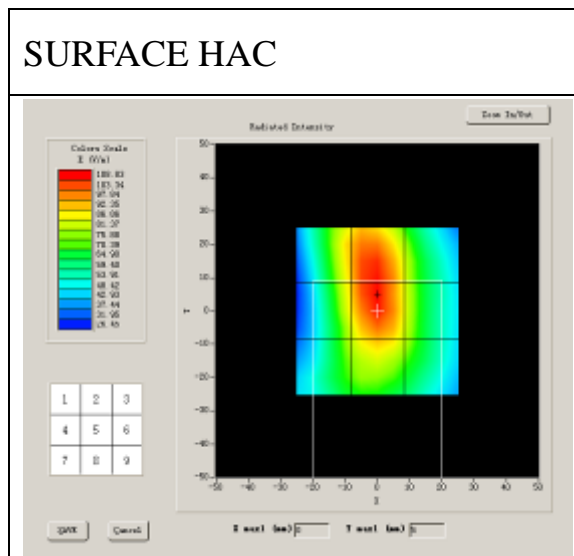

Maximum value of total field = 161.52V/m;

E in V/m

Grid 1: 145.51	Grid 2: 158.33	Grid 3: 136.11
Grid 4: 151.64	Grid 5: 161.52	Grid 6: 142.95
Grid 7: 141.52	Grid 8: 148.62	Grid 9: 126.77

System Performance Check (H-field)

Date of measurement: 3/12/2012

A. Experimental conditions.

Grid size (mm x mm)	50.0, 50.0
Step (mm)	5
Band	1900 MHz
Channel	
Signal	CW

B. HAC Measurement Results

Frequency (MHz): 1900.000000

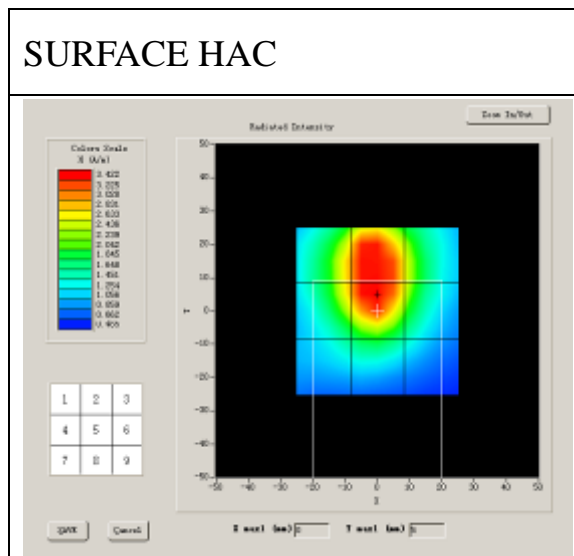

Probe Modulation Factor= 1.00

Maximum value of total field = 0.438 A/m;

H in A/m

Grid 1: 0.424	Grid 2: 0.434	Grid 3: 0.384
Grid 4: 0.437	Grid 5: 0.438	Grid 6: 0.415
Grid 7: 0.432	Grid 8: 0.415	Grid 9: 0.361