



# **FCC 47 CFR PART 15 SUBPART C**

## **TEST REPORT**

*For*

**Applicant :** verykool USA INC.

**Address :** 4350 Executive Dr. #100, San Diego, CA 92121

**Product Name :** GSM Mobile Phone

**Model Name :** S728

**Brand Name :** verykool

**FCC ID :** WA6S728

**Report No. :** DPH120608F04

**Date of Issue :** June. 28, 2012

**Issued by :** Super Test Service Technology Co., Ltd.

**Address :** Room 506, Hongyu Commercial Building, Gushu 2nd Road,  
Baoan District, Shenzhen, China

**Tel :** 0755-61196328

**Fax :** 0755-61196328

*The report consists 73 pages in total. It may be duplicated completely for legal use with the approval of the applicant. It should not be reproduced except in full, without the written approval of our laboratory. The client should not use it to claim product endorsement by STS. The test results in the report only apply to the tested sample. The test report shall be invalid without all the signatures of testing engineers, reviewer and approver.*

**TABLE OF CONTENTS**

**1. VERIFICATION OF CONFORMITY ..... 3**

**2. GENERAL INFORMATION ..... 4**

2.1 Product Information ..... 4

2.2 Objective ..... 5

2.3 Test Standards and Results ..... 5

**2.4 Environmental Conditions ..... 5**

**3. TEST FACILITY ..... 6**

3.1 Test Facility ..... 6

3.2 General Test Procedures ..... 6

3.3 FCC Part 15.205 Restricted Bands of Operations ..... 7

**4. TEST EQUIPMENT LIST ..... 8**

**5. 47 CFR Part 15 C 15.247 Requirements ..... 9**

5.1 6dB Bandwidth ..... 9

5.2 Peak Output Power ..... 15

5.3 Conducted Spurious Emission ..... 16

5.4 Band Edge ..... 26

5.5 Power Spectral Density (PSD) ..... 30

5.6 Conducted Emission ..... 35

5.7 Radiated Emission ..... 38

**APPENDIX 1 ..... 61**

**PHOTOGRAPHS OF TEST SETUP ..... 61**

**APPENDIX 2 ..... 64**

**PHOTOGRAPHS OF EUT ..... 64**

Revision History		
Issue	Date	Reason for Revision
1.0	June 28, 2012	First edition

## 1. VERIFICATION OF CONFORMITY

<b>Equipment Under Test:</b>	GSM Mobile Phone
<b>Brand Name:</b>	verykool
<b>Model Number:</b>	S728
<b>Series Model Name:</b>	N/A
<b>Difference description:</b>	N/A
<b>FCC ID:</b>	WA6S728
<b>Applicant:</b>	verykool USA INC. 4350 Executive Dr. #100, San Diego, CA 92121
<b>Manufacturer:</b>	Shenzhen Ginwave Technologies Ltd. 4/F, R2-A, High-Tech Industrial Park, Shenzhen 518057, China
<b>Technical Standards:</b>	47 CFR Part 15 Subpart C
<b>File Number:</b>	DPH120608F04
<b>Date of test:</b>	June 11 ~ June 28, 2012
<b>Deviation:</b>	None
<b>Condition of Test Sample:</b>	Normal
<b>Test Result:</b>	PASS

The above equipment was tested by STS. For compliance with the requirements set forth in FCC rules and the Technical Standards mentioned above. This said equipment in the configuration described in this report shows the maximum emission levels emanating from equipment and the level of the immunity endurance of the equipment are within the compliance requirements.

The test results of this report relate only to the tested sample identified in this report.

Tested by (+ signature):

*Rex Luo*

Rex Luo

Test Engineer

Approved by (+ signature):

*Joe Jia*

Joe Jia

Manager

## 2. GENERAL INFORMATION

### 2.1 Product Information

Description:	GSM Mobile Phone
Brand Name:	verykool
Model Name:	S728
Frequency Range:	IEEE 802.11b/g mode: 2412MHz- 2462MHz IEEE 802.11n Standard-40 MHz Channel mode: 2422MHz- 2452MHz
Test Frequency:	IEEE 802.11b/g mode: 2412MHz, 2437MHz, 2462MHz IEEE 802.11n Standard-40 MHz Channel mode: 2422MHz, 2437MHz, 2452MHz
Number of Channels:	IEEE 802.11b/g mode: 11 Channels IEEE 802.11n Standard-40 MHz Channel mode: 7 Channels
Modulation Technique:	IEEE 802.11b mode: DSSS (1, 2, 5.5 and 11 Mbps) IEEE 802.11g mode: OFDM (6, 9, 12, 18, 24, 36, 48 and 54 Mbps) IEEE 802.11n Standard-40 MHz Channel mode: OFDM (13.5, 27, 40.5, 54, 81, 108, 121.5, 135Mbps)
Power Supply:	DC 5V by AC/DC adapter 100~240V 50/60Hz DC 3.7V by Lithium-ion Battery
Temperature Range:	-20°C ~ +50°C

**NOTE:**

1. For more detailed features description about the EUT, please refer to User's Manual.

## 2.2 Objective

The objective of the report is to perform tests according to 47 CFR Part 15 Subpart C for the EUT FCC ID Certification:

No.	Identity	Document Title
1	47 CFR Part 15(10-1-09 Edition)	Radio Frequency Devices

## 2.3 Test Standards and Results

Test items and the results are as bellow:

No.	Section	Description	Result	Date of Test
1	15.247(a)(2)	6dB Bandwidth	PASS	2012-06-21
2	15.247(b)(3)	Peak Output Power	PASS	2012-06-21
3	15.247(d)	conducted spurious emission	PASS	2012-06-21
4	15.247(d)	Band Edge	PASS	2012-06-28
5	15.247(e)	Power Spectral Density	PASS	2012-06-28
6	15.207	Conducted Emission	PASS	2012-06-13
7	15.247(d) 15.205 15.209	Radiated Emission	PASS	2012-06-13

Note: 1. The test result judgment is decided by the limit of measurement standard  
2. The information of measurement uncertainty is available upon the customer's request.

## 2.4 Environmental Conditions

During the measurement the environmental conditions were within the listed ranges:

- Temperature: 15-35°C
- Humidity: 30-60 %
- Atmospheric pressure: 86-106 kPa

### 3. TEST FACILITY

#### 3.1 Test Facility

Test Site:	Most Technology Service Co., Ltd.
Location:	No.5, Nangshan 2nd Rd., North Hi-Tech Industrial park, Nanshan, Shenzhen, Guangdong, China
Description:	There is one 3m semi-anechoic an area test sites and two line conducted labs for final test. The Open Area Test Sites and the Line Conducted labs are constructed and calibrated to meet the FCC requirements in documents ANSI C63.4 and CISPR 16 requirements. The FCC Registration Number is <b>490827</b> .
Site Filing:	The site description is on file with the Federal Communications Commission, 7435 Oakland Mills Road, Columbia, MD 21046.
Instrument Tolerance:	All measuring equipment is in accord with ANSI C63.4 and CISPR 16 requirements that meet industry regulatory agency and accreditation agency requirement.
Ground Plane:	Two conductive reference ground planes were used during the Line Conducted Emission, one in vertical and the other in horizontal. The dimensions of these ground planes are as below. The vertical ground plane was placed distancing 40 cm to the rear of the wooden test table on where the EUT and the support equipment were placed during test. The horizontal ground plane projected 50 cm beyond the footprint of the EUT system and distanced 80 cm to the wooden test table. For Radiated Emission Test, one horizontal conductive ground plane extended at least 1m beyond the periphery of the EUT and the largest measuring antenna, and covered the entire area between the EUT and the antenna. It has no holes or gaps having longitudinal dimensions larger than one-tenth of a wavelength at the highest frequency of measurement up to 1GHz.

#### 3.2 General Test Procedures

##### Conducted Emissions

The EUT is placed on the turntable, which is 0.8 m above ground plane. According to the requirements in Section 13.1.4.1 of ANSI C63.4:2009, Conducted emissions from the EUT measured in the frequency range between 0.15 MHz and 30MHz using CISPR Quasi-peak and average detector modes.

Radiated Emissions

The EUT is placed on a turn table, which is 0.8 m above ground plane. The turntable shall rotate 360 degrees to determine the position of maximum emission level. EUT is set 3m away from the receiving antenna, which varied from 1m to 4m to find out the highest emission. And also, each emission was to be maximized by changing the polarization of receiving antenna both horizontal and vertical. In order to find out the maximum emissions, exploratory radiated emission measurements were made according to the requirements in Section 13.1.4.1 of ANSI C63.4:2009.

**3.3 FCC Part 15.205 Restricted Bands of Operations**

(a) Except as shown in paragraph (d) of this section, only spurious emissions are permitted in any of the frequency bands listed below:

MHz	MHz	MHz	GHz
0.090 0.110	16.42 - 16.423	399.9 - 410	4.5 - 5.15
<sup>1</sup> 0.495 0.505	16.69475 - 16.69525	608 - 614	5.35 - 5.46
2.1735 2.1905	16.80425 - 16.80475	960 - 1240	7.25 - 7.75
4.125 - 4.128	25.5 - 25.67	1300 - 1427	8.025 - 8.5
4.17725 - 4.17775	37.5 - 38.25	1435 - 1626.5	9.0 - 9.2
4.20725 - 4.20775	73 - 74.6	1645.5 - 1646.5	9.3 - 9.5
6.215 - 6.218	74.8 - 75.2	1660 - 1710	10.6 - 12.7
6.26775 - 6.26825	108 - 121.94	1718.8 - 1722.2	13.25 - 13.4
6.31175 - 6.31225	123 - 138	2200 - 2300	14.47 - 14.5
8.291 - 8.294	149.9 - 150.05	2310 - 2390	15.35 - 16.2
8.362 8.366	156.52475 - 156.52525	2483.5 - 2500	17.7 - 21.4
8.37625 - 8.38675	156.7 - 156.9	2655 - 2900	22.01 - 23.12
8.41425 - 8.41475	162.0125 - 167.17	3260 - 3267	23.6 - 24.0
12.29 - 12.293	167.72 - 173.2	3332 - 3339	31.2 - 31.8
12.51975 - 12.52025	240 - 285	3345.8 - 3358	36.43 - 36.5
12.57675 - 12.57725	322 - 335.4	3600 - 4400	( <sup>2</sup> )
13.36 13.41			

<sup>1</sup> Until February 1, 1999, this restricted band shall be 0.490-0.510 MHz.

<sup>2</sup> Above 38.6

(b) Except as provided in paragraphs (d) and (e), the field strength of emissions appearing within these frequency bands shall not exceed the limits shown in Section 15.209. At frequencies equal to or less than 1000 MHz, compliance with the limits in Section 15.209 shall be demonstrated using measurement instrumentation employing a CISPR quasipeak detector. Above 1000 MHz, compliance with the emission limits in Section 15.209 shall be demonstrated based on the average value of the measured emissions. The provisions in Section 15.35 apply to these measurements.

#### 4. TEST EQUIPMENT LIST

**Instrumentation:** The following list contains equipment used at MOST for testing. The equipment conforms to the CISPR 16-1/ANSI C63.2 Specifications for Electromagnetic Interference and Field Strength Instrumentation from 10 kHz to 1.0 GHz or above.

No.	Equipment	Manufacturer	Model No.	S/N	Calibration due date
1	Test Receiver	Rohde & Schwarz	ESCI	100492	2013/4/21
2	L.I.S.N.	Rohde & Schwarz	ENV216	100093	2013/4/21
3	Coaxial Switch	Anritsu Corp	MP59B	6200283933	2013/3/14
4	Terminator	Hubersuhner	50Ω	No.1	2013/3/14
5	RF Cable	SchwarzBeck	N/A	No.1	N/A
6	Test Receiver	Rohde & Schwarz	ESPI	101202	2013/4/21
7	Test Antenna – Horn	Schwarzbeck	BBHA 9120C	--	2013/3/14
8	Test Antenna – Bi-Log	Schwarzbeck	VULB 9163	--	2013/3/14
9	Power Splitter	Weinschel	1506A	NW521	N/A
10	Spectrum Analyzer	Agilent	4408B	MY41440460	2013/4/21
11	Cable	Resenberger	N/A	NO.1	N/A
12	Cable	SchwarzBeck	N/A	NO.2	N/A
13	Cable	SchwarzBeck	N/A	NO.3	N/A
14	Signal Generator	IFR	2032	203002/100	2013/5/21
15	EPM Series Power Meter	Agilent	E4418B	GB43318063	2013/5/21
16	Universal Radio Communication Tester	ROHDE&SCHWARZ	CMU200	0304789	2013/4/21
17	Telecommunication Antenna	European Antennas	PSA 75301R/170	0304213	2012/03/14
18	DC Power Supply	Good Will	GPS-3030DD	EF920938	2013/4/21
19	Full-Anechoic Chamber	Albatross	9m*6m*6m	(n.a.)	2013/4/15

**NOTE:** Equipments listed above have been calibrated and are in the period of validation.



## 5. 47 CFR Part 15 C 15.247 Requirements

### 5.1 6dB Bandwidth

#### 5.1.1 Definition

Systems using digital modulation techniques may operate in the 902–928 MHz, 2400–2483.5 MHz, and 5725–5850 MHz bands. The minimum 6 dB bandwidth shall be at least 500 kHz.

#### 5.1.2 Test Description

The EUT is powered by the Battery, is coupled to the Spectrum Analyzer (SA) through the Attenuator/DC Block. The path loss as the factor is calibrated to correct the reading. During the measurement, the EUT is activated and is set to operate at maximum power. The RF load attached to the EUT antenna terminal is 50Ohm.

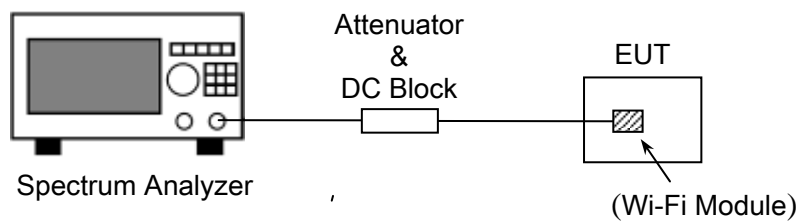

Figure 1: RF Test Setup

#### 5.1.3 Test Result

The lowest, middle and highest channels are selected to perform testing to record the 6 dB bandwidth of the Module.

802.11b Test Mode

Channel	Frequency (MHz)	6 dB Bandwidth (MHz)	Limits (kHz)	Result
1	2412	9.45	≥500	PASS
6	2437	9.62	≥500	PASS
11	2462	9.92	≥500	PASS

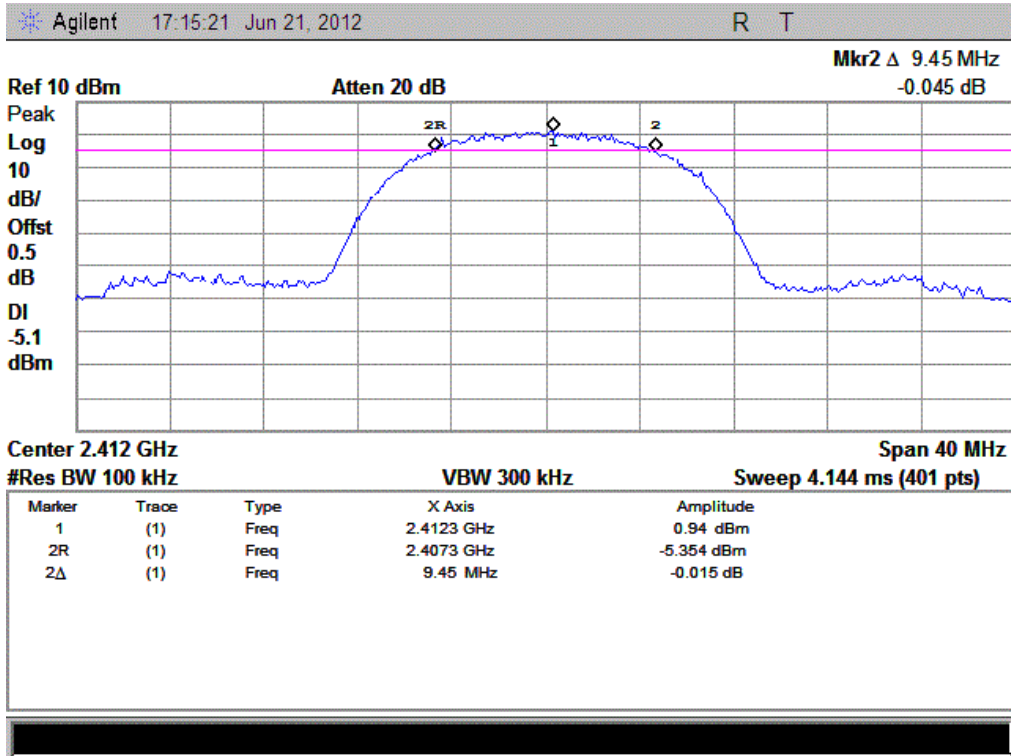

(CH Low)

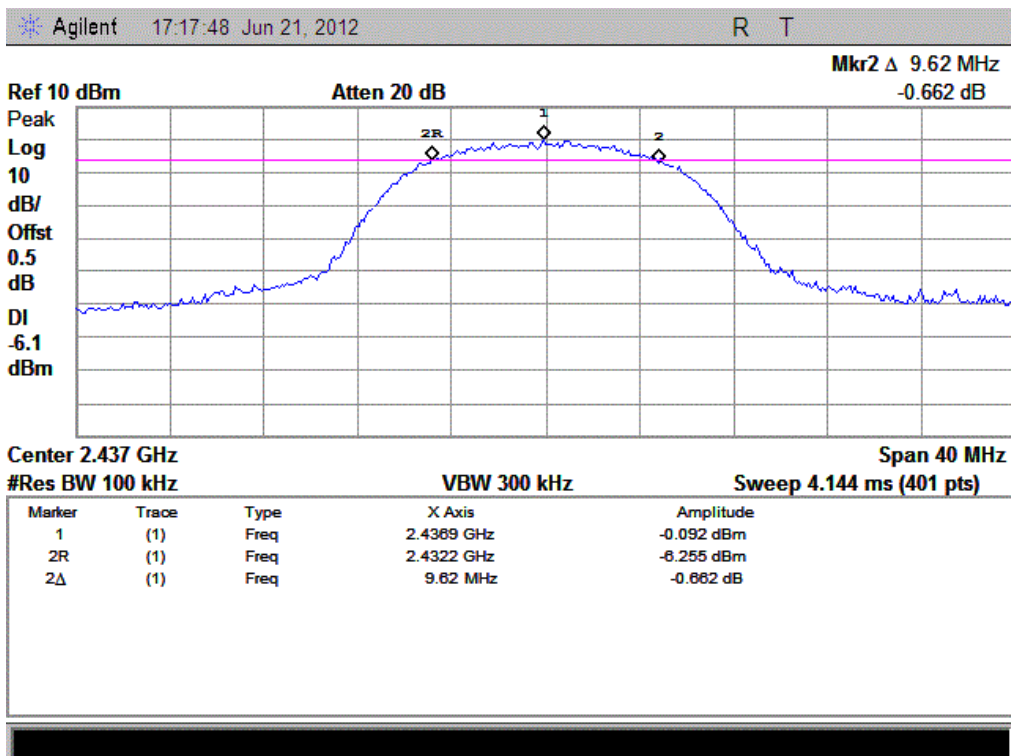

(CH Mid)

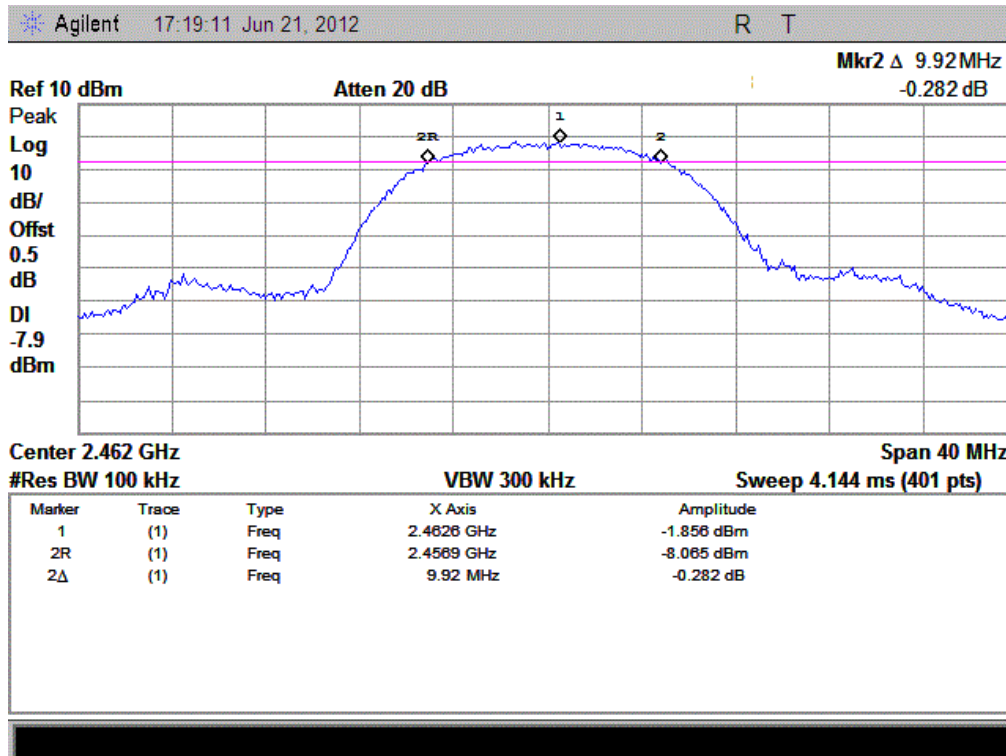

(CH High)

802.11g Test Mode

Channel	Frequency (MHz)	6 dB Bandwidth (MHz)	Limits (kHz)	Result
1	2412	16.65	≥500	PASS
6	2437	16.76	≥500	PASS
11	2462	16.75	≥500	PASS

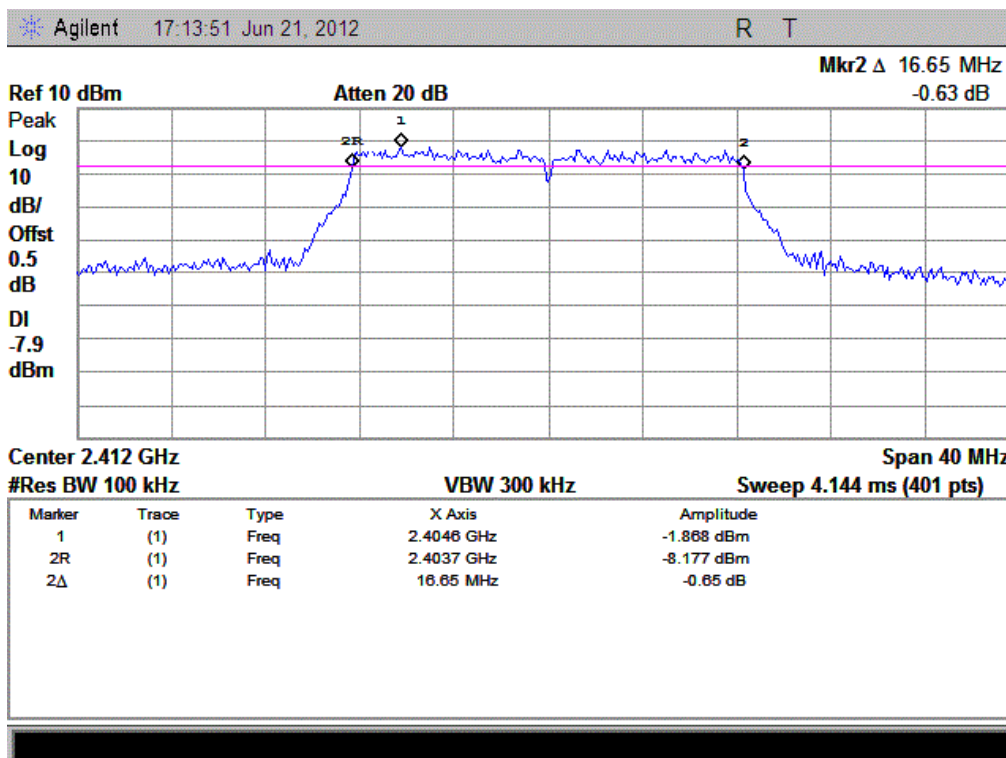

(CH Low)

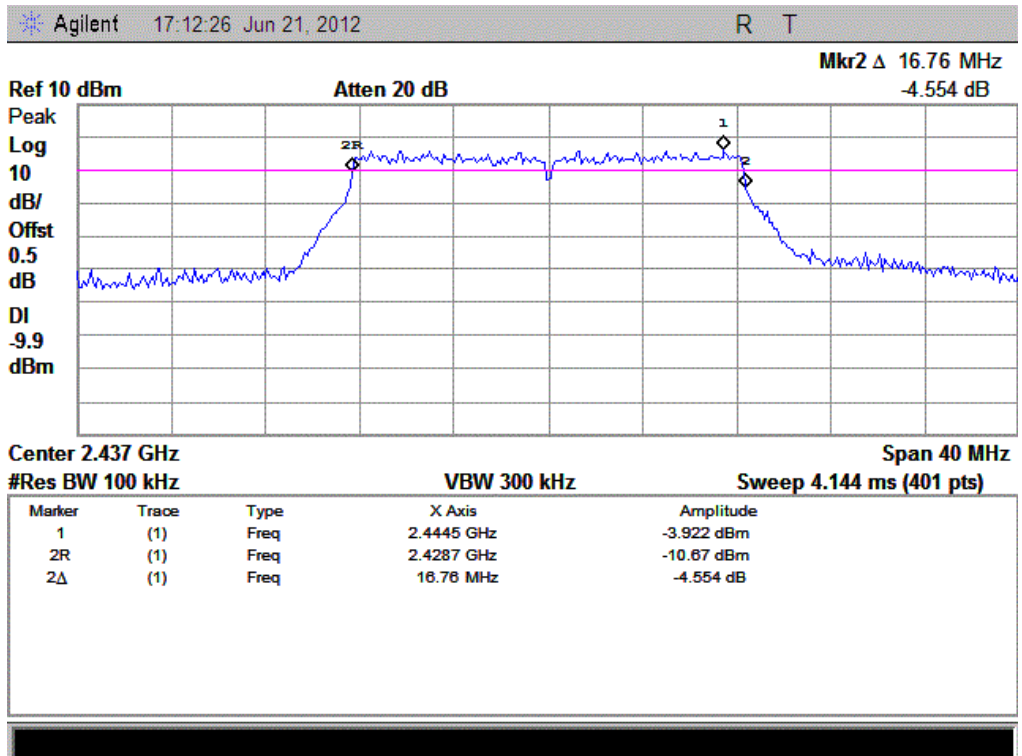

(CH Mid)

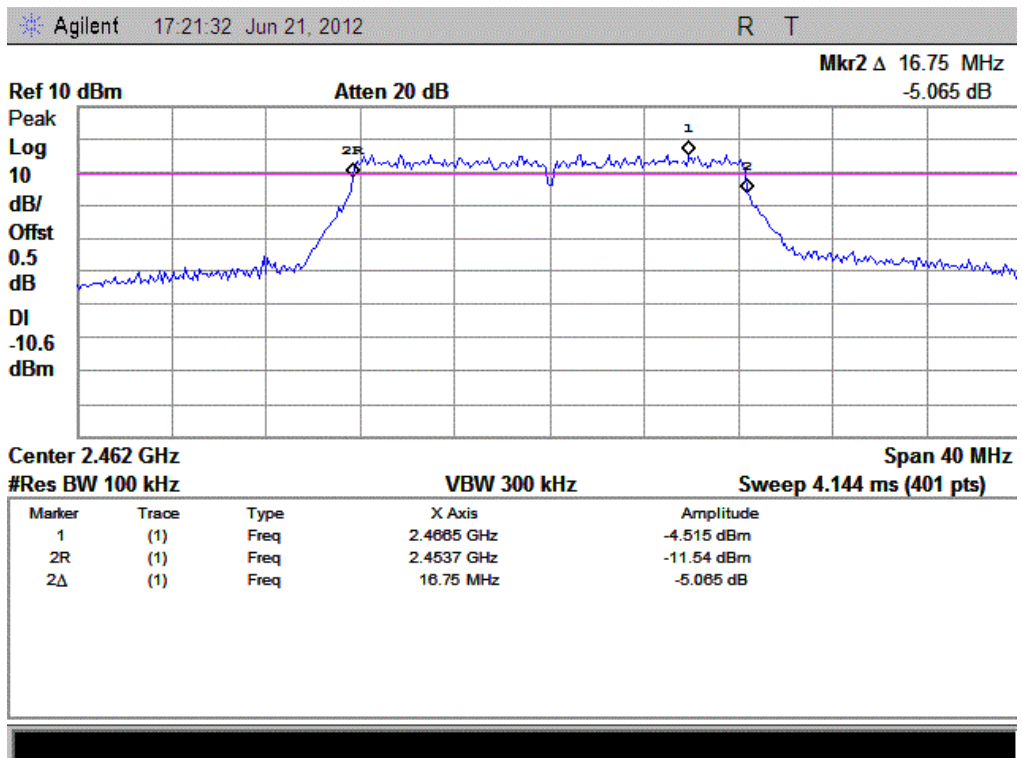

(CH High)

802.11n-40MHz Test Mode

Channel	Frequency (MHz)	6 dB Bandwidth (MHz)	Limits (kHz)	Result
3	2422	36.78	≥500	PASS
6	2437	36.86	≥500	PASS
9	2452	36.43	≥500	PASS

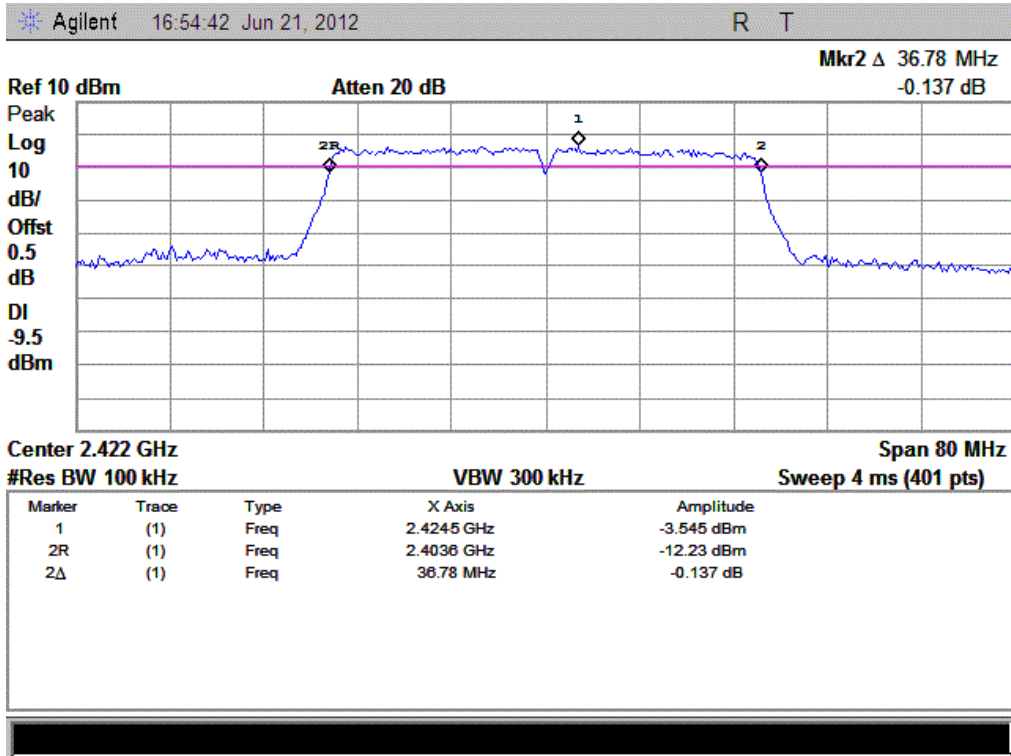

(CH Low)

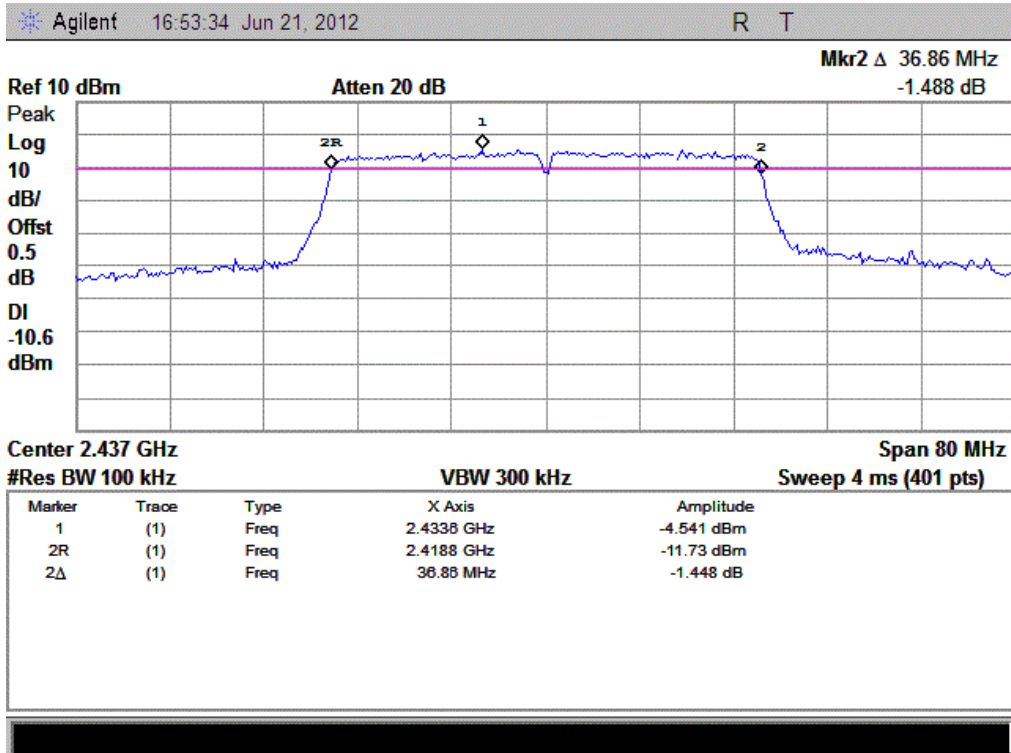

(CH Mid)

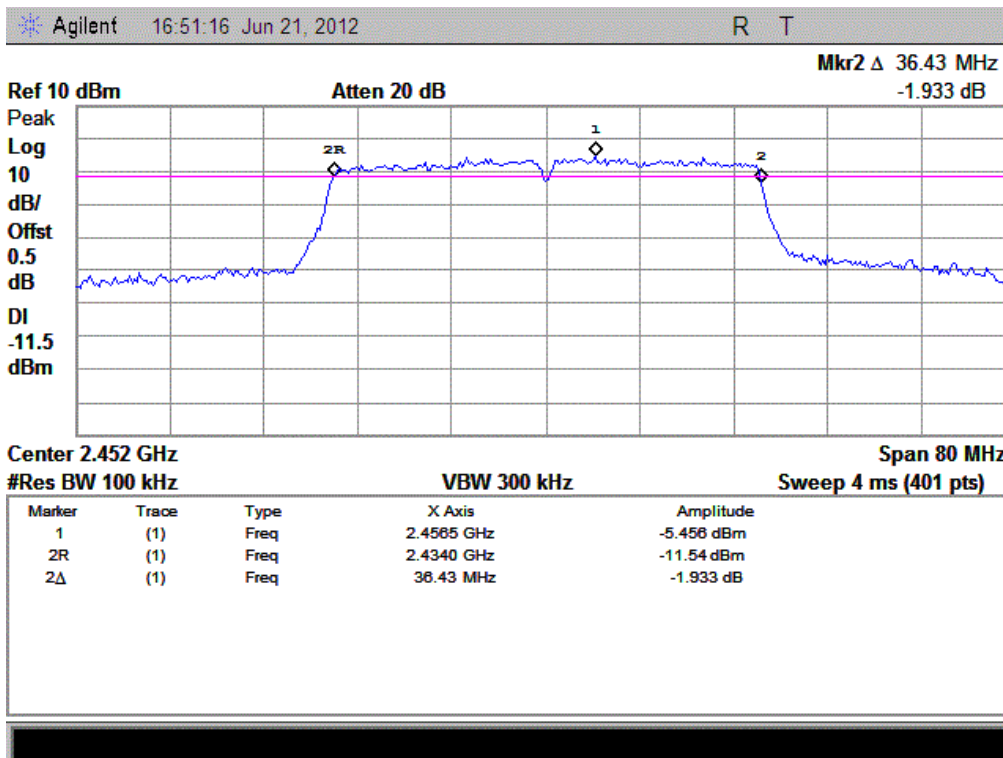

(CH High)

## 5.2 Peak Output Power

### 5.2.1 Definition

For systems using digital modulation in the 902–928 MHz, 2400–2483.5 MHz, and 5725–5850 MHz bands: 1 Watt. As an alternative to a peak power measurement, compliance with the one Watt limit can be based on a measurement of the maximum conducted output power.

### 5.2.2 Test Description



The EUT which is powered by Battery, is coupled to the Power Meter; the RF load attached to the EUT antenna terminal is 50Ohm; the path loss as the factor is calibrated to correct the reading.

### 5.2.3 Test Result

The lowest, middle and highest channels are selected to perform testing to verify the conducted RF output peak power of the Module.

#### 802.11b Test Mode

Channel	Frequency (MHz)	Rate (Mbps)	Measured Output Peak Power		Limit		Verdict
			dBm	W	dBm	W	
1	2412	1Mbps	16.67	0.046	30	1	PASS
		11Mbps	16.32	0.043			PASS
6	2437	1Mbps	16.42	0.044			PASS
		11Mbps	15.85	0.038			PASS
11	2462	1Mbps	17.06	0.051			PASS
		11Mbps	16.17	0.041			PASS

#### 802.11g Test Mode

Channel	Frequency (MHz)	Rate (Mbps)	Measured Output Peak Power		Limit		Verdict
			dBm	W	dBm	W	
1	2412	6Mbps	14.25	0.027	30	1	PASS
		54Mbps	13.72	0.024			PASS
6	2437	6Mbps	14.74	0.030			PASS
		54Mbps	14.03	0.025			PASS
11	2462	6Mbps	14.66	0.029			PASS
		54Mbps	14.22	0.026			PASS

#### 802.11n Test Mode (Standard-40 MHz Channel mode)

Channel	Frequency (MHz)	Rate (Mbps)	Measured Output Peak Power		Limit		Verdict
			dBm	W	dBm	W	
3	2422	13.5Mbps	14.15	0.026	30	1	PASS
		135Mbps	13.17	0.021			PASS
6	2437	13.5Mbps	15.04	0.032			PASS
		135Mbps	13.75	0.024			PASS
9	2452	13.5Mbps	14.43	0.028			PASS
		135Mbps	13.41	0.022			PASS

### 5.3 Conducted Spurious Emission

#### 5.3.1 Definition

In any 100 kHz bandwidth outside the frequency band in which the spread spectrum or digitally modulated intentional radiator is operating, the radio frequency power that is produced by the intentional radiator shall be at least 20 dB below that in the 100 kHz bandwidth within the band that contains the highest level of the desired power, based on either an RF conducted or a radiated measurement, provided the transmitter demonstrates compliance with the peak conducted power limits.

#### 5.3.2 Test Description

See section 5.1.2 of this report.

#### 5.3.3 Test Result

The measurement frequency range is from 30MHz to the 10th harmonic of the fundamental frequency. The lowest, middle and highest channels are tested to verify the spurious emissions.

#### 802.11b Test Mode

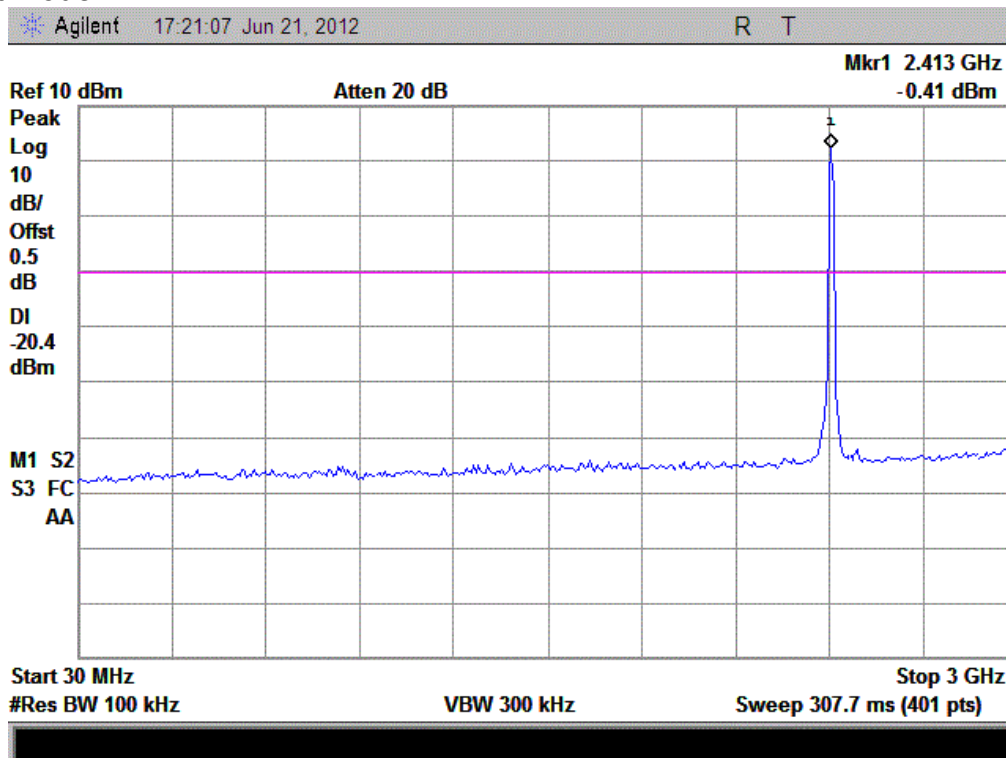



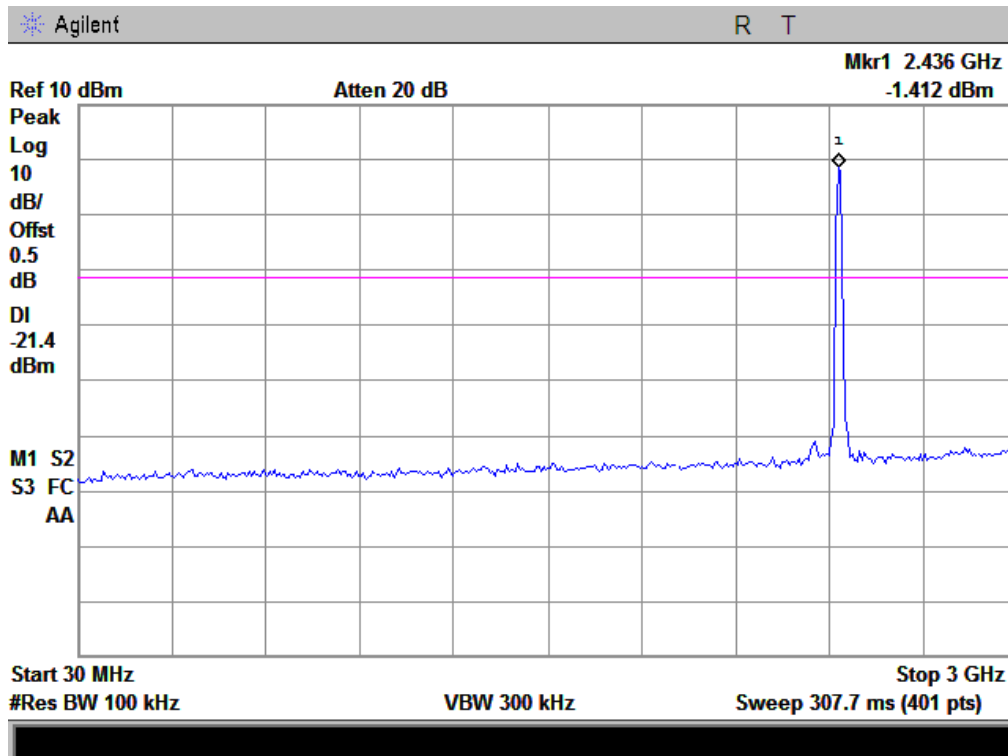
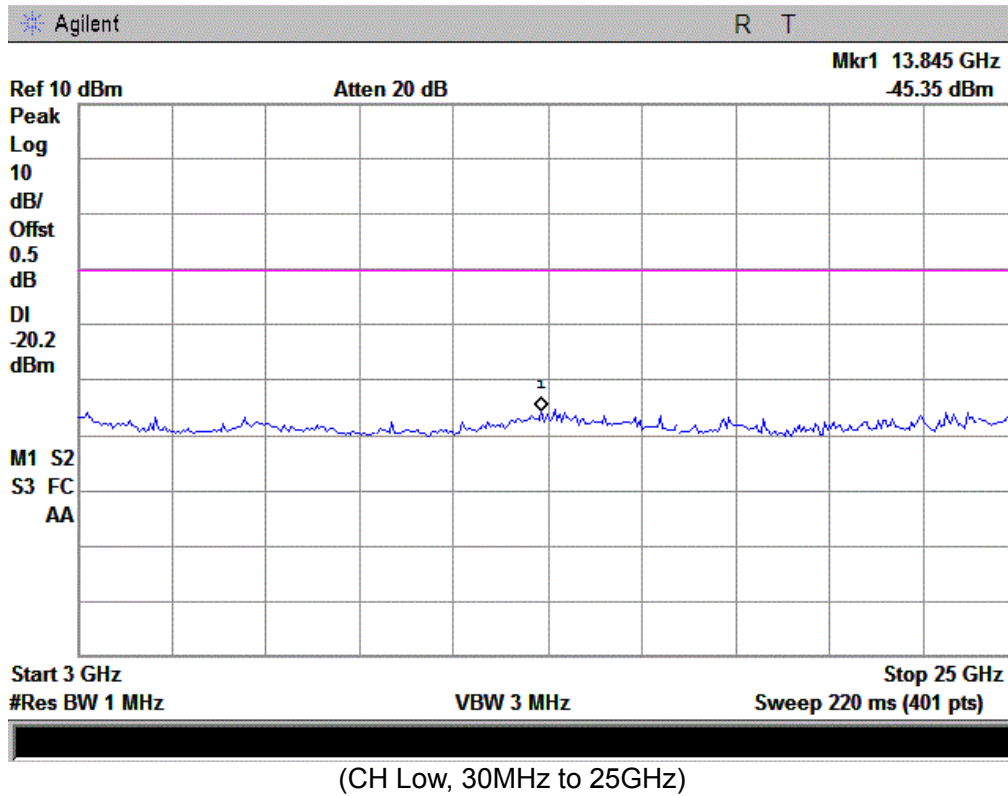

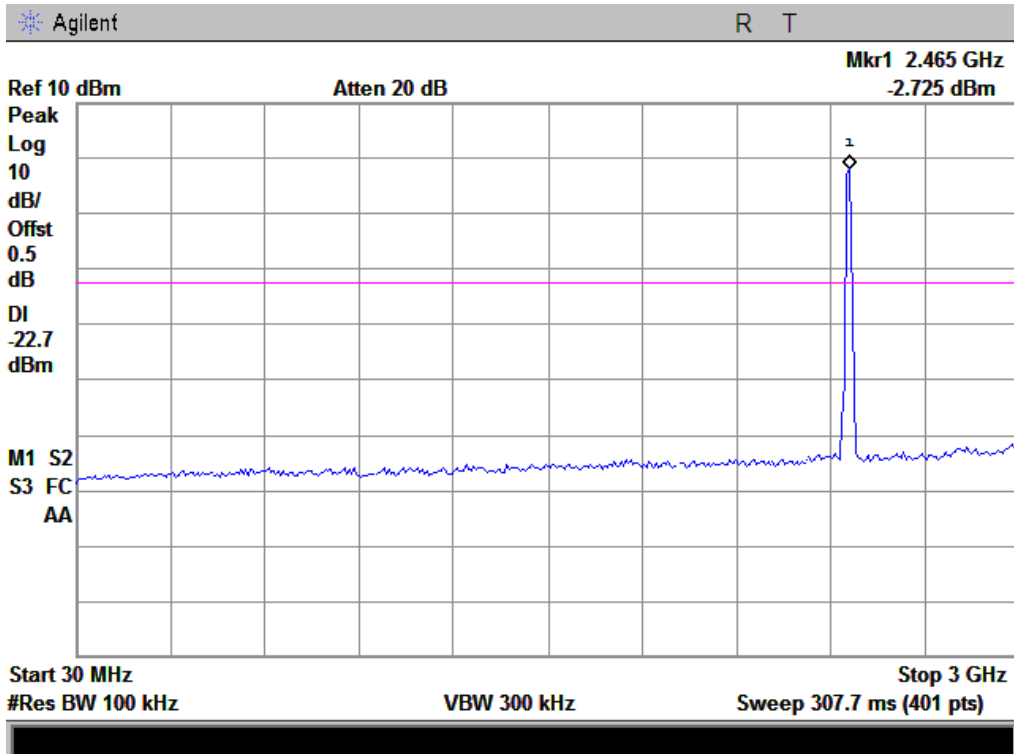
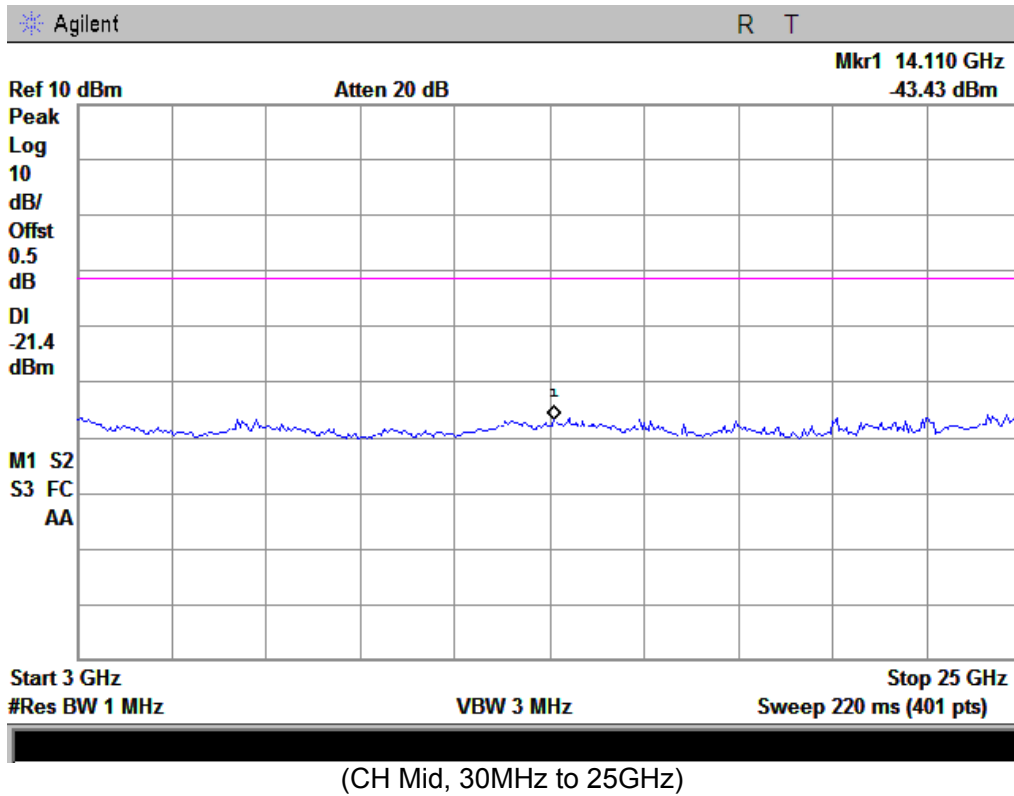

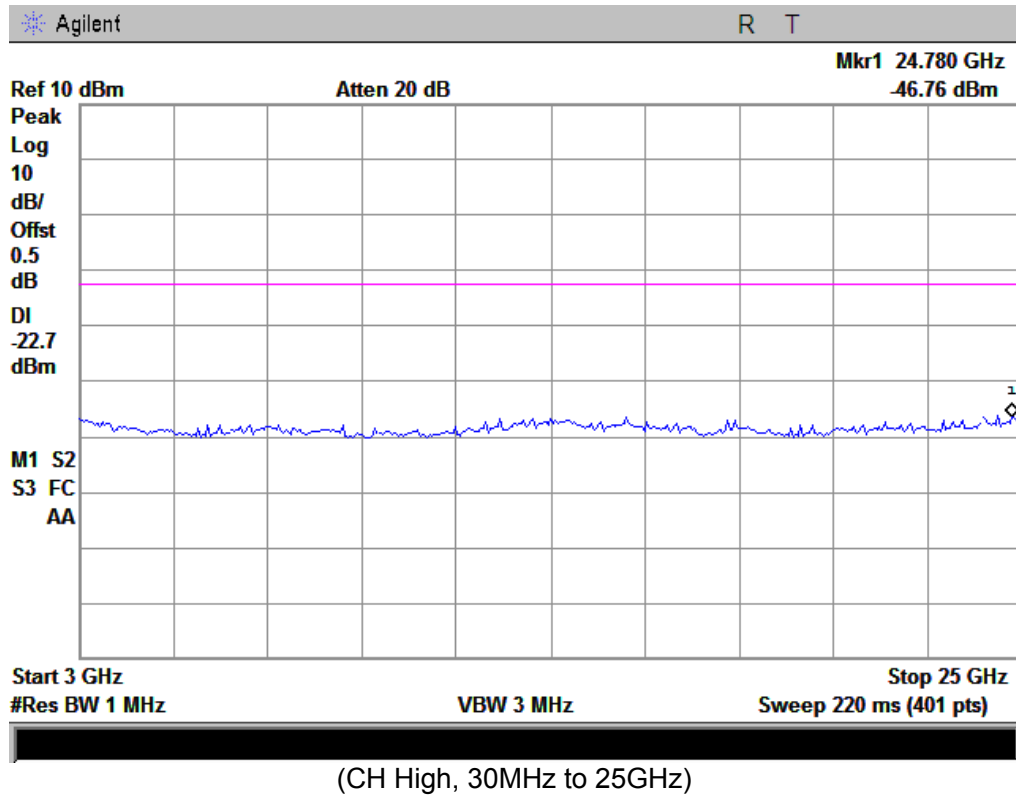

**Note:** The power of the Module transmitting frequency should be ignored.

### 802.11g Test Mode

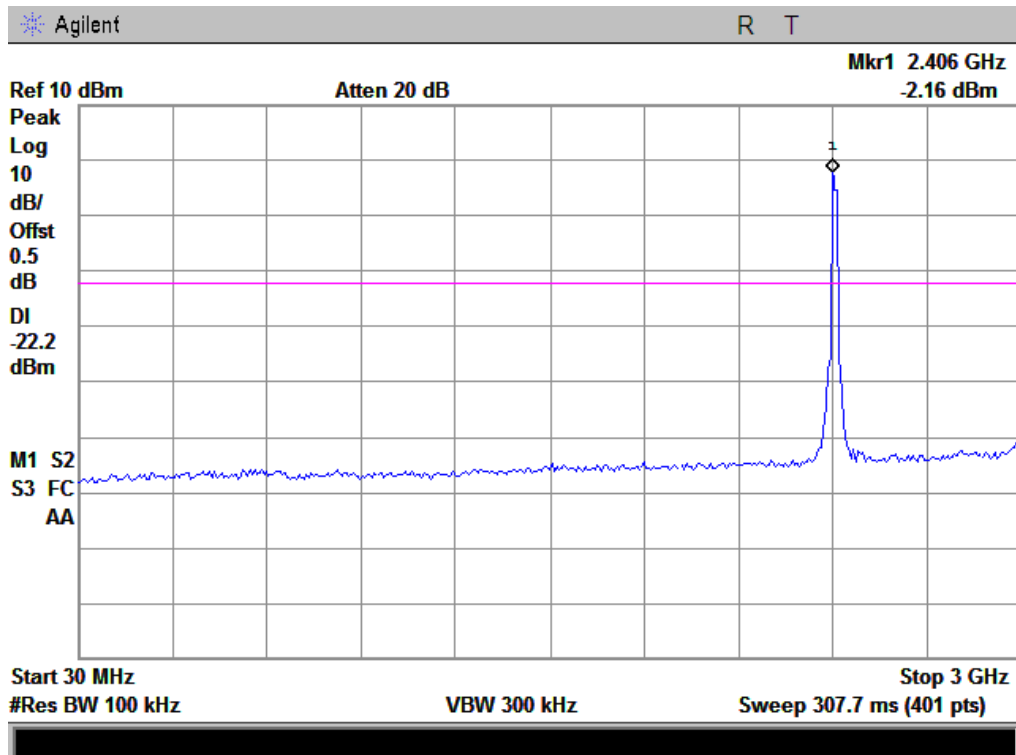

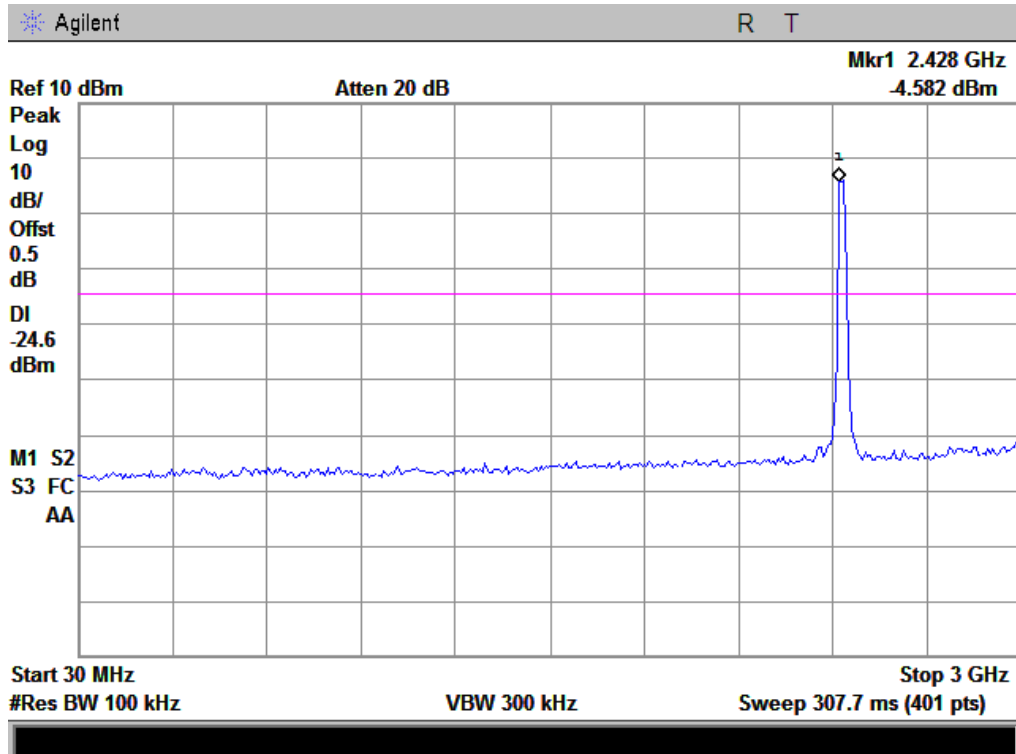
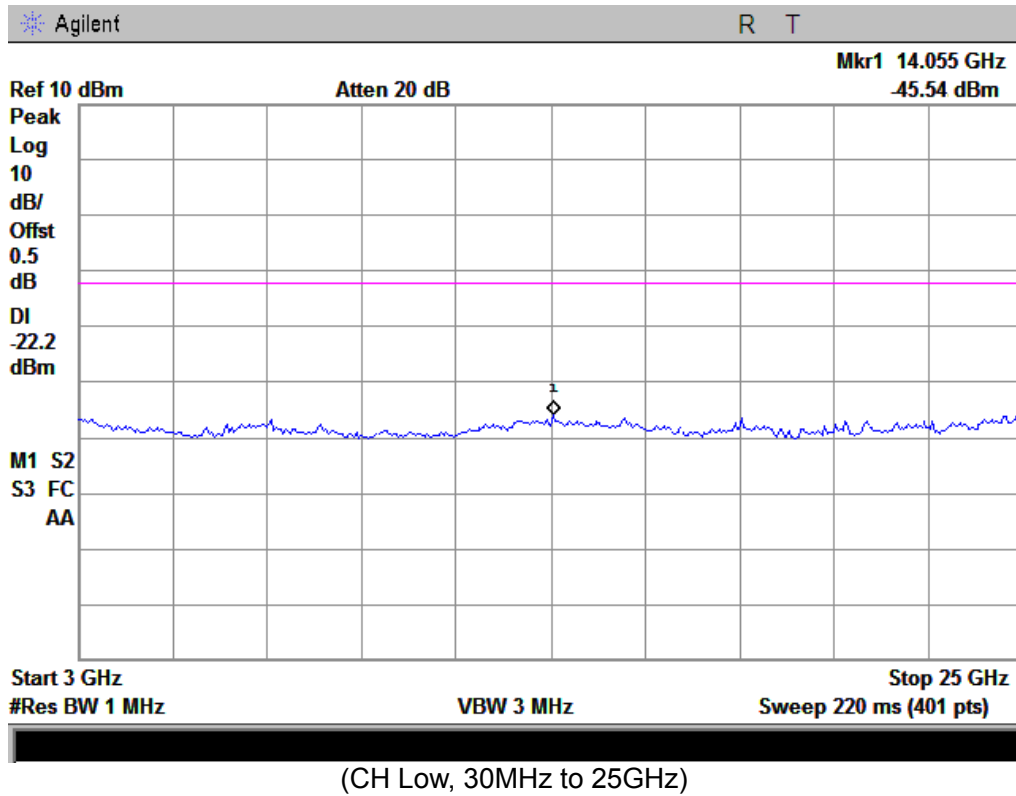

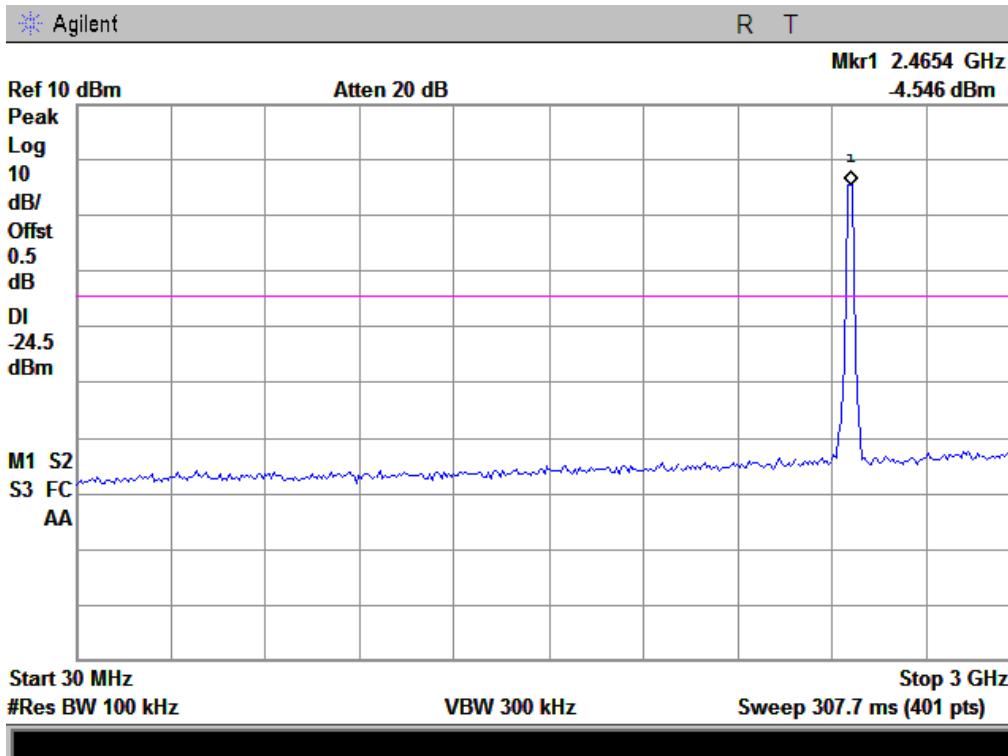
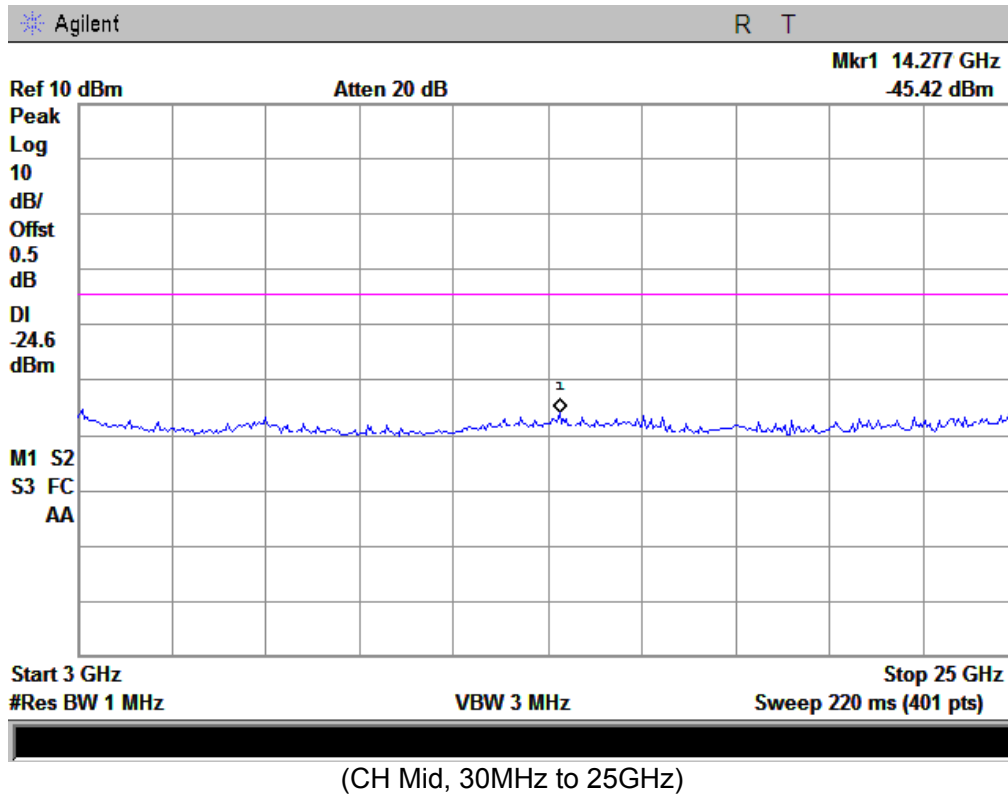

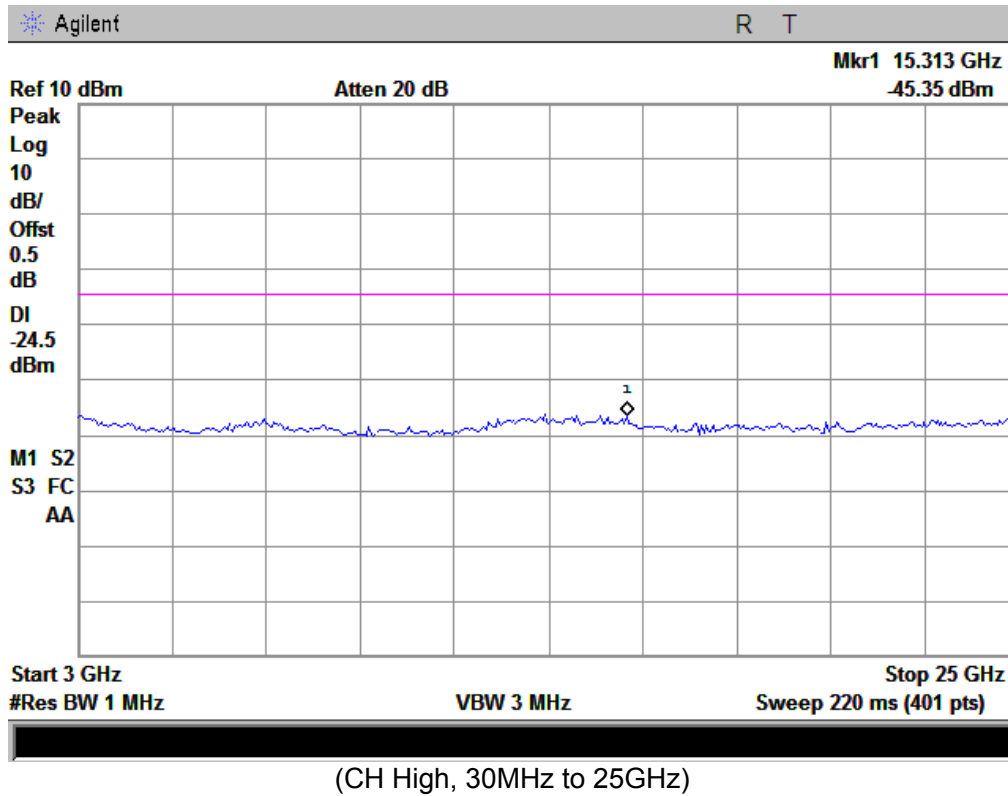

**Note:** The power of the Module transmitting frequency should be ignored.

### 802.11n-40MHz Test Mode

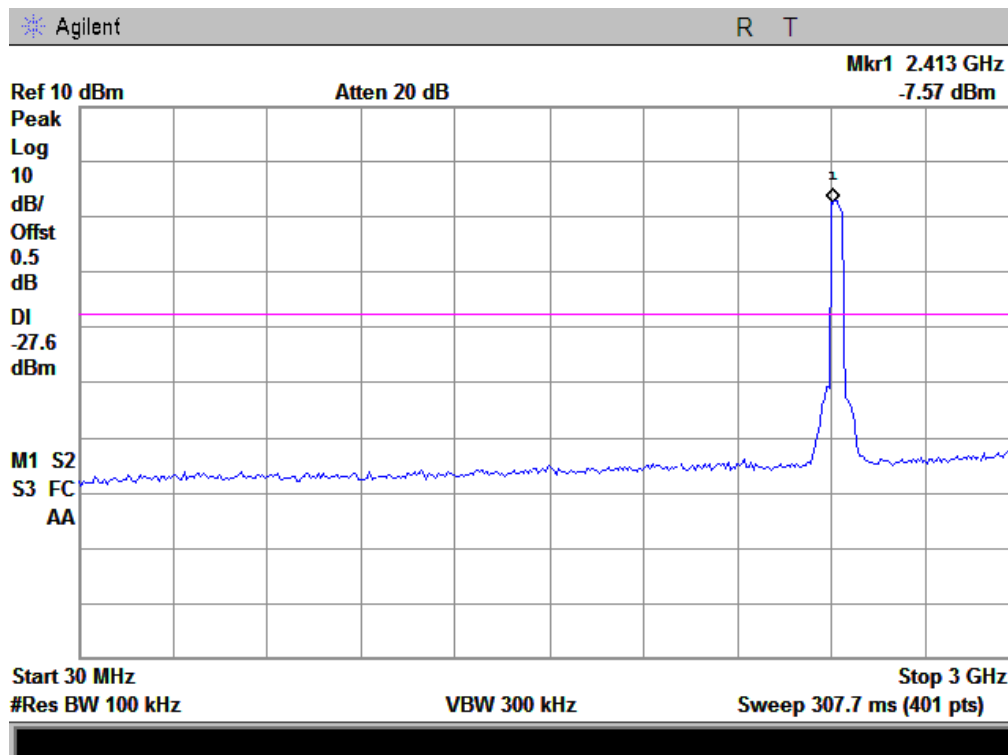

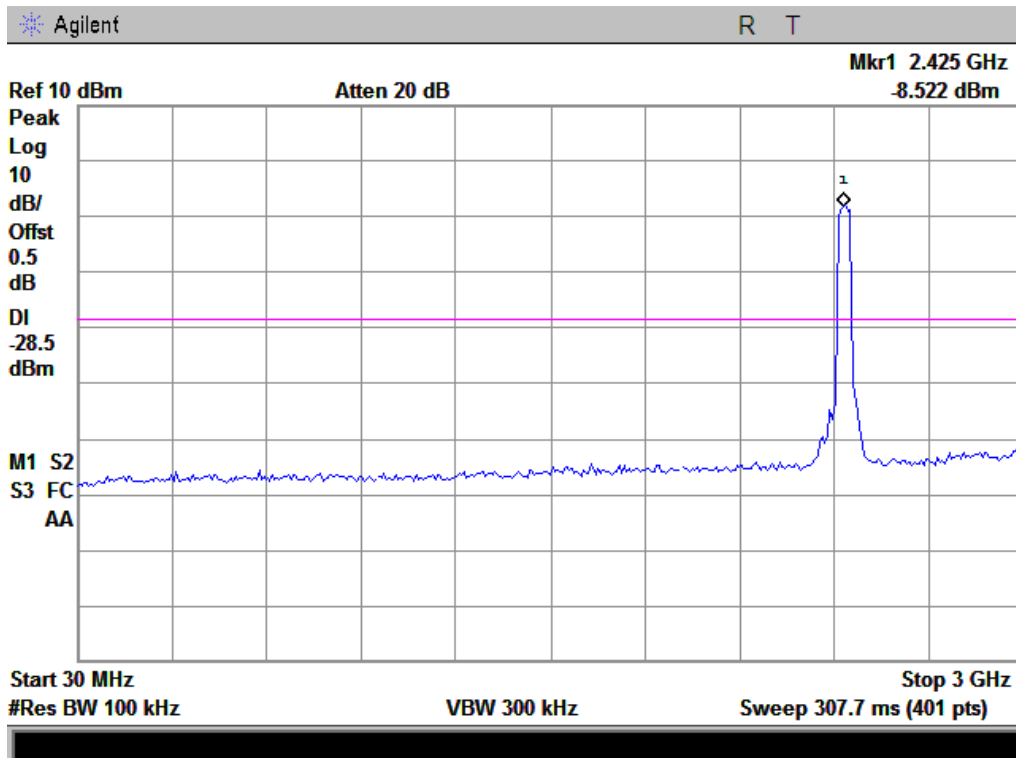
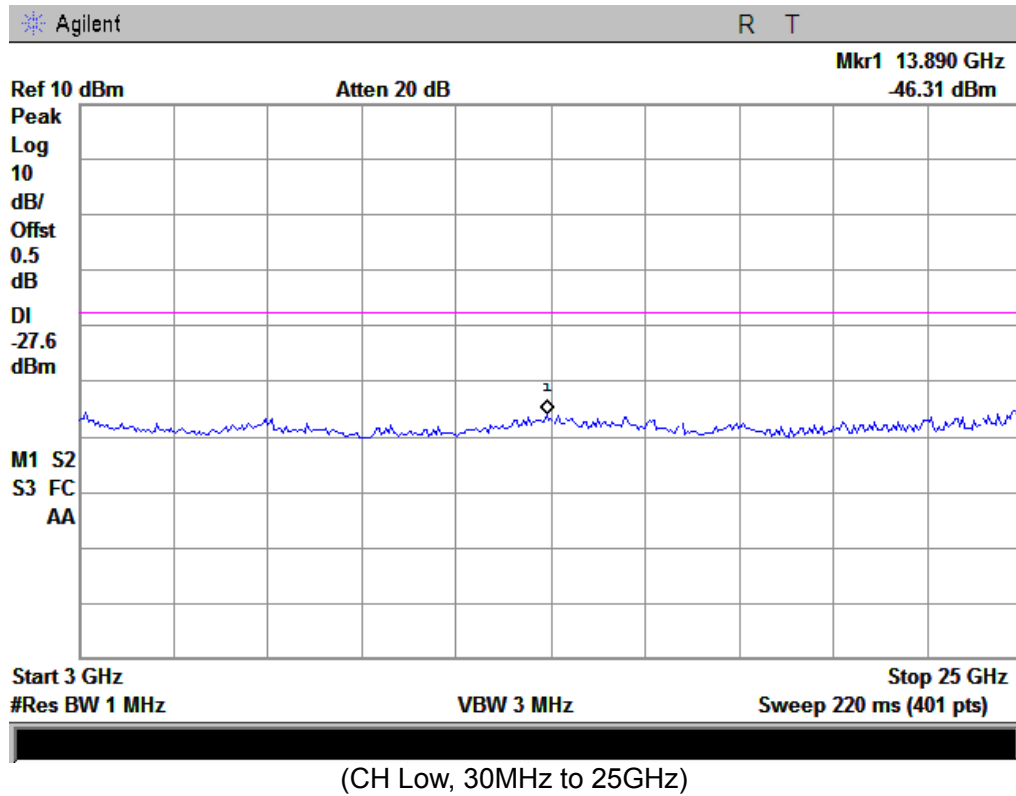

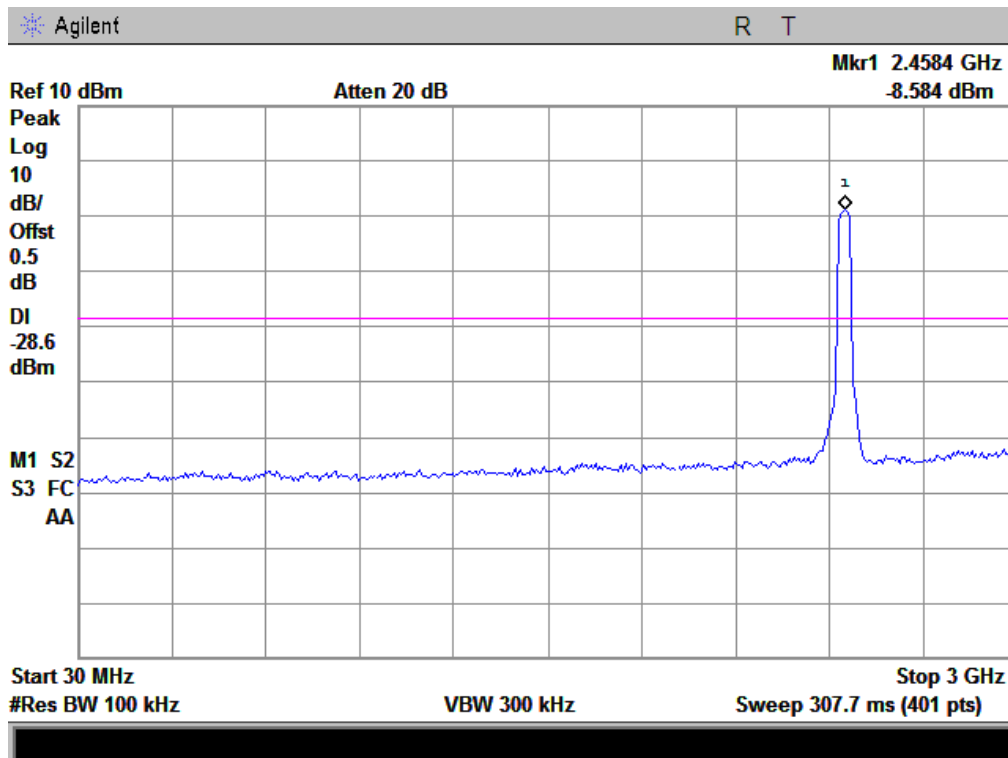
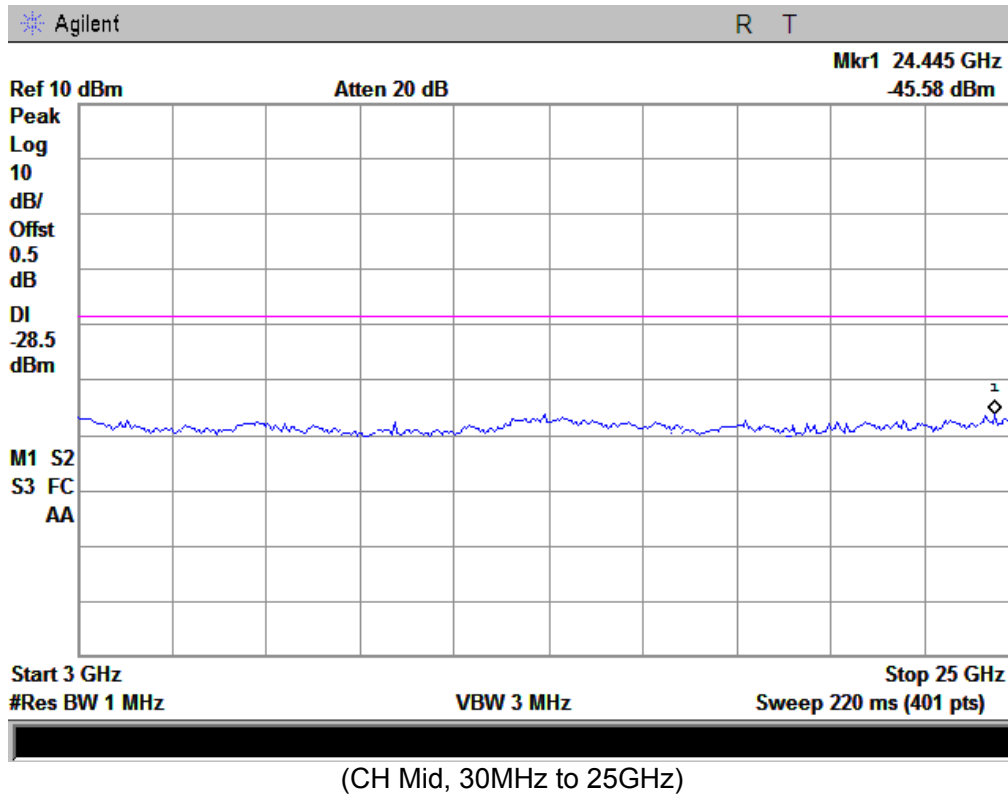



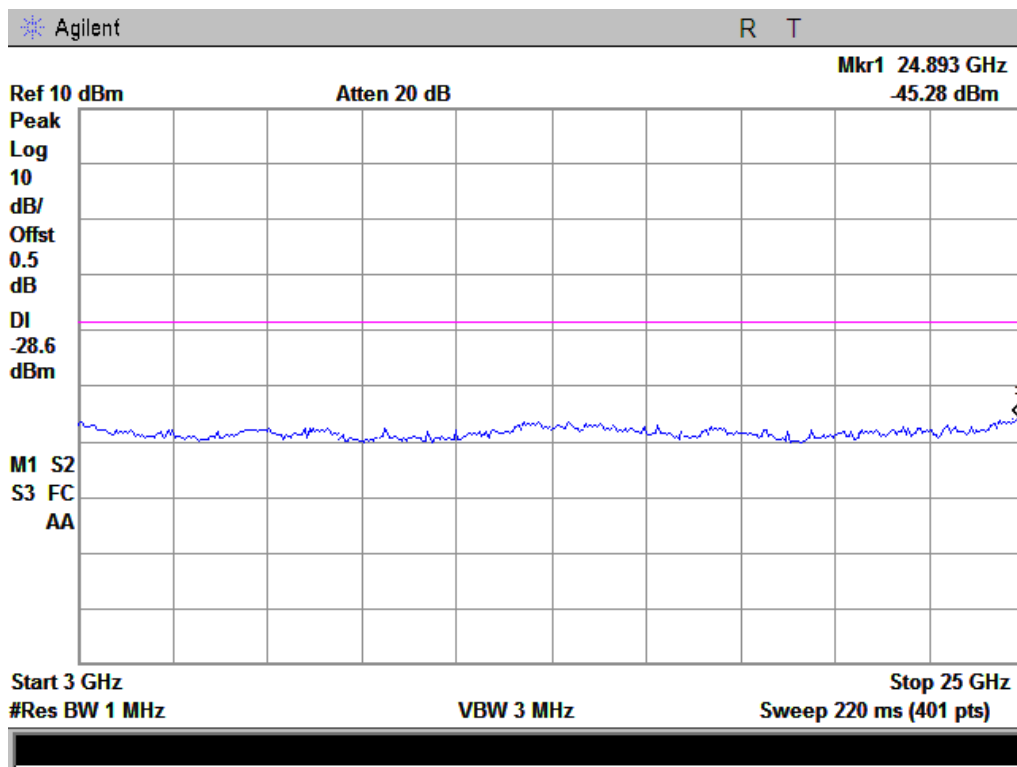

**Note:** The power of the Module transmitting frequency should be ignored.

### 5.4 Band Edge

#### 5.4.1 Definition

In any 100 kHz bandwidth outside the frequency band in which the spread spectrum or digitally modulated intentional radiator is operating, the radio frequency power that is produced by the intentional radiator shall be at least 20 dB below that in the 100 kHz bandwidth within the band that contains the highest level of the desired power, based on either an RF conducted or a radiated measurement, provided the transmitter demonstrates compliance with the peak conducted power limits.

#### 5.4.2 Test Description

See section 5.1.2 of this report.

#### 5.4.3 Test Result

The EUT operates at continuous transmit test mode. The test data of the lowest and highest channels are tested to verify the band edge emissions.

#### 802.11b Test Mode

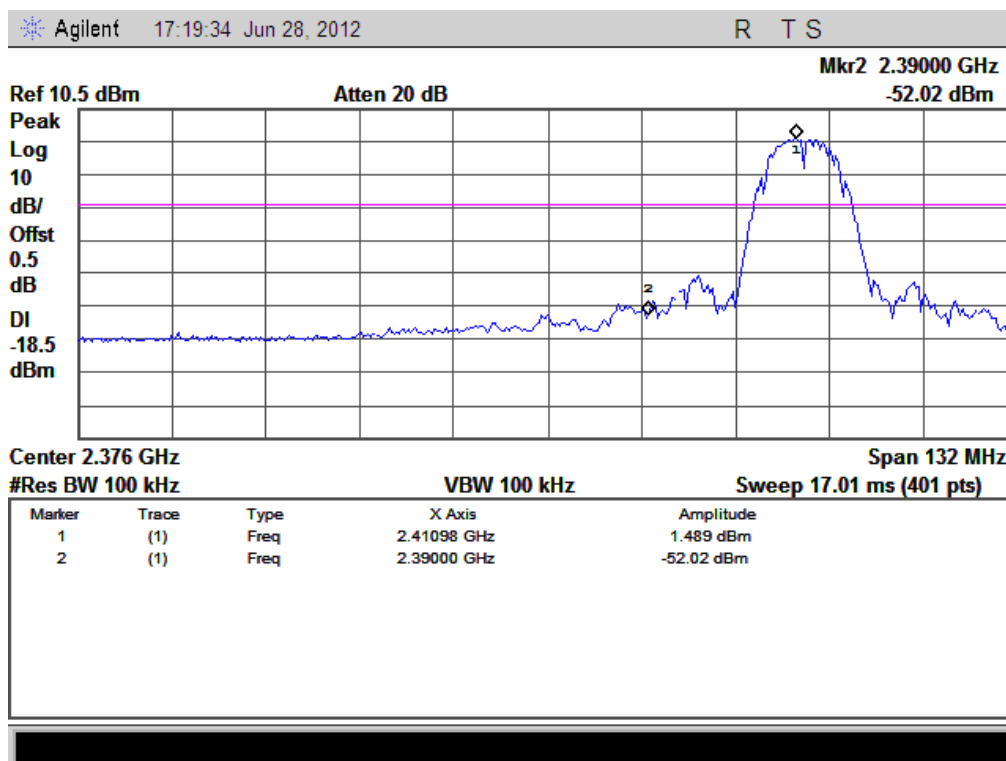

(CH Low)

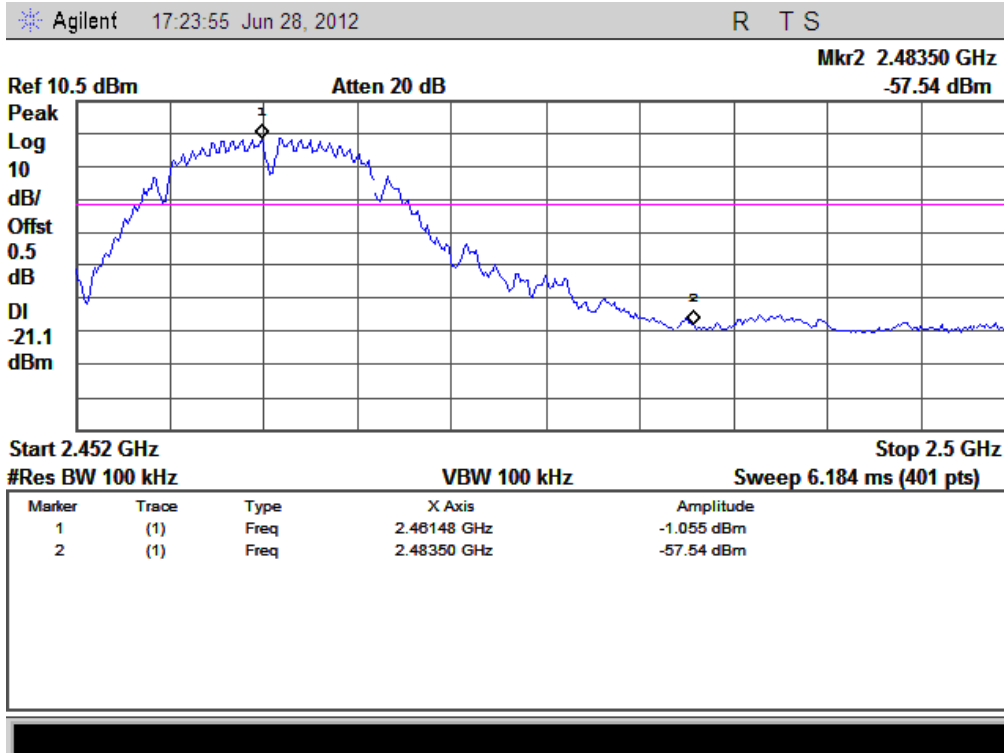

(CH High)

802.11g Test Mode

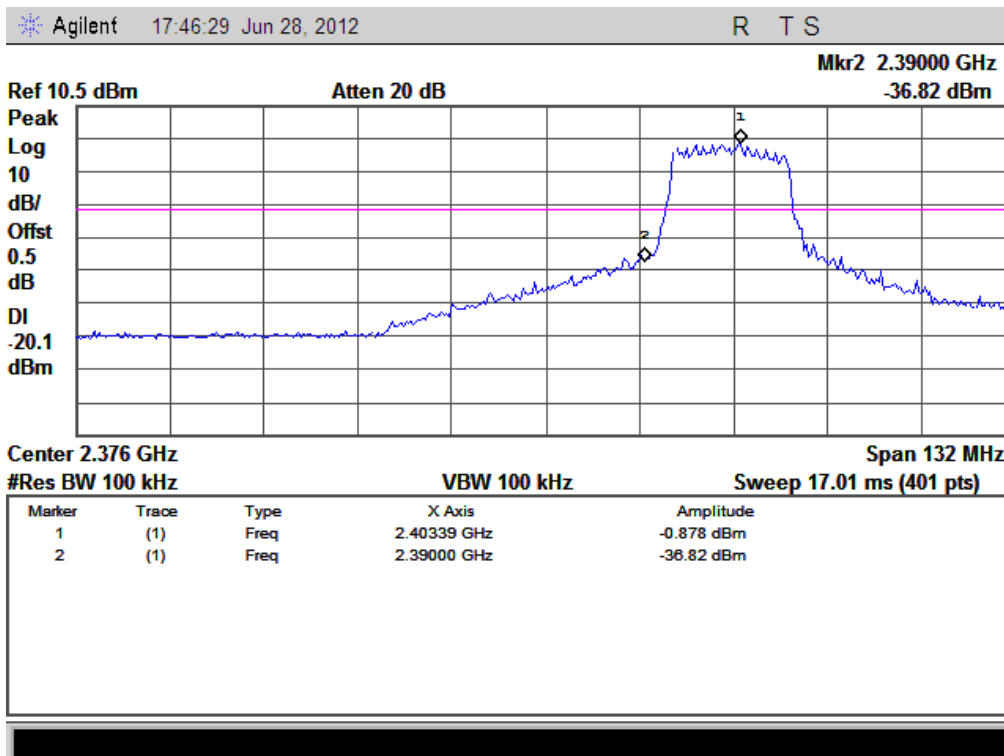

(CH Low)

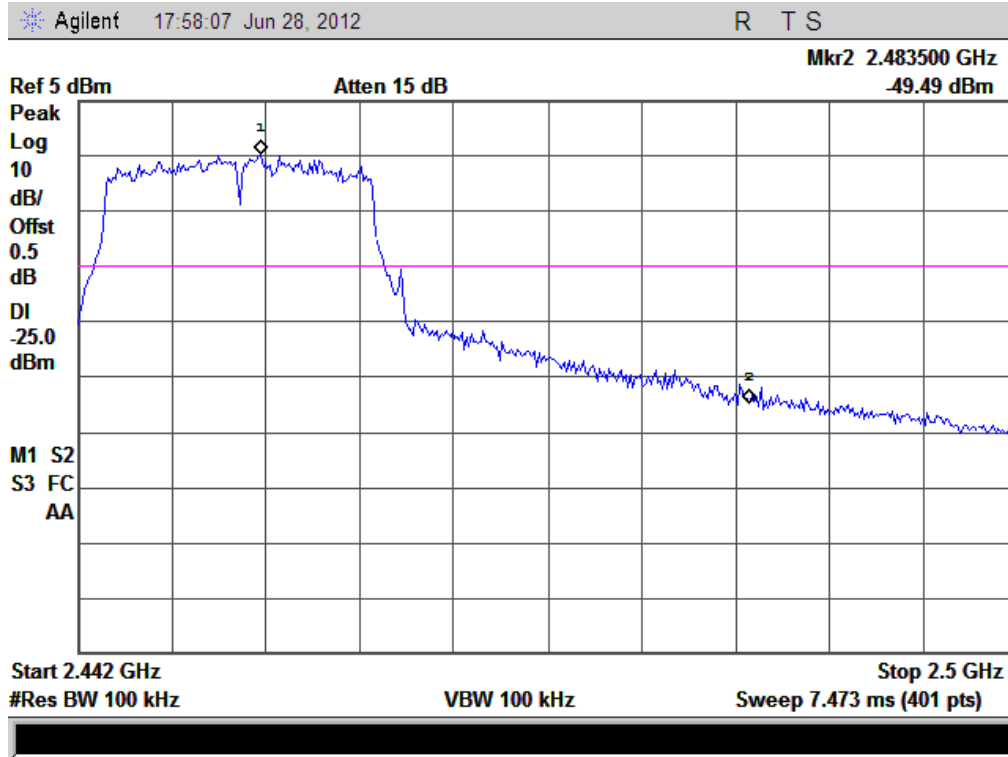

(CH High, Peak)

802.11n-40MHz Test Mode



(CH Low)

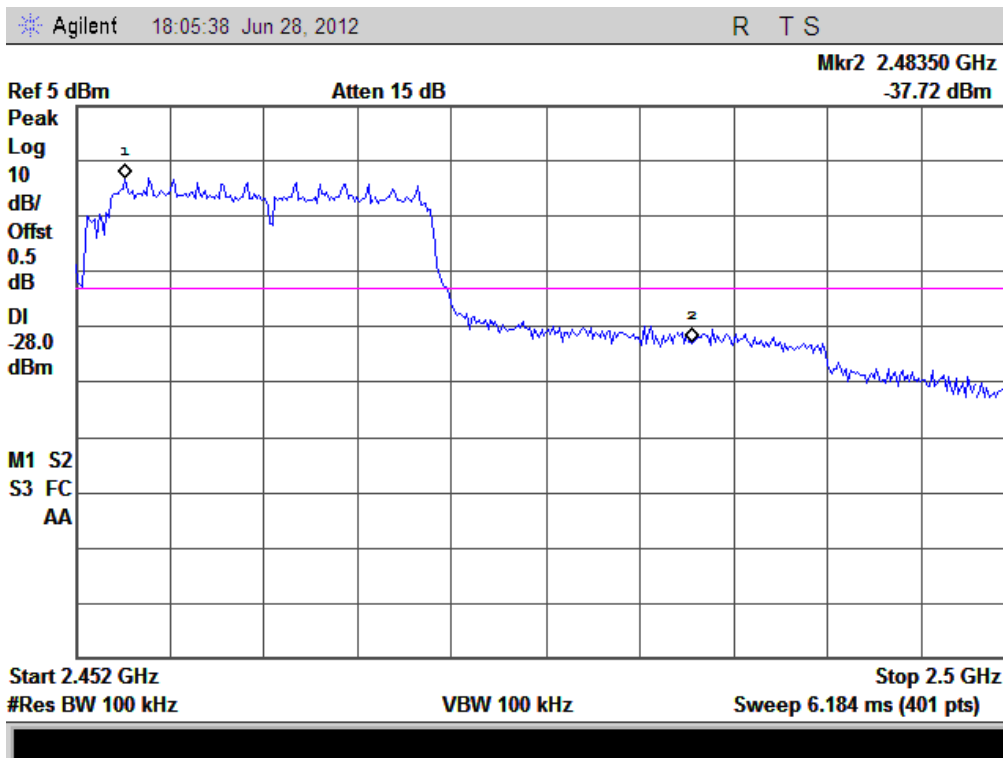

(CH High)

### 5.5 Power Spectral Density (PSD)

#### 5.5.1 Definition

For digitally modulated systems, the power spectral density conducted from the intentional radiator to the antenna shall not be greater than 8 dBm in any 3 kHz band during any time interval of continuous transmission.

#### 5.5.2 Test Description

See section 5.1.2 of this report.

#### 5.5.3 Test Result

The lowest, middle and highest channels are tested to verify the power spectral density.

#### 802.11b Test Mode

Channel	Frequency (MHz)	PSD (dBm)	Limits(dBm)	Result
1	2412	-10.75	≤8	PASS
6	2437	-12.53	≤8	PASS
11	2462	-12.31	≤8	PASS

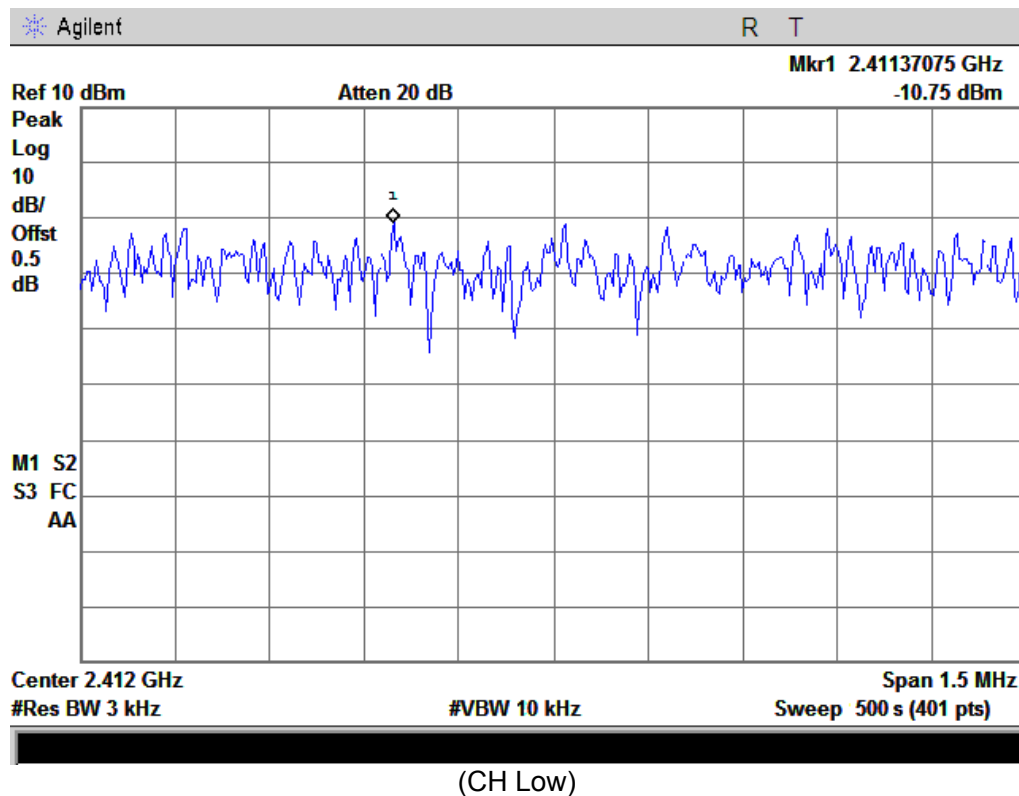

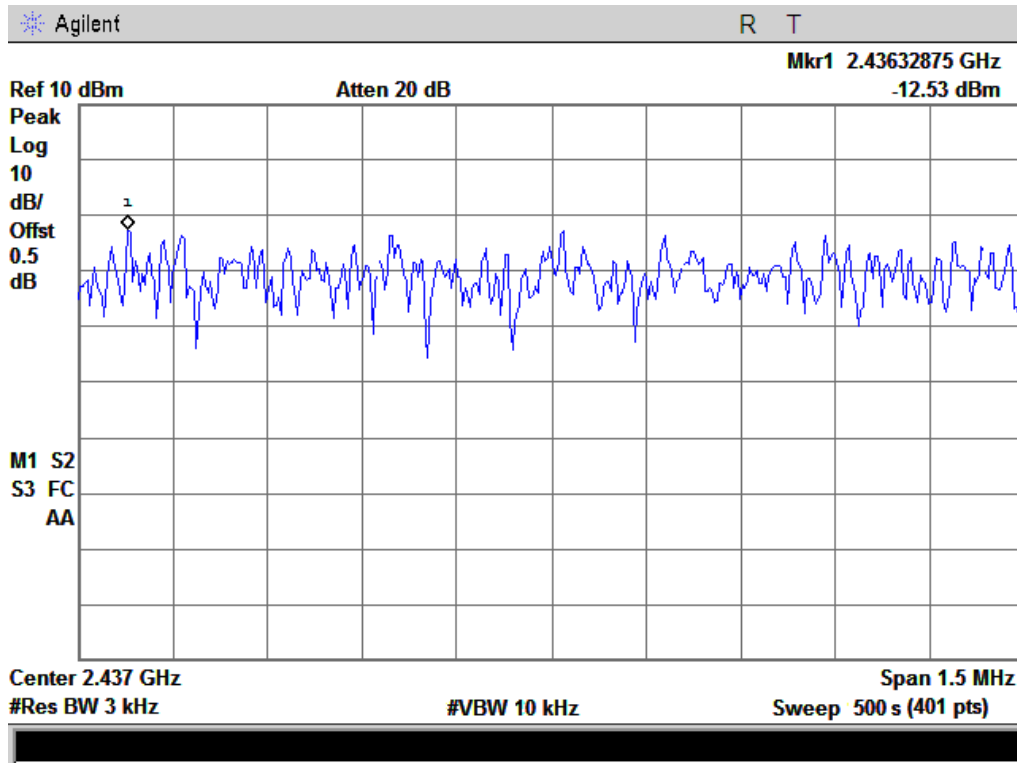

(CH Mid)

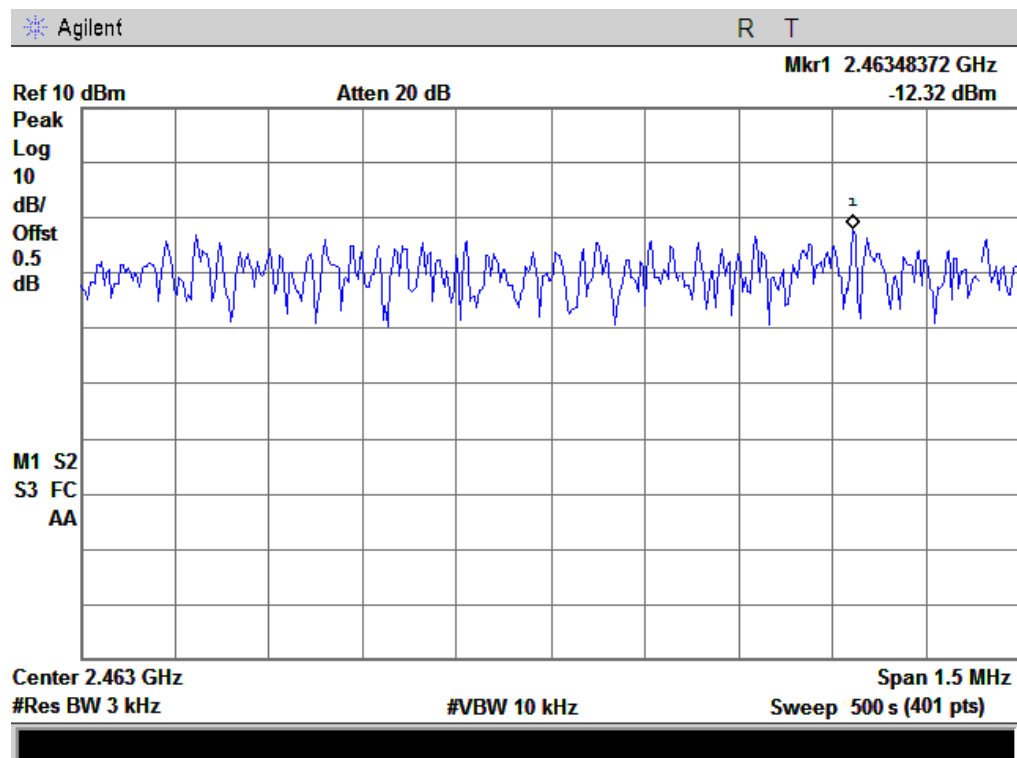

(CH High)

802.11g Test Mode

Channel	Frequency (MHz)	PSD (dBm)	Limits(dBm)	Result
1	2412	-14.21	≤8	PASS
6	2437	-16.33	≤8	PASS
11	2462	-16.25	≤8	PASS

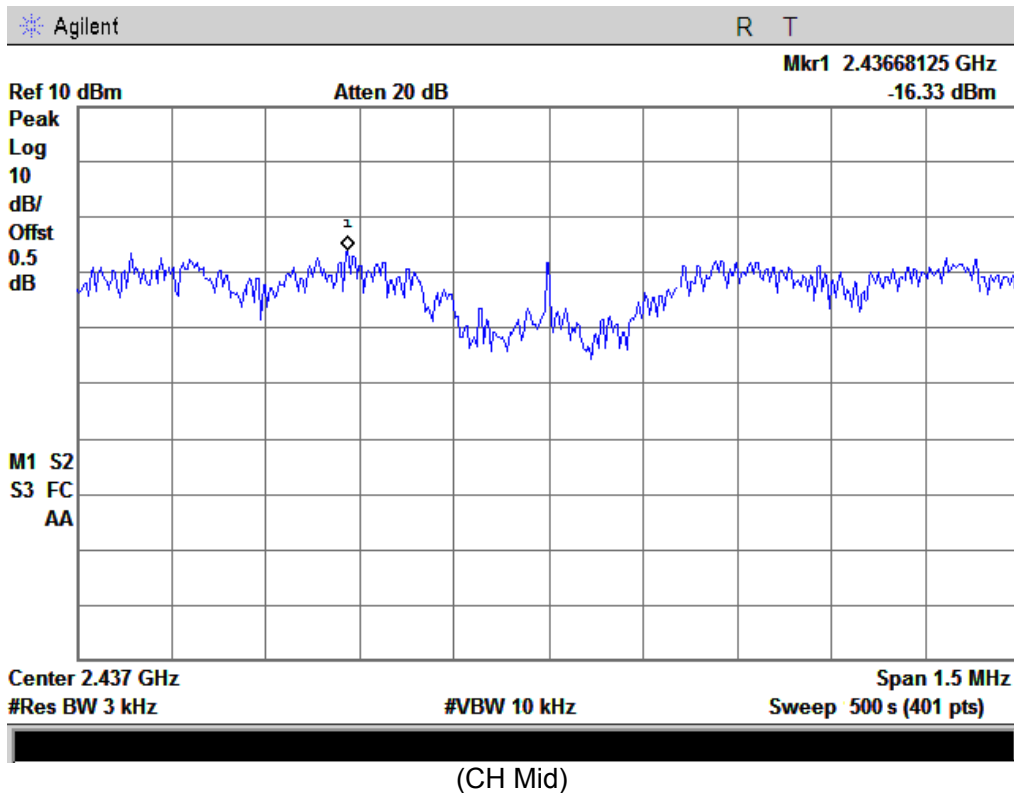
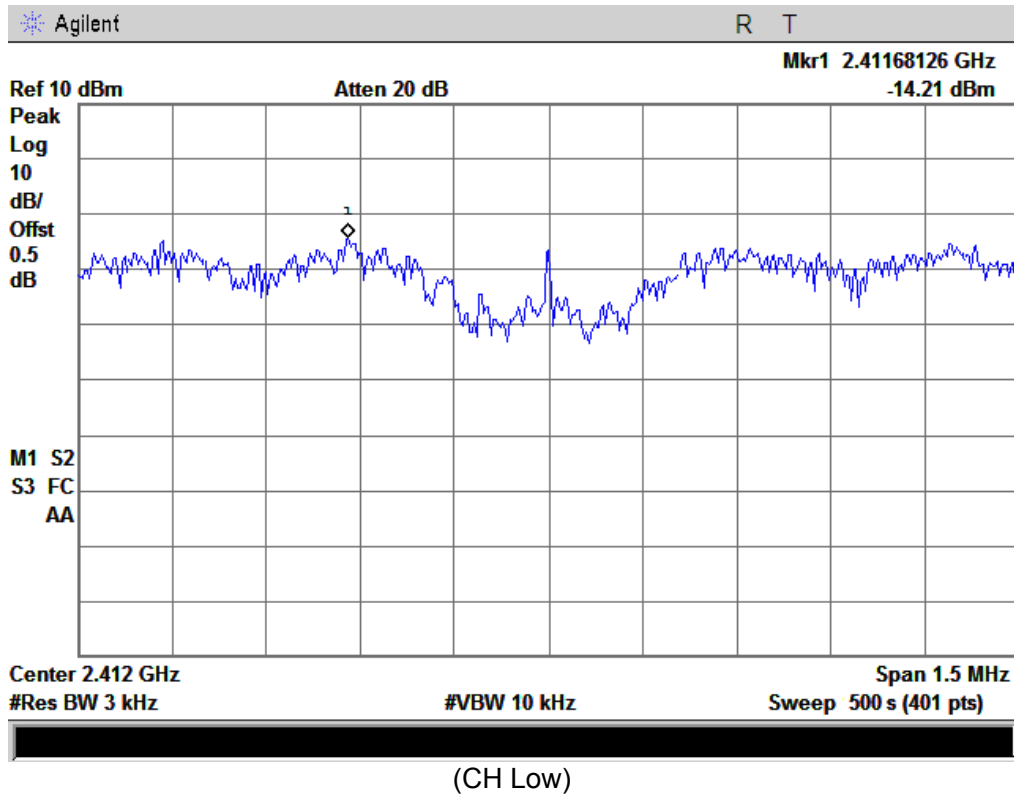



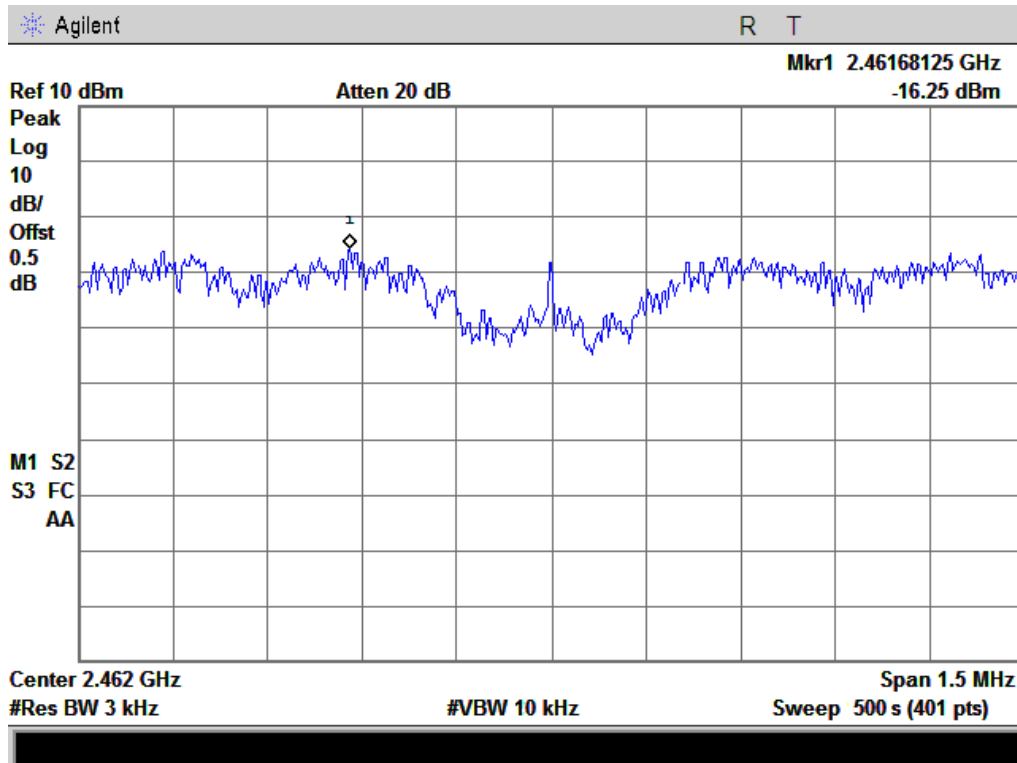

(CH High)

802.11n-40MHz Test Mode

Channel	Frequency (MHz)	PSD (dBm)	Limits(dBm)	Result
3	2422	-19.86	≤8	PASS
6	2437	-17.35	≤8	PASS
9	2452	-18.44	≤8	PASS

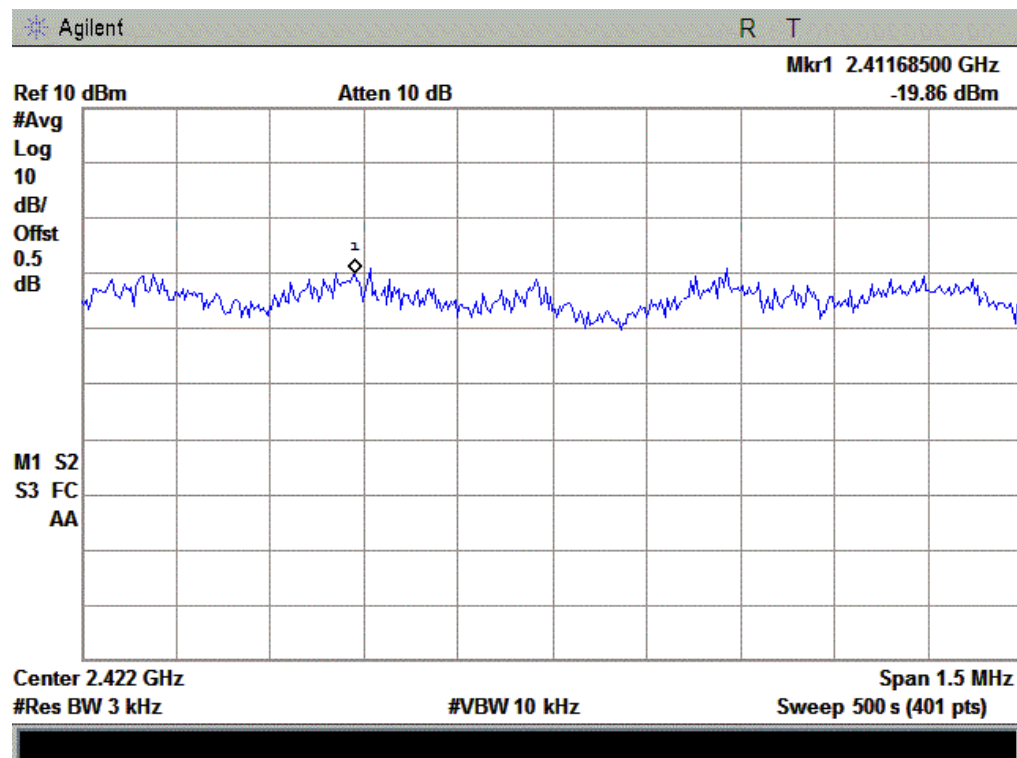

(CH Low)

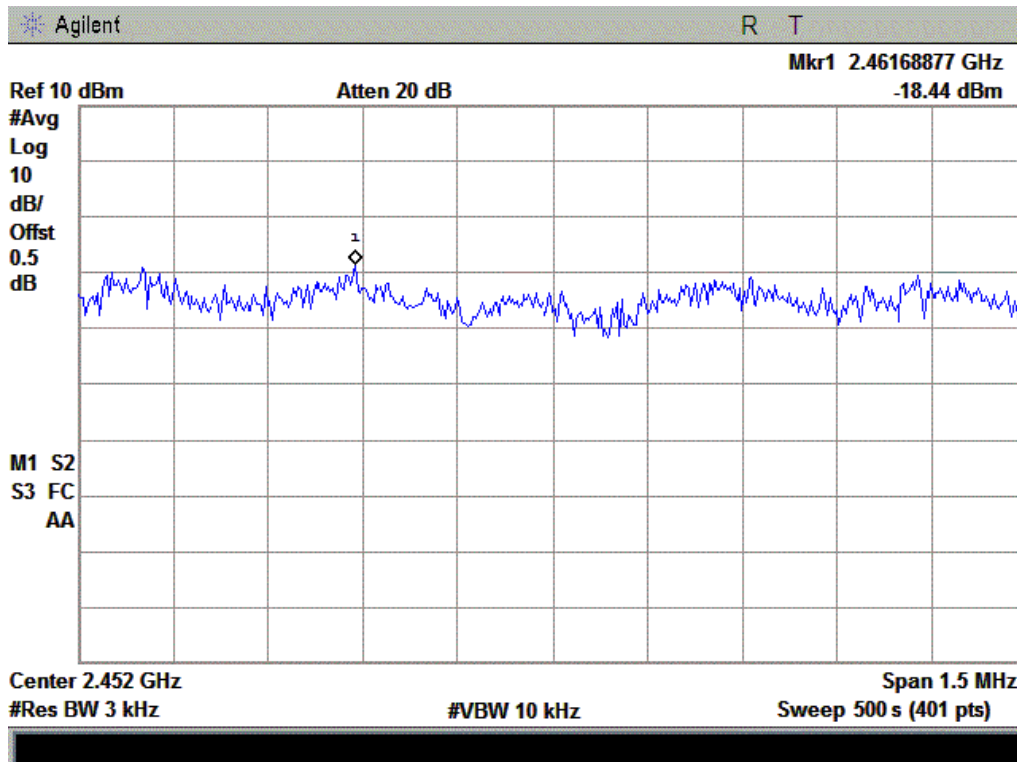
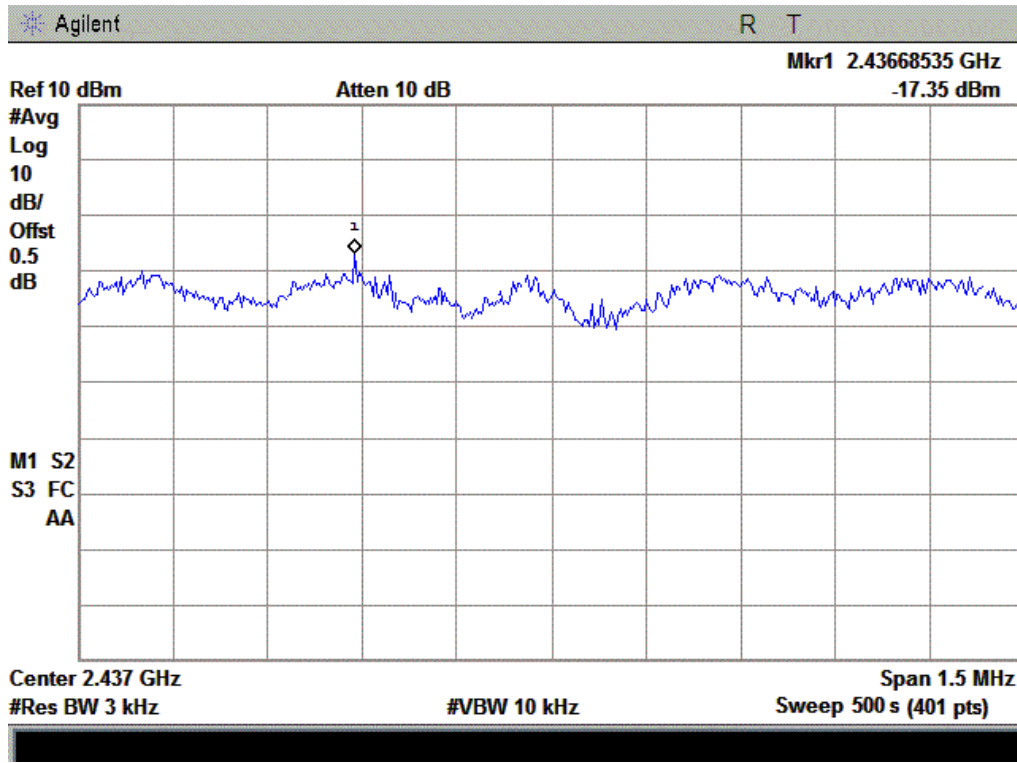

### 5.6 Conducted Emission

#### 5.6.1 Definition

According to FCC section 15.207, for an intentional radiator that is designed to be connected to the public utility (AC) power line, the radio frequency voltage that is conducted back onto the AC power line on any frequency or frequencies, within the band 150 kHz to 30 MHz, shall not exceed the limits in the following table, as measured using a 50 μH/50 ohms line impedance stabilization network (LISN).

Frequency	Maximum RF Line Voltage	
	Q.P.( dBuV)	Average( dBuV)
150kHz-500kHz	66-56	56-46
500kHz-5MHz	56	46
5MHz-30MHz	60	50

**Note:**

1. The lower limit shall apply at the transition frequency.
2. The limit decreases linearly with the logarithm of the frequency in the range 0.15 MHz to 0.50 MHz

#### 5.6.2 Test Description

The EUT is powered by the Battery charged with the AC Adapter which is powered by 120V, 60Hz AC mains supply. The path loss as the factor is calibrated to correct the reading. During the measurement, the EUT is activated and is set to operate at maximum power.

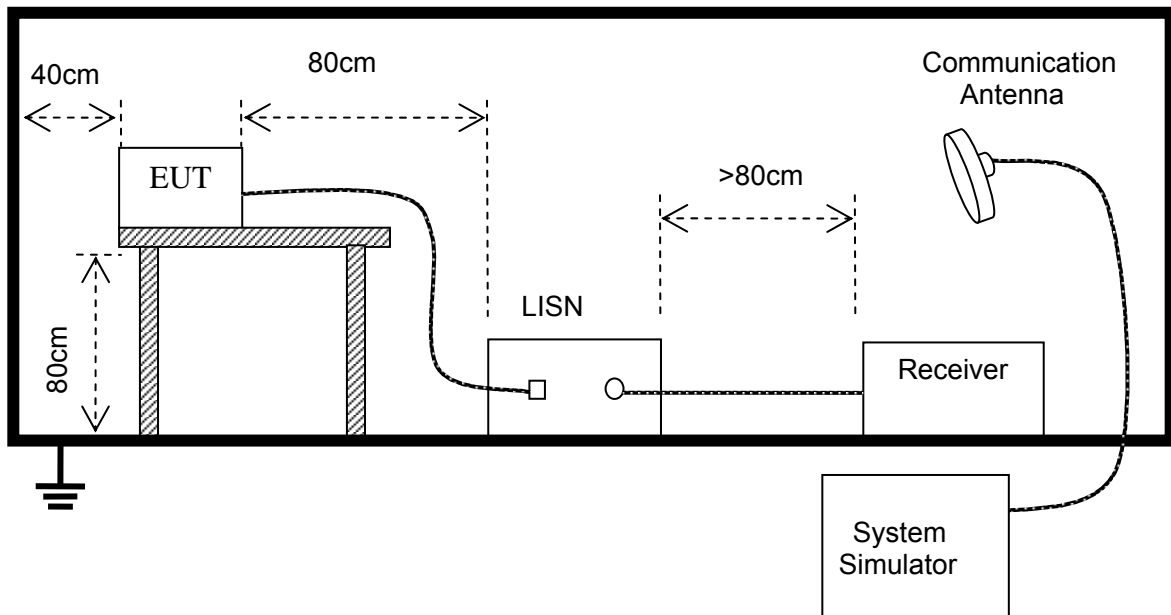

### 5.6.3 Test Result

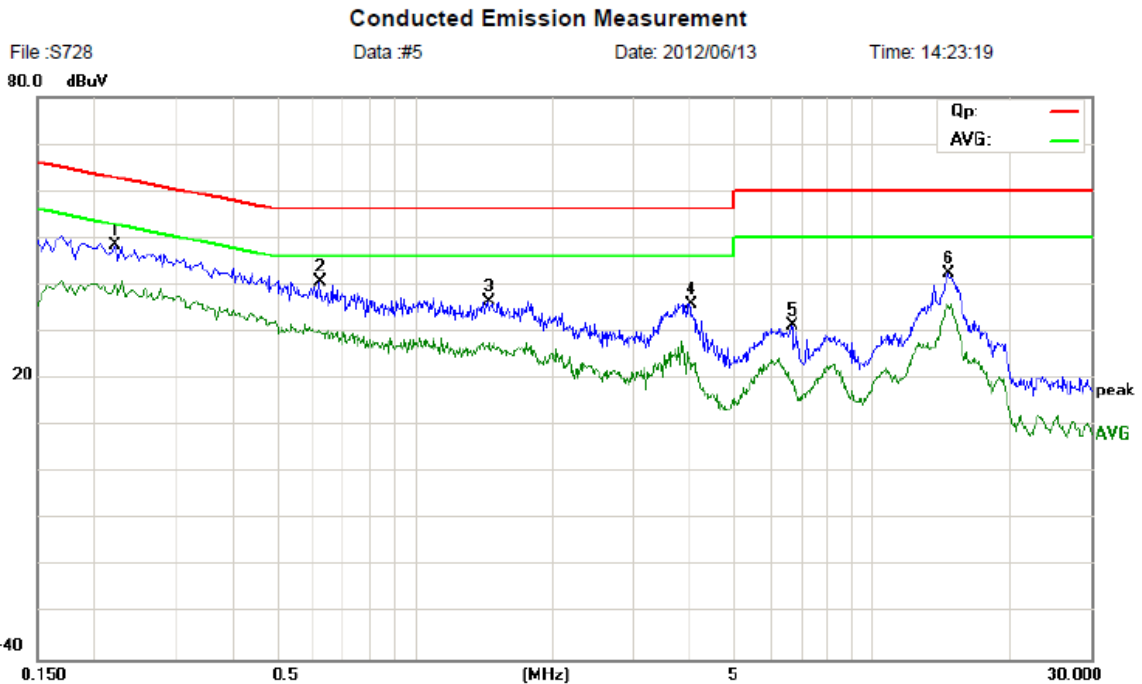

Site site #1                      Phase: **L1**                      Temperature: 26  
 Limit: FCC Part15 B Class B QP                      Power: 1                      Humidity: 60 %  
 EUT:  
 M/N: S728  
 Mode: WiFi  
 Note:

No.	Mk.	Freq. MHz	Reading Level dBuV	Correct Factor dB	Measure- ment dBuV	Limit dBuV	Over dB	Detector	Comment
1	*	0.2220	36.58	11.85	48.43	62.74	-14.31	peak	
2		0.6180	30.47	10.00	40.47	56.00	-15.53	peak	
3		1.4460	26.75	9.55	36.30	56.00	-19.70	peak	
4		3.9900	24.90	10.99	35.89	56.00	-20.11	peak	
5		6.6300	20.21	11.02	31.23	60.00	-28.77	peak	
6		14.6180	33.23	9.00	42.23	60.00	-17.77	peak	

\*:Maximum data    x:Over limit    l:over margin

Conducted Emission Measurement

File :S728

Data :#6

Date: 2012/06/13

Time: 14:24:12

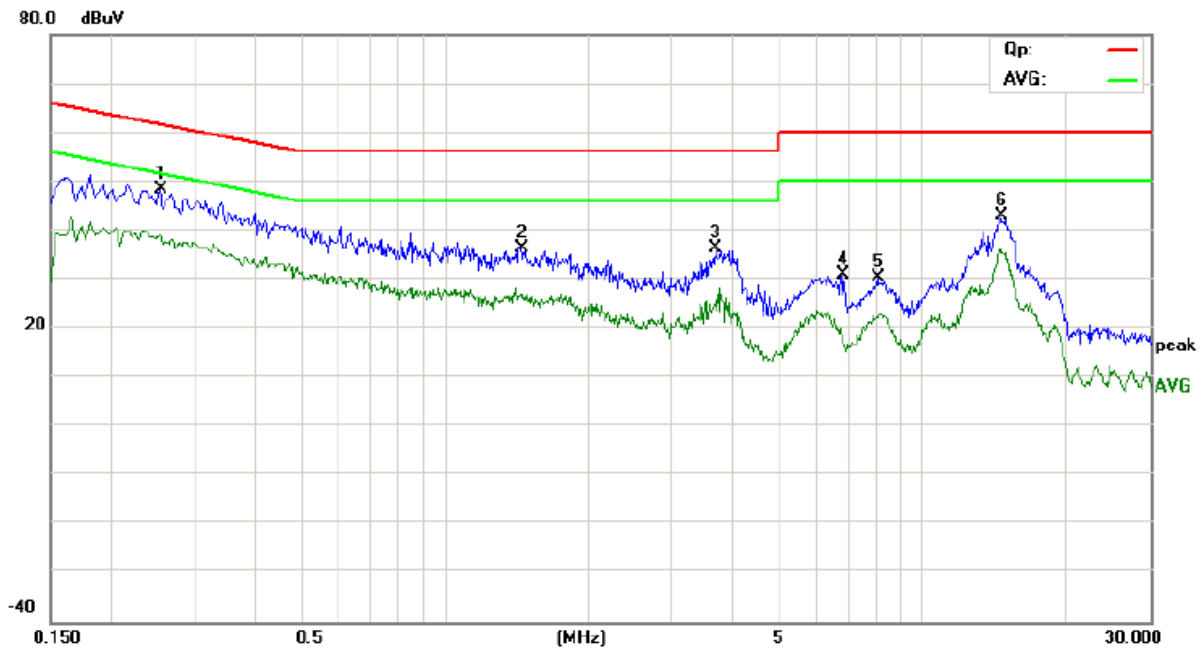

Site site #1

Phase: N

Temperature: 26

Limit: FCC Part15 B Class B QP

Power: 1

Humidity: 60 %

EUT:

M/N: S728

Mode: WiFi

Note:

No.	Mk.	Freq. MHz	Reading Level dBuV	Correct Factor dB	Measure- ment dBuV	Limit dBuV	Over dB	Detector	Comment
1	*	0.2540	36.59	11.64	48.23	61.63	-13.40	peak	
2		1.4460	26.75	9.55	36.30	56.00	-19.70	peak	
3		3.6900	25.53	10.69	36.22	56.00	-19.78	peak	
4		6.8180	20.00	10.91	30.91	60.00	-29.09	peak	
5		8.0940	20.11	10.14	30.25	60.00	-29.75	peak	
6		14.5260	33.83	9.00	42.83	60.00	-17.17	peak	

\*:Maximum data x:Over limit !:over margin

## 5.7 Radiated Emission

### 5.7.1 Definition

According to FCC section 15.247(d), radiated emission outside the frequency band attenuation below the general limits specified in § 15.209(a) is not required. In addition, radiated emissions which fall in the restricted bands, as defined in § 15.205(a), must also comply with the radiated emission limits specified in § 15.209(a) (see § 15.205(c)).

According to FCC section 15.209 (a), except as provided elsewhere in this subpart, the emissions from an intentional radiator shall not exceed the field strength levels specified in the following table:

Frequency (MHz)	Field Strength ( $\mu\text{V}/\text{m}$ )	Measurement Distance (m)
0.009 - 0.490	2400/F(kHz)	300
0.490 - 1.705	24000/F(kHz)	30
1.705 - 30.0	30	30
30 - 88	100	3
88 - 216	150	3
216 - 960	200	3
Above 960	500	3

As shown in FCC section 15.35(b), for frequencies above 1000MHz, the field strength limits are based on average detector. When average radiated emission measurements are specified in this part, including emission measurements below 1000MHz, there also is a limit on the radio frequency emissions, as measured using instrumentation with a peak detector function, corresponding to 20dB above the maximum permitted average limit for the frequency being investigated unless a different peak emission limit is otherwise specified in the rules.

### 5.7.2 Test Description

#### A. Test Setup:

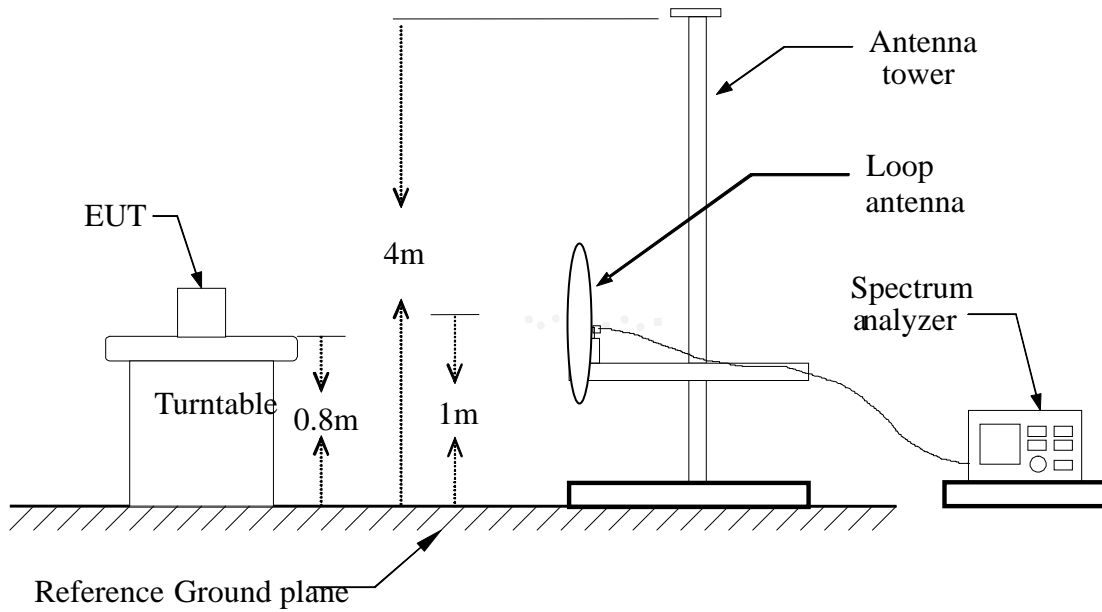

#### Blow 1GHz:

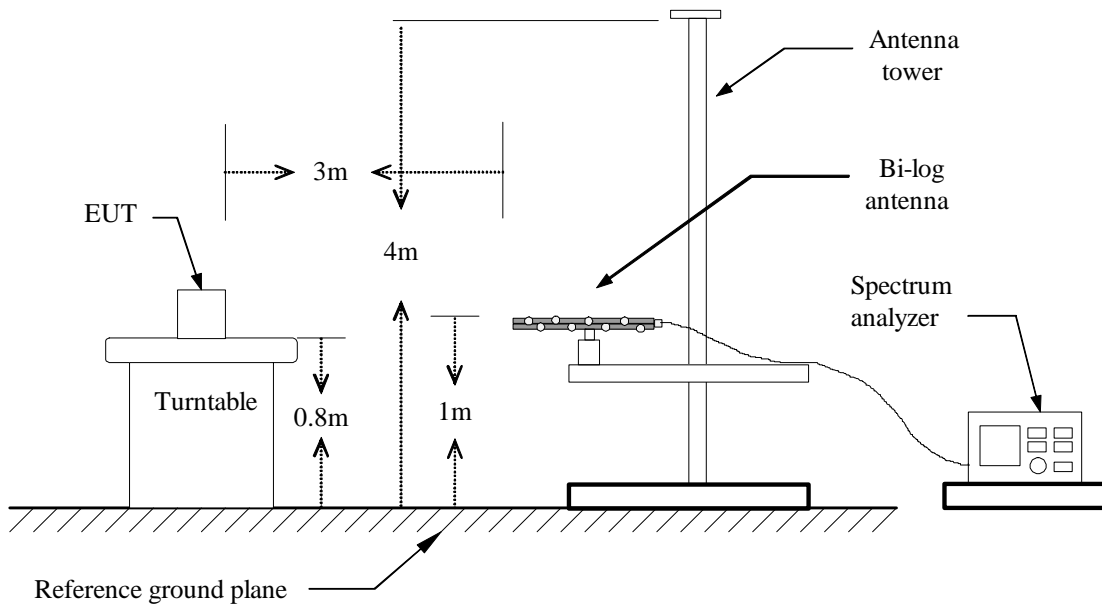

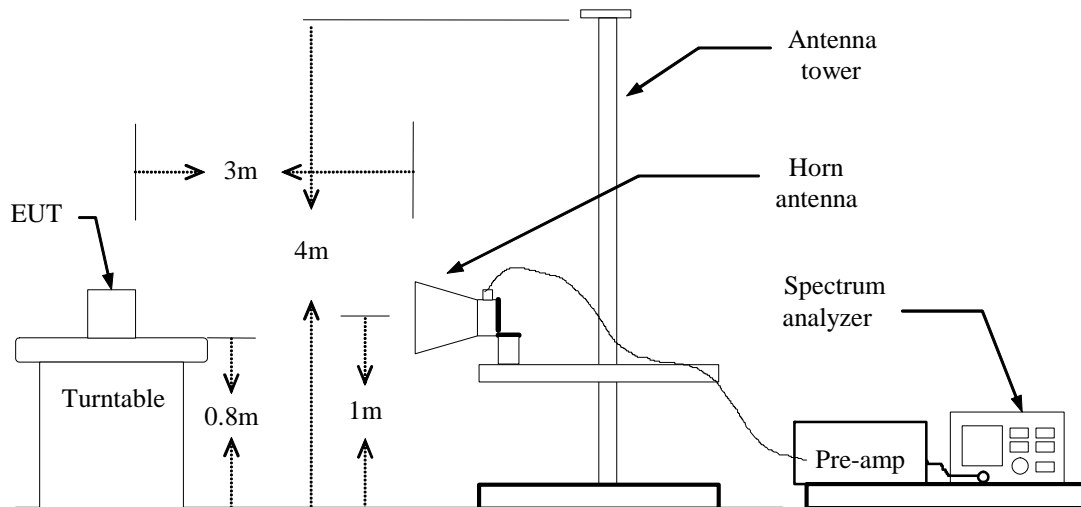
**Above 1GHz:****B. Test procedures**

1. The EUT is placed on a turntable, which is 0.8m above ground plane.
2. The turntable shall be rotated for 360 degrees to determine the position of maximum emission level.
3. EUT is set 3m away from the receiving antenna, which is varied from 1m to 4m to find out the highest emissions.
4. Maximum procedure was performed on the six highest emissions to ensure EUT compliance.
5. And also, each emission was to be maximized by changing the polarization of receiving antenna both horizontal and vertical.
6. Set the spectrum analyzer in the following setting as:
  - Below 1GHz: RBW=100 kHz / VBW=300 kHz / Sweep=AUTO
  - Above 1GHz : (a) PEAK: RBW=VBW=1MHz / Sweep=AUTO
  - (b) AVERAGE: RBW=1MHz / VBW=1MHz / Sweep=AUTO
7. Repeat above procedures until the measurements for all frequencies are complete.



**5.7.3 Test Result**

Form 9 KHz to 30MHz:

Freq. (MHz)	Ant. Pol H/V	Peak Reading (dBuV)	Ant. / CL CF (dB)	Actual Fs Peak (dBuV/m)	Peak Limit (dBuV/m)	Peak Margin (dB)
	H					
	H					
	H					
N/A						>20
	V					
	V					
	V					
N/A						>20

**-Note: No test data was detected in below 30MHz.**



**Radiated Emission Measurement**

File :S728

Data :#10

Date: 2012-6-13

Time: 21:40:43

70.0 dBuV/m

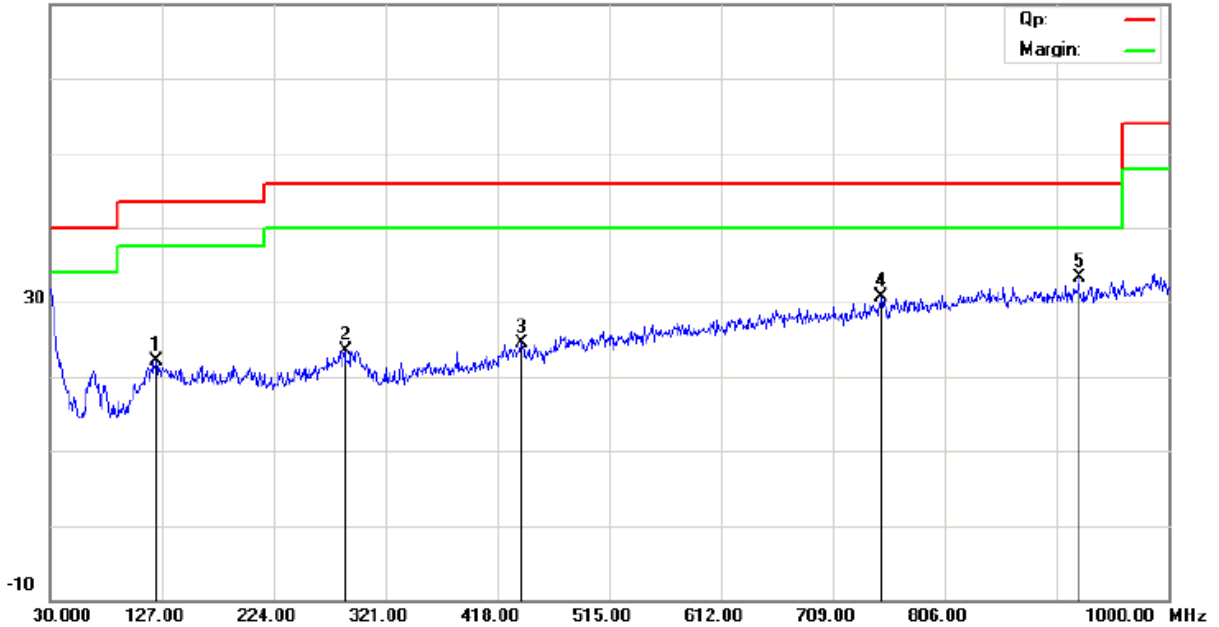

Site site #1 Polarization: *Horizontal* Temperature: 26  
 Limit: FCC Part15 B 3M Radiation Power: AC 120V/60Hz Humidity: 61 %  
 EUT: GSM MOBILE PHONE Distance:  
 M/N: S728  
 Mode: WiFi  
 Note:

No.	Mk.	Freq.	Reading Level	Correct Factor	Measurement	Limit	Over	Antenna Height	Table Degree	Comment
		MHz	dBuV	dB	dBuV/m	dBuV/m	dB	cm	degree	
1		122.1500	4.49	17.59	22.08	43.50	-21.42	peak	0	
2		286.0800	4.12	19.44	23.56	46.00	-22.44	peak	0	
3		439.3400	4.11	20.30	24.41	46.00	-21.59	peak	0	
4		750.7100	4.88	25.79	30.67	46.00	-15.33	peak	0	
5	*	922.4000	5.65	27.58	33.23	46.00	-12.77	peak	0	

\*:Maximum data x:Over limit l:over margin

**Above 1 GHz**

**Operation Mode:** TX/ IEEE 802.11b/CH Low      **Test Date:** 2012-06-13  
**Temperature:** 20°C      **Humidity:** 70 % RH

Freq. (MHz)	Ant. Pol H/V	Peak Reading dBuV	AV Reading dBuV	Ant. / CL CF dB)	Actual Fs		Peak Limit dBuV/m	AV Limit dBuV/m	AV Margin dB
					Peak dBuV/m	AV dBuV/m			
4824.5	V	46.08	25.48	23.05	69.13	48.53	74.00	54.00	-5.47
N/A	H								
4824.5	H	42.24	24.29	23.05	65.29	47.34	74.00	54.00	-6.66
N/A	H								

**Notes:**

1. Measuring frequencies from 1 GHz to the 10th harmonic of highest fundamental frequency.
2. Radiated emissions measured in frequency above 1000MHz were made with an instrument using peak/average detector mode.
3. Average test would be performed if the peak result were greater than the average limit or as required by the applicant.
4. Data of measurement within this frequency range shown " --- " in the table above means the reading of emissions are attenuated more than 20dB below the permissible limits or the field strength is too small to be measured.
5. Measurements above show only up to 6 maximum emissions noted, or would be lesser, with " N/A " remark, if no specific emissions from the EUT are recorded (ie: margin>20dB from the applicable limit) and considered that's already beyond the background noise floor.
6. Margin (dB) = Remark result (dBuV/m) – Average limit (dBuV/m).

**Operation Mode:** TX/ IEEE 802.11b/CH Mid

**Test Date:** 2012-06-13

**Temperature:** 20°C

**Humidity:** 70 % RH

Freq. (MHz)	Ant. Pol H/V	Peak Reading dBuV	AV Reading dBuV	Ant. / CL CF dB	Actual Fs		Peak Limit dBuV/m	AV Limit dBuV/m	AV Margin dB
					Peak dBuV/m	AV dBuV/m			
4874.50	V	44.18	23.03	23.98	68.16	47.01	74.00	54.00	-6.99
N/A	V								
4874.50	H	45.36	22.78	23.98	69.34	46.76	74.00	54.00	-7.24
N/A	H								

**Notes:**

1. Measuring frequencies from 1 GHz to the 10th harmonic of highest fundamental frequency.
2. Radiated emissions measured in frequency above 1000MHz were made with an instrument using peak/average detector mode.
3. Average test would be performed if the peak result were greater than the average limit or as required by the applicant.
4. Data of measurement within this frequency range shown " --- " in the table above means the reading of emissions are attenuated more than 20dB below the permissible limits or the field strength is too small to be measured.
5. Measurements above show only up to 6 maximum emissions noted, or would be lesser, with " N/A " remark, if no specific emissions from the EUT are recorded (ie: margin>20dB from the applicable limit) and considered that's already beyond the background noise floor.
6. Margin (dB) = Remark result (dBuV/m) – Average limit (dBuV/m).

**Operation Mode:** TX/ IEEE 802.11b/CH High

**Test Date:** 2012-06-13

**Temperature:** 20°C

**Humidity:** 70 % RH

Freq. (MHz)	Ant. Pol H/V	Peak Reading dBuV	AV Reading dBuV	Ant. / CL CF dB	Actual Fs		Peak Limit dBuV/m	AV Limit dBuV/m	AV Margin dB
					Peak dBuV/m	AV dBuV/m			
4924.50	V	43.68	23.08	24.86	68.54	47.94	74.00	54.00	-6.06
N/A	V								
4924.50	H	42.53	20.45	24.86	67.39	45.31	74.00	54.00	-8.69
N/A	H								

**Notes:**

1. Measuring frequencies from 1 GHz to the 10th harmonic of highest fundamental frequency.
2. Radiated emissions measured in frequency above 1000MHz were made with an instrument using peak/average detector mode.
3. Average test would be performed if the peak result were greater than the average limit or as required by the applicant.
4. Data of measurement within this frequency range shown “ --- ” in the table above means the reading of emissions are attenuated more than 20dB below the permissible limits or the field strength is too small to be measured.
5. Measurements above show only up to 6 maximum emissions noted, or would be lesser, with “ N/A ” remark, if no specific emissions from the EUT are recorded (ie: margin>20dB from the applicable limit) and considered that's already beyond the background noise floor.
6. Margin (dB) = Remark result (dBuV/m) – Average limit (dBuV/m).

**Operation Mode:** TX/ IEEE 802.11g/CH Low

**Test Date:** 2012-06-13

**Temperature:** 20°C

**Humidity:** 70 % RH

Freq. (MHz)	Ant. Pol H/V	Peak Reading dBuV	AV Reading dBuV	Ant. / CL CF dB)	Actual Fs		Peak Limit dBuV/m	AV Limit dBuV/m	AV Margin dB
					Peak dBuV/m	AV dBuV/m			
4824.5	V	45.14	26.28	23.05	68.19	49.33	74.00	54.00	-4.67
N/A	V								
4824.5	H	44.62	25.27	23.05	67.67	48.32	74.00	54.00	-5.68
N/A	H								

**Notes:**

1. Measuring frequencies from 1 GHz to the 10th harmonic of highest fundamental frequency.
2. Radiated emissions measured in frequency above 1000MHz were made with an instrument using peak/average detector mode.
3. Average test would be performed if the peak result were greater than the average limit or as required by the applicant.
4. Data of measurement within this frequency range shown “ --- ” in the table above means the reading of emissions are attenuated more than 20dB below the permissible limits or the field strength is too small to be measured.
5. Measurements above show only up to 6 maximum emissions noted, or would be lesser, with “ N/A ” remark, if no specific emissions from the EUT are recorded (ie: margin>20dB from the applicable limit) and considered that's already beyond the background noise floor.
6. Margin (dB) = Remark result (dBuV/m) – Average limit (dBuV/m).

**Operation Mode:** TX/ IEEE 802.11g/CH Mid

**Test Date:** 2012-06-13

**Temperature:** 20°C

**Humidity:** 70 % RH

Freq. (MHz)	Ant. Pol H/V	Peak Reading dBuV	AV Reading dBuV	Ant. / CL CF dB)	Actual Fs		Peak Limit dBuV/m	AV Limit dBuV/m	AV Margin dB
					Peak dBuV/m	AV dBuV/m			
4874.50	V	45.36	24.67	23.98	69.34	48.65	74.00	54.00	-5.35
N/A	V								
4874.50	H	43.95	22.13	23.98	67.93	46.11	74.00	54.00	-7.89
N/A	H								

**Notes:**

1. Measuring frequencies from 1 GHz to the 10th harmonic of highest fundamental frequency.
2. Radiated emissions measured in frequency above 1000MHz were made with an instrument using peak/average detector mode.
3. Average test would be performed if the peak result were greater than the average limit or as required by the applicant.
4. Data of measurement within this frequency range shown “ --- ” in the table above means the reading of emissions are attenuated more than 20dB below the permissible limits or the field strength is too small to be measured.
5. Measurements above show only up to 6 maximum emissions noted, or would be lesser, with “ N/A ” remark, if no specific emissions from the EUT are recorded (ie: margin>20dB from the applicable limit) and considered that's already beyond the background noise floor.
6. Margin (dB) = Remark result (dBuV/m) – Average limit (dBuV/m).



**Operation Mode:** TX/ IEEE 802.11g/CH High

**Test Date:** 2012-06-13

**Temperature:** 20°C

**Humidity:** 70 % RH

Freq. (MHz)	Ant. Pol H/V	Peak Reading dBuV	AV Reading dBuV	Ant. / CL CF dB)	Actual Fs		Peak Limit dBuV/m	AV Limit dBuV/m	AV Margin dB
					Peak dBuV/m	AV dBuV/m			
4924.50	V	44.28	24.11	24.86	69.14	48.97	74.00	54.00	-5.03
N/A	V								
4924.50	H	43.77	22.70	24.86	68.63	47.56	74.00	54.00	-6.44
N/A	H								

**Notes:**

1. Measuring frequencies from 1 GHz to the 10th harmonic of highest fundamental frequency.
2. Radiated emissions measured in frequency above 1000MHz were made with an instrument using peak/average detector mode.
3. Average test would be performed if the peak result were greater than the average limit or as required by the applicant.
4. Data of measurement within this frequency range shown “ --- ” in the table above means the reading of emissions are attenuated more than 20dB below the permissible limits or the field strength is too small to be measured.
5. Measurements above show only up to 6 maximum emissions noted, or would be lesser, with “ N/A ” remark, if no specific emissions from the EUT are recorded (ie: margin>20dB from the applicable limit) and considered that's already beyond the background noise floor.
6. Margin (dB) = Remark result (dBuV/m) – Average limit (dBuV/m).

**Operation Mode:** TX/ IEEE 802.11n/CH Low

**Test Date:** 2012-06-13

**Temperature:** 20°C

**Humidity:** 70 % RH

Freq. (MHz)	Ant. Pol H/V	Peak Reading dBuV	AV Reading dBuV	Ant. / CL CF dB)	Actual Fs		Peak Limit dBuV/m	AV Limit dBuV/m	AV Margin dB
					Peak dBuV/m	AV dBuV/m			
4824.5	V	44.80	23.52	23.05	67.85	46.57	74.00	54.00	-7.43
N/A	V								
4824.5	H	44.48	22.24	23.05	67.53	45.29	74.00	54.00	-8.71
N/A	H								

**Notes:**

1. Measuring frequencies from 1 GHz to the 10th harmonic of highest fundamental frequency.
2. Radiated emissions measured in frequency above 1000MHz were made with an instrument using peak/average detector mode.
3. Average test would be performed if the peak result were greater than the average limit or as required by the applicant.
4. Data of measurement within this frequency range shown “ --- ” in the table above means the reading of emissions are attenuated more than 20dB below the permissible limits or the field strength is too small to be measured.
5. Measurements above show only up to 6 maximum emissions noted, or would be lesser, with “ N/A ” remark, if no specific emissions from the EUT are recorded (ie: margin>20dB from the applicable limit) and considered that's already beyond the background noise floor.
6. Margin (dB) = Remark result (dBuV/m) – Average limit (dBuV/m).

**Operation Mode:** TX/ IEEE 802.11n/CH Mid

**Test Date:** 2012-06-13

**Temperature:** 20°C

**Humidity:** 70 % RH

Freq. (MHz)	Ant. Pol H/V	Peak Reading dBuV	AV Reading dBuV	Ant. / CL CF dB)	Actual Fs		Peak Limit dBuV/m	AV Limit dBuV/m	AV Margin dB
					Peak dBuV/m	AV dBuV/m			
4874.50	V	44.06	23.16	23.98	68.04	47.14	74.00	54.00	-6.86
N/A	V								
4874.50	H	43.85	22.49	23.98	67.83	46.47	74.00	54.00	-7.53
N/A	H								

**Notes:**

1. Measuring frequencies from 1 GHz to the 10th harmonic of highest fundamental frequency.
2. Radiated emissions measured in frequency above 1000MHz were made with an instrument using peak/average detector mode.
3. Average test would be performed if the peak result were greater than the average limit or as required by the applicant.
4. Data of measurement within this frequency range shown “ --- ” in the table above means the reading of emissions are attenuated more than 20dB below the permissible limits or the field strength is too small to be measured.
5. Measurements above show only up to 6 maximum emissions noted, or would be lesser, with “ N/A ” remark, if no specific emissions from the EUT are recorded (ie: margin>20dB from the applicable limit) and considered that's already beyond the background noise floor.
6. Margin (dB) = Remark result (dBuV/m) – Average limit (dBuV/m).

**Operation Mode:** TX/ IEEE 802.11n/CH High

**Test Date:** 2012-06-13

**Temperature:** 20°C

**Humidity:** 70 % RH

Freq. (MHz)	Ant. Pol H/V	Peak Reading dBuV	AV Reading dBuV	Ant. / CL CF dB)	Actual Fs		Peak Limit dBuV/m	AV Limit dBuV/m	AV Margin dB
					Peak dBuV/m	AV dBuV/m			
4924.50	V	43.23	24.47	24.86	68.09	49.33	74.00	54.00	-4.67
N/A	V								
4924.50	H	42.63	22.32	24.86	67.49	47.18	74.00	54.00	-6.82
N/A	H								

**Notes:**

1. Measuring frequencies from 1 GHz to the 10th harmonic of highest fundamental frequency.
2. Radiated emissions measured in frequency above 1000MHz were made with an instrument using peak/average detector mode.
3. Average test would be performed if the peak result were greater than the average limit or as required by the applicant.
4. Data of measurement within this frequency range shown “ --- ” in the table above means the reading of emissions are attenuated more than 20dB below the permissible limits or the field strength is too small to be measured.
5. Measurements above show only up to 6 maximum emissions noted, or would be lesser, with “ N/A ” remark, if no specific emissions from the EUT are recorded (ie: margin>20dB from the applicable limit) and considered that's already beyond the background noise floor.
6. Margin (dB) = Remark result (dBuV/m) – Average limit (dBuV/m).

**Test Range of "2.31GHz to 2.5GHz"**

802.11b Test Mode

Frequency (MHz)	Measured Level (dBuV)	Limit (dBuV)	Margin (dB)	Height (cm)	Azimuth (deg)	Polarization	Detector
2390.00	47.93	74.00	26.07	200.00	342.00	Vertical	Peak
	38.99	54.00	15.01	100.00	240.00	Horizontal	Average
2483.50	60.22	74.00	13.78	100.00	153.00	Vertical	Peak
	39.34	54.00	14.66	100.00	220.00	Horizontal	Average

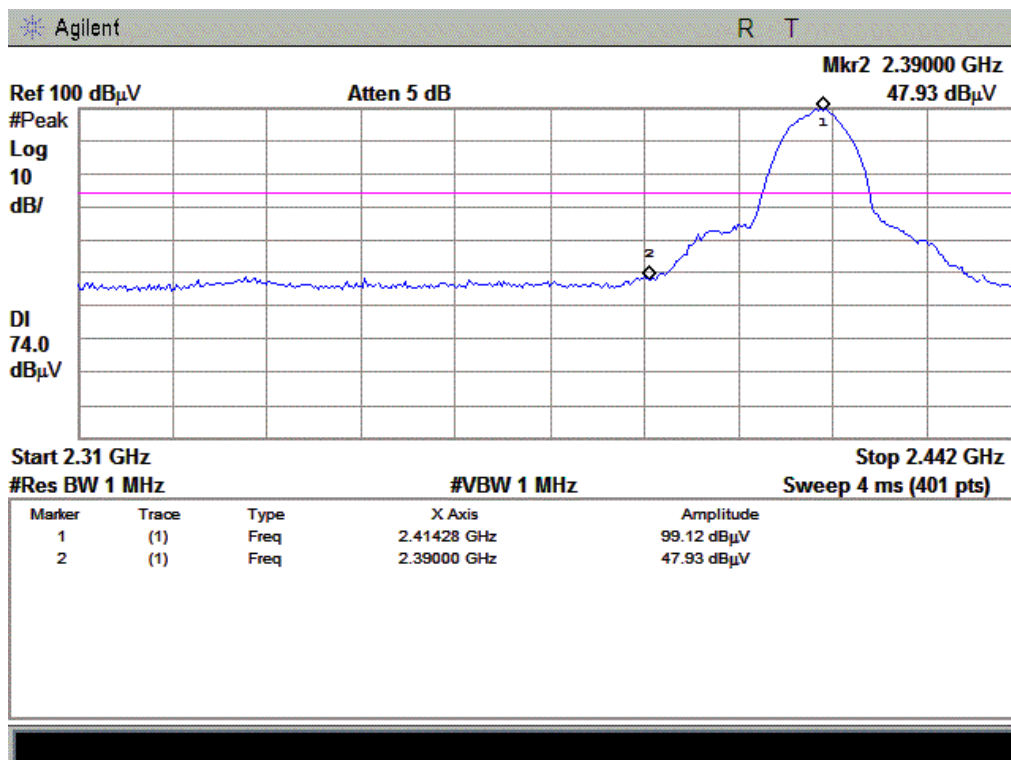

(CH Low, Peak)

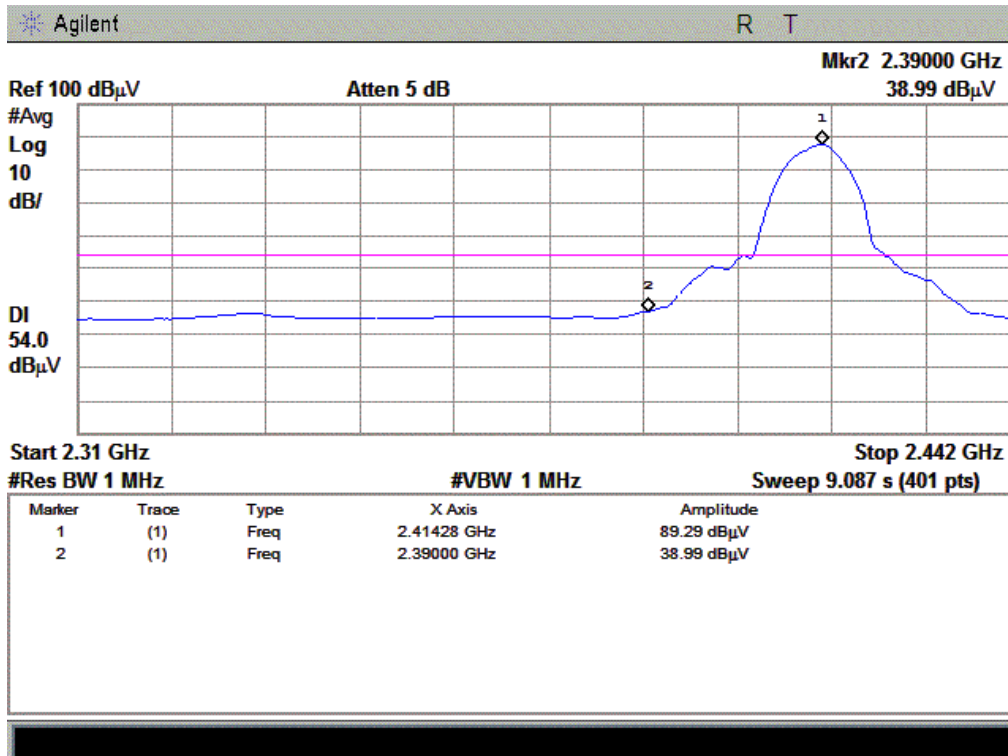

(CH Low, Average)

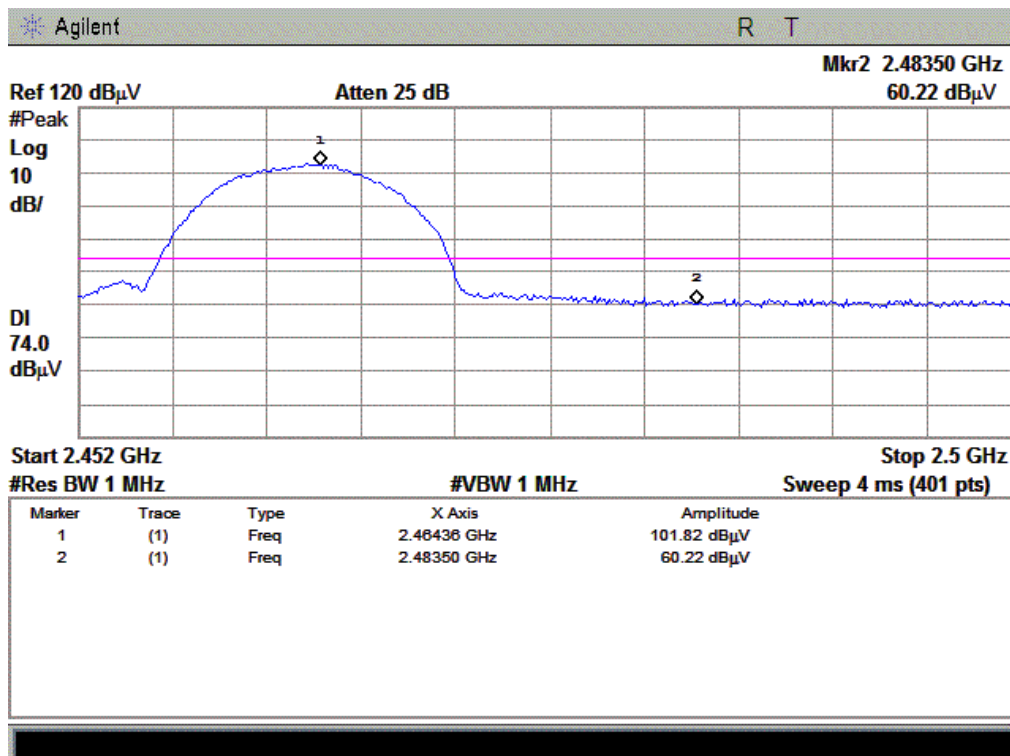

(CH High, Peak)

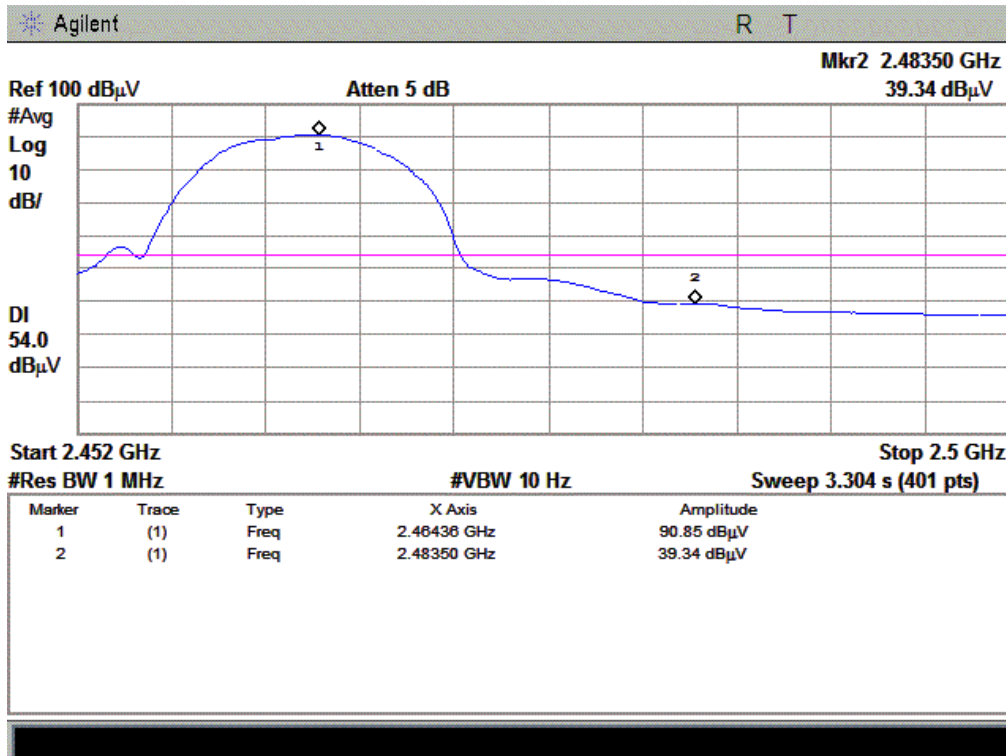

(CH High, Average)

802.11g Test Mode

Frequency (MHz)	Measured Level (dBuV)	Limit (dBuV)	Margin (dB)	Height (cm)	Azimuth (deg)	Polarization	Detector
2390.00	54.38	74.00	19.62	100.00	225.00	Vertical	Peak
	38.55	54.00	15.45	100.00	174.00	Vertical	Average
2483.50	57.34	74.00	16.66	200.00	354.00	Horizontal	Peak
	39.83	54.00	14.17	100.00	120.00	Horizontal	Average

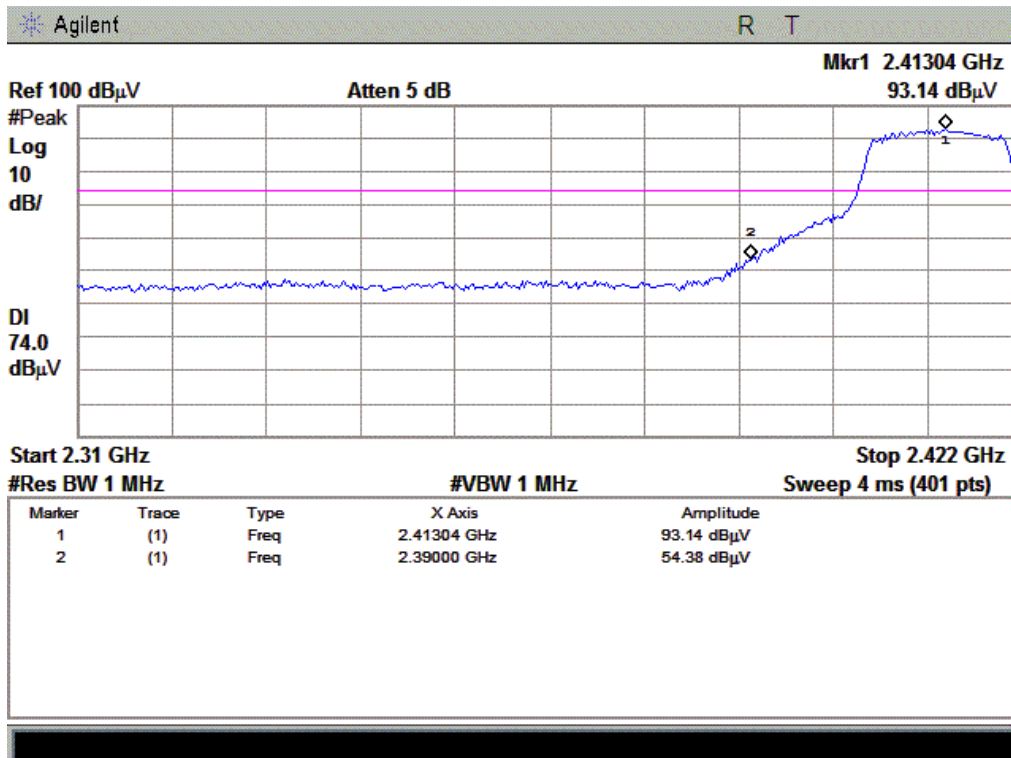

(CH Low, Peak)

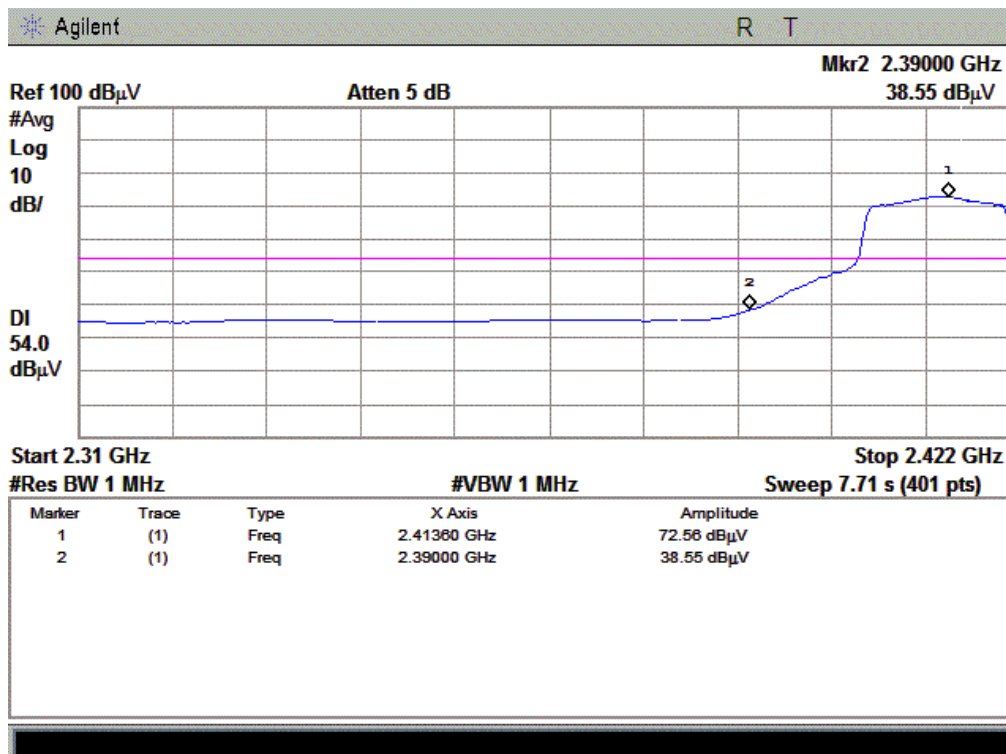

(CH Low, Average)



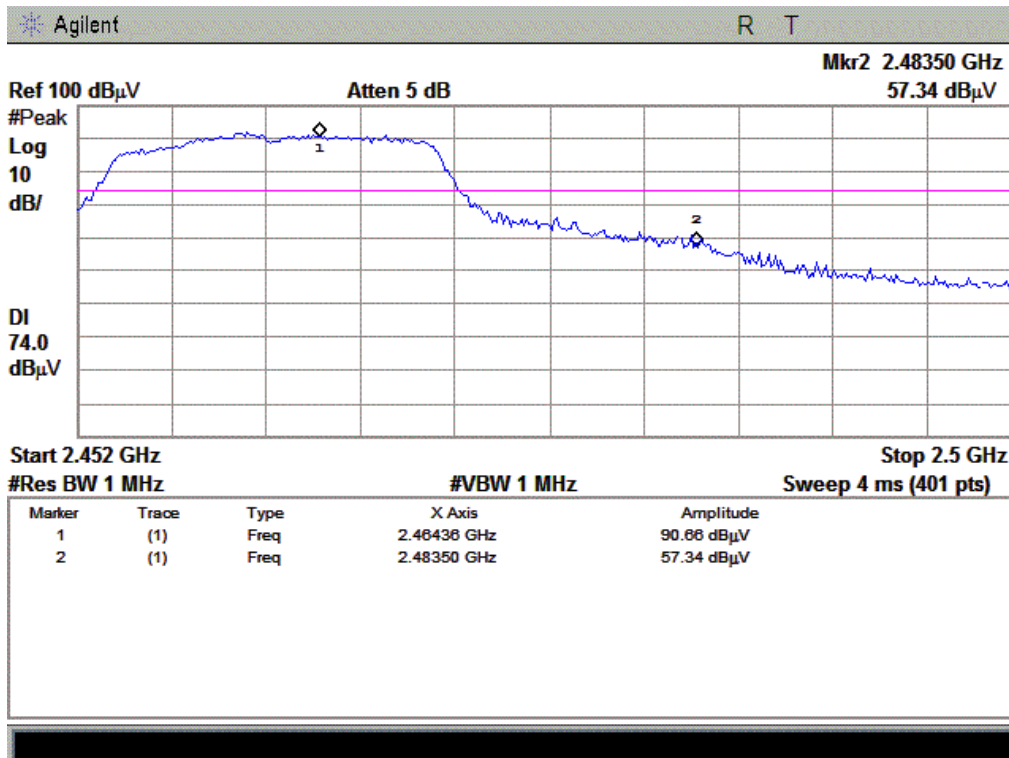

(CH High, Peak)

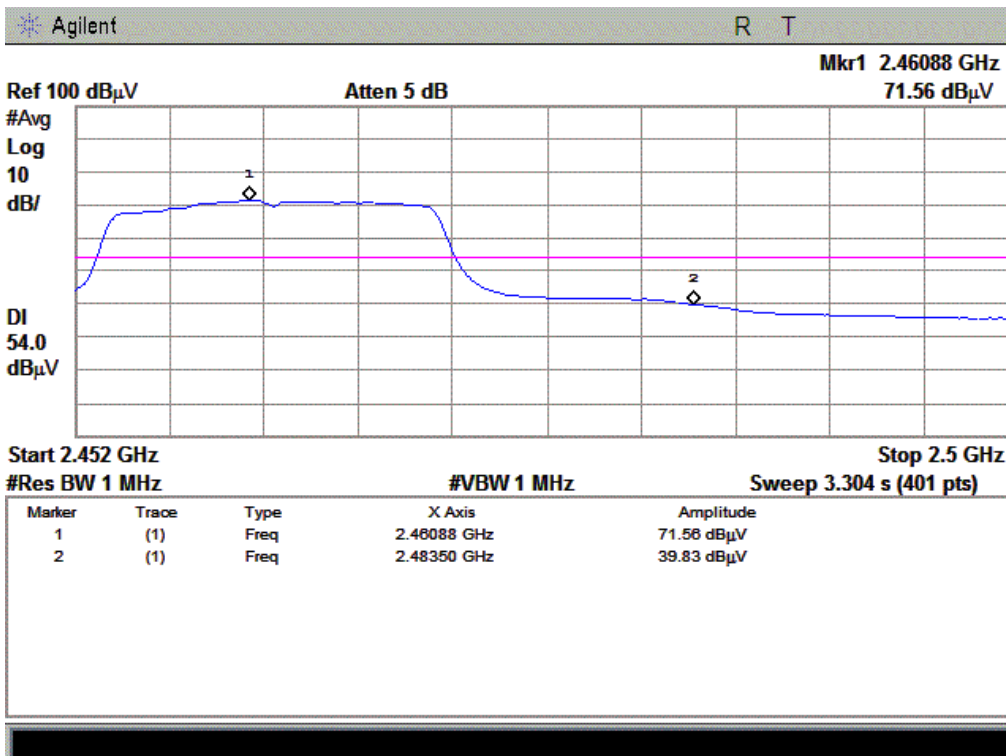

(CH High, Average)

802.11n-40MHz Test Mode

Frequency (MHz)	Measured Level (dBuV)	Limit (dBuV)	Margin (dB)	Height (cm)	Azimuth (deg)	Polarization	Detector
2390.00	55.96	74.00	18.04	100.00	268.00	Vertical	Peak
	42.55	54.00	11.45	200.00	245.00	Horizontal	Average
2483.50	62.53	74.00	11.47	200.00	249.00	Vertical	Peak
	40.82	54.00	13.18	100.00	255.00	Horizontal	Average

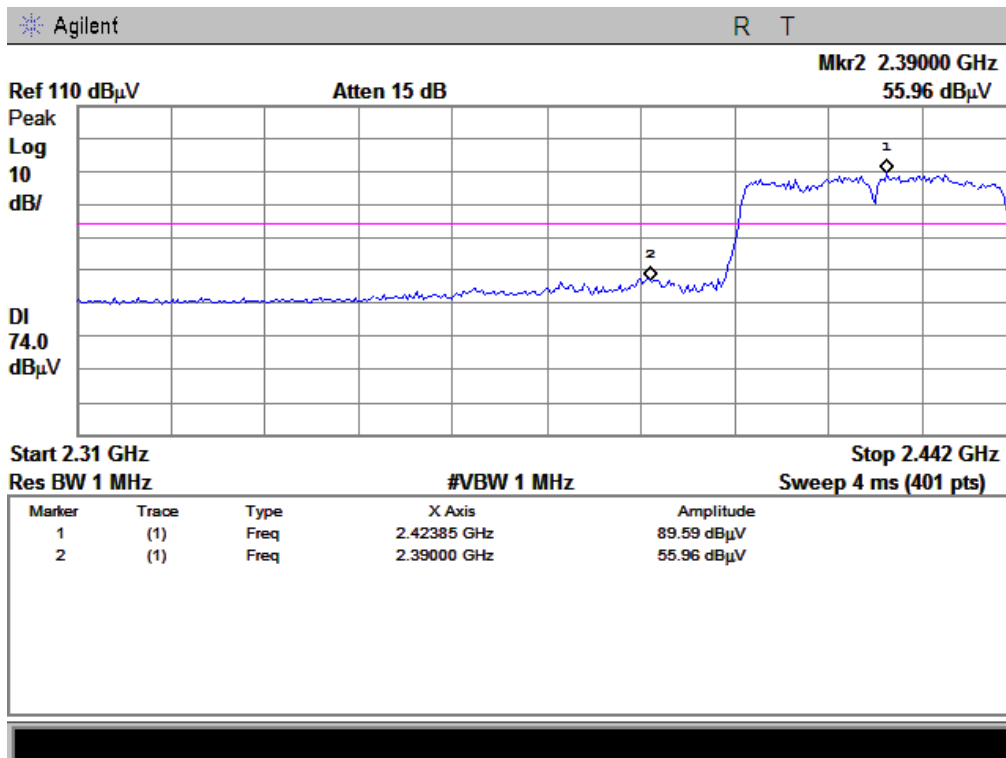

(CH Low, Peak)

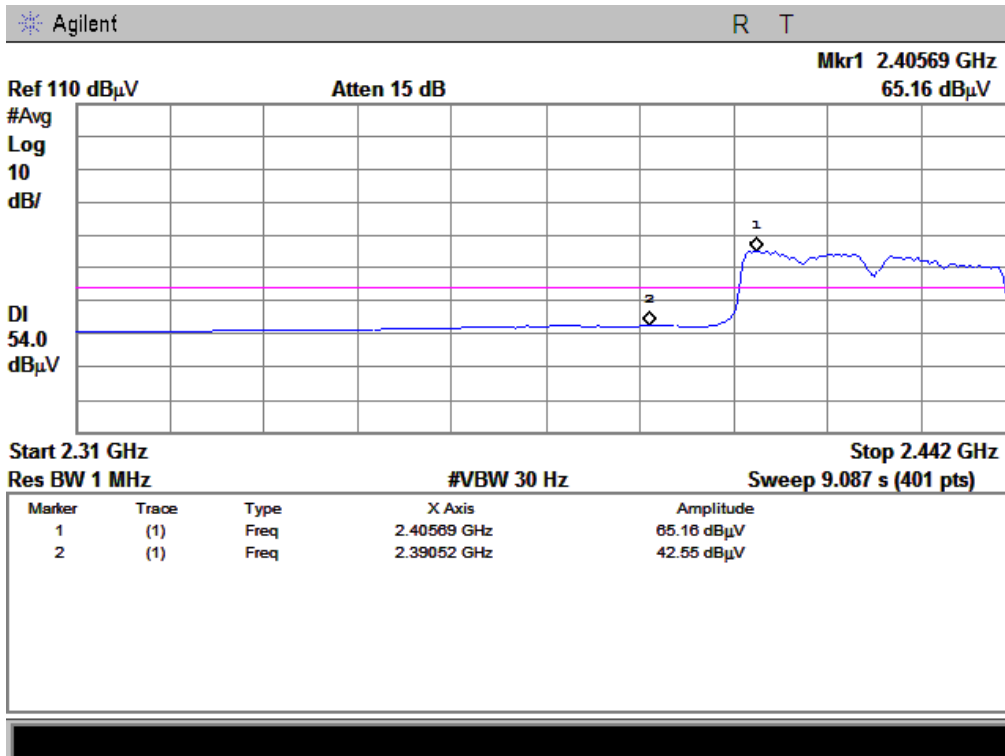

(CH Low, Average)

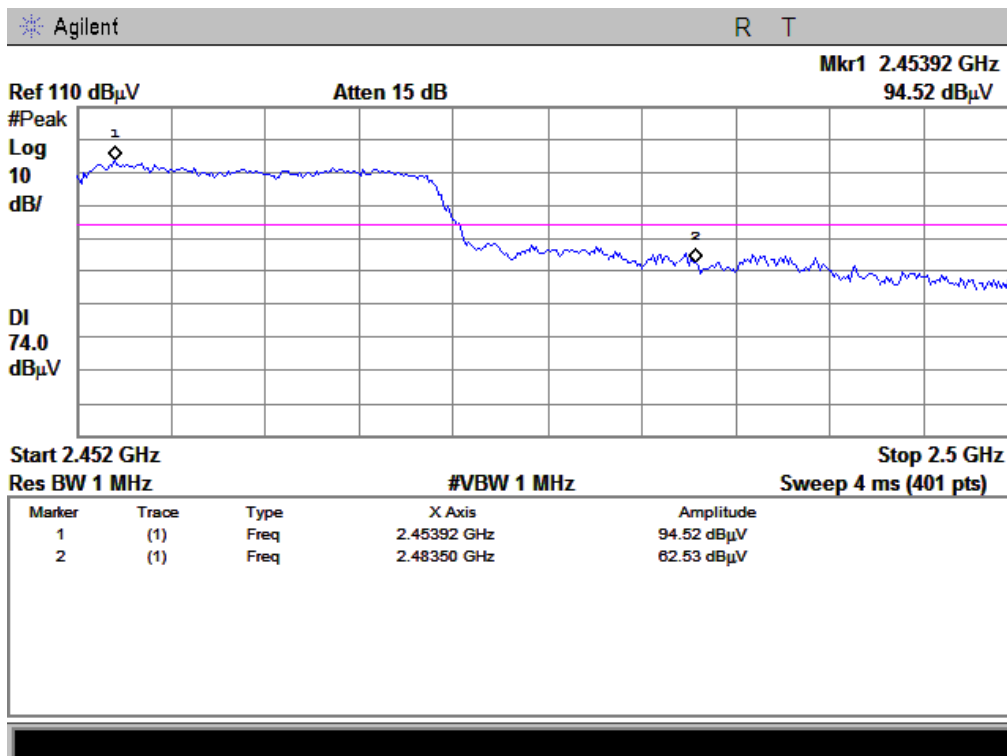

(CH High, Peak)

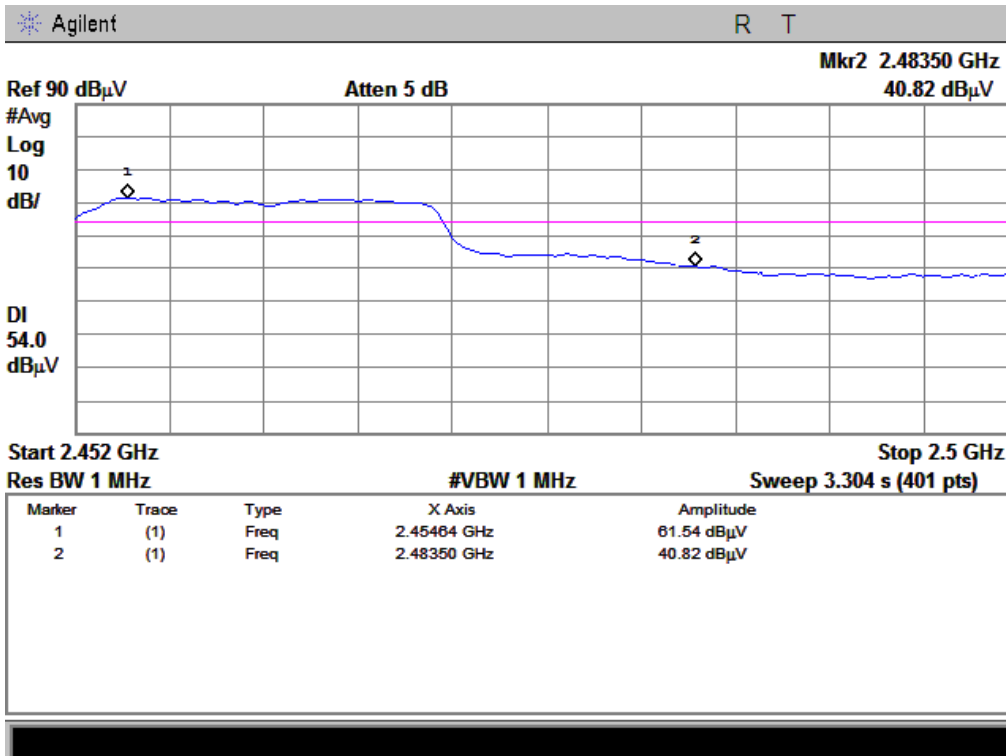

(CH High, Average)

**APPENDIX 1**  
**PHOTOGRAPHS OF TEST SETUP**

CE TEST SETUP

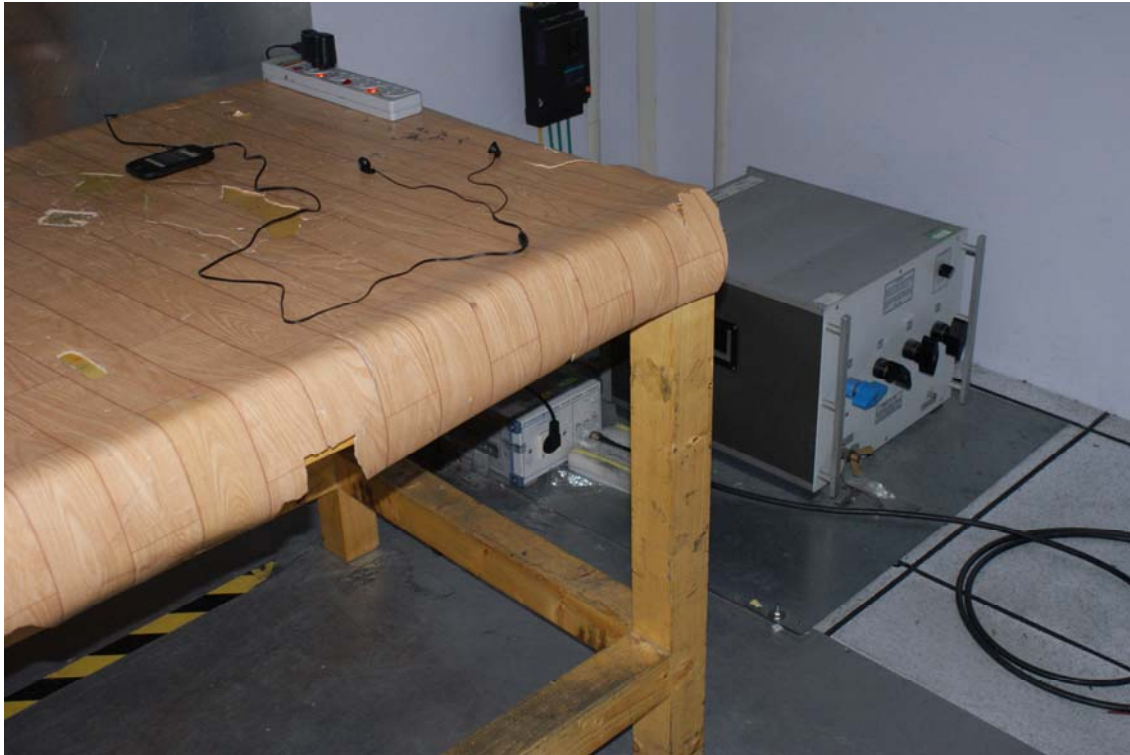

RE TEST SETUP







CONDUCTED TEST SETUP

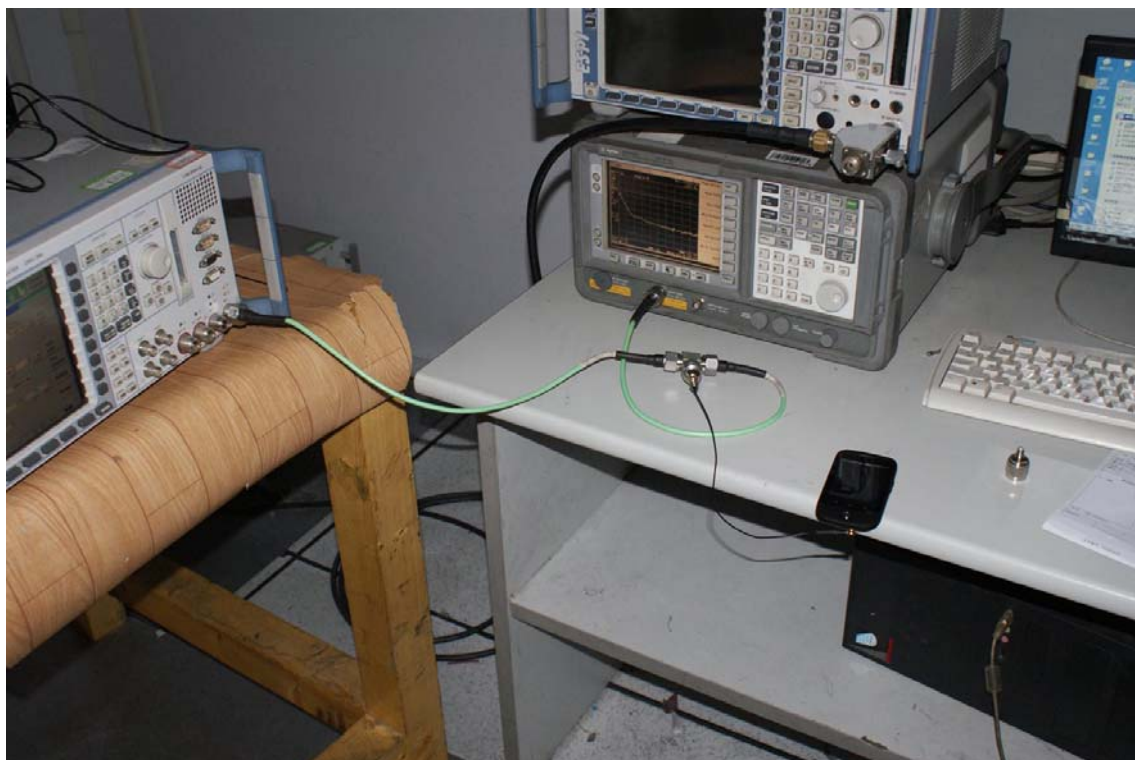

**APPENDIX 2**  
**PHOTOGRAPHS OF EUT**



FRONT VIEW OF SAMPLE



BACK VIEW OF SAMPLE



LEFT VIEW OF SAMPLE



RIGHT VIEW OF SAMPLE



UP VIEW OF SAMPLE



DOWN VIEW OF SAMPLE



PHOTO OF HEADPHONE



PHOTO OF ADAPTER



PHOTO OF BATTERY



INTERNAL PHOTO OF SAMPLE - 1



INTERNAL PHOTO OF SAMPLE -2



INTERNAL PHOTO OF SAMPLE - 3





INTERNAL PHOTO OF SAMPLE - 4



INTERNAL PHOTO OF SAMPLE - 5

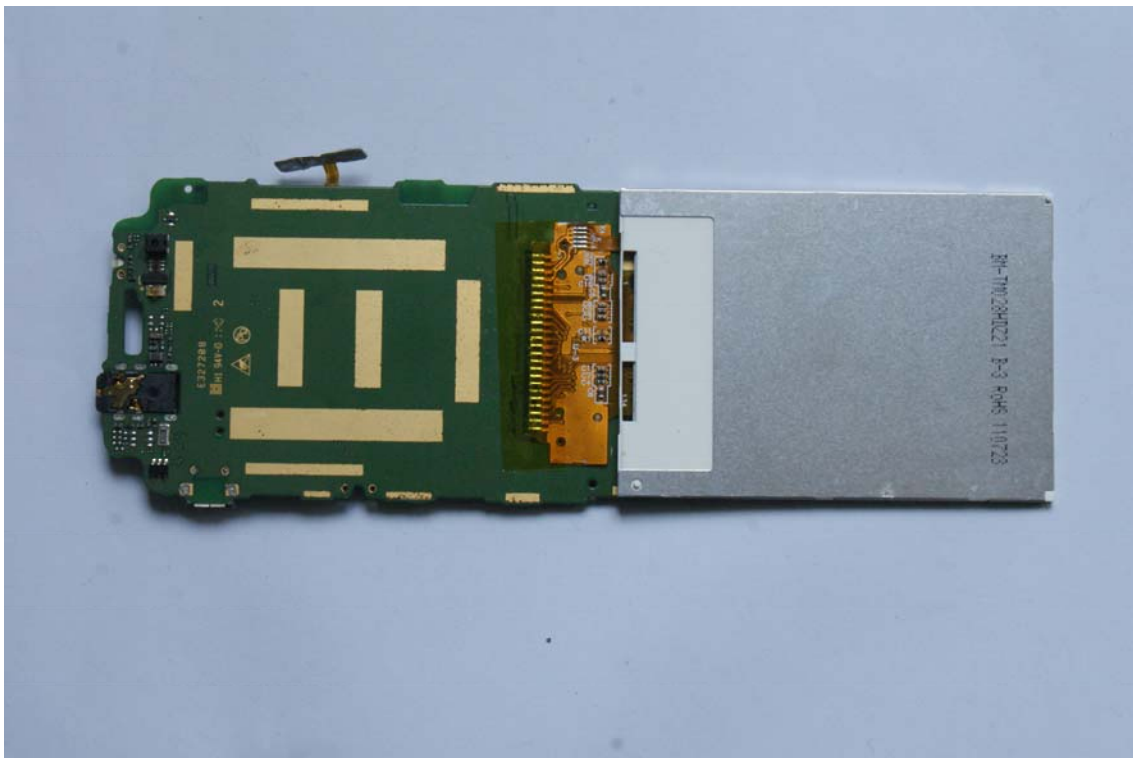

INTERNAL PHOTO OF SAMPLE - 6



INTERNAL PHOTO OF ADAPTER - 1

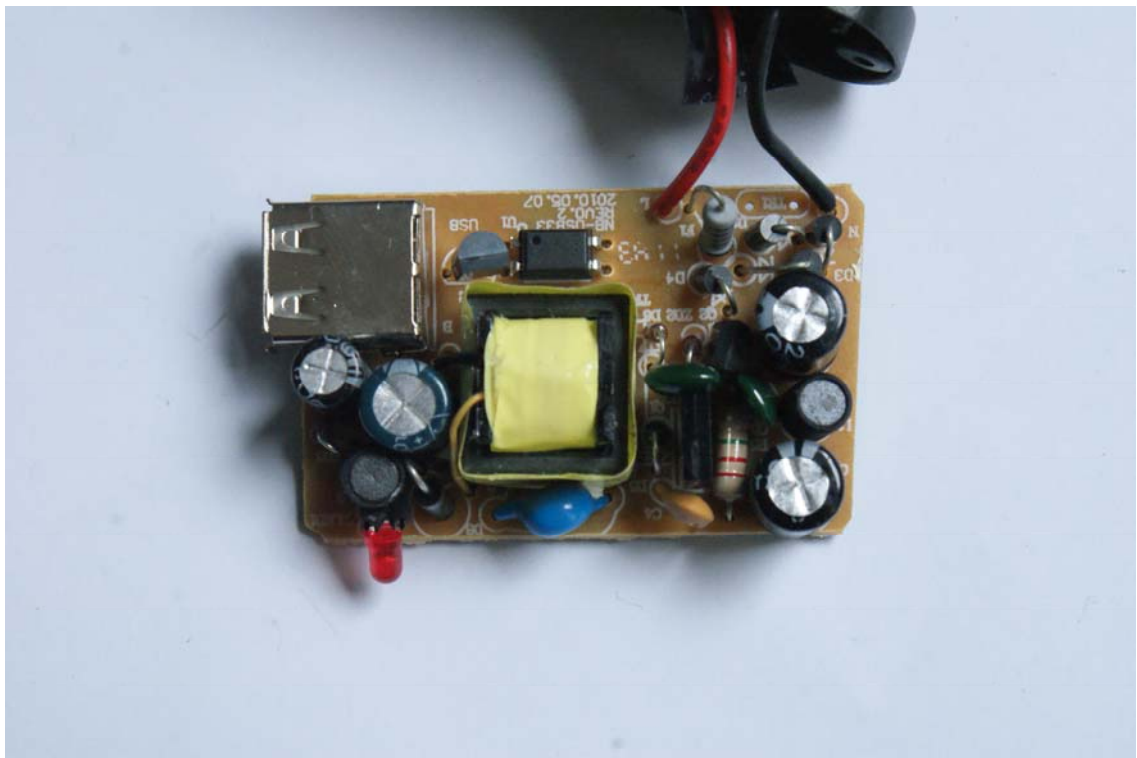



INTERNAL PHOTO OF ADAPTER - 2

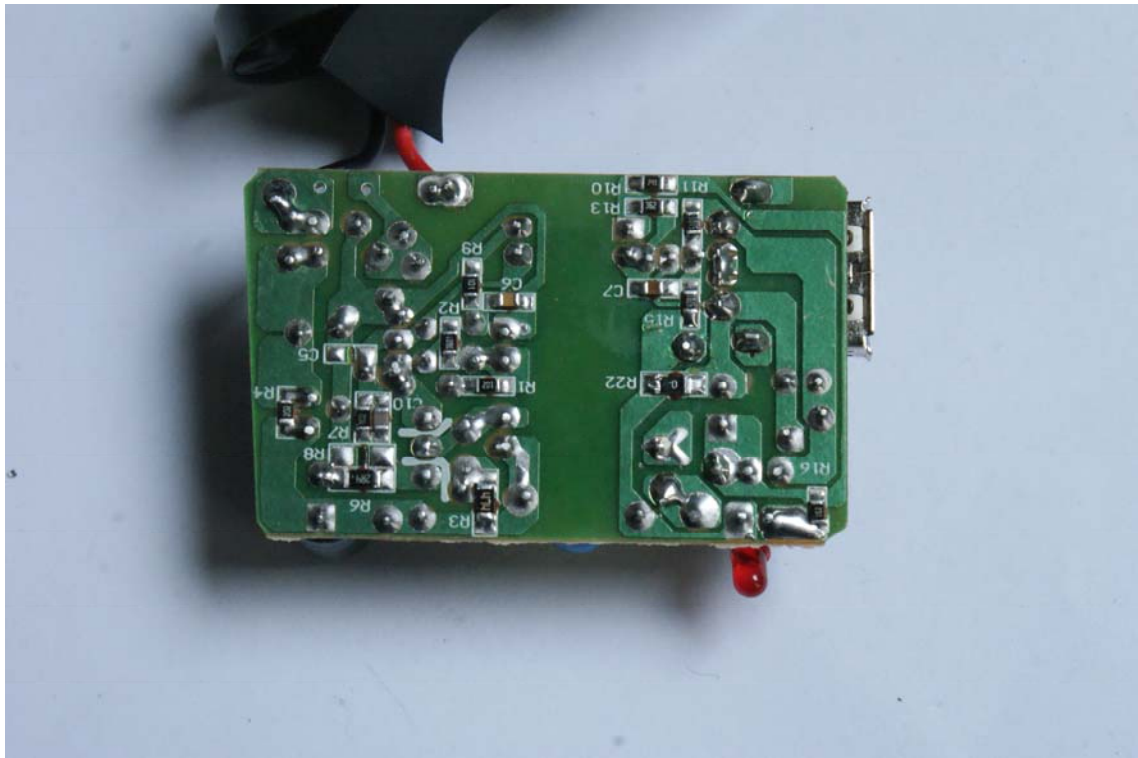

-----END OF REPORT-----