



FCC 47 CFR PART 15 SUBPART C

TEST REPORT

For

Applicant: verykool USA INC.

Address: 4350 Executive Dr. #100, San Diego, CA 92121

Product Name: GSM Mobile Phone

Model Name: S728

Brand Name: verykool

FCC ID: WA6S728

Report No.: DPH120608F05

Date of Issue: June. 28, 2012

Issued by: Super Test Service Technology Co., Ltd.

**Address: Room 506, Hongyu Commercial Building, Gushu 2nd Road,
Baoan District, Shenzhen, China**

Tel: 0755-61196328

Fax: 0755-61196328

The report consists 54 pages in total. It may be duplicated completely for legal use with the approval of the applicant. It should not be reproduced except in full, without the written approval of our laboratory. The client should not use it to claim product endorsement by STS. The test results in the report only apply to the tested sample. The test report shall be invalid without all the signatures of testing engineers, reviewer and approver.

TABLE OF CONTENTS

1. VERIFICATION OF CONFORMITY 3

2. GENERAL INFORMATION 4

2.1 PRODUCT INFORMATION 4

2.2 OBJECTIVE 5

2.3 TEST STANDARDS AND RESULTS 5

2.4 ENVIRONMENTAL CONDITIONS 5

3. TEST FACILITY 6

3.1 TEST FACILITY 6

3.2 GENERAL TEST PROCEDURES 6

3.3 FCC PART 15.205 RESTRICTED BANDS OF OPERATIONS 7

4. SETUP OF EQUIPMENT UNDER TEST 8

4.1 SUPPORT EQUIPMENT 8

4.2 TEST EQUIPMENT LIST 8

5. 47 CFR Part 15C 15.249 Requirements 10

5.1 SPURIOUS EMISSION TEST 10

5.2 BAND EDGE 25

5.3 LINE CONDUCTED EMISSION TEST 32

5.4 20dB BANDWIDTH 36

APPENDIX 1 42

PHOTOGRAPHS OF TEST SETUP 42

APPENDIX 2 45

PHOTOGRAPHS OF EUT 45

Revision History		
Issue	Date	Reason for Revision
1.0	June 28, 2012	First edition

1. VERIFICATION OF CONFORMITY

Equipment Under Test:	GSM Mobile Phone
Brand Name:	verykool
Model Number:	S728
Series Model Name:	N/A
Difference description:	N/A
FCC ID:	WA6S728
Applicant:	verykool USA INC. 4350 Executive Dr. #100, San Diego, CA 92121
Manufacturer:	Shenzhen Ginwave Technologies Ltd. 4/F, R2-A, High-Tech Industrial Park, Shenzhen 518057, China
Technical Standards:	47 CFR Part 15 Subpart C
File Number:	DPH120608F05
Date of test:	June 11 ~ June 28, 2012
Deviation:	None
Condition of Test Sample:	Normal
Test Result:	PASS

The above equipment was tested by STS for compliance with the requirements set forth in FCC rules and the Technical Standards mentioned above. This said equipment in the configuration described in this report shows the maximum emission levels emanating from equipment and the level of the immunity endurance of the equipment are within the compliance requirements.

The test results of this report relate only to the tested sample identified in this report.

Tested by (+ signature):

Approved by (+ signature):

Rex Luo

Joe Jia

Rex Luo
Test Engineer

Joe Jia
Manager

2. GENERAL INFORMATION

2.1 PRODUCT INFORMATION

Product	GSM Mobile Phone
Trade Name	verykool
Model Number	S728
Power Supply	DC 5V by AC/DC adapter 100-240V~50/60Hz DC 3.7V by battery
Frequency Range	2402MHz -2480MHz
Modulation Type	FHSS
Transmit Data Rate:	GFSK(1Mbps), $\pi/4$ -DQPSK(2Mbps), 8-DPSK(3Mbps)
Antenna Type:	Internal Fixed
Channel Spacing:	1MHz
Channel Number	79(CH Low: 2402MHz, CH Mid: 2441MHz, CH High: 2480MHz)
Temperature Range	-20°C ~ 50°C

NOTE:

1. Please refer to Appendix I for the photographs of the EUT. For a more detailed features description about the EUT, please refer to User's Manual.

2.2 OBJECTIVE

The objective of the report is to perform tests according to 47 CFR Part 15 Subpart C for the EUT FCC ID Certification:

No.	Identity	Document Title
1	47 CFR Part 15(10-1-09 Edition)	Radio Frequency Devices

2.3 TEST STANDARDS AND RESULTS

Test items and the results are as bellow:

No.	Section	Description	Result	Date of Test
1	15.249(a)	Spurious Emission	PASS	2012-06-13
2	15.249(a)	Band Edge	PASS	2012-06-13
3	15.207	Power Line Conducted Emission Test	PASS	2012-06-13

Note:

1. The test result judgment is decided by the limit of measurement standard
2. The information of measurement uncertainty is available upon the customer's request.

2.4 ENVIRONMENTAL CONDITIONS

During the measurement the environmental conditions were within the listed ranges:

- Temperature: 15-35°C
- Humidity: 30-60 %
- Atmospheric pressure: 86-106 kPa

3. TEST FACILITY

3.1 TEST FACILITY

Test Site:	Most Technology Service Co.,ltd
Location:	No.5, Langshan 2nd Rd., North Hi-Tech Industrial park, Nanshan, Shenzhen, Guangdong ,China
Description:	<p>There is one 3m semi-anechoic an area test sites and two line conducted labs for final test. The Open Area Test Sites and the Line Conducted labs are constructed and calibrated to meet the FCC requirements in documents ANSI C63.4:2009 and CISPR 16 requirements.</p> <p>The FCC Registration Number is 490827.</p> <p>The IC Registration Number is 46405-7103.</p> <p>The CNAS Registration Number is CNAS L3573.</p>
Site Filing:	The site description is on file with the Federal Communications Commission, 7435 Oakland Mills Road, Columbia, MD 21046.
Instrument Tolerance:	All measuring equipment is in accord with ANSI C63.4:2009 and CISPR 16 requirements that meet industry regulatory agency and accreditation agency requirement.
Ground Plane:	Two conductive reference ground planes were used during the Line Conducted Emission, one in vertical and the other in horizontal. The dimensions of these ground planes are as below. The vertical ground plane was placed distancing 40 cm to the rear of the wooden test table on where the EUT and the support equipment were placed during test. The horizontal ground plane projected 50 cm beyond the footprint of the EUT system and distanced 80 cm to the wooden test table. For Radiated Emission Test, one horizontal conductive ground plane extended at least 1m beyond the periphery of the EUT and the largest measuring antenna, and covered the entire area between the EUT and the antenna.

3.2 GENERAL TEST PROCEDURES

EUT Function and Test Mode

The EUT has been tested under normal operating (TX) and standby (RX) condition.

Based on client request, all normal using modes of the normal function were tested but only the worst test data of the worst mode is reported by this report.

Conducted Emissions

The EUT is placed on the turntable, which is 0.8 m above ground plane. According to the requirements in Section 13.1.4.1 of ANSI C63.4:2009,Conducted emissions from the EUT measured in the frequency range between 0.15 MHz and 30MHz using CISPR Quasi-peak and average detector modes.

Radiated Emissions

The EUT is placed on a turn table, which is 0.8 m above ground plane. The turntable shall rotate 360 degrees to determine the position of maximum emission level. EUT is set 3m away from the receiving antenna, which varied from 1m to 4m to find out the highest emission. And also, each emission was to be maximized by changing the polarization of receiving antenna both horizontal and vertical. In order to find out the maximum emissions, exploratory radiated emission measurements were made according to the requirements in Section 13.1.4.1 of ANSI C63.4:2009.

3.3 FCC PART 15.205 RESTRICTED BANDS OF OPERATIONS

(a) Except as shown in paragraph (d) of this section, only spurious emissions are permitted in any of the frequency bands listed below:

MHz	MHz	MHz	GHz
0.090 - 0.110	16.42 - 16.423	399.9 - 410	4.5 - 5.15
¹ 0.495 - 0.505	16.69475 - 16.69525	608 - 614	5.35 - 5.46
2.1735 - 2.1905	16.80425 - 16.80475	960 - 1240	7.25 - 7.75
4.125 - 4.128	25.5 - 25.67	1300 - 1427	8.025 - 8.5
4.17725 - 4.17775	37.5 - 38.25	1435 - 1626.5	9.0 - 9.2
4.20725 - 4.20775	73 - 74.6	1645.5 - 1646.5	9.3 - 9.5
6.215 - 6.218	74.8 - 75.2	1660 - 1710	10.6 - 12.7
6.26775 - 6.26825	108 - 121.94	1718.8 - 1722.2	13.25 - 13.4
6.31175 - 6.31225	123 - 138	2200 - 2300	14.47 - 14.5
8.291 - 8.294	149.9 - 150.05	2310 - 2390	15.35 - 16.2
8.362 - 8.366	156.52475 - 156.52525	2483.5 - 2500	17.7 - 21.4
8.37625 - 8.38675	156.7 - 156.9	2655 - 2900	22.01 - 23.12
8.41425 - 8.41475	162.0125 - 167.17	3260 - 3267	23.6 - 24.0
12.29 - 12.293	167.72 - 173.2	3332 - 3339	31.2 - 31.8
12.51975 - 12.52025	240 - 285	3345.8 - 3358	36.43 - 36.5
12.57675 - 12.57725	322 - 335.4	3600 - 4400	(²)
13.36 - 13.41			

¹ Until February 1, 1999, this restricted band shall be 0.490-0.510 MHz.

² Above 38.6

(b) Except as provided in paragraphs (d) and (e), the field strength of emissions appearing within these frequency bands shall not exceed the limits shown in Section 15.209. At frequencies equal to or less than 1000 MHz, compliance with the limits in Section 15.209 shall be demonstrated using measurement instrumentation employing a CISPR quasi-peak detector. Above 1000 MHz, compliance with the emission limits in Section 15.209 shall be demonstrated based on the average value of the measured emissions. The provisions in Section 15.35 apply to these measurements.

4. SETUP OF EQUIPMENT UNDER TEST

4.1 SUPPORT EQUIPMENT

Device Type	Brand	Model	Series No.	Data Cable	Power Cord
N/A	N/A	N/A	N/A	N/A	N/A

Remark:

All the equipment/cables were placed in the worst-case configuration to maximize the emission during the test. Grounding was established in accordance with the manufacturer's requirements and conditions for the intended use.

4.2 TEST EQUIPMENT LIST

Instrumentation: The following list contains equipment used at Most for testing. The equipment conforms to the CISPR 16-1 / ANSI C63.2 Specifications for Electromagnetic Interference and Field Strength Instrumentation from 10 kHz to 1.0 GHz or above.

No.	Equipment	Manufacturer	Model No.	S/N	Calibration due date
1	Test Receiver	Rohde & Schwarz	ESCI	100492	2013/4/21
2	L.I.S.N.	Rohde & Schwarz	ENV216	100093	2013/4/21
3	Coaxial Switch	Anritsu Corp	MP59B	6200283933	2013/3/14
4	Terminator	Hubersuhner	50Ω	No.1	2013/3/14
5	RF Cable	SchwarzBeck	N/A	No.1	N/A
6	Test Receiver	Rohde & Schwarz	ESPI	101202	2013/4/21
7	Test Antenna – Horn	Schwarzbeck	BBHA 9120C	--	2013/3/14
8	Test Antenna – Bi-Log	Schwarzbeck	VULB 9163	--	2013/3/14
9	Power Splitter	Weinschel	1506A	NW521	N/A
10	Spectrum Analyzer	Agilent	4408B	MY41440460	2013/4/21
11	Cable	Resenberger	N/A	NO.1	N/A
12	Cable	SchwarzBeck	N/A	NO.2	N/A

13	Cable	SchwarzBeck	N/A	NO.3	N/A
14	Signal Generator	IFR	2032	203002/100	2013/5421
15	Universal Radio Communication Tester	ROHDE&SCHWARZ	CMU200	0304789	2013/4/21
16	Telecommunication Antenna	European Antennas	PSA 75301R/170	0304213	2012/03/14
17	DC Power Supply	Good Will	GPS-3030DD	EF920938	2013/4/21
18	Full-Anechoic Chamber	Albatross	9m*6m*6m	(n.a.)	2013/4/15

NOTE: Equipments listed above have been calibrated and are in the period of validation.

5. 47 CFR PART 15C 15.249 REQUIREMENTS
5.1 SPURIOUS EMISSION TEST
5.1.1 REQUIREMENT

According to FCC section 15.249(a):

Except as provided in paragraph (a) of this section, the field strength of emissions from intentional radiators operated within these frequency bands shall comply with the following:

Fundamental Frequency (MHz)	Field Strength of Fundamental (mV/m)	Field Strength of Harmonics (µV/m)
902-928	50	500
2400-2483.5	50	500
5725-5875	50	500
24000-24250	250	2500

According to FCC section 15.209 (a), except as provided elsewhere in this subpart, the emissions from an intentional radiator shall not exceed the field strength levels specified in the following table:

Frequency (MHz)	Field Strength (µV/m)	Measurement Distance (m)
1.705 - 30.0	30	30
30 - 88	100	3
88 - 216	150	3
216 - 960	200	3
Above 960	500	3

Remark: Except as provided in paragraph (g), fundamental emissions from intentional radiators operating under this Section shall not be located in the frequency bands 54-72 MHz, 76-88 MHz, 174-216 MHz or 470-806 MHz. However, operation within these frequency bands is permitted under other sections of this Part, e.g., Sections 15.231 and 15.241.

In the above emission table, the tighter limit applies at the band edges.

Frequency (MHz)	Field Strength (µV/m)	Measurement Distance (m)
30 - 88	100	3
88 - 216	150	3
216 - 960	200	3
Above 960	500	3

5.1.2 TEST DESCRIPTION

TEST SETUP:

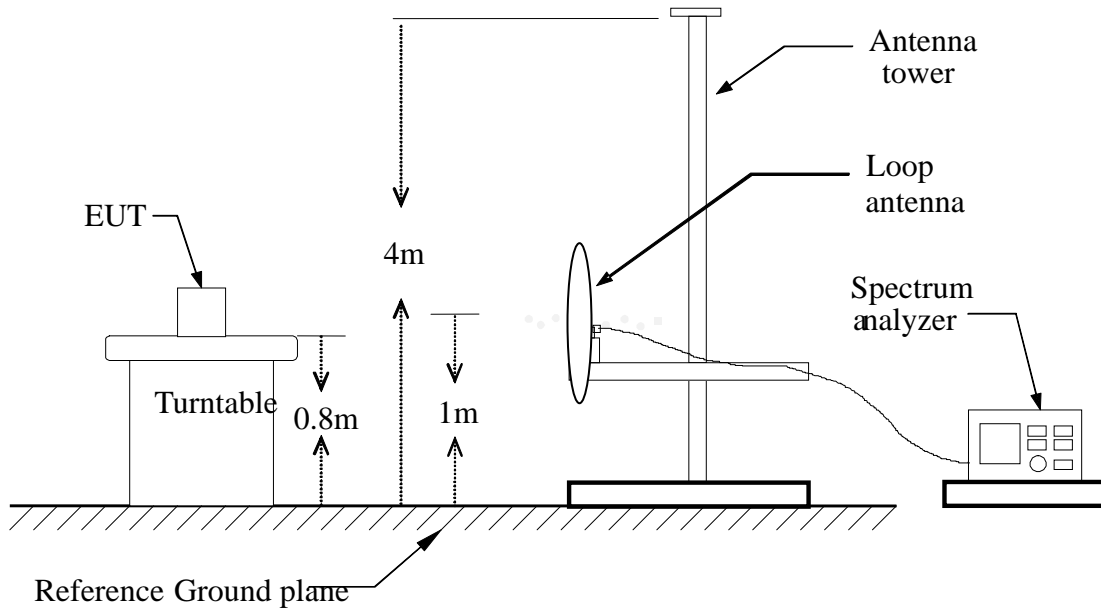

Blow 1GHz:

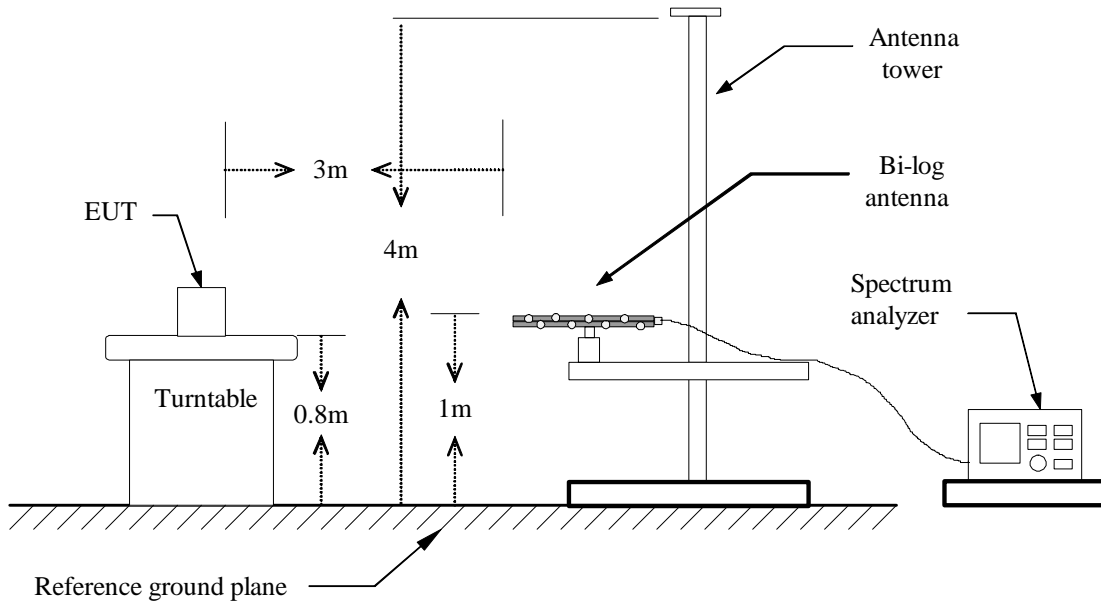

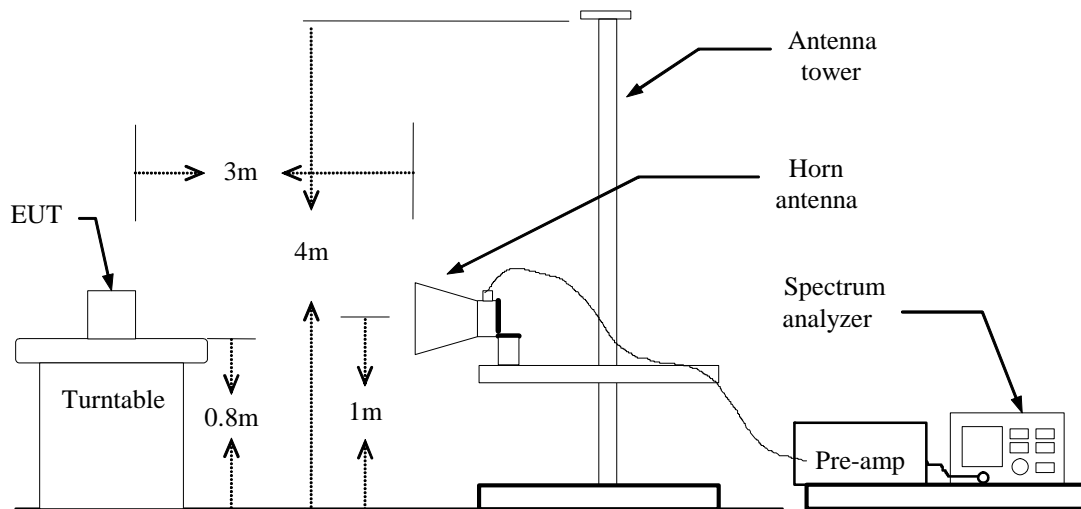
Above 1GHz:**5.1.3 TEST DESCRIPTION**

1. The EUT is placed on a turntable, which is 0.8m above ground plane.
2. The turntable shall be rotated for 360 degrees to determine the position of maximum emission level.
3. EUT is set 3m away from the receiving antenna, which is varied from 1m to 4m to find out the highest emissions.
4. Maximum procedure was performed on the six highest emissions to ensure EUT compliance.
5. And also, each emission was to be maximized by changing the polarization of receiving antenna both horizontal and vertical.
6. Set the spectrum analyzer in the following setting as:
 - Below 1GHz: RBW=100 kHz / VBW=300 kHz / Sweep=AUTO
 - Above 1GHz : (a) PEAK: RBW=VBW=1MHz / Sweep=AUTO
 - (b) AVERAGE: RBW=1MHz / VBW=1MHz / Sweep=AUTO
7. Repeat above procedures until the measurements for all frequencies are complete.

5.1.4 TEST RESULT

Form 9 KHz to 30MHz:

Freq. (MHz)	Ant. Pol H/V	Peak Reading (dBuV)	Ant. / CL CF (dB)	Actual Fs Peak (dBuV/m)	Peak Limit (dBuV/m)	Peak Margin (dB)
	H					
	H					
	H					
N/A						>20
	V					
	V					
	V					
N/A						>20

-Note: No test data was detected in below 30MHz.

Form 30 MHz to 1GHz:

Radiated Emission Measurement

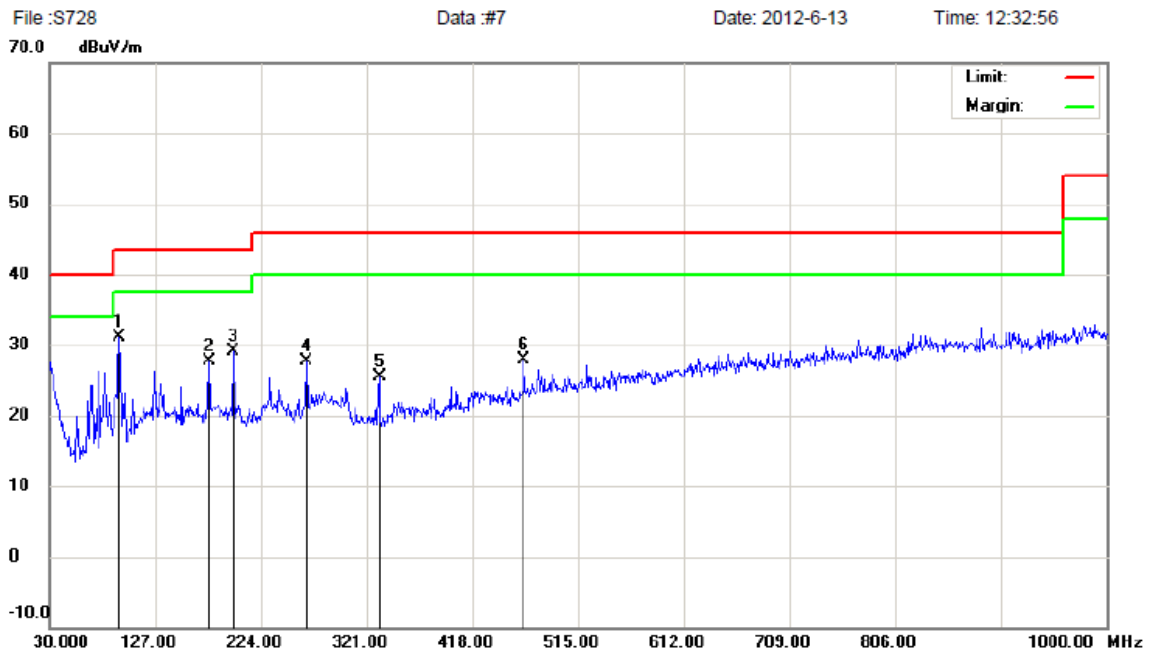

Site site MOST 3M Polarization: *Vertical* Temperature: 26
 Limit: FCC Part15 B 3M Radiation Power: AC 120V/60Hz Humidity: 60 %
 EUT: GSM MOBILE PHONE Distance:
 M/N: S728
 Mode: BLUETOOTH
 Note:

No.	Mk.	Freq. MHz	Reading Level dBuV	Correct Factor dB	Measure- ment dBuV/m	Limit dBuV/m	Over dB	Detector	Antenna Height cm	Table Degree	Comment
1	*	94.0200	19.09	11.92	31.01	43.50	-12.49	peak			
2		176.4700	10.73	16.88	27.61	43.50	-15.89	peak			
3		198.7800	11.91	17.27	29.18	43.50	-14.32	peak			
4		265.7100	9.29	18.35	27.64	46.00	-18.36	peak			
5		332.6400	8.45	17.03	25.48	46.00	-20.52	peak			
6		465.5300	6.85	20.98	27.83	46.00	-18.17	peak			

*:Maximum data x:Over limit !:over margin

Radiated Emission Measurement

File :S728 Data :#6 Date: 2012-6-13 Time: 12:29:15

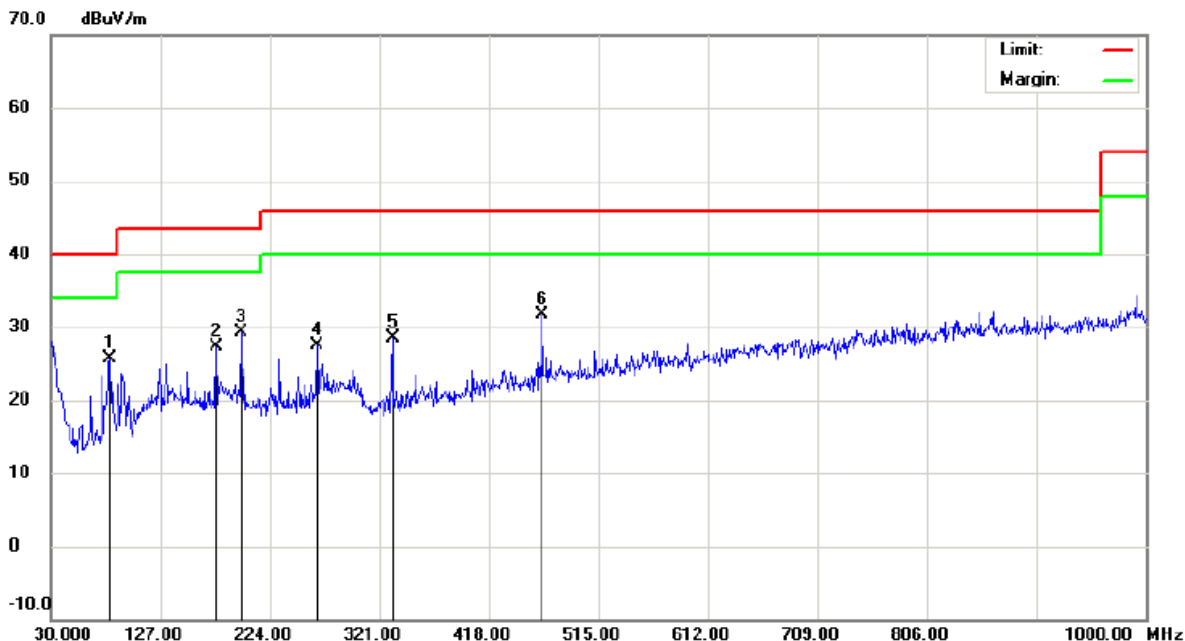

Site site MOST 3M Polarization: *Horizontal* Temperature: 26
 Limit: FCC Part15 B 3M Radiation Power: AC 120V/60Hz Humidity: 60 %
 EUT: GSM MOBILE PHONE Distance:
 M/N: S728
 Mode: BLUETOOTH
 Note:

No.	Mk.	Freq. MHz	Reading Level dBuV	Correct Factor dB	Measure- ment dBuV/m	Limit dBuV/m	Over dB	Detector	Antenna Height cm	Table Degree	Comment
1	*	82.3800	13.41	11.35	24.76	40.00	-15.24	peak			
2		176.4700	11.43	16.88	28.31	43.50	-15.19	peak			
3		198.7800	11.95	17.27	29.22	43.50	-14.28	peak			
4		265.710	10.13	18.35	28.48	46.00	-17.52	peak			
5		332.6400	12.15	17.03	29.18	46.00	-16.82	peak			
6		465.5300	10.57	20.98	31.55	46.00	-14.45	peak			

*:Maximum data x:Over limit !:over margin

Above 1 GHz

Operation Mode: GFSK Mode (Low Channel) **Test Date:** 2012-06-13
Temperature: 20°C **Humidity:** 70 % RH

Freq. (MHz)	Ant. Pol H/V	Peak Reading (dBuV)	AV Reading (dBuV)	Ant. / CL CF (dB)	Actual Fs		Peak Limit (dBuV/m)	AV Limit (dBuV/m)	AV Margin (dB)
					Peak (dBuV/m)	AV (dBuV/m)			
2402.00	H	87.48	69.59	9.08	96.56	78.67	114.00	94.00	-15.33
1612.50	H	57.34	39.73	7.02	64.36	46.75	74.00	54.00	-7.25
N/A									>20
2402.00	V	84.54	66.84	9.08	93.62	75.92	114.00	94.00	-18.08
1612.50	V	55.74	37.17	7.02	62.76	44.19	74.00	54.00	-9.81
N/A									>20

Notes:

1. Measuring frequencies from 1 GHz to the 10th harmonic of highest fundamental frequency.
2. Measurements above show only up to 6 maximum emissions noted, or would be lesser if no specific emissions from the EUT are recorded (ie: margin>20dB from the applicable limit) and considered that's already beyond the background noise floor.
3. Radiated emissions measured in frequency above 1000MHz were made with an instrument using Peak detector mode and average detector mode of the emission shown in Actual FS column.
4. Spectrum setting:
 - a. Peak Setting 1GHz - 26GHz, RBW = 1MHz, VBW = 1MHz, Sweep time = *auto*.
 - b. AV Setting 1GHz- 26GHz, RBW = 1MHz, VBW = 1MHz, Sweep time = *auto*.

Operation Mode: GFSK Mode (Mid Channel) **Test Date:** 2012-06-13
Temperature: 20°C **Humidity:** 70 % RH

Freq. (MHz)	Ant. Pol H/V	Peak	AV	Ant. / CL	Actual Fs		Peak	AV	AV
		Reading	Reading	CF	Peak (dBuV/m)	AV (dBuV/m)	Limit	Limit	Margin
		(dBuV)	(dBuV)	(dB)			(dBuV/m)	(dBuV/m)	(dB)
2441.00	H	90.21	66.54	9.31	99.52	75.85	114.00	94.00	-18.15
1630.00	H	53.35	40.63	7.25	60.60	47.88	74.00	54.00	-6.12
N/A									>20
2441.00	V	87.43	63.97	9.31	96.74	73.28	114.00	94.00	-20.72
1630.00	V	51.35	38.71	7.25	58.60	45.96	74.00	54.00	-8.04
N/A									>20

Notes:

1. Measuring frequencies from 1 GHz to the 10th harmonic of highest fundamental frequency.
2. Measurements above show only up to 6 maximum emissions noted, or would be lesser if no specific emissions from the EUT are recorded (ie: margin>20dB from the applicable limit) and considered that's already beyond the background noise floor.
3. Radiated emissions measured in frequency above 1000MHz were made with an instrument using Peak detector mode and average detector mode of the emission shown in Actual FS column.
4. Spectrum setting:
 - a. Peak Setting 1GHz - 26GHz, RBW = 1MHz, VBW = 1MHz, Sweep time = *auto*.
 - b. AV Setting 1GHz- 26GHz, RBW = 1MHz, VBW = 1MHz, Sweep time = *auto*.

Operation Mode: GFSK Mode (High Channel) **Test Date:** 2012-06-13
Temperature: 20°C **Humidity:** 70 % RH

Freq. (MHz)	Ant. Pol H/V	Peak Reading (dBuV)	AV Reading (dBuV)	Ant. / CL CF (dB)	Actual Fs		Peak Limit (dBuV/m)	AV Limit (dBuV/m)	AV Margin (dB)
					Peak	AV			
					(dBuV/m)	(dBuV/m)			
2480.00	H	87.83	62.34	9.47	97.30	71.81	114.00	94.00	-22.19
1647.50	H	52.75	39.62	7.52	60.27	47.14	74.00	54.00	-6.86
N/A									>20
2480.00	V	86.12	65.83	9.47	95.59	75.30	114.00	94.00	-18.70
1647.50	V	52.28	40.77	7.52	59.80	48.29	74.00	54.00	-5.71
N/A									>20

Notes:

1. Measuring frequencies from 1 GHz to the 10th harmonic of highest fundamental frequency.
2. Measurements above show only up to 6 maximum emissions noted, or would be lesser if no specific emissions from the EUT are recorded (ie: margin>20dB from the applicable limit) and considered that's already beyond the background noise floor.
3. Radiated emissions measured in frequency above 1000MHz were made with an instrument using Peak detector mode and average detector mode of the emission shown in Actual FS column.
4. Spectrum setting:
 - a. Peak Setting 1GHz - 26GHz, RBW = 1MHz, VBW = 1MHz, Sweep time = *auto*.
 - b. AV Setting 1GHz- 26GHz, RBW = 1MHz, VBW = 1MHz, Sweep time = *auto*.

Operation Mode: $\pi/4$ -DQPSK Mode (Low Channel) **Test Date:** 2012-06-13

Temperature: 20°C **Humidity:** 70 % RH

Freq. (MHz)	Ant. Pol H/V	Peak Reading (dBuV)	AV Reading (dBuV)	Ant. / CL CF (dB)	Actual Fs		Peak Limit (dBuV/m)	AV Limit (dBuV/m)	AV Margin (dB)
					Peak (dBuV/m)	AV (dBuV/m)			
2402.00	H	91.27	68.13	9.08	100.35	77.21	114.00	94.00	-16.79
1612.50	H	59.83	38.68	7.02	66.85	45.70	74.00	54.00	-8.30
N/A									>20
2402.00	V	88.35	67.71	9.08	97.43	76.79	114.00	94.00	-17.21
1612.50	V	57.31	38.11	7.02	64.33	45.13	74.00	54.00	-8.87
N/A									>20

Notes:

1. Measuring frequencies from 1 GHz to the 10th harmonic of highest fundamental frequency.
2. Measurements above show only up to 6 maximum emissions noted, or would be lesser if no specific emissions from the EUT are recorded (ie: margin>20dB from the applicable limit) and considered that's already beyond the background noise floor.
3. Radiated emissions measured in frequency above 1000MHz were made with an instrument using Peak detector mode and average detector mode of the emission shown in Actual FS column.
4. Spectrum setting:
 - a. Peak Setting 1GHz - 26GHz, RBW = 1MHz, VBW = 1MHz, Sweep time = *auto*.
 - b. AV Setting 1GHz- 26GHz, RBW = 1MHz, VBW = 1MHz, Sweep time = *auto*.

Operation Mode: $\pi/4$ -DQPSK Mode (Mid Channel)

Test Date: 2012-06-13

Temperature: 20°C

Humidity: 70 % RH

Freq. (MHz)	Ant. Pol H/V	Peak	AV	Ant. / CL	Actual Fs		Peak	AV	AV
		Reading (dBuV)	Reading (dBuV)	CF (dB)	Peak (dBuV/m)	AV (dBuV/m)	Limit (dBuV/m)	Limit (dBuV/m)	Margin (dB)
2441.00	H	92.54	69.37	9.31	101.85	78.68	114.00	94.00	-15.32
1630.00	H	60.64	39.54	7.25	67.89	46.79	74.00	54.00	-7.21
N/A									>20
2441.00	V	88.74	67.34	9.31	98.05	76.65	114.00	94.00	-17.35
1630.00	V	57.75	37.13	7.25	65.00	44.38	74.00	54.00	-9.62
N/A									>20

Notes:

1. Measuring frequencies from 1 GHz to the 10th harmonic of highest fundamental frequency.
2. Measurements above show only up to 6 maximum emissions noted, or would be lesser if no specific emissions from the EUT are recorded (ie: margin>20dB from the applicable limit) and considered that's already beyond the background noise floor.
3. Radiated emissions measured in frequency above 1000MHz were made with an instrument using Peak detector mode and average detector mode of the emission shown in Actual FS column.
4. Spectrum setting:
 - a. Peak Setting 1GHz - 26GHz, RBW = 1MHz, VBW = 1MHz, Sweep time = *auto*.
 - b. AV Setting 1GHz- 26GHz, RBW = 1MHz, VBW = 1MHz, Sweep time = *auto*.

Operation Mode: $\pi/4$ -DQPSK Mode (High Channel)

Test Date: 2012-06-13

Temperature: 20°C

Humidity: 70 % RH

Freq. (MHz)	Ant. Pol H/V	Peak Reading (dBuV)	AV Reading (dBuV)	Ant. / CL CF (dB)	Actual Fs		Peak Limit (dBuV/m)	AV Limit (dBuV/m)	AV Margin (dB)
					Peak (dBuV/m)	AV (dBuV/m)			
2480.00	H	88.57	67.14	9.47	98.04	76.61	114.00	94.00	-17.39
1647.50	H	58.35	40.42	7.52	65.87	47.94	74.00	54.00	-6.06
N/A									>20
2480.00	V	87.34	66.37	9.47	96.81	75.84	114.00	94.00	-18.16
1647.50	V	56.39	39.84	7.52	63.91	47.36	74.00	54.00	-6.64
N/A									>20

Notes:

1. Measuring frequencies from 1 GHz to the 10th harmonic of highest fundamental frequency.
2. Measurements above show only up to 6 maximum emissions noted, or would be lesser if no specific emissions from the EUT are recorded (ie: margin>20dB from the applicable limit) and considered that's already beyond the background noise floor.
3. Radiated emissions measured in frequency above 1000MHz were made with an instrument using Peak detector mode and average detector mode of the emission shown in Actual FS column.
4. Spectrum setting:
 - a. Peak Setting 1GHz - 26GHz, RBW = 1MHz, VBW = 1MHz, Sweep time = *auto*.
 - b. AV Setting 1GHz- 26GHz, RBW = 1MHz, VBW = 1MHz, Sweep time = *auto*.

Operation Mode: 8-DPSK Mode (Low Channel)

Test Date: 2012-06-13

Temperature: 20°C

Humidity: 70 % RH

Freq. (MHz)	Ant. Pol H/V	Peak Reading (dBuV)	AV Reading (dBuV)	Ant. / CL CF (dB)	Actual Fs		Peak Limit (dBuV/m)	AV Limit (dBuV/m)	AV Margin (dB)
					Peak (dBuV/m)	AV (dBuV/m)			
2402.00	H	89.76	67.54	9.08	98.84	76.62	114.00	94.00	-17.38
1612.50	H	60.33	39.59	7.02	67.35	46.61	74.00	54.00	-7.39
N/A									>20
2402.00	V	88.28	68.59	9.08	97.36	77.67	114.00	94.00	-16.33
1612.50	V	59.65	38.34	7.02	66.67	45.36	74.00	54.00	-8.64
N/A									>20

Notes:

1. Measuring frequencies from 1 GHz to the 10th harmonic of highest fundamental frequency.
2. Measurements above show only up to 6 maximum emissions noted, or would be lesser if no specific emissions from the EUT are recorded (ie: margin>20dB from the applicable limit) and considered that's already beyond the background noise floor.
3. Radiated emissions measured in frequency above 1000MHz were made with an instrument using Peak detector mode and average detector mode of the emission shown in Actual FS column.
4. Spectrum setting:
 - a. Peak Setting 1GHz - 26GHz, RBW = 1MHz, VBW = 1MHz, Sweep time = *auto*.
 - b. AV Setting 1GHz- 26GHz, RBW = 1MHz, VBW = 1MHz, Sweep time = *auto*.

Operation Mode: 8-DPSK Mode (Mid Channel)

Test Date: 2012-06-13

Temperature: 20°C

Humidity: 70 % RH

Freq. (MHz)	Ant. Pol H/V	Peak	AV	Ant. / CL	Actual Fs		Peak	AV	AV
		Reading	Reading	CF	Peak (dBuV/m)	AV (dBuV/m)	Limit	Limit	Margin
		(dBuV)	(dBuV)	(dB)			(dBuV/m)	(dBuV/m)	(dB)
2441.00	H	91.27	68.65	9.31	100.58	77.96	114.00	94.00	-16.04
1630.00	H	59.36	40.63	7.25	66.61	47.88	74.00	54.00	-6.12
N/A									>20
2441.00	V	89.55	69.73	9.31	98.86	79.04	114.00	94.00	-14.96
1630.00	V	58.42	39.69	7.25	65.67	46.94	74.00	54.00	-7.06
N/A									>20

Notes:

1. Measuring frequencies from 1 GHz to the 10th harmonic of highest fundamental frequency.
2. Measurements above show only up to 6 maximum emissions noted, or would be lesser if no specific emissions from the EUT are recorded (ie: margin>20dB from the applicable limit) and considered that's already beyond the background noise floor.
3. Radiated emissions measured in frequency above 1000MHz were made with an instrument using Peak detector mode and average detector mode of the emission shown in Actual FS column.
4. Spectrum setting:
 - a. Peak Setting 1GHz - 26GHz, RBW = 1MHz, VBW = 1MHz, Sweep time = *auto*.
 - b. AV Setting 1GHz- 26GHz, RBW = 1MHz, VBW = 1MHz, Sweep time = *auto*.

Operation Mode: 8-DPSK Mode (High Channel)

Test Date: 2012-06-13

Temperature: 20°C

Humidity: 70 % RH

Freq. (MHz)	Ant. Pol H/V	Peak Reading (dBuV)	AV Reading (dBuV)	Ant. / CL CF (dB)	Actual Fs		Peak Limit (dBuV/m)	AV Limit (dBuV/m)	AV Margin (dB)
					Peak (dBuV/m)	AV (dBuV/m)			
2480.00	H	90.17	71.59	9.47	99.64	81.06	114.00	94.00	-12.94
1647.50	H	59.14	39.67	7.52	66.66	47.19	74.00	54.00	-6.81
N/A									>20
2480.00	V	89.68	68.36	9.47	99.15	77.83	114.00	94.00	-16.17
1647.50	V	58.46	39.21	7.52	65.98	46.73	74.00	54.00	-7.27
N/A									>20

Notes:

1. Measuring frequencies from 1 GHz to the 10th harmonic of highest fundamental frequency.
2. Measurements above show only up to 6 maximum emissions noted, or would be lesser if no specific emissions from the EUT are recorded (ie: margin>20dB from the applicable limit) and considered that's already beyond the background noise floor.
3. Radiated emissions measured in frequency above 1000MHz were made with an instrument using Peak detector mode and average detector mode of the emission shown in Actual FS column.
4. Spectrum setting:
 - a. Peak Setting 1GHz - 26GHz, RBW = 1MHz, VBW = 1MHz, Sweep time = *auto*.
 - b. AV Setting 1GHz- 26GHz, RBW = 1MHz, VBW = 1MHz, Sweep time = *auto*.

5.2 BAND EDGE

5.2.1 REQUIREMENT

According to FCC section 15.249(a), in any 100kHz bandwidth outside the frequency band in which the spread spectrum or digitally modulated intentional radiator is operating, the radio frequency power that is produced by the intentional radiator shall be at least 20dB below that in the 100kHz bandwidth within the band that contains the highest level of the desired power, based on either an RF conducted or a radiated measurement.

5.2.2 TEST DESCRIPTION

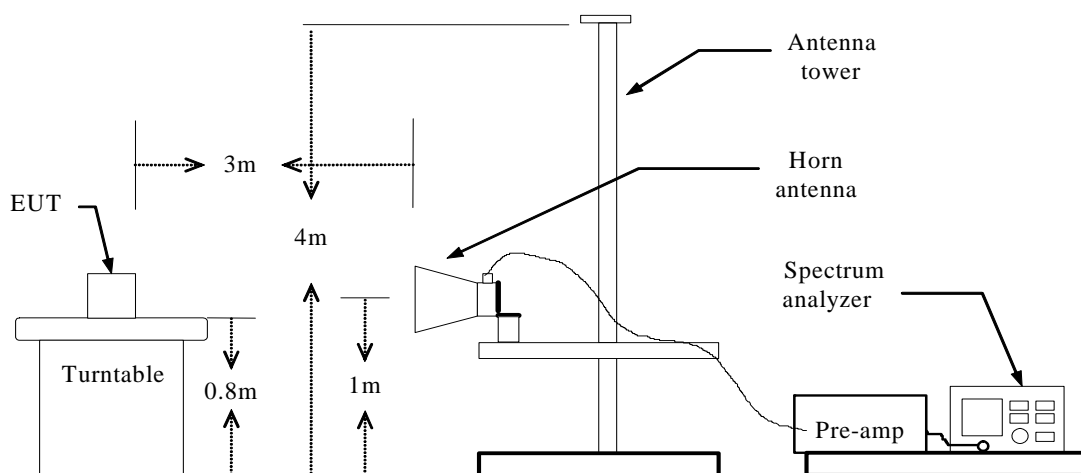

5.2.3 TEST RESULT

The EUT operates at CW test mode. The lowest and highest channels are tested to verify the band edge emissions.

A. Test Verdict:

Test Mode		Channel Marked Frequency	Limit (dBuV/m)	Test Result Highest Emission (dBuV/m)			
				Vertical		Horizontal	
				Peak	Average	Peak	Average
GFSK Mode	Low Channel	2390MHz	74(Peak) 54(Average)	62.02	51.86	64.62	52.31
	High Channel	2483.5MHz		63.84	50.21	61.88	51.94
$\pi/4$ -DQPSK Mode	Low Channel	2390MHz		62.00	51.33	63.55	52.57
	High Channel	2483.5MHz		62.54	50.78	62.34	51.63
8-DPSK Mode	Low Channel	2390MHz		61.95	51.65	64.23	52.44
	High Channel	2483.5MHz		62.28	49.34	61.93	51.38

B. Test Plots:

GFSK Mode:

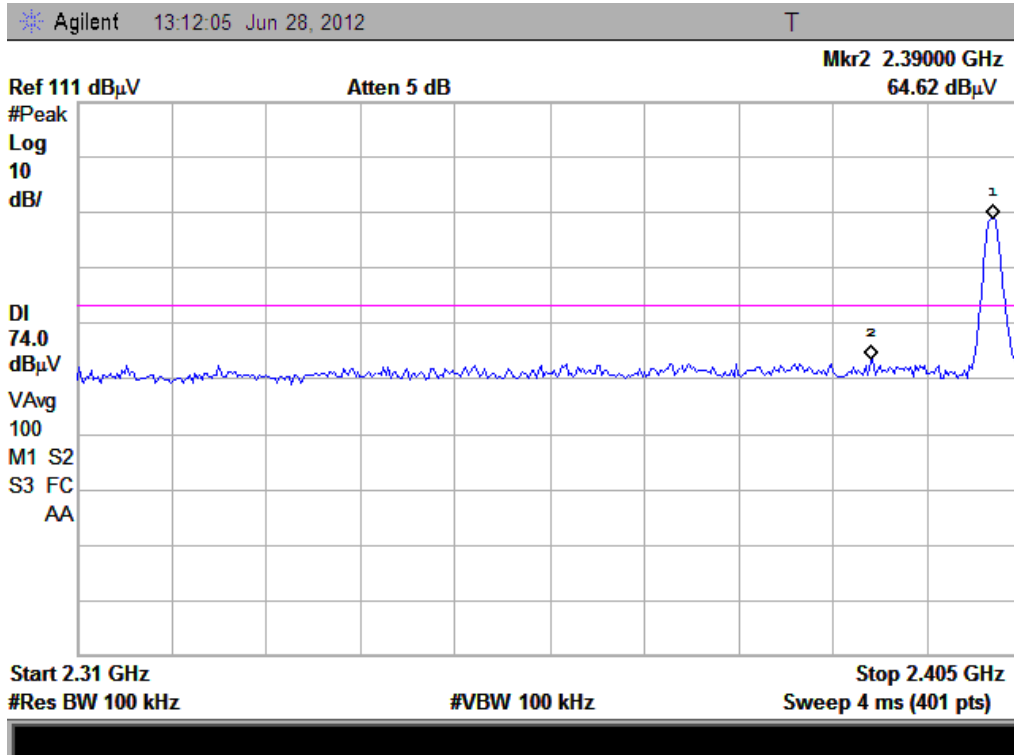

(CH Low, Horizontal, Peak)

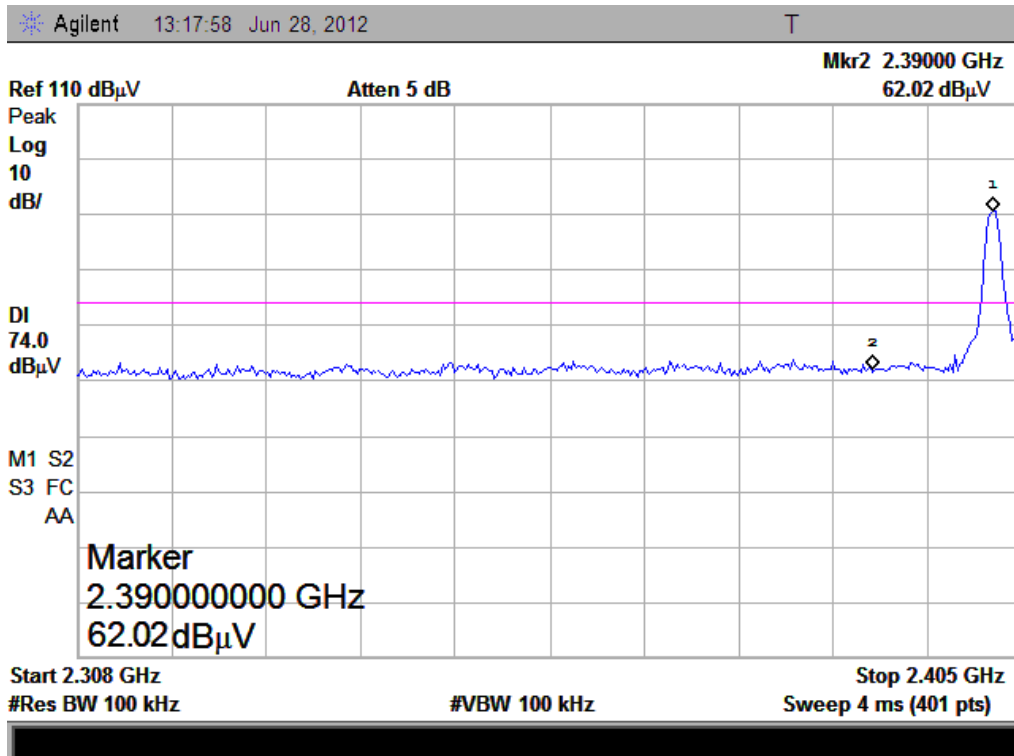

(CH Low, Vertical, Peak)

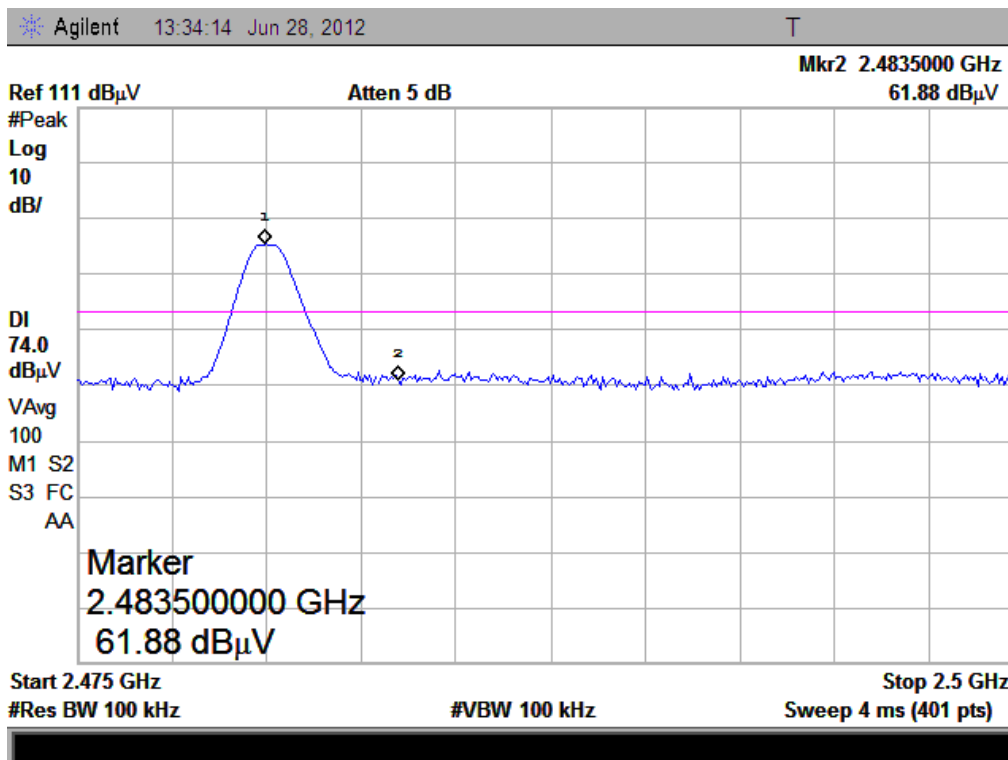

(CH High, Horizontal, Peak)

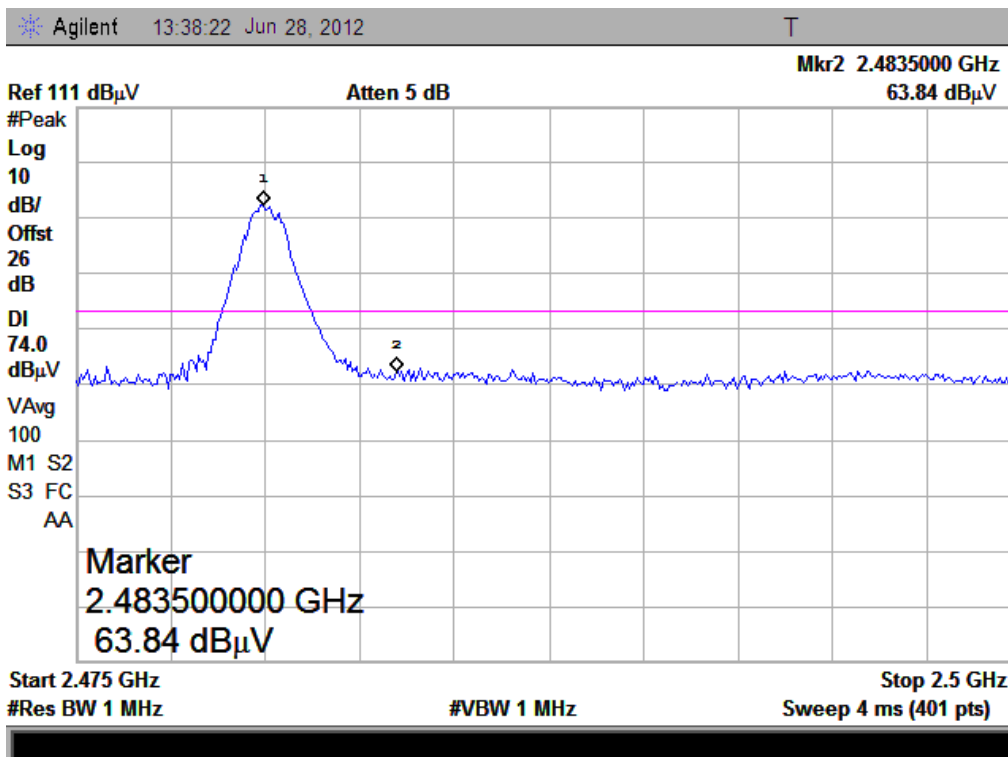

(CH High, Vertical, Peak)

$\pi/4$ -DQPSK Mode:

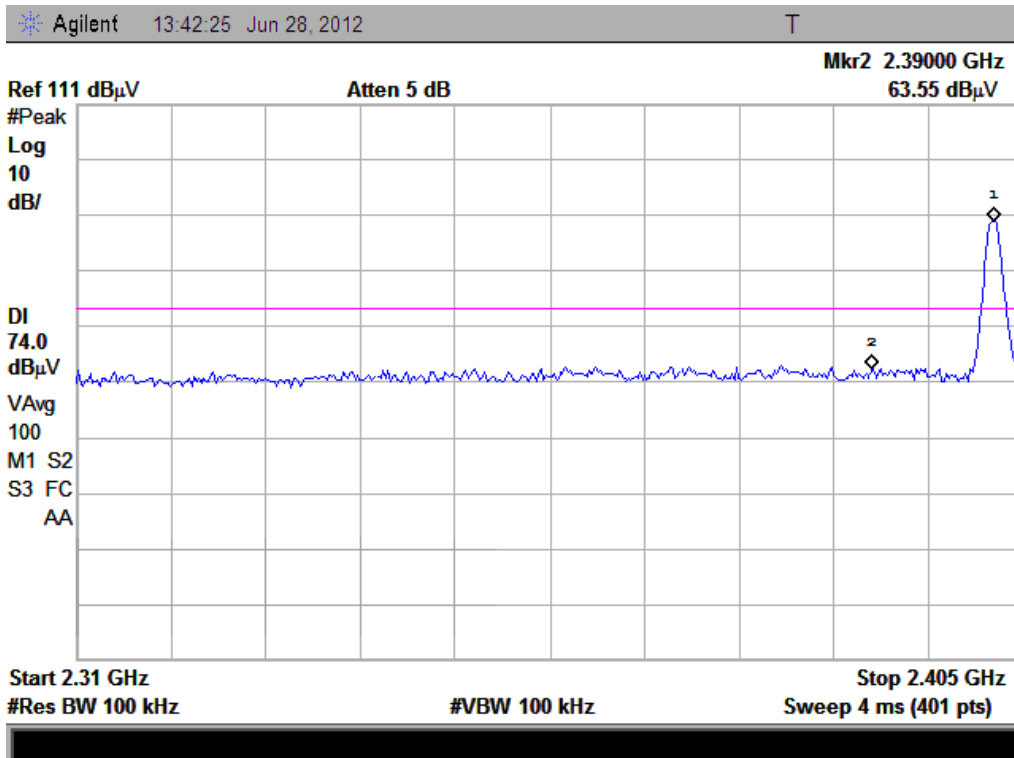

(CH Low, Horizontal, Peak)

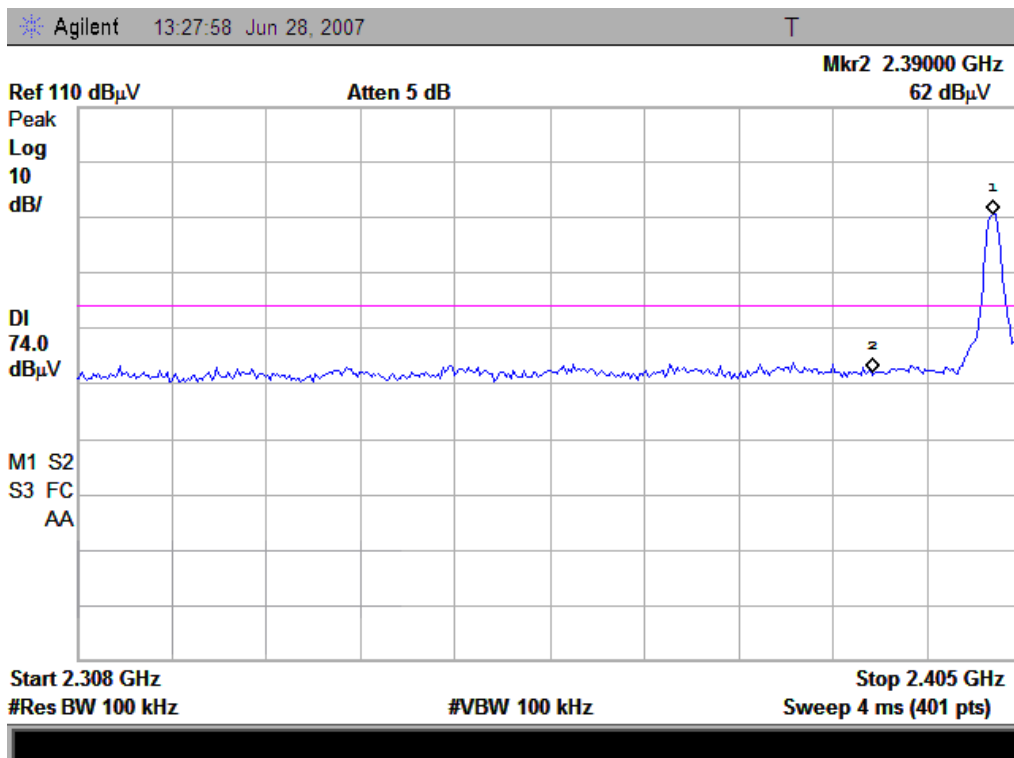

(CH Low, Vertical, Peak)

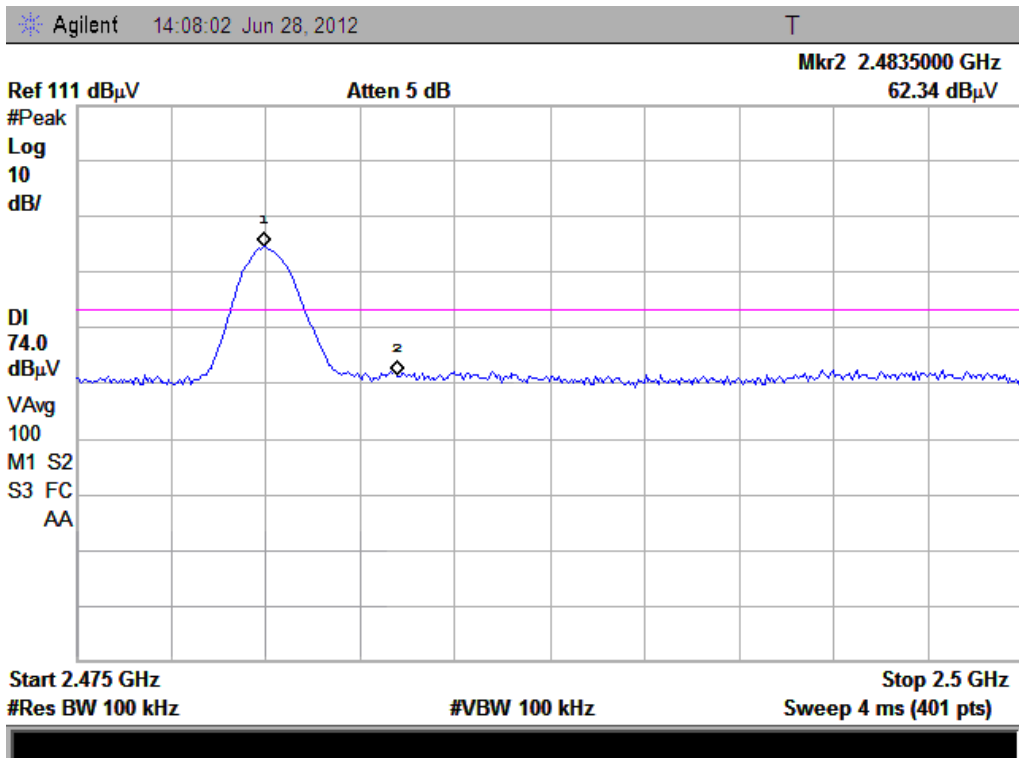

(CH High, Horizontal, Peak)

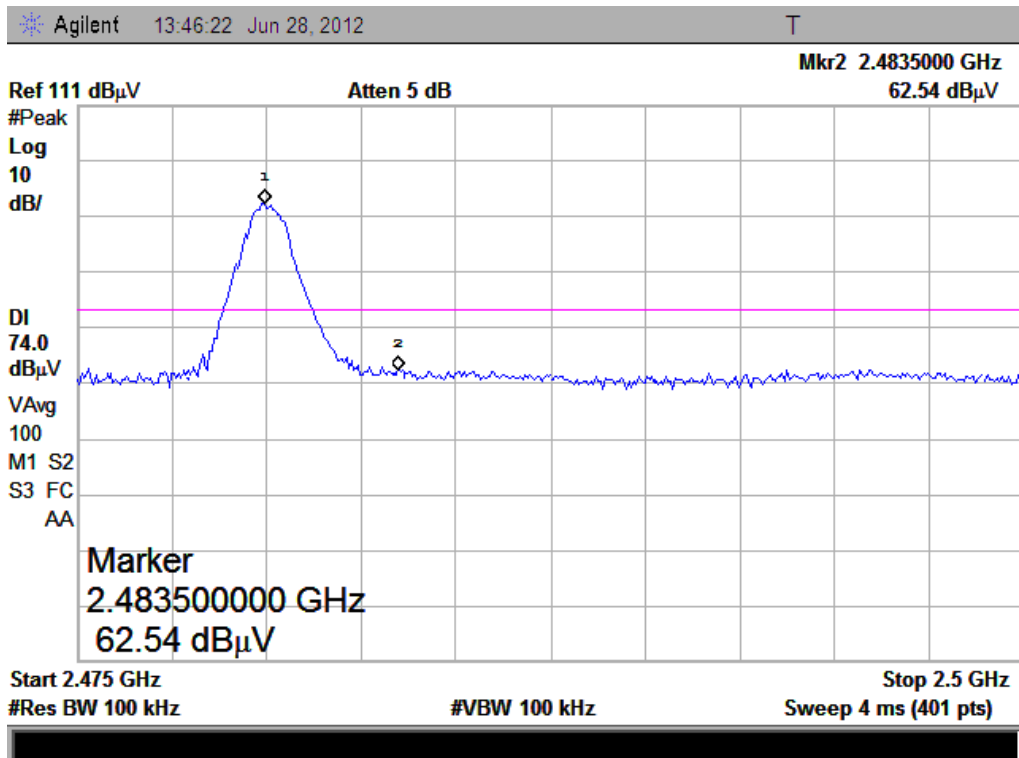

(CH High, Vertical, Peak)

8-DPSK Mode:

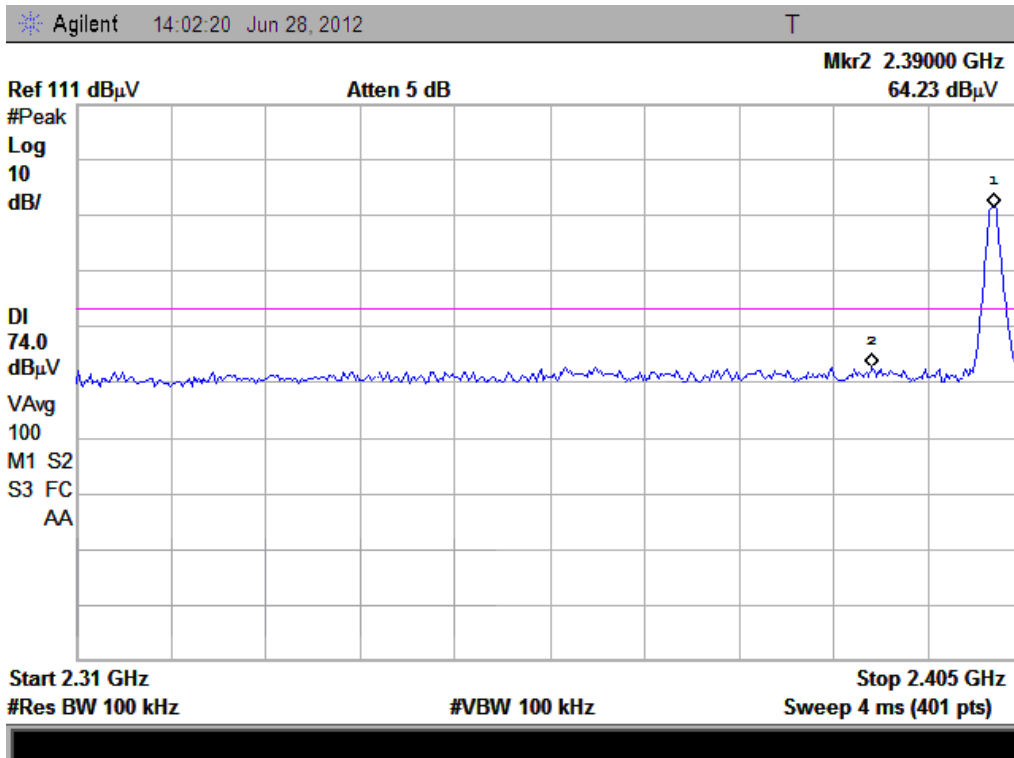

(CH Low, Horizontal, Peak)

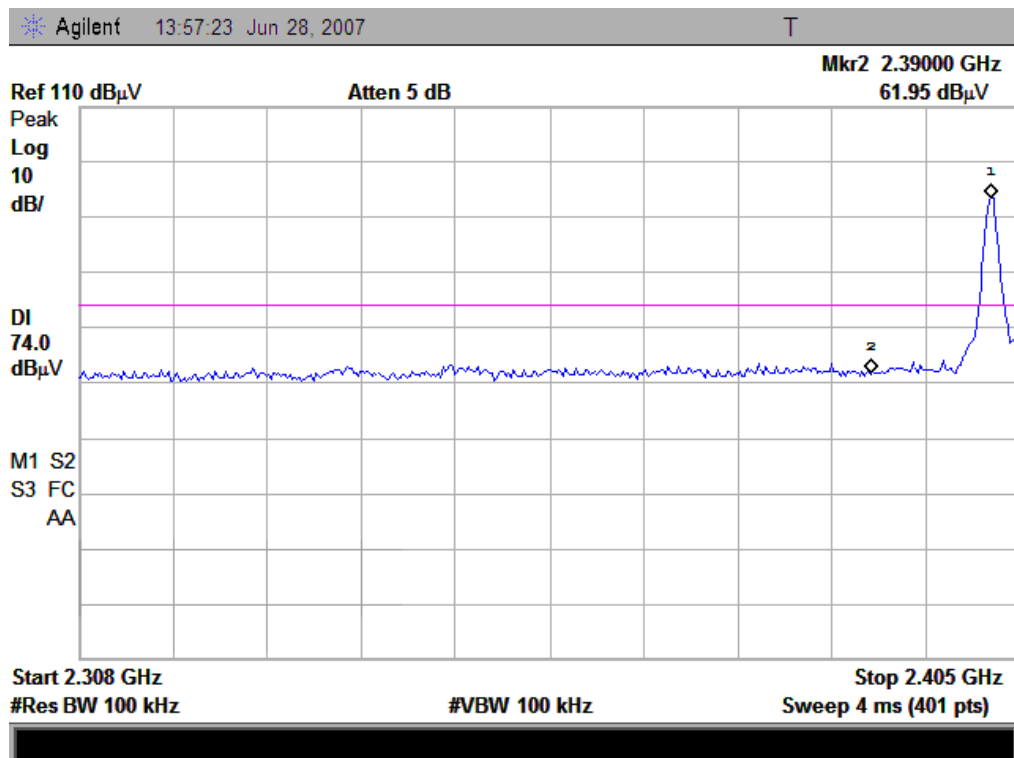

(CH Low, Vertical, Peak)

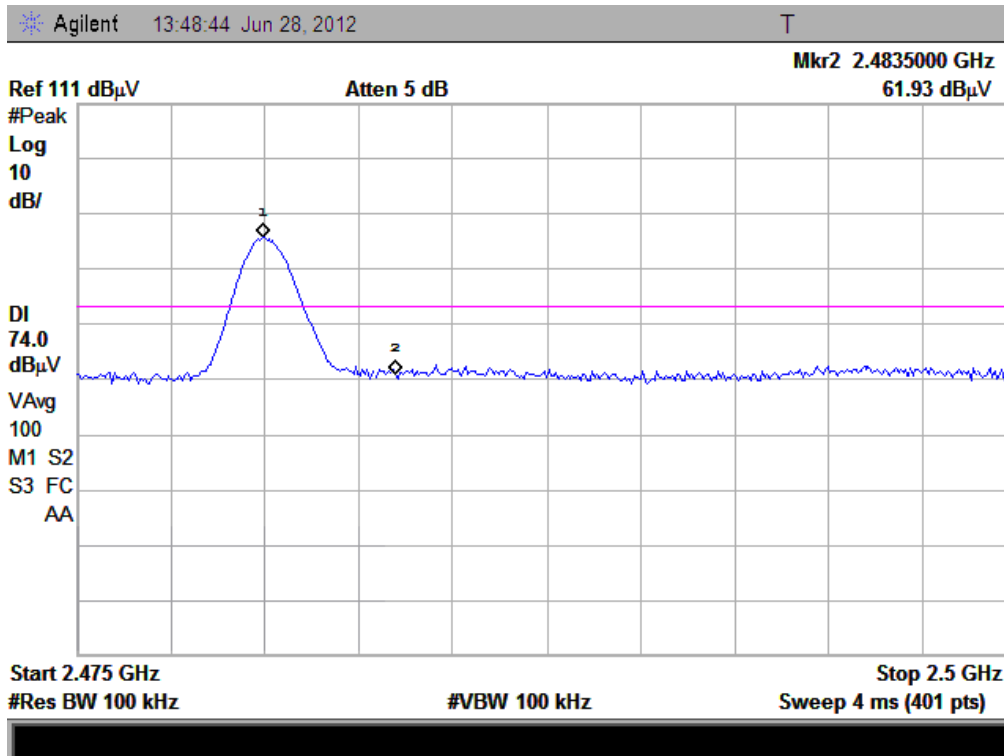

(CH High, Horizontal, Peak)

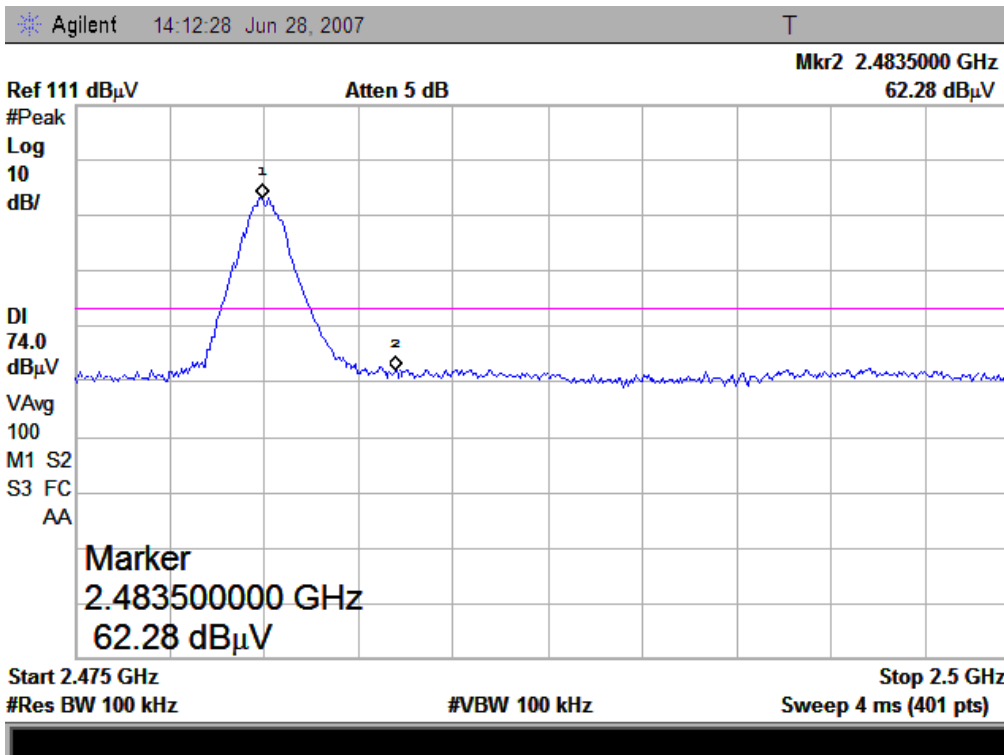

(CH High, Vertical, Peak)

5.3 LINE CONDUCTED EMISSION TEST

5.3.1 LIMITS OF LINE CONDUCTED EMISSION TEST

Frequency	Maximum RF Line Voltage	
	Q.P.(dBuV)	Average(dBuV)
150kHz-500kHz	66-56	56-46
500kHz-5MHz	56	46
5MHz-30MHz	60	50

****Note:** 1. the lower limit shall apply at the transition frequency.

2. The limit decreases linearly with the logarithm of the frequency in the range 0.15 MHz to 0.50 MHz

5.3.2 BLOCK DIAGRAM OF TEST SETUP

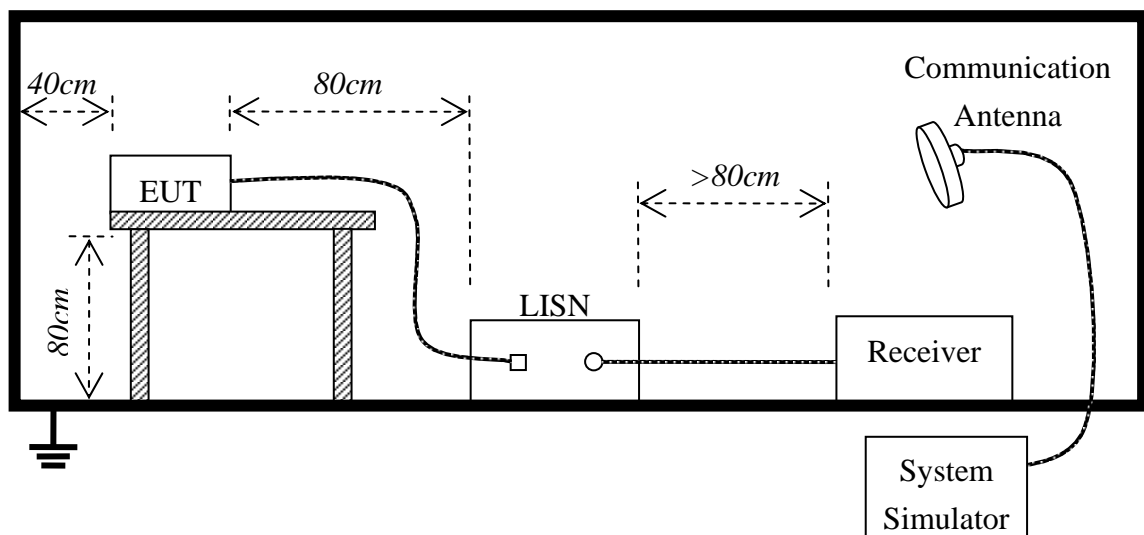

5.3.3 PRELIMINARY PROCEDURE OF LINE CONDUCTED EMISSION TEST

- 1) The equipment was set up as per the test configuration to simulate typical actual usage per the user's manual. When the EUT is a tabletop system, a wooden table with a height of 0.8 meters is used and is placed on the ground plane as per FCC Part 15 (see Test Facility for the dimensions of the ground plane used). When the EUT is floor-standing equipment, it is placed on the ground plane which has a 3-12 mm non-conductive covering to insulate the EUT from the ground plane.
- 2) Support equipment, if needed, was placed as per FCC Part 15.
- 3) All I/O cables were positioned to simulate typical actual usage as per FCC Part 15.
- 4) The EUT received DC 5V power by AC/DC adapter which through a Line Impedance Stabilization Network (LISN) which supplied power source and was grounded to the ground plane.
- 5) All support equipments received power from a second LISN supplying power of AC 120V/60Hz, if any.
- 6) The EUT test program was started. Emissions were measured on each current carrying line of the EUT using a spectrum Analyzer / Receiver connected to the LISN powering the EUT. The LISN has two monitoring points: Line 1 (Hot Side) and Line 2 (Neutral Side). Two scans were taken: one with Line 1 connected to Analyzer / Receiver and Line 2 connected to a 50 ohm load; the second scan had Line 1 connected to a 50 ohm load and Line 2 connected to the Analyzer / Receiver.
- 7) Analyzer / Receiver scanned from 150 kHz to 30 MHz for emissions in each of the test modes.
- 8) During the above scans, the emissions were maximized by cable manipulation.

5.3.4 FINAL PROCEDURE OF LINE CONDUCTED EMISSION TEST

A scan was taken on both power lines, Line 1 and Line 2, recording at least the six highest emissions. Emission frequency and amplitude were recorded into a computer in which correction factors were used to calculate the emission level and compare reading to the applicable limit. If EUT emission level was less -2dB to the A.V. limit in Peak mode, then the emission signal was re-checked using Q.P and Average detector.

The test data of the worst case condition(s) was reported on the Summary Data page.

5.3.5 TEST RESULT OF LINE CONDUCTED EMISSION TEST

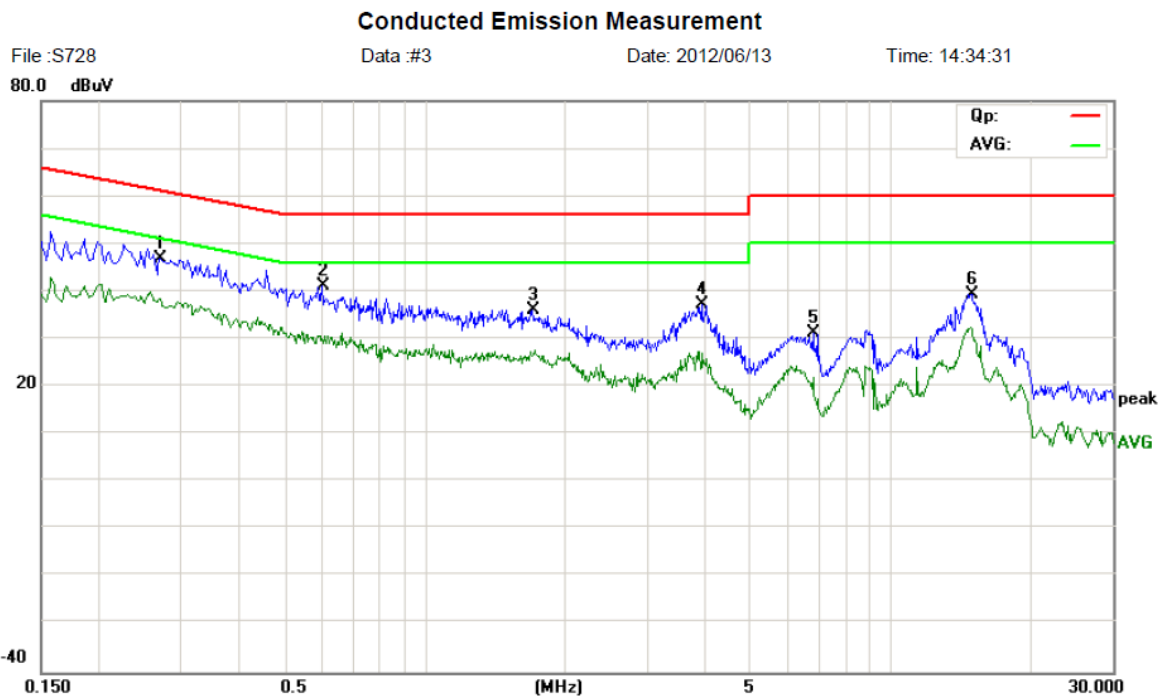

Site site #1 Phase: **N** Temperature: 26
 Limit: FCC Part15 B Class B QP Power: 1 Humidity: 60 %
 EUT:
 M/N: S728
 Mode: Bluetooth mode
 Note:

No.	Mk.	Freq. MHz	Reading Level dBuV	Correct Factor dB	Measure- ment dBuV	Limit dBuV	Over dB	Detector	Comment
1	*	0.2700	35.33	11.53	46.86	61.12	-14.26	peak	
2		0.6020	31.29	10.00	41.29	56.00	-14.71	peak	
3		1.7060	26.84	9.29	36.13	56.00	-19.87	peak	
4		3.9380	26.25	10.94	37.19	56.00	-18.81	peak	
5		6.8260	20.48	10.90	31.38	60.00	-28.62	peak	
6		14.9540	30.48	9.00	39.48	60.00	-20.52	peak	

*:Maximum data x:Over limit !:over margin

Conducted Emission Measurement

File :S728

Data #4

Date: 2012/06/13

Time: 14:42:24

80.0 dBuV

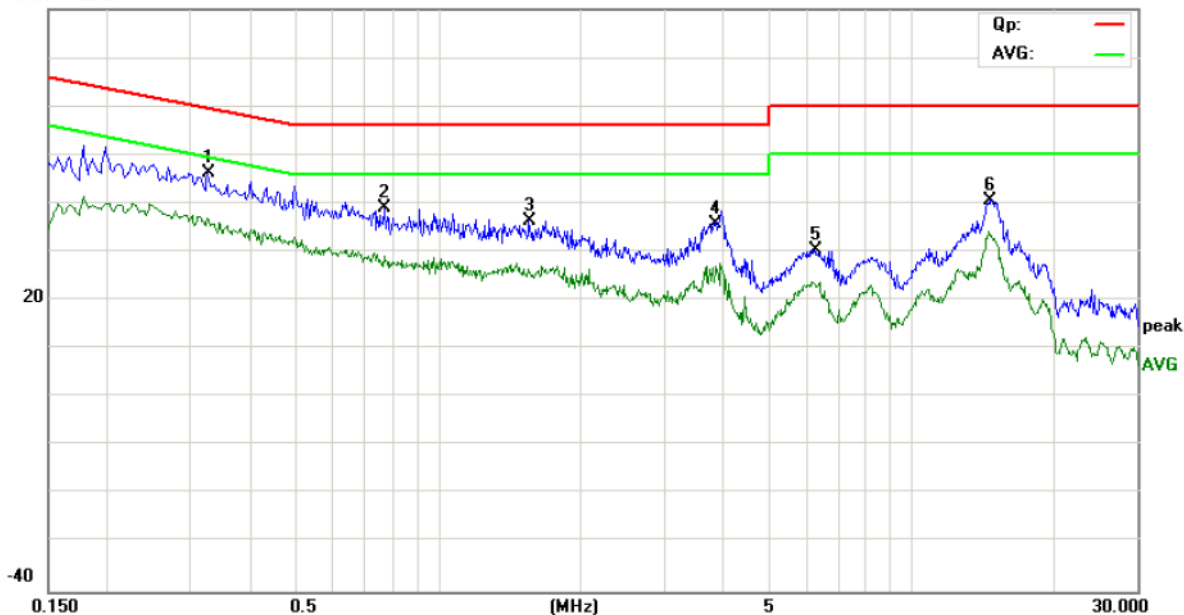

Site site #1

Phase: L1

Temperature: 26

Limit: FCC Part15 B Class B QP

Power: 1

Humidity: 60 %

EUT:

M/N: S728

Mode: Bluetooth mode

Note:

No.	Mk.	Freq. MHz	Reading Level dBuV	Correct Factor dB	Measure- ment dBuV	Limit dBuV	Over dB	Detector	Comment
1	*	0.3260	35.15	11.16	46.31	59.55	-13.24	peak	
2		0.7700	29.11	10.00	39.11	56.00	-16.89	peak	
3		1.5540	26.79	9.45	36.24	56.00	-19.76	peak	
4		3.8260	24.81	10.83	35.64	56.00	-20.36	peak	
5		6.2460	19.16	11.25	30.41	60.00	-29.59	peak	
6		14.6580	31.53	9.00	40.53	60.00	-19.47	peak	

*:Maximum data x:Over limit !:over margin

5.4 20dB BANDWIDTH

5.4.1 DEFINITION

Intentional radiators operating under the alternative provisions to the general emission limits, as contained in §§ 15.217 through 15.257 and in Subpart E of this part, must be designed to ensure that the 20 dB bandwidth of the emission, or whatever bandwidth may otherwise be specified in the specific rule section under which the equipment operates, is contained within the frequency band designated in the rule section under which the equipment is operated.

5.4.2 TEST DESCRIPTION

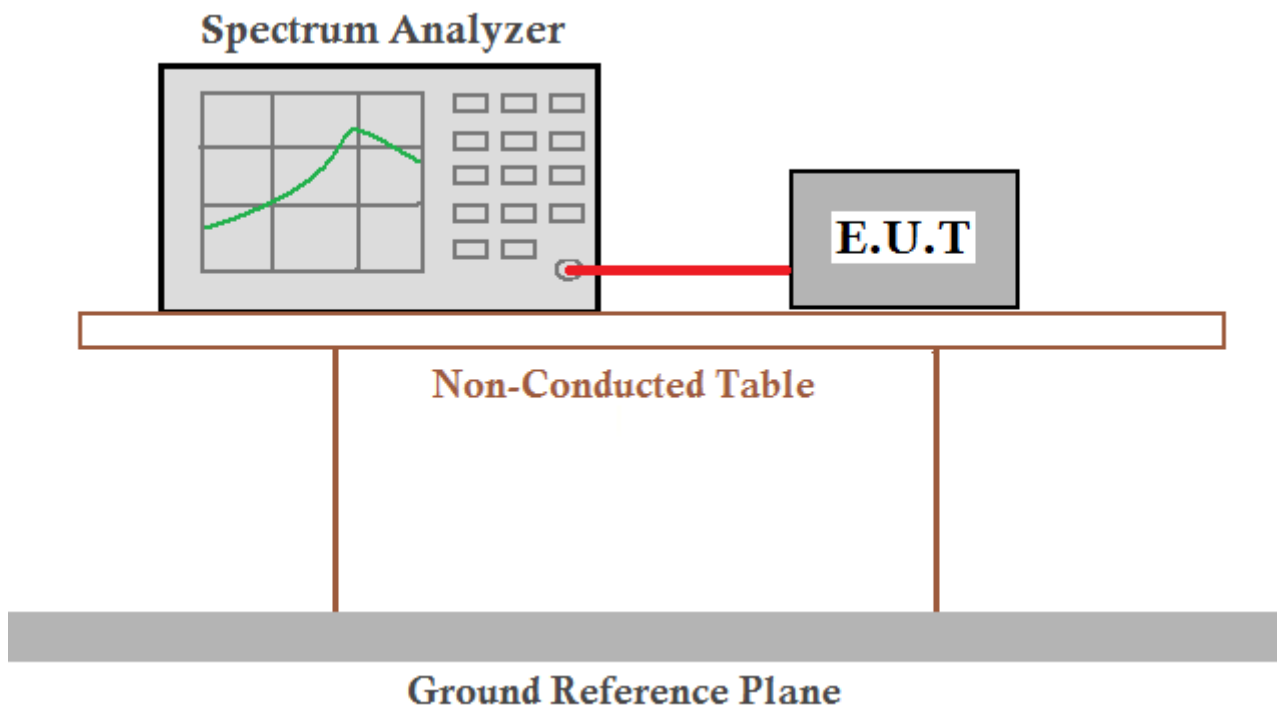

5.4.3 TEST RESULT

GFSK Mode:

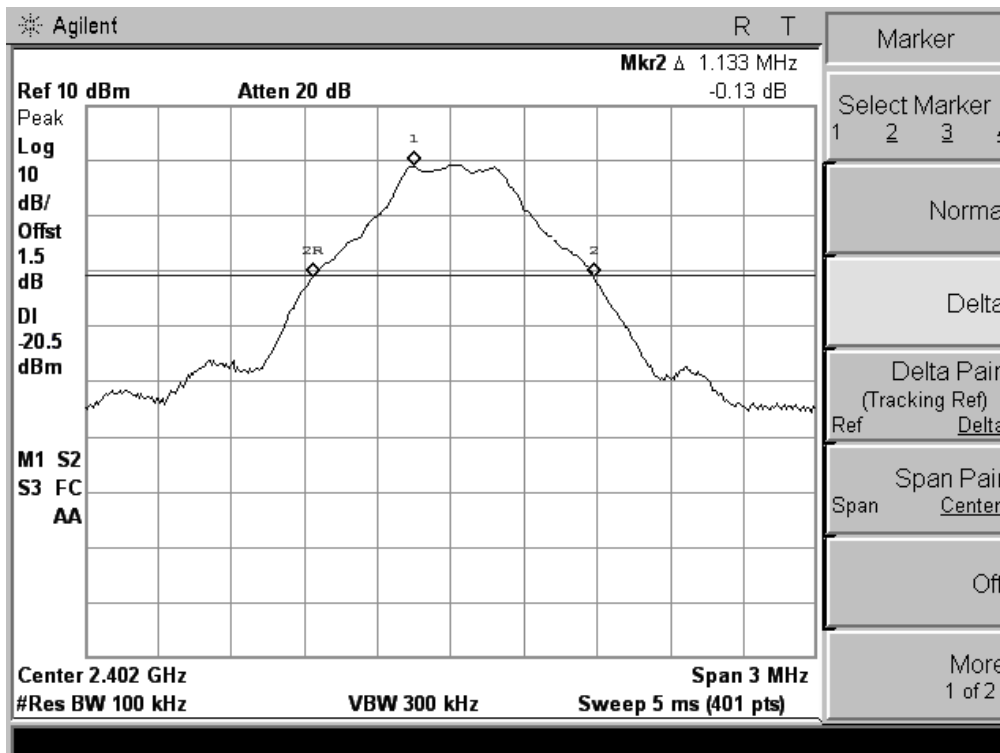

(CH Low)

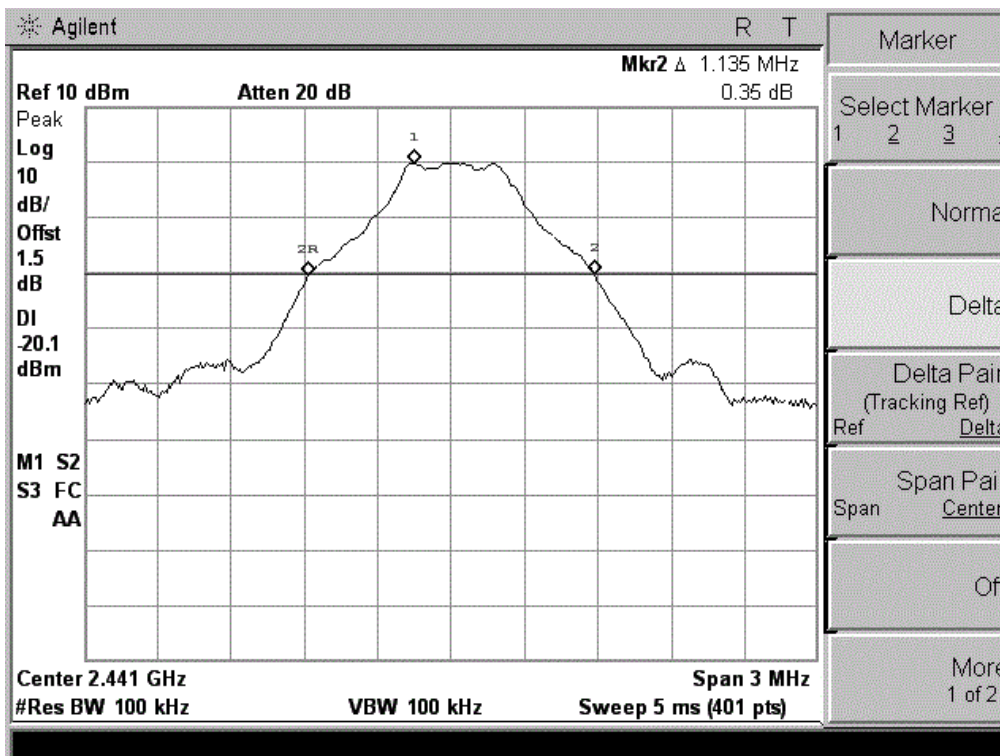

(CH Mid)

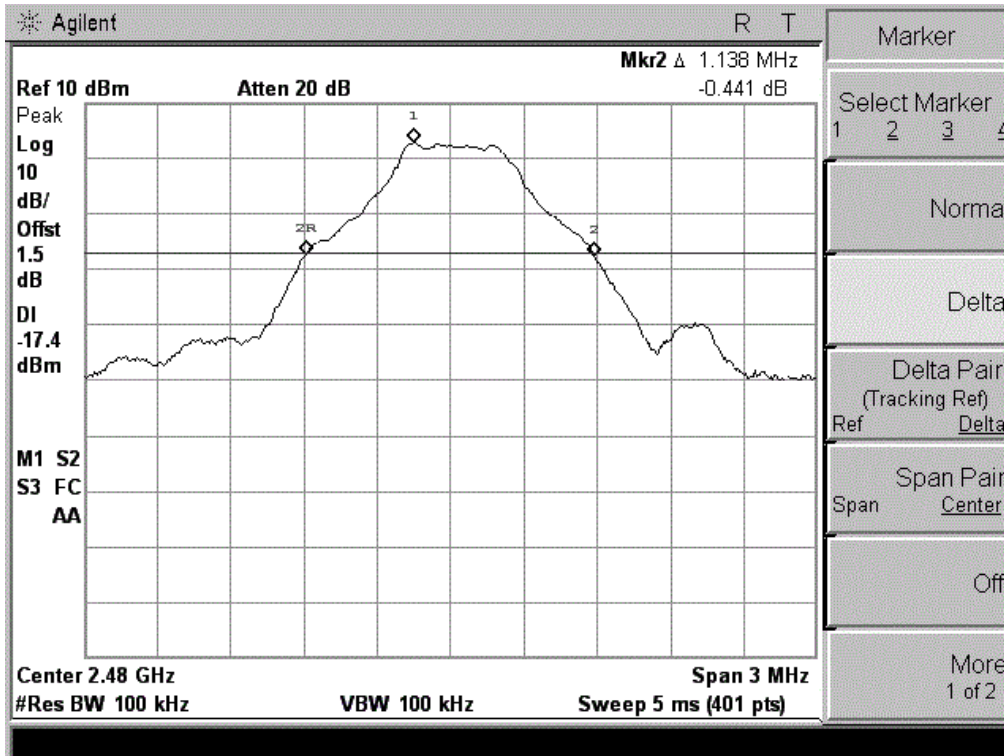

(CH High)

$\pi/4$ -DQPSK Mode:

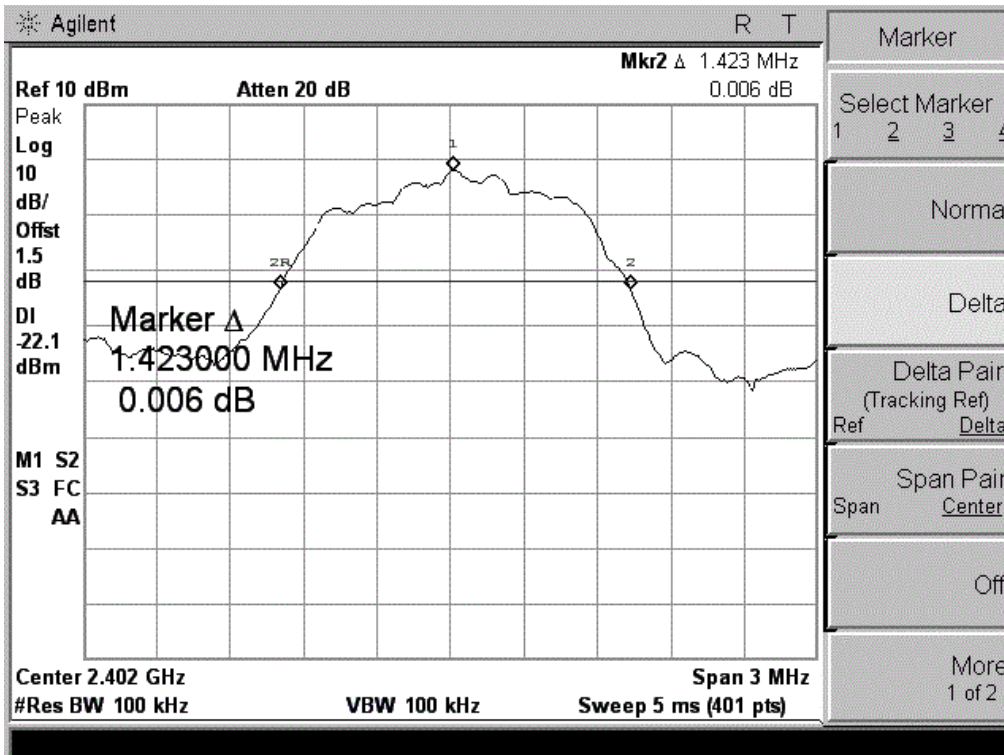

(Plot A: CH Low)

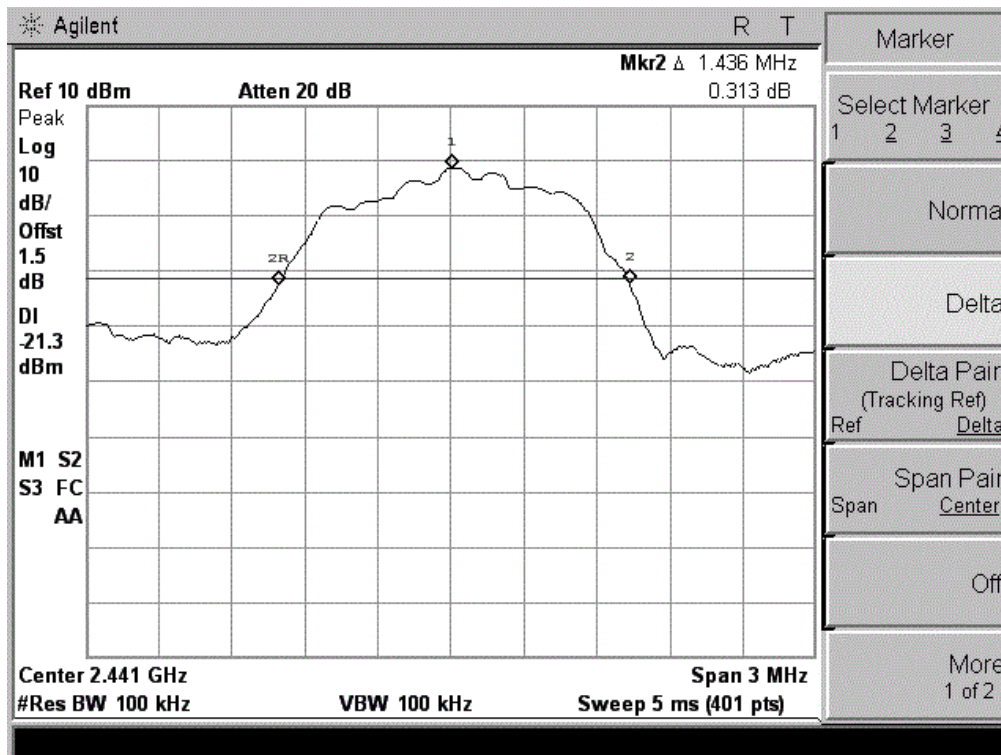

(Plot B: CH Mid)

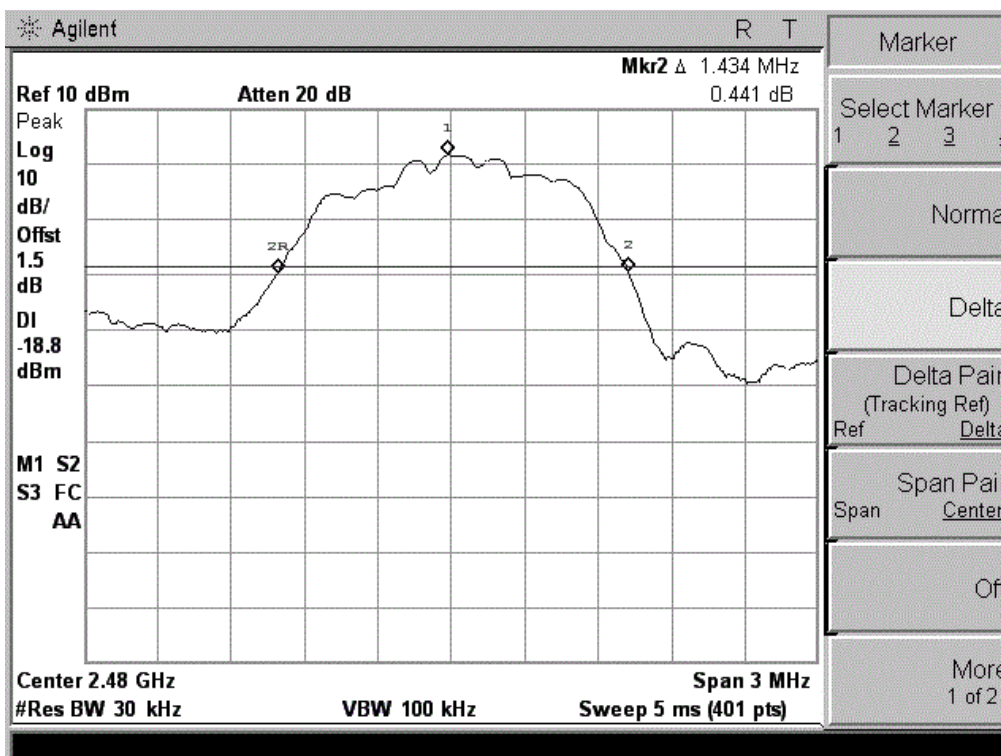

(Plot C: CH High)

8-DPSK Mode:

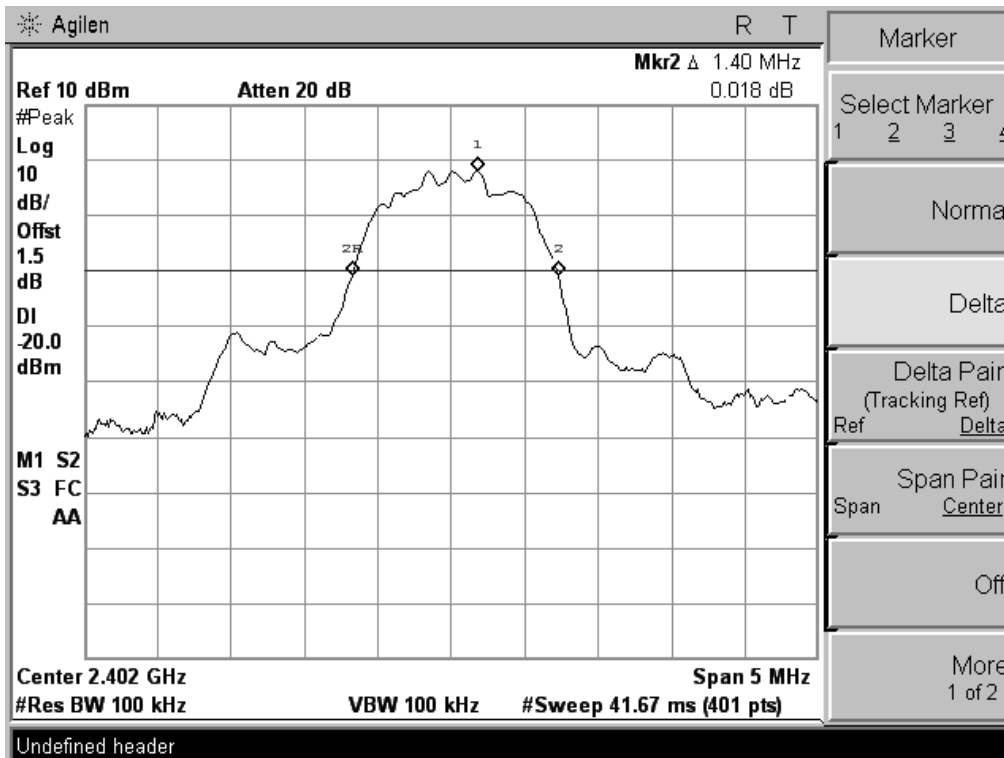

(CH Low)

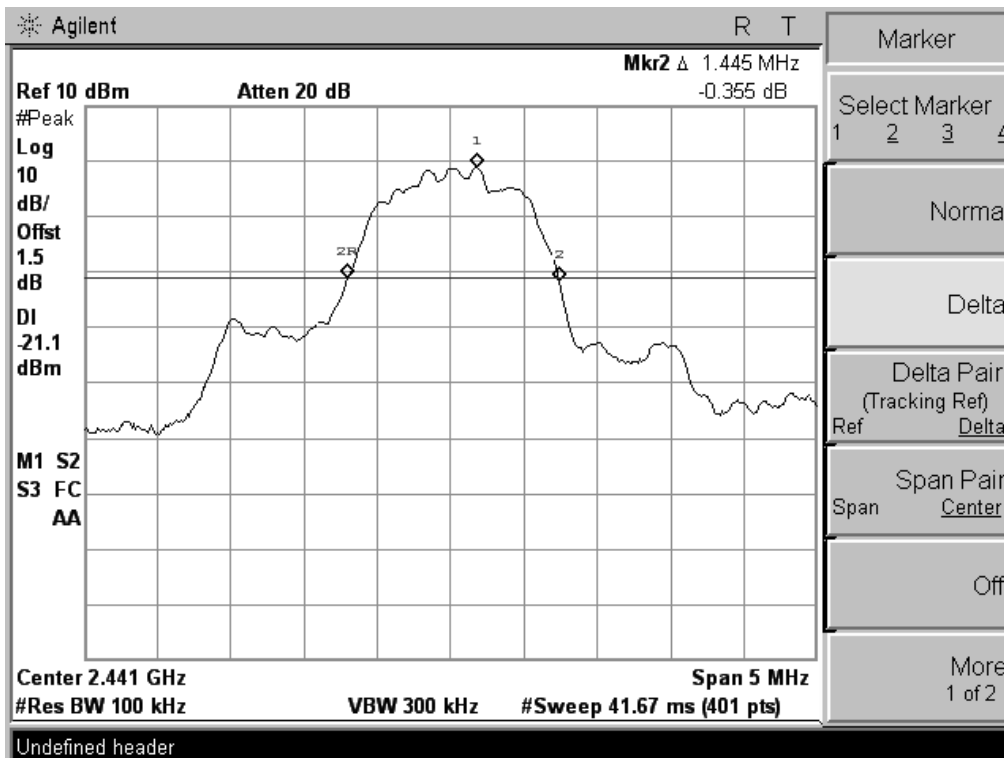

(Plot B: CH Mid)

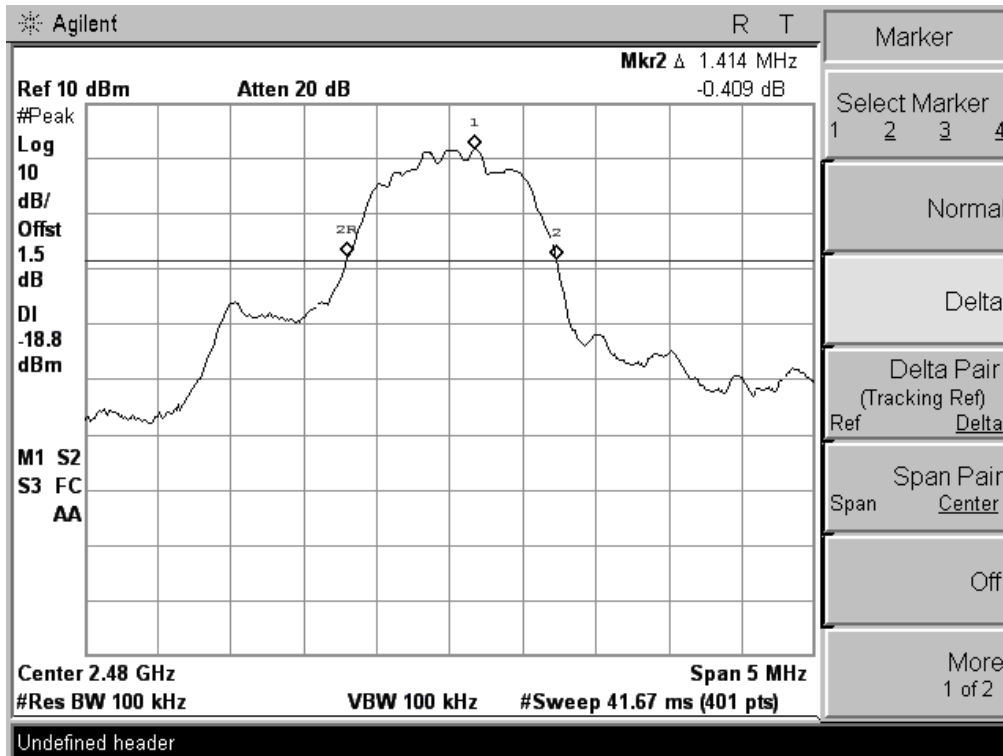

(Plot C: CH High)

**APPENDIX 1
PHOTOGRAPHS OF TEST SETUP**

CE TEST SETUP

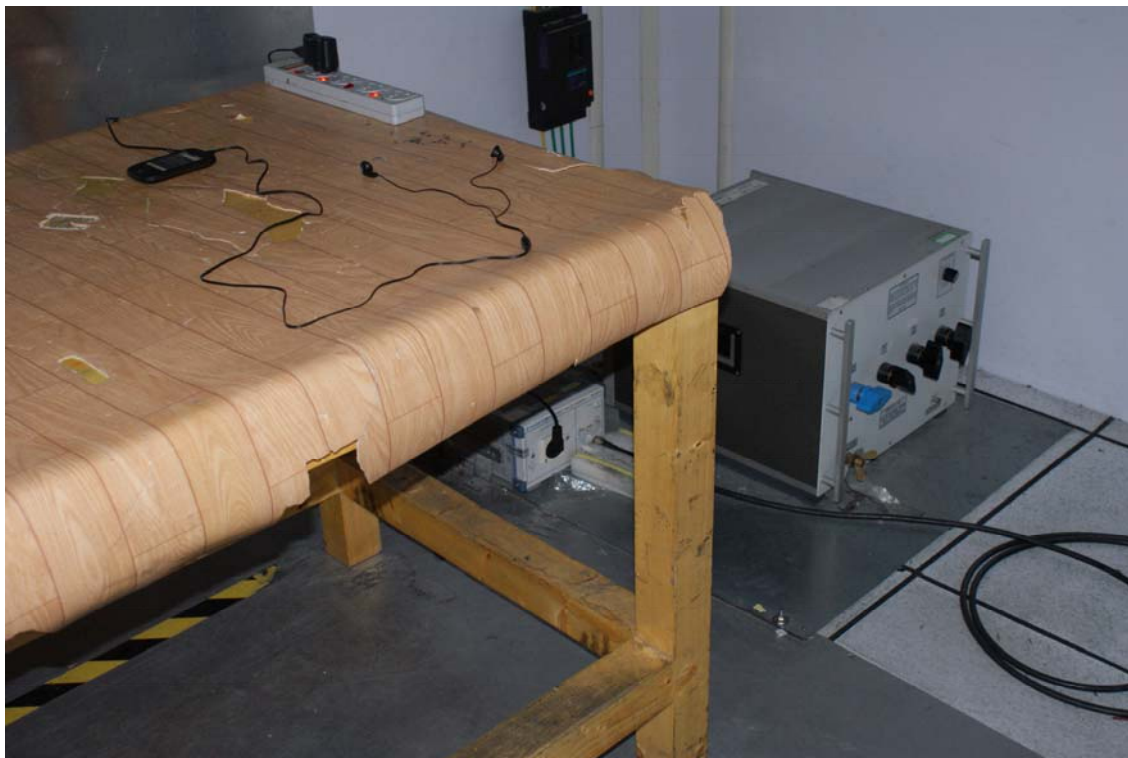

RE TEST SETUP





**APPENDIX 2
PHOTOGRAPHS OF EUT**

FRONT VIEW OF SAMPLE



BACK VIEW OF SAMPLE



LEFT VIEW OF SAMPLE



RIGHT VIEW OF SAMPLE



UP VIEW OF SAMPLE



DOWN VIEW OF SAMPLE



PHOTO OF HEADPHONE



PHOTO OF ADAPTER



PHOTO OF BATTERY



INTERNAL PHOTO OF SAMPLE - 1



INTERNAL PHOTO OF SAMPLE -2



INTERNAL PHOTO OF SAMPLE - 3



INTERNAL PHOTO OF SAMPLE - 4



INTERNAL PHOTO OF SAMPLE - 5

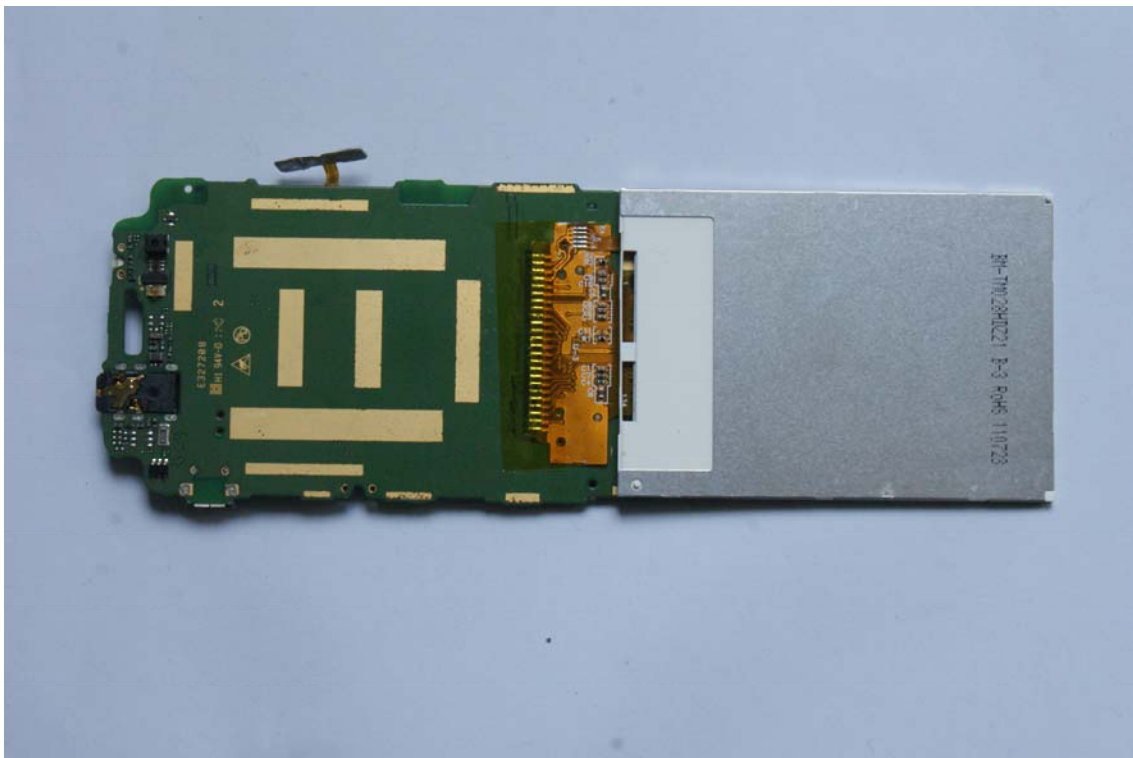

INTERNAL PHOTO OF SAMPLE - 6



INTERNAL PHOTO OF ADAPTER - 1

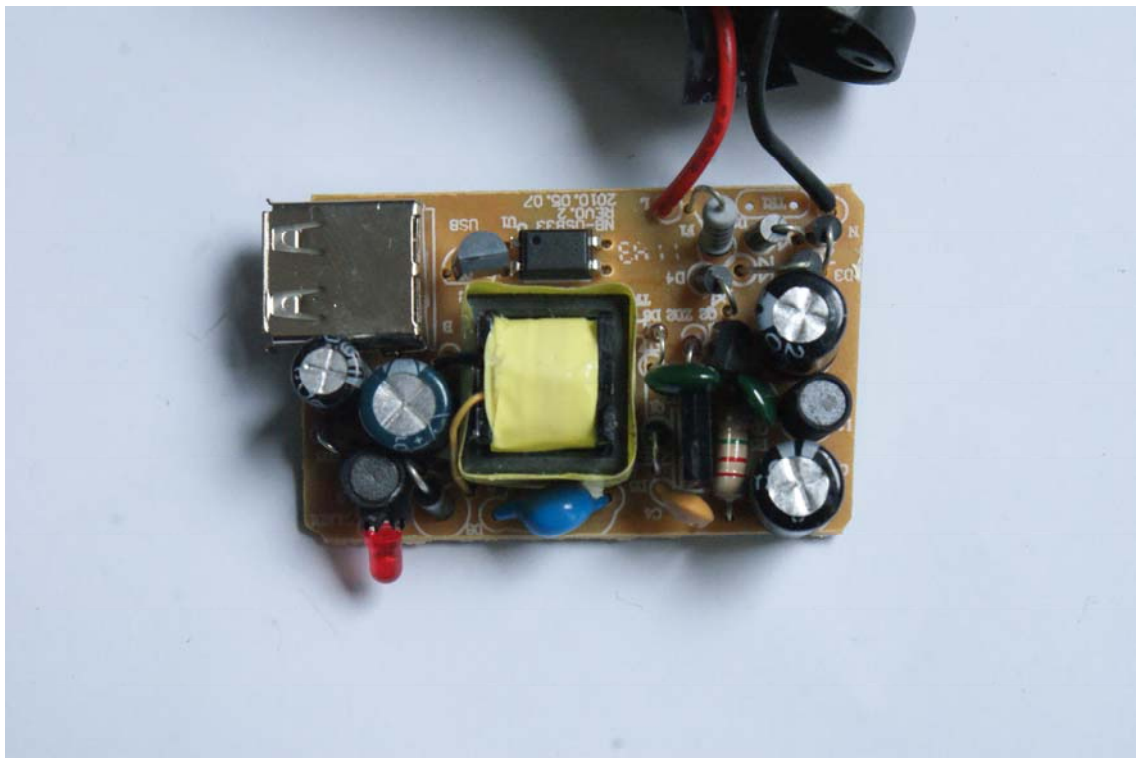

INTERNAL PHOTO OF ADAPTER - 2

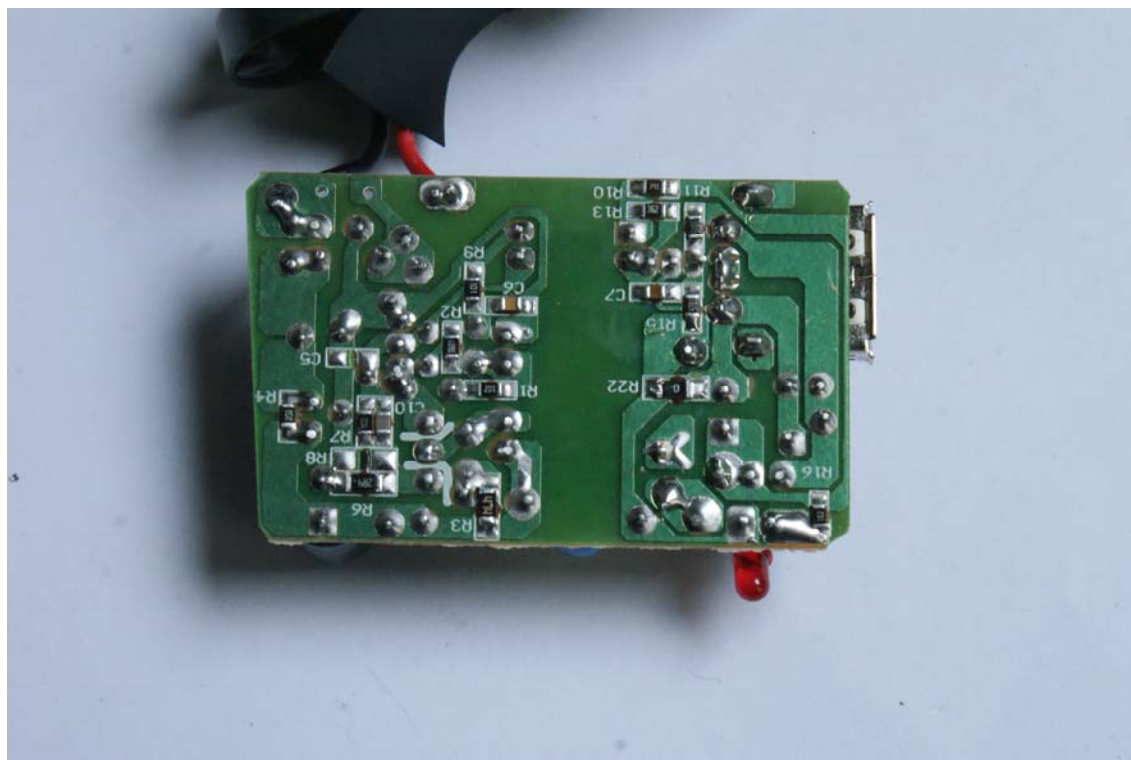

-----END OF REPORT-----