



# TEST REPORT

**Report Reference No.**..... : **TRE1712002904** R/C.....: 23847  
**FCC ID**..... : **WA6S5701**  
**Applicant's name**..... : **Verykool USA Inc**  
 Address..... : 3636 Nobel Drive,Suite 325, San Diego,CA 92122 USA  
 Manufacturer..... : HUAWO TECHNOLOGY LIMITED  
 Address..... : 3 floor west,B building,New world shopping plaza,Gushu 2nd road,  
 Xixiang street,Baoan District,Shenzhen,China  
**Test item description** ..... : **Mobile Phone**  
 Trade Mark ..... : Verykool  
 Model/Type reference..... : s5702  
 Listed Model(s)..... : s5701  
**Standard** ..... : **FCC CFR Title 47 Part 15 Subpart C Section 15.247**  
 Date of receipt of test sample..... : Dec.05, 2017  
 Date of testing..... : Dec.05, 2017 - Dec.25, 2017  
 Date of issue..... : Dec.26, 2017  
**Result**..... : **PASS**

Compiled by  
 ( position+printedname+signature)....: File administrators Candy Liu *Candy Liu*  
 Supervised by  
 (position+printedname+signature)....: Project Engineer : Edward Pan *Edward Pan*  
 Approved by  
 (Position+Printed name+Signature): RF Manager Hans Hu *Hans Hu*

**Testing Laboratory Name** ..... : **Shenzhen Huatongwei International Inspection Co., Ltd.**  
 Address..... : 1/F, Bldg 3, Hongfa Hi-tech Industrial Park, Genyu Road, Tianliao,  
 Gongming, Shenzhen, China

**Shenzhen Huatongwei International Inspection Co., Ltd. All rights reserved.**  
 This publication may be reproduced in whole or in part for non-commercial purposes as long as the Shenzhen Huatongwei International Inspection Co., Ltd. is acknowledged as copyright owner and source of the material. Shenzhen Huatongwei International Inspection Co., Ltd. takes no responsibility for and will not assume liability for damages resulting from the reader's interpretation of the reproduced material due to its placement and context.  
*The test report merely correspond to the test sample.*

## Contents

<b>1.</b>	<b><u>TEST STANDARDS AND REPORT VERSION</u></b>	<b>3</b>
1.1.	Test Standards	3
1.2.	Report version	3
<b>2.</b>	<b><u>TEST DESCRIPTION</u></b>	<b>4</b>
<b>3.</b>	<b><u>SUMMARY</u></b>	<b>5</b>
3.1.	Client Information	5
3.2.	Product Description	5
3.3.	Operation state	6
3.4.	EUT configuration	6
3.5.	Modifications	6
<b>4.</b>	<b><u>TEST ENVIRONMENT</u></b>	<b>7</b>
4.1.	Address of the test laboratory	7
4.2.	Test Facility	7
4.3.	Environmental conditions	8
4.4.	Statement of the measurement uncertainty	8
4.5.	Equipments Used during the Test	9
<b>5.</b>	<b><u>TEST CONDITIONS AND RESULTS</u></b>	<b>11</b>
5.1.	Antenna requirement	11
5.2.	Conducted Emissions (AC Main)	12
5.3.	Conducted Peak Output Power	15
5.4.	20 dB Bandwidth	19
5.5.	Carrier Frequencies Separation	23
5.6.	Hopping Channel Number	25
5.7.	Dwell Time	27
5.8.	Pseudorandom Frequency Hopping Sequence	34
5.9.	Restricted band (radiated)	35
5.10.	Band edge and Spurious Emissions (conducted)	40
5.11.	Spurious Emissions (radiated)	56
<b>6.</b>	<b><u>TEST SETUP PHOTOS</u></b>	<b>60</b>
<b>7.</b>	<b><u>EXTERANAL AND INTERNAL PHOTOS</u></b>	<b>61</b>

## 1. TEST STANDARDS AND REPORT VERSION

### 1.1. Test Standards

The tests were performed according to following standards:

[FCC Rules Part 15.247](#): Frequency Hopping, Direct Spread Spectrum and Hybrid Systems that are in operation within the bands of 902-928 MHz, 2400-2483.5 MHz, and 5725-5850 MHz

[ANSI C63.10-2013](#): American National Standard for Testing Unlicensed Wireless Devices

### 1.2. Report version

Version No.	Date of issue	Description
00	Dec.26, 2017	Original

## **2. TEST DESCRIPTION**

<b>Test Item</b>	<b>Section in CFR 47</b>	<b>Result</b>	<b>Test Engineer</b>
Antenna Requirement	15.203/15.247 (c)	Pass	William Wang
AC Power Line Conducted Emissions	15.207	Pass	William Wang
Conducted Peak Output Power	15.247 (b)(1)	Pass	Baozhu Hu
20 dB Bandwidth	15.247 (a)(1)	Pass	Baozhu Hu
Carrier Frequencies Separation	15.247 (a)(1)	Pass	Baozhu Hu
Hopping Channel Number	15.247 (a)(1)	Pass	Baozhu Hu
Dwell Time	15.247 (a)(1)	Pass	Baozhu Hu
Pseudorandom Frequency Hopping Sequence	15.247(b)(4)	Pass	Baozhu Hu
Restricted band	15.247(d)/15.205	Pass	Baozhu Hu
Radiated Emissions	15.247(d)/15.209	Pass	Baozhu Hu

Note: The measurement uncertainty is not included in the test result.

### 3. SUMMARY

#### 3.1. Client Information

Applicant:	Verykool USA Inc
Address:	3636 Nobel Drive,Suite 325, San Diego,CA 92122 USA
Manufacturer:	HUAWO TECHNOLOGY LIMITED
Address:	3 floor west,B building,New world shopping plaza,Gushu 2nd road, Xixiang street,Baoan District,Shenzhen,China

#### 3.2. Product Description

Name of EUT:	Mobile Phone
Trade Mark:	Verykool
Model No.:	s5702
Listed Model(s):	s5701
IMEI 1 :	352484079998752
IMEI 2 :	352484079999874
Power supply:	DC 3.8V
Adapter information:	Input: 100-240Va.c., 50/60Hz, 0.2A Output: 5Vd.c.,1000mA
Hardware version:	MF0MCCRA1-1
Software version:	s5072_VK_Movi_Dual_SW_V1.0
<b>Bluetooth</b>	
Version:	Supported BT4.1+EDR
Modulation:	GFSK, $\pi/4$ DQPSK, 8DPSK
Operation frequency:	2402MHz~2480MHz
Channel number:	79
Channel separation:	1MHz
Antenna type:	Integral antenna
Antenna gain:	-1.2dBi

### 3.3. Operation state

➤ **Test frequency list**

According to section 15.31(m), regards to the operating frequency range over 10 MHz, must select three channel which were tested. the Lowest frequency, the middle frequency, and the highest frequency of channel were selected to perform the test, please see the above gray bottom.

Channel	Frequency (MHz)
00	2402
01	2403
⋮	⋮
39	2441
⋮	⋮
77	2479
78	2480

➤ **TEST MODE**

For RF test items:
The engineering test program was provided and enabled to make EUT continuous transmit
For AC power line conducted emissions:
The EUT was set to connect with the Bluetooth instrument under large package sizes transmission.
For Radiated suprious emissions test item:
The engineering test program was provided and enabled to make EUT continuous transmit. The EUT in each of three orthogonal axis emissions had been tested ,but only the worst case (X axis) data recorded in the report.

### 3.4. EUT configuration

The following peripheral devices and interface cables were connected during the measurement:

- - supplied by the manufacturer
- - supplied by the lab

/	Manufacturer:	/
	Model No.:	/
/	Manufacturer:	/
	Model No.:	/

### 3.5. Modifications

No modifications were implemented to meet testing criteria.

## **4. TEST ENVIRONMENT**

### **4.1. Address of the test laboratory**

Laboratory: Shenzhen Huatongwei International Inspection Co., Ltd.

Address: 1/F, Bldg 3, Hongfa Hi-tech Industrial Park, Genyu Road, Tianliao, Gongming, Shenzhen, China

### **4.2. Test Facility**

#### **CNAS-Lab Code: L1225**

Shenzhen Huatongwei International Inspection Co., Ltd. has been assessed and proved to be in compliance with CNAS-CL01 Accreditation Criteria for Testing and Calibration Laboratories (identical to ISO/IEC17025: 2005 General Requirements) for the Competence of Testing and Calibration Laboratories.

#### **A2LA-Lab Cert. No.: 3902.01**

Shenzhen Huatongwei International Inspection Co., Ltd. EMC Laboratory has been accredited by A2LA for technical competence in the field of electrical testing, and proved to be in compliance with ISO/IEC 17025: 2005 General Requirements for the Competence of Testing and Calibration Laboratories and any additional program requirements in the identified field of testing.

#### **FCC-Registration No.: 762235**

Shenzhen Huatongwei International Inspection Co., Ltd. EMC Laboratory has been registered and fully described in a report filed with the FCC (Federal Communications Commission). The acceptance letter from the FCC is maintained in our files.

#### **IC-Registration No.:5377B-1**

Two 3m Alternate Test Site of Shenzhen Huatongwei International Inspection Co., Ltd. has been registered by Certification and Engineering Bureau of Industry Canada for the performance of radiated measurements with Registration No.: 5377B-1.

#### **ACA**

Shenzhen Huatongwei International Inspection Co., Ltd. EMC Laboratory can also perform testing for the Australian C-Tick mark as a result of our A2LA accreditation.

### 4.3. Environmental conditions

During the measurement the environmental conditions were within the listed ranges:

Temperature:	15~35°C
Relative Humidity:	30~60 %
Air Pressure:	950~1050mba

### 4.4. Statement of the measurement uncertainty

The data and results referenced in this document are true and accurate. The reader is cautioned that there may be errors in calibration limits of the equipment and facilities. The measurement uncertainty was calculated for all measurements listed in this test report according to TR-100028-01 "Electromagnetic compatibility and Radio spectrum Matters (ERM); Uncertainties in the measurement of mobile radio equipment characteristics; Part 1" and TR-100028-02 "Electromagnetic compatibility and Radio spectrum Matters (ERM); Uncertainties in the measurement of mobile radio equipment characteristics; Part 2" and is documented in the Shenzhen Huatongwei International Inspection Co., Ltd. quality system according to ISO/IEC 17025. Furthermore, component and process variability of devices similar to that tested may result in additional deviation. The manufacturer has the sole responsibility of continued compliance of the device.

Here after the best measurement capability for Shenzhen Huatongwei International Inspection Co., Ltd. is reported:

Test Items	Measurement Uncertainty	Notes
Transmitter power conducted	0.57 dB	(1)
Transmitter power Radiated	2.20 dB	(1)
Conducted spurious emissions 9kHz~40GHz	1.60 dB	(1)
Radiated spurious emissions 9kHz~40GHz	2.20 dB	(1)
Conducted Emissions 9kHz~30MHz	3.39 dB	(1)
Radiated Emissions 30~1000MHz	4.24 dB	(1)
Radiated Emissions 1~18GHz	5.16 dB	(1)
Radiated Emissions 18~40GHz	5.54 dB	(1)
Occupied Bandwidth	-----	(1)

(1) This uncertainty represents an expanded uncertainty expressed at approximately the 95% confidence level using a coverage factor of k=1.96.



**4.5. Equipments Used during the Test**

Conducted Emissions						
Item	Test Equipment	Manufacturer	Model No.	Serial No.	Last Cal. (mm-dd-yy)	Next Cal. (mm-dd-yy)
1	EMI Test Receiver	R&S	ESCI	101247	11/11/2017	11/10/2018
2	Artificial Mains	SCHWARZBECK	NNLK 8121	573	11/11/2017	11/10/2018
3	Pulse Limiter	R&S	ESH3-Z2	101488	11/11/2017	11/10/2018
4	Test Software	R&S	ES-K1	N/A	N/A	N/A
5	RF Connection Cable	HUBER+SUHNER	EF400	N/A	11/21/2017	11/20/2018
6	Single Balanced Telecom Pair ISN	FCC	FCC-TLISN-T2-02	20371	11/11/2017	11/10/2018
7	Two Balanced Telecom Pairs ISN	FCC	FCC-TLISN-T4-02	20373	11/11/2017	11/10/2018
8	Four Balanced Telecom Pairs ISN	FCC	FCC-TLISN-T8-02	20375	11/11/2017	11/10/2018
9	V-Network	R&S	ESH3-Z6	100211	11/11/2017	11/10/2018
10	V-Network	R&S	ESH3-Z6	100210	11/11/2017	11/10/2018
11	2-Line V-Network	R&S	ESH3-Z5	100049	11/11/2017	11/10/2018

Radiated Emissions						
Item	Test Equipment	Manufacturer	Model No.	Serial No.	Last Cal. (mm-dd-yy)	Next Cal. (mm-dd-yy)
1	EMI Test Receiver	R&S	ESCI	101247	11/11/2017	11/10/2018
2	Loop Antenna	R&S	HFH2-Z2	100020	11/20/2017	11/19/2018
3	Ultra-Broadband Antenna	SCHWARZBECK	VULB9163	538	4/5/2017	4/4/2018
4	Horn Antenna	SCHWARZBECK	9120D	1011	3/27/2017	3/26/2018
5	Horn Antenna	SCHWARZBECK	BBHA9170	25841	3/27/2017	3/26/2018
6	Preamplifier	SCHWARZBECK	BBV 9743	9743-0022	10/18/2017	10/17/2018
7	Broadband Preamplifier	SCHWARZBECK	BBV 9718	9718-248	10/18/2017	10/17/2018
8	High pass filter	Compliance Direction systems	BSU-6	34202	11/11/2017	11/10/2018
9	Turntable	MATURO	TT2.0	/	N/A	N/A
10	Antenna Mast	MATURO	TAM-4.0-P	/	N/A	N/A
11	EMI Test Software	R&S	ESK1	N/A	N/A	N/A
12	EMI Test Software	Audix	E3	N/A	N/A	N/A

13	RF Connection Cable	HUBER+SUHNER	3m 3GHz S	N/A	11/21/2017	11/20/2018
14	RF Connection Cable	HUBER+SUHNER	3m 3GHz RG	N/A	11/21/2017	11/20/2018
15	RF Connection Cable	HUBER+SUHNER	6m 18GHz S	N/A	11/21/2017	11/20/2018

RF Conducted Method						
Item	Test Equipment	Manufacturer	Model No.	Serial No.	Last Cal. (mm-dd-yy)	Next Cal. (mm-dd-yy)
1	Spectrum Analyzer	R&S	FSV40	100048	11/11/2017	11/10/2018
2	OSP	R&S	OSP120	101317	N/A	N/A
3	OSP	R&S	OSP-B157	100890	N/A	N/A
4	Signal generator	R&S	SMB100A	177956	11/11/2017	11/10/2018
5	Vector signal generator	R&S	SMBV100A	260790	7/20/2017	7/19/2018
6	EXA Signal Analyzer	Agilent	N9020A	184247	9/22/2017	9/21/2018
7	Power Meter	Agilent	U2021XA	178231	9/22/2017	9/21/2018
8	DAQ Device	Agilent	U2531A	132812	9/22/2017	9/21/2018

The Cal.Interval was one year.

## 5. TEST CONDITIONS AND RESULTS

### 5.1. Antenna requirement

#### Requirement

##### **FCC CFR Title 47 Part 15 Subpart C Section 15.203:**

An intentional radiator shall be designed to ensure that no antenna other than that furnished by the responsible party shall be used with the device. The use of a permanently attached antenna or of an antenna that uses a unique coupling to the intentional radiator, the manufacturer may design the unit so that a broken antenna can be replaced by the user, but the use of a standard antenna jack or electrical connector is prohibited.

##### **FCC CFR Title 47 Part 15 Subpart C Section 15.247(c) (1)(i):**

(i) Systems operating in the 2400~2483.5 MHz band that is used exclusively for fixed. Point-to-point operations may employ transmitting antennas with directional gain greater than 6 dBi provided the maximum conducted output power of the intentional radiator is reduced by 1 dB for every 3 dB that the directional gain of the antenna exceeds 6 dBi.

#### Test Result:

**Passed**       **Not Applicable**

The directional gain of the antenna less than 6 dBi, please refer to the below antenna photo.

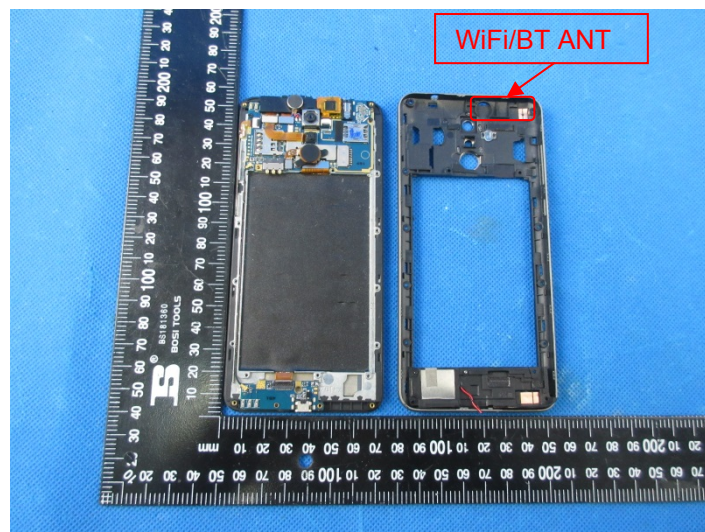

## 5.2. Conducted Emissions (AC Main)

### LIMIT

FCC CFR Title 47 Part 15 Subpart C Section 15.207

Frequency range (MHz)	Limit (dBuV)	
	Quasi-peak	Average
0.15-0.5	66 to 56*	56 to 46*
0.5-5	56	46
5-30	60	50

\* Decreases with the logarithm of the frequency.

### TEST CONFIGURATION

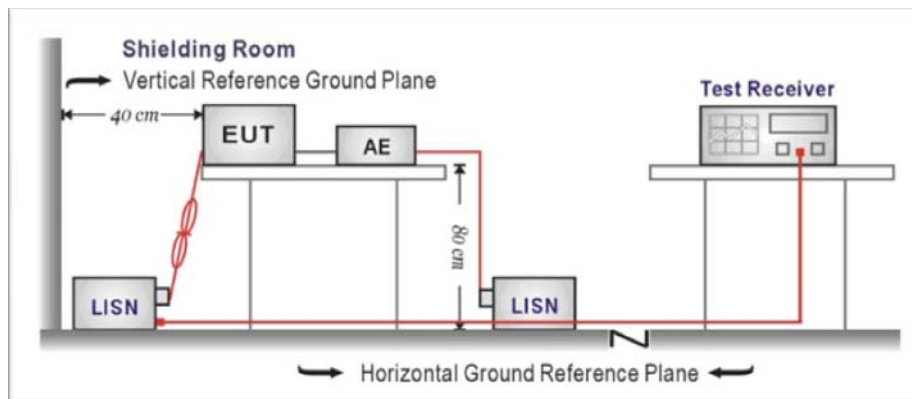

### TEST PROCEDURE

1. The EUT was setup according to ANSI C63.10:2013 requirements.
2. The EUT was placed on a platform of nominal size, 1 m by 1.5 m, raised 80 cm above the conducting ground plane. The vertical conducting plane was located 40 cm to the rear of the EUT. All other surfaces of EUT were at least 80 cm from any other grounded conducting surface.
3. The EUT and simulators are connected to the main power through a line impedances stabilization network (LISN). The LISN provides a 50 ohm /50uH coupling impedance for the measuring equipment.
4. The peripheral devices are also connected to the main power through a LISN. (Please refer to the block diagram of the test setup and photographs)
5. Each current-carrying conductor of the EUT power cord, except the ground (safety) conductor, was individually connected through a LISN to the input power source.
6. The excess length of the power cord between the EUT and the LISN receptacle were folded back and forth at the center of the lead to form a bundle not exceeding 40 cm in length.
7. Conducted emissions were investigated over the frequency range from 0.15MHz to 30MHz using a receiver bandwidth of 9 kHz.
8. During the above scans, the emissions were maximized by cable manipulation.

### TEST RESULTS

Passed       Not Applicable

Note:

- 1) Transd= Cable lose + Pulse Limiter Factor + Artificial Mains Factor
- 2) Margin= Limit - Level

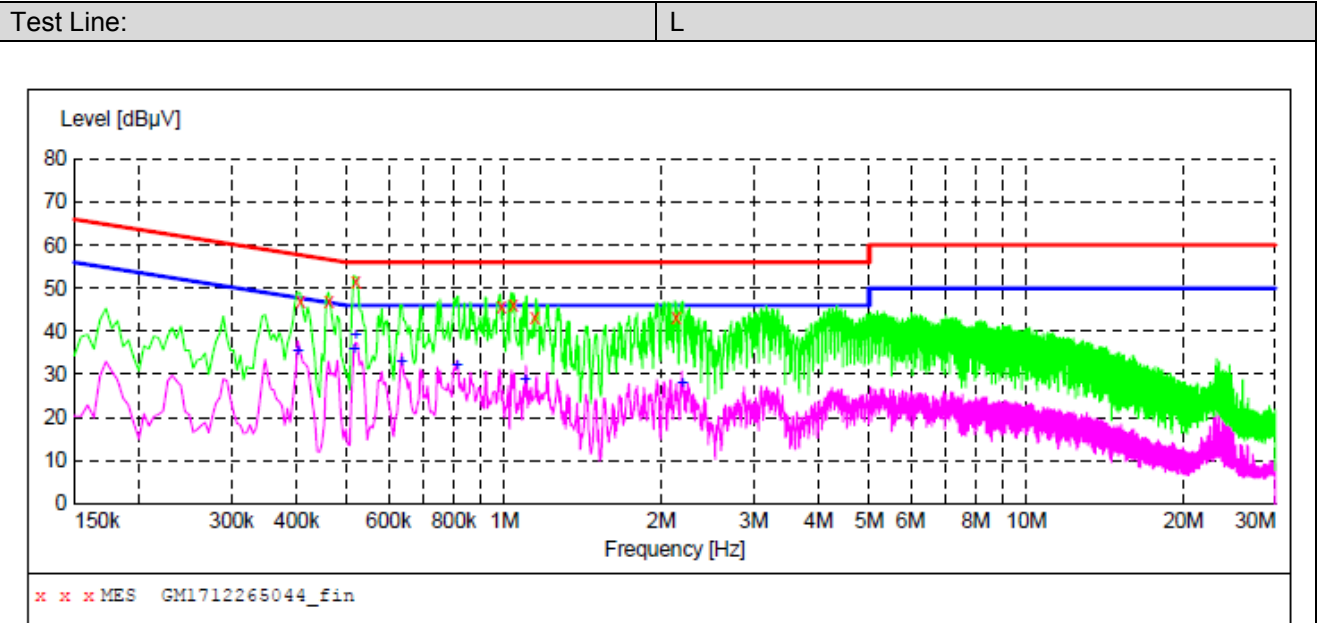

**MEASUREMENT RESULT: "GM1712265044\_fin"**

26/12/2017 13:51

Frequency MHz	Level dBµV	Transd dB	Limit dBµV	Margin dB	Detector	Line	PE
0.406500	46.90	9.9	58	10.8	QP	L1	GND
0.460500	47.10	9.9	57	9.6	QP	L1	GND
0.519000	51.40	10.0	56	4.6	QP	L1	GND
0.987000	45.90	10.1	56	10.1	QP	L1	GND
1.041000	46.30	10.1	56	9.7	QP	L1	GND
1.144500	43.10	10.1	56	12.9	QP	L1	GND
2.130000	43.20	10.1	56	12.8	QP	L1	GND

**MEASUREMENT RESULT: "GM1712265044\_fin2"**

26/12/2017 13:51

Frequency MHz	Level dBµV	Transd dB	Limit dBµV	Margin dB	Detector	Line	PE
0.402000	35.30	9.9	48	12.5	AV	L1	GND
0.514500	35.80	10.0	46	10.2	AV	L1	GND
0.519000	39.10	10.0	46	6.9	AV	L1	GND
0.636000	32.70	10.0	46	13.3	AV	L1	GND
0.811500	32.00	10.0	46	14.0	AV	L1	GND
1.095000	28.80	10.1	46	17.2	AV	L1	GND
2.193000	27.70	10.1	46	18.3	AV	L1	GND

Test Line: N

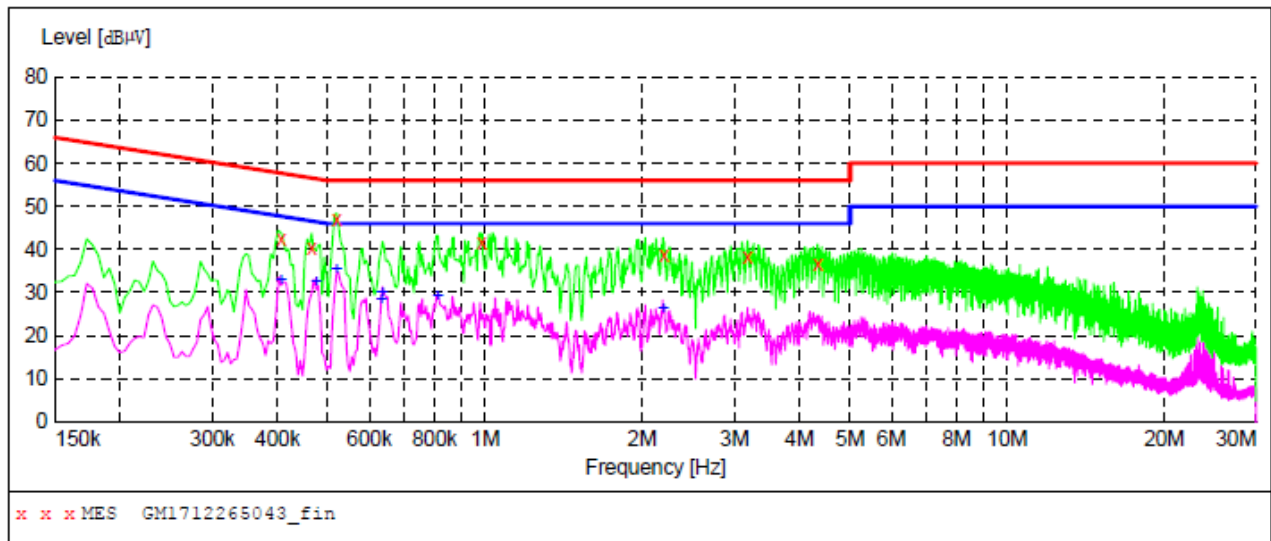

**MEASUREMENT RESULT: "GM1712265043\_fin"**

26/12/2017 13:48

Frequency MHz	Level dBµV	Transd dB	Limit dBµV	Margin dB	Detector	Line	PE
0.406500	42.40	9.9	58	15.3	QP	N	GND
0.465000	40.30	9.9	57	16.3	QP	N	GND
0.519000	47.10	10.0	56	8.9	QP	N	GND
0.982500	41.50	10.1	56	14.5	QP	N	GND
2.197500	38.80	10.1	56	17.2	QP	N	GND
3.178500	38.30	10.1	56	17.7	QP	N	GND
4.335000	36.60	10.2	56	19.4	QP	N	GND

**MEASUREMENT RESULT: "GM1712265043\_fin2"**

26/12/2017 13:48

Frequency MHz	Level dBµV	Transd dB	Limit dBµV	Margin dB	Detector	Line	PE
0.406500	32.80	9.9	48	14.9	AV	N	GND
0.474000	32.30	9.9	46	14.1	AV	N	GND
0.519000	35.20	10.0	46	10.8	AV	N	GND
0.631500	28.20	10.0	46	17.8	AV	N	GND
0.636000	30.10	10.0	46	15.9	AV	N	GND
0.811500	29.10	10.0	46	16.9	AV	N	GND
2.193000	26.40	10.1	46	19.6	AV	N	GND

### 5.3. Conducted Peak Output Power

#### LIMIT

FCC CFR Title 47 Part 15 Subpart C Section 15.247 (b)(1): For frequency hopping systems operating in the 2400-2483.5 MHz band employing at least 75 non-overlapping hopping channels, and all frequency hopping systems in the 5725-5850 MHz band: 1 watt. For all other frequency hopping systems in the 2400-2483.5 MHz band: 0.125 watts.

#### TEST CONFIGURATION

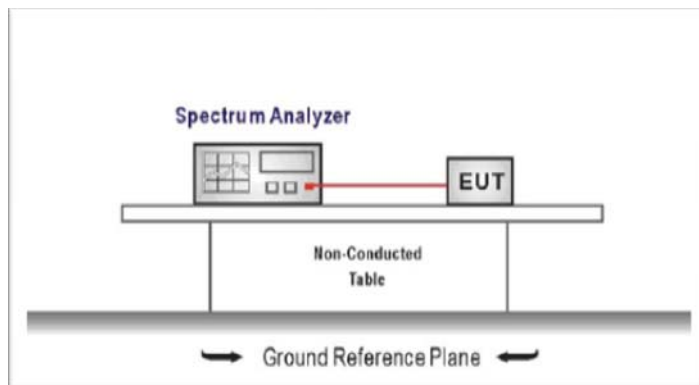

#### TEST PROCEDURE

1. The transmitter output was connected to the spectrum analyzer through an attenuator, the pathloss was compensated to the results for each measurement.
2. Set to the maximum power setting and enable the EUT transmit continuously
3. Use the following spectrum analyzer settings:  
Span = approximately 5 times the 20 dB bandwidth, centered on a hopping channel  
RBW  $\geq$  the 20 dB bandwidth of the emission being measured, VBW  $\geq$  RBW  
Sweep = auto, Detector function = peak, Trace = max hold
4. Measure and record the results in the test report.

#### TEST MODE:

Please refer to the clause 3.3



#### TEST RESULTS



Passed       Not Applicable

Modulation type	Channel	Output power (dBm)	Limit (dBm)	Result
GFSK	00	4.01	$\leq 30.00$	Pass
	39	4.30		
	78	3.73		
$\pi/4$ DQPSK	00	3.97	$\leq 21.00$	Pass
	39	4.21		
	78	3.66		
8DPSK	00	4.08	$\leq 21.00$	Pass
	39	4.35		
	78	3.83		

Modulation Type:		GFSK	
CH00		<p>Agilent Spectrum Analyzer - Sweep SA          Center Freq 2.40200000 GHz          #Avg Type: RMS          AvgHold: 500/500          Ref Offset 0.5 dB          Ref 20.00 dBm          Mkr1 2.402 025 GHz          4.012 dBm          Center 2.402000 GHz          #Res BW 1.0 MHz          #VBW 3.0 MHz          Span 5.000 MHz          Sweep 1.000 ms (1001 pts)</p>	<p>Frequency</p> <p>Auto Tune</p> <p>Center Freq 2.40200000 GHz</p> <p>Start Freq 2.399500000 GHz</p> <p>Stop Freq 2.404500000 GHz</p> <p>CF Step 500.000 kHz Auto Man</p> <p>Freq Offset 0 Hz</p>
CH39		<p>Agilent Spectrum Analyzer - Sweep SA          Center Freq 2.44100000 GHz          #Avg Type: RMS          AvgHold: 500/500          Ref Offset 0.5 dB          Ref 20.00 dBm          Mkr1 2.441 085 GHz          4.298 dBm          Center 2.441000 GHz          #Res BW 1.0 MHz          #VBW 3.0 MHz          Span 5.000 MHz          Sweep 1.000 ms (1001 pts)</p>	<p>Frequency</p> <p>Auto Tune</p> <p>Center Freq 2.441000000 GHz</p> <p>Start Freq 2.438500000 GHz</p> <p>Stop Freq 2.443500000 GHz</p> <p>CF Step 500.000 kHz Auto Man</p> <p>Freq Offset 0 Hz</p>
CH78		<p>Agilent Spectrum Analyzer - Sweep SA          Center Freq 2.48000000 GHz          #Avg Type: RMS          AvgHold: 500/500          Ref Offset 0.5 dB          Ref 20.00 dBm          Mkr1 2.480 075 GHz          3.733 dBm          Center 2.480000 GHz          #Res BW 1.0 MHz          #VBW 3.0 MHz          Span 5.000 MHz          Sweep 1.000 ms (1001 pts)</p>	<p>Frequency</p> <p>Auto Tune</p> <p>Center Freq 2.480000000 GHz</p> <p>Start Freq 2.477500000 GHz</p> <p>Stop Freq 2.482500000 GHz</p> <p>CF Step 500.000 kHz Auto Man</p> <p>Freq Offset 0 Hz</p>



Modulation Type:		$\pi/4$ DQPSK
CH00		<p>Agilent Spectrum Analyzer - Sweep SA</p> <p>Center Freq 2.40200000 GHz</p> <p>Ref Offset 0.5 dB Ref 20.00 dBm</p> <p>Mkr1 2.402090 GHz 3.973 dBm</p> <p>Center 2.402000 GHz #Res BW 2.0 MHz</p> <p>#VBW 6.0 MHz</p> <p>Span 5.000 MHz Sweep 1.000 ms (1001 pts)</p>
CH39		<p>Agilent Spectrum Analyzer - Sweep SA</p> <p>Center Freq 2.44100000 GHz</p> <p>Ref Offset 0.5 dB Ref 20.00 dBm</p> <p>Mkr1 2.440855 GHz 4.206 dBm</p> <p>Center 2.441000 GHz #Res BW 2.0 MHz</p> <p>#VBW 6.0 MHz</p> <p>Span 5.000 MHz Sweep 1.000 ms (1001 pts)</p>
CH78		<p>Agilent Spectrum Analyzer - Sweep SA</p> <p>Center Freq 2.48000000 GHz</p> <p>Ref Offset 0.5 dB Ref 20.00 dBm</p> <p>Mkr1 2.480105 GHz 3.657 dBm</p> <p>Center 2.480000 GHz #Res BW 2.0 MHz</p> <p>#VBW 6.0 MHz</p> <p>Span 5.000 MHz Sweep 1.000 ms (1001 pts)</p>

Modulation Type:		8DPSK
CH00		 <p>Agilent Spectrum Analyzer - Sweep SA          Center Freq 2.40200000 GHz          Ref Offset 0.5 dB          Ref 20.00 dBm          Mkr1 2.401960 GHz          4.080 dBm          #Avg Type: RMS          AvgHold: 500/500          #Res BW 2.0 MHz          #VBW 6.0 MHz          Span 5.000 MHz          Sweep 1.000 ms (1001 pts)</p>
CH39		 <p>Agilent Spectrum Analyzer - Sweep SA          Center Freq 2.44100000 GHz          Ref Offset 0.5 dB          Ref 20.00 dBm          Mkr1 2.440965 GHz          4.353 dBm          #Avg Type: RMS          AvgHold: 500/500          #Res BW 2.0 MHz          #VBW 6.0 MHz          Span 5.000 MHz          Sweep 1.000 ms (1001 pts)</p>
CH78		 <p>Agilent Spectrum Analyzer - Sweep SA          Center Freq 2.48000000 GHz          Ref Offset 0.5 dB          Ref 20.00 dBm          Mkr1 2.479965 GHz          3.827 dBm          #Avg Type: RMS          AvgHold: 500/500          #Res BW 2.0 MHz          #VBW 6.0 MHz          Span 5.000 MHz          Sweep 1.000 ms (1001 pts)</p>

## 5.4. 20 dB Bandwidth

### LIMIT

N/A

### TEST CONFIGURATION

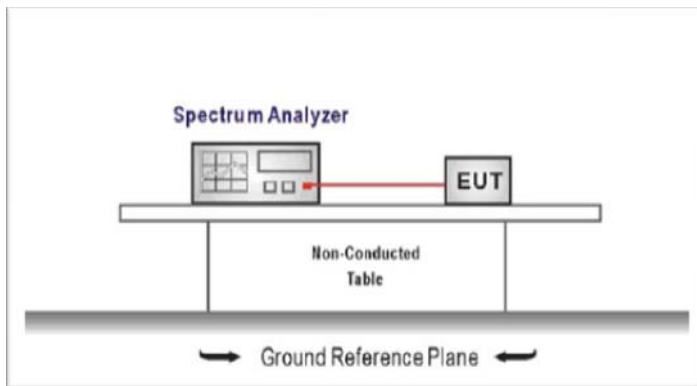

### TEST PROCEDURE

1. The transmitter output was connected to the spectrum analyzer through an attenuator, the path loss was compensated to the results for each measurement.
2. Set to the maximum power setting and enable the EUT transmit continuously
3. Use the following spectrum analyzer settings:  
Span = approximately 2 to 3 times the 20 dB bandwidth, centered on a hopping channel  
RBW  $\geq$  1% of the 20 dB bandwidth, VBW  $\geq$  RBW  
Sweep = auto, Detector function = peak, Trace = max hold
4. Measure and record the results in the test report.

### TEST MODE:

Please refer to the clause 3.3

### TEST RESULTS

 Passed       Not Applicable

Modulation type	Channel	20 dB Bandwidth (MHz)	Limit (MHz)	Result
GFSK	00	0.93	-	Pass
	39	0.93		
	78	0.93		
$\pi/4$ DQPSK	00	1.29	-	Pass
	39	1.29		
	78	1.29		
8DPSK	00	1.29	-	Pass
	39	1.30		
	78	1.29		

Modulation Type:		GFSK	
<p>CH00</p>		<p>Agilent Spectrum Analyzer - Occupied BW          Center Freq 2.402000000 GHz          Ref Offset 0.5 dB          Ref 20.00 dBm          Mkr1 2.402045 GHz          -1.5972 dBm          Center 2.402 GHz          #Res BW 10 kHz          #VBW 30 kHz          Span 2.5 MHz          Sweep 23.93 ms          Occupied Bandwidth 880.66 kHz          Total Power 10.5 dBm          Transmit Freq Error -13.153 kHz          OBW Power 99.00 %          x dB Bandwidth 925.7 kHz          x dB -20.00 dB</p>	<p>Frequency          Center Freq          2.402000000 GHz          CF Step          250.000 kHz          Freq Offset          0 Hz</p>
<p>CH39</p>		<p>Agilent Spectrum Analyzer - Occupied BW          Center Freq 2.441000000 GHz          Ref Offset 0.5 dB          Ref 20.00 dBm          Mkr1 2.441045 GHz          -1.3492 dBm          Center 2.441 GHz          #Res BW 10 kHz          #VBW 30 kHz          Span 2.5 MHz          Sweep 23.93 ms          Occupied Bandwidth 880.25 kHz          Total Power 10.8 dBm          Transmit Freq Error -12.801 kHz          OBW Power 99.00 %          x dB Bandwidth 925.9 kHz          x dB -20.00 dB</p>	<p>Frequency          Center Freq          2.441000000 GHz          CF Step          250.000 kHz          Freq Offset          0 Hz</p>
<p>CH78</p>		<p>Agilent Spectrum Analyzer - Occupied BW          Center Freq 2.480000000 GHz          Ref Offset 0.5 dB          Ref 20.00 dBm          Mkr1 2.4800475 GHz          -1.8546 dBm          Center 2.48 GHz          #Res BW 10 kHz          #VBW 30 kHz          Span 2.5 MHz          Sweep 23.93 ms          Occupied Bandwidth 878.97 kHz          Total Power 10.2 dBm          Transmit Freq Error -12.927 kHz          OBW Power 99.00 %          x dB Bandwidth 925.5 kHz          x dB -20.00 dB</p>	<p>Frequency          Center Freq          2.480000000 GHz          CF Step          250.000 kHz          Freq Offset          0 Hz</p>

Modulation Type:		$\pi/4$ DQPSK
CH00	<p>Agilent Spectrum Analyzer - Occupied BW                  Center Freq 2.402000000 GHz                  Ref Offset 0.5 dB                  Ref 20.00 dBm                  Mkr1 2.402155 GHz                  0.19363 dBm                  Center 2.402 GHz                  #Res BW 30 kHz                  #VBW 100 kHz                  Span 2.5 MHz                  Sweep 2.667 ms                  Occupied Bandwidth 1.1719 MHz                  Total Power 9.87 dBm                  Transmit Freq Error -10.107 kHz                  OBW Power 99.00 %                  x dB Bandwidth 1.287 MHz                  x dB -20.00 dB</p>	<p>Frequency</p> <p>Center Freq 2.402000000 GHz</p> <p>CF Step 250.000 kHz</p> <p>Freq Offset 0 Hz</p>
CH39	<p>Agilent Spectrum Analyzer - Occupied BW                  Center Freq 2.441000000 GHz                  Ref Offset 0.5 dB                  Ref 20.00 dBm                  Mkr1 2.441155 GHz                  0.50525 dBm                  Center 2.441 GHz                  #Res BW 30 kHz                  #VBW 100 kHz                  Span 2.5 MHz                  Sweep 2.667 ms                  Occupied Bandwidth 1.1695 MHz                  Total Power 10.2 dBm                  Transmit Freq Error -9.802 kHz                  OBW Power 99.00 %                  x dB Bandwidth 1.287 MHz                  x dB -20.00 dB</p>	<p>Frequency</p> <p>Center Freq 2.441000000 GHz</p> <p>CF Step 250.000 kHz</p> <p>Freq Offset 0 Hz</p>
CH78	<p>Agilent Spectrum Analyzer - Occupied BW                  Center Freq 2.480000000 GHz                  Ref Offset 0.5 dB                  Ref 20.00 dBm                  Mkr1 2.4801525 GHz                  -0.83274 dBm                  Center 2.48 GHz                  #Res BW 30 kHz                  #VBW 100 kHz                  Span 2.5 MHz                  Sweep 2.667 ms                  Occupied Bandwidth 1.1702 MHz                  Total Power 9.57 dBm                  Transmit Freq Error -9.497 kHz                  OBW Power 99.00 %                  x dB Bandwidth 1.293 MHz                  x dB -20.00 dB</p>	<p>Frequency</p> <p>Center Freq 2.480000000 GHz</p> <p>CF Step 250.000 kHz</p> <p>Freq Offset 0 Hz</p>

Modulation Type:		8DPSK	
CH00		<p>Agilent Spectrum Analyzer - Occupied BW</p> <p>Center Freq 2.402000000 GHz</p> <p>Ref Offset 0.5 dB Ref 20.00 dBm</p> <p>Mkr1 2.40216 GHz 0.48153 dBm</p> <p>Center 2.402 GHz</p> <p>Occupied Bandwidth 1.1770 MHz</p> <p>Total Power 9.92 dBm</p> <p>Transmit Freq Error -5.668 kHz</p> <p>x dB Bandwidth 1.292 MHz</p>	<p>Frequency</p> <p>Center Freq 2.402000000 GHz</p> <p>CF Step 250.000 kHz</p> <p>Freq Offset 0 Hz</p>
CH39		<p>Agilent Spectrum Analyzer - Occupied BW</p> <p>Center Freq 2.441000000 GHz</p> <p>Ref Offset 0.5 dB Ref 20.00 dBm</p> <p>Mkr1 2.44115 GHz -0.27273 dBm</p> <p>Center 2.441 GHz</p> <p>Occupied Bandwidth 1.1750 MHz</p> <p>Total Power 10.2 dBm</p> <p>Transmit Freq Error -5.929 kHz</p> <p>x dB Bandwidth 1.304 MHz</p>	<p>Frequency</p> <p>Center Freq 2.441000000 GHz</p> <p>CF Step 250.000 kHz</p> <p>Freq Offset 0 Hz</p>
CH78		<p>Agilent Spectrum Analyzer - Occupied BW</p> <p>Center Freq 2.480000000 GHz</p> <p>Ref Offset 0.5 dB Ref 20.00 dBm</p> <p>Mkr1 2.480155 GHz 0.70507 dBm</p> <p>Center 2.48 GHz</p> <p>Occupied Bandwidth 1.1715 MHz</p> <p>Total Power 9.77 dBm</p> <p>Transmit Freq Error -5.370 kHz</p> <p>x dB Bandwidth 1.285 MHz</p>	<p>Frequency</p> <p>Center Freq 2.480000000 GHz</p> <p>CF Step 250.000 kHz</p> <p>Freq Offset 0 Hz</p>



### 5.5. Carrier Frequencies Separation

#### LIMIT

FCC CFR Title 47 Part 15 Subpart C Section 15.247 (a)(1):Frequency hopping systems shall have hopping channel carrier frequencies separated by minimum of 25 kHz or the 2/3\*20 dB bandwidth of the hopping channel, whichever is greater.

#### TEST CONFIGURATION

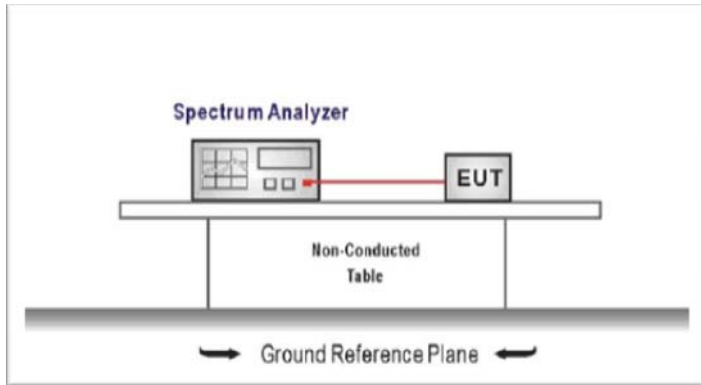

#### TEST PROCEDURE

1. The transmitter output was connected to the spectrum analyzer through an attenuator, the path loss was compensated to the results for each measurement.
2. Set to the maximum power setting and enable the EUT transmit continuously
3. Use the following spectrum analyzer settings:  
 Span = wide enough to capture the peaks of two adjacent channels  
 RBW ≥ 1% of the span, VBW ≥ RBW  
 Sweep = auto, Detector function = peak, Trace = max hold
4. Measure and record the results in the test report.

#### TEST MODE:

Please refer to the clause 3.3

#### TEST RESULTS

Passed       Not Applicable

Modulation type	Channel	Carrier Frequencies Separation (MHz)	Limit (MHz) *	Result
GFSK	39	1.00	≥0.93	Pass
π/4DQPSK	39	1.00	≥0.86	Pass
8DPSK	39	1.00	≥0.87	Pass

Note:

\*: GFSK limit = The maximum 20 dB Bandwidth for GFSK modulation on the section 5.4.

π/4DQPSK limit = 2/3 \* The maximum 20 dB Bandwidth for π/4DQPSK modulation on the section 5.4.

8DPSK limit = 2/3 \* The maximum 20 dB Bandwidth for 8DPSK modulation on the section 5.4

<p>GFSK</p>	 <p>Agilent Spectrum Analyzer - Swept SA</p> <p>Center Freq 2.441500000 GHz #Avg Type: RMS AvgHold: 100/100</p> <p>Ref Offset 0.5 dB Ref 20.00 dBm <math>\Delta</math>Mkr1 999 kHz -0.180 dB</p> <p>Start 2.440000 GHz #Res BW 30 kHz #VBW 100 kHz Stop 2.443000 GHz Sweep 3.200 ms (1001 pts)</p> <p>Frequency</p> <ul style="list-style-type: none"> <li>Auto Tune</li> <li>Center Freq 2.441500000 GHz</li> <li>Start Freq 2.440000000 GHz</li> <li>Stop Freq 2.443000000 GHz</li> <li>CF Step 300.000 kHz Man</li> <li>Freq Offset 0 Hz</li> </ul>	
<p><math>\pi</math>/4DQPSK</p>	 <p>Agilent Spectrum Analyzer - Swept SA</p> <p>Center Freq 2.441500000 GHz #Avg Type: RMS AvgHold: 100/100</p> <p>Ref Offset 0.5 dB Ref 20.00 dBm <math>\Delta</math>Mkr1 999 kHz 0.033 dB</p> <p>Start 2.440000 GHz #Res BW 30 kHz #VBW 100 kHz Stop 2.443000 GHz Sweep 3.200 ms (1001 pts)</p> <p>Frequency</p> <ul style="list-style-type: none"> <li>Auto Tune</li> <li>Center Freq 2.441500000 GHz</li> <li>Start Freq 2.440000000 GHz</li> <li>Stop Freq 2.443000000 GHz</li> <li>CF Step 300.000 kHz Man</li> <li>Freq Offset 0 Hz</li> </ul>	
<p>8DPSK</p>	 <p>Agilent Spectrum Analyzer - Swept SA</p> <p>Center Freq 2.441500000 GHz #Avg Type: RMS AvgHold: 100/100</p> <p>Ref Offset 0.5 dB Ref 20.00 dBm <math>\Delta</math>Mkr1 996 kHz 0.282 dB</p> <p>Start 2.440000 GHz #Res BW 30 kHz #VBW 100 kHz Stop 2.443000 GHz Sweep 3.200 ms (1001 pts)</p> <p>Frequency</p> <ul style="list-style-type: none"> <li>Auto Tune</li> <li>Center Freq 2.441500000 GHz</li> <li>Start Freq 2.440000000 GHz</li> <li>Stop Freq 2.443000000 GHz</li> <li>CF Step 300.000 kHz Man</li> <li>Freq Offset 0 Hz</li> </ul>	



## 5.6. Hopping Channel Number

### LIMIT

FCC CFR Title 47 Part 15 Subpart C Section 15.247 (a)(1):Frequency hopping systems in the 2400–2483.5 MHz band shall use at least **15** channels.

### TEST CONFIGURATION

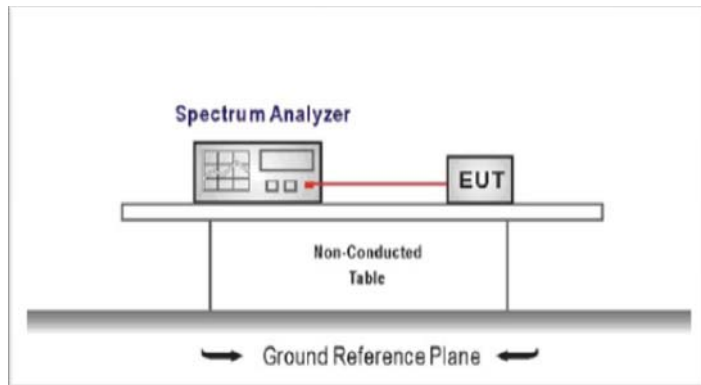

### TEST PROCEDURE

1. The transmitter output was connected to the spectrum analyzer through an attenuator, the path loss was compensated to the results for each measurement.
2. Set to the maximum power setting and enable the EUT transmit continuously
3. Use the following spectrum analyzer settings:  
 Span = the frequency band of operation  
 RBW  $\geq$  1% of the span, VBW  $\geq$  RBW  
 Sweep = auto, Detector function = peak, Trace = max hold
4. Measure and record the results in the test report.

### TEST MODE:

Please refer to the clause 3.3

### TEST RESULTS

**Passed**       **Not Applicable**

Modulation type	Channel number	Limit	Result
GFSK	79	$\geq 15.00$	Pass
$\pi/4$ DQPSK	79		
8DPSK	79		

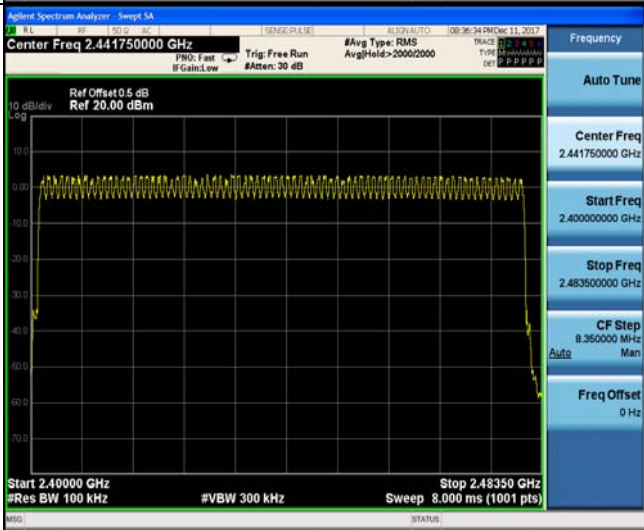
<p>GFSK</p>		
<p><math>\pi/4</math>DQPSK</p>		
<p>8DPSK</p>		

## 5.7. Dwell Time

### LIMIT

FCC CFR Title 47 Part 15 Subpart C Section 15.247 (a)(1): The average time of occupancy on any channel shall not be greater than 0.4 seconds within a pe-riod of 0.4 seconds multiplied by the number of hopping channels employed.

### TEST CONFIGURATION

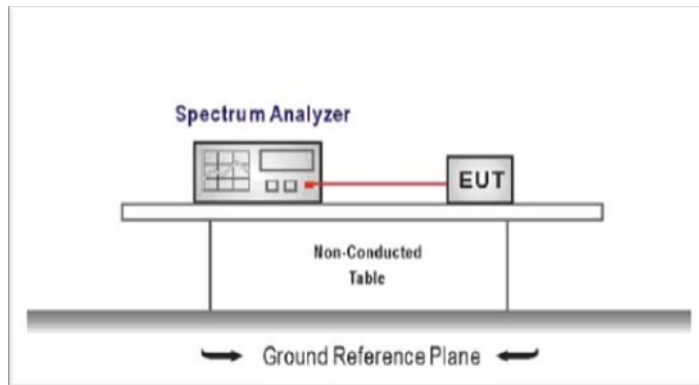

### TEST PROCEDURE

1. The transmitter output was connected to the spectrum analyzer through an attenuator, the path loss was compensated to the results for each measurement.
2. Set to the maximum power setting and enable the EUT transmit continuously
3. Use the following spectrum analyzer settings:  
Span = zero span, centered on a hopping channel, RBW= 1 MHz, VBW  $\geq$  RBW  
Sweep = as necessary to capture the entire dwell time per hopping channel,  
Detector function = peak, Trace = max hold
4. Measure and record the results in the test report.

### TEST MODE:

Please refer to the clause 3.3

### TEST RESULTS

Passed       Not Applicable

Modulation type	Channel	Burst Width [ms/hop/ch]	Total Hops[hop*ch]	Dwell time (Second)	Limit (Second)	Result
GFSK	DH1	0.37	314.00	0.12	$\leq 0.40$	Pass
	DH3	1.63	159.00	0.26		
	DH5	2.87	100.00	0.29		
$\pi/4$ DQPSK	2DH1	0.38	314.00	0.12	$\leq 0.40$	Pass
	2DH3	1.63	158.00	0.26		
	2DH5	2.88	106.00	0.31		
8DPSK	3DH1	0.38	318.00	0.12	$\leq 0.40$	Pass
	3DH3	1.62	160.00	0.26		
	3DH5	2.88	94.00	0.27		

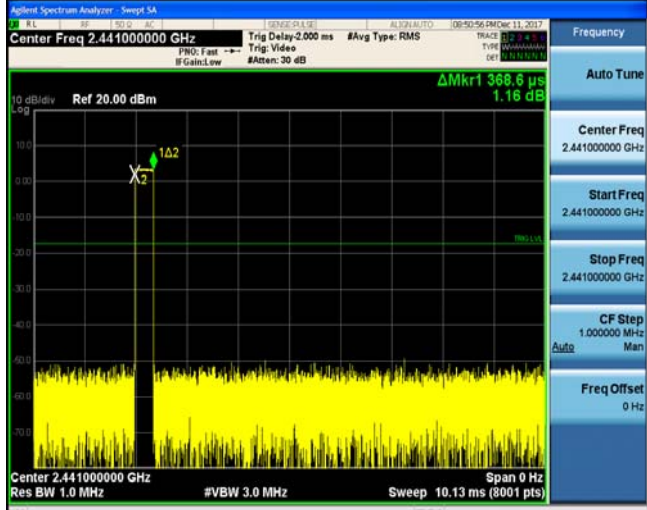
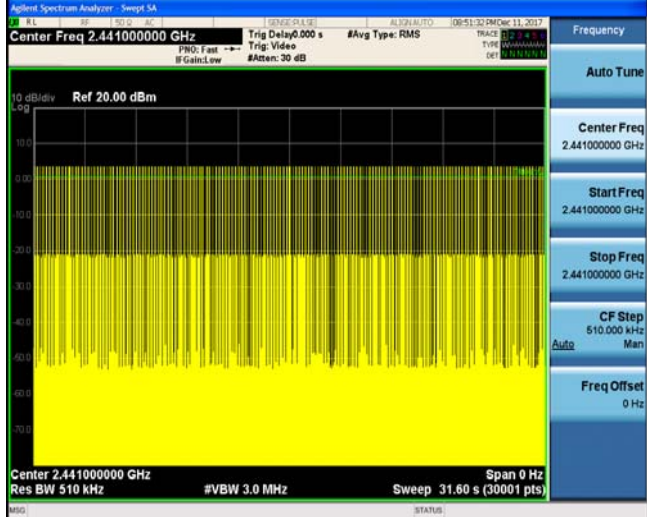
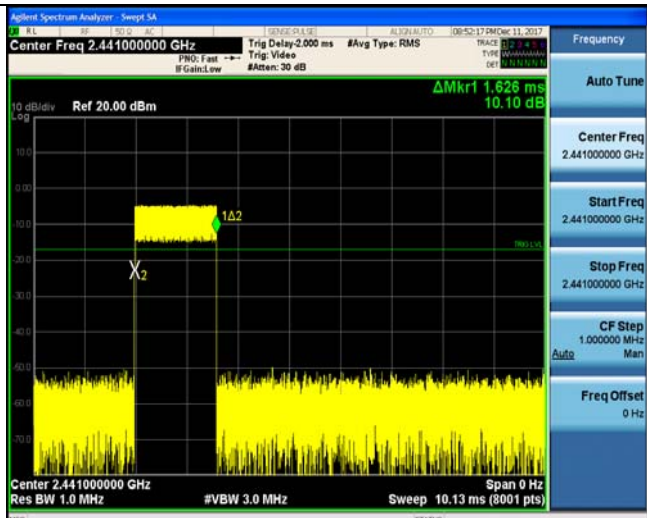
Modulation Type:		GFSK	
DH1		<p>Agilent Spectrum Analyzer - Swept SA</p> <p>Center Freq 2.441000000 GHz</p> <p>Trig Delay: 2.000 ms</p> <p>#Avg Type: RMS</p> <p>Ref 20.00 dBm</p> <p>ΔMkr1 368.6 μs</p> <p>1.16 dB</p> <p>Center 2.441000000 GHz</p> <p>Res BW 1.0 MHz</p> <p>#VBW 3.0 MHz</p> <p>Sweep 10.13 ms (8001 pts)</p>	<p>Frequency</p> <p>Auto Tune</p> <p>Center Freq 2.441000000 GHz</p> <p>Start Freq 2.441000000 GHz</p> <p>Stop Freq 2.441000000 GHz</p> <p>CF Step 1.000000 MHz</p> <p>Freq Offset 0 Hz</p>
		<p>Agilent Spectrum Analyzer - Swept SA</p> <p>Center Freq 2.441000000 GHz</p> <p>Trig Delay: 0.000 s</p> <p>#Avg Type: RMS</p> <p>Ref 20.00 dBm</p> <p>ΔMkr1 510.000 kHz</p> <p>Center 2.441000000 GHz</p> <p>Res BW 510 kHz</p> <p>#VBW 3.0 MHz</p> <p>Sweep 31.60 s (30001 pts)</p>	<p>Frequency</p> <p>Auto Tune</p> <p>Center Freq 2.441000000 GHz</p> <p>Start Freq 2.441000000 GHz</p> <p>Stop Freq 2.441000000 GHz</p> <p>CF Step 510.000 kHz</p> <p>Freq Offset 0 Hz</p>
DH3		<p>Agilent Spectrum Analyzer - Swept SA</p> <p>Center Freq 2.441000000 GHz</p> <p>Trig Delay: 2.000 ms</p> <p>#Avg Type: RMS</p> <p>Ref 20.00 dBm</p> <p>ΔMkr1 1.626 ms</p> <p>10.10 dB</p> <p>Center 2.441000000 GHz</p> <p>Res BW 1.0 MHz</p> <p>#VBW 3.0 MHz</p> <p>Sweep 10.13 ms (8001 pts)</p>	<p>Frequency</p> <p>Auto Tune</p> <p>Center Freq 2.441000000 GHz</p> <p>Start Freq 2.441000000 GHz</p> <p>Stop Freq 2.441000000 GHz</p> <p>CF Step 1.000000 MHz</p> <p>Freq Offset 0 Hz</p>

DH5	

Modulation Type:		$\pi/4$ DQPSK
	2DH1	<p>Agilent Spectrum Analyzer - Sweep SA          Center Freq 2.441000000 GHz          Ref 20.00 dBm  <math>\Delta</math>Mkr1 376.2 <math>\mu</math>s          -8.66 dB          Center 2.441000000 GHz          Res BW 1.0 MHz          #VBW 3.0 MHz          Sweep 10.13 ms (8001 pts)</p>
	2DH2	<p>Agilent Spectrum Analyzer - Sweep SA          Center Freq 2.441000000 GHz          Ref 20.00 dBm  <math>\Delta</math>Mkr1 510.0 kHz          Center 2.441000000 GHz          Res BW 510 kHz          #VBW 3.0 MHz          Sweep 31.60 s (30001 pts)</p>
	2DH3	<p>Agilent Spectrum Analyzer - Sweep SA          Center Freq 2.441000000 GHz          Ref 20.00 dBm  <math>\Delta</math>Mkr1 1.629 ms          6.11 dB          Center 2.441000000 GHz          Res BW 1.0 MHz          #VBW 3.0 MHz          Sweep 10.13 ms (8001 pts)</p>

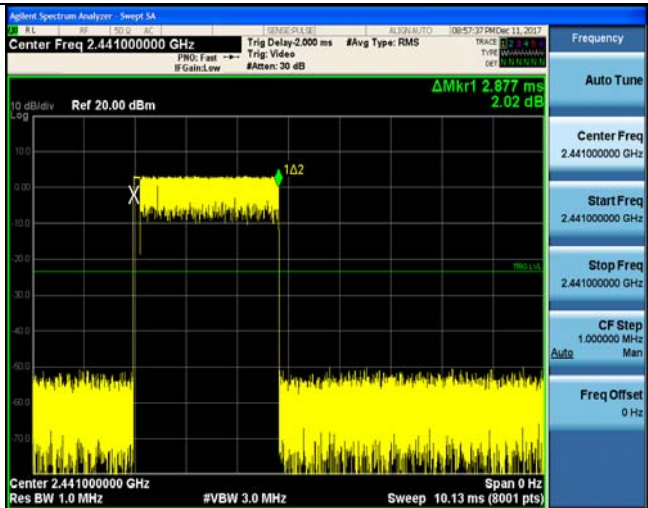
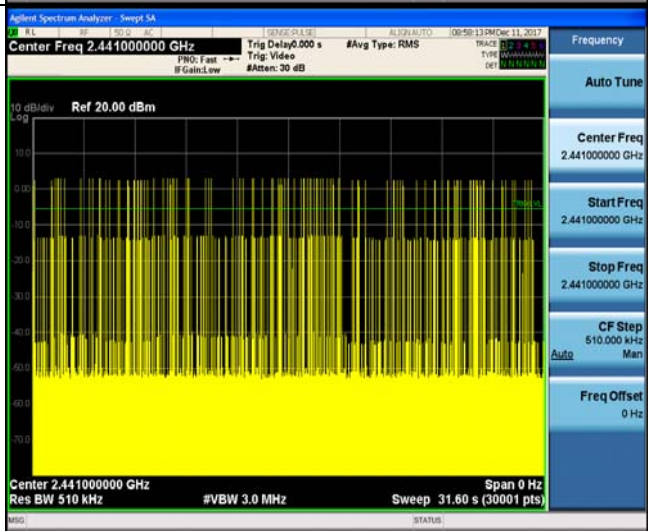

	 <p>Agilent Spectrum Analyzer - Swept SA</p> <p>Center Freq 2.441000000 GHz</p> <p>Trig Delay 0.000 s</p> <p>#Avg Type: RMS</p> <p>Ref 20.00 dBm</p> <p>10 dB/div</p> <p>Log</p> <p>Center 2.441000000 GHz</p> <p>Res BW 510 kHz</p> <p>#VBW 3.0 MHz</p> <p>Sweep 31.60 s (30001 pts)</p> <p>Span 0 Hz</p> <p>Frequency</p> <p>Auto Tune</p> <p>Center Freq 2.441000000 GHz</p> <p>Start Freq 2.441000000 GHz</p> <p>Stop Freq 2.441000000 GHz</p> <p>CF Step 510.000 kHz</p> <p>Freq Offset 0 Hz</p>
	 <p>Agilent Spectrum Analyzer - Swept SA</p> <p>Center Freq 2.441000000 GHz</p> <p>Trig Delay 2.000 ms</p> <p>#Avg Type: RMS</p> <p>Ref 20.00 dBm</p> <p>10 dB/div</p> <p>Log</p> <p>Center 2.441000000 GHz</p> <p>Res BW 1.0 MHz</p> <p>#VBW 3.0 MHz</p> <p>Sweep 10.13 ms (8001 pts)</p> <p>Span 0 Hz</p> <p>Frequency</p> <p>Auto Tune</p> <p>Center Freq 2.441000000 GHz</p> <p>Start Freq 2.441000000 GHz</p> <p>Stop Freq 2.441000000 GHz</p> <p>CF Step 1.000000 MHz</p> <p>Freq Offset 0 Hz</p> <p><math>\Delta</math>Mkr1 2.877 ms</p> <p>2.02 dB</p>
2DH5	 <p>Agilent Spectrum Analyzer - Swept SA</p> <p>Center Freq 2.441000000 GHz</p> <p>Trig Delay 0.000 s</p> <p>#Avg Type: RMS</p> <p>Ref 20.00 dBm</p> <p>10 dB/div</p> <p>Log</p> <p>Center 2.441000000 GHz</p> <p>Res BW 510 kHz</p> <p>#VBW 3.0 MHz</p> <p>Sweep 31.60 s (30001 pts)</p> <p>Span 0 Hz</p> <p>Frequency</p> <p>Auto Tune</p> <p>Center Freq 2.441000000 GHz</p> <p>Start Freq 2.441000000 GHz</p> <p>Stop Freq 2.441000000 GHz</p> <p>CF Step 510.000 kHz</p> <p>Freq Offset 0 Hz</p>

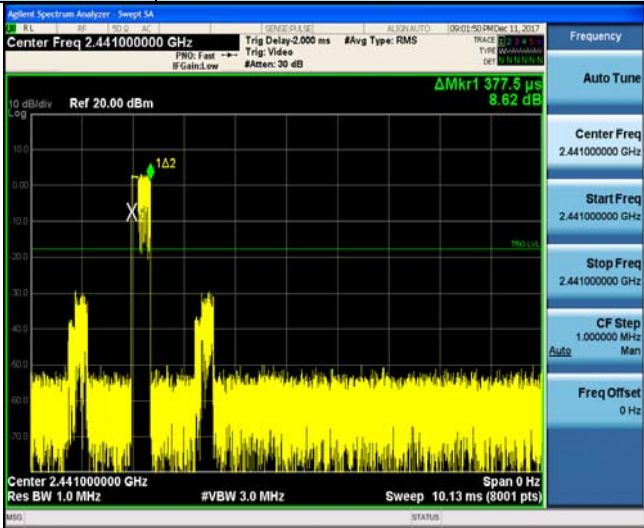
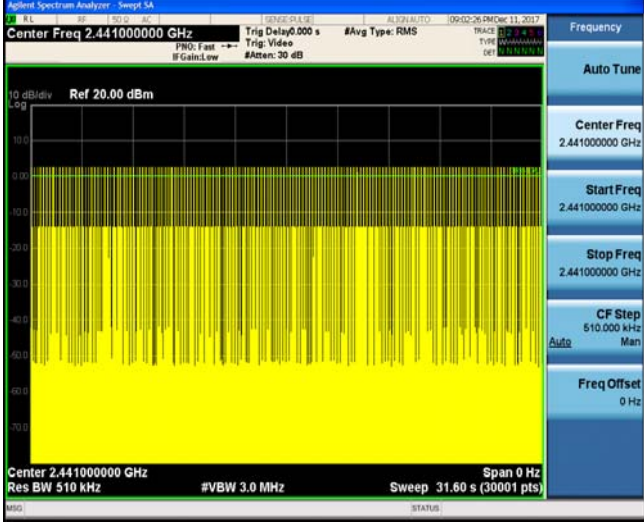
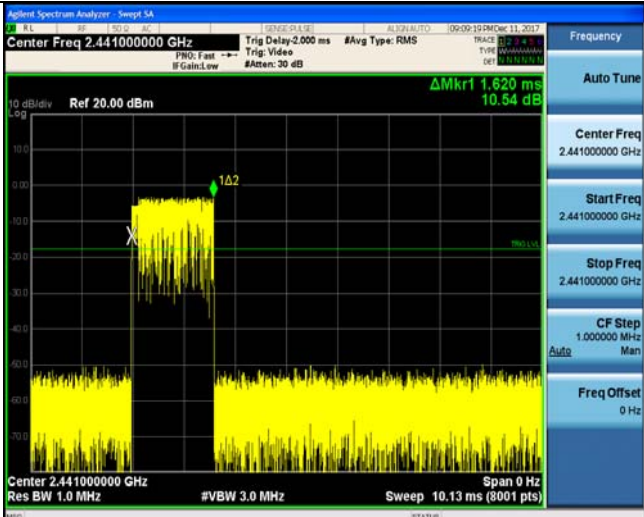
Modulation Type:		8DPSK
3DH1		<p>Agilent Spectrum Analyzer - Sweep SA</p> <p>Center Freq 2.441000000 GHz</p> <p>Trig Delay: 2.000 ms #Avg Type: RMS</p> <p>Ref 20.00 dBm</p> <p><math>\Delta Mk r1</math> 377.5 <math>\mu</math>s 8.62 dB</p> <p>Center 2.441000000 GHz Span 0 Hz Res BW 1.0 MHz #VBW 3.0 MHz Sweep 10.13 ms (8001 pts)</p>
		<p>Agilent Spectrum Analyzer - Sweep SA</p> <p>Center Freq 2.441000000 GHz</p> <p>Trig Delay: 0.000 s #Avg Type: RMS</p> <p>Ref 20.00 dBm</p> <p><math>\Delta Mk r1</math> 1.620 ms 10.54 dB</p> <p>Center 2.441000000 GHz Span 0 Hz Res BW 510 kHz #VBW 3.0 MHz Sweep 31.60 s (30001 pts)</p>
		<p>Agilent Spectrum Analyzer - Sweep SA</p> <p>Center Freq 2.441000000 GHz</p> <p>Trig Delay: 2.000 ms #Avg Type: RMS</p> <p>Ref 20.00 dBm</p> <p><math>\Delta Mk r1</math> 1.620 ms 10.54 dB</p> <p>Center 2.441000000 GHz Span 0 Hz Res BW 1.0 MHz #VBW 3.0 MHz Sweep 10.13 ms (8001 pts)</p>



3DH5	

### 5.8. Pseudorandom Frequency Hopping Sequence

#### LIMIT

FCC CFR Title 47 Part 15 Subpart C Section 15.247 (a)(1):Frequency hopping systems shall have hopping channel carrier frequencies separated by a minimum of 25 kHz or the 20 dB bandwidth of the hopping channel, whichever is greater. Alternatively, frequency hopping systems operating in the 2400–2483.5 MHz band may have hopping channel carrier frequencies that are separated by 25 kHz or two-thirds of the 20 dB bandwidth of the hopping channel, whichever is greater, provided the systems operate with an output power no greater than 125 mW. The system shall hop to channel frequencies that are selected at the system hopping rate from a pseudo randomly ordered list of hopping frequencies. Each frequency must be used equally on the average by each transmitter. The system receivers shall have input bandwidths that match the hopping channel bandwidths of their corresponding transmitters and shall shift frequencies in synchronization with the transmitted signals.

#### TEST RESULTS

The pseudorandom frequency hopping sequence may be generated in a nine-stage shift register whose 5<sup>th</sup> and 9<sup>th</sup> stage outputs are added in a modulo-two addition stage. And the result is fed back to the input of the first stage. The sequence begins with the first one of 9 consecutive ones, for example: the shift register is initialized with nine ones.

- Number of shift register stages: 9
- Length of pseudo-random sequence:  $2^9 - 1 = 511$  bits
- Longest sequence of zeros: 8 (non-inverted signal)

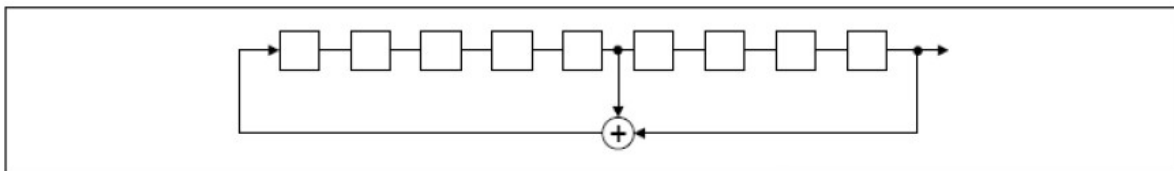

*Linear Feedback Shift Register for Generation of the PRBS sequence*

An example of pseudorandom frequency hopping sequence as follows:

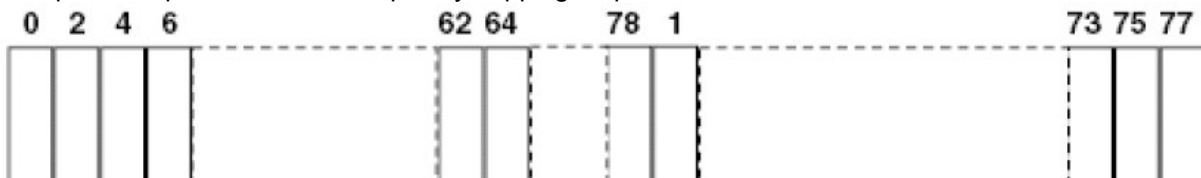

Each frequency used equally on the average by each transmitter. The system receiver has input bandwidths that match the hopping channel bandwidths of their corresponding transmitter and shift frequencies in synchronization with the transmitted signals.

## 5.9. Restricted band (radiated)

### LIMIT

#### **FCC CFR Title 47 Part 15 Subpart C Section 15.247 (d):**

In any 100 kHz bandwidth outside the frequency band in which the spread spectrum or digitally modulated intentional radiator is operating, Radiated Emissions which fall in the restricted bands, as defined in §15.205(a), must also comply with the Radiated Emissions limits specified in §15.209(a) (see §15.205(c)).

### TEST CONFIGURATION

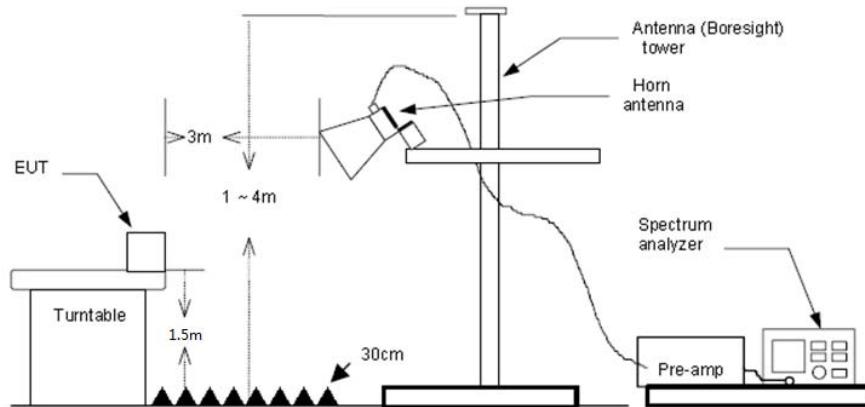

### TEST PROCEDURE

1. The EUT was setup and tested according to ANSI C63.10:2013 for compliance to FCC 47CFR 15.247 requirements.
2. The EUT is placed on a turn table which is 1.5 meter above ground. The turn table is rotated 360 degrees to determine the position of the maximum emission level.
3. The EUT was positioned such that the distance from antenna to the EUT was 3 meters.
4. The antenna is scanned from 1 meter to 4 meters to find out the maximum emission level. This is repeated for both horizontal and vertical polarization of the antenna. In order to find the maximum emission, all of the interface cables were manipulated according to ANSI C63.10:2013 on radiated measurement.
5. The receiver set as follow:  
 RBW=1 MHz, VBW=3 MHz Peak detector for Peak value  
 RBW=1 MHz, VBW=10 Hz Peak detector for Average value.

### TEST MODE:

Please refer to the clause 3.3

### TEST RESULTS

Passed       Not Applicable

#### Note:

- 1) Final level= Read level + Antenna Factor+ Cable Loss- Preamp Factor
- 2) Have pre-scan all modulation mode, found the GFSK modulation which it was worst case, so only the worst case's data on the test report.
- 3) The peak level is lower than average limit(54 dBuV/m), this data is the too weak instrument of signal is unable to test.

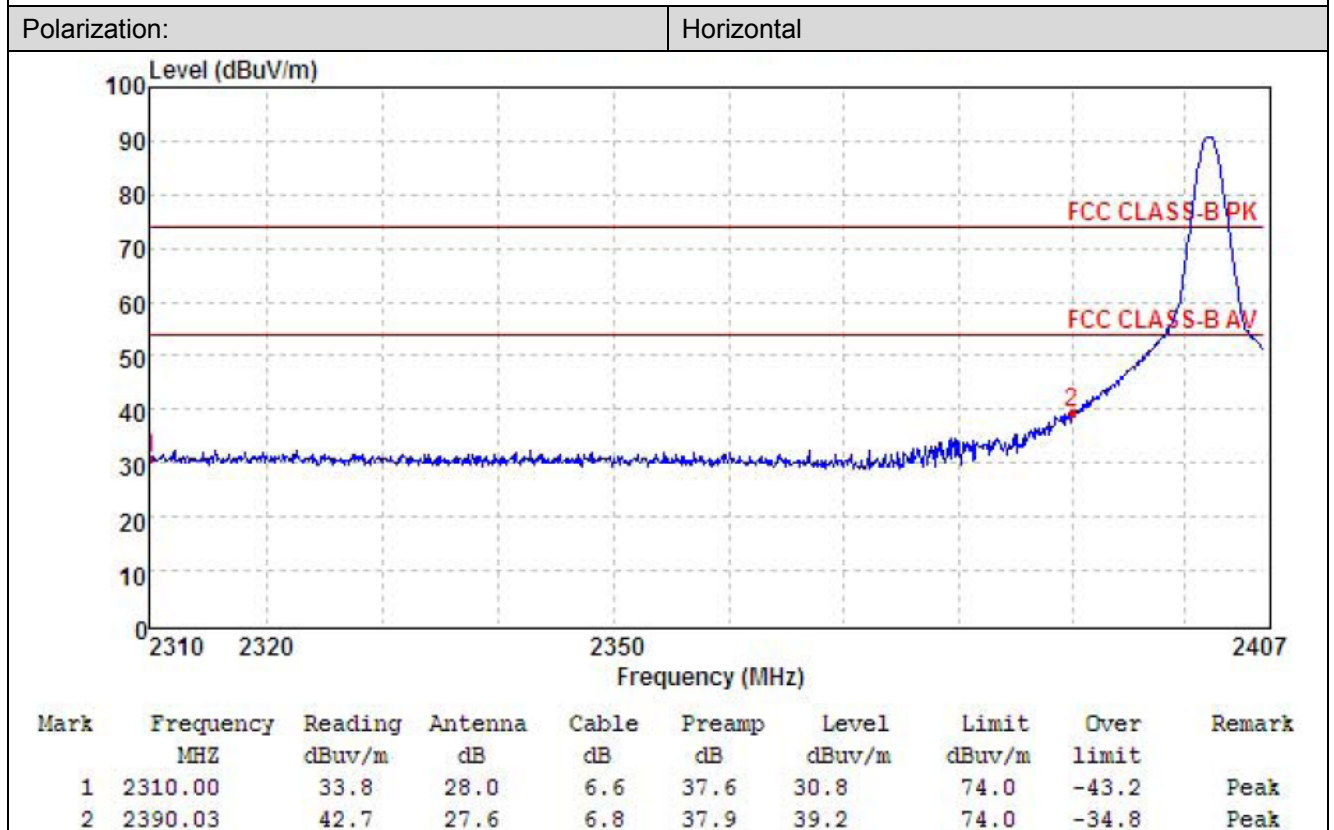
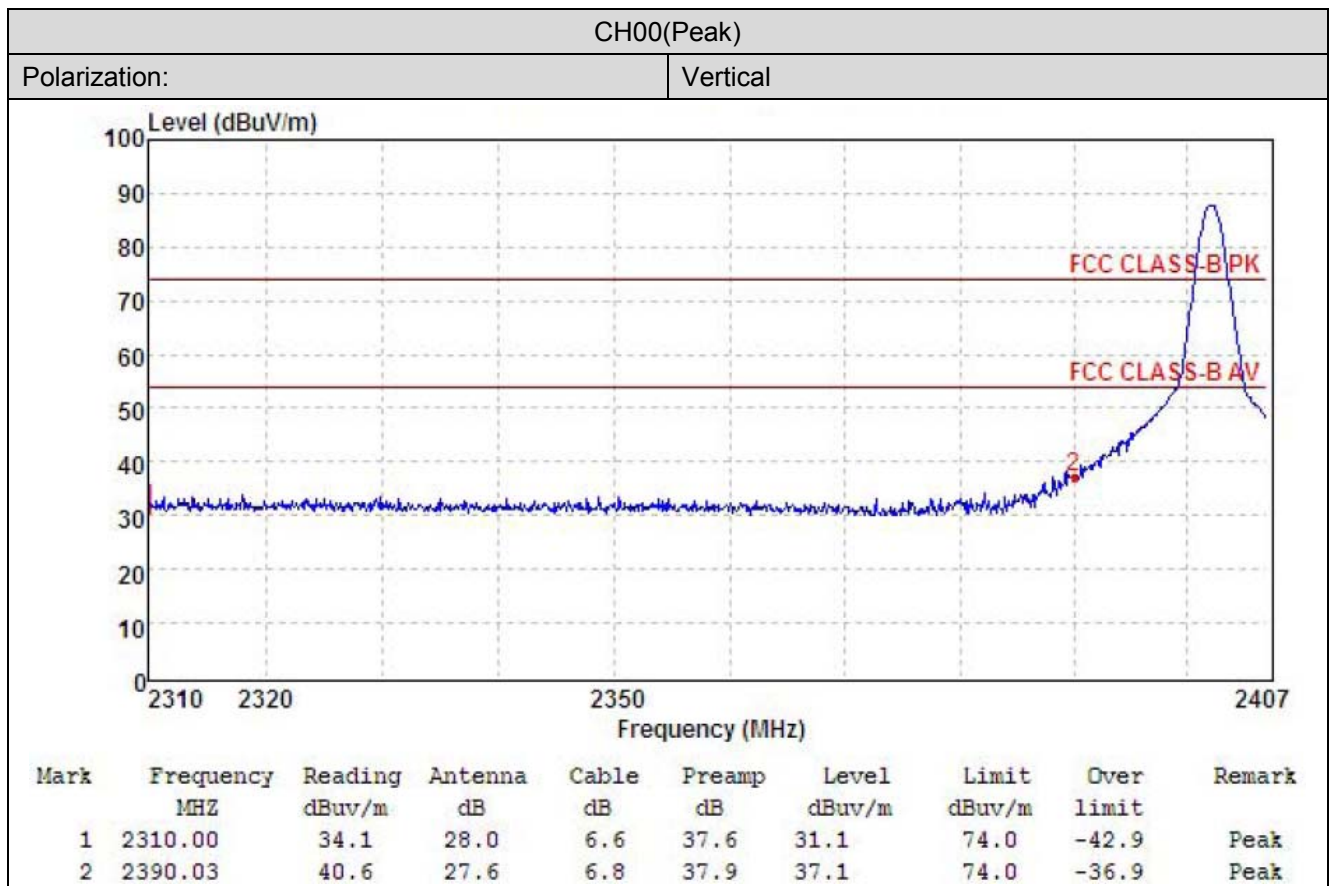

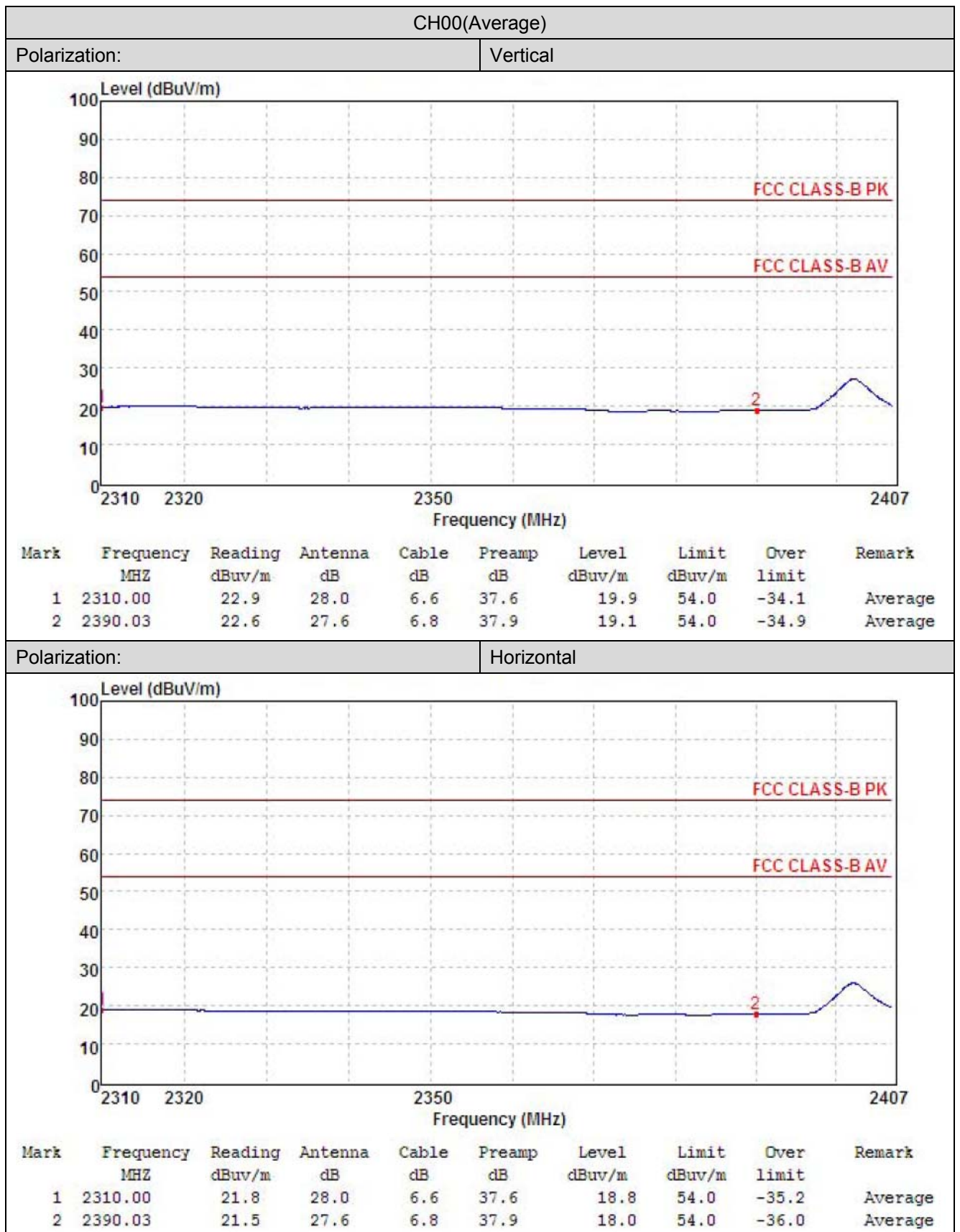



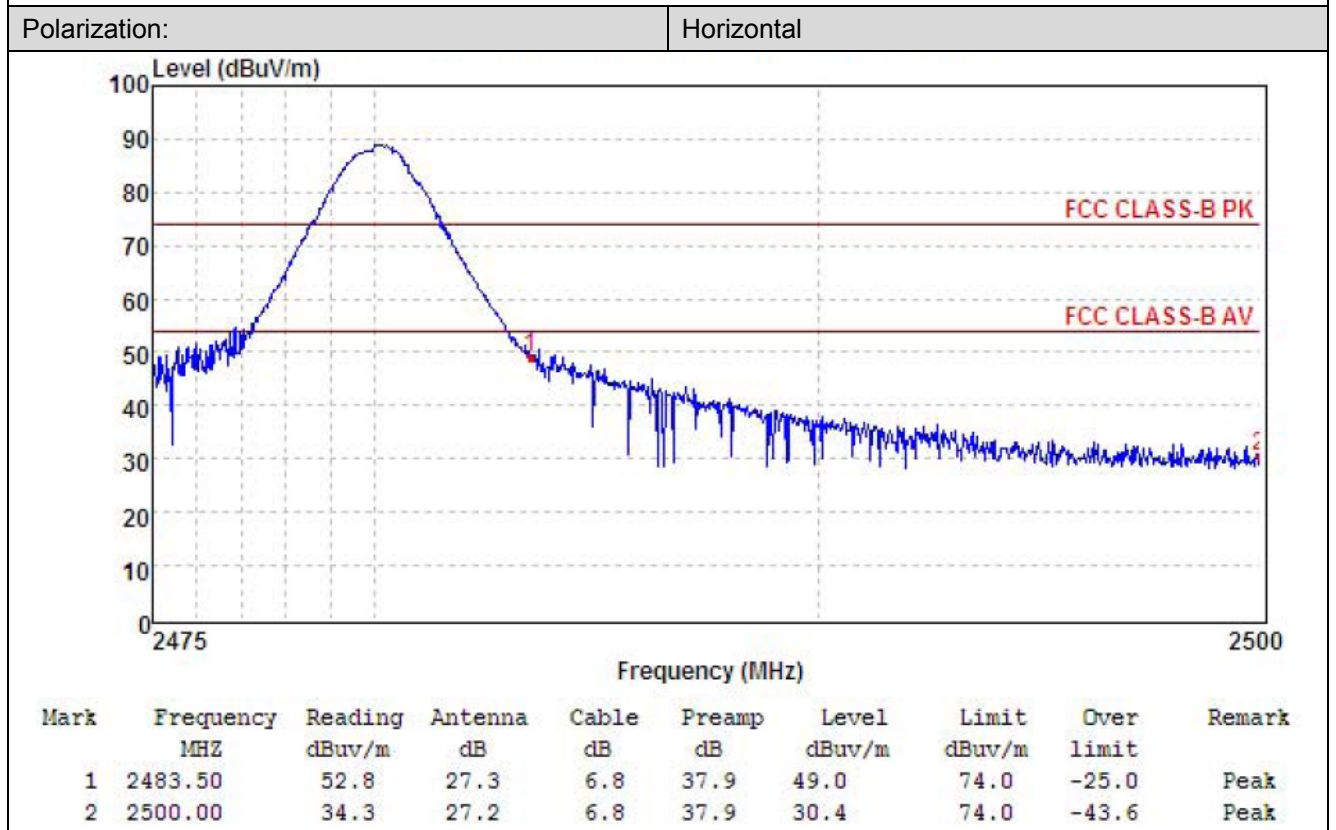
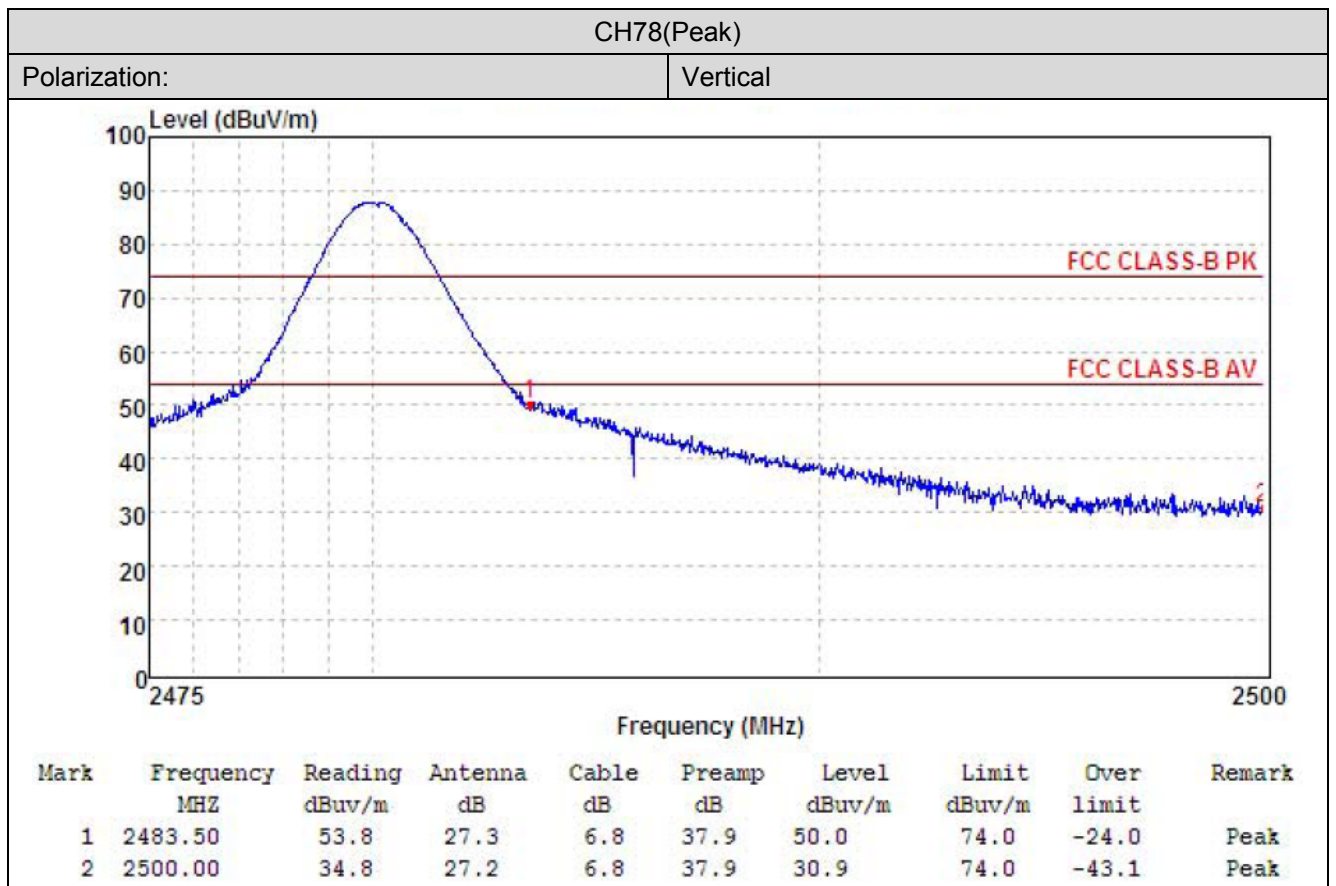

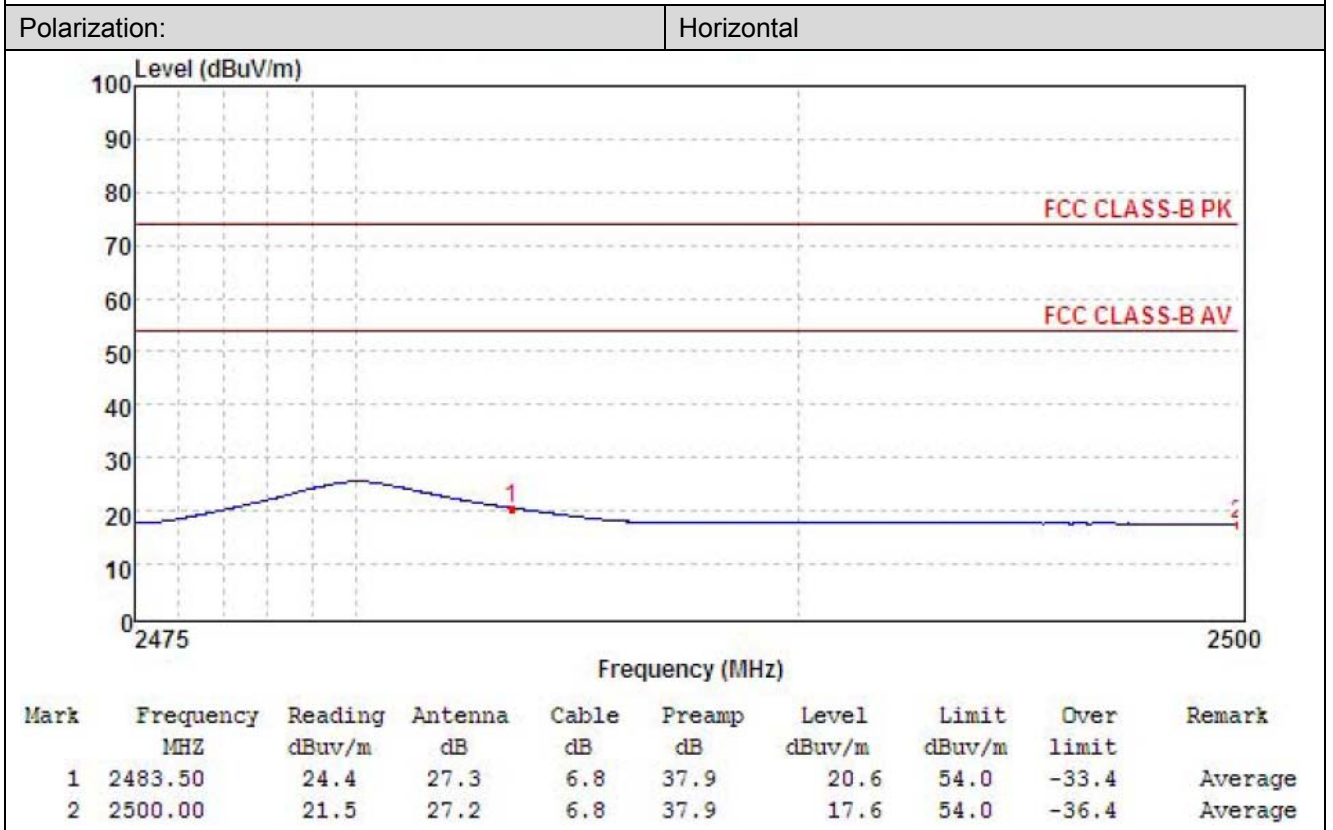
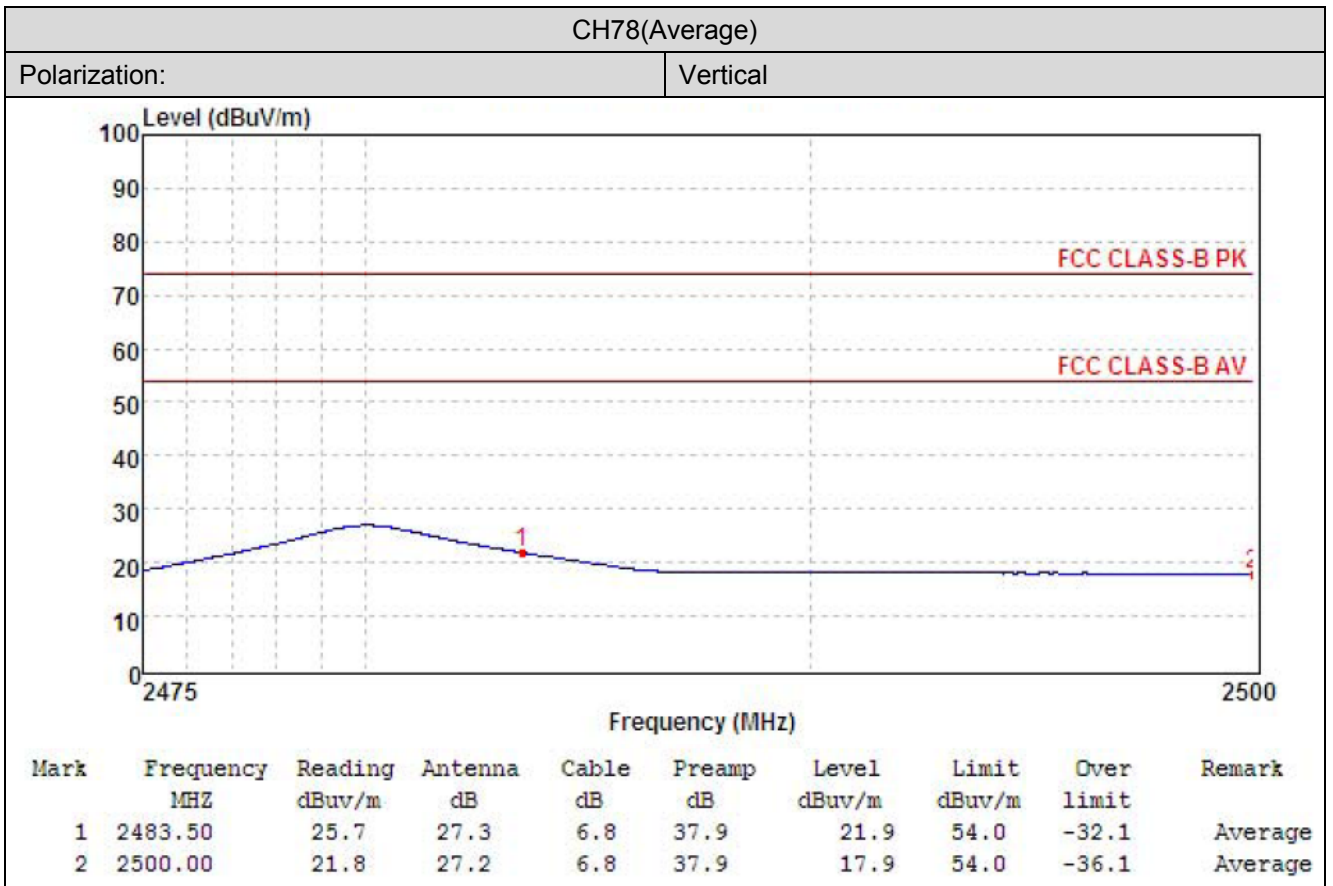

## 5.10. Band edge and Spurious Emissions (conducted)

### LIMIT

FCC CFR Title 47 Part 15 Subpart C Section 15.247 (d): In any 100 kHz bandwidth outside the frequency band in which the spread spectrum intentional radiator is operating, the radio frequency power that is produced by the intentional radiator shall be at least 20 dB below that in the 100 kHz bandwidth within the band that contains the highest level of the desired power, based on either an RF conducted or a radiated measurement.

### TEST CONFIGURATION

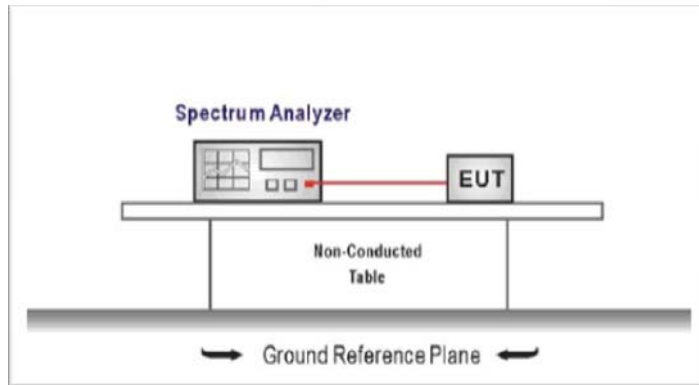

### TEST PROCEDURE

1. The transmitter output was connected to the spectrum analyzer through an attenuator, the path loss was compensated to the results for each measurement.
2. Set to the maximum power setting and enable the EUT transmit continuously
3. Use the following spectrum analyzer settings:  
RBW = 100 kHz, VBW  $\geq$  RBW  
Sweep = auto, Detector function = peak, Trace = max hold
4. Measure and record the results in the test report.

### TEST MODE:

Please refer to the clause 3.3

### TEST RESULTS

Passed       Not Applicable

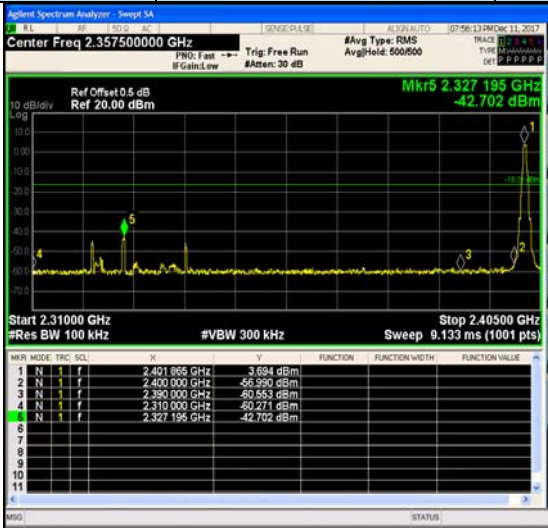
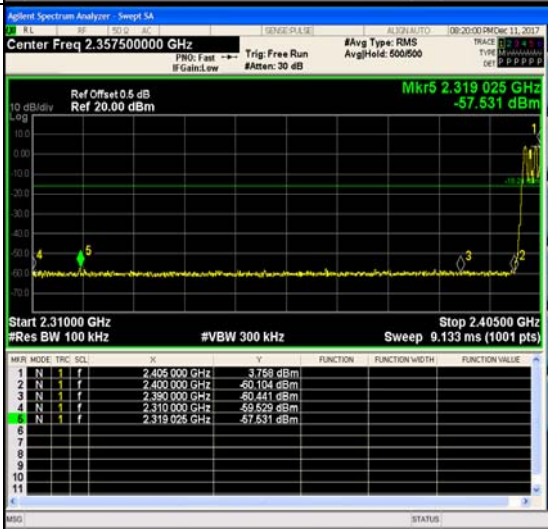
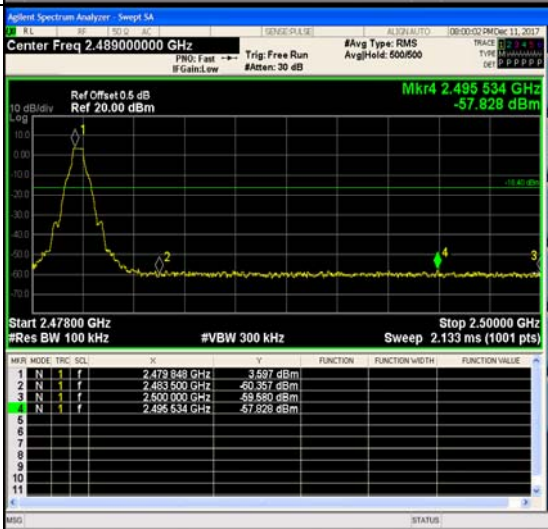

Test Item:	Band edge	Modulation type:	GFSK
<p>CH00 No hopping mode</p>			<p>Frequency</p> <p>Auto Tune</p> <p>Center Freq 2.357500000 GHz</p> <p>Start Freq 2.310000000 GHz</p> <p>Stop Freq 2.405000000 GHz</p> <p>CF Step 9.500000 MHz</p> <p>Freq Offset 0 Hz</p>
<p>CH00 Hopping mode</p>			<p>Frequency</p> <p>Auto Tune</p> <p>Center Freq 2.357500000 GHz</p> <p>Start Freq 2.310000000 GHz</p> <p>Stop Freq 2.405000000 GHz</p> <p>CF Step 9.500000 MHz</p> <p>Freq Offset 0 Hz</p>
<p>CH78 No hopping mode</p>			<p>Frequency</p> <p>Auto Tune</p> <p>Center Freq 2.489000000 GHz</p> <p>Start Freq 2.478000000 GHz</p> <p>Stop Freq 2.500000000 GHz</p> <p>CF Step 2.200000 MHz</p> <p>Freq Offset 0 Hz</p>

CH78  
Hopping mode

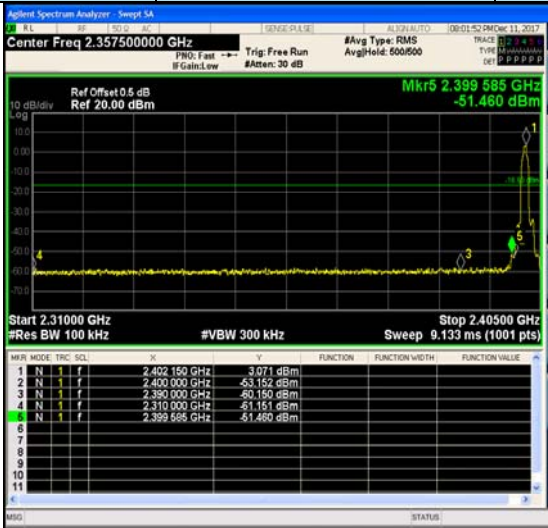

Test Item:	Band edge	Modulation type:	$\pi/4$ DQPSK
<p>CH00</p> <p>No hopping mode</p>			<p>Frequency</p> <p>Auto Tune</p> <p>Center Freq 2.357500000 GHz</p> <p>Start Freq 2.310000000 GHz</p> <p>Stop Freq 2.405000000 GHz</p> <p>CF Step 9.500000 MHz</p> <p>Freq Offset 0 Hz</p>
<p>CH00</p> <p>Hopping mode</p>			<p>Frequency</p> <p>Auto Tune</p> <p>Center Freq 2.357500000 GHz</p> <p>Start Freq 2.310000000 GHz</p> <p>Stop Freq 2.405000000 GHz</p> <p>CF Step 9.500000 MHz</p> <p>Freq Offset 0 Hz</p>
<p>CH78</p> <p>No hopping mode</p>			<p>Frequency</p> <p>Auto Tune</p> <p>Center Freq 2.489000000 GHz</p> <p>Start Freq 2.478000000 GHz</p> <p>Stop Freq 2.500000000 GHz</p> <p>CF Step 2.200000 MHz</p> <p>Freq Offset 0 Hz</p>

CH78  
Hopping mode





Test Item:	Band edge	Modulation type:	8DPSK
<p>CH00 No hopping mode</p>		<p>Center Freq 2.357500000 GHz</p> <p>Start Freq 2.310000000 GHz</p> <p>Stop Freq 2.405000000 GHz</p> <p>CF Step 9.500000 MHz</p> <p>Freq Offset 0 Hz</p>	<p>Frequency</p> <p>Auto Tune</p> <p>Center Freq 2.357500000 GHz</p> <p>Start Freq 2.310000000 GHz</p> <p>Stop Freq 2.405000000 GHz</p> <p>CF Step 9.500000 MHz</p> <p>Freq Offset 0 Hz</p>
<p>CH00 Hopping mode</p>		<p>Center Freq 2.357500000 GHz</p> <p>Start Freq 2.310000000 GHz</p> <p>Stop Freq 2.405000000 GHz</p> <p>CF Step 9.500000 MHz</p> <p>Freq Offset 0 Hz</p>	<p>Frequency</p> <p>Auto Tune</p> <p>Center Freq 2.357500000 GHz</p> <p>Start Freq 2.310000000 GHz</p> <p>Stop Freq 2.405000000 GHz</p> <p>CF Step 9.500000 MHz</p> <p>Freq Offset 0 Hz</p>
<p>CH78 No hopping mode</p>		<p>Center Freq 2.489000000 GHz</p> <p>Start Freq 2.478000000 GHz</p> <p>Stop Freq 2.500000000 GHz</p> <p>CF Step 2.200000 MHz</p> <p>Freq Offset 0 Hz</p>	<p>Frequency</p> <p>Auto Tune</p> <p>Center Freq 2.489000000 GHz</p> <p>Start Freq 2.478000000 GHz</p> <p>Stop Freq 2.500000000 GHz</p> <p>CF Step 2.200000 MHz</p> <p>Freq Offset 0 Hz</p>

CH78  
Hoppig mode



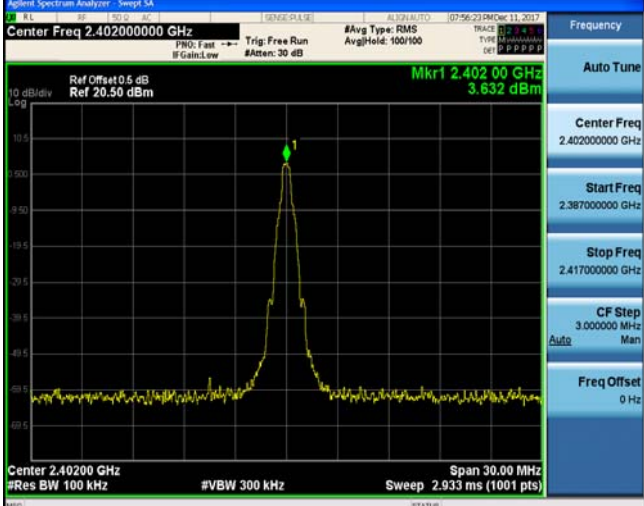
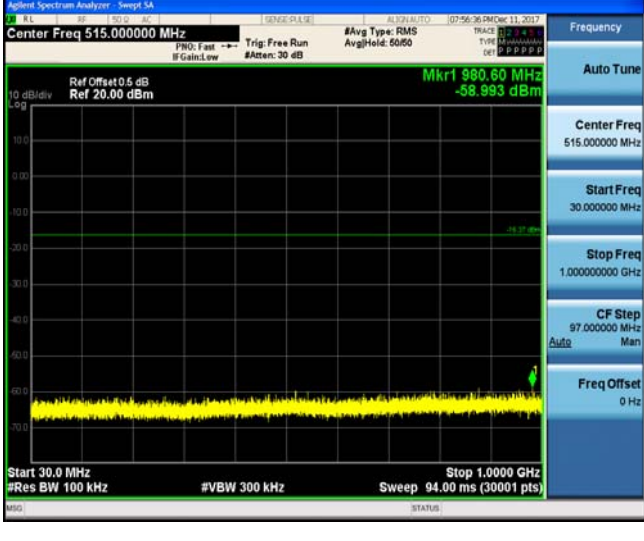

Test Item:	SE	Modulation type:	GFSK
reference level CH00			
CH00			
			



reference level CH39

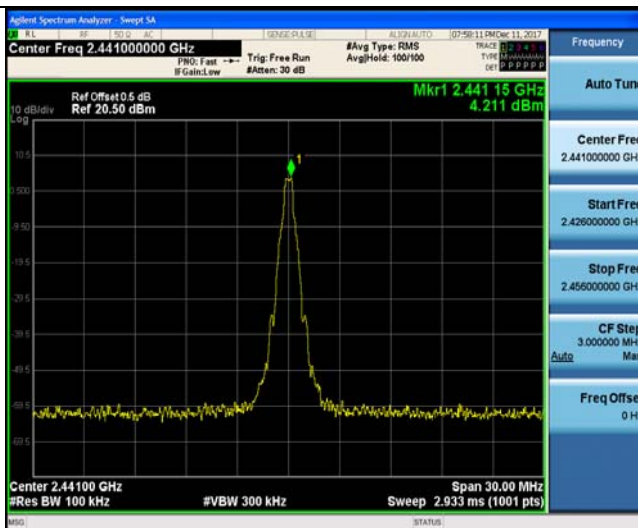

CH39



reference level CH78

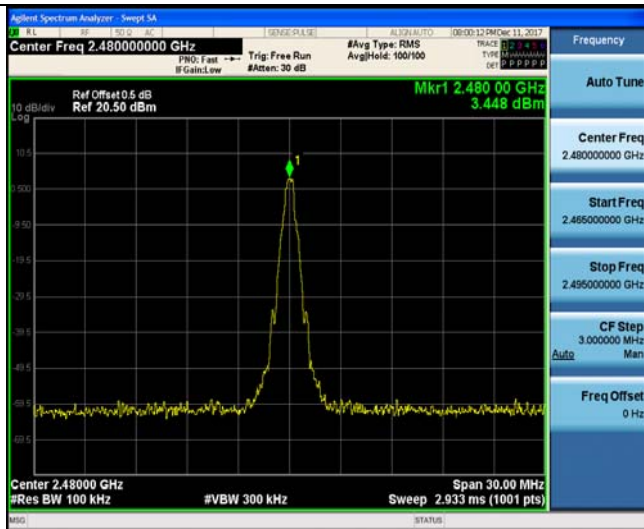

CH78

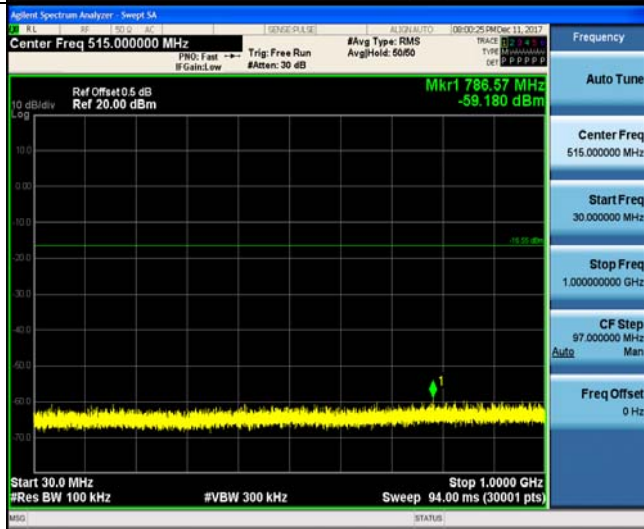

Test Item:	SE	Modulation type:	$\pi/4$ DQPSK
reference level CH00			
CH00			

reference level CH39

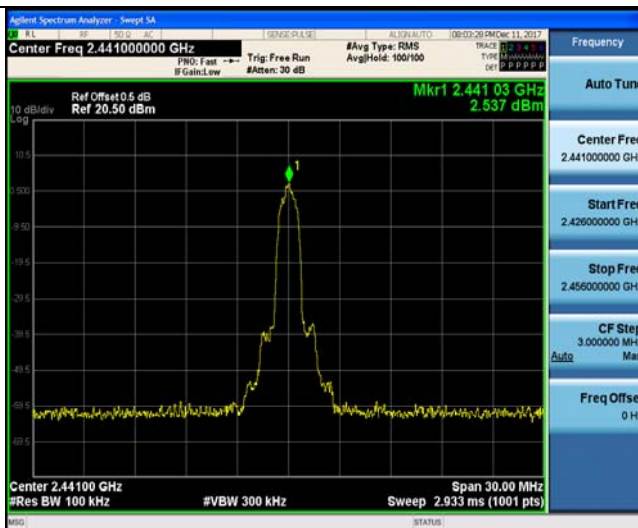

CH39

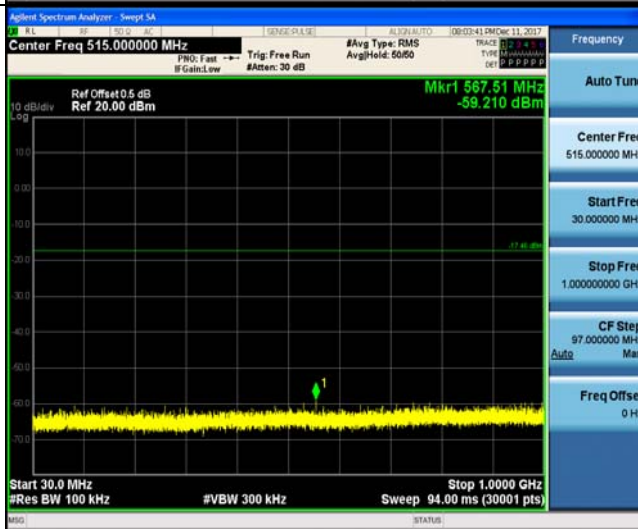

reference level CH78

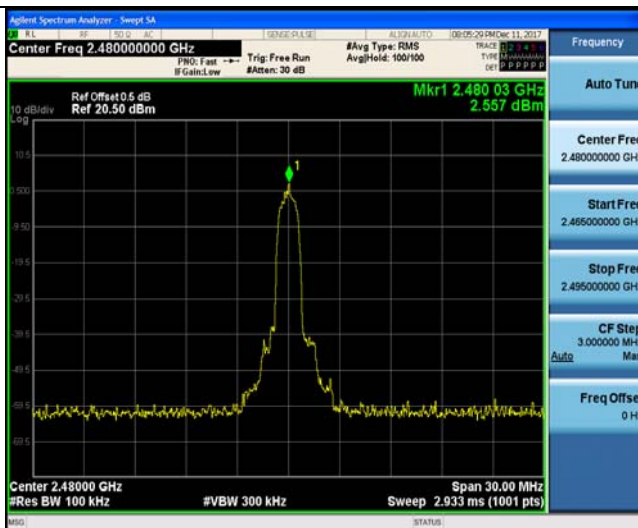

CH78



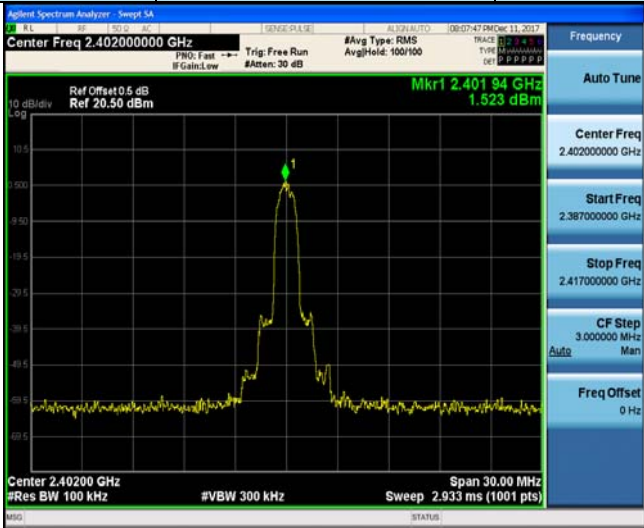
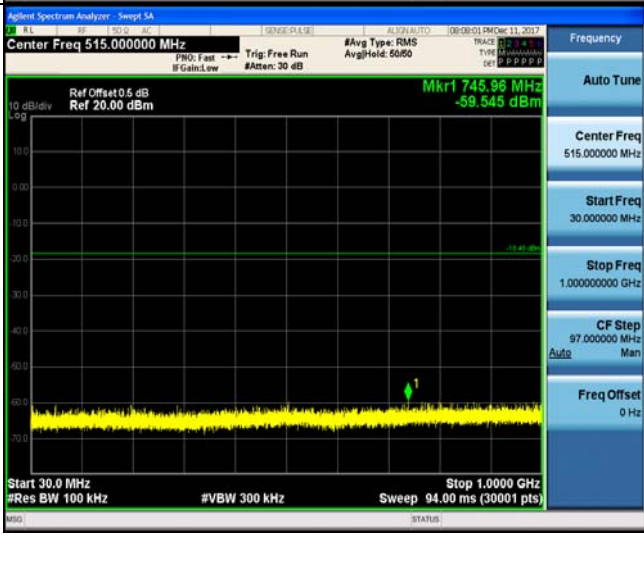
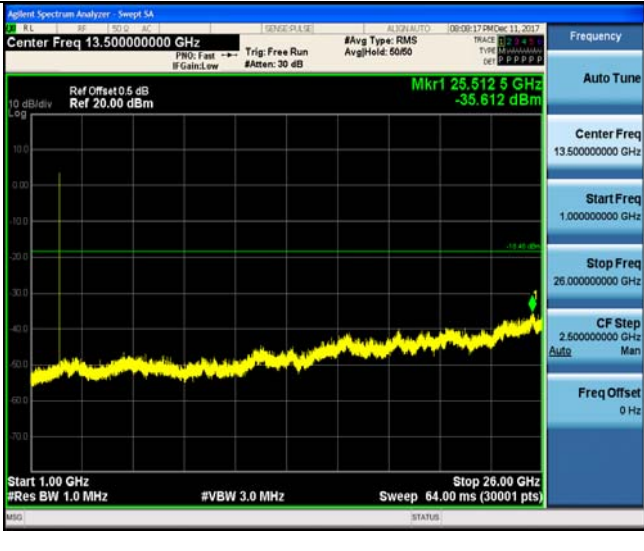

Test Item:	SE	Modulation type:	8DPSK
reference level CH00	 <p>Agilent Spectrum Analyzer - Sweep SA                  Center Freq 2.40200000 GHz                  Ref Offset 0.5 dB                  Ref 20.50 dBm                  Mkr1 2.40194 GHz                  -1.523 dBm                  Span 30.00 MHz                  #Res BW 100 kHz                  #VBW 300 kHz                  Sweep 2.933 ms (1001 pts)</p>		
CH00	 <p>Agilent Spectrum Analyzer - Sweep SA                  Center Freq 515.000000 MHz                  Ref Offset 0.5 dB                  Ref 20.00 dBm                  Mkr1 745.96 MHz                  -59.545 dBm                  Start 30.0 MHz                  Stop 1.0000 GHz                  #Res BW 100 kHz                  #VBW 300 kHz                  Sweep 94.00 ms (30001 pts)</p>		
	 <p>Agilent Spectrum Analyzer - Sweep SA                  Center Freq 13.50000000 GHz                  Ref Offset 0.5 dB                  Ref 20.00 dBm                  Mkr1 25.5125 GHz                  -35.612 dBm                  Start 1.00 GHz                  Stop 26.00 GHz                  #Res BW 1.0 MHz                  #VBW 3.0 MHz                  Sweep 64.00 ms (30001 pts)</p>		

reference level CH39

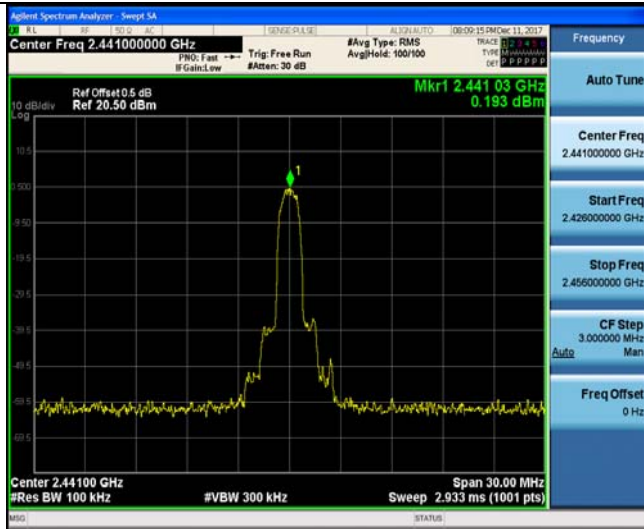

CH39

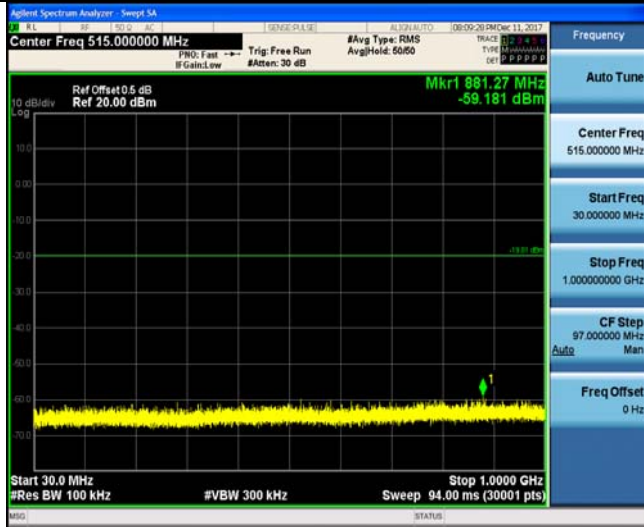



reference level CH78



CH78

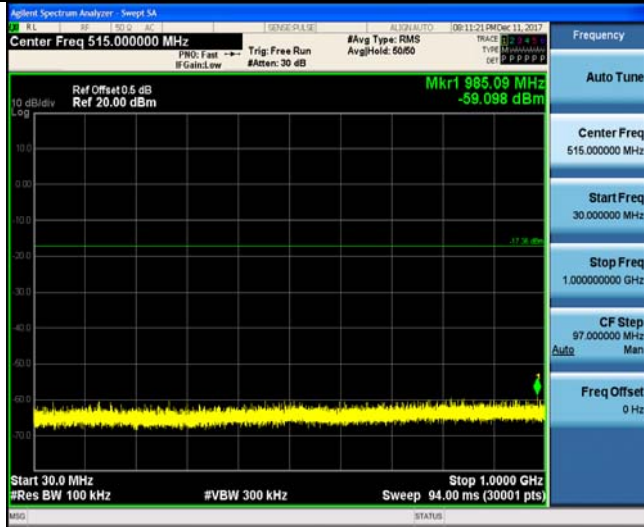

### 5.11. Spurious Emissions (radiated)

#### LIMIT

#### FCC CFR Title 47 Part 15 Subpart C Section 15.209

Frequency	Limit (dBuV/m @3m)	Value
30 MHz ~ 88 MHz	40.00	Quasi-peak
88 MHz ~ 216 MHz	43.50	Quasi-peak
216 MHz ~ 960 MHz	46.00	Quasi-peak
960 MHz ~ 1 GHz	54.00	Quasi-peak
Above 1 GHz	54.00	Average
	74.00	Peak

#### TEST CONFIGURATION

- Below 30 MHz

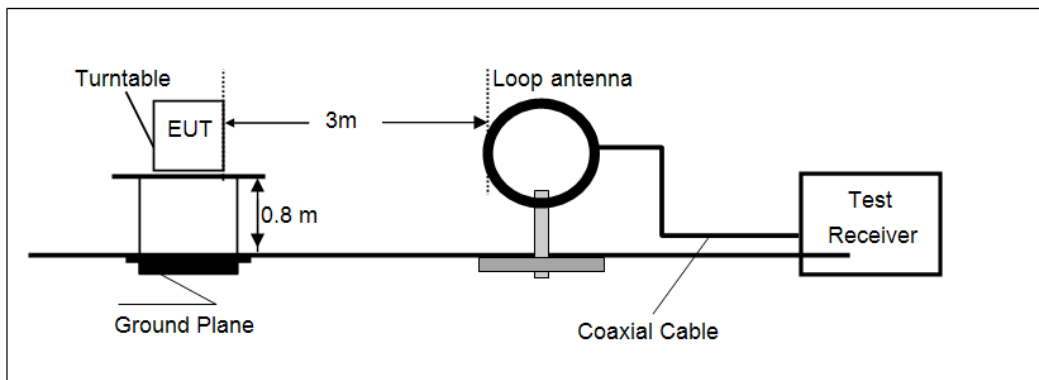

- 30 MHz ~1000 MHz

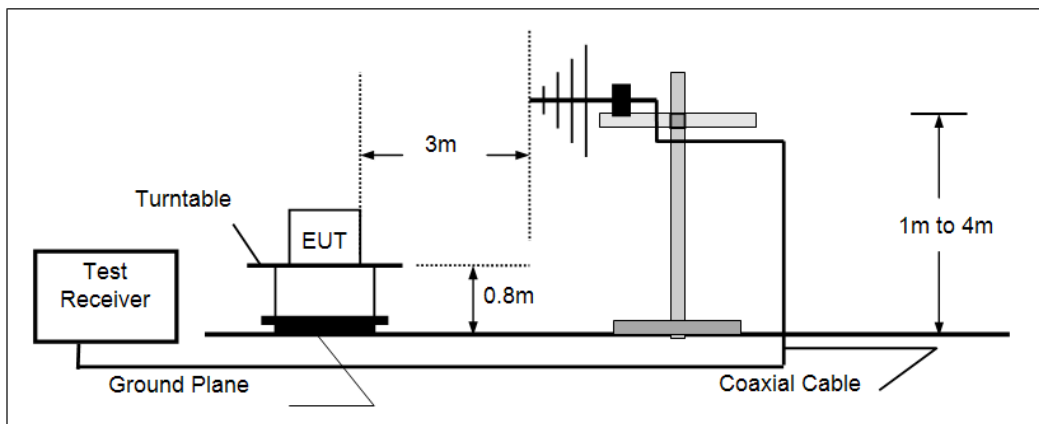

- Above 1 GHz

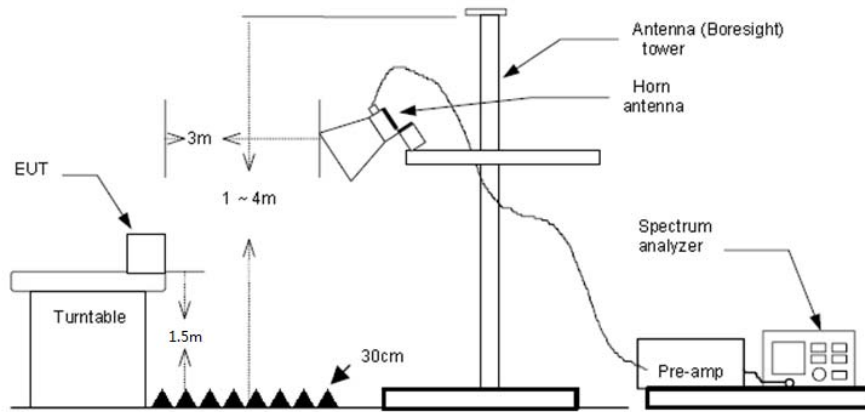

**TEST PROCEDURE**

1. The EUT was tested according to ANSI C63.10:2013.
2. The EUT is placed on a turn table which is 0.8 meter above ground. The turn table is rotated 360 degrees to determine the position of the maximum emission level.
3. The EUT was positioned such that the distance from antenna to the EUT was 3 meters.
4. The antenna is scanned from 1 meter to 4 meters to find out the maximum emission level. This is repeated for both horizontal and vertical polarization of the antenna.
5. Use the following spectrum analyzer settings
  - (1) Span shall wide enough to fully capture the emission being measured;
  - (2) Below 1 GHz, RBW=120 kHz, VBW=300 kHz, Sweep=auto, Detector function=peak, Trace=max hold;  
If the emission level of the EUT measured by the peak detector is 3 dB lower than the applicable limit, the peak emission level will be reported. Otherwise, the emission measurement will be repeated using the quasi-peak detector and reported.
  - (3) Above 1 GHz, RBW=1 MHz, VBW=3 MHz Peak detector for Peak value  
RBW=1 MHz, VBW=10 Hz Peak detector for Average value.

**TEST MODE:**

Please refer to the clause 3.3

**TEST RESULTS**

**Passed**       **Not Applicable**

Note:

- 1) Final Level = Receiver Read level + Antenna Factor + Cable Loss – Preamplifier Factor
- 2) The emission levels of other frequencies are very lower than the limit and not show in test report.
- 3) Below 1 GHz, Have pre-scan all modulation mode, found the GFSK modulation High channel which it was worst case, so only the worst case’s data on the test report.
- 4) Above 1 GHz, Have pre-scan all modulation mode, found the GFSK modulation which it was worst case, so only the worst case’s data on the test report
- 5) The peak level is lower than average limit(54 dBuV/m), this data is the too weak instrument of signal is unable to test.

➤ **9 kHz ~ 30 MHz**

The low frequency, which started from 9 kHz to 30 MHz, was pre-scanned and the result which was 20 dB lower than the limit line per 15.31(o) was not reported.

➤ 30 MHz ~ 1 GHz

Polarization: Vertical

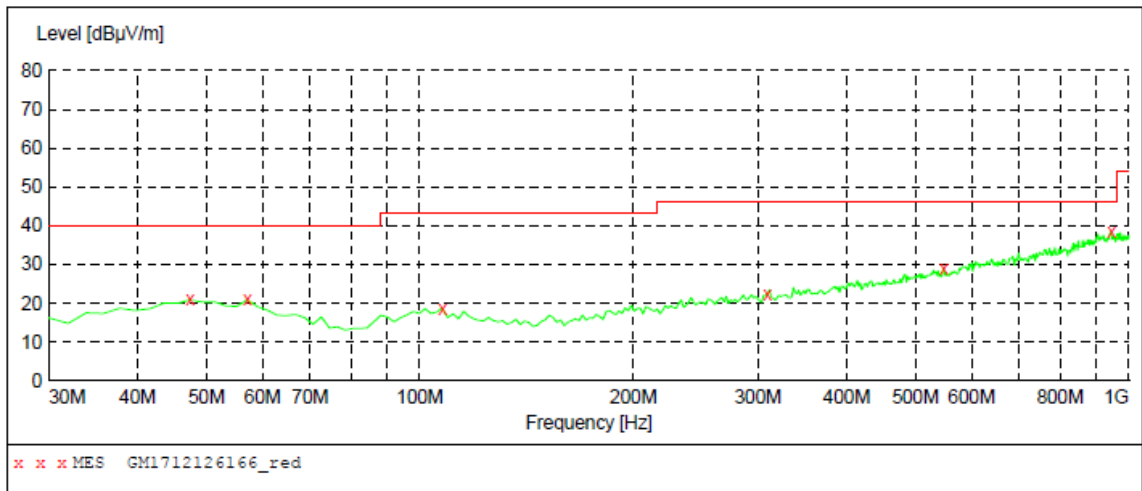

**MEASUREMENT RESULT: "GM1712126166\_red"**

12/12/2017 11:59PM

Frequency MHz	Level dBµV/m	Transd dB	Limit dBµV/m	Margin dB	Det.	Height cm	Azimuth deg	Polarization
47.460000	20.90	-8.8	40.0	19.1	QP	100.0	130.00	VERTICAL
57.160000	20.90	-9.4	40.0	19.1	QP	100.0	336.00	VERTICAL
107.600000	18.80	-10.6	43.5	24.7	QP	100.0	130.00	VERTICAL
309.360000	22.20	-7.1	46.0	23.8	QP	100.0	130.00	VERTICAL
547.980000	29.00	-0.8	46.0	17.0	QP	100.0	248.00	VERTICAL
945.680000	38.30	7.2	46.0	7.7	QP	100.0	351.00	VERTICAL

Polarization: Horizontal

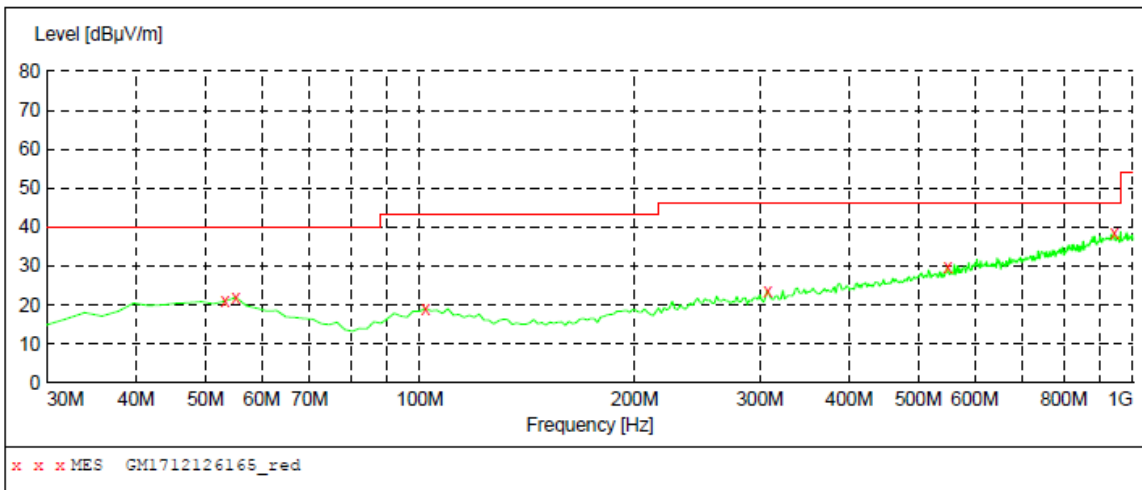

**MEASUREMENT RESULT: "GM1712126165\_red"**

12/12/2017 11:56PM

Frequency MHz	Level dBµV/m	Transd dB	Limit dBµV/m	Margin dB	Det.	Height cm	Azimuth deg	Polarization
53.280000	21.00	-9.0	40.0	19.0	QP	100.0	99.00	HORIZONTAL
55.220000	22.00	-9.2	40.0	18.0	QP	300.0	81.00	HORIZONTAL
101.780000	19.10	-10.5	43.5	24.4	QP	100.0	163.00	HORIZONTAL
307.420000	23.70	-7.1	46.0	22.3	QP	300.0	0.00	HORIZONTAL
549.920000	29.70	-0.8	46.0	16.3	QP	100.0	249.00	HORIZONTAL
941.800000	38.30	7.2	46.0	7.7	QP	300.0	171.00	HORIZONTAL

## ➤ 1 GHz ~ 25 GHz

CH00									
Frequency (MHz)	Read Level (dBuV)	Antenna Factor (dB/m)	Cable Loss (dB)	Preamp Factor (dB)	Level (dBuV/m)	Limit Line (dBuV/m)	Over Limit (dB)	Polarization	Test value
1884.83	47.29	25.31	6.09	37.21	41.48	74.00	-32.52	Vertical	Peak
3700.26	37.50	29.30	8.39	38.25	36.94	74.00	-37.06	Vertical	Peak
4809.50	45.80	31.58	9.55	36.93	50.00	74.00	-24.00	Vertical	Peak
9611.66	36.50	39.07	13.73	35.19	54.11	74.00	-19.89	Vertical	Peak
4809.50	29.50	31.58	9.55	36.93	33.70	54.00	-20.30	Vertical	Average
2081.55	42.75	26.63	6.34	37.32	38.40	74.00	-35.60	Horizontal	Peak
3607.26	37.71	29.30	8.28	38.27	37.02	74.00	-36.98	Horizontal	Peak
4809.50	51.78	31.58	9.55	36.93	55.98	74.00	-18.02	Horizontal	Peak
7209.02	34.77	36.21	11.87	35.07	47.78	74.00	-26.22	Horizontal	Peak
4809.50	39.67	31.58	9.55	36.93	43.87	54.00	-10.13	Horizontal	Average

CH39									
Frequency (MHz)	Read Level (dBuV)	Antenna Factor (dB/m)	Cable Loss (dB)	Preamp Factor (dB)	Level (dBuV/m)	Limit Line (dBuV/m)	Over Limit (dB)	Polarization	Test value
1561.22	36.36	25.24	5.46	36.67	30.39	74.00	-43.61	Vertical	Peak
3184.25	36.03	28.80	7.70	38.20	34.33	74.00	-39.67	Vertical	Peak
4883.52	47.85	31.43	9.59	36.73	52.14	74.00	-21.86	Vertical	Peak
7527.83	32.11	36.13	12.49	34.92	45.81	74.00	-28.19	Vertical	Peak
4883.52	30.24	31.43	9.59	36.73	34.53	54.00	-19.47	Vertical	Average
1626.12	35.36	24.98	5.62	36.77	29.19	74.00	-44.81	Horizontal	Peak
3184.25	35.47	28.80	7.70	38.20	33.77	74.00	-40.23	Horizontal	Peak
4883.52	52.64	31.43	9.59	36.73	56.93	74.00	-17.07	Horizontal	Peak
7319.96	35.94	36.30	11.99	34.92	49.31	74.00	-24.69	Horizontal	Peak
4883.52	32.40	31.43	9.59	36.73	36.69	54.00	-17.31	Horizontal	Average

CH78									
Frequency (MHz)	Read Level (dBuV)	Antenna Factor (dB/m)	Cable Loss (dB)	Preamp Factor (dB)	Level (dBuV/m)	Limit Line (dBuV/m)	Over Limit (dB)	Polarization	Test value
1518.11	36.92	25.63	5.34	36.61	31.28	74.00	-42.72	Vertical	Peak
3625.67	35.91	29.30	8.30	38.26	35.25	74.00	-38.75	Vertical	Peak
4958.68	47.17	31.46	9.64	36.52	51.75	74.00	-22.25	Vertical	Peak
7154.17	32.47	35.93	11.86	35.01	45.25	74.00	-28.75	Vertical	Peak
4958.68	30.37	31.46	9.64	36.52	34.95	54.00	-19.05	Vertical	Average
1711.05	36.24	25.22	5.79	36.95	30.30	74.00	-43.70	Horizontal	Peak
3719.15	35.73	29.36	8.41	38.25	35.25	74.00	-38.75	Horizontal	Peak
4958.68	54.90	31.46	9.64	36.52	59.48	74.00	-14.52	Horizontal	Peak
7451.57	35.85	36.20	12.24	34.86	49.43	74.00	-24.57	Horizontal	Peak
4958.68	34.58	31.46	9.64	36.52	39.16	54.00	-14.84	Horizontal	Average

Remark:

1. Final Level = Receiver Read level + Antenna Factor + Cable Loss – Pre-amplifier Factor
2. The peak level is lower than average limit(54 dBuV/m), this data is the too weak instrument of signal is unable to test.
3. The emission levels of other frequencies(test frequency band is 1GHz to 25GHz) are very lower than the limit and not show in test report.

## 6. TEST SETUP PHOTOS

### Conducted Emissions (AC Mains)



### Radiated Emissions





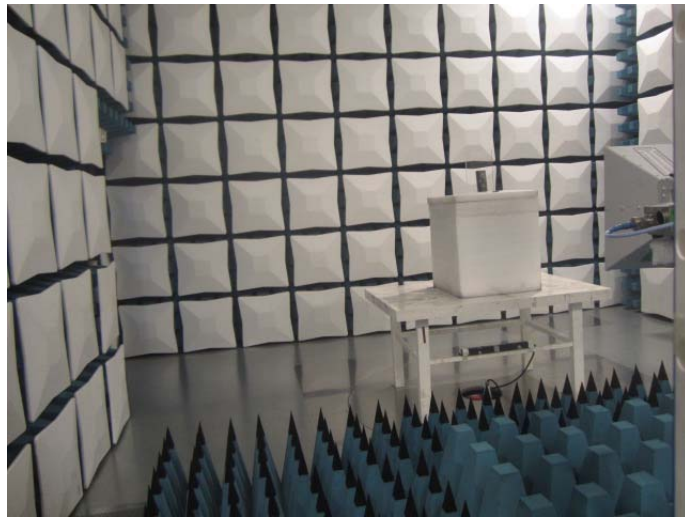

## 7. EXTERANAL AND INTERNAL PHOTOS

Reference to the test report No.: TRE1712002901

.....End of Report.....