

Verykool USA INC.

Mobile Phone

Main Model: S470
Serial Model: N/A



July 26, 2013

Report No.: 13070170-FCC-R4
(This report supersedes none)

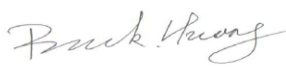
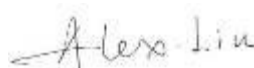

Modifications made to the product : None

This Test Report is Issued Under the Authority of:

		
Back Huang Compliance Engineer	Alex Liu Technical Manager	

This test report may be reproduced in full only.
Test result presented in this test report is applicable to the representative sample only.

RF Test Report

To: FCC Part 15.247: 2012, ANSI C63.4: 2009

SIEMIC, INC.
Accessing global markets



Laboratory Introduction

SIEMIC, headquartered in the heart of Silicon Valley, with superior facilities in US and Asia, is one of the leading independent testing and certification facilities providing customers with one-stop shop services for Compliance Testing and Global Certifications.



In addition to [testing](#) and [certification](#), SIEMIC provides initial design reviews and [compliance management](#) through out a project. Our extensive experience with [China](#), [Asia Pacific](#), [North America](#), [European](#), and [international](#) compliance requirements, assures the fastest, most cost effective way to attain regulatory compliance for the [global markets](#).

Accreditations for Conformity Assessment

Country/Region	Accreditation Body	Scope
USA	FCC, A2LA	EMC , RF/Wireless , Telecom
Canada	IC, A2LA, NIST	EMC, RF/Wireless , Telecom
Taiwan	BSMI , NCC , NIST	EMC, RF, Telecom , Safety
Hong Kong	OFTA , NIST	RF/Wireless ,Telecom
Australia	NATA, NIST	EMC, RF, Telecom , Safety
Korea	KCC/RRA, NIST	EMI, EMS, RF , Telecom, Safety
Japan	VCCI, JATE, TELEC, RFT	EMI, RF/Wireless, Telecom
Mexico	NOM, COFETEL, Caniety	Safety, EMC , RF/Wireless, Telecom
Europe	A2LA, NIST	EMC, RF, Telecom , Safety

Accreditations for Product Certifications

Country/Region	Accreditation Body	Scope
USA	FCC TCB, NIST	EMC , RF , Telecom
Canada	IC FCB , NIST	EMC , RF , Telecom
Singapore	iDA, NIST	EMC , RF , Telecom
EU	NB	EMC & R&TTE Directive
Japan	MIC, (RCB 208)	RF , Telecom
Hong Kong	OFTA (US002)	RF , Telecom



SIEMIC, INC.

Accessing global markets

Title: RF Test Report for Mobile Phone
Main Model: S470
Serial Model: N/A
To: FCC Part 15.247: 2012, ANSI C63.4: 2009

Report No.: 13070170-FCC-R4
Issue Date: July 26, 2013
Page: 3 of 73
www.siemic.com.cn

This page has been left blank intentionally.

CONTENTS

1	EXECUTIVE SUMMARY & EUT INFORMATION	5
2	TECHNICAL DETAILS.....	6
3	MODIFICATION.....	7
4	TEST SUMMARY.....	8
5	MEASUREMENTS, EXAMINATION AND DERIVED RESULTS.....	9
	ANNEX A. TEST INSTRUMENT & METHOD	52
	ANNEX B. EUT AND TEST SETUP PHOTOGRAPHS	57
	ANNEX C. TEST SETUP AND SUPPORTING EQUIPMENT.....	68
	ANNEX D. USER MANUAL / BLOCK DIAGRAM / SCHEMATICS / PART LIST	72
	ANNEX E. DECLARATION OF SIMILARITY	73

1 EXECUTIVE SUMMARY & EUT INFORMATION

The purpose of this test programme was to demonstrate compliance of the Verykool USA INC., Mobile Phone and model: S470 against the current Stipulated Standards. The Mobile Phone has demonstrated compliance with the FCC Part 15.247: 2012, ANSI C63.4: 2009.

EUT Information

EUT Description	: Mobile Phone
Main Model	: S470
Serial Model	: N/A
Antenna Gain	: GSM850: -1.35 dBi : PCS1900: -0.91 dBi : UMTS-FDD Band V: -0.96 dBi : UMTS-FDD Band II: -0.87 dBi : Bluetooth/ WIFI: -1.15 dBi : GPS: -1.06 dBi
Input Power	: Battery: : Model: KLB200N282 : Li-ion Battery: 3.7V 2000mAh : Limited charger voltage: 4.2V : Adapter: : Model: SKL-5WU-U050-1000 : Input: AC 100-240V 50/60Hz 0.15A MAX : Output: DC 5V 1000mA
Classification Per Stipulated Test Standard	: FCC Part 15.247: 2012, ANSI C63.4: 2009

**SIEMIC, INC.**

Accessing global markets

Title: RF Test Report for Mobile Phone
 Main Model: S470
 Serial Model: N/A
 To: FCC Part 15.247: 2012, ANSI C63.4: 2009

Report No.: 13070170-FCC-R4
 Issue Date: July 26, 2013
 Page: 6 of 73
 www.siemic.com.cn

2 TECHNICAL DETAILS

Purpose	Compliance testing of Mobile Phone with stipulated standard
Applicant / Client	Verykool USA INC. 3636 Nobel Drive, Suite 325, San Diego, CA 92122, USA
Manufacturer	ShenZhen Konka Telecommunication Technology Co., ltd Overseas Chinese Town nanshan district, Shenzhen, China
Laboratory performing the tests	Zone A, Floor 1, Building 2, Wan Ye Long Technology Park, South Side of Zhoushi Road, Bao'an District, Shenzhen, Guangdong, China Tel: +86-0755-2601 4629 / 2601 4953 Fax: +86-0755-2601 4953-810 Email: China@siemic.com.cn
Test report reference number	13070170-FCC-R4
Date EUT received	July 08, 2013
Standard applied	FCC Part 15.247: 2012, ANSI C63.4: 2009
Dates of test (from – to)	July 22, 2013 - July 24, 2013
No of Units :	#1
Equipment Category :	Spread Spectrum System/Device
Trade Name :	Verykool
RF Operating Frequency (ies)	GSM850 TX : 824.2 ~ 848.8 MHz; RX : 869.2 ~ 893.8 MHz PCS1900 TX : 1850.2 ~ 1909.8 MHz; RX : 1930.2 ~ 1989.8 MHz UMTS-FDD Band V TX : 826.4 ~ 846.6 MHz; RX : 871.4 ~ 891.6 MHz UMTS-FDD Band II TX : 1852.4 ~ 1907.6 MHz; RX : 1932.4 ~ 1987.6 MHz 802.11b/g/n: 2412-2462 MHz Bluetooth & BLE: 2402-2480 MHz
Number of Channels	299CH (PCS1900) and 124CH (GSM850) UMTS-FDD Band V : 102CH UMTS-FDD Band II : 277CH Bluetooth: 79CH 802.11b/g/n(20M): 11CH BLE: 40CH
Modulation	GSM / GPRS: GMSK UMTS-FDD: QPSK 802.11b/g/n: DSSS/OFDM Bluetooth: GFSK&π/4DQPSK&8DPSK BLE: GFSK
GPRS Multi-slot class	8/10/12
FCC ID	WA6S470



SIEMIC, Inc.

Accessing global markets

Title: RF Test Report for Mobile Phone
Main Model: S470
Serial Model: N/A
To: FCC Part 15.247: 2012, ANSI C63.4: 2009

Report No.: 13070170-FCC-R4
Issue Date: July 26, 2013
Page: 7 of 73
www.siemic.com.cn

3 MODIFICATION

NONE

4 TEST SUMMARY

The product was tested in accordance with the following specifications.
 All testing has been performed according to below product classification:

Test Results Summary

FCC Rules	Description of Test	Result
§15.247 (i), §2.1093	RF Exposure	Compliance
§15.203	Antenna Requirement	Compliance
§15.247 (a)(2)	DTS (6 dB&26 dB) CHANNEL BANDWIDTH	Compliance
§15.247(b)(3)	Conducted Maximum Output Power	Compliance
§15.247(e)	Power Spectral Density	Compliance
§15.247(d)	Band-Edge & Unwanted Emissions into Non-Restricted Frequency Bands	Compliance
§15.207 (a),	AC Power Line Conducted Emissions	Compliance
§15.205, §15.209, §15.247(d)	Radiated Spurious Emissions & Unwanted Emissions into Restricted Frequency Bands	Compliance

5 MEASUREMENTS, EXAMINATION AND DERIVED RESULTS

5.1 §15.247 (i) and §2.1093 – RF Exposure

Standard Requirement:

According to §15.247 (i) and §1.1307(b)(1), systems operating under the provisions of this section shall be operated in a manner that ensures that the public is not exposed to radio frequency energy level in excess of the Commission’s guidelines.

The 1-g and 10-g SAR test exclusion thresholds for 100 MHz to 6 GHz at *test separation distances* ≤ 50 mm are determined by:

$$[(\text{max. power of channel, including tune-up tolerance, mW}) / (\text{min. test separation distance, mm})] \cdot [\sqrt{f_{\text{GHz}}}] \leq 3.0 \text{ for 1-g SAR and } \leq 7.5 \text{ for 10-g extremity SAR,}^{16} \text{ where}$$

- f_{GHz} is the RF channel transmit frequency in GHz
- Power and distance are rounded to the nearest mW and mm before calculation¹⁷
- The result is rounded to one decimal place for comparison

The test exclusions are applicable only when the minimum *test separation distance* is ≤ 50 mm and for transmission frequencies between 100 MHz and 6 GHz. When the minimum *test separation distance* is < 5 mm, a distance of 5 mm is applied to determine SAR test exclusion.

Approximate SAR Test Exclusion Power Thresholds at Selected Frequencies and Test Separation Distances are illustrated in the following Table.

MHz	5	10	15	20	25	mm
150	39	77	116	155	194	SAR Test Exclusion Threshold (mW)
300	27	55	82	110	137	
450	22	45	67	89	112	
835	16	33	49	66	82	
900	16	32	47	63	79	
1500	12	24	37	49	61	
1900	11	22	33	44	54	
2450	10	19	29	38	48	
3600	8	16	24	32	40	
5200	7	13	20	26	33	
5400	6	13	19	26	32	
5800	6	12	19	25	31	

Routine SAR evaluation refers to that specifically required by § 2.1093, using measurements or computer simulation. When routine SAR evaluation is not required, portable transmitters with output power greater than the applicable low threshold require SAR evaluation to qualify for TCB approval.

Three antennas are available for the EUT (GSM/WCDMA antenna, Bluetooth/WIFI antenna, GPS antenna).

the maximum average output power(turn-up power) of WIFI is 8.88 dBm=7.73 mW < 9.6 mW

According to KDB 447498, no stand-alone required for WIFI antenna, and no simultaneous SAR measurement is required , please refer to SAR report.

Test Result: Pass

5.2 §15.203 - ANTENNA REQUIREMENT

Applicable Standard

According to § 15.203, an intentional radiator shall be designed to ensure that no antenna other than that furnished by the responsible party shall be used with the device. The use of a permanently attached antenna or of an antenna that uses a unique coupling to the intentional radiator shall be considered sufficient to comply with the provisions of this section. The manufacturer may design the unit so that a broken antenna can be replaced by the user, but the user of a standard antenna jack or electrical connector is prohibited. The structure and application of the EUT were analyzed to determine compliance with section §15.203 of the rules. §15.203 state that the subject device must meet the following criteria:

- a. Antenna must be permanently attached to the unit.
- b. Antenna must use a unique type of connector to attach to the EUT.

Unit must be professionally installed, and installer shall be responsible for verifying that the correct antenna is employed with the unit.

And according to FCC 47 CFR section 15.247 (b), if the transmitting antennas of directional gain greater than 6dBi are used, the power shall be reduced by the amount in dB that the directional gain of the antenna exceeds 6 dBi.

Antenna Connector Construction

The EUT has 3 antennas: . a PIFA antenna for Bluetooth and WIFI, the gain is both -1.15 dBi;
a PIFA antenna for GSM and WCDMA the gain is -1.35 dBi for GSM, -0.91 dBi for PCS,
-0.96 dBi for Band V , -0.87 dBi for Band II ;
.a PIFA antenna for GPS, the gain is -1.06 dBi.

which in accordance to section 15.203, please refer to the internal photos.

Result: Compliance.

5.3 §15.247(a) (2) –DTS (6 dB&26 dB) CHANNEL BANDWIDTH

1. Conducted Measurement
 EUT was set for low, mid, high channel with modulated mode and highest RF output power.
 The spectrum analyzer was connected to the antenna terminal.
2. Environmental Conditions

Temperature	26°C
Relative Humidity	58%
Atmospheric Pressure	1019mbar
3. Conducted Emissions Measurement Uncertainty
 All test measurements carried out are traceable to national standards. The uncertainty of the measurement at a confidence level of approximately 95% (in the case where distributions are normal), with a coverage factor of 2, in the range 30MHz – 40GHz is ±1.5dB.
4. Test date : June 22, 2013
 Tested By : Back Huang

Requirement(s): The minimum 6 dB bandwidth of a DTS transmission shall be at least 500 kHz. Within this document, this bandwidth is referred to as the DTS bandwidth. The procedures provided herein for measuring the maximum peak conducted output power assume the use of the DTS bandwidth.

Procedures:

1. Set RBW = 100 kHz.
2. Set the video bandwidth (VBW) $\geq 3 \times$ RBW.
3. Detector = Peak.
4. Trace mode = max hold.
5. Sweep = auto couple.
6. Allow the trace to stabilize.
7. Measure the maximum width of the emission that is constrained by the frequencies associated with the two outermost amplitude points (upper and lower) that are attenuated by 6 dB relative to the maximum level measured in the fundamental emission.

Test Result: Pass.

Please refer to the following tables and plots.

6dB bandwidth:

Channel	Channel Frequency (MHz)	Data Rate (Mbps)	Measured 6dB Bandwidth (MHz)	FCC Part 15.247 Limit (kHz)
802.11b mode				
Low	2412	1	9.110	> 500
Middle	2437	1	9.101	> 500
High	2462	1	9.129	> 500
802.11g mode				
Low	2412	6	16.471	> 500
Middle	2437	6	16.478	> 500
High	2462	6	16.495	> 500
802.11n(20M) mode				
Low	2412	MCS0	17.675	> 500
Middle	2437	MCS0	17.658	> 500
High	2462	MCS0	17.681	> 500

802.11b Low Channel

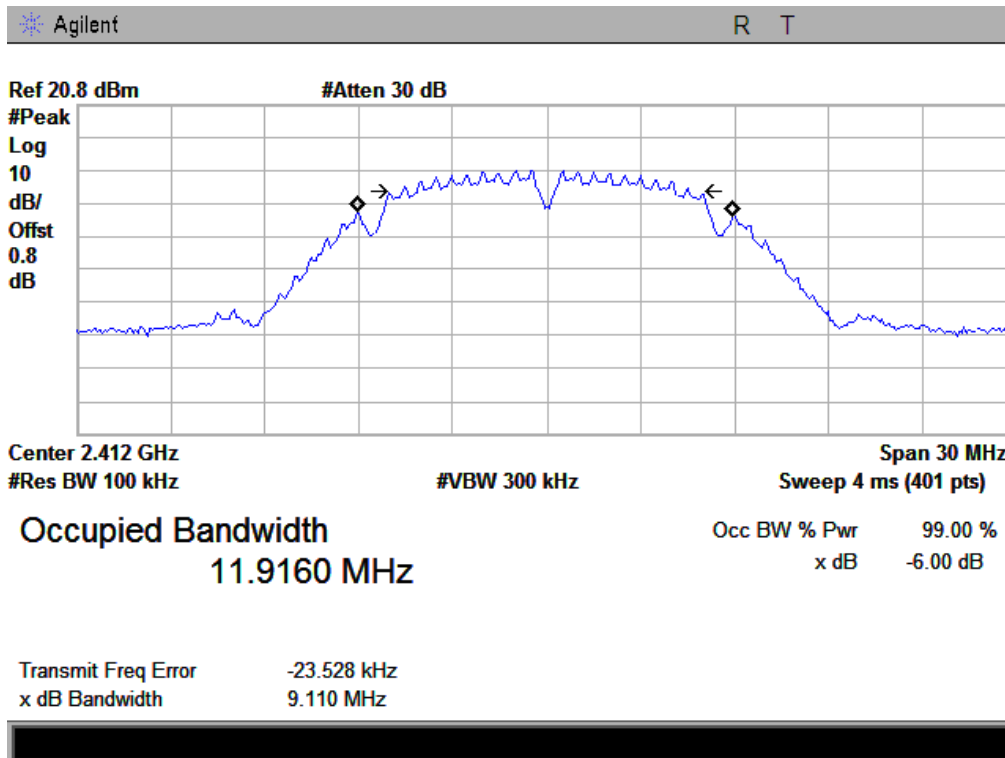

802.11b Middle Channel

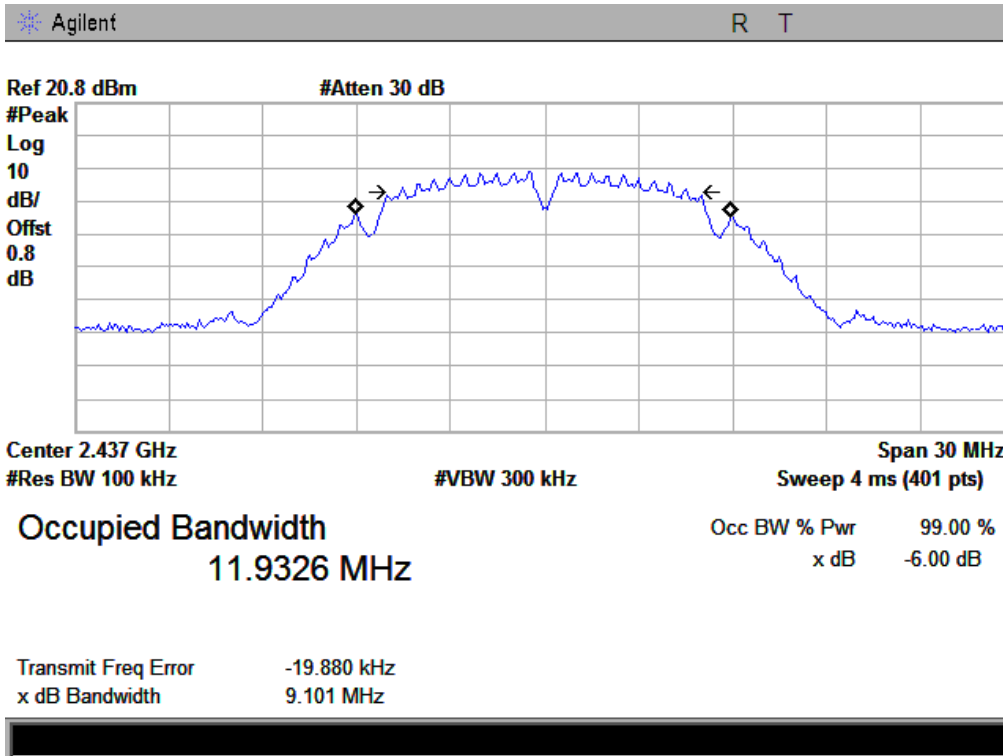

802.11b High Channel

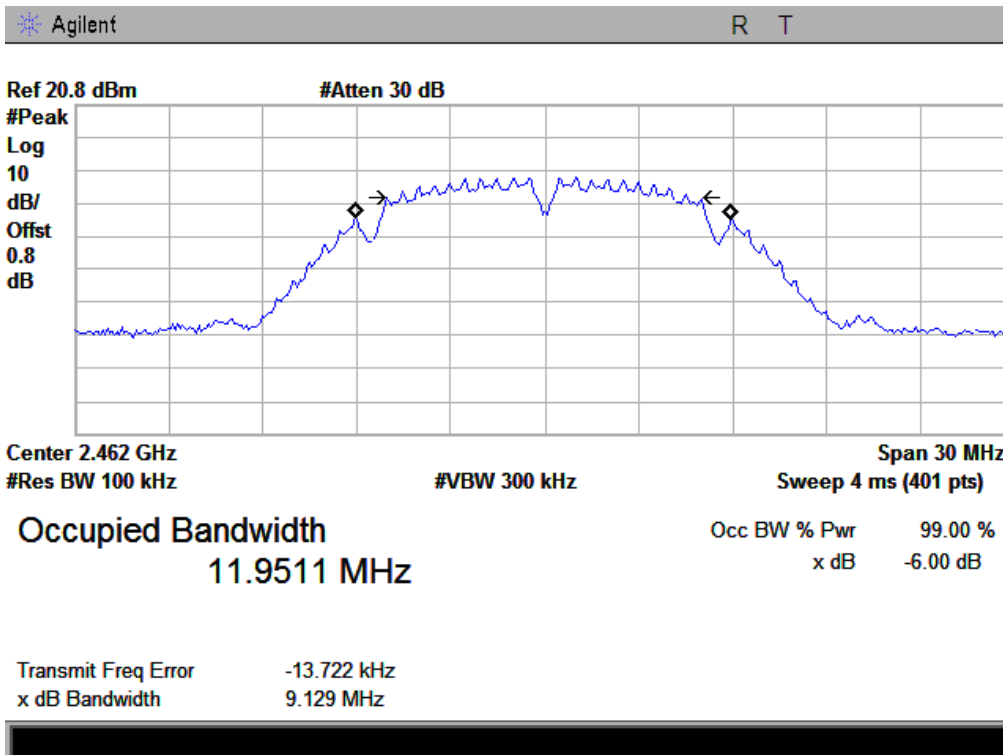

802.11g Low Channel

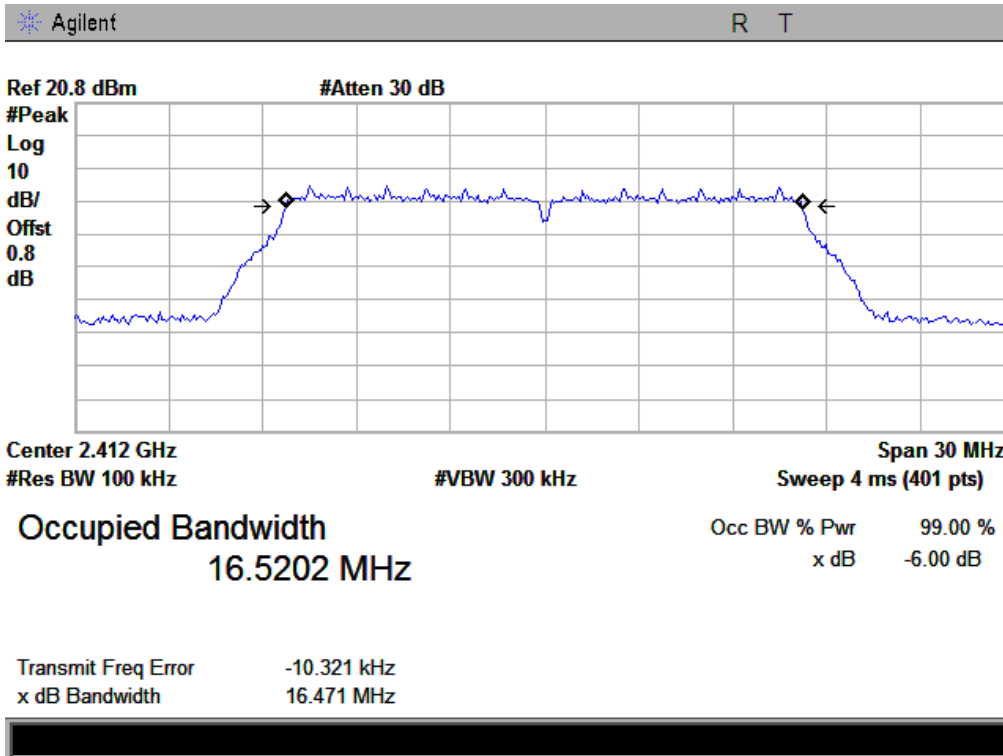

802.11g Middle Channel

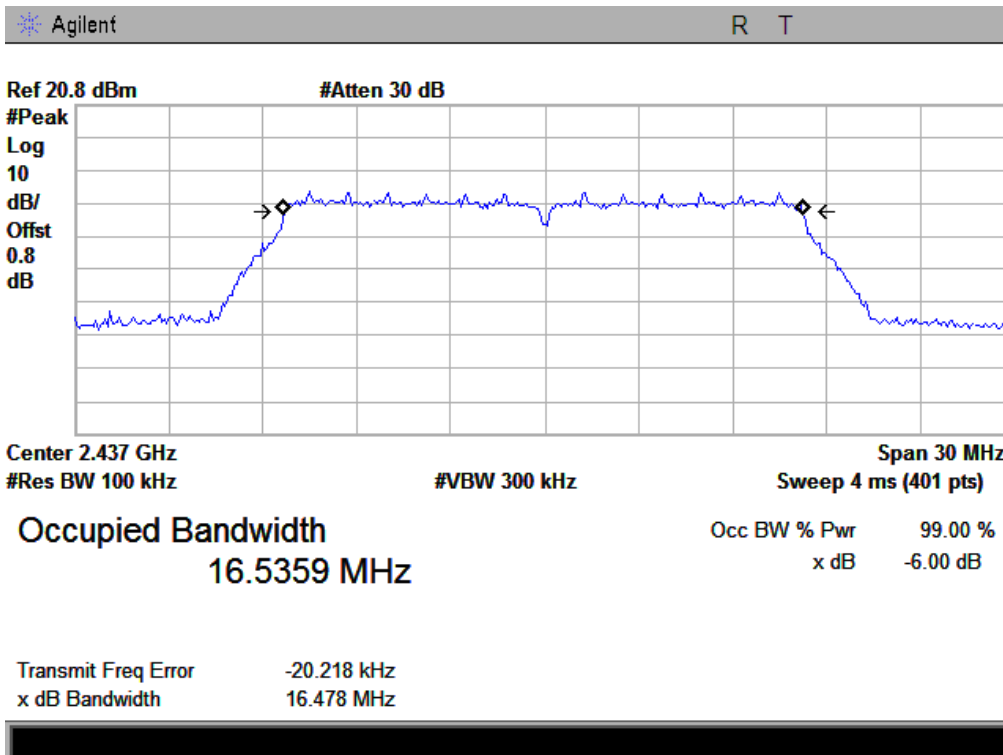

802.11g High Channel

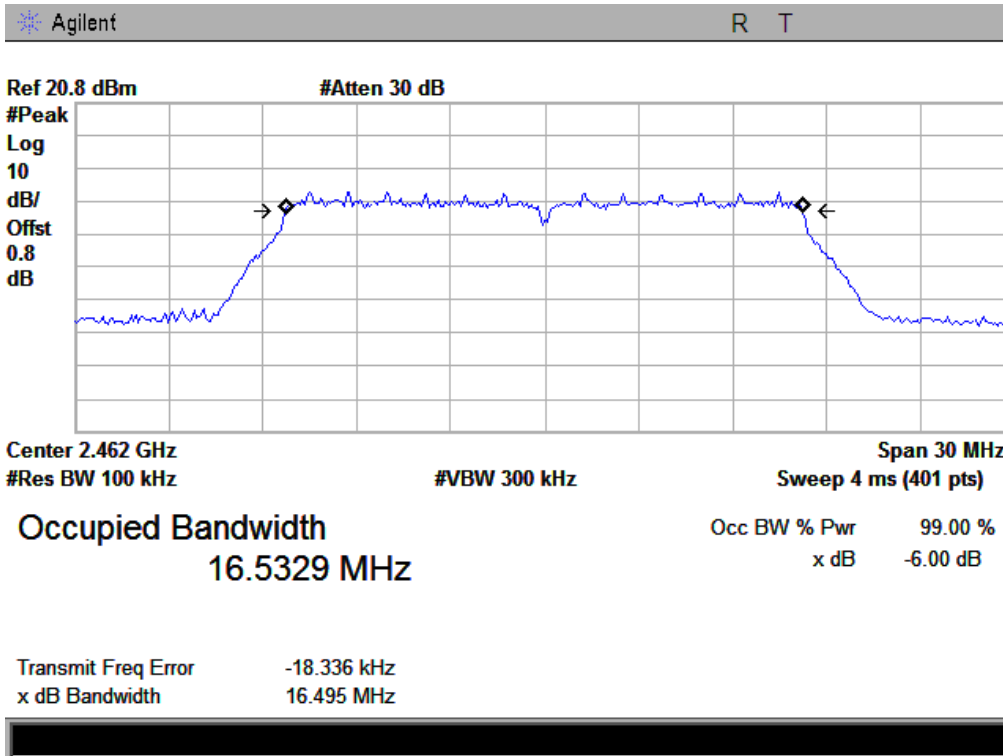

802.11n Low Channel

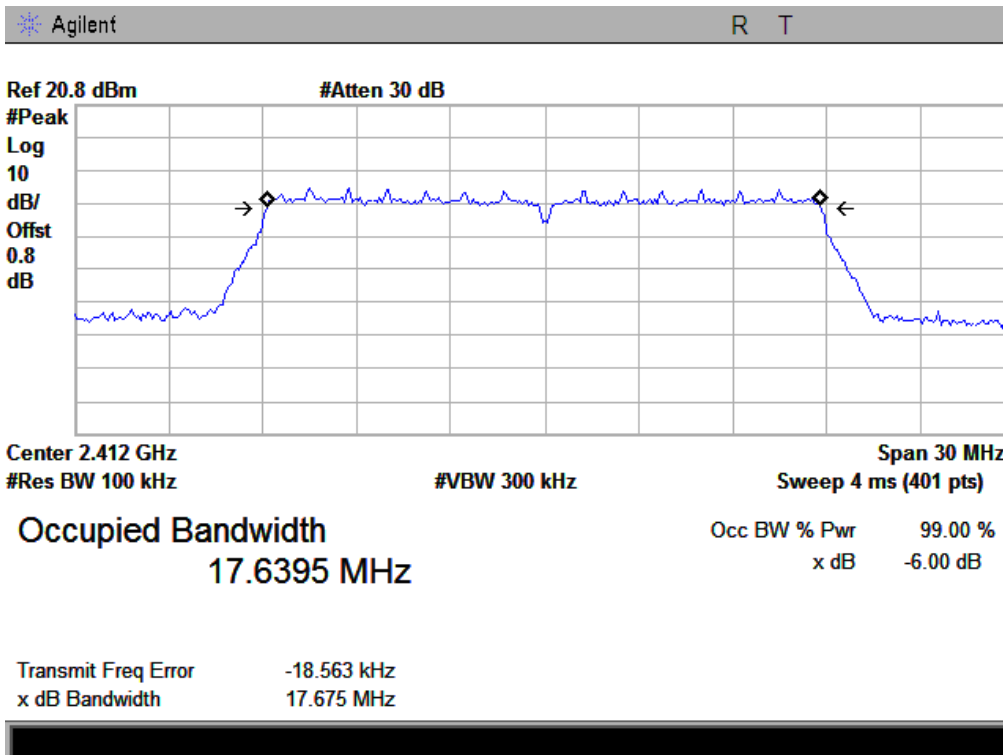



SIEMIC, INC.

Accessing global markets

Title: RF Test Report for Mobile Phone
Main Model: S470
Serial Model: N/A
To: FCC Part 15.247: 2012, ANSI C63.4: 2009

Report No.: 13070170-FCC-R4
Issue Date: July 26, 2013
Page: 16 of 73
www.siemic.com.cn

802.11n Middle Channel

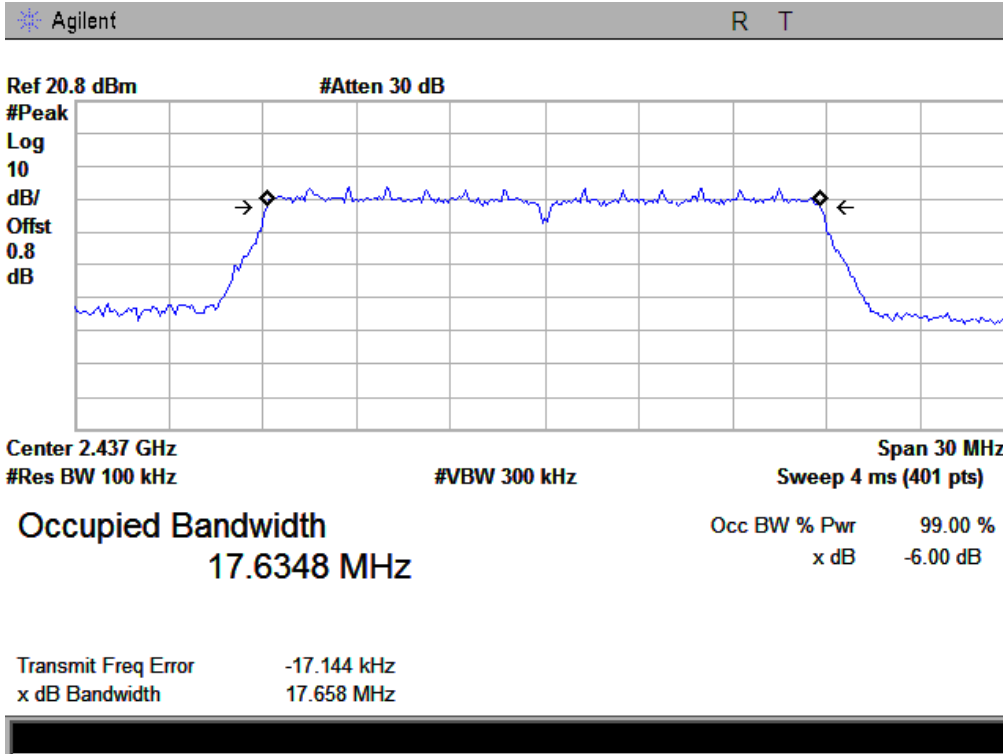

802.11n High Channel

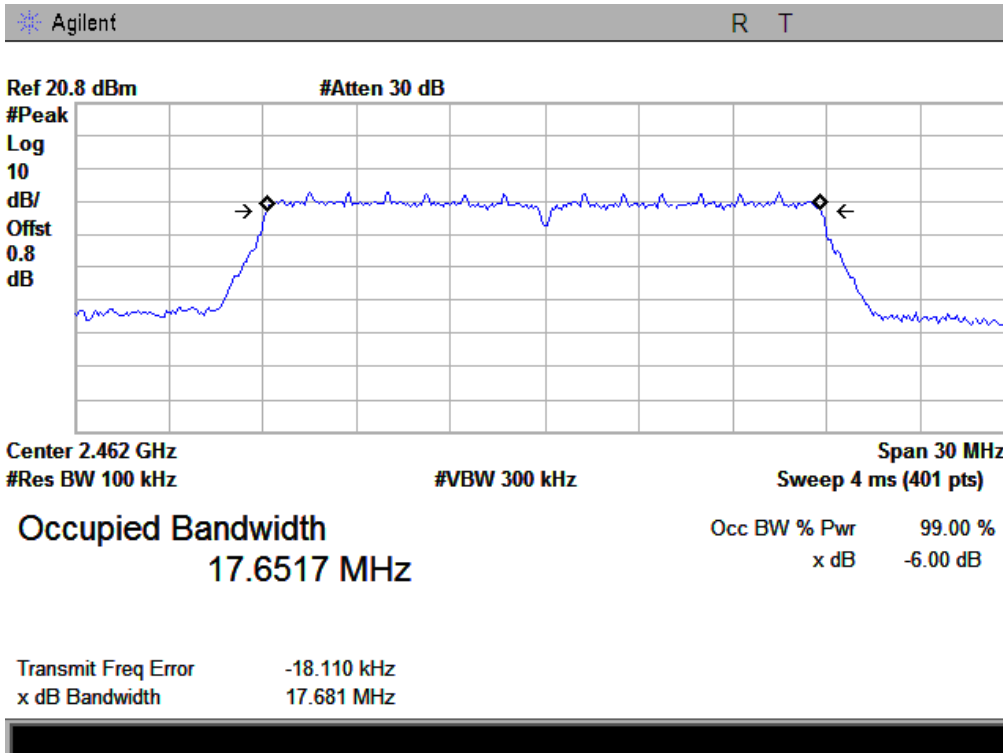

The 20dB bandwidth:

802.11b Low Channel

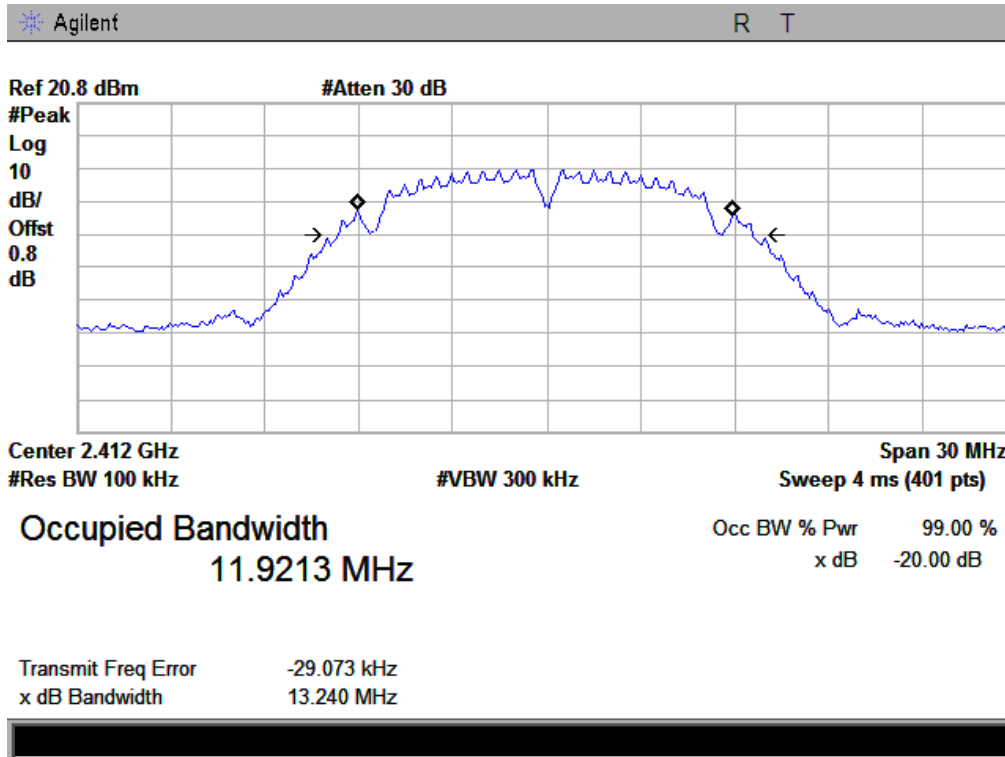

802.11b Middle Channel

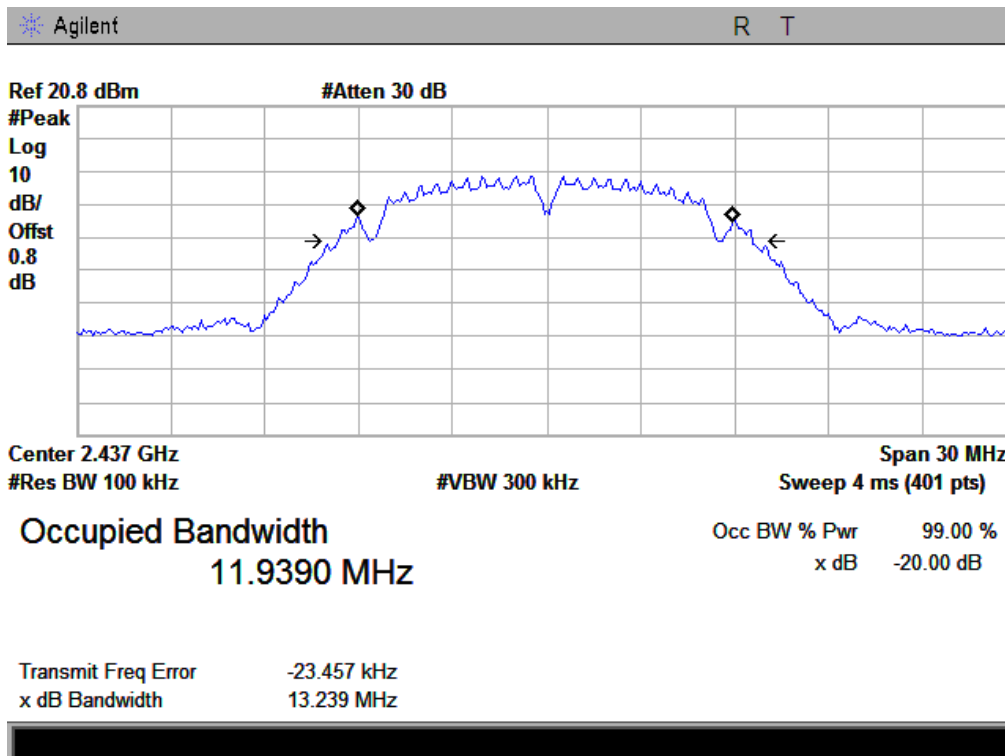

802.11b High Channel

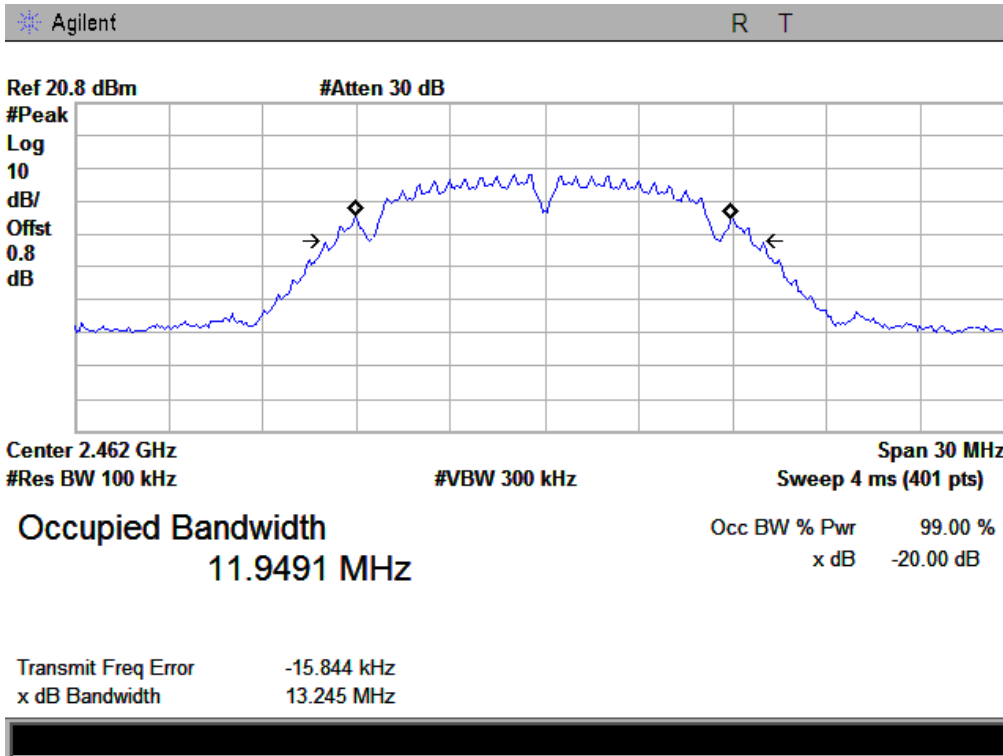

802.11g Low Channel

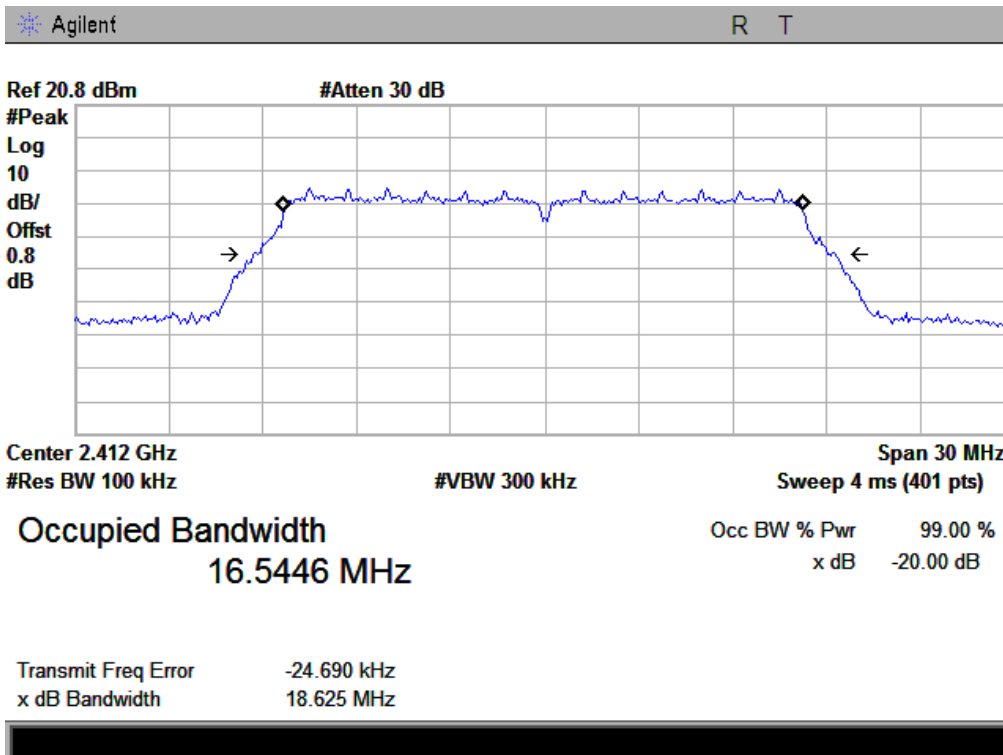



SIEMIC, INC.

Accessing global markets

Title: RF Test Report for Mobile Phone
Main Model: S470
Serial Model: N/A
To: FCC Part 15.247: 2012, ANSI C63.4: 2009

Report No.: 13070170-FCC-R4
Issue Date: July 26, 2013
Page: 19 of 73
www.siemic.com.cn

802.11g Middle Channel

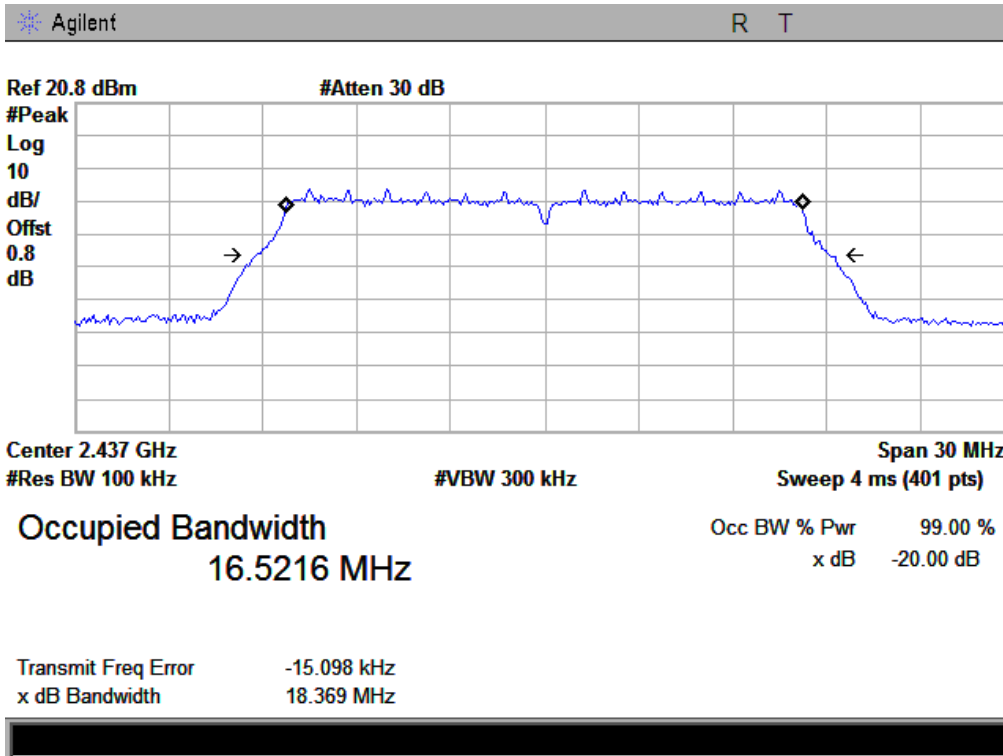

802.11g High Channel

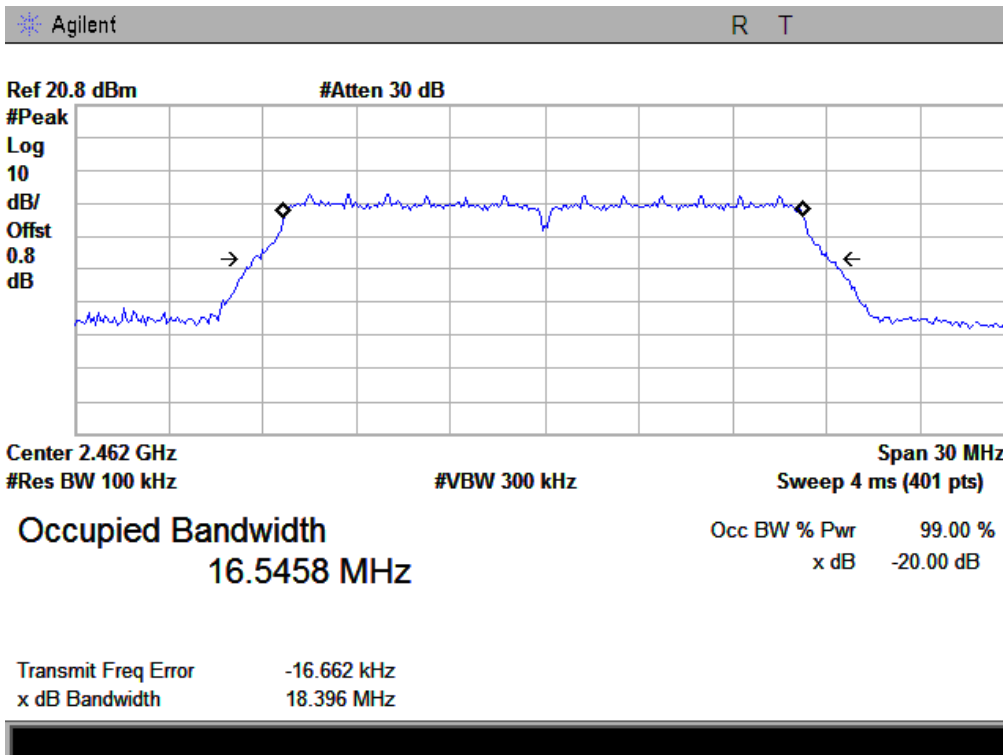



SIEMIC, INC.

Accessing global markets

Title: RF Test Report for Mobile Phone
Main Model: S470
Serial Model: N/A
To: FCC Part 15.247: 2012, ANSI C63.4: 2009

Report No.: 13070170-FCC-R4
Issue Date: July 26, 2013
Page: 20 of 73
www.siemic.com.cn

802.11n Low Channel

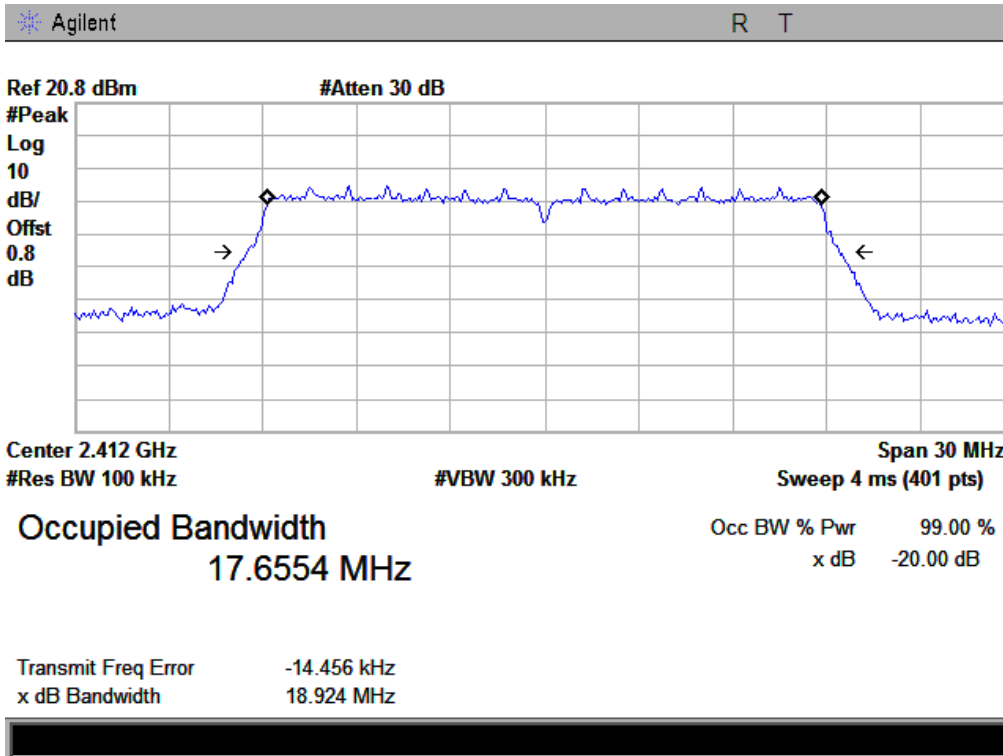

802.11 Middle Channel

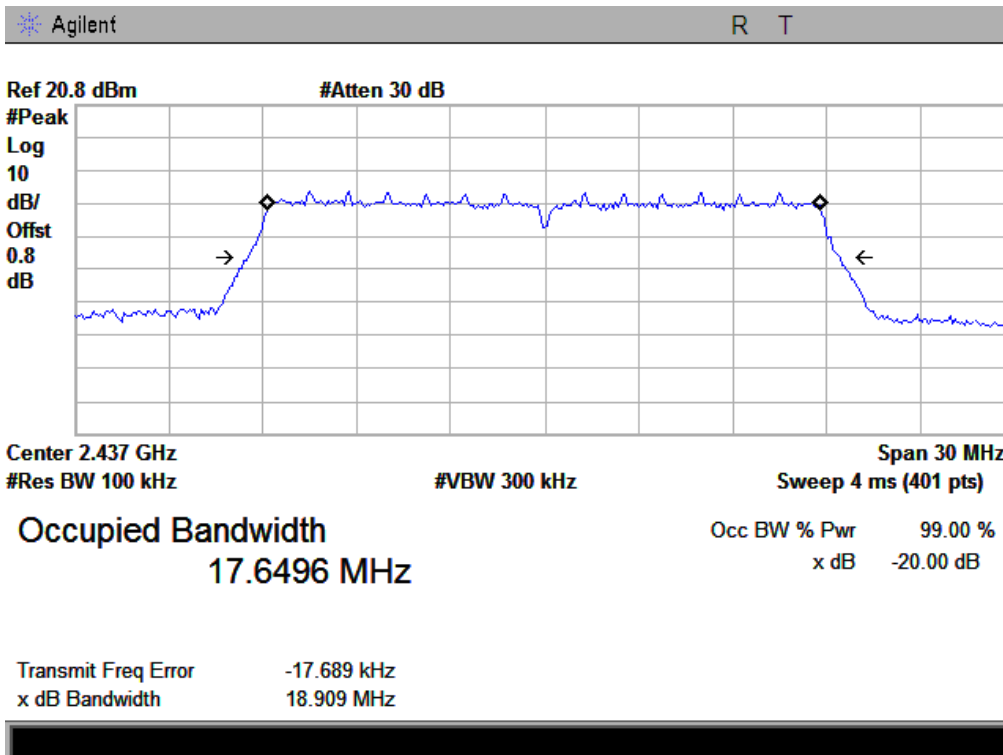

802.11n High Channel

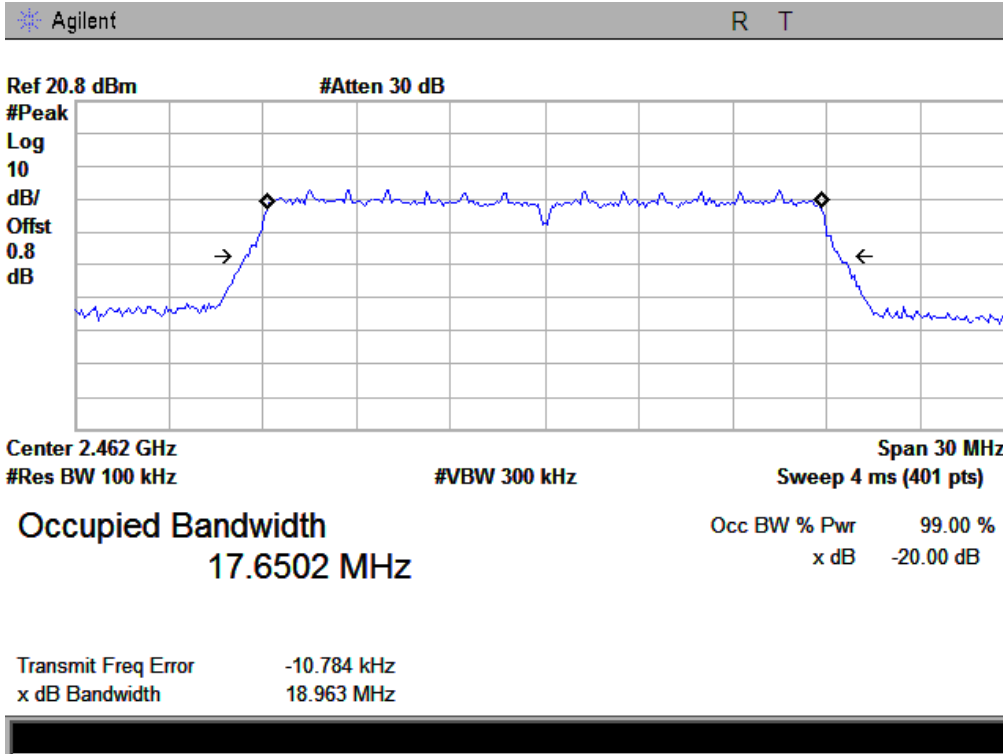

5.4 §15.247(b) (3) - Conducted Maximum Output Power

1. Conducted Measurement
EUT was set for low, mid, high channel with modulated mode and highest RF output power.
The spectrum analyzer was connected to the antenna terminal.
2. Conducted Emissions Measurement Uncertainty
All test measurements carried out are traceable to national standards. The uncertainty of the measurement at a confidence level of approximately 95% (in the case where distributions are normal), with a coverage factor of 2, in the range 30MHz – 40GHz is $\pm 1.5\text{dB}$.
3. Environmental Conditions

Temperature	26°C
Relative Humidity	58%
Atmospheric Pressure	1019mbar
4. Test date : July 22, 2013
Tested By : Back Huang

Standard Requirement:

Maximum Peak Conducted Output Power

The following procedures can be used to determine the maximum peak conducted output power of a DTS EUT.

Maximum Conducted Output Power

§15.247(b)(3) permits the maximum (average) conducted output power to be measured as an alternative to the maximum peak conducted output power for demonstrating compliance to the limit. When these procedures are utilized, the power is referenced to the emission bandwidth (EBW) rather than the DTS bandwidth (see Section 2.0 for definitions).

When using a spectrum/signal analyzer to perform these measurements, it must be capable of utilizing a number of measurement points in each sweep that is greater than or equal to twice the span/RBW in order to ensure bin-to-bin spacing of $\leq \text{RBW}/2$ so that narrowband signals are not lost between frequency bins.

The ideal method for measuring the maximum (average) conducted output power is with the EUT is configured to transmit continuously (duty cycle $\geq 98\%$) at its maximum power control level. However, when this condition cannot be realized, video triggering or signal gating can be used to ensure that the measurements are performed only during periods when the EUT is transmitting at its maximum power control level. An option is also provided that can be used when none of the above requirements can be met with the available measurement instrumentation.

Procedures:

Maximum peak conducted output power:

Integrated band power method

This procedure may be used when the maximum available RBW of the measurement instrument is less than the DTS bandwidth.

1. Set the RBW = 1 MHz.
2. Set the VBW $\geq 3 \times \text{RBW}$
3. Set the span $\geq 1.5 \times \text{DTS bandwidth}$.
4. Detector = peak.
5. Sweep time = auto couple.
6. Trace mode = max hold.
7. Allow trace to fully stabilize.
8. Use the instrument's band/channel power measurement function with the band limits set equal to the DTS bandwidth edges (for some instruments, this may require a manual override to select peak detector). If the instrument does not have a band power function, sum the spectrum levels (in linear power units) at intervals equal to the RBW extending across the DTS bandwidth.

Maximum conducted (average) output power:

Method AVGSA-1 (trace averaging with the EUT transmitting at full power throughout each sweep)

This procedure should be used with an RMS power averaging detector; however, a sample detector can be used when an RMS detector is not available. This is the baseline method for measuring the maximum (average) conducted output power.

1. Set span to at least 1.5 times the OBW.
2. Set RBW = 1-5% of the OBW, not to exceed 1 MHz.
3. Set VBW $\geq 3 \times \text{RBW}$.
4. Number of points in sweep $\geq 2 \times \text{span} / \text{RBW}$. (This gives bin-to-bin spacing $\leq \text{RBW}/2$, so that narrowband signals

are not lost between frequency bins.)

5. Sweep time = auto.
6. Detector = RMS (i.e., power averaging), if available. Otherwise, use sample detector mode.
7. If transmit duty cycle < 98 %, use a sweep trigger with the level set to enable triggering only on full power pulses. The transmitter shall operate at maximum power control level for the entire duration of every sweep. If the EUT transmits continuously (i.e., with no off intervals) or at duty cycle \geq 98 %, and if each transmission is entirely at the maximum power control level, then the trigger shall be set to “free run”.
8. Trace average at least 100 traces in power averaging (i.e., RMS) mode.
9. Compute power by integrating the spectrum across the OBW of the signal using the instrument’s band power measurement function, with band limits set equal to the OBW band edges. If the instrument does not have a band power function, sum the spectrum levels (in power units) at intervals equal to the RBW extending across the entire OBW of the spectrum.

Test Result: Pass.

Please refer to the following tables and plots.

The Peak Power

Channel	Channel Frequency (MHz)	Data Rate (Mbps)	PK Output Power (dBm)	AV Output Power (dBm)	Limit (dBm)
802.11b mode					
Low	2412	1	11.90	8.88	30
Middle	2437	1	10.94	7.91	30
High	2462	1	10.25	7.39	30
802.11g mode					
Low	2412	6	11.31	5.92	30
Middle	2437	6	10.19	4.78	30
High	2462	6	9.54	4.09	30
802.11n mode					
Low	2412	MCS0	11.39	5.73	30
Middle	2437	MCS0	10.27	4.85	30
High	2462	MCS0	9.62	4.14	30

The Peak Power :

802.11b Low Channel

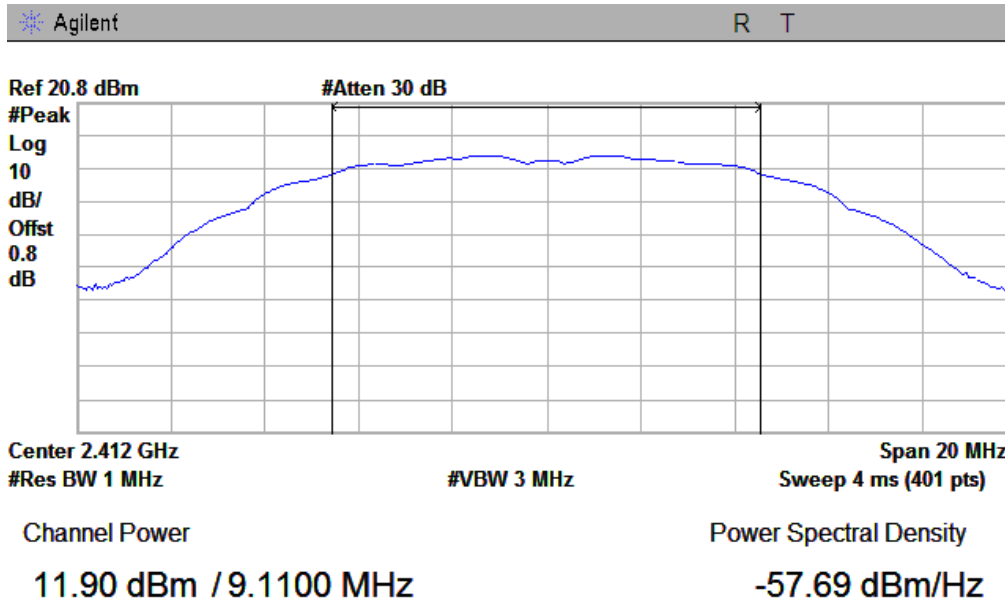

802.11b Middle Channel

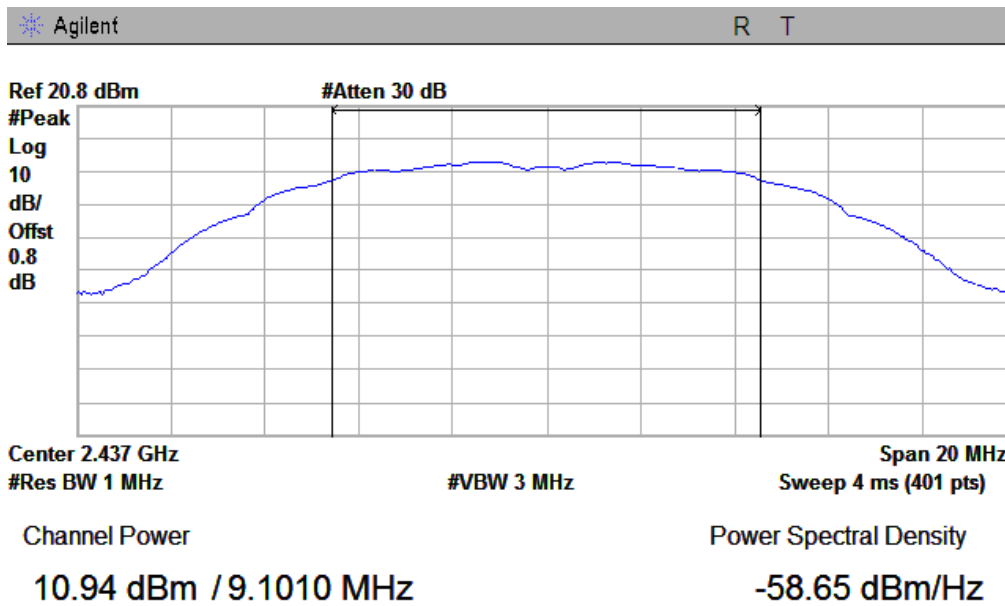



SIEMIC, INC.

Accessing global markets

Title: RF Test Report for Mobile Phone
Main Model: S470
Serial Model: N/A
To: FCC Part 15.247: 2012, ANSI C63.4: 2009

Report No.: 13070170-FCC-R4
Issue Date: July 26, 2013
Page: 25 of 73
www.siemic.com.cn

802.11b High Channel

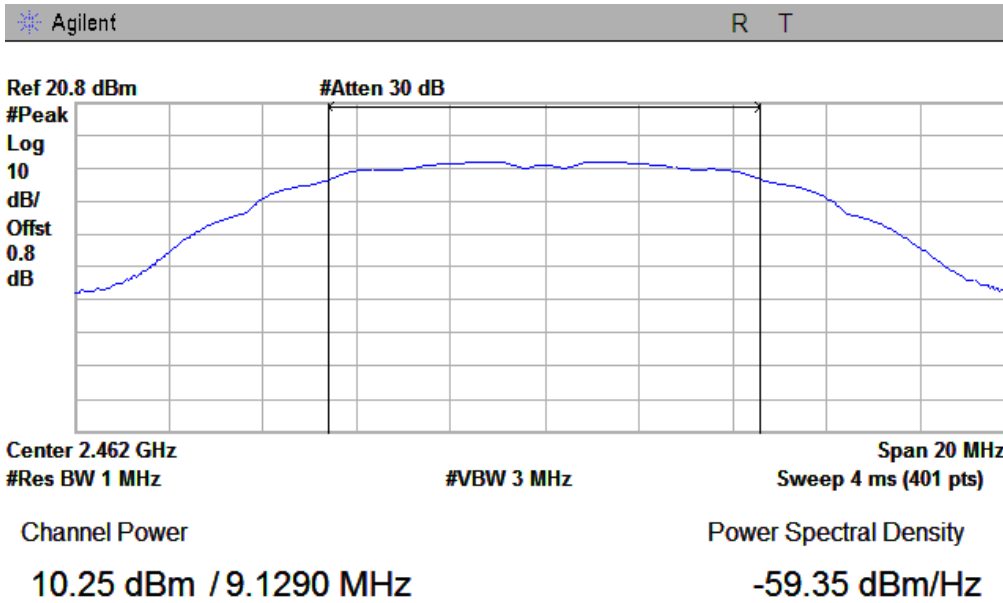

802.11g Low Channel

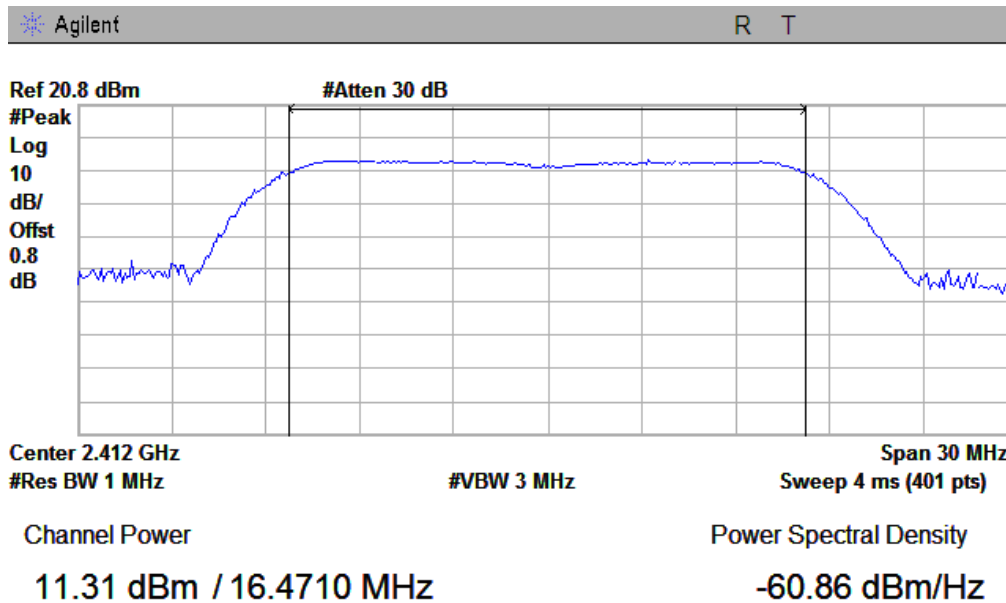



SIEMIC, INC.

Accessing global markets

Title: RF Test Report for Mobile Phone
Main Model: S470
Serial Model: N/A
To: FCC Part 15.247: 2012, ANSI C63.4: 2009

Report No.: 13070170-FCC-R4
Issue Date: July 26, 2013
Page: 26 of 73
www.siemic.com.cn

802.11g Middle Channel

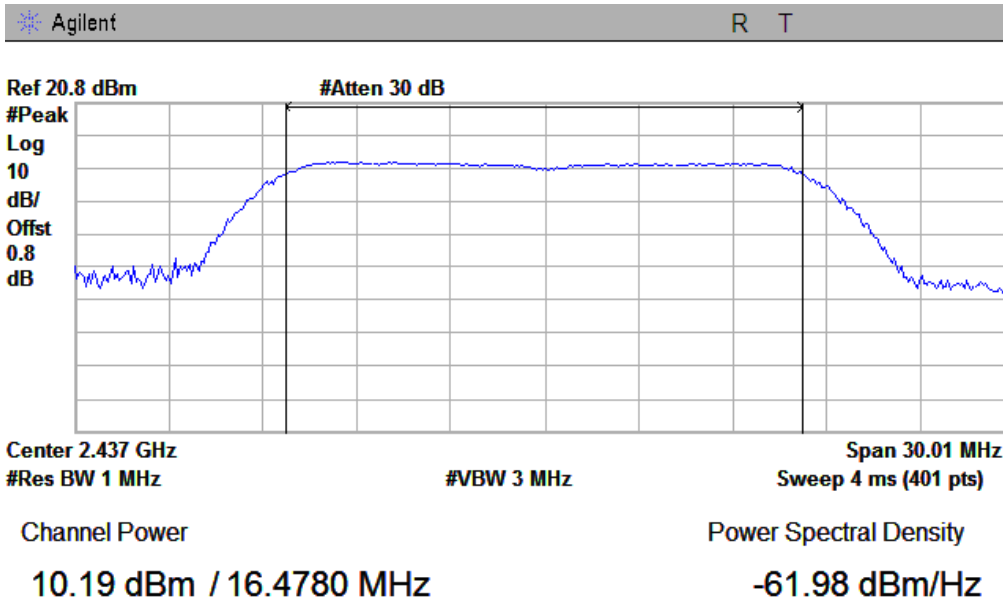

802.11g High Channel

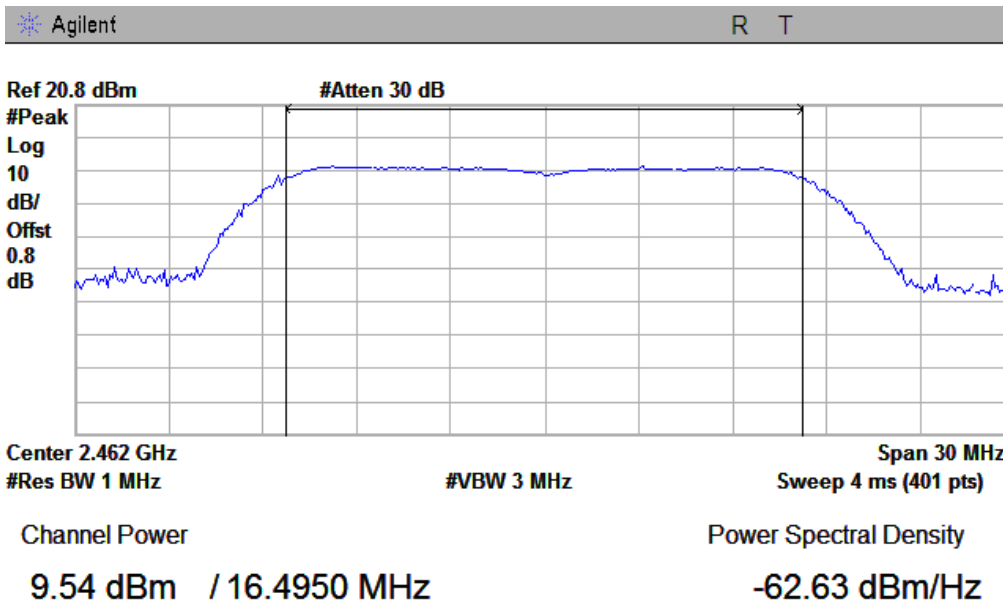

802.11n Low Channel

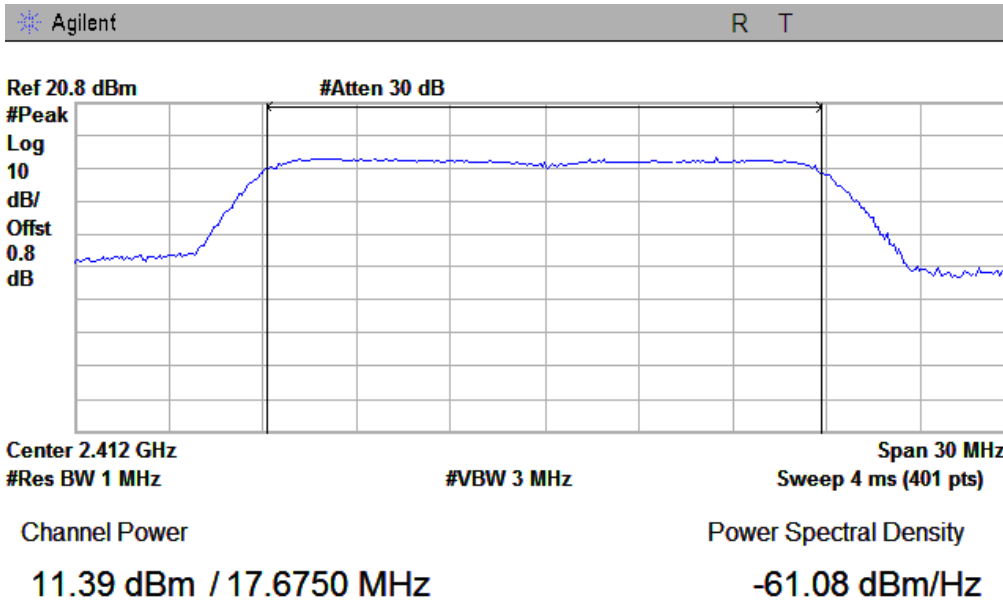

802.11n Middle Channel

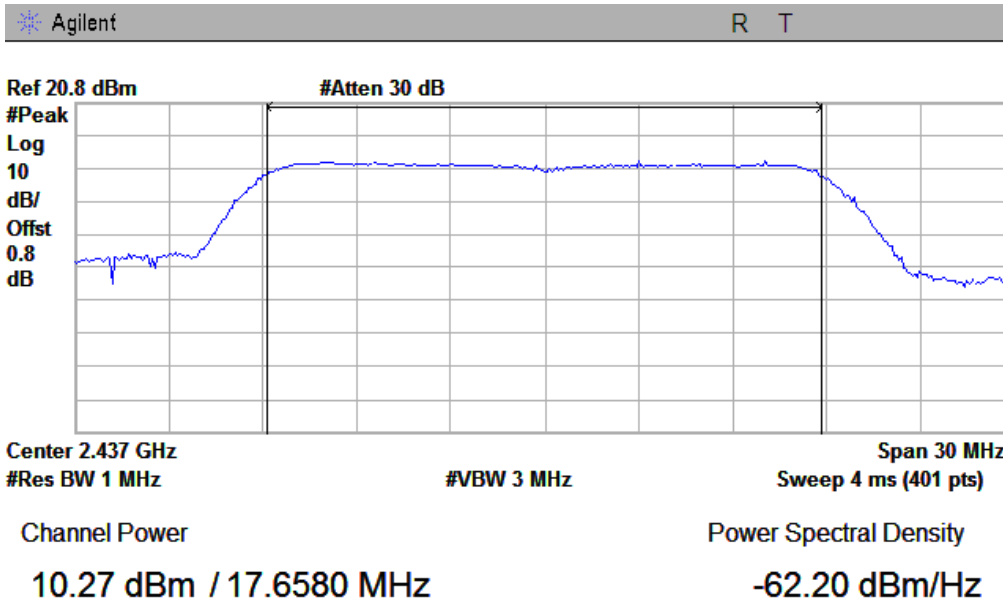

802.11n High Channel

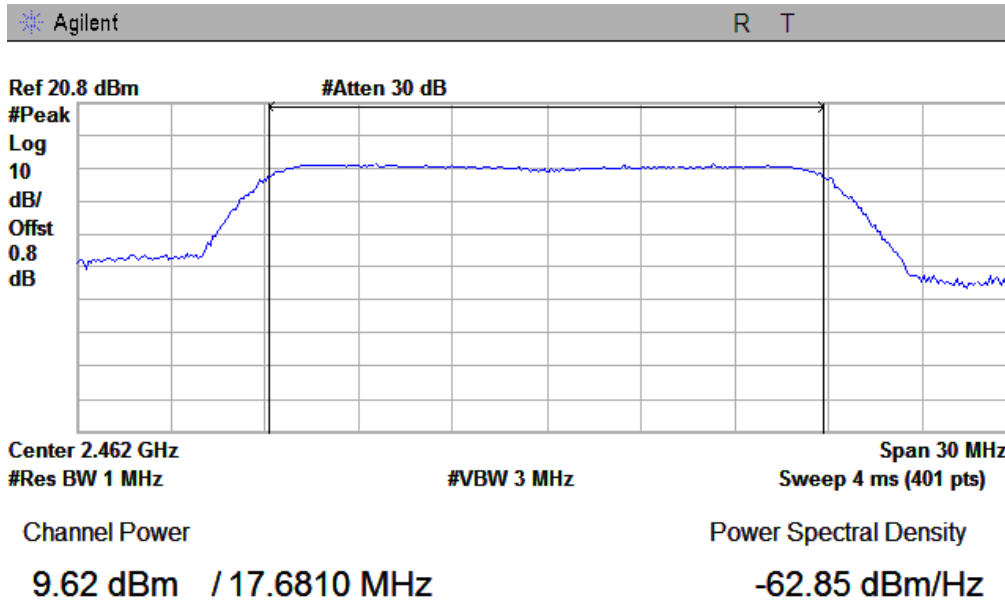

The Average Power:

802.11b Low Channel

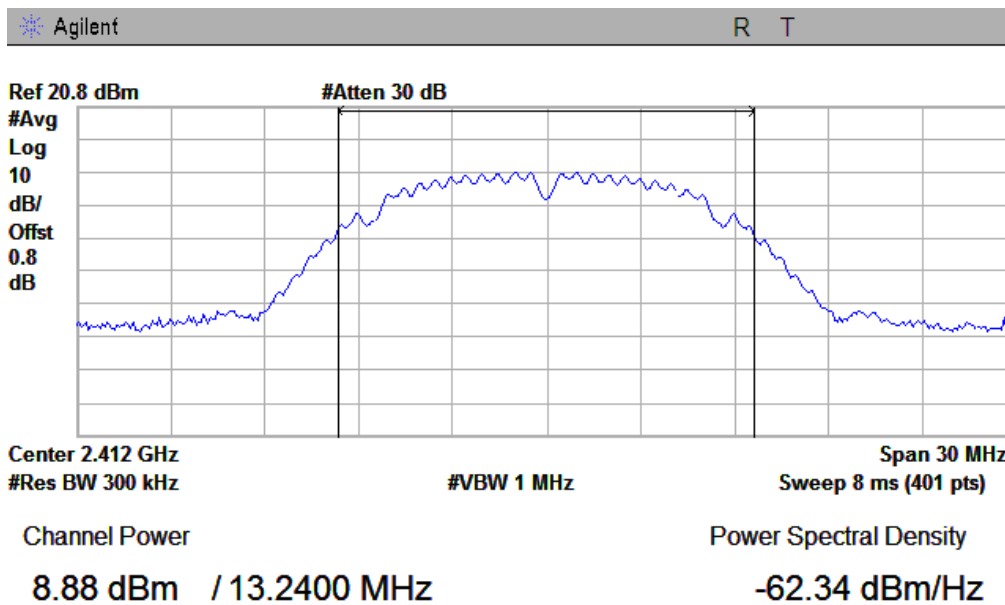



SIEMIC, INC.

Accessing global markets

Title: RF Test Report for Mobile Phone
Main Model: S470
Serial Model: N/A
To: FCC Part 15.247: 2012, ANSI C63.4: 2009

Report No.: 13070170-FCC-R4
Issue Date: July 26, 2013
Page: 29 of 73
www.siemic.com.cn

802.11b Middle Channel

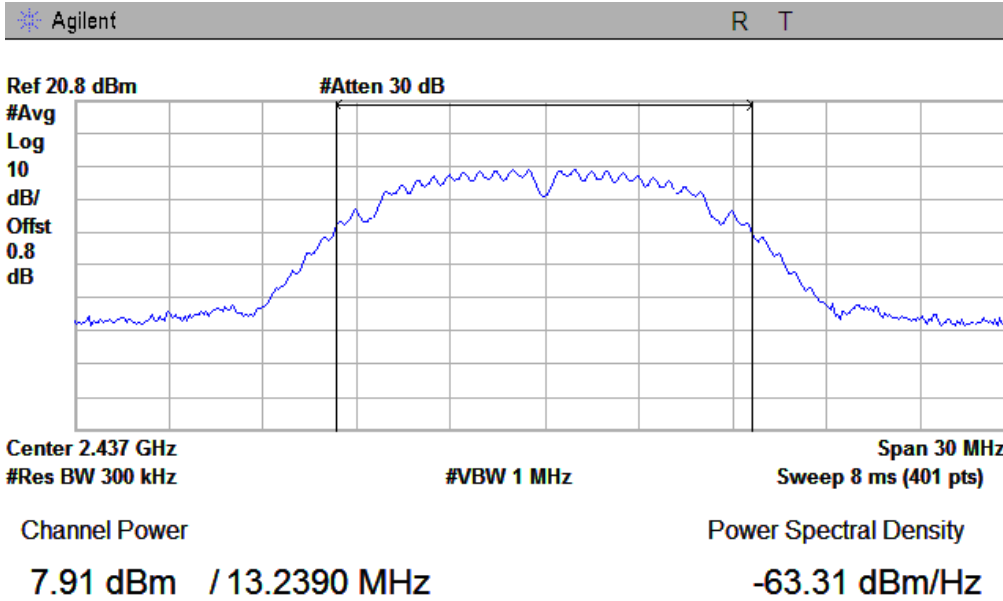

802.11b High Channel

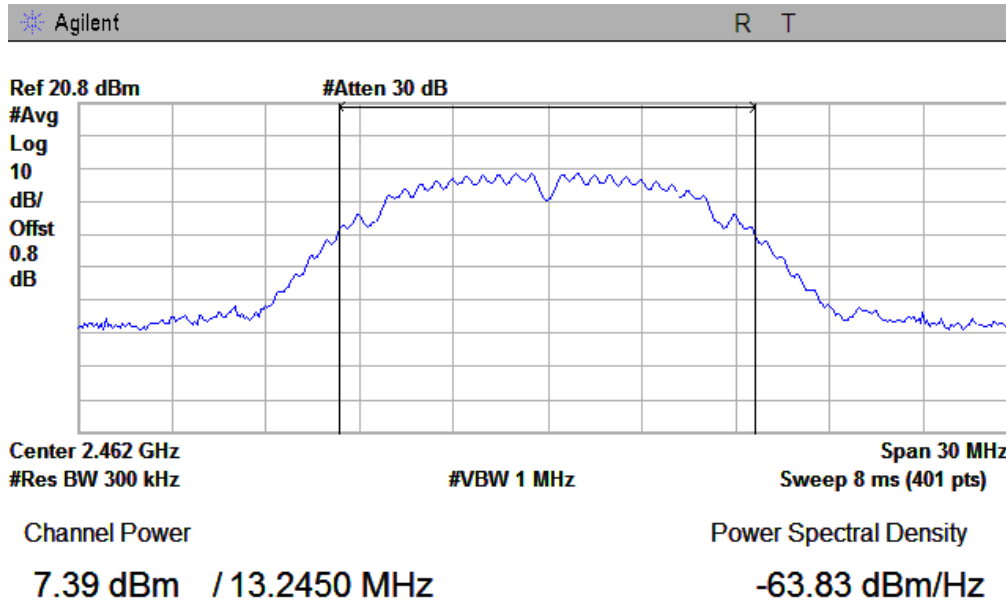

802.11g Low Channel

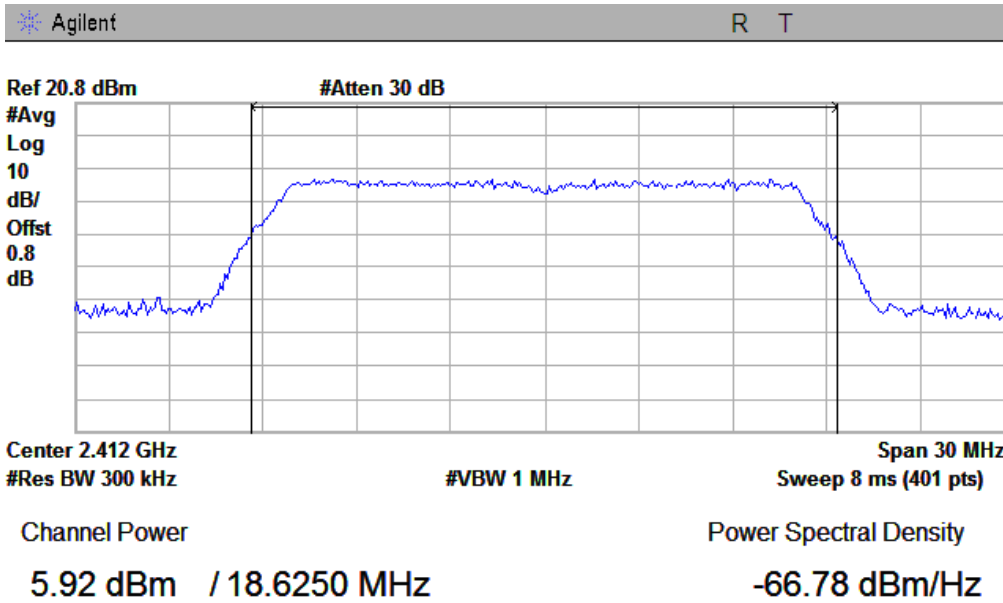

802.11g Middle Channel

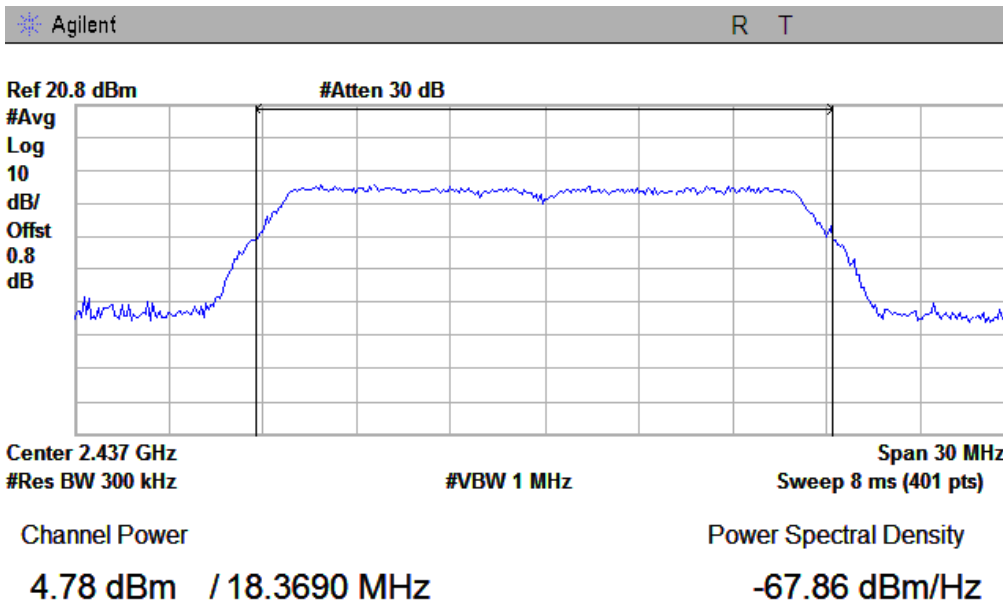

802.11g High Channel

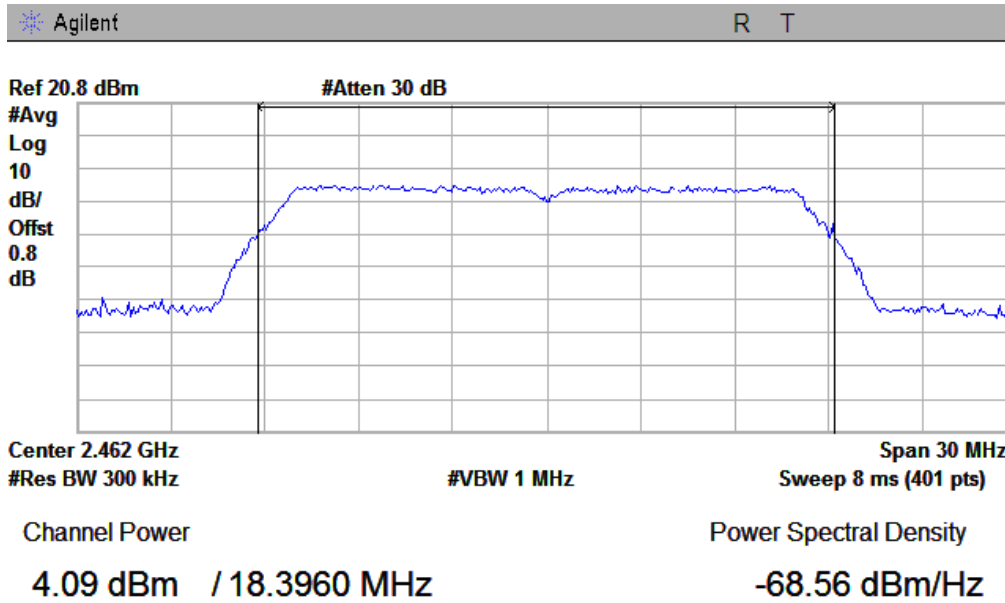

802.11n Low Channel

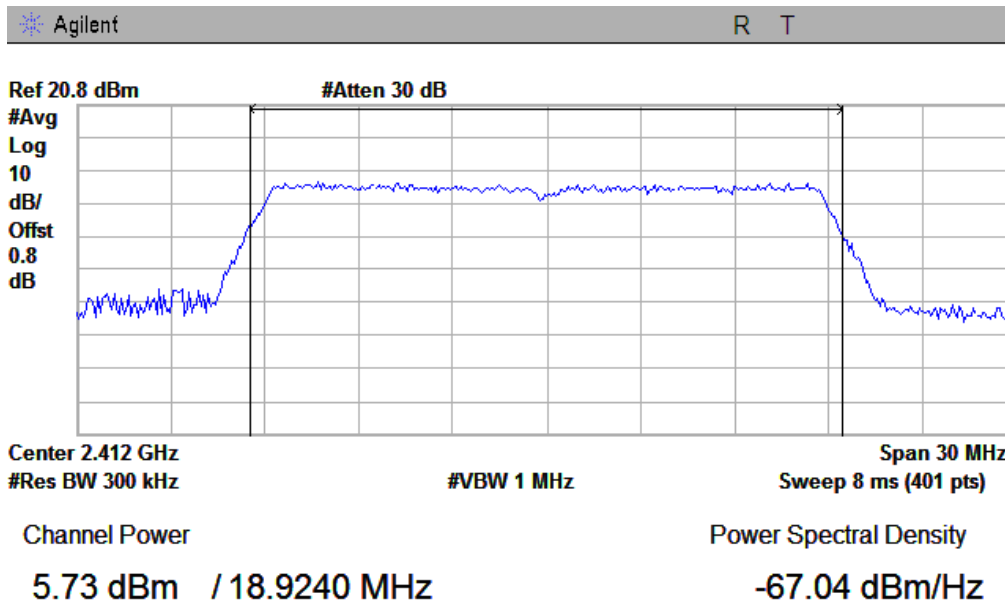

802.11n Middle Channel

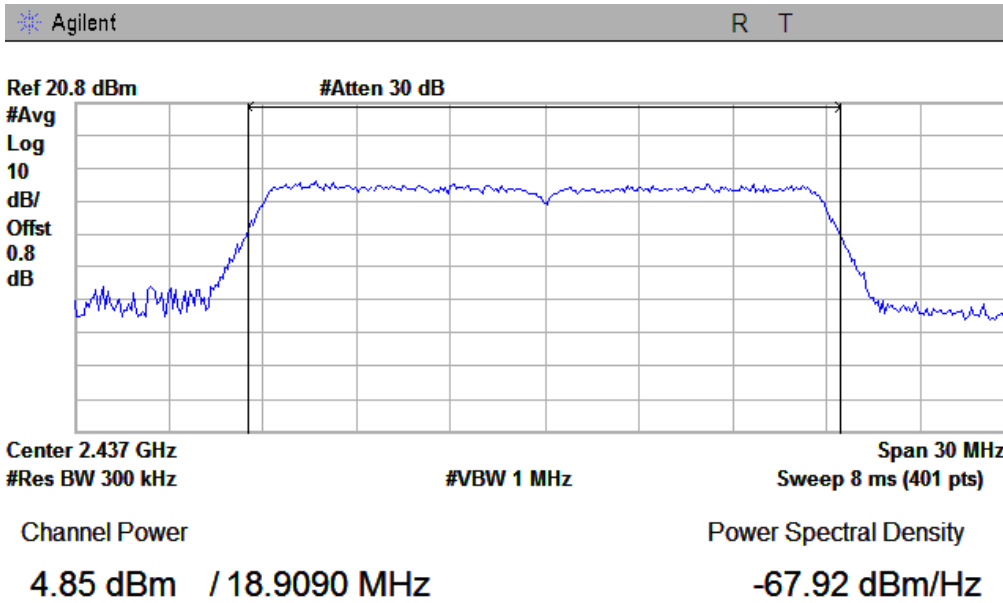

802.11n High Channel

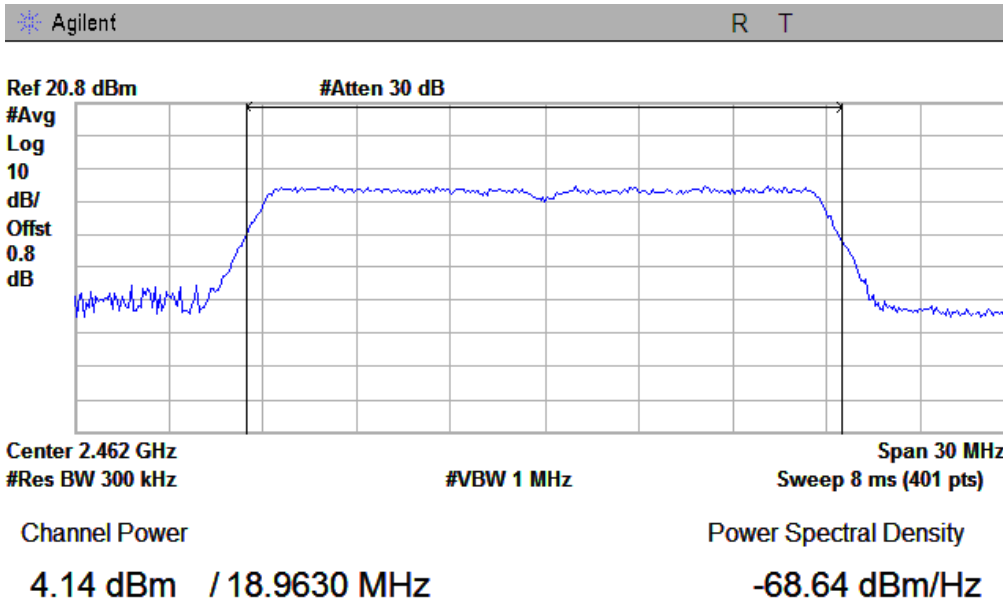

5.5 §15.247(e) - Power Spectral Density

1. **Conducted Measurement**
 EUT was set for low, mid, high channel with modulated mode and highest RF output power.
 The spectrum analyzer was connected to the antenna terminal.
2. **Environmental Conditions**

Temperature	26°C
Relative Humidity	58%
Atmospheric Pressure	1019mbar
3. **Conducted Emissions Measurement Uncertainty**
 All test measurements carried out are traceable to national standards. The uncertainty of the measurement at a confidence level of approximately 95% (in the case where distributions are normal), with a coverage factor of 2, in the range 30MHz – 40GHz is ±1.5dB.
4. **Test date :** July 22, 2013
Tested By : Back Huang

Requirement(s):

A conducted power spectral density (PSD) limit of 8 dBm in any 3 kHz band segment within the DTS bandwidth is specified during any time interval of continuous transmission. By rule, the same method as used to determine the conducted output power shall be used to determine the power spectral density (i.e., if maximum peak conducted output power was measured then the peak PSD procedure shall be used and if maximum conducted output power was measured then the average PSD procedure shall be used).

If the average PSD is measured with a power averaging (RMS) detector or a sample detector, then the spectrum analyzer must be capable of utilizing a number of measurement points in each sweep that is greater than or equal to twice the span/RBW in order to ensure bin-to-bin spacing of $\leq RBW/2$ so that narrowband signals are not lost between frequency bins.

Procedures:

This procedure must be used if maximum peak conducted output power was used to demonstrate compliance to the fundamental output power limit, and is optional if the maximum (average) conducted output power was used to demonstrate compliance.

1. Set analyzer center frequency to DTS channel center frequency.
2. Set the span to 1.5 times the DTS channel bandwidth.
3. Set the RBW ≥ 3 kHz.
4. Set the VBW $\geq 3 \times$ RBW.
5. Detector = peak.
6. Sweep time = auto couple.
7. Trace mode = max hold.
8. Allow trace to fully stabilize.
9. Use the peak marker function to determine the maximum amplitude level.
10. If measured value exceeds limit, reduce RBW (no less than 3 kHz) and repeat.

Test Result: Pass.

Please refer to the following tables and plots.

Channel	Frequency (MHz)	Data Rate	PSD (dBm)	Limit (dBm)
802.11b mode				
Low	2412	1	0.315	8
Middle	2437	1	-0.275	8
High	2462	1	-1.000	8
802.11g mode				
Low	2412	6	-4.573	8
Middle	2437	6	-5.676	8
High	2462	6	-6.370	8
802.11n mode				
Low	2412	MCS0	-4.761	8
Middle	2437	MCS0	-5.638	8
High	2462	MCS0	-6.325	8

Power Spectral Density, 802.11b Low Channel

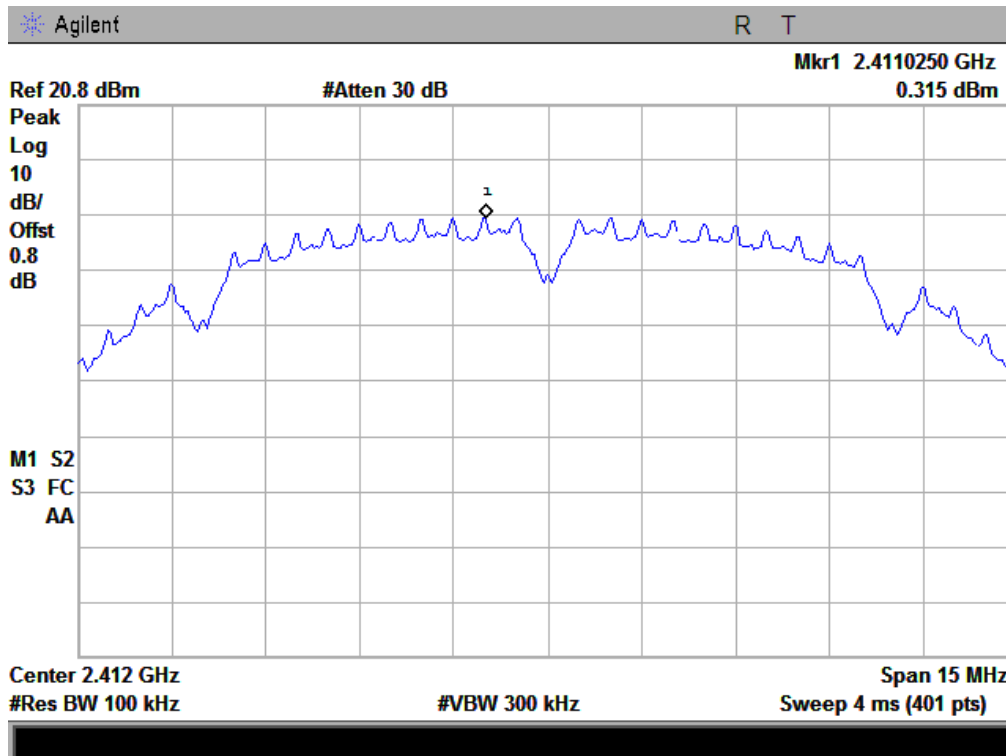

Power Spectral Density, 802.11b Middle Channel

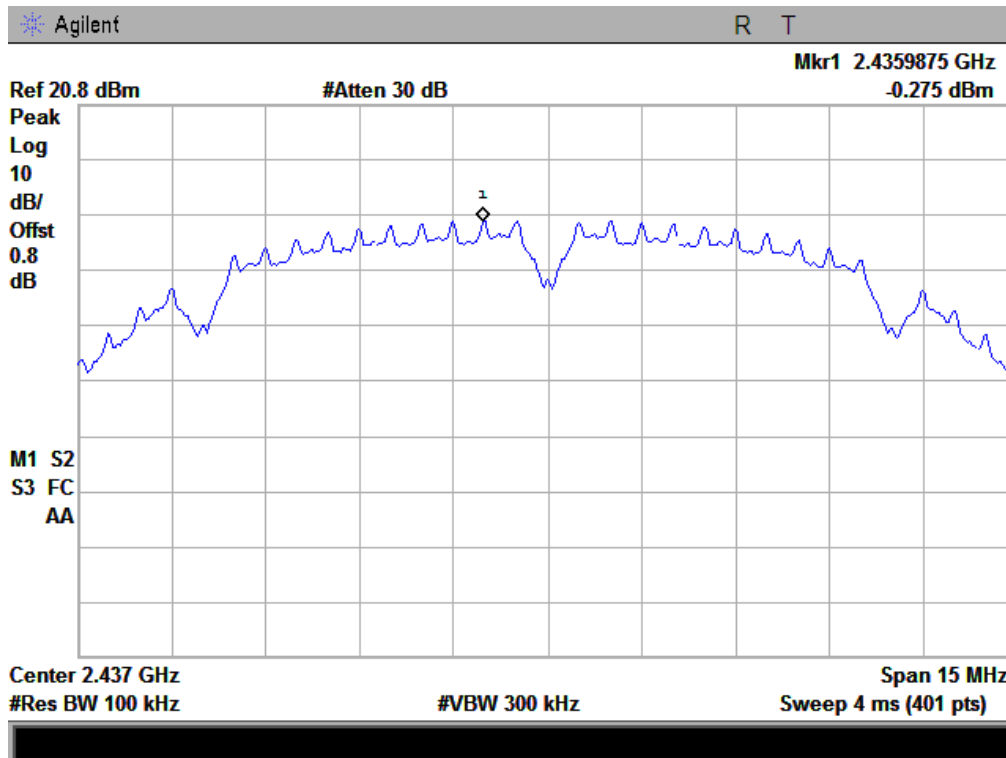

Power Spectral Density, 802.11b High Channel

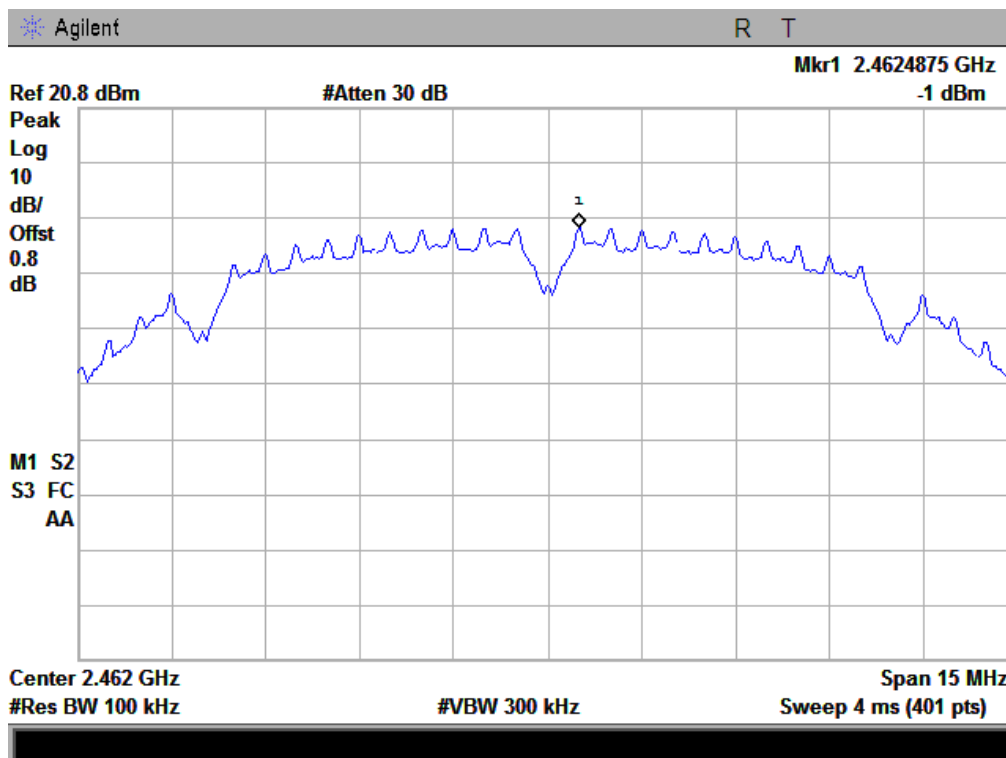



SIEMIC, INC.

Accessing global markets

Title: RF Test Report for Mobile Phone
Main Model: S470
Serial Model: N/A
To: FCC Part 15.247: 2012, ANSI C63.4: 2009

Report No.: 13070170-FCC-R4
Issue Date: July 26, 2013
Page: 36 of 73
www.siemic.com.cn

Power Spectral Density, 802.11g Low Channel

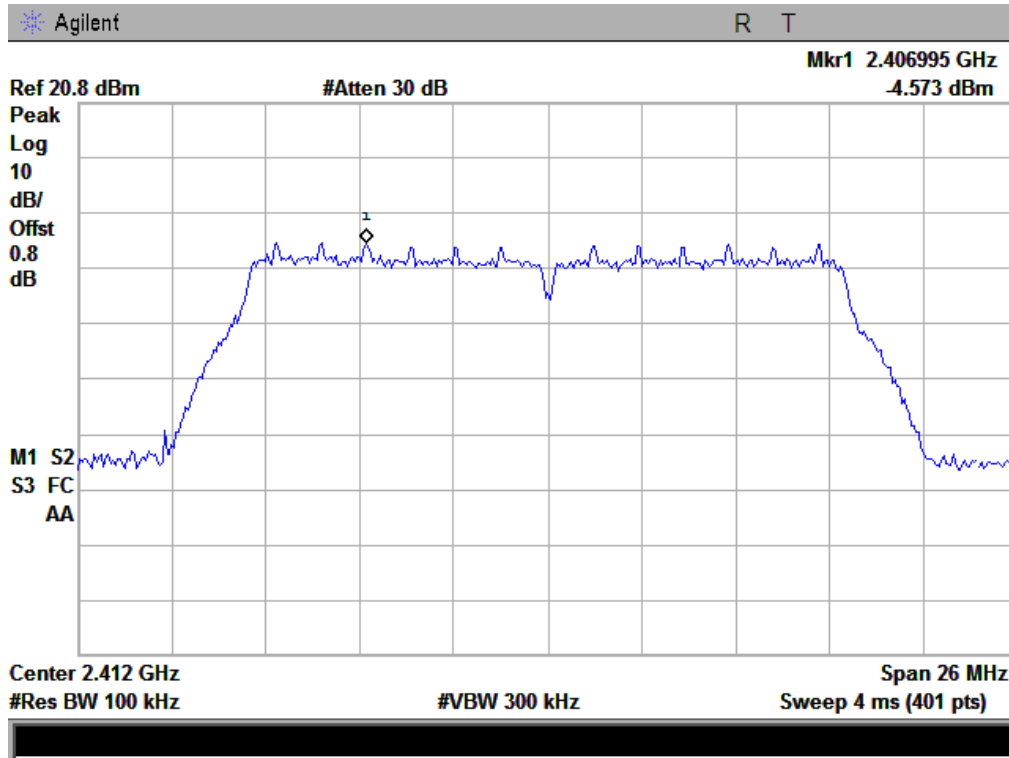

Power Spectral Density, 802.11g Middle Channel

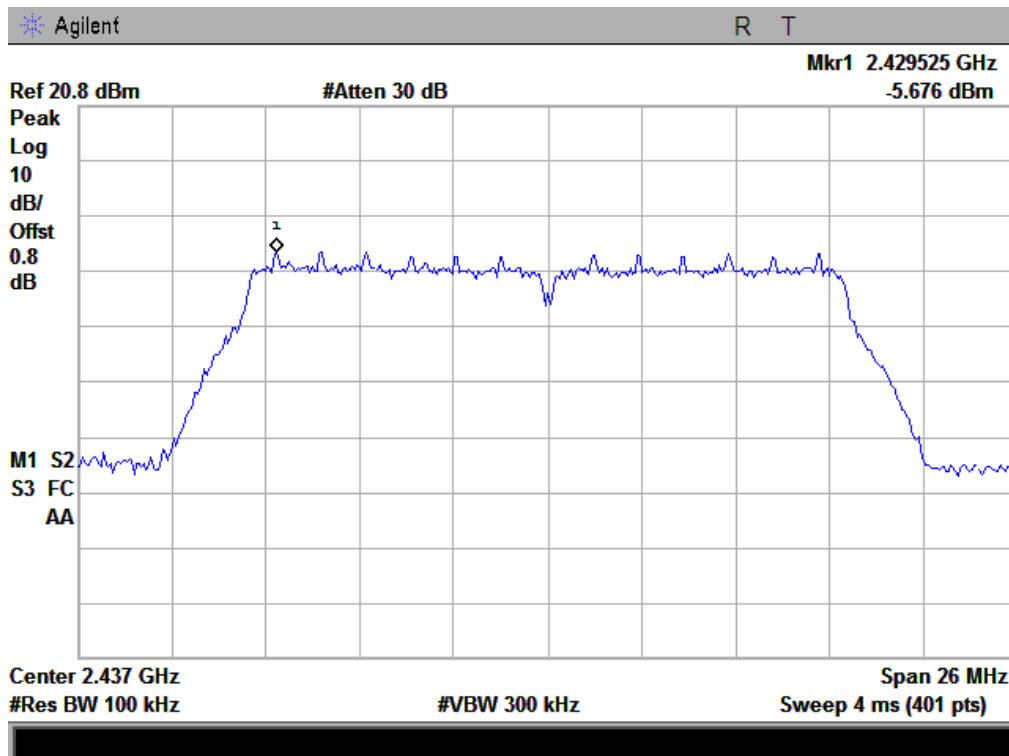



SIEMIC, INC.

Accessing global markets

Title: RF Test Report for Mobile Phone
Main Model: S470
Serial Model: N/A
To: FCC Part 15.247: 2012, ANSI C63.4: 2009

Report No.: 13070170-FCC-R4
Issue Date: July 26, 2013
Page: 37 of 73
www.siemic.com.cn

Power Spectral Density, 802.11g High Channel

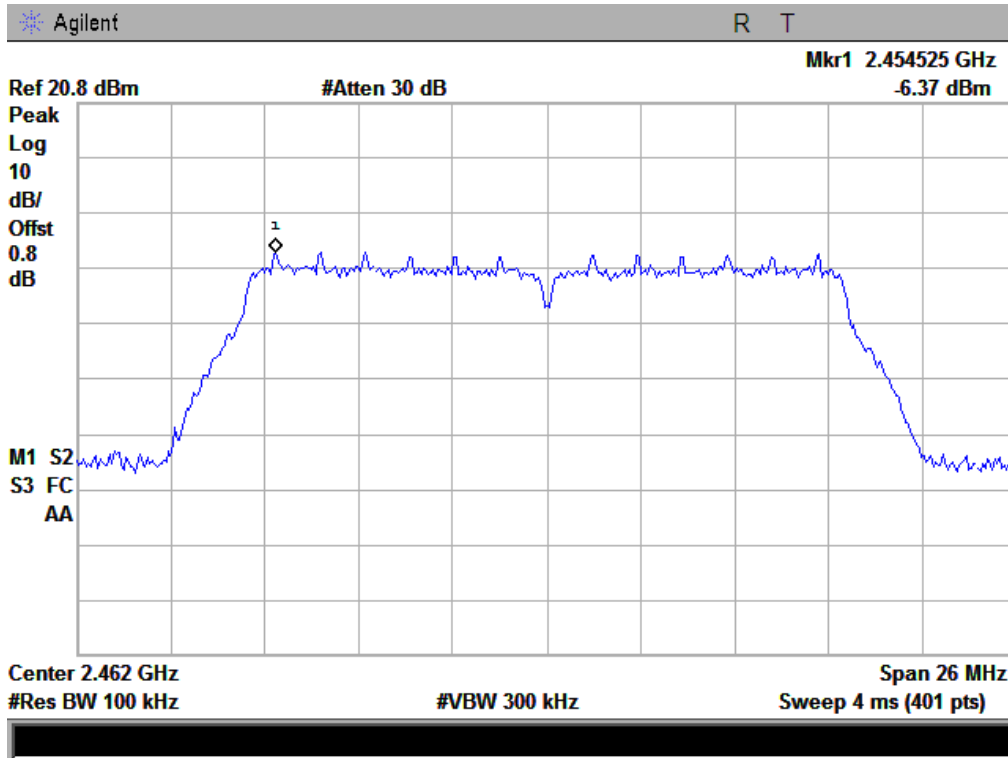

Power Spectral Density, 802.11n Low Channel

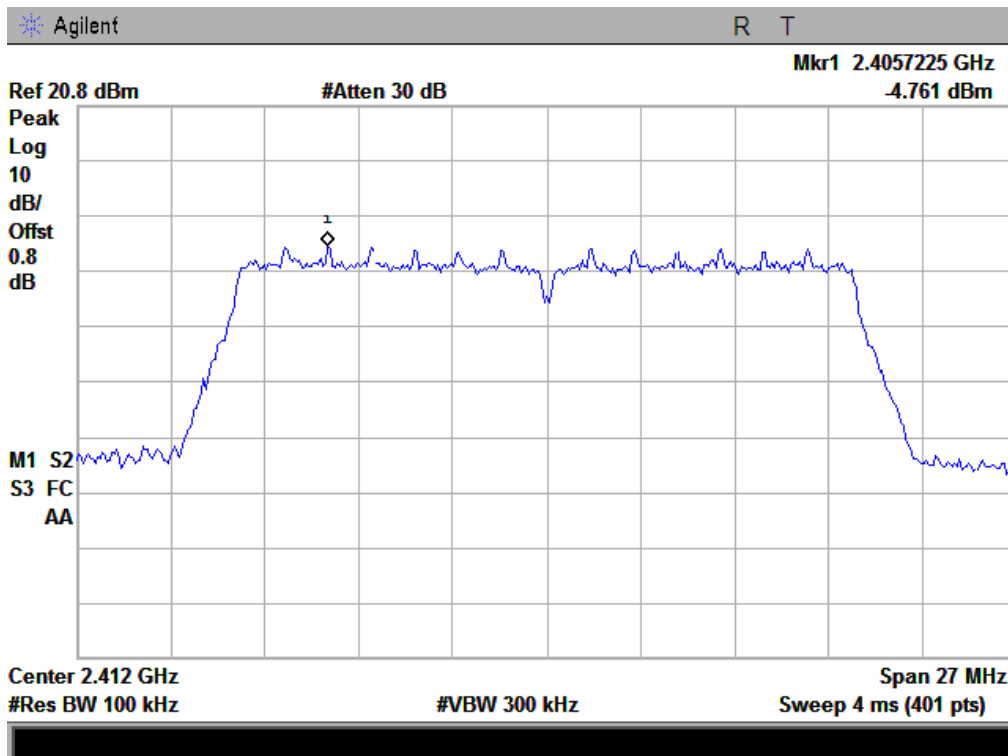

Power Spectral Density, 802.11n Middle Channel

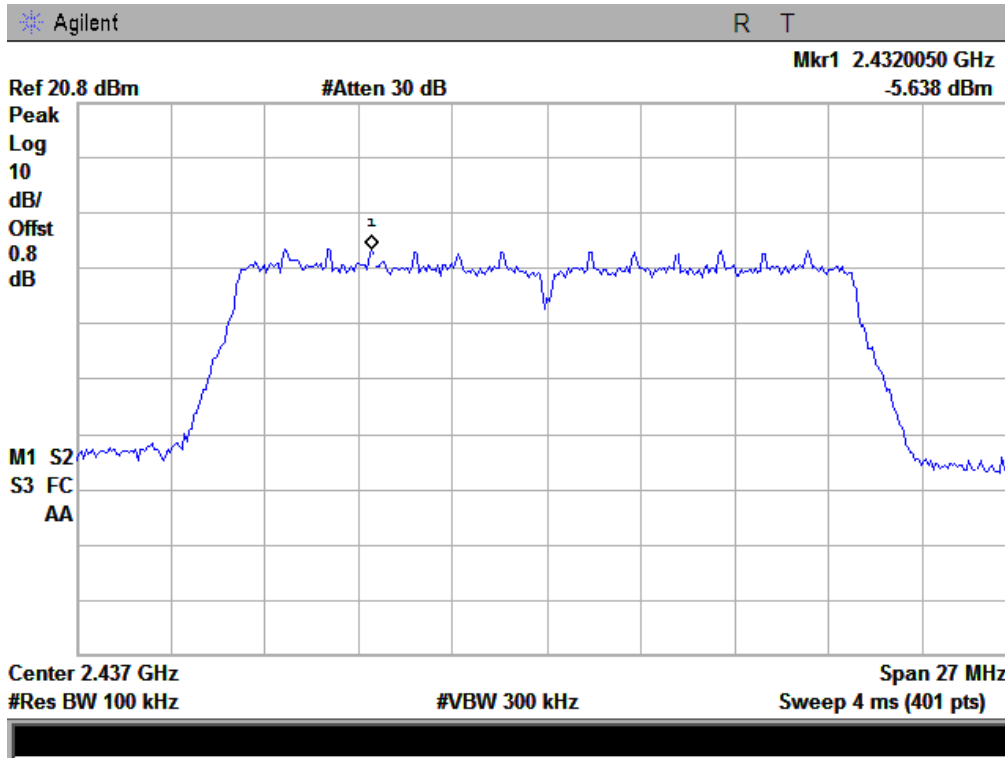

Power Spectral Density, 802.11n High Channel

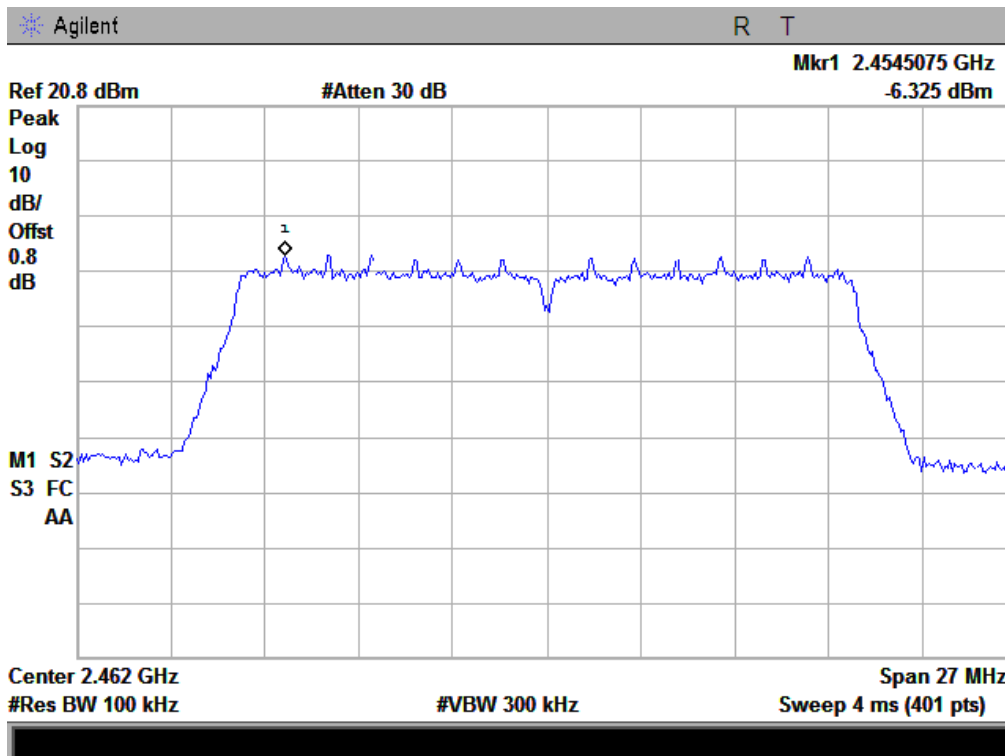

5.6 §15.247(d) –Band-Edge & Unwanted Emissions into Non-Restricted Frequency Bands

1. In any 100 kHz bandwidth outside the frequency band in which the spread spectrum or digitally modulated intentional radiator is operating, the radio frequency power that is produced by the intentional radiator shall be at least 20 dB below that in the 100 kHz bandwidth within the band that contains the highest level of the desired power, based on either an RF conducted or a radiated measurement, provided the transmitter demonstrates compliance with the peak conducted power limits. If the transmitter complies with the conducted power limits based on the use of RMS averaging over a time interval, as permitted under paragraph (b)(3) of this section, the attenuation required under this paragraph shall be 30 dB instead of 20 dB. Attenuation below the general limits specified in §15.209(a) is not required. In addition, radiated emissions which fall in the restricted bands, as defined in §15.205(a), must also comply with the radiated emission limits specified in §15.209(a) (see §15.205(c))

2.

Environmental Conditions	Temperature	26°C
	Relative Humidity	63%
	Atmospheric Pressure	1012mbar

3.

Test date : July 24, 2013
Tested By : Back Huang

Requirement(s):

Band-Edge Measurements

An additional consideration when performing conducted measurements of restricted band emissions is that unwanted emissions radiating from the EUT cabinet, control circuits, power leads, or intermediate circuit elements will likely go undetected in a conducted measurement configuration. To address this concern, a radiated test shall be performed to ensure that emissions emanating from the EUT cabinet (rather than the antenna port) also comply with the applicable limits.

For these cabinet radiated spurious emission measurements the EUT transmit antenna may be replaced with a termination matching the nominal impedance of the antenna. Procedures for performing radiated measurements are specified in ANSI C63.10. All detected emissions shall comply with the applicable limits.

Procedures: (Radiated Method Only)

1. Check the calibration of the measuring instrument using either an internal calibrator or a known signal from an external generator.
2. Position the EUT on the rotated table inside the anechoic chamber without connection to measurement instrument. Turn on the EUT and make it operate in transmitting mode. Then set it to Low Channel and High Channel within its operating range, and make sure the instrument is operated in its linear range. Repeat above procedures until all measured frequencies were complete.
3. Set band RBW=1MHz, VBW=3MHz with a convenient frequency span from band edge.
4. Find the highest point in edge frequency, and then calculated results.
5. Repeat above procedures until all measured frequencies were complete.

Test Result: Pass.

Please refer to the following tables and plots.

802.11b: Band Edge, Left Side (Average)

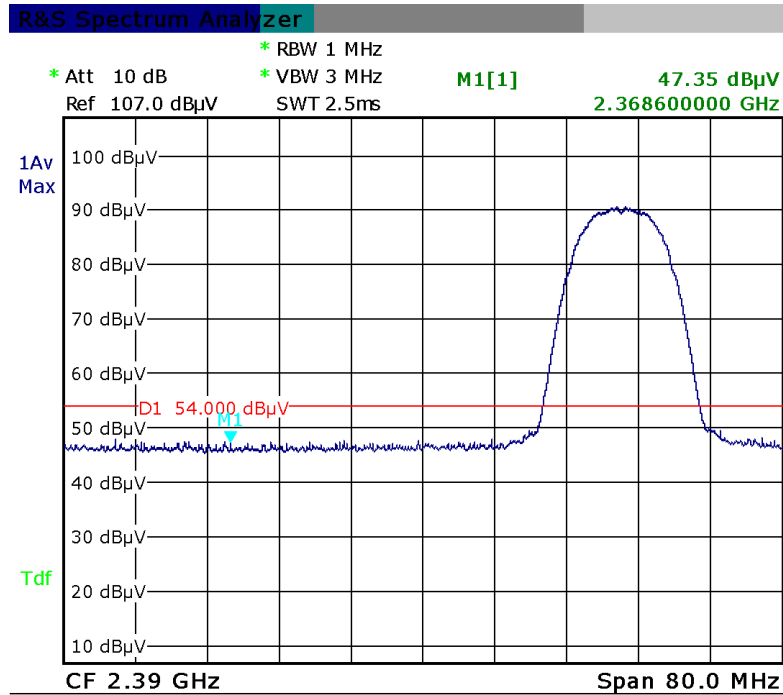

Date: 24.JUL.2013 05:12:25

802.11b: Band Edge, Left Side (Peak)

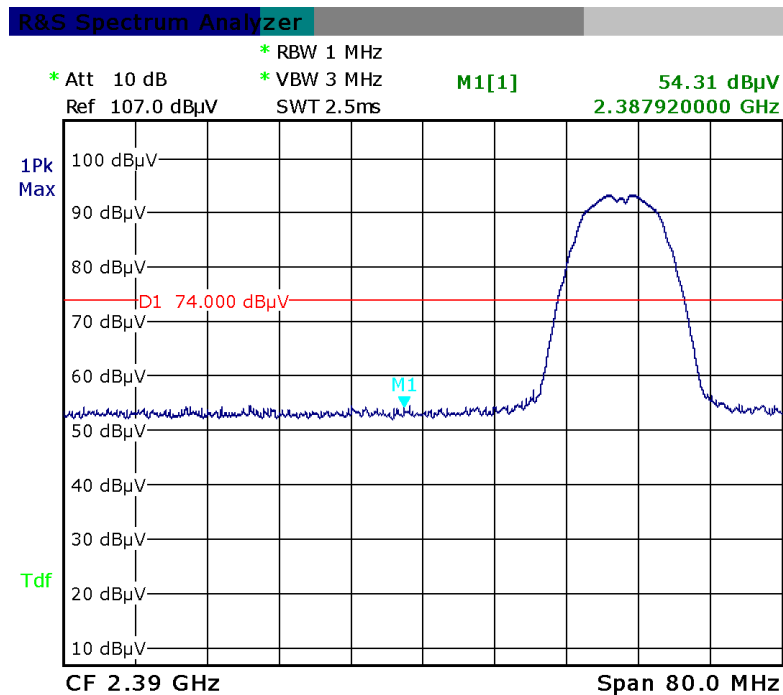

Date: 24.JUL.2013 05:10:42



SIEMIC, INC.

Accessing global markets

Title: RF Test Report for Mobile Phone
Main Model: S470
Serial Model: N/A
To: FCC Part 15.247: 2012, ANSI C63.4: 2009

Report No.: 13070170-FCC-R4
Issue Date: July 26, 2013
Page: 41 of 73
www.siemic.com.cn

802.11b: Band Edge, Right Side (Average)

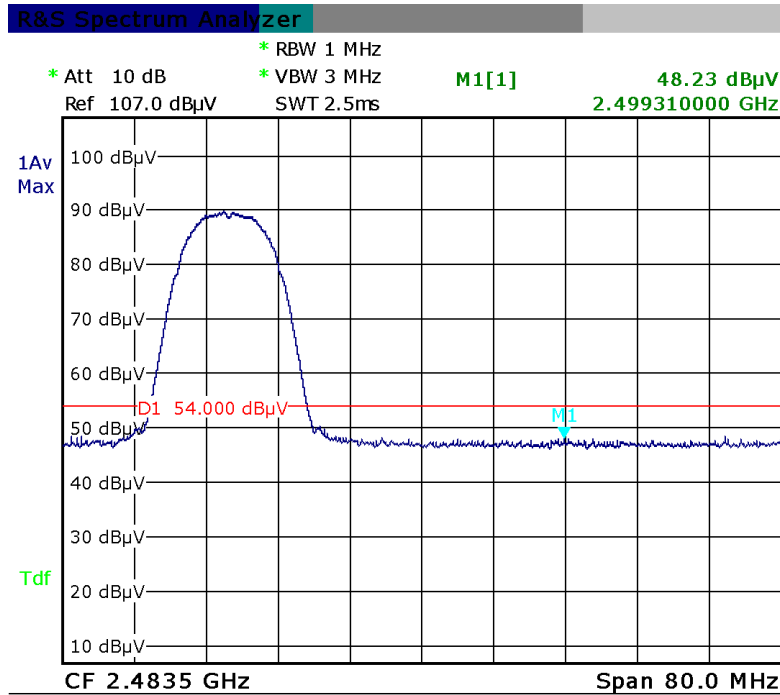

Date: 24.JUL.2013 05:26:02

802.11b: Band Edge, Right Side (Peak)

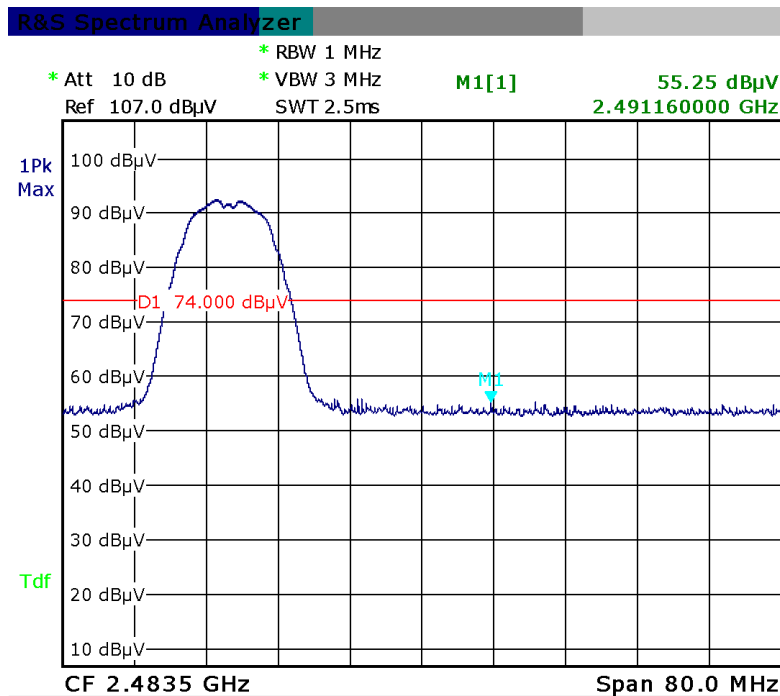

Date: 24.JUL.2013 05:27:44

802.11g: Band Edge, Left Side (Average)

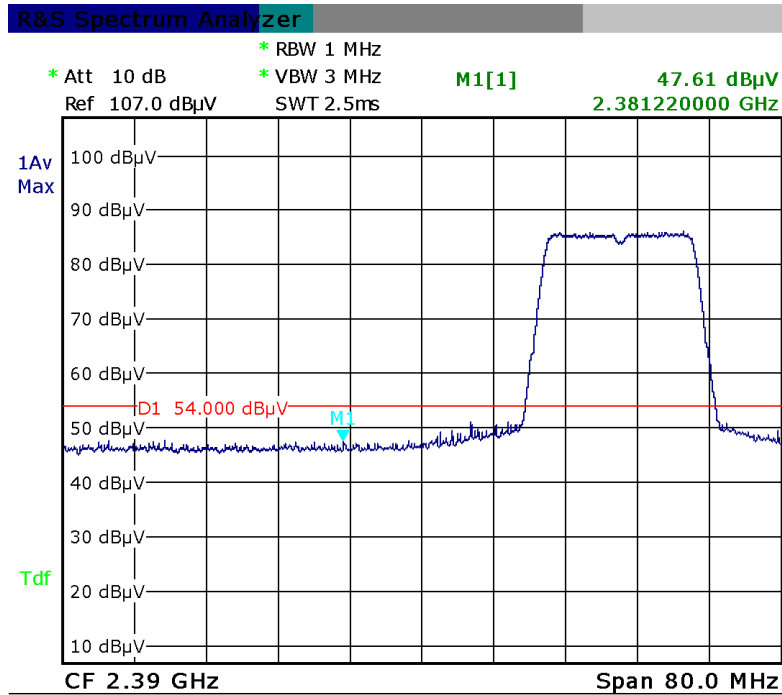

Date: 24.JUL.2013 05:15:05

802.11g: Band Edge, Left Side (Peak)

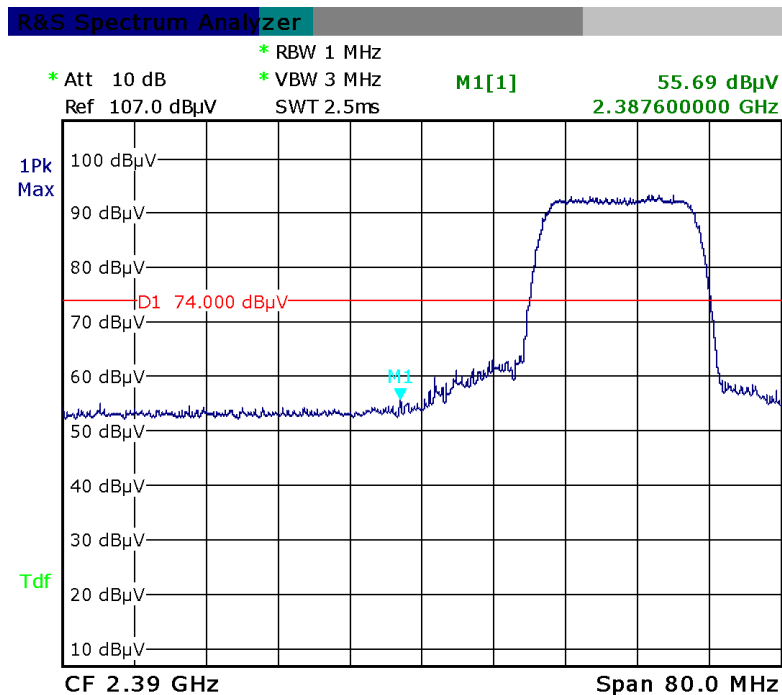

Date: 24.JUL.2013 05:16:26

802.11g: Band Edge, Right Side (Average)

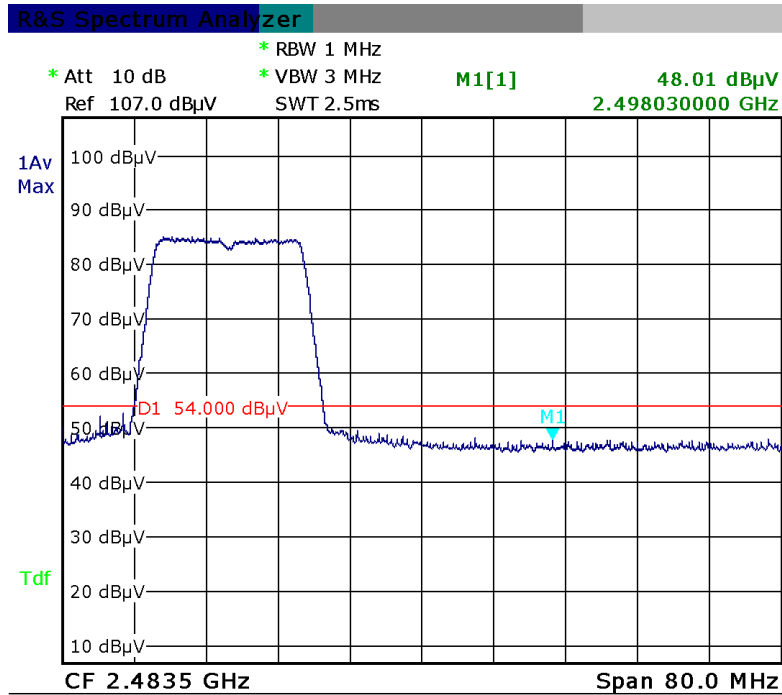

Date: 24.JUL.2013 05:32:00

802.11g: Band Edge, Right Side (Peak)

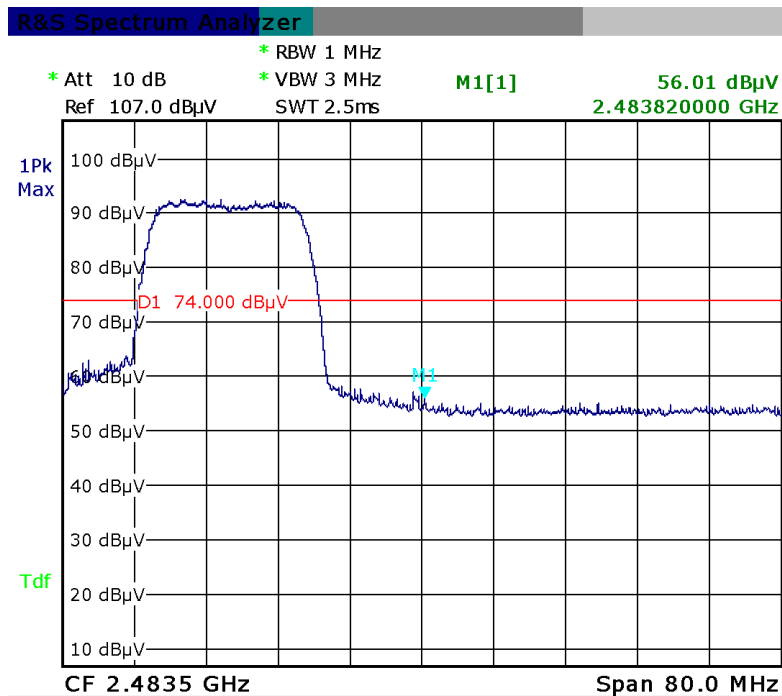

Date: 24.JUL.2013 05:31:04



SIEMIC, INC.

Accessing global markets

Title: RF Test Report for Mobile Phone
Main Model: S470
Serial Model: N/A
To: FCC Part 15.247: 2012, ANSI C63.4: 2009

Report No.: 13070170-FCC-R4
Issue Date: July 26, 2013
Page: 44 of 73
www.siemic.com.cn

802.11n: Band Edge, Left Side (Average)

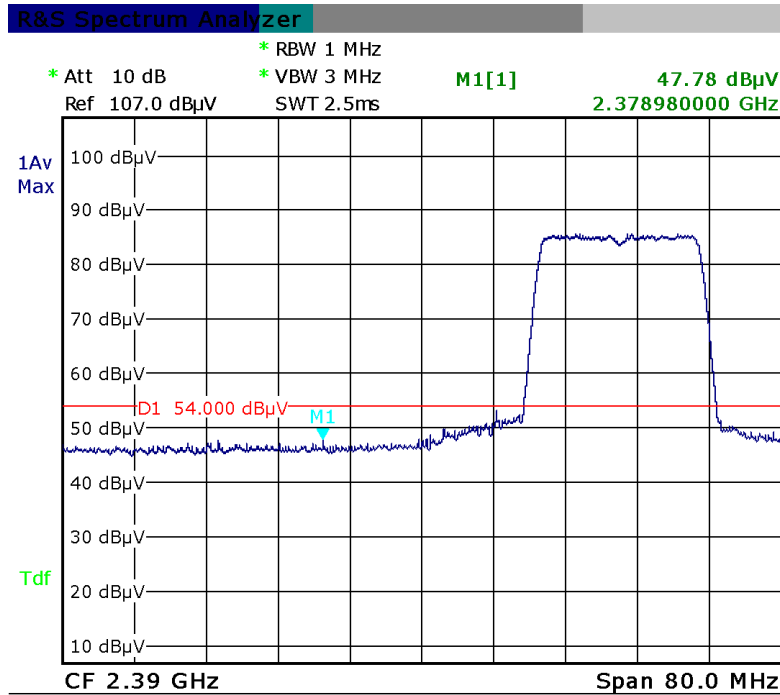

Date: 24.JUL.2013 05:21:13

802.11n: Band Edge, Left Side (Peak)

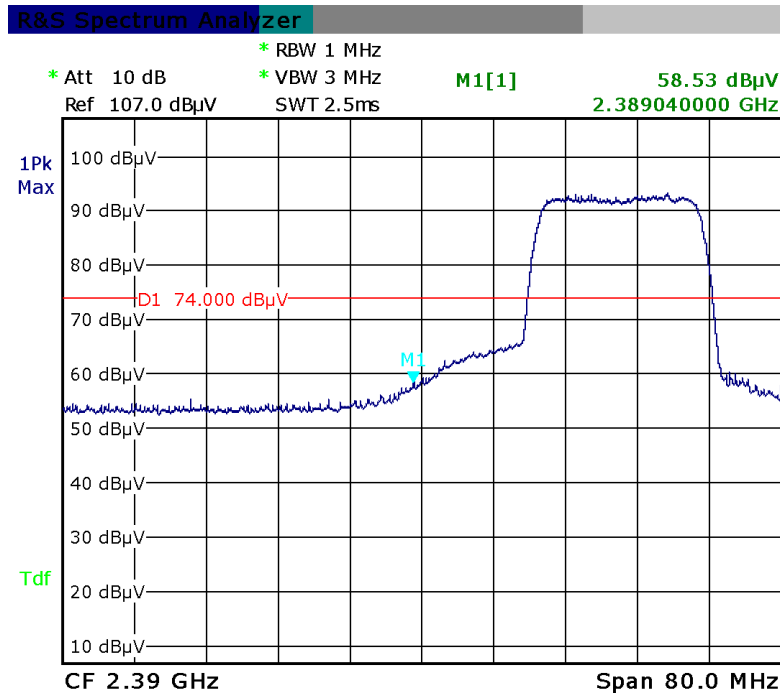

Date: 24.JUL.2013 05:19:54

802.11n: Band Edge, Right Side (Average)

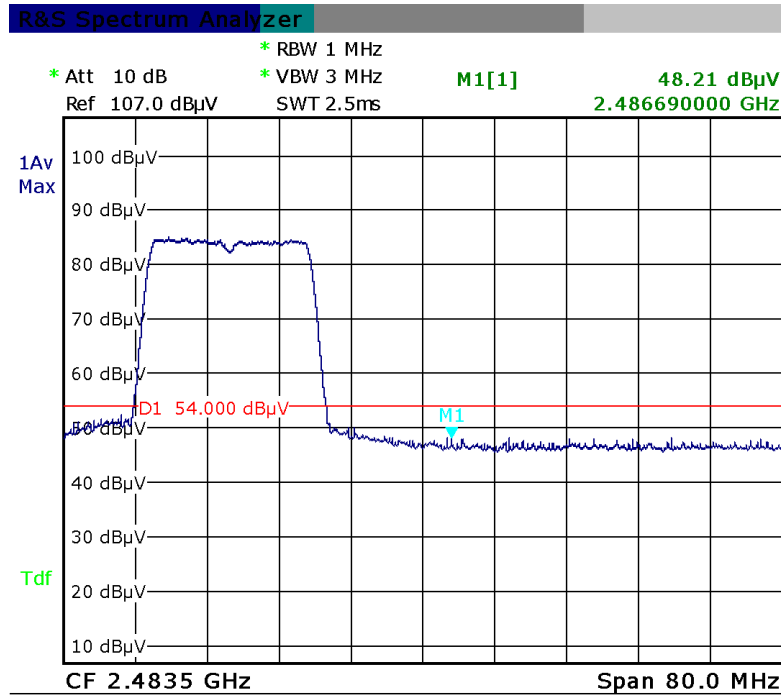

Date: 24.JUL.2013 05:34:37

802.11n: Band Edge, Right Side (Peak)

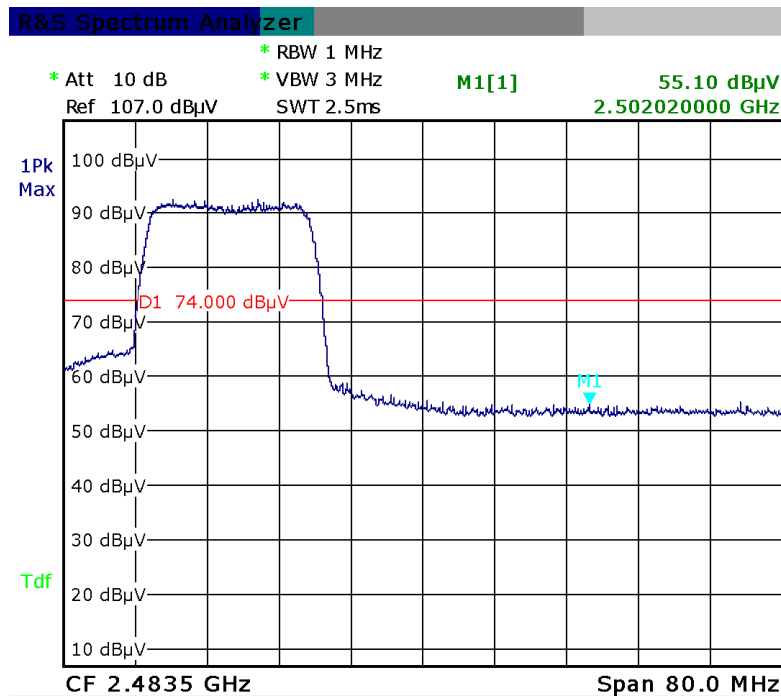

Date: 24.JUL.2013 05:36:02

5.7 §15.207 (a) - AC Power Line Conducted Emissions

Requirement:

Frequency of emission (MHz)	Conducted limit (dBμV)	
	Quasi-peak	Average
0.15–0.5	66 to 56*	56 to 46*
0.5–5	56	46
5–30	60	50

*Decreases with the logarithm of the frequency.

Procedures:

- All possible modes of operation were investigated. Only the 6 worst case emissions measured, using the correct CISPR and Average detectors, are reported. All other emissions were relatively insignificant.
- A "-ve" margin indicates a PASS as it refers to the margin present below the limit line at the particular frequency.
- Conducted Emissions Measurement Uncertainty
All test measurements carried out are traceable to national standards. The uncertainty of the measurement at a confidence level of approximately 95% (in the case where distributions are normal), with a coverage factor of 2, in the range 9kHz – 30MHz (Average & Quasi-peak) is ±3.5dB.
- Environmental Conditions

Temperature	27°C
Relative Humidity	68%
Atmospheric Pressure	1018mbar
- Test date: July 23, 2013
Tested By : Back Huang

Test Mode:	Transmitting Mode(Worse Case)
-------------------	--------------------------------------

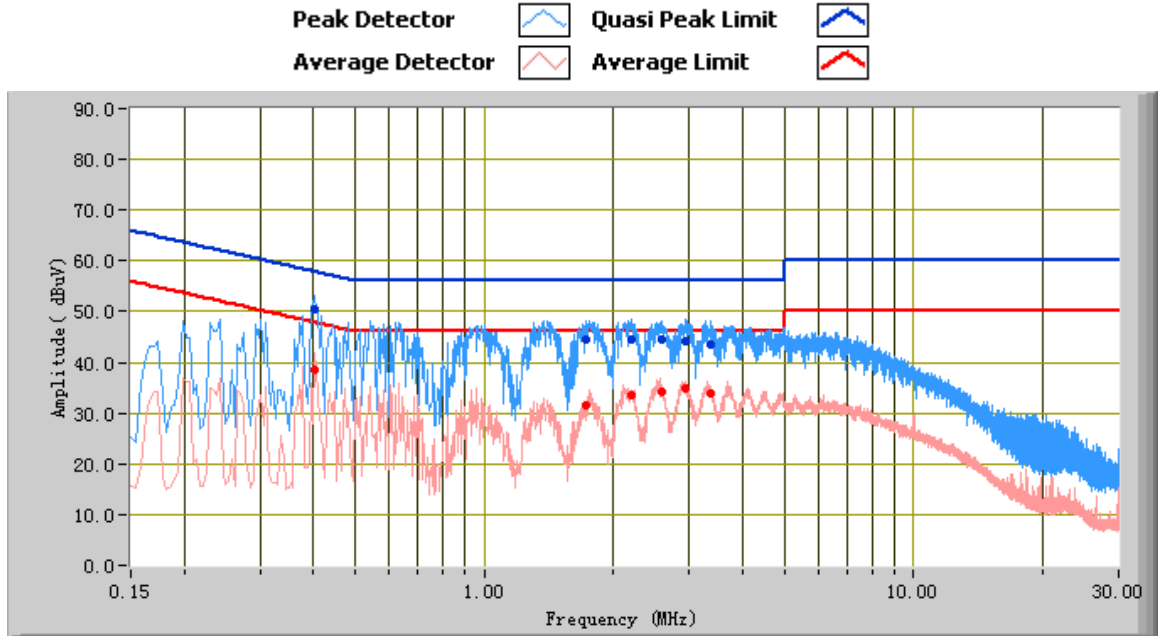

Test Data

Phase Line Plot at 120Vac, 60Hz

Frequency (MHz)	Quasi Peak (dBµV)	Limit (dBµV)	Margin (dB)	Average (dBµV)	Limit (dBµV)	Margin (dB)	Factors (dB)
0.40	50.36	57.81	-7.45	38.63	47.81	-9.18	11.23
2.21	44.48	56.00	-11.52	33.40	46.00	-12.60	10.88
2.95	44.09	56.00	-11.91	34.92	46.00	-11.08	10.88
1.72	44.41	56.00	-11.59	31.71	46.00	-14.29	10.82
3.37	43.58	56.00	-12.42	33.87	46.00	-12.13	10.88
2.58	44.34	56.00	-11.66	34.21	46.00	-11.79	10.88

Test Mode:	Transmitting Mode(Worse Case)
-------------------	--------------------------------------

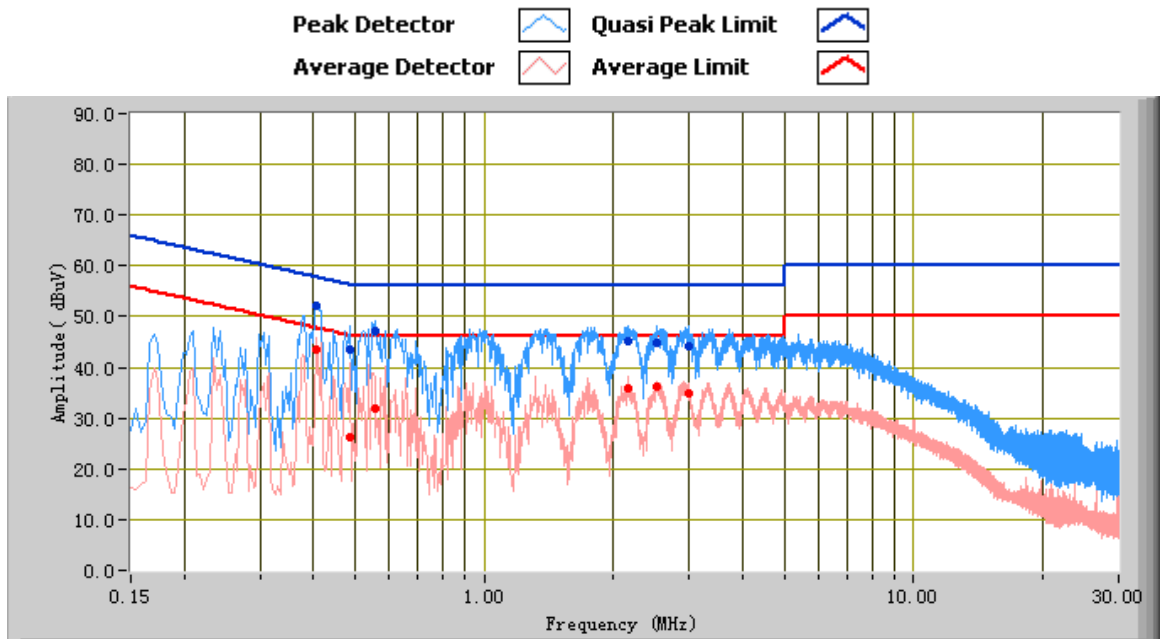

Test Data

Phase Neutral Plot at 120Vac, 60Hz

Frequency (MHz)	Quasi Peak (dBµV)	Limit (dBµV)	Margin (dB)	Average (dBµV)	Limit (dBµV)	Margin (dB)	Factors (dB)
0.41	52.16	57.73	-5.57	43.46	47.73	-4.27	11.21
0.55	47.05	56.00	-8.95	31.87	46.00	-14.13	11.02
2.16	45.17	56.00	-10.83	35.71	46.00	-10.29	10.92
2.98	44.09	56.00	-11.91	35.00	46.00	-11.00	10.93
2.52	44.70	56.00	-11.30	36.30	46.00	-9.70	10.93
0.49	43.42	56.24	-12.82	26.34	46.24	-19.90	11.08

5.8 §15.209, §15.205 & §15.247(d) - Radiated Spurious Emissions & Unwanted Emissions into Restricted Frequency Bands

1. All possible modes of operation were investigated. Only the 6 worst case emissions measured, using the correct CISPR detectors, are reported. All other emissions were relatively insignificant.
2. A "-ve" margin indicates a PASS as it refers to the margin present below the limit line at the particular frequency.
3. Radiated Emissions Measurement Uncertainty
 All test measurements carried out are traceable to national standards. The uncertainty of the measurement at a confidence level of approximately 95% (in the case where distributions are normal), with a coverage factor of 2, in the range 30MHz – 1GHz & 1GHz above (3m & 10m) is +/-6dB.
4. Environmental Conditions

Temperature	26°C
Relative Humidity	63%
Atmospheric Pressure	1012mbar
5. Test date : July 24, 2013
 Tested By : Back Huang

Requirement: §15.247(d) specifies that emissions which fall in the restricted bands, as defined in §15.205(a), must comply with the radiated emission limits specified in §15.209(a).

Procedures:

Radiated Spurious Emissions Measurement

An additional consideration when performing conducted measurements of restricted band emissions is that unwanted emissions radiating from the EUT cabinet, control circuits, power leads, or intermediate circuit elements will likely go undetected in a conducted measurement configuration. To address this concern, a radiated test shall be performed to ensure that emissions emanating from the EUT cabinet (rather than the antenna port) also comply with the applicable limits.

For these radiated spurious emission measurements the EUT transmit antenna may be replaced with a termination matching the nominal impedance of the antenna. Established procedures for performing radiated measurements shall be used (see C63.10). All detected emissions must comply with the applicable limits.

Measurement Detectors

§15.35(a) specifies that on frequencies less than and below 1000 MHz, the radiated emissions limits assume the use of a CISPR quasi-peak detector function and related measurement bandwidths. §15.35(b) specifies that on frequencies above 1000 MHz, the radiated emissions limits assume the use of an average detector and a minimum resolution bandwidth of 1 MHz. In addition, §15.35(b) that when average radiated emissions measurements are specified there is also a limit on the peak emissions level which is 20 dB above the applicable maximum permitted average emission limit. These specifications also apply to conducted emissions measurements.

1. CISPR Quasi-Peak Measurement

The specifications for the measuring instrument using the CISPR quasi-peak detector can be found in Publication 16 of the International Special Committee on Radio Frequency Interference (CISPR) of the International Electrotechnical Commission.

As an alternative to CISPR quasi-peak measurement, compliance can be demonstrated to the applicable emission limits using a peak detector.

2. Peak Power Measurement Procedure

Utilize the peak power measurement procedure specified in Section 8.1.1 with the following modifications:

Set analyzer center frequency to the frequency associated with the restricted band emission under examination.

Set RBW = 1 MHz.

Note that if the peak measured value complies with the average limit, it is not necessary to perform a separate average measurement. If this option is exercised, it should be so noted in the test report.

3. Average Power Measurement Procedures

The average restricted band emission levels must be measured with the EUT transmitting continuously ($\geq 98\%$ duty cycle) at its maximum power control level. Optionally, video triggering/signal gating can be used to ensure that measurements are performed only when the EUT is transmitting at its maximum power control level.

The average power measurement procedures described in Section 8.2 shall be used with the following modifications:

Set analyzer center frequency to the frequency associated with the restricted band emission.



Set span to at least 1 MHz.

Use peak marker function to determine the highest amplitude within the RBW (1 MHz).

Test Result: Pass

Test Mode:	Transmitting Mode(Worse Case)
-------------------	--------------------------------------

(Below 1GHz)

Peak Detector 
 Quasi Peak Limit 

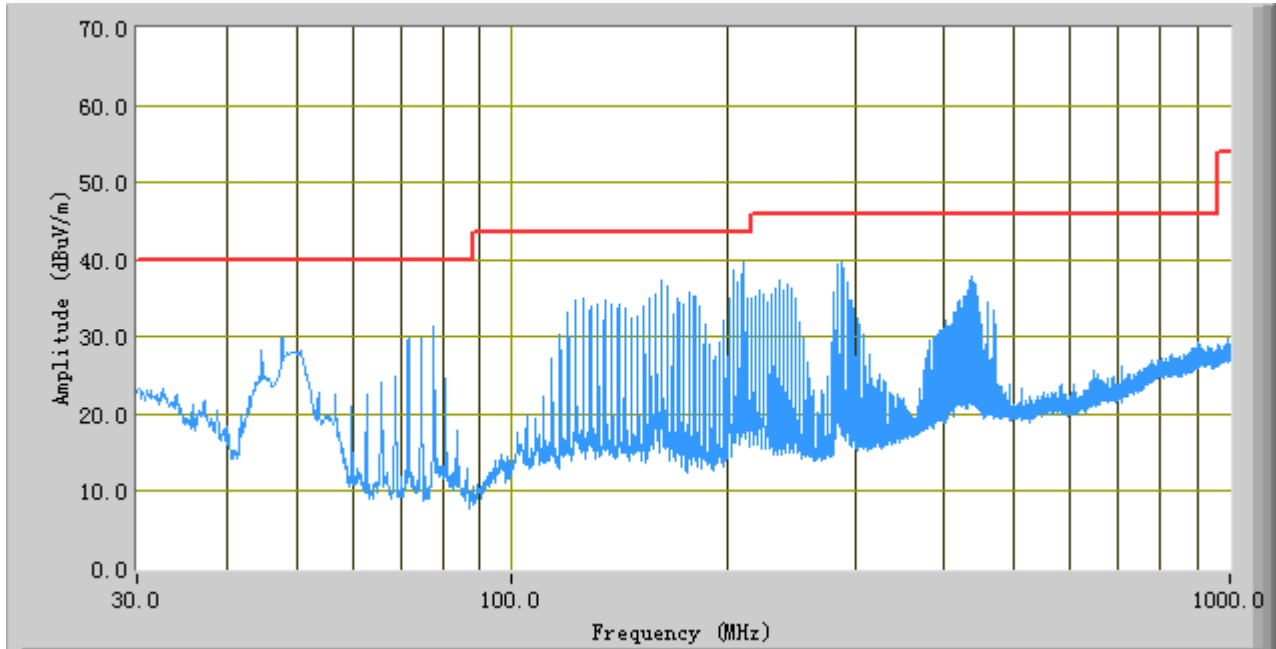

Test Data

Vertical & Horizontal Polarity Plot @3m

Frequency (MHz)	Peak (dBuV/m)	Azimuth	Polarity(H/V)	Height (cm)	Factors (dB)	Limit (dBuV)	Margin (dB)
209.45	39.78	155.00	H	100.00	-7.98	43.52	-3.74
203.51	38.69	124.00	H	100.00	-8.06	43.52	-4.83
161.44	37.24	319.00	H	300.00	-8.21	43.52	-6.28
287.05	39.55	276.00	H	100.00	-6.86	46.00	-6.45
176.35	35.71	160.00	H	100.00	-8.74	43.52	-7.81
436.43	37.75	231.00	V	100.00	-2.62	46.00	-8.25

Above 1 GHz:

Test Mode: Transmitting

Note: Other modes were verified, only the result of worst case basic rate mode was presented.

Mode: 802.11b
Low Channel (2412 MHz)

Frequency (MHz)	Substituted level (dBµV/m)	Detector (PK/AV)	Direction (degree)	Height (cm)	Polarity (H/V)	Ant. Factor (dB/m)	Cable Loss (dB)	Pre-Amp. Gain (dB)	Cord. Amp. (dBµV/m)	Limit (dBµV/m)	Margin (dB)
4824	37.57	AV	101	120	V	33.31	3.3	24	50.18	54	-3.82
4824	39.54	AV	256	110	H	33.31	3.3	24	52.15	54	-1.85
4824	43.37	PK	101	120	V	33.31	3.3	24	55.98	74	-18.02
4824	44.81	PK	256	110	H	33.31	3.3	24	57.42	74	-16.58
5436	37.68	AV	121	130	V	34.29	3.8	24	51.77	54	-2.23
5436	37.98	AV	274	120	H	34.29	3.8	24	52.07	54	-1.93
5436	44.33	PK	121	130	V	34.29	3.8	24	58.42	74	-15.58
5436	44.95	PK	274	120	H	34.29	3.8	24	59.04	74	-14.96

Middle Channel (2437 MHz)

Frequency (MHz)	Substituted level (dBµV/m)	Detector (PK/AV)	Direction (degree)	Height (cm)	Polarity (H/V)	Ant. Factor (dB/m)	Cable Loss (dB)	Pre-Amp. Gain (dB)	Cord. Amp. (dBµV/m)	Limit (dBµV/m)	Margin (dB)
4874	38.23	AV	175	110	V	33.38	3.3	24	50.91	54	-3.09
4874	40.12	AV	287	100	H	33.38	3.3	24	52.8	54	-1.2
4874	43.95	PK	175	110	V	33.38	3.3	24	56.63	74	-17.37
4874	45.53	PK	287	100	H	33.38	3.3	24	58.21	74	-15.79
5087	37.87	AV	110	110	V	33.9	3.4	24	51.17	54	-2.83
5087	37.93	AV	339	110	H	33.9	3.4	24	51.23	54	-2.77
5087	44.81	PK	110	110	V	33.9	3.4	24	58.11	74	-15.89
5087	44.78	PK	339	110	H	33.9	3.4	24	58.08	74	-15.92

High Channel (2462 MHz)

Frequency (MHz)	Substituted level (dBµV/m)	Detector (PK/AV)	Direction (degree)	Height (cm)	Polarity (H/V)	Ant. Factor (dB/m)	Cable Loss (dB)	Pre-Amp. Gain (dB)	Cord. Amp. (dBµV/m)	Limit (dBµV/m)	Margin (dB)
4924	38.46	AV	158	120	V	33.62	3.3	24	51.38	54	-2.62
4924	39.84	AV	221	110	H	33.62	3.3	24	52.76	54	-1.24
4924	44.18	PK	158	120	V	33.62	3.3	24	57.1	74	-16.9
4924	45.21	PK	221	110	H	33.62	3.3	24	58.13	74	-15.87
5386	37.99	AV	139	110	V	34.14	3.8	24	51.93	54	-2.07
5386	38.43	AV	229	100	H	34.14	3.8	24	52.37	54	-1.63
5386	44.59	PK	139	110	V	34.14	3.8	24	58.53	74	-15.47
5386	45.16	PK	229	100	H	34.14	3.8	24	59.1	74	-14.9

Annex A. TEST INSTRUMENT & METHOD

Annex A.i. TEST INSTRUMENTATION & GENERAL PROCEDURES

Instrument	Model	Serial #	Calibration Date	Calibration Due Date
AC Line Conducted Emissions				
EMI test receiver	ESL6	100262	11/19/2012	11/18/2013
Line Impedance Stabilization Network	LI-125A	191106	11/14/2012	11/13/2013
Line Impedance Stabilization Network	LI-125A	191107	11/14/2012	11/13/2013
Double Ridge Horn Antenna (1 ~18GHz)	AH-118	071259	11/20/2012	11/19/2013
Transient Limiter	LIT-153	531118	03/03/2013	03/02/2014
RF conducted test				
Agilent ESA-E SERIES SPECTRUM ANALYZER	E4407B	CFG038	10/25/2012	10/24/2013
Power Splitter	1#	1#	02/02/2013	02/01/2014
Temperature/Humidity Chamber	1007H	N/A	01/07/2013	01/06/2014
DC Power Supply	E3640A	MY4000401 3	03/22/2013	03/21/2014
Radiated Emissions				
EMI test receiver	ESL6	100262	11/19/2012	11/18/2013
Positioning Controller	UC3000	MF78020828 2	11/19/2012	11/18/2013
OPT 010 AMPLIFIER(0.1-1300MHz)	8447E	2727A02430	11/19/2012	11/18/2013
Microwave Preamplifier(0.5 ~ 18GHz)	PAM-118	443008	11/08/2012	11/07/2013
Bilog Antenna (30MHz~6GHz)	JB6	A110712	01/27/2013	01/26/2014
Double Ridge Horn Antenna (1 ~18GHz)	AH-118	071283	11/20/2012	11/19/2013

Annex A.ii. CONDUCTED EMISSIONS TEST DESCRIPTION

Test Set-up

1. The EUT and supporting equipment were set up in accordance with the requirements of the standard on top of a 1.5m x 1m x 0.8m high, non-metallic table, as shown in Annex B.
2. The power supply for the EUT was fed through a 50Ω/50μH EUT LISN, connected to filtered mains.
3. The RF OUT of the EUT LISN was connected to the EMI test receiver via a low-loss coaxial cable.
4. All other supporting equipments were powered separately from another main supply.

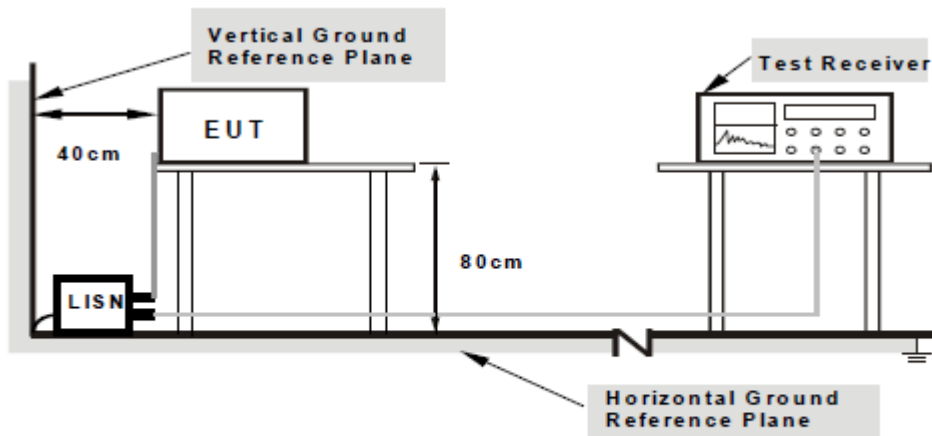

**Note: 1. Support units were connected to second LISN.
 2. Both of LISNs (AMN) are 80cm from EUT and at least 80cm from other units and other metal planes support units.**

For the actual test configuration, please refer to the related item – Photographs of the Test Configuration 1.

Test Method

1. The EUT was switched on and allowed to warm up to its normal operating condition.
2. A scan was made on the NEUTRAL line (for AC mains) or Earth line (for DC power) over the required frequency range using an EMI test receiver.
3. High peaks, relative to the limit line, were then selected.
4. The EMI test receiver was then tuned to the selected frequencies and the necessary measurements made with a receiver bandwidth setting of 10 kHz. For FCC tests, only Quasi-peak measurements were made; while for CISPR/EN tests, both Quasi-peak and Average measurements were made.
5. Steps 2 to 4 were then repeated for the LIVE line (for AC mains) or DC line (for DC power).

Description of Conducted Emission Program

This EMC Measurement software run LabView automation software and offers a common user interface for electromagnetic interference (EMI) measurements. This software is a modern and powerful tool for controlling and monitoring EMI test receivers and EMC test systems. It guarantees reliable collection, evaluation, and documentation of measurement results. Basically, this program will run a pre-scan measurement before it proceeds with the final measurement. The pre-scan routine will run the common scan range from 150 kHz to 30 MHz; the program will first start a peak and average scan on selectable measurement time and step size. After the program complete the pre-scan, this program will perform the Quasi Peak and Average measurement, based on the pre-scan peak data reduction result.

Sample Calculation Example

At 20 MHz limit = 250 μ V = 47.96 dB μ V

Transducer factor of LISN, pulse limiter & cable loss at 20 MHz = 11.20 dB

Q-P reading obtained directly from EMI Receiver = 40.00 dB μ V
(Calibrated for system losses)

Therefore, Q-P margin = 47.96 – 40.00 = 7.96 i.e. **7.96 dB below limit**

Annex A. iii RADIATED EMISSIONS TEST DESCRIPTION

EUT Characterisation

EUT characterisation, over the frequency range from 30MHz to 10th Harmonic , was done in order to minimise radiated emissions testing time while still maintaining high confidence in the test results.

The EUT was placed in the chamber, at a height of about 0.8m on a turntable. Its radiated emissions frequency profile was observed, using a spectrum analyzer /receiver with the appropriate broadband antenna placed 3m away from the EUT. Radiated emissions from the EUT were maximised by rotating the turntable manually, changing the antenna polarisation and manipulating the EUT cables while observing the frequency profile on the spectrum analyzer / receiver. Frequency points at which maximum emissions occurred, clock frequencies and operating frequencies were then noted for the formal radiated emissions test at the Open Area Test Site (OATS).

Test Set-up

1. The EUT and supporting equipment were set up in accordance with the requirements of the standard on top of a 1.5m X 1.0m X 0.8m high, non-metallic table.
2. The filtered power supply for the EUT and supporting equipment were tapped from the appropriate power sockets located on the turntable.
3. The relevant broadband antenna was set at the required test distance away from the EUT and supporting equipment boundary.

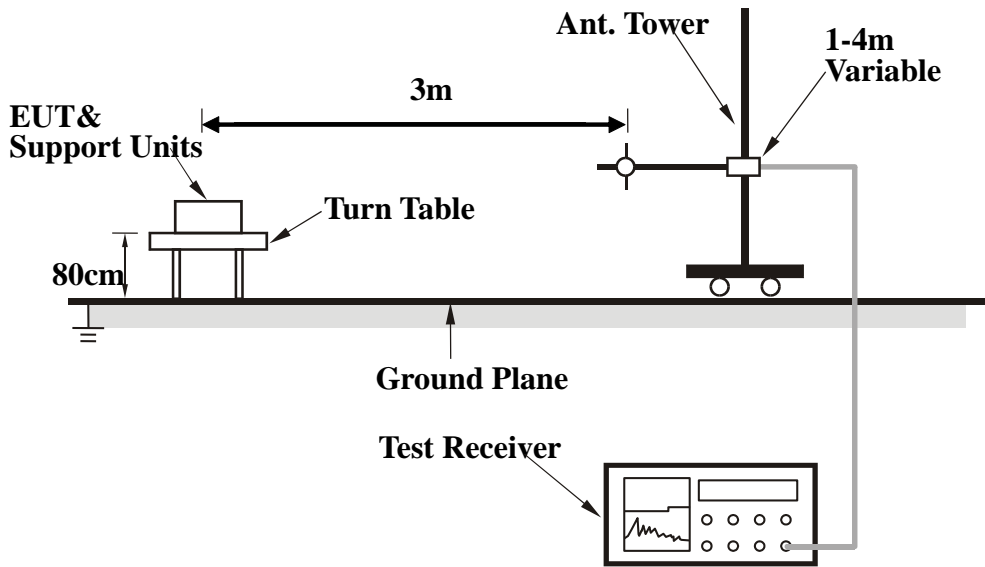

Test Method

The following procedure was performed to determine the maximum emission axis of EUT:

1. With the receiving antenna is H polarization, rotate the EUT in turns with three orthogonal axes to determine the axis of maximum emission.
2. With the receiving antenna is V polarization, rotate the EUT in turns with three orthogonal axes to determine the axis of maximum emission.
3. Compare the results derived from above two steps. So, the axis of maximum emission from EUT was determined and the configuration was used to perform the final measurement.

Final Radiated Emission Measurement

1. Setup the configuration according to figure 1. Turn on EUT and make sure that it is in normal function.
2. For emission frequencies measured below 1 GHz, a pre-scan is performed in a shielded chamber to determine the accurate frequencies of higher emissions will be checked on a open test site. As the same purpose, for emission frequencies measured above 1 GHz, a pre-scan also be performed with a 1 meter measuring distance before final test.
3. For emission frequencies measured below and above 1 GHz, set the spectrum analyzer on a 100 kHz and 1 MHz resolution bandwidth respectively for each frequency measured in step 2.
4. The search antenna is to be raised and lowered over a range from 1 to 4 meters in horizontally polarized orientation. Position the highness when the highest value is indicated on spectrum analyzer, then change the orientation of EUT on test table over a range from 0 ° to 360 ° with a speed as slow as possible, and keep the azimuth that highest emission is indicated on the spectrum analyzer. Vary the antenna position again and record the highest value as a final reading.
5. Repeat step 4 until all frequencies need to be measured was complete.
6. Repeat step 5 with search antenna in vertical polarized orientations.

During the radiated emission test, the Spectrum Analyzer was set with the following configurations:

Frequency Band (MHz)	Function	Resolution bandwidth	Video Bandwidth
30 to 1000	Peak	100 kHz	100 kHz
Above 1000	Peak	1 MHz	1 MHz
	Average	1 MHz	10 Hz

Sample Calculation Example

The field strength is calculated by adding the Antenna Factor and Cable Factor, and subtracting the Amplifier Gain (if any) from the measured reading. For the limit is employed average value, therefore the peak value can be transferred to average value by subtracting the duty factor. The basic equation with a sample calculation is as follows:

$$\text{Peak} = \text{Reading} + \text{Corrected Factor}$$

where

$$\text{Corr. Factor} = \text{Antenna Factor} + \text{Cable Factor} - \text{Amplifier Gain (if any)}$$

And the average value is

$$\text{Average} = \text{Peak Value} + \text{Duty Factor or}$$

$$\text{Set RBW} = 1\text{MHz, VBW} = 10\text{Hz.}$$

Note :

If the measured frequencies are fall in the restricted frequency band, the limit employed must be quasi peak value when frequencies are below or equal to 1 GHz. And the measuring instrument is set to quasi peak detector function.

Annex B. EUT AND TEST SETUP PHOTOGRAPHS

Annex B.i. Photograph 1: EUT External Photo



Whole Package - Top View



SIEMIC, INC.

Accessing global markets

Title: RF Test Report for Mobile Phone
Main Model: S470
Serial Model: N/A
To: FCC Part 15.247: 2012, ANSI C63.4: 2009

Report No.: 13070170-FCC-R4
Issue Date: July 26, 2013
Page: 58 of 73
www.siemic.com.cn



EUT - Front View



EUT - Rear View



SIEMIC, INC.

Accessing global markets

Title: RF Test Report for Mobile Phone
Main Model: S470
Serial Model: N/A
To: FCC Part 15.247: 2012, ANSI C63.4: 2009

Report No.: 13070170-FCC-R4
Issue Date: July 26, 2013
Page: 59 of 73
www.siemic.com.cn



EUT - Top View



EUT - Bottom View



SIEMIC, INC.

Accessing global markets

Title: RF Test Report for Mobile Phone
Main Model: S470
Serial Model: N/A
To: FCC Part 15.247: 2012, ANSI C63.4: 2009

Report No.: 13070170-FCC-R4
Issue Date: July 26, 2013
Page: 60 of 73
www.siemic.com.cn



EUT - Left View



EUT - Right View

Annex B.ii. Photograph 2: EUT Internal Photo



Cover Off - Top View



Cover Off - Rear Housing View



Adapter View



Battery View



Rear Housing - Uncover View

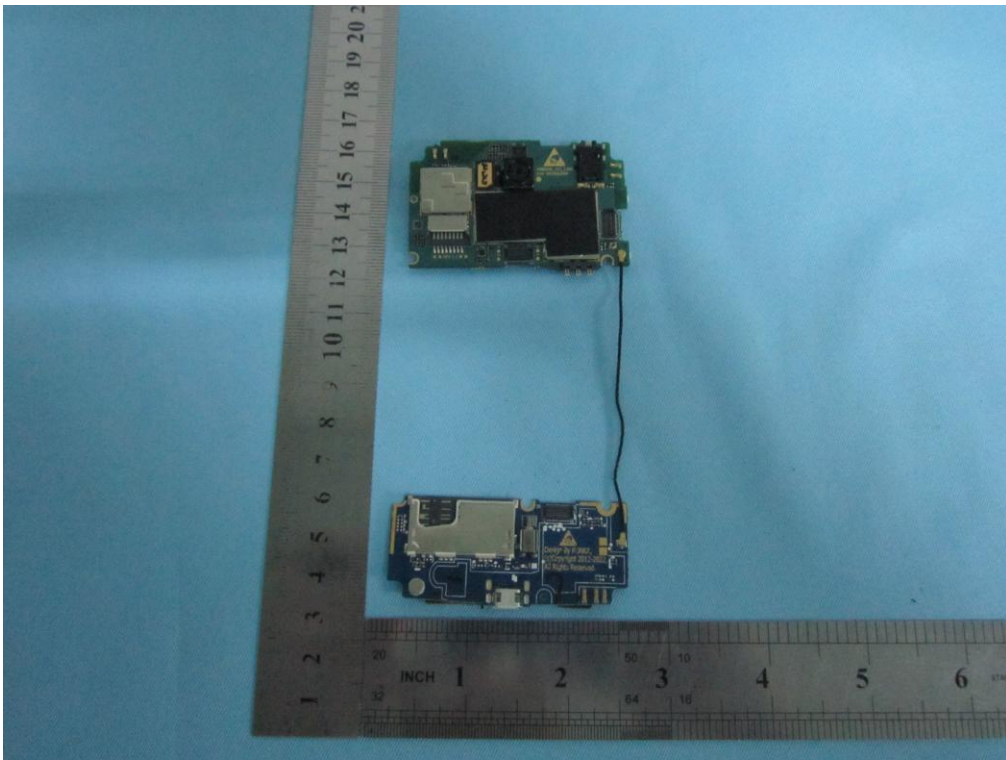

Mainboard - Bottom View

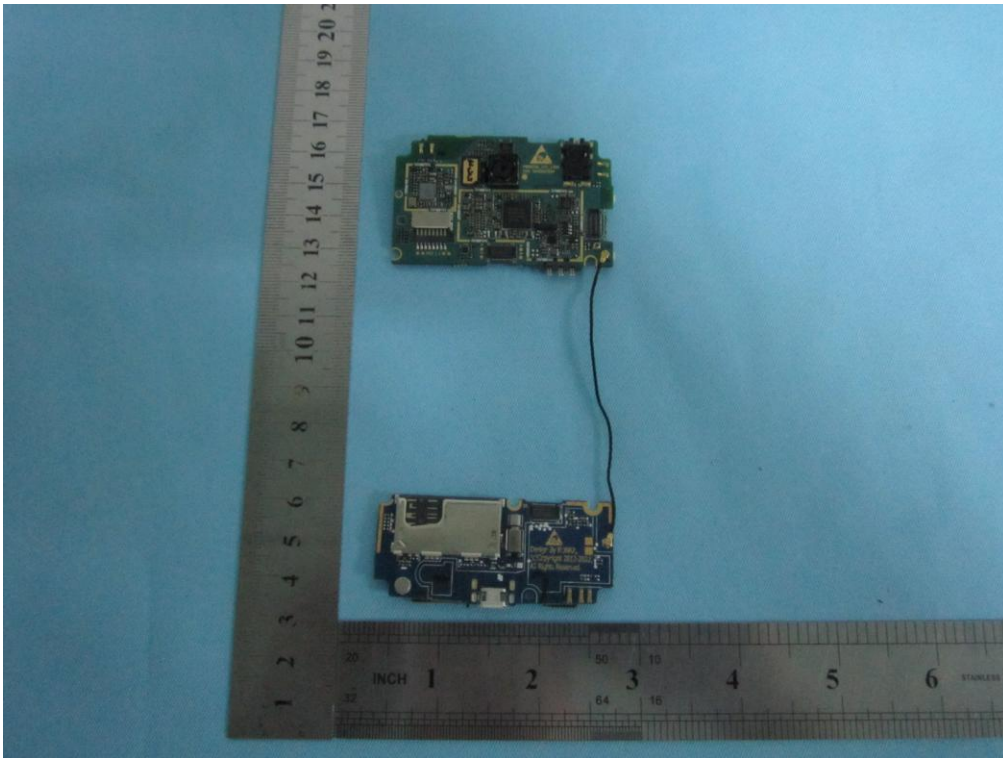

Mainboard Without Shielding - Bottom View

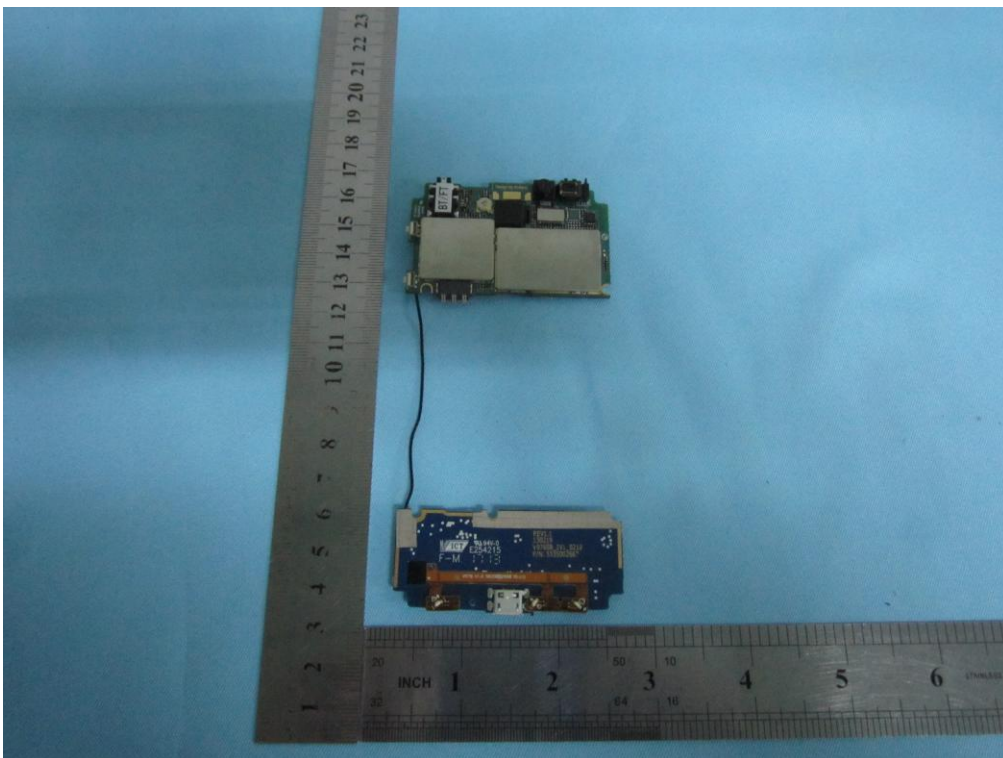

Mainboard - Top View

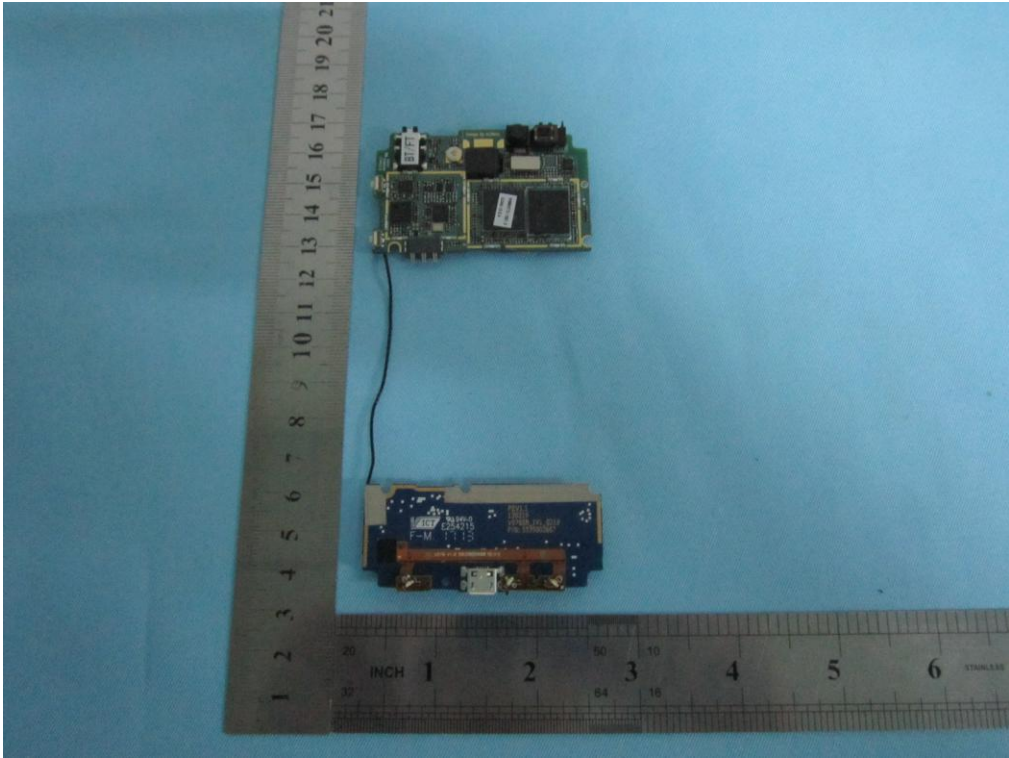

Mainboard Without Shielding - Top View

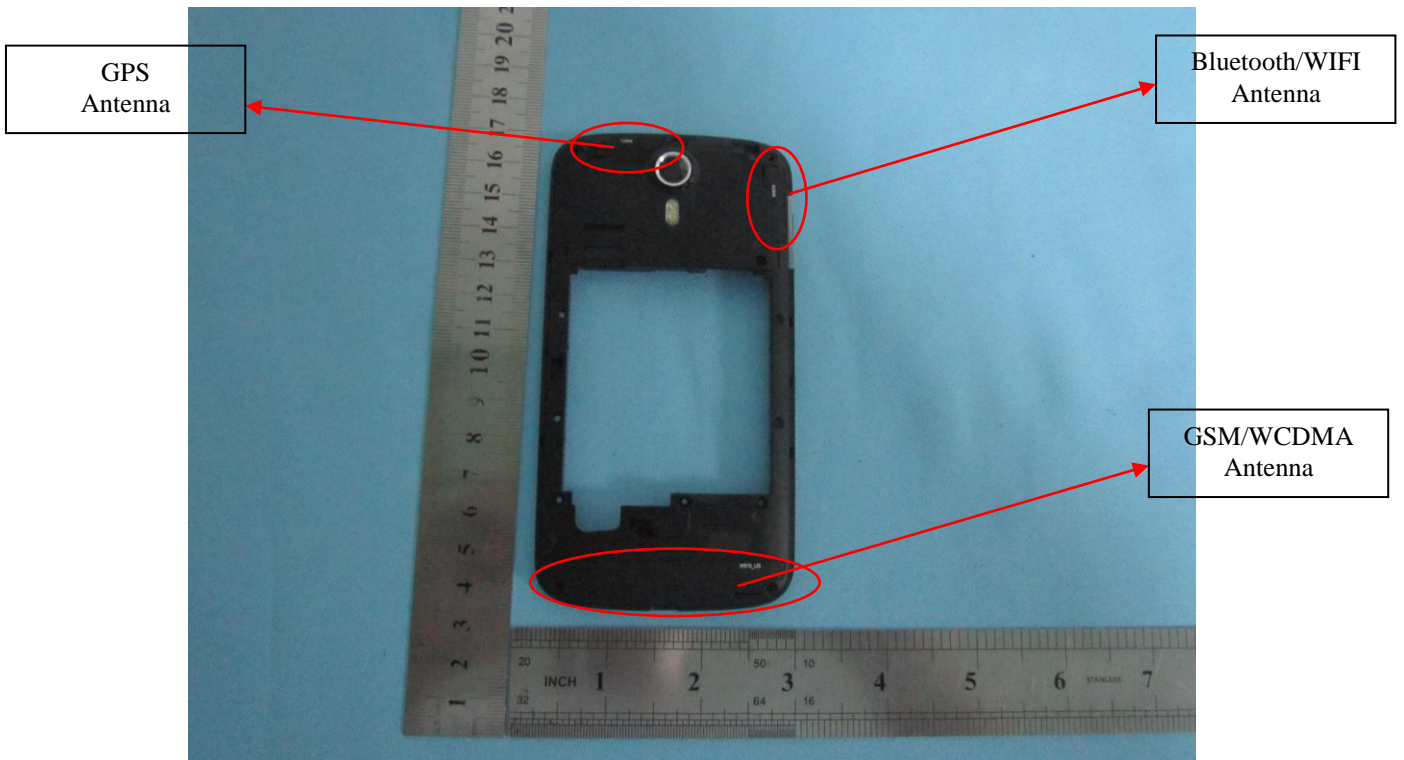

Antenna View

Annex B.iii. Photograph 3: Test Setup Photo



Conducted Emissions Test Setup Front View



Conducted Emissions Test Setup Side View

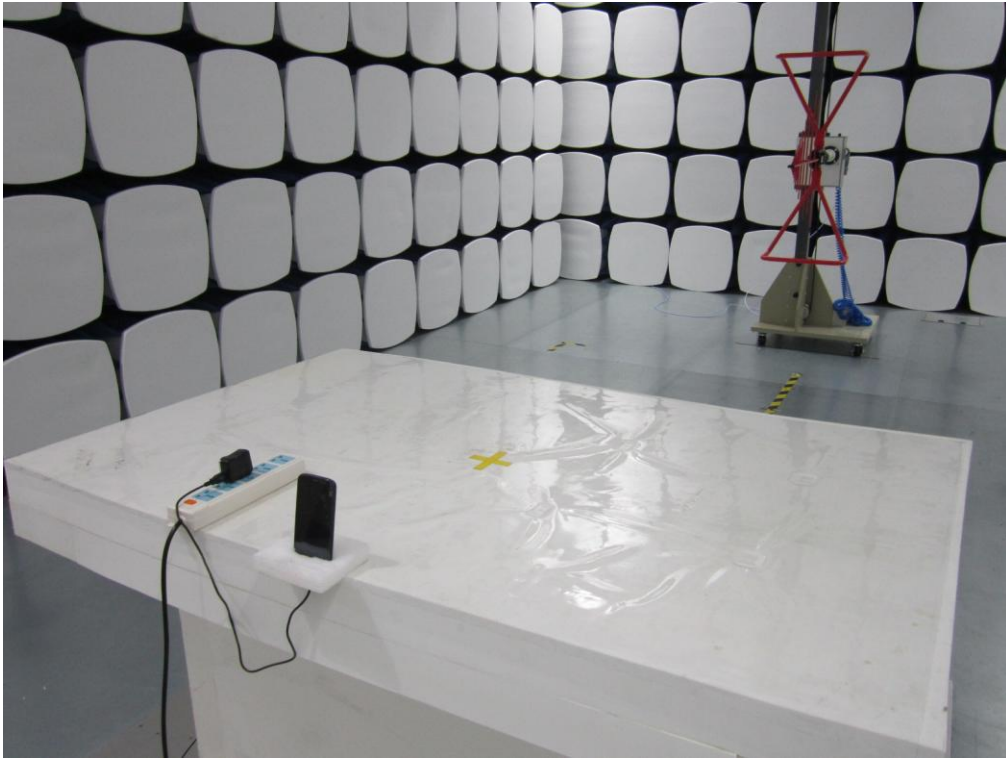

Radiated Spurious Emissions Test Setup Below 1GHz - Front View

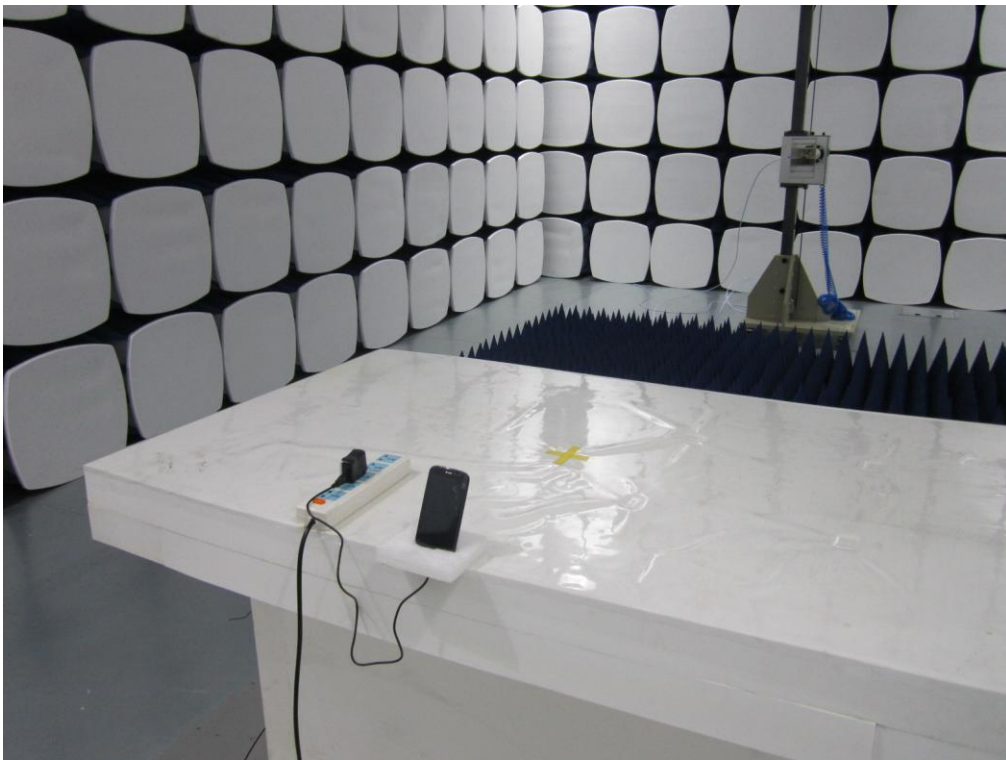

Radiated Spurious Emissions Test Setup Above 1GHz -Front View

Annex C. TEST SETUP AND SUPPORTING EQUIPMENT

EUT TEST CONDITIONS

Annex C. i. SUPPORTING EQUIPMENT DESCRIPTION

The following is a description of supporting equipment and details of cables used with the EUT.

Manufacturer	Equipment Description (Including Brand Name)	Model	Calibration Date	Calibration Due Date
N/A	N/A	N/A	N/A	N/A

Block Configuration Diagram for AC Line Conducted Emissions

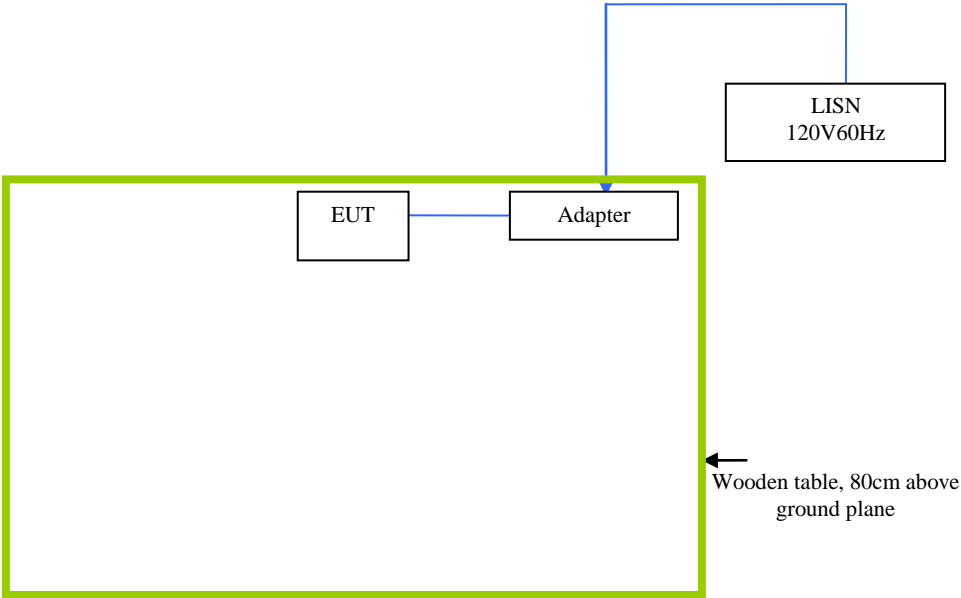

Block Configuration Diagram for Radiated Emissions

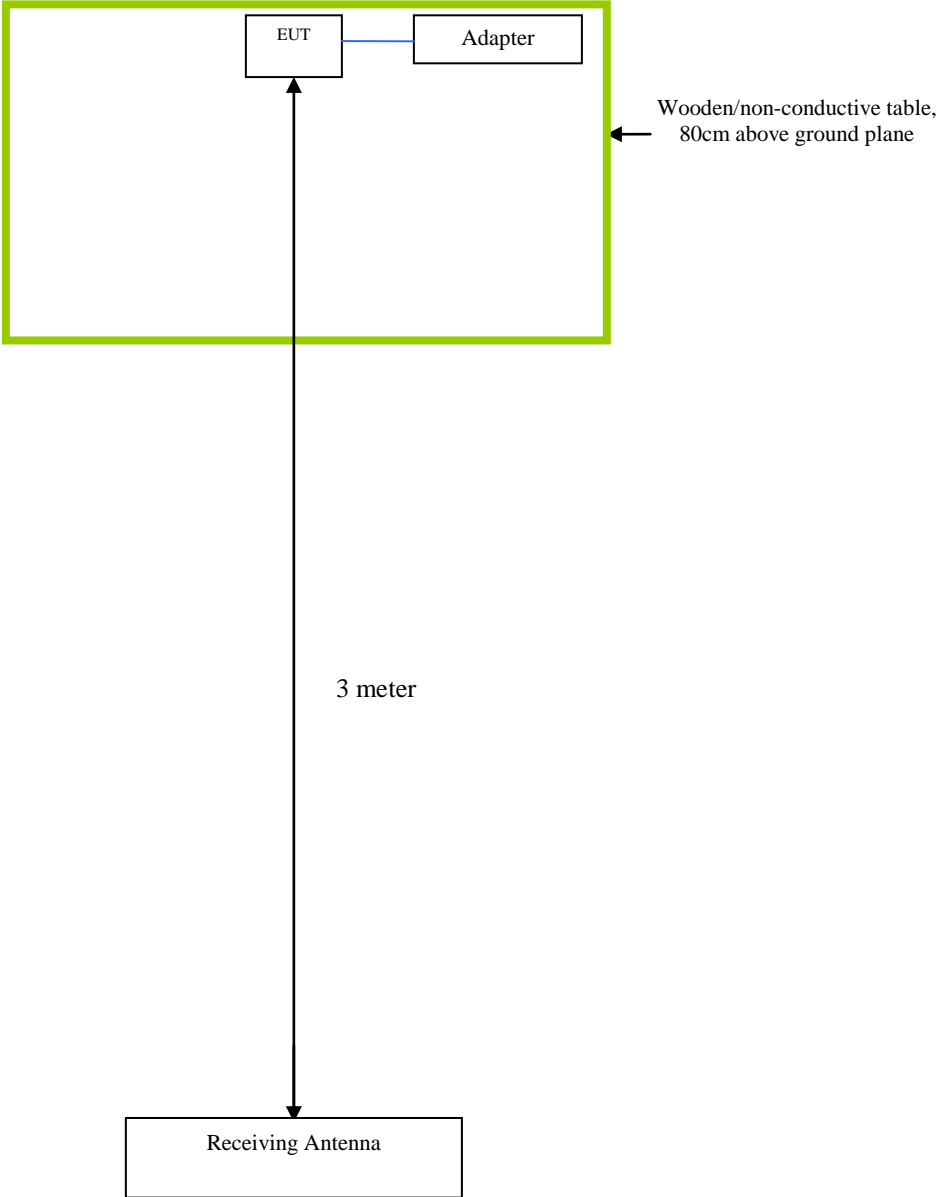

Annex C.ii. EUT OPERATING CONDITIONS

The following is the description of how the EUT is exercised during testing.

Test	Description Of Operation
Emissions Testing	The EUT was continuously transmitting to stimulate the worst case.



SIEMIC, INC.

Accessing global markets

Title: RF Test Report for Mobile Phone
Main Model: S470
Serial Model: N/A
To: FCC Part 15.247: 2012, ANSI C63.4: 2009

Report No.: 13070170-FCC-R4
Issue Date: July 26, 2013
Page: 72 of 73
www.siemic.com.cn

Annex D. USER MANUAL / BLOCK DIAGRAM / SCHEMATICS / PART LIST

Please see attachment



SIEMIC, INC.

Accessing global markets

Title: RF Test Report for Mobile Phone
Main Model: S470
Serial Model: N/A
To: FCC Part 15.247: 2012, ANSI C63.4: 2009

Report No.: 13070170-FCC-R4
Issue Date: July 26, 2013
Page: 73 of 73
www.siemic.com.cn

Annex E. DECLARATION OF SIMILARITY

NONE