

# Verykool USA INC.

## Mobile Phone

**Main Model: s352**

**Serial Model: N/A**

**February 25, 2014**



**Report No.: 14070005-FCC-R4**

**(This report supersedes none)**

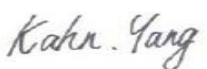
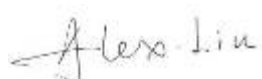

**Modifications made to the product : None**

**This Test Report is Issued Under the Authority of:**

		
<b>Kahn Yang</b> Compliance Engineer	<b>Alex Liu</b> Technical Manager	

**This test report may be reproduced in full only.  
Test result presented in this test report is applicable to the representative sample only.**

# RF Test Report

**SIEMIC, INC.**  
Assessing global markets



## Laboratory Introduction

SIEMIC, headquartered in the heart of Silicon Valley, with superior facilities in US and Asia, is one of the leading independent testing and certification facilities providing customers with one-stop shop services for Compliance Testing and Global Certifications.



In addition to [testing](#) and [certification](#), SIEMIC provides initial design reviews and [compliance management](#) through out a project. Our extensive experience with [China](#), [Asia Pacific](#), [North America](#), [European](#), and [international](#) compliance requirements, assures the fastest, most cost effective way to attain regulatory compliance for the [global markets](#).

### SIEMIC (Shenzhen - China) Laboratories Accreditations for Conformity Assessment

Country/Region	Scope
USA	EMC , RF/Wireless , Telecom
Canada	EMC, RF/Wireless , Telecom
Taiwan	EMC, RF, Telecom , Safety
Hong Kong	RF/Wireless ,Telecom
Australia	EMC, RF, Telecom , Safety
Korea	EMI, EMS, RF , Telecom, Safety
Japan	EMI, RF/Wireless, Telecom
Singapore	EMC , RF , Telecom
Europe	EMC, RF, Telecom , Safety



**SIEMIC, INC.**

Accessing global markets

Title: RF Test Report for Mobile Phone  
Main Model: s352  
Serial Model: N/A  
To: FCC Part 15.247: 2013, ANSI C63.4: 2009

Report No.: 14070005-FCC-R4  
Issue Date: February 25, 2014  
Page: 3 of 74  
[www.siemic.com](http://www.siemic.com)

---

This page has been left blank intentionally.

# CONTENTS

<b>1</b>	<b>EXECUTIVE SUMMARY &amp; EUT INFORMATION .....</b>	<b>5</b>
<b>2</b>	<b>TECHNICAL DETAILS .....</b>	<b>6</b>
<b>3</b>	<b>MODIFICATION.....</b>	<b>7</b>
<b>4</b>	<b>TEST SUMMARY.....</b>	<b>8</b>
<b>5</b>	<b>MEASUREMENTS, EXAMINATION AND DERIVED RESULTS .....</b>	<b>9</b>
	<b>ANNEX A. TEST INSTRUMENT &amp; METHOD .....</b>	<b>52</b>
	<b>ANNEX B. EUT AND TEST SETUP PHOTOGRAPHS .....</b>	<b>57</b>
	<b>ANNEX C. TEST SETUP AND SUPPORTING EQUIPMENT.....</b>	<b>69</b>
	<b>ANNEX D. USER MANUAL / BLOCK DIAGRAM / SCHEMATICS / PART LIST .....</b>	<b>73</b>
	<b>ANNEX E. DECLARATION OF SIMILARITY .....</b>	<b>74</b>

# 1 EXECUTIVE SUMMARY & EUT INFORMATION

**The purpose of this test programme was to demonstrate compliance of the Verykool USA INC., Mobile Phone and model: s352 against the current Stipulated Standards. The Mobile Phone has demonstrated compliance with the FCC Part 15.247: 2013, ANSI C63.4: 2009.**

## EUT Information

<b>EUT Description</b>	: <b>Mobile Phone</b>
<b>Main Model</b>	: <b>s352</b>
<b>Serial Model</b>	: <b>N/A</b>
<b>Antenna Gain</b>	: <b>GSM850: -0.89 dBi PCS1900: 1.28 dBi Bluetooth/BLE: 0.0015 dBi WIFI: 0.0015 dBi</b>
<b>Input Power</b>	: <b>Battery: Model: W97135A4/A5 Spec: 3.7V 1300mAh 4.81Wh Limited charger voltage: 4.2V Adapter: Model: UT-AB-D3A1+102Y Input: AC 100-264V 50/60Hz 0.2A Output: DC 5V 500mA</b>
<b>Classification Per Stipulated Test Standard</b>	: <b>FCC Part 15.247: 2013, ANSI C63.4: 2009</b>

## 2 TECHNICAL DETAILS

<b>Purpose</b>	<b>Compliance testing of Mobile Phone with stipulated standard</b>
<b>Applicant / Client</b>	<b>Verykool USA INC. 3636 Nobel Drive, Suite 325, San Diego, CA 92122</b>
<b>Manufacturer</b>	<b>Wingtech Group 6F G Area Beijing road east 668,high-tach king world, Wingtech Group, Shanghai, China 200001</b>
<b>Laboratory performing the tests</b>	<b>SIEMIC Shenzhen (Shenzhen - China) Laboratories Zone A, Floor 1, Building 2, Wan Ye Long Technology Park, South Side of Zhoushi Road, Bao'an District, Shenzhen, Guangdong, China Tel: +86-0755-2601 4629 / 2601 4953 Fax: +86-0755-2601 4953-810 Email:China@siemic.com</b>
<b>Test report reference number</b>	<b>14070005-FCC-R4</b>
<b>Date EUT received</b>	<b>February 14, 2014</b>
<b>Standard applied</b>	<b>FCC Part 15.247: 2013, ANSI C63.4: 2009</b>
<b>Dates of test (from – to)</b>	<b>February 14 to February 24, 2014</b>
<b>No of Units :</b>	<b>#1</b>
<b>Equipment Category :</b>	<b>Spread Spectrum System/Device</b>
<b>Trade Name :</b>	<b>Verykool</b>
<b>RF Operating Frequency (ies)</b>	<b>GSM850 TX : 824.2 ~ 848.8 MHz; RX : 869.2 ~ 893.8 MHz PCS1900 TX : 1850.2 ~ 1909.8 MHz; RX : 1930.2 ~ 1989.8 MHz 802.11b/g/n: 2412-2462 MHz Bluetooth &amp; BLE: 2402-2480 MHz</b>
<b>Number of Channels</b>	<b>299CH (PCS1900) and 124CH (GSM850) Bluetooth: 79CH 802.11b/g/n(20M): 11CH BLE: 40CH</b>
<b>Modulation</b>	<b>GSM / GPRS: GMSK 802.11b/g/n: DSSS/OFDM Bluetooth: GFSK&amp; <math>\pi</math>/4DQPSK&amp;8DPSK BLE: GFSK</b>
<b>GPRS Multi-slot class</b>	<b>8/10/12</b>
<b>FCC ID</b>	<b>WA6S352</b>



**SIEMIC, INC.**

Accessing global markets

Title: RF Test Report for Mobile Phone  
Main Model: s352  
Serial Model: N/A  
To: FCC Part 15.247: 2013, ANSI C63.4: 2009

Report No.: 14070005-FCC-R4  
Issue Date: February 25, 2014  
Page: 7 of 74  
[www.siemic.com](http://www.siemic.com)

### **3 MODIFICATION**

**NONE**

## 4 TEST SUMMARY

The product was tested in accordance with the following specifications.  
 All testing has been performed according to below product classification:

### Test Results Summary

FCC Rules	Description of Test	Result
§15.247 (i), §2.1093	RF Exposure	Compliance
§15.203	Antenna Requirement	Compliance
§15.247 (a)(2)	DTS (6 dB&26 dB) CHANNEL BANDWIDTH	Compliance
§15.247(b)(3)	Conducted Maximum Output Power	Compliance
§15.247(e)	Power Spectral Density	Compliance
§15.247(d)	Band-Edge & Unwanted Emissions into Non-Restricted Frequency Bands	Compliance
§15.207 (a),	AC Power Line Conducted Emissions	Compliance
§15.205, §15.209, §15.247(d)	Radiated Spurious Emissions & Unwanted Emissions into Restricted Frequency Bands	Compliance

The product, Mobile Phone, Model: s353 and s352. These two models are electrically and mechanically identical, share the same PCB Layout and components. And the difference between them is s352 has no 3G frequencies (removed related hardware of WCDMA, kept other parts the same.). Details were explained in the Declaration letter from customer.

This difference only affects the data of Conducted Emissions and Spurious Emissions, and the other test data please refer to report 13070501-FCC-R4.



# 5 MEASUREMENTS, EXAMINATION AND DERIVED RESULTS

## 5.1 §15.247 (i) and §2.1093 – RF Exposure

**Standard Requirement:**

According to §15.247 (i) and §1.1307(b)(1), systems operating under the provisions of this section shall be operated in a manner that ensures that the public is not exposed to radio frequency energy level in excess of the Commission’s guidelines.

The 1-g and 10-g SAR test exclusion thresholds for 100 MHz to 6 GHz at *test separation distances* ≤ 50 mm are determined by:

$$[(\text{max. power of channel, including tune-up tolerance, mW}) / (\text{min. test separation distance, mm})] \cdot [\sqrt{f_{\text{GHz}}}] \leq 3.0 \text{ for 1-g SAR and } \leq 7.5 \text{ for 10-g extremity SAR,}^{16} \text{ where}$$

- $f_{\text{GHz}}$  is the RF channel transmit frequency in GHz
- Power and distance are rounded to the nearest mW and mm before calculation<sup>17</sup>
- The result is rounded to one decimal place for comparison

The test exclusions are applicable only when the minimum *test separation distance* is ≤ 50 mm and for transmission frequencies between 100 MHz and 6 GHz. When the minimum *test separation distance* is < 5 mm, a distance of 5 mm is applied to determine SAR test exclusion.

Approximate SAR Test Exclusion Power Thresholds at Selected Frequencies and Test Separation Distances are illustrated in the following Table.

MHz	5	10	15	20	25	mm
150	39	77	116	155	194	SAR Test Exclusion Threshold (mW)
300	27	55	82	110	137	
450	22	45	67	89	112	
835	16	33	49	66	82	
900	16	32	47	63	79	
1500	12	24	37	49	61	
1900	11	22	33	44	54	
2450	10	19	29	38	48	
3600	8	16	24	32	40	
5200	7	13	20	26	33	
5400	6	13	19	26	32	
5800	6	12	19	25	31	

Routine SAR evaluation refers to that specifically required by § 2.1093, using measurements or computer simulation. When routine SAR evaluation is not required, portable transmitters with output power greater than the applicable low threshold require SAR evaluation to qualify for TCB approval.

Note: The following test data please refer to report 13070501-FCC-R4.

Two antennas are available for the EUT (GSM antenna, Bluetooth/WIFI/BLE antenna). the maximum average output power(turn-up power) of WIFI is 9.15 dBm = 8.22 mW < 9.6 mW

According to KDB 447498, no stand-alone required for WIFI antenna, and no simultaneous SAR measurement is required , please refer to SAR report.

**Test Result: Pass**

## **5.2 §15.203 - ANTENNA REQUIREMENT**

### **Applicable Standard**

According to § 15.203, an intentional radiator shall be designed to ensure that no antenna other than that furnished by the responsible party shall be used with the device. The use of a permanently attached antenna or of an antenna that uses a unique coupling to the intentional radiator shall be considered sufficient to comply with the provisions of this section. The manufacturer may design the unit so that a broken antenna can be replaced by the user, but the user of a standard antenna jack or electrical connector is prohibited. The structure and application of the EUT were analyzed to determine compliance with section §15.203 of the rules. §15.203 state that the subject device must meet the following criteria:

- a. Antenna must be permanently attached to the unit.
- b. Antenna must use a unique type of connector to attach to the EUT.

Unit must be professionally installed, and installer shall be responsible for verifying that the correct antenna is employed with the unit.

And according to FCC 47 CFR section 15.247 (b), if the transmitting antennas of directional gain greater than 6dBi are used, the power shall be reduced by the amount in dB that the directional gain of the antenna exceeds 6 dBi.

### **Antenna Connector Construction**

The EUT has 2 antennas: a comments antenna for Bluetooth/WIFI/BLE, the gain is 0.0015 dBi;  
a PIFA antenna for GSM, the gain are -0.89 dBi for GSM, 1.28 dBi for PCS;  
which in accordance to section 15.203, please refer to the internal photos.

**Test Result: Pass**

### **5.3 §15.247(a) (2) –DTS (6 dB&26 dB) CHANNEL BANDWIDTH**

1. Conducted Measurement  
 EUT was set for low, mid, high channel with modulated mode and highest RF output power.  
 The spectrum analyzer was connected to the antenna terminal.
2. Environmental Conditions
 

Temperature	25°C
Relative Humidity	50%
Atmospheric Pressure	1019mbar
3. Conducted Emissions Measurement Uncertainty  
 All test measurements carried out are traceable to national standards. The uncertainty of the measurement at a confidence level of approximately 95% (in the case where distributions are normal), with a coverage factor of 2, in the range 30MHz – 40GHz is ±1.5dB.
4. Test date : November 05, 2013  
 Tested By : Kahn Yang

**Requirement(s):** The minimum 6 dB bandwidth of a DTS transmission shall be at least 500 kHz. Within this document, this bandwidth is referred to as the DTS bandwidth. The procedures provided herein for measuring the maximum peak conducted output power assume the use of the DTS bandwidth.

**Procedures:**

1. Set RBW = 100 kHz.
2. Set the video bandwidth (VBW)  $\geq 3 \times$  RBW.
3. Detector = Peak.
4. Trace mode = max hold.
5. Sweep = auto couple.
6. Allow the trace to stabilize.
7. Measure the maximum width of the emission that is constrained by the frequencies associated with the two outermost amplitude points (upper and lower) that are attenuated by 6 dB relative to the maximum level measured in the fundamental emission.

**Test Result: Pass.**

Note: The following test data please refer to report 13070501-FCC-R4.

Please refer to the following tables and plots.

**6dB bandwidth:**

Channel	Channel Frequency (MHz)	Data Rate (Mbps)	Measured 6dB Bandwidth (MHz)	FCC Part 15.247 Limit (kHz)
<b>802.11b mode</b>				
Low	2412	1	10.108	> 500
Middle	2437	1	10.097	> 500
High	2462	1	10.096	> 500
<b>802.11g mode</b>				
Low	2412	6	16.484	> 500
Middle	2437	6	16.465	> 500
High	2462	6	16.449	> 500
<b>802.11n(20M) mode</b>				
Low	2412	MCS0	17.628	> 500
Middle	2437	MCS0	17.650	> 500
High	2462	MCS0	17.654	> 500

**802.11b Low Channel**

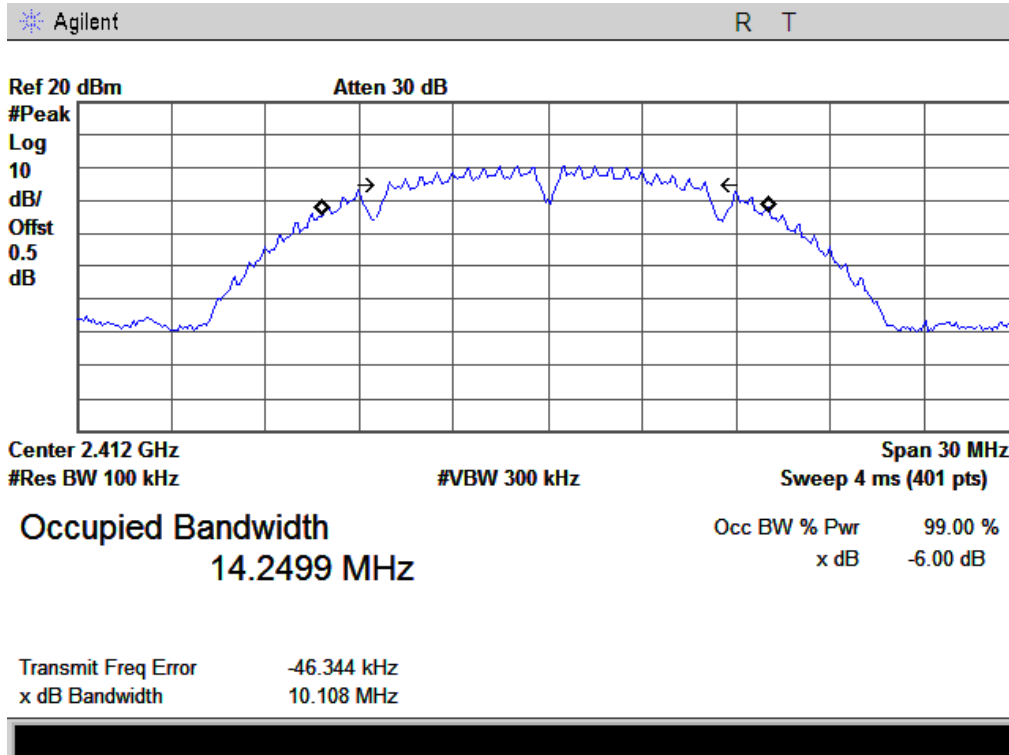



# SIEMIC, INC.

Accessing global markets

Title: RF Test Report for Mobile Phone  
Main Model: s352  
Serial Model: N/A  
To: FCC Part 15.247: 2013, ANSI C63.4: 2009

Report No.: 14070005-FCC-R4  
Issue Date: February 25, 2014  
Page: 13 of 74  
www.siemic.com

## 802.11b Middle Channel

Agilent R T

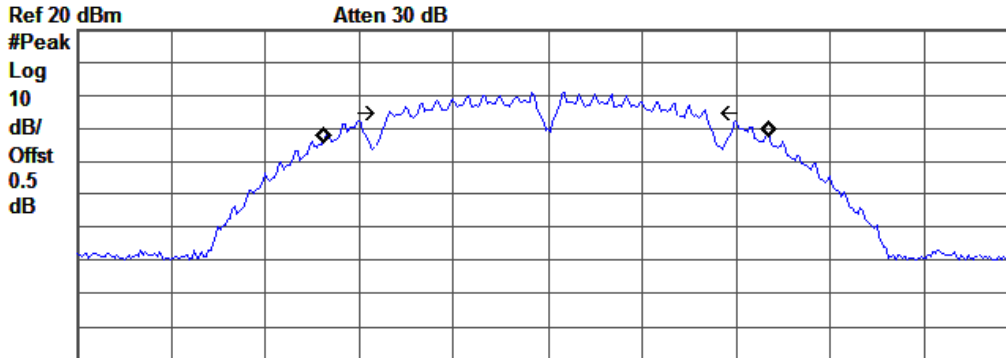

Center 2.437 GHz Span 30 MHz  
#Res BW 100 kHz #VBW 300 kHz #Sweep 4 ms (401 pts)

**Occupied Bandwidth**  
14.2231 MHz

Occ BW % Pwr 99.00 %  
x dB -6.00 dB

Transmit Freq Error -45.212 kHz  
x dB Bandwidth 10.097 MHz

## 802.11b High Channel

Agilent R T

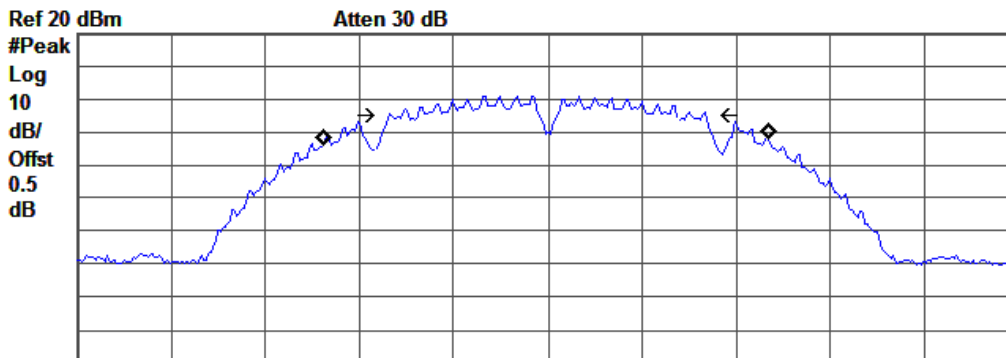

Center 2.462 GHz Span 30 MHz  
#Res BW 100 kHz #VBW 300 kHz #Sweep 4 ms (401 pts)

**Occupied Bandwidth**  
14.2149 MHz

Occ BW % Pwr 99.00 %  
x dB -6.00 dB

Transmit Freq Error -51.603 kHz  
x dB Bandwidth 10.096 MHz



# SIEMIC, INC.

Accessing global markets

Title: RF Test Report for Mobile Phone  
Main Model: s352  
Serial Model: N/A  
To: FCC Part 15.247: 2013, ANSI C63.4: 2009

Report No.: 14070005-FCC-R4  
Issue Date: February 25, 2014  
Page: 14 of 74  
www.siemic.com

## 802.11g Low Channel

Agilent R T

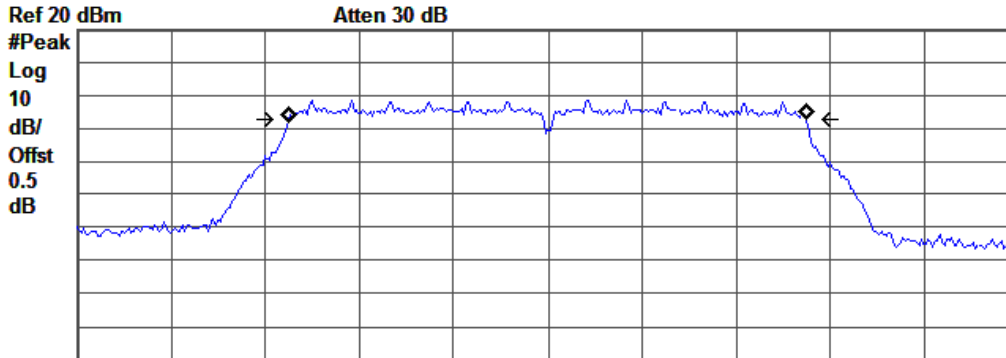

Center 2.412 GHz Span 30 MHz  
#Res BW 100 kHz #VBW 300 kHz #Sweep 4 ms (401 pts)

Occupied Bandwidth  
16.4872 MHz

Occ BW % Pwr 99.00 %  
x dB -6.00 dB

Transmit Freq Error -17.381 kHz  
x dB Bandwidth 16.484 MHz

## 802.11g Middle Channel

Agilent R T

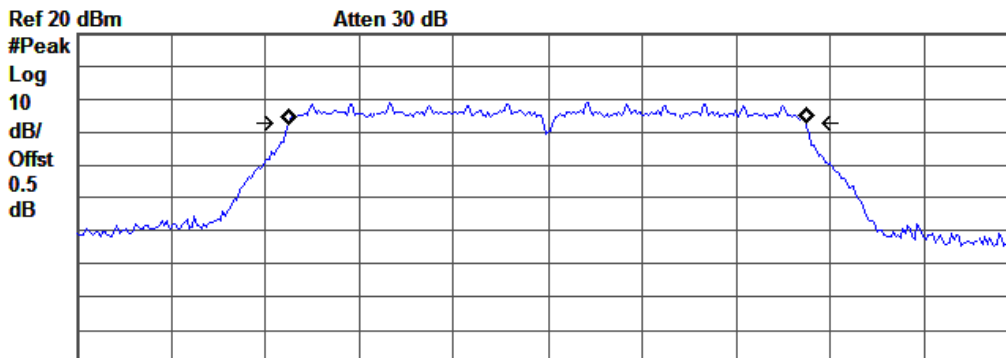

Center 2.437 GHz Span 30 MHz  
#Res BW 100 kHz #VBW 300 kHz #Sweep 4 ms (401 pts)

Occupied Bandwidth  
16.4921 MHz

Occ BW % Pwr 99.00 %  
x dB -6.00 dB

Transmit Freq Error -16.170 kHz  
x dB Bandwidth 16.465 MHz



# SIEMIC, INC.

Accessing global markets

Title: RF Test Report for Mobile Phone  
Main Model: s352  
Serial Model: N/A  
To: FCC Part 15.247: 2013, ANSI C63.4: 2009

Report No.: 14070005-FCC-R4  
Issue Date: February 25, 2014  
Page: 15 of 74  
www.siemic.com

## 802.11g High Channel

Agilent R T

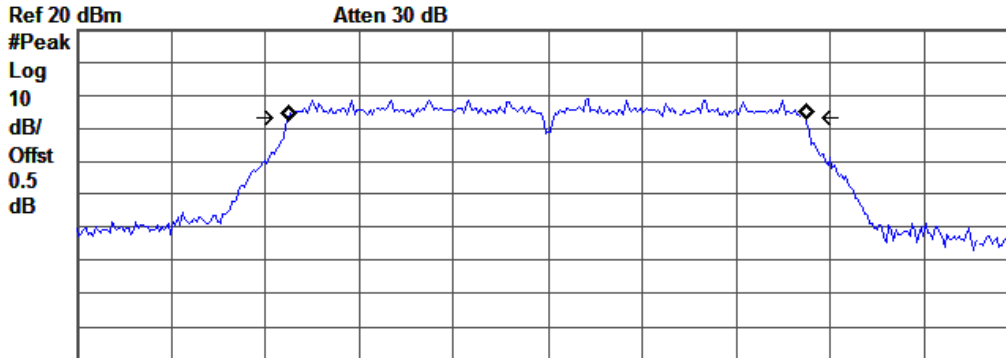

Center 2.462 GHz Span 30 MHz  
#Res BW 100 kHz #VBW 300 kHz #Sweep 4 ms (401 pts)

**Occupied Bandwidth**  
16.4769 MHz

Occ BW % Pwr 99.00 %  
x dB -6.00 dB

Transmit Freq Error -20.455 kHz  
x dB Bandwidth 16.449 MHz



## 802.11n Low Channel

Agilent R T

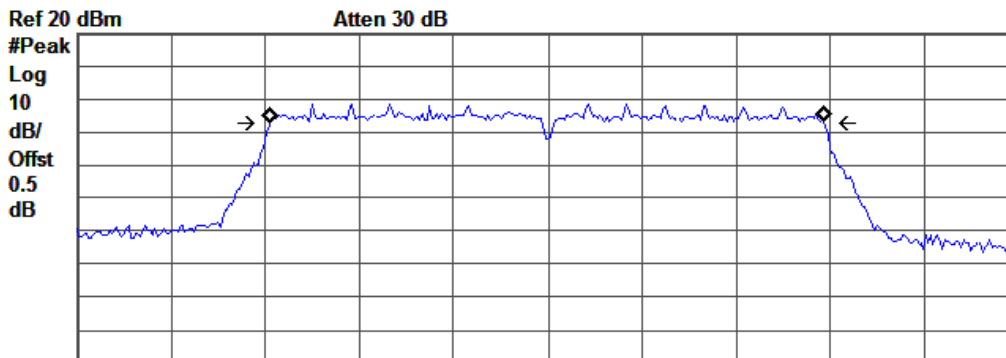

Center 2.412 GHz Span 30 MHz  
#Res BW 100 kHz #VBW 300 kHz #Sweep 4 ms (401 pts)

**Occupied Bandwidth**  
17.6074 MHz

Occ BW % Pwr 99.00 %  
x dB -6.00 dB

Transmit Freq Error -13.046 kHz  
x dB Bandwidth 17.628 MHz





# SIEMIC, INC.

Accessing global markets

Title: RF Test Report for Mobile Phone  
Main Model: s352  
Serial Model: N/A  
To: FCC Part 15.247: 2013, ANSI C63.4: 2009

Report No.: 14070005-FCC-R4  
Issue Date: February 25, 2014  
Page: 16 of 74  
www.siemic.com

## 802.11n Middle Channel

Agilent R T

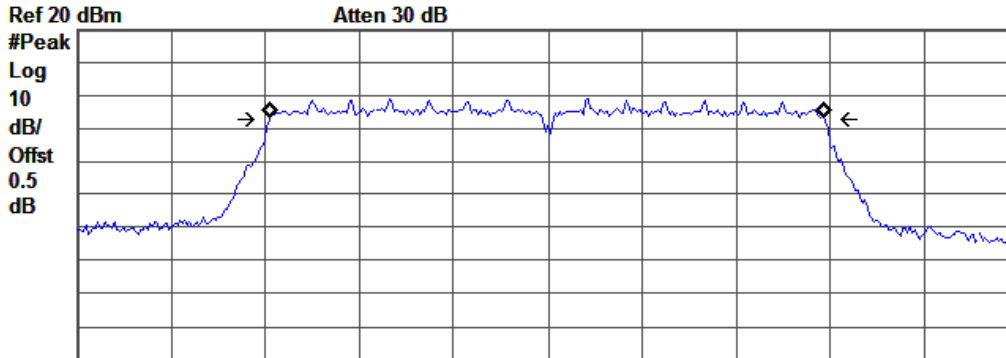

Center 2.437 GHz Span 30 MHz  
#Res BW 100 kHz #VBW 300 kHz #Sweep 4 ms (401 pts)

**Occupied Bandwidth**  
17.6107 MHz

Occ BW % Pwr 99.00 %  
x dB -6.00 dB

Transmit Freq Error -10.921 kHz  
x dB Bandwidth 17.650 MHz



## 802.11n High Channel

Agilent R T

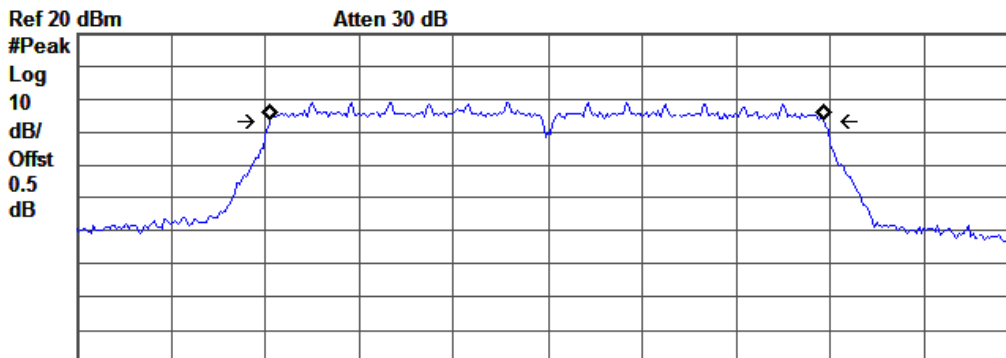

Center 2.462 GHz Span 30 MHz  
#Res BW 100 kHz #VBW 300 kHz #Sweep 4 ms (401 pts)

**Occupied Bandwidth**  
17.6148 MHz

Occ BW % Pwr 99.00 %  
x dB -6.00 dB

Transmit Freq Error -10.406 kHz  
x dB Bandwidth 17.654 MHz





The 20dB bandwidth:

802.11b Low Channel

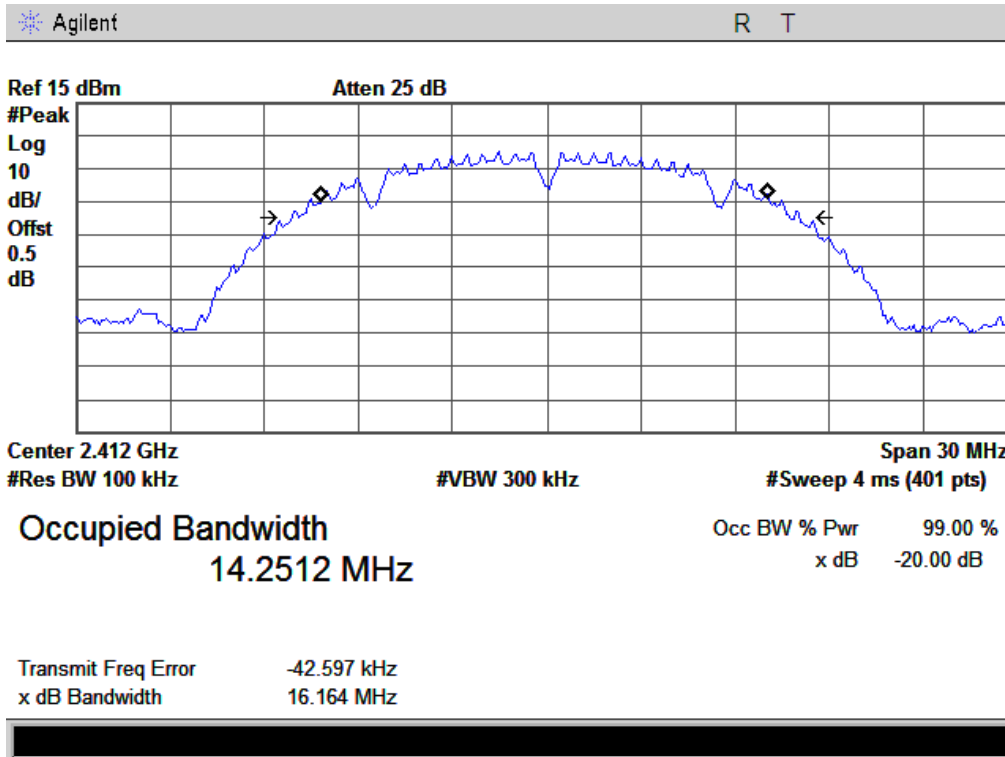

802.11b Middle Channel

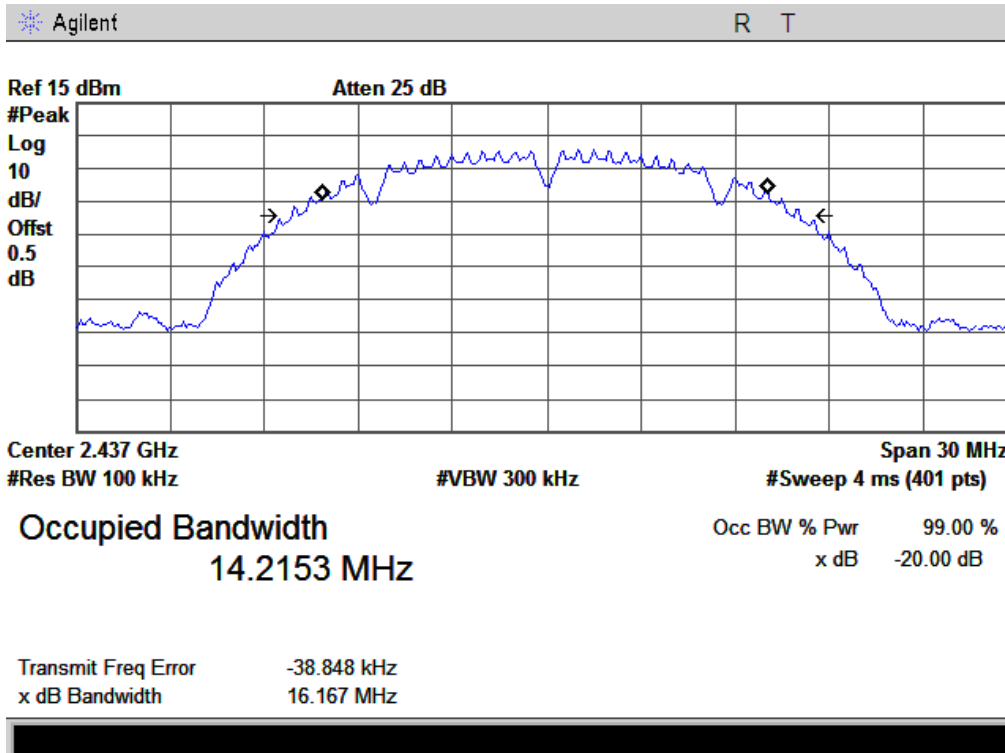

### 802.11b High Channel

Agilent R T

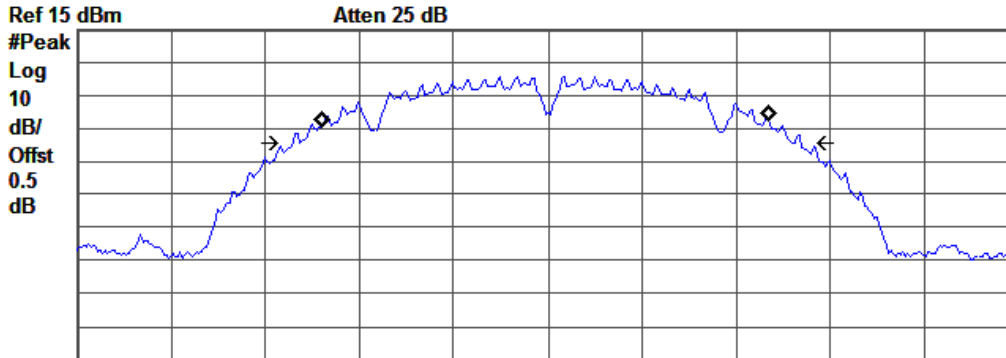

Center 2.462 GHz Span 30 MHz  
 #Res BW 100 kHz #VBW 300 kHz #Sweep 4 ms (401 pts)

**Occupied Bandwidth**  
**14.2365 MHz**

Occ BW % Pwr 99.00 %  
 x dB -20.00 dB

Transmit Freq Error -47.840 kHz  
 x dB Bandwidth 16.178 MHz

### 802.11g Low Channel

Agilent R T

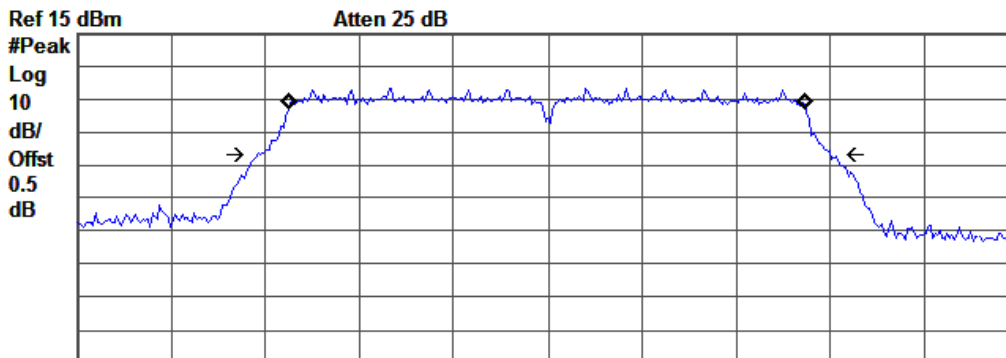

Center 2.412 GHz Span 30 MHz  
 #Res BW 100 kHz #VBW 300 kHz #Sweep 4 ms (401 pts)

**Occupied Bandwidth**  
**16.4690 MHz**

Occ BW % Pwr 99.00 %  
 x dB -20.00 dB

Transmit Freq Error -24.191 kHz  
 x dB Bandwidth 18.283 MHz

### 802.11g Middle Channel

Agilent R T

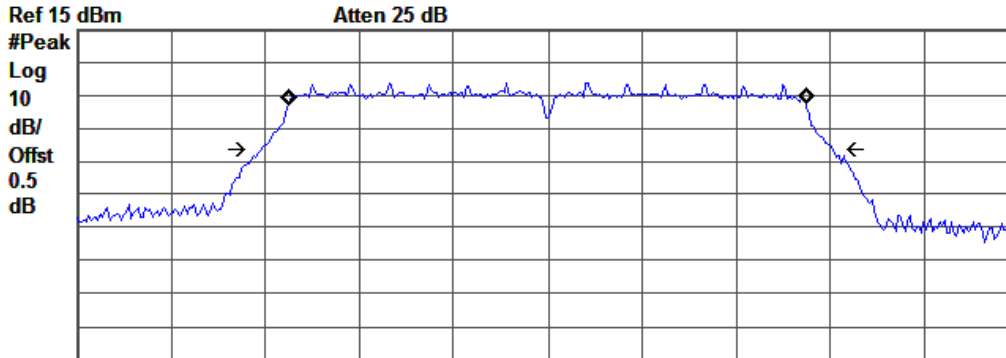

Center 2.437 GHz Span 30 MHz  
 #Res BW 100 kHz #VBW 300 kHz #Sweep 4 ms (401 pts)

**Occupied Bandwidth**  
**16.4876 MHz**

Occ BW % Pwr 99.00 %  
 x dB -20.00 dB

Transmit Freq Error -13.843 kHz  
 x dB Bandwidth 18.234 MHz

### 802.11g High Channel

Agilent R T

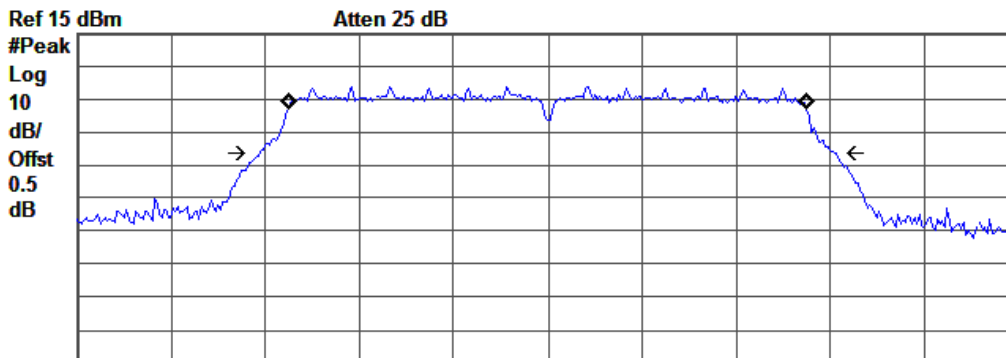

Center 2.462 GHz Span 30 MHz  
 #Res BW 100 kHz #VBW 300 kHz #Sweep 4 ms (401 pts)

**Occupied Bandwidth**  
**16.4811 MHz**

Occ BW % Pwr 99.00 %  
 x dB -20.00 dB

Transmit Freq Error -7.777 kHz  
 x dB Bandwidth 18.265 MHz

### 802.11n Low Channel

Agilent R T

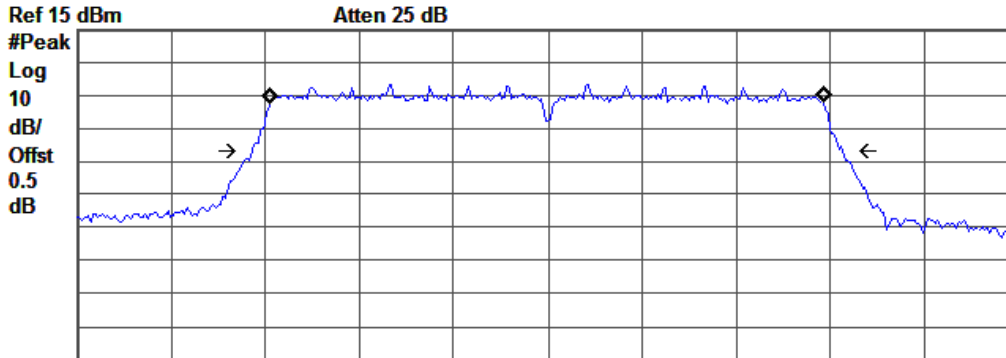

Center 2.412 GHz Span 30 MHz  
 #Res BW 100 kHz #VBW 300 kHz #Sweep 4 ms (401 pts)

**Occupied Bandwidth** Occ BW % Pwr 99.00 %  
 17.6068 MHz x dB -20.00 dB

Transmit Freq Error -18.561 kHz  
 x dB Bandwidth 18.835 MHz

### 802.11 Middle Channel

Agilent R T

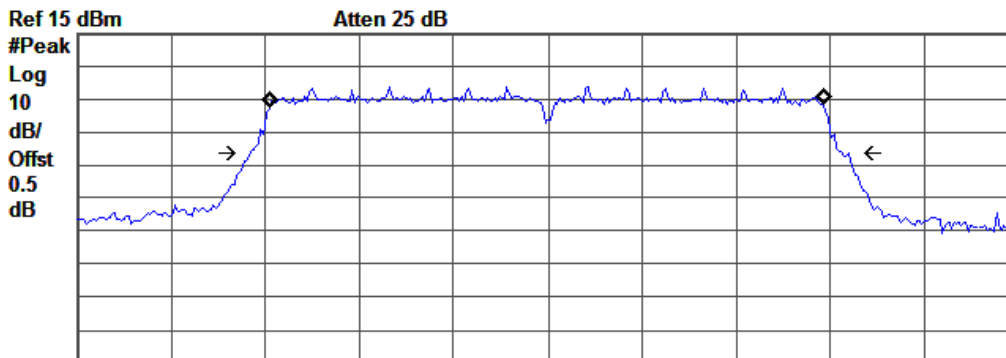

Center 2.437 GHz Span 30 MHz  
 #Res BW 100 kHz #VBW 300 kHz #Sweep 4 ms (401 pts)

**Occupied Bandwidth** Occ BW % Pwr 99.00 %  
 17.6082 MHz x dB -20.00 dB

Transmit Freq Error -23.032 kHz  
 x dB Bandwidth 19.082 MHz



# SIEMIC, INC.

Accessing global markets

Title: RF Test Report for Mobile Phone  
Main Model: s352  
Serial Model: N/A  
To: FCC Part 15.247: 2013, ANSI C63.4: 2009

Report No.: 14070005-FCC-R4  
Issue Date: February 25, 2014  
Page: 21 of 74  
www.siemic.com

## 802.11n High Channel

Agilent R T

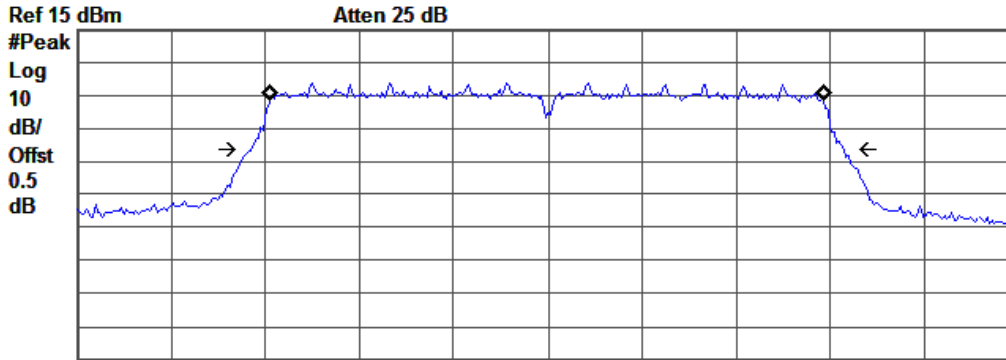

Center 2.462 GHz Span 30 MHz  
#Res BW 100 kHz #VBW 300 kHz #Sweep 4 ms (401 pts)

**Occupied Bandwidth**  
**17.6138 MHz**

Occ BW % Pwr 99.00 %  
x dB -20.00 dB

Transmit Freq Error -21.256 kHz  
x dB Bandwidth 18.864 MHz



## **5.4 §15.247(b) (3) - Conducted Maximum Output Power**

1. Conducted Measurement  
EUT was set for low, mid, high channel with modulated mode and highest RF output power.  
The spectrum analyzer was connected to the antenna terminal.
2. Conducted Emissions Measurement Uncertainty  
All test measurements carried out are traceable to national standards. The uncertainty of the measurement at a confidence level of approximately 95% (in the case where distributions are normal), with a coverage factor of 2, in the range 30MHz – 40GHz is  $\pm 1.5$ dB.
3. Environmental Conditions

Temperature	26°C
Relative Humidity	50%
Atmospheric Pressure	1019mbar
4. Test date : November 06, 2013  
Tested By : Kahn Yang

### **Standard Requirement:**

#### **Maximum Peak Conducted Output Power**

The following procedures can be used to determine the maximum peak conducted output power of a DTS EUT.

#### **Maximum Conducted Output Power**

§15.247(b)(3) permits the maximum (average) conducted output power to be measured as an alternative to the maximum peak conducted output power for demonstrating compliance to the limit. When these procedures are utilized, the power is referenced to the emission bandwidth (EBW) rather than the DTS bandwidth (see Section 2.0 for definitions).

When using a spectrum/signal analyzer to perform these measurements, it must be capable of utilizing a number of measurement points in each sweep that is greater than or equal to twice the span/RBW in order to ensure bin-to-bin spacing of  $\leq RBW/2$  so that narrowband signals are not lost between frequency bins.

The ideal method for measuring the maximum (average) conducted output power is with the EUT is configured to transmit continuously (duty cycle  $\geq 98\%$ ) at its maximum power control level. However, when this condition cannot be realized, video triggering or signal gating can be used to ensure that the measurements are performed only during periods when the EUT is transmitting at its maximum power control level. An option is also provided that can be used when none of the above requirements can be met with the available measurement instrumentation.

### **Procedures:**

#### **Measurement Procedure PK:**

This procedure should only be used when the maximum available RBW of the spectrum/signal analyzer is less than the DTS bandwidth.

1. Set the RBW = maximum available (at least 1 MHz).
2. Set the VBW = 3 x RBW or maximum available setting (must be  $\geq RBW$ ).
3. Set the span to fully encompass the DTS bandwidth.
4. Detector = peak.
5. Sweep time = auto couple.
6. Trace mode = max hold.
7. Allow trace to fully stabilize.
8. Use the spectrum analyzer's band/channel power measurement function with the band limits set equal to the DTS bandwidth edges (for some analyzers, this may require a manual override to ensure use of peak detector). If the spectrum analyzer does not have a band power function, sum the spectrum levels (in linear power units) at intervals equal to the RBW extending across the DTS channel bandwidth.

#### **Measurement Procedure AVG:**

This procedure should be used with an RMS power averaging detector; however, a sample detector can be used when an RMS detector is not available. This is the baseline method for measuring the maximum (average) conducted output power.

1. Set the analyzer span to a minimum of 1.5 times the EBW.
2. Set the RBW = 1 MHz.
3. Set the VBW  $\geq 3$  MHz.
4. Ensure that the number of measurement points in the sweep  $\geq 2$  x span/RBW.
5. Sweep time = auto couple.

6. Detector = power averaging (RMS) or sample detector when RMS not available.
7. Employ trace averaging in power averaging (RMS) mode over a minimum of 100 traces.
8. Use the spectrum analyzer's band power measurement function with band limits set equal to the EBW band edges.

Note: If the analyzer does not have a band power function, sum the spectral levels (in linear power units) at 1 MHz intervals extending across the entire EBW.

**Test Result: Pass.**

Note: The following test data please refer to report 13070501-FCC-R4.

Please refer to the following tables and plots.

**The Peak Power**

Channel	Channel Frequency (MHz)	Data Rate (Mbps)	PK Output Power (dBm)	AV Output Power (dBm)	Limit (dBm)
<b>802.11b mode</b>					
Low	2412	1	12.21	9.42	30
Middle	2437	1	11.87	9.50	30
High	2462	1	12.88	9.55	30
<b>802.11g mode</b>					
Low	2412	6	14.30	8.71	30
Middle	2437	6	14.70	9.56	30
High	2462	6	14.85	9.08	30
<b>802.11n mode</b>					
Low	2412	MCS0 (20M)	13.92	9.20	30
Middle	2437	MCS0 (20M)	14.68	9.25	30
High	2462	MCS0 (20M)	15.18	9.11	30

**The Peak Power**

**802.11b Low Channel**

Agilent R T

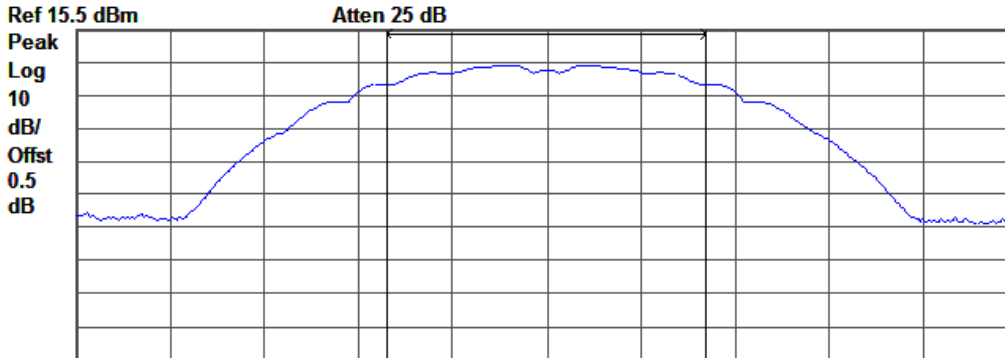

Center 2.412 GHz      Span 30 MHz  
 #Res BW 1 MHz      #VBW 3 MHz      Sweep 4 ms (401 pts)

Channel Power	Power Spectral Density
12.21 dBm / 10.1080 MHz	-57.83 dBm/Hz



**802.11b Middle Channel**

Agilent R T

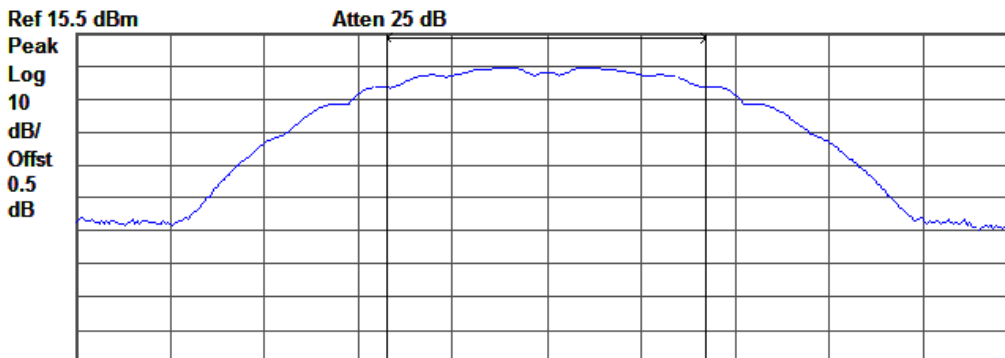

Center 2.437 GHz      Span 30 MHz  
 #Res BW 1 MHz      #VBW 3 MHz      Sweep 4 ms (401 pts)

Channel Power	Power Spectral Density
11.87 dBm / 10.0970 MHz	-58.17 dBm/Hz







# SIEMIC, INC.

Accessing global markets

Title: RF Test Report for Mobile Phone  
Main Model: s352  
Serial Model: N/A  
To: FCC Part 15.247: 2013, ANSI C63.4: 2009

Report No.: 14070005-FCC-R4  
Issue Date: February 25, 2014  
Page: 25 of 74  
www.siemic.com

## 802.11b High Channel

Agilent R T

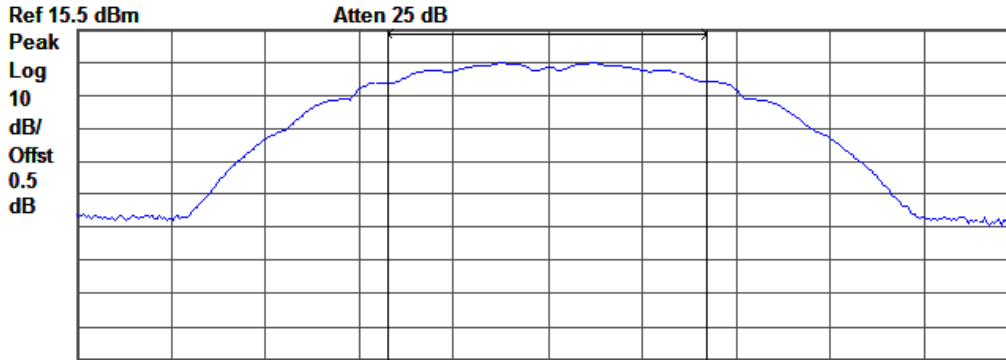

Center 2.462 GHz Span 30 MHz  
#Res BW 1 MHz #VBW 3 MHz Sweep 4 ms (401 pts)

Channel Power

12.88 dBm / 10.0960 MHz

Power Spectral Density

-57.16 dBm/Hz



## 802.11g Low Channel

Agilent R T

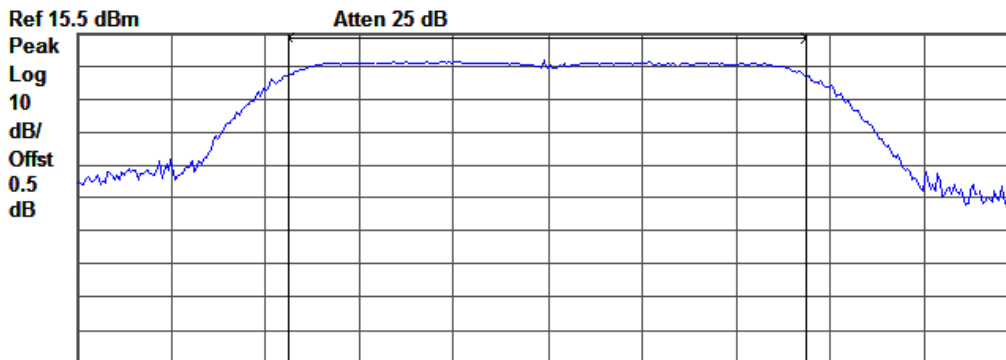

Center 2.412 GHz Span 30 MHz  
#Res BW 1 MHz #VBW 3 MHz Sweep 4 ms (401 pts)

Channel Power

14.30 dBm / 16.4840 MHz

Power Spectral Density

-57.87 dBm/Hz





# SIEMIC, INC.

Accessing global markets

Title: RF Test Report for Mobile Phone  
Main Model: s352  
Serial Model: N/A  
To: FCC Part 15.247: 2013, ANSI C63.4: 2009

Report No.: 14070005-FCC-R4  
Issue Date: February 25, 2014  
Page: 26 of 74  
www.siemic.com

## 802.11g Middle Channel

Agilent R T

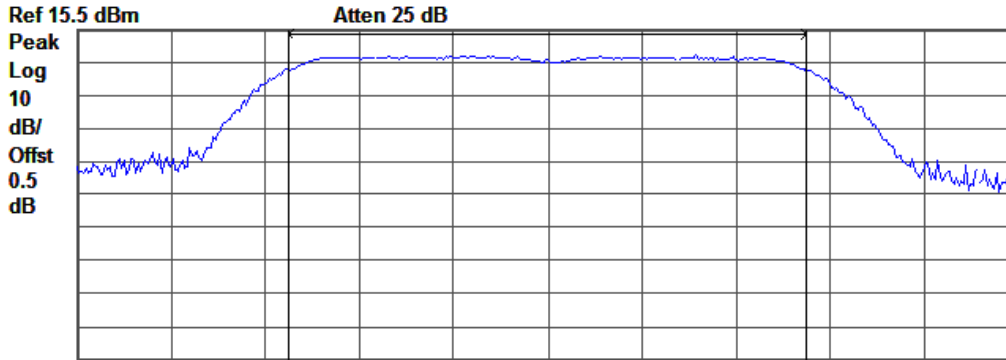

Center 2.437 GHz Span 30 MHz  
#Res BW 1 MHz #VBW 3 MHz Sweep 4 ms (401 pts)

Channel Power

14.70 dBm / 16.4650 MHz

Power Spectral Density

-57.46 dBm/Hz



## 802.11g High Channel

Agilent R T

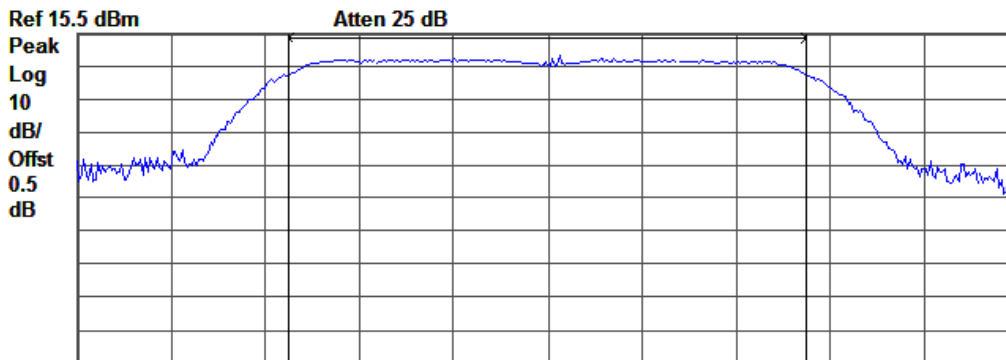

Center 2.462 GHz Span 30 MHz  
#Res BW 1 MHz #VBW 3 MHz Sweep 4 ms (401 pts)

Channel Power

14.85 dBm / 16.4490 MHz

Power Spectral Density

-57.31 dBm/Hz





# SIEMIC, INC.

Accessing global markets

Title: RF Test Report for Mobile Phone  
Main Model: s352  
Serial Model: N/A  
To: FCC Part 15.247: 2013, ANSI C63.4: 2009

Report No.: 14070005-FCC-R4  
Issue Date: February 25, 2014  
Page: 27 of 74  
www.siemic.com

## 802.11n Low Channel

Agilent R T

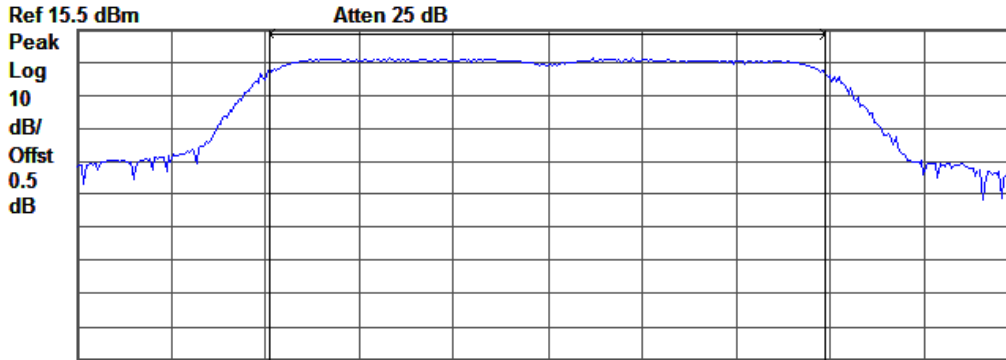

Center 2.412 GHz Span 30 MHz  
#Res BW 1 MHz #VBW 3 MHz Sweep 4 ms (401 pts)

Channel Power

13.92 dBm / 17.6280 MHz

Power Spectral Density

-58.54 dBm/Hz



## 802.11n Middle Channel

Agilent R T

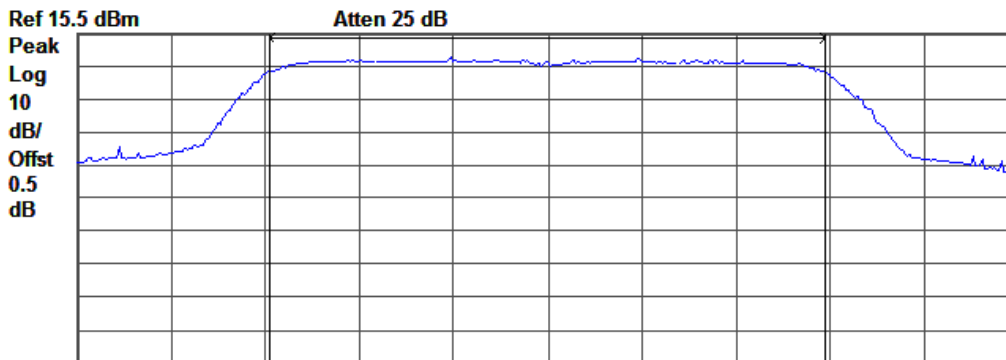

Center 2.437 GHz Span 30 MHz  
#Res BW 1 MHz #VBW 3 MHz Sweep 4 ms (401 pts)

Channel Power

14.68 dBm / 17.6500 MHz

Power Spectral Density

-57.79 dBm/Hz



### 802.11n High Channel

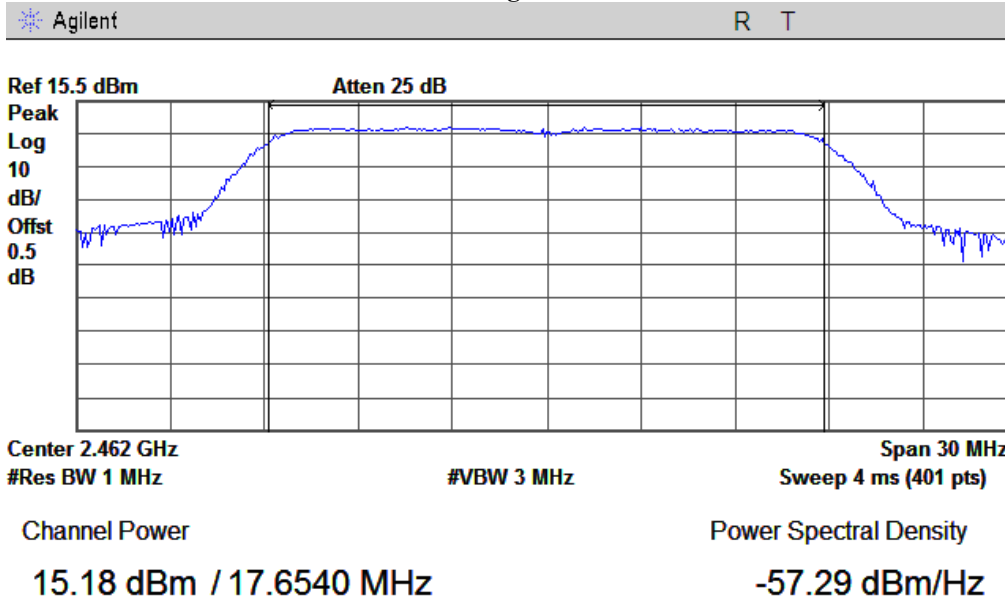

### The Average Power

### 802.11b Low Channel

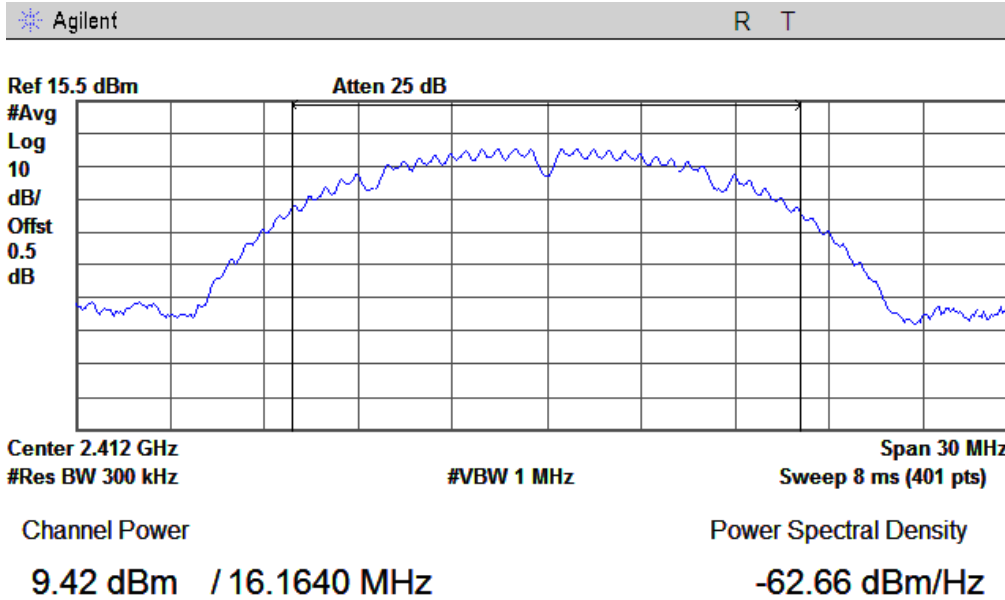



# SIEMIC, INC.

Accessing global markets

Title: RF Test Report for Mobile Phone  
Main Model: s352  
Serial Model: N/A  
To: FCC Part 15.247: 2013, ANSI C63.4: 2009

Report No.: 14070005-FCC-R4  
Issue Date: February 25, 2014  
Page: 29 of 74  
www.siemic.com

## 802.11b Middle Channel

Agilent R T

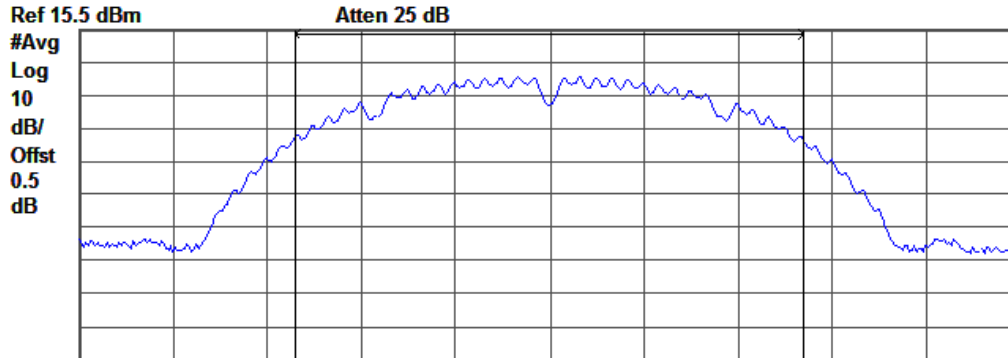

Center 2.437 GHz Span 30 MHz  
#Res BW 300 kHz #VBW 1 MHz Sweep 8 ms (401 pts)

Channel Power

9.50 dBm / 16.1670 MHz

Power Spectral Density

-62.59 dBm/Hz

## 802.11b High Channel

Agilent R T

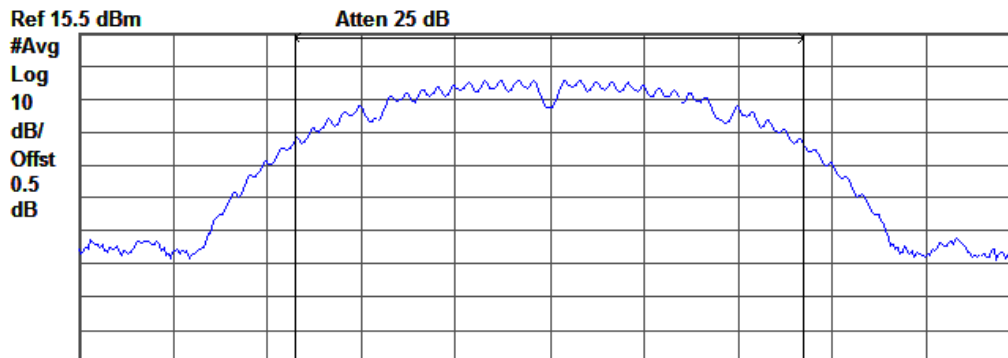

Center 2.462 GHz Span 30 MHz  
#Res BW 300 kHz #VBW 1 MHz Sweep 8 ms (401 pts)

Channel Power

9.55 dBm / 16.1780 MHz

Power Spectral Density

-62.54 dBm/Hz



# SIEMIC, INC.

Accessing global markets

Title: RF Test Report for Mobile Phone  
Main Model: s352  
Serial Model: N/A  
To: FCC Part 15.247: 2013, ANSI C63.4: 2009

Report No.: 14070005-FCC-R4  
Issue Date: February 25, 2014  
Page: 30 of 74  
www.siemic.com

## 802.11g Low Channel

Agilent R T

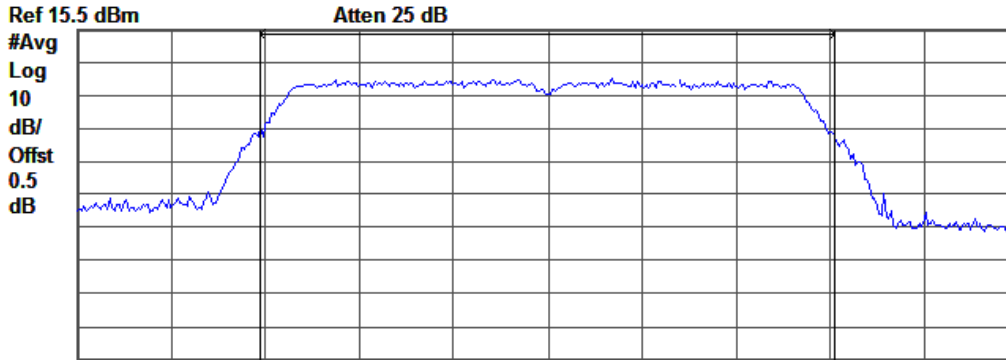

Center 2.412 GHz Span 30 MHz  
#Res BW 300 kHz #VBW 1 MHz Sweep 8 ms (401 pts)

Channel Power Power Spectral Density  
**8.71 dBm / 18.2830 MHz** **-63.91 dBm/Hz**



## 802.11g Middle Channel

Agilent R T

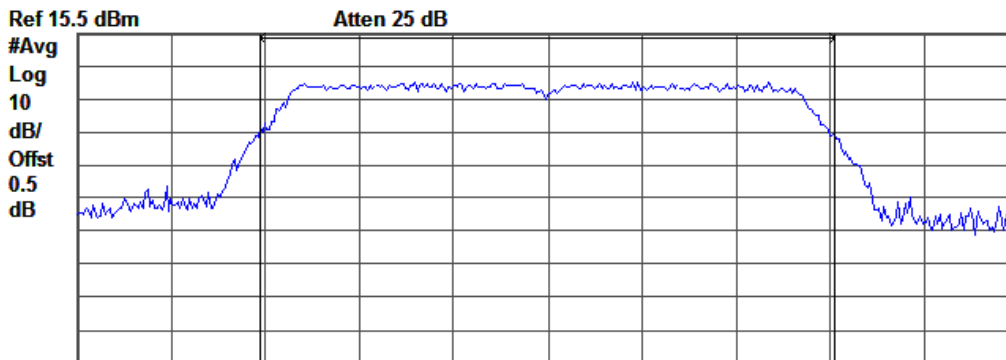

Center 2.437 GHz Span 30 MHz  
#Res BW 300 kHz #VBW 1 MHz Sweep 8 ms (401 pts)

Channel Power Power Spectral Density  
**9.56 dBm / 18.2340 MHz** **-63.05 dBm/Hz**





**SIEMIC, INC.**

Accessing global markets

Title: RF Test Report for Mobile Phone  
Main Model: s352  
Serial Model: N/A  
To: FCC Part 15.247: 2013, ANSI C63.4: 2009

Report No.: 14070005-FCC-R4  
Issue Date: February 25, 2014  
Page: 31 of 74  
www.siemic.com

### 802.11g High Channel

Agilent R T

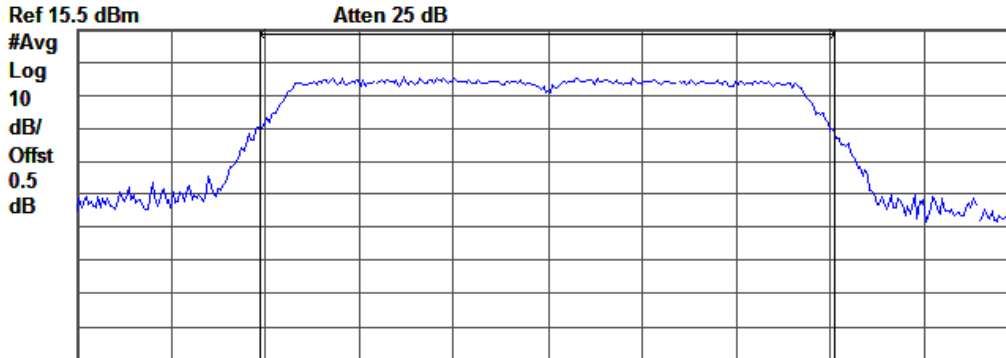

Center 2.462 GHz Span 30 MHz  
#Res BW 300 kHz #VBW 1 MHz Sweep 8 ms (401 pts)

Channel Power Power Spectral Density  
9.08 dBm / 18.2650 MHz -62.95 dBm/Hz



### 802.11n Low Channel

Agilent R T

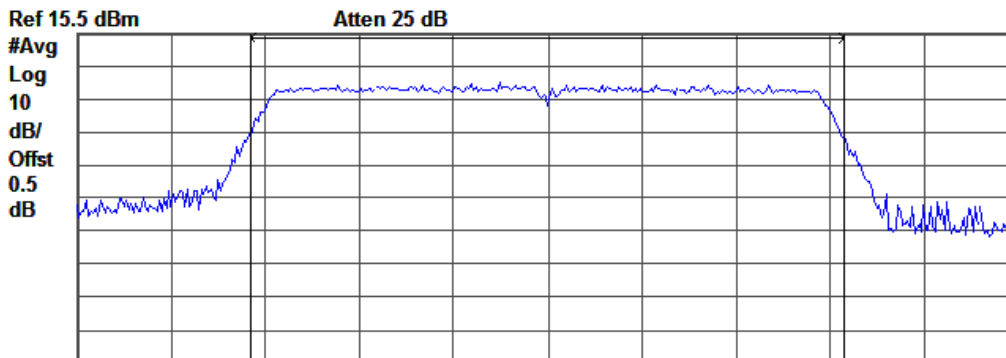

Center 2.412 GHz Span 30 MHz  
#Res BW 300 kHz #VBW 1 MHz Sweep 8 ms (401 pts)

Channel Power Power Spectral Density  
9.20 dBm / 18.8350 MHz -63.55 dBm/Hz





# SIEMIC, INC.

Accessing global markets

Title: RF Test Report for Mobile Phone  
Main Model: s352  
Serial Model: N/A  
To: FCC Part 15.247: 2013, ANSI C63.4: 2009

Report No.: 14070005-FCC-R4  
Issue Date: February 25, 2014  
Page: 32 of 74  
www.siemic.com

## 802.11n Middle Channel

Agilent R T

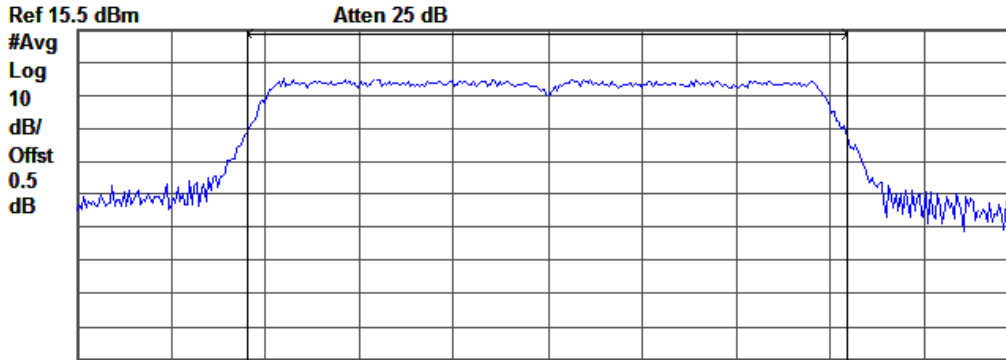

Center 2.437 GHz Span 30 MHz  
#Res BW 300 kHz #VBW 1 MHz Sweep 8 ms (401 pts)

Channel Power Power Spectral Density  
9.25 dBm / 19.0820 MHz -63.56 dBm/Hz



## 802.11n High Channel

Agilent R T

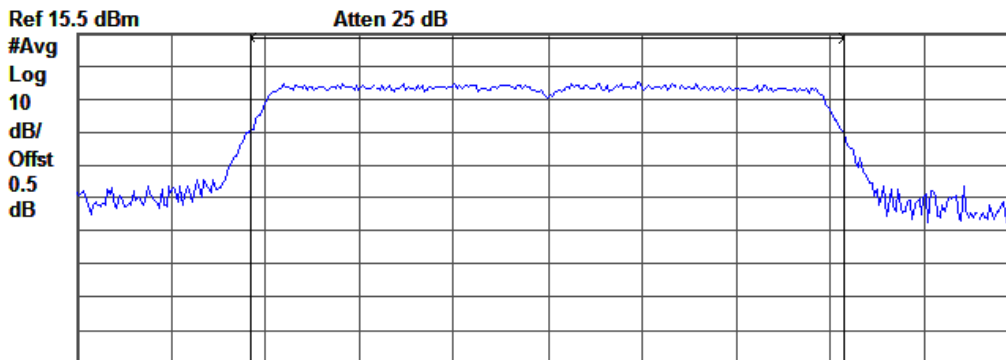

Center 2.462 GHz Span 30 MHz  
#Res BW 300 kHz #VBW 1 MHz Sweep 8 ms (401 pts)

Channel Power Power Spectral Density  
9.11 dBm / 18.8640 MHz -63.65 dBm/Hz





## **5.5 §15.247(e) - Power Spectral Density**

1. **Conducted Measurement**  
 EUT was set for low, mid, high channel with modulated mode and highest RF output power.  
 The spectrum analyzer was connected to the antenna terminal.
2. **Environmental Conditions**

Temperature	25°C
Relative Humidity	50%
Atmospheric Pressure	1019mbar
3. **Conducted Emissions Measurement Uncertainty**  
 All test measurements carried out are traceable to national standards. The uncertainty of the measurement at a confidence level of approximately 95% (in the case where distributions are normal), with a coverage factor of 2, in the range 30MHz – 40GHz is ±1.5dB.
4. **Test date :** November 05, 2013  
**Tested By :** Kahn Yang

### **Requirement(s):**

A conducted power spectral density (PSD) limit of 8 dBm in any 3 kHz band segment within the DTS bandwidth is specified during any time interval of continuous transmission. By rule, the same method as used to determine the conducted output power shall be used to determine the power spectral density (i.e., if maximum peak conducted output power was measured then the peak PSD procedure shall be used and if maximum conducted output power was measured then the average PSD procedure shall be used).

If the average PSD is measured with a power averaging (RMS) detector or a sample detector, then the spectrum analyzer must be capable of utilizing a number of measurement points in each sweep that is greater than or equal to twice the span/RBW in order to ensure bin-to-bin spacing of  $\leq RBW/2$  so that narrowband signals are not lost between frequency bins.

### **Procedures:**

This procedure must be used if maximum peak conducted output power was used to demonstrate compliance to the fundamental output power limit, and is optional if the maximum (average) conducted output power was used to demonstrate compliance.

1. Set analyzer center frequency to DTS channel center frequency.
2. Set the span to 1.5 times the DTS channel bandwidth.
3. Set the RBW  $\geq 3$  kHz.
4. Set the VBW  $\geq 3 \times$  RBW.
5. Detector = peak.
6. Sweep time = auto couple.
7. Trace mode = max hold.
8. Allow trace to fully stabilize.
9. Use the peak marker function to determine the maximum amplitude level.
10. If measured value exceeds limit, reduce RBW (no less than 3 kHz) and repeat.

### **Test Result: Pass.**

Note: The following test data please refer to report 13070501-FCC-R4.

Please refer to the following tables and plots.

Channel	Frequency (MHz)	Data Rate	PSD (dBm)	Limit (dBm)
<b>802.11b mode</b>				
Low	2412	1	0.440	8
Middle	2437	1	0.595	8
High	2462	1	0.735	8
<b>802.11g mode</b>				
Low	2412	6	-1.628	8
Middle	2437	6	-1.297	8
High	2462	6	-0.951	8
<b>802.11n mode</b>				
Low	2412	MCS0	-1.616	8
Middle	2437	MCS0	-1.278	8
High	2462	MCS0	-0.869	8

**Power Spectral Density, 802.11b Low Channel**

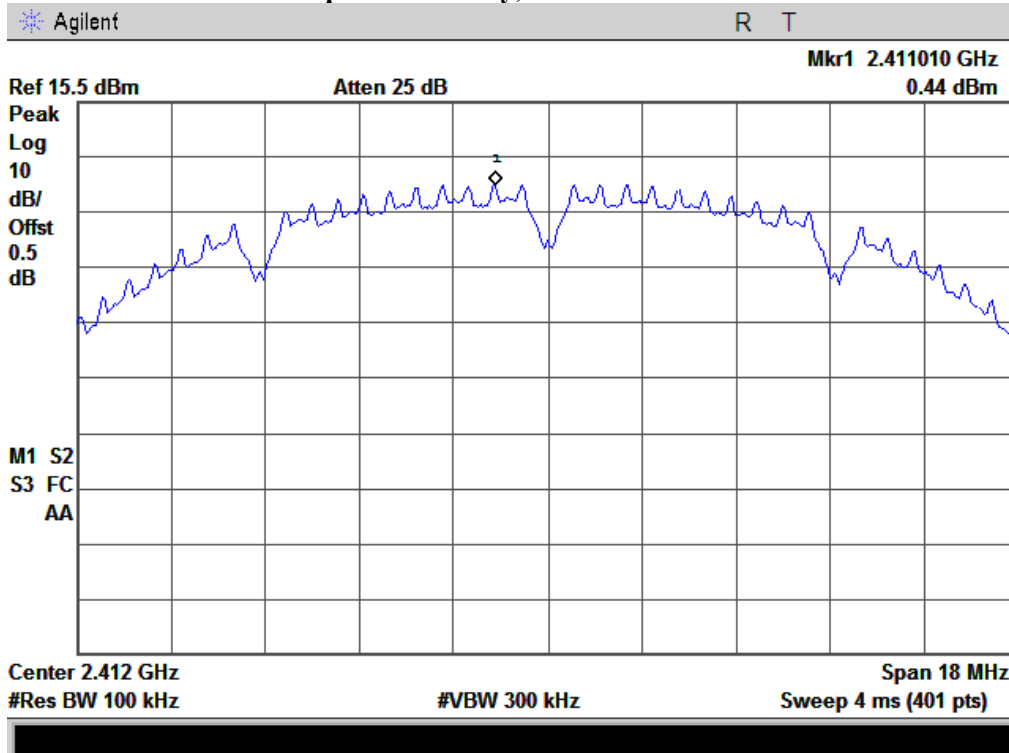



# SIEMIC, INC.

Accessing global markets

Title: RF Test Report for Mobile Phone  
Main Model: s352  
Serial Model: N/A  
To: FCC Part 15.247: 2013, ANSI C63.4: 2009

Report No.: 14070005-FCC-R4  
Issue Date: February 25, 2014  
Page: 35 of 74  
www.siemic.com

## Power Spectral Density, 802.11b Middle Channel

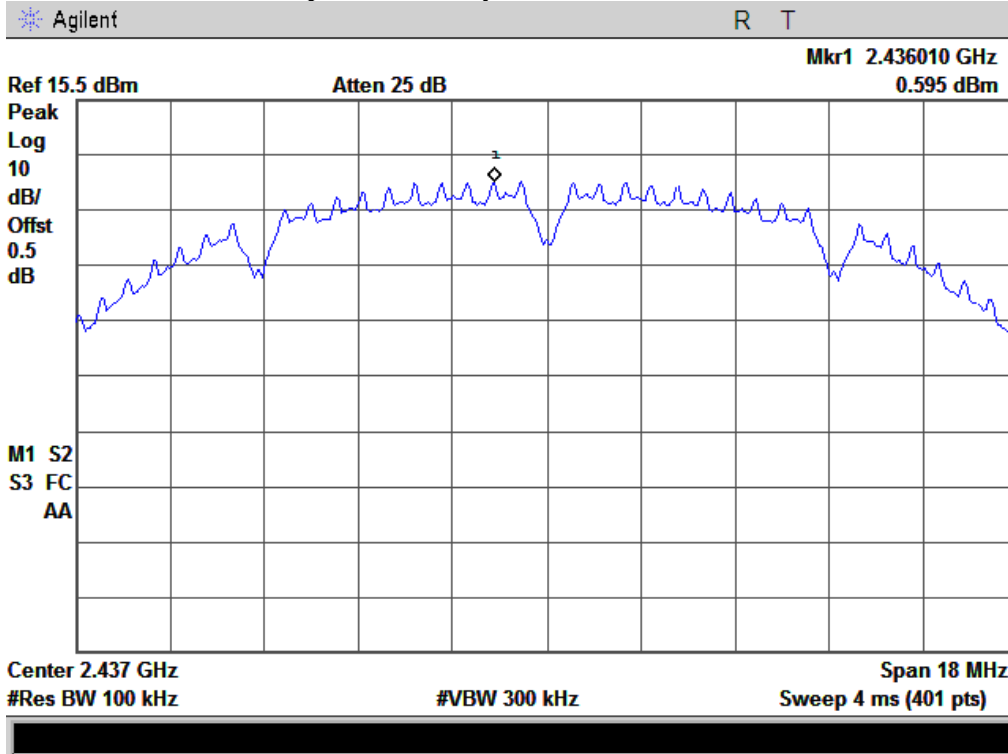

## Power Spectral Density, 802.11b High Channel

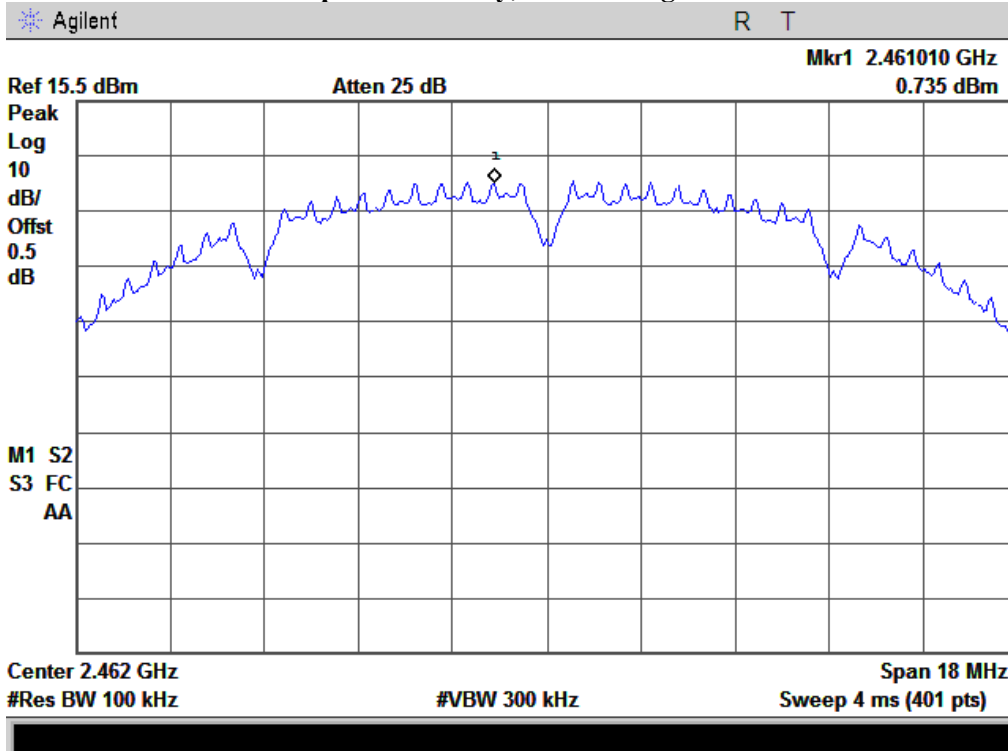



**SIEMIC, INC.**

Accessing global markets

Title: RF Test Report for Mobile Phone  
Main Model: s352  
Serial Model: N/A  
To: FCC Part 15.247: 2013, ANSI C63.4: 2009

Report No.: 14070005-FCC-R4  
Issue Date: February 25, 2014  
Page: 36 of 74  
www.siemic.com

### Power Spectral Density, 802.11g Low Channel

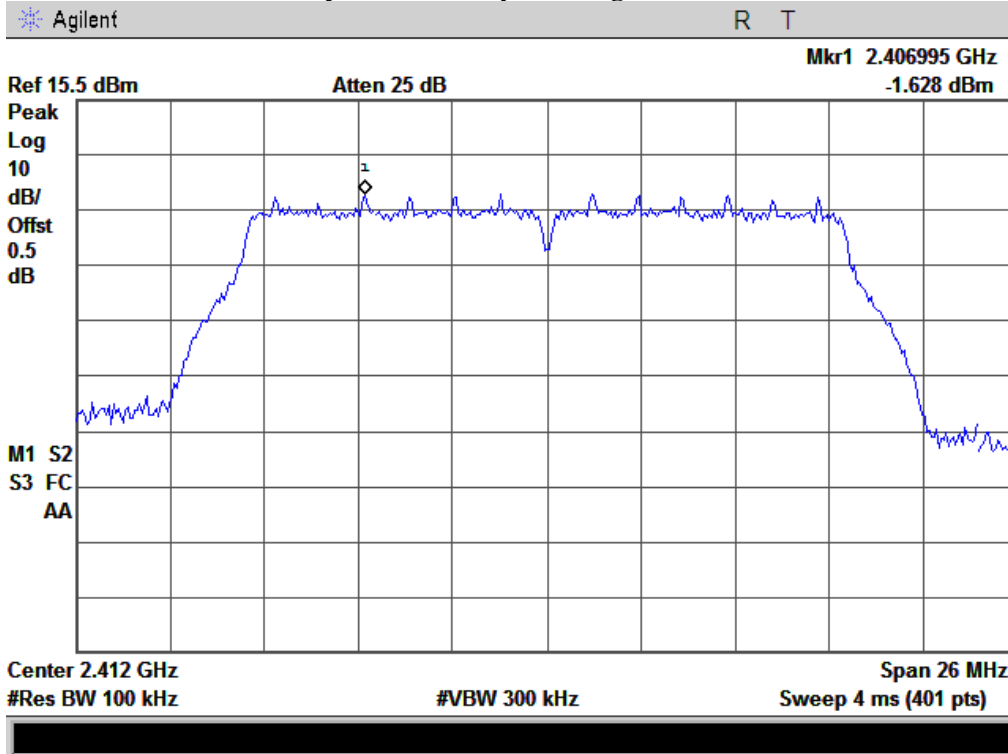

### Power Spectral Density, 802.11g Middle Channel

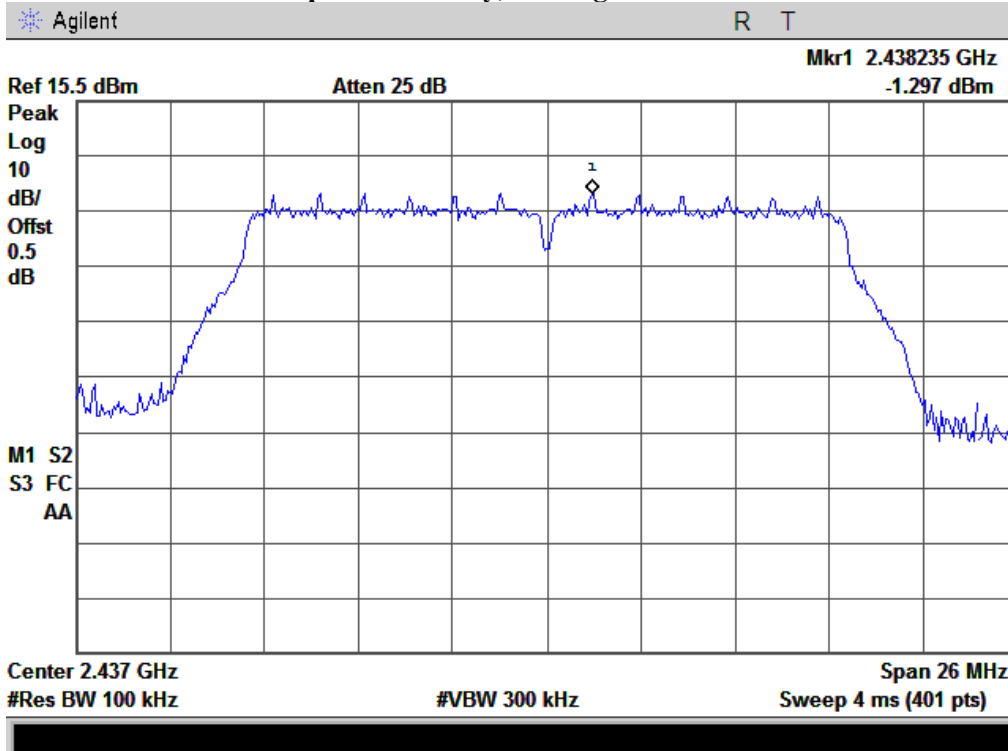



**SIEMIC, INC.**

Accessing global markets

Title: RF Test Report for Mobile Phone  
Main Model: s352  
Serial Model: N/A  
To: FCC Part 15.247: 2013, ANSI C63.4: 2009

Report No.: 14070005-FCC-R4  
Issue Date: February 25, 2014  
Page: 37 of 74  
www.siemic.com

### Power Spectral Density, 802.11g High Channel

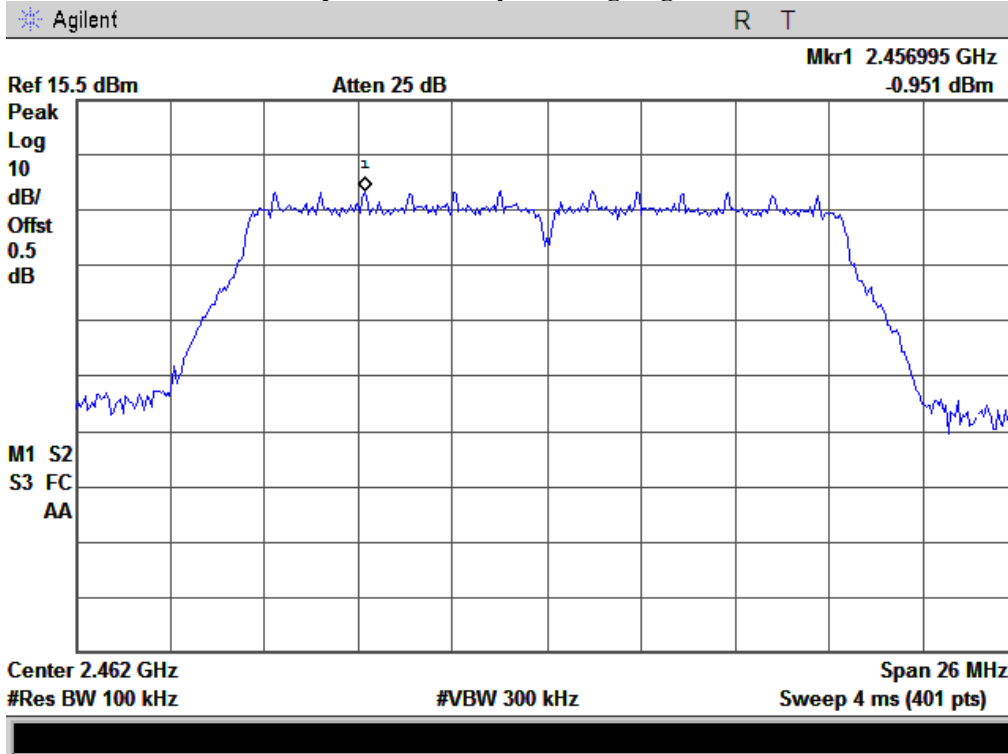

### Power Spectral Density, 802.11n Low Channel

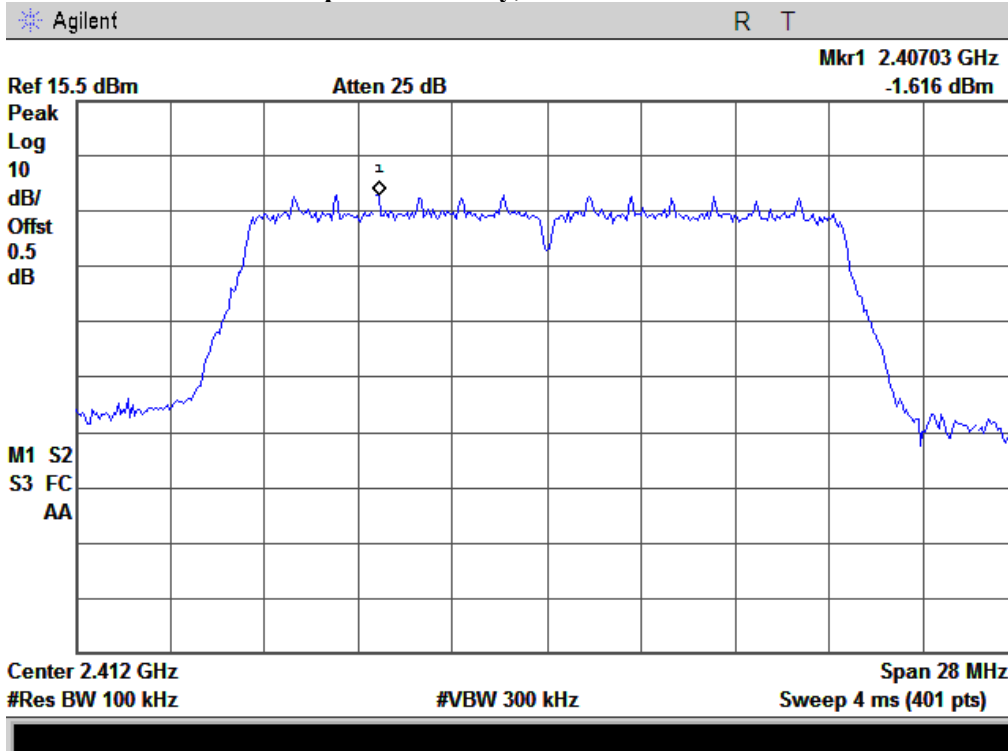



**SIEMIC, INC.**

Accessing global markets

Title: RF Test Report for Mobile Phone  
Main Model: s352  
Serial Model: N/A  
To: FCC Part 15.247: 2013, ANSI C63.4: 2009

Report No.: 14070005-FCC-R4  
Issue Date: February 25, 2014  
Page: 38 of 74  
www.siemic.com

### Power Spectral Density, 802.11n Middle Channel

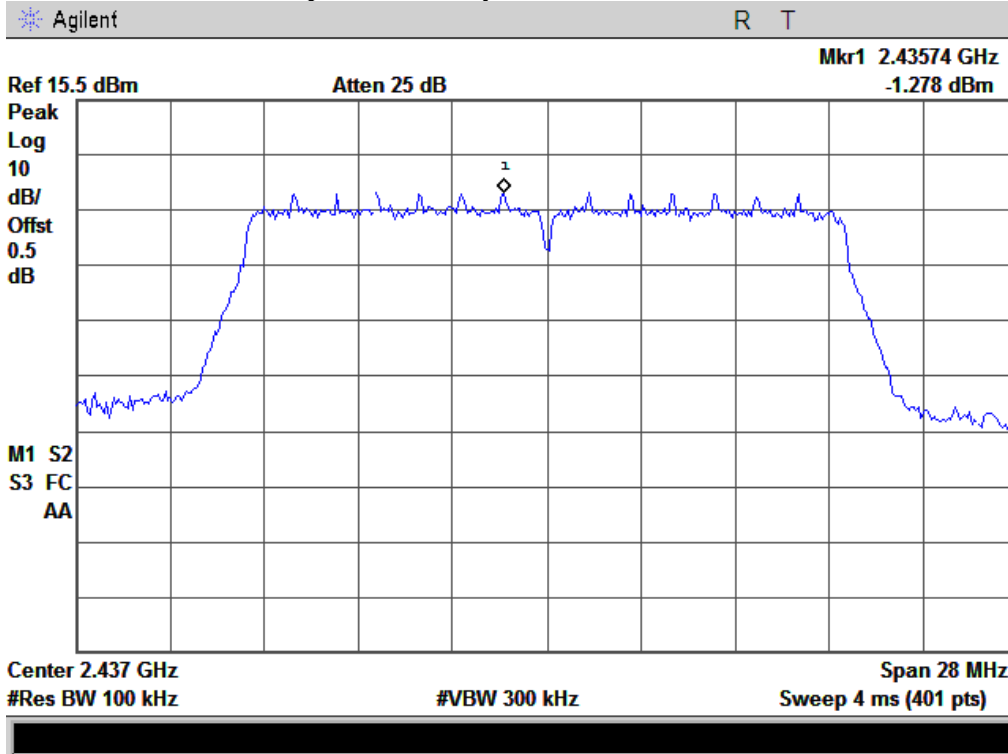

### Power Spectral Density, 802.11n High Channel

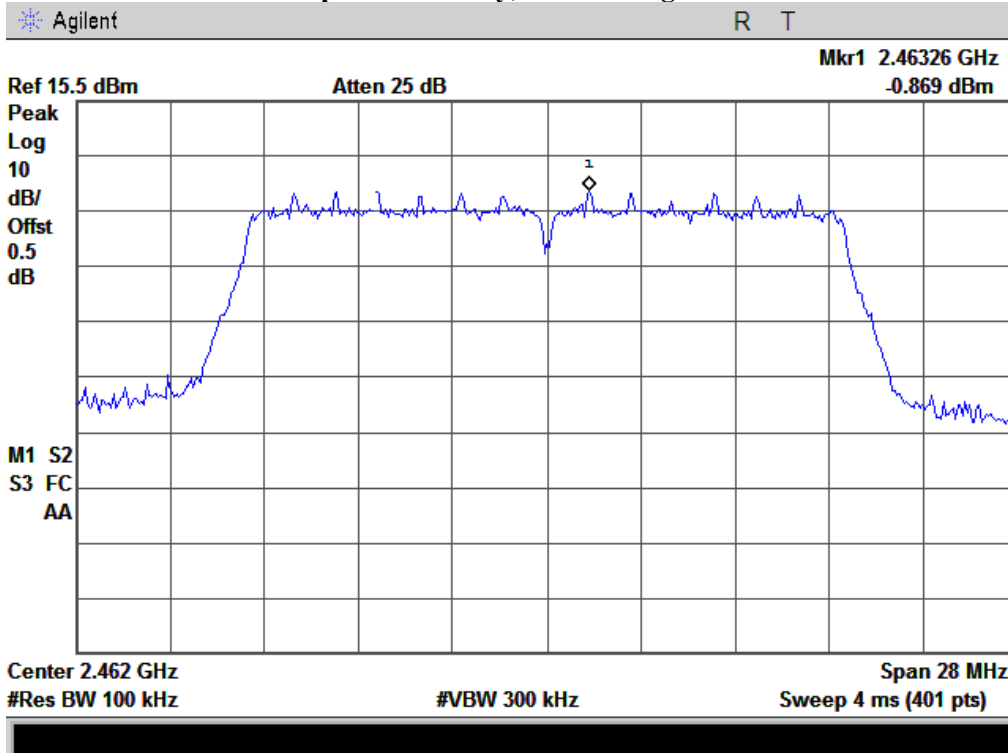

## **5.6 §15.247(d) –Band-Edge & Unwanted Emissions into Non-Restricted Frequency Bands**

1. In any 100 kHz bandwidth outside the frequency band in which the spread spectrum or digitally modulated intentional radiator is operating, the radio frequency power that is produced by the intentional radiator shall be at least 20 dB below that in the 100 kHz bandwidth within the band that contains the highest level of the desired power, based on either an RF conducted or a radiated measurement, provided the transmitter demonstrates compliance with the peak conducted power limits. If the transmitter complies with the conducted power limits based on the use of RMS averaging over a time interval, as permitted under paragraph (b)(3) of this section, the attenuation required under this paragraph shall be 30 dB instead of 20 dB. Attenuation below the general limits specified in §15.209(a) is not required. In addition, radiated emissions which fall in the restricted bands, as defined in §15.205(a), must also comply with the radiated emission limits specified in §15.209(a) (see §15.205(c))
  
2. Environmental Conditions
 

Temperature	25 °C
Relative Humidity	50%
Atmospheric Pressure	1019mbar
  
3. Test date : November 04, 2013  
 Tested By : Kahn Yang

### **Requirement(s):**

#### **Band-Edge Measurements**

An additional consideration when performing conducted measurements of restricted band emissions is that unwanted emissions radiating from the EUT cabinet, control circuits, power leads, or intermediate circuit elements will likely go undetected in a conducted measurement configuration. To address this concern, a radiated test shall be performed to ensure that emissions emanating from the EUT cabinet (rather than the antenna port) also comply with the applicable limits.

For these cabinet radiated spurious emission measurements the EUT transmit antenna may be replaced with a termination matching the nominal impedance of the antenna. Procedures for performing radiated measurements are specified in ANSI C63.10. All detected emissions shall comply with the applicable limits.

#### **Procedures: (Radiated Method Only)**

1. Check the calibration of the measuring instrument using either an internal calibrator or a known signal from an external generator.
2. Position the EUT on the rotated table inside the anechoic chamber without connection to measurement instrument. Turn on the EUT and make it operate in transmitting mode. Then set it to Low Channel and High Channel within its operating range, and make sure the instrument is operated in its linear range. Repeat above procedures until all measured frequencies were complete.
3. Set band RBW=1MHz, VBW=3MHz with a convenient frequency span from band edge.
4. Find the highest point in edge frequency, and then calculated results.
5. Repeat above procedures until all measured frequencies were complete.

#### **Test Result: Pass.**

Note: The following test data please refer to report 13070501-FCC-R4.

Please refer to the following tables and plots.

### 802.11b: Band Edge, Left Side (Average)

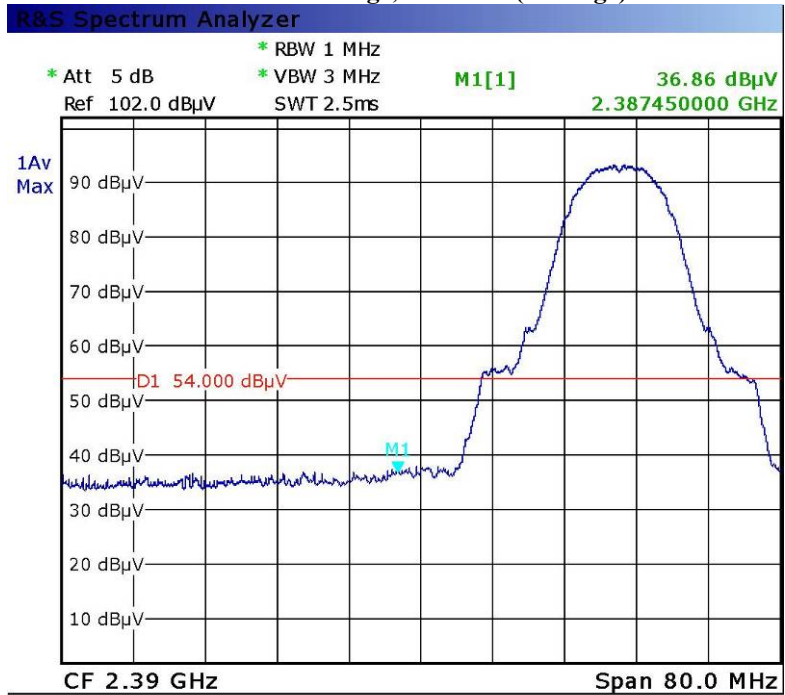

Date: 5.NOV.2013 07:56:01

### 802.11b: Band Edge, Left Side (Peak)

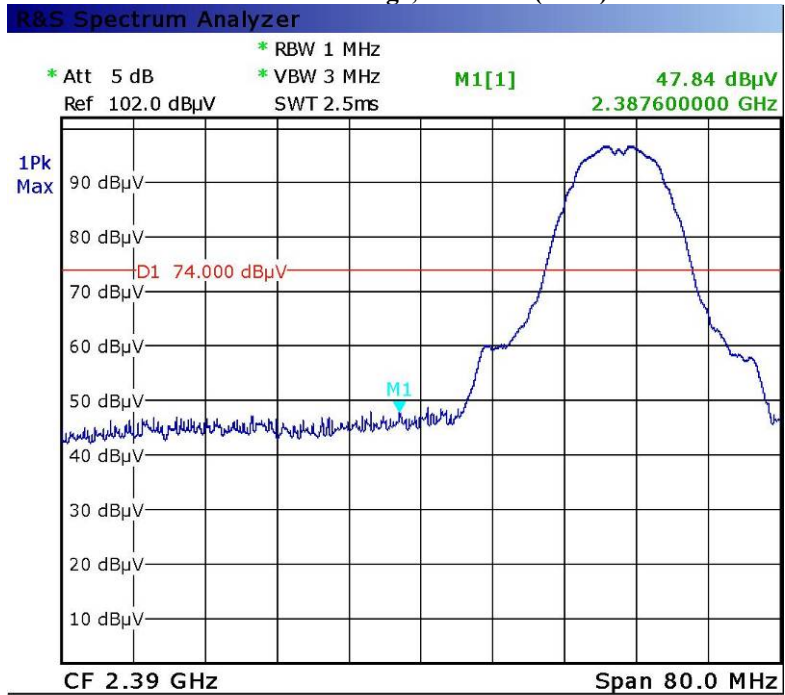

Date: 5.NOV.2013 07:42:21





**SIEMIC, INC.**

Accessing global markets

Title: RF Test Report for Mobile Phone  
Main Model: s352  
Serial Model: N/A  
To: FCC Part 15.247: 2013, ANSI C63.4: 2009

Report No.: 14070005-FCC-R4  
Issue Date: February 25, 2014  
Page: 41 of 74  
www.siemic.com

### 802.11b: Band Edge, Right Side (Average)

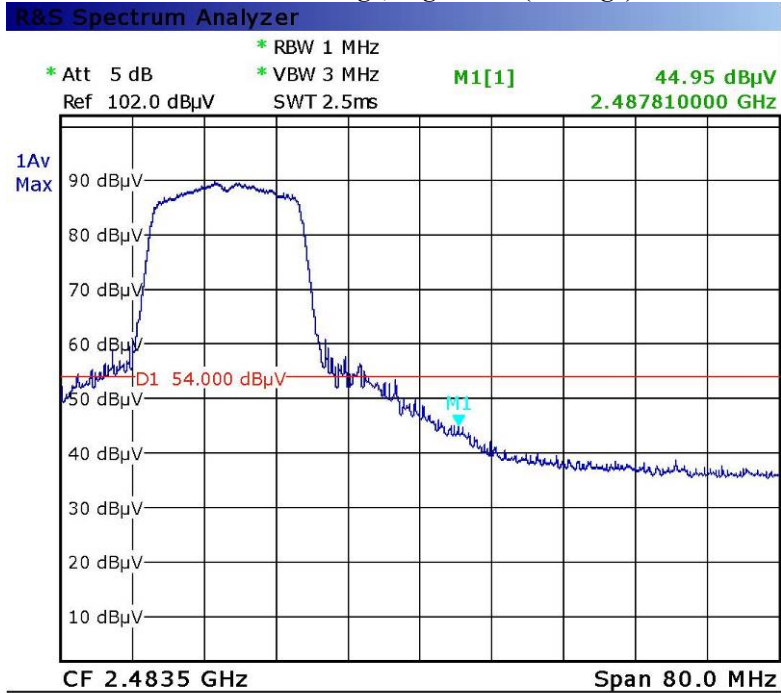

Date: 5.NOV.2013 08:08:08

### 802.11b: Band Edge, Right Side (Peak)

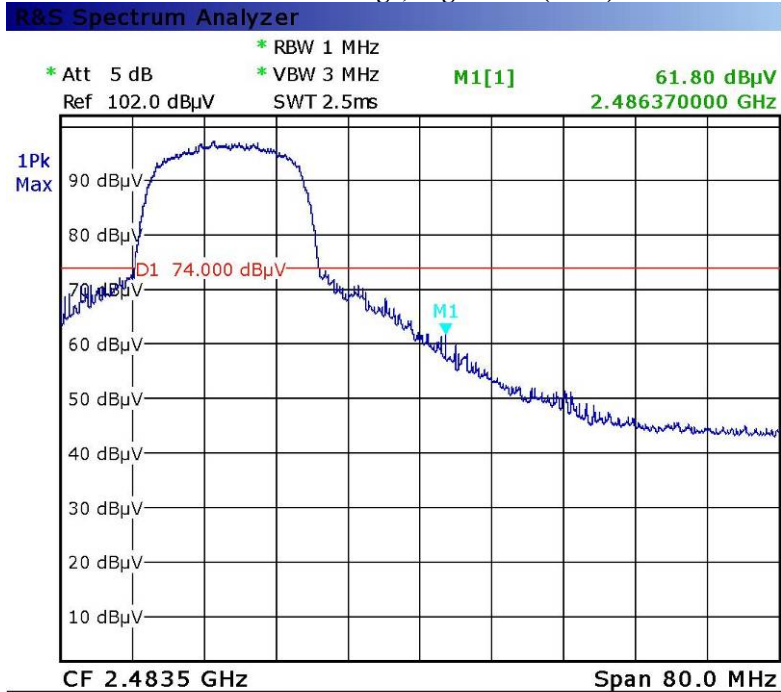

Date: 5.NOV.2013 08:12:15





**SIEMIC, INC.**

Accessing global markets

Title: RF Test Report for Mobile Phone  
Main Model: s352  
Serial Model: N/A  
To: FCC Part 15.247: 2013, ANSI C63.4: 2009

Report No.: 14070005-FCC-R4  
Issue Date: February 25, 2014  
Page: 43 of 74  
www.siemic.com

### 802.11g: Band Edge, Right Side (Average)

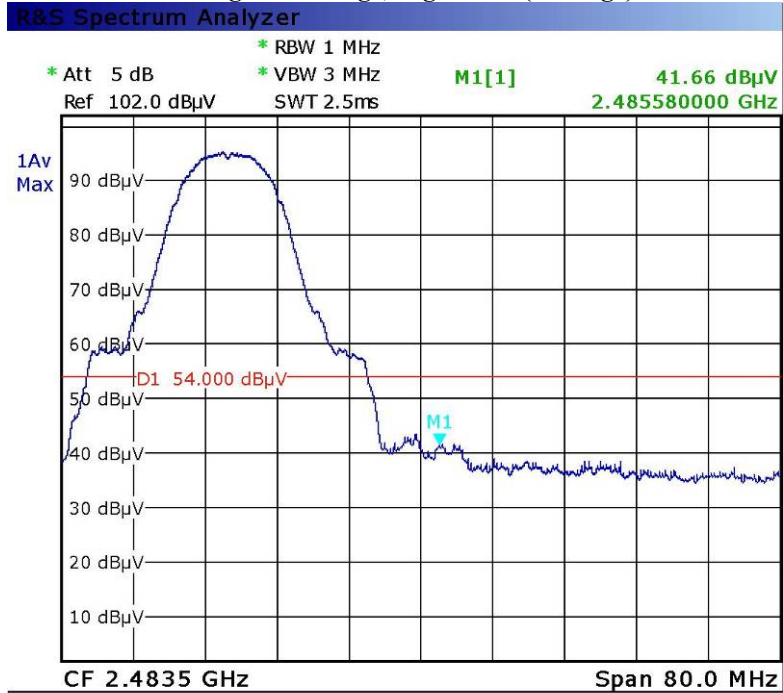

Date: 5.NOV.2013 08:14:29

### 802.11g: Band Edge, Right Side (Peak)

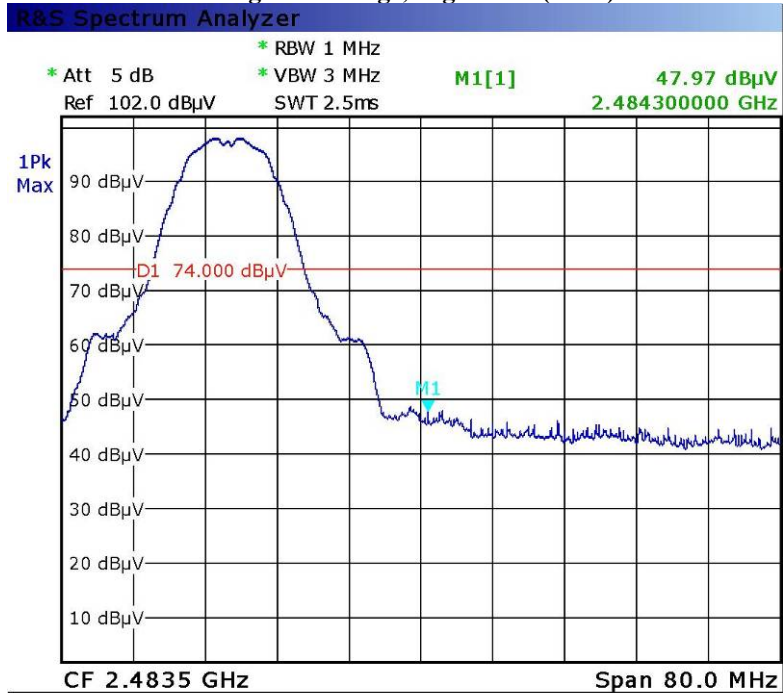

Date: 5.NOV.2013 08:13:50



**SIEMIC, INC.**

Accessing global markets

Title: RF Test Report for Mobile Phone  
Main Model: s352  
Serial Model: N/A  
To: FCC Part 15.247: 2013, ANSI C63.4: 2009

Report No.: 14070005-FCC-R4  
Issue Date: February 25, 2014  
Page: 44 of 74  
www.siemic.com

### 802.11n: Band Edge, Left Side (Average)

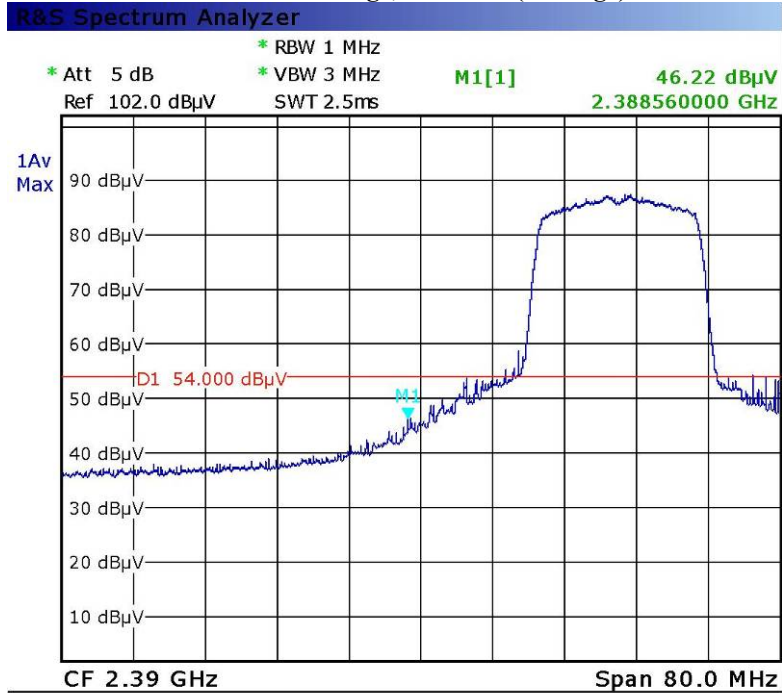

Date: 5.NOV.2013 08:01:37

### 802.11n: Band Edge, Left Side (Peak)

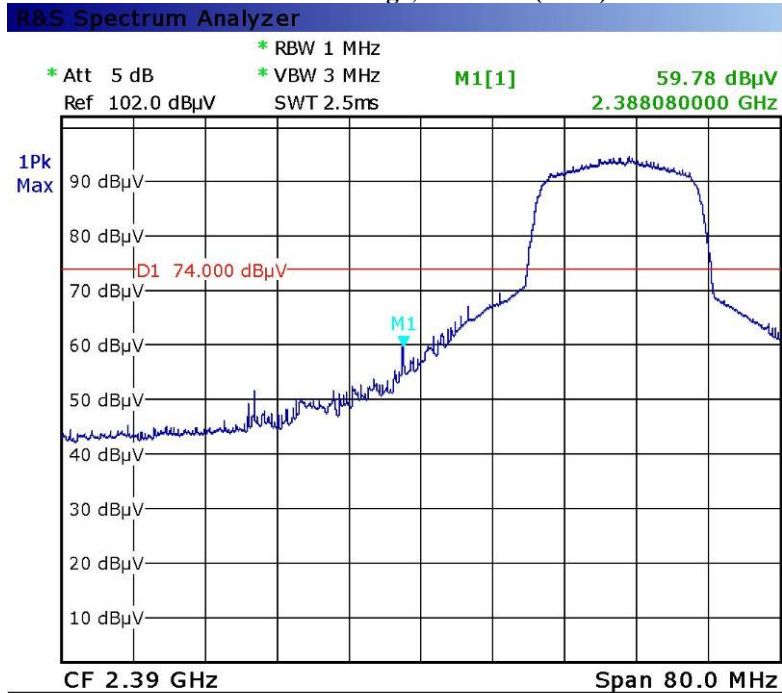

Date: 5.NOV.2013 08:02:51



**SIEMIC, INC.**

Accessing global markets

Title: RF Test Report for Mobile Phone  
Main Model: s352  
Serial Model: N/A  
To: FCC Part 15.247: 2013, ANSI C63.4: 2009

Report No.: 1407005-FCC-R4  
Issue Date: February 25, 2014  
Page: 45 of 74  
www.siemic.com

### 802.11n: Band Edge, Right Side (Average)

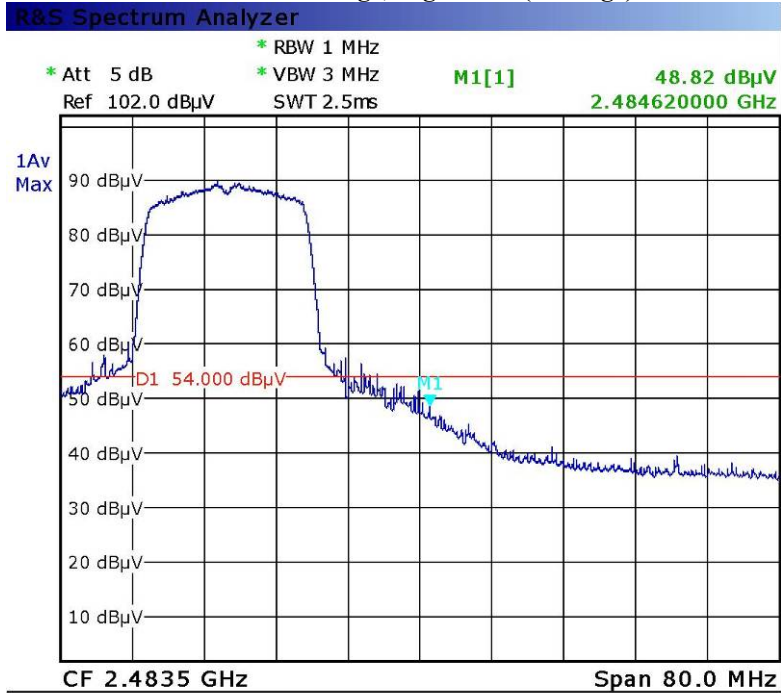

Date: 5.NOV.2013 08:06:10

### 802.11n: Band Edge, Right Side (Peak)

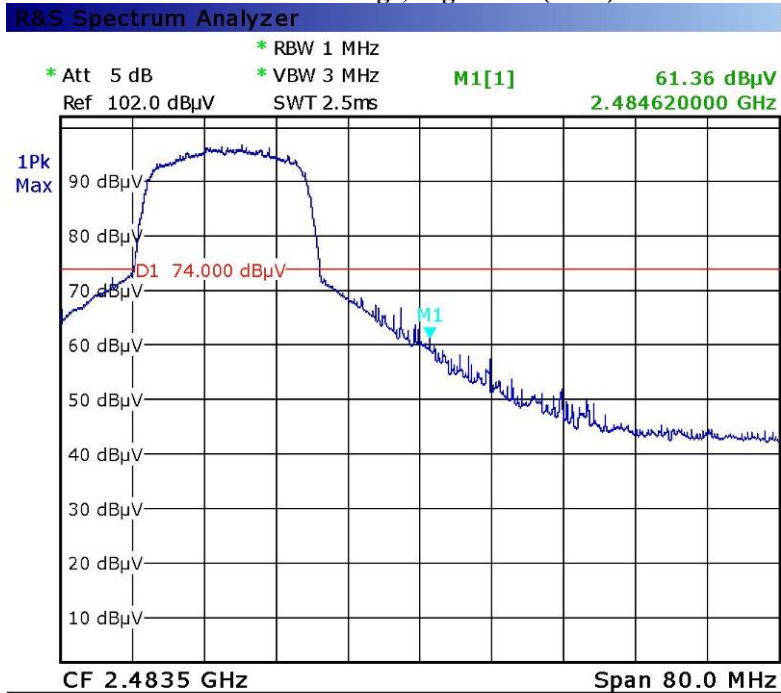

Date: 5.NOV.2013 08:04:45

## **5.7 §15.207 (a) - AC Power Line Conducted Emissions**

Requirement:

Frequency of emission (MHz)	Conducted limit (dBμV)	
	Quasi-peak	Average
0.15–0.5	66 to 56*	56 to 46*
0.5–5	56	46
5–30	60	50

\*Decreases with the logarithm of the frequency.

### **Procedures:**

- All possible modes of operation were investigated. Only the 6 worst case emissions measured, using the correct CISPR and Average detectors, are reported. All other emissions were relatively insignificant.
- A "-ve" margin indicates a PASS as it refers to the margin present below the limit line at the particular frequency.
- Conducted Emissions Measurement Uncertainty  
All test measurements carried out are traceable to national standards. The uncertainty of the measurement at a confidence level of approximately 95% (in the case where distributions are normal), with a coverage factor of 2, in the range 9kHz – 30MHz (Average & Quasi-peak) is ±3.5dB.
- Environmental Conditions
 

Temperature	22°C
Relative Humidity	55%
Atmospheric Pressure	1010mbar
- Test date: February 19, 2014  
Tested By : Kahn Yang

<b>Test Mode:</b>	<b>Transmitting Mode(Worse Case)</b>
-------------------	--------------------------------------

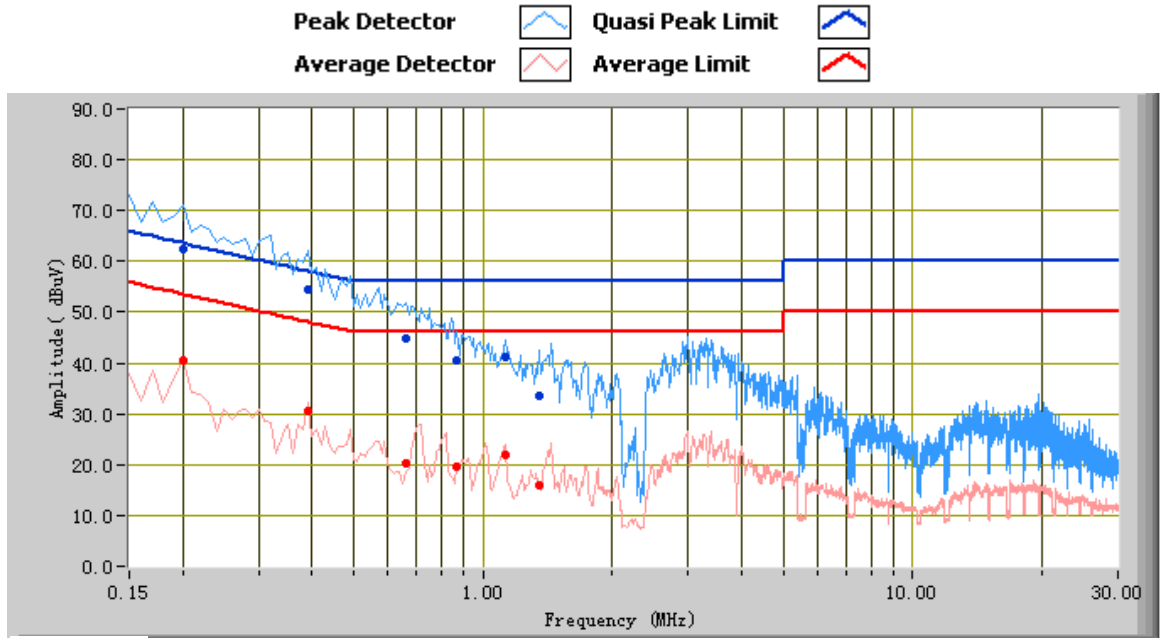

**Test Data**

**Phase Line Plot at 110Vac, 60Hz**

Frequency (MHz)	Quasi Peak (dBuV)	Limit (dBuV)	Margin (dB)	Average (dBuV)	Limit (dBuV)	Margin (dB)	Factors (dB)
0.20	62.67	63.61	-0.94	40.57	53.61	-13.04	10.10
0.39	54.56	58.06	-3.50	30.54	48.06	-17.52	10.10
0.66	44.83	56.00	-11.17	20.28	46.00	-25.72	10.10
0.87	40.38	56.00	-15.62	19.46	46.00	-26.54	10.10
1.13	41.27	56.00	-14.73	21.91	46.00	-24.09	10.10
1.35	33.50	56.00	-22.50	15.90	46.00	-30.10	10.10

<b>Test Mode:</b>	<b>Transmitting Mode(Worse Case)</b>
-------------------	--------------------------------------

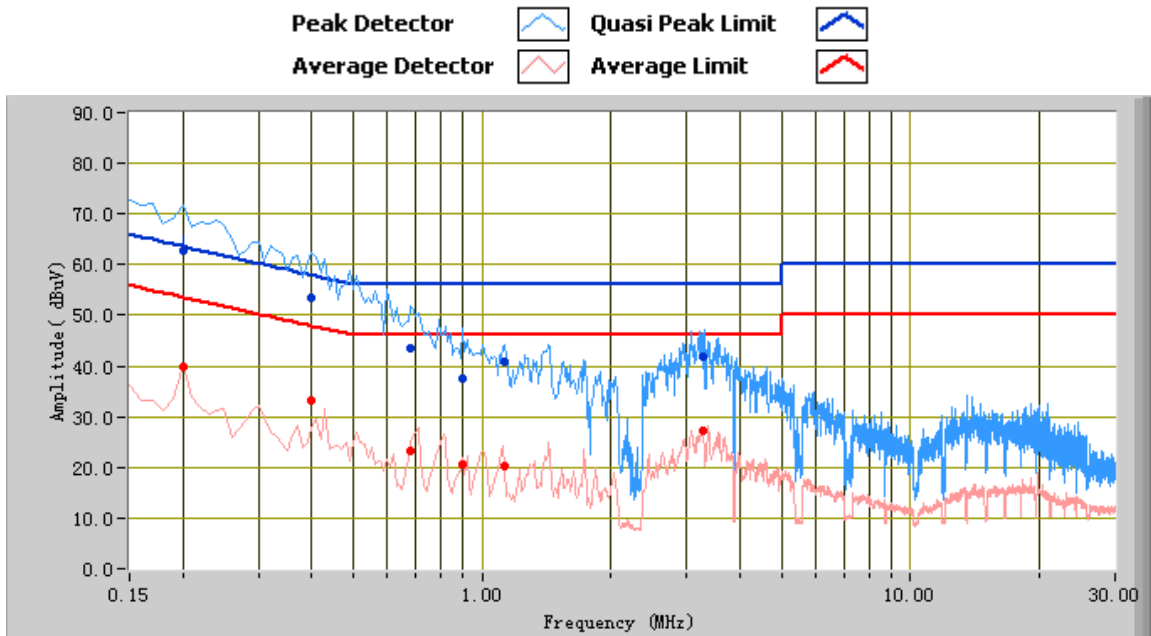

**Test Data**

**Phase Neutral Plot at 110Vac, 60Hz**

Frequency (MHz)	Quasi Peak (dBuV)	Limit (dBuV)	Margin (dB)	Average (dBuV)	Limit (dBuV)	Margin (dB)	Factors (dB)
0.20	63.20	63.61	-0.41	39.69	53.61	-13.92	10.10
0.40	53.34	57.85	-4.51	33.21	47.85	-14.64	10.10
0.68	43.41	56.00	-12.59	23.19	46.00	-22.81	10.10
0.90	37.54	56.00	-18.46	20.63	46.00	-25.37	10.10
3.26	41.75	56.00	-14.25	27.26	46.00	-18.74	10.15
1.13	40.73	56.00	-15.27	20.36	46.00	-25.64	10.10



## **5.8 §15.209, §15.205 & §15.247(d) - Radiated Spurious Emissions & Unwanted Emissions into Restricted Frequency Bands**

1. All possible modes of operation were investigated. Only the 6 worst case emissions measured, using the correct CISPR detectors, are reported. All other emissions were relatively insignificant.
2. A "-ve" margin indicates a PASS as it refers to the margin present below the limit line at the particular frequency.
3. Radiated Emissions Measurement Uncertainty  
All test measurements carried out are traceable to national standards. The uncertainty of the measurement at a confidence level of approximately 95% (in the case where distributions are normal), with a coverage factor of 2, in the range 30MHz – 1GHz & 1GHz above ( 3m & 10m) is +/-6dB.
4. Environmental Conditions
 

Temperature	22°C
Relative Humidity	55%
Atmospheric Pressure	1009mbar
5. Test date : February 18, 2014  
Tested By : Kahn Yang

**Requirement: §15.247(d)** specifies that emissions which fall in the restricted bands, as defined in **§15.205(a)**, must comply with the radiated emission limits specified in **§15.209(a)**.

### **Procedures:**

#### **Radiated Spurious Emissions Measurement**

An additional consideration when performing conducted measurements of restricted band emissions is that unwanted emissions radiating from the EUT cabinet, control circuits, power leads, or intermediate circuit elements will likely go undetected in a conducted measurement configuration. To address this concern, a radiated test shall be performed to ensure that emissions emanating from the EUT cabinet (rather than the antenna port) also comply with the applicable limits.

For these radiated spurious emission measurements the EUT transmit antenna may be replaced with a termination matching the nominal impedance of the antenna. Established procedures for performing radiated measurements shall be used (see C63.10). All detected emissions must comply with the applicable limits.

#### **Measurement Detectors**

**§15.35(a)** specifies that on frequencies less than and below 1000 MHz, the radiated emissions limits assume the use of a CISPR quasi-peak detector function and related measurement bandwidths. **§15.35(b)** specifies that on frequencies above 1000 MHz, the radiated emissions limits assume the use of an average detector and a minimum resolution bandwidth of 1 MHz. In addition, **§15.35(b)** that when average radiated emissions measurements are specified there is also a limit on the peak emissions level which is 20 dB above the applicable maximum permitted average emission limit. These specifications also apply to conducted emissions measurements.

#### **1. CISPR Quasi-Peak Measurement**

The specifications for the measuring instrument using the CISPR quasi-peak detector can be found in Publication 16 of the International Special Committee on Radio Frequency Interference (CISPR) of the International Electrotechnical Commission.

As an alternative to CISPR quasi-peak measurement, compliance can be demonstrated to the applicable emission limits using a peak detector.

#### **2. Peak Power Measurement Procedure**

Utilize the peak power measurement procedure specified in Section 8.1.1 with the following modifications:

Set analyzer center frequency to the frequency associated with the restricted band emission under examination.

Set RBW = 1 MHz.

Note that if the peak measured value complies with the average limit, it is not necessary to perform a separate average measurement. If this option is exercised, it should be so noted in the test report.

#### **3. Average Power Measurement Procedures**

The average restricted band emission levels must be measured with the EUT transmitting continuously ( $\geq 98\%$  duty cycle) at its maximum power control level. Optionally, video triggering/signal gating can be used to ensure that measurements are performed only when the EUT is transmitting at its maximum power control level.

The average power measurement procedures described in Section 8.2 shall be used with the following modifications:

Set analyzer center frequency to the frequency associated with the restricted band emission.



Set span to at least 1 MHz.

Use peak marker function to determine the highest amplitude within the RBW (1 MHz).

**Test Result: Pass**

<b>Test Mode:</b>	<b>Transmitting Mode(Worse Case)</b>
-------------------	--------------------------------------

**(Below 1GHz)**

Peak Detector   
 Quasi Peak Limit 

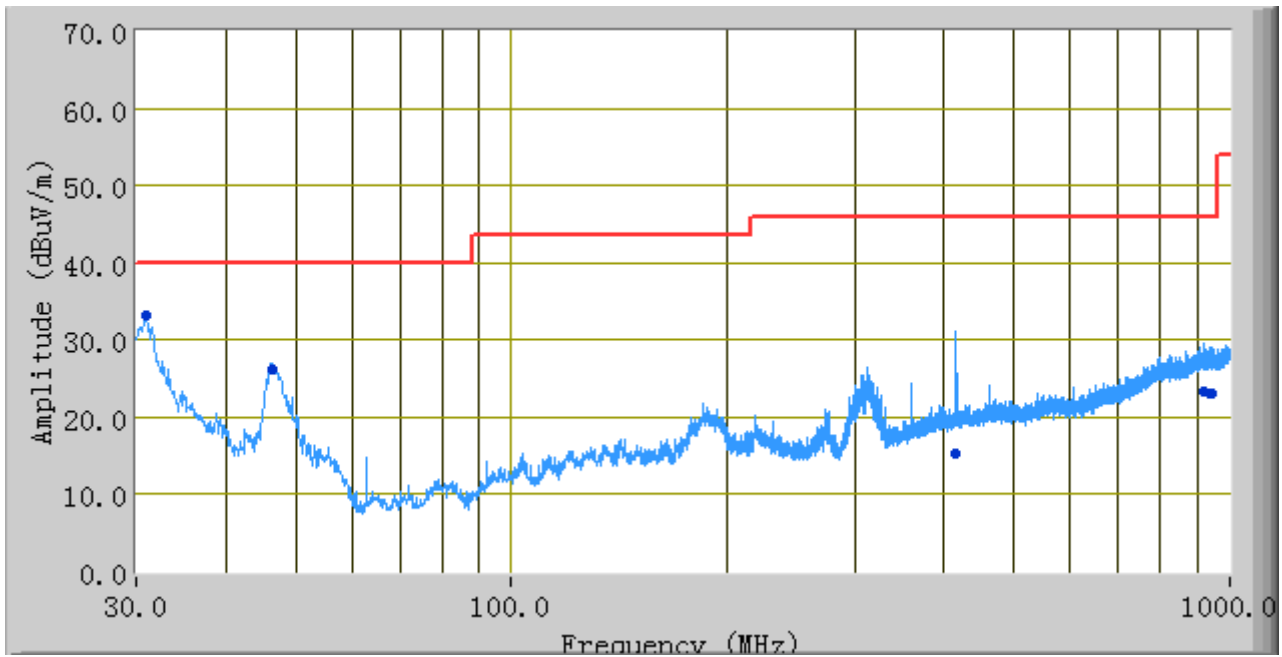

**Test Data**

**Vertical & Horizontal Polarity Plot @3m**

Frequency (MHz)	Quasi Peak (dBuV/m)	Azimuth	Polarity(H/V)	Height (cm)	Factors (dB)	Limit (dBuV)	Margin (dB)
30.85	33.28	307.00	V	115.00	-2.18	40.00	-6.72
46.40	26.16	217.00	V	114.00	-12.22	40.00	-13.84
415.89	15.41	112.00	H	100.00	-2.83	46.00	-30.59
918.96	23.23	116.00	V	284.00	5.07	46.00	-22.77
946.82	23.14	260.00	H	400.00	5.51	46.00	-22.86
940.03	23.06	210.00	H	204.00	5.40	46.00	-22.94

**Above 1 GHz:**

*Test Mode: Transmitting*

**Note: Other modes were verified, only the result of worst case basic rate mode was presented.**

**Mode: 802.11b**  
Low Channel (2412 MHz)

Frequency (MHz)	Substituted level (dBµV/m)	Detector (PK/AV)	Direction (degree)	Height (m)	Polarity (H/V)	Ant. Factor (dB/m)	Cable Loss (dB)	Pre-Amp. Gain (dB)	Cord. Amp. (dBµV/m)	Limit (dBµV/m)	Margin (dB)
4824	37.78	AV	318	1.4	V	33.83	1.03	24	46.58	54	-7.42
4824	38.401	AV	60	1.4	H	33.83	1.03	24	47.2	54	-6.8
4824	42.71	PK	318	1.4	V	33.83	1.03	24	51.51	74	-22.49
4824	42.72	PK	60	1.4	H	33.83	1.03	24	51.52	74	-22.48
1510	35.10	AV	48	1.5	V	25.72	0.64	24	36.18	54	-17.82
1510	34.92	AV	169	1.5	H	25.72	0.64	24	36	54	-18
1510	45.11	PK	48	1.5	V	25.72	0.64	24	46.19	74	-27.81
1510	45.14	PK	169	1.5	H	25.72	0.64	24	46.22	74	-27.78

Middle Channel (2437 MHz)

Frequency (MHz)	Substituted level (dBµV/m)	Detector (PK/AV)	Direction (degree)	Height (m)	Polarity (H/V)	Ant. Factor (dB/m)	Cable Loss (dB)	Pre-Amp. Gain (dB)	Cord. Amp. (dBµV/m)	Limit (dBµV/m)	Margin (dB)
4874	36.97	AV	314	1.4	V	33.83	1.03	24	45.77	54	-8.23
4874	38.41	AV	62	1.4	H	33.83	1.03	24	47.21	54	-6.79
4874	43.02	PK	314	1.4	V	33.83	1.03	24	51.82	74	-22.18
4874	43.98	PK	62	1.4	H	33.83	1.03	24	52.78	74	-21.22
1510	34.93	AV	44	1.5	V	25.72	0.64	24	36.01	54	-17.99
1510	35.02	AV	168	1.5	H	25.72	0.64	24	36.1	54	-17.9
1510	44.38	PK	44	1.5	V	25.72	0.64	24	45.46	74	-28.54
1510	44.65	PK	168	1.5	H	25.72	0.64	24	45.73	74	-28.27

High Channel (2462 MHz)

Frequency (MHz)	Substituted level (dBµV/m)	Detector (PK/AV)	Direction (degree)	Height (m)	Polarity (H/V)	Ant. Factor (dB/m)	Cable Loss (dB)	Pre-Amp. Gain (dB)	Cord. Amp. (dBµV/m)	Limit (dBµV/m)	Margin (dB)
4924	36.66	AV	317	1.4	V	33.83	1.03	24	45.46	54	-8.54
4924	38.39	AV	65	1.4	H	33.83	1.03	24	47.19	54	-6.81
4924	43.27	PK	317	1.4	V	33.83	1.03	24	52.07	74	-21.93
4924	44.08	PK	65	1.4	H	33.83	1.03	24	52.88	74	-21.12
1510	33.58	AV	41	1.5	V	25.72	0.64	24	34.66	54	-19.34
1510	34.97	AV	166	1.5	H	25.72	0.64	24	36.05	54	-17.95
1510	45.00	PK	41	1.5	V	25.72	0.64	24	46.08	74	-27.92
1510	46.01	PK	166	1.5	H	25.72	0.64	24	47.09	74	-26.91

**Annex A. TEST INSTRUMENT & METHOD**

**Annex A.i. TEST INSTRUMENTATION & GENERAL PROCEDURES**

Instrument	Model	Serial #	Calibration Date	Calibration Due Date
<b>AC Line Conducted Emissions</b>				
EMI test receiver	ESCS30	8471241027	05/27/2013	05/26/2014
Line Impedance Stabilization Network	LI-125A	191106	11/14/2013	11/13/2014
Line Impedance Stabilization Network	LI-125A	191107	11/14/2013	11/13/2014
Line Impedance Stabilization Network	LI-125A	191108	11/14/2013	11/13/2014
Line Impedance Stabilization Network	LI-125A	191109	11/14/2013	11/13/2014
LISN	ISN T800	34373	01/11/2014	01/10/2015
Double Ridge Horn Antenna (1 ~18GHz)	AH-118	71283	11/20/2013	11/19/2014
Transient Limiter	LIT-153	531118	09/02/2013	09/01/2014
<b>RF conducted test</b>				
Agilent ESA-E SERIES SPECTRUM ANALYZER	E4407B	MY45108319	09/17/2013	09/16/2014
Power Splitter	1#	1#	09/02/2013	09/01/2014
DC Power Supply	E3640A	MY40004013	09/17/2013	09/16/2014
Wireless Connectivity Test Set	N4010A	GB44440198	03/20/2013	03/19/2014
<b>Radiated Emissions</b>				
EMI test receiver	ESL6	100262	11/23/2013	11/22/2014
Positioning Controller	UC3000	MF780208282	11/19/2013	11/19/2014
OPT 010 AMPLIFIER (0.1-1300MHz)	8447E	2727A02430	09/02/2013	09/01/2014
Microwave Preamplifier (0.5 ~18GHz)	PAM-118	443008	09/02/2013	09/01/2014
Bilog Antenna (30MHz~6GHz)	JB6	A110712	09/23/2013	09/22/2014
Double Ridge Horn Antenna (1 ~18GHz)	AH-118	71283	11/20/2013	11/19/2014
Universal Radio Communication Tester	CMU200	121393	09/17/2013	09/16/2014

## Annex A.ii. CONDUCTED EMISSIONS TEST DESCRIPTION

### Test Set-up

1. The EUT and supporting equipment were set up in accordance with the requirements of the standard on top of a 1.5m x 1m x 0.8m high, non-metallic table, as shown in Annex B.
2. The power supply for the EUT was fed through a 50Ω/50μH EUT LISN, connected to filtered mains.
3. The RF OUT of the EUT LISN was connected to the EMI test receiver via a low-loss coaxial cable.
4. All other supporting equipments were powered separately from another main supply.

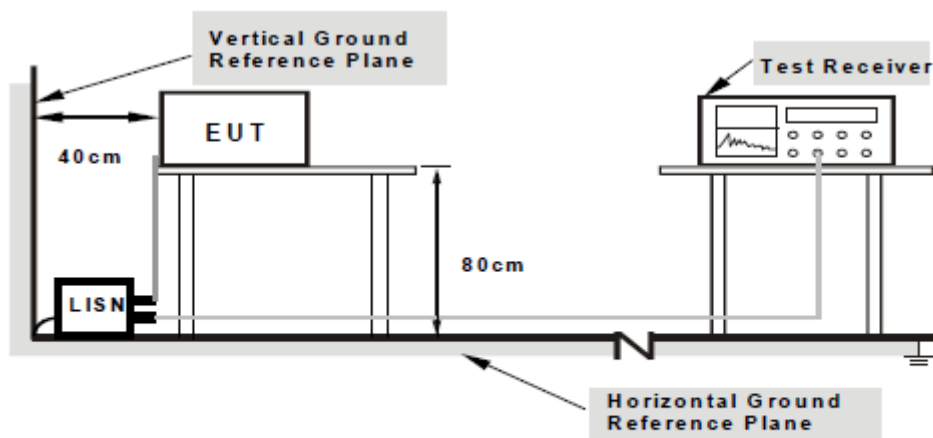

**Note: 1.** Support units were connected to second LISN.  
**2.** Both of LISNs (AMN) are 80cm from EUT and at least 80cm from other units and other metal planes support units.

For the actual test configuration, please refer to the related item – Photographs of the Test Configuration1.

### Test Method

1. The EUT was switched on and allowed to warm up to its normal operating condition.
2. A scan was made on the NEUTRAL line (for AC mains) or Earth line (for DC power) over the required frequency range using an EMI test receiver.
3. High peaks, relative to the limit line, were then selected.
4. The EMI test receiver was then tuned to the selected frequencies and the necessary measurements made with a receiver bandwidth setting of 10 kHz. For FCC tests, only Quasi-peak measurements were made; while for CISPR/EN tests, both Quasi-peak and Average measurements were made.
5. Steps 2 to 4 were then repeated for the LIVE line (for AC mains) or DC line (for DC power).

### Description of Conducted Emission Program

This EMC Measurement software run LabView automation software and offers a common user interface for electromagnetic interference (EMI) measurements. This software is a modern and powerful tool for controlling and monitoring EMI test receivers and EMC test systems. It guarantees reliable collection, evaluation, and documentation of measurement results. Basically, this program will run a pre-scan measurement before it proceeds with the final measurement. The pre-scan routine will run the common scan range from 150 kHz to 30 MHz; the program will first start a peak and average scan on selectable measurement time and step size. After the program complete the pre-scan, this program will perform the Quasi Peak and Average measurement, based on the pre-scan peak data reduction result.

### Sample Calculation Example

At 20 MHz

limit =  $250 \mu\text{V} = 47.96 \text{ dB}\mu\text{V}$

Transducer factor of LISN, pulse limiter & cable loss at 20 MHz = 11.20 dB

Q-P reading obtained directly from EMI Receiver = 40.00 dB $\mu\text{V}$   
(Calibrated for system losses)

Therefore, Q-P margin =  $47.96 - 40.00 = 7.96$  i.e. **7.96 dB below limit**

**Annex A. iii RADIATED EMISSIONS TEST DESCRIPTION**

**EUT Characterisation**

EUT characterisation, over the frequency range from 30MHz to 10<sup>th</sup> Harmonic , was done in order to minimise radiated emissions testing time while still maintaining high confidence in the test results.

The EUT was placed in the chamber, at a height of about 0.8m on a turntable. Its radiated emissions frequency profile was observed, using a spectrum analyzer /receiver with the appropriate broadband antenna placed 3m away from the EUT. Radiated emissions from the EUT were maximised by rotating the turntable manually, changing the antenna polarisation and manipulating the EUT cables while observing the frequency profile on the spectrum analyzer / receiver. Frequency points at which maximum emissions occurred, clock frequencies and operating frequencies were then noted for the formal radiated emissions test at the Open Area Test Site (OATS).

**Test Set-up**

1. The EUT and supporting equipment were set up in accordance with the requirements of the standard on top of a 1.5m X 1.0m X 0.8m high, non-metallic table.
2. The filtered power supply for the EUT and supporting equipment were tapped from the appropriate power sockets located on the turntable.
3. The relevant broadband antenna was set at the required test distance away from the EUT and supporting equipment boundary.

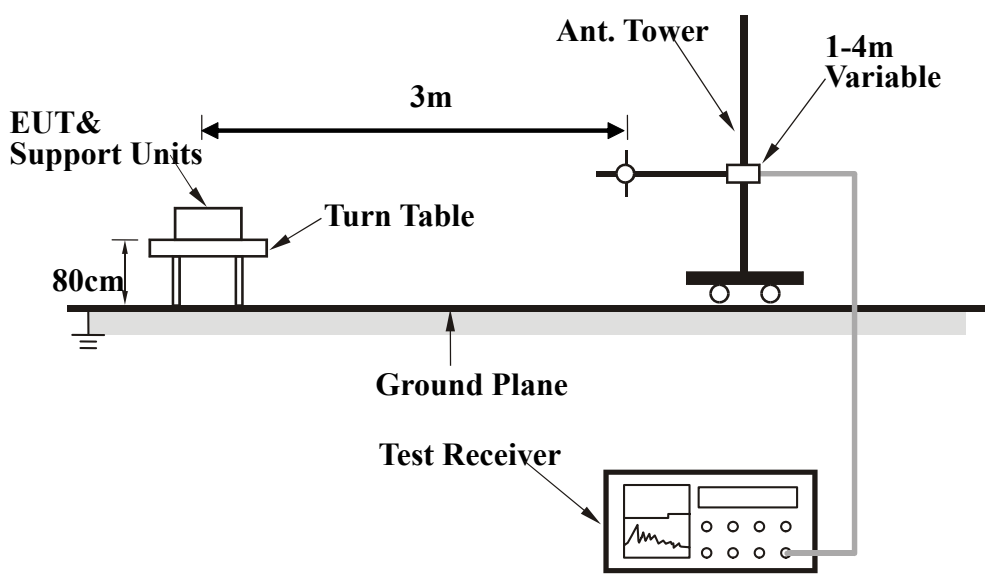

**Test Method**

The following procedure was performed to determine the maximum emission axis of EUT:

1. With the receiving antenna is H polarization, rotate the EUT in turns with three orthogonal axes to determine the axis of maximum emission.
2. With the receiving antenna is V polarization, rotate the EUT in turns with three orthogonal axes to determine the axis of maximum emission.
3. Compare the results derived from above two steps. So, the axis of maximum emission from EUT was determined and the configuration was used to perform the final measurement.

**Final Radiated Emission Measurement**

1. Setup the configuration according to figure 1. Turn on EUT and make sure that it is in normal function.
2. For emission frequencies measured below 1 GHz, a pre-scan is performed in a shielded chamber to determine the accurate frequencies of higher emissions will be checked on a open test site. As the same purpose, for emission frequencies measured above 1 GHz, a pre-scan also be performed with a 1 meter measuring distance before final test.
3. For emission frequencies measured below and above 1 GHz, set the spectrum analyzer on a 100 kHz and 1 MHz resolution bandwidth respectively for each frequency measured in step 2.
4. The search antenna is to be raised and lowered over a range from 1 to 4 meters in horizontally polarized orientation. Position the highness when the highest value is indicated on spectrum analyzer, then change the orientation of EUT on test table over a range from 0 ° to 360 ° with a speed as slow as possible, and keep the azimuth that highest emission is indicated on the spectrum analyzer. Vary the antenna position again and record the highest value as a final reading.
5. Repeat step 4 until all frequencies need to be measured was complete.
6. Repeat step 5 with search antenna in vertical polarized orientations.

During the radiated emission test, the Spectrum Analyzer was set with the following configurations:

Frequency Band (MHz)	Function	Resolution bandwidth	Video Bandwidth
30 to 1000	Peak	100 kHz	100 kHz
Above 1000	Peak	1 MHz	1 MHz
	Average	1 MHz	10 Hz

**Sample Calculation Example**

The field strength is calculated by adding the Antenna Factor and Cable Factor, and subtracting the Amplifier Gain (if any) from the measured reading. For the limit is employed average value, therefore the peak value can be transferred to average value by subtracting the duty factor. The basic equation with a sample calculation is as follows:

$$\text{Peak} = \text{Reading} + \text{Corrected Factor}$$

where

$$\text{Corr. Factor} = \text{Antenna Factor} + \text{Cable Factor} - \text{Amplifier Gain (if any)}$$

And the average value is

$$\text{Average} = \text{Peak Value} + \text{Duty Factor or}$$

$$\text{Set RBW} = 1\text{MHz, VBW} = 10\text{Hz.}$$

Note :

If the measured frequencies are fall in the restricted frequency band, the limit employed must be quasi peak value when frequencies are below or equal to 1 GHz. And the measuring instrument is set to quasi peak detector function.



**Annex B. EUT AND TEST SETUP PHOTOGRAPHS**

**Annex B.i. Photograph 1: EUT External Photo**



Whole Package - Top View

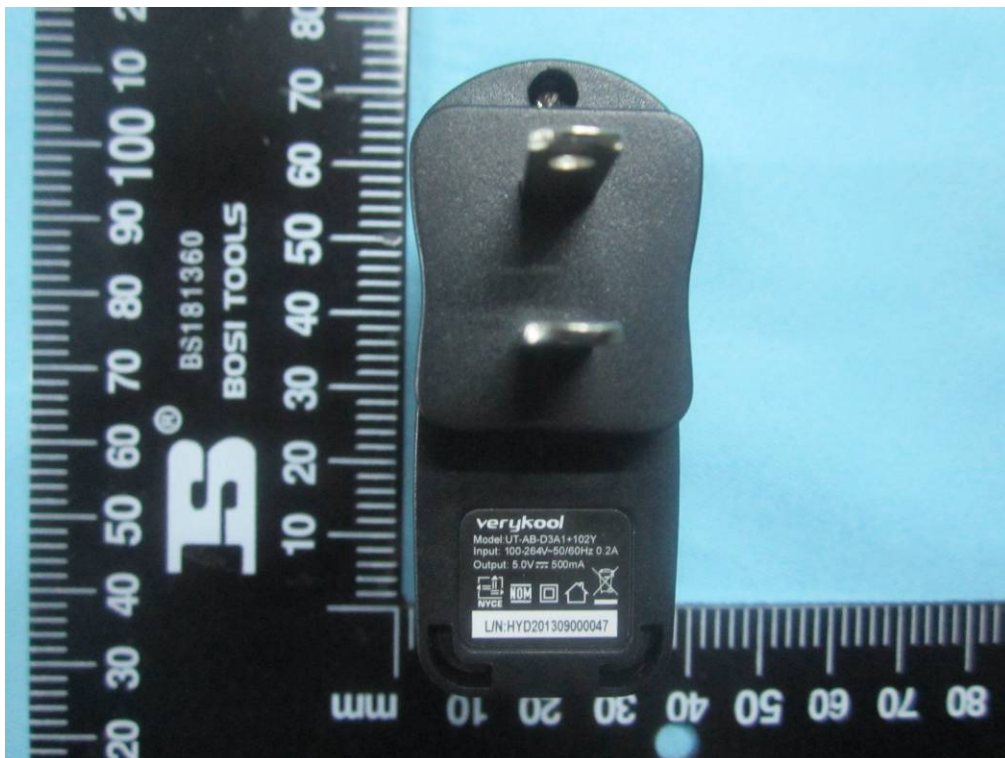

Adapter – Top View



EUT - Front View



EUT - Rear View



**SIEMIC, INC.**

Accessing global markets

Title: RF Test Report for Mobile Phone  
Main Model: s352  
Serial Model: N/A  
To: FCC Part 15.247: 2013, ANSI C63.4: 2009

Report No.: 14070005-FCC-R4  
Issue Date: February 25, 2014  
Page: 59 of 74  
www.siemic.com



EUT - Top View



EUT - Bottom View



**SIEMIC, INC.**

Accessing global markets

Title: RF Test Report for Mobile Phone  
Main Model: s352  
Serial Model: N/A  
To: FCC Part 15.247: 2013, ANSI C63.4: 2009

Report No.: 14070005-FCC-R4  
Issue Date: February 25, 2014  
Page: 60 of 74  
www.siemic.com

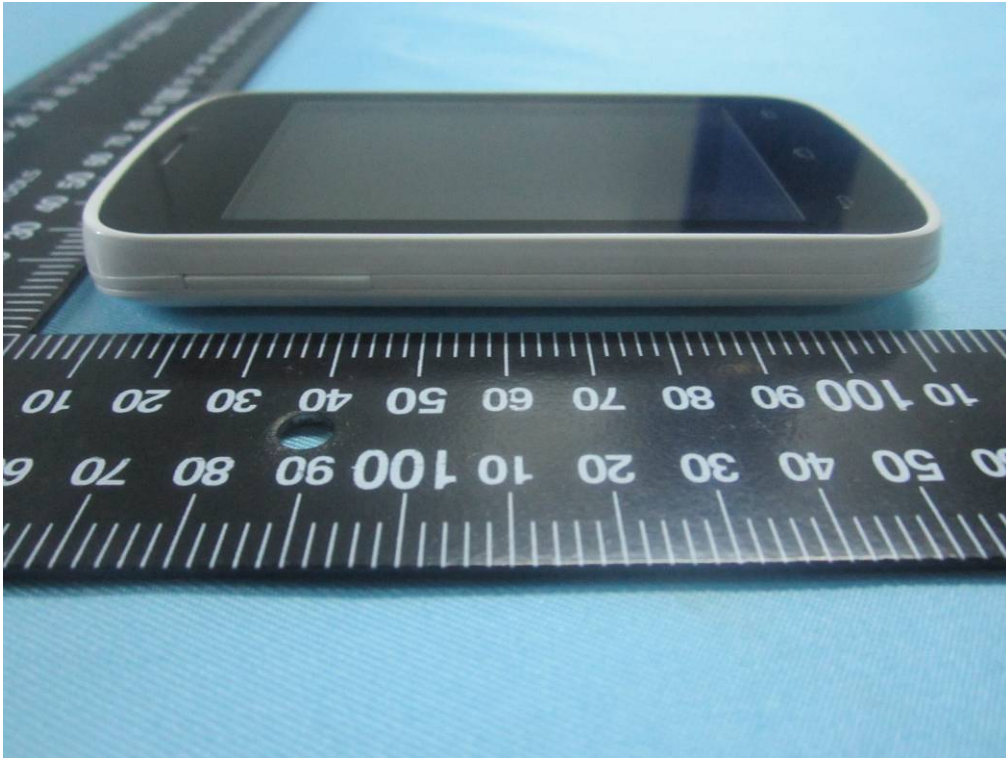

EUT - Left View



EUT - Right View

**Annex B.ii. Photograph 2: EUT Internal Photo**



Cover Off - Top View

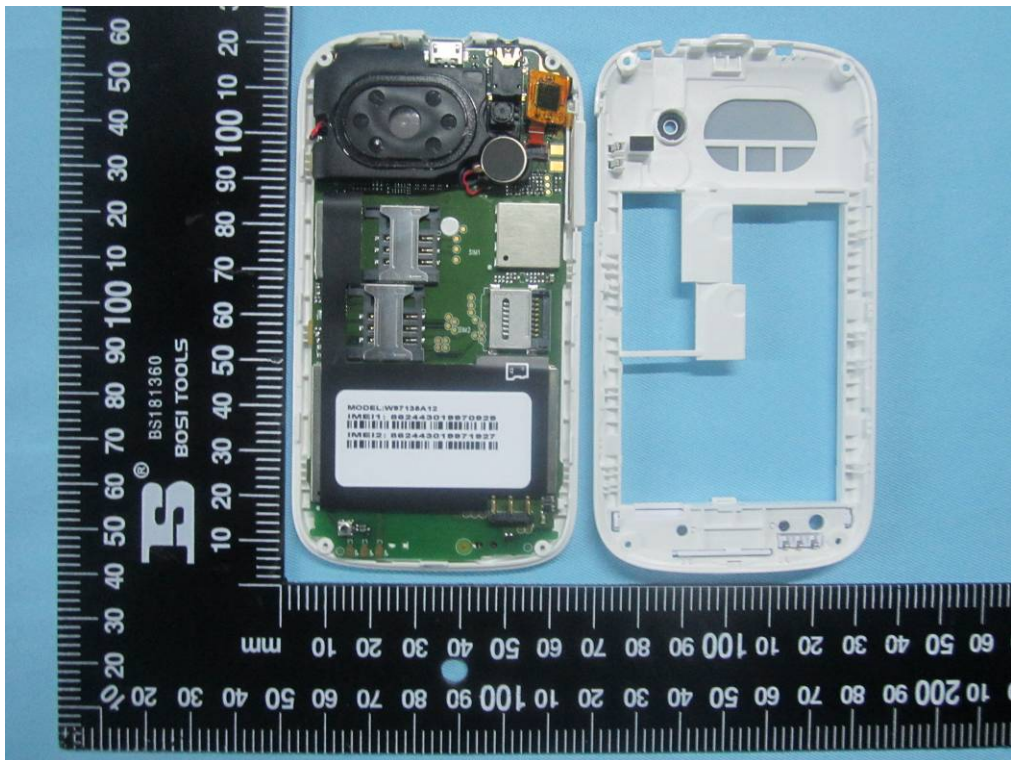

Cover Off - Rear Housing View

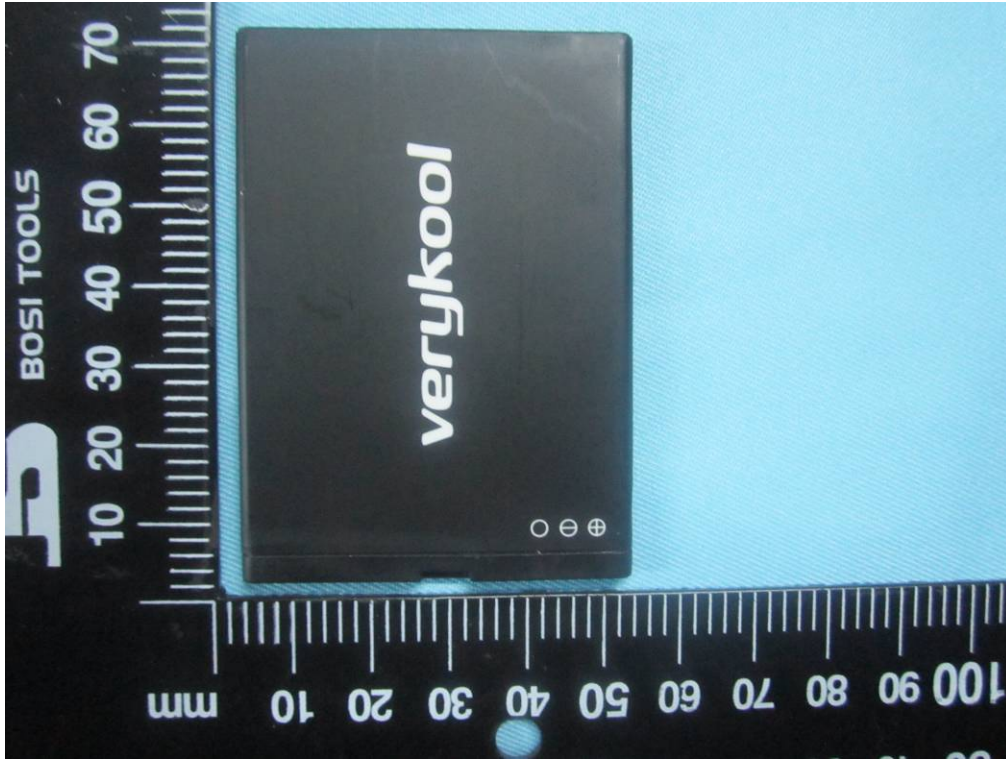

Battery - Top View



Battery - Bottom View

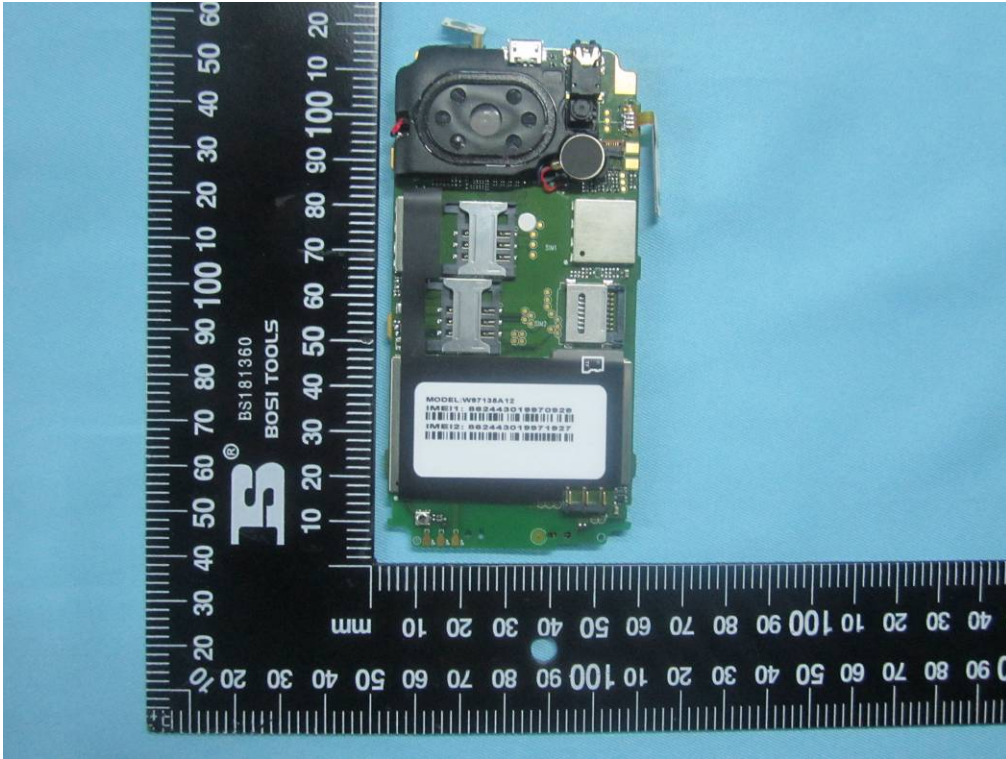

Mainboard With Shielding - Front View

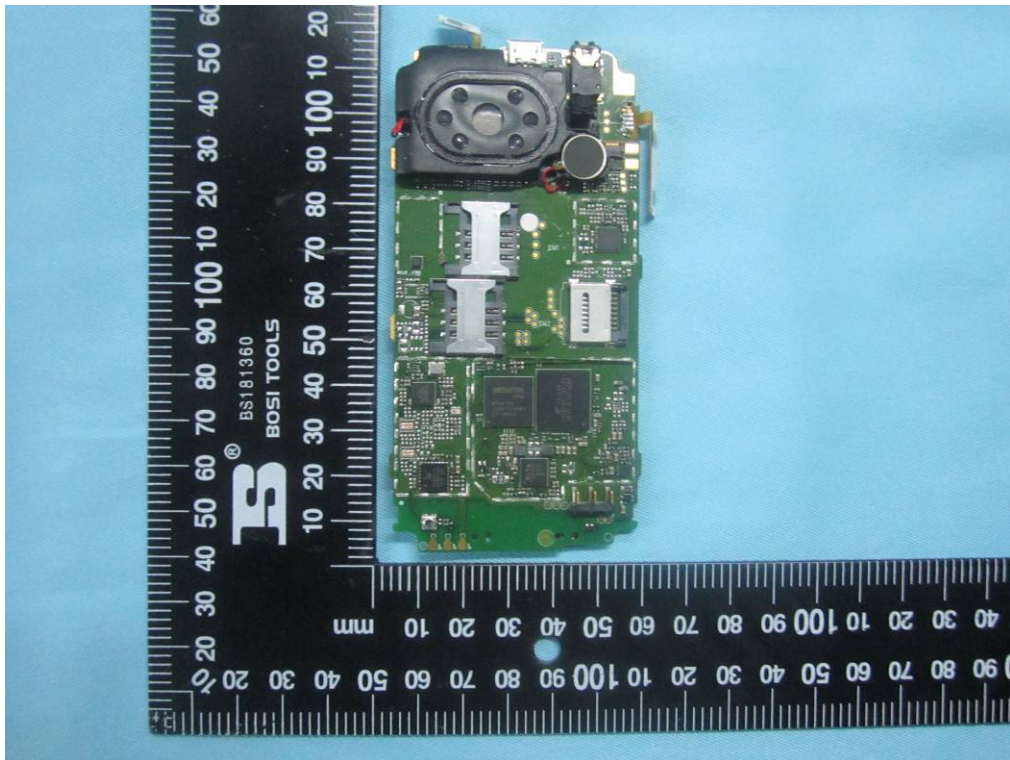

Mainboard Without Shielding - Front View

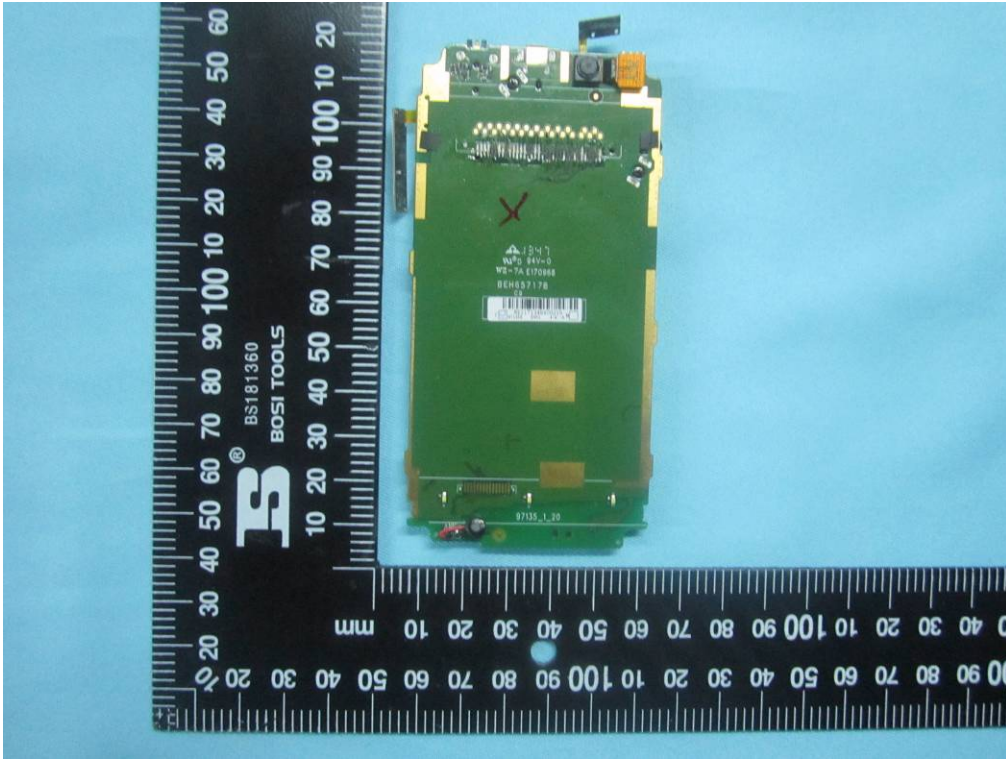

Mainboard – Rear View

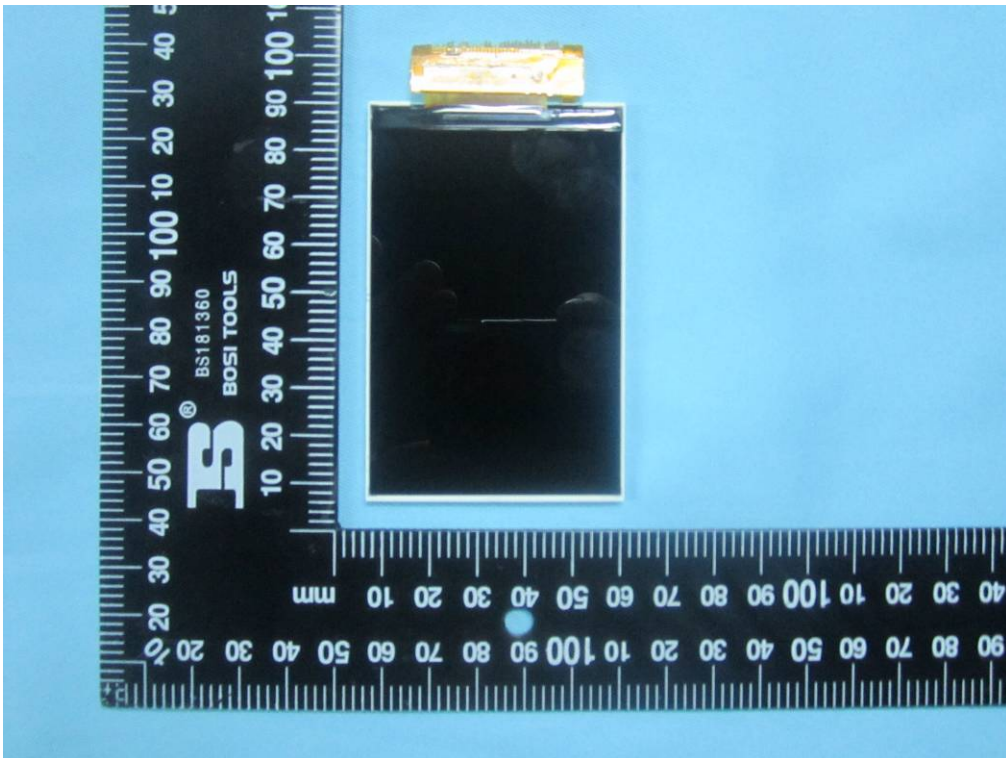

LCD – Top View



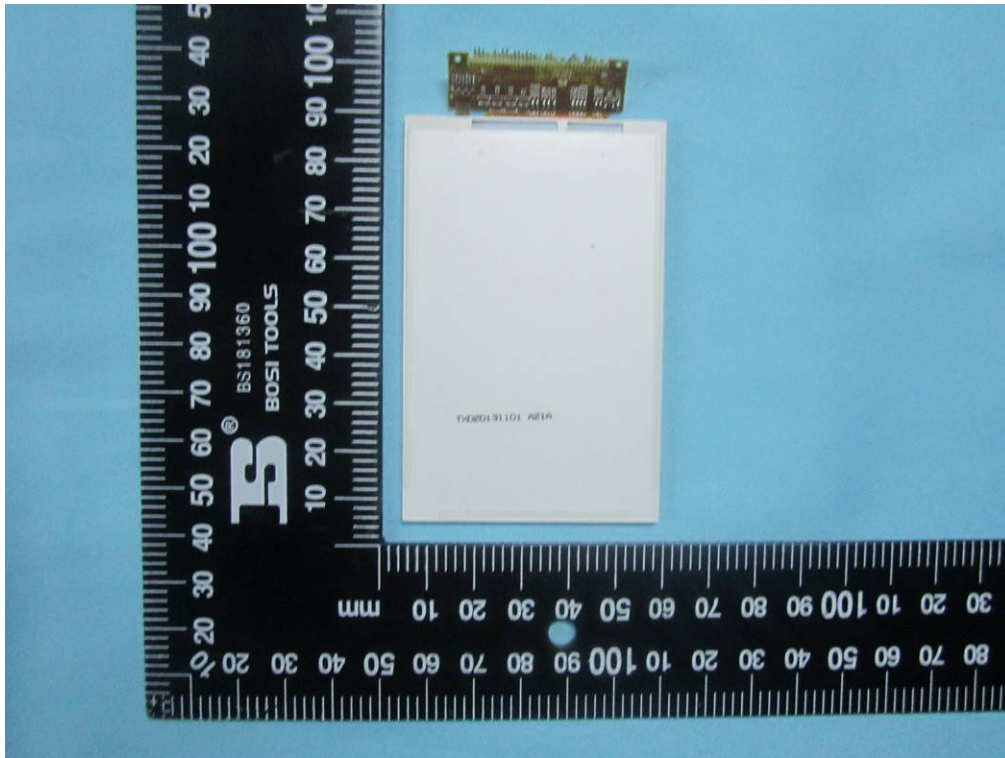

LCD – Bottom View

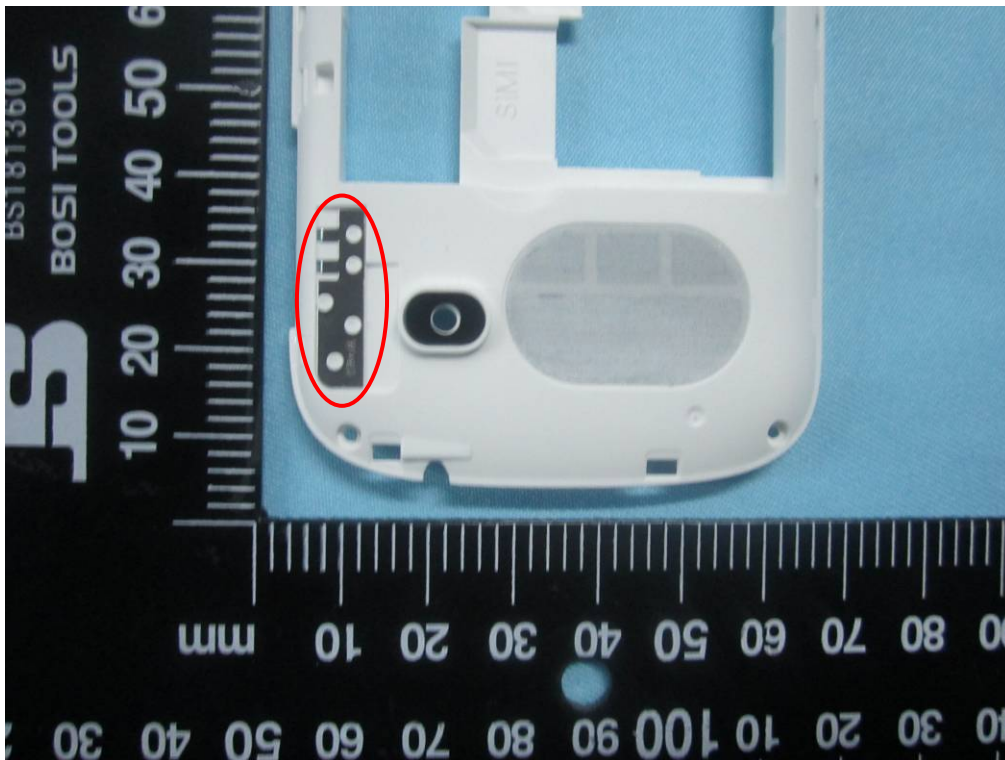

Bluetooth / BLE / WIFI Antenna View

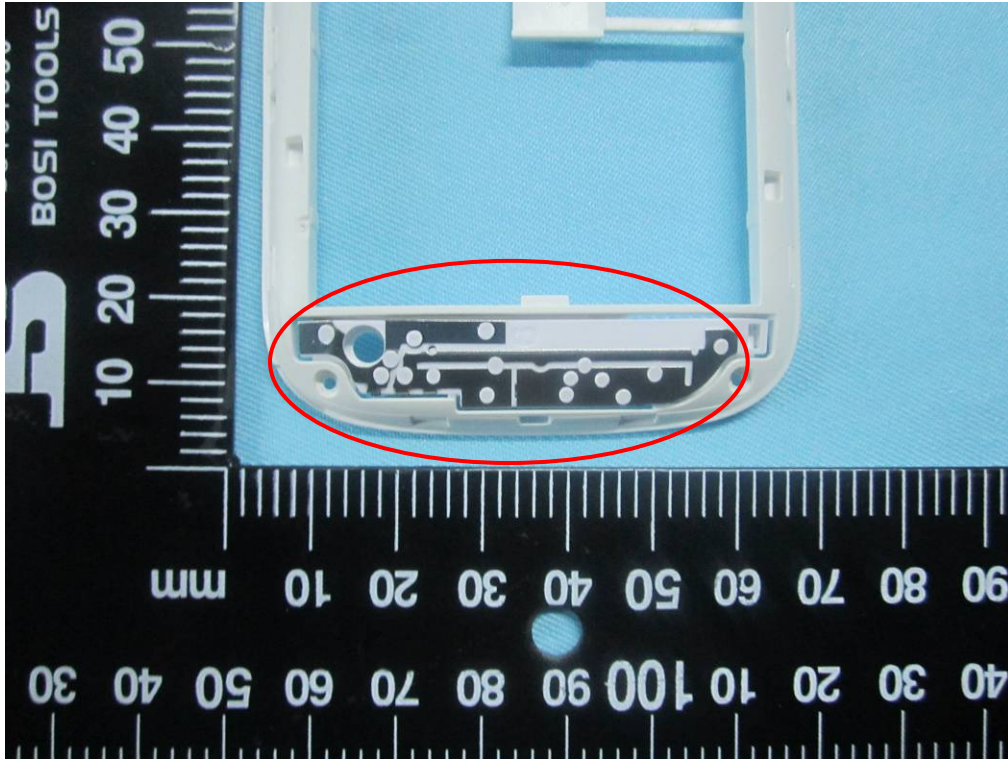

GSM / PCS Antenna View

**Annex B.iii. Photograph 3: Test Setup Photo**



Conducted Emissions Test Setup Front View



Conducted Emissions Test Setup Side View

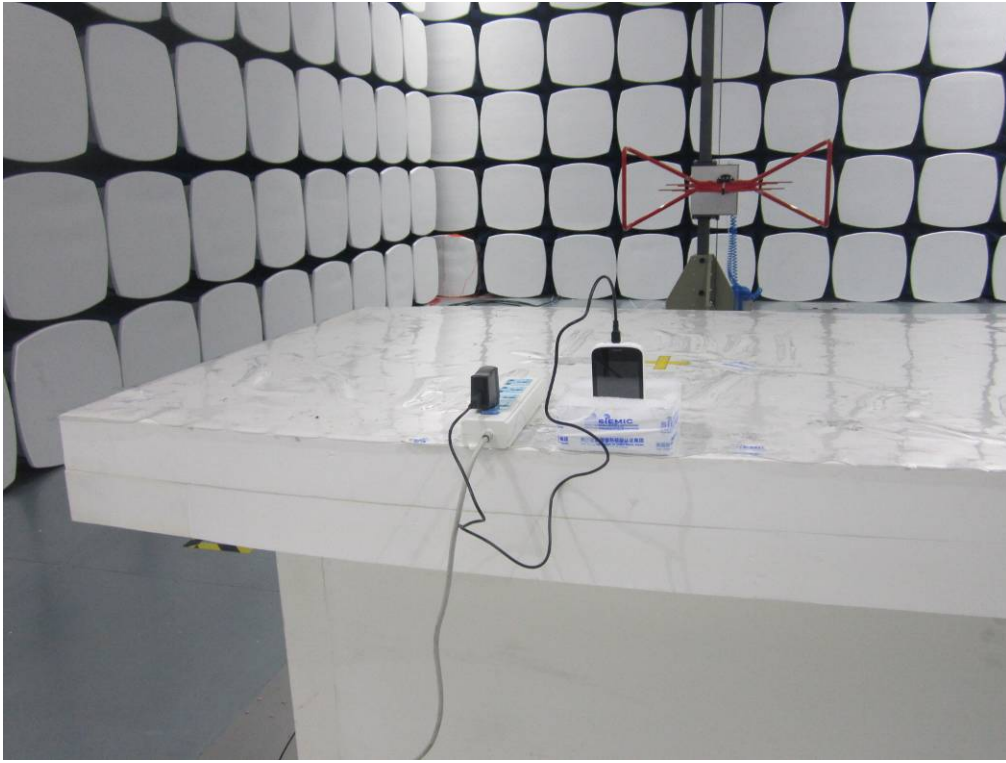

Radiated Spurious Emissions Test Setup Below 1GHz - Front View

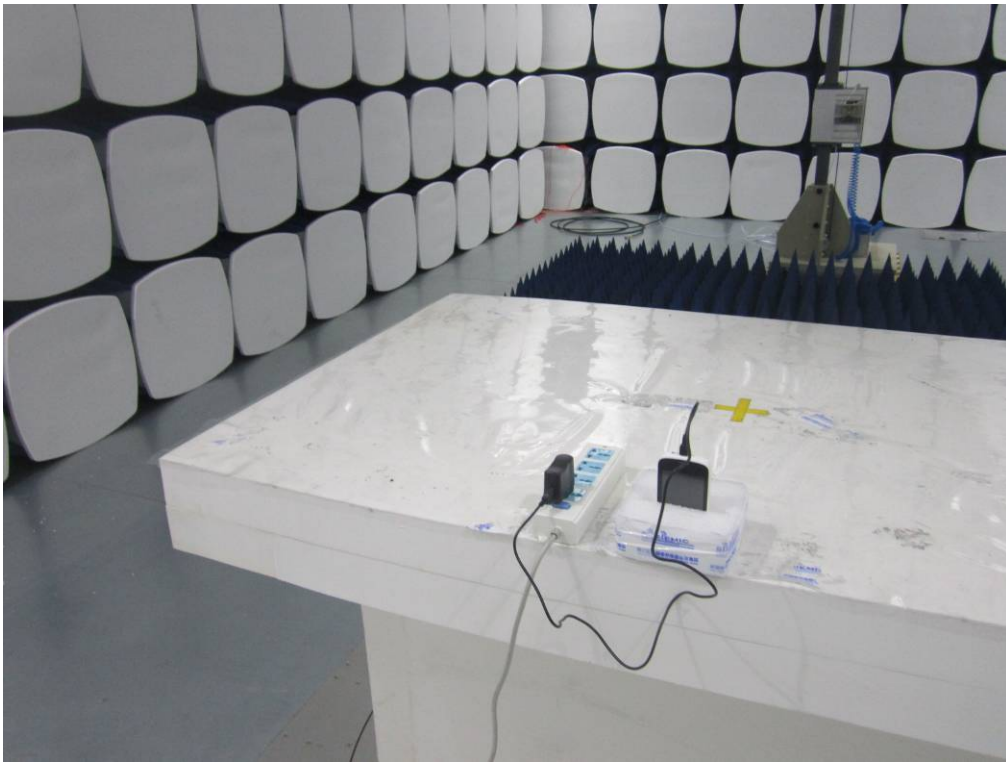

Radiated Spurious Emissions Test Setup Above 1GHz - Front View

**Annex C. TEST SETUP AND SUPPORTING EQUIPMENT**

**EUT TEST CONDITIONS**

**Annex C. i. SUPPORTING EQUIPMENT DESCRIPTION**

The following is a description of supporting equipment and details of cables used with the EUT.

Manufacturer	Equipment Description (Including Brand Name)	Model	Calibration Date	Calibration Due Date
N/A	N/A	N/A	N/A	N/A

**Block Configuration Diagram for AC Line Conducted Emissions**

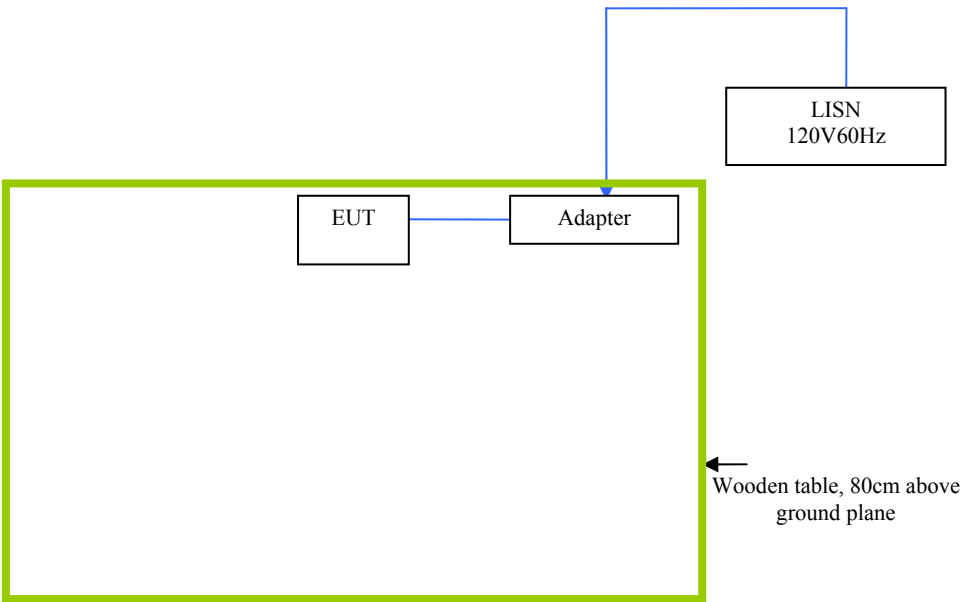

**Block Configuration Diagram for Radiated Emissions**

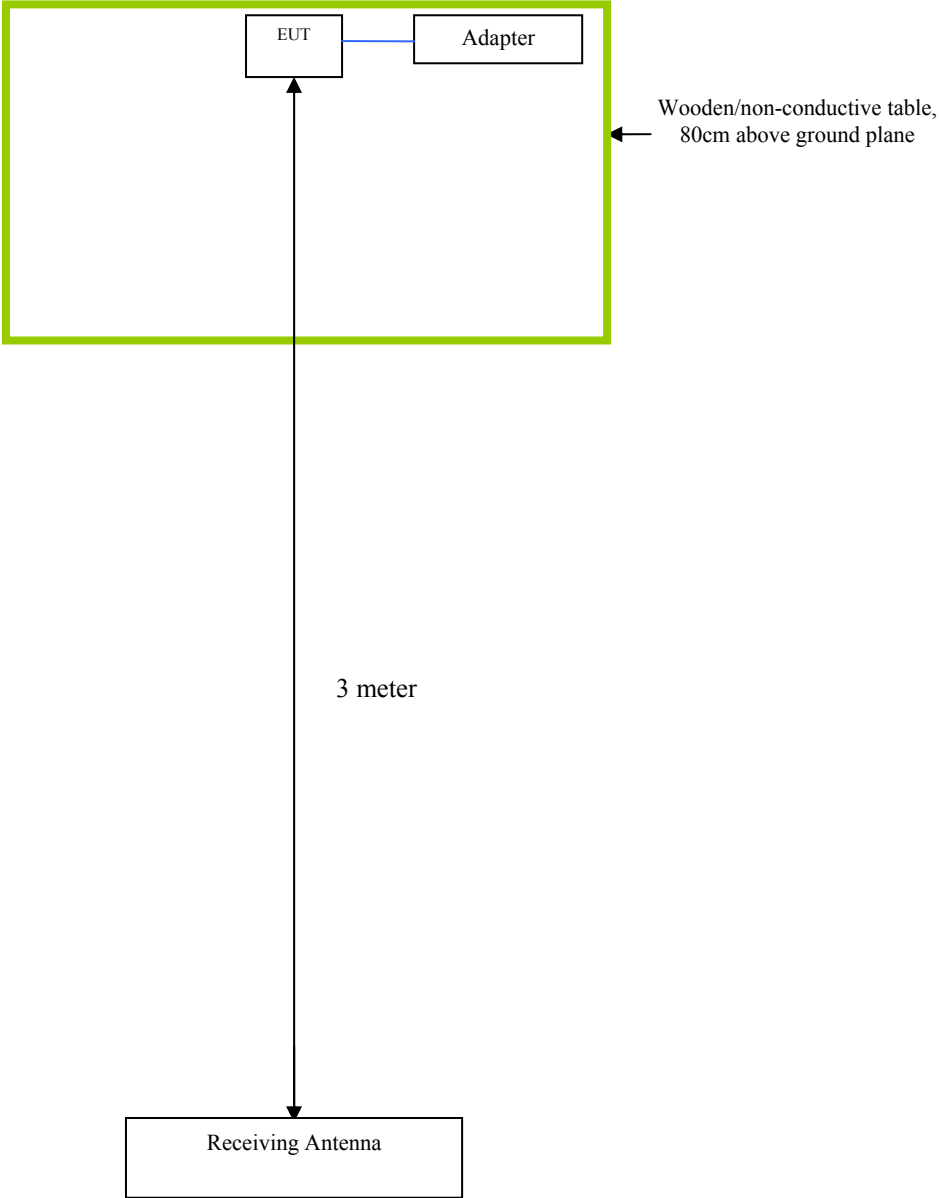

**Annex C.ii. EUT OPERATING CONDITIONS**

The following is the description of how the EUT is exercised during testing.

Test	Description Of Operation
Emissions Testing	The EUT was continuously transmitting to stimulate the worst case.





**SIEMIC, INC.**

Accessing global markets

Title: RF Test Report for Mobile Phone  
Main Model: s352  
Serial Model: N/A  
To: FCC Part 15.247: 2013, ANSI C63.4: 2009

Report No.: 14070005-FCC-R4  
Issue Date: February 25, 2014  
Page: 73 of 74  
[www.siemic.com](http://www.siemic.com)

## **Annex D. USER MANUAL / BLOCK DIAGRAM / SCHEMATICS / PART LIST**

**Please see attachment**

**Annex E. DECLARATION OF SIMILARITY**



Verykool USA INC.  
3636 Nobel Drive, Suite 325, San Diego, CA 92122  
Tel: 001 858 373 1635  
Fax: 001 858 373 1505  
Date: 2013-08-21

**Declaration of Similarity**

To:  
SIEMIC (Shenzhen-China) Laboratories  
Zone A, Floor 1, Building 2, Wan Ye Long Technology Park, South Side of  
Zhoushi Road,  
Shiyan Street, Bao'an District, Shenzhen 518108, Guangdong, P.R.C.  
Tel: +(86) 0755-26014629, 26014953, 27629948, 27628616-808

We, Verykool USA INC. hereby declares that our product, Mobile Phone, Model: s353 and s352, these two models are electrically and mechanically identical, share the same PCB Layout and components. And the difference between them is that s352 has no 3G frequencies (removed related hardware of WCDMA, kept the other parts unchanged) . Model: s353 was tested by SIEMIC, project No.is 13070501.

Sincerely,

Signature:   
SunnyChoi  
Product Management Director