

SAR EVALUATION REPORT

For

Verykool USA Inc.

4350 Executive Dr., #100, San Diego, CA 92121, USA

FCC ID: WA6I725

Report Type: Original Report	Product Type: GSM/GPRS Quad-band Mobile Phone
Test Engineer: Cabin Hu	<i>Cabin Hu</i>
Report Number: RSZ110522001-20	
Report Date: 2011-07-30	
Reviewed By: William Chen EMC Engineer	<i>William Chen</i>
Prepared By: Bay Area Compliance Laboratories Corp. (Shenzhen) 6/F, the 3rd Phase of WanLi Industrial Building, ShiHua Road, FuTian Free Trade Zone Shenzhen, Guangdong, China Tel: +86-755-33320018 Fax: +86-755-33320008	

Note: This test report is prepared for the customer shown above and for the device described herein. It may not be duplicated or used in part without prior written consent from Bay Area Compliance Laboratories Corp. This report **must not** be used by the customer to claim product certification, approval, or endorsement by NVLAP*, NIST, or any agency of the Federal Government.

* This report contain data that are not covered by the NVLAP accreditation and are marked with an asterisk "★" (Rev.2)

Attestation of Test Results		
EUT Information	Company Name	Verykool USA Inc
	EUT Description	GSM/GPRS Quad-band Mobile Phone
	Model Number	i725
	Date of Test	2011.07.28—2011.07.30
Band	Max. SAR Level(s) Measured	Limit (W/Kg)
Cellular	0.541 W/kg, 1g Head Tissue 0.823 W/kg, 1g Body Tissue	1.6
PCS	0.531 W/kg, 1g Head Tissue 0.510 W/kg, 1g Body Tissue	
Applicable Standards	ANSI/IEEE C95.1 : 1999 IEEE Standard for Safety Levels with Respect to Human Exposure to Radio Frequency Electromagnetic Fields,3 kHz to 300 GHz.	
	ANSI/IEEE C95.3 : 2002 IEEE Recommended Practice for Measurements and Computations of Radio Frequency Electromagnetic Fields With Respect to Human Exposure to SuchFields,100 kHz-300 GHz.	
	OET BULLETIN 65 SUPPLEMENT C Evaluating Compliance with FCC Guidelines for Human Exposure To Radiofrequency Electromagnetic Fields.	
	IEEE 1528: 2003 IEEE Recommended Practice for Determining the Peak Spatial-Average Specific Absorption Rate (SAR) in the Human Head from Wireless Communications Devices: Measurement Techniques.	
<p>Note: This wireless device has been shown to be capable of compliance for localized specific absorption rate (SAR) for General Population/Uncontrolled Exposure limits specified in ANSI/IEEE Standards and has been tested in accordance with the measurement procedures specified in FCC OET 65 Supplement C and IEEE 1528-2003.</p> <p style="text-align: center;">The results and statements contained in this report pertain only to the device(s) evaluated.</p>		

TABLE OF CONTENTS

DOCUMENT REVISION HISTORY5

EUT DESCRIPTION6

 TECHNICAL SPECIFICATIONS6

REFERENCE, STANDARDS AND GUIDELINES7

 SAR LIMITS8

FACILITIES AND ACCREDITATION9

DESCRIPTION OF TEST SYSTEM10

EQUIPMENT LIST AND CALIBRATION17

 EQUIPMENTS LIST & CALIBRATION INFO17

SAR MEASUREMENT SYSTEM VERIFICATION18

 LIQUID VERIFICATION18

 SYSTEM ACCURACY VERIFICATION21

 SAR SYSTEM VALIDATION DATA22

EUT TEST STRATEGY AND METHODOLOGY30

 TEST POSITIONS FOR DEVICE OPERATING NEXT TO A PERSON’S EAR30

 CHEEK/TOUCH POSITION31

 EAR/TILT POSITION31

 TEST POSITIONS FOR BODY-WORN AND OTHER CONFIGURATIONS32

 SAR EVALUATION PROCEDURE33

OUTPUT POWER VERIFICATION34

 TEST BLOCK DIAGRAM AND PROCEDURE34

 TEST RESULTS34

SAR SIMULTANEOUS TRANSMISSION EVALUATION36

 SIMULTANEOUS TRANSMISSION CONSIDERATION36

SAR MEASUREMENT RESULTS37

 SAR TEST DATA37

APPENDIX A – MEASUREMENT UNCERTAINTY81

APPENDIX B – PROBE CALIBRATION CERTIFICATES82

APPENDIX C – DIPOLE CALIBRATION CERTIFICATES122

APPENDIX D – EUT TEST POSITION PHOTOS142

 LIQUID DEPTH ≥ 15 CM142

 BODY-WORN BACK SETUP PHOTO (KEYPAD CLOSED)142

 LEFT HEAD TOUCH SETUP PHOTO (KEYPAD CLOSED)143

 LEFT HEAD TILT SETUP PHOTO (KEYPAD CLOSED)143

 RIGHT HEAD TOUCH SETUP PHOTO (KEYPAD CLOSED)144

 RIGHT HEAD TILT SETUP PHOTO (KEYPAD CLOSED)144

 BODY-WORN BACK SETUP PHOTO (KEYPAD OPENED)145

 LEFT HEAD TOUCH SETUP PHOTO (KEYPAD OPENED)145

 LEFT HEAD TILT SETUP PHOTO (KEYPAD OPENED)146

 RIGHT HEAD TOUCH SETUP PHOTO (KEYPAD OPENED)146

 RIGHT HEAD TILT SETUP PHOTO (KEYPAD OPENED)147

APPENDIX E – EUT PHOTOS148

 EUT – FRONT SIDE VIEW (CLOSE KEYPAD)148

 EUT – BACK SIDE VIEW (CLOSE KEYPAD)148

EUT – FRONT SIDE VIEW (OPEN KEYPAD).....	149
EUT – FRONT SIDE VIEW (OPEN KEYPAD).....	149
EUT – UNCOVERED VIEW	150
EUT- RIGHT SIDE VIEW	150
EUT- LEFT SIDE VIEW.....	151
APPENDIX F - INFORMATIVE REFERENCES.....	152

DOCUMENT REVISION HISTORY

Revision Number	Report Number	Description of Revision	Date of Revision
0	RSZ110522001-20	Original Report	2011-07-30

EUT DESCRIPTION

This Bay Area Compliance Laboratories Corp. test report has been prepared on behalf of Verykool USA Inc, and their product, Model: i725, FCC ID: WA6I725 or the EUT (Equipment Under Test) as referred to in the rest of this report.

Technical Specifications

Product Type	Portable
Exposure Category:	Population/Uncontrolled
Antenna Type(s):	Internal Antenna
Body-Worn Accessories:	Headset
Head Accessories:	None
GPRS Class:	12
Capability Class	B
DTM Multi-Slot Class	EUT does not support DTM
Mode of Operation	GSM Voice and GPRS data Bluetooth
Frequency Band:	Cellular Band: 824-849 MHz (TX); 869-894 MHz (RX) PCS Band: 1850-1910 MHz(TX);1930-1990 MHz (RX) Bluetooth: 2400-2483.5 MHz (Tx/Rx)
Maximum Conducted Power Tested:	GSM: 32.47 dBm (Cellular Band) GSM: 30.58 dBm (PCS Band) Bluetooth: 0.53 dBm
Dimensions (L*W*H):	112 mm (L)× 58 mm (W)× 12 mm (H)
Weight:	121 g
Power Source:	3.7VDC/900 mAh Rechargeable Battery
Normal Operation:	Head and Body-worn

REFERENCE, STANDARDS AND GUIDELINES

FCC:

The Report and Order requires routine SAR evaluation prior to equipment authorization of portable transmitter devices, including portable telephones. For consumer products, the applicable limit is 1.6 mW/g as recommended by the ANSI/IEEE standard C95.1-1992 [6] for an uncontrolled environment (Paragraph 65). According to the Supplement C of OET Bulletin 65 "Evaluating Compliance with FCC Guide-lines for Human Exposure to Radio frequency Electromagnetic Fields", released on Jun 29, 2001 by the FCC, the device should be evaluated at maximum output power (radiated from the antenna) under "worst-case" conditions for normal or intended use, incorporating normal antenna operating positions, device peak performance frequencies and positions for maximum RF energy coupling.

This report describes the methodology and results of experiments performed on wireless data terminal. The objective was to determine if there is RF radiation and if radiation is found, what is the extent of radiation with respect to safety limits. SAR (Specific Absorption Rate) is the measure of RF exposure determined by the amount of RF energy absorbed by human body (or its parts) – to determine how the RF energy couples to the body or head which is a primary health concern for body worn devices. The limit below which the exposure to RF is considered safe by regulatory bodies in North America is 1.6 mW/g average over 1 gram of tissue mass.

CE:

The order requires routine SAR evaluation prior to equipment authorization of portable transmitter devices, including portable telephones. For consumer products, the applicable limit is 2 mW/g as recommended by EN62209-1 for an uncontrolled environment. According to the Standard, the device should be evaluated at maximum output power (radiated from the antenna) under "worst-case" conditions for normal or intended use, incorporating normal antenna operating positions, device peak performance frequencies and positions for maximum RF energy coupling.

This report describes the methodology and results of experiments performed on wireless data terminal. The objective was to determine if there is RF radiation and if radiation is found, what is the extent of radiation with respect to safety limits. SAR (Specific Absorption Rate) is the measure of RF exposure determined by the amount of RF energy absorbed by human body (or its parts) – to determine how the RF energy couples to the body or head which is a primary health concern for body worn devices. The limit below which the exposure to RF is considered safe by regulatory bodies in Europe is 2 mW/g average over 10 gram of tissue mass.

The test configurations were laid out on a specially designed test fixture to ensure the reproducibility of measurements. Each configuration was scanned for SAR. Analysis of each scan was carried out to characterize the above effects in the device.

SAR Limits

FCC Limit (1g Tissue)

EXPOSURE LIMITS	SAR (W/kg)	
	(General Population / Uncontrolled Exposure Environment)	(Occupational / Controlled Exposure Environment)
Spatial Average (averaged over the whole body)	0.08	0.4
Spatial Peak (averaged over any 1 g of tissue)	1.60	8.0
Spatial Peak (hands/wrists/feet/ankles averaged over 10 g)	4.0	20.0

CE Limit (10g Tissue)

EXPOSURE LIMITS	SAR (W/kg)	
	(General Population / Uncontrolled Exposure Environment)	(Occupational / Controlled Exposure Environment)
Spatial Average (averaged over the whole body)	0.08	0.4
Spatial Peak (averaged over any 1 g of tissue)	2.0	10
Spatial Peak (hands/wrists/feet/ankles averaged over 10 g)	4.0	20.0

Population/Uncontrolled Environments are defined as locations where there is the exposure of individual who have no knowledge or control of their exposure.

Occupational/Controlled Environments are defined as locations where there is exposure that may be incurred by people who are aware of the potential for exposure (i.e. as a result of employment or occupation).

General Population/Uncontrolled environments Spatial Peak limit 1.6W/kg (FCC) & 2 W/kg (CE) applied to the EUT.

FACILITIES AND ACCREDITATION

The test site used by Bay Area Compliance Laboratories Corp. (Shenzhen) to collect data is located at

6/F, the 3rd Phase of WanLi Industrial Building,
Shi Hua Road, Fu Tian Free Trade Zone,
Shenzhen, Guangdong, P.R. of China

Additionally, Bay Area Compliance Laboratories Corp. (Shenzhen) is a National Institute of Standards and Technology (NIST) accredited laboratory, under the National Voluntary Laboratory Accredited Program (Lab Code 200707-0).



The current scope of accreditations can be found at <http://ts.nist.gov/Standards/scopes/2007070.htm>

DESCRIPTION OF TEST SYSTEM

These measurements were performed with ALSAS 10 Universal Integrated SAR Measurement system from APREL Laboratories.



ALSAS-10U System Description

ALSAS-10-U is fully compliant with the technical and scientific requirements of IEEE 1528, IEC 62209, CENELEC, ARIB, ACA, and the Federal Communications Commission. The system comprises of a six axes articulated robot which utilizes a dedicated controller. ALSAS-10U uses the latest methodologies. And FDTD modeling to provide a platform which is repeatable with minimum uncertainty.

Applications

Predefined measurement procedures compliant with the guidelines of CENELEC, IEEE, IEC, FCC, etc are utilized during the assessment for the device. Automatic detection for all SAR maxima are embedded within the core architecture for the system, ensuring that peak locations used for centering the zoom scan are within a 1mm resolution and a 0.05mm repeatable position. System operation range currently available up-to 6 GHz in simulated tissue.

Area Scans

Area scans are defined prior to the measurement process being executed with a user defined variable spacing between each measurement point (integral) allowing low uncertainty measurements to be conducted. Scans defined for FCC applications utilize a 10mm² step integral, with 1mm interpolation used to locate the peak SAR area used for zoom scan assessments.

Where the system identifies multiple SAR peaks (which are within 25% of peak value) the system will provide the user with the option of assessing each peak location individually for zoom scan averaging.

Zoom Scan (Cube Scan Averaging)

The averaging zoom scan volume utilized in the ALSAS-10U software is in the shape of a cube and the side dimension of a 1 g or 10 g mass is dependent on the density of the liquid representing the simulated tissue. A density of 1000 kg/m³ is used to represent the head and body tissue density and not the phantom liquid density, in order to be consistent with the definition of the liquid dielectric properties, i.e. the side length of the 1 g cube is 10mm, with the side length of the 10 g cube 21,5mm.

When the cube intersects with the surface of the phantom, it is oriented so that 3 vertices touch the surface of the shell or the center of a face is tangent to the surface. The face of the cube closest to the surface is modified in order to conform to the tangent surface.

The zoom scan integer steps can be user defined so as to reduce uncertainty, but normal practice for typical test applications (including FCC) utilize a physical step of 5x5x8 (8mmx8mmx5mm) providing a volume of 32mm in the X & Y axis, and 35mm in the Z axis.

ALSAS-10U Interpolation and Extrapolation Uncertainty

The overall uncertainty for the methodology and algorithms the used during the SAR calculation was evaluated using the data from IEEE 1528 based on the example f3 algorithm:

$$f_3(x, y, z) = A \frac{a^2}{\frac{a^2}{4} + x'^2 + y'^2} \cdot \left(e^{-\frac{2z}{a}} + \frac{a^2}{2(a + 2z)^2} \right)$$

Isotropic E-Field Probe

The isotropic E-Field probe has been fully calibrated and assessed for isotropicity, and boundary effect within a controlled environment. Depending on the frequency for which the probe is calibrated the method utilized for calibration will change.

The E-Field probe utilizes a triangular sensor arrangement as detailed in the diagram below:

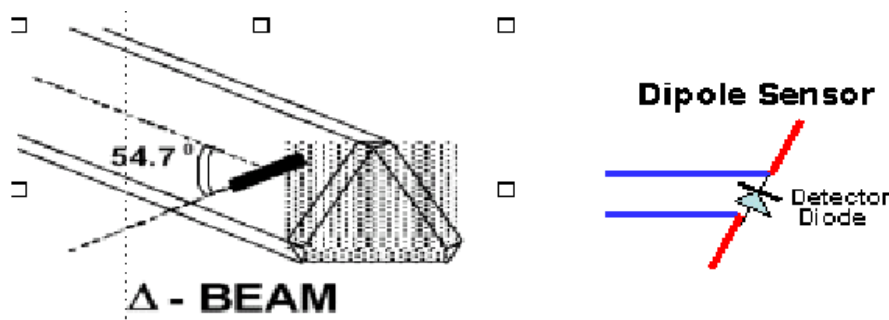

SAR is assessed with a calibrated probe which moves at a default height of 5mm from the center of the diode, which is mounted to the sensor, to the phantom surface (in the Z Axis). The 5mm offset height has been selected so as to minimize any resultant boundary effect due to the probe being in close proximity to the phantom surface.

The following algorithm is an example of the function used by the system for linearization of the output from the probe when measuring complex modulation schemes.

$$V_i = U_i + U_i^2 \cdot \frac{cf}{dcp_i}$$

Isotropic E-Field Probe Specification

Calibration in Air	Frequency Dependent Below 2 GHz Calibration in air performed in a TEM Cell Above 2 GHz Calibration in air performed in waveguide
Sensitivity	0.70 $\mu\text{V}/(\text{V}/\text{m})^2$ to 0.85 $\mu\text{V}/(\text{V}/\text{m})^2$
Dynamic Range	0.0005 W/kg to 100 W/kg
Isotropic Response	Better than 0.2 dB
Diode Compression Point (DCP)	Calibration for Specific Frequency
Probe Tip Radius	< 5 mm
Sensor Offset	1.56 (+/- 0.02 mm)
Probe Length	290 mm
Video Bandwidth	@ 500 Hz: 1 dB @ 1.02 kHz: 3 dB
Boundary Effect	Less than 2% for distance greater than 2.4 mm
Spatial Resolution	Diameter less than 5 mm Compliant with Standards

Boundary Detection Unit and Probe Mounting Device

ALSAS-10U incorporates a boundary detection unit with a sensitivity of 0.05mm for detecting all types of surfaces. The robust design allows for detection during probe tilt (probe normalize) exercises, and utilizes a second stage emergency stop. The signal electronics are fed directly into the robot controller for high accuracy surface detection in lateral and axial detection modes (X, Y, & Z).

The probe is mounted directly onto the Boundary Detection unit for accurate tooling and displacement calculations controlled by the robot kinematics. The probe is connect to an isolated probe interconnect where the output stage of the probe is fed directly into the amplifier stage of the Daq-Paq.

Daq-Paq (Analog to Digital Electronics)

ALSAS-10U incorporates a fully calibrated Daq-Paq (analog to digital conversion system) which has a 4 channel input stage, sent via a 2 stage auto-set amplifier module. The input signal is amplified accordingly so as to offer a dynamic range from 5 μV to 800mV. Integration of the fields measured is carried out at board level utilizing a Co-Processor which then sends the measured fields down into the main computational module in digitized form via an RS232 communications port. Probe linearity and duty cycle compensation is carried out within the main Daq-Paq module.

ADC	12 Bit
Amplifier Range	20 mV to 200 mV and 150 mV to 800 mV
Field Integration	Local Co-Processor utilizing proprietary integration algorithms
Number of Input Channels	4 in total 3 dedicated and 1 spare
Communication	Packet data via RS232

Axis Articulated Robot

ALSAS-10U utilizes a six axis articulated robot, which is controlled using a Pentium based real-time movement controller. The movement kinematics engine utilizes proprietary (Thermo CRS) interpolation and extrapolation algorithms, which allow full freedom of movement for each of the six joints within the working envelope. Utilization of joint 6 allows for full probe rotation with a tolerance better than 0.05mm around the central axis.



Robot/Controller Manufacturer	Thermo CRS
Number of Axis	Six independently controlled axis
Positioning Repeatability	0.05 mm
Controller Type	Single phase Pentium based C500C
Robot Reach	710 mm
Communication	RS232 and LAN compatible

ALSAS Universal Workstation

ALSAS Universal workstation allows for repeatability and fast adaptability. It allows users to do calibration, testing and measurements using different types of phantoms with one set up, which significantly speeds up the measurement process.

Universal Device Positioner

The universal device positioner allows complete freedom of movement of the EUT. Developed to hold a EUT in a free-space scenario any additional loading attributable to the material used in the construction of the positioner has been eliminated. Repeatability has been enhanced through the linear scales which form the design used to indicate positioning for any given test scenario in all major axes. A 15° tilt indicator is included for the of aid cheek to tilt movements for head SAR analysis. Overall uncertainty for measurements have been reduced due to the design of the Universal device positioner, which allows positioning of a device in as near to a free-space scenario as possible, and by providing the means for complete repeatability.



Phantom Types

The ALSAS-10U allows the integration of multiple phantom types. SAM Phantoms fully compliant with IEEE 1528, Universal Phantom, and Universal Flat.

APREL SAM Phantoms

The SAM phantoms developed using the IEEE SAM CAD file. They are fully compliant with the requirements for both IEEE 1528 and FCC Supplement C. Both the left and right SAM phantoms are interchangeable, transparent and include the IEEE 1528 grid with visible NF and MB lines.

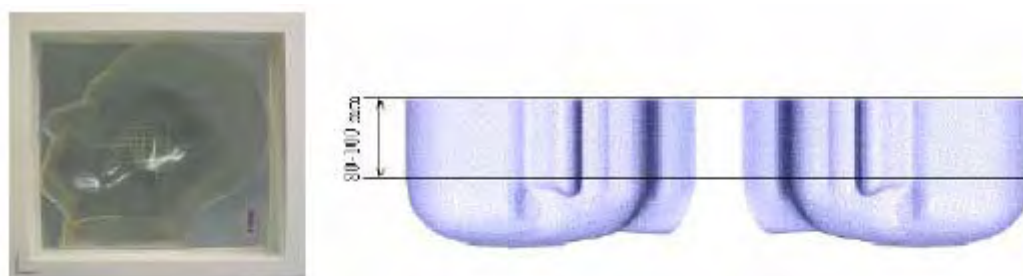

APREL Laboratories Universal Phantom

The Universal Phantom is used on the ALSAS-10U as a system validation phantom. The Universal Phantom has been fully validated both experimentally from 800MHz to 6GHz and numerically using XFDTD numerical software.

The shell thickness is 2mm overall, with a 4mm spacer located at the NF/MB intersection providing an overall thickness of 6mm in line with the requirements of IEEE-1528.

The design allows for fast and accurate measurements, of handsets, by allowing the conservative SAR to be evaluated at on frequency for both left and right head experiments in one measurement.



Tissue Dielectric Parameters for Head and Body Phantoms

The head tissue dielectric parameters recommended by the IEEE SCC-34/SC-2 in P1528 have been incorporated in the following table. These head parameters are derived from planar layer models simulating the highest expected SAR for the dielectric properties and tissue thickness variations in a human head. Other head and body tissue parameters that have not been specified in P1528 are derived from the tissue dielectric parameters computed from the 4-Cole-Cole equations described in Reference [12] and extrapolated according to the head parameters specified in P1528.

Ingredients (% by weight)	Frequency (MHz)									
	450		835		915		1900		2450	
Tissue Type	Head	Body	Head	Body	Head	Body	Head	Body	Head	Body
Water	38.56	51.16	41.45	52.4	41.05	56.0	54.9	40.4	62.7	73.2
Salt (Nacl)	3.95	1.49	1.45	1.4	1.35	0.76	0.18	0.5	0.5	0.04
Sugar	56.32	46.78	56.0	45.0	56.5	41.76	0.0	58.0	0.0	0.0
HEC	0.98	0.52	1.0	1.0	1.0	1.21	0.0	1.0	0.0	0.0
Bactericide	0.19	0.05	0.1	0.1	0.1	0.27	0.0	0.1	0.0	0.0
Triton x-100	0.0	0.0	0.0	0.0	0.0	0.0	0.0	0.0	36.8	0.0
DGBE	0.0	0.0	0.0	0.0	0.0	0.0	44.92	0.0	0.0	26.7
Dielectric Constant	43.42	58.0	42.54	56.1	42.0	56.8	39.9	54.0	39.8	52.5
Conductivity (s/m)	0.85	0.83	0.91	0.95	1.0	1.07	1.42	1.45	1.88	1.78

Recommended Tissue Dielectric Parameters for Head and Body

Frequency (MHz)	Head Tissue		Body Tissue	
	ϵ_r	σ (S/m)	ϵ_r	σ (S/m)
150	52.3	0.76	61.9	0.80
300	45.3	0.87	58.2	0.92
450	43.5	0.87	56.7	0.94
835	41.5	0.90	55.2	0.97
900	41.5	0.97	55.0	1.05
915	41.5	0.98	55.0	1.06
1450	40.5	1.20	54.0	1.30
1610	40.3	1.29	53.8	1.40
1800-2000	40.0	1.40	53.3	1.52
2450	39.2	1.80	52.7	1.95
3000	38.5	2.40	52.0	2.73
5800	35.3	5.27	48.2	6.00

EQUIPMENT LIST AND CALIBRATION

Equipments List & Calibration Info

Equipment	Model	Calibration Date	S/N
CRS F3 robot	ALS-F3	N/A	RAF0805352
CRS F3 Software	ALS-F3-SW	N/A	N/A
CRS C500C controller	ALS-C500	N/A	RCF0805379
Probe mounting device & Boundary Detection Sensor System	ALS-PMDPS-3	N/A	120-00270
Universal Work Station	ALS-UWS	N/A	100-00157
Data Acquisition Package	ALS-DAQ-PAQ-3	N/A	110-00212
Miniature E-Field Probe	ALS-E-020	2011-07-20	500-00283
Dipole, 835 MHz	ALS-D-835-S-2	2010-11-04	210-00564
Dipole,1900 MHz	ALS-D-1900-S-2	2010-11-04	210-00715
Dipole Spacer	ALS-DS-U	N/A	250-00907
R&S, universal Radio Communication Tester	CMU200	2011-06-28	1100.0008.02
Device holder/Positioner	ALS-H-E-SET-2	N/A	170-00510
Left ear SAM phantom	ALS-P-SAM-L	N/A	130-00311
Right ear SAM phantom	ALS-P-SAM-R	N/A	140-00359
Uni Phantom	ALS-P-UP-1	N/A	150-00413
Simulated Tissue 835 MHz Head	ALS-TS-835-H	Each Time	280-01054
Simulated Tissue 835 MHz Body	ALS-TS-835-B	Each Time	280-02151
Simulated Tissue 1900 MHz Head	ALS-TS-1900-H	Each Time	290-01105
Simulated Tissue 1900 MHz Body	ALS-TS-1900-B	Each Time	290-02201
Signal Generator	HP8648C	2010-09-18	3426A01345
Power Amplifier	5S1G4	N/A	71377
Spectrum Analyzer	FSEM30	2011-07-05	849720/019

SAR MEASUREMENT SYSTEM VERIFICATION

Liquid Verification

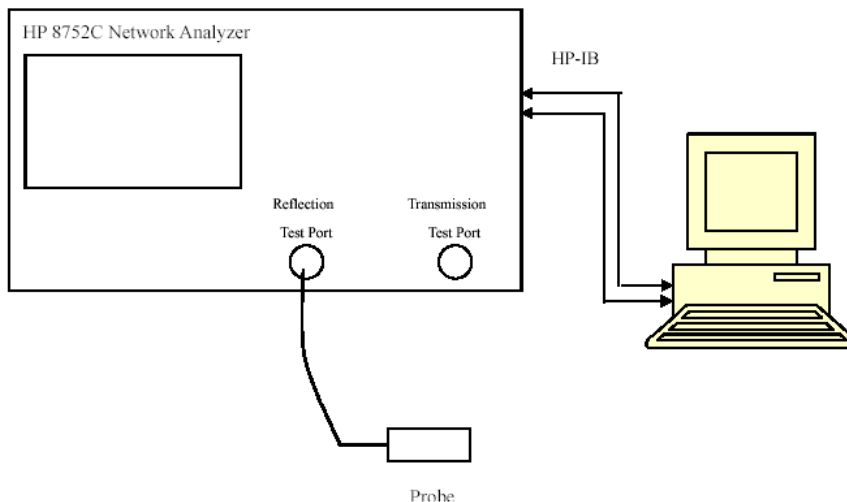

Liquid Verification Setup Block Diagram

Liquid Verification Results

Frequency (MHz)	Liquid Type	Liquid Parameter		Result
		ϵ_r	σ (S/m)	
835	Head	41.24	0.91	In Tolerance
835	Body	55.50	0.99	In Tolerance
1900	Head	40.11	1.44	In Tolerance
1900	Body	54.18	1.48	In Tolerance

**Liquid Verification was performed on 2011-07-28 and 2011-07-29*

Please refer to the following tables.

850 MHz Head			850 MHz Body		
Frequency (MHz)	e'	e''	Frequency (MHz)	e'	e''
824	41.342587	19.549610	824	55.553037	21.461691
824.5	41.321722	19.558685	824.5	55.516188	21.457228
825	41.278830	19.526033	825	55.539564	21.463949
825.5	41.210521	19.516357	825.5	55.459404	21.402983
826	41.183590	19.521858	826	55.482154	21.437874
826.5	41.243079	19.514190	826.5	55.520895	21.410903
827	41.297561	19.507845	827	55.521631	21.431606
827.5	41.302852	19.515030	827.5	55.516294	21.376477
828	41.220496	19.472497	828	55.509752	21.377583
828.5	41.298214	19.512400	828.5	55.521541	21.427475
829	41.281234	19.515175	829	55.504042	21.399280
829.5	41.334935	19.582614	829.5	55.540310	21.484326
830	41.300060	19.558695	830	55.513119	21.459771
830.5	41.298890	19.504421	830.5	55.527281	21.397462
831	41.234365	19.562444	831	55.480954	21.468997
831.5	41.266308	19.551563	831.5	55.492725	21.429833
832	41.240292	19.483406	832	55.442706	21.403004
832.5	41.220392	19.549906	832.5	55.424413	21.430642
833	41.243013	19.468323	833	55.451912	21.374595
833.5	41.248054	19.548699	833.5	55.501340	21.376560
834	41.246924	19.494755	834	55.485768	21.309307
834.5	41.257827	19.521085	834.5	55.467822	21.380917
835	41.239872	19.518925	835	55.499014	21.378636
835.5	41.270133	19.539741	835.5	55.521485	21.324558
836	41.233234	19.469964	836	55.452651	21.305361
836.5	41.252927	19.545765	836.5	55.418012	21.361139
837	41.231156	19.492673	837	55.494616	21.319455
837.5	41.209171	19.512489	837.5	55.450262	21.335005
838	41.263456	19.526358	838	55.485076	21.342166
838.5	41.203303	19.484276	838.5	55.446331	21.372009
839	41.173200	19.511544	839	55.484861	21.317377
839.5	41.195294	19.503334	839.5	55.502046	21.292888
840	41.193502	19.465657	840	55.499409	21.330729
840.5	41.231266	19.458179	840.5	55.513217	21.269233
841	41.221813	19.484743	841	55.441842	21.284352
841.5	41.164677	19.488663	841.5	55.466326	21.278883
842	41.169753	19.438846	842	55.418124	21.268769
842.5	41.172719	19.436081	842.5	55.469233	21.247549
843	41.186530	19.471412	843	55.457348	21.288818
843.5	41.180666	19.455693	843.5	55.447921	21.280086
844	41.157840	19.470532	844	55.408054	21.304919
844.5	41.145905	19.523347	844.5	55.440173	21.290948
845	41.100160	19.421523	845	55.382128	21.268558
845.5	41.130326	19.441753	845.5	55.397484	21.239403
846	41.100919	19.468737	846	55.341700	21.194618
846.5	41.095885	19.437528	846.5	55.392097	21.227717
847	41.105737	19.422564	847	55.395953	21.224769
847.5	41.071075	19.430598	847.5	55.386773	21.216063
848	41.071504	19.418359	848	55.360921	21.192268
848.5	41.063925	19.449246	848.5	55.385196	21.213717
849	41.002479	19.434399	849	55.327673	21.191593

1900 MHz Head			1900 MHz Body		
Frequency (MHz)	e'	e''	Frequency (MHz)	e'	e''
1850	40.349201	13.809692	1850	54.197165	14.227881
1851.2	40.327305	13.771466	1851.2	54.168712	14.233153
1852.4	40.349367	13.758672	1852.4	54.169119	14.216085
1853.6	40.301530	13.733701	1853.6	54.154873	14.216119
1854.8	40.300427	13.763388	1854.8	54.121098	14.211213
1856	40.302882	13.744238	1856	54.133572	14.190793
1857.2	40.284475	13.741306	1857.2	54.110229	14.176570
1858.4	40.272758	13.734172	1858.4	54.161496	14.211335
1859.6	40.268622	13.744035	1859.6	54.145237	14.213306
1860.8	40.237630	13.696296	1860.8	54.100344	14.196043
1862	40.270332	13.720239	1862	54.080617	14.189814
1863.2	40.259302	13.743782	1863.2	54.062971	14.223142
1864.4	40.268944	13.701549	1864.4	54.152034	14.208267
1865.6	40.215270	13.662084	1865.6	54.155980	14.203277
1866.8	40.200967	13.675249	1866.8	54.118352	14.202185
1868	40.227359	13.659711	1868	54.125650	14.208990
1869.2	40.227059	13.695077	1869.2	54.183343	14.233825
1870.4	40.221858	13.693250	1870.4	54.150211	14.221206
1871.6	40.228571	13.680814	1871.6	54.186930	14.231186
1872.8	40.222508	13.716683	1872.8	54.176716	14.235264
1874	40.221079	13.740314	1874	54.187711	14.295232
1875.2	40.235680	13.701209	1875.2	54.204068	14.274822
1876.4	40.238981	13.712588	1876.4	54.180298	14.276273
1877.6	40.179875	13.757281	1877.6	54.119350	14.274149
1878.8	40.222039	13.747045	1878.8	54.186831	14.300916
1880	40.210534	13.774007	1880	54.183938	14.320966
1881.2	40.181428	13.778068	1881.2	54.149094	14.306222
1882.4	40.207990	13.786984	1882.4	54.124637	14.327171
1883.6	40.187760	13.785476	1883.6	54.177114	14.337511
1884.8	40.225924	13.827161	1884.8	54.225730	14.347707
1886	40.191285	13.856446	1886	54.150408	14.317732
1887.2	40.223269	13.849467	1887.2	54.110581	14.334049
1888.4	40.198108	13.810968	1888.4	54.159146	14.344082
1889.6	40.168618	13.843146	1889.6	54.112768	14.328990
1890.8	40.130908	13.818825	1890.8	54.057059	14.303632
1892	40.187855	13.826772	1892	54.150768	14.362229
1893.2	40.165399	13.836048	1893.2	54.218622	14.380813
1894.4	40.145704	13.815746	1894.4	54.136827	14.319512
1895.6	40.136074	13.835291	1895.6	54.177858	14.377822
1896.8	40.122006	13.823776	1896.8	54.159280	14.352064
1898	40.130702	13.828541	1898	54.155309	14.357981
1899.2	40.103922	13.806731	1899.2	54.193563	14.384924
1900.4	40.117002	13.808678	1900.4	54.176114	14.327961
1901.6	40.141260	13.828109	1901.6	54.248901	14.375430
1902.8	40.141568	13.819772	1902.8	54.276873	14.359036
1904	40.103326	13.799233	1904	54.229962	14.367439
1905.2	40.137225	13.843143	1905.2	54.214957	14.353376
1906.4	40.129768	13.827495	1906.4	54.258173	14.348990
1907.6	40.155773	13.830303	1907.6	54.224072	14.387060
1908.8	40.137016	13.849611	1908.8	54.261687	14.372687
1910	40.161155	13.878174	1910	54.261647	14.382535

System Accuracy Verification

Prior to the assessment, the system validation kit was used to test whether the system was operating within its specifications of $\pm 10\%$. The validation results are tabulated below. And also the corresponding SAR plot is attached as well in the SAR plots files.

System Verification Setup Block Diagram

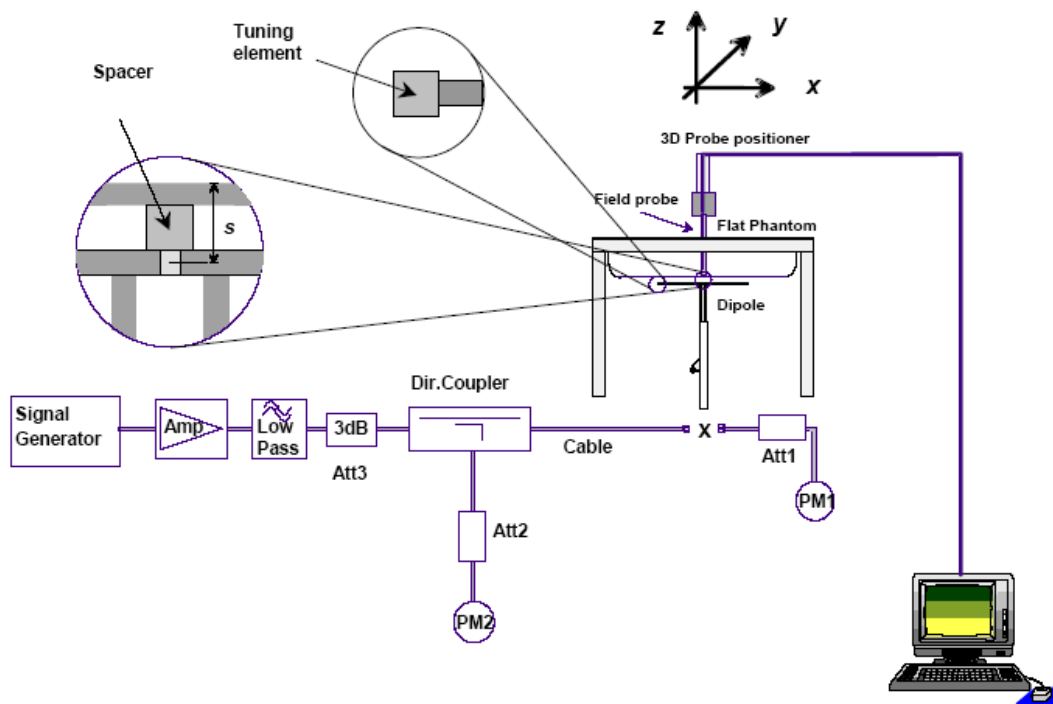

System Check Results

Date	Frequency (MHz)	Liquid Type	1 g SAR (W/Kg)	Target Value (W/Kg)	Result
2011-07-28	835	Head	9.645	9.51	In Tolerance
2011-07-29	1900	Head	40.364	38.90	In Tolerance
2011-07-28	835	Body	9.562	9.50	In Tolerance
2011-07-29	1900	Body	38.842	39.70	In Tolerance

* All SAR values are normalized to 1 Watt forward power.

SAR SYSTEM VALIDATION DATA**Test Laboratory: Bay Area Compliance Lab Corp. (Shenzhen)****System Performance Check 835 MHz, Head Liquid****Dipole 835 MHz; Type: ALS-D-835-S-2; S/N: 210-00564**

Product Data

Device Name : Dipole 835 MHz
Serial No. : 210-00564
Type : Dipole
Model : ALS-D-835-S-2
Frequency : 835.00 MHz
Max. Transmit Pwr : 1 W
Drift Time : 3 min(s)
Power Drift-Start : 10.365 W/kg
Power Drift-Finish : 9.902 W/kg
Power Drift (%) : -1.410

Phantom Data

Name : APREL-Uni
Type : Uni-Phantom
Size (mm) : 280 x 280 x 200
Serial No. : System Default
Location : Center
Description : Default
Phantom Data

Tissue Data

Type : HEAD
Serial No. : 270-01002
Frequency : 835.00 MHz
Last Calib. Date : 28-Jul -2011
Temperature : 20.00 °C
Ambient Temp. : 21.00 °C
Humidity : 56.00 RH%
Epsilon : 41.24 F/m
Sigma : 0.91 S/m
Density : 1000.00 kg/cu. m

Probe Data

Name : E-Field
Model : E-020
Type : E-Field Triangle
Serial No. : 500-00283
Last Calib. Date : 20-Jul-2011
Frequency : 835.00 MHz
Duty Cycle Factor : 1
Conversion Factor : 6.5
Probe Sensitivity : 1.20 1.20 1.20 $\mu\text{V}/(\text{V}/\text{m})^2$
Compression Point : 95.00 mV
Offset : 1.56 mm

Measurement Data

Crest Factor : 1
Scan Type : Complete
Tissue Temp. : 21.00 °C
Ambient Temp. : 21.00 °C
Area Scan : 7x9x1 : Measurement x=10mm, y=10mm, z=4mm
Zoom Scan : 7x7x7 : Measurement x=5mm, y=5mm, z=5mm

1 gram SAR value : 9.645 W/kg
10 gram SAR value : 6.124 W/kg
Area Scan Peak SAR : 9.752 W/kg
Zoom Scan Peak SAR : 15.265 W/kg

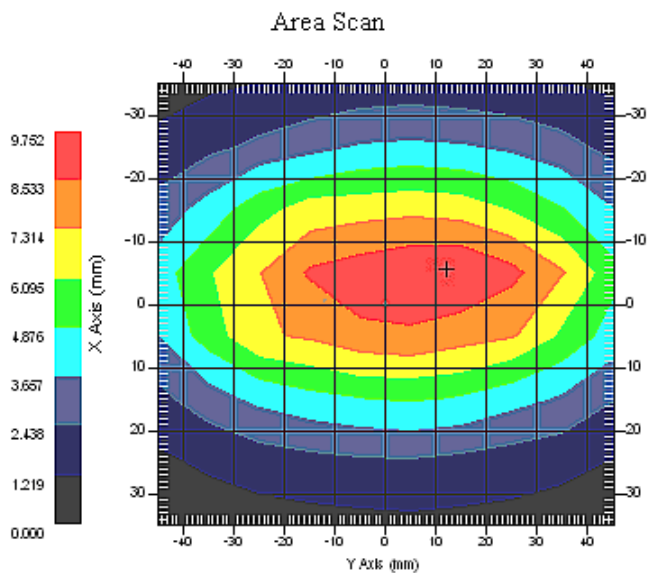

835 MHz System Validation with Head Tissue

Test Laboratory: Bay Area Compliance Lab Corp. (Shenzhen)**System Performance Check 835 MHz, Body Liquid****Dipole 835 MHz; Type: ALS-D-835-S-2; S/N: 210-00564**

Product Data

Device Name : Dipole 835 MHz
Serial No. : 210-00564
Type : Dipole
Model : ALS-D-835-S-2
Frequency : 835.00 MHz
Max. Transmit Pwr : 1 W
Drift Time : 3 min(s)
Power Drift-Start : 10.130 W/kg
Power Drift-Finish : 9.913 W/kg
Power Drift (%) : -2.301

Phantom Data

Name : APREL-Uni
Type : Uni-Phantom
Size (mm) : 280 x 280 x 200
Serial No. : System Default
Location : Center
Description : Default
Phantom Data

Tissue Data

Type : Body
Serial No. : 270-02101
Frequency : 835.00 MHz
Last Calib. Date : 28-Jul -2011
Temperature : 20.00 °C
Ambient Temp. : 21.00 °C
Humidity : 56.00 RH%
Epsilon : 55.50 F/m
Sigma : 0.99 S/m
Density : 1000.00 kg/cu. m

Probe Data

Name : E-Field
Model : E-020
Type : E-Field Triangle
Serial No. : 500-00283
Last Calib. Date : 20-Jul-2011
Frequency : 835.00 MHz
Duty Cycle Factor : 1
Conversion Factor : 6.7
Probe Sensitivity : 1.20 1.20 1.20 $\mu\text{V}/(\text{V}/\text{m})^2$
Compression Point : 95.00 mV
Offset : 1.56 mm

Measurement Data

Crest Factor : 1
Scan Type : Complete
Tissue Temp. : 21.00 °C
Ambient Temp. : 21.00 °C
Area Scan : 7x9x1 : Measurement x=10mm, y=10mm, z=4mm
Zoom Scan : 7x7x7 : Measurement x=5mm, y=5mm, z=5mm

1 gram SAR value : 9.562 W/kg
10 gram SAR value : 6.120 W/kg
Area Scan Peak SAR : 9.485 W/kg
Zoom Scan Peak SAR : 15.012 W/kg

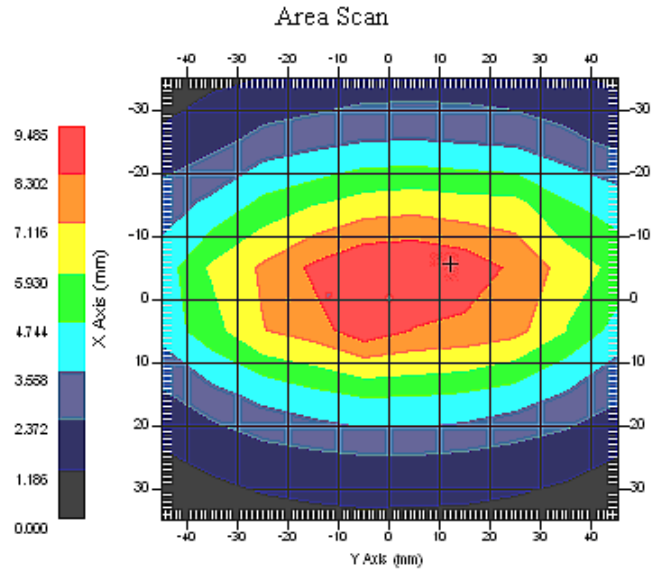

835 MHz System Validation with Body Tissue

Test Laboratory: Bay Area Compliance Lab Corp. (Shenzhen)**System Performance Check 1900 MHz, Head Tissue****Dipole 1900 MHz; Type: ALS-D-1900-S-2; S/N: 210-00715**

Product Data

Device Name : Dipole 1900MHz
Serial No. : 210-00715
Type : Dipole
Model : ALS-D-1900-S-2
Frequency : 1900.00 MHz
Max. Transmit Pwr : 1 W
Drift Time : 3 min(s)
Power Drift-Start : 40.489 W/kg
Power Drift-Finish : 40.804 W/kg
Power Drift (%) : 1.724

Phantom Data

Name : APREL-Uni
Type : Uni-Phantom
Size (mm) : 280 x 280 x 200
Serial No. : System Default
Location : Center
Description : Default

Tissue Data

Type : HEAD
Serial No. : 295-01103
Frequency : 1900.00 MHz
Last Calib. Date : 28-Jul-2011
Temperature : 20.00 °C
Ambient Temp. : 21.00 °C
Humidity : 56.00 RH%
Epsilon : 40.11 F/m
Sigma : 1.44 S/m
Density : 1000.00 kg/cu. M

Probe Data

Name : E-Field
Model : E-020
Type : E-Field Triangle
Serial No. : 500-00283
Last Calib. Date : 20-Jul-2011
Frequency : 1900.00 MHz
Duty Cycle Factor : 1
Conversion Factor : 5.25
Probe Sensitivity : 1.20 1.20 1.20 $\mu\text{V}/(\text{V}/\text{m})^2$
Compression Point : 95.00 mV
Offset : 1.56 mm

Measurement Data

Crest Factor : 1
Scan Type : Complete
Tissue Temp. : 20.00 °C
Ambient Temp. : 20.00 °C
Area Scan : 7x9x1 : Measurement x=10mm, y=10mm, z=4mm
Zoom Scan : 7x7x7 : Measurement x=5mm, y=5mm, z=5mm

1 gram SAR value : 40.364 W/kg
10 gram SAR value : 20.512 W/kg
Area Scan Peak SAR : 41.256 W/kg
Zoom Scan Peak SAR : 72.841 W/kg

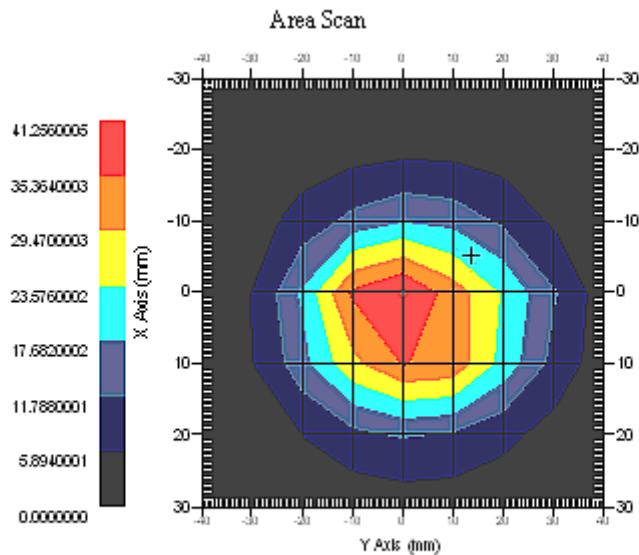

1900 MHz System Validation with Head Tissue

Test Laboratory: Bay Area Compliance Lab Corp. (Shenzhen)**System Performance Check 1900 MHz, Body Tissue****Dipole 1900 MHz; Type: ALS-D-1900-S-2; S/N: 210-00715**

Product Data

Device Name : Dipole 1900MHz
Serial No. : 210-00715
Type : Dipole
Model : ALS-D-1900-S-2
Frequency : 1900.00 MHz
Max. Transmit Pwr : 1 W
Drift Time : 3 min(s)
Power Drift-Start : 40.562 W/kg
Power Drift-Finish : 40.106 W/kg
Power Drift (%) : -1.351

Phantom Data

Name : APREL-Uni
Type : Uni-Phantom
Size (mm) : 280 x 280 x 200
Serial No. : System Default
Location : Center
Description : Default

Tissue Data

Type : Body
Serial No. : 295-02102
Frequency : 1900.00 MHz
Last Calib. Date : 28-Jul-2011
Temperature : 20.00 °C
Ambient Temp. : 21.00 °C
Humidity : 56.00 RH%
Epsilon : 54.18 F/m
Sigma : 1.48 S/m
Density : 1000.00 kg/cu. m

Probe Data

Name : E-Field
Model : E-020
Type : E-Field Triangle
Serial No. : 500-00283
Last Calib. Date : 20-Jul-2011
Frequency : 1900.00 MHz
Duty Cycle Factor : 1
Conversion Factor : 5.15
Probe Sensitivity : 1.20 1.20 1.20 $\mu\text{V}/(\text{V}/\text{m})^2$
Compression Point : 95.00 mV
Offset : 1.56 mm

Measurement Data

Crest Factor : 1
Scan Type : Complete
Tissue Temp. : 20.00 °C
Ambient Temp. : 21.00 °C
Area Scan : 7x9x1 : Measurement x=10mm, y=10mm, z=4mm
Zoom Scan : 7x7x7 : Measurement x=5mm, y=5mm, z=5mm

1 gram SAR value : 38.842 W/kg
 10 gram SAR value : 19.564 W/kg
 Area Scan Peak SAR : 40.412 W/kg
 Zoom Scan Peak SAR : 70.155 W/kg

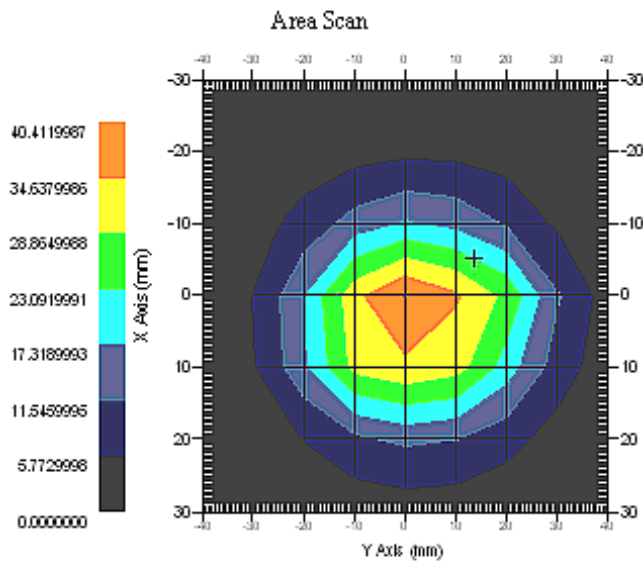

1900 MHz System Validation with Body Tissue

EUT TEST STRATEGY AND METHODOLOGY

Test Positions for Device Operating Next to a Person’s Ear

This category includes most wireless handsets with fixed, retractable or internal antennas located toward the top half of the device, with or without a foldout, sliding or similar keypad cover. The handset should have its earpiece located within the upper ¼ of the device, either along the centerline or off-centered, as perceived by its users. This type of handset should be positioned in a normal operating position with the “test device reference point” located along the “vertical centerline” on the front of the device aligned to the “ear reference point”. The “test device reference point” should be located at the same level as the center of the earpiece region. The “vertical centerline” should bisect the front surface of the handset at its top and bottom edges. A “ear reference point” is located on the outer surface of the head phantom on each ear spacer. It is located 1.5 cm above the center of the ear canal entrance in the “phantom reference plane” defined by the three lines joining the center of each “ear reference point” (left and right) and the tip of the mouth.

A handset should be initially positioned with the earpiece region pressed against the ear spacer of a head phantom. For the SCC-34/SC-2 head phantom, the device should be positioned parallel to the “N-F” line defined along the base of the ear spacer that contains the “ear reference point”. For interim head phantoms, the device should be positioned parallel to the cheek for maximum RF energy coupling. The “test device reference point” is aligned to the “ear reference point” on the head phantom and the “vertical centerline” is aligned to the “phantom reference plane”. This is called the “initial ear position”. While maintaining these three alignments, the body of the handset is gradually adjusted to each of the following positions for evaluating SAR:

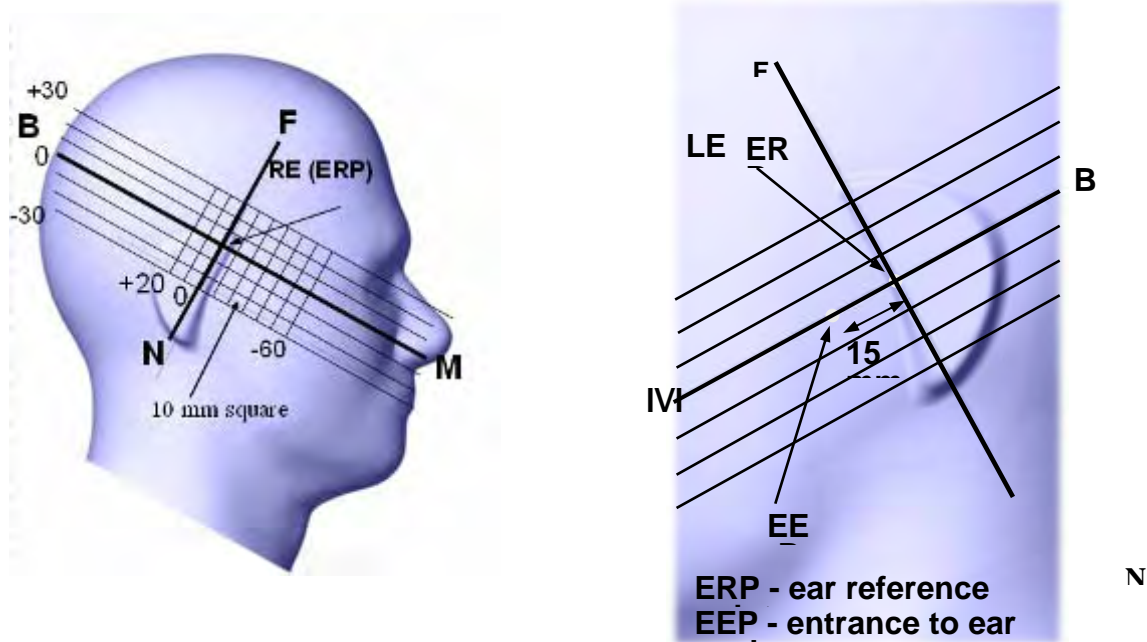

Cheek/Touch Position

The device is brought toward the mouth of the head phantom by pivoting against the “ear reference point” or along the “N-F” line for the SCC-34/SC-2 head phantom.

This test position is established:

- When any point on the display, keypad or mouthpiece portions of the handset is in contact with the phantom.
- (or) When any portion of a foldout, sliding or similar keypad cover opened to its intended self-adjusting normal use position is in contact with the cheek or mouth of the phantom.

For existing head phantoms – when the handset loses contact with the phantom at the pivoting point, rotation should continue until the device touches the cheek of the phantom or breaks its last contact from the ear spacer.

Cheek /Touch Position

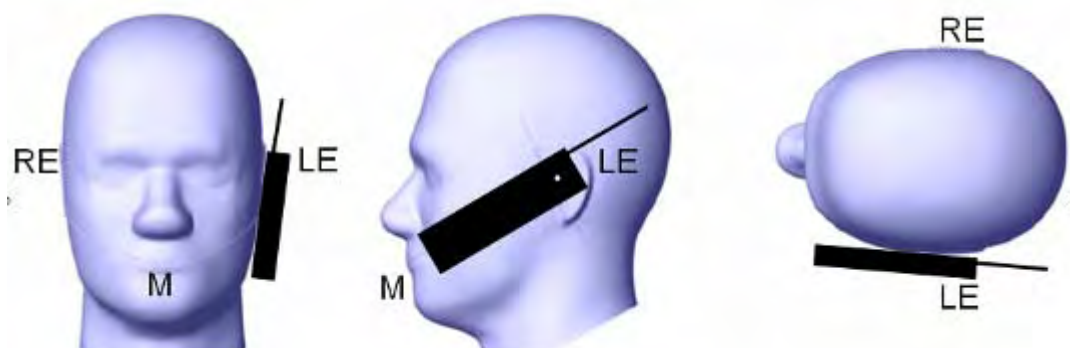

Ear/Tilt Position

With the handset aligned in the “Cheek/Touch Position”:

1) If the earpiece of the handset is not in full contact with the phantom’s ear spacer (in the “Cheek/Touch position”) and the peak SAR location for the “Cheek/Touch” position is located at the ear spacer region or corresponds to the earpiece region of the handset, the device should be returned to the “initial ear position” by rotating it away from the mouth until the earpiece is in full contact with the ear spacer.

2) (otherwise) The handset should be moved (translated) away from the cheek perpendicular to the line passes through both “ear reference points” (note: one of these ear reference points may not physically exist on a split head model) for approximate 2-3 cm. While it is in this position, the device handset is tilted away from the mouth with respect to the “test device reference point” until the inside angle between the vertical centerline on the front surface of the phone and the horizontal line passing through the ear reference point is by 15 80°. After the tilt, it is then moved (translated) back toward the head perpendicular to the line passes through both “ear reference points” until the device touches the phantom or the ear spacer. If the antenna touches the head first, the positioning process should be repeated with a tilt angle less than 15° so that the device and its antenna would touch the phantom simultaneously. This test position may require a device holder or positioner to achieve the translation and tilting with acceptable positioning repeatability.

If a device is also designed to transmit with its keypad cover closed for operating in the head position, such positions should also be considered in the SAR evaluation. The device should be tested on the left and right side of the head phantom in the “Cheek/Touch” and “Ear/Tilt” positions. When applicable, each configuration should be tested with the antenna in its fully extended and fully retracted positions. These test configurations should be tested at the high, middle and low frequency channels of each operating mode; for example, AMPS, CDMA, and TDMA. If the SAR measured at the middle channel for each test configuration (left, right, Cheek/Touch, Tile/Ear, extended and retracted) is at least 2.0 dB lower than the SAR limit, testing at the high and low channels is optional for such test configuration(s). If the transmission band of the test device is less than 10 MHz, testing at the high and low frequency channels is optional.

Ear /Tilt 15° Position

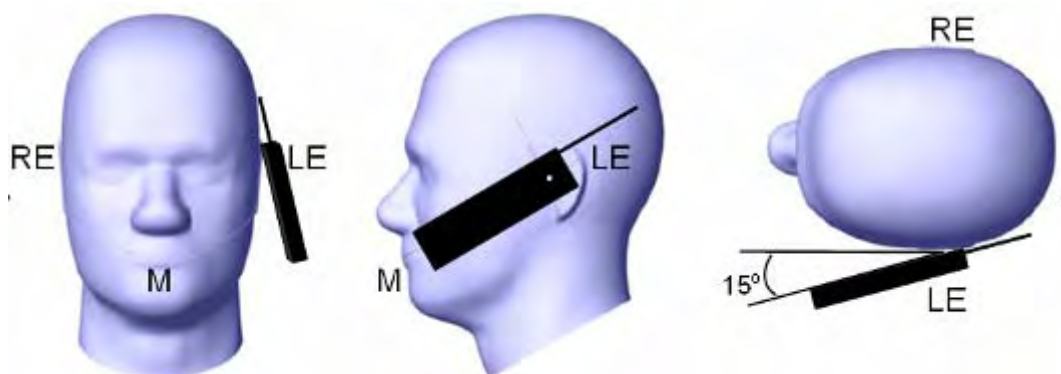

Test positions for body-worn and other configurations

Body-worn operating configurations should be tested with the belt-clips and holsters attached to the device and positioned against a flat phantom in normal use configurations. Devices with a headset output should be tested with a headset connected to the device. When multiple accessories that do not contain metallic components are supplied with the device, the device may be tested with only the accessory that dictates the closest spacing to the body. When multiple accessories that contain metallic components are supplied with the device, the device must be tested with each accessory that contains a unique metallic component. If multiple accessories share an identical metallic component (e.g., the same metallic belt-clip used with different holsters with no other metallic components), only the accessory that dictates the closest spacing to the body must be tested.

Body-worn accessories may not always be supplied or available as options for some devices that are intended to be authorized for body-worn use. A separation distance of 1.5 cm between the back of the device and a flat phantom is recommended for testing body-worn SAR compliance under such circumstances. Other separation distances may be used, but they should not exceed 2.5 cm. In these cases, the device may use body-worn accessories that provide a separation distance greater than that tested for the device provided however that the accessory contains no metallic components.

SAR Evaluation Procedure

The evaluation was performed with the following procedure:

Step 1: Measurement of the SAR value at a fixed location above the ear point or central position was used as a reference value for assessing the power drop. The SAR at this point is measured at the start of the test and then again at the end of the testing.

Step 2: The SAR distribution at the exposed side of the head was measured at a distance of 4 mm from the inner surface of the shell. The area covered the entire dimension of the head or EUT and the horizontal grid spacing was 10 mm x 10 mm. Based on these data, the area of the maximum absorption was determined by spline interpolation. The first Area Scan covers the entire dimension of the EUT to ensure that the hotspot was correctly identified.

Step 3: Around this point, a volume of 35 mm x 35 mm x 35 mm was assessed by measuring 7x 7 x 7 points. On the basis of this data set, the spatial peak SAR value was evaluated under the following procedure:

- 1) The data at the surface were extrapolated, since the center of the dipoles is 1.2 mm away from the tip of the probe and the distance between the surface and the lowest measuring point is 1.3 mm. The extrapolation was based on a least square algorithm. A polynomial of the fourth order was calculated through the points in z-axes. This polynomial was then used to evaluate the points between the surface and the probe tip.
- 2) The maximum interpolated value was searched with a straightforward algorithm. Around this maximum the SAR values averaged over the spatial volumes (1 g or 10 g) were computed by the 3D-Spline interpolation algorithm. The 3D-Spline is composed of three one dimensional splines with the "Not a knot"-condition (in x, y and z-directions). The volume was integrated with the trapezoidal-algorithm. One thousand points (10 x 10 x 10) were interpolated to calculate the averages.

All neighboring volumes were evaluated until no neighboring volume with a higher average value was found.

Step 4: Re-measurement of the SAR value at the same location as in Step 1. If the value changed by more than 5%, the evaluation was repeated.

OUTPUT POWER VERIFICATION

Test Block Diagram and Procedure

The RF output of the transmitter was connected to the input of the spectrum analyzer through sufficient attenuation.

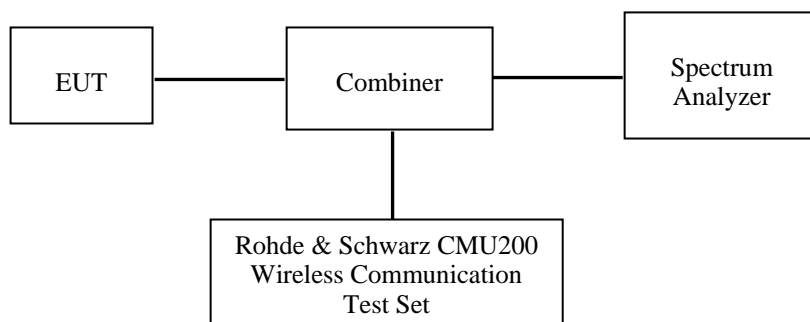

Test Results

GSM:

Band	Frequency (MHz)	Conducted Output Power	
		(dBm)	(Watt)
Cellular	824.2	32.28	1.690
	836.6	32.38	1.729
	848.8	32.47	1.766
PCS	1850.2	30.44	1.106
	1880.0	30.50	1.122
	1909.8	30.58	1.142

GPRS:

Band	Channel No.	Frequency (MHz)	RF Output Power (dBm)			
			1 slot	2 slots	3 slots	4 slots
Cellular	128	824.2	32.21	31.71	29.27	29.14
	190	836.6	32.32	31.61	29.35	29.31
	251	848.8	32.43	31.43	29.41	29.38
PCS	512	1850.2	30.30	29.71	27.82	27.68
	661	1880.0	30.33	29.77	27.86	27.70
	810	1909.8	30.42	29.90	27.98	27.86

For SAR, the time based average power is relevant, the difference in between depends on the duty cycle of the TDMA signal.

Number of Time slot	1	2	3	4
Duty Cycle	1:8	1:4	1:2.66	1:2
Time based Ave. power compared to slotted Ave. power	-9 dB	-6 dB	-4.25 dB	-3 dB
Crest Factor	8	4	2.66	2

The time based average power

Band	Channel No	Frequency (MHz)	Time based average Power (dBm)			
			1 slot	2 slots	3 slots	4 slots
Cellular	128	824.2	23.21	25.71	25.02	26.14
	190	836.6	23.32	25.61	25.10	26.31
	251	848.8	23.43	25.43	25.16	26.38
PCS	512	1850.2	21.30	23.71	23.57	24.68
	661	1880.0	21.33	23.77	23.61	24.70
	810	1909.8	21.42	23.90	23.73	24.86

SAR SIMULTANEOUS TRANSMISSION EVALUATION

SIMULTANEOUS TRANSMISSION CONSIDERATION

Stand-alone and simultaneous SAR evaluation for a cell phone with multiple transmitters is based on the output power and the antennas distance of each radio.

BT and GSM Antenna Location

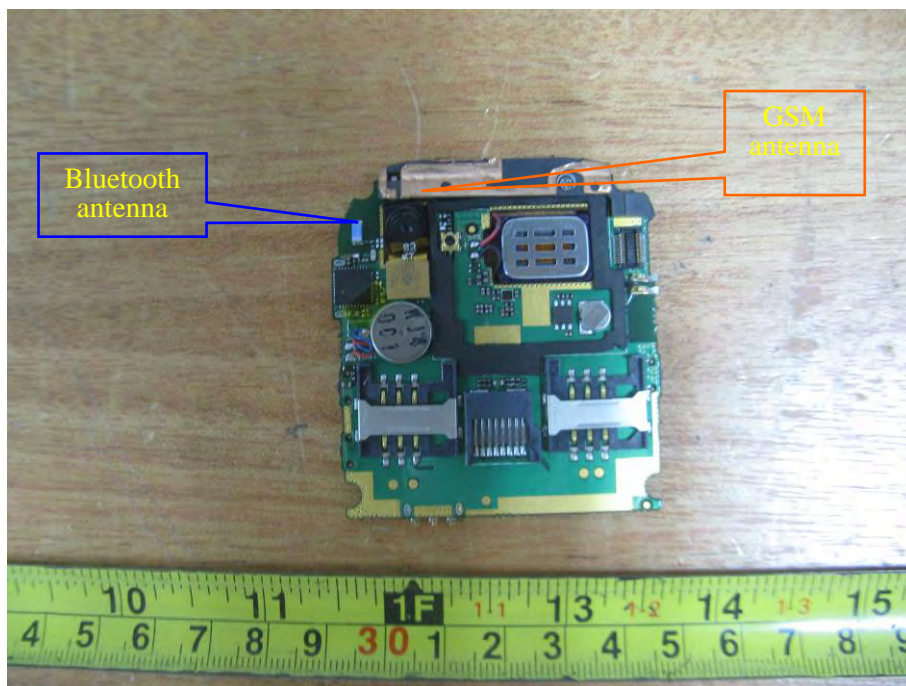

Individual transmitter	Stand-alone SAR	Simultaneous SAR
Bluetooth	Not required	Not required
GSM	Required	Not required

Note:

- 1) GSM can transmit simultaneously with Bluetooth
- 2) The distance between GSM and BT antenna is 0.8 cm
- 3) The output power of BT is 1.13 mw.

Simultaneous transmission SAR evaluation is not required for BT and GSM antennas.

SAR MEASUREMENT RESULTS

This page summarizes the results of the performed dosimetric evaluation. The plots with the corresponding SAR distributions, which reveal information about the location of the maximum SAR with respect to the device, could be found in this section.

SAR Test Data

Environmental Conditions

Temperature:	21° C
Relative Humidity:	50%
ATM Pressure:	1002 mbar

- Testing was performed by Cabin Hu on 2011-07-28---2011-07-30.

Note: This is a multi-slot class 12 device capable of 1, 2, 3, and 4 uplink timeslots and does not support dual transfer mode (DTM). During the head SAR scan, the device transmits with 1 uplink slot, during the body scan, transmission of 1 uplink slot with headset and 4 uplink slots have been investigated.

Cellular Band – Side sliding keypad opened

EUT Position	Frequency (MHz)		Test Mode	Antenna Type	Liquid	1g SAR Value (W/Kg)	FCC Limit (W/Kg)
	Channel	MHz					
Left Head Cheek	128 (Low)	824.2	GSM	Integral	Head	0.452	1.6
	190 (Middle)	836.6	GSM	Integral	Head	0.458	1.6
	251 (High)	848.8	GSM	Integral	Head	0.471	1.6
Left Head Tilt	128 (Low)	824.2	GSM	Integral	Head	/	1.6
	190 (Middle)	836.6	GSM	Integral	Head	/	1.6
	251 (High)	848.8	GSM	Integral	Head	0.258	1.6
Right Head Cheek	128 (Low)	824.2	GSM	Integral	Head	/	1.6
	190 (Middle)	836.6	GSM	Integral	Head	/	1.6
	251 (High)	848.8	GSM	Integral	Head	0.462	1.6
Right Head Tilt	128 (Low)	824.2	GSM	Integral	Head	/	1.6
	190 (Middle)	836.6	GSM	Integral	Head	/	1.6
	251 (High)	848.8	GSM	Integral	Head	0.255	1.6
Body-Worn Back	251 (High)	848.8	GSM	Integral	Body	0.175	1.6
	128 (Low)	824.2	GPRS (4slots)	Integral	Body	0.673	1.6
	190 (Middle)	836.6	GPRS (4slots)	Integral	Body	0.682	1.6
	251 (High)	848.8	GPRS (4slots)	Integral	Body	0.692	1.6

Cellular Band – Side sliding keypad closed

EUT Position	Frequency (MHz)		Test Mode	Antenna Type	Liquid	1g SAR Value (W/Kg)	FCC Limit (W/Kg)
	Channel	MHz					
Left Head Cheek	128 (Low)	824.2	GSM	Integral	Head	0.518	1.6
	190 (Middle)	836.6	GSM	Integral	Head	0.525	1.6
	251 (High)	848.8	GSM	Integral	Head	0.541	1.6
Left Head Tilt	128 (Low)	824.2	GSM	Integral	Head	/	1.6
	190 (Middle)	836.6	GSM	Integral	Head	/	1.6
	251 (High)	848.8	GSM	Integral	Head	0.352	1.6
Right Head Cheek	128 (Low)	824.2	GSM	Integral	Head	/	1.6
	190 (Middle)	836.6	GSM	Integral	Head	/	1.6
	251 (High)	848.8	GSM	Integral	Head	0.536	1.6
Right Head Tilt	128 (Low)	824.2	GSM	Integral	Head	/	1.6
	190 (Middle)	836.6	GSM	Integral	Head	/	1.6
	251 (High)	848.8	GSM	Integral	Head	0.341	1.6
Body-Worn Back	251 (High)	848.8	GSM	Integral	Body	0.206	1.6
	128 (Low)	824.2	GPRS (4slots)	Integral	Body	0.823	1.6
	190 (Middle)	836.6	GPRS (4slots)	Integral	Body	0.757	1.6
	251 (High)	848.8	GPRS (4slots)	Integral	Body	0.804	1.6

PCS Band –Side sliding keypad opened

EUT Position	Frequency (MHz)		Test Mode	Antenna Type	1g SAR Value (W/Kg)	FCC Limit (W/Kg)
	Channel	MHz				
Left Head Cheek	512 (Low)	1850.2	GSM	Integral	/	1.6
	661 (Middle)	1880.0	GSM	Integral	/	1.6
	810 (High)	1909.8	GSM	Integral	0.345	1.6
Left Head Tilt	512 (Low)	1850.2	GSM	Integral	/	1.6
	661 (Middle)	1880.0	GSM	Integral	/	1.6
	810 (High)	1909.8	GSM	Integral	0.255	1.6
Right Head Cheek	512 (Low)	1850.2	GSM	Integral	0.354	1.6
	661 (Middle)	1880.0	GSM	Integral	0.355	1.6
	810 (High)	1909.8	GSM	Integral	0.365	1.6
Right Head Tilt	512 (Low)	1850.2	GSM	Integral	/	1.6
	661 (Middle)	1880.0	GSM	Integral	/	1.6
	810 (High)	1909.8	GSM	Integral	0.273	1.6
Body-Worn Back	810 (High)	1909.8	GSM	Integral	0.142	1.6
	512 (Low)	1850.2	GPRS (4slots)	Integral	0.548	1.6
	661 (Middle)	1880.0	GPRS (4slots)	Integral	0.565	1.6
	810 (High)	1909.8	GPRS (4slots)	Integral	0.602	1.6

PCS Band –Side sliding keypad closed

EUT Position	Frequency (MHz)		Test Mode	Antenna Type	1g SAR Value (W/Kg)	FCC Limit (W/Kg)
	Channel	MHz				
Left Head Cheek	512 (Low)	1850.2	GSM	Integral	/	1.6
	661 (Middle)	1880.0	GSM	Integral	/	1.6
	810 (High)	1909.8	GSM	Integral	0.523	1.6
Left Head Tilt	512 (Low)	1850.2	GSM	Integral	/	1.6
	661 (Middle)	1880.0	GSM	Integral	/	1.6
	810 (High)	1909.8	GSM	Integral	0.456	1.6
Right Head Cheek	512 (Low)	1850.2	GSM	Integral	0.519	1.6
	661 (Middle)	1880.0	GSM	Integral	0.524	1.6
	810 (High)	1909.8	GSM	Integral	0.531	1.6
Right Head Tilt	512 (Low)	1850.2	GSM	Integral	/	1.6
	661 (Middle)	1880.0	GSM	Integral	/	1.6
	810 (High)	1909.8	GSM	Integral	0.472	1.6
Body-Worn Back	810 (High)	1909.8	GSM	Integral	0.162	1.6
	512 (Low)	1850.2	GPRS (4slots)	Integral	0.453	1.6
	661 (Middle)	1880.0	GPRS (4slots)	Integral	0.510	1.6
	810 (High)	1909.8	GPRS (4slots)	Integral	0.455	1.6

Test Laboratory: Bay Area Compliance Lab Corp. (Shenzhen)

Left Head Cheek-open keypad (835 MHz Low Channel)

Measurement Data

Test mode : GSM
 Crest Factor : 8
 Scan Type : Complete
 Area Scan : 13x9x1: Measurement x=10mm, y=10mm, z=4mm
 Zoom Scan : 7x7x7: Measurement x=5mm, y=5mm, z=5mm
 Power Drift-Start : 0.426 W/kg
 Power Drift-Finish : 0.415 W/kg
 Power Drift (%) : -2.321

Tissue Data

Type : HEAD
 Frequency : 835.00 MHz
 Epsilon : 41.24 F/m
 Sigma : 0.91 S/m
 Density : 1000.00 kg/cu. m

Probe Data

Serial No. : 500-00283
 Frequency : 835.00 MHz
 Duty Cycle Factor : 8
 Conversion Factor : 6.5
 Probe Sensitivity : 1.20 1.20 1.20 $\mu\text{V}/(\text{V}/\text{m})^2$
 Compression Point : 95.00 mV
 Offset : 1.56 mm

1 gram SAR value : 0.452 W/kg
 10 gram SAR value : 0.251 W/kg
 Area Scan Peak SAR : 0.463 W/kg
 Zoom Scan Peak SAR : 0.860 W/kg

Plot 1#

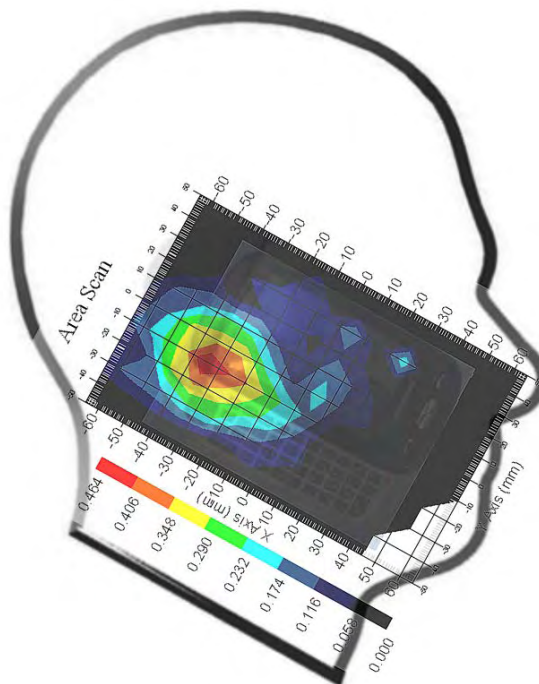

Test Laboratory: Bay Area Compliance Lab Corp. (Shenzhen)

Left Head Cheek-open keypad (835 MHz Middle Channel)

Measurement Data

Test mode : GSM
 Crest Factor : 8
 Scan Type : Complete
 Area Scan : 13x9x1 : Measurement x=10mm, y=10mm, z=4mm
 Zoom Scan : 7x7x7 : Measurement x=5mm, y=5mm, z=5mm
 Power Drift-Start : 0.454 W/kg
 Power Drift-Finish : 0.446 W/kg
 Power Drift (%) : -2.105

Tissue Data

Type : HEAD
 Frequency : 835.00 MHz
 Epsilon : 41.24 F/m
 Sigma : 0.91 S/m
 Density : 1000.00 kg/cu. m

Probe Data

Serial No. : 500-00283
 Frequency : 835.00 MHz
 Duty Cycle Factor : 8
 Conversion Factor : 6.5
 Probe Sensitivity : 1.20 1.20 1.20 $\mu\text{V}/(\text{V}/\text{m})^2$
 Compression Point : 95.00 mV
 Offset : 1.56 mm

1 gram SAR value : 0.458 W/kg
 10 gram SAR value : 0.226 W/kg
 Area Scan Peak SAR : 0.456 W/kg
 Zoom Scan Peak SAR : 0.821 W/kg

Plot 2#

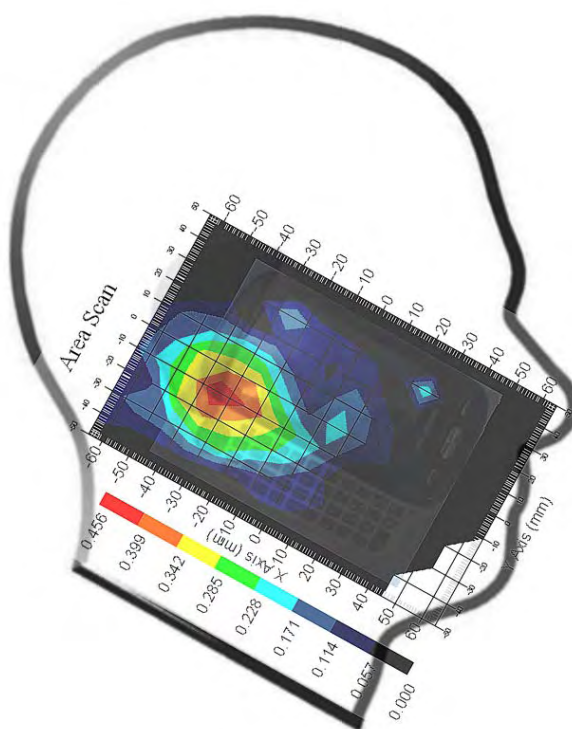

Test Laboratory: Bay Area Compliance Lab Corp. (Shenzhen)

Left Head Cheek-open keypad (835 MHz High Channel)

Measurement Data

Test mode : GSM
 Crest Factor : 8
 Scan Type : Complete
 Area Scan : 13x9x1 : Measurement x=10mm, y=10mm, z=4mm
 Zoom Scan : 7x7x7 : Measurement x=5mm, y=5mm, z=5mm
 Power Drift-Start : 0.510 W/kg
 Power Drift-Finish : 0.504 W/kg
 Power Drift (%) : -1.215

Tissue Data

Type : HEAD
 Frequency : 835.00 MHz
 Epsilon : 41.24 F/m
 Sigma : 0.91 S/m
 Density : 1000.00 kg/cu. m

Probe Data

Serial No. : 500-00283
 Frequency : 835.00 MHz
 Duty Cycle Factor : 8
 Conversion Factor : 6.5
 Probe Sensitivity : 1.20 1.20 1.20 $\mu\text{V}/(\text{V}/\text{m})^2$
 Compression Point : 95.00 mV
 Offset : 1.56 mm

1 gram SAR value : 0.471 W/kg
 10 gram SAR value : 0.235 W/kg
 Area Scan Peak SAR : 0.473 W/kg
 Zoom Scan Peak SAR : 0.892 W/kg

Plot 3#

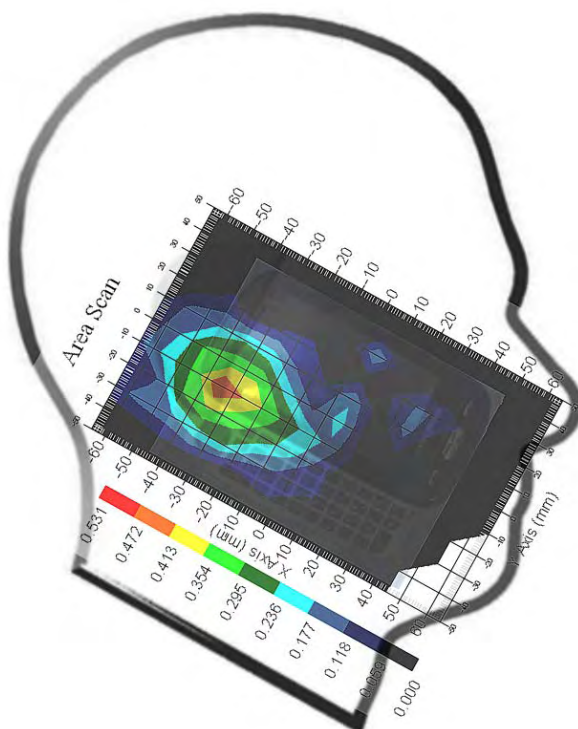

Test Laboratory: Bay Area Compliance Lab Corp. (Shenzhen)

Left Head Tilt-open keypad (835 MHz High Channel)

Measurement Data

Test mode : GSM
 Crest Factor : 8
 Scan Type : Complete
 Area Scan : 13x9x1 : Measurement x=10mm, y=10mm, z=4mm
 Zoom Scan : 7x7x7 : Measurement x=5mm, y=5mm, z=5mm
 Power Drift-Start : 0.350 W/kg
 Power Drift-Finish : 0.336 W/kg
 Power Drift (%) : -3.985

Tissue Data

Type : HEAD
 Frequency : 835.00 MHz
 Epsilon : 41.24 F/m
 Sigma : 0.91 S/m
 Density : 1000.00 kg/cu. m

Probe Data

Serial No. : 500-00283
 Frequency : 835.00 MHz
 Duty Cycle Factor : 8
 Conversion Factor : 6.5
 Probe Sensitivity : 1.20 1.20 1.20 $\mu\text{V}/(\text{V}/\text{m})^2$
 Compression Point : 95.00 mV
 Offset : 1.56 mm

1 gram SAR value : 0.258 W/kg
 10 gram SAR value : 0.120 W/kg
 Area Scan Peak SAR : 0.266 W/kg
 Zoom Scan Peak SAR : 0.560 W/kg

Plot 4#

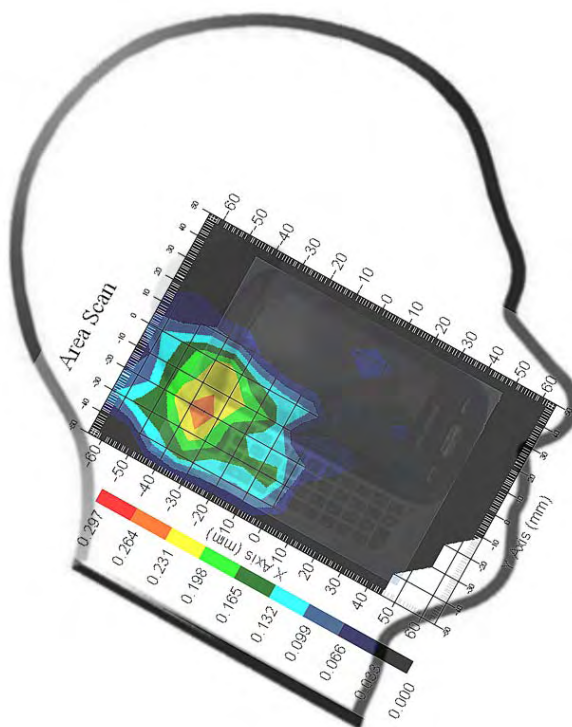

Test Laboratory: Bay Area Compliance Lab Corp. (Shenzhen)

Right Head Cheek-open keypad (835 MHz High Channel)

Measurement Data

Test mode : GSM
 Crest Factor : 8
 Scan Type : Complete
 Area Scan : 13x9x1 : Measurement x=10mm, y=10mm, z=4mm
 Zoom Scan : 7x7x7 : Measurement x=5mm, y=5mm, z=5mm
 Power Drift-Start : 0.500 W/kg
 Power Drift-Finish : 0.512 W/kg
 Power Drift (%) : 2.354

Tissue Data

Type : HEAD
 Frequency : 835.00 MHz
 Epsilon : 41.24 F/m
 Sigma : 0.91 S/m
 Density : 1000.00 kg/cu. m

Probe Data

Serial No. : 500-00283
 Frequency : 835.00 MHz
 Duty Cycle Factor : 8
 Conversion Factor : 6.5
 Probe Sensitivity : 1.20 1.20 1.20 $\mu\text{V}/(\text{V}/\text{m})^2$
 Compression Point : 95.00 mV
 Offset : 1.56 mm

1 gram SAR value : 0.462 W/kg
 10 gram SAR value : 0.221 W/kg
 Area Scan Peak SAR : 0.460 W/kg
 Zoom Scan Peak SAR : 0.821 W/kg

Plot 5#

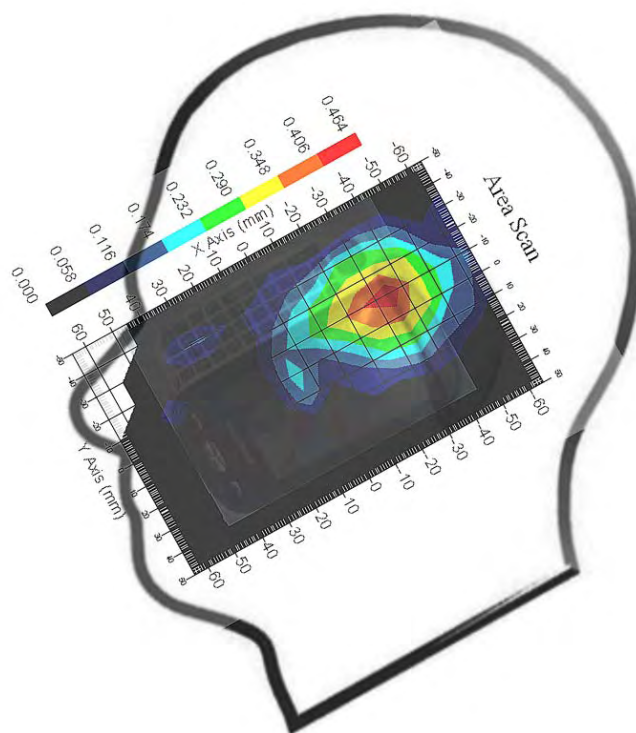

Test Laboratory: Bay Area Compliance Lab Corp. (Shenzhen)

Right Head Tilt-open keypad (835 MHz High Channel)

Measurement Data

Test mode : GSM
 Crest Factor : 8
 Scan Type : Complete
 Area Scan : 13x9x1 : Measurement x=10mm, y=10mm, z=4mm
 Zoom Scan : 7x7x7 : Measurement x=5mm, y=5mm, z=5mm
 Power Drift-Start : 0.401 W/kg
 Power Drift-Finish : 0.387 W/kg
 Power Drift (%) : -3.520

Tissue Data

Type : HEAD
 Frequency : 835.00 MHz
 Epsilon : 41.24 F/m
 Sigma : 0.91 S/m
 Density : 1000.00 kg/cu. m

Probe Data

Serial No. : 500-00283
 Frequency : 835.00 MHz
 Duty Cycle Factor : 8
 Conversion Factor : 6.5
 Probe Sensitivity : 1.20 1.20 1.20 $\mu\text{V}/(\text{V}/\text{m})^2$
 Compression Point : 95.00 mV
 Offset : 1.56 mm

1 gram SAR value : 0.255 W/kg
 10 gram SAR value : 0.119 W/kg
 Area Scan Peak SAR : 0.260 W/kg
 Zoom Scan Peak SAR : 0.523 W/kg

Plot 6#

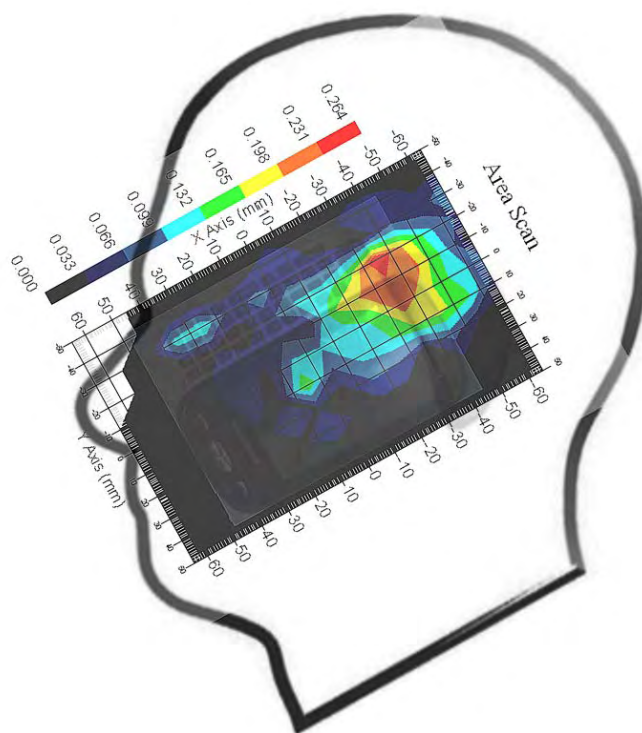

Test Laboratory: Bay Area Compliance Lab Corp. (Shenzhen)

Body worn back - open keypad (835 MHz High Channel)

Measurement Data

Test mode : GSM
 Crest Factor : 8
 Scan Type : Complete
 Area Scan : 9x13x1: Measurement x=10mm, y=10mm, z=4mm
 Zoom Scan : 7x7x7 : Measurement x=5mm, y=5mm, z=5mm
 Power Drift-Start : 0.182 W/kg
 Power Drift-Finish : 0.180 W/kg
 Power Drift (%) : -1.210

Tissue Data

Type : BODY
 Frequency : 835.00 MHz
 Epsilon : 55.50 F/m
 Sigma : 0.99 S/m
 Density : 1000.00 kg/cu. m

Probe Data

Serial No. : 500-00283
 Frequency : 835.00 MHz
 Duty Cycle Factor : 8
 Conversion Factor : 6.7
 Probe Sensitivity : 1.20 1.20 1.20 $\mu\text{V}/(\text{V}/\text{m})^2$
 Compression Point : 95.00 mV
 Offset : 1.56 mm

1 gram SAR value : 0.175 W/kg
 10 gram SAR value : 0.102 W/kg
 Area Scan Peak SAR : 0.184 W/kg
 Zoom Scan Peak SAR : 0.415 W/kg

Plot 7#

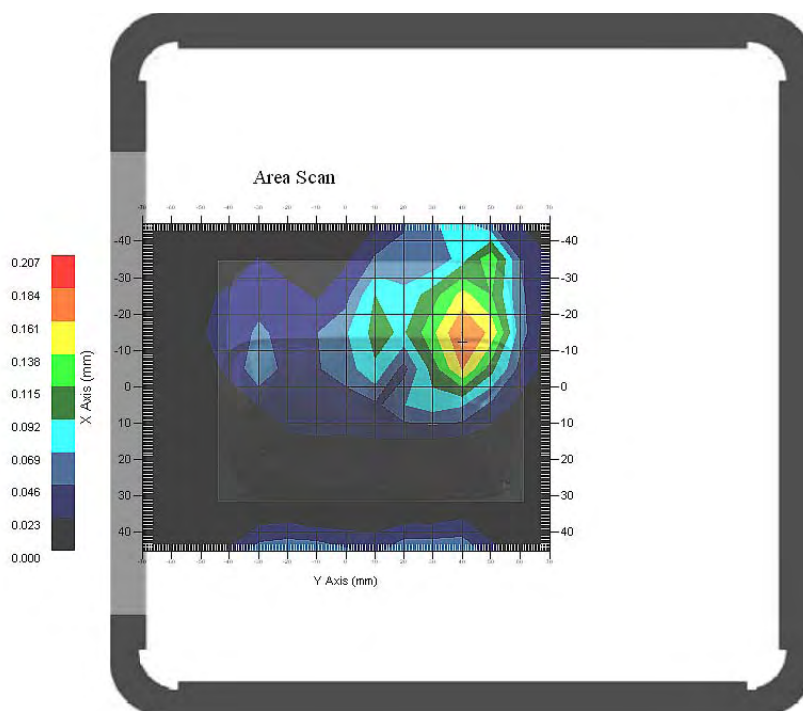

Test Laboratory: Bay Area Compliance Lab Corp. (Shenzhen)

Body worn back - open keypad (835 MHz Low Channel)

Measurement Data

Test mode : GPRS
 Crest Factor : 2
 Scan Type : Complete
 Area Scan : 9x13x1: Measurement x=10mm, y=10mm, z=4mm
 Zoom Scan : 7x7x7 : Measurement x=5mm, y=5mm, z=5mm
 Power Drift-Start : 0.109 W/kg
 Power Drift-Finish : 0.112 W/kg
 Power Drift (%) : 3.204

Tissue Data

Type : BODY
 Frequency : 835.00 MHz
 Epsilon : 55.50 F/m
 Sigma : 0.99 S/m
 Density : 1000.00 kg/cu. m

Probe Data

Serial No. : 500-00283
 Frequency : 835.00 MHz
 Duty Cycle Factor : 2
 Conversion Factor : 6.7
 Probe Sensitivity : 1.20 1.20 1.20 $\mu\text{V}/(\text{V}/\text{m})^2$
 Compression Point : 95.00 mV
 Offset : 1.56 mm

1 gram SAR value : 0.673 W/kg
 10 gram SAR value : 0.322 W/kg
 Area Scan Peak SAR : 0.709 W/kg
 Zoom Scan Peak SAR : 1.250 W/kg

Plot 8#

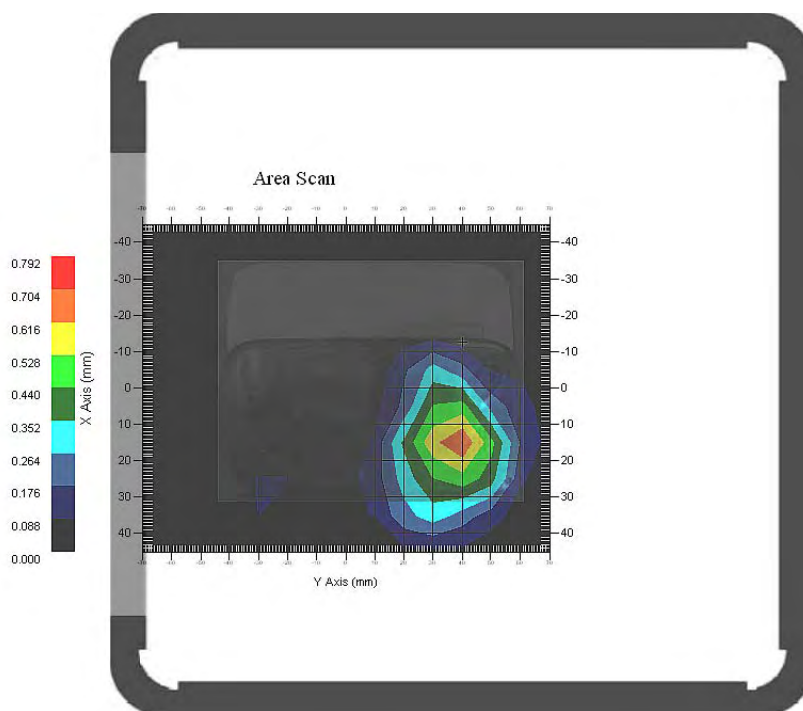

Test Laboratory: Bay Area Compliance Lab Corp. (Shenzhen)

Body worn back - open keypad (835 MHz Middle Channel)

Measurement Data

Test mode : GPRS
 Crest Factor : 2
 Scan Type : Complete
 Area Scan : 9x13x1: Measurement x=10mm, y=10mm, z=4mm
 Zoom Scan : 7x7x7 : Measurement x=5mm, y=5mm, z=5mm
 Power Drift-Start : 0.125 W/kg
 Power Drift-Finish : 0.128 W/kg
 Power Drift (%) : 2.513

Tissue Data

Type : BODY
 Frequency : 835.00 MHz
 Epsilon : 55.50 F/m
 Sigma : 0.99 S/m
 Density : 1000.00 kg/cu. m

Probe Data

Serial No. : 500-00283
 Frequency : 835.00 MHz
 Duty Cycle Factor : 2
 Conversion Factor : 6.7
 Probe Sensitivity : 1.20 1.20 1.20 $\mu\text{V}/(\text{V}/\text{m})^2$
 Compression Point : 95.00 mV
 Offset : 1.56 mm

1 gram SAR value : 0.682 W/kg
 10 gram SAR value : 0.348 W/kg
 Area Scan Peak SAR : 0.684 W/kg
 Zoom Scan Peak SAR : 1.235 W/kg

Plot 9#

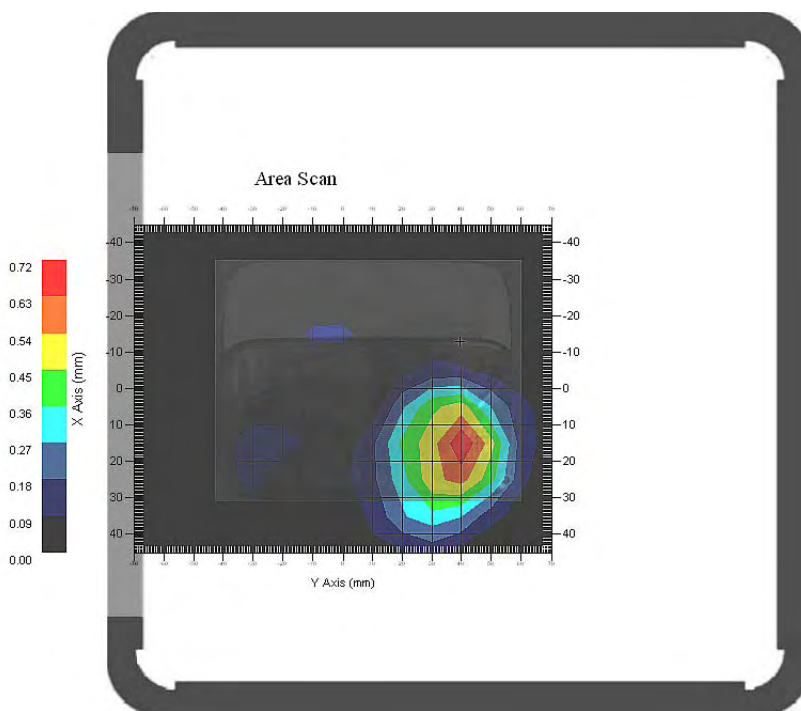

Test Laboratory: Bay Area Compliance Lab Corp. (Shenzhen)

Body worn back - open keypad (835 MHz High Channel)

Measurement Data

Test mode : GPRS
 Crest Factor : 2
 Scan Type : Complete
 Area Scan : 9x13x1: Measurement x=10mm, y=10mm, z=4mm
 Zoom Scan : 7x7x7 : Measurement x=5mm, y=5mm, z=5mm
 Power Drift-Start : 0.130 W/kg
 Power Drift-Finish : 0.126 W/kg
 Power Drift (%) : 3.158

Tissue Data

Type : BODY
 Frequency : 835.00 MHz
 Epsilon : 55.50 F/m
 Sigma : 0.99 S/m
 Density : 1000.00 kg/cu. m

Probe Data

Serial No. : 500-00283
 Frequency : 835.00 MHz
 Duty Cycle Factor : 2
 Conversion Factor : 6.7
 Probe Sensitivity : 1.20 1.20 1.20 $\mu\text{V}/(\text{V}/\text{m})^2$
 Compression Point : 95.00 mV
 Offset : 1.56 mm

1 gram SAR value : 0.692 W/kg
 10 gram SAR value : 0.353 W/kg
 Area Scan Peak SAR : 0.697 W/kg
 Zoom Scan Peak SAR : 1.321 W/kg

Plot 10#

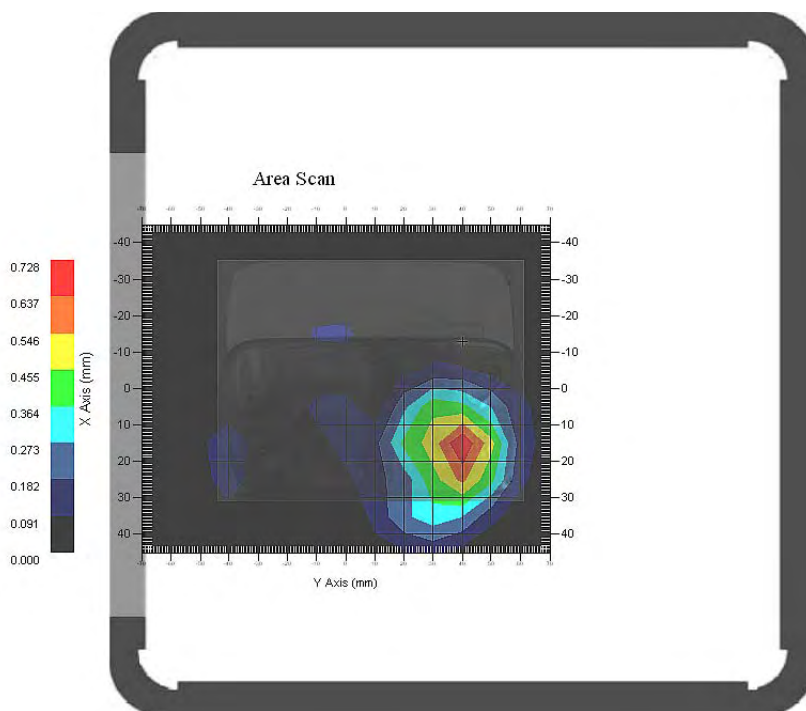

Test Laboratory: Bay Area Compliance Lab Corp. (Shenzhen)

Left Head Cheek-close keypad (835 MHz Low Channel)

Measurement Data

Test mode : GSM
 Crest Factor : 8
 Scan Type : Complete
 Area Scan : 13x9x1: Measurement x=10mm, y=10mm, z=4mm
 Zoom Scan : 7x7x7: Measurement x=5mm, y=5mm, z=5mm
 Power Drift-Start : 0.401 W/kg
 Power Drift-Finish : 0.406 W/kg
 Power Drift (%) : 1.320

Tissue Data

Type : HEAD
 Frequency : 835.00 MHz
 Epsilon : 41.24 F/m
 Sigma : 0.91 S/m
 Density : 1000.00 kg/cu. m

Probe Data

Serial No. : 500-00283
 Frequency : 835.00 MHz
 Duty Cycle Factor : 8
 Conversion Factor : 6.5
 Probe Sensitivity : 1.20 1.20 1.20 $\mu\text{V}/(\text{V}/\text{m})^2$
 Compression Point : 95.00 mV
 Offset : 1.56 mm

1 gram SAR value : 0.518 W/kg
 10 gram SAR value : 0.285 W/kg
 Area Scan Peak SAR : 0.543 W/kg
 Zoom Scan Peak SAR : 0.963 W/kg

Plot 11#

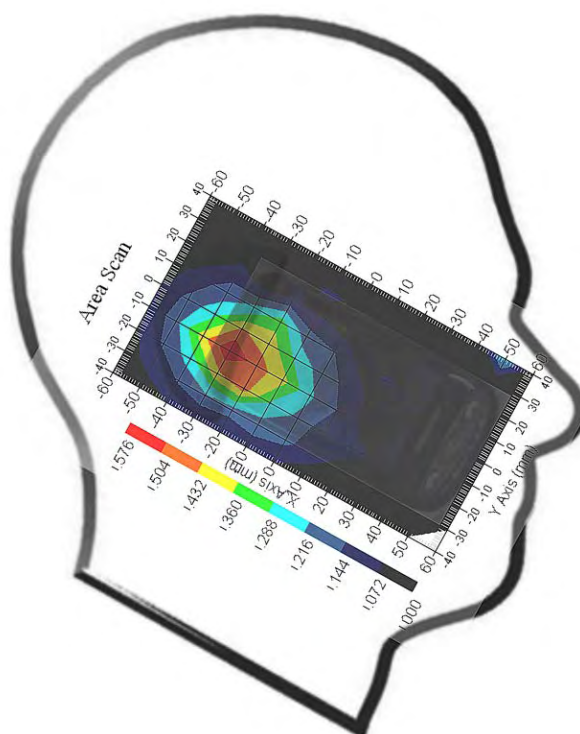

Test Laboratory: Bay Area Compliance Lab Corp. (Shenzhen)

Left Head Cheek-close keypad (835 MHz Middle Channel)

Measurement Data

Test mode : GSM
 Crest Factor : 8
 Scan Type : Complete
 Area Scan : 13x9x1 : Measurement x=10mm, y=10mm, z=4mm
 Zoom Scan : 7x7x7 : Measurement x=5mm, y=5mm, z=5mm
 Power Drift-Start : 0.460 W/kg
 Power Drift-Finish : 0.454 W/kg
 Power Drift (%) : -1.365

Tissue Data

Type : HEAD
 Frequency : 835.00 MHz
 Epsilon : 41.24 F/m
 Sigma : 0.91 S/m
 Density : 1000.00 kg/cu. m

Probe Data

Serial No. : 500-00283
 Frequency : 835.00 MHz
 Duty Cycle Factor : 8
 Conversion Factor : 6.5
 Probe Sensitivity : 1.20 1.20 1.20 $\mu\text{V}/(\text{V}/\text{m})^2$
 Compression Point : 95.00 mV
 Offset : 1.56 mm

1 gram SAR value : 0.525 W/kg
 10 gram SAR value : 0.256 W/kg
 Area Scan Peak SAR : 0.522 W/kg
 Zoom Scan Peak SAR : 1.008 W/kg

Plot 12#

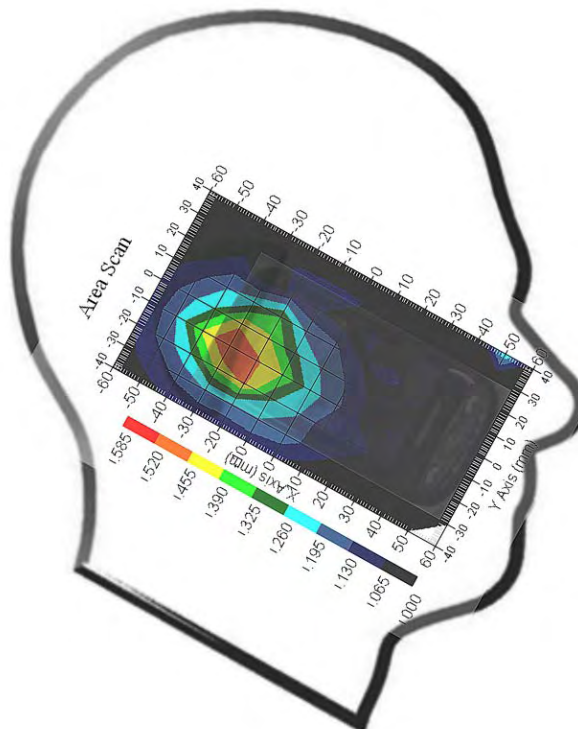

Test Laboratory: Bay Area Compliance Lab Corp. (Shenzhen)

Left Head Cheek-close keypad (835 MHz High Channel)

Measurement Data

Test mode : GSM
 Crest Factor : 8
 Scan Type : Complete
 Area Scan : 13x9x1 : Measurement x=10mm, y=10mm, z=4mm
 Zoom Scan : 7x7x7 : Measurement x=5mm, y=5mm, z=5mm
 Power Drift-Start : 0.501 W/kg
 Power Drift-Finish : 0.498 W/kg
 Power Drift (%) : -0.601

Tissue Data

Type : HEAD
 Frequency : 835.00 MHz
 Epsilon : 41.24 F/m
 Sigma : 0.91 S/m
 Density : 1000.00 kg/cu. m

Probe Data

Serial No. : 500-00283
 Frequency : 835.00 MHz
 Duty Cycle Factor : 8
 Conversion Factor : 6.5
 Probe Sensitivity : 1.20 1.20 1.20 $\mu\text{V}/(\text{V}/\text{m})^2$
 Compression Point : 95.00 mV
 Offset : 1.56 mm

1 gram SAR value : 0.541 W/kg
 10 gram SAR value : 0.261 W/kg
 Area Scan Peak SAR : 0.560 W/kg
 Zoom Scan Peak SAR : 1.120 W/kg

Plot 13#

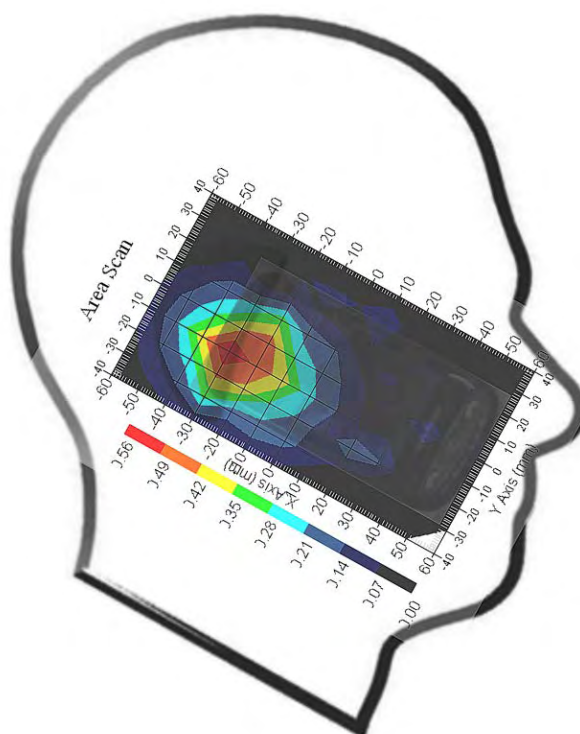

Test Laboratory: Bay Area Compliance Lab Corp. (Shenzhen)

Left Head Tilt-close keypad (835 MHz High Channel)

Measurement Data

Test mode : GSM
 Crest Factor : 8
 Scan Type : Complete
 Area Scan : 13x9x1 : Measurement x=10mm, y=10mm, z=4mm
 Zoom Scan : 7x7x7 : Measurement x=5mm, y=5mm, z=5mm
 Power Drift-Start : 0.340 W/kg
 Power Drift-Finish : 0.342 W/kg
 Power Drift (%) : 0.698

Tissue Data

Type : HEAD
 Frequency : 835.00 MHz
 Epsilon : 41.24 F/m
 Sigma : 0.91 S/m
 Density : 1000.00 kg/cu. m

Probe Data

Serial No. : 500-00283
 Frequency : 835.00 MHz
 Duty Cycle Factor : 8
 Conversion Factor : 6.5
 Probe Sensitivity : 1.20 1.20 1.20 $\mu\text{V}/(\text{V}/\text{m})^2$
 Compression Point : 95.00 mV
 Offset : 1.56 mm

1 gram SAR value : 0.352 W/kg
 10 gram SAR value : 0.168 W/kg
 Area Scan Peak SAR : 0.345 W/kg
 Zoom Scan Peak SAR : 0.584 W/kg

Plot 14#

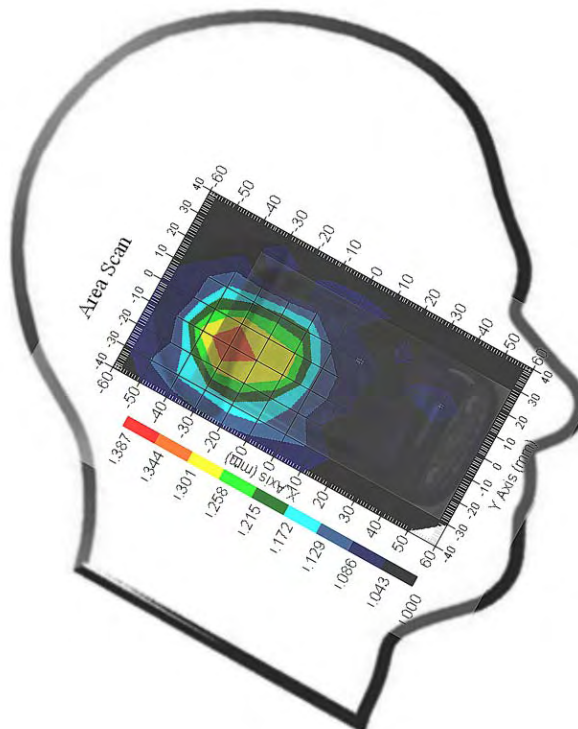

Test Laboratory: Bay Area Compliance Lab Corp. (Shenzhen)

Right Head Cheek-close keypad (835 MHz High Channel)

Measurement Data

Test mode : GSM
 Crest Factor : 8
 Scan Type : Complete
 Area Scan : 13x9x1 : Measurement x=10mm, y=10mm, z=4mm
 Zoom Scan : 7x7x7 : Measurement x=5mm, y=5mm, z=5mm
 Power Drift-Start : 0.566 W/kg
 Power Drift-Finish : 0.577 W/kg
 Power Drift (%) : 2.051

Tissue Data

Type : HEAD
 Frequency : 835.00 MHz
 Epsilon : 41.24 F/m
 Sigma : 0.91 S/m
 Density : 1000.00 kg/cu. m

Probe Data

Serial No. : 500-00283
 Frequency : 835.00 MHz
 Duty Cycle Factor : 8
 Conversion Factor : 6.5
 Probe Sensitivity : 1.20 1.20 1.20 $\mu\text{V}/(\text{V}/\text{m})^2$
 Compression Point : 95.00 mV
 Offset : 1.56 mm

1 gram SAR value : 0.536 W/kg
 10 gram SAR value : 0.222 W/kg
 Area Scan Peak SAR : 0.562 W/kg
 Zoom Scan Peak SAR : 0.956 W/kg

Plot 15#

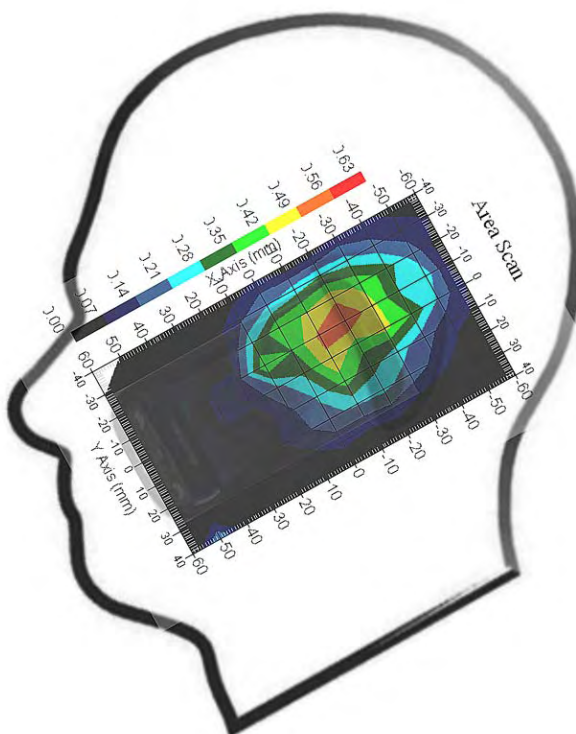

Test Laboratory: Bay Area Compliance Lab Corp. (Shenzhen)

Right Head Tilt-close keypad (835 MHz High Channel)

Measurement Data

Test mode : GSM
 Crest Factor : 8
 Scan Type : Complete
 Area Scan : 13x9x1 : Measurement x=10mm, y=10mm, z=4mm
 Zoom Scan : 7x7x7 : Measurement x=5mm, y=5mm, z=5mm
 Power Drift-Start : 0.479 W/kg
 Power Drift-Finish : 0.481 W/kg
 Power Drift (%) : 0.505

Tissue Data

Type : HEAD
 Frequency : 835.00 MHz
 Epsilon : 41.24 F/m
 Sigma : 0.91 S/m
 Density : 1000.00 kg/cu. m

Probe Data

Serial No. : 500-00283
 Frequency : 835.00 MHz
 Duty Cycle Factor : 8
 Conversion Factor : 6.5
 Probe Sensitivity : 1.20 1.20 1.20 $\mu\text{V}/(\text{V}/\text{m})^2$
 Compression Point : 95.00 mV
 Offset : 1.56 mm

1 gram SAR value : 0.341 W/kg
 10 gram SAR value : 0.162 W/kg
 Area Scan Peak SAR : 0.320 W/kg
 Zoom Scan Peak SAR : 0.548 W/kg

Plot 16#

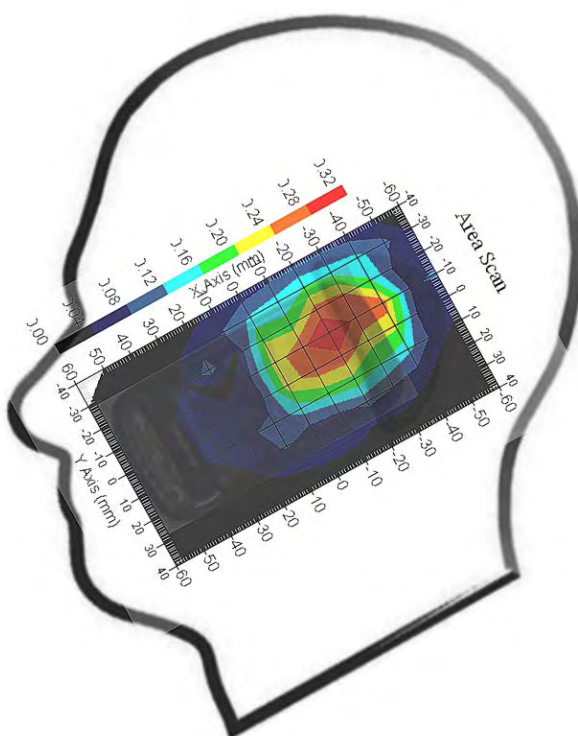

Test Laboratory: Bay Area Compliance Lab Corp. (Shenzhen)

Body- worn Back – close keypad (835 MHz High Channel)

Measurement Data

Test mode : GSM
 Crest Factor : 8
 Scan Type : Complete
 Area Scan : 9x13x1: Measurement x=10mm, y=10mm, z=4mm
 Zoom Scan : 7x7x7 : Measurement x=5mm, y=5mm, z=5mm
 Power Drift-Start : 0.200 W/kg
 Power Drift-Finish : 0.197 W/kg
 Power Drift (%) : -1.335

Tissue Data

Type : BODY
 Frequency : 835.00 MHz
 Epsilon : 55.50 F/m
 Sigma : 0.99 S/m
 Density : 1000.00 kg/cu. m

Probe Data

Serial No. : 500-00283
 Frequency : 835.00 MHz
 Duty Cycle Factor : 8
 Conversion Factor : 6.7
 Probe Sensitivity : 1.20 1.20 1.20 $\mu\text{V}/(\text{V}/\text{m})^2$
 Compression Point : 95.00 mV
 Offset : 1.56 mm

1 gram SAR value : 0.206 W/kg
 10 gram SAR value : 0.106 W/kg
 Area Scan Peak SAR : 0.212 W/kg
 Zoom Scan Peak SAR : 0.450 W/kg

Plot 17#

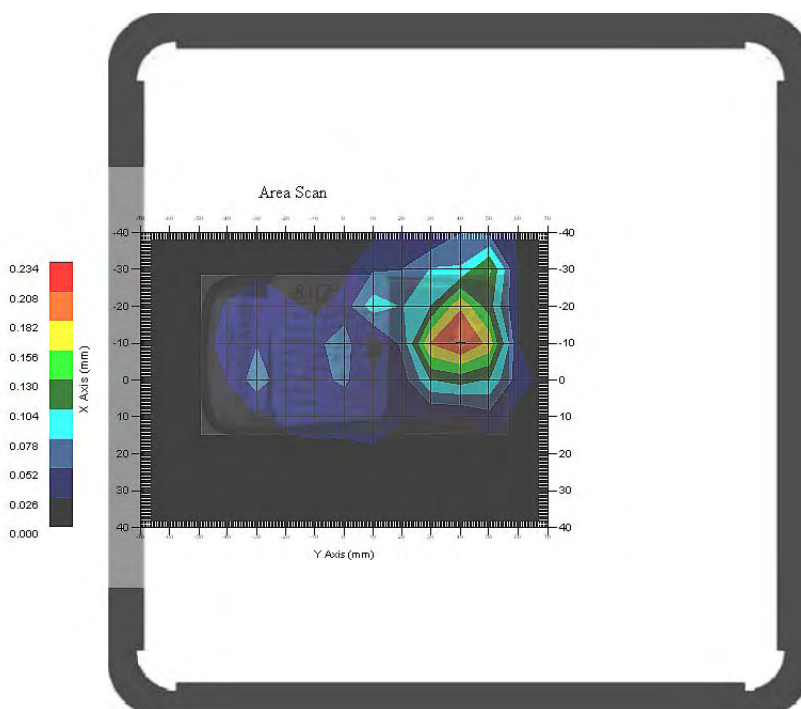

Test Laboratory: Bay Area Compliance Lab Corp. (Shenzhen)

Body- worn Back – close keypad (835 MHz Low Channel)

Measurement Data

Test mode : GPRS
 Crest Factor : 2
 Scan Type : Complete
 Area Scan : 9x13x1: Measurement x=10mm, y=10mm, z=4mm
 Zoom Scan : 7x7x7 : Measurement x=5mm, y=5mm, z=5mm
 Power Drift-Start : 0.114 W/kg
 Power Drift-Finish : 0.120 W/kg
 Power Drift (%) : 4.517

Tissue Data

Type : BODY
 Frequency : 835.00 MHz
 Epsilon : 55.50 F/m
 Sigma : 0.99 S/m
 Density : 1000.00 kg/cu. m

Probe Data

Serial No. : 500-00283
 Frequency : 835.00 MHz
 Duty Cycle Factor : 2
 Conversion Factor : 6.7
 Probe Sensitivity : 1.20 1.20 1.20 $\mu\text{V}/(\text{V}/\text{m})^2$
 Compression Point : 95.00 mV
 Offset : 1.56 mm

1 gram SAR value : 0.823 W/kg
 10 gram SAR value : 0.375 W/kg
 Area Scan Peak SAR : 0.884 W/kg
 Zoom Scan Peak SAR : 1.581 W/kg

Plot 18#

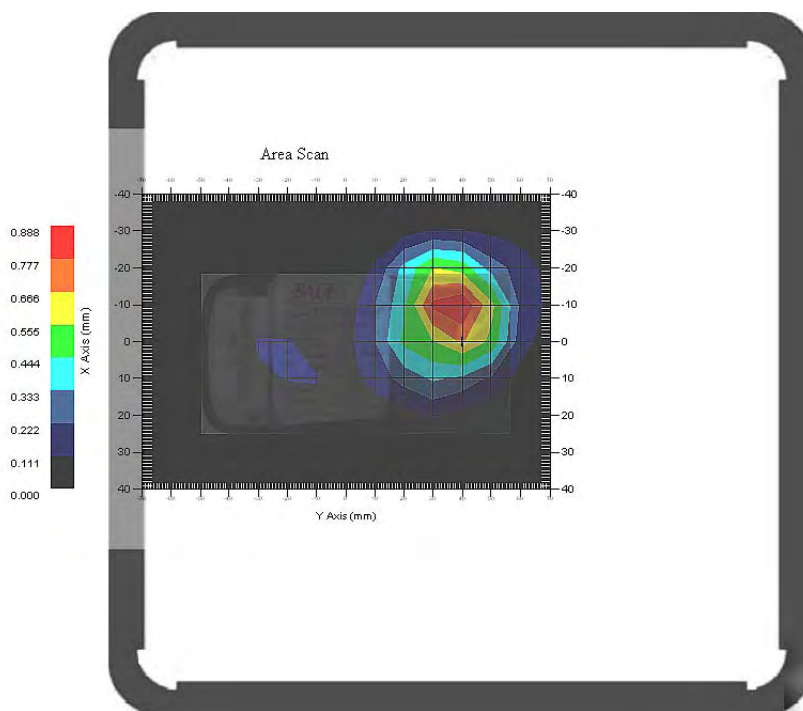

Test Laboratory: Bay Area Compliance Lab Corp. (Shenzhen)

Body- worn Back – close keypad (835 MHz Middle Channel)

Measurement Data

Test mode : GPRS
 Crest Factor : 2
 Scan Type : Complete
 Area Scan : 9x13x1: Measurement x=10mm, y=10mm, z=4mm
 Zoom Scan : 7x7x7 : Measurement x=5mm, y=5mm, z=5mm
 Power Drift-Start : 0.045 W/kg
 Power Drift-Finish : 0.046 W/kg
 Power Drift (%) : 3.820

Tissue Data

Type : BODY
 Frequency : 835.00 MHz
 Epsilon : 55.50 F/m
 Sigma : 0.99 S/m
 Density : 1000.00 kg/cu. m

Probe Data

Serial No. : 500-00283
 Frequency : 835.00 MHz
 Duty Cycle Factor : 2
 Conversion Factor : 6.7
 Probe Sensitivity : 1.20 1.20 1.20 $\mu\text{V}/(\text{V}/\text{m})^2$
 Compression Point : 95.00 mV
 Offset : 1.56 mm

1 gram SAR value : 0.757 W/kg
 10 gram SAR value : 0.359 W/kg
 Area Scan Peak SAR : 0.704 W/kg
 Zoom Scan Peak SAR : 1.231 W/kg

Plot 19#

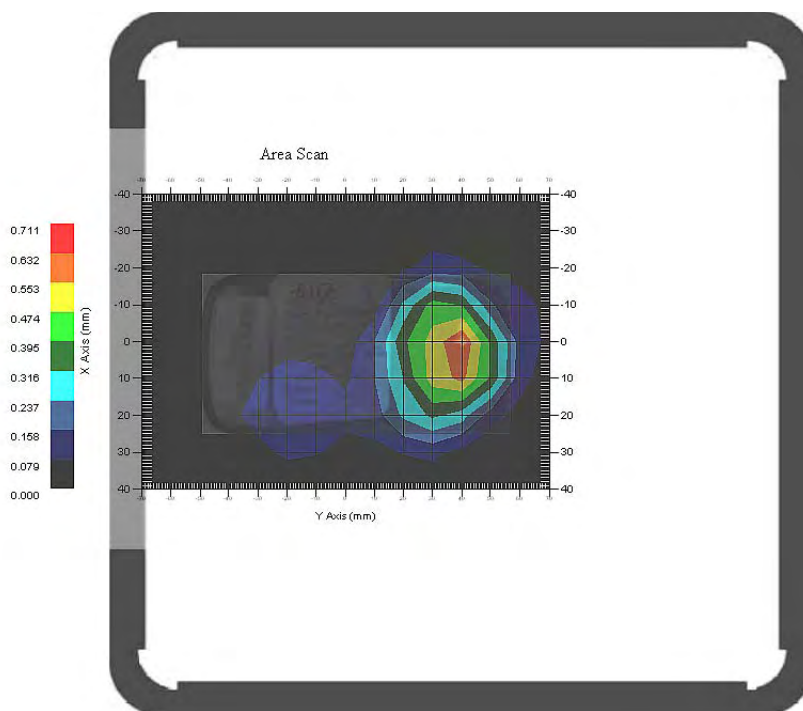

Test Laboratory: Bay Area Compliance Lab Corp. (Shenzhen)

Body- worn Back – close keypad (835 MHz High Channel)

Measurement Data

Test mode : GPRS
 Crest Factor : 2
 Scan Type : Complete
 Area Scan : 9x13x1: Measurement x=10mm, y=10mm, z=4mm
 Zoom Scan : 7x7x7 : Measurement x=5mm, y=5mm, z=5mm
 Power Drift-Start : 0.042 W/kg
 Power Drift-Finish : 0.041 W/kg
 Power Drift (%) : -2.554

Tissue Data

Type : BODY
 Frequency : 835.00 MHz
 Epsilon : 55.50 F/m
 Sigma : 0.99 S/m
 Density : 1000.00 kg/cu. m

Probe Data

Serial No. : 500-00283
 Frequency : 835.00 MHz
 Duty Cycle Factor : 2
 Conversion Factor : 6.7
 Probe Sensitivity : 1.20 1.20 1.20 $\mu\text{V}/(\text{V}/\text{m})^2$
 Compression Point : 95.00 mV
 Offset : 1.56 mm

1 gram SAR value : 0.804 W/kg
 10 gram SAR value : 0.388 W/kg
 Area Scan Peak SAR : 0.789 W/kg
 Zoom Scan Peak SAR : 1.311 W/kg

Plot 20#

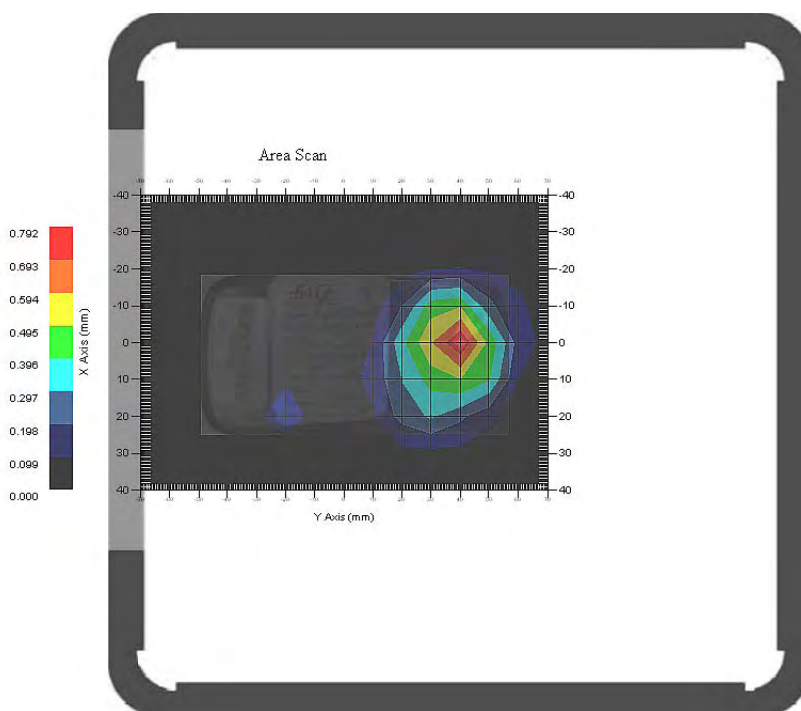

Test Laboratory: Bay Area Compliance Lab Corp. (Shenzhen)

Left Head Cheek-open keypad (1900 MHz High Channel)

Measurement Data

Test mode : GSM
 Crest Factor : 8
 Scan Type : Complete
 Area Scan : 13x9x1 : Measurement x=10mm, y=10mm, z=4mm
 Zoom Scan : 7x7x7 : Measurement x=5mm, y=5mm, z=5mm
 Power Drift-Start : 0.075 W/kg
 Power Drift-Finish : 0.077 W/kg
 Power Drift (%) : 2.986

Tissue Data

Type : HEAD
 Frequency : 1900.00 MHz
 Epsilon : 40.11 F/m
 Sigma : 1.44 S/m
 Density : 1000.00 kg/cu. m

Probe Data

Serial No. : 500-00283
 Frequency : 1900.00 MHz
 Duty Cycle Factor : 8
 Conversion Factor : 5.25
 Probe Sensitivity : 1.20 1.20 1.20 $\mu\text{V}/(\text{V}/\text{m})^2$
 Compression Point : 95.00 mV
 Offset : 1.56 mm

1 gram SAR value : 0.345 W/kg
 10 gram SAR value : 0.185 W/kg
 Area Scan Peak SAR : 0.380 W/kg
 Zoom Scan Peak SAR : 0.400 W/kg

Plot 21#

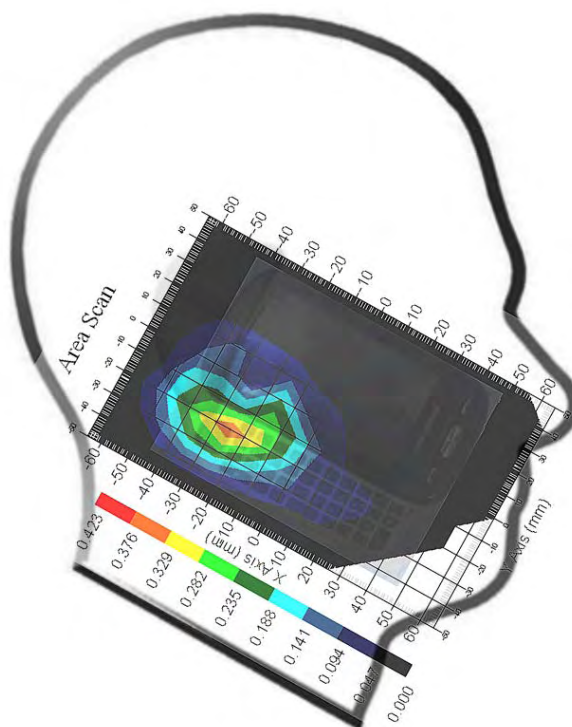

Test Laboratory: Bay Area Compliance Lab Corp. (Shenzhen)

Left Head Tilt-open keypad (1900 MHz High Channel)

Measurement Data

Test mode : GSM
 Crest Factor : 8
 Scan Type : Complete
 Area Scan : 13x9x1 : Measurement x=10mm, y=10mm, z=4mm
 Zoom Scan : 7x7x7 : Measurement x=5mm, y=5mm, z=5mm
 Power Drift-Start : 0.112 W/kg
 Power Drift-Finish : 0.113 W/kg
 Power Drift (%) : -1.146

Tissue Data

Type : HEAD
 Frequency : 1900.00 MHz
 Epsilon : 40.11 F/m
 Sigma : 1.44 S/m
 Density : 1000.00 kg/cu. m

Probe Data

Serial No. : 500-00283
 Frequency : 1900.00 MHz
 Duty Cycle Factor : 8
 Conversion Factor : 5.25
 Probe Sensitivity : 1.20 1.20 1.20 $\mu\text{V}/(\text{V}/\text{m})^2$
 Compression Point : 95.00 mV
 Offset : 1.56 mm

1 gram SAR value : 0.255 W/kg
 10 gram SAR value : 0.126 W/kg
 Area Scan Peak SAR : 0.310 W/kg
 Zoom Scan Peak SAR : 0.511 W/kg

Plot 22#

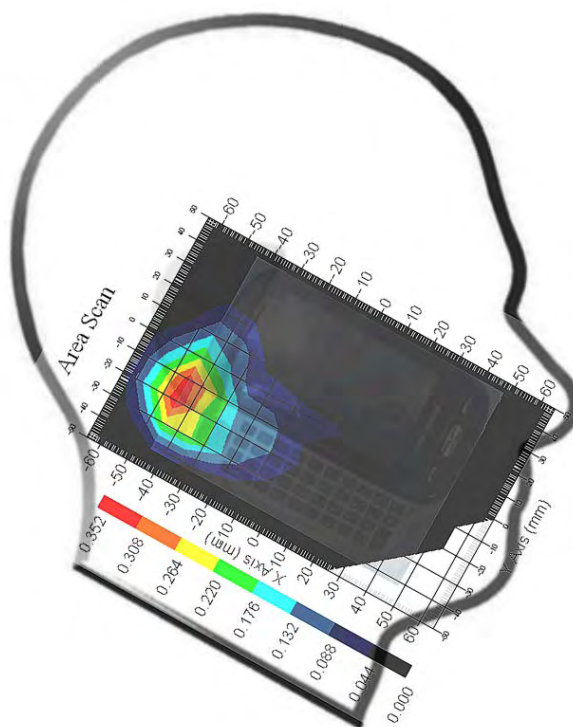

Test Laboratory: Bay Area Compliance Lab Corp. (Shenzhen)

Right Head Cheek-open keypad (1900 MHz Low Channel)

Measurement Data

Test mode : GSM
 Crest Factor : 8
 Scan Type : Complete
 Area Scan : 13x9x1 : Measurement x=10mm, y=10mm, z=4mm
 Zoom Scan : 7x7x7 : Measurement x=5mm, y=5mm, z=5mm
 Power Drift-Start : 0.080 W/kg
 Power Drift-Finish : 0.082 W/kg
 Power Drift (%) : 2.018

Tissue Data

Type : HEAD
 Frequency : 1900.00 MHz
 Epsilon : 40.11 F/m
 Sigma : 1.44 S/m
 Density : 1000.00 kg/cu. m

Probe Data

Serial No. : 500-00283
 Frequency : 1900.00 MHz
 Duty Cycle Factor : 8
 Conversion Factor : 5.25
 Probe Sensitivity : 1.20 1.20 1.20 $\mu\text{V}/(\text{V}/\text{m})^2$
 Compression Point : 95.00 mV
 Offset : 1.56 mm

1 gram SAR value : 0.354 W/kg
 10 gram SAR value : 0.183 W/kg
 Area Scan Peak SAR : 0.380 W/kg
 Zoom Scan Peak SAR : 0.590 W/kg

Plot 23#

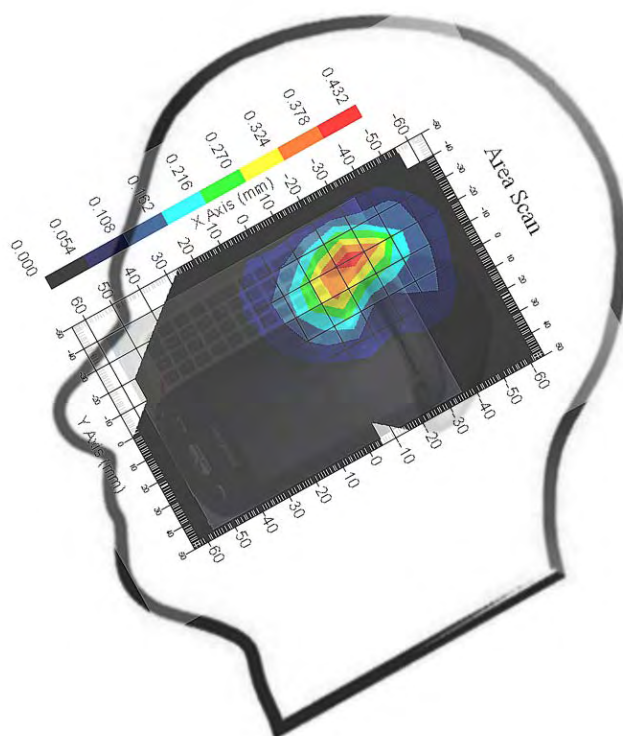

Test Laboratory: Bay Area Compliance Lab Corp. (Shenzhen)

Right Head Cheek-open keypad (1900 MHz Middle Channel)

Measurement Data

Test mode : GSM
 Crest Factor : 8
 Scan Type : Complete
 Area Scan : 13x9x1 : Measurement x=10mm, y=10mm, z=4mm
 Zoom Scan : 7x7x7 : Measurement x=5mm, y=5mm, z=5mm
 Power Drift-Start : 0.079 W/kg
 Power Drift-Finish : 0.080 W/kg
 Power Drift (%) : 1.700

Tissue Data

Type : HEAD
 Frequency : 1900.00 MHz
 Epsilon : 40.11 F/m
 Sigma : 1.44 S/m
 Density : 1000.00 kg/cu. m

Probe Data

Serial No. : 500-00283
 Frequency : 1900.00 MHz
 Duty Cycle Factor : 8
 Conversion Factor : 5.25
 Probe Sensitivity : 1.20 1.20 1.20 $\mu\text{V}/(\text{V}/\text{m})^2$
 Compression Point : 95.00 mV
 Offset : 1.56 mm

1 gram SAR value : 0.355 W/kg
 10 gram SAR value : 0.179 W/kg
 Area Scan Peak SAR : 0.333 W/kg
 Zoom Scan Peak SAR : 0.600 W/kg

Plot 24#

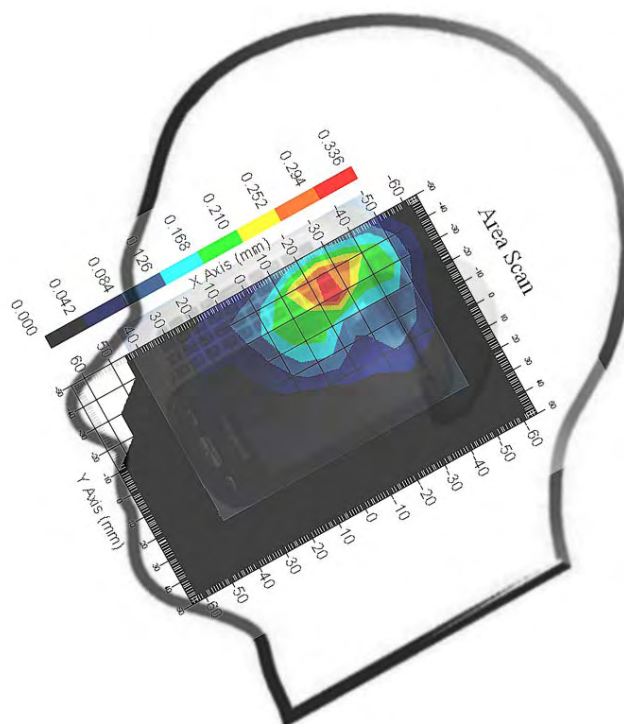

Test Laboratory: Bay Area Compliance Lab Corp. (Shenzhen)

Right Head Cheek-open keypad(1900 MHz High Channel)

Measurement Data

Test mode : GSM
 Crest Factor : 8
 Scan Type : Complete
 Area Scan : 13x9x1 : Measurement x=10mm, y=10mm, z=4mm
 Zoom Scan : 7x7x7 : Measurement x=5mm, y=5mm, z=5mm
 Power Drift-Start : 0.069 W/kg
 Power Drift-Finish : 0.069 W/kg
 Power Drift (%) : 0.786

Tissue Data

Type : HEAD
 Frequency : 1900.00 MHz
 Epsilon : 40.11 F/m
 Sigma : 1.44 S/m
 Density : 1000.00 kg/cu. m

Probe Data

Serial No. : 500-00283
 Frequency : 1900.00 MHz
 Duty Cycle Factor : 8
 Conversion Factor : 5.25
 Probe Sensitivity : 1.20 1.20 1.20 $\mu\text{V}/(\text{V}/\text{m})^2$
 Compression Point : 95.00 mV
 Offset : 1.56 mm

1 gram SAR value : 0.365 W/kg
 10 gram SAR value : 0.178 W/kg
 Area Scan Peak SAR : 0.368 W/kg
 Zoom Scan Peak SAR : 0.570 W/kg

Plot 25#

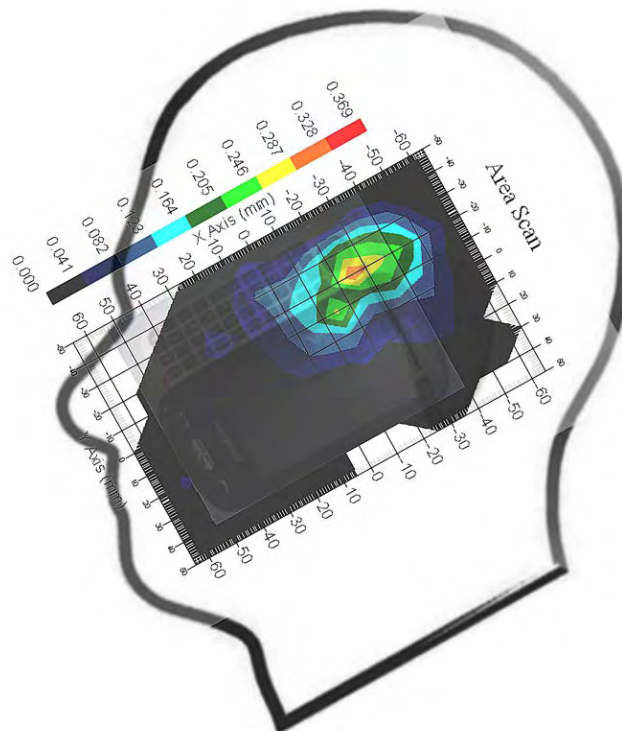

Test Laboratory: Bay Area Compliance Lab Corp. (Shenzhen)

Right Head Tilt-open keypad (1900 MHz High Channel)

Measurement Data

Test mode : GSM
 Crest Factor : 8
 Scan Type : Complete
 Area Scan : 13x9x1 : Measurement x=10mm, y=10mm, z=4mm
 Zoom Scan : 7x7x7 : Measurement x=5mm, y=5mm, z=5mm
 Power Drift-Start : 0.075 W/kg
 Power Drift-Finish : 0.074 W/kg
 Power Drift (%) : -1.936

Tissue Data

Type : HEAD
 Frequency : 1900.00 MHz
 Epsilon : 40.11 F/m
 Sigma : 1.44 S/m
 Density : 1000.00 kg/cu. m

Probe Data

Serial No. : 500-00283
 Frequency : 1900.00 MHz
 Duty Cycle Factor : 8
 Conversion Factor : 5.25
 Probe Sensitivity : 1.20 1.20 1.20 $\mu\text{V}/(\text{V}/\text{m})^2$
 Compression Point : 95.00 mV
 Offset : 1.56 mm

1 gram SAR value : 0.273 W/kg
 10 gram SAR value : 0.162 W/kg
 Area Scan Peak SAR : 0.380 W/kg
 Zoom Scan Peak SAR : 0.580 W/kg

Plot 26#

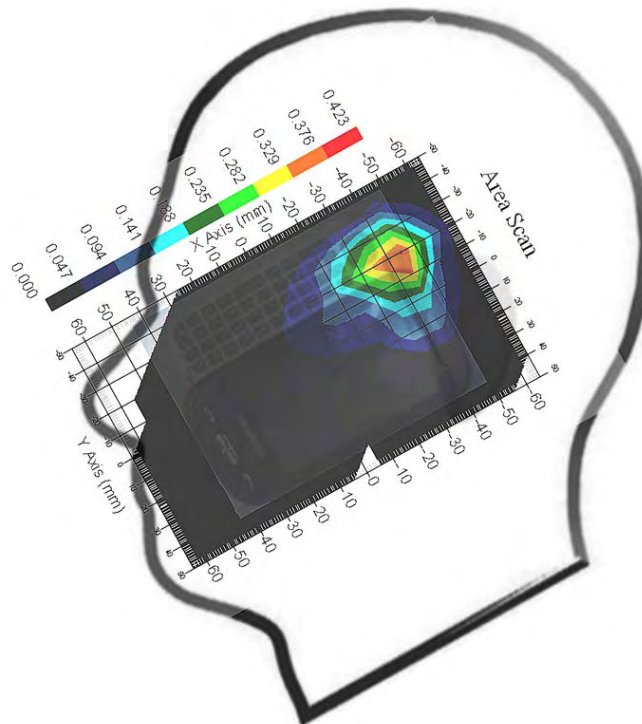

Test Laboratory: Bay Area Compliance Lab Corp. (Shenzhen)

Body- Worn back – open keypad (1900 MHz High Channel)

Measurement Data

Test mode : GSM
 Crest Factor : 8
 Scan Type : Complete
 Area Scan : 9x13x1 : Measurement x=10mm, y=10mm, z=4mm
 Zoom Scan : 7x7x7 : Measurement x=5mm, y=5mm, z=5mm
 Power Drift-Start : 0.184 W/kg
 Power Drift-Finish : 0.180 W/kg
 Power Drift (%) : -2.028

Tissue Data

Type : BODY
 Frequency : 1900.00 MHz
 Epsilon : 54.18 F/m
 Sigma : 1.48 S/m
 Density : 1000.00 kg/cu. m

Probe Data

Serial No. : 500-00283
 Frequency : 1900.00 MHz
 Duty Cycle Factor : 8
 Conversion Factor : 5.15
 Probe Sensitivity : 1.20 1.20 1.20 $\mu\text{V}/(\text{V}/\text{m})^2$
 Compression Point : 95.00 mV
 Offset : 1.56 mm

1 gram SAR value : 0.142 W/kg
 10 gram SAR value : 0.085 W/kg
 Area Scan Peak SAR : 0.145 W/kg
 Zoom Scan Peak SAR : 0.384 W/kg

Plot 27#

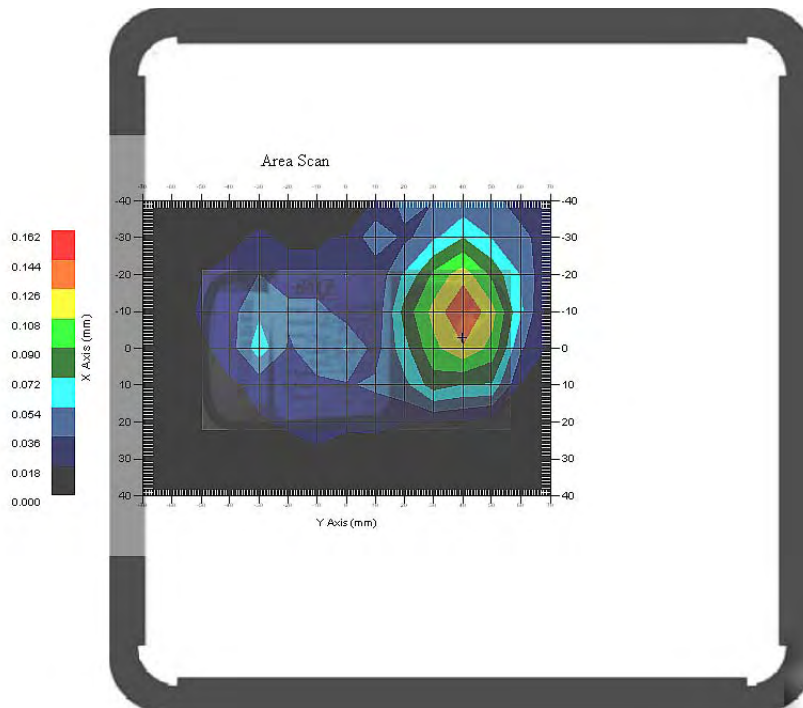

Test Laboratory: Bay Area Compliance Lab Corp. (Shenzhen)

Body- Worn back – open keypad (1900 MHz Low Channel)

Measurement Data

Test mode : GPRS
 Crest Factor : 2
 Scan Type : Complete
 Area Scan : 9x13x1 : Measurement x=10mm, y=10mm, z=4mm
 Zoom Scan : 7x7x7 : Measurement x=5mm, y=5mm, z=5mm
 Power Drift-Start : 0.221 W/kg
 Power Drift-Finish : 0.217 W/kg
 Power Drift (%) : -2.088

Tissue Data

Type : BODY
 Frequency : 1900.00 MHz
 Epsilon : 54.18 F/m
 Sigma : 1.48 S/m
 Density : 1000.00 kg/cu. m

Probe Data

Serial No. : 500-00283
 Frequency : 1900.00 MHz
 Duty Cycle Factor : 2
 Conversion Factor : 5.15
 Probe Sensitivity : 1.20 1.20 1.20 $\mu\text{V}/(\text{V}/\text{m})^2$
 Compression Point : 95.00 mV
 Offset : 1.56 mm

1 gram SAR value : 0.548 W/kg
 10 gram SAR value : 0.266 W/kg
 Area Scan Peak SAR : 0.546 W/kg
 Zoom Scan Peak SAR : 0.885 W/kg

Plot 28#

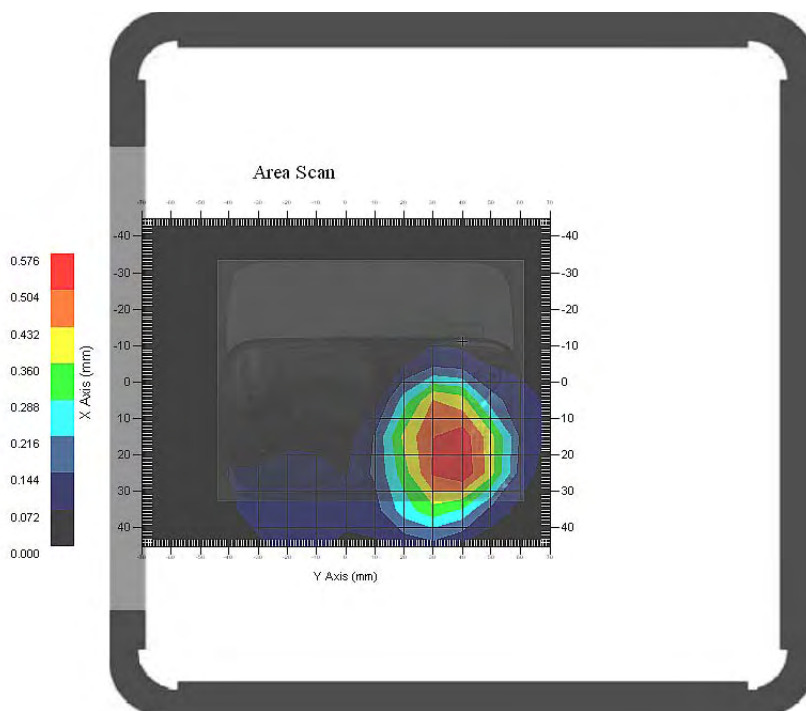

Test Laboratory: Bay Area Compliance Lab Corp. (Shenzhen)

Body- Worn back – open keypad (1900 MHz Middle Channel)

Measurement Data

Test mode : GPRS
 Crest Factor : 2
 Scan Type : Complete
 Area Scan : 9x13x1 : Measurement x=10mm, y=10mm, z=4mm
 Zoom Scan : 7x7x7 : Measurement x=5mm, y=5mm, z=5mm
 Power Drift-Start : 0.235 W/kg
 Power Drift-Finish : 0.230 W/kg
 Power Drift (%) : -2.721

Tissue Data

Type : BODY
 Frequency : 1900.00 MHz
 Epsilon : 54.18 F/m
 Sigma : 1.48 S/m
 Density : 1000.00 kg/cu. m

Probe Data

Serial No. : 500-00283
 Frequency : 1900.00 MHz
 Duty Cycle Factor : 2
 Conversion Factor : 5.15
 Probe Sensitivity : 1.20 1.20 1.20 $\mu\text{V}/(\text{V/m})^2$
 Compression Point : 95.00 mV
 Offset : 1.56 mm

1 gram SAR value : 0.565 W/kg
 10 gram SAR value : 0.282 W/kg
 Area Scan Peak SAR : 0.577 W/kg
 Zoom Scan Peak SAR : 0.894 W/kg

Plot 29#

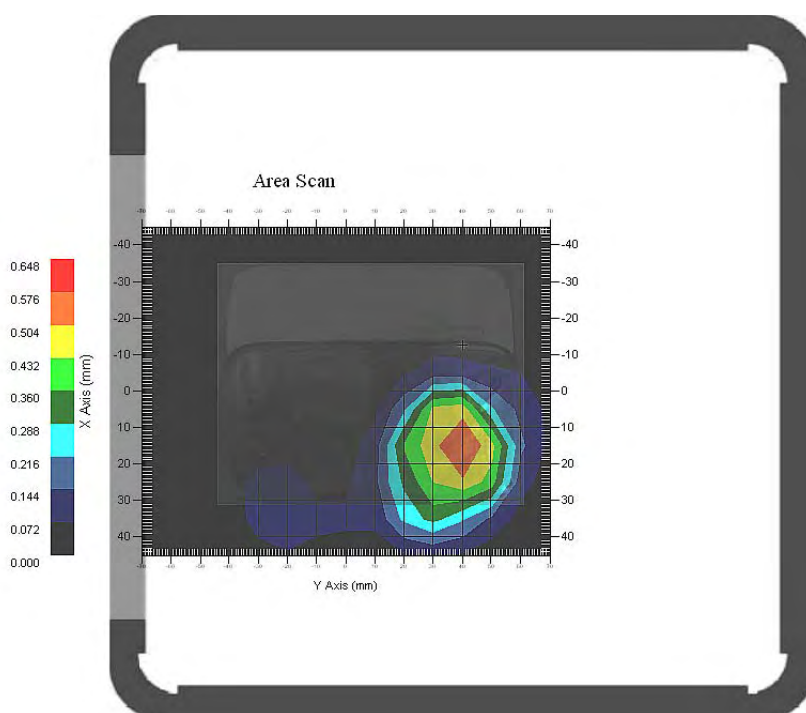

Test Laboratory: Bay Area Compliance Lab Corp. (Shenzhen)

Body- Worn back – open keypad (1900 MHz High Channel)

Measurement Data

Test mode : GPRS
 Crest Factor : 2
 Scan Type : Complete
 Area Scan : 9x13x1 : Measurement x=10mm, y=10mm, z=4mm
 Zoom Scan : 7x7x7 : Measurement x=5mm, y=5mm, z=5mm
 Power Drift-Start : 0.240 W/kg
 Power Drift-Finish : 0.233 W/kg
 Power Drift (%) : -3.010

Tissue Data

Type : BODY
 Frequency : 1900.00 MHz
 Epsilon : 54.18 F/m
 Sigma : 1.48 S/m
 Density : 1000.00 kg/cu. m

Probe Data

Serial No. : 500-00283
 Frequency : 1900.00 MHz
 Duty Cycle Factor : 2
 Conversion Factor : 5.15
 Probe Sensitivity : 1.20 1.20 1.20 $\mu\text{V}/(\text{V}/\text{m})^2$
 Compression Point : 95.00 mV
 Offset : 1.56 mm

1 gram SAR value : 0.592 W/kg
 10 gram SAR value : 0.288 W/kg
 Area Scan Peak SAR : 0.608 W/kg
 Zoom Scan Peak SAR : 0.913 W/kg

Plot 30#

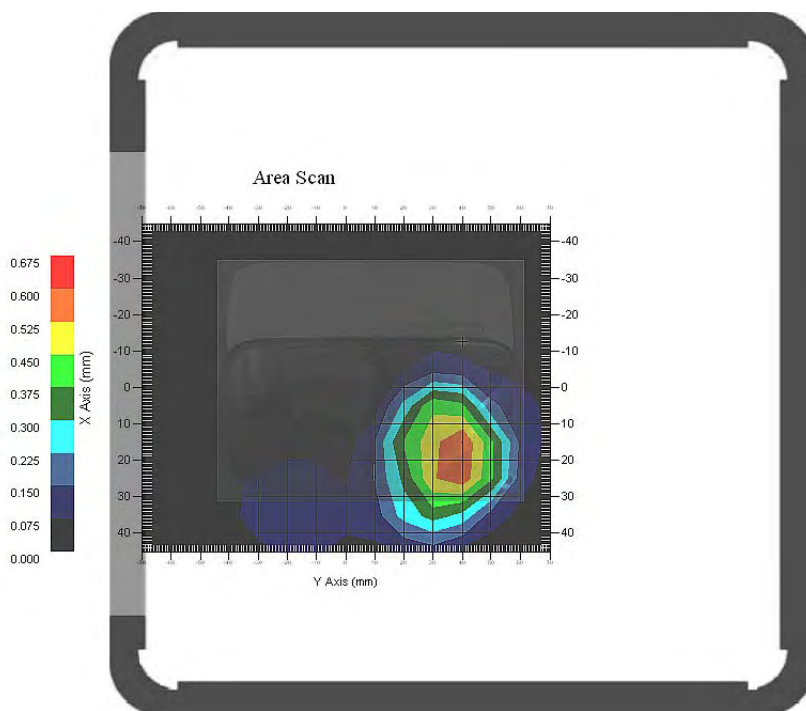

Test Laboratory: Bay Area Compliance Lab Corp. (Shenzhen)

Left Head Cheek-close keypad (1900 MHz High Channel)

Measurement Data

Test mode : GSM
 Crest Factor : 8
 Scan Type : Complete
 Area Scan : 13x9x1 : Measurement x=10mm, y=10mm, z=4mm
 Zoom Scan : 7x7x7 : Measurement x=5mm, y=5mm, z=5mm
 Power Drift-Start : 0.476 W/kg
 Power Drift-Finish : 0.466 W/kg
 Power Drift (%) : -2.371

Tissue Data

Type : HEAD
 Frequency : 1900.00 MHz
 Epsilon : 40.11 F/m
 Sigma : 1.44 S/m
 Density : 1000.00 kg/cu. m

Probe Data

Serial No. : 500-00283
 Frequency : 1900.00 MHz
 Duty Cycle Factor : 8
 Conversion Factor : 5.25
 Probe Sensitivity : 1.20 1.20 1.20 $\mu\text{V}/(\text{V}/\text{m})^2$
 Compression Point : 95.00 mV
 Offset : 1.56 mm

1 gram SAR value : 0.523 W/kg
 10 gram SAR value : 0.201 W/kg
 Area Scan Peak SAR : 0.548 W/kg
 Zoom Scan Peak SAR : 0.970 W/kg

Plot 31#

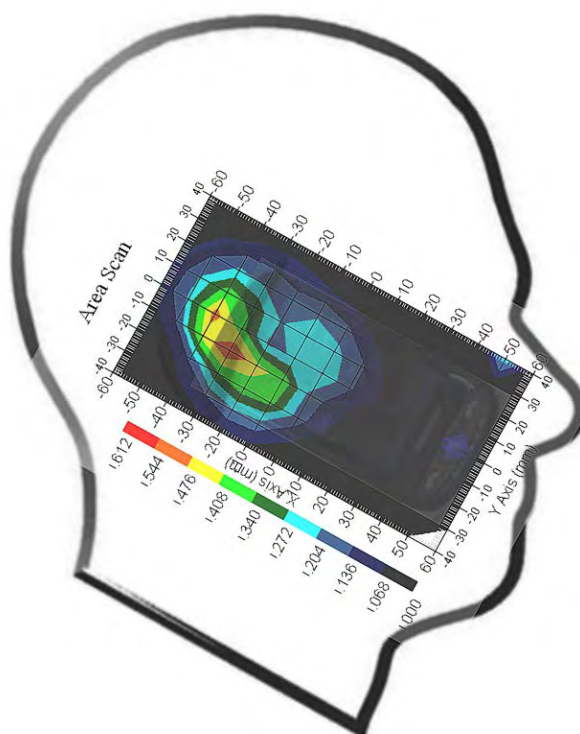

Test Laboratory: Bay Area Compliance Lab Corp. (Shenzhen)

Left Head Tilt-close keypad(1900 MHz High Channel)

Measurement Data

Test mode : GSM
 Crest Factor : 8
 Scan Type : Complete
 Area Scan : 13x9x1 : Measurement x=10mm, y=10mm, z=4mm
 Zoom Scan : 7x7x7 : Measurement x=5mm, y=5mm, z=5mm
 Power Drift-Start : 0.298 W/kg
 Power Drift-Finish : 0.292 W/kg
 Power Drift (%) : -2.184

Tissue Data

Type : HEAD
 Frequency : 1900.00 MHz
 Epsilon : 40.11 F/m
 Sigma : 1.44 S/m
 Density : 1000.00 kg/cu. m

Probe Data

Serial No. : 500-00283
 Frequency : 1900.00 MHz
 Duty Cycle Factor : 8
 Conversion Factor : 5.25
 Probe Sensitivity : 1.20 1.20 1.20 $\mu\text{V}/(\text{V}/\text{m})^2$
 Compression Point : 95.00 mV
 Offset : 1.56 mm

1 gram SAR value : 0.456 W/kg
 10 gram SAR value : 0.240 W/kg
 Area Scan Peak SAR : 0.600 W/kg
 Zoom Scan Peak SAR : 1.091 W/kg

Plot 32#

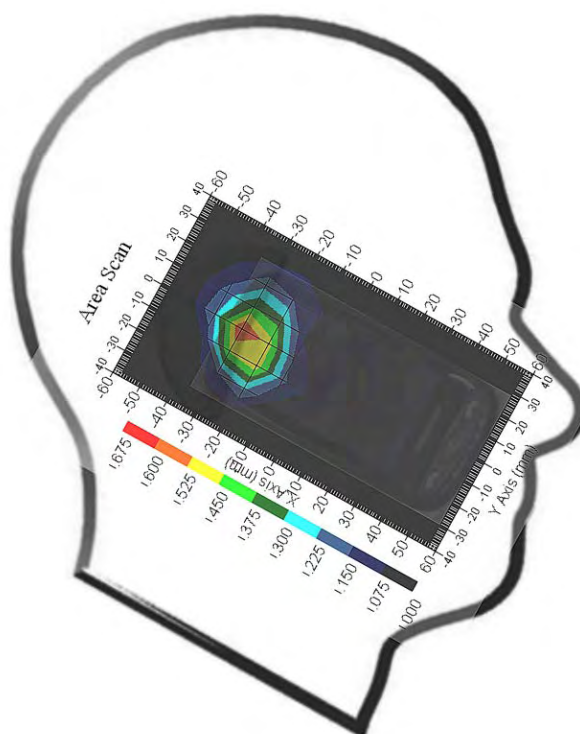

Test Laboratory: Bay Area Compliance Lab Corp. (Shenzhen)

Right Head Cheek-close keypad (1900 MHz Low Channel)

Measurement Data

Test mode : GSM
 Crest Factor : 8
 Scan Type : Complete
 Area Scan : 13x9x1 : Measurement x=10mm, y=10mm, z=4mm
 Zoom Scan : 7x7x7 : Measurement x=5mm, y=5mm, z=5mm
 Power Drift-Start : 0.341 W/kg
 Power Drift-Finish : 0.350 W/kg
 Power Drift (%) : 2.797

Tissue Data

Type : HEAD
 Frequency : 1900.00 MHz
 Epsilon : 40.11 F/m
 Sigma : 1.44 S/m
 Density : 1000.00 kg/cu. m

Probe Data

Serial No. : 500-00283
 Frequency : 1900.00 MHz
 Duty Cycle Factor : 8
 Conversion Factor : 5.25
 Probe Sensitivity : 1.20 1.20 1.20 $\mu\text{V}/(\text{V}/\text{m})^2$
 Compression Point : 95.00 mV
 Offset : 1.56 mm

1 gram SAR value : 0.519 W/kg
 10 gram SAR value : 0.244 W/kg
 Area Scan Peak SAR : 0.512 W/kg
 Zoom Scan Peak SAR : 0.990 W/kg

Plot 33#

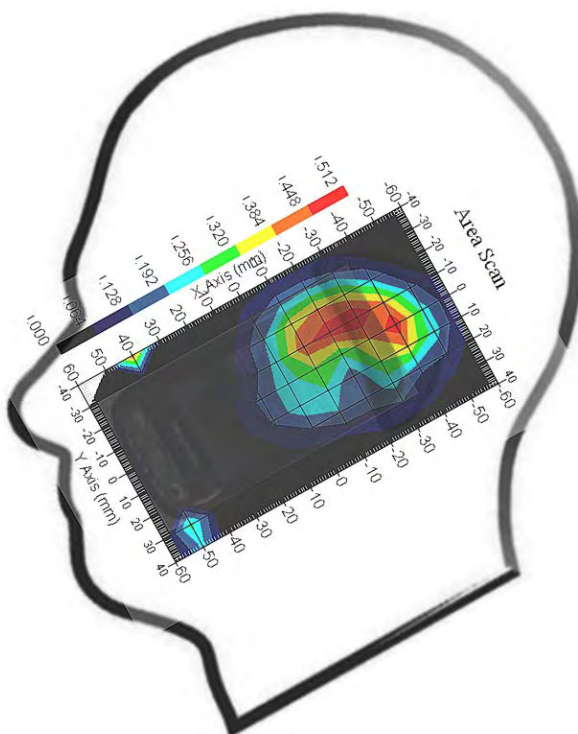

Test Laboratory: Bay Area Compliance Lab Corp. (Shenzhen)

Right Head Cheek-close keypad (1900 MHz Middle Channel)

Measurement Data

Test mode : GSM
 Crest Factor : 8
 Scan Type : Complete
 Area Scan : 13x9x1 : Measurement x=10mm, y=10mm, z=4mm
 Zoom Scan : 7x7x7 : Measurement x=5mm, y=5mm, z=5mm
 Power Drift-Start : 0.535 W/kg
 Power Drift-Finish : 0.526 W/kg
 Power Drift (%) : -1.755

Tissue Data

Type : HEAD
 Frequency : 1900.00 MHz
 Epsilon : 40.11 F/m
 Sigma : 1.44 S/m
 Density : 1000.00 kg/cu. m

Probe Data

Serial No. : 500-00283
 Frequency : 1900.00 MHz
 Duty Cycle Factor : 8
 Conversion Factor : 5.25
 Probe Sensitivity : 1.20 1.20 1.20 $\mu\text{V}/(\text{V}/\text{m})^2$
 Compression Point : 95.00 mV
 Offset : 1.56 mm

1 gram SAR value : 0.524 W/kg
 10 gram SAR value : 0.212 W/kg
 Area Scan Peak SAR : 0.605 W/kg
 Zoom Scan Peak SAR : 1.090 W/kg

Plot 34#

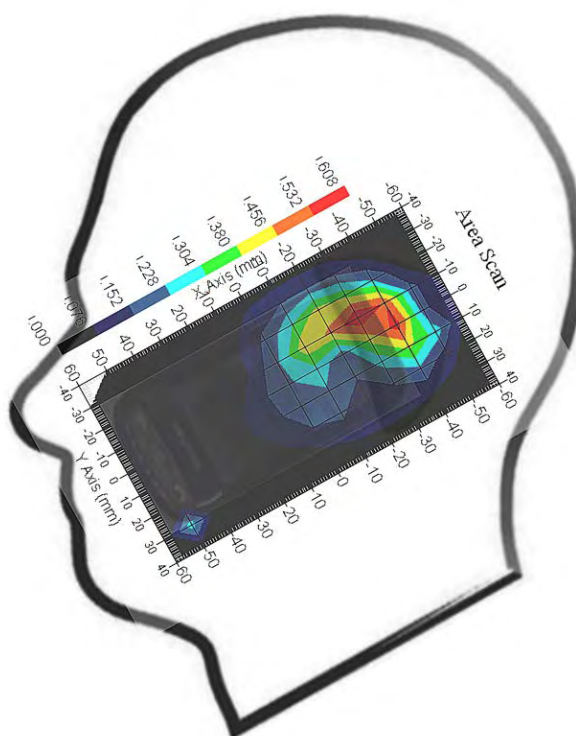

Test Laboratory: Bay Area Compliance Lab Corp. (Shenzhen)

Right Head Cheek-close (1900 MHz High Channel)

Measurement Data

Test mode : GSM
 Crest Factor : 8
 Scan Type : Complete
 Area Scan : 13x9x1 : Measurement x=10mm, y=10mm, z=4mm
 Zoom Scan : 7x7x7 : Measurement x=5mm, y=5mm, z=5mm
 Power Drift-Start : 0.450 W/kg
 Power Drift-Finish : 0.451 W/kg
 Power Drift (%) : 0.397

Tissue Data

Type : HEAD
 Frequency : 1900.00 MHz
 Epsilon : 40.11 F/m
 Sigma : 1.44 S/m
 Density : 1000.00 kg/cu. m

Probe Data

Serial No. : 500-00283
 Frequency : 1900.00 MHz
 Duty Cycle Factor : 8
 Conversion Factor : 5.25
 Probe Sensitivity : 1.20 1.20 1.20 $\mu\text{V}/(\text{V}/\text{m})^2$
 Compression Point : 95.00 mV
 Offset : 1.56 mm

1 gram SAR value : 0.531 W/kg
 10 gram SAR value : 0.197 W/kg
 Area Scan Peak SAR : 0.496 W/kg
 Zoom Scan Peak SAR : 0.920 W/kg

Plot 35#

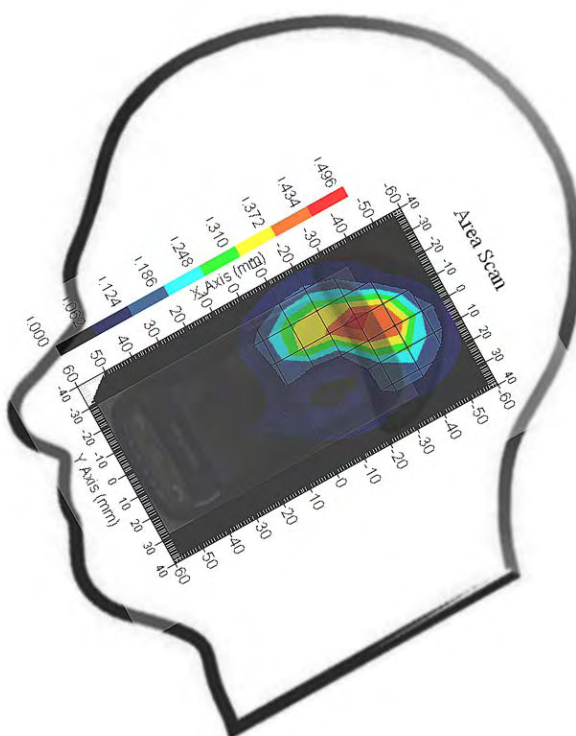

Test Laboratory: Bay Area Compliance Lab Corp. (Shenzhen)

Right Head Tilt-close keypad (1900 MHz High Channel)

Measurement Data

Test mode : GSM
 Crest Factor : 8
 Scan Type : Complete
 Area Scan : 13x9x1 : Measurement x=10mm, y=10mm, z=4mm
 Zoom Scan : 7x7x7 : Measurement x=5mm, y=5mm, z=5mm
 Power Drift-Start : 0.352 W/kg
 Power Drift-Finish : 0.353 W/kg
 Power Drift (%) : 0.355

Tissue Data

Type : HEAD
 Frequency : 1900.00 MHz
 Epsilon : 40.11 F/m
 Sigma : 1.44 S/m
 Density : 1000.00 kg/cu. m

Probe Data

Serial No. : 500-00283
 Frequency : 1900.00 MHz
 Duty Cycle Factor : 8
 Conversion Factor : 5.25
 Probe Sensitivity : 1.20 1.20 1.20 $\mu\text{V}/(\text{V}/\text{m})^2$
 Compression Point : 95.00 mV
 Offset : 1.56 mm

1 gram SAR value : 0.472 W/kg
 10 gram SAR value : 0.204 W/kg
 Area Scan Peak SAR : 0.547 W/kg
 Zoom Scan Peak SAR : 1.061 W/kg

Plot 36#

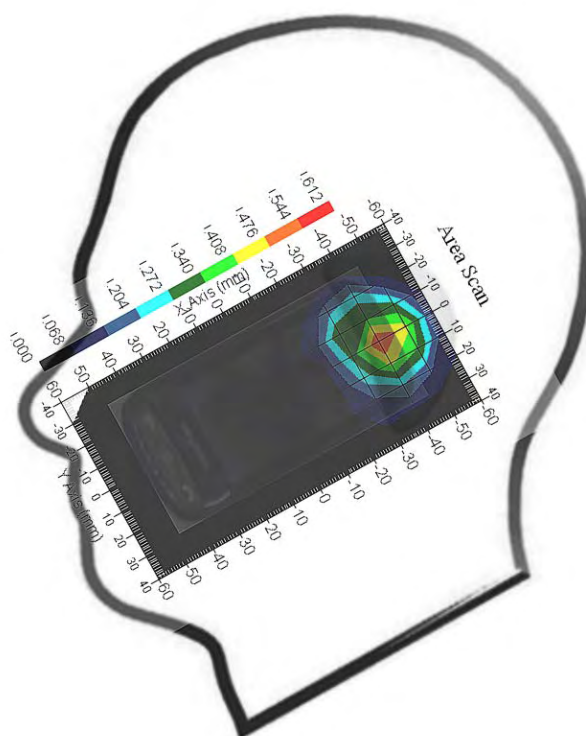

Test Laboratory: Bay Area Compliance Lab Corp. (Shenzhen)

Body- worn Back – close keypad (1900 MHz High Channel)

Measurement Data

Test mode : GSM
 Crest Factor : 8
 Scan Type : Complete
 Area Scan : 9x13x1 : Measurement x=10mm, y=10mm, z=4mm
 Zoom Scan : 7x7x7 : Measurement x=5mm, y=5mm, z=5mm
 Power Drift-Start : 0.216 W/kg
 Power Drift-Finish : 0.214 W/kg
 Power Drift (%) : -1.138

Tissue Data

Type : BODY
 Frequency : 1900.00 MHz
 Epsilon : 54.18 F/m
 Sigma : 1.48 S/m
 Density : 1000.00 kg/cu. m

Probe Data

Serial No. : 500-00283
 Frequency : 1900.00 MHz
 Duty Cycle Factor : 8
 Conversion Factor : 5.15
 Probe Sensitivity : 1.20 1.20 1.20 $\mu\text{V}/(\text{V}/\text{m})^2$
 Compression Point : 95.00 mV
 Offset : 1.56 mm

1 gram SAR value : 0.162 W/kg
 10 gram SAR value : 0.098 W/kg
 Area Scan Peak SAR : 0.161 W/kg
 Zoom Scan Peak SAR : 0.430 W/kg

Plot 37#

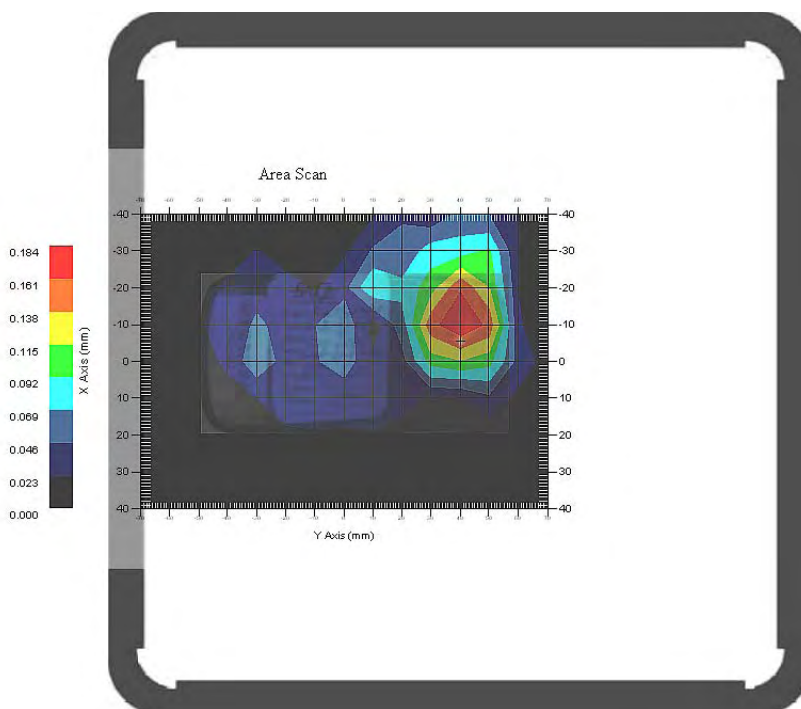

Test Laboratory: Bay Area Compliance Lab Corp. (Shenzhen)

Body- worn Back – close keypad (1900 MHz Low Channel)

Measurement Data

Test mode : GPRS
 Crest Factor : 2
 Scan Type : Complete
 Area Scan : 9x13x1 : Measurement x=10mm, y=10mm, z=4mm
 Zoom Scan : 7x7x7 : Measurement x=5mm, y=5mm, z=5mm
 Power Drift-Start : 0.243 W/kg
 Power Drift-Finish : 0.240 W/kg
 Power Drift (%) : -1.125

Tissue Data

Type : BODY
 Frequency : 1900.00 MHz
 Epsilon : 54.18 F/m
 Sigma : 1.48 S/m
 Density : 1000.00 kg/cu. m

Probe Data

Serial No. : 500-00283
 Frequency : 1900.00 MHz
 Duty Cycle Factor : 2
 Conversion Factor : 5.15
 Probe Sensitivity : 1.20 1.20 1.20 $\mu\text{V}/(\text{V}/\text{m})^2$
 Compression Point : 95.00 mV
 Offset : 1.56 mm

1 gram SAR value : 0.453 W/kg
 10 gram SAR value : 0.204 W/kg
 Area Scan Peak SAR : 0.440 W/kg
 Zoom Scan Peak SAR : 0.870 W/kg

Plot 38#

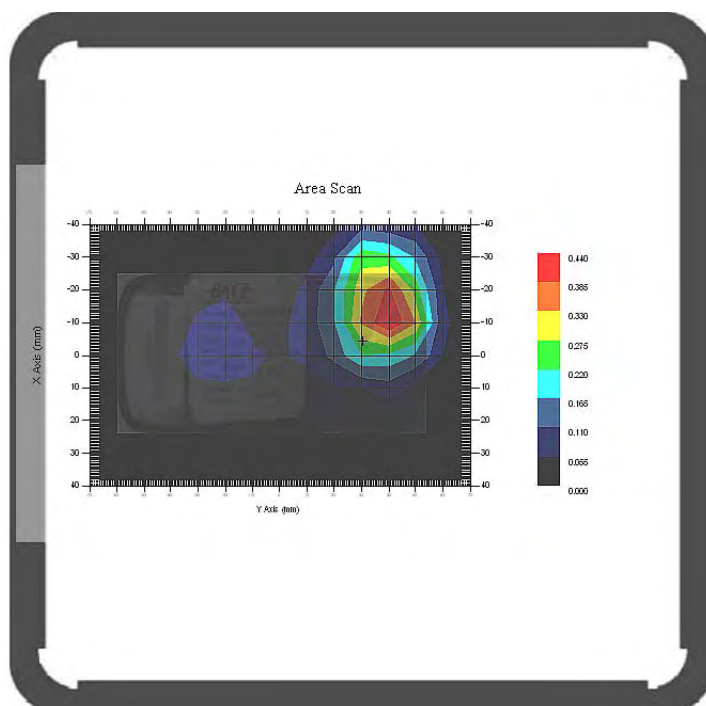

Test Laboratory: Bay Area Compliance Lab Corp. (Shenzhen)

Body- worn Back – close keypad (1900 MHz Middle Channel)

Measurement Data

Test mode : GPRS
 Crest Factor : 2
 Scan Type : Complete
 Area Scan : 9x13x1 : Measurement x=10mm, y=10mm, z=4mm
 Zoom Scan : 7x7x7 : Measurement x=5mm, y=5mm, z=5mm
 Power Drift-Start : 0.241 W/kg
 Power Drift-Finish : 0.237 W/kg
 Power Drift (%) : -1.527

Tissue Data

Type : BODY
 Frequency : 1900.00 MHz
 Epsilon : 54.18 F/m
 Sigma : 1.48 S/m
 Density : 1000.00 kg/cu. m

Probe Data

Serial No. : 500-00283
 Frequency : 1900.00 MHz
 Duty Cycle Factor : 2
 Conversion Factor : 5.15
 Probe Sensitivity : 1.20 1.20 1.20 $\mu\text{V}/(\text{V}/\text{m})^2$
 Compression Point : 95.00 mV
 Offset : 1.56 mm

1 gram SAR value : 0.510 W/kg
 10 gram SAR value : 0.194 W/kg
 Area Scan Peak SAR : 0.504 W/kg
 Zoom Scan Peak SAR : 0.830 W/kg

Plot 39#

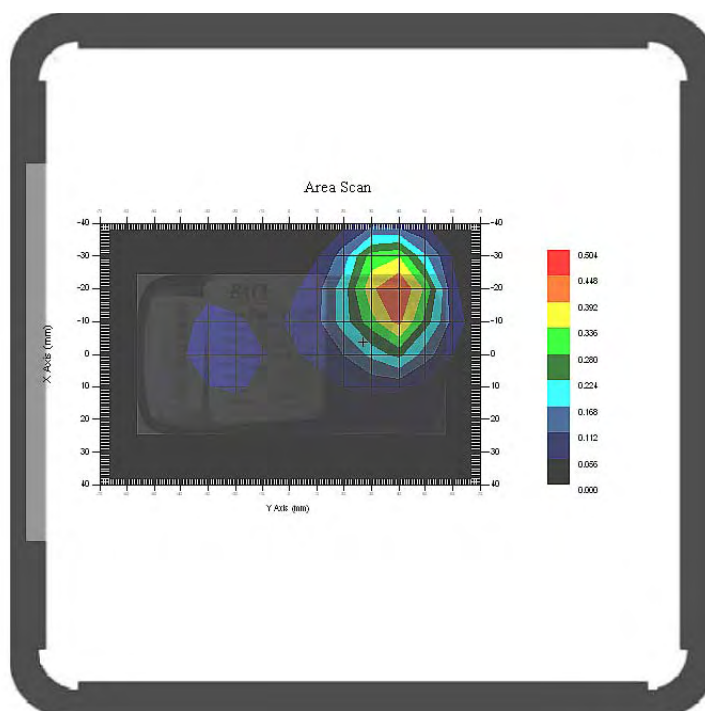

Test Laboratory: Bay Area Compliance Lab Corp. (Shenzhen)

Body- worn Back – close keypad (1900 MHz High Channel)

Measurement Data

Test mode : GPRS
 Crest Factor : 2
 Area Scan : 9x13x1 : Measurement x=10mm, y=10mm, z=4mm
 Zoom Scan : 7x7x7 : Measurement x=5mm, y=5mm, z=5mm
 Power Drift-Start : 0.242 W/kg
 Power Drift-Finish : 0.232 W/kg
 Power Drift (%) : -4.258

Tissue Data

Type : BODY
 Frequency : 1900.00 MHz
 Epsilon : 54.18 F/m
 Sigma : 1.48 S/m
 Density : 1000.00 kg/cu. m

Probe Data

Serial No. : 500-00283
 Frequency : 1900.00 MHz
 Duty Cycle Factor : 2
 Conversion Factor : 5.15
 Probe Sensitivity : 1.20 1.20 1.20 $\mu\text{V}/(\text{V}/\text{m})^2$
 Compression Point : 95.00 mV
 Offset : 1.56 mm

1 gram SAR value : 0.455 W/kg
 10 gram SAR value : 0.184 W/kg
 Area Scan Peak SAR : 0.392 W/kg
 Zoom Scan Peak SAR : 0.810 W/kg

Plot 40#

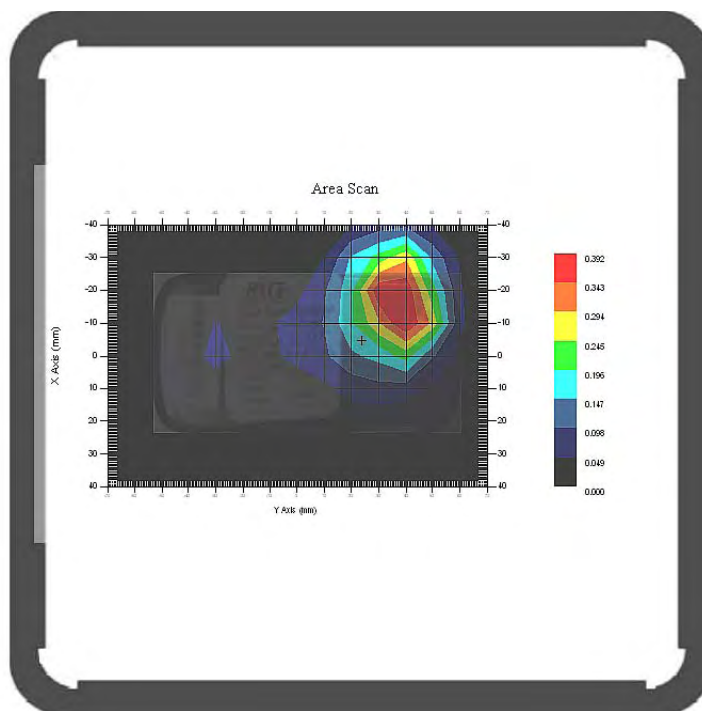

APPENDIX A – MEASUREMENT UNCERTAINTY

The uncertainty budget has been determined for the measurement system and is given in the following Table.

Measurement uncertainty for 300 MHz to 3 GHz

Source of Uncertainty	Tolerance Value	Probability Distribution	Divisor	c_1^1 (1-g)	c_1^1 (10-g)	Standard Uncertainty (1-g) %	Standard Uncertainty (10-g) %
Measurement System							
Probe Calibration	3.5	normal	1	1	1	3.5	3.5
Axial Isotropy	3.7	rectangular	$\sqrt{3}$	$(1-cp)^{1/2}$	$(1-cp)^{1/2}$	1.5	1.5
Hemispherical Isotropy	10.9	rectangular	$\sqrt{3}$	\sqrt{cp}	\sqrt{cp}	4.4	4.4
Boundary Effect	1.0	rectangular	$\sqrt{3}$	1	1	0.6	0.6
Linearity	4.7	rectangular	$\sqrt{3}$	1	1	2.7	2.7
Detection Limit	1.0	rectangular	$\sqrt{3}$	1	1	0.6	0.6
Readout Electronics	1.0	normal	1	1	1	1.0	1.0
Response Time	0.8	rectangular	$\sqrt{3}$	1	1	0.5	0.5
Integration Time	1.7	rectangular	$\sqrt{3}$	1	1	1.0	1.0
RF Ambient Condition -Noise	3.0	rectangular	$\sqrt{3}$	1	1	1.7	1.7
RF Ambient Condition - Reflections	3.0	rectangular	$\sqrt{3}$	1	1	1.7	1.7
Probe Positioner Mech. Restrictions	0.4	rectangular	$\sqrt{3}$	1	1	0.2	0.2
Restriction							
Probe Positioning with respect to Phantom Shell	2.9	rectangular	$\sqrt{3}$	1	1	1.7	1.7
Extrapolation and Integration	3.7	rectangular	$\sqrt{3}$	1	1	2.1	2.1
Test Sample Positioning	4.0	normal	1	1	1	4.0	4.0
Device Holder Uncertainty	2.0	normal	1	1	1	2.0	2.0
Drift of Output Power	0.4	rectangular	$\sqrt{3}$	1	1	0.2	0.2
Phantom and Setup							
Phantom Uncertainty(shape & thickness tolerance)	3.4	rectangular	$\sqrt{3}$	1	1	2.0	2.0
Liquid Conductivity(target)	5.0	rectangular	$\sqrt{3}$	0.7	0.5	2.0	1.4
Liquid Conductivity(meas.)	2.5	normal	1	0.7	0.5	1.8	1.3
Liquid Permittivity(target)	5.0	rectangular	$\sqrt{3}$	0.6	0.5	1.7	1.4
Liquid Permittivity(meas.)	2.5	normal	1	0.6	0.5	1.5	1.3
Combined Uncertainty		RSS				9.7	9.4
Combined Uncertainty (coverage factor=2)		Normal (k=2)				19.4	18.8

APPENDIX B – PROBE CALIBRATION CERTIFICATES

NCL CALIBRATION LABORATORIES

Calibration File No.: CP-1319

Client.: BACL

CERTIFICATE OF CALIBRATION

It is certified that the equipment identified below has been calibrated in the **NCL CALIBRATION LABORATORIES** by qualified personnel following recognized procedures and using transfer standards traceable to NRC/NIST.

Equipment: Miniature Isotropic RF Probe 835 MHz

Manufacturer: APREL Laboratories

Model No.: E-020

Serial No.: 283

Calibration in Head Tissue

Calibration Procedure: SSI/DRB-TP-D01-032-E020-V2

Project No: BACB-E020-5735

Calibrated: 20th July 2011

Released on: 20th July 2011

This Calibration Certificate is Incomplete Unless Accompanied with the Calibration Results Summary

Released By: _____

NCL CALIBRATION LABORATORIES

51 SPECTRUM WAY
NEPEAN, ONTARIO
CANADA K2R 1E6

Division of APREL Lab.
TEL: (613) 820-4988
FAX: (613) 820-4161

NCL Calibration Laboratories

Division of APREL Laboratories.

Introduction

This Calibration Report reproduces the results of the calibration performed in line with the SSI/DRB-TP-D01-032-E020-V2 E-Field Probe Calibration Procedure. The results contained within this report are for APREL E-Field Probe E-020 283.

References

SSI/DRB-TP-D01-032-E020-V2 E-Field Probe Calibration Procedure
IEEE 1528 "Recommended Practice for Determining the Peak Spatial-Average Specific Absorption Rate (SAR) in the Human Body Due to Wireless Communications Devices: Experimental Techniques"
SSI-TP-011 Tissue Calibration Procedure

Conditions

Probe 283 was a re-calibration.

Ambient Temperature of the Laboratory: 22 °C +/- 0.5°C

Temperature of the Tissue: 21 °C +/- 0.5°C

We the undersigned attest that to the best of our knowledge the calibration of this probe has been accurately conducted and that all information contained within this report has been reviewed for accuracy.



Stuart Nicol

Jesse Hones

Page 2 of 10

This page has been reviewed for content and attested to on Page 2 of this document.

NCL Calibration Laboratories

Division of APREL Laboratories.

Calibration Results Summary

Probe Type:	E-Field Probe E-020
Serial Number:	283
Frequency:	835 MHz
Sensor Offset:	1.56 mm
Sensor Length:	2.5 mm
Tip Enclosure:	Ertalyte*
Tip Diameter:	<5 mm
Tip Length:	60 mm
Total Length:	290 mm

*Resistive to recommended tissue recipes per IEEE-1528

Sensitivity in Air

Channel X:	1.2 $\mu\text{V}/(\text{V}/\text{m})^2$
Channel Y:	1.2 $\mu\text{V}/(\text{V}/\text{m})^2$
Channel Z:	1.2 $\mu\text{V}/(\text{V}/\text{m})^2$
Diode Compression Point:	95 mV

Page 3 of 10

This page has been reviewed for content and attested to on Page 2 of this document.

NCL Calibration Laboratories

Division of APREL Laboratories.

Sensitivity in Head Tissue Measured

Frequency: 835 MHz
Epsilon: 41.05 (+/-5%) **Sigma:** 0.91 S/m (+/-5%)

ConvF

Channel X: 6.5
Channel Y: 6.5
Channel Z: 6.5

Tissue sensitivity values were calculated using the load impedance of the APREL Laboratories Daq-Paq.

Boundary Effect:

Uncertainty resulting from the boundary effect is less than 2% for the distance between the tip of the probe and the tissue boundary, when less than 2.44mm.

Spatial Resolution:

The measured probe tip diameter is 5 mm (+/- 0.01 mm) and therefore meets the requirements of SSI/DRB-TP-D01-032 for spatial resolution.

Page 4 of 10

This page has been reviewed for content and attested to on Page 2 of this document.

NCL Calibration Laboratories

Division of APREL Laboratories.

Receiving Pattern 835 MHz (Air)

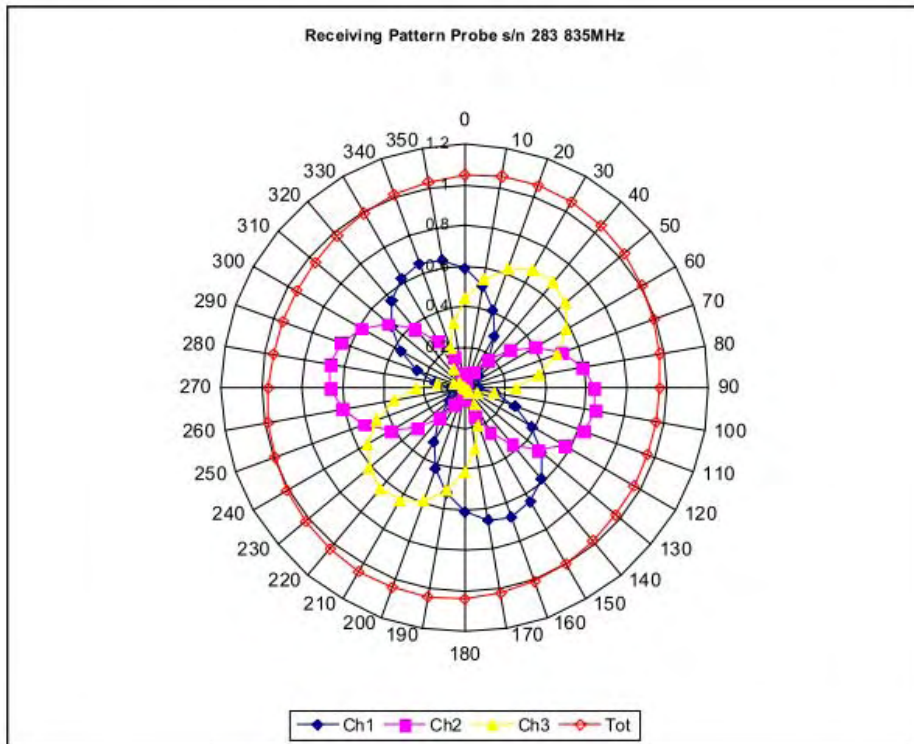

Page 5 of 10

This page has been reviewed for content and attested to on Page 2 of this document.

NCL Calibration Laboratories

Division of APREL Laboratories.

Isotropy Error 835 MHz (Air)

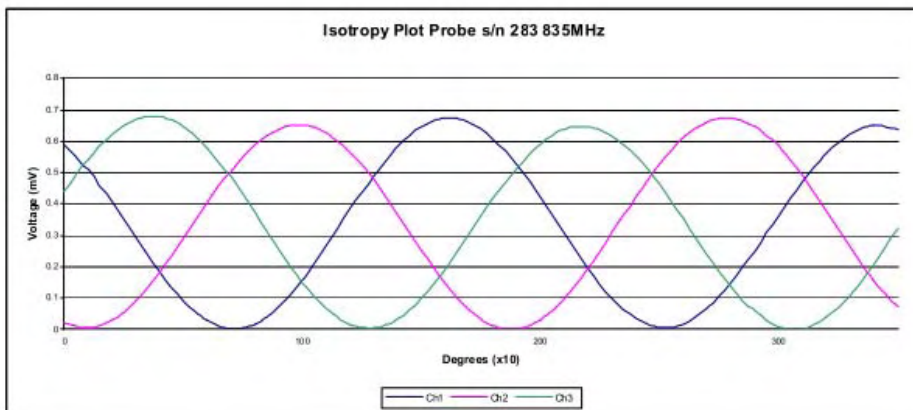
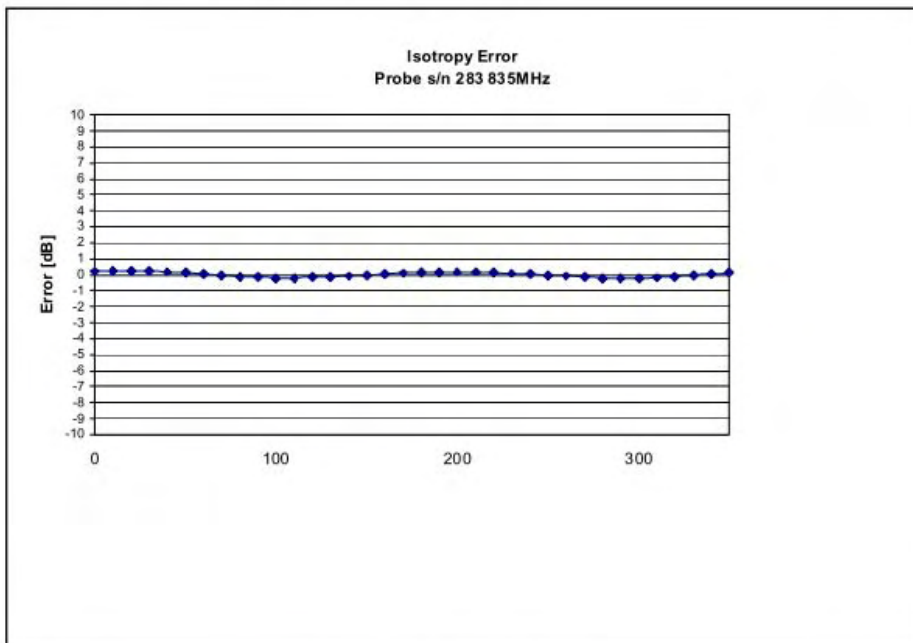

Isotropicity Tissue: 0.10 dB

Page 6 of 10
This page has been reviewed for content and attested to on Page 2 of this document.

NCL Calibration Laboratories

Division of APREL Laboratories.

Dynamic Range

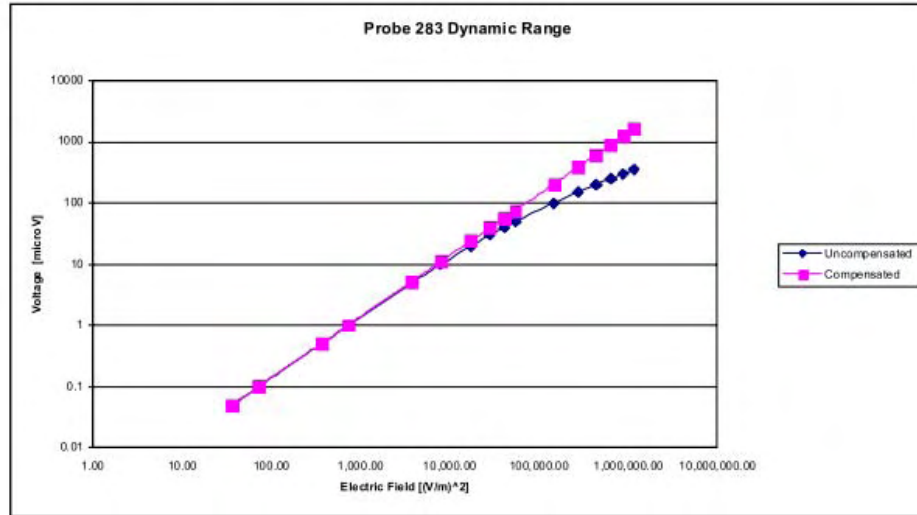

Page 7 of 10

This page has been reviewed for content and attested to on Page 2 of this document.

NCL Calibration Laboratories

Division of APREL Laboratories.

Video Bandwidth

Probe Frequency Characteristics

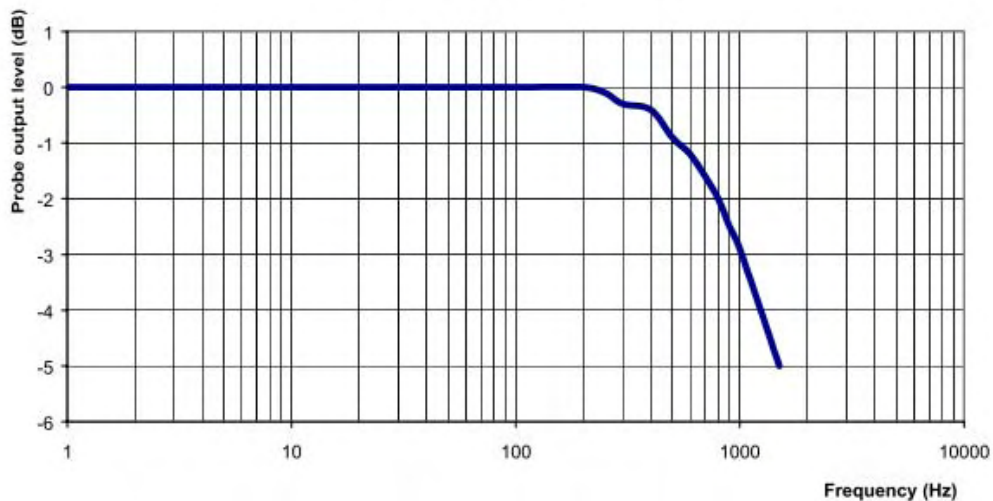

Video Bandwidth at 500 Hz 1 dB
Video Bandwidth at 1.02 KHz: 3 dB

Page 8 of 10
This page has been reviewed for content and attested to on Page 2 of this document.

NCL Calibration Laboratories

Division of APREL Laboratories.

Conversion Factor Uncertainty Assessment

Frequency:	835MHz
Epsilon: 41.05 (+/-5%)	Sigma: 0.91 S/m (+/-5%)
ConvF	
Channel X: 6.5	7%(K=2)
Channel Y: 6.5	7%(K=2)
Channel Z: 6.5	7%(K=2)

To minimize the uncertainty calculation all tissue sensitivity values were calculated using a load impedance of 5 MΩ.

Boundary Effect:

For a distance of 2.5mm the evaluated uncertainty (increase in the probe sensitivity) is less than 2%.

Page 9 of 10
This page has been reviewed for content and attested to on Page 2 of this document.

NCL Calibration Laboratories

Division of APREL Laboratories.

Test Equipment

The test equipment used during Probe Calibration, manufacturer, model number and, current calibration status are listed and located on the main APREL server R:\NCL\Calibration Equipment\Instrument List May 2011.

Page 10 of 10

This page has been reviewed for content and attested to on Page 2 of this document.

NCL CALIBRATION LABORATORIES

Calibration File No.: CP-1320

Client.: BACL

CERTIFICATE OF CALIBRATION

It is certified that the equipment identified below has been calibrated in the **NCL CALIBRATION LABORATORIES** by qualified personnel following recognized procedures and using transfer standards traceable to NRC/NIST.

Equipment: Miniature Isotropic RF Probe 835 MHz

Manufacturer: APREL Laboratories

Model No.: E-020

Serial No.: 283

Calibration in Body Tissue

Calibration Procedure: SSI/DRB-TP-D01-032-E020-V2

Project No: BACB-E020-5737

Calibrated: 20th July 2011

Released on: 20th July 2011

This Calibration Certificate is Incomplete Unless Accompanied with the Calibration Results Summary

Released By: _____

NCL CALIBRATION LABORATORIES

51 SPECTRUM WAY
NEPEAN, ONTARIO
CANADA K2R 1E6

Division of APREL Lab.
TEL: (613) 820-4988
FAX: (613) 820-4161

NCL Calibration Laboratories

Division of APREL Laboratories.

Introduction

This Calibration Report reproduces the results of the calibration performed in line with the SSI/DRB-TP-D01-032-E020-V2 E-Field Probe Calibration Procedure. The results contained within this report are for APREL E-Field Probe E-020 283.

References

SSI/DRB-TP-D01-032-E020-V2 E-Field Probe Calibration Procedure
IEEE 1528 "Recommended Practice for Determining the Peak Spatial-Average Specific Absorption Rate (SAR) in the Human Body Due to Wireless Communications Devices: Experimental Techniques"
SSI-TP-011 Tissue Calibration Procedure

Conditions

Probe 283 was a re- calibration.

Ambient Temperature of the Laboratory: 22 °C +/- 0.5°C
Temperature of the Tissue: 21 °C +/- 0.5°C

We the undersigned attest that to the best of our knowledge the calibration of this probe has been accurately conducted and that all information contained within this report has been reviewed for accuracy.

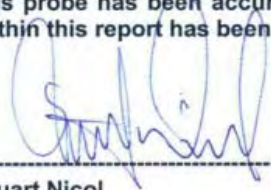

Stuart Nicol

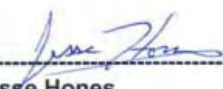

Jesse Hones

Page 2 of 10
This page has been reviewed for content and attested to on Page 2 of this document.

NCL Calibration Laboratories

Division of APREL Laboratories.

Calibration Results Summary

Probe Type:	E-Field Probe E-020
Serial Number:	283
Frequency:	835 MHz
Sensor Offset:	1.56 mm
Sensor Length:	2.5 mm
Tip Enclosure:	Ertalyte*
Tip Diameter:	<5 mm
Tip Length:	60 mm
Total Length:	290 mm

*Resistive to recommended tissue recipes per IEEE-1528

Sensitivity in Air

Channel X:	1.2 $\mu\text{V}/(\text{V}/\text{m})^2$
Channel Y:	1.2 $\mu\text{V}/(\text{V}/\text{m})^2$
Channel Z:	1.2 $\mu\text{V}/(\text{V}/\text{m})^2$
Diode Compression Point:	95 mV

Page 3 of 10
This page has been reviewed for content and attested to on Page 2 of this document.

NCL Calibration Laboratories

Division of APREL Laboratories.

Sensitivity in Body Tissue Measured

Frequency: 835 MHz
Epsilon: 55.95 (+/-5%) **Sigma:** 0.99 S/m (+/-5%)

ConvF

Channel X: 6.7
Channel Y: 6.7
Channel Z: 6.7

Tissue sensitivity values were calculated using the load impedance of the APREL Laboratories Daq-Paq.

Boundary Effect:

Uncertainty resulting from the boundary effect is less than 2% for the distance between the tip of the probe and the tissue boundary, when less than 2.44mm.

Spatial Resolution:

The measured probe tip diameter is 5 mm (+/- 0.01 mm) and therefore meets the requirements of SSI/DRB-TP-D01-032 for spatial resolution.

Page 4 of 10
This page has been reviewed for content and attested to on Page 2 of this document.

NCL Calibration Laboratories

Division of APREL Laboratories.

Receiving Pattern 835 MHz (Air)

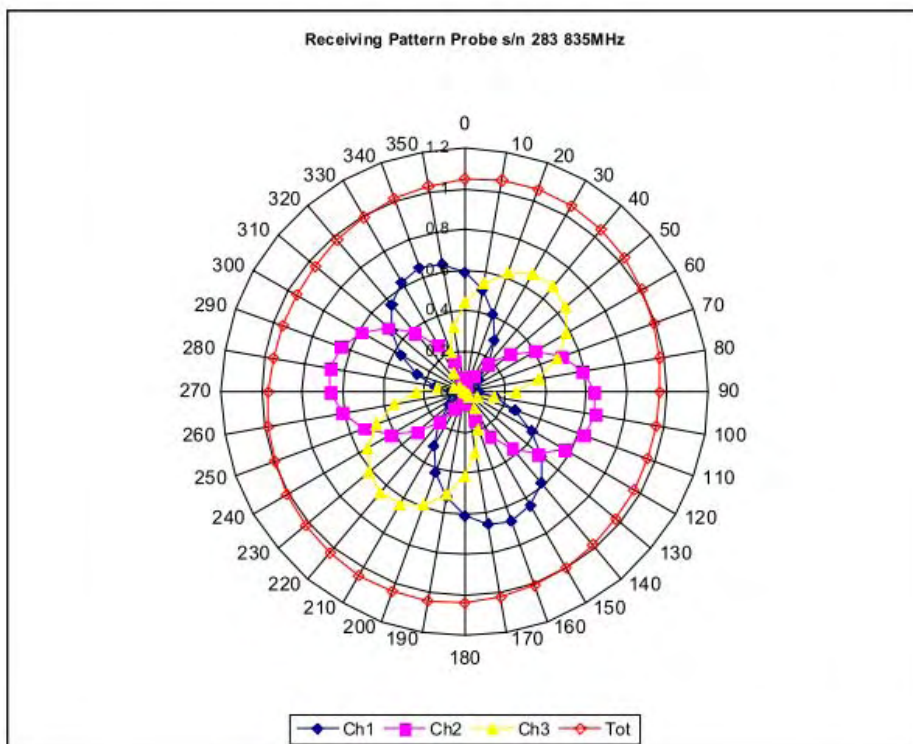

Page 5 of 10
This page has been reviewed for content and attested to on Page 2 of this document.

NCL Calibration Laboratories

Division of APREL Laboratories.

Isotropy Error 835 MHz (Air)

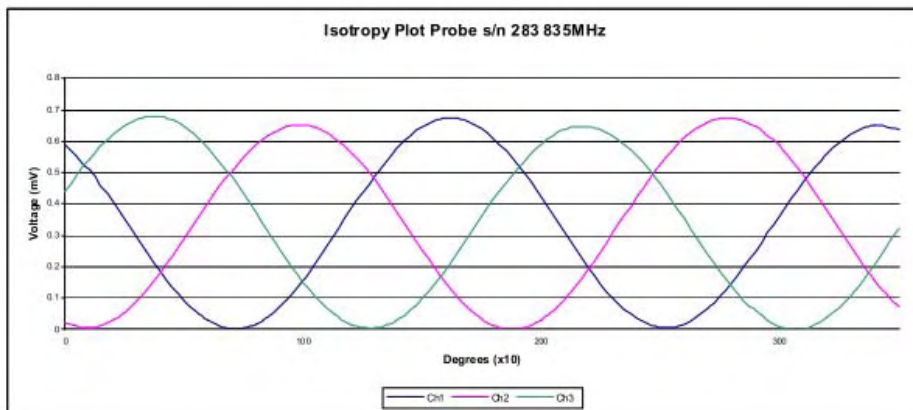
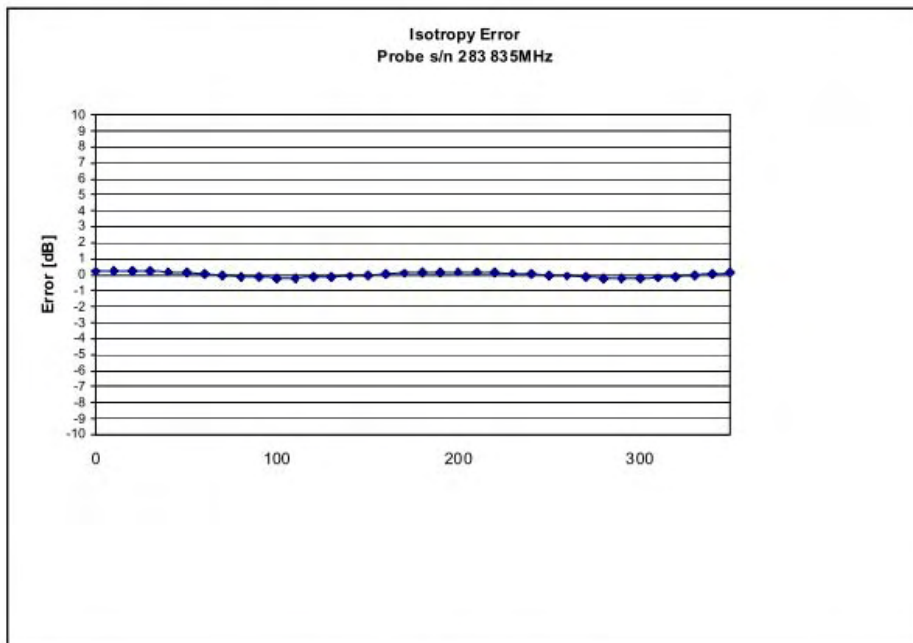

Isotropicity in Tissue: 0.10 dB

Page 6 of 10
This page has been reviewed for content and attested to on Page 2 of this document.

NCL Calibration Laboratories

Division of APREL Laboratories.

Dynamic Range

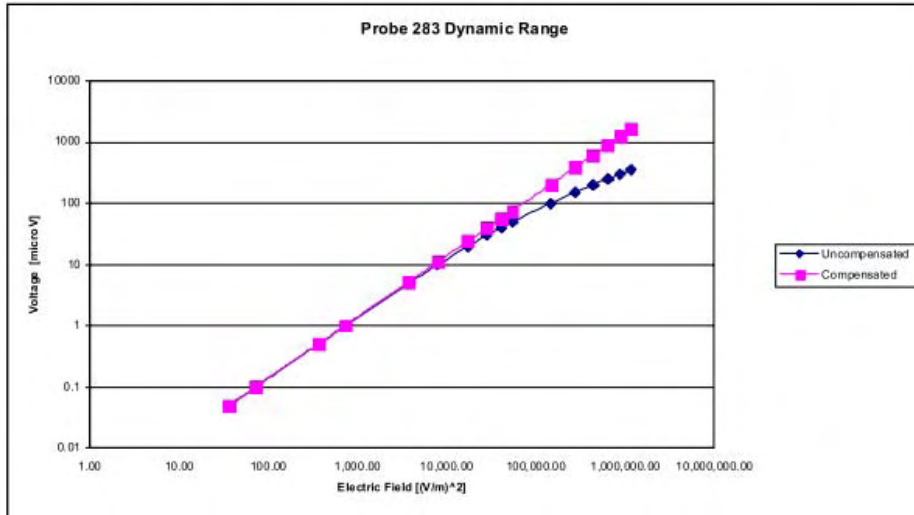

Page 7 of 10

This page has been reviewed for content and attested to on Page 2 of this document.

NCL Calibration Laboratories

Division of APREL Laboratories.

Video Bandwidth

Probe Frequency Characteristics

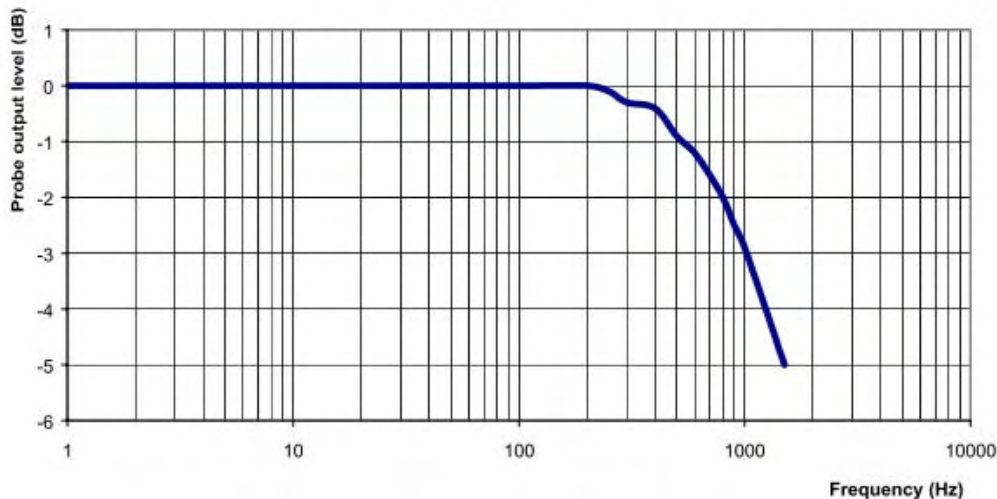

Video Bandwidth at 500 Hz 1 dB
Video Bandwidth at 1.02 KHz: 3 dB

NCL Calibration Laboratories

Division of APREL Laboratories.

Conversion Factor Uncertainty Assessment

Frequency: 835MHz
Epsilon: 55.95 (+/-5%) **Sigma:** 0.99 S/m (+/-5%)

ConvF

Channel X: 6.7 7%(K=2)
Channel Y: 6.7 7%(K=2)
Channel Z: 6.7 7%(K=2)

To minimize the uncertainty calculation all tissue sensitivity values were calculated using a load impedance of 5 MΩ.

Boundary Effect:

For a distance of 2.4mm the evaluated uncertainty (increase in the probe sensitivity) is less than 2%.

Page 9 of 10
This page has been reviewed for content and attested to on Page 2 of this document.

NCL Calibration Laboratories

Division of APREL Laboratories.

Test Equipment

The test equipment used during Probe Calibration, manufacturer, model number and, current calibration status are listed and located on the main APREL server R:\NCL\Calibration Equipment\Instrument List May 2011.

Page 10 of 10

This page has been reviewed for content and attested to on Page 2 of this document.

NCL CALIBRATION LABORATORIES

Calibration File No.: CP-1321

Client.: BACL

CERTIFICATE OF CALIBRATION

It is certified that the equipment identified below has been calibrated in the **NCL CALIBRATION LABORATORIES** by qualified personnel following recognized procedures and using transfer standards traceable to NRC/NIST.

Equipment: Miniature Isotropic RF Probe 1900 MHz

Manufacturer: APREL Laboratories

Model No.: E-020

Serial No.: 283

Calibration in Head Tissue

Calibration Procedure: SSI/DRB-TP-D01-032-E020-V2

Project No: BACB-E020-5732

Calibrated: 20th July 2011
Released on: 20th July 2011

This Calibration Certificate is Incomplete Unless Accompanied with the Calibration Results Summary

Released By: _____



NCL CALIBRATION LABORATORIES

51 SPECTRUM WAY
NEPEAN, ONTARIO
CANADA K2R 1E6

Division of APREL Lab.
TEL: (613) 820-4988
FAX: (613) 820-4161

NCL Calibration Laboratories

Division of APREL Laboratories.

Introduction

This Calibration Report reproduces the results of the calibration performed in line with the SSI/DRB-TP-D01-032-E020-V2 E-Field Probe Calibration Procedure. The results contained within this report are for APREL E-Field Probe E-020 283.

References

SSI/DRB-TP-D01-032-E020-V2 E-Field Probe Calibration Procedure
IEEE 1528 "Recommended Practice for Determining the Peak Spatial-Average Specific Absorption Rate (SAR) in the Human Body Due to Wireless Communications Devices: Experimental Techniques"
SSI-TP-011 Tissue Calibration Procedure

Conditions

Probe 283 was a re-calibration.

Ambient Temperature of the Laboratory: 22 °C +/- 0.5°C

Temperature of the Tissue: 21 °C +/- 0.5°C

We the undersigned attest that to the best of our knowledge the calibration of this probe has been accurately conducted and that all information contained within this report has been reviewed for accuracy.

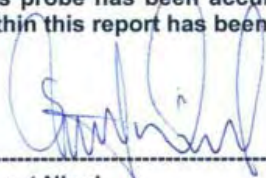

Stuart Nicol

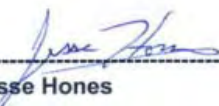

Jesse Hones

Page 2 of 10

This page has been reviewed for content and attested to on Page 2 of this document.

NCL Calibration Laboratories

Division of APREL Laboratories.

Calibration Results Summary

Probe Type:	E-Field Probe E-020
Serial Number:	283
Frequency:	1900 MHz
Sensor Offset:	1.56 mm
Sensor Length:	2.5 mm
Tip Enclosure:	Ertalyte*
Tip Diameter:	<5 mm
Tip Length:	60 mm
Total Length:	290 mm

*Resistive to recommended tissue recipes per IEEE-1528

Sensitivity in Air

Channel X:	1.2 $\mu\text{V}/(\text{V}/\text{m})^2$
Channel Y:	1.2 $\mu\text{V}/(\text{V}/\text{m})^2$
Channel Z:	1.2 $\mu\text{V}/(\text{V}/\text{m})^2$
Diode Compression Point:	95 mV

Page 3 of 10

This page has been reviewed for content and attested to on Page 2 of this document.

NCL Calibration Laboratories

Division of APREL Laboratories.

Sensitivity in Head Tissue Measured

Frequency: 1900 MHz

Epsilon: 38.91 (+/-5%) **Sigma:** 1.38 S/m (+/-5%)

ConvF

Channel X: 5.25

Channel Y: 5.25

Channel Z: 5.25

Tissue sensitivity values were calculated using the load impedance of the APREL Laboratories Daq-Paq.

Boundary Effect:

Uncertainty resulting from the boundary effect is less than 2% for the distance between the tip of the probe and the tissue boundary, when less than 2.44mm.

Spatial Resolution:

The measured probe tip diameter is 5 mm (+/- 0.01 mm) and therefore meets the requirements of SSI/DRB-TP-D01-032 for spatial resolution.

Page 4 of 10

This page has been reviewed for content and attested to on Page 2 of this document.

NCL Calibration Laboratories

Division of APREL Laboratories.

Receiving Pattern 1900 MHz (Air)

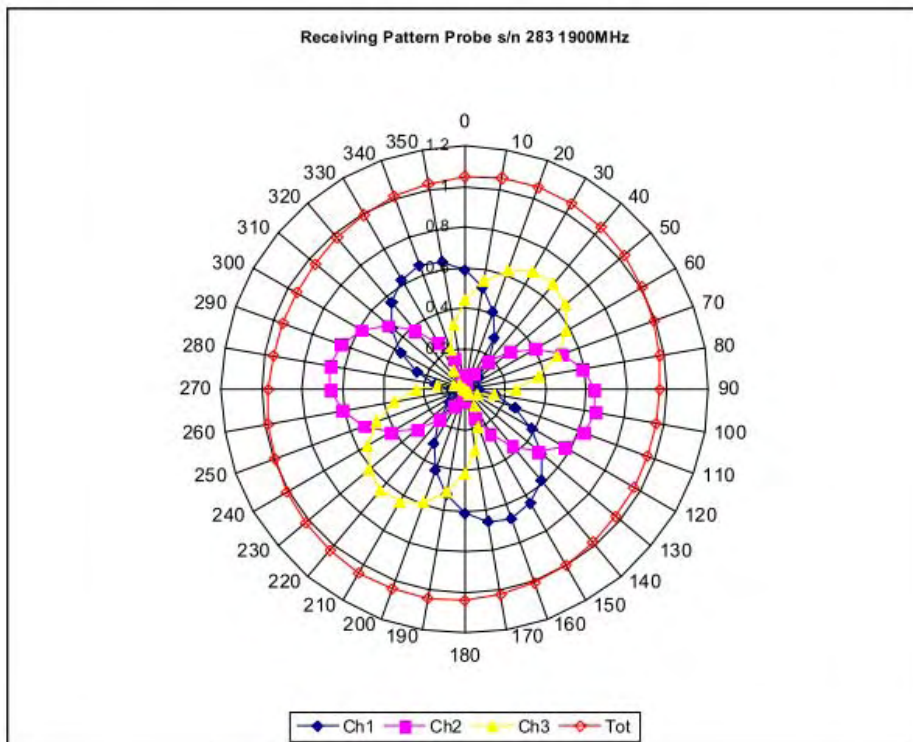

NCL Calibration Laboratories

Division of APREL Laboratories.

Isotropy Error 1900 MHz (Air)

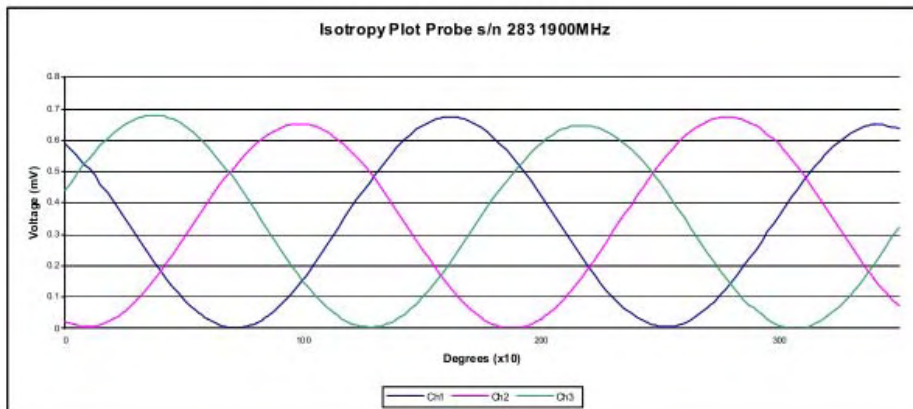
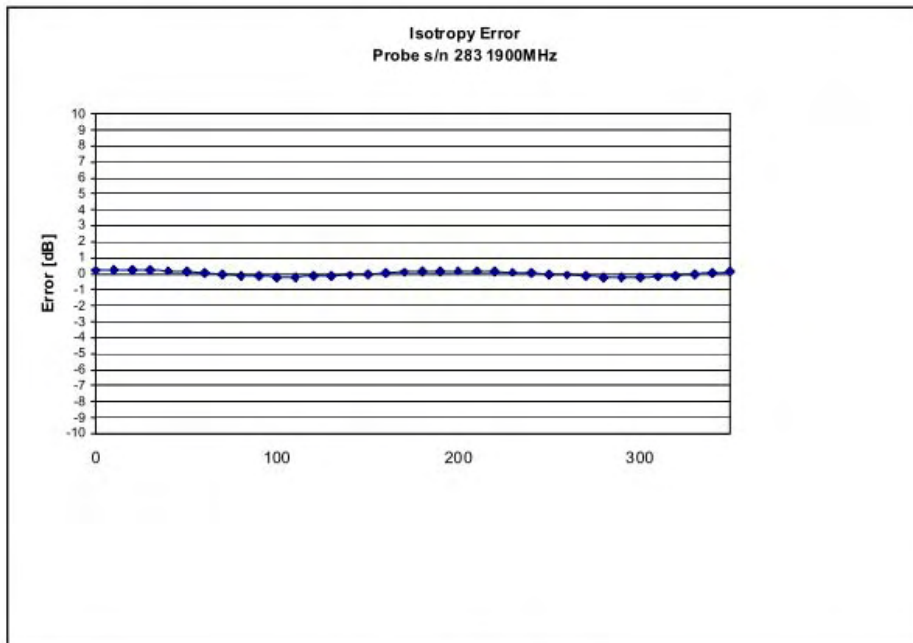

Isotropicity in Tissue: 0.10 dB

Page 6 of 10
This page has been reviewed for content and attested to on Page 2 of this document.

NCL Calibration Laboratories

Division of APREL Laboratories.

Dynamic Range

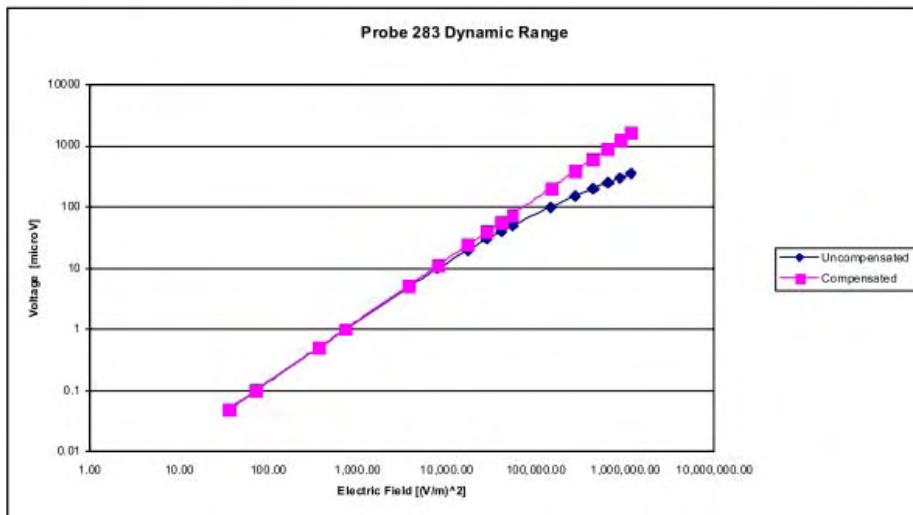

This page has been reviewed for content and attested to on Page 2 of this document.

NCL Calibration Laboratories

Division of APREL Laboratories.

Video Bandwidth

Probe Frequency Characteristics

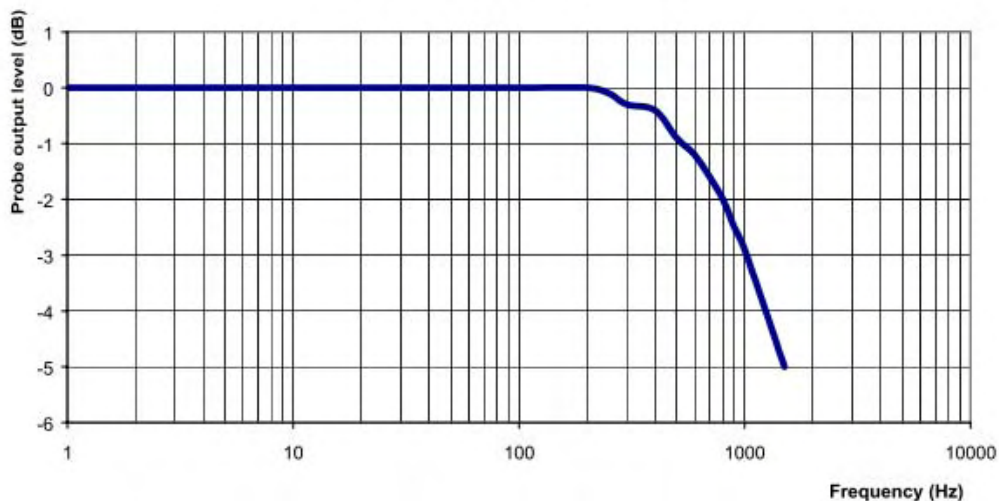

Video Bandwidth at 500 Hz 1 dB
Video Bandwidth at 1.02 KHz: 3 dB

NCL Calibration Laboratories

Division of APREL Laboratories.

Conversion Factor Uncertainty Assessment

Frequency: 1900MHz
Epsilon: 38.91 (+/-5%) **Sigma:** 1.38 S/m (+/-5%)

ConvF

Channel X: 5.25 7%(K=2)
Channel Y: 5.25 7%(K=2)
Channel Z: 5.25 7%(K=2)

To minimize the uncertainty calculation all tissue sensitivity values were calculated using a load impedance of 5 MΩ.

Boundary Effect:

For a distance of 2.4mm the evaluated uncertainty (increase in the probe sensitivity) is less than 2%.

Page 9 of 10

This page has been reviewed for content and attested to on Page 2 of this document.

NCL Calibration Laboratories

Division of APREL Laboratories.

Test Equipment

The test equipment used during Probe Calibration, manufacturer, model number and, current calibration status are listed and located on the main APREL server R:\NCL\Calibration Equipment\Instrument List May 2011.

Page 10 of 10

This page has been reviewed for content and attested to on Page 2 of this document.

NCL CALIBRATION LABORATORIES

Calibration File No.: CP-1322

Client.: BACL

CERTIFICATE OF CALIBRATION

It is certified that the equipment identified below has been calibrated in the **NCL CALIBRATION LABORATORIES** by qualified personnel following recognized procedures and using transfer standards traceable to NRC/NIST.

Equipment: Miniature Isotropic RF Probe 1900 MHz

Manufacturer: APREL Laboratories

Model No.: E-020

Serial No.: 283

Calibration in Body Tissue

Calibration Procedure: SSI/DRB-TP-D01-032-E020-V2

Project No: BACB-E020-5537

Calibrated: 20th July 2011

Released on: 20th July 2011

This Calibration Certificate is Incomplete Unless Accompanied with the Calibration Results Summary

Released By: _____

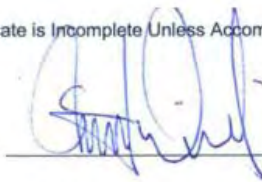

NCL CALIBRATION LABORATORIES

51 SPECTRUM WAY
NEPEAN, ONTARIO
CANADA K2R 1E6

Division of APREL Lab.
TEL: (613) 820-4988
FAX: (613) 820-4161

NCL Calibration Laboratories

Division of APREL Laboratories.

Introduction

This Calibration Report reproduces the results of the calibration performed in line with the SSI/DRB-TP-D01-032-E020-V2 E-Field Probe Calibration Procedure. The results contained within this report are for APREL E-Field Probe E-020 283.

References

SSI/DRB-TP-D01-032-E020-V2 E-Field Probe Calibration Procedure
IEEE 1528 "Recommended Practice for Determining the Peak Spatial-Average Specific Absorption Rate (SAR) in the Human Body Due to Wireless Communications Devices: Experimental Techniques"
SSI-TP-011 Tissue Calibration Procedure

Conditions

Probe 283 was a re-calibration.

Ambient Temperature of the Laboratory: 22 °C +/- 0.5°C
Temperature of the Tissue: 21 °C +/- 0.5°C

We the undersigned attest that to the best of our knowledge the calibration of this probe has been accurately conducted and that all information contained within this report has been reviewed for accuracy.

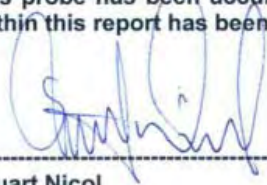
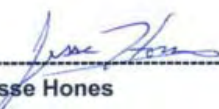
-----**Stuart Nicol**
-----**Jesse Hones**

Page 2 of 10

This page has been reviewed for content and attested to on Page 2 of this document.

NCL Calibration Laboratories

Division of APREL Laboratories.

Calibration Results Summary

Probe Type:	E-Field Probe E-020
Serial Number:	283
Frequency:	1900 MHz
Sensor Offset:	1.56 mm
Sensor Length:	2.5 mm
Tip Enclosure:	Ertalyte*
Tip Diameter:	<5 mm
Tip Length:	60 mm
Total Length:	290 mm

*Resistive to recommended tissue recipes per IEEE-1528

Sensitivity in Air

Channel X:	1.2 $\mu\text{V}/(\text{V}/\text{m})^2$
Channel Y:	1.2 $\mu\text{V}/(\text{V}/\text{m})^2$
Channel Z:	1.2 $\mu\text{V}/(\text{V}/\text{m})^2$
Diode Compression Point:	95 mV

Page 3 of 10
This page has been reviewed for content and attested to on Page 2 of this document.

NCL Calibration Laboratories

Division of APREL Laboratories.

Sensitivity in Body Tissue Measured

Frequency: 1900 MHz

Epsilon: 53.13 (+/-5%) **Sigma:** 1.55 S/m (+/-5%)

ConvF

Channel X: 5.15

Channel Y: 5.15

Channel Z: 5.15

Tissue sensitivity values were calculated using the load impedance of the APREL Laboratories Daq-Paq.

Boundary Effect:

Uncertainty resulting from the boundary effect is less than 2% for the distance between the tip of the probe and the tissue boundary, when less than 2.44mm.

Spatial Resolution:

The measured probe tip diameter is 5 mm (+/- 0.01 mm) and therefore meets the requirements of SSI/DRB-TP-D01-032 for spatial resolution.

Page 4 of 10
This page has been reviewed for content and attested to on Page 2 of this document.

NCL Calibration Laboratories

Division of APREL Laboratories.

Receiving Pattern 1900 MHz (Air)

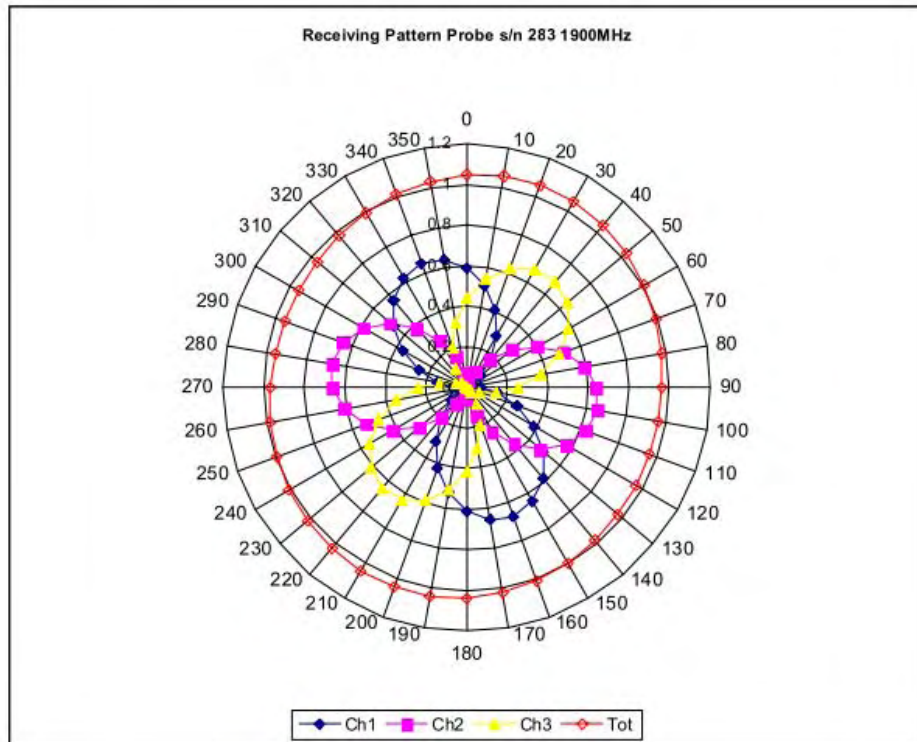

Page 5 of 10

This page has been reviewed for content and attested to on Page 2 of this document.

NCL Calibration Laboratories

Division of APREL Laboratories.

Isotropy Error 1900 MHz (Air)

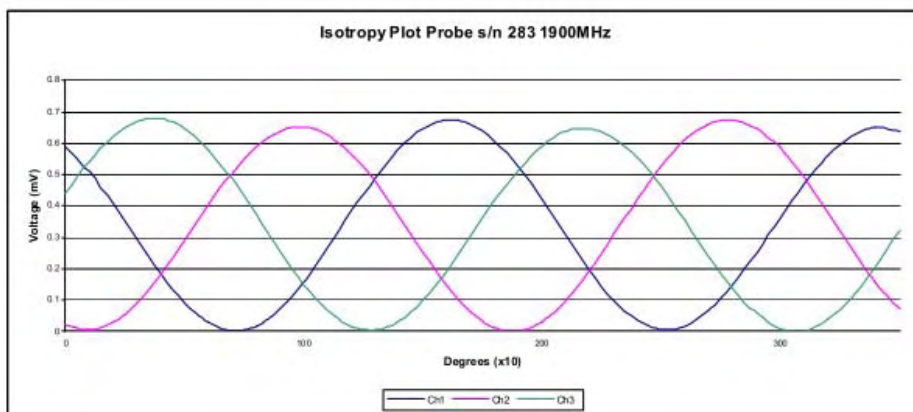
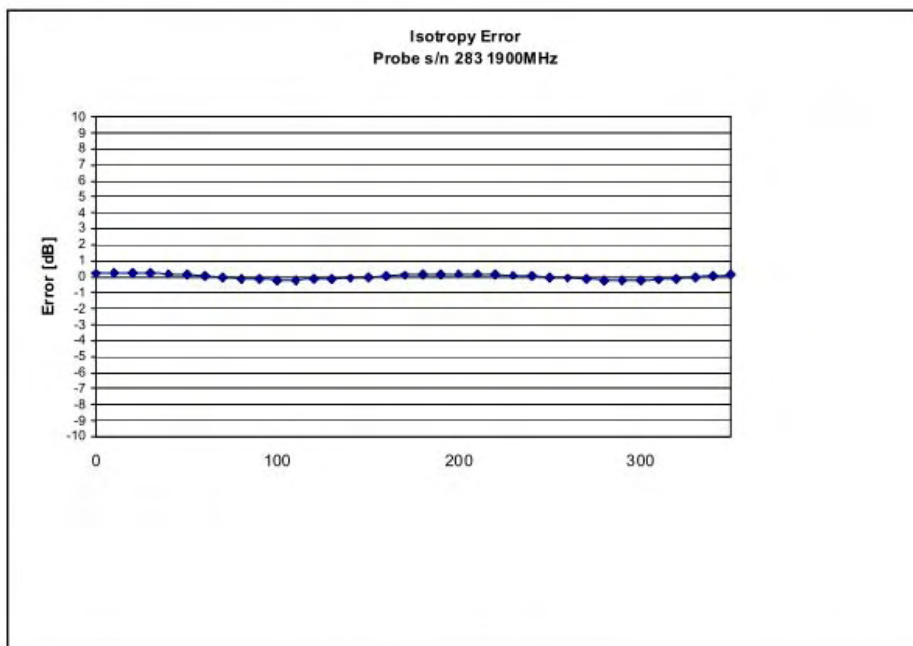

Isotropicity in Tissue: 0.10 dB

Page 6 of 10
This page has been reviewed for content and attested to on Page 2 of this document.

NCL Calibration Laboratories

Division of APREL Laboratories.

Dynamic Range

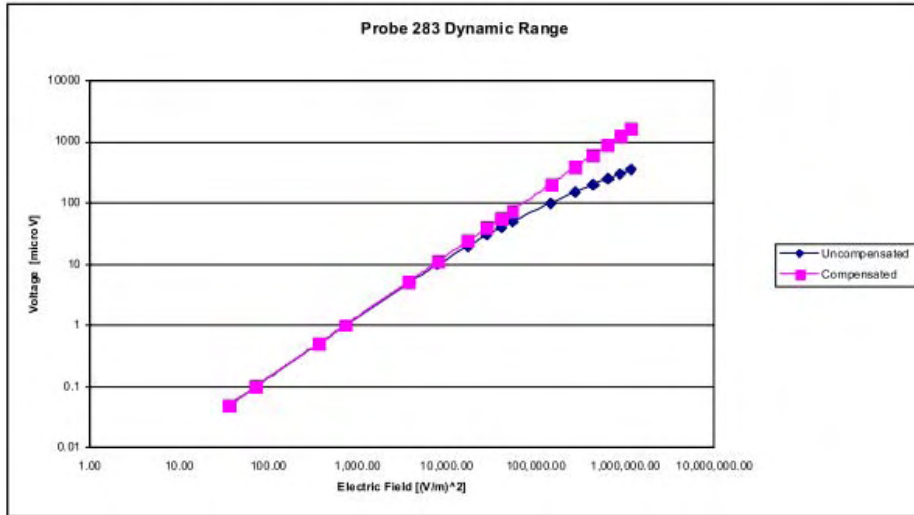

NCL Calibration Laboratories

Division of APREL Laboratories.

Video Bandwidth

Probe Frequency Characteristics

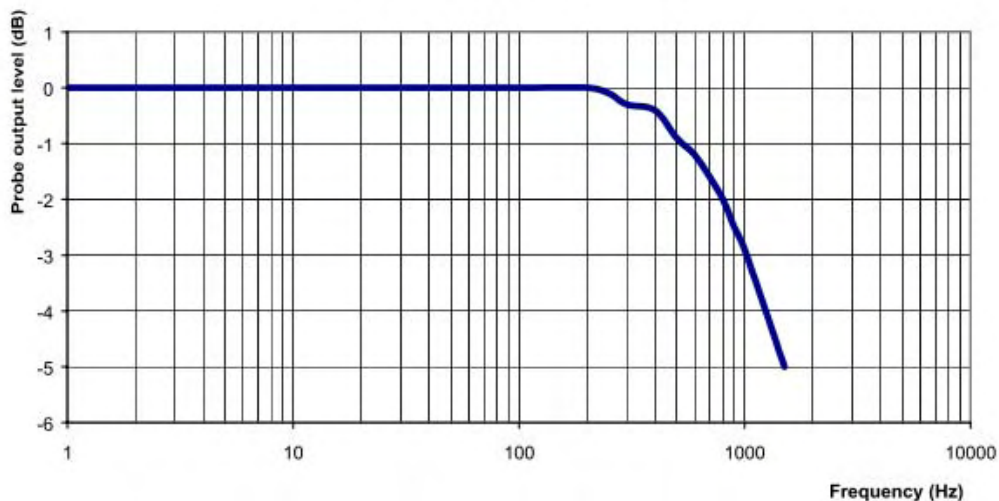

Video Bandwidth at 500 Hz 1 dB
Video Bandwidth at 1.02 KHz: 3 dB

NCL Calibration Laboratories

Division of APREL Laboratories.

Conversion Factor Uncertainty Assessment

Frequency: 1900MHz
Epsilon: 53.13 (+/-5%) **Sigma:** 1.55 S/m (+/-5%)

ConvF

Channel X: 5.15 7%(K=2)
Channel Y: 5.15 7%(K=2)
Channel Z: 5.15 7%(K=2)

To minimize the uncertainty calculation all tissue sensitivity values were calculated using a load impedance of 5 MΩ.

Boundary Effect:

For a distance of 2.4mm the evaluated uncertainty (increase in the probe sensitivity) is less than 2%.

Page 9 of 10
 This page has been reviewed for content and attested to on Page 2 of this document.

NCL Calibration Laboratories

Division of APREL Laboratories.

Test Equipment

The test equipment used during Probe Calibration, manufacturer, model number and, current calibration status are listed and located on the main APREL server R:\NCL\Calibration Equipment\Instrument List May 2011.

Page 10 of 10

This page has been reviewed for content and attested to on Page 2 of this document.

APPENDIX C – DIPOLE CALIBRATION CERTIFICATES

NCL CALIBRATION LABORATORIES

Calibration File No: DC-1176
Project Number: BACB-5547

CERTIFICATE OF CALIBRATION

It is certified that the equipment identified below has been calibrated in the
NCL CALIBRATION LABORATORIES by qualified personnel following recognized
procedures and using transfer standards traceable to NRC/NIST.

Validation Dipole

Manufacturer: APREL Laboratories
Part number: ALS-D-835-S-2
Frequency: 835 MHz
Serial No: 210-00564

Customer: Bay Area Compliance Laboratory

Calibrated: 4th November 2010
Released on: 5th November 2010

This Calibration Certificate is Incomplete Unless Accompanied with the Calibration Results Summary

Released By: _____

NCL CALIBRATION LABORATORIES

51 SPECTRUM WAY
NEPEAN, ONTARIO
CANADA K2R 1E6

Division of APREL Lab.
TEL: (613) 820-1900
FAX: (613) 820-4162

NCL Calibration Laboratories

Division of APREL Laboratories.

Conditions

Dipole 210-00564 was new and taken from stock prior to calibration.

Ambient Temperature of the Laboratory: 22 °C +/- 0.5°C

Temperature of the Tissue: 21 °C +/- 0.5°C

We the undersigned attest that to the best of our knowledge the calibration of this device has been accurately conducted and that all information contained within this report has been reviewed for accuracy.



Stuart Nicol



C. Teodorian

This page has been reviewed for content and attested to by signature within this document.

NCL Calibration Laboratories

Division of APREL Laboratories.

Calibration Results Summary

The following results relate the Calibrated Dipole and should be used as a quick reference for the user.

Mechanical Dimensions

Length: 162.2 mm
Height: 89.4 mm

Electrical Specification

SWR: 1.085 U
Return Loss: -29.149 dB
Impedance: 50.605 Ω

System Validation Results

Frequency	1 Gram	10 Gram	Peak
835 MHz	9.51	6.15	14.19

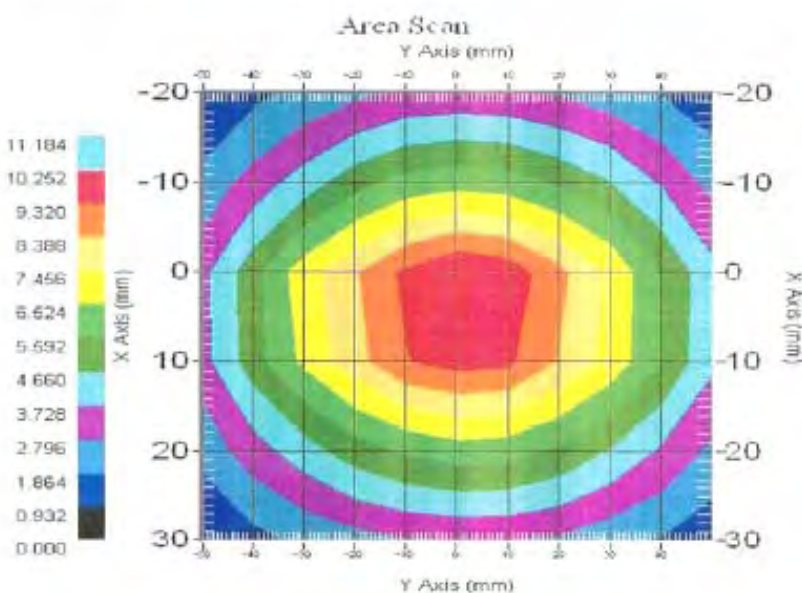

This page has been reviewed for content and attested to by signature within this document.

NCL Calibration Laboratories

Division of APREL Laboratories.

Introduction

This Calibration Report has been produced in line with the SSI Dipole Calibration Procedure SSI-TP-018-ALSAS. The results contained within this report are for Validation Dipole 210-00564. The calibration routine consisted of a three-step process. Step 1 was a mechanical verification of the dipole to ensure that it meets the mechanical specifications. Step 2 was an Electrical Calibration for the Validation Dipole, where the SWR, Impedance, and the Return loss were assessed. Step 3 involved a System Validation using the ALSAS-10U, along with APREL E-020 130 MHz to 26 GHz E-Field Probe Serial Number 212.

References

SSI-TP-018-ALSAS Dipole Calibration Procedure
SSI-TP-016 Tissue Calibration Procedure
IEEE 1528 "Recommended Practice for Determining the Peak Spatial-Average Specific Absorption Rate (SAR) in the Human Body Due to Wireless Communications Devices: Experimental Techniques"

Conditions

Dipole 210-00564 was new taken from stock.

Ambient Temperature of the Laboratory: 22 °C +/- 0.5°C
Temperature of the Tissue: 20 °C +/- 0.5°C

This page has been reviewed for content and attested to by signature within this document.

4

NCL Calibration Laboratories

Division of APREL Laboratories.

Dipole Calibration Results

Mechanical Verification

APREL Length	APREL Height	Measured Length	Measured Height
161.0 mm	89.8 mm	162.2 mm	89.4 mm

Tissue Validation

Head Tissue 835MHz	Measured
Dielectric constant, ϵ_r	41.10
Conductivity, σ [S/m]	0.91

This page has been reviewed for content and attested to by signature within this document.

NCL Calibration Laboratories

Division of APREL Laboratories.

Electrical Calibration

Test	Result
S11 RL	-29.149 dB
SWR	1.085 U
Impedance	50.605 Ω

The Following Graphs are the results as displayed on the Vector Network Analyzer.

S11 Parameter Return Loss

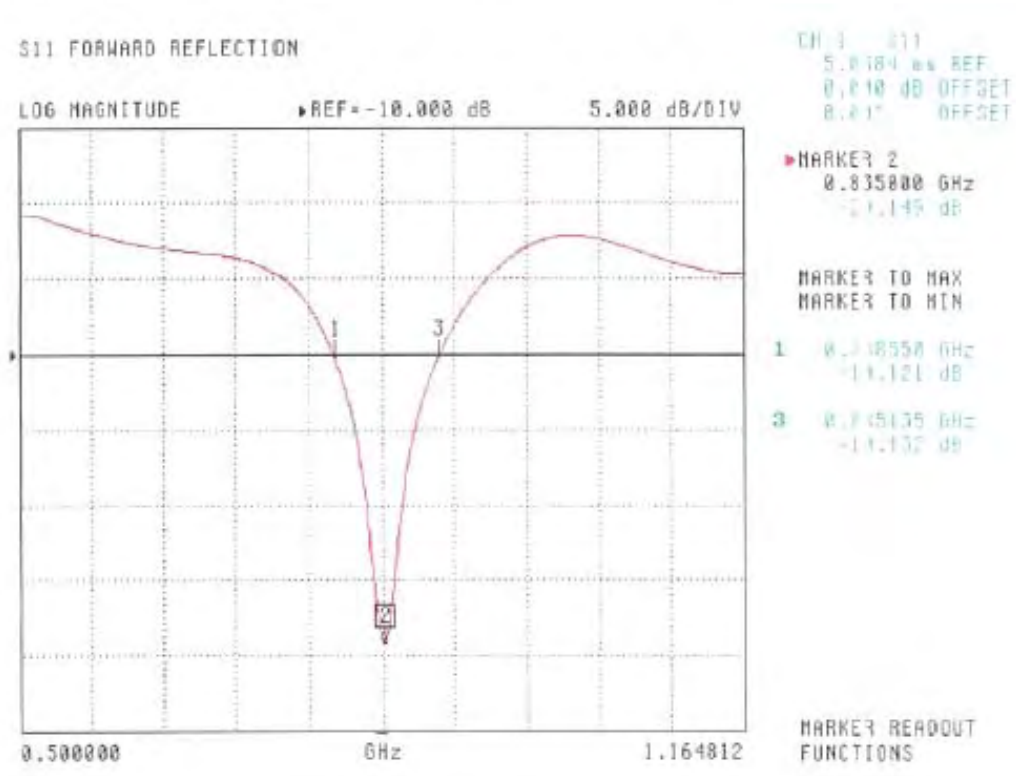

This page has been reviewed for content and attested to by signature within this document.

NCL Calibration Laboratories

Division of APREL Laboratories.

SWR

S11 FORWARD REFLECTION

SWR REF=172.168 mU 2.000 U/DIV

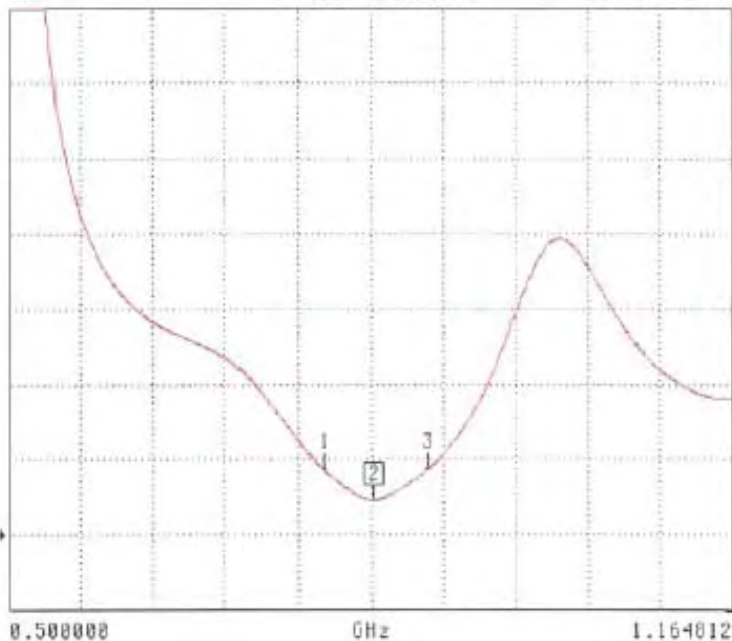

CH 1 S11
5.0184 mV REF
0.010 dB OFFSET
0.01" OFFSET

MARKER 2
0.835000 GHz
1.085 U

MARKER TO MAX
MARKER TO MIN

1 0.718550 GHz
1.932 U

3 0.951135 GHz
1.924 U

MARKER READOUT
FUNCTIONS

This page has been reviewed for content and attested to by signature within this document.

NCL Calibration Laboratories

Division of APREL Laboratories.

Smith Chart Dipole Impedance

S11 FORWARD REFLECTION
IMPEDANCE

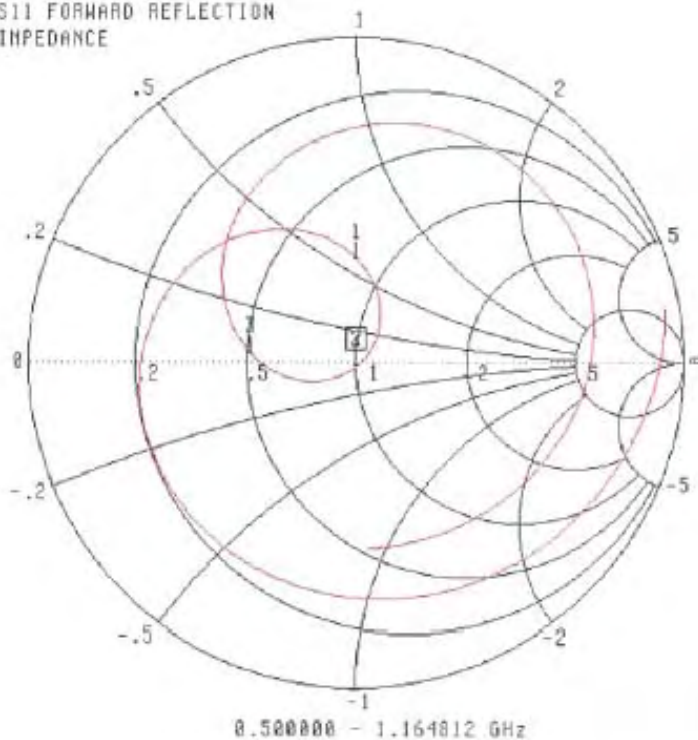

CH 1 = S11
5.0154 dB REF
0.01M dB OFFSET
0.011 OFFSET

MARKER 2
0.835000 GHz
51.685 Ω
-1.513 j Ω

MARKER TO MAX
MARKER TO MIN

1 0.718550 GHz
4.410 Ω
3.000 j Ω
3 0.815135 GHz
2.147 Ω
1.505 j Ω

MARKER READOUT
FUNCTIONS

This page has been reviewed for content and attested to by signature within this document.

NCL Calibration Laboratories

Division of APREL Laboratories.

System Validation Results Using the Electrically Calibrated Dipole

Head Tissue Frequency	1 Gram	10 Gram	Peak Above Feed Point
835 MHz	9.51	6.15	14.19

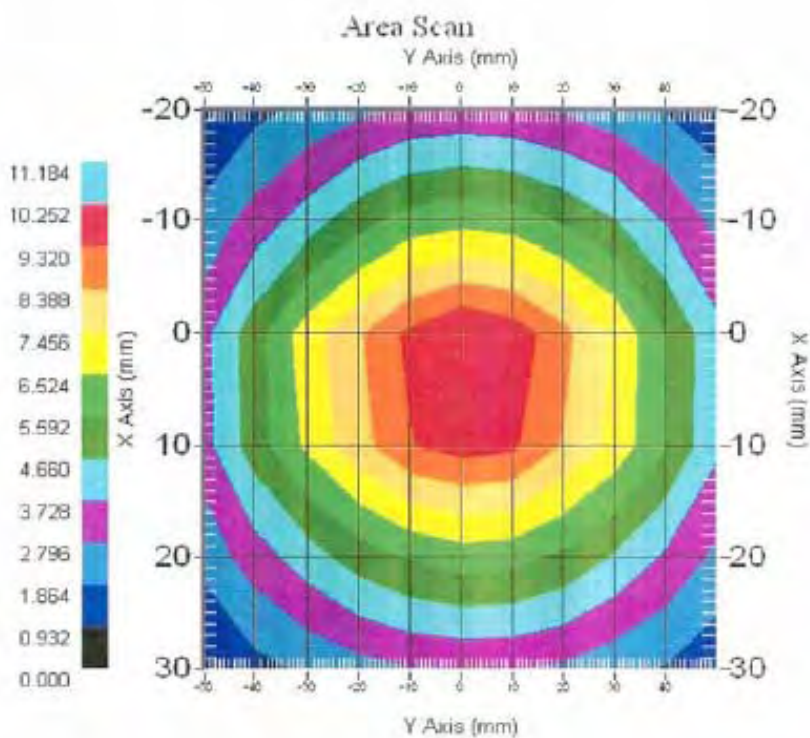

This page has been reviewed for content and attested to by signature within this document.

NCL Calibration Laboratories

Division of APREL Laboratories.

Test Equipment

The test equipment used during Probe Calibration, manufacturer, model number and, current calibration status are listed and located on the main APREL server R:\NCL\Calibration Equipment\Instrument List 2010.

This page has been reviewed for content and attested to by signature within this document.

10

NCL CALIBRATION LABORATORIES

Calibration File No: DC-1177
Project Number: BACB-5548

CERTIFICATE OF CALIBRATION

It is certified that the equipment identified below has been calibrated in the **NCL CALIBRATION LABORATORIES** by qualified personnel following recognized procedures and using transfer standards traceable to NRC/NIST.

Validation Dipole

Manufacturer: APREL Laboratories
Part number: ALS-D-1900-S-2
Frequency: 1900 MHz
Serial No: 210-00715

Customer: Bay Area Compliance Laboratory

Calibrated: 4th November 2010
Released on: 5th November 2010

This Calibration Certificate is Incomplete Unless Accompanied with the Calibration Results Summary

Released By: _____

NCL CALIBRATION LABORATORIES

51 SPECTRUM WAY
NEPEAN, ONTARIO
CANADA K2R 1E5

Division of APREL Lab.
TEL: (613) 820-4988
FAX: (613) 820-4162

NCL Calibration Laboratories

Division of APREL Laboratories.

Conditions

Dipole 210-00715 was new and taken from stock prior to calibration.

Ambient Temperature of the Laboratory: 22 °C +/- 0.5°C

Temperature of the Tissue: 21 °C +/- 0.5°C

We the undersigned attest that to the best of our knowledge the calibration of this device has been accurately conducted and that all information contained within this report has been reviewed for accuracy.



Stuart Nicol



C. Teodorian

This page has been reviewed for content and attested to by signature within this document.

NCL Calibration Laboratories

Division of APREL Laboratories.

Calibration Results Summary

The following results relate the Calibrated Dipole and should be used as a quick reference for the user.

Mechanical Dimensions

Length: 67.1 mm

Height: 38.9 mm

Electrical Specification

SWR: 1.081 U

Return Loss: -29.769 dB

Impedance: 50.034 Ω

System Validation Results

Frequency	1 Gram	10 Gram	Peak
1900 MHz	38.9	20.4	69.8

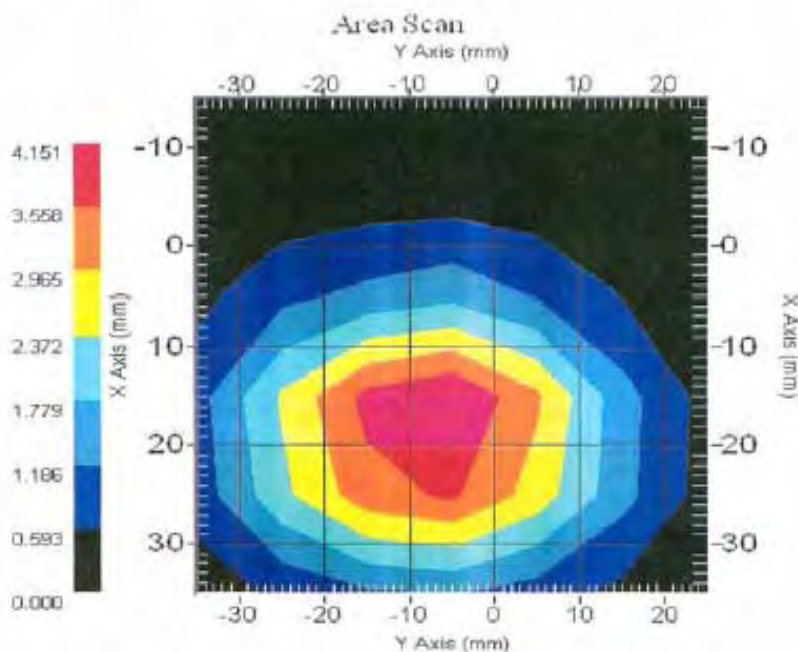

This page has been reviewed for content and attested to by signature within this document.

NCL Calibration Laboratories

Division of APREL Laboratories.

Introduction

This Calibration Report has been produced in line with the SSI Dipole Calibration Procedure SSI-TP-018-ALSAS. The results contained within this report are for Validation Dipole 210-00715. The calibration routine consisted of a three-step process. Step 1 was a mechanical verification of the dipole to ensure that it meets the mechanical specifications. Step 2 was an Electrical Calibration for the Validation Dipole, where the SWR, Impedance, and the Return loss were assessed. Step 3 involved a System Validation using the ALSAS-10U, along with APREL E-020 130 MHz to 26 GHz E-Field Probe Serial Number 212.

References

SSI-TP-018-ALSAS Dipole Calibration Procedure
SSI-TP-016 Tissue Calibration Procedure
IEEE 1528 "Recommended Practice for Determining the Peak Spatial-Average Specific Absorption Rate (SAR) in the Human Body Due to Wireless Communications Devices: Experimental Techniques"

Conditions

Dipole 210-00715 was new taken from stock.

Ambient Temperature of the Laboratory: 22 °C +/- 0.5°C
Temperature of the Tissue: 20 °C +/- 0.5°C

This page has been reviewed for content and attested to by signature within this document.

4

NCL Calibration Laboratories

Division of APREL Laboratories.

Dipole Calibration Results

Mechanical Verification

APREL Length	APREL Height	Measured Length	Measured Height
68.0 mm	39.5 mm	67.1mm	38.9 mm

Tissue Validation

Head Tissue 1900 MHz	Measured
Dielectric constant, ϵ_r	40.09
Conductivity, σ [S/m]	1.39

This page has been reviewed for content and attested to by signature within this document.

5

NCL Calibration Laboratories

Division of APREL Laboratories.

Electrical Calibration

Test	Result
S11 R/L	-29.769 dB
SWR	1.081 U
Impedance	50.034 Ω

The Following Graphs are the results as displayed on the Vector Network Analyzer.

S11 Parameter Return Loss

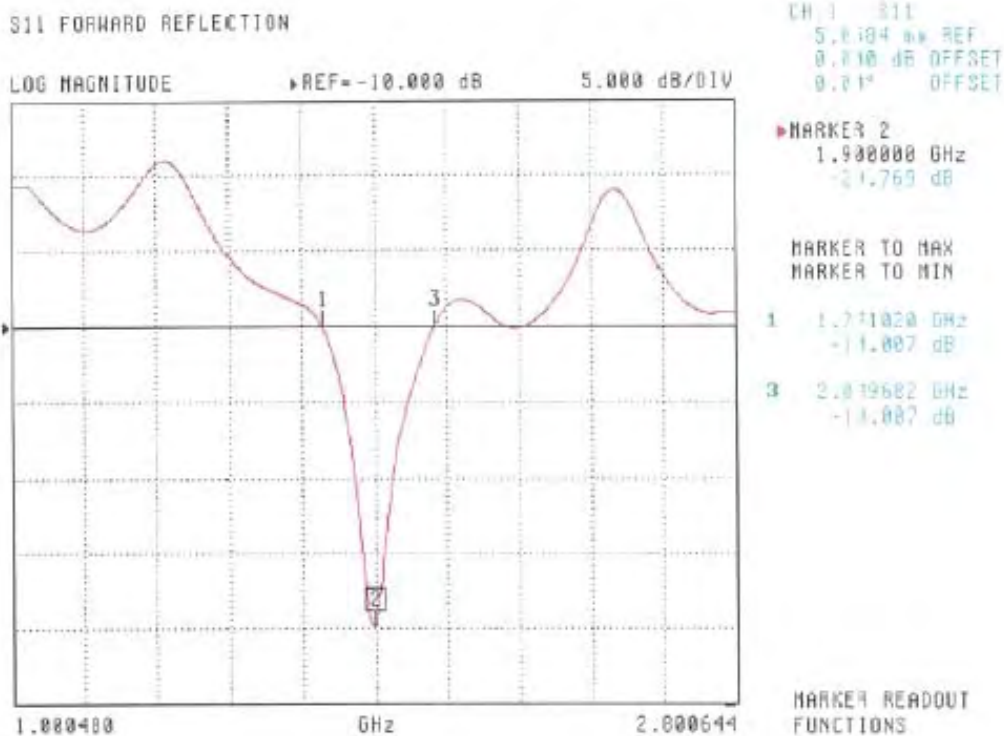

This page has been reviewed for content and attested to by signature within this document.

NCL Calibration Laboratories

Division of APREL Laboratories.

SWR

S11 FORWARD REFLECTION

SWR REF=172.168 mU 2.000 U/DIV

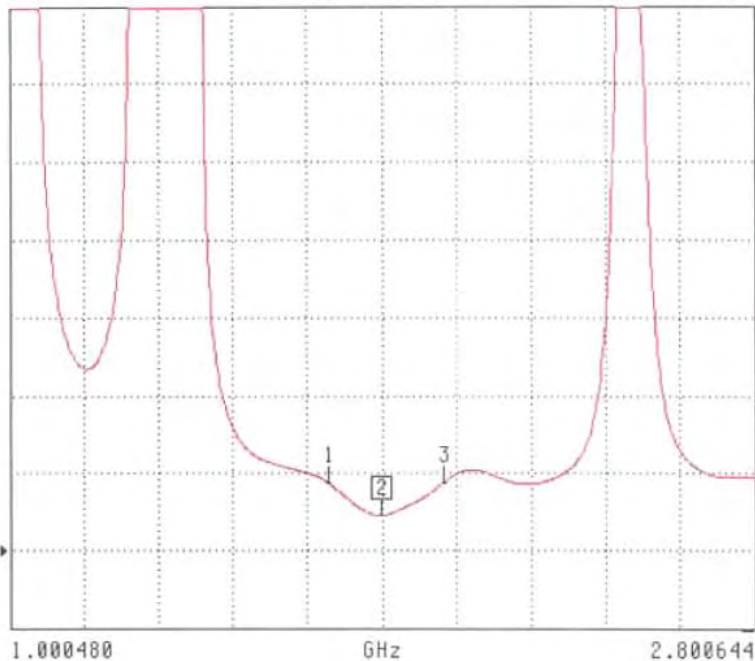

CH 1 -- S11
5.0184 mV REF
0.010 dB OFFSET
0.01° OFFSET

MARKER 2
1.900000 GHz
1.001 U

MARKER TO MAX
MARKER TO MIN

1 1.711020 GHz
1.939 U

3 2.019682 GHz
1.942 U

MARKER READOUT
FUNCTIONS

This page has been reviewed for content and attested to by signature within this document.

NCL Calibration Laboratories

Division of APREL Laboratories.

Smith Chart Dipole Impedance

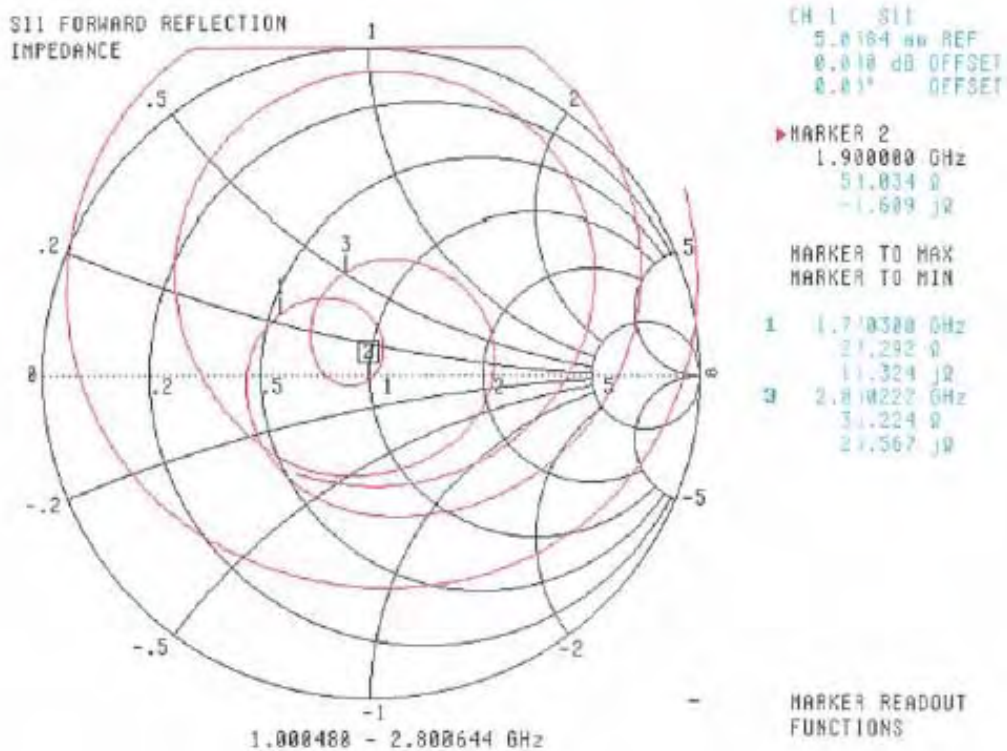

This page has been reviewed for content and attested to by signature within this document.

NCL Calibration Laboratories

Division of APREL Laboratories.

System Validation Results Using the Electrically Calibrated Dipole

Head Tissue Frequency	1 Gram	10 Gram	Peak Above Feed Point
1900 MHz	38.9	20.4	69.8

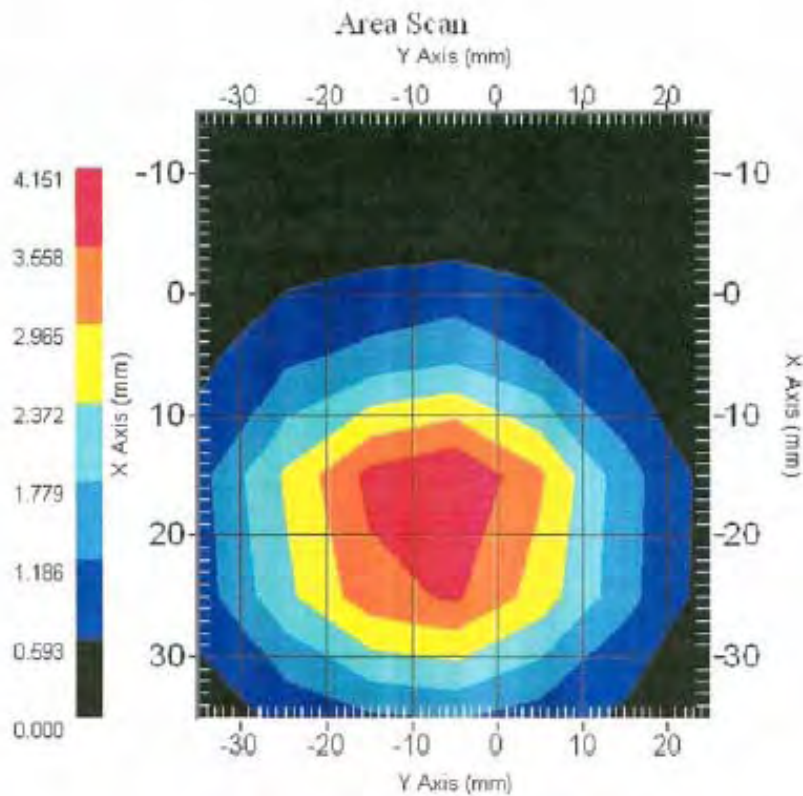

This page has been reviewed for content and attested to by signature within this document.

NCL Calibration Laboratories

Division of APREL Laboratories.

Test Equipment

The test equipment used during Probe Calibration, manufacturer, model number and, current calibration status are listed and located on the main APREL server R:\NCL\Calibration Equipment\Instrument List 2010.

This page has been reviewed for content and attested to by signature within this document.

10

APPENDIX D – EUT TEST POSITION PHOTOS

Liquid depth ≥ 15 cm

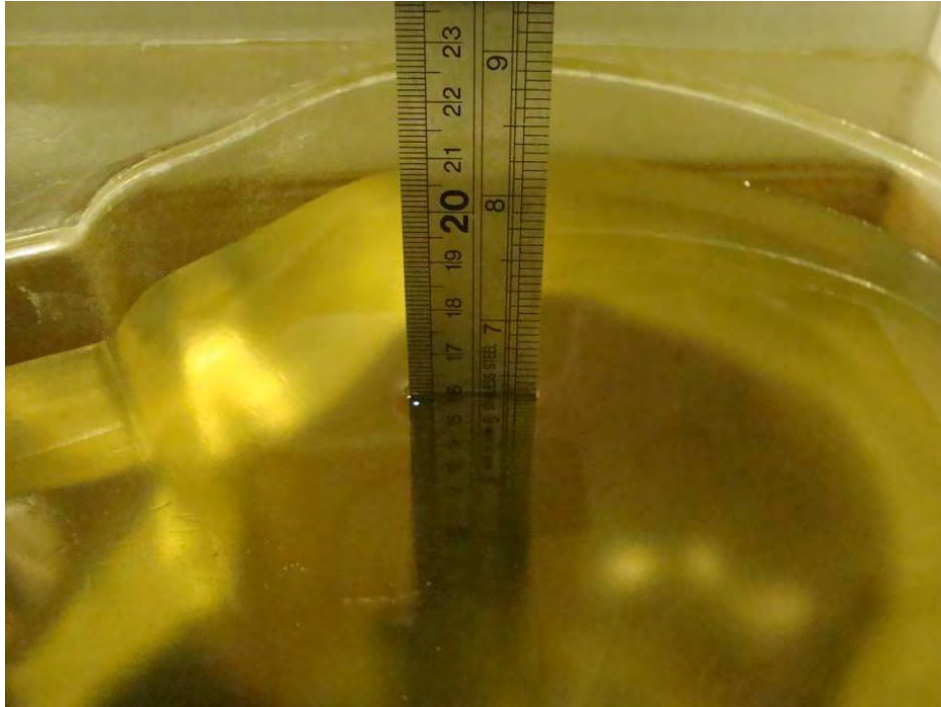

Body-worn Back Setup Photo (keypad closed)

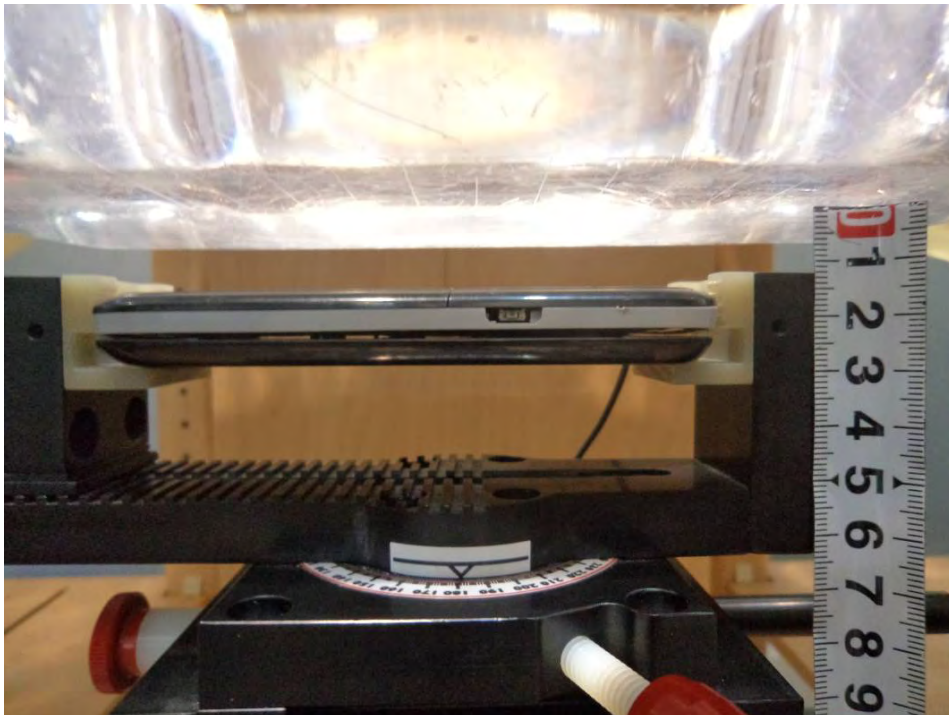

Left Head Touch Setup Photo (keypad closed)

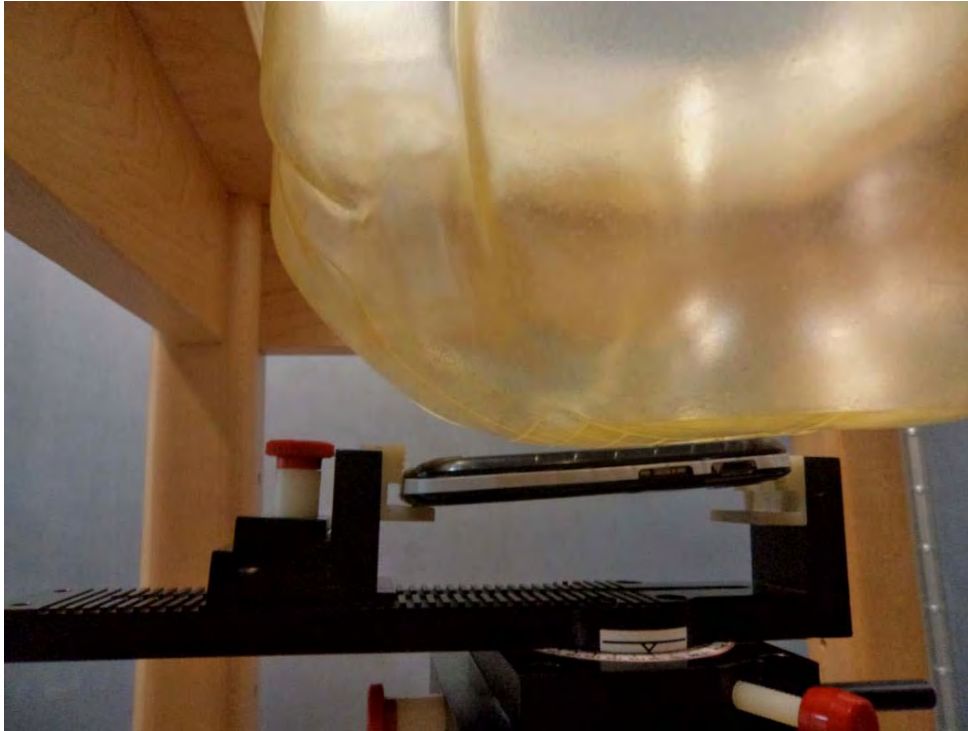

Left Head Tilt Setup Photo (keypad closed)



Right Head Touch Setup Photo (keypad closed)

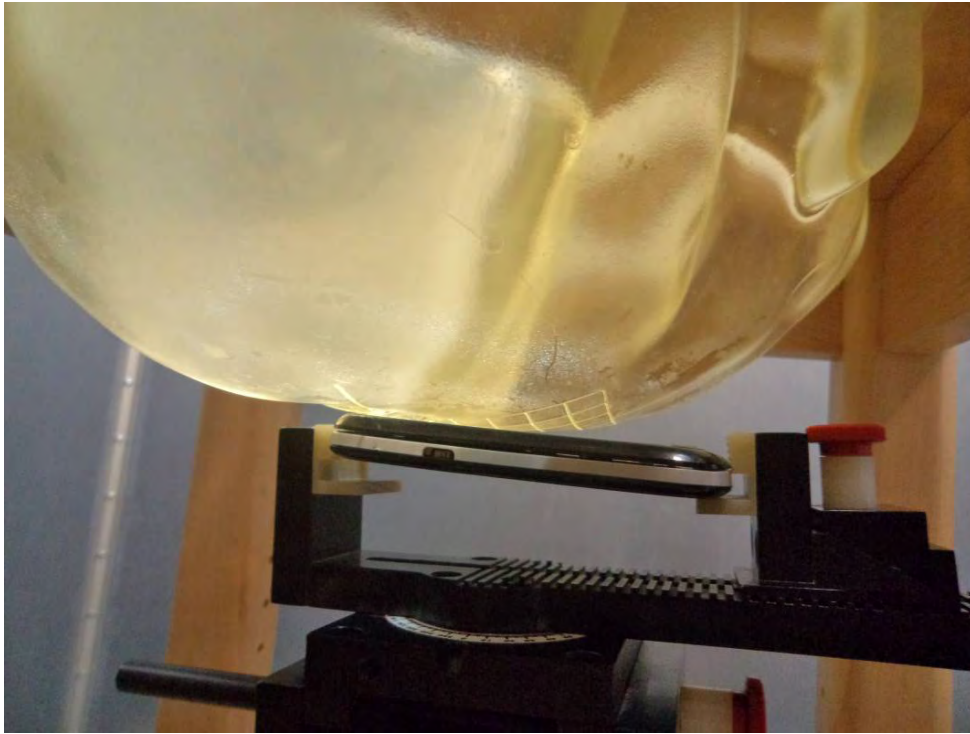

Right Head Tilt Setup Photo (keypad closed)

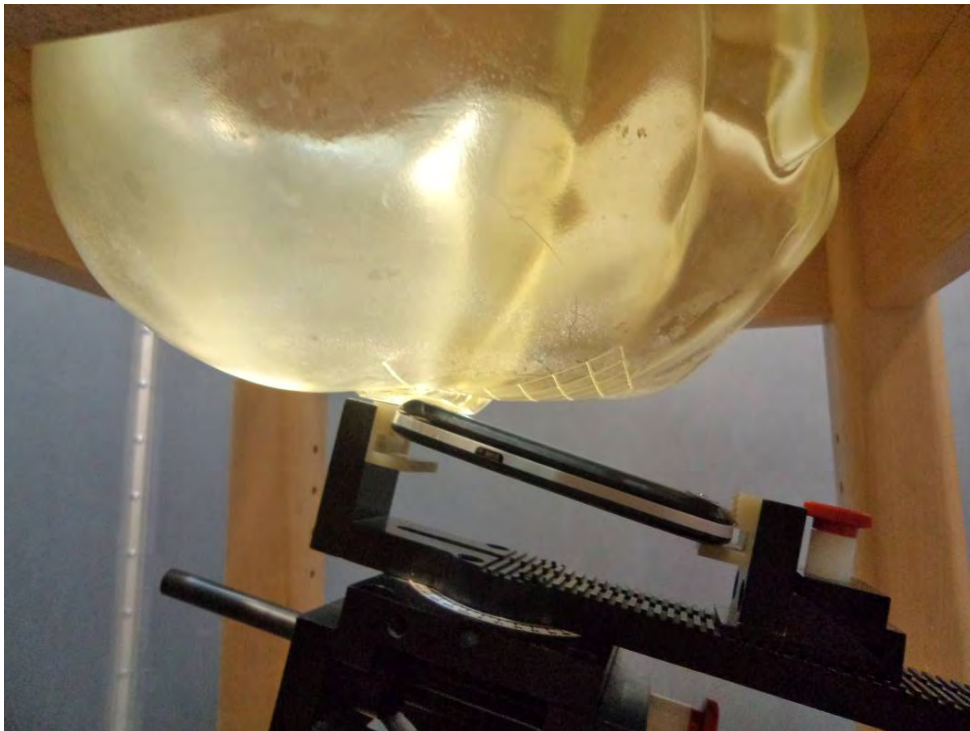

Body-worn Back Setup Photo (keypad opened)

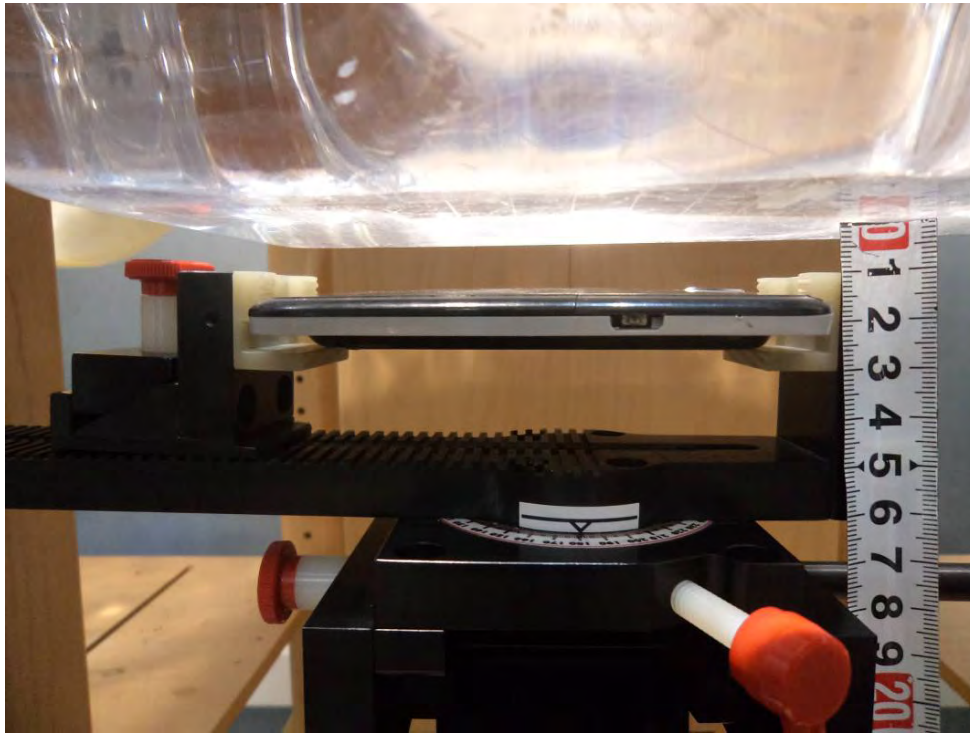

Left Head Touch Setup Photo (keypad opened)



Left Head Tilt Setup Photo (keypad opened)

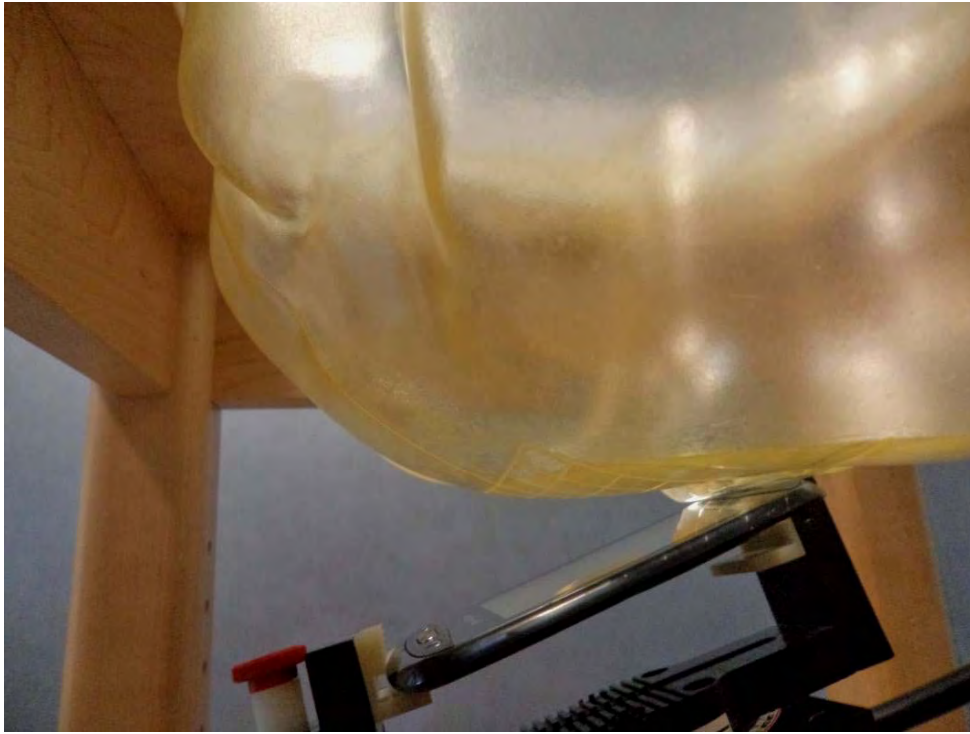

Right Head Touch Setup Photo (keypad opened)

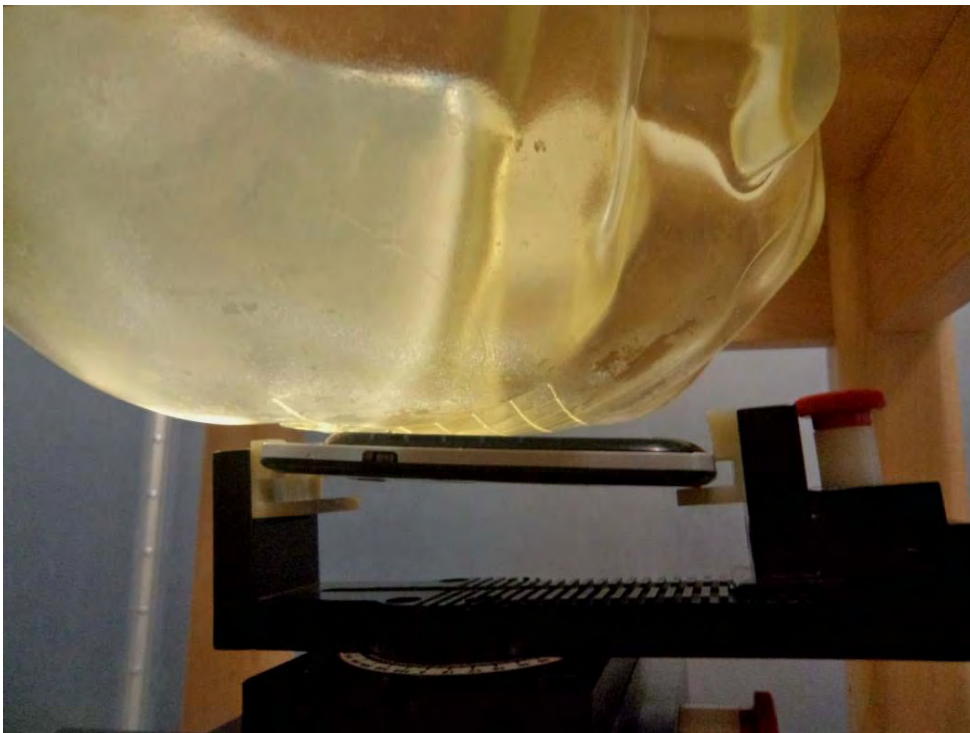

Right Head Tilt Setup Photo (keypad opened)

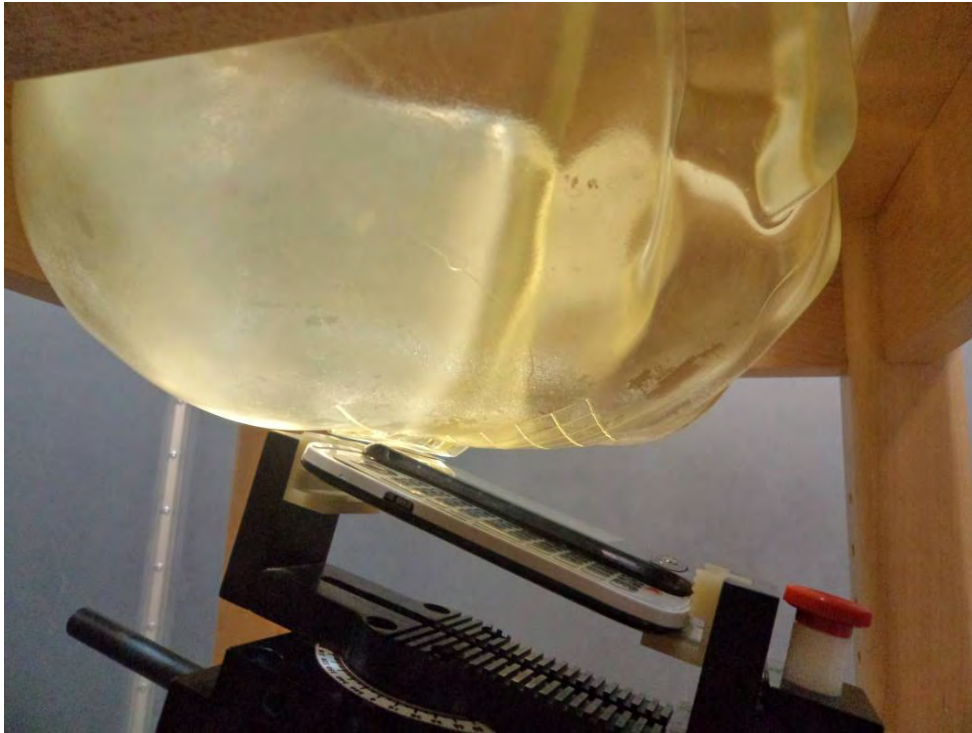

APPENDIX E – EUT PHOTOS

EUT – Front Side View (close keypad)



EUT – Back Side View (close keypad)



EUT – Front Side View (open keypad)



EUT – Front Side View (open keypad)



EUT – Uncovered View



EUT- Right Side View



EUT- Left Side View



EUT-Headset view



APPENDIX F - INFORMATIVE REFERENCES

- [1] Federal Communications Commission, \Report and order: Guidelines for evaluating the environmental effects of radiofrequency radiation", Tech. Rep. FCC 96-326, FCC, Washington, D.C. 20554, 1996.
- [2] David L. Means Kwok Chan, Robert F. Cleveland, \Evaluating compliance with FCC guidelines for human exposure to radiofrequency electromagnetic fields", Tech. Rep., Federal Communication Commission, Office of Engineering & Technology, Washington, DC, 1997.
- [3] Thomas Schmid, Oliver Egger, and Niels Kuster, \Automated E-field scanning system for dosimetric assessments", IEEE Transactions on Microwave Theory and Techniques, vol. 44, pp. 105{113, Jan. 1996.
- [4] Niels Kuster, Ralph Kastle, and Thomas Schmid, \Dosimetric evaluation of mobile communications equipment with known precision", IEEE Transactions on Communications, vol. E80-B, no. 5, pp. 645{652, May 1997.
- [5] CENELEC, \Considerations for evaluating of human exposure to electromagnetic fields (EMFs) from mobile telecommunication equipment (MTE) in the frequency range 30MHz - 6GHz", Tech. Rep., CENELEC, European Committee for Electrotechnical Standardization, Brussels, 1997.
- [6] ANSI, ANSI/IEEE C95.1-1992: IEEE Standard for Safety Levels with Respect to Human Exposure to Radio Frequency Electromagnetic Fields, 3 kHz to 300 GHz, The Institute of Electrical and Electronics Engineers, Inc., New York, NY 10017, 1992.
- [7] Katja Pokovic, Thomas Schmid, and Niels Kuster, \Robust setup for precise calibration of E-field probes in tissue simulating liquids at mobile communications frequencies", in ICECOM _ 97, Dubrovnik, October 15{17, 1997, pp. 120-24.
- [8] Katja Pokovic, Thomas Schmid, and Niels Kuster, \E-field probe with improved isotropy in brain simulating liquids", in Proceedings of the ELMAR, Zadar, Croatia, 23{25 June, 1996, pp. 172-175.
- [9] Volker Hombach, Klaus Meier, Michael Burkhardt, Eberhard Kuhn, and Niels Kuster, \The dependence of EM energy absorption upon human head modeling at 900 MHz", IEEE Transactions on Microwave Theory and Techniques, vol. 44, no. 10, pp. 1865-1873, Oct. 1996.
- [10] Klaus Meier, Ralf Kastle, Volker Hombach, Roger Tay, and Niels Kuster, \The dependence of EM energy absorption upon human head modeling at 1800 MHz", IEEE Transactions on Microwave Theory and Techniques, Oct. 1997, in press.
- [11] W. Gander, Computermathematik, Birkhaeuser, Basel, 1992.
- [12] W. H. Press, S. A. Teukolsky, W. T. Vetterling, and B. P. Flannery, Numerical Recipes in C, The Art of Scientific Computing, Second Edition, Cambridge University Press, 1992. Dosimetric Evaluation of Sample device, month 1998 9
- [13] NIS81 NAMAS, \The treatment of uncertainty in EMC measurement", Tech. Rep., NAMAS Executive, National Physical Laboratory, Teddington, Middlesex, England, 1994.
- [14] Barry N. Taylor and Christ E. Kuyatt, \Guidelines for evaluating and expressing the uncertainty of NIST measurement results", Tech. Rep., National Institute of Standards and Technology, 1994. Dosimetric Evaluation of Sample device, month 1998 10.

***** END OF REPORT *****