

一、 Receiver operation

The frequency ranges of the synthesizer for RX mode are

RX mode	GSM850	869M -894M
	PCS	1930M-1990M

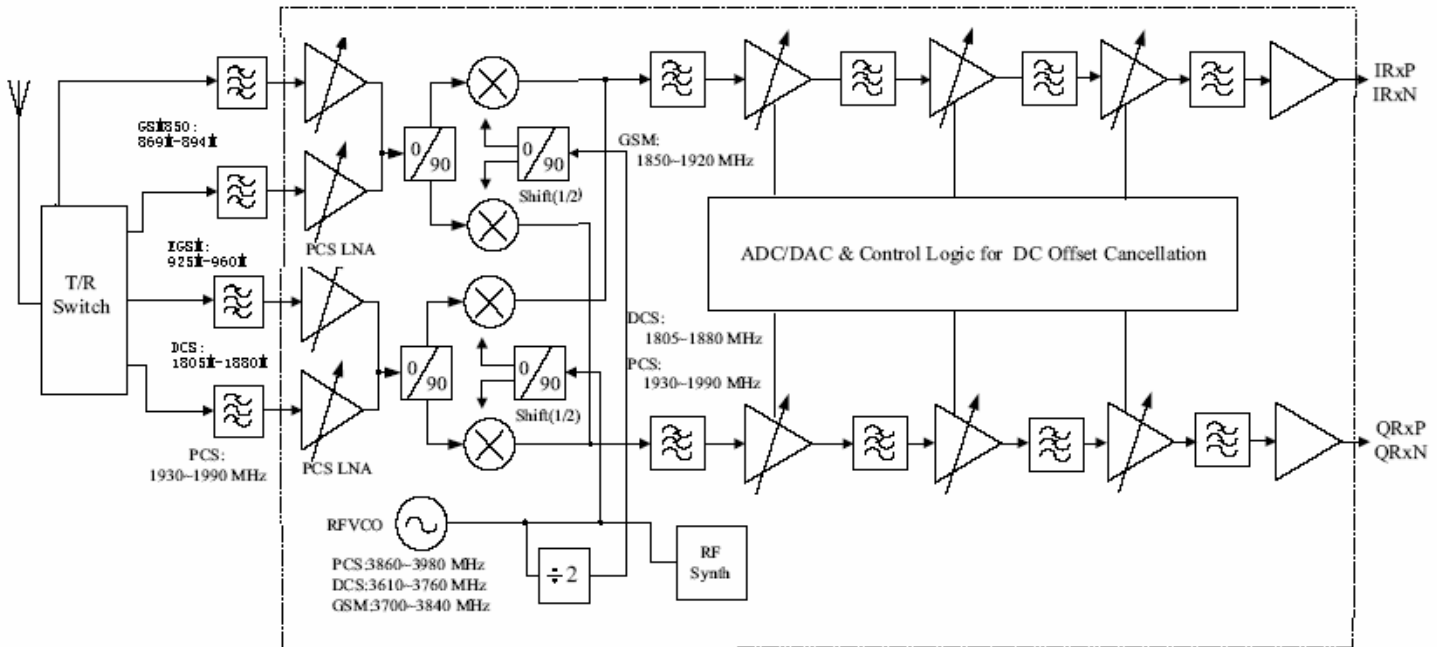

The Receiver structure in SKY77517 is a very-low IF solution. More than 100DB gain, more than 110DB control range. And by the way, all of the DC-offset canceling processes are done within chip. we do not have to care about that.

The LNA amplifies the RF signal after passing the T/R switch and RF SAW filter and before it enters the down-converter section. The RF signal is mixed with a local oscillator(LO) signal to generate the baseband signal.

Four LPFs are used in the baseband signal processing for reduce block signals. The first LPF employs two external capacitors, and we can check whether the front-end (LNA+MIXer) is functionally well or not by probing these two capacitors to see if there is any baseband signal(<200kHz).

After three stages of DC-offset canceling,the signal(I+/I-/Q+/Q-) then output to the baseband IC for further processing.

二、 Transmitter Operation

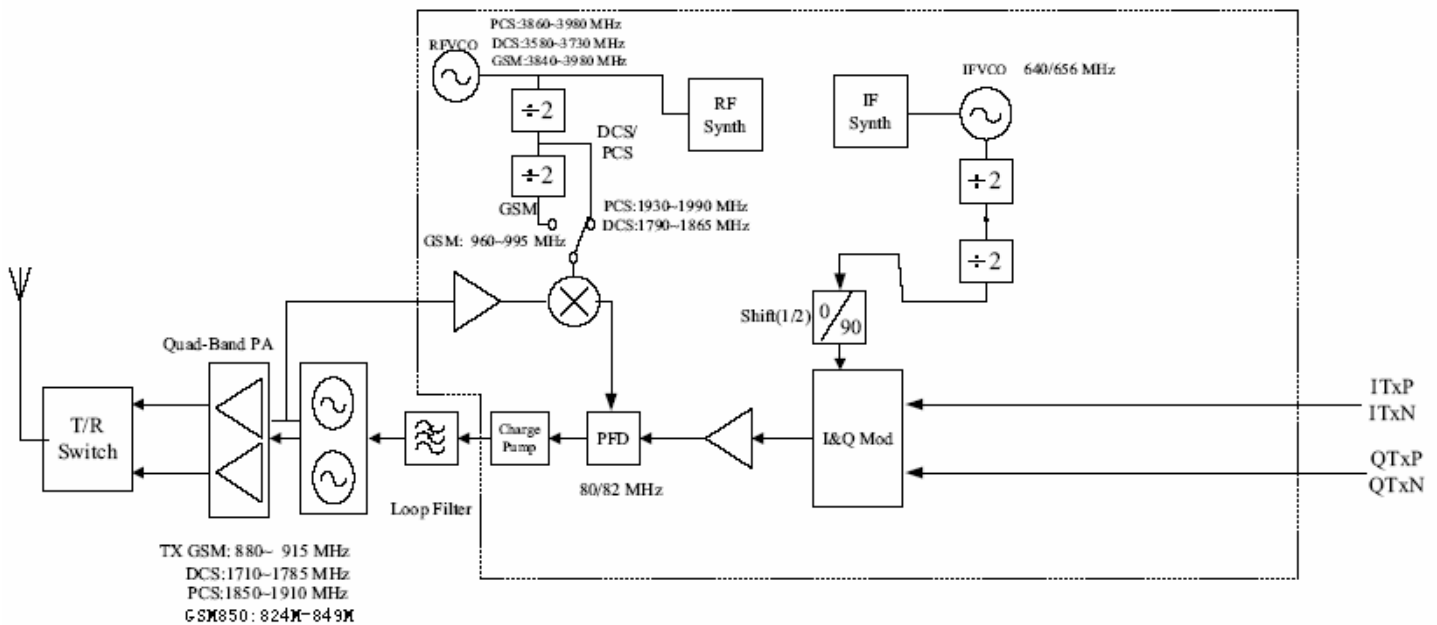

The frequency ranges of the synthesizer for TX mode are

TX mode	GSM850	1813M -1868M
	PCS	2035M-2149M

The transmitter chain converts differential IQ baseband signals to a suitable format for transmission by a power amplifier.

The common mode voltage range of the modulator inputs is 1.0V-1.4V and they have 0.5 Vp-p swing. The modulator circuit uses double-balance mixers for the I/Q paths. The Local signals are generated by dividing the IFLO signals by 8 in GSM band and by 4 in DCS band, and then passed to the modulator through a phase splitter/shifter. The IF signals generated are then summed to produce a signal modulated IF signal which is amplified and fed into the offset PLL block.

Within the offset PLL block there are a down converter, a phase comparator and a VCO driver. The down converter mixes the first local signal and the TXVCO signal to create a reference local signal for use in the offset PLL circuit. The phase comparator and the VCO driver generate an error current, which is proportion to the phase differential between the difference IF and the modulated IF signals, this current is used in a third order loop filter to generate a voltage, which in turn modulates the TXVCO.

The RF signal is then amplified by PA and power control loop to the assigned power level within the burst ramping mask. After passing the LPF of the T/R switch, the signal is then radiated through the antenna.

VCXO Operation

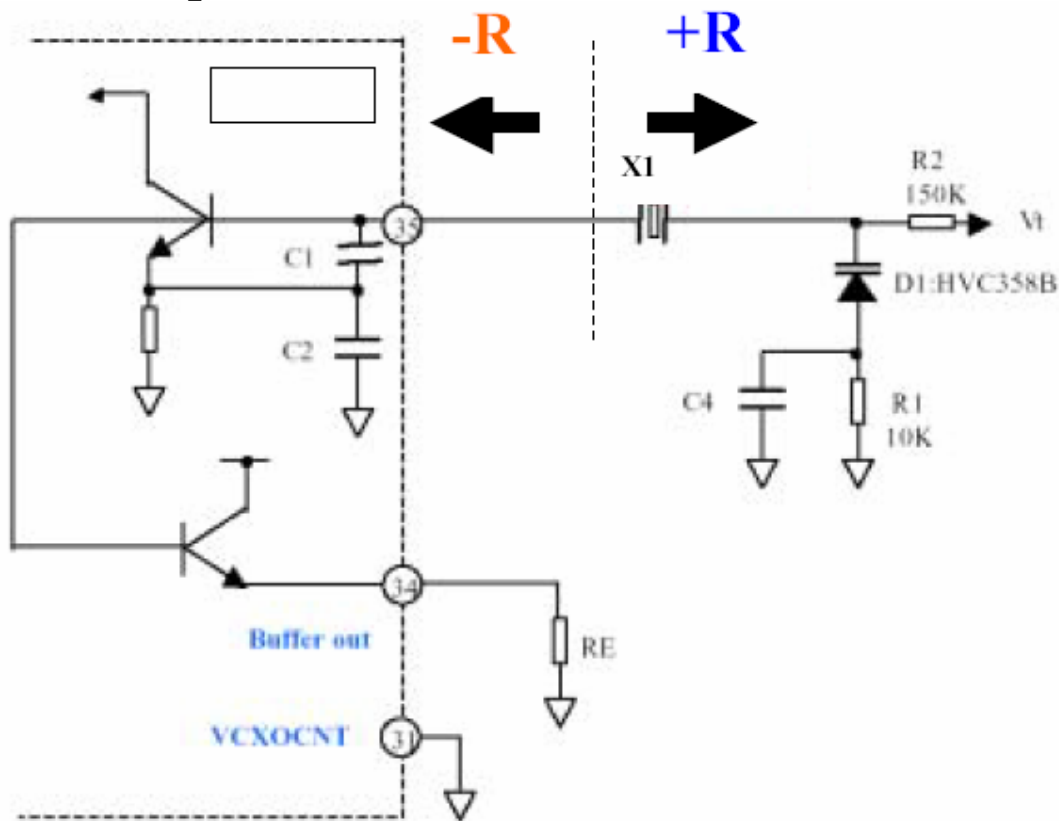

MT6139 provides a VCXO function. With that function, we can build a reference clock generation circuits as shown in the above graph. This means that the VCTCXO module is not necessary for clock application. And only one crystal with 8ppm tolerance and one varactor are enough.

The transistor in MT6139 and two internal capacitors (C1,C2) provide a negative resistance, and the crystal(X1) combined with some other passive components (including varactor:DI) to provide a positive resistance. When these two resistance values equal to each other at some frequency, the oscillation will happen at that frequency. In our design target, the oscillation frequency should be within 26MHz +/-15ppm.

三、RF Specification Requirement

1、TX Average carrier power

POWER LEVEL(GSM850)	max	Range	
	dBm	normal	ultimate
5	33	+/-2 dB*)	+/-2.5 dB*)
6	31	+/-3 dB	+/-3 dB
7	29	+/-3 dB)	+/-4 dB*)
8	27	+/-3 dB	+/-4 dB
9	25	+/-3 dB	+/-4 dB
10	23	+/-3 dB	+/-4 dB
11	21	+/-3 dB	+/-4 dB
12	19	+/-3 dB	+/-4 dB
13	17	+/-3 dB	+/-4 dB
14	15	+/-3 dB	+/-4 dB
15	13	+/-3 dB	+/-4 dB
16	11	+/-5 dB	+/-6 dB
17	9	+/-5 dB	+/-6 dB
18	7	+/-5 dB	+/-6 dB
19	5	+/-5 dB	+/-6 dB

POWER LEVEL(DCS 1800)	max	Range	
	dBm	normal	ultimate
0	30	+/-2 dB*)	+/-2.5dB*)
1	28	+/-3 dB	+/-4 dB
2	26	+/-3 dB	+/-4 dB
3	24	+/-3 dB*)	+/-4 dB*)
4	22	+/-3 dB	+/-4 dB
5	20	+/-3 dB	+/-4 dB
6	18	+/-3 dB	+/-4 dB
7	16	+/-3 dB	+/-4 dB
8	14	+/-3 dB	+/-4 dB
9	12	+/-4 dB	+/-5 dB
10	10	+/-4 dB	+/-5 dB
11	8	+/-4 dB	+/-5 dB
12	6	+/-4 dB	+/-5 dB
13	4	+/-4 dB	+/-5 dB
14	2	+/-5 dB	+/-6 dB
15	0	+/-5 dB	+/-6 dB

- 2、 Frequency Error: 0.1ppm
- 3、 Phase Error
 - (a): Peak Phase Error :20 degree
 - (b): RMS Phase Error :5 degree
- 4、 ORFS(Ouptut Radio Frequency Spectrum) :
 - 400KHz:-60dB
 - 600KHz~1.8MHz:-60dB
- 5、 Switching Spectrum
 - 400KHz:-19dBm@GSM PCL5
 - 400KHz:-22dBm@DCS PCL0
- 6、 Rx Sensitivity
 - 102dBm@RBERRI=2.4%