

# FCC REPORT

**Applicant:** Verykool USA Inc  
**Address of Applicant:** 3636 Nobel Drive, Suite 325, San Diego, CA 92122 USA

**Equipment Under Test (EUT)**

Product Name: Mobile Phone

Model No.: i607

**FCC ID:** WA6I607

**Applicable standards:** FCC CFR Title 47 Part 2: 2011  
FCC CFR Title 47 Part22 Subpart H: 2011  
FCC CFR Title 47 Part24 Subpart E: 2011

**Date of sample receipt:** 08 Jan.,2013

**Date of Test:** 09 Jan., to 21 Jan.2013

**Date of report issued:** 22 Jan.2013

**Test Result :** PASS \*

\* In the configuration tested, the EUT complied with the standards specified above.

Authorized Signature:



Bruce Zhang  
Laboratory Manage

This report details the results of the testing carried out on one sample. The results contained in this test report do not relate to other samples of the same product and does not permit the use of the CCIS product certification mark. The manufacturer should ensure that all products in series production are in conformity with the product sample detailed in this report.

This report may only be reproduced and distributed in full. If the product in this report is used in any configuration other than that detailed in the report, the manufacturer must ensure the new system complies with all relevant standards.

This document cannot be reproduced except in full, without prior written approval of the Company. Any unauthorized alteration, forgery or falsification of the content or appearance of this document is unlawful and offenders may be prosecuted to the fullest extent of the law. Unless otherwise stated the results shown in this test report refer only to the sample(s) tested and such sample(s) are retained for 90 days only.

## 2. Version

Version No.	Date	Description
00	22 Jan.2013	Original

Prepared by:

*Lisa chen*

**Report Clerk**

Date:

22 Jan.2013

Reviewed by:

*Vincent chen*

**Project Engineer**

Date:

22 Jan.2013

## 3. Contents

	Page
<b>1. COVER PAGE</b> .....	<b>1</b>
<b>2. VERSION</b> .....	<b>2</b>
<b>3. CONTENTS</b> .....	<b>3</b>
<b>4. TEST SUMMARY</b> .....	<b>4</b>
<b>5. GENERAL INFORMATION</b> .....	<b>5</b>
5.1 CLIENT INFORMATION.....	5
5.2 GENERAL DESCRIPTION OF E.U.T.....	5
5.3 TEST MODE:.....	7
5.4 RELATED SUBMITTAL(S) / GRANT (S).....	7
5.5 TEST METHODOLOGY.....	7
5.6 TEST FACILITY.....	7
5.7 TEST LOCATION.....	7
5.8 TEST INSTRUMENTS LIST.....	8
<b>6. SYSTEM TEST CONFIGURATION</b> .....	<b>9</b>
6.1 EUT CONFIGURATION.....	9
6.2 EUT EXERCISE.....	9
6.3 CONFIGURATION OF TESTED SYSTEM.....	9
6.4 DESCRIPTION OF TEST MODES.....	9
6.5 CONDUCTED OUTPUT POWER.....	10
6.6 OCCUPY BANDWIDTH.....	12
6.7 MODULATION CHARACTERISTIC.....	18
6.8 OUT OF BAND EMISSION AT ANTENNA TERMINALS.....	18
6.9 ERP, EIRP MEASUREMENT.....	24
6.10 FIELD STRENGTH OF SPURIOUS RADIATION MEASUREMENT.....	27
6.11 FREQUENCY STABILITY V.S. TEMPERATURE MEASUREMENT.....	32
6.12 FREQUENCY STABILITY V.S. VOLTAGE MEASUREMENT.....	39
<b>7 TEST SETUP PHOTO</b> .....	<b>43</b>
<b>8 EUT CONSTRUCTIONAL DETAILS</b> .....	<b>44</b>

## 4. Test Summary

Test Item	Section in CFR 47	Result
RF Exposure (SAR)	Part 1.1307 Part 2.1093	Passed* (Please refer to SAR Report)
RF Output Power	Part 2.1046 Part 22.913 (a)(2) Part 24.232 (c)	Pass
Modulation Characteristics	Part 2.1047	Pass
99% & -26 dB Occupied Bandwidth	Part 2.1049 Part 22.917 Part 24.238	Pass
Spurious Emissions at Antenna Terminal	Part 2.1051 Part 22.917 (a) Part 24.238 (a)	Pass
Field Strength of Spurious Radiation	Part 2.1053 Part 22.917 (a) Part 24.238 (a)	Pass
Out of band emission, Band Edge	Part 22.917 (a) Part 24.238 (a)	Pass
Frequency stability vs. temperature	Part 2.1055(a)(1)(b)	Pass
Frequency stability vs. voltage	Part 2.1055(d)(1)(2)	Pass

*Pass: The EUT complies with the essential requirements in the standard.*

## 5. General Information

### 5.1 Client Information

Applicant:	Verykool USA Inc
Address of Applicant:	4350 Executive Dr. #100, San Diego
Manufacturer:	Verykool Wireless Technology Ltd.
Address of Manufacturer:	Room 1701, Reward Building C, No.203, 2nd Section of WangJing, Li Ze Zhong Yuan, ChaoYang District, Beijing, P.R. of China 100102

### 5.2 General Description of E.U.T.

Product Name:	Mobile Phone
Model No.:	i607
Operation Frequency range:	GSM 850: 824.20MHz-848.80MHz PCS1900: 1850.20MHz-1909.80MHz
IMEI:	IMEI:358003036386524
Software Version:	K603_V1.0.5_2013-1-16
Hardware Version:	I607_VK_MOVISTAR_HW_1.1
Modulation type:	GSM/GPRS:GMSK
Antenna type:	Internal Antenna
Antenna gain:	GSM850: -0.5 dBi PCS1900: -0.8 dBi GSM900: -0.3 dBi DCS1800: -0.7 dBi
AC adapter:	Model:CYSK05-050050 Input:100-240V AC,50/60Hz 0.15A Output:5V DC MAX500mA
Power supply:	Rechargeable Li-ion Battery DC3.7V/700mAh

**Operation Frequency List:**

GSM 850		PCS1900	
Channel:	Frequency (MHz)	Channel:	Frequency (MHz)
128	824.20	512	1850.20
129	824.40	513	1850.40
....	....	....	....
189	836.40	660	1879.80
190	836.60	661	1880.00
191	836.80	662	1880.20
...	...	...	...
250	848.60	809	1909.60
251	848.80	810	1909.80

Regards to the operating frequency range over 10 MHz, the Lowest frequency, the middle frequency, and the highest frequency of channel were selected to perform the test, and the selected channel see below:

GSM850			PCS1900		
	Channel	Frequency(MHz)		Channel	Frequency(MHz)
Lowest channel	128	824.20	Lowest channel	512	1850.20
Middle channel	190	836.60	Middle channel	661	1880.00
Highest channel	251	848.80	Highest channel	810	1909.80

### 5.3 Test mode:

Communicate mode (GSM850)	Keep the EUT in communicating mode on GSM850 band.
Data mode (GPRS850)	Keep the EUT in data communicating mode on GPRS850 band.
Communicate mode (PCS1900)	Keep the EUT in communicating mode on PCS1900 band.
Data mode (GPRS1900)	Keep the EUT in data communicating mode on GPRS1900 band.

### 5.4 Related Submittal(s) / Grant (s)

This submittal(s) (test report) is filing to comply with Section Part 22 subpart H and Part 24 subpart E of the FCC CFR 47 Rules.

### 5.5 Test Methodology

Both conducted and radiated testing were performed according to the procedures document on TIA/EIA 603 and FCC CFR 47.1046, 2.1047, 2.1049, 2.1051, 2.1053, 2.1055 and 2.1057

### 5.6 Test Facility

The test facility is recognized, certified, or accredited by the following organizations:

● **FCC —Registration No.:** 817957

China Certification & Inspection Services Co., Ltd., Shenzhen EMC Laboratory has been registered and fully described in a report filed with the (FCC) Federal Communications Commission. The acceptance letter from the FCC is maintained in our files. Registration 817957, February 27, 2012

● **Industry Canada (IC)**

The 3m Semi-anechoic chamber of China Certification & Inspection Services Co., Ltd. Has been Registered by Certification and Engineering Bureau of Industry Canada for radio equipment testing with Registration No.: 10106A-1.

### 5.7 Test Location

All tests were performed at:

China Certification & Inspection Services Co., Ltd.  
 Address: 1st Floor, Block No.2, Laodong Industrial Zone, Xixiang Road Baoan District, Shenzhen, China  
 Tel: 0755-23118282  
 Fax: 0755-23116366

## 5.8 Test Instruments list

Radiated Emission:						
Item	Test Equipment	Manufacturer	Model No.	Inventory No.	Cal.Date (dd-mm-yy)	Cal.Due date (dd-mm-yy)
1	3m Semi- Anechoic Chamber	SAEMC	9(L)*6(W)* 6(H)	CCIS0001	June 09 2012	June 08 2013
2	BiConiLog Antenna	SCHWARZBECK MESS-ELEKTRONIK	VULB9163	CCIS0005	June 04 2012	June 03 2013
3	Double -ridged waveguide horn	SCHWARZBECK MESS-ELEKTRONIK	BBHA9120D	CCIS0006	May 30 2012	May 29 2013
4	EMI Test Software	AUDIX	E3	N/A	N/A	N/A
5	Coaxial Cable	CCIS	N/A	CCIS0016	Apr. 01 2012	Mar. 31 2013
6	Coaxial Cable	CCIS	N/A	CCIS0017	Apr. 01 2012	Mar. 31 2013
7	Coaxial cable	CCIS	N/A	CCIS0018	Apr. 01 2012	Mar. 31 2013
8	Coaxial Cable	CCIS	N/A	CCIS0019	Apr. 01 2012	Mar. 31 2013
9	Coaxial Cable	CCIS	N/A	CCIS0087	Apr. 01 2012	Mar. 31 2013
10	Amplifier(10kHz-1.3GHz)	HP	8447D	CCIS0003	Apr. 01 2012	Mar. 31 2013
11	Amplifier(1GHz-18GHz)	Compliance Direction Systems Inc.	PAP-1G18	CCIS0011	June 09 2012	June 08 2013
12	Pre-amplifier (18-26GHz)	Rohde & Schwarz	AFS33-18002 650-30-8P-44	GTS218	Apr. 01 2012	Mar. 31 2013
13	Horn Antenna	ETS-LINDGREN	3160	GTS217	Mar. 30 2012	Mar. 29 2013
14	Printer	HP	HP LaserJet P1007	N/A	N/A	N/A
15	Positioning Controller	UC	UC3000	CCIS0015	N/A	N/A
16	Spectrum analyzer 9k-30GHz	Rohde & Schwarz	FSP	CCIS0023	May. 29 2012	May. 28 2013
17	EMI Test Receiver	Rohde & Schwarz	ESPI	CCIS0022	Apr 01 2012	Mar. 31 2013
18	Loop antenna	Laplace instrument	RF300	EMC0701	Aug. 12 2012	Aug. 11 2013
19	Universal radio communication tester	Rhode & Schwarz	CMU200	CCIS0069	May. 29 2012	May. 28 2013



## 6. System test configuration

### 6.1 EUT Configuration

The EUT configuration for testing is installed on RF field strength measurement to meet the commission's requirement and operating in a manner which intends to maximize its emission characteristics in a continuous normal application.

### 6.2 EUT Exercise

The EUT (Transmitter) was operated in the engineering mode to fix the Tx frequency which was for the purpose of the measurements.

### 6.3 Configuration of Tested System

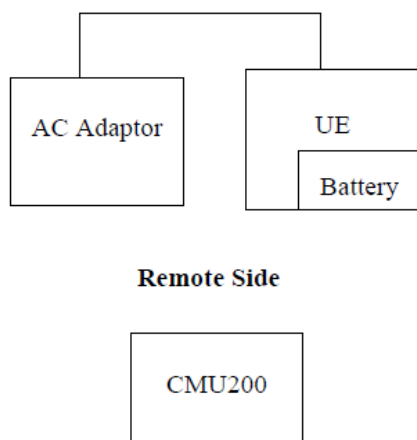

### 6.4 DESCRIPTION OF TEST MODES

The EUT has been tested under operating condition. EUT staying in continuous transmitting mode. Channel Low, Mid and High for each type band with rated data rate were chosen for full testing. The field strength of spurious radiation emission was measured as EUT stand-up position (H mode) and lie down position (E1, E2 mode) for three modes (GSM850, PCS1900, WCDMA Band V and WCDMA Band II) with power adaptor, earphone and Data cable. The worst-case H mode for GSM850, PCS1900, UMTS 850 and UMTS 1900.

## 6.5 Conducted Output Power

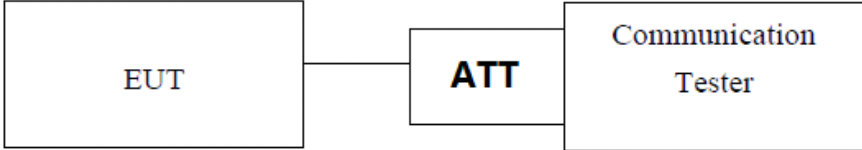
Test Requirement:	FCC part22.913(a) and FCC part24.232(b)
Test Method:	FCC part2.1046
Limit:	GSM850 7W PCS1900 2W
Test setup:	 <p style="text-align: center;"><i>Note: Measurement setup for testing on Antenna connector</i></p>
Test Procedure:	The transmitter output was connected to a calibrated attenuator, the other end of which was connected to the CMU200. Transmitter output was read off the CMU200 in dBm.
Test Instruments:	Refer to section 5.8 for details
Test mode:	Refer to section 5.3 for details
Test results:	Passed

Measurement Data

EUT Mode	Channel	Frequency (MHz)	Burst Average power (dBm)	Limit(dBm)	Result
GSM 850	128	824.20	31.70	38.45	Pass
	190	836.60	31.70		
	251	848.80	31.80		
GPRS 850 (1 Uplink slot)	128	824.20	31.68		
	190	836.60	31.70		
	251	848.80	31.75		
GPRS 850 (2 Uplink slots)	128	824.20	31.06		
	190	836.60	31.09		
	251	848.80	31.13		
GPRS 850 (3 Uplink slots)	128	824.20	29.60		
	190	836.60	29.67		
	251	848.80	29.76		
GPRS 850 (4 Uplink slots)	128	824.20	28.69		
	190	836.60	28.76		
	251	848.80	28.88		
PCS 1900	512	1850.20	28.90	33.00	Pass
	661	1880.00	28.80		
	810	1909.80	28.30		
GPRS 1900 (1 Uplink slot)	512	1850.20	28.87		
	661	1880.00	28.71		
	810	1909.80	28.22		
GPRS 1900 (2 Uplink slots)	512	1850.20	27.96		
	661	1880.00	27.85		
	810	1909.80	27.46		
GPRS 1900 (3 Uplink slots)	512	1850.20	27.08		
	661	1880.00	27.00		
	810	1909.80	26.59		
GPRS 1900 (4 Uplink slots)	512	1850.20	26.90		
	661	1880.00	26.81		
	810	1909.80	26.43		

## 6.6 Occupy Bandwidth

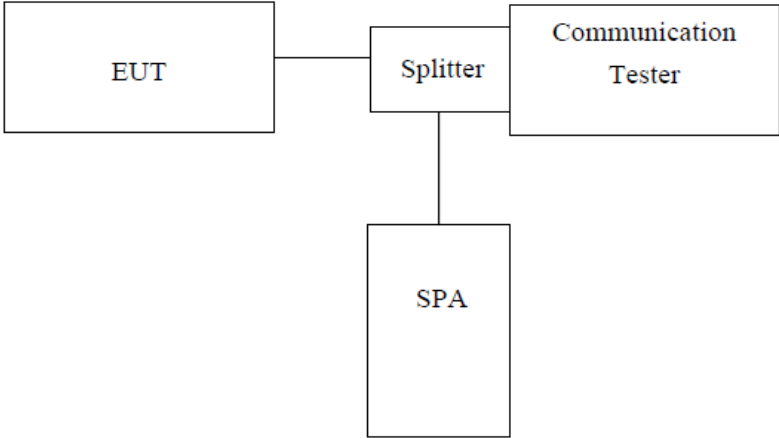
Test Requirement:	FCC part22.913(a) and FCC part24.232(b)
Test Method:	FCC part2.1049
Test setup:	 <p><i>Note: Measurement setup for testing on Antenna connector</i></p>
Test Procedure:	<ol style="list-style-type: none"> <li>1. The EUT's output RF connector was connected with a short cable to the spectrum analyzer</li> <li>2. RBW was set to about 1% of emission BW, VBW= 3 times RBW.</li> <li>3. -26dBc display line was placed on the screen (or 99% bandwidth), the occupied bandwidth is the delta frequency between the two points where the display line intersects the signal trace.</li> </ol>
Test Instruments:	Refer to section 5.8 for details
Test mode:	Refer to section 5.3 for details
Test results:	Passed

### Measurement Data

EUT Mode	Channel	Frequency (MHz)	99% Occupy bandwidth (kHz)	-26dB bandwidth (kHz)
GSM 850	128	824.2	242	314
	190	836.6	240	314
	251	848.8	246	314
PCS 1900	512	1850.2	244	316
	661	1880.0	244	314
	810	1909.8	248	320

Test plot as follows:

Test Item:	99% Occupy bandwidth	Test Mode:	GSM850
------------	----------------------	------------	--------

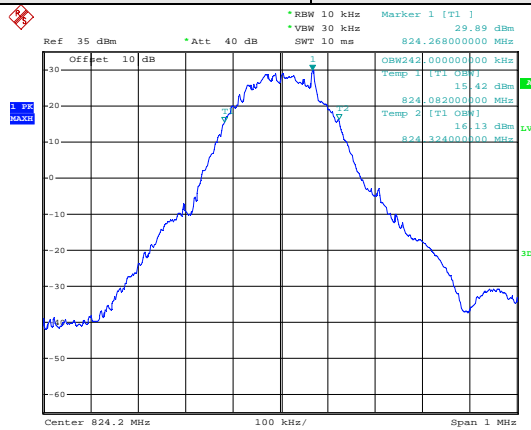

Lowest channel

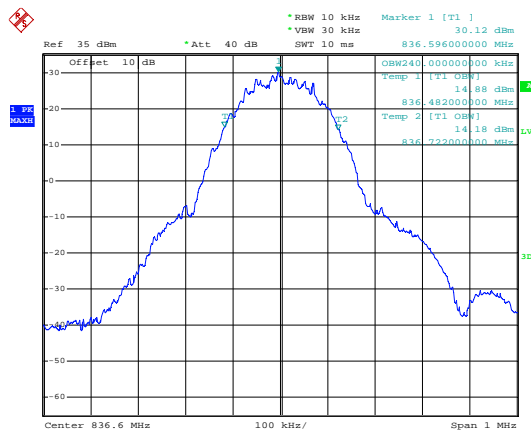

Middle channel

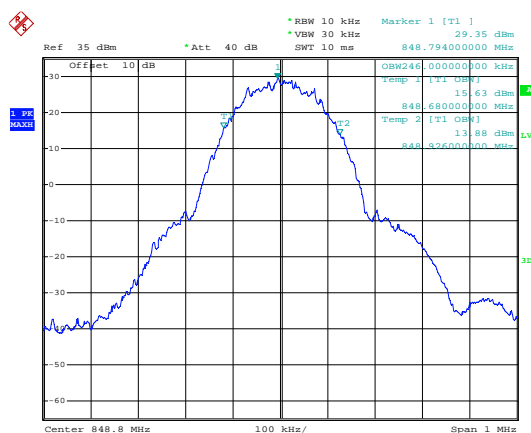

Highest channel

Test Item:	-26dB bandwidth	Test Mode:	GSM850
------------	-----------------	------------	--------

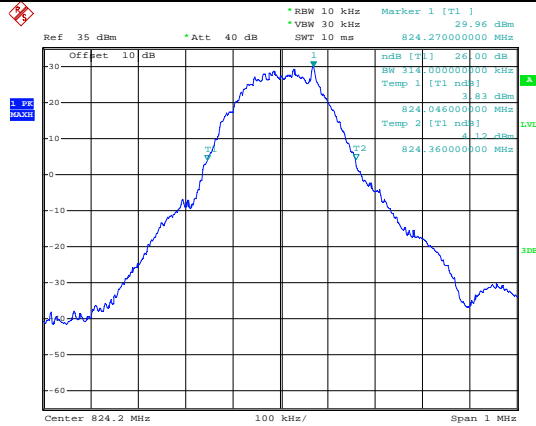

Lowest channel

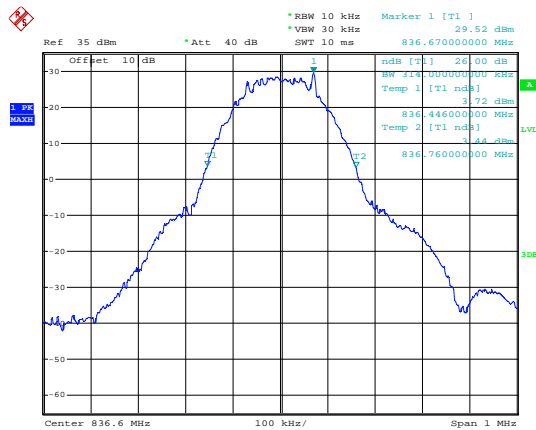

Middle channel

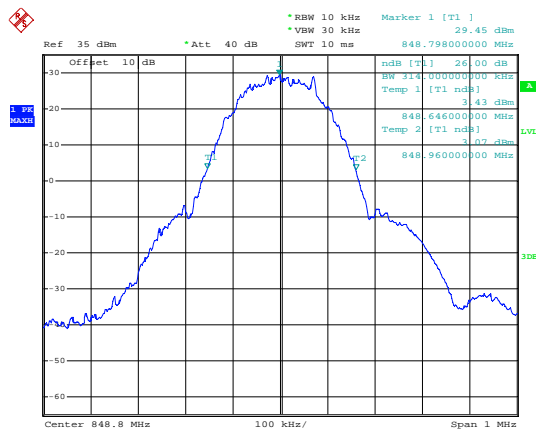

Highest channel

Test Item:	99% Occupancy bandwidth	Test Mode:	PCS 1900
------------	-------------------------	------------	----------

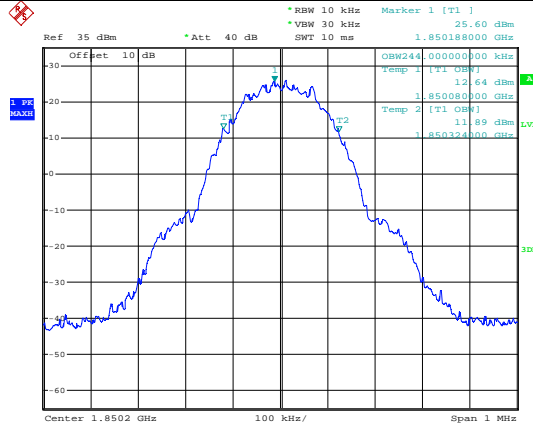

Lowest channel

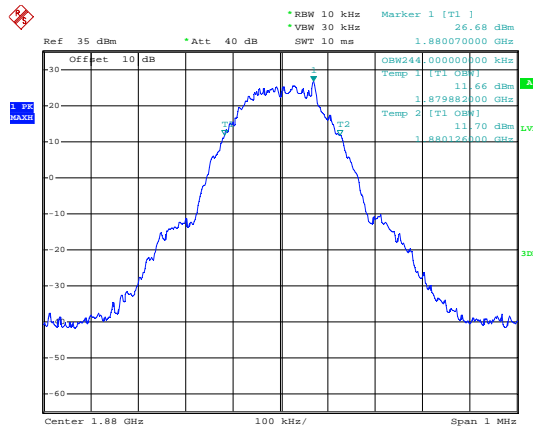

Middle channel

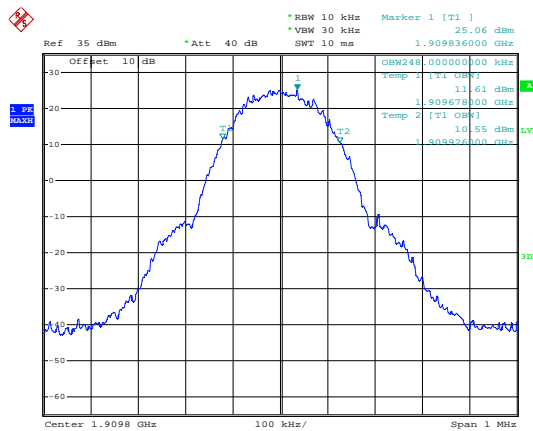

Highest channel



Test Item:	-26dB bandwidth	Test Mode:	PCS 1900
------------	-----------------	------------	----------

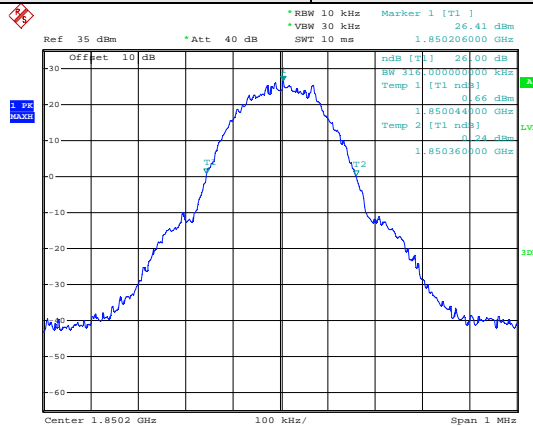

Lowest channel

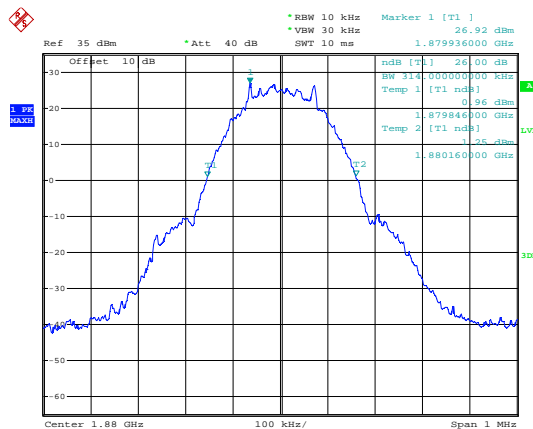

Middle channel

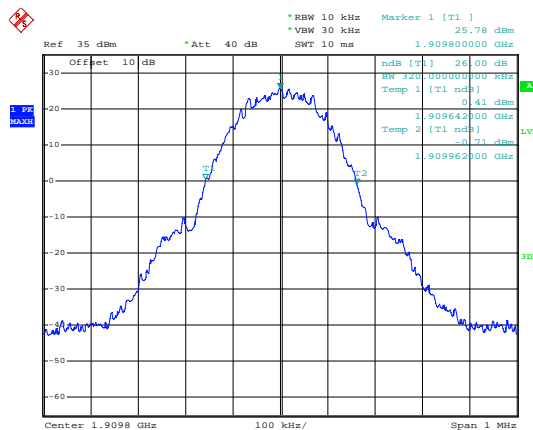

Highest channel

## 6.7 MODULATION CHARACTERISTIC

According to FCC § 2.1047(d), Part 22H & 24E there is no specific requirement for digital modulation, therefore modulation characteristic is not presented.

## 6.8 Out of band emission at antenna terminals

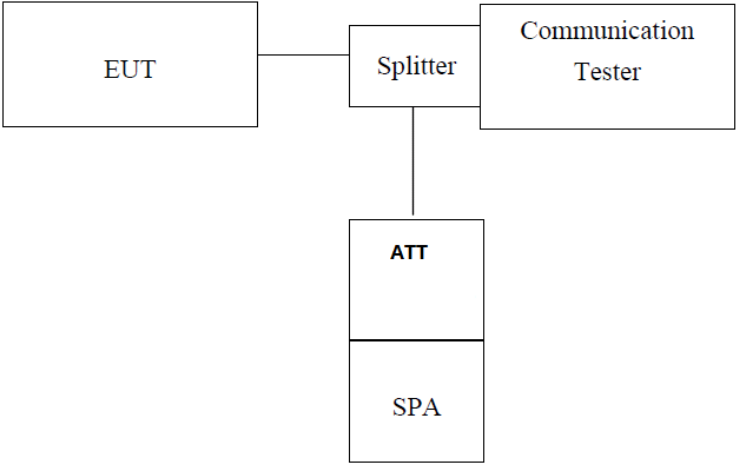
Test Requirement:	FCC part22.917(a) and FCC part24.238(a)
Test Method:	FCC part2.1051
Limit:	-13dBm
Test setup:	 <p><i>Note: Measurement setup for testing on Antenna connector</i></p>
Test Procedure:	<ol style="list-style-type: none"> <li>1 The RF output of the transceiver was connected to a spectrum analyzer through appropriate attenuation.</li> <li>2 The resolution bandwidth of the spectrum analyzer was set at 100 kHz when below 1GHz, 1MHz when above 1 GHz; sufficient scans were taken to show the out of band Emissions if any up to 10th harmonic.</li> <li>3 For the out of band: Set the RBW=100 kHz, VBW=300 kHz when below 1 GHz, RBW =1 MHz, VBW=3 MHz when above 1 GHz, Start=30MHz, Stop= 10th harmonic.</li> <li>4 Band Edge Requirements: In the 1 MHz bands immediately outside and adjacent to the frequency block, a resolution bandwidth of at least 1 percent of the emission bandwidth of the fundamental emission of the transmitter may be employed to measure the out of band Emissions.</li> </ol>
Test Instruments:	Refer to section 5.8 for details
Test mode:	Refer to section 5.3 for details
Test results:	Passed

Test plot as follows:

## Spurious emission

Test Mode:	GSM850	Test Channel:	Lowest channel
------------	--------	---------------	----------------

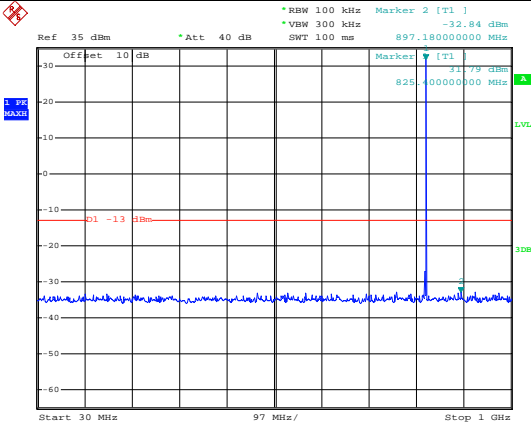

Date: 22.JAN.2013 03:31:35

30MHz~1GHz

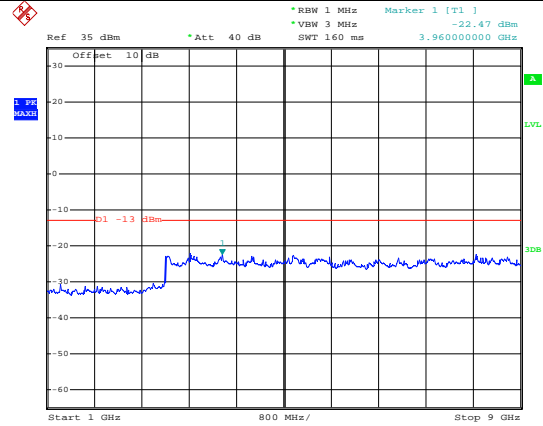

Date: 15.JAN.2013 03:11:07

1GHz~9GHz

Test Mode:	GSM850	Test Channel:	Middle channel
------------	--------	---------------	----------------

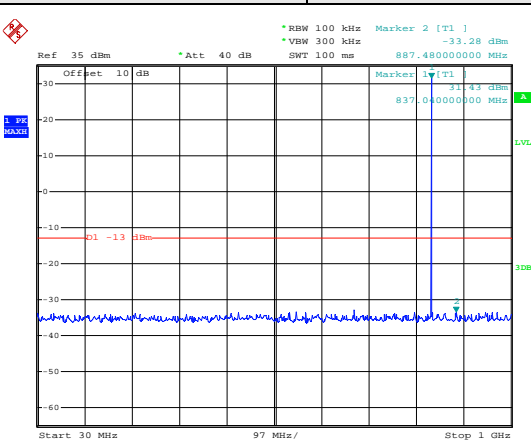

Date: 22.JAN.2013 03:32:11

30MHz~1GHz

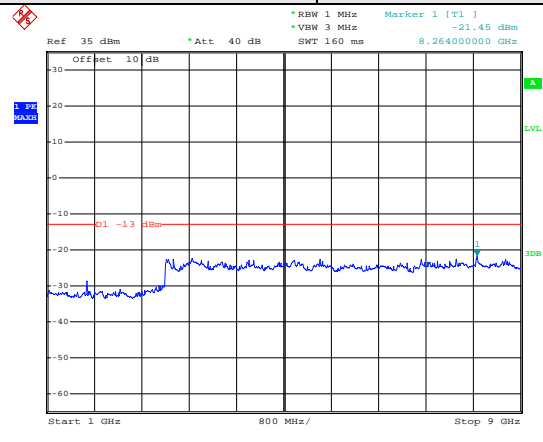

Date: 15.JAN.2013 03:11:55

1GHz~9GHz

Test Mode:	GSM850	Test Channel:	Highest channel
------------	--------	---------------	-----------------

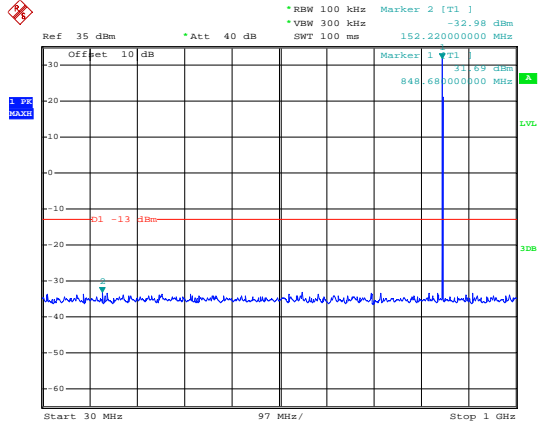

Date: 22.JAN.2013 03:32:49

30MHz~1GHz

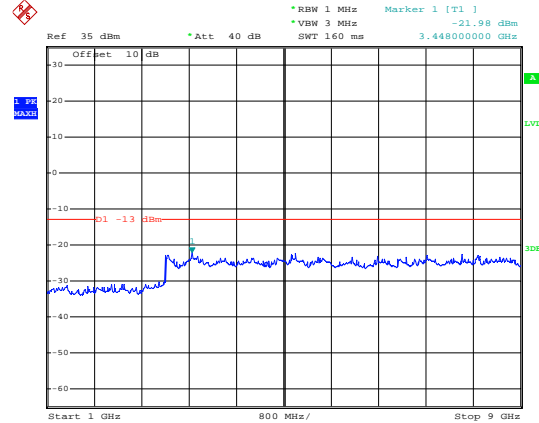

Date: 15.JAN.2013 03:13:57

1GHz~9GHz

Test Mode:	PCS1900	Test Channel:	Lowest channel
------------	---------	---------------	----------------

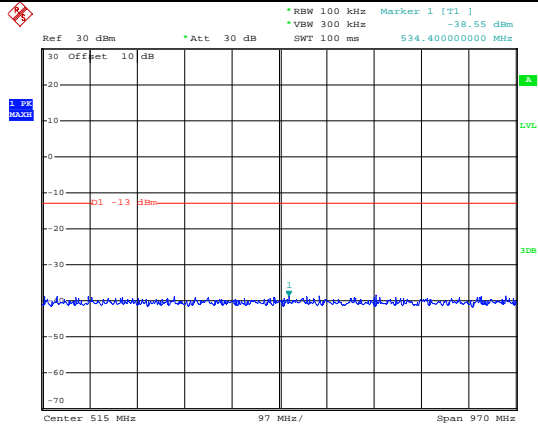

Date: 15.JAN.2013 03:33:36

30MHz~1GHz

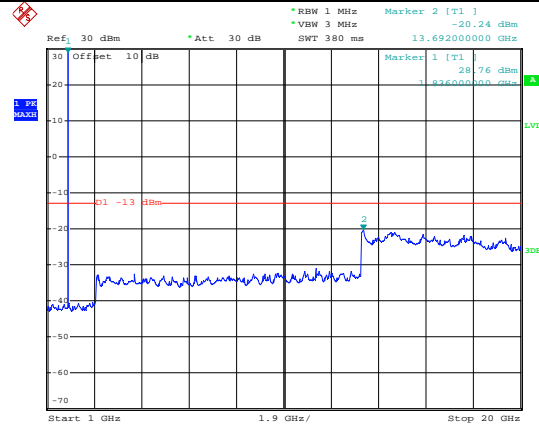

Date: 22.JAN.2013 03:49:46

1GHz~20GHz

Test Mode:	PCS1900	Test Channel:	Middle channel
------------	---------	---------------	----------------

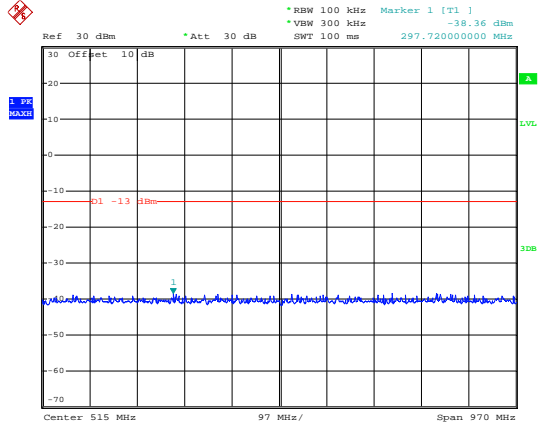

Date: 15.JAN.2013 03:34:11

30MHz~1GHz

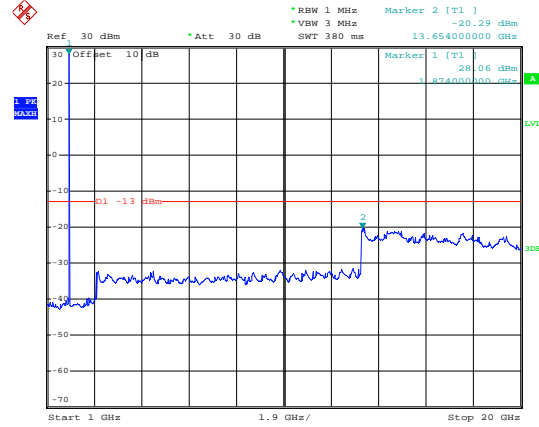

Date: 22.JAN.2013 03:50:43

1GHz~20GHz

Test Mode:	PCS1900	Test Channel:	Highest channel
------------	---------	---------------	-----------------

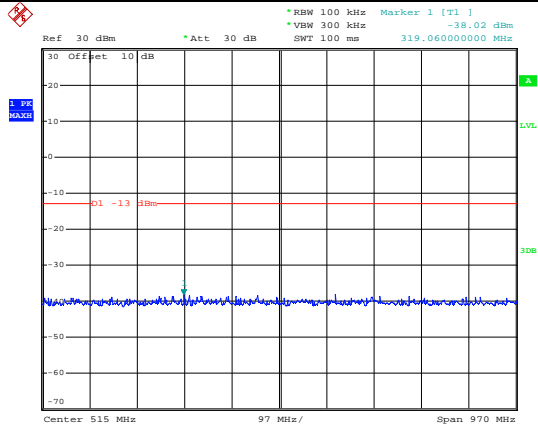

Date: 15.JAN.2013 03:34:49

30MHz~1GHz

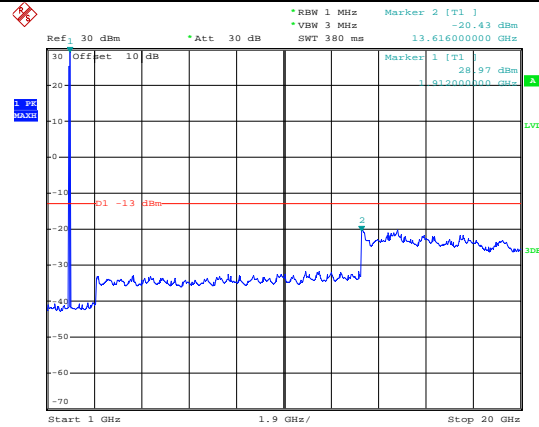

Date: 22.JAN.2013 03:51:50

1GHz~20GHz

**Band edge emission:**

Test Mode:	GSM850
------------	--------

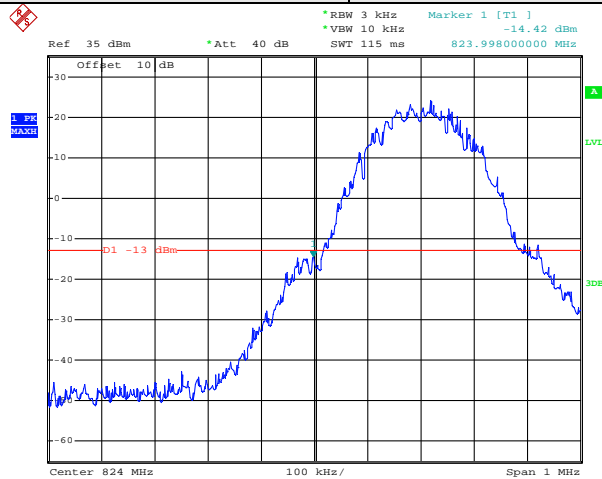

Date: 15.JAN.2013 03:01:11

**Lowest channel**

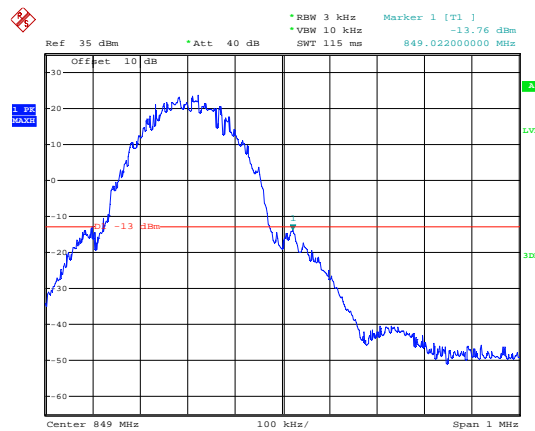

Date: 15.JAN.2013 03:06:49

**Highest channel**

Test Mode:	PCS1900
------------	---------

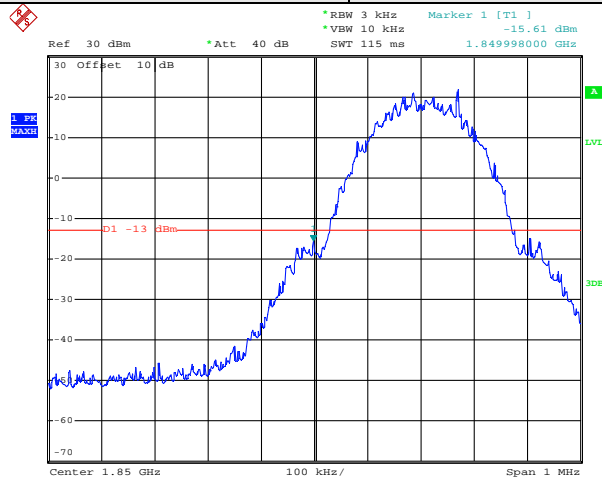

Date: 15.JAN.2013 03:25:47

### Lowest channel

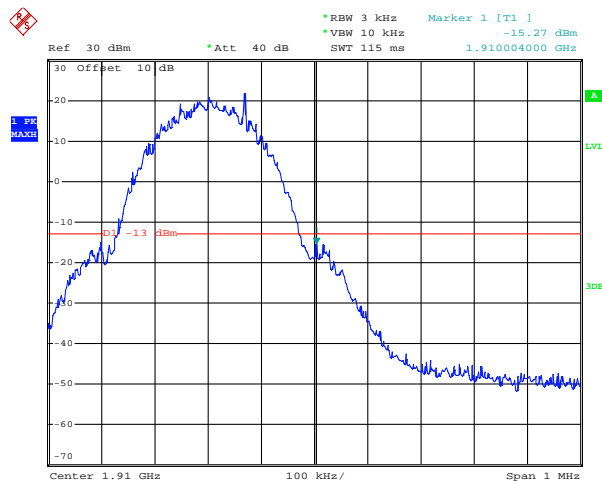

Date: 15.JAN.2013 03:26:53

### Highest channel

## 6.9 ERP, EIRP Measurement

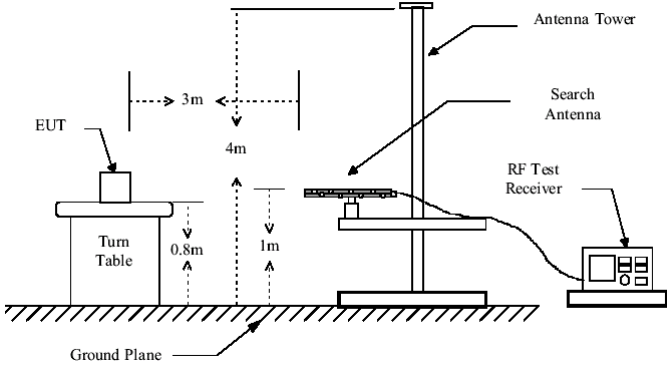
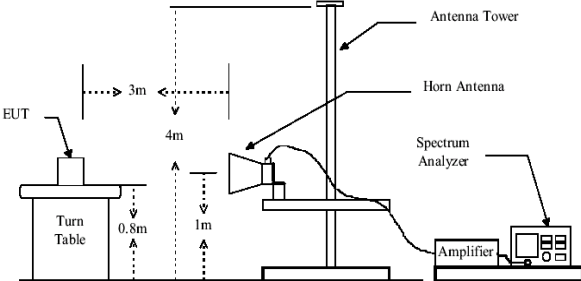
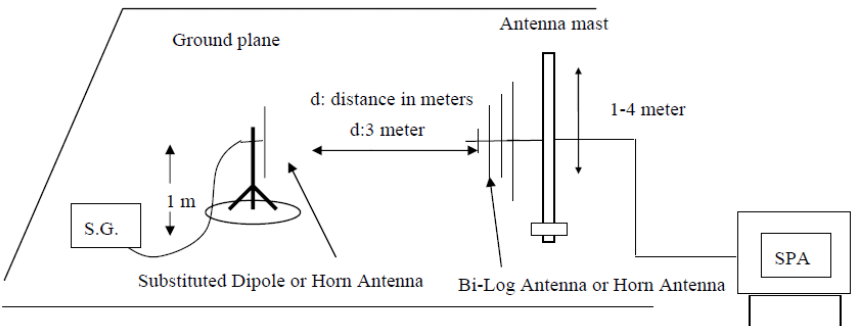
Test Requirement:	FCC part22.913(a) and FCC part24.232(b)
Test Method:	FCC part2.1046
Limit:	GSM850 7W ERP PCS1900 2W EIRP
Test setup:	<p>Below 1GHz</p>  <p>Above 1GHz</p>  <p>Substituted method:</p> 



<p>Test Procedure:</p>	<ol style="list-style-type: none"> <li>1. The EUT was placed on an non-conductive turntable using a non-conductive support. The radiated emission at the fundamental frequency was measured at 3 m with a test antenna and EMI spectrum analyzer.</li> <li>2. During the measurement, the EUT was communication with the station. The highest emission was recorded with the rotation of the turntable and the lowering of the test antenna from 4m to 1m. The reading was recorded and the field strength (E in dBuV/m) was calculated.</li> <li>3. ERP in frequency band 824.2 –848.80.8MHz were measured using a substitution method. The EUT was replaced by dipole antenna connected, the S.G. output was recorded and ERP was calculated as follows:  <math display="block">\text{ERP} = \text{S.G. output (dBm)} + \text{Antenna Gain (dBd)} - \text{Cable Loss (dB)}</math> </li> <li>4. EIRP in frequency band 1850.2 –1909.8MHz were measured using a substitution method. The EUT was replaced by or horn antenna connected, the S.G. output was recorded and EIRP was calculated as follows:  <math display="block">\text{EIRP} = \text{S.G. output (dBm)} + \text{Antenna Gain (dBi)} - \text{Cable Loss (dB)}</math> </li> <li>5. The worse case was relating to the conducted output power.</li> </ol>
<p>Test Instruments:</p>	<p>Refer to section 5.8 for details</p>
<p>Test mode:</p>	<p>Refer to section 5.3 for details</p>
<p>Test results:</p>	<p>Passed</p>

## Measurement Data

EUT mode	Channel	EUT Pol.	Antenna Pol.	ERP(dBm)	Limit (dBm)	Result
GSM850	190	H	V	32.33	38.45	Pass
			H	26.55		
		E1	V	28.67		
			H	25.31		
		E2	V	28.67		
			H	25.55		
GPRS850	190	H	V	32.20		
			H	26.43		

EUT mode	Channel	EUT Pol.	Antenna Pol.	EIRP(dBm)	Limit (dBm)	Result
PCS1900	512	H	V	26.35	33.00	Pass
			H	23.86		
		E1	V	25.84		
			H	23.10		
		E2	V	25.11		
			H	22.75		
GPRS1900	512	H	V	26.24		
			H	23.69		

## 6.10 Field strength of spurious radiation measurement

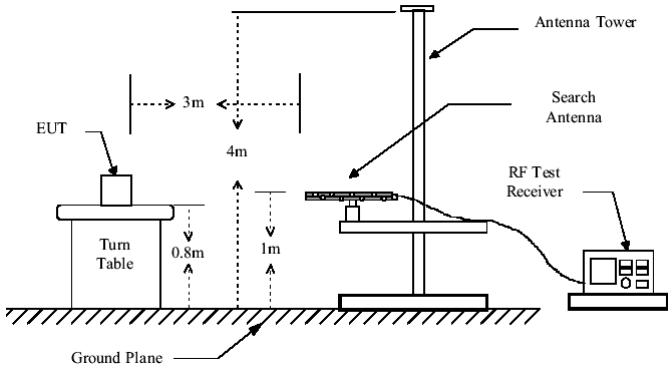
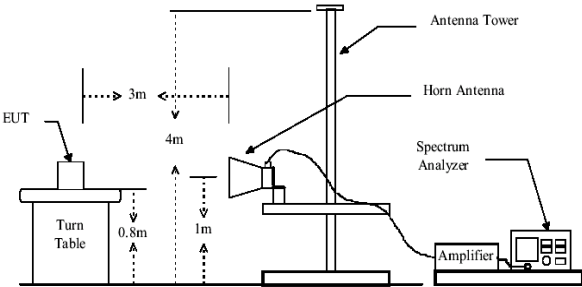
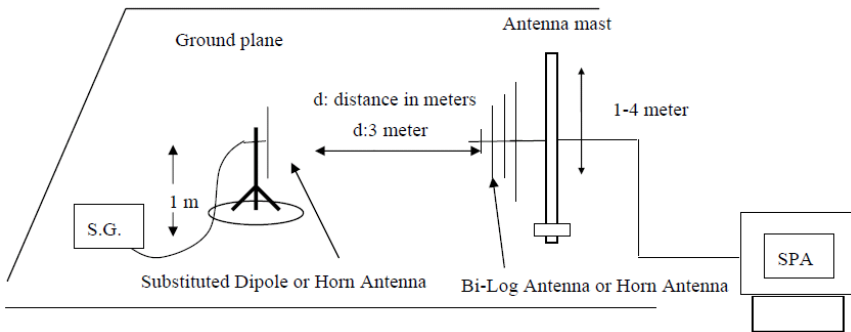
Test Requirement:	FCC part22.917(a) and FCC part24.238(a)
Test Method:	FCC part2.1053
Limit:	-13dBm
Test setup:	<p>Below 1GHz</p>  <p>Above 1GHz</p>  <p>Substituted method:</p> 
Test Procedure:	<ol style="list-style-type: none"> <li>1. The EUT was placed on an non-conductive turntable using a non-conductive support. The radiated emission at the fundamental frequency was measured at 3 m with a test antenna and EMI spectrum analyzer.</li> <li>2. During the tests, the antenna height and the EUT azimuth were varied in order to identify the maximum level of emissions from the EUT. This maximization process was repeated with the EUT</li> </ol>

	<p>positioned in each of its three orthogonal orientations.</p> <p>3. The frequency range up to tenth harmonic was investigated for each of three fundamental frequency (low, middle and high channels). Once spurious emission was identified, the power of the emission was determined using the substitution method.</p> <p>4. The spurious emissions attenuation was calculated as the difference between radiated power at the fundamental frequency and the spurious emissions frequency.  <math display="block">\text{ERP / EIRP} = \text{S.G. output (dBm)} + \text{Antenna Gain(dB/dBi)} - \text{Cable Loss (dB)}</math></p>
Test Instruments:	Refer to section 5.8 for details
Test mode:	Refer to section 5.3 for details
Test results:	Passed

Measurement Data (worse case)

Test mode:	GSM850		Test channel:	Lowest
Frequency (MHz)	Spurious Emission		Limit (dBm)	Result
	Polarization	ERP Level (dBm)		
1648.40	Vertical	-31.46	-13.00	Pass
2472.60	V	-40.09		
3296.80	V	-39.69		
4121.00	V	-40.94		
4945.20	V	---		
5769.40	V	---		
1648.40	Horizontal	-33.3	-13.00	Pass
2472.60	H	-35.19		
3296.80	H	-40.95		
4121.00	H	-37.01		
4945.20	H	---		
5769.40	H	---		
Test mode:	GSM850		Test channel:	Middle
Frequency (MHz)	Spurious Emission		Limit (dBm)	Result
	Polarization	ERP Level (dBm)		
1673.20	Vertical	-33.76	-13.00	Pass
2509.80	V	-34.13		
3346.40	V	-45.05		
4183.00	V	-34.87		
5019.60	V	---		
5856.20	V	---		
1673.20	Horizontal	-46.06	-13.00	Pass
2509.80	H	-34.95		
3346.40	H	-40.96		
4183.00	H	-38.58		
5019.60	H	---		
5856.20	H	---		

Remark :

1. The emission behavior belongs to narrowband spurious emission.
2. Remark"---" means that the emission level is too low to be measured
3. The emission levels of below 1 GHz are very lower than the limit and not show in test report.

Test mode:	GSM850		Test channel:	Highest
Frequency (MHz)	Spurious Emission		Limit (dBm)	Result
	Polarization	ERP Level (dBm)		
1697.60	Vertical	-38.73	-13.00	Pass
2546.40	V	-36.91		
3395.20	V	-45.14		
4244.00	V	-43.61		
5092.80	V	---		
5941.60	V	---		
1697.60	Horizontal	-43.96	-13.00	Pass
2546.40	H	-35.9		
3395.20	H	-45.17		
4244.00	H	-35.55		
5092.80	H	---		
5941.60	H	---		
Test mode:	PCS1900		Test channel:	Lowest
Frequency (MHz)	Spurious Emission		Limit (dBm)	Result
	Polarization	EIRP Level (dBm)		
3700.40	Vertical	-45.06	-13.00	Pass
5550.60	V	-40.31		
7400.80	V	-40.21		
9251.00	V	-38.95		
11101.20	V	---		
12951.40	V	---		
3700.40	Horizontal	-48.97	-13.00	Pass
5550.60	H	-43.89		
7400.80	H	-41.65		
9251.00	H	-40.02		
11101.20	H	---		
12951.40	H	---		

Remark :

1. The emission behavior belongs to narrowband spurious emission.
2. Remark"---" means that the emission level is too low to be measured
3. The emission levels of below 1 GHz are very lower than the limit and not show in test report.

Test mode:	PCS1900		Test channel:	Middle
Frequency (MHz)	Spurious Emission		Limit (dBm)	Result
	Polarization	EIRP Level (dBm)		
3760.00	Vertical	-47.17	-13.00	Pass
5640.00	V	-44.23		
7520.00	V	-40.8		
9400.00	V	-38.91		
11280.00	V	---		
13160.00	V	---		
3760.00	Horizontal	-49.37	-13.00	Pass
5640.00	H	-44.06		
7520.00	H	-42.83		
9400.00	H	-40.26		
11280.00	H	---		
13160.00	H	---		
Test mode:	PCS1900		Test channel:	Highest
Frequency (MHz)	Spurious Emission		Limit (dBm)	Result
	Polarization	EIRP Level (dBm)		
3819.60	Vertical	-46.68	-13.00	Pass
5729.40	V	-44.96		
7639.20	V	-42.12		
9549.00	V	-39.48		
11458.80	V	---		
13368.60	V	---		
3819.60	Horizontal	-44.23	-13.00	Pass
5729.40	H	-43.8		
7639.20	H	-40.83		
9549.00	H	-39.31		
11458.80	H	---		
13368.60	H	---		

Remark :

1. The emission behavior belongs to narrowband spurious emission.
2. Remark"---" means that the emission level is too low to be measured
3. The emission levels of below 1 GHz are very lower than the limit and not show in test report.

## 6.11 Frequency stability V.S. Temperature measurement

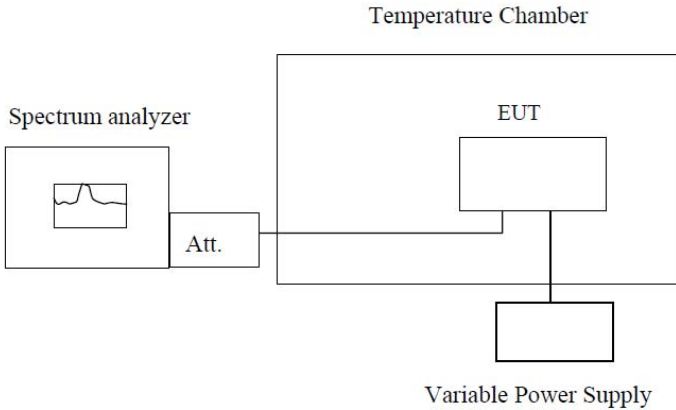
Test Requirement:	FCC Part2.1055(a)(1)(b)
Test Method:	FCC Part2.1055(a)(1)(b)
Limit:	2.5ppm
Test setup:	 <p style="text-align: center;"><b>Note :</b> Measurement setup for testing on Antenna connector</p>
Test procedure:	<ol style="list-style-type: none"> <li>1. The equipment under test was connected to an external DC power supply and input rated voltage.</li> <li>2. RF output was connected to a frequency counter or spectrum analyzer via feed through attenuators.</li> <li>3. The EUT was placed inside the temperature chamber.</li> <li>4. Set the spectrum analyzer RBW low enough to obtain the desired frequency resolution and measure EUT 25°C operating frequency as reference frequency.</li> <li>5. Turn EUT off and set the chamber temperature to -30°C. After the temperature stabilized for approximately 30 minutes recorded the frequency.</li> <li>6. Repeat step measure with 10°C increased per stage until the highest temperature of +50°C reached</li> </ol>
Test Instruments:	Refer to section 5.8 for details
Test mode:	Refer to section 5.3 for details
Test results:	Passed



Measurement Data

Reference Frequency: GSM850 Lowest channel=128 channel=824.2MHz					
Power supplied (Vdc)	Temperature (°C)	Frequency error		Limit (ppm)	Result
		Hz	ppm		
3.70	-30	41	0.049745	2.5	Pass
	-20	33	0.040039		
	-10	42	0.050959		
	0	32	0.038826		
	10	42	0.050959		
	20	36	0.043679		
	30	44	0.053385		
	40	40	0.048532		
	50	43	0.052172		
Reference Frequency: PCS1900 Lowest channel=512 channel=1850.2MHz					
Power supplied (Vdc)	Temperature (°C)	Frequency error		Limit (ppm)	Result
		Hz	ppm		
3.70	-30	33	0.017836	2.5	Pass
	-20	36	0.019457		
	-10	37	0.019998		
	0	36	0.019457		
	10	45	0.024322		
	20	37	0.019998		
	30	42	0.022700		
	40	45	0.024322		
	50	43	0.023241		

Reference Frequency: GPRS850 Lowest channel=128 channel=824.2MHz					
Power supplied (Vdc)	Temperature (°C)	Frequency error		Limit (ppm)	Result
		Hz	ppm		
3.70	-30	39	0.047319	2.5	Pass
	-20	27	0.032759		
	-10	43	0.052172		
	0	34	0.041252		
	10	41	0.049745		
	20	28	0.033972		
	30	42	0.050959		
	40	33	0.040039		
	50	41	0.049745		
Reference Frequency: GPRS1900 Lowest channel=512 channel=1850.2MHz					
Power supplied (Vdc)	Temperature (°C)	Frequency error		Limit (ppm)	Result
		Hz	ppm		
3.70	-30	25	0.013512	2.5	Pass
	-20	37	0.019998		
	-10	34	0.018376		
	0	34	0.018376		
	10	45	0.024322		
	20	31	0.016755		
	30	30	0.016214		
	40	43	0.023241		
	50	34	0.018376		

Reference Frequency: GSM850 Middle channel=190 channel=836.6MHz					
Power supplied (Vdc)	Temperature (°C)	Frequency error		Limit (ppm)	Result
		Hz	ppm		
3.70	-30	44	0.052594	2.5	Pass
	-20	38	0.045422		
	-10	39	0.046617		
	0	46	0.054984		
	10	45	0.053789		
	20	42	0.050203		
	30	49	0.058570		
	40	43	0.051399		
	50	46	0.054984		
Reference Frequency: PCS1900 Middle channel=661 channel=1880MHz					
Power supplied (Vdc)	Temperature (°C)	Frequency error		Limit (ppm)	Result
		Hz	ppm		
3.70	-30	47	0.025000	2.5	Pass
	-20	36	0.019149		
	-10	46	0.024468		
	0	34	0.018085		
	10	37	0.019681		
	20	39	0.020745		
	30	35	0.018617		
	40	45	0.023936		
	50	44	0.023404		

Reference Frequency: GPRS850 Middle channel=190 channel=836.6MHz					
Power supplied (Vdc)	Temperature (°C)	Frequency error		Limit (ppm)	Result
		Hz	ppm		
3.70	-30	22	0.026297	2.5	Pass
	-20	34	0.040641		
	-10	27	0.032273		
	0	36	0.043031		
	10	40	0.047813		
	20	44	0.052594		
	30	44	0.052594		
	40	36	0.043031		
	50	43	0.051399		
Reference Frequency: GPRS1900 Middle channel=661 channel=1880MHz					
Power supplied (Vdc)	Temperature (°C)	Frequency error		Limit (ppm)	Result
		Hz	ppm		
3.70	-30	42	0.022340	2.5	Pass
	-20	33	0.017553		
	-10	43	0.022872		
	0	22	0.011702		
	10	33	0.017553		
	20	35	0.018617		
	30	26	0.013830		
	40	34	0.018085		
	50	44	0.023404		

Reference Frequency: GSM850 Highest channel=251 channel=848.8 MHz					
Power supplied (Vdc)	Temperature (°C)	Frequency error		Limit (ppm)	Result
		Hz	ppm		
3.70	-30	42	0.049482	2.5	Pass
	-20	37	0.043591		
	-10	34	0.040057		
	0	47	0.055372		
	10	46	0.054194		
	20	47	0.055372		
	30	39	0.045947		
	40	38	0.044769		
	50	43	0.050660		
Reference Frequency: PCS1900 Highest channel=810 channel=1909.8MHz					
Power supplied (Vdc)	Temperature (°C)	Frequency error		Limit (ppm)	Result
		Hz	ppm		
3.70	-30	37	0.019374	2.5	Pass
	-20	33	0.017279		
	-10	45	0.023563		
	0	47	0.024610		
	10	42	0.021992		
	20	45	0.023563		
	30	31	0.016232		
	40	33	0.017279		
	50	38	0.019897		

Reference Frequency: GPRS850 Highest channel=251 channel=848.8 MHz					
Power supplied (Vdc)	Temperature (°C)	Frequency error		Limit (ppm)	Result
		Hz	ppm		
3.70	-30	34	0.040057	2.5	Pass
	-20	34	0.040057		
	-10	32	0.037700		
	0	43	0.050660		
	10	39	0.045947		
	20	35	0.041235		
	30	32	0.037700		
	40	36	0.042413		
	50	30	0.035344		
Reference Frequency: GPRS1900 Highest channel=810 channel=1909.8MHz					
Power supplied (Vdc)	Temperature (°C)	Frequency error		Limit (ppm)	Result
		Hz	ppm		
3.70	-30	32	0.016756	2.5	Pass
	-20	31	0.016232		
	-10	44	0.023039		
	0	44	0.023039		
	10	32	0.016756		
	20	39	0.020421		
	30	32	0.016756		
	40	25	0.013090		
	50	32	0.016756		

## 6.12 Frequency stability V.S. Voltage measurement

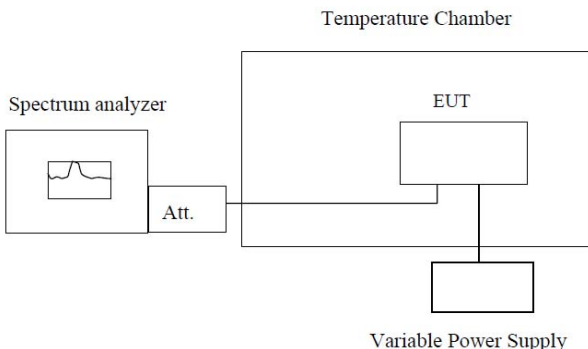
Test Requirement:	FCC Part2.1055(d)(1)(2)
Test Method:	FCC Part2.1055(d)(1)(2)
Limit:	2.5ppm
Test setup:	 <p><b>Note :</b> Measurement setup for testing on Antenna connector</p>
Test procedure:	<ol style="list-style-type: none"> <li>1. Set chamber temperature to 25°C. Use a variable DC power source to power the EUT and set the voltage to rated voltage.</li> <li>2. Set the spectrum analyzer RBW low enough to obtain the desired frequency resolution and recorded the frequency.</li> <li>3. Reduce the input voltage to specified extreme voltage variation (+/- 15%) and endpoint, record the maximum frequency change.</li> </ol>
Test Instruments:	Refer to section 5.8 for details
Test mode:	Refer to section 5.3 for details
Test results:	Passed

### Measurement Data

Reference Frequency: GSM850 Lowest channel=128 channel=824.2MHz					
Temperature (°C)	Power supplied (Vdc)	Frequency error		Limit (ppm)	Result
		Hz	ppm		
25	4.25	37	0.044892	2.5	Pass
	3.70	35	0.042465		
	3.40	37	0.044892		
Reference Frequency: PCS1900 Lowest channel=512 channel=1850.2MHz					
Temperature (°C)	Power supplied (Vdc)	Frequency error		Limit (ppm)	Result
		Hz	ppm		
25	4.25	42	0.022700	2.5	Pass
	3.70	39	0.021079		
	3.40	37	0.019998		
Reference Frequency: GPRS850 Lowest channel=128 channel=824.2MHz					
Temperature (°C)	Power supplied (Vdc)	Frequency error		Limit (ppm)	Result
		Hz	ppm		
25	4.25	41	0.049745	2.5	Pass
	3.70	33	0.040039		
	3.40	46	0.055812		
Reference Frequency: GPRS1900 Lowest channel=512 channel=1850.2MHz					
Temperature (°C)	Power supplied (Vdc)	Frequency error		Limit (ppm)	Result
		Hz	ppm		
25	4.25	52	0.028105	2.5	Pass
	3.70	45	0.024322		
	3.40	42	0.022700		



Reference Frequency: GSM850 Middle channel=190 channel=836.6MHz					
Temperature (°C)	Power supplied (Vdc)	Frequency error		Limit (ppm)	Result
		Hz	ppm		
25	4.25	35	0.041836	2.5	Pass
	3.70	32	0.038250		
	3.40	43	0.051399		
Reference Frequency: PCS1900 Middle channel=661 channel=1880MHz					
Temperature (°C)	Power supplied (Vdc)	Frequency error		Limit (ppm)	Result
		Hz	ppm		
25	4.25	41	0.021809	2.5	Pass
	3.70	46	0.024468		
	3.40	43	0.022872		
Reference Frequency: GPRS850 Middle channel=190 channel=836.6MHz					
Temperature (°C)	Power supplied (Vdc)	Frequency error		Limit (ppm)	Result
		Hz	ppm		
25	4.25	30	0.035859	2.5	Pass
	3.70	33	0.039445		
	3.40	42	0.050203		
Reference Frequency: GPRS1900 Middle channel=661 channel=1880MHz					
Temperature (°C)	Power supplied (Vdc)	Frequency error		Limit (ppm)	Result
		Hz	ppm		
25	4.25	42	0.022340	2.5	Pass
	3.70	38	0.020213		
	3.40	44	0.023404		

Reference Frequency: GSM850 Highest channel=251 channel=848.8MHz					
Temperature (°C)	Power supplied (Vdc)	Frequency error		Limit (ppm)	Result
		Hz	ppm		
25	4.25	38	0.044769	2.5	Pass
	3.70	36	0.042413		
	3.40	37	0.043591		
Reference Frequency: PCS1900 Highest channel=810 channel=1909.8MHz					
Temperature (°C)	Power supplied (Vdc)	Frequency error		Limit (ppm)	Result
		Hz	ppm		
25	4.25	34	0.017803	2.5	Pass
	3.70	36	0.018850		
	3.40	47	0.024610		
Reference Frequency: GPRS850 Highest channel=251 channel=848.8MHz					
Temperature (°C)	Power supplied (Vdc)	Frequency error		Limit (ppm)	Result
		Hz	ppm		
25	4.25	36	0.042413	2.5	Pass
	3.70	29	0.034166		
	3.40	33	0.038878		
Reference Frequency: GPRS1900 Highest channel=810 channel=1909.8MHz					
Temperature (°C)	Power supplied (Vdc)	Frequency error		Limit (ppm)	Result
		Hz	ppm		
25	4.25	32	0.016756	2.5	Pass
	3.70	35	0.018327		
	3.40	38	0.019897		