

REVISION RECORD			
LTR	ECO NO.	APPROVED:	DATE:

JTAG

Serial Flash WSON-8

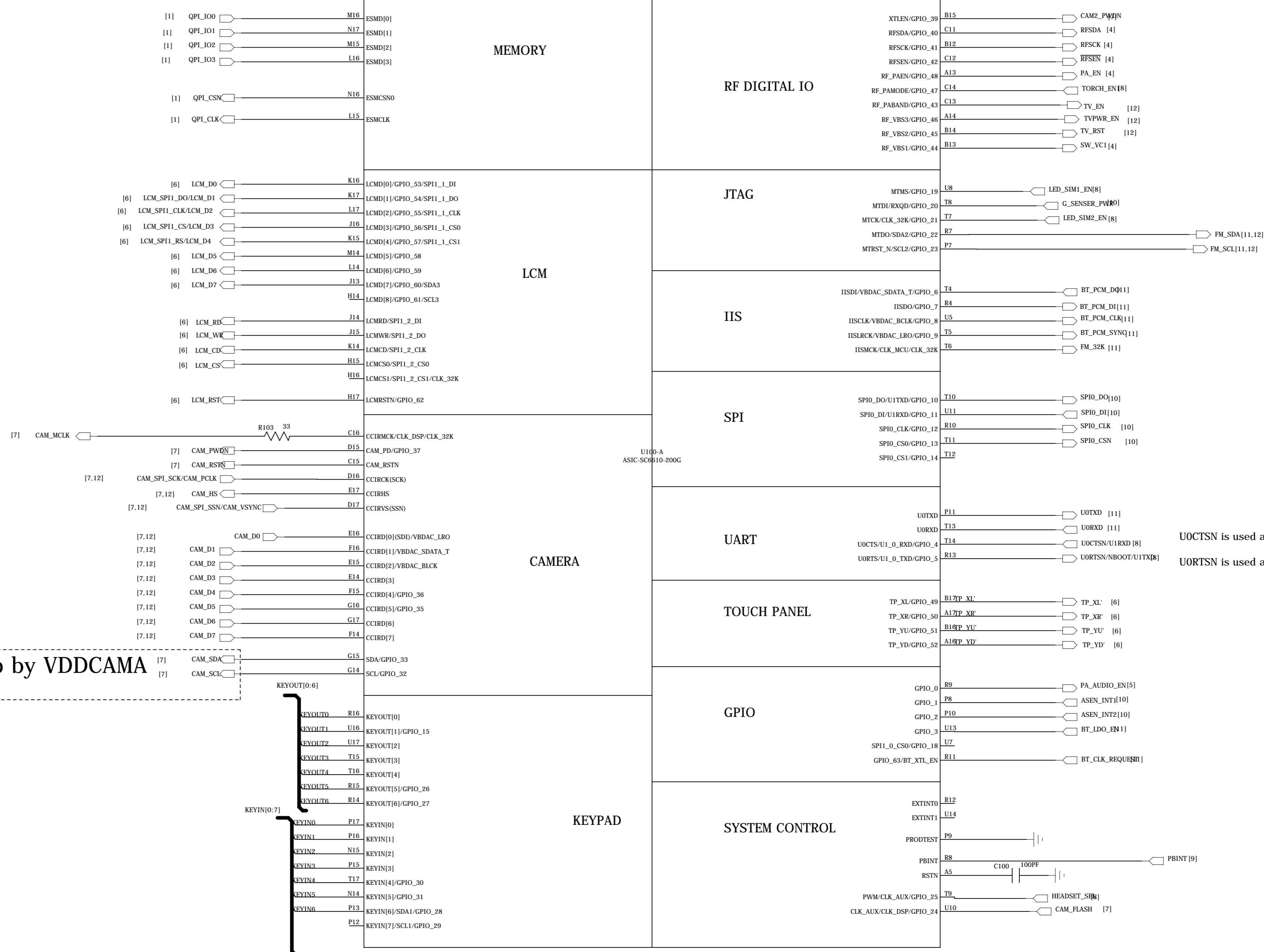
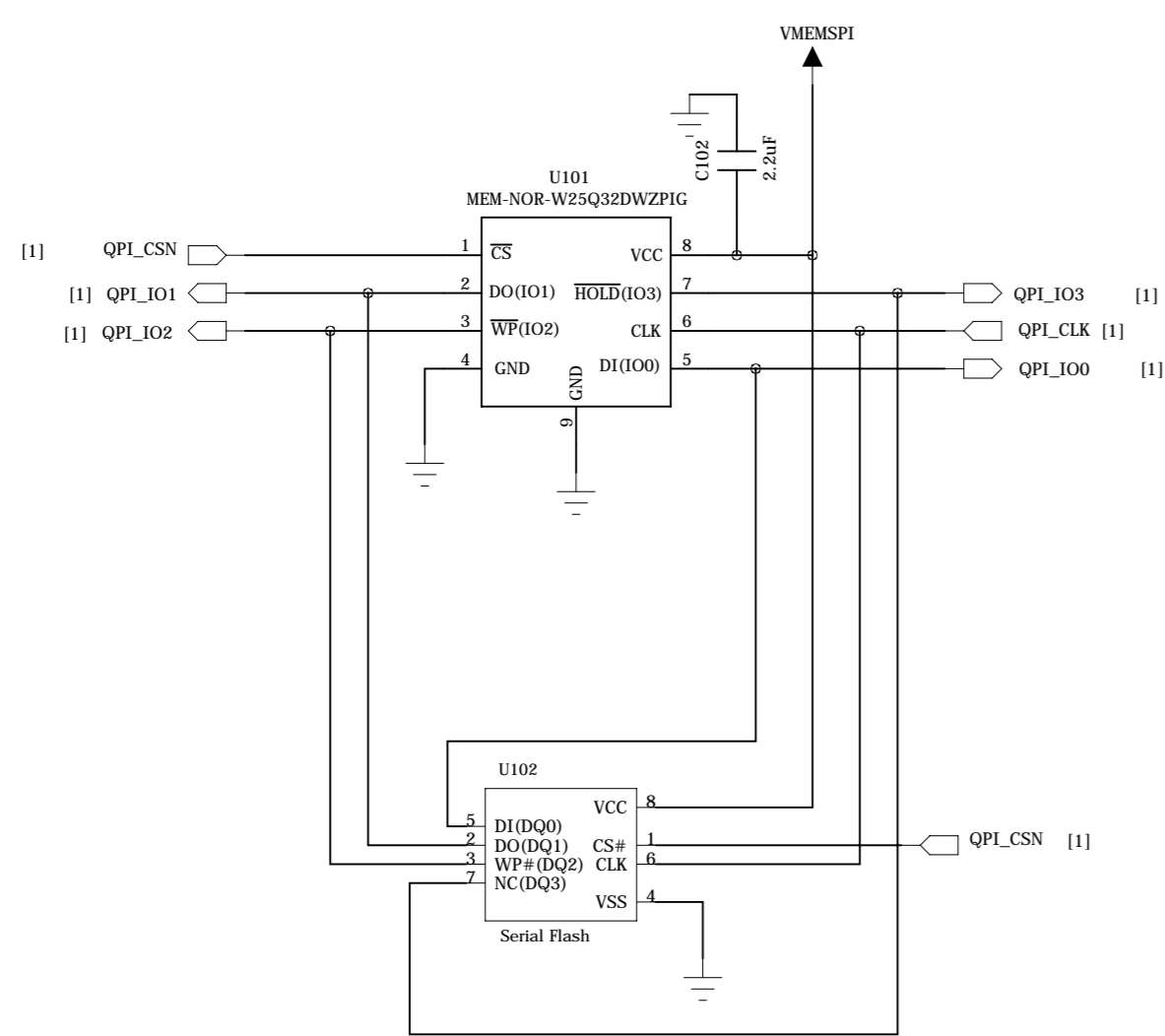

I2C has been pulled up by VDDCAMA
don't pull up it again

TITLE & REV: SC6610_PLATFORM_REFERENCE_SCH_V1.0.0.sch	
DOCUMENT NO.: HW-SC6610-SCH-2011-0001	
DESIGNER: Franks.Miao	DATED: 2011-02-14
EQA: Robin.Zhang	DATED: 2011-02-14
APPROVED: Guobing.Luan	DATED: 2011-02-14

DEPARTMENT: Hardware RD.	COMPANY: Spreadtrum communications, Inc.
CONFIDENTIAL AND PROPRIETARY	

REVISION RECORD			
LTR	ECO NO.	APPROVED:	DATE:

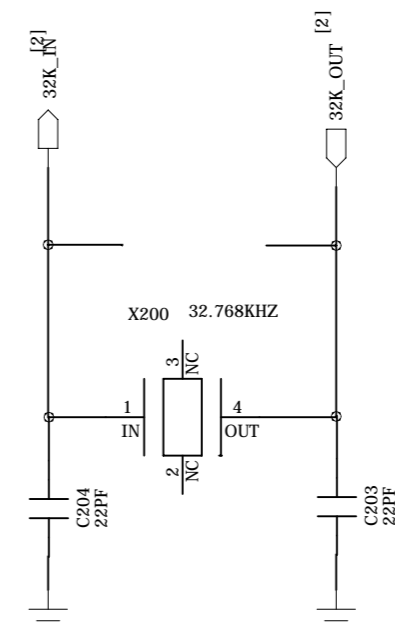
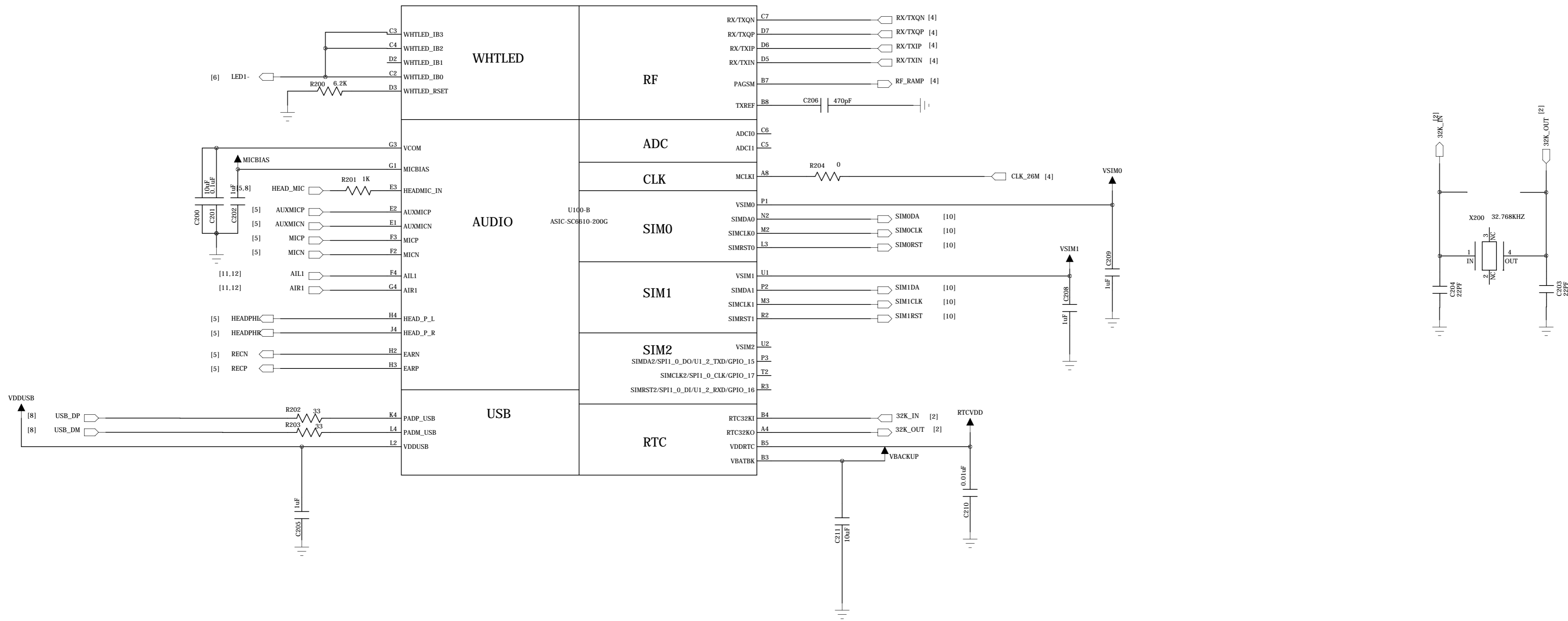

TITLE & REV: SC6610_PLATFORM_REFERENCE_SCH_V1.0.0.sch	
DOCUMENT NO.: HW-SC6610-SCH-2011-0001	
DESIGNER: Franks.Miao	DATED: 2011-02-14
EQA: Robin.Zhang	DATED: 2011-02-14
APPROVED: Guobing.Luan	DATED: 2011-02-14

DEPARTMENT: Hardware RD.
COMPANY: Spreadtrum communications, Inc.

REVISION RECORD			
LTR	ECO NO.	APPROVED:	DATE:

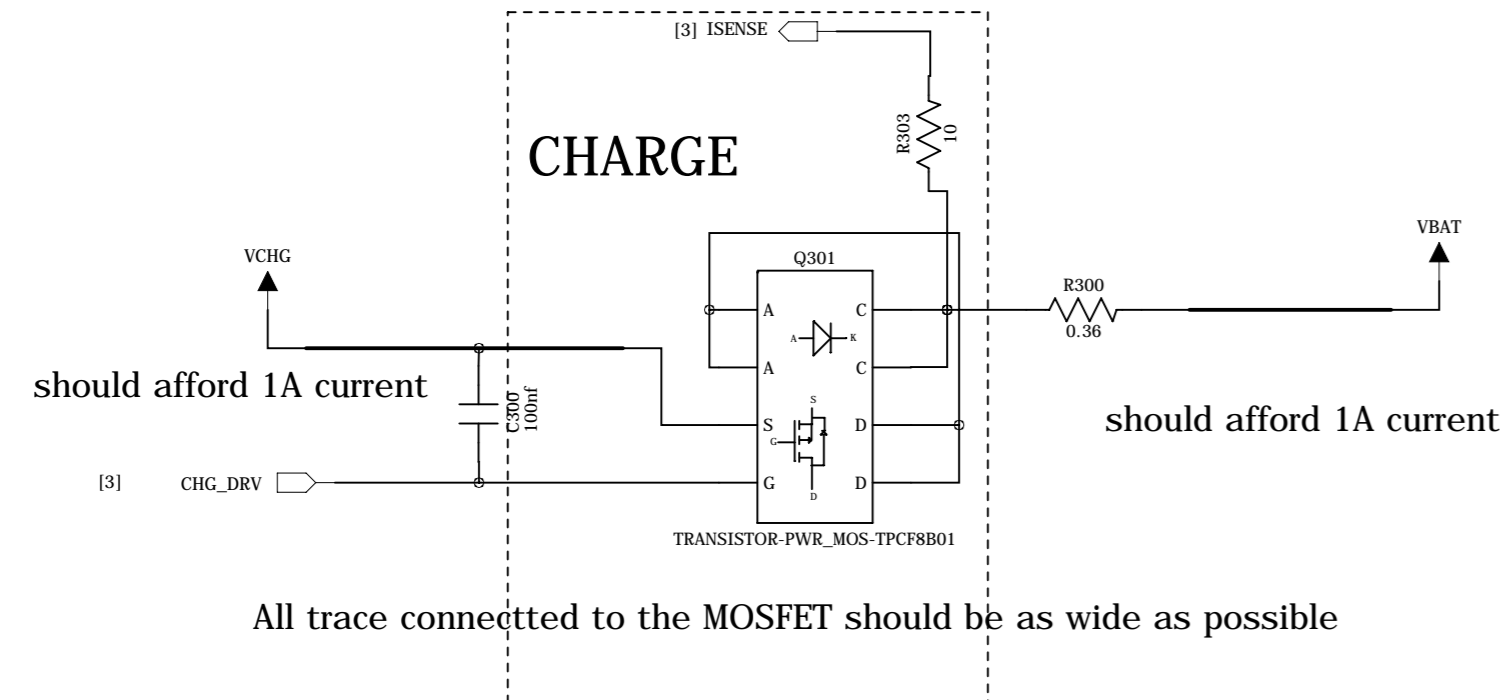

BAT CON.

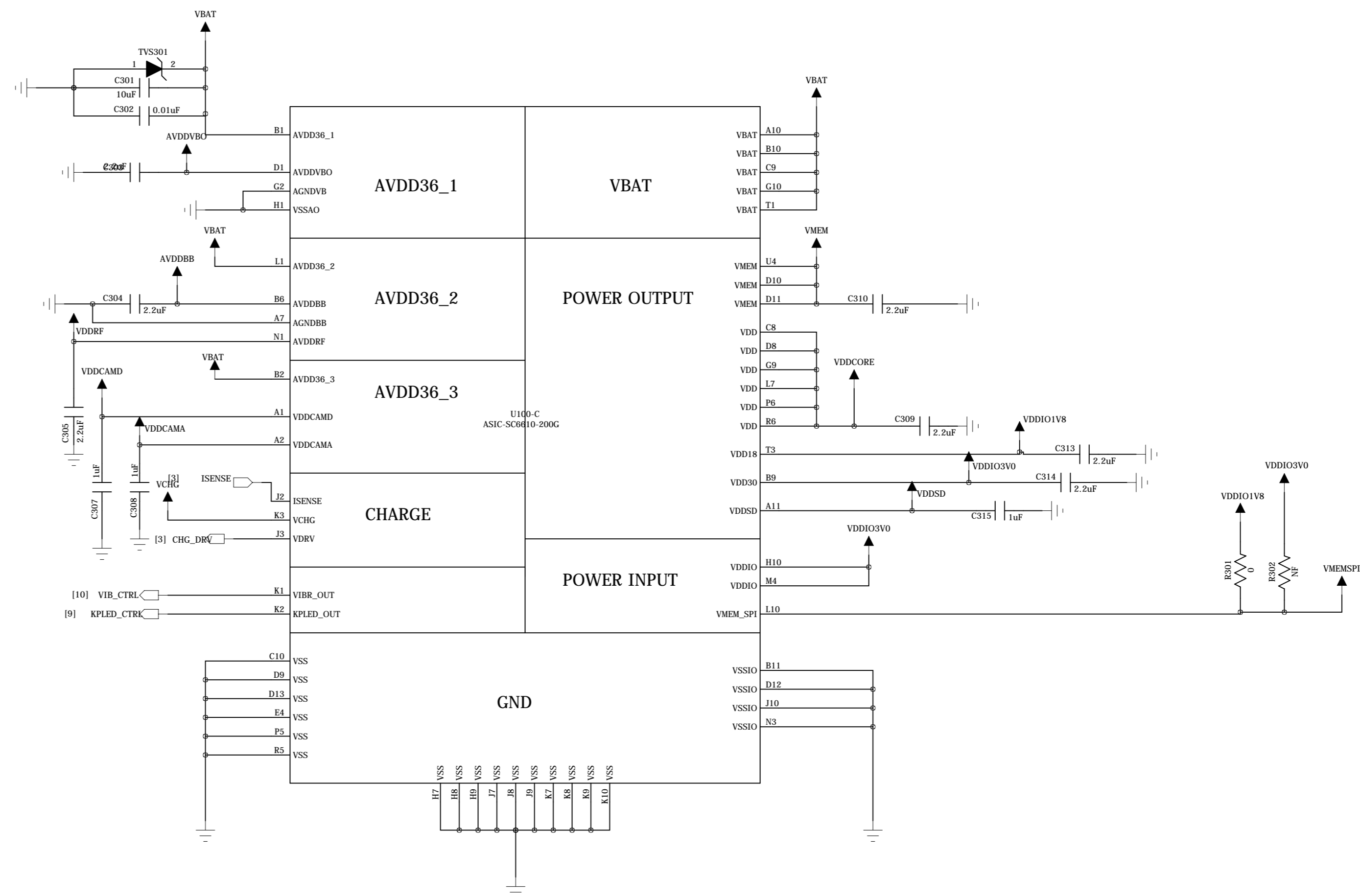
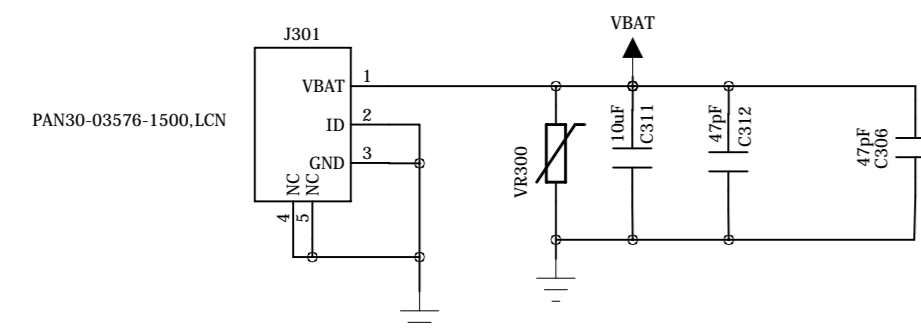

TITLE & REV:
SC6610_PLATFORM_REFERENCE_SCH_V1.0.0.sch

DOCUMENT NO.:
HW-SC6610-SCH-2011-0001

DESIGNER: Franks.Miao	DATED: 2011-02-14	DEPARTMENT: Hardware RD.
EQA: Robin.Zhang	DATED: 2011-02-14	COMPANY: Spreadtrum communications, Inc.
APPROVED: Guobing.Luan	DATED: 2011-02-14	CONFIDENTIAL AND PROPRIETARY

REVISION RECORD			
LTR	ECO NO.	APPROVED:	DATE:

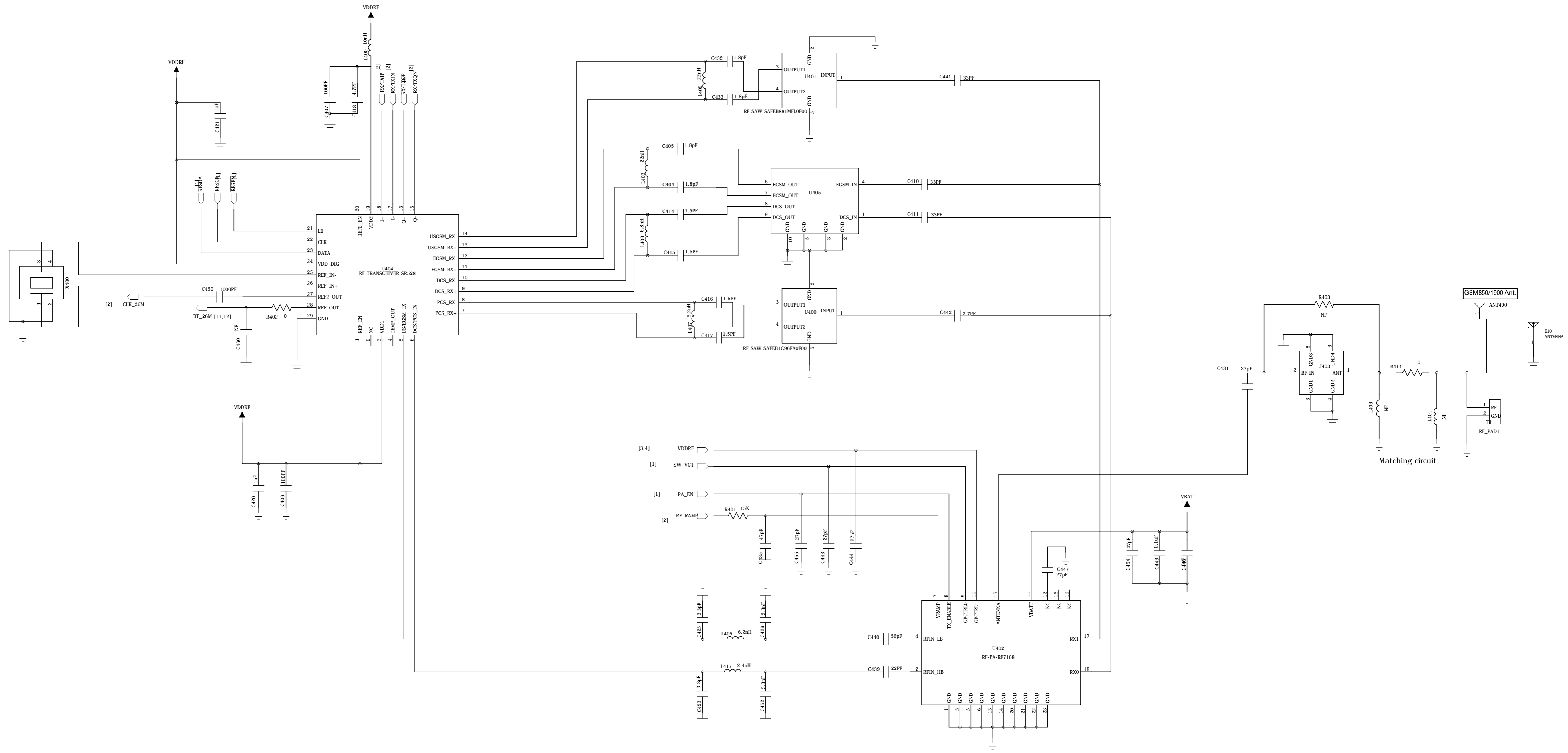

TITLE & REV:
SC6610_PLATFORM_REFERENCE_SCH_V1.0.0.sch

DOCUMENT NO.:
HW-SC6610-SCH-2011-0001

DESIGNER:
Franks.Miao

EQA:
Robin.Zhang

APPROVED:
Guobing.Luan

DATED:
2011-02-14

DATED:
2011-02-14

DATED:
2011-02-14

DEPARTMENT:
Hardware RD.

COMPANY:
Spreadtrum communications, Inc.

CONFIDENTIAL AND PROPRIETARY

SHEET: 4 OF 16

REVISION RECORD			
LTR	ECO NO.	APPROVED	DATE

HEADPHONE

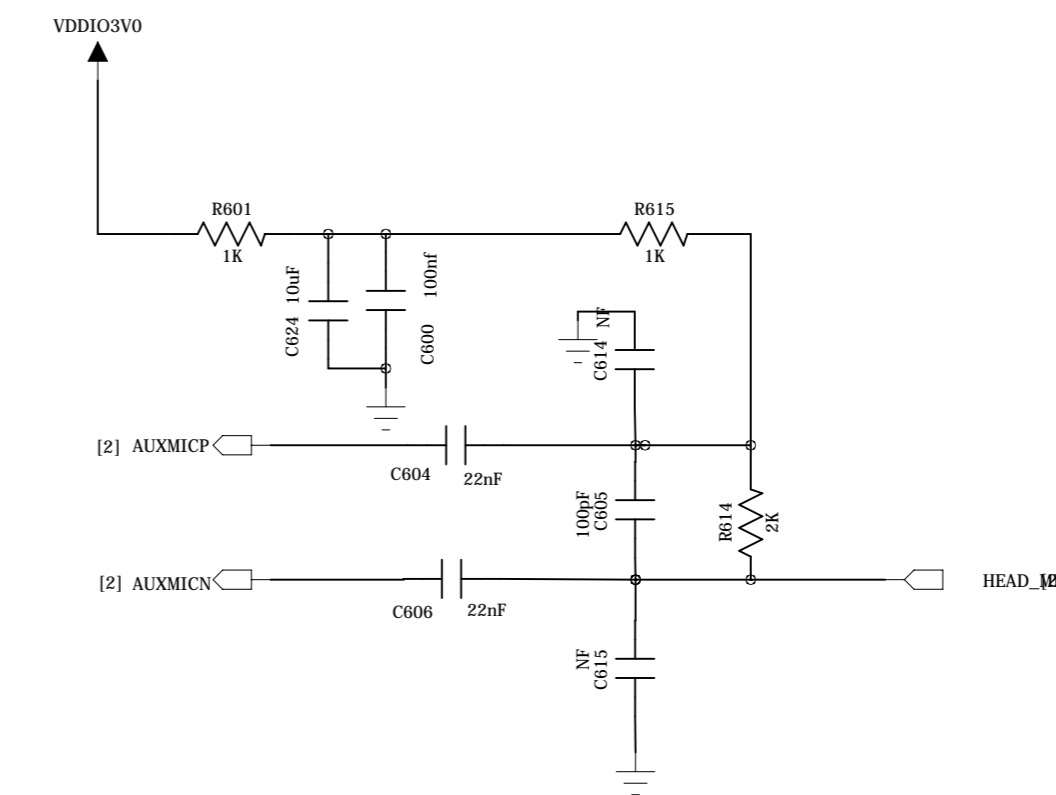

MAIN MIC

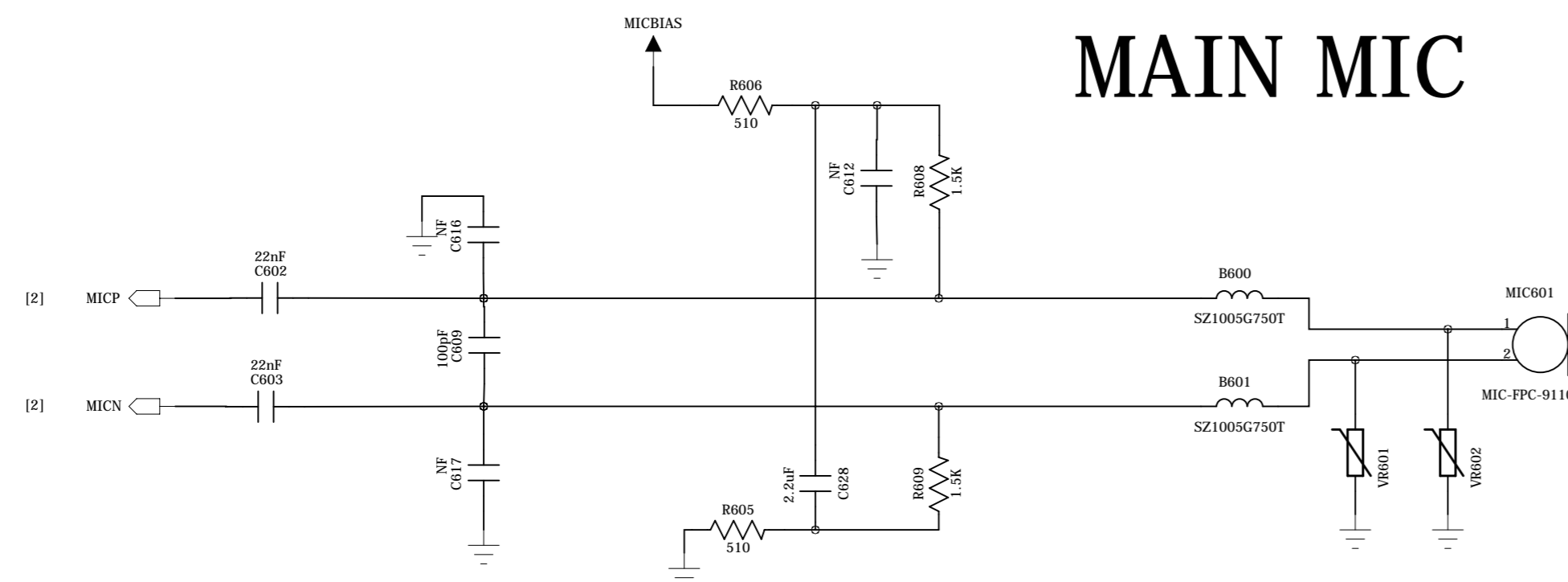

HEADPHONE

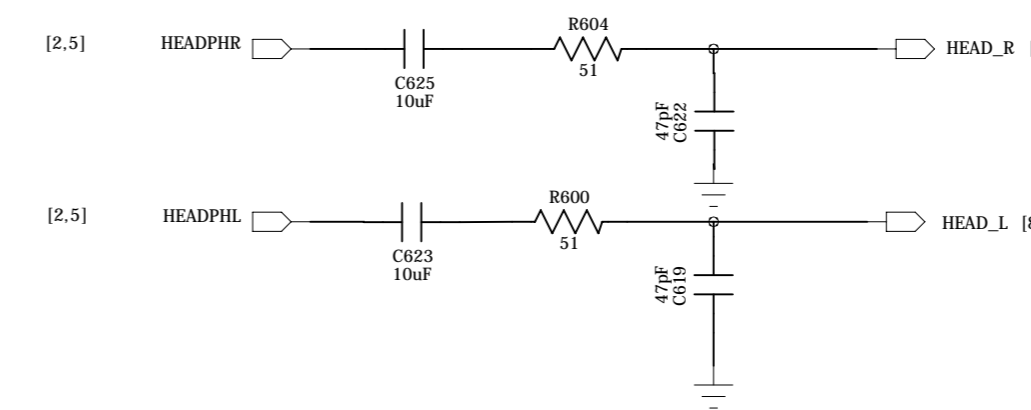

RECEIVER

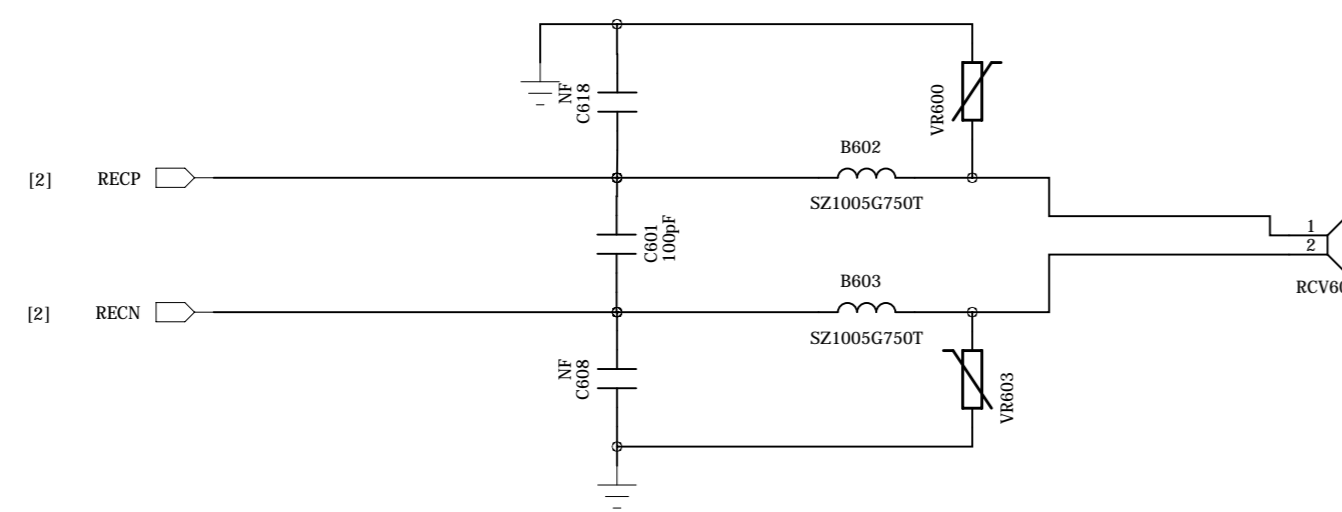

Class AB Speaker

If use combined speaker and receiver ,then Analog switch are needed to prevent reverse current.Pls refer to <<SC6600H Speaker&Receiver Application Notes>>

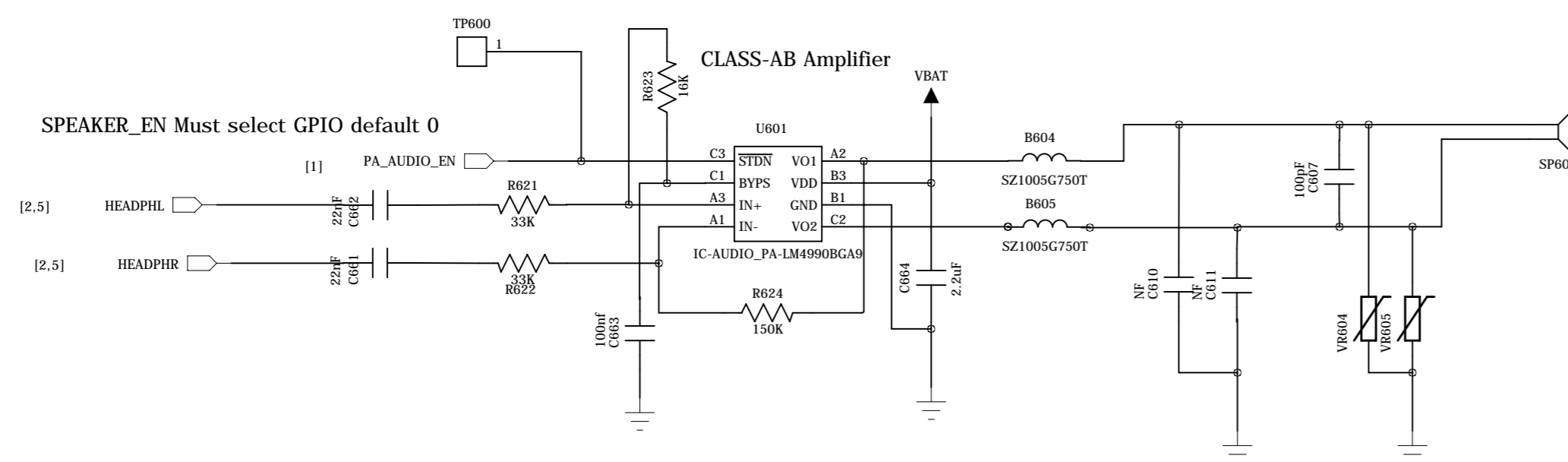

TITLE & REV: SC6610_PLATFORM_REFERENCE_SCH_V1.0.0.sch		
DOCUMENT NO.: HW-SC6610-SCH-2011-0001		
DESIGNER: Franks.Miao	DATED: 2011-02-14	DEPARTMENT: Hardware RD.
EQA: Robin.Zhang	DATED: 2011-02-14	COMPANY: Spreadtrum communications, Inc.
APPROVED: Guobing.Luan	DATED: 2011-02-14	CONFIDENTIAL AND PROPRIETARY

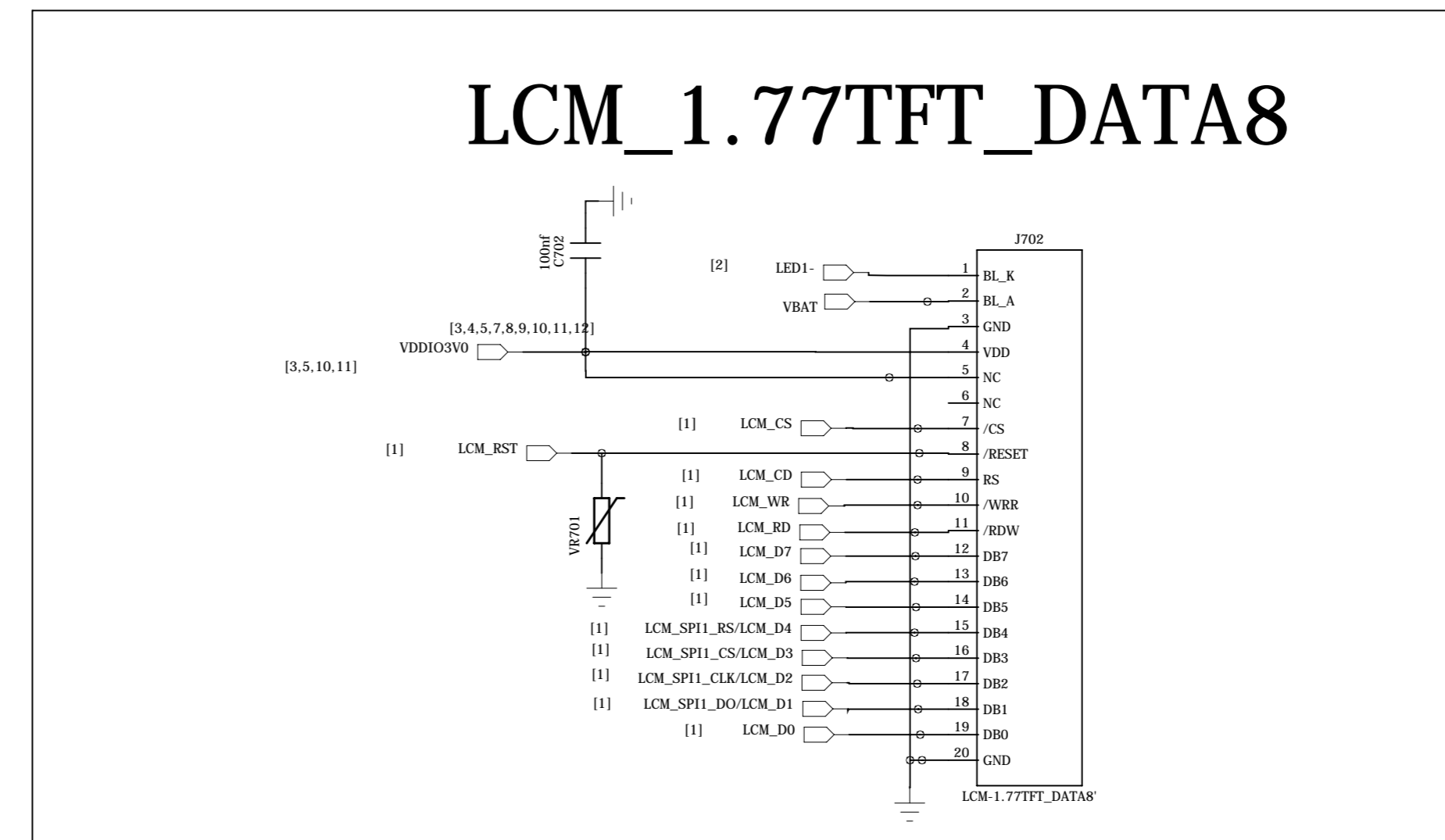
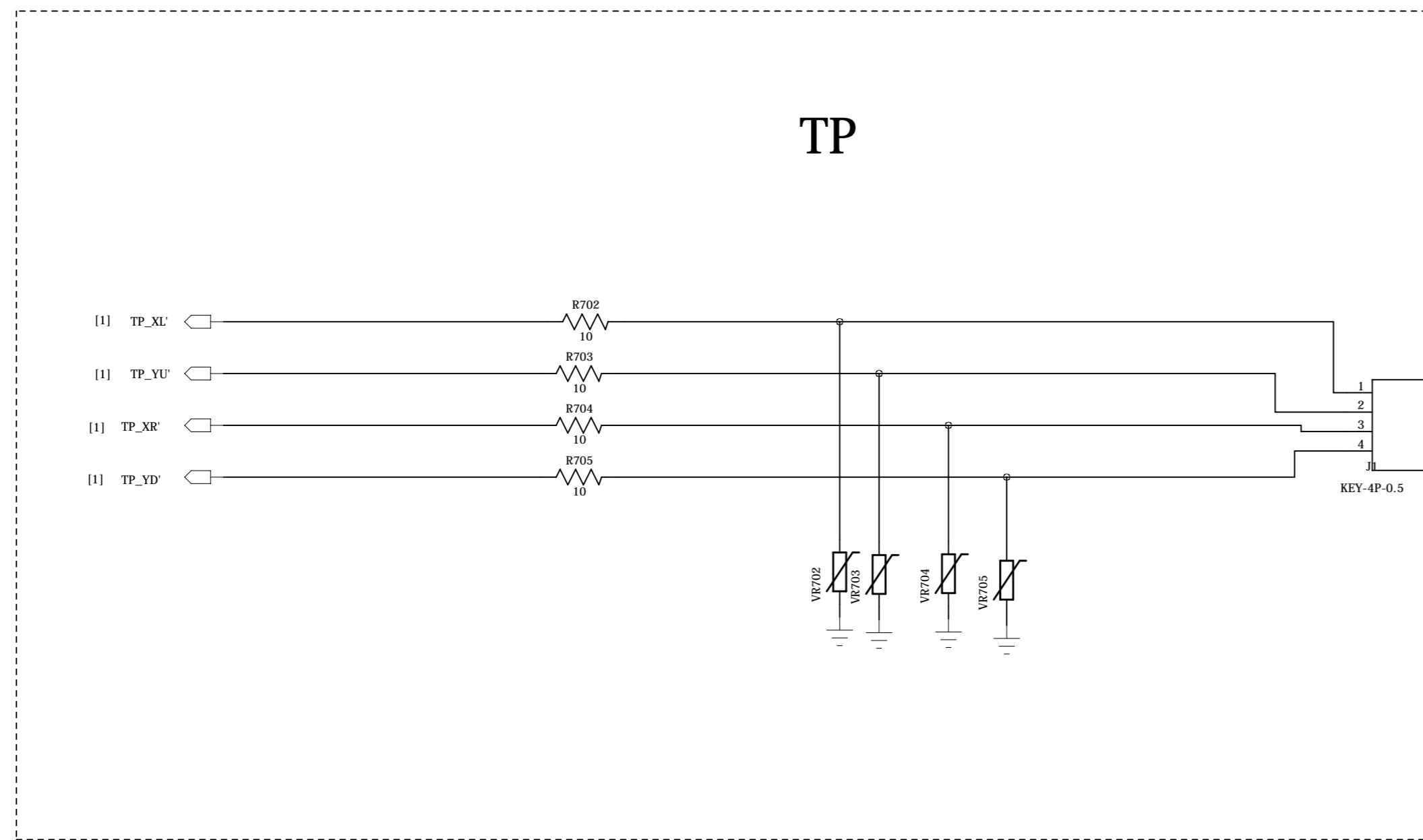

REVISION RECORD			
LTR	ECO NO.	APPROVED:	DATE:

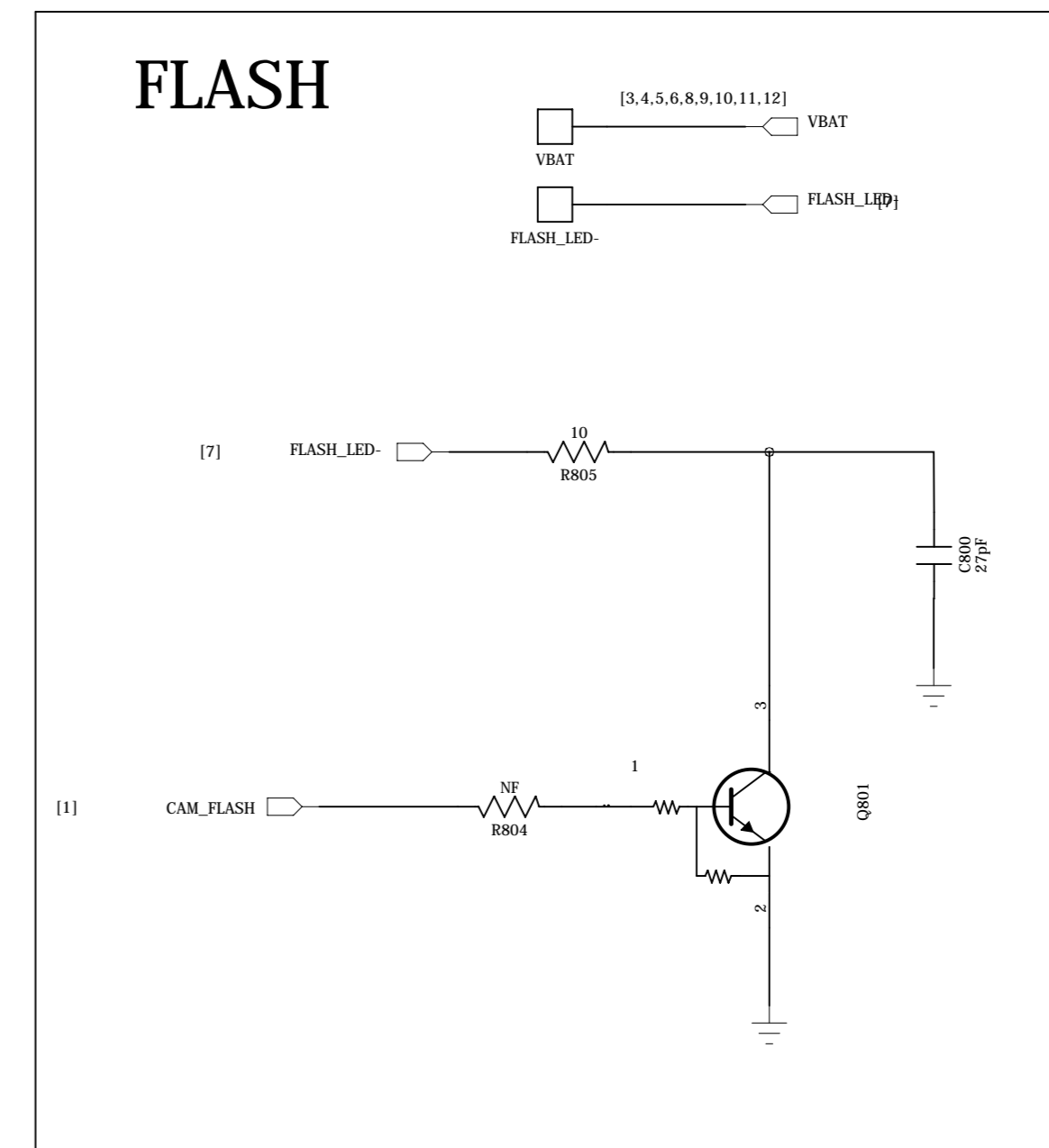
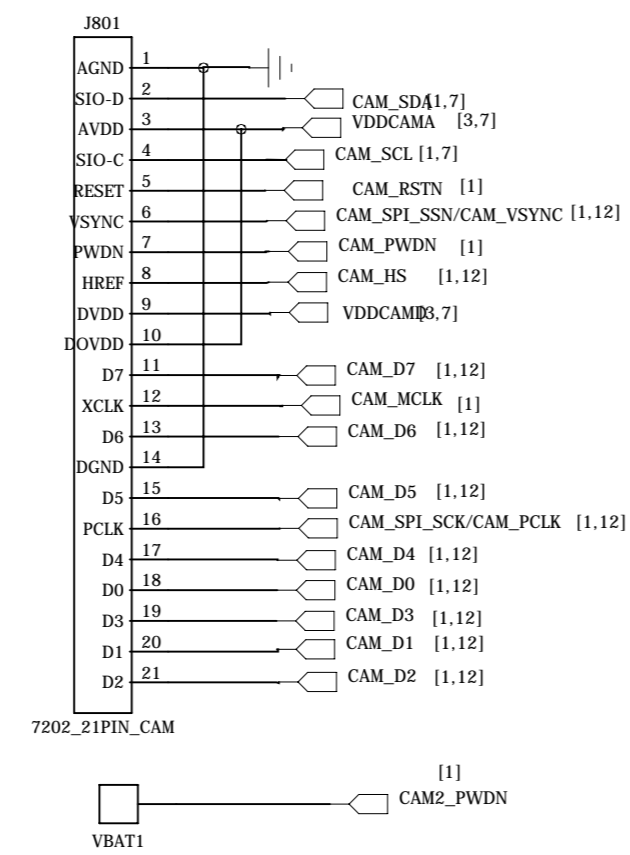
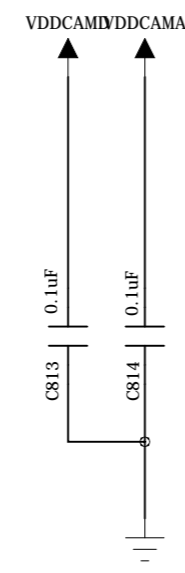
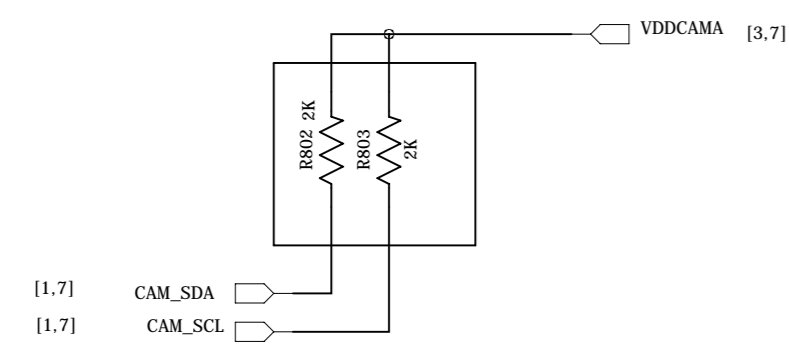

TITLE & REV:	SC6610_PLATFORM_REFERENCE_SCH_V1.0.0.sch
DOCUMENT NO.:	HW-SC6610-SCH-2011-0001

DESIGNER: Franks.Miao	DATED: 2011-02-14	DEPARTMENT: Hardware RD.
EQA: Robin.Zhang	DATED: 2011-02-14	COMPANY: Spreadtrum communications, Inc.
APPROVED: Guobing.Luan	DATED: 2011-02-14	CONFIDENTIAL AND PROPRIETARY

REVISION RECORD			
LTR	ECO NO:	APPROVED:	DATE:

Boot select:
 UORTSN/NBOOT/U1TXD = low --> boot from USB
 UORTSN/NBOOT/U1TXD = high --> boot from NOR or UART

UOCTSN is used as U1RXD
 UORTSN is used as U1TXD and NBOOT

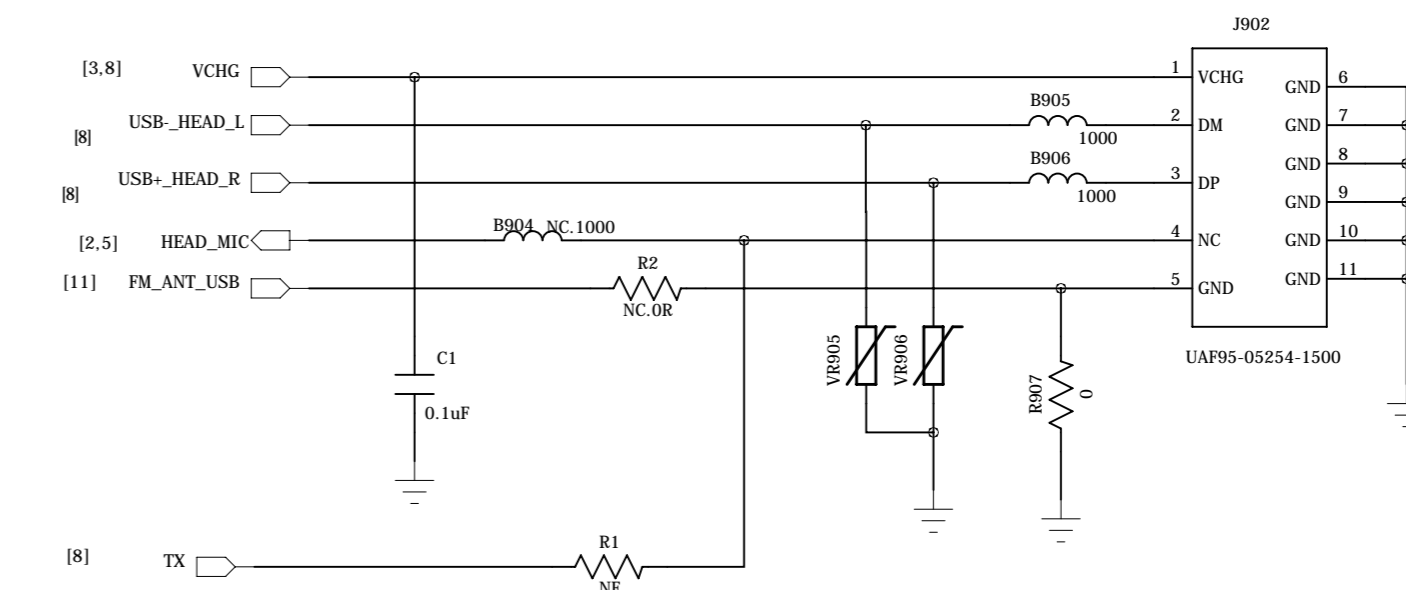
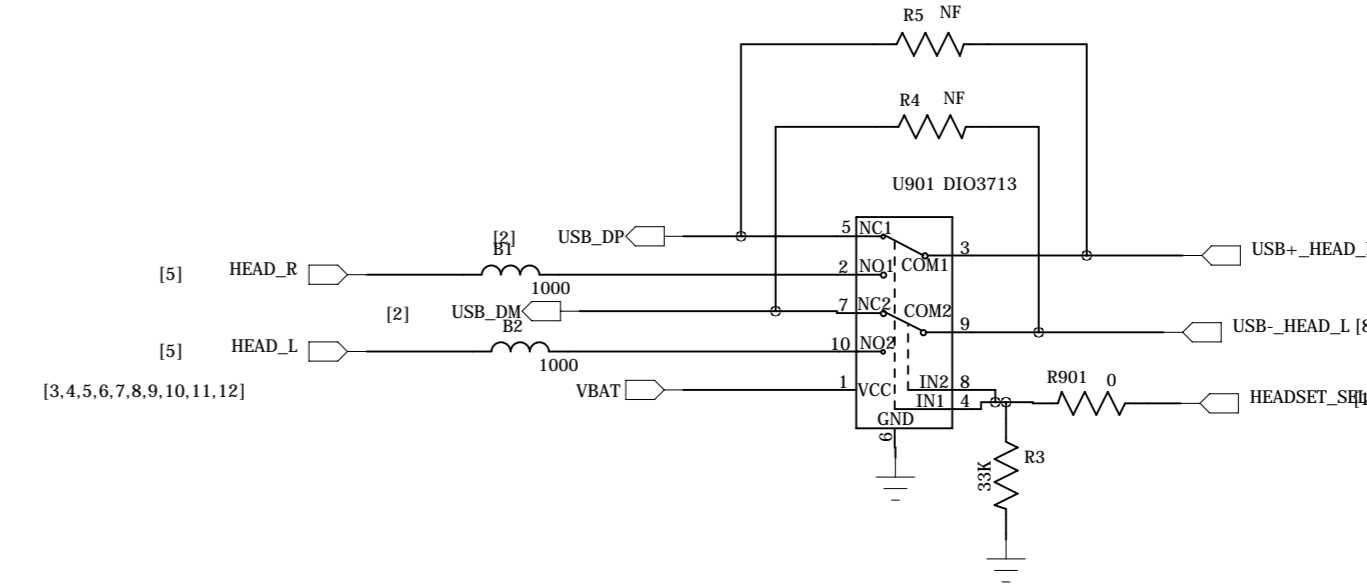
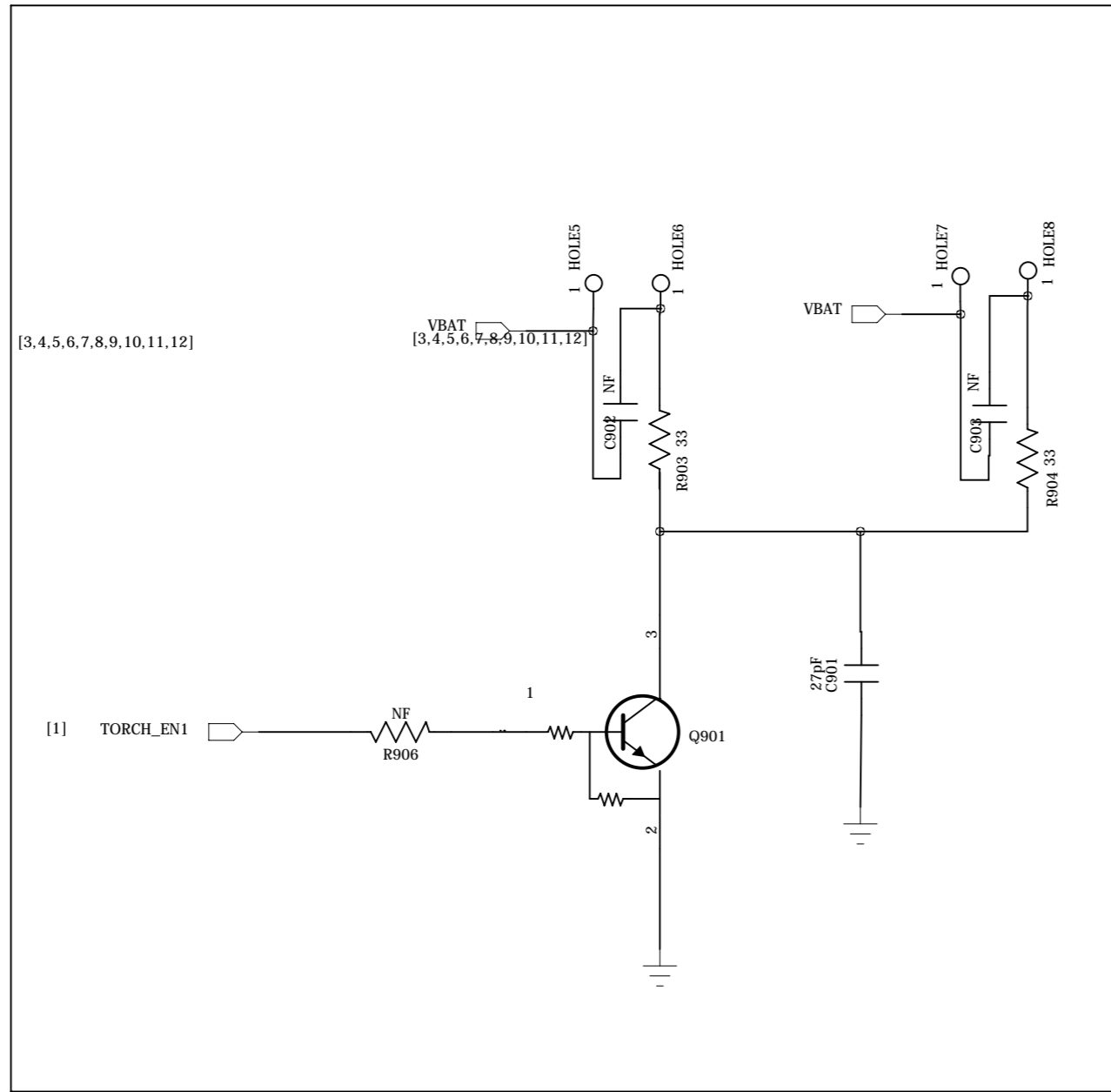

D

C

B

A

D

C

B

A

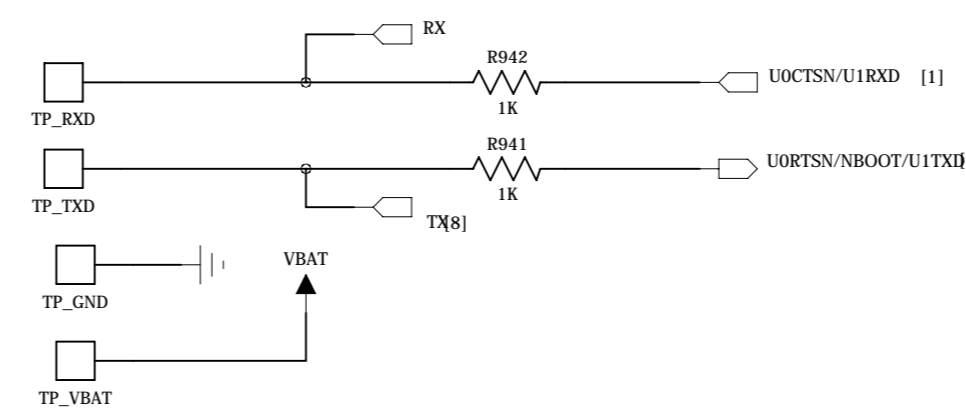
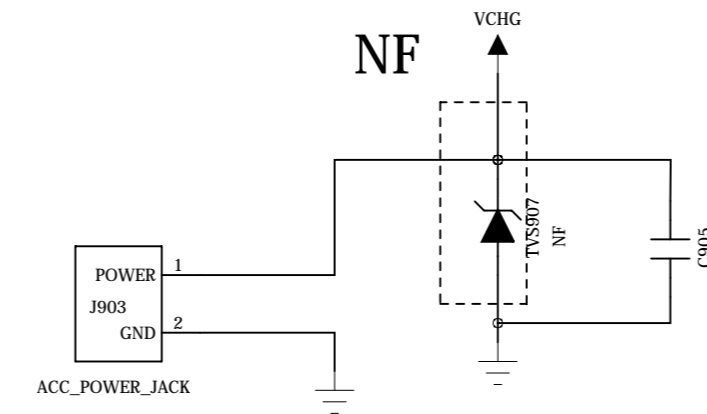
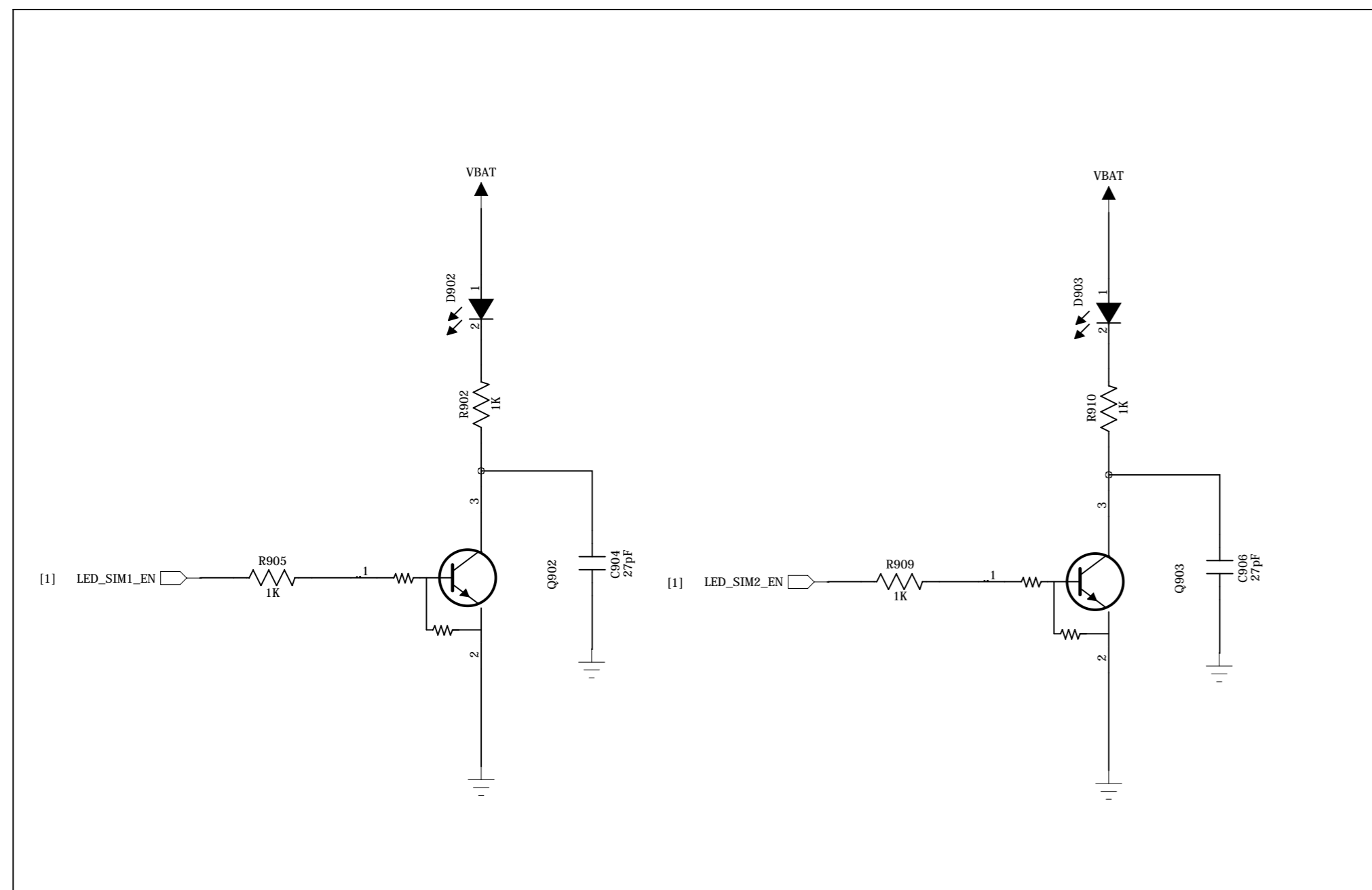

MARK point

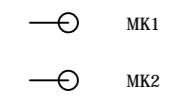

TITLE & REV:
SC6610_PLATFORM_REFERENCE_SCH_V1.0.0.sch
 DOCUMENT NO.:
HW-SC6610-SCH-2011-0001

DESIGNER: Franks.Miao	DATED: 2011-02-14
EQA: Robin.Zhang	DATED: 2011-02-14
APPROVED: Guobing.Luan	DATED: 2011-02-14

DEPARTMENT: Hardware RD.
COMPANY: Spreadtrum communications, Inc.
CONFIDENTIAL AND PROPRIETARY

REVISION RECORD			
LTR	ECO NO.	APPROVED:	DATE:

KEYPAD

Press this button when power up will make the phone boot from USB

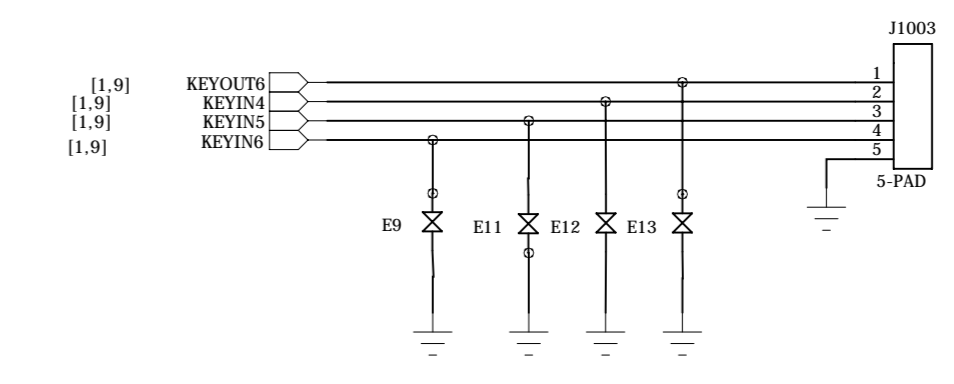
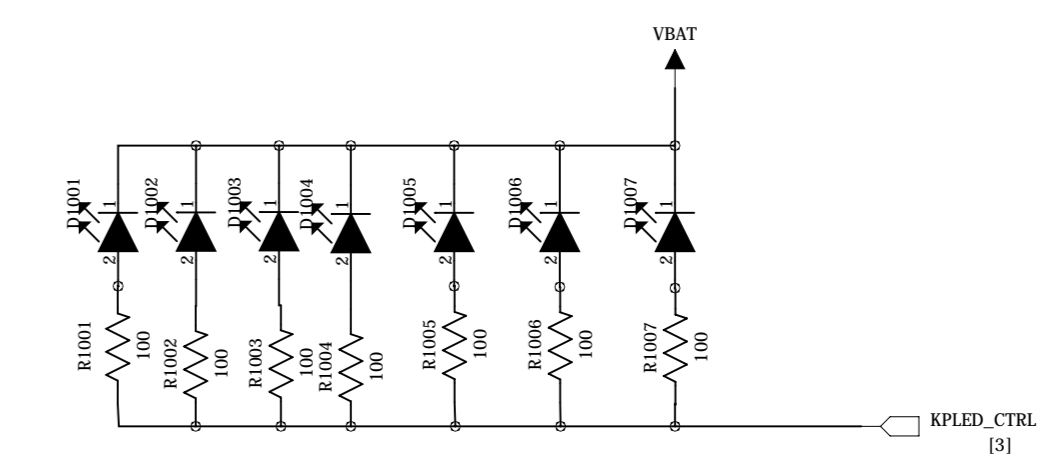
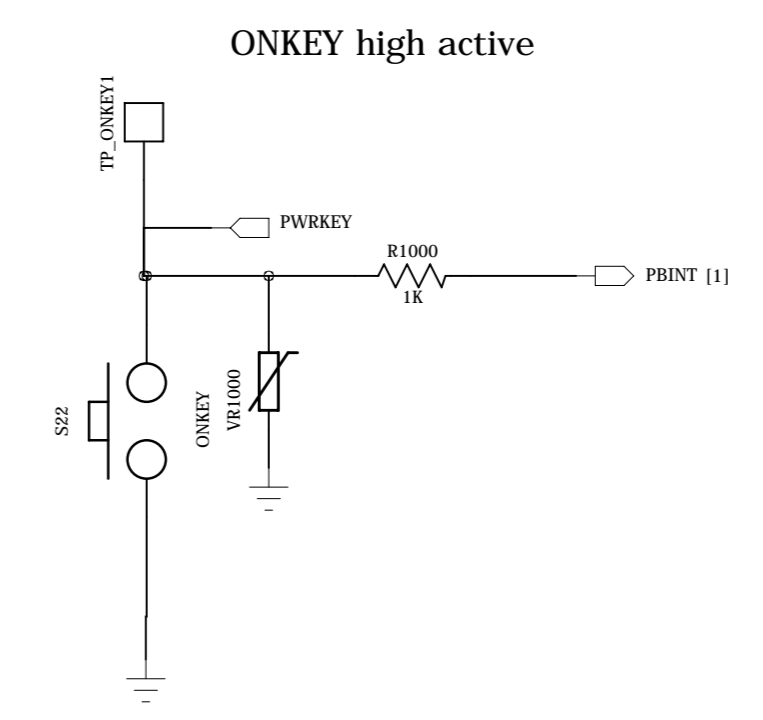
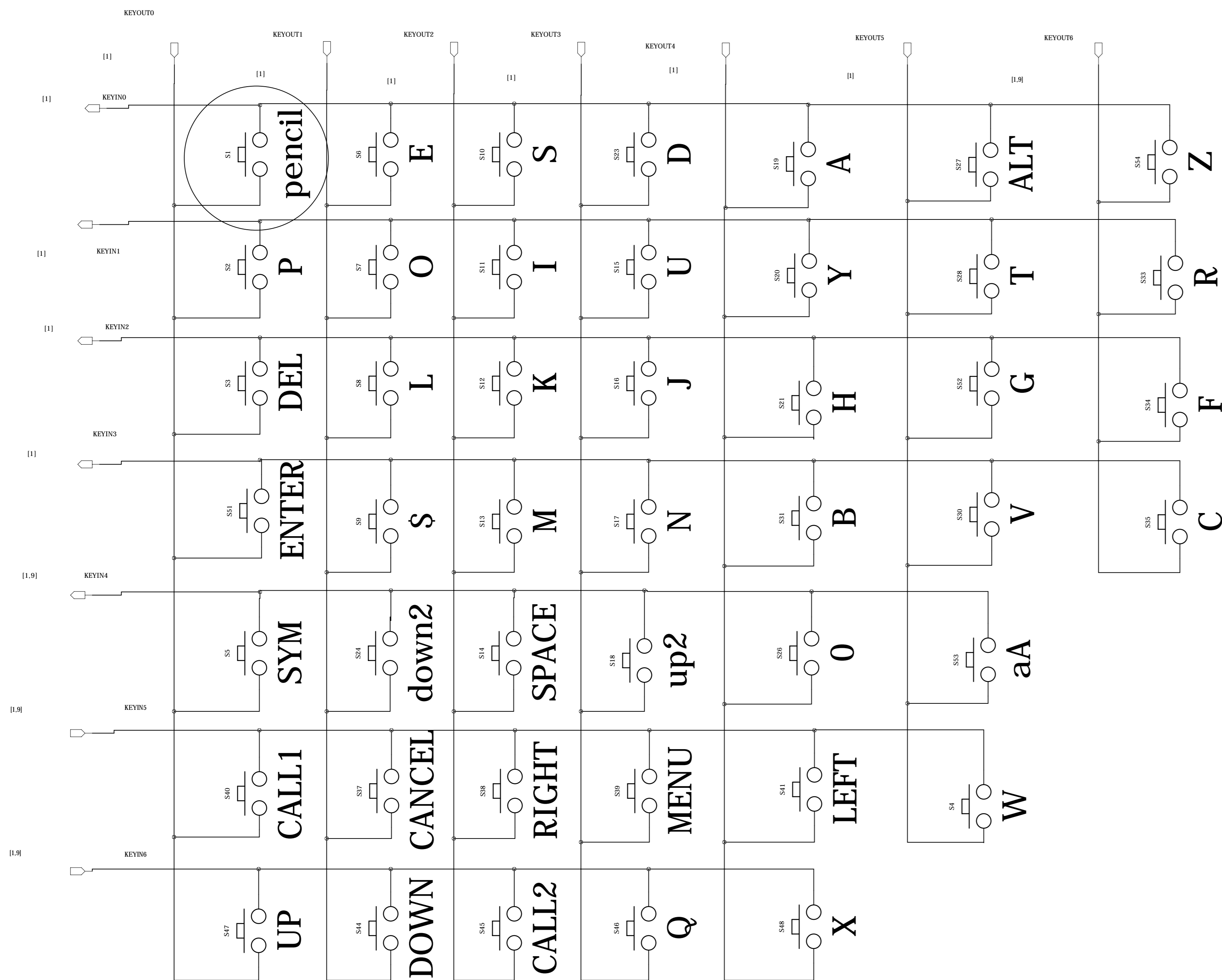

TITLE & REV: SC6610_PLATFORM_REFERENCE_SCH_V1.0.0.sch	
DOCUMENT NO.: HW-SC6610-SCH-2011-0001	
DESIGNER: Franks.Miao	DATED: 2011-02-14
EQA: Robin.Zhang	DATED: 2011-02-14
APPROVED: Cuobing.Luan	DATED: 2011-02-14
DEPARTMENT: Hardware RD.	
COMPANY: Spreadtrum communications, Inc.	
CONFIDENTIAL AND PROPRIETARY	
SHEET: 11 OF 16	

REVISION RECORD			
LTR	ECO NO:	APPROVED:	DATE:

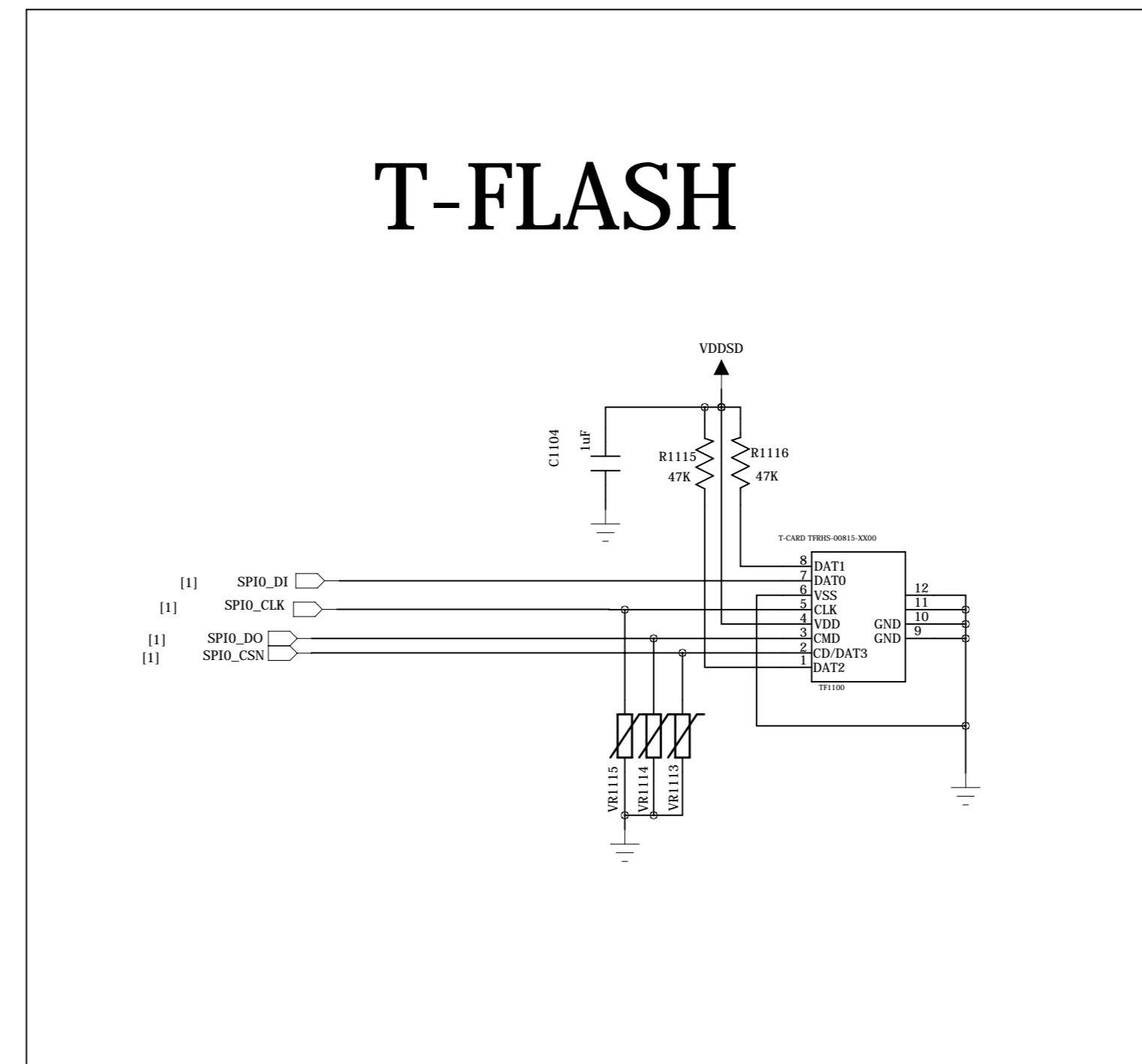
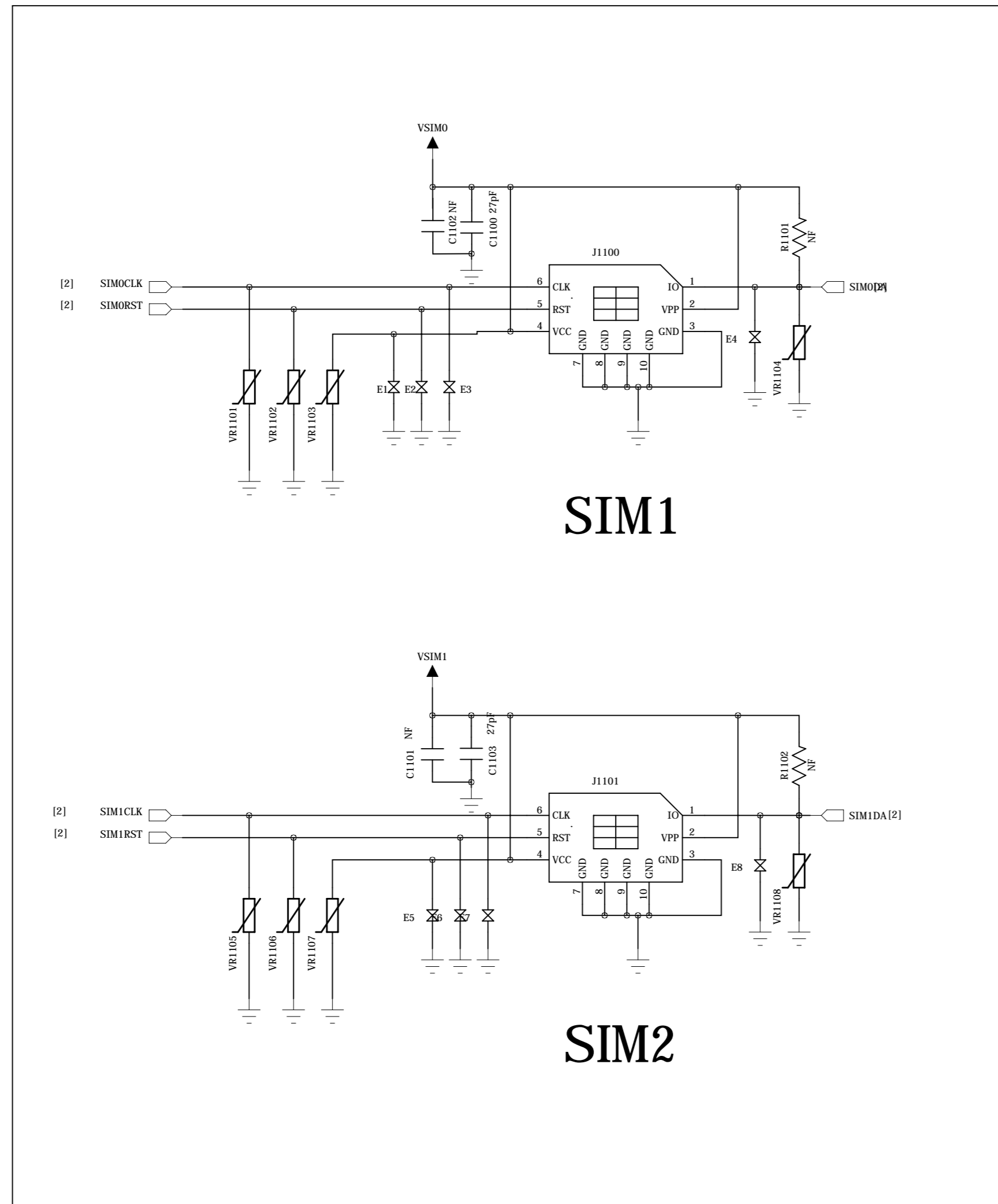
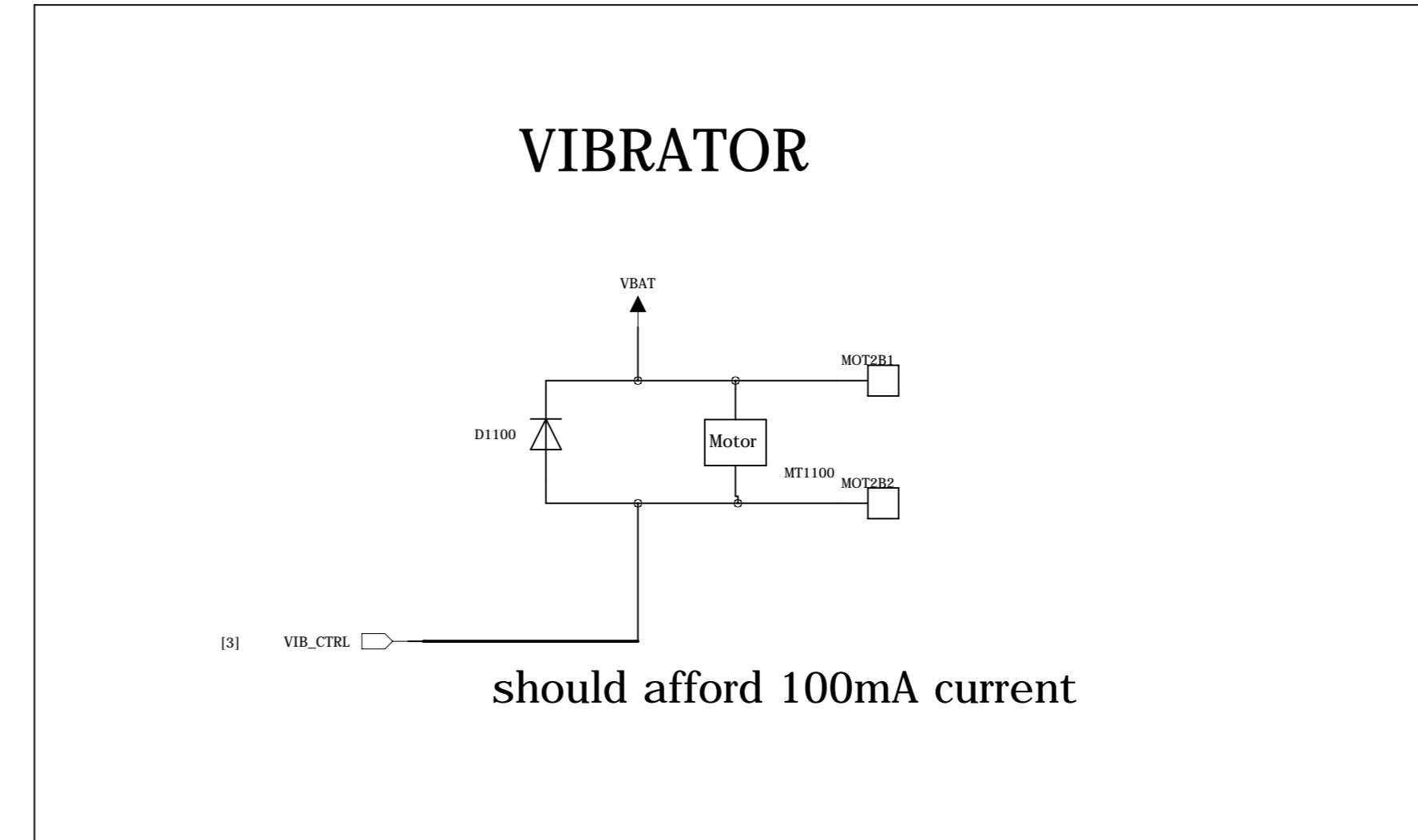
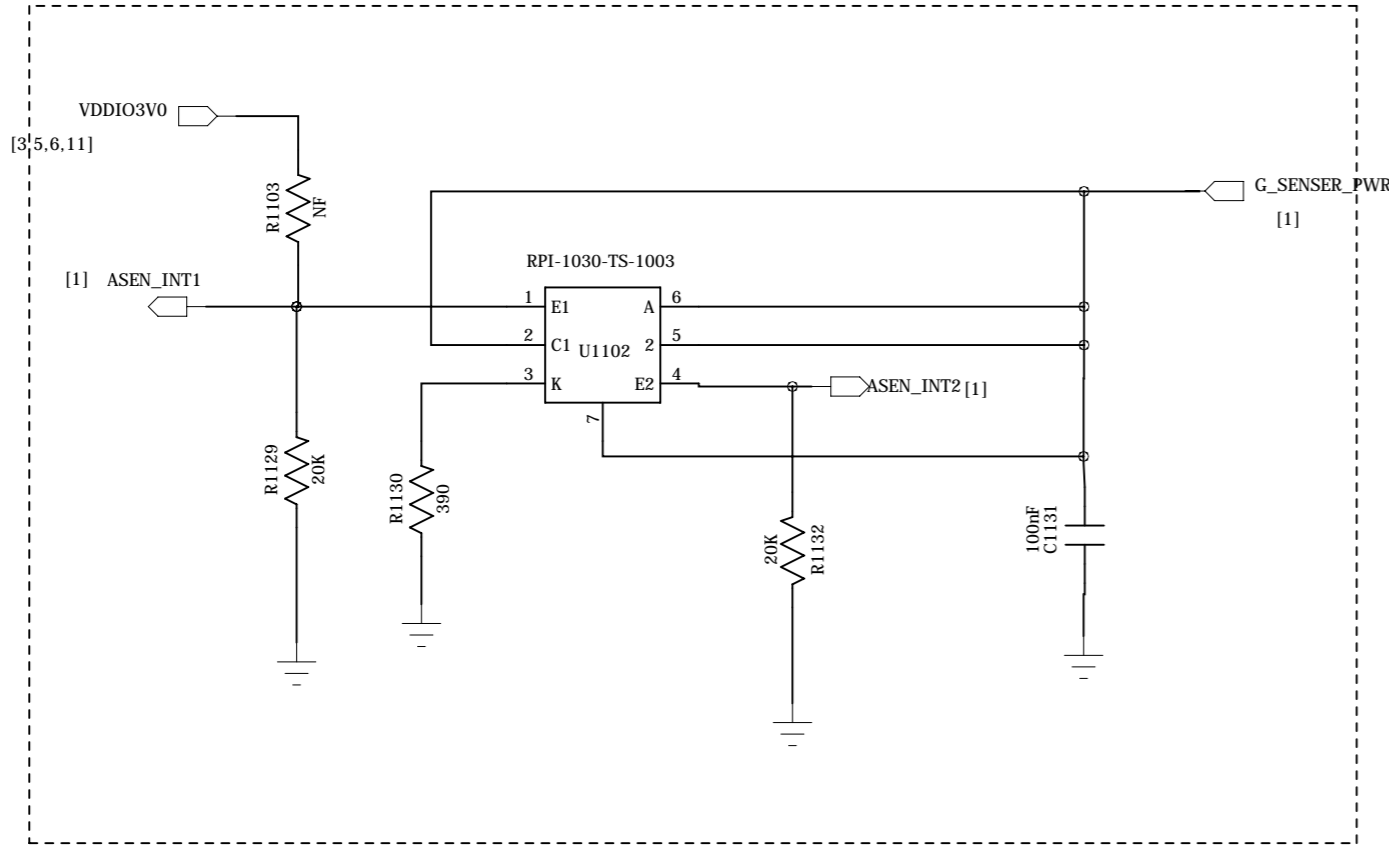

TITLE & REV:		SC6610_PLATFORM_REFERENCE_SCH_V1.0.0.sch	
DOCUMENT NO.:		HW-SC6610-SCH-2011-0001	

DESIGNER: Franks.Miao	DATED: 2011-02-14	DEPARTMENT: Hardware RD.
EQA: Robin.Zhang	DATED: 2011-02-14	COMPANY: Spreadtrum communications, Inc.
APPROVED: Guobing.Luan	DATED: 2011-02-14	CONFIDENTIAL AND PROPRIETARY

REVISION RECORD			
LTR	ECO NO.	APPROVED:	DATE:

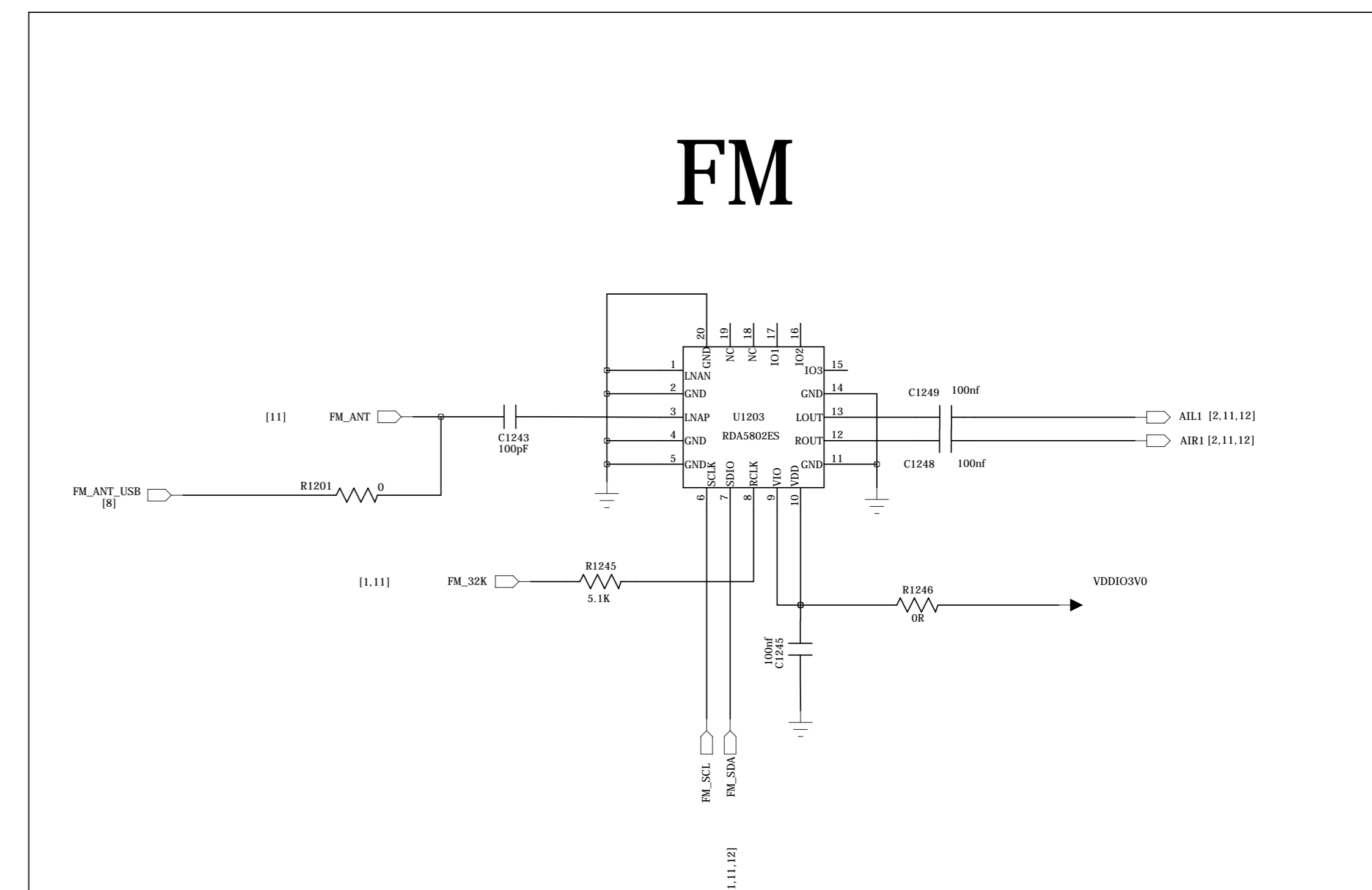
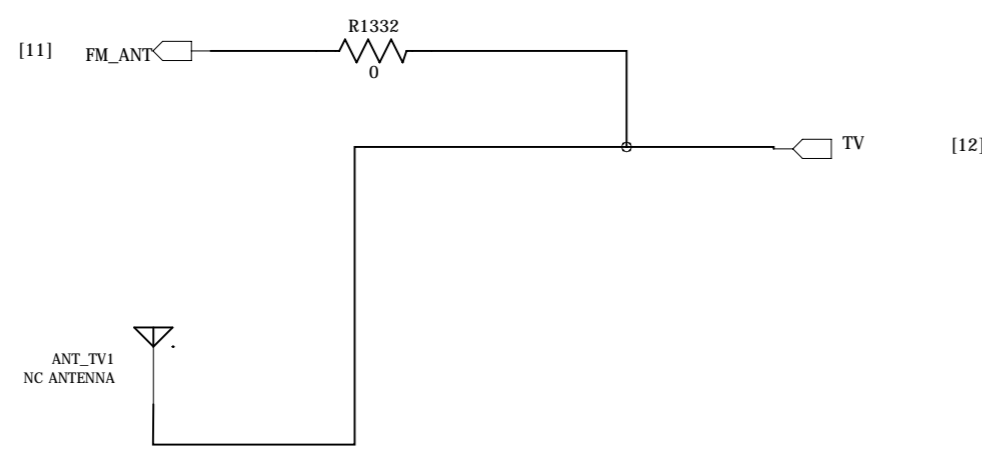
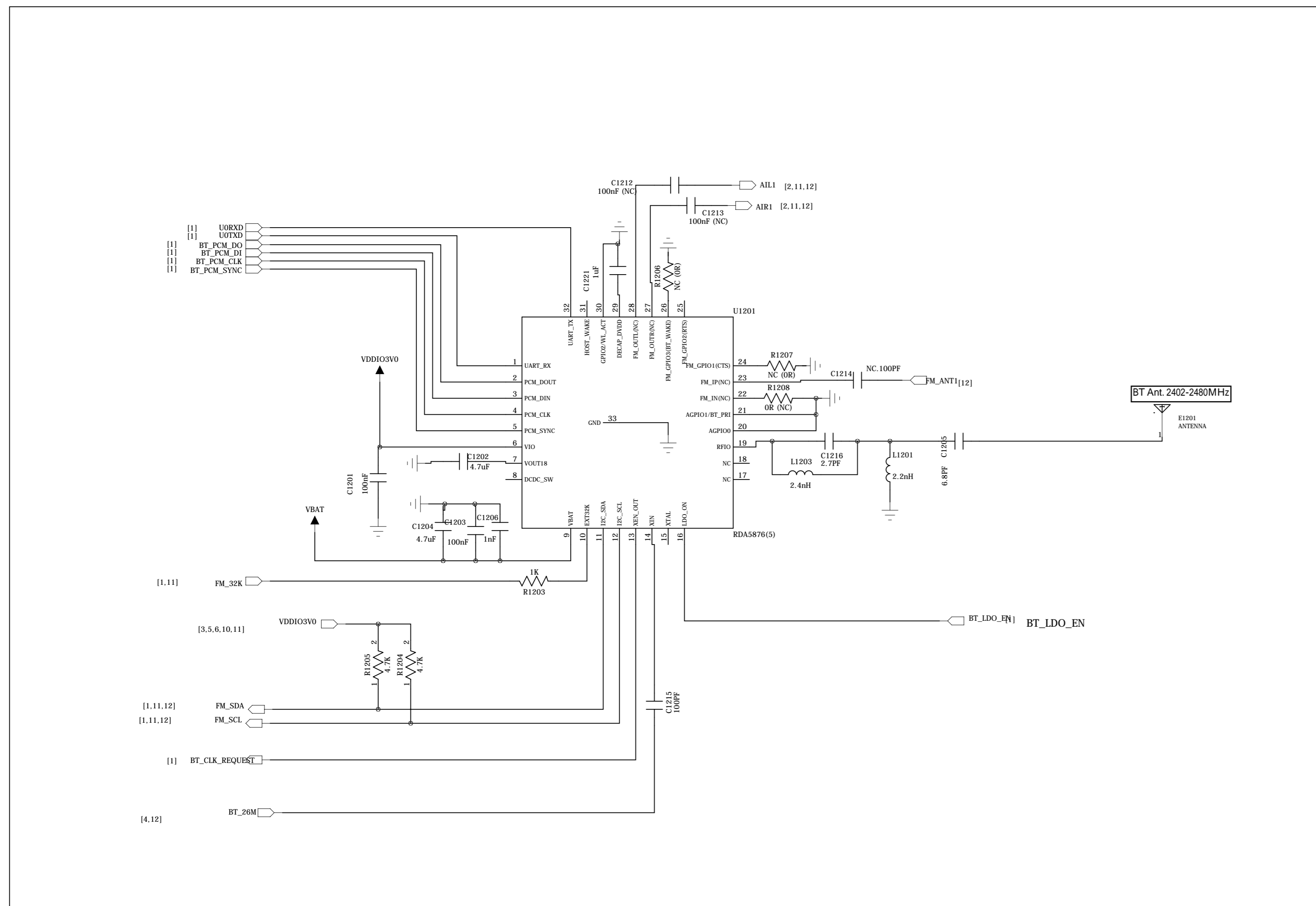

TITLE & REV: SC6610_PLATFORM_REFERENCE_SCH_V1.0.0.sch	
DOCUMENT NO.:	
DESIGNER:	DATED:
EQA:	DATED:
APPROVED:	DATED:
DEPARTMENT: Hardware RD.	
COMPANY: Spreadtrum communications, Inc.	
CONFIDENTIAL AND PROPRIETARY	

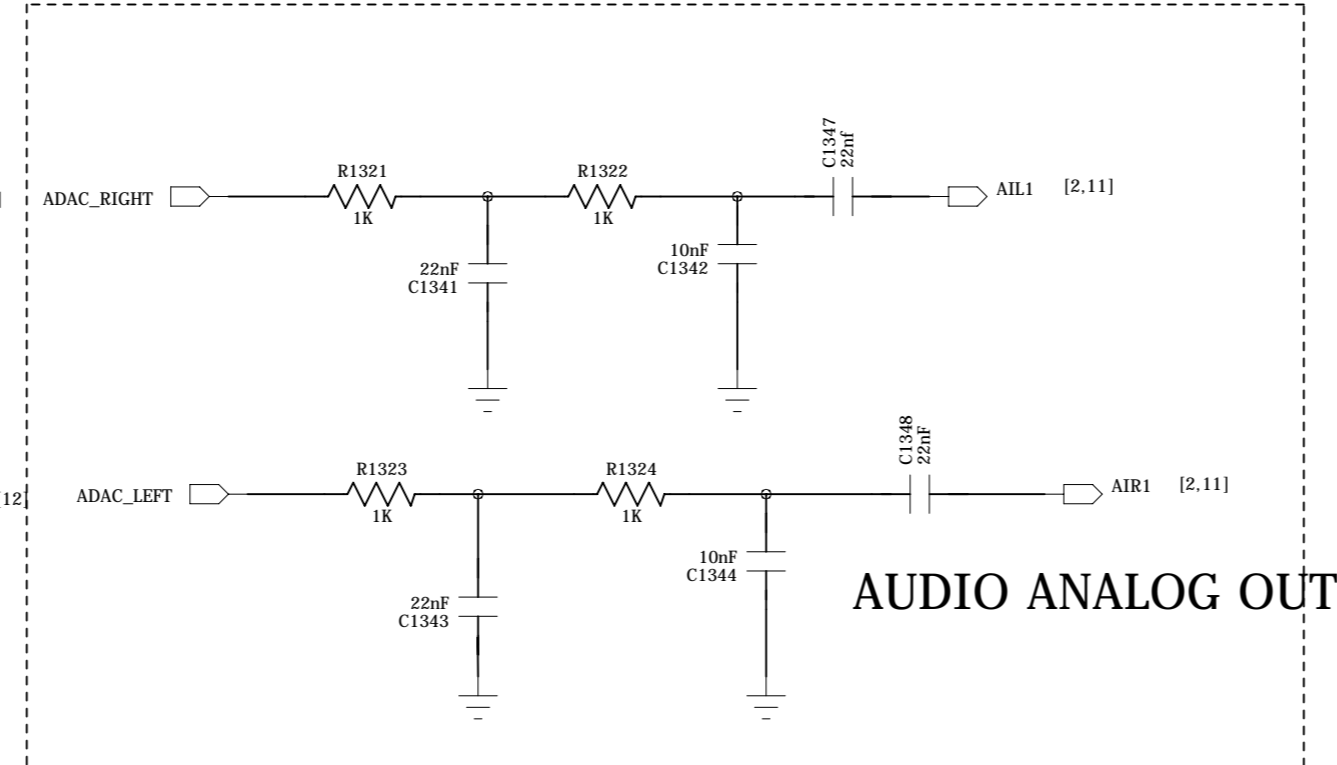
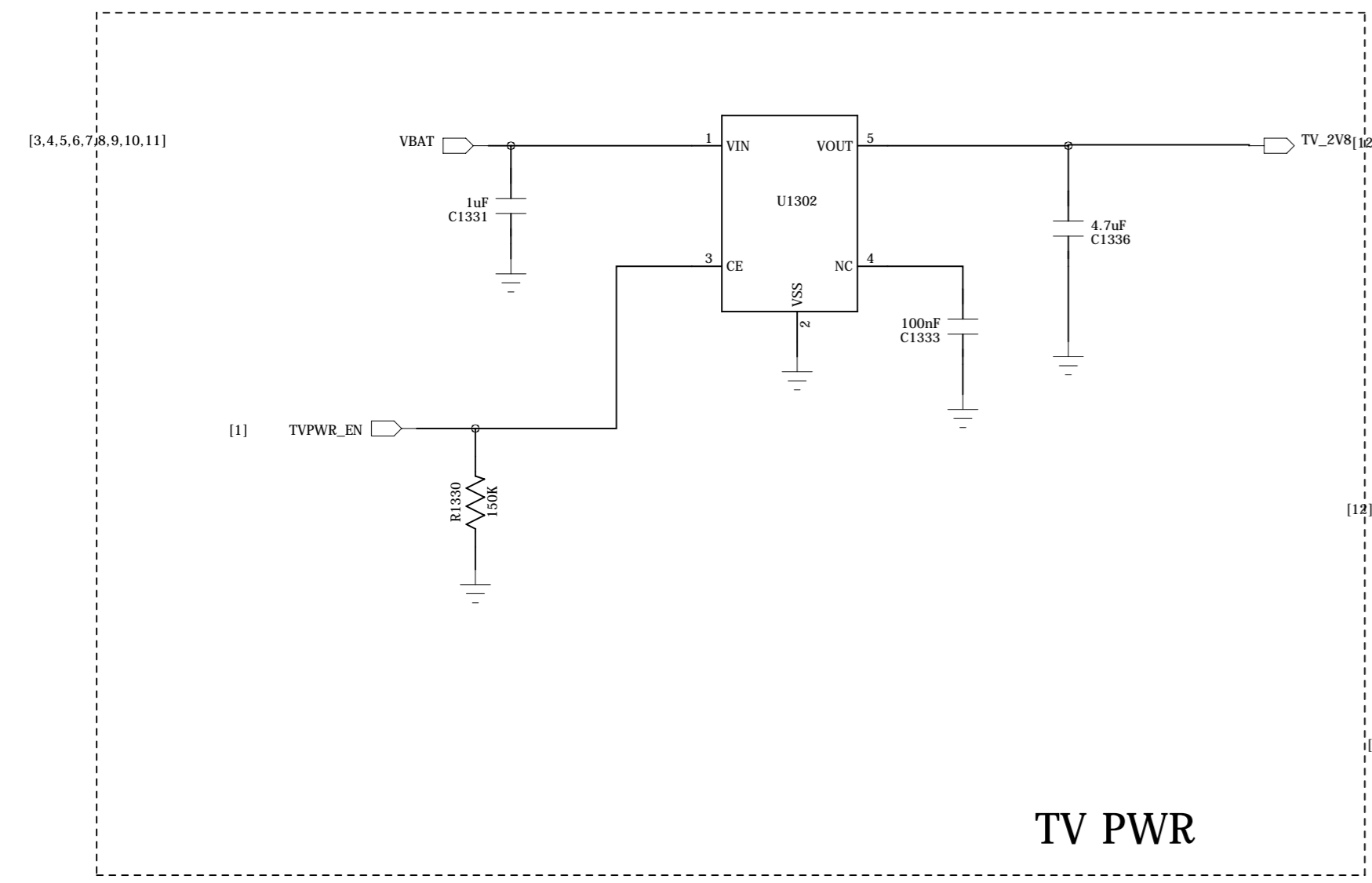
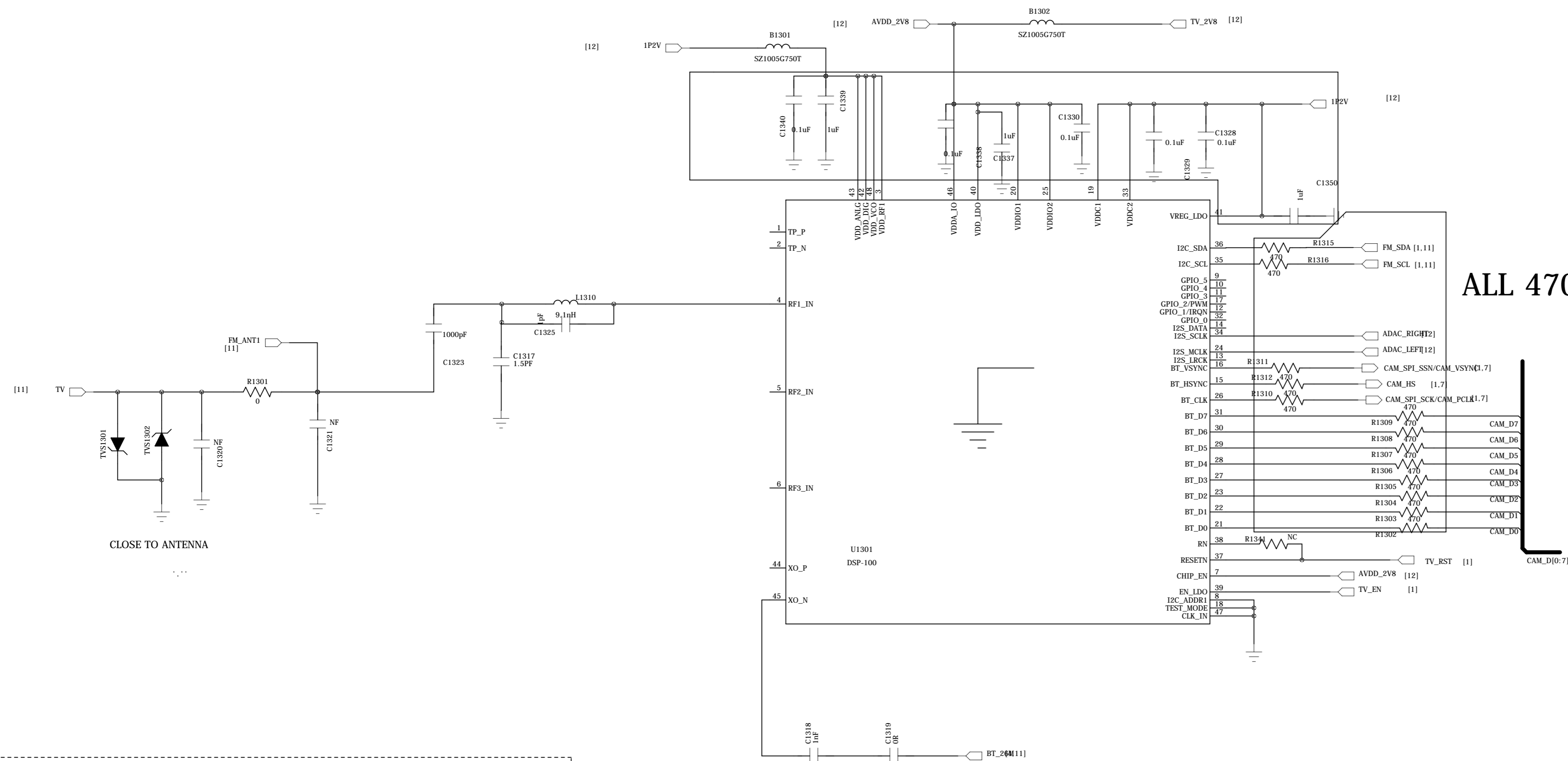

Freecom	
Project £ ° <project>	Design by £ & Design >
Title £ ° <title>	Check by £ & check >
REV £ ° <REV>	Approve £ & appr >
File NO. £ ° <file no>	sheet: 12 / 12