



Telephone: +86 (0) 755 2779 8480  
Fax: +86 (0) 755 2779 8960  
Email: szsale@gtstest.com

Report No.: GTSE10070011001  
Page: 1 of 54

## ELECTROMAGNETIC EMISSIONS COMPLIANCE REPORT

<b>Application No:</b>	GTSE100700110RF
<b>Applicant:</b>	Verykool USA Inc.
<b>Address of Applicant:</b>	4350 Executive Drive. Suite 100, San Diego, CA 92121, USA
<b>Equipment Under Test (EUT)</b>	
<b>Name:</b>	GSM Dual Band GPRS Digital Mobile Phone
<b>Model No.:</b>	i600
<b>Trademark:</b>	verykool
<b>FCC ID:</b>	WA6I600
<b>Standards:</b>	FCC CFR Title 47 Part 2, Part22H &24E
<b>Date of Receipt:</b>	25 July, 2010
<b>Date of Test:</b>	25~30 July, 2010
<b>Date of Issue:</b>	31 July, 2010
<b>Test Result :</b>	<b>PASS *</b>

\* In the configuration tested, the EUT complied with the standards specified above.

Authorized Signature:

Robinson Lo  
Laboratory Manager

This report details the results of the testing carried out on one sample. The results contained in this test report do not relate to other samples of the same product and does not permit the use of the GTS product certification mark. The manufacturer should ensure that all products in series production are in conformity with the product sample detailed in this report.

This report may only be reproduced and distributed in full. If the product in this report is used in any configuration other than that detailed in the report, the manufacturer must ensure the new system complies with all relevant standards. Any mention of GTS International Electrical Approvals or testing done by GTS International Electrical Approvals in connection with, distribution or use of the product described in this report must be approved by GTS International Electrical Approvals in writing.

This document cannot be reproduced except in full, without prior written approval of the Company. Any unauthorized alteration, forgery or falsification of the content or appearance of this document is unlawful and offenders may be prosecuted to the fullest extent of the law. Unless otherwise stated the results shown in this test report refer only to the sample(s) tested and such sample(s) are retained for 90 days only."

## 2 Contents

Page

<b>1</b>	<b>COVER PAGE</b> .....	<b>1</b>
<b>2</b>	<b>CONTENTS</b> .....	<b>2</b>
<b>3</b>	<b>TEST SUMMARY</b> .....	<b>4</b>
<b>4</b>	<b>GENERAL INFORMATION</b> .....	<b>5</b>
4.1	CLIENT INFORMATION .....	5
4.2	GENERAL DESCRIPTION OF E.U.T.....	5
4.3	RELATED SUBMITTAL(S) / GRANT (S) .....	5
4.4	TEST METHODOLOGY .....	5
4.5	TEST FACILITY.....	6
4.6	TEST LOCATION.....	6
4.7	TEST INSTRUMENTS LIST.....	7
<b>5</b>	<b>SYSTEM TEST CONFIGURATION</b> .....	<b>8</b>
5.1	EUT CONFIGURATION: .....	8
5.2	EUT EXERCISE .....	8
5.3	TEST PROCEDURE .....	8
5.3.1	Conducted Emissions.....	8
5.3.2	Radiated Emissions.....	8
5.4	CONFIGURATION OF TESTED SYSTEM .....	8
5.5	DESCRIPTION OF TEST MODES.....	9
<b>6</b>	<b>RF POWER OUTPUT MEASUREMENT</b> .....	<b>10</b>
6.1	STANDARD APPLICABLE .....	10
6.2	TEST SETUP.....	10
6.3	MEASUREMENT PROCEDURE .....	10
6.4	TEST RESULT .....	10
<b>7</b>	<b>ERP, EIRP MEASUREMENT</b> .....	<b>14</b>
7.1	STANDARD APPLICABLE .....	14
7.2	TEST SET-UP (BLOCK DIAGRAM OF CONFIGURATION).....	14
7.3	MEASUREMENT PROCEDURE .....	15
7.4	MEASUREMENT RESULT .....	16
<b>8</b>	<b>MODULATION CHARACTERISTIC</b> .....	<b>18</b>
<b>9</b>	<b>OCCUPIED BANDWIDTH</b> .....	<b>19</b>
9.1	STANDARD APPLICABLE .....	19
9.2	TEST SETUP.....	19
9.3	TEST PROCEDURE .....	19
9.4	TEST RESULT .....	19
<b>10</b>	<b>OUT OF BAND EMISSION AT ANTENNA TERMINALS</b> .....	<b>26</b>
10.1	STANDARD APPLICABLE .....	26
10.2	TEST SETUP.....	26
10.3	MEASUREMENT PROCEDURE .....	26
10.4	MEASUREMENT RESULT .....	26
<b>11</b>	<b>FIELD STRENGTH OF SPURIOUS RADIATION MEASUREMENT</b> .....	<b>38</b>
11.1	STANDARD APPLICABLE .....	38
11.2	EUT SETUP (BLOCK DIAGRAM OF CONFIGURATION) .....	38

---

11.3	MEASUREMENT PROCEDURE .....	39
11.4	TEST RESULT .....	40
<b>12</b>	<b>FREQUENCY STABILITY V.S. TEMPERATURE MEASUREMENT .....</b>	<b>46</b>
12.1	STANDARD APPLICABLE .....	46
12.2	TEST SETUP .....	46
12.3	TEST PROCEDURE .....	46
12.4	TEST RESULT .....	47
<b>13</b>	<b>FREQUENCY STABILITY V.S. VOLTAGE MEASUREMENT .....</b>	<b>48</b>
13.1	STANDARD APPLICABLE .....	48
13.2	TEST SETUP .....	48
13.3	TEST PROCEDURE .....	48
13.4	TEST RESULT .....	49
<b>14</b>	<b>AC POWER LINE CONDUCTED EMISSION TEST .....</b>	<b>50</b>
14.1	STANDARD APPLICABLE .....	50
14.2	TEST SETUP .....	50
14.3	TEST PROCEDURE .....	50
14.4	MEASUREMENT RESULT .....	50

### 3 Test Summary

Test Item	Section in CFR 47	Result
RF Exposure (SAR)	§1.1307, §2.1093	Passed* (Please refer to SAR Report)
RF Output Power	§2.1046; § 22.913 (a) § 24.232 (c)	Passed
Modulation Characteristics	§ 2.1047	Passed
99% & -26 dB Occupied Bandwidth	§ 2.1049 § 22.905 § 22.917 § 24.238	Passed
Spurious Emissions at Antenna Terminal	§ 2.1051, § 22.917 (a) § 24.238 (a)	Passed
Field Strength of Spurious Radiation	§ 2.1053 § 22.917 (a) § 24.238 (a)	Passed
Out of band emission, Band Edge	§ 22.917 (a) § 24.238 (a)	Passed
Frequency stability vs. temperature Frequency stability vs. voltage	§ 2.1055 § 22.355 § 24.235	Passed

## 4 General Information

### 4.1 Client Information

Applicant:	Verykool USA Inc.
Address of Applicant:	4350 Executive Drive. Suite 100, San Diego, CA 92121, USA
Manufacturer/Factory:	SHENZHEN KONKA TELECOMMUNICATION TECHNOLOGY CO., LTD.
Address of Manufacturer/Factory:	No.9008 Shennan Road, Overseas Chinese Town, ShenZhen, Guangdong, China

### 4.2 General Description of E.U.T.

Product Name:	GSM Dual Band GPRS Digital Mobile Phone
Model No.:	i600
Data cable(USB):	Length 1m
Earphone line:	Length 1.5m
Power supply:	Lithium Battery DC 3.7V 1100mAh
AC adapter:	Mode: 788 Input AC 100-240V 50/60Hz Output DC 5.0V 1000mA

Cellular Phone Standards Frequency Range and Power	GSM/GPRS 850	824MHz-849MHz	33dBm
	PCS1900	1850MHz-1910MHz	30dBm
Type of Emission:			
IMEI:	354072046000023		
Software Version:	KAAW210_SAE_SP_EN_FR_0.92.713		
Hardware Version:	V1.1		

### 4.3 Related Submittal(s) / Grant (s)

This submittal(s) (test report) is intended for FCC ID: PJO9002 filing to comply with Section Part 22 subpart H and Part 24 subpart E of the FCC CFR 47 Rules.

### 4.4 Test Methodology

Both conducted and radiated testing were performed according to the procedures document on chapter 13 of ANSI C63.4 (2003) and FCC CFR 47.1046, 2.1047, 2.1049, 2.1051, 2.1053, 2.1055 and 2.1057

#### 4.5 Test Facility

The test facility is recognized, certified, or accredited by the following organizations:

- **FCC —Registration No.: 600491**

Global United Technology Service Co., Ltd., Shenzhen EMC Laboratory has been registered and fully described in a report filed with the (FCC) Federal Communications Commission. The acceptance letter from the FCC is maintained in out files. Registration 600491, July 20, 2010.

#### 4.6 Test Location

All tests were performed at:

Global United Technology Service Co., Ltd.

Address: 2nd Floor, Block No.2, Laodong Industrial Zone, Xixiang Road Baoan District, Shenzhen, China

Tel: 0755-27798480

Fax: 0755-27798960

#### 4.7 Test Instruments list

Radiated Emission						
Item	Test Equipment	Manufacturer	Model No.	Inventory No.	Cal.Date (dd-mm-yy)	Cal.Due date (dd-mm-yy)
1	3m Semi-Anechoic Chamber	ZhongYu Electron	9.2(L)*6.2(W)* 6.4(H)	GTS201	Mar. 30 2010	Mar. 30 2011
2	Control Room	ZhongYu Electron	6.2(L)*2.5(W)* 2.4(H)	GTS202	N/A	N/A
3	EMI Test Receiver	Rohde & Schwarz	ESU26	GTS203	Sep. 10 2009	Sep. 10 2010
4	BiConiLog Antenna	SCHWARZBECK MESS-ELEKTRONIK	VULB9163	GTS204	Feb 26 2009	Sep. 10 2010
5	Double -ridged waveguide horn	SCHWARZBECK MESS-ELEKTRONIK	9120D-829	GTS205	June 30 2010	June 30 2011
6	EMI Test Software	AUDIX	E3	N/A	N/A	N/A
7	Coaxial Cable	GTS	N/A	GTS400	Apr. 01 2010	Apr. 01 2011
8	Coaxial Cable	GTS	N/A	GTS401	Apr. 01 2010	Apr. 01 2011
9	Coaxial cable	GTS	N/A	GTS402	Apr. 01 2010	Apr. 01 2011
10	Coaxial Cable	GTS	N/A	GTS407	Apr. 01 2010	Apr. 01 2011
11	Coaxial Cable	GTS	N/A	GTS408	Apr. 01 2010	Apr. 01 2011
12	Amplifier(10KHz-5GHz)	Sonnoma Instrument	305-1052	GTS210	Apr. 01 2010	Apr. 01 2011
13	Amplifier(2GHz-20GHz)	HP	8349B	GTS231	Apr. 01 2010	Apr. 01 2011
14	Universal radio communication tester	Rohde & Schwarz	CMU200	GTS235	May 11 2010	May 11 2011
15	Signal Generator	Rohde & Schwarz	SML03	GTS236	May 11 2010	May 11 2011
16	Temp. Humidity/Barometer	Oregon Scientific	BA-888	GTS248	May 11 2010	May 11 2011
17	D.C. Power Supply	Instek	PS-3030	GTS232	NA	NA
18	Splitter	Agilent	11636B	GTS237	May 11 2010	May 11 2011

## 5 SYSTEM TEST CONFIGURATION

### 5.1 EUT Configuration:

The EUT configuration for testing is installed on RF field strength measurement to meet the Commissions requirement and operating in a manner which intends to maximize its emission characteristics in a continuous normal application.

### 5.2 EUT Exercise

The EUT (Transmitter) was operated in the engineering mode to fix the Tx frequency which was for the purpose of the measurements.

### 5.3 Test Procedure

#### 5.3.1 Conducted Emissions

The EUT is placed on a turn table which is 0.8m above ground plane. According to the requirements in Section 7 and 13 of ANSI C63.4-2003. Conducted emissions from the EUT measured in the frequency range between 0.15MHz and 30MHz using CISPR Quasi-Peak and Average detector mode.

#### 5.3.2 Radiated Emissions

The EUT is placed on a turn table which is 1.0m above ground plane. The turn table shall rotate 360 degrees to determine the position of maximum emission level. EUT is set 3m away from the receiving antenna which varied from 1m to 4m to find out the highest emission. And also, each emission was to be maximized by changing the polarization of receiving antenna both horizontal and vertical. In order to find out the max. emission, the relative positions of this hand-held transmitter (EUT) was rotated through three orthogonal axes according to the requirements in Section 8 and 13 of ANSI C63.4-2003.

### 5.4 Configuration of Tested System

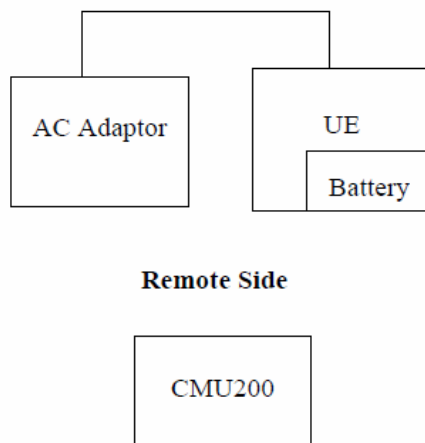



## 5.5 DESCRIPTION OF TEST MODES

The EUT has been tested under operating condition.

EUT staying in continuous transmitting mode. Channel Low, Mid and High for each type band with rated data rate were chosen for full testing.

The field strength of spurious radiation emission was measured as EUT stand-up position (H mode) and lie down position (E1, E2 mode) for both GSM/PCS with power adaptors, earphone and Data cable. The worst-case H mode for GSM 850 band, PCS1900 band.

## 6 RF POWER OUTPUT MEASUREMENT

### 6.1 Standard Applicable

According to FCC §2.1046.

FCC 22.913(a) Mobile station are limited to 7W

FCC 24.232(b) Mobile station are limited to 2W.

### 6.2 Test setup

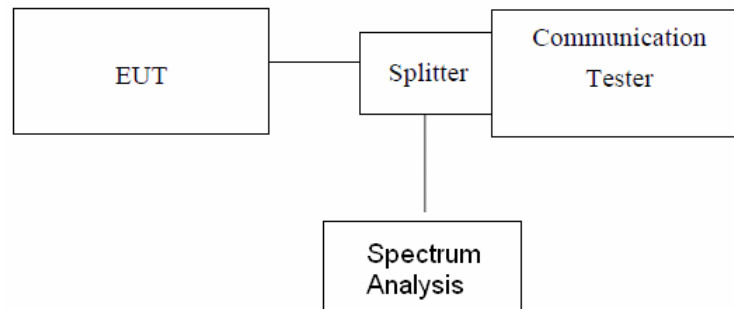

*Note: Measurement setup for testing on Antenna connector*

### 6.3 Measurement Procedure

The transmitter output was connected to a calibrated attenuator, the other end of which was connected to a spectrum analysis. Transmitter output was read off the spectrum analysis in dBm. The power output at the transmitter antenna port was determined by adding the value of the attenuator to spectrum analysis reading.

### 6.4 Test Result

EUT Mode	Frequency (MHz)	CH	Power meter Reading (dBm)	Path Loss (dB)	Peak Power(dBm)
GSM 850	824.20	128	31.58	0.50	32.08
	836.60	190	31.57	0.50	32.07
	848.80	251	31.70	0.50	32.20

EUT Mode	Frequency (MHz)	CH	Power meter Reading (dBm)	Path Loss (dB)	Peak Power(dBm)
PCS 1900	1850.20	512	28.09	0.50	28.59
	1880.00	661	28.31	0.50	28.81
	1909.80	810	28.16	0.50	28.66

Please refer to the following plots.

Test mode:	GSM850	Test channel:	128
------------	--------	---------------	-----

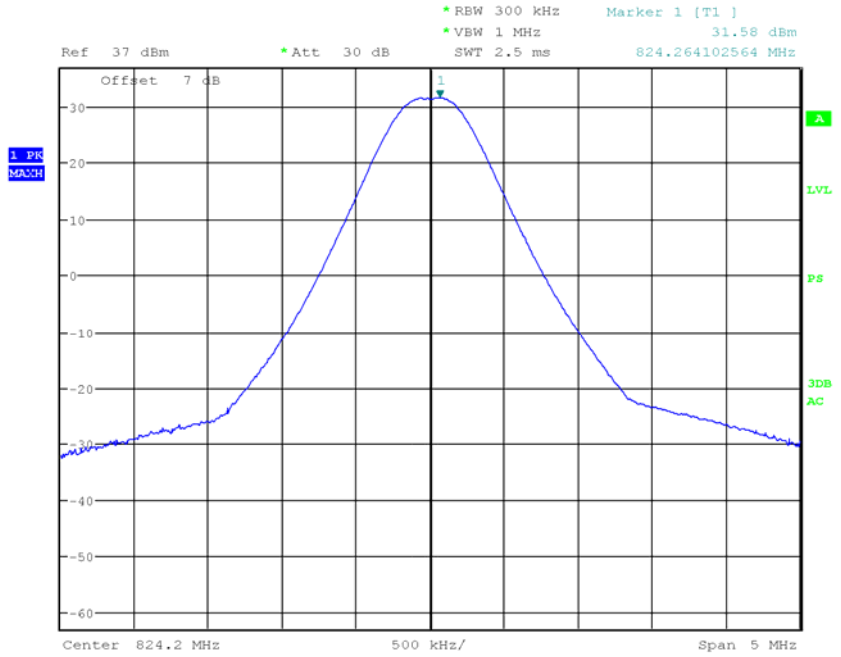

Test mode:	GSM850	Test channel:	190
------------	--------	---------------	-----

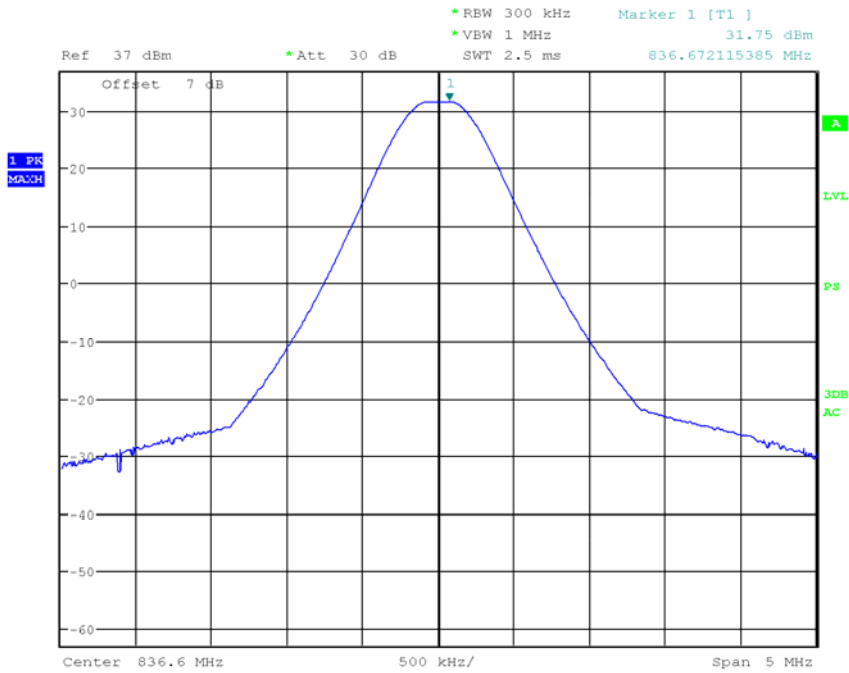

Test mode:	GSM850	Test channel:	251
------------	--------	---------------	-----

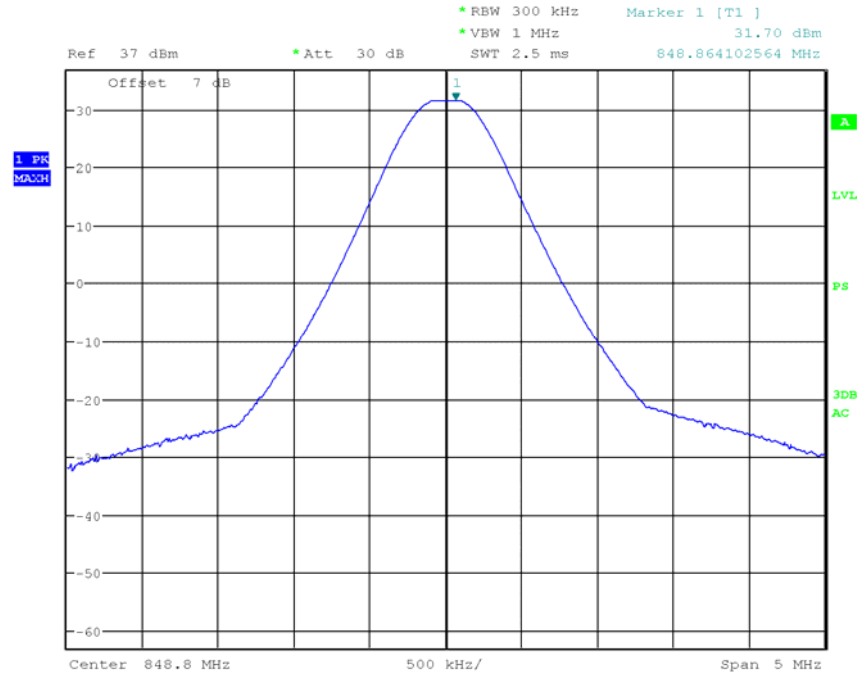

Test mode:	PCS1900	Test channel:	512
------------	---------	---------------	-----

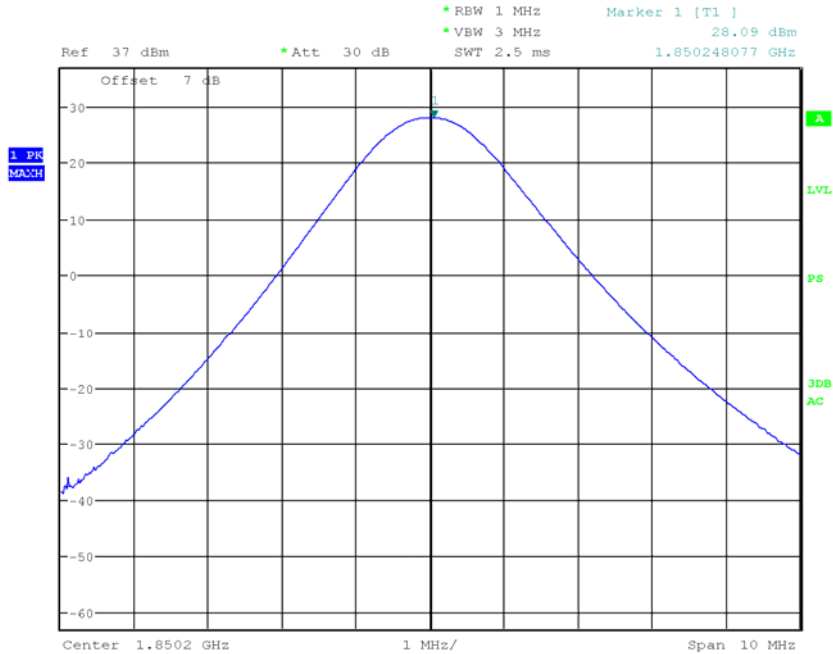

Test mode:	PCS1900	Test channel:	661
------------	---------	---------------	-----

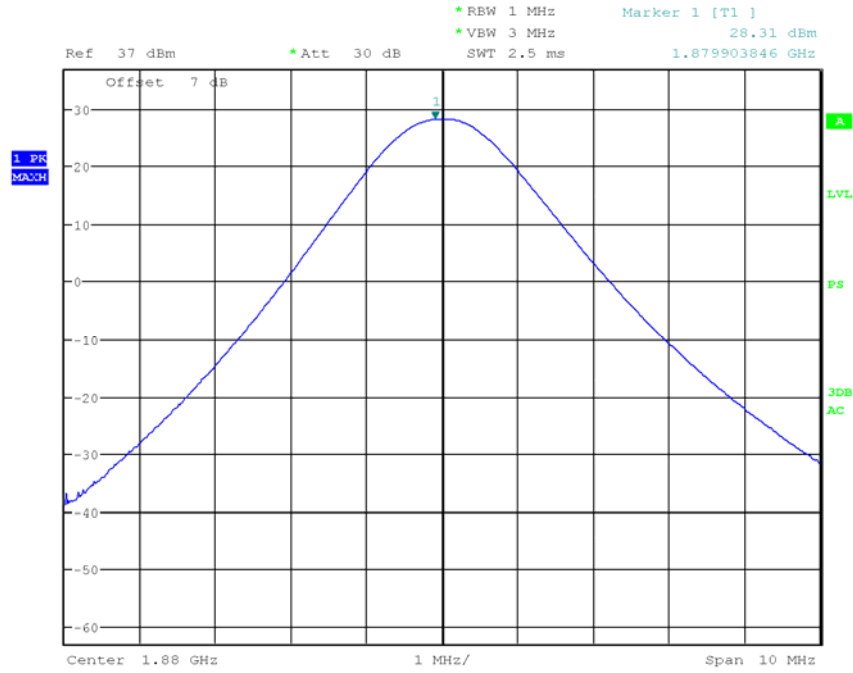

Test mode:	PCS1900	Test channel:	810
------------	---------	---------------	-----

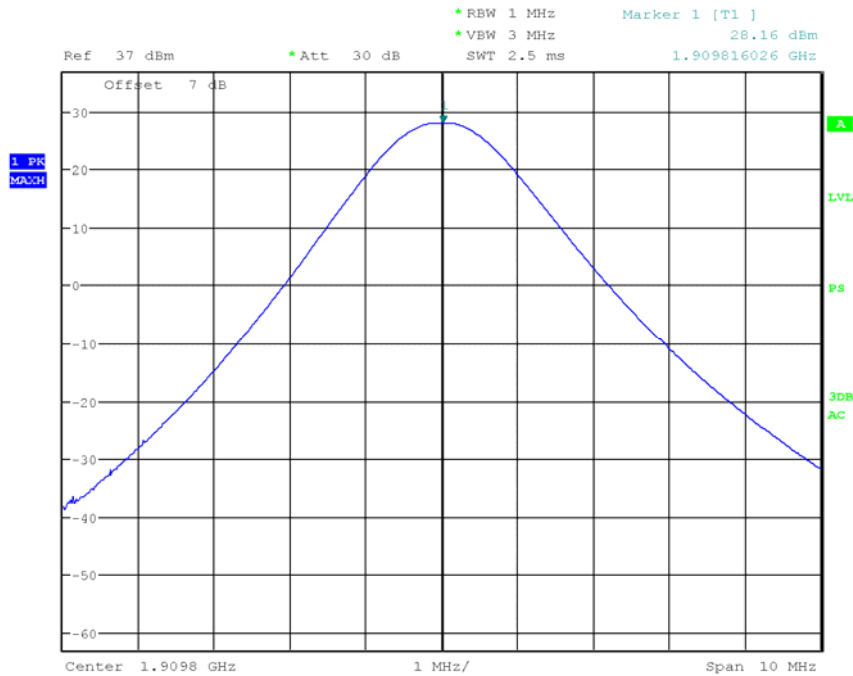

## 7 ERP, EIRP MEASUREMENT

### 7.1 Standard Applicable

According to FCC §2.1046

FCC 22.913(a) Mobile station are limited to 7W ERP.

FCC 24.232(b) Mobile station are limited to 2W EIRP.

### 7.2 Test SET-UP (Block Diagram of Configuration)

(A) Radiated Emission Test Set-Up, Frequency Below 1000MHz

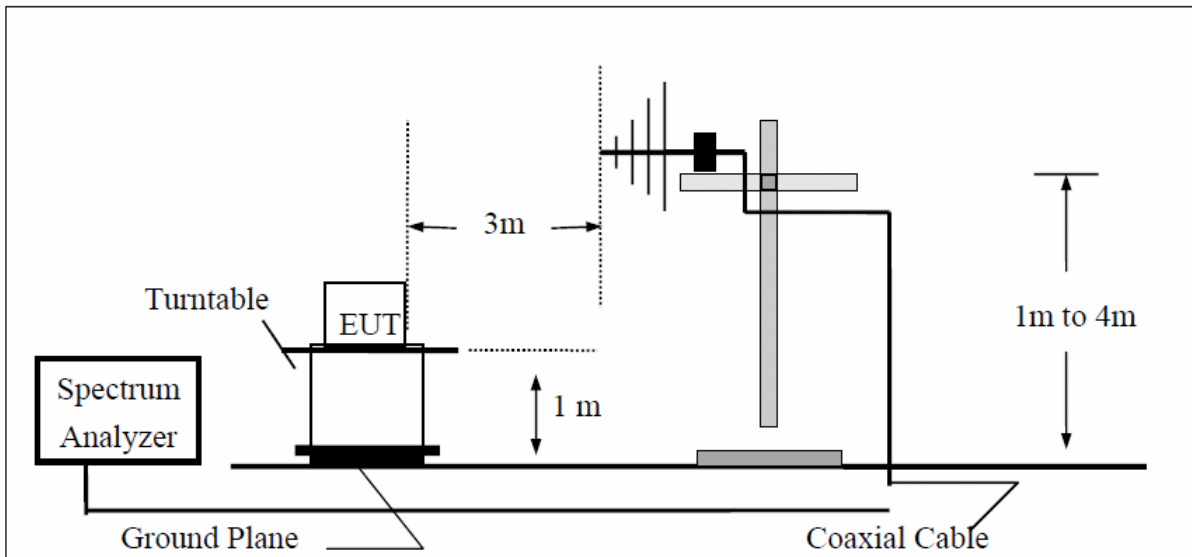

(B) Radiated Emission Test Set-UP Frequency Over 1 GHz

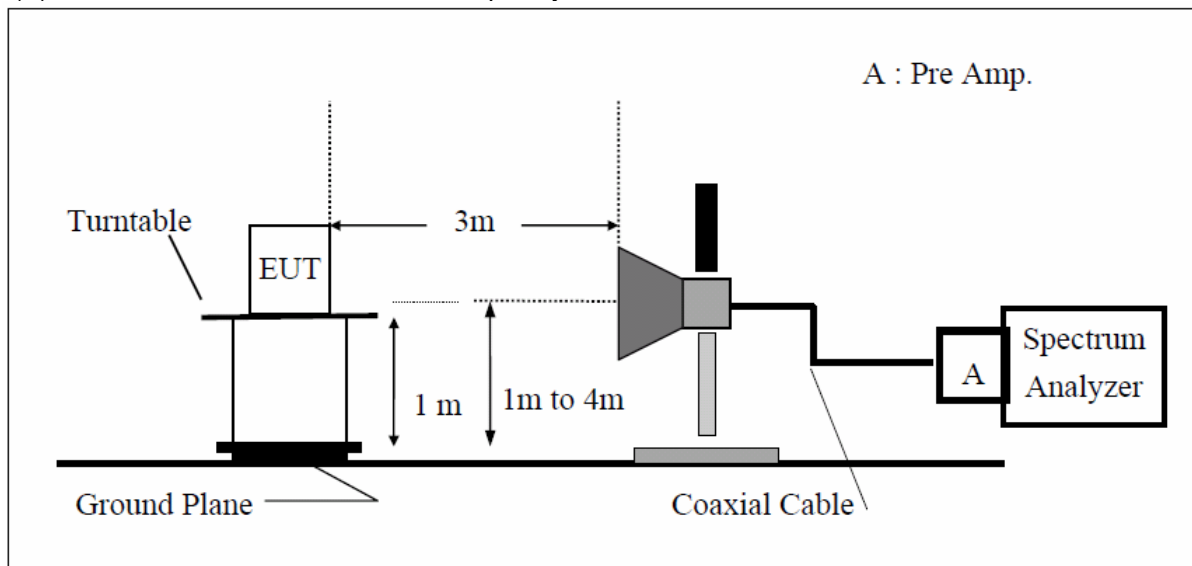

(C) Substituted Method Test Set-UP

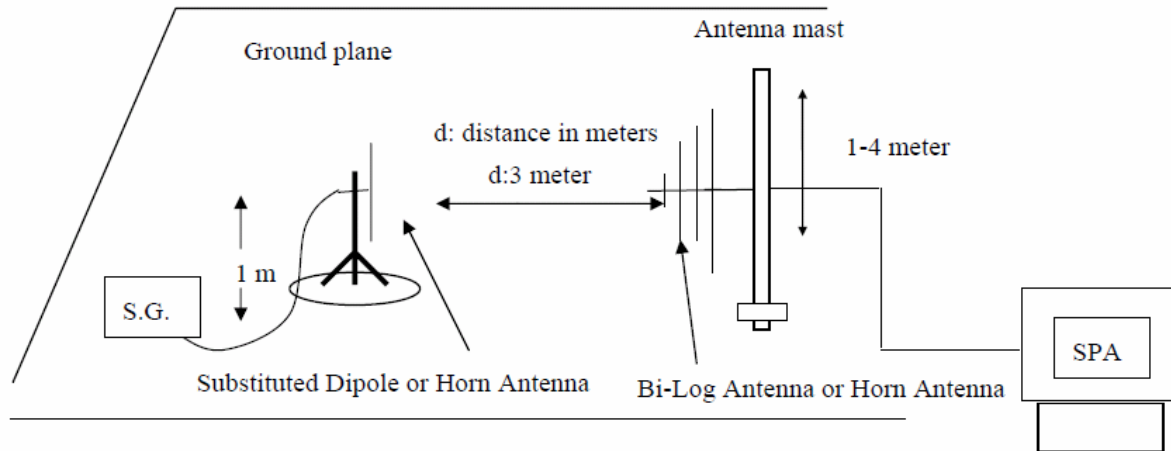

### 7.3 Measurement Procedure

The EUT was placed on an non-conductive turntable using a non-conductive support. The radiated emission at the fundamental frequency was measured at 3 m with a test antenna and EMI spectrum analyzer.

During the measurement, the EUT was communication with the station. The highest emission was recorded with the rotation of the turntable and the lowering of the test antenna from 4m to 1m. The reading was recorded and the field strength (E in dBuV/m) was calculated.

ERP in frequency band 824.2 –848.80.8MHz were measured using a substitution method. The EUT was replaced by dipole antenna connected, the S.G. output was recorded and ERP was calculated as follows:

EIRP in frequency band 1850.2 –1909.8MHz were measured using a substitution method. The EUT was replaced by or horn antenna connected, the S.G. output was recorded and EIRP was calculated as follows:

$$\text{ERP} = \text{S.G. output (dBm)} + \text{Antenna Gain (dBd)} - \text{Cable Loss (dB)}$$

$$\text{EIRP} = \text{S.G. output (dBm)} + \text{Antenna Gain (dBi)} - \text{Cable Loss (dB)}$$

### 7.4 Measurement Result

EUT mode	Frequency (MHz)	CH	EUT Pol.	Antenna Pol.	SPA Reading (dBUV)	S.G. Output (dBm)	Antenna Gain (dBd)	Cable Loss (dB)	ERP (dBm)	Limit (dBm)
GSM 850	824.20	128	H	V	118.13	31.74	-7.87	3.62	20.24	38.45
				H	124.78	38.51	-7.87	3.62	27.01	38.45
			E1	V	120.76	34.37	-7.87	3.62	22.87	38.45
				H	114.06	27.79	-7.87	3.62	16.29	38.45
			E2	V	115.69	29.30	-7.87	3.62	17.80	38.45
				H	123.14	36.87	-7.87	3.62	25.37	38.45
	836.60	190	H	V	118.99	32.74	-7.88	3.65	21.21	38.45
				H	126.37	40.14	-7.88	3.65	28.61	38.45
			E1	V	122.01	35.76	-7.88	3.65	24.23	38.45
				H	115.00	28.77	-7.88	3.65	17.24	38.45
			E2	V	116.47	30.22	-7.88	3.65	18.69	38.45
				H	124.90	38.67	-7.88	3.65	27.14	38.45
	848.80	251	H	V	120.66	34.54	-7.88	3.68	22.98	38.45
				H	128.10	41.91	-7.88	3.68	30.35	38.45
			E1	V	124.13	38.01	-7.88	3.68	26.45	38.45
				H	115.99	29.80	-7.88	3.68	18.24	38.45
			E2	V	117.76	31.64	-7.88	3.68	20.08	38.45
				H	126.93	40.74	-7.88	3.68	29.18	38.45

**Remark :**

- (1) The RBW,VBW of SPA for frequency  
 Below 1GHz was RBW=100 KHz, VBW=300KHz,  
 Above 1GHz was RBW= 1MHz , VBW= 3MHz



EUT mode	Frequency (MHz)	CH	EUT Pol.	Antenna Pol.	SPA Reading (dBUV)	S.G. Output (dBm)	Antenna Gain (dBd)	Cable Loss (dB)	ERP (dBm)	Limit (dBm)
PCS 1900	1850.20	512	H	V	123.40	19.01	9.90	5.56	23.35	33.00
				H	130.44	26.26	9.90	5.56	30.60	33.00
			E1	V	127.78	23.39	9.90	5.56	27.73	33.00
				H	127.73	23.55	9.90	5.56	27.89	33.00
			E2	V	128.83	24.44	9.90	5.56	28.78	33.00
				H	131.23	27.05	9.90	5.84	31.11	33.00
	1880.00	661	H	V	121.50	17.14	9.99	5.61	21.52	33.00
				H	129.07	24.93	9.99	5.61	29.30	33.00
			E1	V	127.18	22.82	9.99	5.61	27.20	33.00
				H	126.96	22.82	9.99	5.61	27.19	33.00
			E2	V	127.28	22.92	9.99	5.61	27.30	33.00
				H	130.39	26.25	9.99	5.61	30.62	33.00
	1909.80	810	H	V	121.61	17.28	10.08	5.66	21.70	33.00
				H	128.96	24.85	10.08	5.66	29.27	33.00
			E1	V	126.01	21.68	10.08	5.66	26.10	33.00
				H	126.03	21.92	10.08	5.66	26.34	33.00
			E2	V	126.67	22.34	10.08	5.66	26.76	33.00
				H	129.34	25.23	10.08	5.66	29.65	33.00

**Remark :**

- (1) The RBW,VBW of SPA for frequency  
 Below 1GHz was RBW=100 KHz, VBW=300KHz,  
 Above 1GHz was RBW= 1MHz , VBW= 3MHz

## 8 MODULATION CHARACTERISTIC

According to FCC § 2.1047(d), Part 22H & 24E there is no specific requirement for digital modulation, therefore modulation characteristic is not presented.

## 9 OCCUPIED BANDWIDTH

### 9.1 Standard Applicable

CFR 47 §2.1049

### 9.2 Test setup

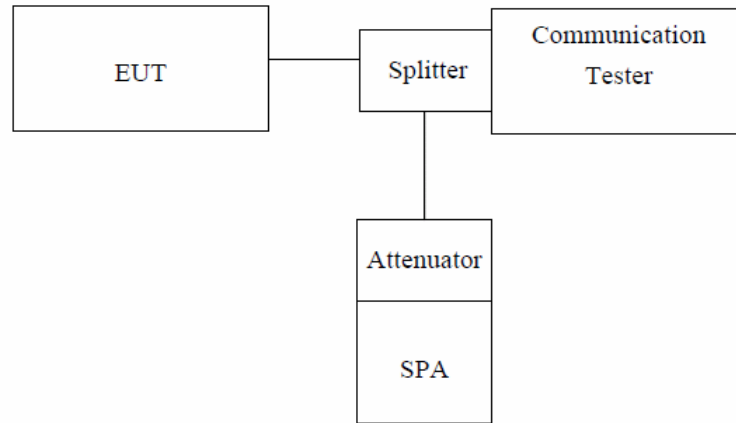

*Note: Measurement setup for testing on Antenna connector*

### 9.3 Test Procedure

The EUT's output RF connector was connected with a short cable to the spectrum analyzer, RBW (10/47KHz) was set to about 1% of emission BW, VBW= 3 times RBW(30/150KHz), -26dBc display line was placed on the screen (or 99% bandwidth), the occupied bandwidth is the delta frequency between the two points where the display line intersects the signal trace.

### 9.4 Test Result

EUT Mode	Frequency(MHz)	CH	26dB bandwidth	99% Bandwidth(MHz)
GSM 850	824.20	128	317.31	248.40
	836.60	190	318.91	248.40
	848.80	251	320.51	246.80

EUT Mode	Frequency(MHz)	CH	26dB bandwidth	99% Bandwidth(MHz)
PCS 1900	1850.20	512	318.91	246.79
	1880.00	661	317.31	246.79
	1909.80	810	320.51	246.79

Please refer to the following plots.

**99% bandwidth:**

Test mode:	GSM850	Test channel:	128
------------	--------	---------------	-----

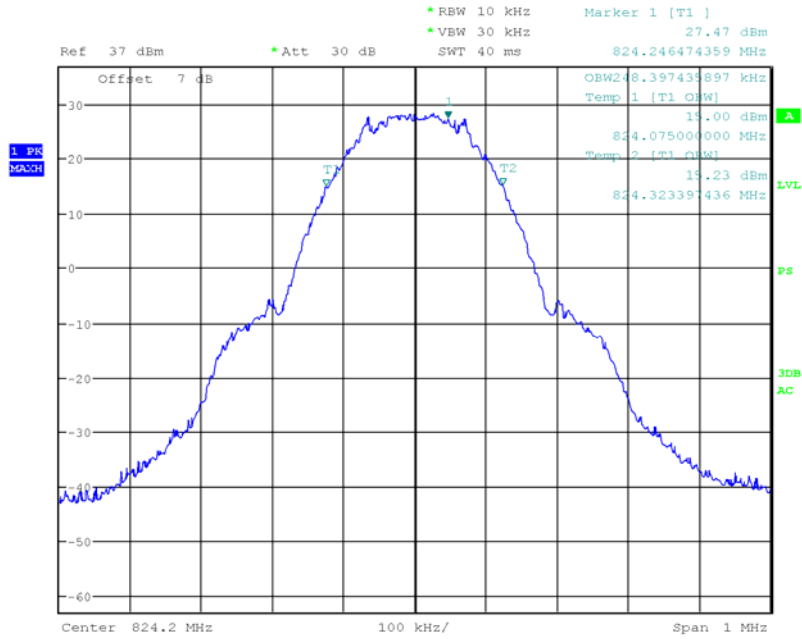

Test mode:	GSM850	Test channel:	190
------------	--------	---------------	-----

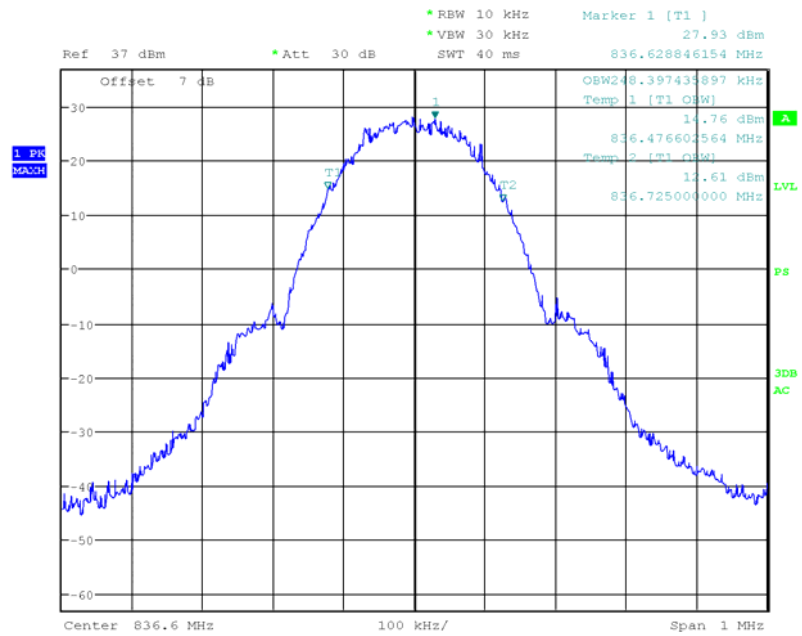

Test mode:	GSM850	Test channel:	251
------------	--------	---------------	-----

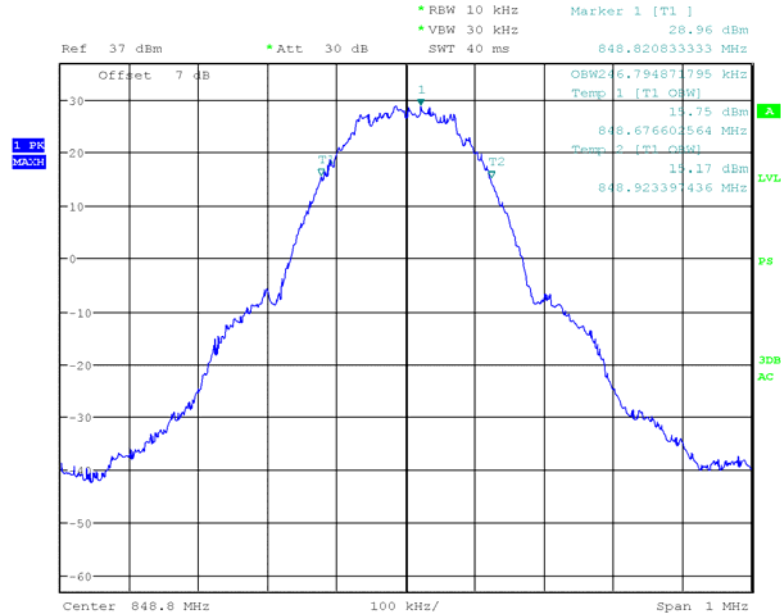

Test mode:	PCS1900	Test channel:	512
------------	---------	---------------	-----

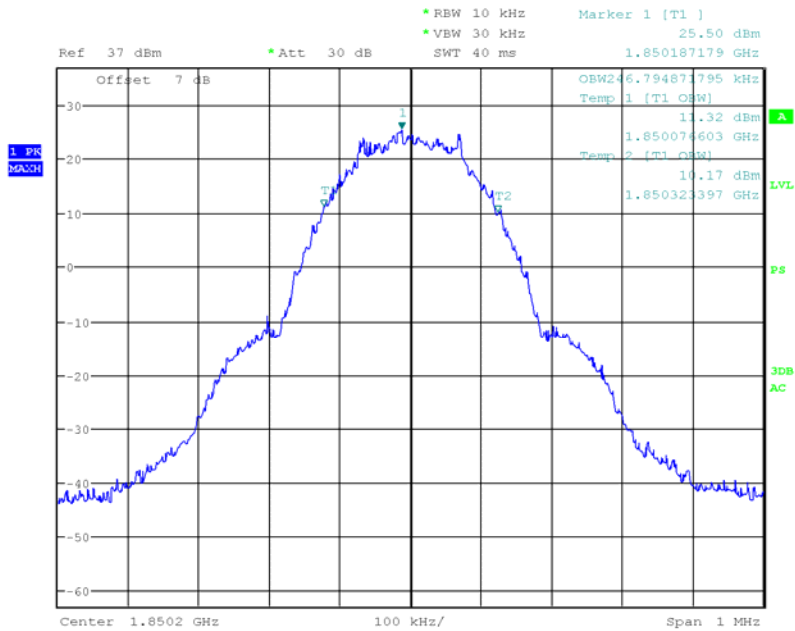

Test mode:	PCS1900	Test channel:	661
------------	---------	---------------	-----

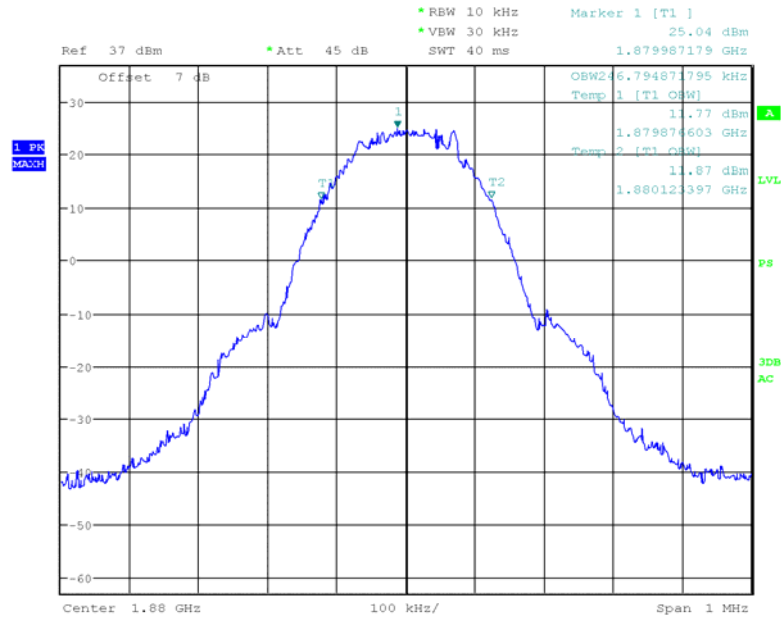

Test mode:	PCS1900	Test channel:	810
------------	---------	---------------	-----

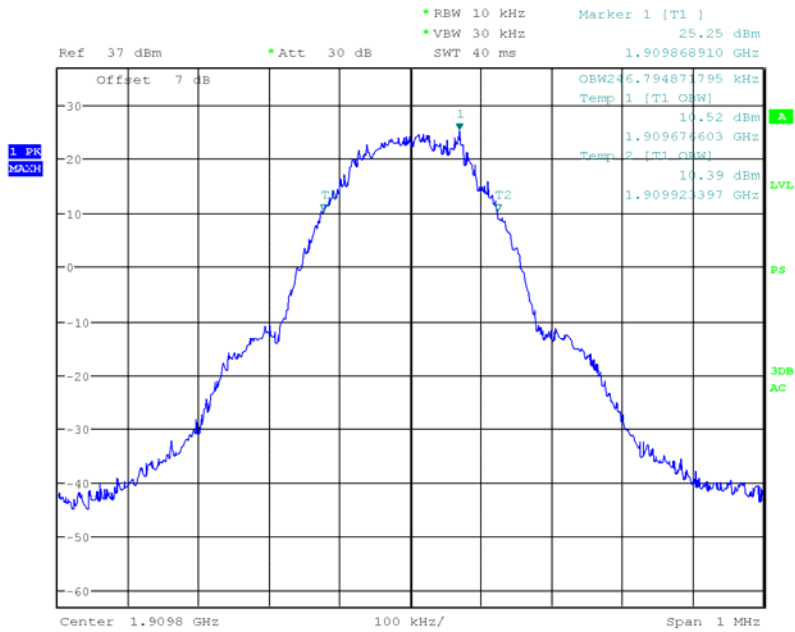

**26dB bandwidth:**

Test mode:	GSM850	Test channel:	128
------------	--------	---------------	-----

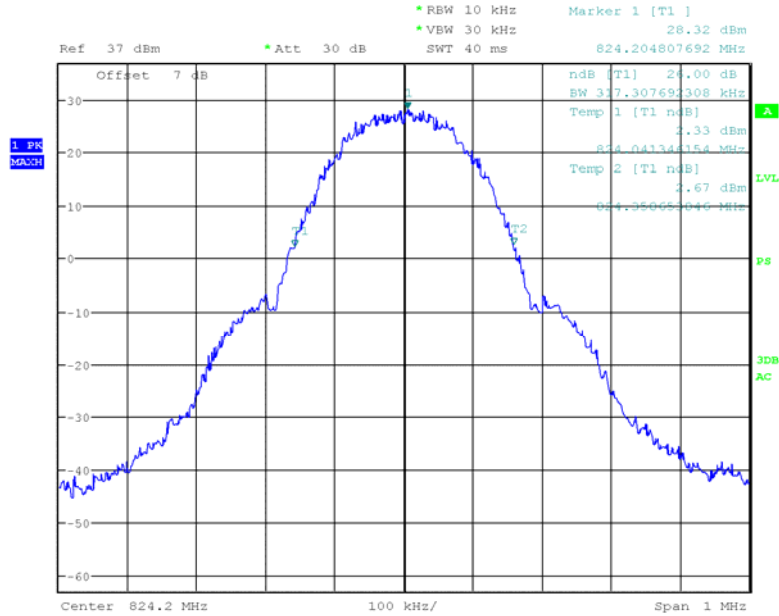

Test mode:	GSM850	Test channel:	190
------------	--------	---------------	-----

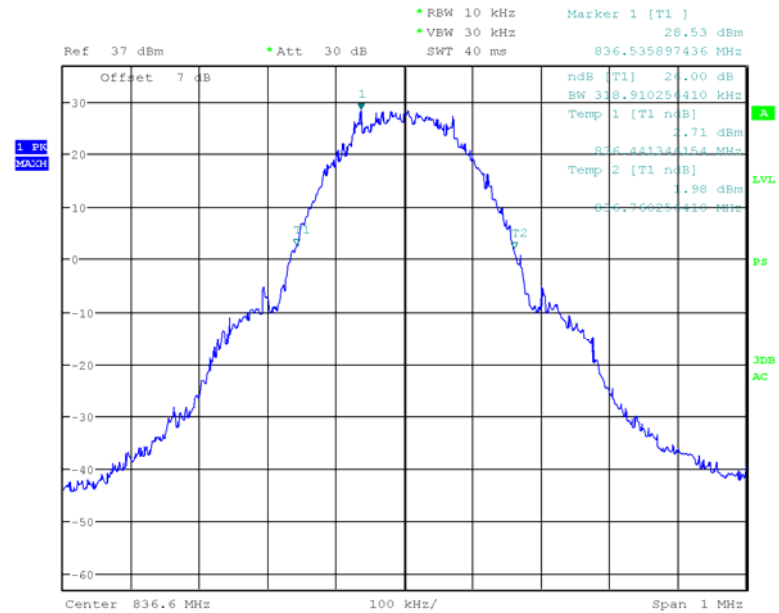

Test mode:	GSM850	Test channel:	251
------------	--------	---------------	-----

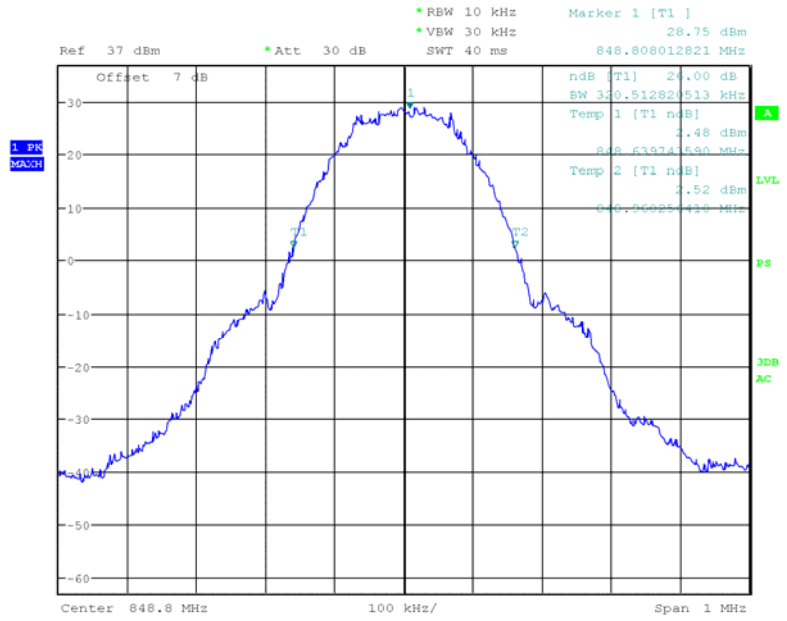

Test mode:	PCS1900	Test channel:	512
------------	---------	---------------	-----

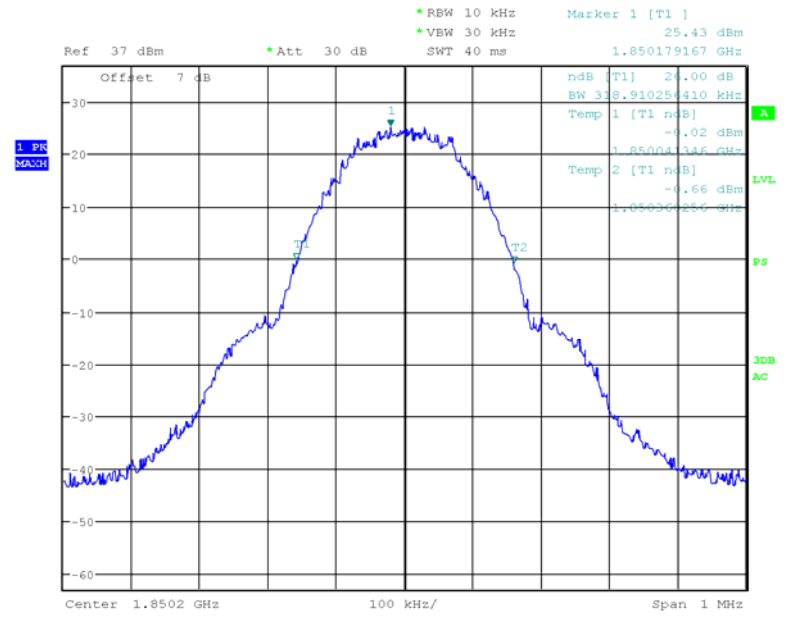



Test mode:	PCS1900	Test channel:	661
------------	---------	---------------	-----

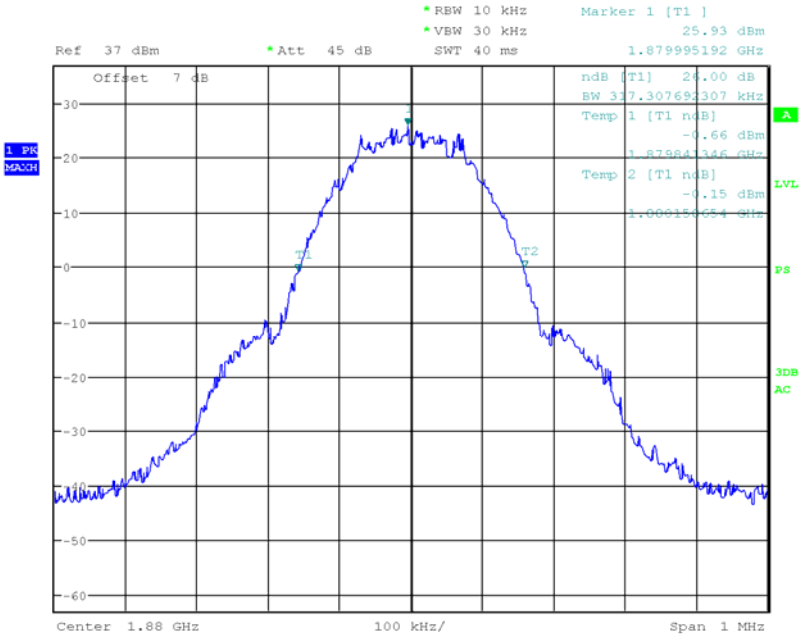

Test mode:	PCS1900	Test channel:	810
------------	---------	---------------	-----

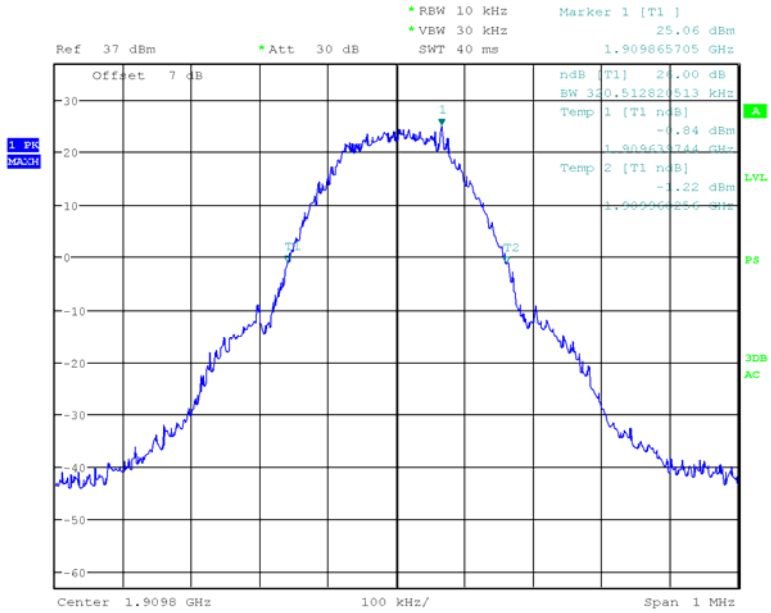

## 10 OUT OF BAND EMISSION AT ANTENNA TERMINALS

### 10.1 Standard Applicable

According to FCC §2.1051.

FCC §22.917(a), §24.238(a), the magnitude of each spurious and harmonic emission that can be detected when the equipment is operated under the conditions specified in the instruction manual and/ or alignment procedure, shall not be less than  $43 + 10 \log$  (mean output power in watts) dBc below the mean power output outside a license's frequency block (-13dBm)

### 10.2 Test setup

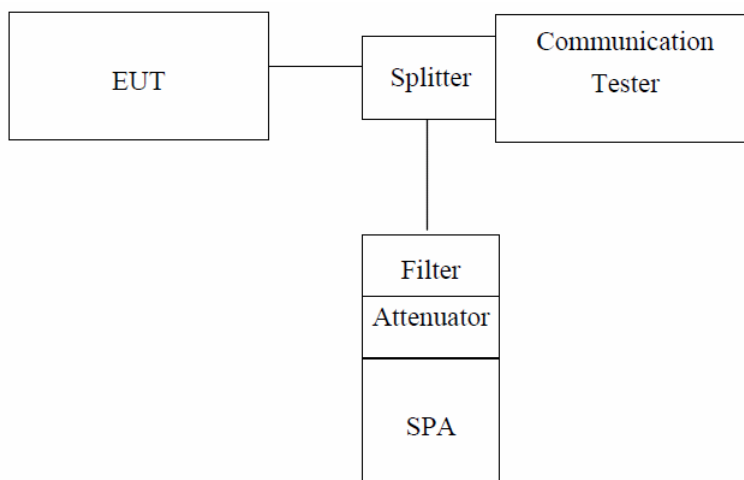

*Note: Measurement setup for testing on Antenna connector*

### 10.3 Measurement Procedure

The RF output of the transceiver was connected to a spectrum analyzer through appropriate attenuation.

The resolution bandwidth of the spectrum analyzer was set at 1MHz, sufficient scans were taken to show the out of band Emissions if any up to 10th harmonic.

For the out of band: Set the RBW, VBW = 1MHz, Start=30MHz, Stop= 10th harmonic.

Limit = -13dBm

Band Edge Requirements: In the 1 MHz bands immediately outside and adjacent to the frequency block, a resolution bandwidth of at least 1 percent of the emission bandwidth of the fundamental emission of the transmitter may be employed to measure the out of band Emissions.

Limit = -13dBm.

### 10.4 Measurement Result

## Test Result

Test mode:	GSM850	Test channel:	128
------------	--------	---------------	-----

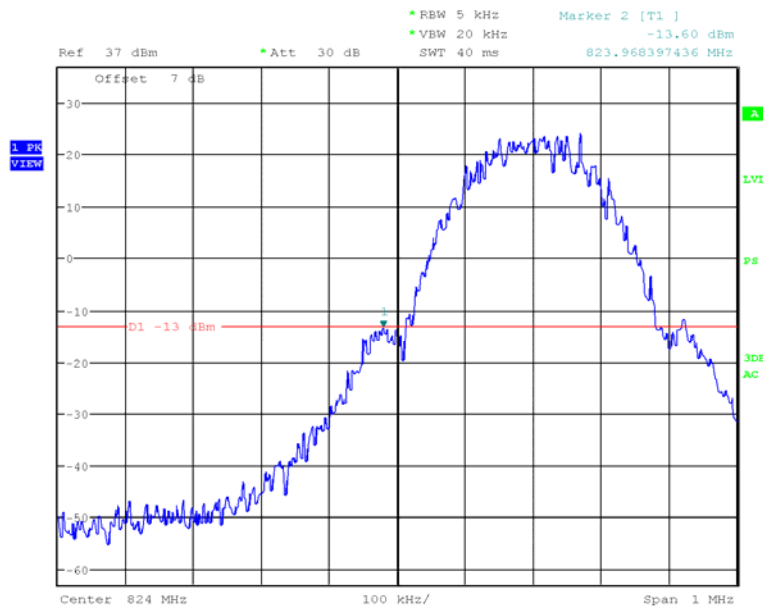
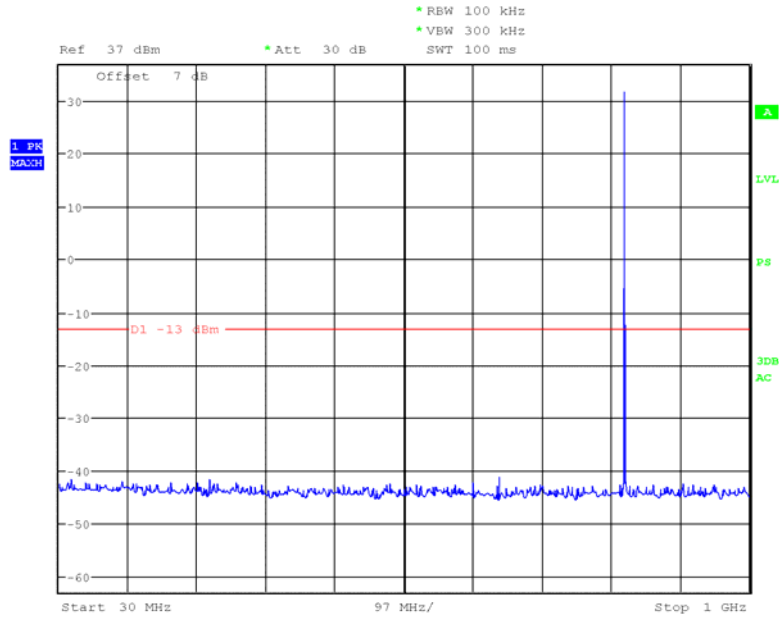



Test mode:	GSM850	Test channel:	190
------------	--------	---------------	-----

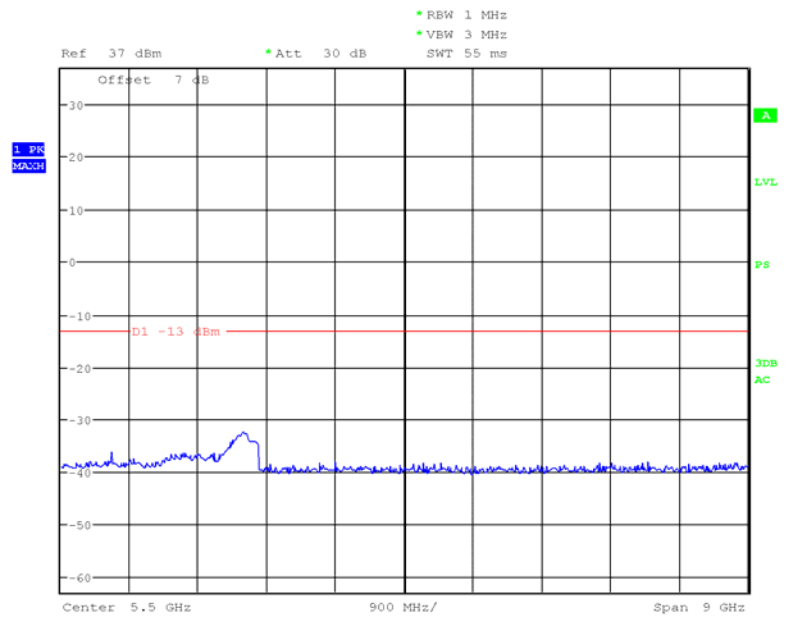
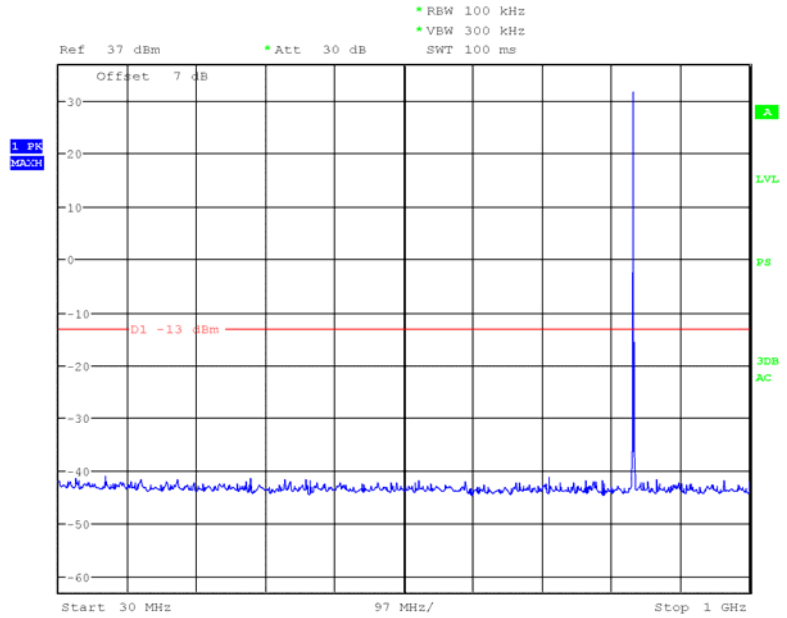

Test mode:	GSM850	Test channel:	251
------------	--------	---------------	-----

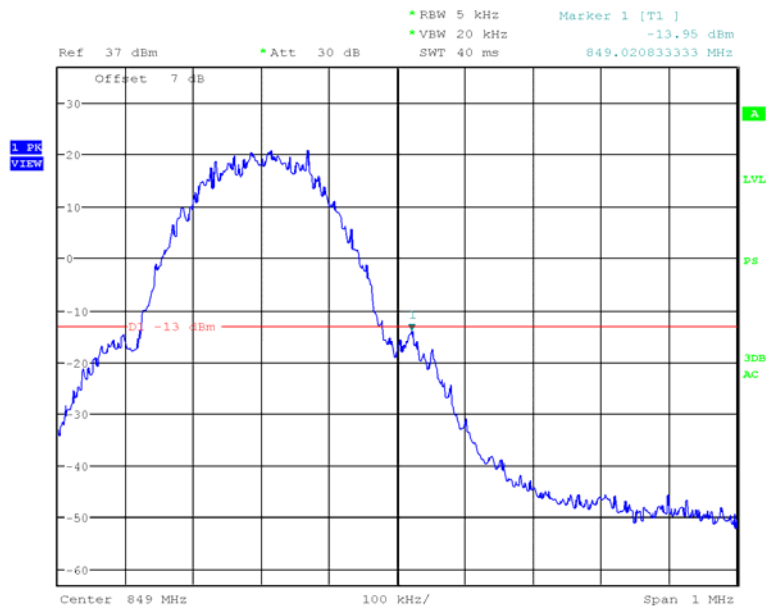
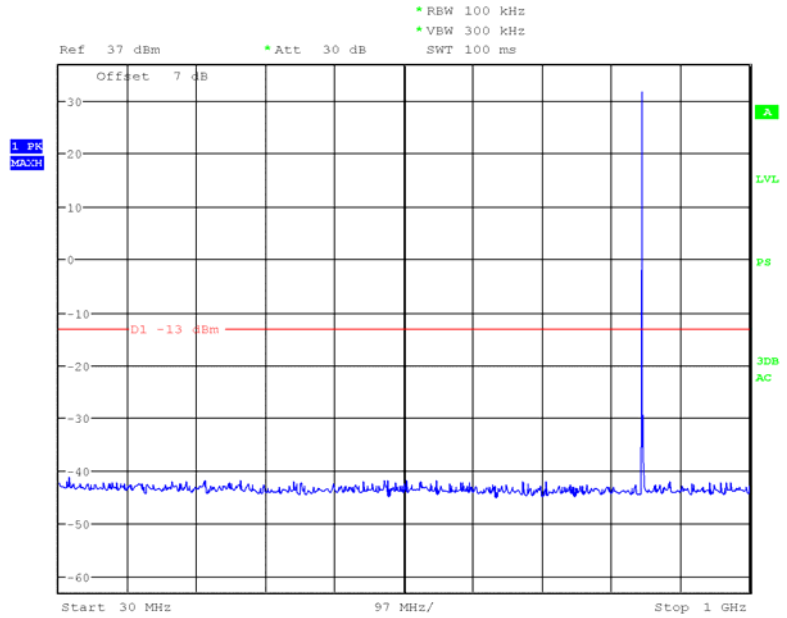



Test mode:	PCS1900	Test channel:	512
------------	---------	---------------	-----

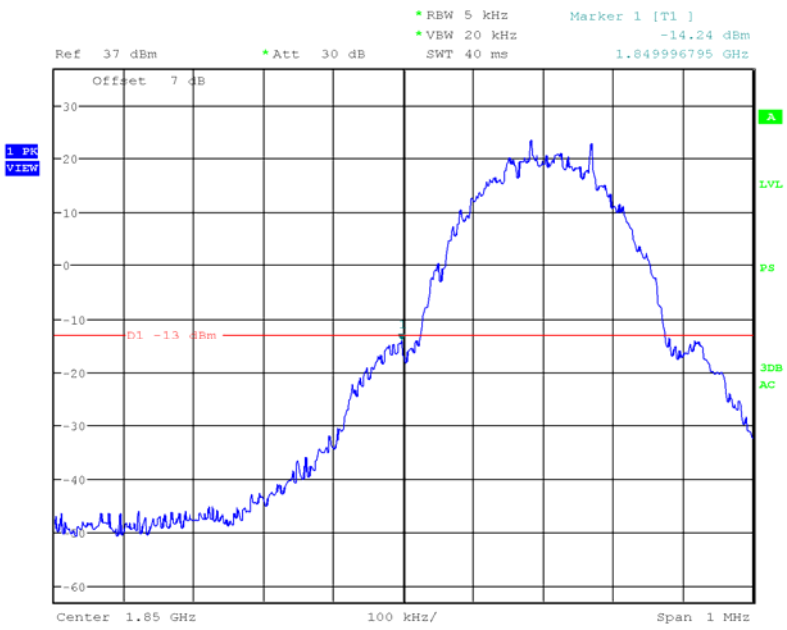
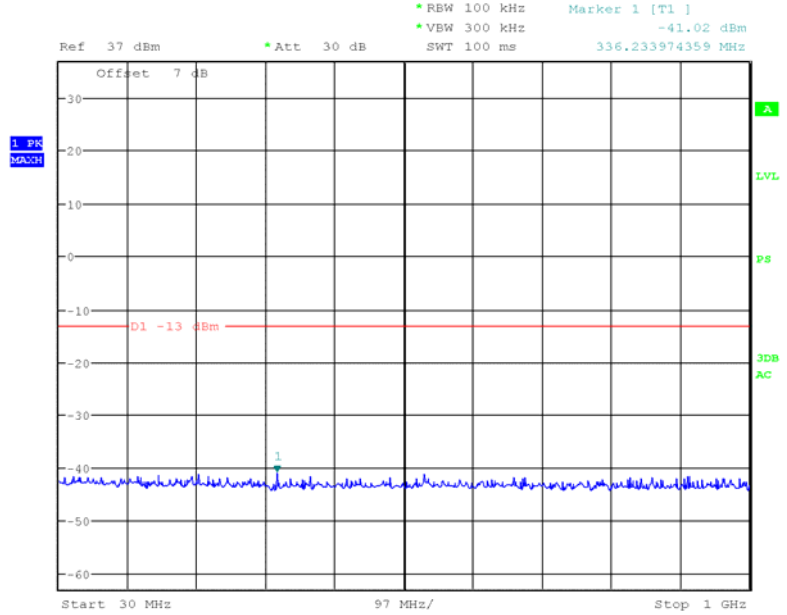



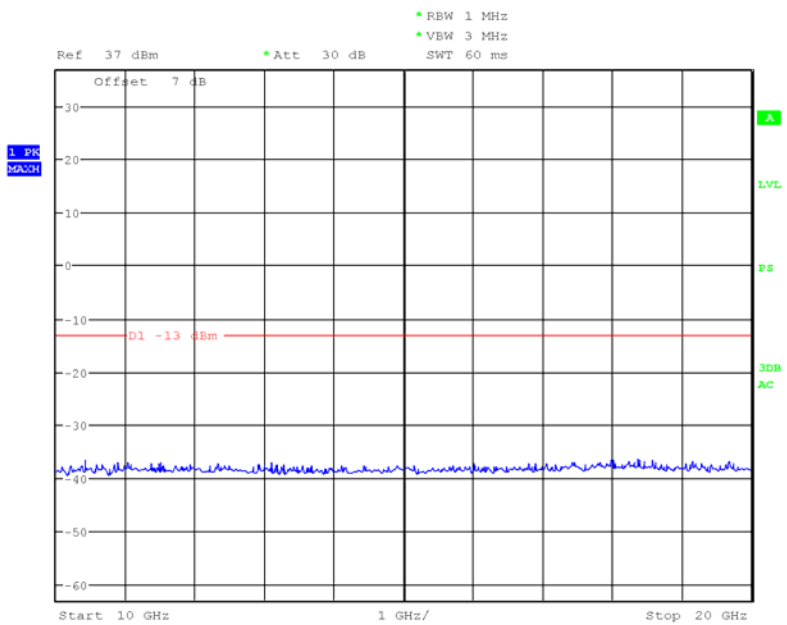
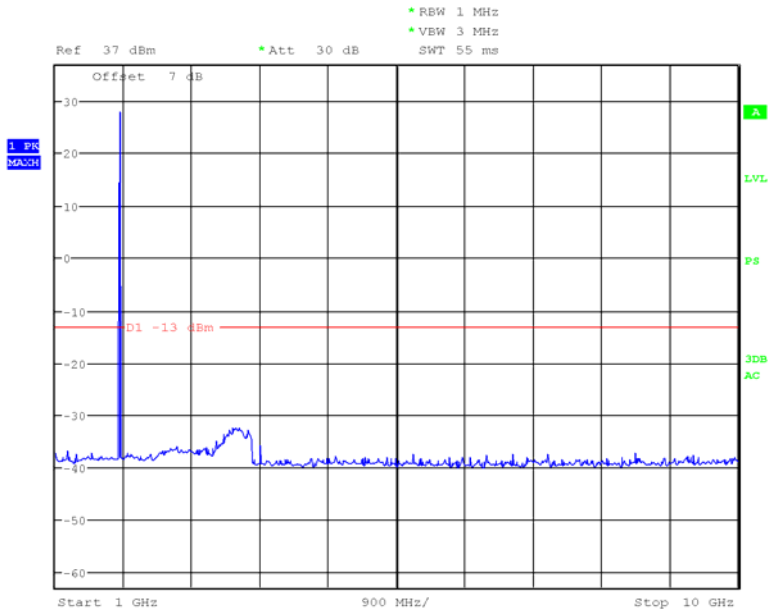

Test mode:	PCS1900	Test channel:	661
------------	---------	---------------	-----

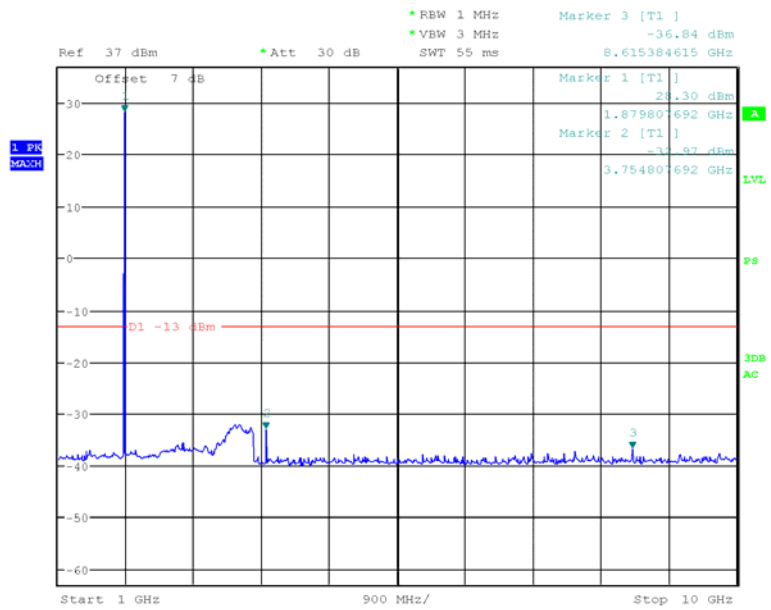
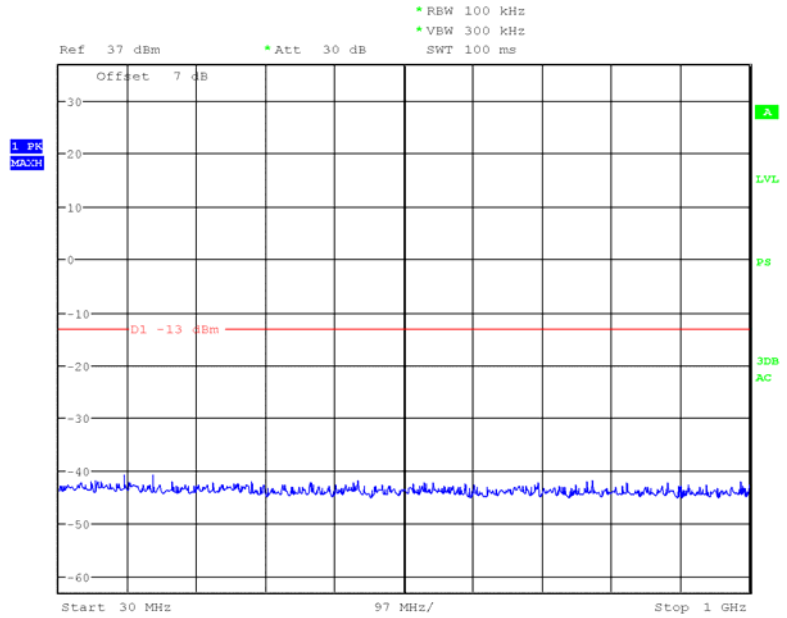

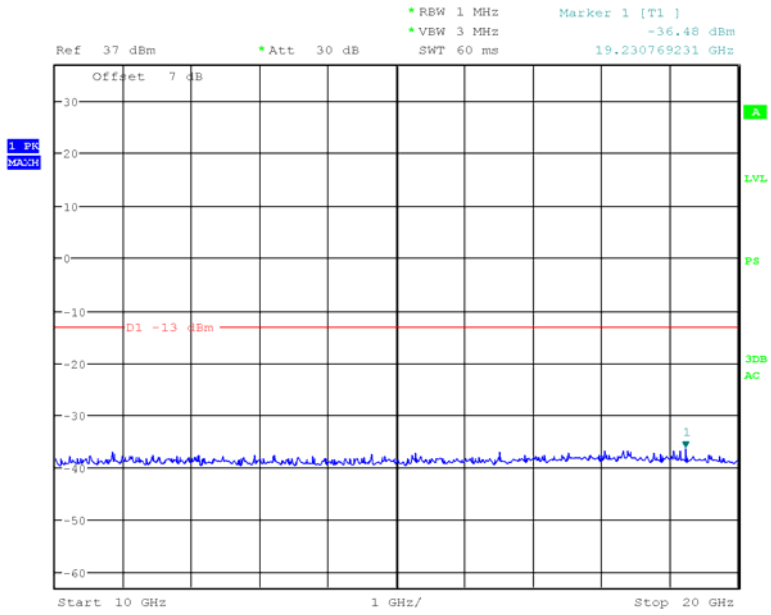

Test mode:	PCS1900	Test channel:	810
------------	---------	---------------	-----

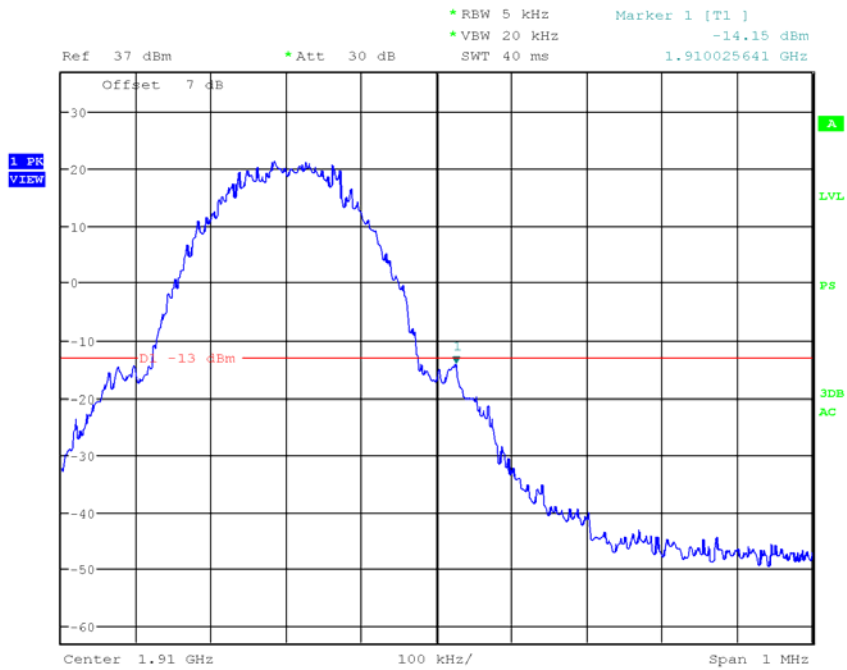
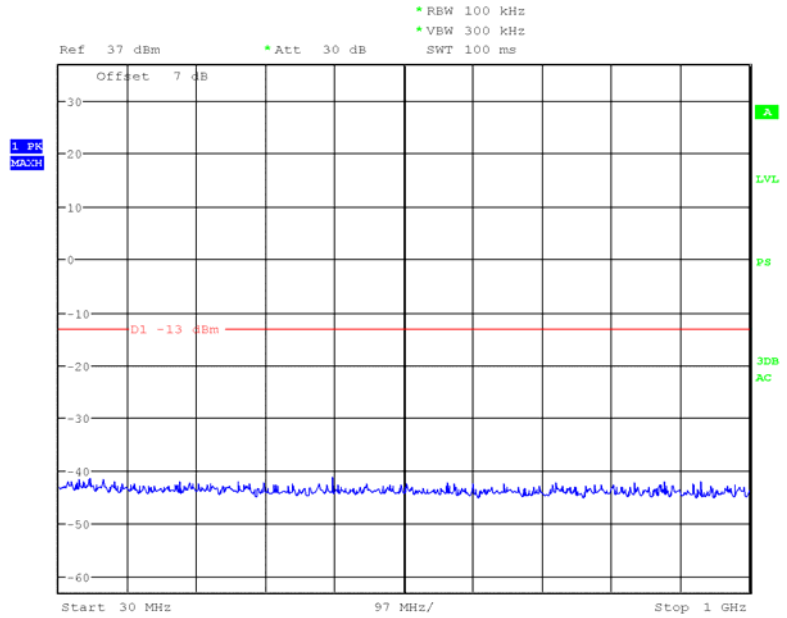

Date: 25.JUL.2010 13:48:47

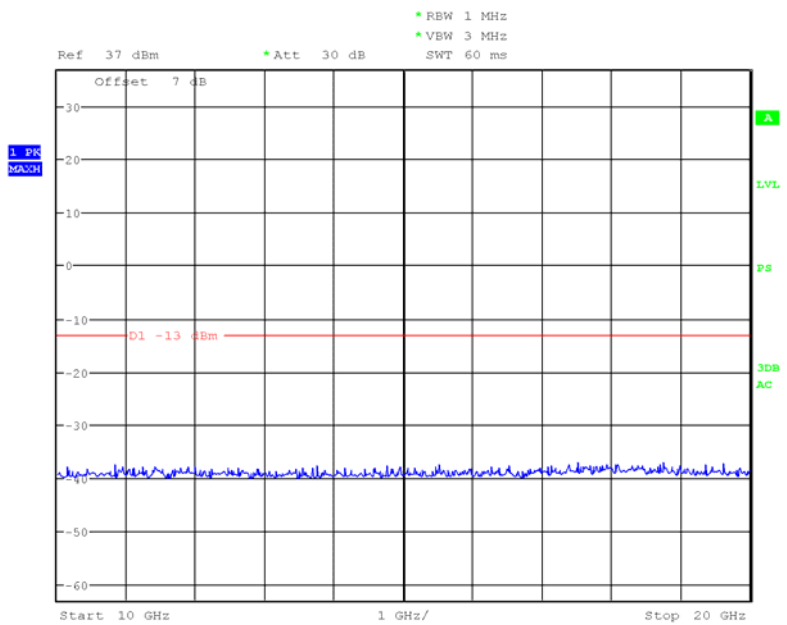
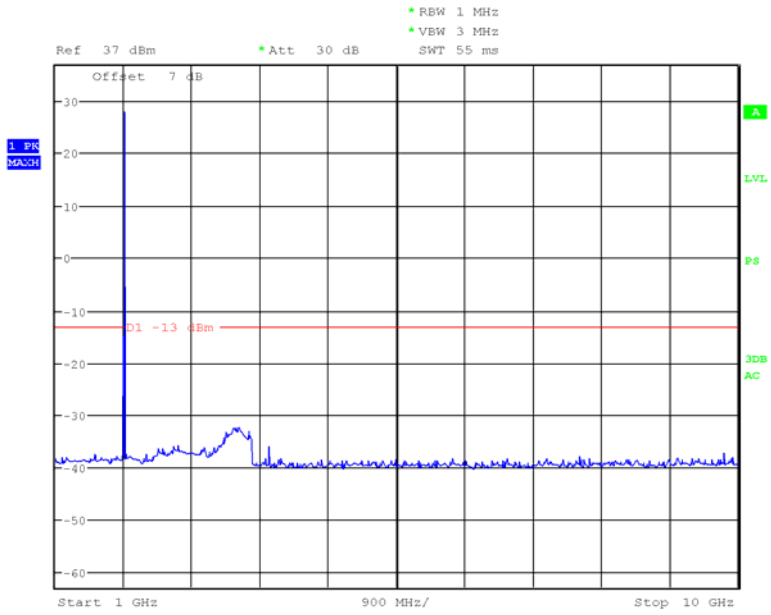

## 11 FIELD STRENGTH OF SPURIOUS RADIATION MEASUREMENT

### 11.1 Standard Applicable

According to FCC §2.1053,

FCC §22.917(a), §24.238(a), the magnitude of each spurious and harmonic emission that can be detected when the equipment is operated under the conditions specified in the instruction manual and/ or alignment procedure, shall not be less than  $43 + 10 \log$  (mean output power in watts) dBc below the mean power output outside a license's frequency block (-13dBm)

### 11.2 EUT Setup (Block Diagram of Configuration)

(A) Radiated Emission Test Set-Up, Frequency below 1000MHz

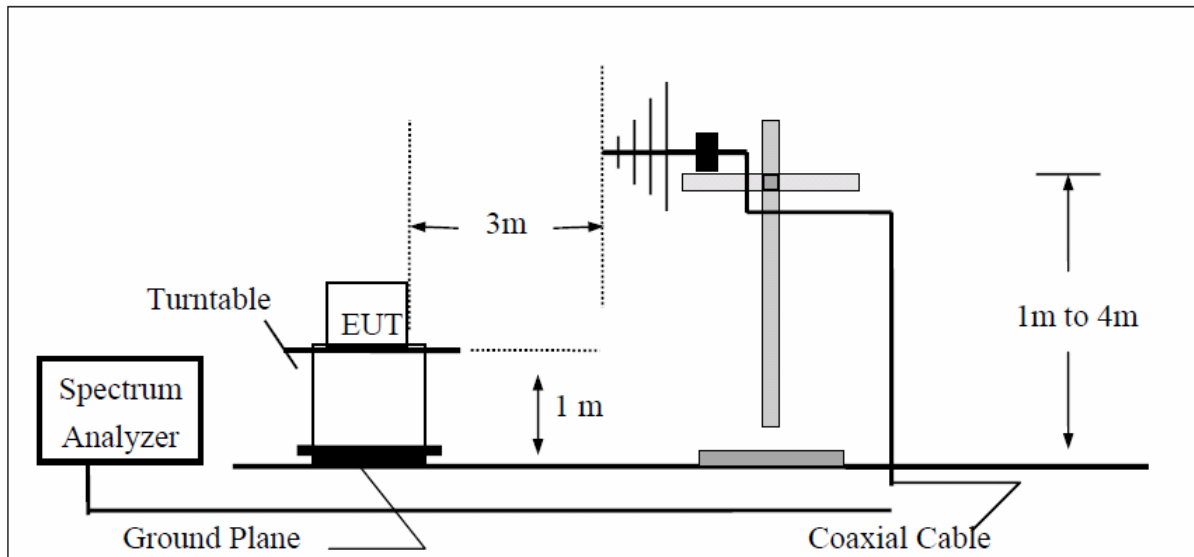

(B) Radiated Emission Test Set-UP Frequency over 1 GHz

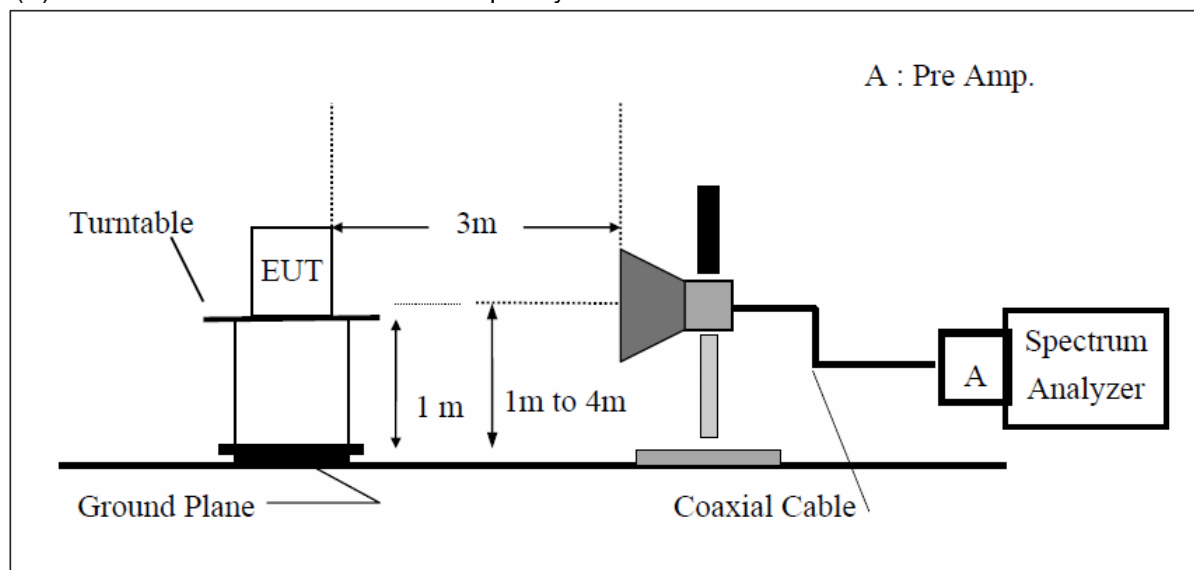

(C) Substituted Method Test Set-UP

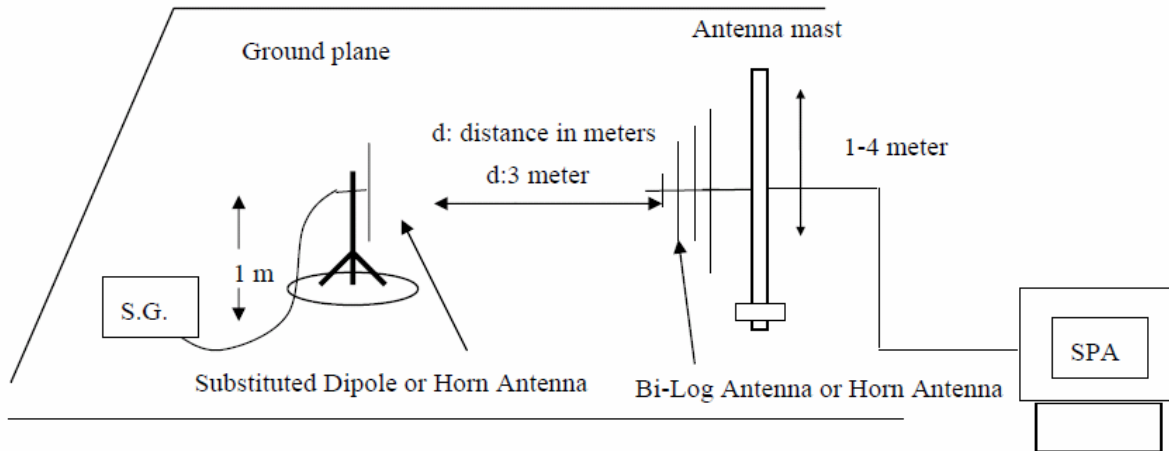

### 11.3 Measurement Procedure

The EUT was placed on a non-conductive, The measurement antenna was placed at a distance of 3 meters from the EUT. During the tests, the antenna height and the EUT azimuth were varied in order to identify the maximum level of emissions from the EUT. This maximization process was repeated with the EUT positioned in each of its three orthogonal orientations.

The frequency range up to tenth harmonic was investigated for each of three fundamental frequency (low, middle and high channels). Once spurious emission were identified, the power of the emission was determined using the substitution method.

The spurious emissions attenuation was calculated as the difference between radiated power at the fundamental frequency and the spurious emissions frequency.

$$\text{EIRP} = \text{S.G. output (dBm)} + \text{Antenna Gain(dBi)} - \text{Cable Loss (dB)}$$

### 11.4 Test Result

Test mode:	GSM850	Test channel:	128	EUT position	H
------------	--------	---------------	-----	--------------	---

Freq(MHz)	SPA reading	Ant. Pol.	S.G output (dBm)	Antenna Gain (dB/dBi)	Cable Loss (dB)	ERP/EIRP (dBm)	Limit (dBm)	Margin (dBm)
30.00	50.28	V	-54.42	-7.34	0.95	-62.71	-13.00	-49.71
101.78	45.03	V	-56.73	-7.76	1.37	-65.86	-13.00	-52.86
824.00	73.42	V	-12.58	-7.87	3.62	-24.07	-13.00	-11.07
1648.40	50.73	V	-53.85	9.29	5.23	-49.79	-13.00	-36.79
2472.60	45.47	V	-53.54	10.08	6.53	-49.99	-13.00	-36.99
3296.80	---	V					-13.00	
4121.00	---	V					-13.00	
4945.20	---	V					-13.00	
5769.40	---	V					-13.00	

Freq(MHz)	SPA reading	Ant. Pol.	S.G output (dBm)	Antenna Gain (dB/dBi)	Cable Loss (dB)	ERP/EIRP (dBm)	Limit (dBm)	Margin (dBm)
89.20	48.90	H	-57.89	-7.46	0.99	-66.34	-13.00	-53.34
371.34	47.23	H	-55.19	-7.82	2.78	-65.79	-13.00	-52.79
824.00	71.39	H	-15.00	-7.87	3.62	-26.49	-13.00	-13.49
1648.40	51.45	H	-54.37	9.29	5.23	-50.31	-13.00	-37.31
2472.60	48.79	H	-56.28	10.08	6.53	-52.73	-13.00	-39.73
3296.80	---	H					-13.00	
4121.00	---	H					-13.00	
4945.20	---	H					-13.00	
5769.40	---	H					-13.00	

Remark :

- 1 The emission behaviour belongs to narrowband spurious emission.
- 2 Remark"---" means that the emission level is too low to be measured
- 3 The result basic equation calculation is as follows:

$$\text{ERP/EIRP (dBm)} = \text{SG Setting(dBm)} + \text{Antenna Gain (dB/dBi)} - \text{Cable loss (dB)}$$



Test mode:	GSM850	Test channel:	190	EUT position	H
------------	--------	---------------	-----	--------------	---

Freq(MHz)	SPA reading	Ant. Pol.	S.G output (dBm)	Antenna Gain (dB/dBi)	Cable Loss (dB)	ERP/EIRP (dBm)	Limit (dBm)	Margin (dBm)
245.13	46.71	V	-50.13	-7.67	0.95	-58.75	-13.00	-45.75
598.37	42.39	V	-49.87	-7.83	1.37	-59.07	-13.00	-46.07
1673.20	53.87	V	-44.56	9.36	5.27	-40.47	-13.00	-27.47
2509.80	51.11	V	-51.43	10.09	6.58	-47.92	-13.00	-34.92
3346.40	52.09	V	-53.58	12.28	7.79	-49.09	-13.00	-36.09
4183.00	---	V					-13.00	
5019.60	---	V					-13.00	
5856.20	---	V					-13.00	
6692.80	---	V					-13.00	

Freq(MHz)	SPA reading	Ant. Pol.	S.G output (dBm)	Antenna Gain (dB/dBi)	Cable Loss (dB)	ERP/EIRP (dBm)	Limit (dBm)	Margin (dBm)
124.53	47.95	H	-50.32	-7.77	1.39	-59.48	-13.00	-46.48
389.56	46.62	H	-48.79	-7.84	2.79	-59.42	-13.00	-46.42
1673.20	55.72	H	-43.08	9.36	5.27	-38.99	-13.00	-25.99
2509.80	51.57	H	-52.18	10.09	6.58	-48.67	-13.00	-35.67
3346.40	49.68	H	-54.39	12.28	7.79	-49.90	-13.00	-36.90
4183.00	---	H					-13.00	
5019.60	---	H					-13.00	
5856.20	---	H					-13.00	
6692.80	---	H					-13.00	

Remark :

- 1 The emission behaviour belongs to narrowband spurious emission.
- 2 Remark”---“ means that the emission level is too low to be measured
- 3 The result basic equation calculation is as follows:

$$\text{ERP/EIRP (dBm)} = \text{SG Setting(dBm)} + \text{Antenna Gain (dB/dBi)} - \text{Cable loss (dB)}$$

Test mode:	GSM850	Test channel:	251	EUT position	H
------------	--------	---------------	-----	--------------	---

Freq(MHz)	SPA reading	Ant. Pol.	S.G output (dBm)	Antenna Gain (dB/dBi)	Cable Loss (dB)	ERP/EIRP (dBm)	Limit (dBm)	Margin (dBm)
100.78	47.43	V	-53.24	-7.77	1.38	-62.39	-13.00	-49.39
407.38	44.36	V	-52.72	-7.88	2.88	-63.48	-13.00	-50.48
849.00	68.36	V	-14.18	-7.88	3.68	-25.74	-13.00	-12.74
1697.60	51.71	V	-52.14	9.44	5.31	-48.01	-13.00	-35.01
2546.40	49.57	V	-49.51	10.20	6.63	-45.94	-13.00	-32.94
3395.20	---	V					-13.00	
4244.00	---	V					-13.00	
5092.80	---	V					-13.00	
5941.60	---	V					-13.00	

Freq(MHz)	SPA reading	Ant. Pol.	S.G output (dBm)	Antenna Gain (dB/dBi)	Cable Loss (dB)	ERP/EIRP (dBm)	Limit (dBm)	Margin (dBm)
212.57	48.28	H	-52.12	-7.68	0.96	-60.76	-13.00	-47.76
598.68	47.07	H	-51.13	-7.83	1.37	-60.33	-13.00	-47.33
824.00	66.69	H	-15.78	-7.88	3.68	-27.34	-13.00	-14.34
1648.40	53.27	H	-51.45	9.44	5.31	-47.32	-13.00	-34.32
2472.60	50.68	H	-50.68	10.20	6.63	-47.11	-13.00	-34.11
3296.80	---	H					-13.00	
4121.00	---	H					-13.00	
4945.20	---	H					-13.00	
5769.40	---	H					-13.00	

Remark :

- 1 The emission behaviour belongs to narrowband spurious emission.
- 2 Remark”---“ means that the emission level is too low to be measured
- 3 The result basic equation calculation is as follows:

$$\text{ERP/EIRP (dBm)} = \text{SG Setting(dBm)} + \text{Antenna Gain (dB/dBi)} - \text{Cable loss (dB)}$$

Test mode:	PCS1900	Test channel:	512	EUT position	H
------------	---------	---------------	-----	--------------	---

Freq(MHz)	SPA reading	Ant. Pol.	S.G output (dBm)	Antenna Gain (dB/dBi)	Cable Loss (dB)	ERP/EIRP (dBm)	Limit (dBm)	Margin (dBm)
527.54	50.28	V	-51.24	-7.83	1.37	-60.44	-13.00	-47.44
1387.27	45.03	V	-52.45	8.44	4.31	-48.32	-13.00	-35.32
1850.00	69.73	V	-29.06	9.90	5.56	-24.72	-13.00	-11.72
3700.40	53.49	V	-43.54	12.61	8.31	-39.24	-13.00	-26.24
5550.60	50.12	V	-48.63	13.23	10.33	-45.73	-13.00	-32.73
7400.80	---	V					-13.00	
9251.00	---	V					-13.00	
11101.20	---	V					-13.00	
12951.40	---	V					-13.00	

Freq(MHz)	SPA reading	Ant. Pol.	S.G output (dBm)	Antenna Gain (dB/dBi)	Cable Loss (dB)	ERP/EIRP (dBm)	Limit (dBm)	Margin (dBm)
340.34	49.57	H	-52.34	-7.38	3.18	-62.90	-13.00	-49.90
1578.41	43.69	H	-50.30	8.17	4.76	-46.89	-13.00	-33.89
1850.00	68.57	H	-30.45	9.90	5.56	-26.11	-13.00	-13.11
3700.40	51.48	H	-45.69	12.61	8.31	-41.39	-13.00	-28.39
5550.60	49.52	H	-49.39	13.23	10.33	-46.49	-13.00	-33.49
7400.80	---	H					-13.00	
9251.00	---	H					-13.00	
11101.20	---	H					-13.00	
12951.40	---	H					-13.00	

Remark :

- 1 The emission behaviour belongs to narrowband spurious emission.
- 2 Remark”---“ means that the emission level is too low to be measured
- 3 The result basic equation calculation is as follows:

$$\text{ERP/EIRP (dBm)} = \text{SG Setting(dBm)} + \text{Antenna Gain (dB/dBi)} - \text{Cable loss (dB)}$$

Test mode:	PCS1900	Test channel:	661	EUT position	H
------------	---------	---------------	-----	--------------	---

Freq(MHz)	SPA reading	Ant. Pol.	S.G output (dBm)	Antenna Gain (dB/dBi)	Cable Loss (dB)	ERP/EIRP (dBm)	Limit (dBm)	Margin (dBm)
527.54	50.28	V	-51.17	-7.83	1.37	-60.37	-13.00	-47.37
1607.43	44.03	V	-49.86	8.19	4.82	-46.49	-13.00	-33.49
3760.00	54.28	V	-44.23	12.60	8.39	-40.02	-13.00	-27.02
5640.00	50.73	V	-48.59	13.36	10.41	-45.64	-13.00	-32.64
7520.00	50.47	V	-48.45	11.45	12.19	-49.19	-13.00	-36.19
9400.00	---	V					-13.00	
11280.00	---	V					-13.00	
13160.00	---	V					-13.00	
15040.00	---	V					-13.00	

Freq(MHz)	SPA reading	Ant. Pol.	S.G output (dBm)	Antenna Gain (dB/dBi)	Cable Loss (dB)	ERP/EIRP (dBm)	Limit (dBm)	Margin (dBm)
340.34	51.56	H	-50.32	-7.38	3.18	-60.88	-13.00	-47.88
1201.45	44.28	H	-51.38	7.89	4.58	-48.07	-13.00	-35.07
3760.00	55.14	H	-43.95	12.60	8.39	-39.74	-13.00	-26.74
5640.00	51.27	H	-47.29	13.36	10.41	-44.34	-13.00	-31.34
7520.00	52.36	H	-46.87	11.45	12.19	-47.61	-13.00	-34.61
9400.00	---	H					-13.00	
11280.00	---	H					-13.00	
13160.00	---	H					-13.00	
15040.00	---	H					-13.00	

**Remark :**

- 1 The emission behaviour belongs to narrowband spurious emission.
- 2 Remark"---" means that the emission level is too low to be measured
- 3 The result basic equation calculation is as follows:

$$\text{ERP/EIRP (dBm)} = \text{SG Setting(dBm)} + \text{Antenna Gain (dB/dBi)} - \text{Cable loss (dB)}$$

Test mode:	PCS1900	Test channel:	810	EUT position	H
------------	---------	---------------	-----	--------------	---

Freq(MHz)	SPA reading	Ant. Pol.	S.G output (dBm)	Antenna Gain (dB/dBi)	Cable Loss (dB)	ERP/EIRP (dBm)	Limit (dBm)	Margin (dBm)
527.54	50.28	V	-51.24	-7.83	1.37	-60.44	-13.00	-47.44
1388.22	45.03	V	-50.06	7.56	4.56	-47.06	-13.00	-34.06
1910.00	68.74	V	-28.49	10.08	5.66	-24.07	-13.00	-11.07
3819.60	48.93	V	-47.52	12.60	8.69	-43.61	-13.00	-30.61
5729.40	49.25	V	-48.19	13.86	10.73	-45.06	-13.00	-32.06
7639.20	---	V					-13.00	
9549.00	---	V					-13.00	
11458.80	---	V					-13.00	
13368.60	---	V					-13.00	

Freq(MHz)	SPA reading	Ant. Pol.	S.G output (dBm)	Antenna Gain (dB/dBi)	Cable Loss (dB)	ERP/EIRP (dBm)	Limit (dBm)	Margin (dBm)
340.34	49.57	H	-52.08	-7.38	3.18	-62.64	-13.00	-49.64
895.39	46.23	H	-49.80	-7.84	3.68	-61.32	-13.00	-48.32
1910.00	66.98	H	-30.17	10.08	5.66	-25.75	-13.00	-12.75
3819.60	47.13	H	-49.89	12.60	8.69	-45.98	-13.00	-32.98
5729.40	48.38	H	-51.38	13.86	10.73	-48.25	-13.00	-35.25
7639.20	---	H					-13.00	
9549.00	---	H					-13.00	
11458.80	---	H					-13.00	
13368.60	---	H					-13.00	

Remark :

- 1 The emission behaviour belongs to narrowband spurious emission.
- 2 Remark"---" means that the emission level is too low to be measured
- 3 The result basic equation calculation is as follows:

$$\text{ERP/EIRP (dBm)} = \text{SG Setting(dBm)} + \text{Antenna Gain (dB/dBi)} - \text{Cable loss (dB)}$$

## 12 FREQUENCY STABILITY V.S. TEMPERATURE MEASUREMENT

### 12.1 Standard Applicable

According to FCC §2.1055(a)(1)(b).

Frequency Tolerance: 2.5 ppm

### 12.2 Test setup

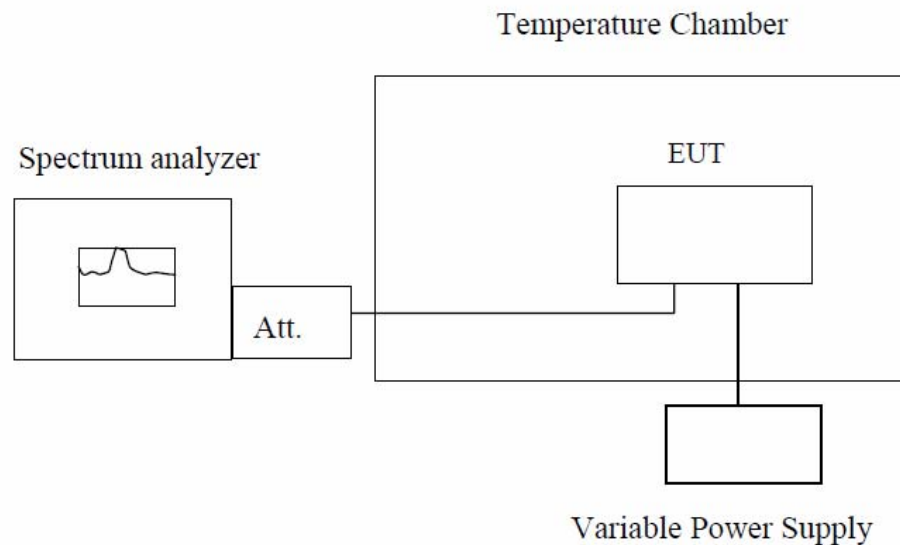

**Note :** Measurement setup for testing on Antenna connector

### 12.3 Test Procedure

The equipment under test was connected to an external AC or DC power supply and input rated voltage. RF output was connected to a frequency counter or spectrum analyzer via feed through attenuators. The EUT was placed inside the temperature chamber. Set the spectrum analyzer RBW low enough to obtain the desired frequency resolution and measure EUT 25°C operating frequency as reference frequency. Turn EUT off and set the chamber temperature to -30°C. After the temperature stabilized for approximately 30 minutes recorded the frequency. Repeat step measure with 10°C increased per stage until the highest temperature of +50°C reached.

### 12.4 Test Result

Reference Frequency: GSM850 Middle channel=190 channel=836.6MHz				
Temperature (°C)	Power Supplied (Vdc)	Frequency Error (Hz)	Frequency Error (ppm)	Limit (ppm)
-20	3.7	21	0.0251	2.5
-10	3.7	22	0.0263	2.5
0	3.7	20	0.0239	2.5
20	3.7	23	0.0275	2.5
40	3.7	25	0.0299	2.5
55	3.7	23	0.0275	2.5
25	3.5	21	0.0251	2.5

Reference Frequency: PCS1900 Middle channel=661 channel=1880MHz				
Temperature (°C)	Power Supplied (Vdc)	Frequency Error (Hz)	Frequency Error (ppm)	Limit (ppm)
-20	3.7	29	0.0154	2.5
-10	3.7	31	0.0165	2.5
0	3.7	30	0.0160	2.5
20	3.7	33	0.0176	2.5
40	3.7	30	0.0160	2.5
55	3.7	26	0.0138	2.5
25	3.5	27	0.0144	2.5

## 13 FREQUENCY STABILITY V.S. VOLTAGE MEASUREMENT

### 13.1 Standard Applicable

According to FCC §2.1055(d)(1)(2).

Frequency Tolerance: 2.5 ppm

### 13.2 Test setup

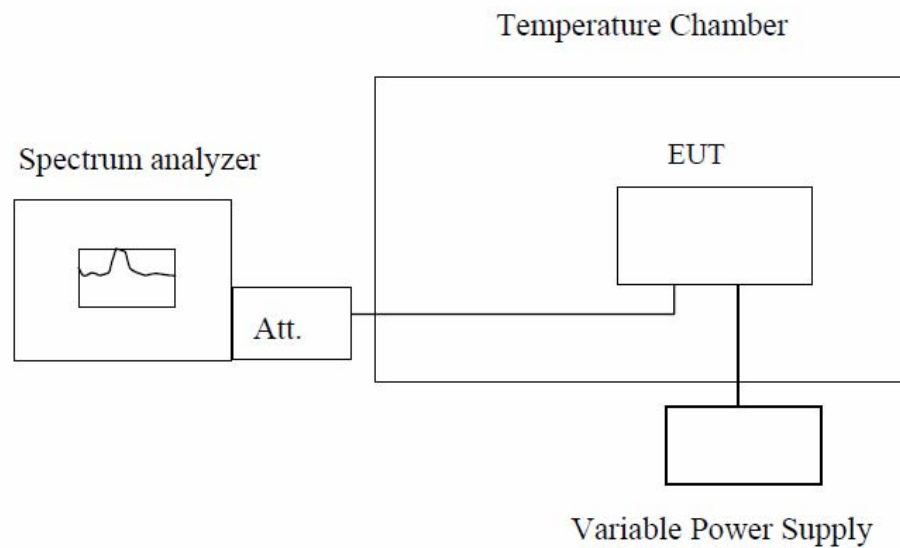

**Note :** Measurement setup for testing on Antenna connector

### 13.3 Test Procedure

Set chamber temperature to 25°C. Use a variable AC power supply / DC power source to power the EUT and set the voltage to rated voltage. Set the spectrum analyzer RBW low enough to obtain the desired frequency resolution and recorded the frequency.

Reduce the input voltage to specified extreme voltage variation (+/- 15%) and endpoint, record the maximum frequency change.



### 13.4 Test Result

Reference Frequency: GSM850 Middle channel=190 channel=836.6MHz				
Temperature (°C)	Power Supplied (Vdc)	Frequency Error (Hz)	Frequency Error (ppm)	Limit (ppm)
25	4.25	21	0.0112	2.5
25	3.70	23	0.0122	2.5
25	3.40	20	0.0106	2.5

Reference Frequency: PCS1900 Middle channel=661 channel=1880MHz				
Temperature (°C)	Power Supplied (Vdc)	Frequency Error (Hz)	Frequency Error (ppm)	Limit (ppm)
25	4.25	34	0.0406	2.5
25	3.70	33	0.0394	2.5
25	3.40	41	0.0490	2.5

## 14 AC POWER LINE CONDUCTED EMISSION TEST

### 14.1 Standard Applicable

According to FCC §15.207. The emission value for frequency within 150KHz to 30MHz shall not Exceed criteria of below chart.

Frequency range (MHz)	Limits dB(uV)	
	Quasi-peak	Average
0.15 to 0.50	66 to 56	56 to 46
0.50 to 5	56	46
5 to 30	60	50
Note 1.The lower limit shall apply at the transition frequencies 2.The limit decreases linearly with the logarithm of the frequency in the range 0.15 MHz to 0.50 MHz.		

### 14.2 Test setup

1. The conducted emission tests were performed in the test site, using the setup in accordance with the ANSI C63.4-2001.
2. The EUT was plug-in DC power adaptor and was placed on the center of the back edge on the test table. The peripherals like earphone was placed on the side of the EUT. The rear of the EUT and peripherals were placed flushed with the rear of the tabletop.
3. The Power adaptor was connected with 110Vac/60Hz power source.

### 14.3 Test Procedure

1. The EUT was placed on a table which is 0.8m above ground plane.
2. Maximum procedure was performed on the six highest emissions to ensure EUT compliance.
3. Repeat above procedures until all frequency measured were complete.

### 14.4 Measurement Result

Test mode: GSM850

Line

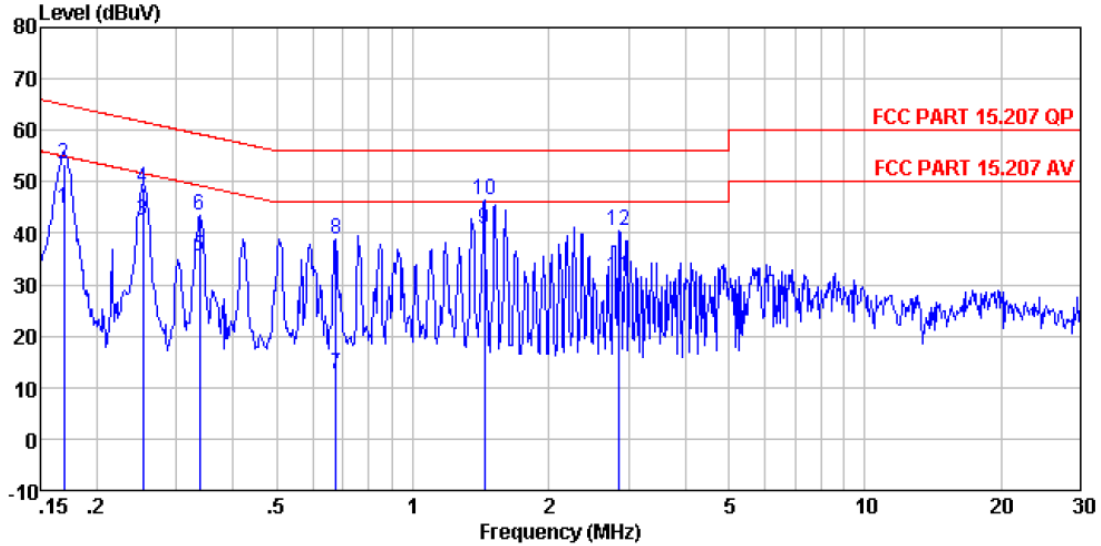

Condition : FCC PART 15.207 QP LISN LINE  
 Manufacturer : Verykool  
 EUT: : GSM Dual Band GPRS Digital Mobile Phone  
 Model: : i600  
 Power: : DC 5V By adapter input AC 120V/60Hz  
 Test mode: : Charging and GSM850  
 Environmental: : Temp:25.5 ℃; Humi: 45%  
 Test engineer: : David

	Freq	Read Level	LISN Factor	Cable Loss	Level	Limit Line	Over Limit	Remark
	MHz	dBuV	dB	dB	dBuV	dBuV	dB	
1	0.17	41.20	3.67	0.01	44.88	54.99	-10.11	Average
2	0.17	49.80	3.67	0.01	53.48	64.99	-11.51	QP
3	0.25	38.90	3.63	0.01	42.54	51.64	-9.10	Average
4	0.25	45.00	3.63	0.01	48.64	61.64	-13.00	QP
5	0.34	32.00	3.60	0.01	35.61	49.27	-13.66	Average
6	0.34	39.70	3.60	0.01	43.31	59.27	-15.96	QP
7	0.68	9.00	3.52	0.01	12.53	46.00	-33.47	Average
8	0.68	35.38	3.52	0.01	38.91	56.00	-17.09	QP
9	1.44	37.40	3.44	0.04	40.88	46.00	-5.12	Average
10	1.44	42.86	3.44	0.04	46.34	56.00	-9.66	QP
11	2.85	28.00	3.36	0.19	31.55	46.00	-14.45	Average
12	2.85	36.90	3.36	0.19	40.45	56.00	-15.55	QP

**Neutral:**

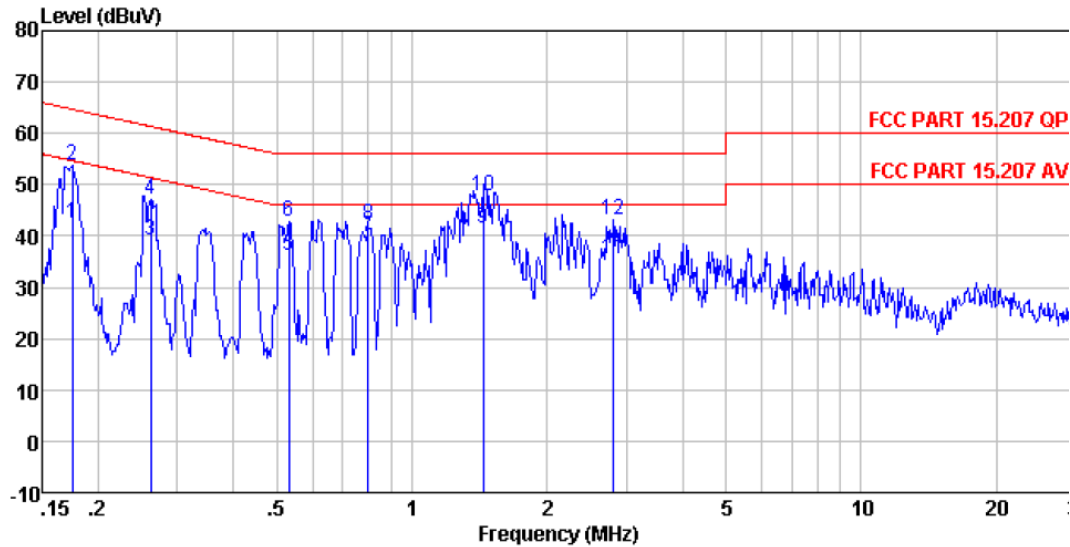

Condition : FCC PART 15.207 QP LISN NEUTRAL  
 Manufacturer : Verykool  
 EUT: : GSM Dual Band GPRS Digital Mobile Phone  
 Model: : i600  
 Power: : DC 5V By adapter input AC 120V/60Hz  
 Test mode: : Charging and GSM850  
 Environmental: : Temp:25.5 °C; Humi: 45%  
 Test engineer: : David

	Read Freq	LISN Level	Cable Factor	Cable Loss	Limit Level	Over Line	Over Limit	Remark
	MHz	dBuV	dB	dB	dBuV	dBuV	dB	
1	0.17	38.90	3.67	0.01	42.58	54.72	-12.14	Average
2	0.17	50.02	3.67	0.01	53.70	64.72	-11.02	QP
3	0.26	35.60	3.63	0.01	39.24	51.38	-12.14	Average
4	0.26	43.38	3.63	0.01	47.02	61.38	-14.36	QP
5	0.53	32.60	3.55	0.01	36.16	46.00	-9.84	Average
6	0.53	39.32	3.55	0.01	42.88	56.00	-13.12	QP
7	0.80	36.40	3.50	0.01	39.91	46.00	-6.09	Average
8	0.80	38.58	3.50	0.01	42.09	56.00	-13.91	QP
9	1.44	38.00	3.44	0.04	41.48	46.00	-4.52	Average
10	1.44	44.20	3.44	0.04	47.68	56.00	-8.32	QP
11	2.81	32.11	3.36	0.18	35.65	46.00	-10.35	Average
12	2.81	39.49	3.36	0.18	43.03	56.00	-12.97	QP

Test mode: PCS1900

Line:

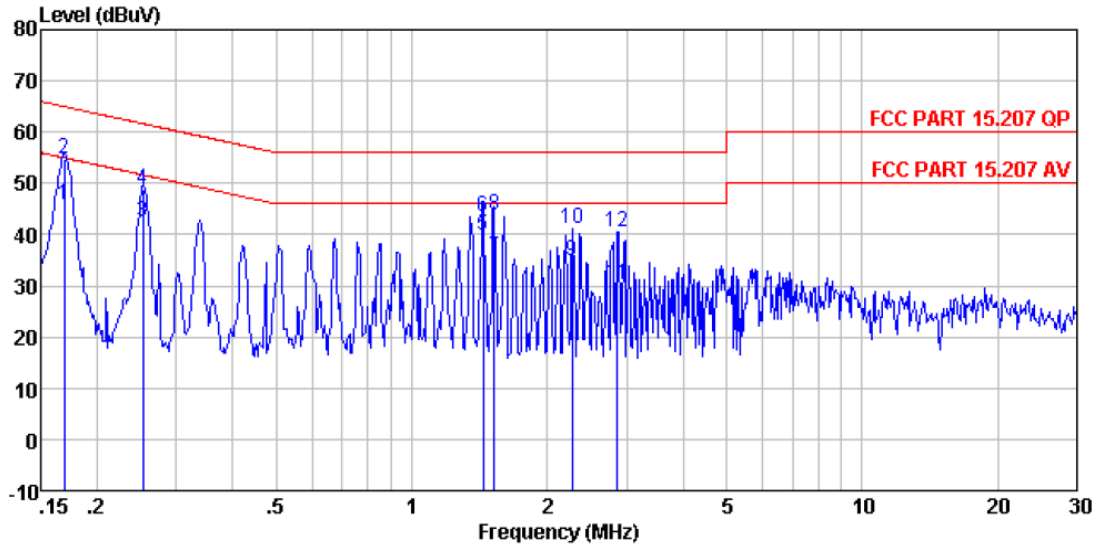

Condition : FCC PART 15.207 QP LISN LINE  
 Manufacturer : Verykool  
 EUT: : GSM Dual Band GPRS Digital Mobile Phone  
 Model: : i600  
 Power: : DC 5V By adapter input AC 120V/60Hz  
 Test mode: : Charging and PCS1900  
 Environmental:: Temp:25.5 °C; Humi: 45%  
 Test engineer:: David

	Freq	Read Level	LISN Factor	Cable Loss	Level	Limit Line	Over Limit	Remark
	MHz	dBuV	dB	dB	dBuV	dBuV	dB	
1	0.17	42.00	3.67	0.01	45.68	54.99	-9.31	Average
2	0.17	51.20	3.67	0.01	54.88	64.99	-10.11	QP
3	0.25	38.90	3.63	0.01	42.54	51.64	-9.10	Average
4	0.25	45.20	3.63	0.01	48.84	61.64	-12.80	QP
5	1.44	36.20	3.44	0.04	39.68	46.00	-6.32	Average
6	1.44	40.12	3.44	0.04	43.60	56.00	-12.40	QP
7	1.53	32.10	3.43	0.06	35.59	46.00	-10.41	Average
8	1.53	40.20	3.43	0.06	43.69	56.00	-12.31	QP
9	2.27	31.19	3.39	0.14	34.72	46.00	-11.28	Average
10	2.27	37.55	3.39	0.14	41.08	56.00	-14.92	QP
11	2.85	26.70	3.36	0.19	30.25	46.00	-15.75	Average
12	2.85	36.98	3.36	0.19	40.53	56.00	-15.47	QP

Neutral:

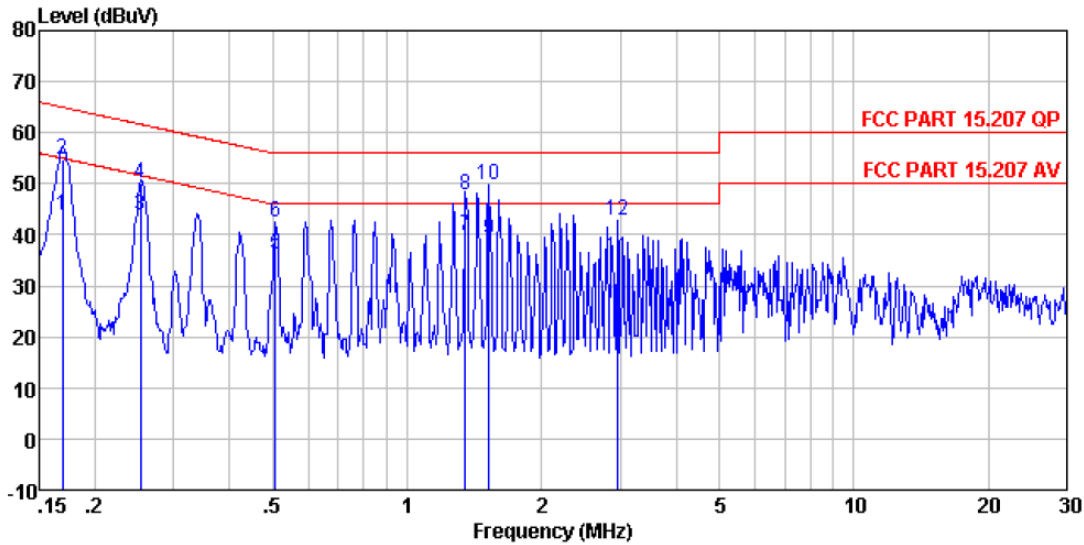

Condition : FCC PART 15.207 QP LISN NEUTRAL  
 Manufacturer : Verykool  
 EUT: : GSM Dual Band GPRS Digital Mobile Phone  
 Model: : i600  
 Power: : DC 5V By adapter input AC 120V/60Hz  
 Test mode: : Charging and PCS1900  
 Environmental: : Temp:25.5 °C; Humi: 45%  
 Test engineer: : David

	Read Freq	LISN Level	Cable Factor	Cable Loss	Limit Level	Over Line	Over Limit	Remark
	MHz	dBuV	dB	dB	dBuV	dBuV	dB	
1	0.17	40.10	3.67	0.01	43.78	54.99	-11.21	Average
2	0.17	51.20	3.67	0.01	54.88	64.99	-10.11	QP
3	0.25	40.20	3.63	0.01	43.84	51.64	-7.80	Average
4	0.25	46.50	3.63	0.01	50.14	61.64	-11.50	QP
5	0.51	32.50	3.55	0.01	36.06	46.00	-9.94	Average
6	0.51	38.80	3.55	0.01	42.36	56.00	-13.64	QP
7	1.35	36.21	3.44	0.02	39.67	46.00	-6.33	Average
8	1.35	44.21	3.44	0.02	47.67	56.00	-8.33	QP
9	1.53	35.60	3.43	0.06	39.09	46.00	-6.91	Average
10	1.53	46.40	3.43	0.06	49.89	56.00	-6.11	QP
11	2.95	32.09	3.36	0.20	35.65	46.00	-10.35	Average
12	2.95	39.27	3.36	0.20	42.83	56.00	-13.17	QP