

FCC REPORT (Bluetooth)

Applicant: VeryKool USA Inc

Address of Applicant: 4350 Executive Dr.#100, San Diego

Equipment Under Test (EUT)

Product Name: GSM Quad Band GPRS Digital Mobile Phone

Model No.: i310

Trade mark: Verykool

FCC ID: WA6I310

Applicable standards: FCC CFR Title 47 Part 15 Subpart C Section 15.247:2010

Date of sample receipt: 12 May, 2011

Date of Test: 12-17 May, 2011

Date of report issued: 18 May, 2011

Test Result : PASS *

* In the configuration tested, the EUT complied with the standards specified above.

Authorized Signature:



Robinson Lo
Laboratory Manager

This report details the results of the testing carried out on one sample. The results contained in this test report do not relate to other samples of the same product and does not permit the use of the GTS product certification mark. The manufacturer should ensure that all products in series production are in conformity with the product sample detailed in this report.

This report may only be reproduced and distributed in full. If the product in this report is used in any configuration other than that detailed in the report, the manufacturer must ensure the new system complies with all relevant standards. Any mention of GTS International Electrical Approvals or testing done by GTS International Electrical Approvals in connection with, distribution or use of the product described in this report must be approved by GTS International Electrical Approvals in writing.

This document cannot be reproduced except in full, without prior written approval of the Company. Any unauthorized alteration, forgery or falsification of the content or appearance of this document is unlawful and offenders may be prosecuted to the fullest extent of the law. Unless otherwise stated the results shown in this test report refer only to the sample(s) tested and such sample(s) are retained for 90 days only."

2 Version

Version No.	Date	Description
<i>00</i>	<i>2011-05-18</i>	<i>Original</i>

Prepared By: Collin.He **Date:** 2011-05-18

Project Engineer

Check By: Hans.Hu **Date:** 2011-05-18

Reviewer

3 Contents

	Page
1 COVER PAGE	1
2 VERSION	2
3 CONTENTS	3
4 TEST SUMMARY	4
5 GENERAL INFORMATION	5
5.1 CLIENT INFORMATION	5
5.2 GENERAL DESCRIPTION OF E.U.T.....	5
5.3 TEST ENVIRONMENT AND MODE	7
5.4 TEST FACILITY.....	7
5.5 TEST LOCATION.....	7
5.6 OTHER INFORMATION REQUESTED BY THE CUSTOMER	7
5.7 TEST INSTRUMENTS LIST.....	8
6 TEST RESULTS AND MEASUREMENT DATA	9
6.1 ANTENNA REQUIREMENT:.....	9
6.2 CONDUCTED EMISSIONS	10
6.3 CONDUCTED PEAK OUTPUT POWER.....	13
6.4 20dB OCCUPY BANDWIDTH	20
6.5 CARRIER FREQUENCIES SEPARATION	26
6.6 HOPPING CHANNEL NUMBER.....	33
6.7 DWELL TIME.....	36
6.8 BAND EDGE	39
6.9 RF ANTENNA CONDUCTED SPURIOUS EMISSIONS	41
6.10 PSEUDORANDOM FREQUENCY HOPPING SEQUENCE	45
6.11 RADIATED EMISSION	46
6.11.1 Radiated emission below 1GHz.....	48
6.11.2 Transmitter emission above 1GHz.....	49
7 TEST SETUP PHOTO	52
8 EUT CONSTRUCTIONAL DETAILS	54

4 Test Summary

Test Item	Section in CFR 47	Result
Antenna Requirement	15.203/15.247 (c)	PASS
AC Power Line Conducted Emission	15.207	PASS
Conducted Peak Output Power	15.247 (b)(1)	PASS
20dB Occupied Bandwidth	15.247 (a)(1)	PASS
Carrier Frequencies Separation	15.247 (a)(1)	PASS
Hopping Channel Number	15.247 (a)(1)	PASS
Dwell Time	15.247 (a)(1)	PASS
Pseudorandom Frequency Hopping Sequence	15.247(b)(4)&TCB Exclusion List (7 July 2002)	PASS
Radiated Emission	15.205/15.209	PASS
Band Edge	15.247(d)	PASS

Remark:

- *Pass: The EUT complies with the essential requirements in the standard.*

5 General Information

5.1 Client Information

Applicant:	VeryKool USA Inc
Address of Applicant:	4350 Executive Dr.#100, San Diego
Manufacturer/Factory:	Shenzhen Konka Telecommunications Technology Co., Ltd.
Address of Manufacturer/Factory:	No.9008 Shennan Road, Overseas Chinese Town, Shenzhen, Guangdong, China

5.2 General Description of E.U.T.

Product Name:	GSM Quad Band GPRS Digital Mobile Phone
Model No.:	i310
Operation Frequency:	2402MHz~2480MHz
Channel numbers:	79
Channel separation:	1MHz
Modulation type:	GFSK, Pi/4QPSK, 8DPSK
Antenna Type:	Integral
Antenna gain:	2dBi
Power supply:	DC 3.7V by battery

Operation Frequency each of channel							
Channel	Frequency	Channel	Frequency	Channel	Frequency	Channel	Frequency
1	2402MHz	21	2422MHz	41	2442MHz	61	2462MHz
2	2403MHz	22	2423MHz	42	2443MHz	62	2463MHz
3	2404MHz	23	2424MHz	43	2444MHz	63	2464MHz
4	2405MHz	24	2425MHz	44	2445MHz	64	2465MHz
5	2406MHz	25	2426MHz	45	2446MHz	65	2466MHz
6	2407MHz	26	2427MHz	46	2447MHz	66	2467MHz
7	2408MHz	27	2428MHz	47	2448MHz	67	2468MHz
8	2409MHz	28	2429MHz	48	2449MHz	68	2469MHz
9	2410MHz	29	2430MHz	49	2450MHz	69	2470MHz
10	2411MHz	30	2431MHz	50	2451MHz	70	2471MHz
11	2412MHz	31	2432MHz	51	2452MHz	71	2472MHz
12	2413MHz	32	2433MHz	52	2453MHz	72	2473MHz
13	2414MHz	33	2434MHz	53	2454MHz	73	2474MHz
14	2415MHz	34	2435MHz	54	2455MHz	74	2475MHz
15	2416MHz	35	2436MHz	55	2456MHz	75	2476MHz
16	2417MHz	36	2437MHz	56	2457MHz	76	2477MHz
17	2418MHz	37	2438MHz	57	2458MHz	77	2478MHz
18	2419MHz	38	2439MHz	58	2459MHz	78	2479MHz
19	2420MHz	39	2440MHz	59	2460MHz	79	2480MHz
20	2421MHz	40	2441MHz	60	2461MHz		

Note:

In section 15.31(m), regards to the operating frequency range over 10 MHz, the Lowest frequency, the middle frequency, and the highest frequency of channel were selected to perform the test, and the selected channel see below:

Channel	Frequency
The lowest channel	2402MHz
The middle channel	2441MHz
The Highest channel	2480MHz

5.3 Test environment and mode

Operating Environment:	
Temperature:	25.0 °C
Humidity:	45 % RH
Atmospheric Pressure:	1050 mbar
Test mode:	
Bluetooth mode	Keep the EUT in communicating mode by Bluetooth function
Communicate mode	Keep the EUT in communicating mode with 850MHz band.
Communicate mode	Keep the EUT in communicating mode with 1900MHz band.

5.4 Test Facility

<p>The test facility is recognized, certified, or accredited by the following organizations:</p> <ul style="list-style-type: none"> ● FCC —Registration No.: 600491 Global United Technology Services Co., Ltd., Shenzhen EMC Laboratory has been registered and fully described in a report filed with the (FCC) Federal Communications Commission. The acceptance letter from the FCC is maintained in files. Registration 600491, July 20, 2010. ● Industry Canada (IC) The 3m Semi-anechoic chamber of Global United Technology Services Co., Ltd. has been Registered by Certification and Engineering Bureau of Industry Canada for radio equipment testing with Registration No.: 9079A-1.

5.5 Test Location

All tests were performed at:
<p>Global United Technology Services Co., Ltd. Address: 2nd Floor, Block No.2, Laodong Industrial Zone, Xixiang Road Baoan District, Shenzhen, China Tel: 0755-27798480 Fax: 0755-27798960</p>

5.6 Other Information Requested by the Customer

None.

5.7 Test Instruments list

Radiated Emission:						
Item	Test Equipment	Manufacturer	Model No.	Inventory No.	Cal.Date (mm-dd-yy)	Cal.Due date (mm-dd-yy)
1	3m Semi-Anechoic Chamber	ZhongYu Electron	9.2(L)*6.2(W)* 6.4(H)	GTS201	Mar. 30 2011	Mar. 30 2012
2	Control Room	ZhongYu Electron	6.2(L)*2.5(W)* 2.4(H)	GTS202	N/A	N/A
3	EMI Test Receiver	Rohde & Schwarz	ESU26	GTS203	Sept. 10 2010	Sept. 10 2011
4	BiConiLog Antenna	SCHWARZBECK MESS-ELEKTRONIK	VULB9163	GTS204	Feb. 26 2011	Feb. 26 2012
5	Double -ridged waveguide horn	SCHWARZBECK MESS-ELEKTRONIK	9120D-829	GTS205	June 30 2010	June 30 2011
6	EMI Test Software	AUDIX	E3	N/A	N/A	N/A
7	Coaxial Cable	GTS	N/A	GTS400	Apr. 01 2011	Apr. 01 2012
8	Coaxial Cable	GTS	N/A	GTS401	Apr. 01 2011	Apr. 01 2012
9	Coaxial cable	GTS	N/A	GTS402	Apr. 01 2011	Apr. 01 2012
10	Coaxial Cable	GTS	N/A	GTS407	Apr. 01 2011	Apr. 01 2012
11	Coaxial Cable	GTS	N/A	GTS408	Apr. 01 2011	Apr. 01 2012
12	Amplifier(10KHz-5GHz)	Sonnoma Instrument	305-1052	GTS210	Apr. 01 2011	Apr. 01 2012
13	Amplifier(2GHz-20GHz)	HP	8349B	GTS231	Apr. 01 2011	Apr. 01 2012
14	Universal radio communication tester	Rohde & Schwarz	CMU200	GTS235	May 11 2011	May 11 2012
15	Signal Generator	Rohde & Schwarz	SML03	GTS236	May 11 2011	May 11 2012
16	Temp. Humidity/Barometer	Oregon Scientific	BA-888	GTS248	May 11 2011	May 11 2012
17	D.C. Power Supply	Instek	PS-3030	GTS232	NA	NA
18	Splitter	Agilent	11636B	GTS237	May 11 2011	May 11 2012

Conducted Emission:						
Item	Test Equipment	Manufacturer	Model No.	Inventory No.	Cal.Date (mm-dd-yy)	Cal.Due date (mm-dd-yy)
1	Shielding Room	ZhongYu Electron	7.0(L)x3.0(W)x3.0(H)	GTS206	Apr. 10 2011	Apr. 10 2012
2	EMI Test Receiver	Rohde & Schwarz	ESCS30	GTS208	Sept. 14 2010	Sept. 14 2011
3	10dB Pulse Limita	Rohde & Schwarz	N/A	GTS209	Sept. 14 2010	Sept. 14 2011
4	LISN	SCHWARZBECK MESS-ELEKTRONIK	NSLK 8127	GTS207	Apr. 14 2011	Apr. 14 2012
5	Coaxial Cable	GTS	N/A	GTS406	Apr. 01 2011	Apr. 01 2012
6	EMI Test Software	AUDIX	E3	N/A	N/A	N/A

6 Test results and Measurement Data

6.1 Antenna requirement:

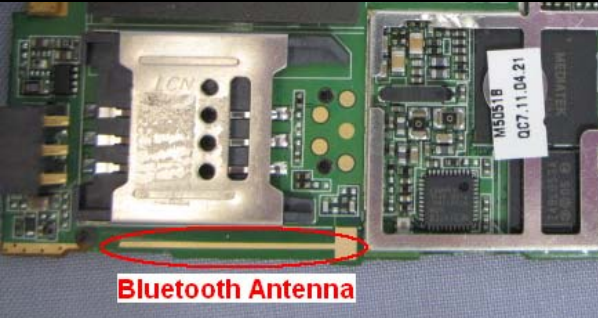
Standard requirement:	FCC Part15 C Section 15.203 /247(c)
<p><i>15.203 requirement:</i> <i>An intentional radiator shall be designed to ensure that no antenna other than that furnished by the responsible party shall be used with the device. The use of a permanently attached antenna or of an antenna that uses a unique coupling to the intentional radiator, the manufacturer may design the unit so that a broken antenna can be replaced by the user, but the use of a standard antenna jack or electrical connector is prohibited.</i></p> <p><i>15.247(c) (1)(i) requirement:</i> <i>(i) Systems operating in the 2400-2483.5 MHz band that is used exclusively for fixed. Point-to-point operations may employ transmitting antennas with directional gain greater than 6dBi provided the maximum conducted output power of the intentional radiator is reduced by 1 dB for every 3 dB that the directional gain of the antenna exceeds 6dBi.</i></p>	
E.U.T Antenna:	
<p><i>The antenna is integrated on the main PCB and no consideration of replacement. The best case gain of the antenna is 2dBi.</i></p>	
 <p>Bluetooth Antenna</p>	

6.2 Conducted Emissions

Test Requirement:	FCC Part15 C Section 15.207														
Test Method:	ANSI C63.4: 2003														
Test Frequency Range:	150KHz to 30MHz														
Class / Severity:	Class B														
Receiver setup:	RBW=9KHz, VBW=30KHz														
Limit:	<table border="1"> <thead> <tr> <th rowspan="2">Frequency range (MHz)</th> <th colspan="2">Limit (dBuV)</th> </tr> <tr> <th>Quasi-peak</th> <th>Average</th> </tr> </thead> <tbody> <tr> <td>0.15-0.5</td> <td>66 to 56*</td> <td>56 to 46*</td> </tr> <tr> <td>0.5-5</td> <td>56</td> <td>46</td> </tr> <tr> <td>5-30</td> <td>60</td> <td>50</td> </tr> </tbody> </table> <p>* Decreases with the logarithm of the frequency.</p>	Frequency range (MHz)	Limit (dBuV)		Quasi-peak	Average	0.15-0.5	66 to 56*	56 to 46*	0.5-5	56	46	5-30	60	50
Frequency range (MHz)	Limit (dBuV)														
	Quasi-peak	Average													
0.15-0.5	66 to 56*	56 to 46*													
0.5-5	56	46													
5-30	60	50													
Test procedure	The E.U.T and simulators are connected to the main power through a line impedance stabilization network(L.I.S.N.). The provide a 50ohm/50uH coupling impedance for the measuring equipment. The peripheral devices are also connected to the main power through a LISN that provides a 50ohm/50uH coupling impedance with 50ohm termination. (Please refers to the block diagram of the test setup and photographs). Both sides of A.C. line are checked for maximum conducted interference. In order to find the maximum emission, the relative positions of equipment and all of the interface cables must be changed according to ANSI C63.4: 2003 on conducted measurement.														
Test setup:	<p><i>Remark:</i> E.U.T: Equipment Under Test LISN: Line Impedance Stabilization Network Test table height=0.8m</p>														
Test Instruments:	Refer to section 5.7 for details														
Test mode:	Refer to section 5.3 for details														
Test results:	Passed														

Measurement Result:

Test mode: Bluetooth mode

Line:

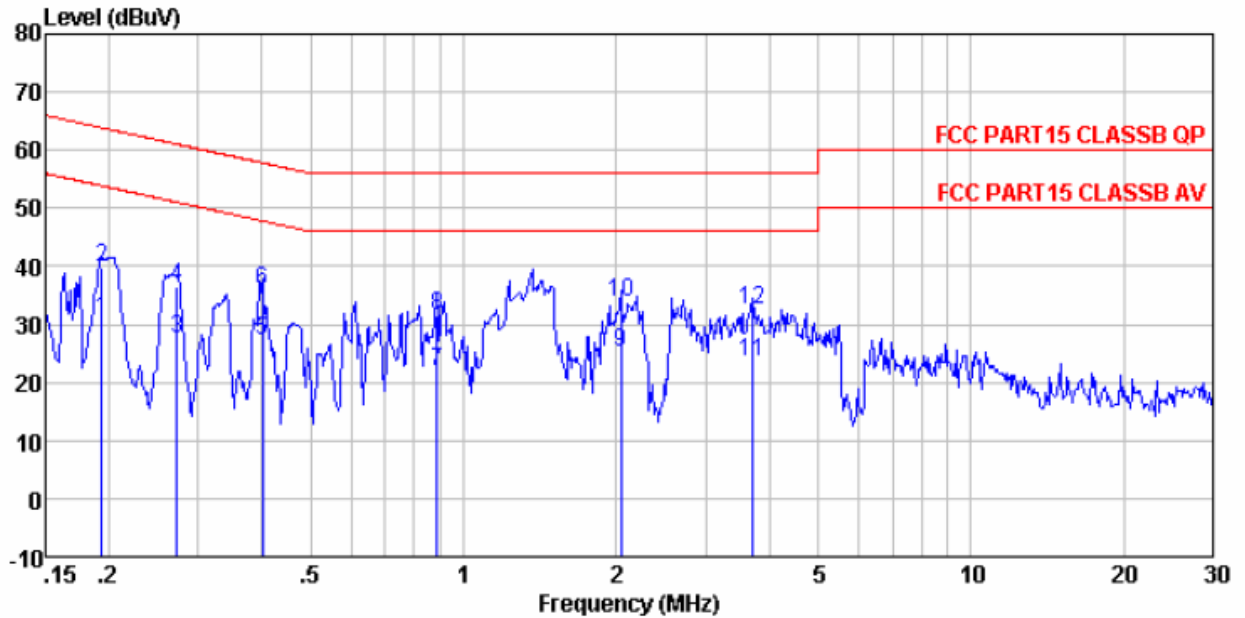

Condition : FCC PART15 CLASSB QP LISN(2011) LINE
 Job No. : 325RF
 Test Mode : Bluetooth mode
 Test Engineer: Collin

	Read	LISN	Cable	Limit	Over		
Freq	Level	Factor	Loss	Line	Limit	Remark	
MHz	dBuV	dB	dB	dBuV	dB		
1	0.193	30.12	0.66	0.10	30.88	53.89	-23.01 Average
2	0.193	38.90	0.66	0.10	39.66	63.89	-24.23 QP
3	0.273	26.89	0.62	0.10	27.61	51.03	-23.42 Average
4	0.273	35.91	0.62	0.10	36.63	61.03	-24.40 QP
5	0.402	26.48	0.58	0.10	27.16	47.81	-20.65 Average
6	0.402	35.03	0.58	0.10	35.71	57.81	-22.10 QP
7	0.885	21.18	0.49	0.10	21.77	46.00	-24.23 Average
8	0.885	30.93	0.49	0.10	31.52	56.00	-24.48 QP
9	2.044	24.78	0.40	0.10	25.28	46.00	-20.72 Average
10	2.044	33.25	0.40	0.10	33.75	56.00	-22.25 QP
11	3.700	23.18	0.33	0.10	23.61	46.00	-22.39 Average
12	3.700	32.17	0.33	0.10	32.60	56.00	-23.40 QP

Neutral:

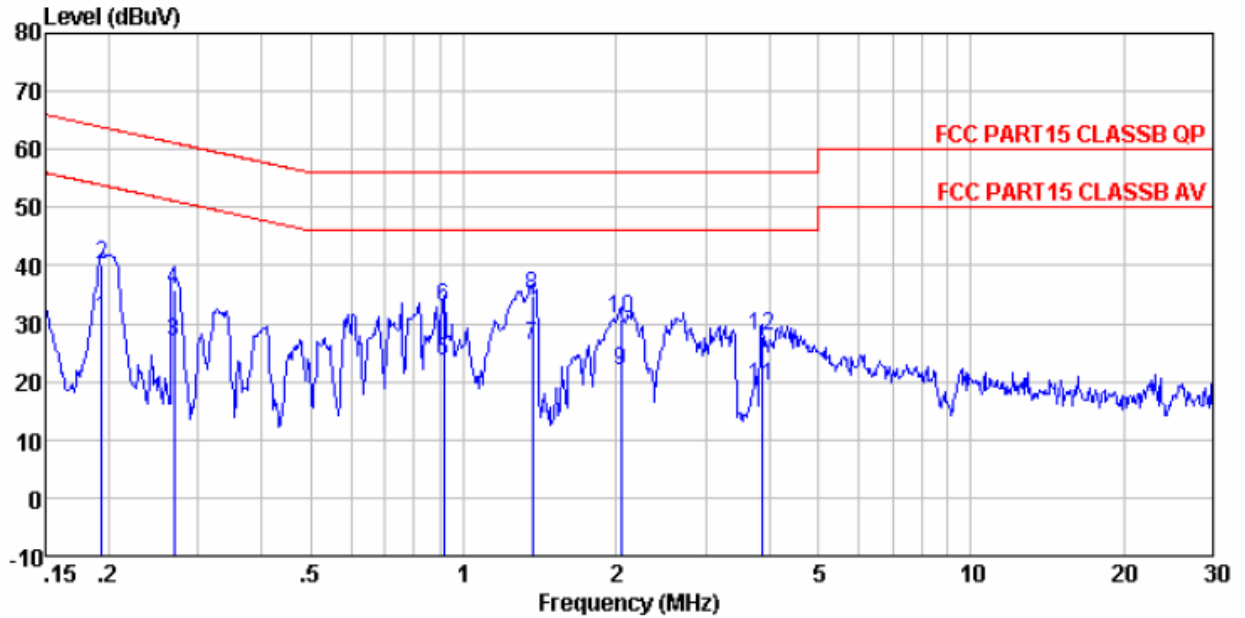

Condition : FCC PART15 CLASSB QP LISN(2011) NEUTRAL
 Job No. : 325RF
 Test Mode : Bluetooth mode
 Test Engineer: Collin

	Read Freq	Level	LISN Factor	Cable Loss	Limit Level	Over Limit	Remark
	MHz	dBuV	dB	dB	dBuV	dB	
1	0.193	30.21	0.66	0.10	30.97	53.89	-22.92 Average
2	0.193	39.54	0.66	0.10	40.30	63.89	-23.59 QP
3	0.269	26.13	0.62	0.10	26.85	51.16	-24.31 Average
4	0.269	35.13	0.62	0.10	35.85	61.16	-25.31 QP
5	0.914	23.07	0.49	0.10	23.66	46.00	-22.34 Average
6	0.914	32.18	0.49	0.10	32.77	56.00	-23.23 QP
7	1.367	25.58	0.44	0.10	26.12	46.00	-19.88 Average
8	1.367	34.38	0.44	0.10	34.92	56.00	-21.08 QP
9	2.044	21.48	0.40	0.10	21.98	46.00	-24.02 Average
10	2.044	30.42	0.40	0.10	30.92	56.00	-25.08 QP
11	3.881	18.88	0.33	0.10	19.31	46.00	-26.69 Average
12	3.881	27.27	0.33	0.10	27.70	56.00	-28.30 QP

Notes:

1. The following Quasi-Peak and Average measurements were performed on the EUT:
2. Final Test Level = Receiver Reading + LISN Factor + Cable Loss.

6.3 Conducted Peak Output Power

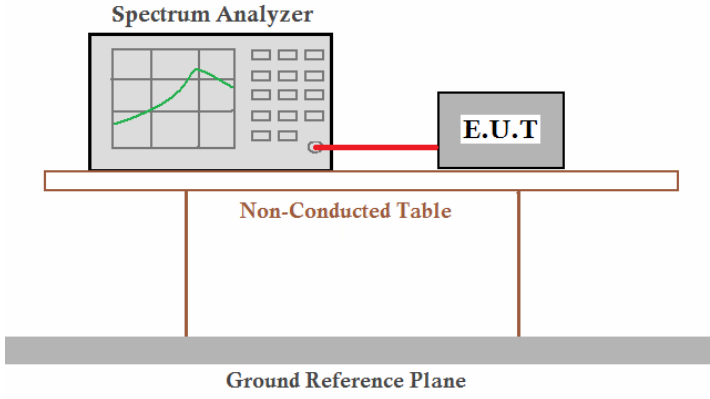
Test Requirement:	FCC Part15 C Section 15.247 (b)(3)
Test Method:	ANSI C63.4:2003 and KDB DA00-705
Receiver setup:	RBW=3MHz, VBW=3MHz, Detector=Peak
Limit:	21dBm
Test setup:	 <p>The diagram illustrates the test setup. A Spectrum Analyzer is connected to an E.U.T. (Equipment Under Test) via a red cable. Both are placed on a Non-Conducted Table, which is supported by a Ground Reference Plane.</p>
Test Instruments:	Refer to section 5.7 for details
Test mode:	Refer to section 5.3 for details
Test results:	Passed

Measurement Data

GFSK mode			
Test channel	Peak Output Power (dBm)	Limit (dBm)	Result
Lowest	4.58	21.00	Pass
Middle	5.16	21.00	Pass
Highest	5.46	21.00	Pass
Pi/4QPSK mode			
Test channel	Peak Output Power (dBm)	Limit (dBm)	Result
Lowest	3.74	21.00	Pass
Middle	4.56	21.00	Pass
Highest	4.31	21.00	Pass
8DPSK mode			
Test channel	Peak Output Power (dBm)	Limit (dBm)	Result
Lowest	4.06	21.00	Pass
Middle	4.89	21.00	Pass
Highest	4.74	21.00	Pass

Test plot as follows:

Test mode:	GFSK	Test channel:	Lowest
------------	------	---------------	--------

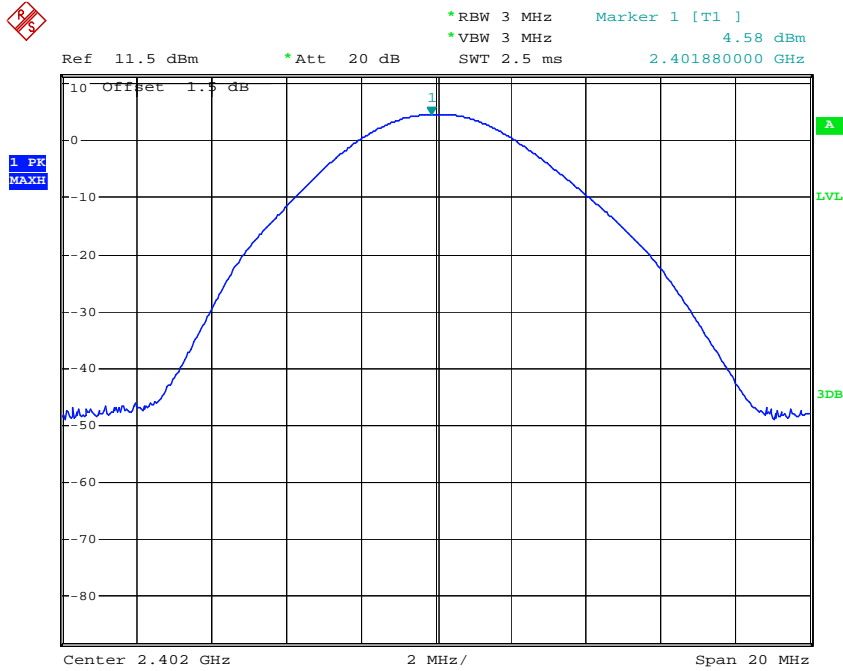

Test mode:	GFSK	Test channel:	Middle
------------	------	---------------	--------

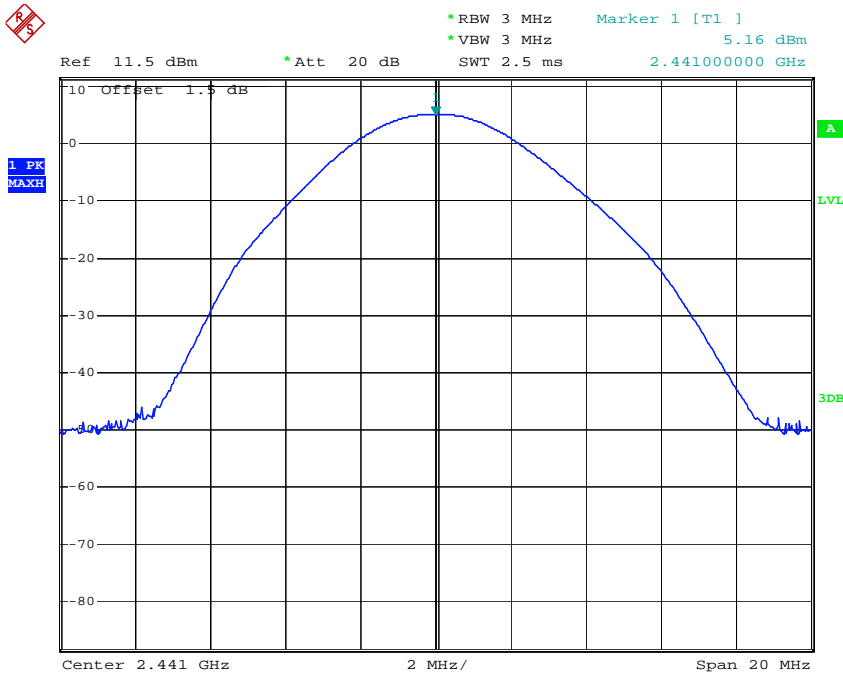

Test mode:	GFSK	Test channel:	Highest
------------	------	---------------	---------

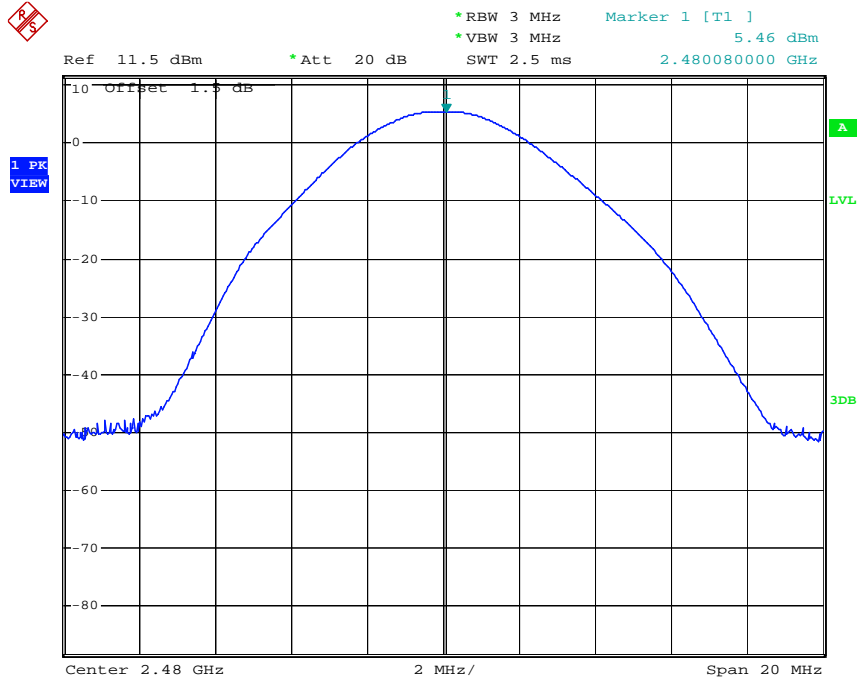

Test mode:	Pi/4QPSK	Test channel:	Lowest
------------	----------	---------------	--------

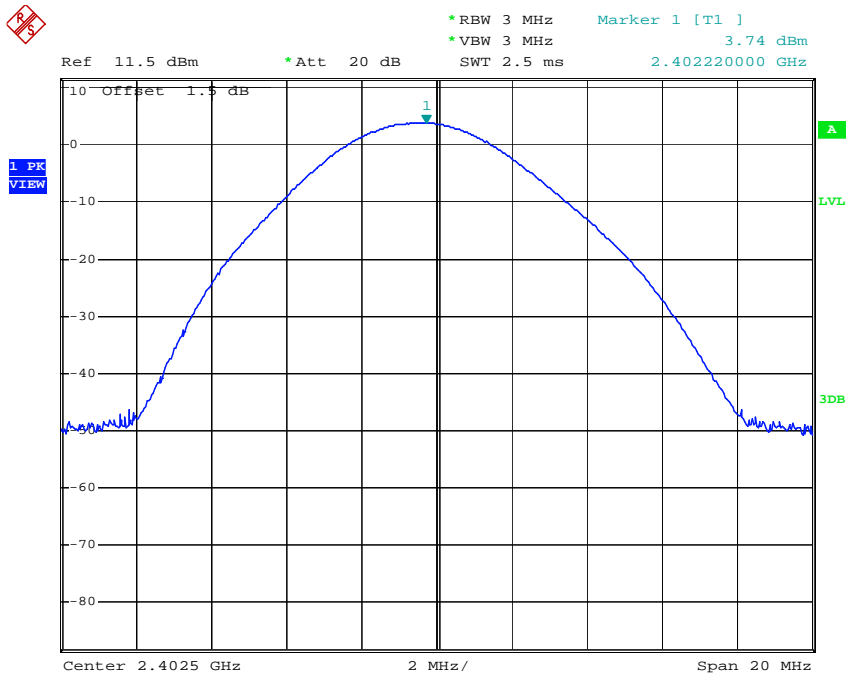

Test mode:	Pi/4QPSK	Test channel:	Middle
------------	----------	---------------	--------

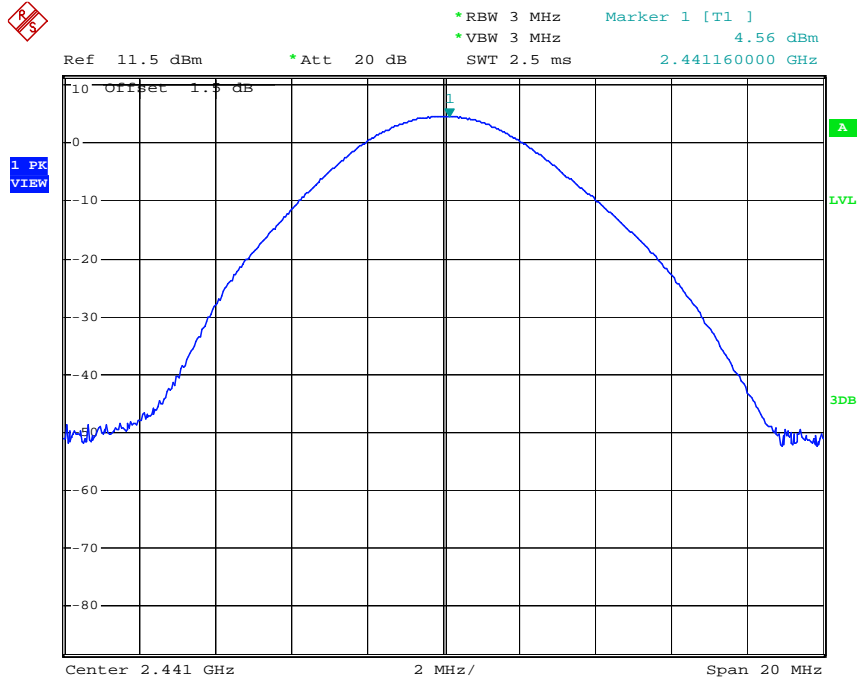

Test mode:	Pi/4QPSK	Test channel:	Highest
------------	----------	---------------	---------

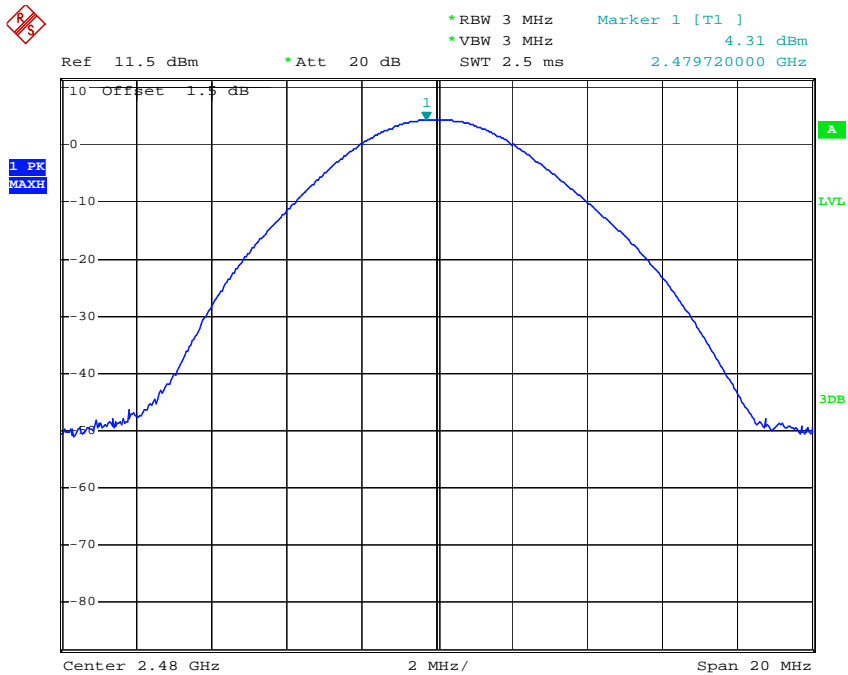

Test mode:	8DPSK	Test channel:	Lowest
------------	-------	---------------	--------

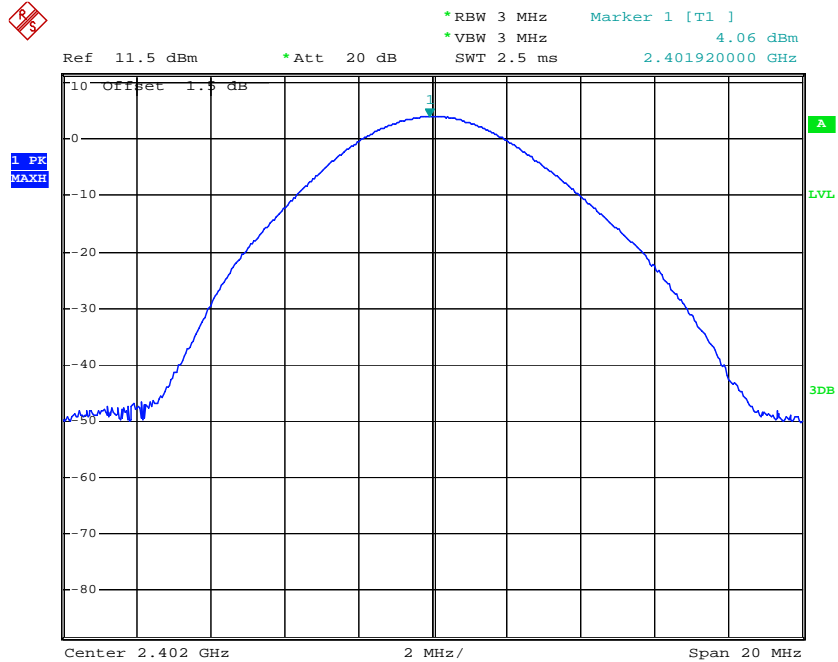

Test mode:	8DPSK	Test channel:	Middle
------------	-------	---------------	--------

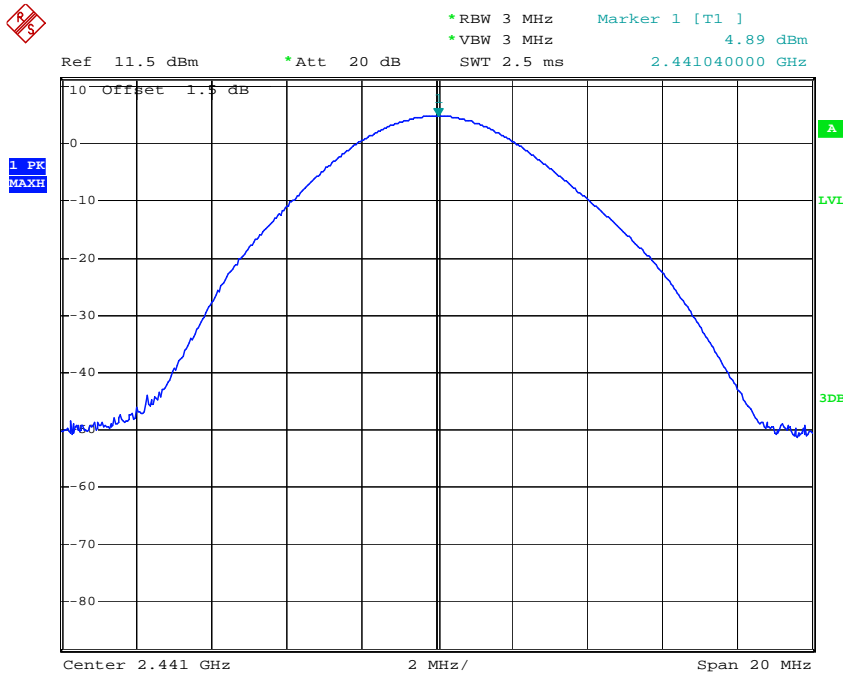

Test mode:	8DPSK	Test channel:	Highest
------------	-------	---------------	---------

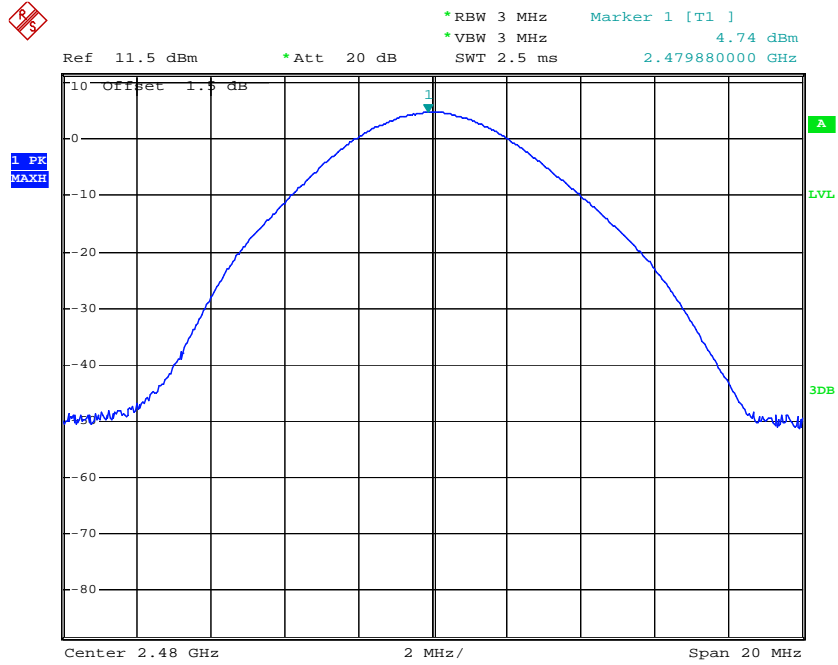

6.4 20dB Occupy Bandwidth

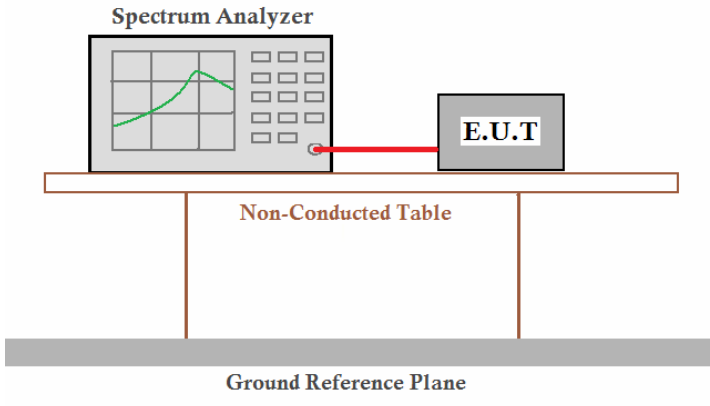
Test Requirement:	FCC Part15 C Section 15.247 (a)(1)
Test Method:	ANSI C63.4:2003 and KDB DA00-705
Receiver setup:	RBW=30KHz, VBW=100KHz,detector=Peak
Limit:	NA
Test setup:	 <p>The diagram illustrates the test setup. A Spectrum Analyzer is connected to an E.U.T. (Equipment Under Test) via a red cable. Both are placed on a Non-Conducted Table, which is supported by a Ground Reference Plane.</p>
Test Instruments:	Refer to section 5.7 for details
Test mode:	Refer to section 5.3 for details
Test results:	Passed

Measurement Data			
Test channel	20dB Occupy Bandwidth (KHz)		
	GFSK	Pi/4QPSK	8DPSK
Lowest	796	1200	1204
Middle	800	1216	1208
Highest	788	1216	1204

Test plot as follows:

Test mode:	GFSK	Test channel:	Lowest
------------	------	---------------	--------

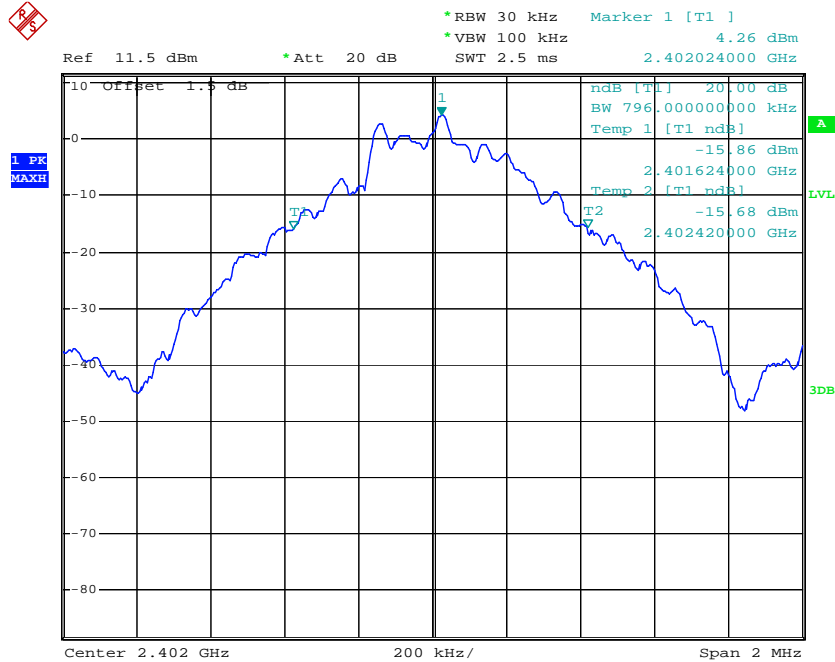

Test mode:	GFSK	Test channel:	Middle
------------	------	---------------	--------

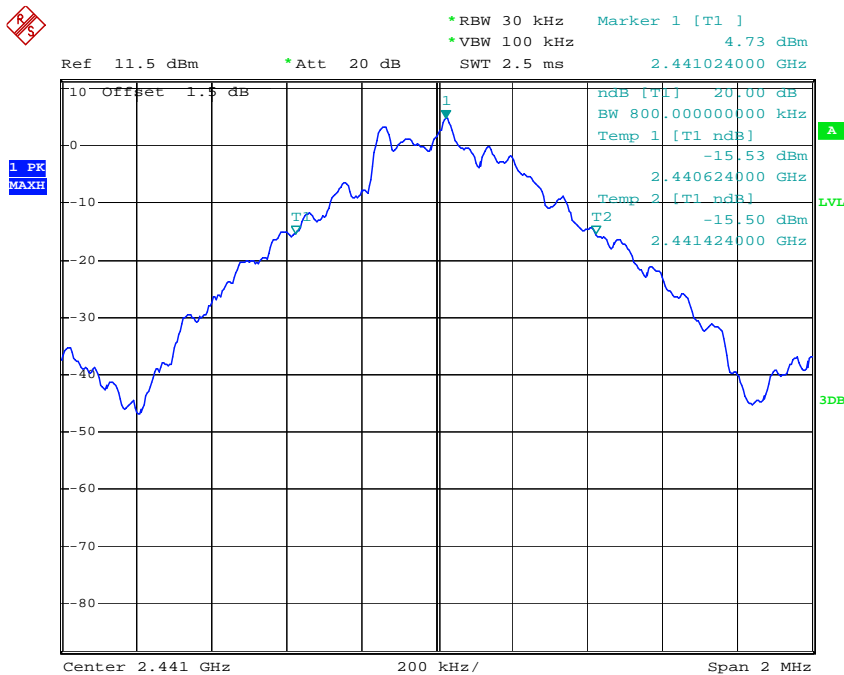

Test mode:	GFSK	Test channel:	Highest
------------	------	---------------	---------

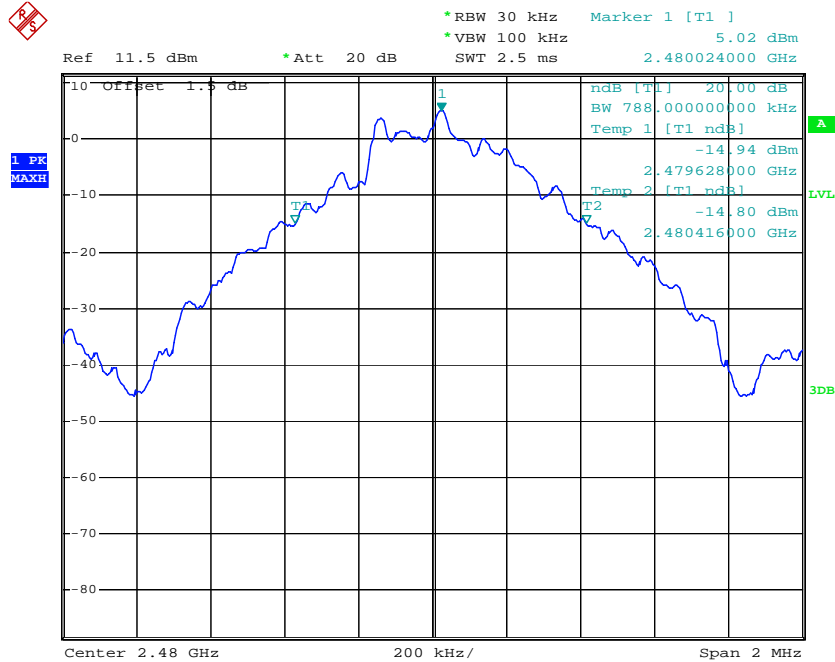

Test mode:	Pi/4QPSK	Test channel:	Lowest
------------	----------	---------------	--------

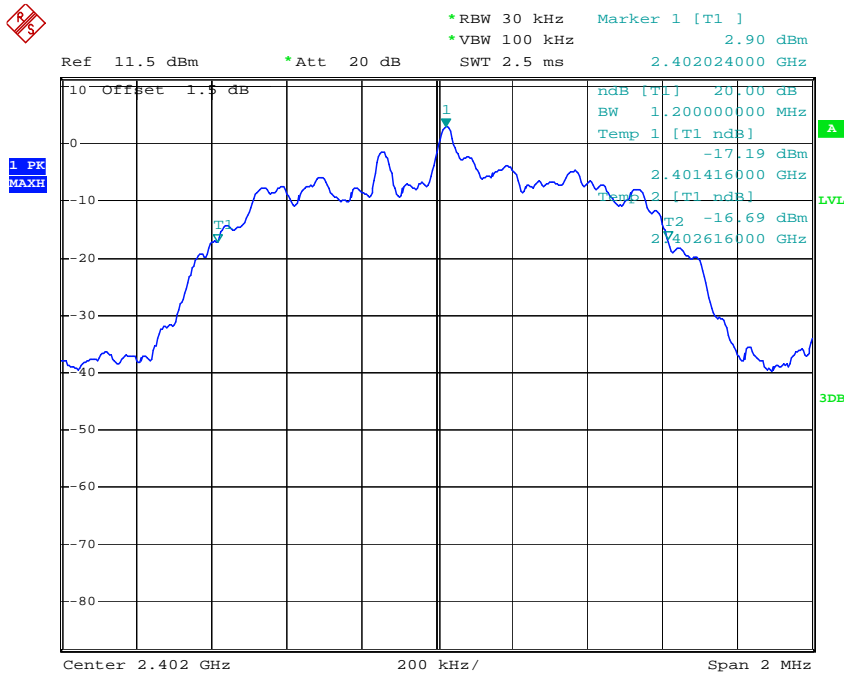

Test mode:	Pi/4QPSK	Test channel:	Middle
------------	----------	---------------	--------

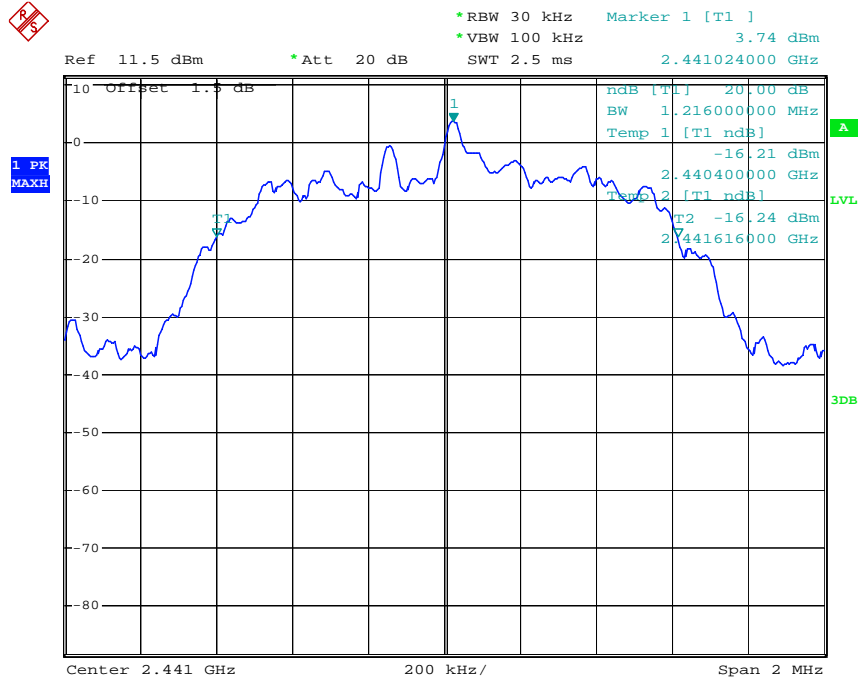

Test mode:	Pi/4QPSK	Test channel:	Highest
------------	----------	---------------	---------

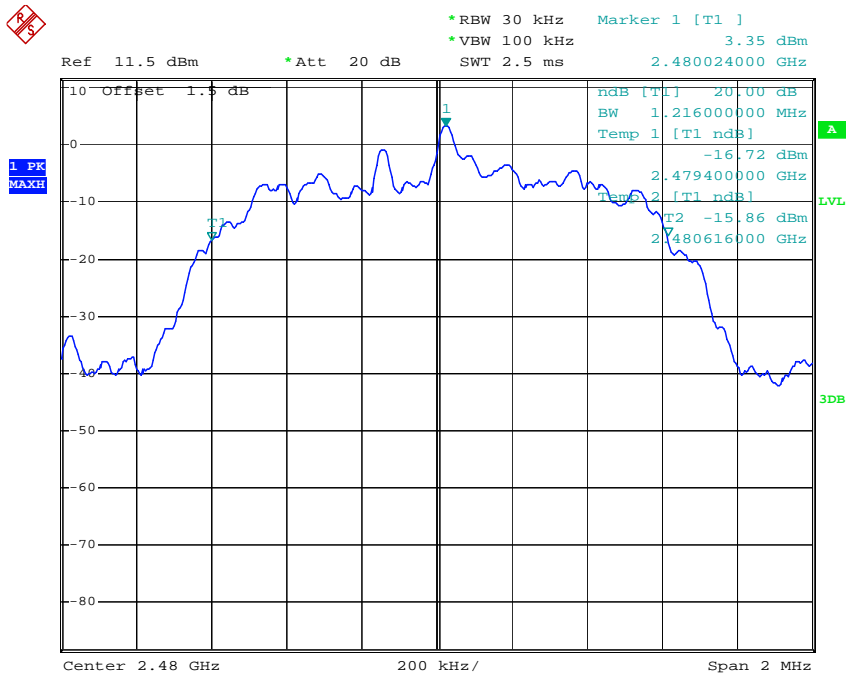

Test mode:	8DPSK	Test channel:	Lowest
------------	-------	---------------	--------

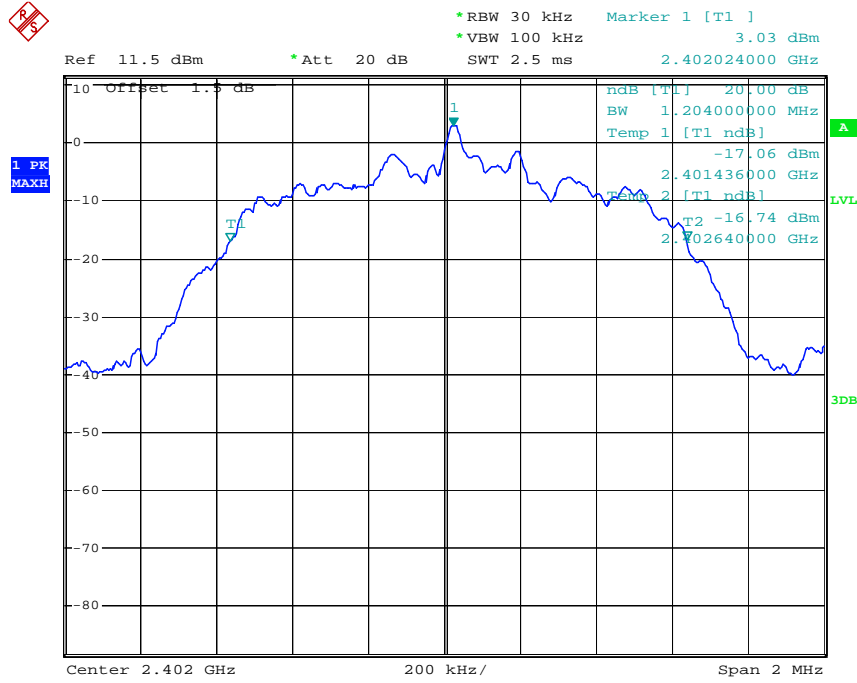

Test mode:	8DPSK	Test channel:	Middle
------------	-------	---------------	--------

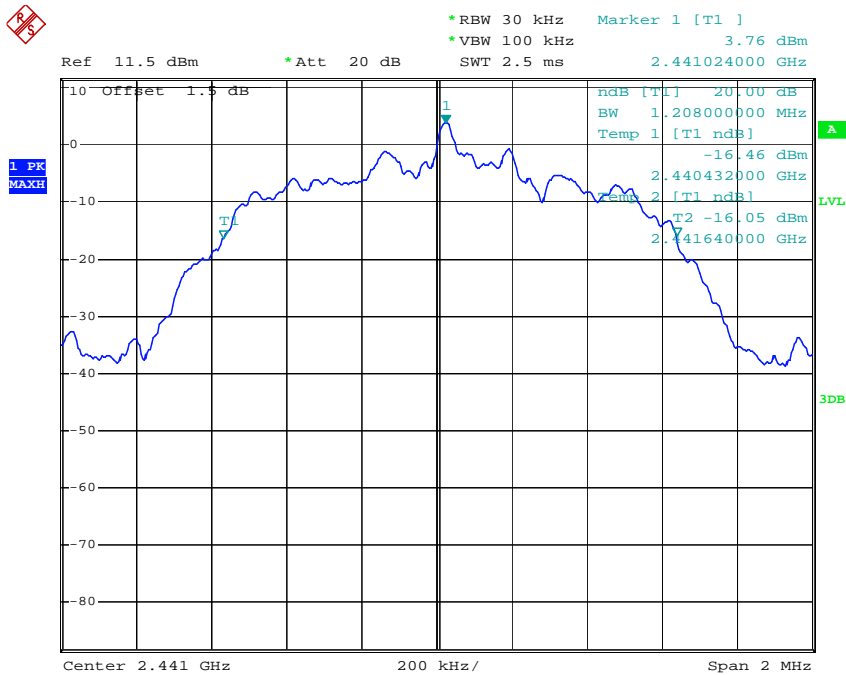

Test mode:	8DPSK	Test channel:	Highest
------------	-------	---------------	---------

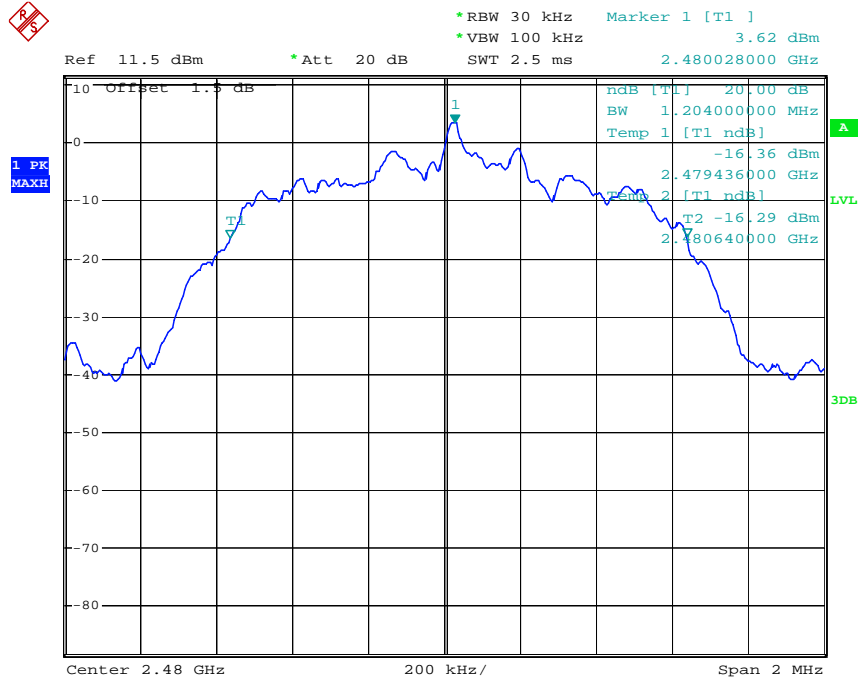

6.5 Carrier Frequencies Separation

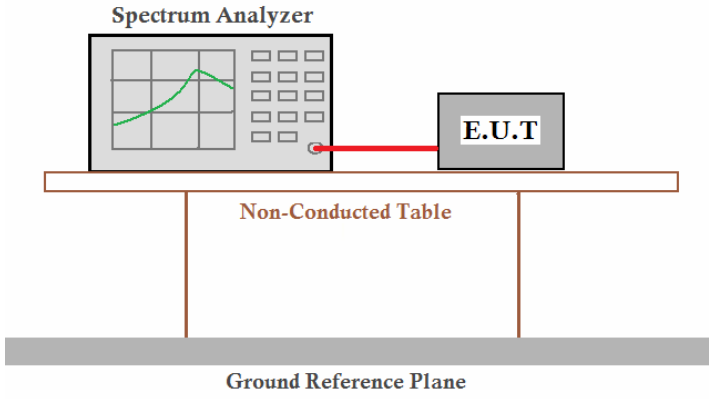
Test Requirement:	FCC Part15 C Section 15.247 (a)(1)
Test Method:	ANSI C63.4:2003 and KDB DA00-705
Receiver setup:	RBW=100KHz, VBW=300KHz, detector=Peak
Limit:	0.025MHz or 2/3 of the 20dB bandwidth (whichever is greater)
Test setup:	 <p>The diagram illustrates the test setup. A Spectrum Analyzer is connected to an E.U.T. (Equipment Under Test) via a red cable. Both are placed on a Non-Conducted Table, which is supported by a Ground Reference Plane.</p>
Test Instruments:	Refer to section 5.7 for details
Test mode:	Refer to section 5.3 for details
Test results:	Passed

Measurement Data			
GFSK mode			
Test channel	Carrier Frequencies Separation (KHz)	Limit (KHz)	Result
Lowest	1000	811	Pass
Middle	1004	811	Pass
Highest	1004	811	Pass
Pi/4QPSK mode			
Test channel	Carrier Frequencies Separation (KHz)	Limit (KHz)	Result
Lowest	1000	811	Pass
Middle	1004	811	Pass
Highest	1004	811	Pass
8DPSK mode			
Test channel	Carrier Frequencies Separation (KHz)	Limit (KHz)	Result
Lowest	1004	811	Pass
Middle	1004	811	Pass
Highest	1000	811	Pass

Note: According to section 6.4,

Mode	20dB bandwidth (KHz) (worse case)	Limit (KHz) (Carrier Frequencies Separation)
GFSK	800	533
PI/4QPSK	1216	811
8DPSK	1208	805

Test plot as follows:

Test mode:	GFSK	Test channel:	Lowest
------------	------	---------------	--------

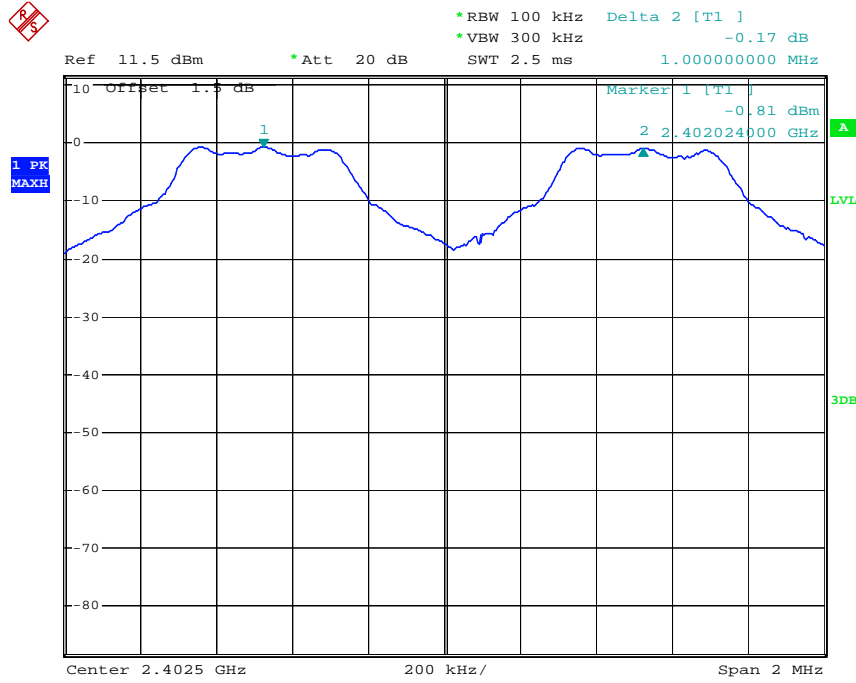

Test mode:	GFSK	Test channel:	Middle
------------	------	---------------	--------

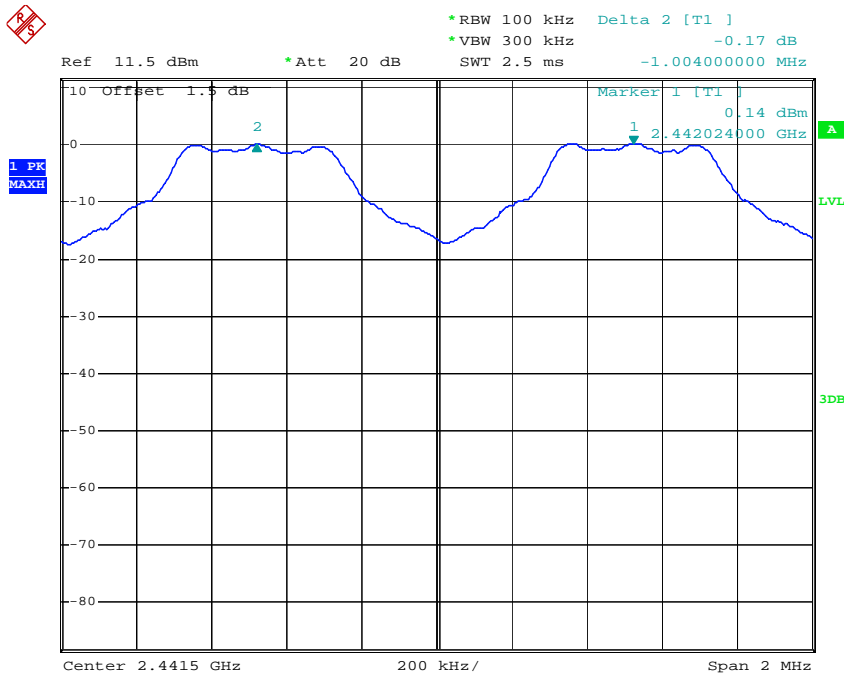

Test mode:	GFSK	Test channel:	Highest
------------	------	---------------	---------

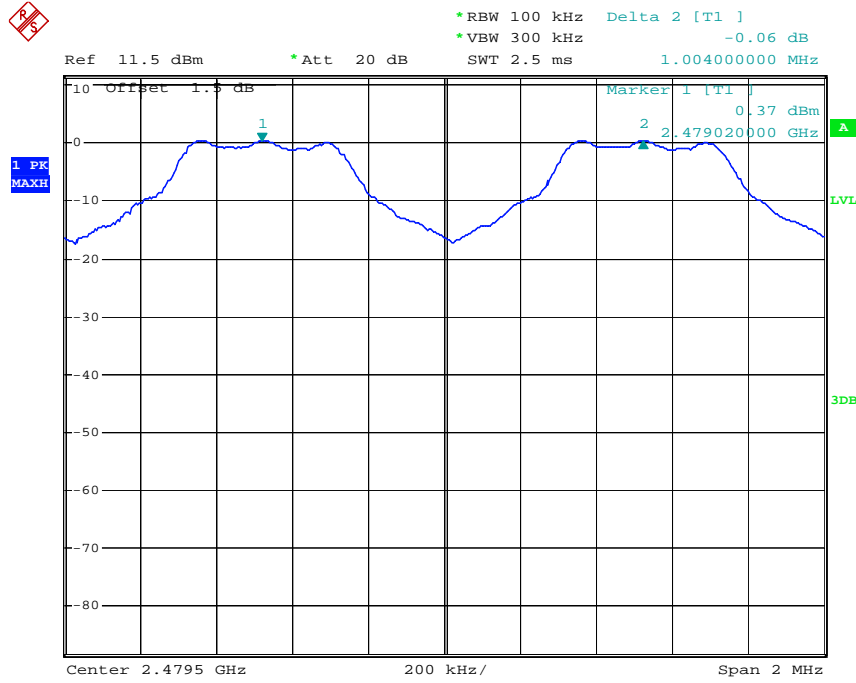

Test mode:	Pi/4QPSK	Test channel:	Lowest
------------	----------	---------------	--------

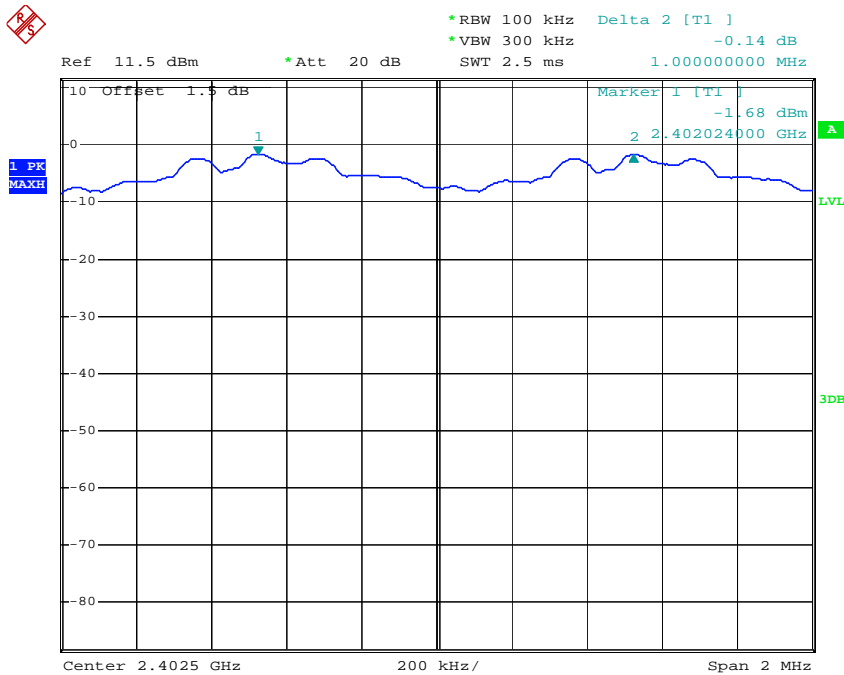

Test mode:	Pi/4QPSK	Test channel:	Middle
------------	----------	---------------	--------

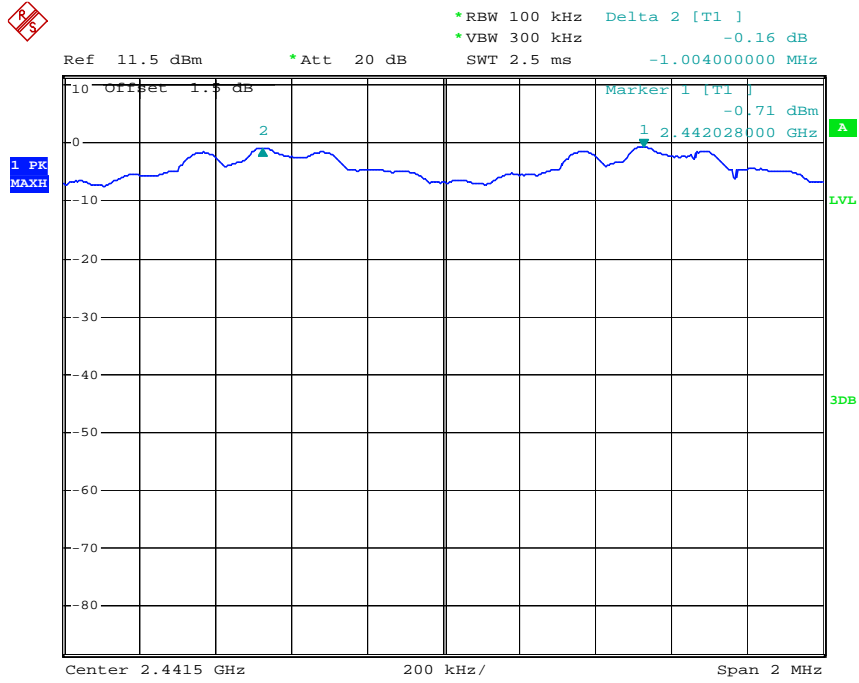

Test mode:	Pi/4QPSK	Test channel:	Highest
------------	----------	---------------	---------

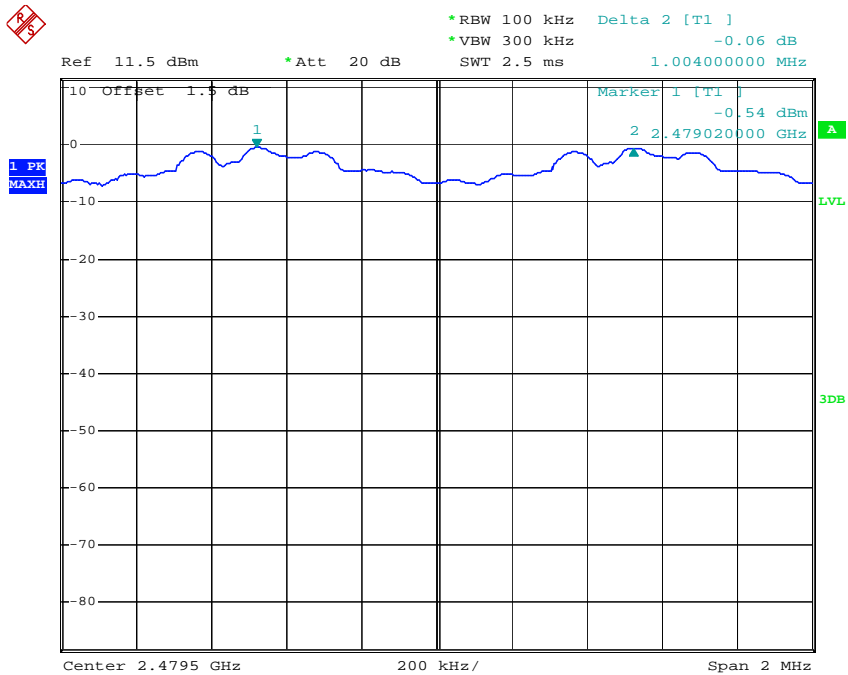

Test mode:	8DPSK	Test channel:	Lowest
------------	-------	---------------	--------

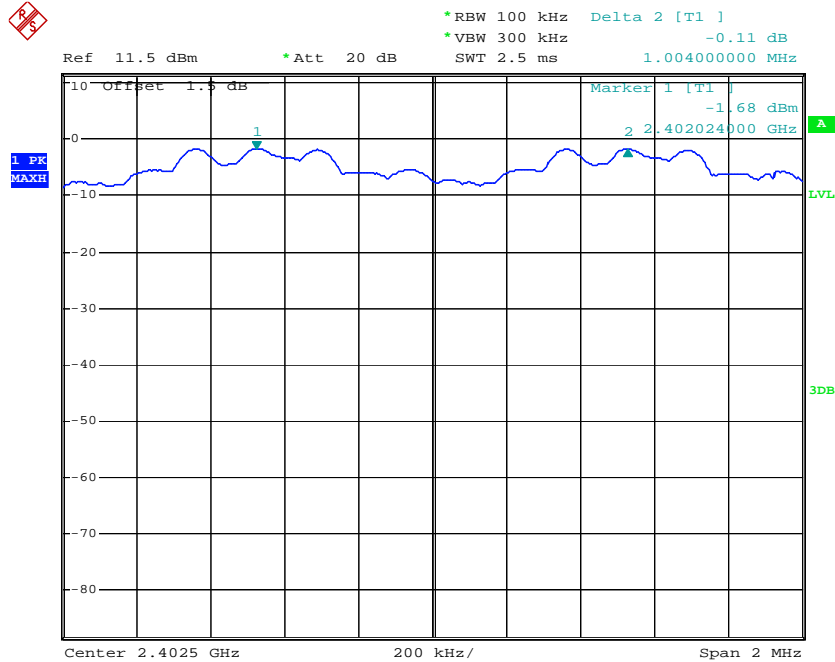

Test mode:	8DPSK	Test channel:	Middle
------------	-------	---------------	--------

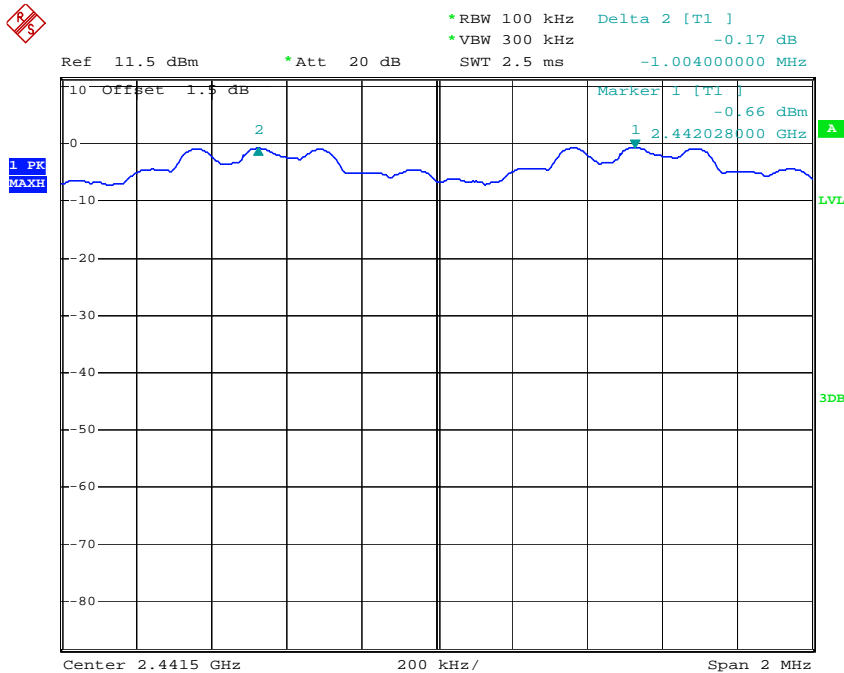

Test mode:	8DPSK	Test channel:	Highest
------------	-------	---------------	---------

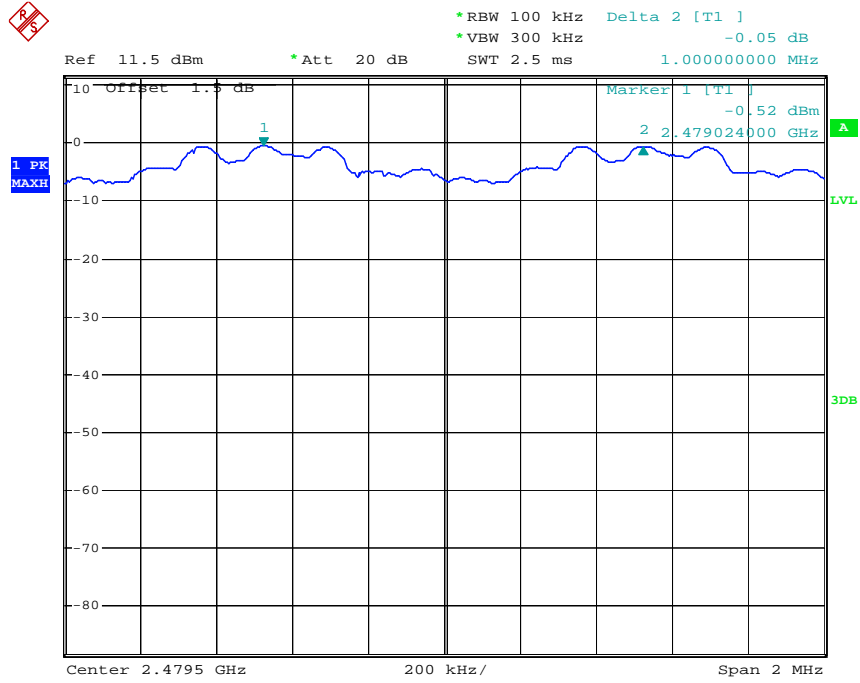

6.6 Hopping Channel Number

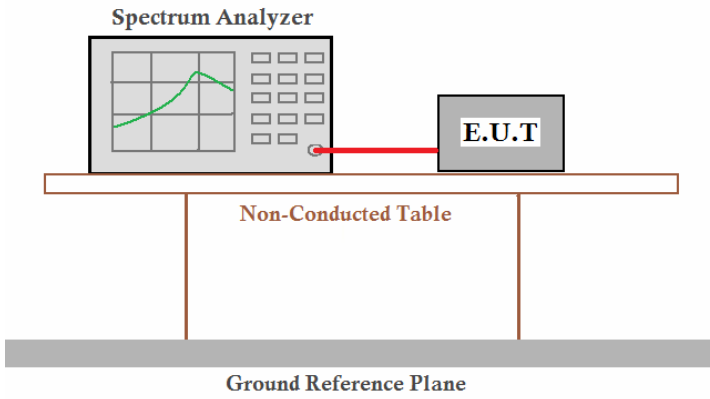
Test Requirement:	FCC Part15 C Section 15.247 (a)(1)
Test Method:	ANSI C63.4:2003 and KDB DA00-705
Receiver setup:	RBW=100KHz, VBW=300KHz, Frequency range=2400MHz-2483.5MHz, Detector=Peak
Limit:	15channels
Test setup:	 <p>The diagram illustrates the test setup. A Spectrum Analyzer is connected via a red cable to an E.U.T. (Equipment Under Test). Both are placed on a Non-Conducted Table. Below the table is a Ground Reference Plane.</p>
Test Instruments:	Refer to section 5.7 for details
Test mode:	Refer to section 5.3 for details
Test results:	Passed

Measurement Data		
Mode	Hopping channel numbers	Limit
GFSK	79	15
Pi/4QPSK	79	15
8DPSK	79	15

Test plot as follows

Test mode: GFSK

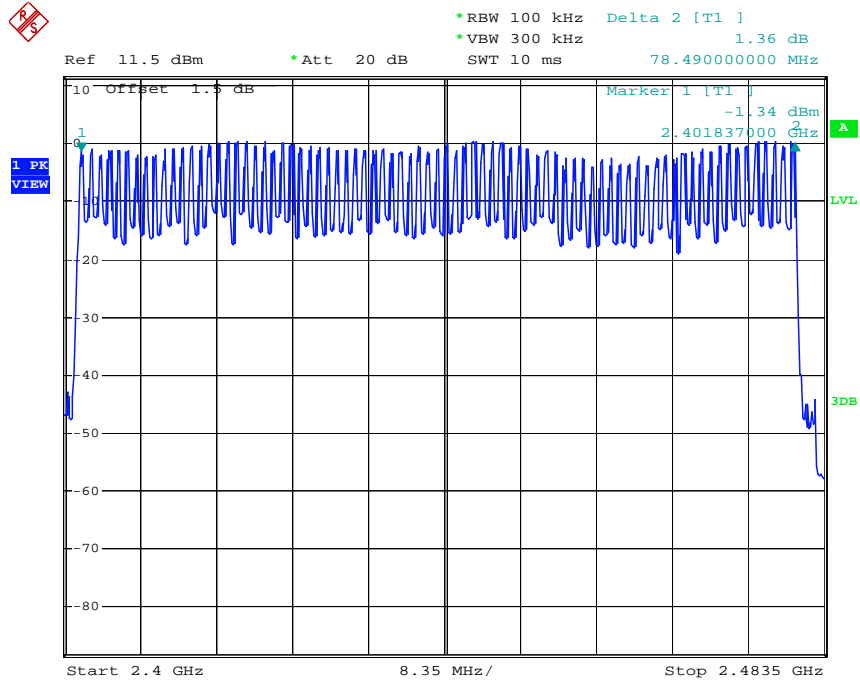

Test mode: Pi/4QPSK

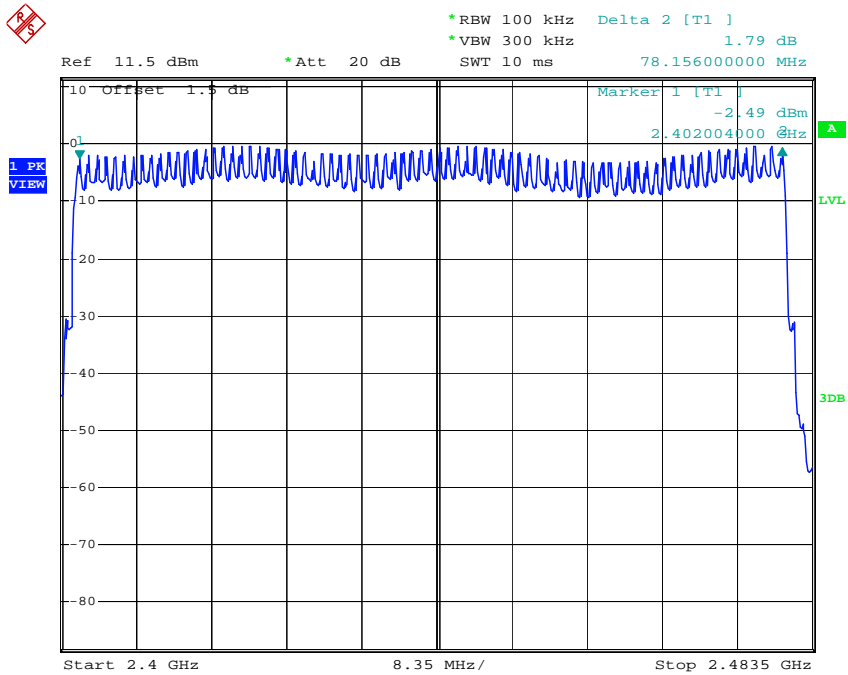

Test mode:	8DPSK	
------------	-------	--

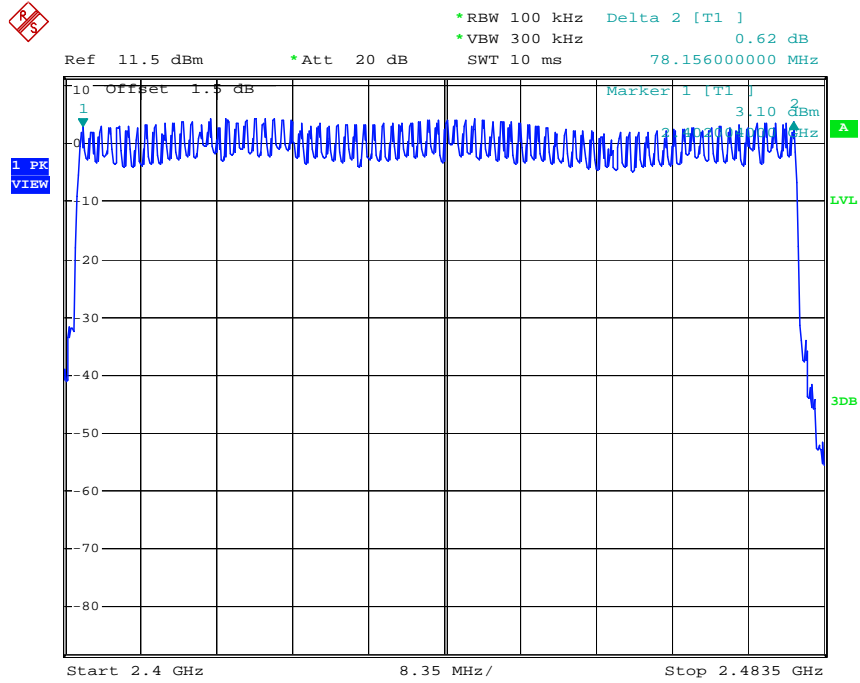

6.7 Dwell Time

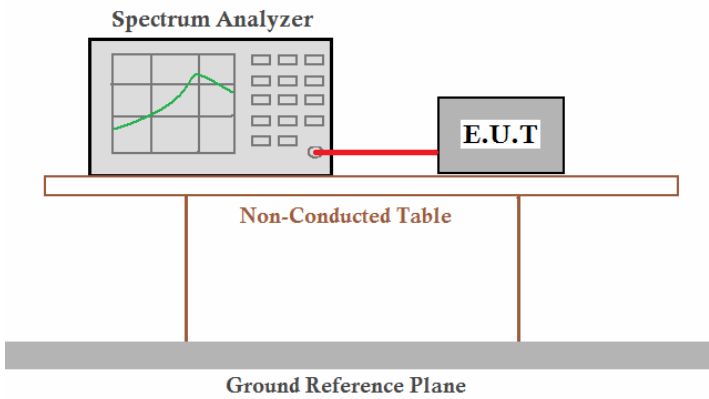
Test Requirement:	FCC Part15 C Section 15.247 (a)(1)
Test Method:	ANSI C63.4:2003 and KDB DA00-705
Receiver setup:	RBW=1MHz, VBW=1MHz, Span=0Hz, Detector=Peak
Limit:	0.4 Second
Test mode:	Hopping transmitting with all kind of modulation.
Test setup:	 <p>The diagram illustrates the test setup. A Spectrum Analyzer is connected via a red cable to an E.U.T. (Equipment Under Test). Both are placed on a Non-Conducted Table. Below the table is a Ground Reference Plane.</p>
Test Instruments:	Refer to section 5.7 for details
Test mode:	Refer to section 5.3 for details
Test results:	Passed

Measurement Data			
Mode	Packet	Dwell time (second)	Limit (second)
GFSK	DH1	0.170	0.4
	DH3	0.288	0.4
	DH5	0.324	0.4
Pi/4QPSK	2-DH1	0.170	0.4
	2-DH3	0.288	0.4
	2-DH5	0.324	0.4
8DPSK	3-DH1	0.170	0.4
	3-DH3	0.288	0.4
	3-DH5	0.324	0.4

The test period: $T = 0.4 \text{ Second/Channel} \times 79 \text{ Channel} = 31.6 \text{ s}$

The lowest channel (2402MHz), middle channel (2441MHz), highest channel (2480MHz) as blow

$$\text{DH1 time slot} = \text{Pulse time} \times (1600 / (2 \times 79)) \times 31.6$$

$$\text{DH3 time slot} = \text{Pulse time} \times (1600 / (4 \times 79)) \times 31.6$$

$$\text{DH5 time slot} = \text{Pulse time} \times (1600 / (6 \times 79)) \times 31.6$$

Test plot as follows

Test mode:	GFSK, Pi/4QPSK, 8DPSK	Test Packet:	DH1/2DH1/3DH1
------------	-----------------------	--------------	---------------

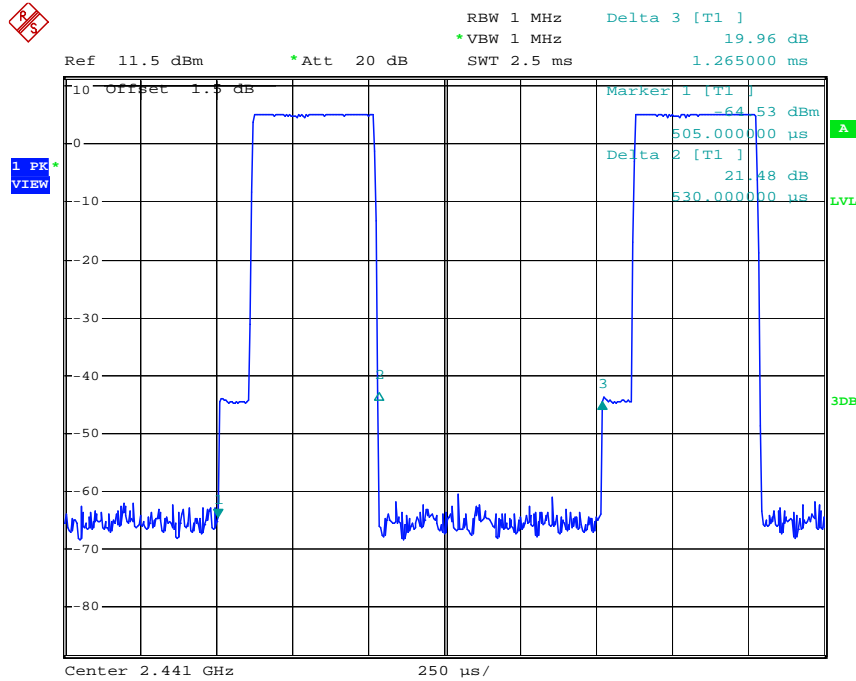

Test mode:	GFSK, Pi/4QPSK, 8DPSK	Test Packet:	DH3/2DH3/3DH3
------------	-----------------------	--------------	---------------

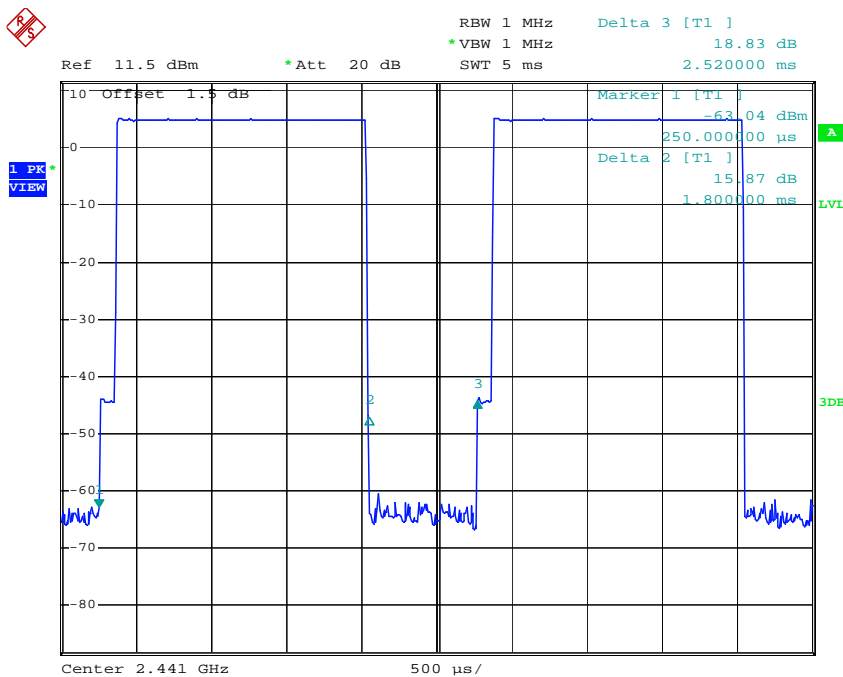

Test mode:	GFSK, Pi/4QPSK, 8DPSK	Test Packet:	DH5/2DH5/3DH5
------------	-----------------------	--------------	---------------

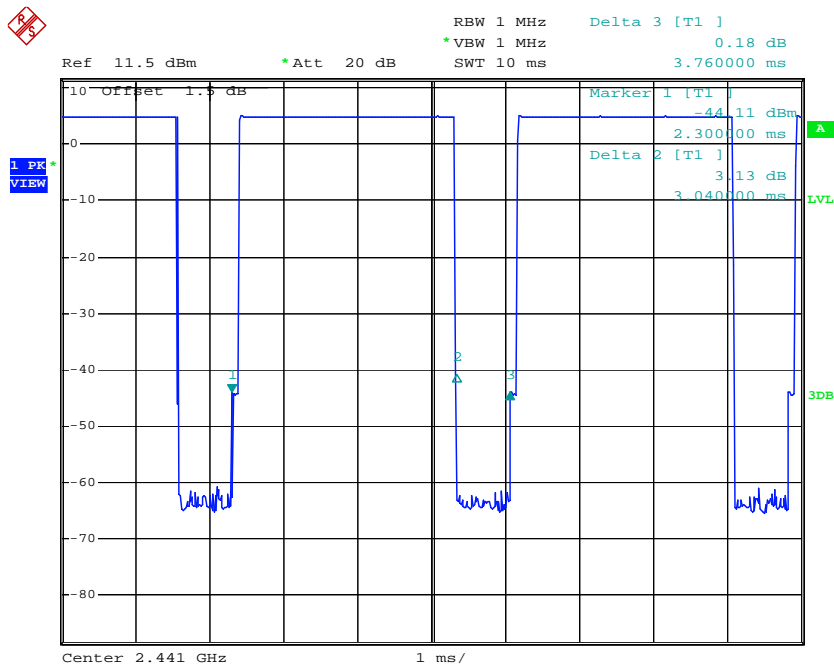

6.8 Band Edge

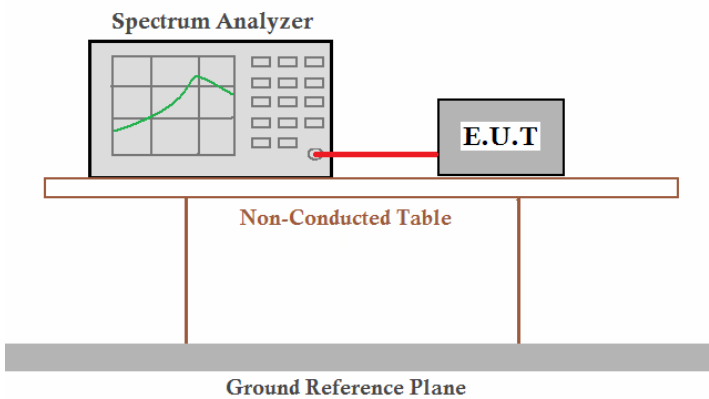
Test Requirement:	FCC Part15 C Section 15.247 (d)
Test Method:	ANSI C63.4:2003 and KDB DA00-705
Receiver setup:	RBW=100KHz, VBW=300KHz, Detector=Peak
Limit:	In any 100 kHz bandwidth outside the frequency band in which the spread spectrum intentional radiator is operating, the radio frequency power that is produced by the intentional radiator shall be at least 20 dB below that in the 100 kHz bandwidth within the band that contains the highest level of the desired power, based on either an RF conducted or a radiated measurement.
Test setup:	 <p style="text-align: center;"><i>Remark:</i> <i>Offset the High-Frequency cable loss 1.5dB in the spectrum analyzer.</i></p>
Test Instruments:	Refer to section 5.7 for details
Test mode:	Refer to section 5.3 for details
Test results:	Passed

Remark:

During test the item, Pre-scan the GFSK, Pi/4QPSK, 8DPSK modulation, and found the GFSK modulation which it is worse case.

Test plot as follows:

Worse case mode:	GFSK	Test channel:	Lowest
------------------	------	---------------	--------

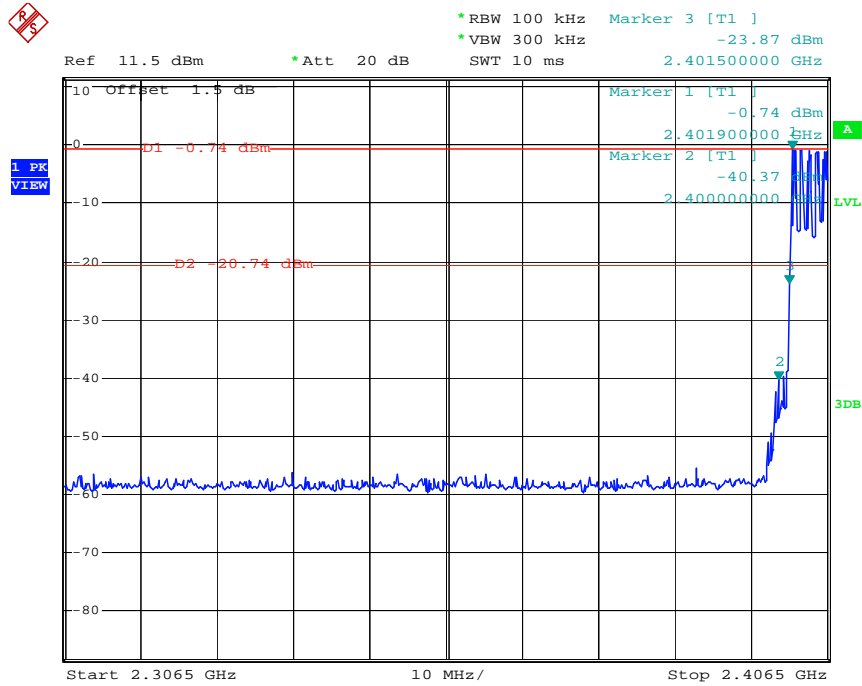

Worse case mode:	GFSK	Test channel:	Highest
------------------	------	---------------	---------

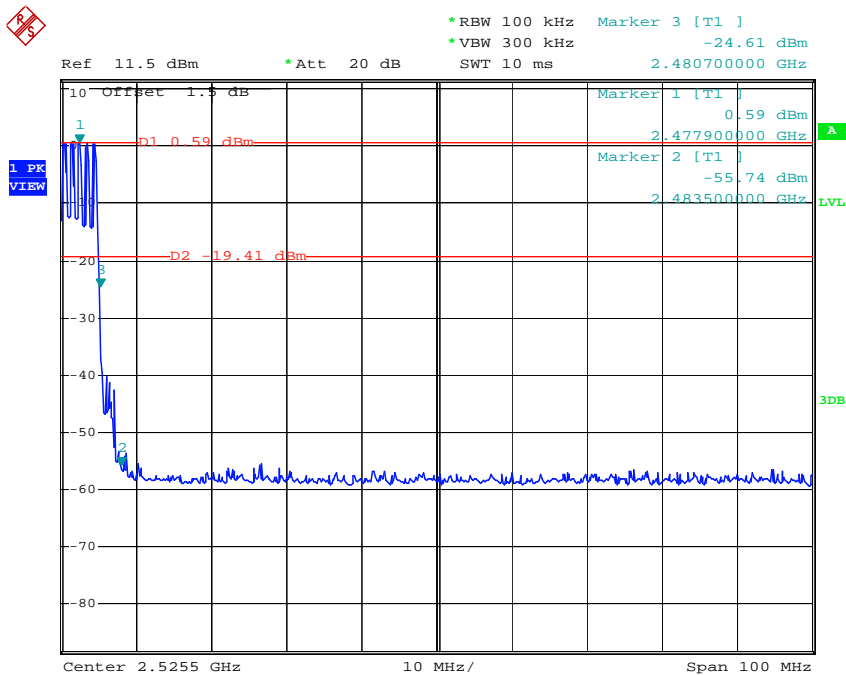

6.9 RF Antenna Conducted spurious emissions

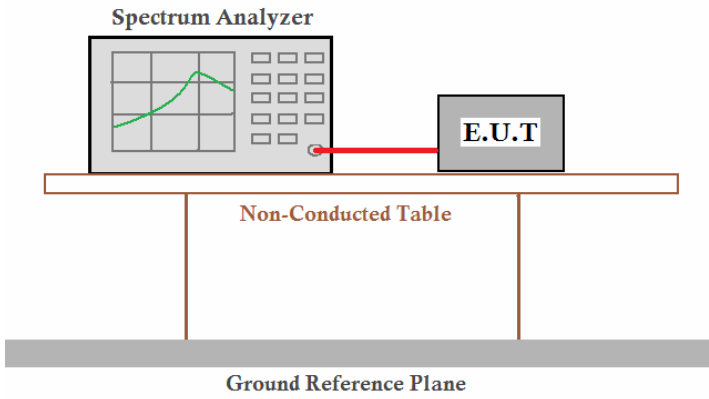
Test Requirement:	FCC Part15 C Section 15.247 (d)
Test Method:	ANSI C63.4:2003 and KDB DA00-705
Limit:	In any 100 kHz bandwidth outside the frequency band in which the spread spectrum intentional radiator is operating, the radio frequency power that is produced by the intentional radiator shall be at least 20 dB below that in the 100 kHz bandwidth within the band that contains the highest level of the desired power, based on either an RF conducted or a radiated measurement.
Test setup:	 <p><i>Remark: Offset the High-Frequency cable loss 1.5dB in the spectrum analyzer.</i></p>
Test Instruments:	Refer to section 5.7 for details
Test mode:	Refer to section 5.3 for details
Test results:	Passed

Remark:

During test the item, Pre-scan the GFSK, Pi/4QPSK, 8DPSK modulation, and found the GFSK modulation which it is worse case.

Worse case mode:	GFSK	Test channel:	Lowest
------------------	------	---------------	--------

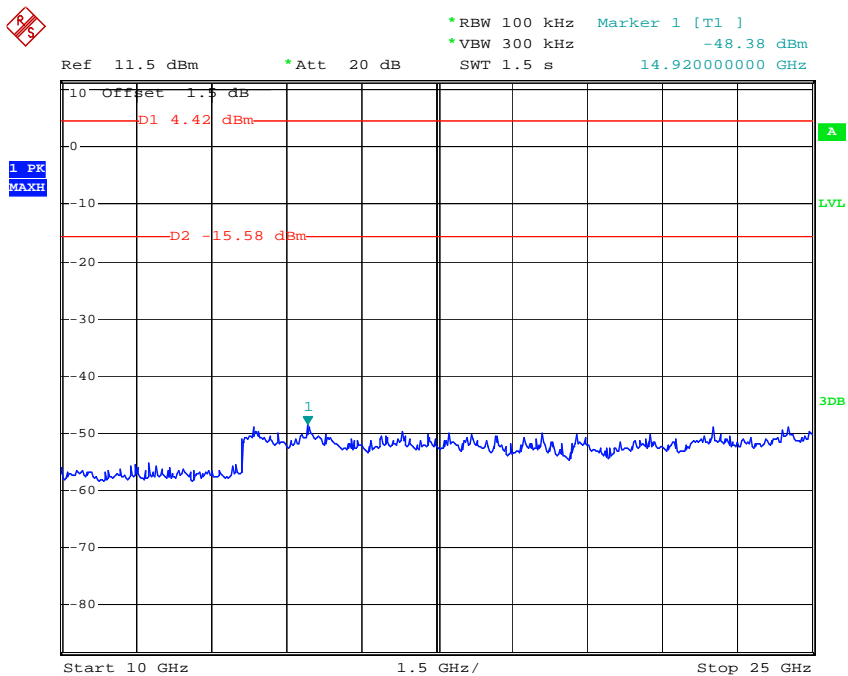
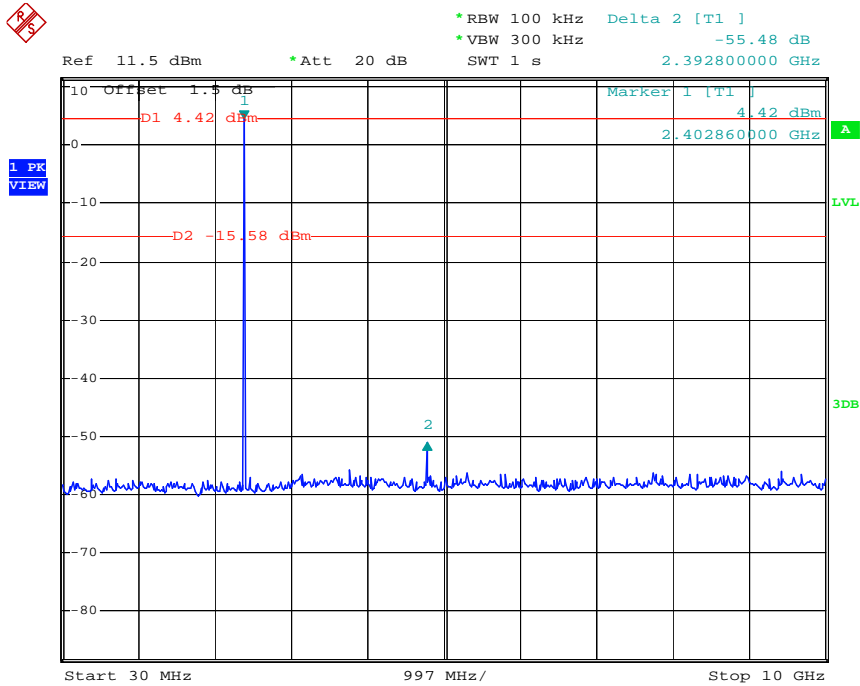

Worse case mode:	GFSK	Test channel:	Middle
------------------	------	---------------	--------

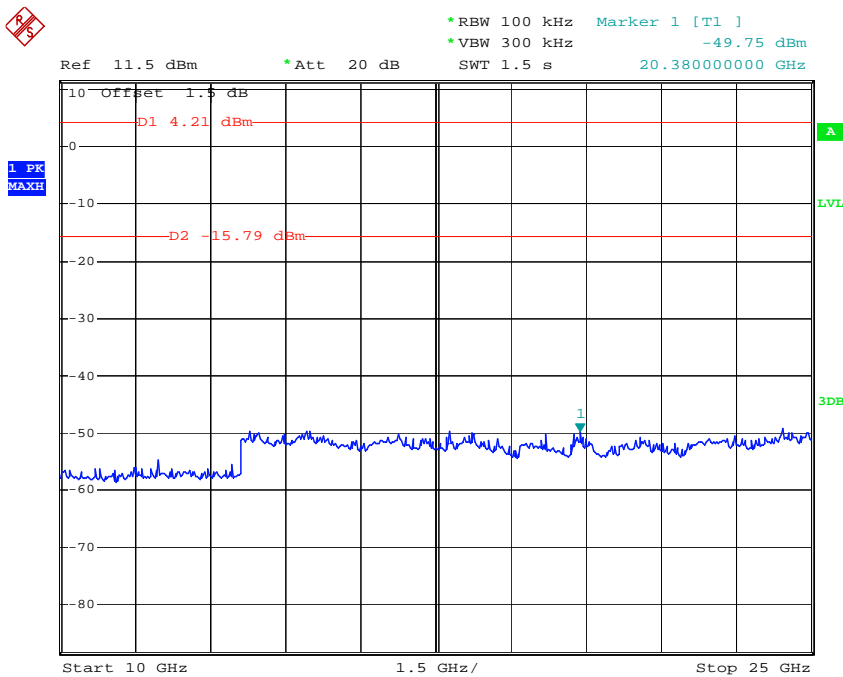
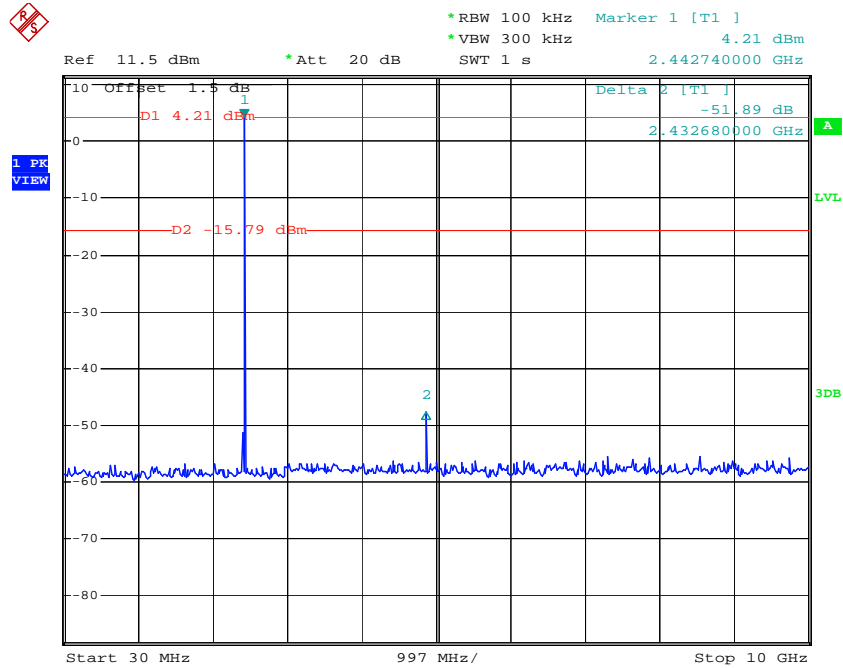

Worse case mode:	GFSK	Test channel:	Highest
------------------	------	---------------	---------

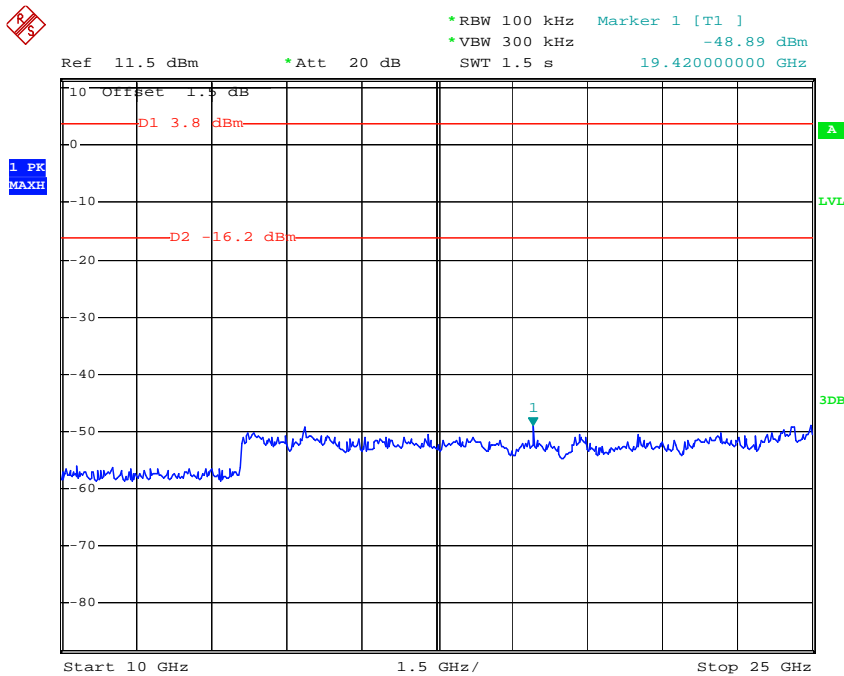
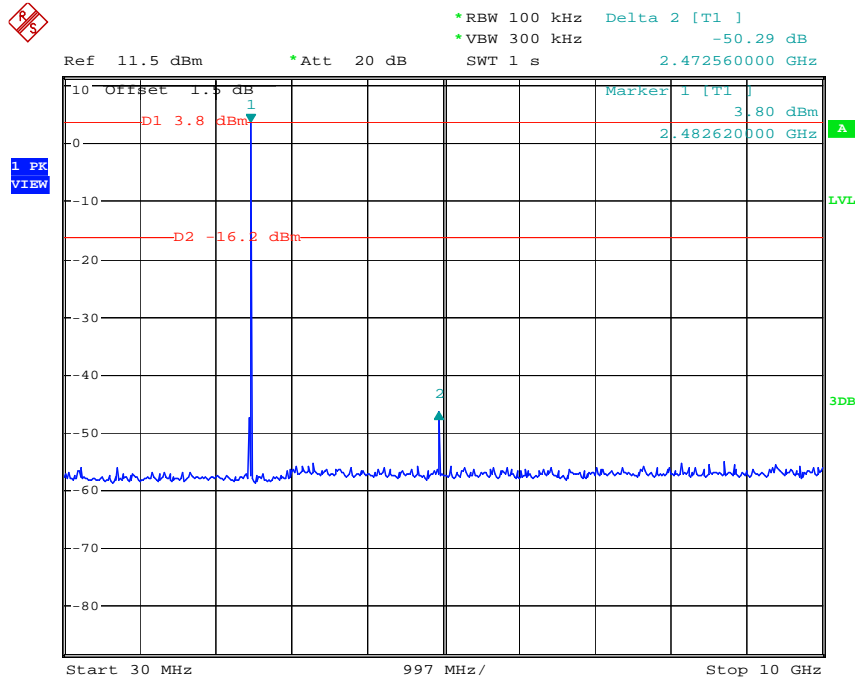

6.10 Pseudorandom Frequency Hopping Sequence

Test Requirement:	FCC Part15 C Section 15.247 (a)(1) requirement:
<p>Frequency hopping systems shall have hopping channel carrier frequencies separated by a minimum of 25 kHz or the 20 dB bandwidth of the hopping channel, whichever is greater.</p> <p>Alternatively. Frequency hopping systems operating in the 2400-2483.5 MHz band may have hopping channel carrier frequencies that are separated by 25 kHz or two-thirds of the 20 dB bandwidth of the hopping channel, whichever is greater, provided the systems operate with an output power no greater than 125 mW. The system shall hop to channel frequencies that are selected at the system hopping rate from a Pseudorandom ordered list of hopping frequencies. Each frequency must be used equally on the average by each transmitter. The system receivers shall have input bandwidths that match the hopping channel bandwidths of their corresponding transmitters and shall shift frequencies in synchronization with the transmitted signals.</p>	
EUT Pseudorandom Frequency Hopping Sequence	
<p>The pseudorandom sequence may be generated in a nine-stage shift register whose 5th and 9th stage outputs are added in a modulo-two addition stage. And the result is fed back to the input of the first stage. The sequence begins with the first ONE of 9 consecutive ONES; i.e. the shift register is initialized with nine ones.</p> <ul style="list-style-type: none"> • Number of shift register stages: 9 • Length of pseudo-random sequence: $2^9 - 1 = 511$ bits • Longest sequence of zeros: 8 (non-inverted signal) <div data-bbox="272 1066 1326 1211" style="text-align: center;"> </div> <p style="text-align: center;"><i>Linear Feedback Shift Register for Generation of the PRBS sequence</i></p> <p>An example of Pseudorandom Frequency Hopping Sequence as follow:</p> <div data-bbox="248 1317 1243 1464" style="text-align: center;"> </div> <p>Each frequency used equally on the average by each transmitter. The system receivers have input bandwidths that match the hopping channel bandwidths of their corresponding transmitters and shift frequencies in synchronization with the transmitted signals.</p>	

6.11 Radiated Emission

Test Requirement:	FCC Part15 C Section 15.209 and 15.205				
Test Method:	ANSI C63.4: 2003				
Test Frequency Range:	30MHz to 25GHz				
Test site:	Measurement Distance: 3m (Semi-Anechoic Chamber)				
Receiver setup:					
	Frequency	Detector	RBW	VBW	Remark
	30MHz-1GHz	Quasi-peak	100KHz	300KHz	Quasi-peak Value
	Above 1GHz	Peak	1MHz	3MHz	Peak Value
Peak		1MHz	10Hz	Average Value	
Limit:					
	Frequency		Limit (dBuV/m @3m)	Remark	
	30MHz-88MHz		40.0	Quasi-peak Value	
	88MHz-216MHz		43.5	Quasi-peak Value	
	216MHz-960MHz		46.0	Quasi-peak Value	
	960MHz-1GHz		54.0	Quasi-peak Value	
	Above 1GHz		54.0	Average Value	
			74.0	Peak Value	
Test Procedure:	<p>a. The EUT was placed on the top of a rotating table 0.8 meters above the ground at a 3 meter semi-anechoic chamber. The table was rotated 360 degrees to determine the position of the highest radiation.</p> <p>b. The EUT was set 3 meters away from the interference-receiving antenna, which was mounted on the top of a variable-height antenna tower.</p> <p>c. The antenna height is varied from one meter to four meters above the ground to determine the maximum value of the field strength. Both horizontal and vertical polarizations of the antenna are set to make the measurement.</p> <p>d. For each suspected emission, the EUT was arranged to its worst case and then the antenna was tuned to heights from 1 meter to 4 meters and the rotatable table was turned from 0 degrees to 360 degrees to find the maximum reading.</p> <p>e. The test-receiver system was set to Peak Detect Function and Specified Bandwidth with Maximum Hold Mode.</p> <p>f. If the emission level of the EUT in peak mode was 10dB lower than the limit specified, then testing could be stopped and the peak values of the EUT would be reported. Otherwise the emissions that did not have 10dB margin would be re-tested one by one using peak, quasi-peak or average method as specified and then reported in a data sheet.</p> <p>g. The radiation measurements are performed in X, Y, Z axis positioning. Only the worst case is shown in the report.</p>				

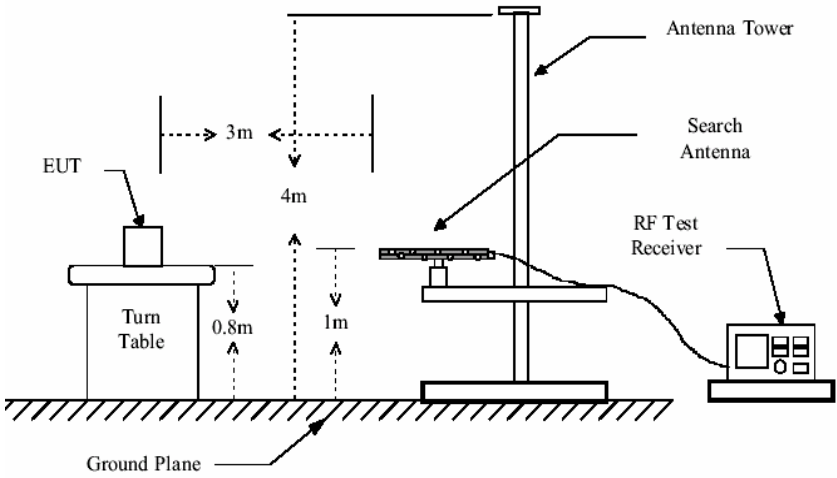
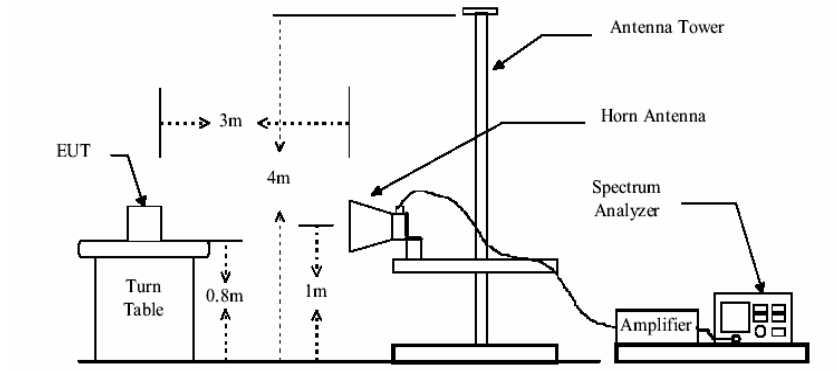
<p>Test setup:</p>	<p>Below 1GHz</p>  <p>Above 1GHz</p> 
<p>Test Instruments:</p>	<p>Refer to section 5.7 for details</p>
<p>Test mode:</p>	<p>Refer to section 5.3 for details</p>
<p>Test results:</p>	<p>Passed</p>

Note:

The field strength is calculated by adding the Antenna Factor, Cable Factor & Preamplifier. The basic equation with a sample calculation is as follows:

$$\text{Final Test Level} = \text{Receiver Reading} + \text{Antenna Factor} + \text{Cable Factor} - \text{Preamplifier Factor}$$

6.11.1 Radiated emission below 1GHz

Frequency (MHz)	Read Level (dBuV)	Antenna Factor (dB/m)	Cable Loss (dB)	Preamp Factor (dB)	Level (dBuV/m)	Limit Line (dBuV/m)	Over Limit (dB)	polarization
34.28	46.76	14.98	0.62	32.23	30.13	40.00	-9.87	Vertical
53.69	40.00	15.78	0.68	31.99	24.47	40.00	-15.53	Vertical
129.92	42.89	10.32	1.39	31.86	22.74	43.50	-20.76	Vertical
191.75	43.40	10.56	1.74	32.22	23.48	43.50	-20.02	Vertical
282.00	47.53	12.11	2.03	32.29	29.38	46.00	-16.62	Vertical
779.61	37.92	21.73	3.10	31.53	31.22	46.00	-14.78	Vertical
30.96	36.98	15.88	0.60	32.27	21.19	40.00	-18.81	Horizontal
51.48	36.10	14.98	0.68	32.01	19.75	40.00	-20.25	Horizontal
121.12	37.47	10.76	1.32	31.81	17.74	43.50	-25.76	Horizontal
207.85	53.02	10.58	1.81	32.27	33.14	43.50	-10.36	Horizontal
370.70	37.78	14.32	2.21	32.31	22.00	46.00	-24.00	Horizontal
701.76	36.75	23.19	2.94	31.69	31.19	46.00	-14.81	Horizontal

6.11.2 Transmitter emission above 1GHz

Worse case mode:		GFSK		Test channel:		Lowest		Remark:		Peak
Frequency (MHz)	Cable Loss (dB)	Antenna Factor (dB/m)	Preamp Factor (dB)	Read Level (dBuV)	Level (dBuV/m)	Limit Line (dBuV/m)	Over Limit (dB)	polarization		
2328	6.02	29.76	39.75	49.00	45.03	74.00	-28.97	Vertical		
2398	6.34	30.03	38.87	48.25	45.75	74.00	-28.25	Vertical		
2400	6.34	30.03	38.87	51.83	49.33	74.00	-24.67	Vertical		
4804	9.36	34.25	41.53	48.93	51.01	74.00	-22.99	Vertical		
7206	13.38	37.23	40.98	49.49	59.12	74.00	-14.88	Vertical		
9608	13.39	37.99	37.56	44.36	58.18	74.00	-15.82	Vertical		
12010	16.45	39.10	39.09	43.97	60.43	74.00	-13.57	Vertical		
2328	6.02	29.76	39.75	48.86	44.89	74.00	-29.11	Horizontal		
2398	6.34	30.03	38.87	48.68	46.18	74.00	-27.82	Horizontal		
2400	6.34	30.03	38.87	52.05	49.55	74.00	-24.45	Horizontal		
4804	9.36	34.25	41.53	47.78	49.86	74.00	-24.14	Horizontal		
7206	13.38	37.23	40.98	48.61	58.24	74.00	-15.76	Horizontal		
9608	13.39	37.99	37.56	43.95	57.77	74.00	-16.23	Horizontal		
12010	16.45	39.10	39.09	42.65	59.11	74.00	-14.89	Horizontal		

Worse case mode:		GFSK		Test channel:		Lowest		Remark:		Average
Frequency (MHz)	Cable Loss (dB)	Antenna Factor (dB/m)	Preamp Factor (dB)	Read Level (dBuV)	Level (dBuV/m)	Limit Line (dBuV/m)	Over Limit (dB)	polarization		
2328	6.02	29.76	39.75	36.27	32.30	54.00	-21.70	Vertical		
2398	6.34	30.03	38.87	35.83	33.33	54.00	-20.67	Vertical		
2400	6.34	30.03	38.87	39.42	36.92	54.00	-17.08	Vertical		
4804	9.36	34.25	41.53	34.60	36.68	54.00	-17.32	Vertical		
7206	13.38	37.23	40.98	34.30	43.93	54.00	-10.07	Vertical		
9608	13.39	37.99	37.56	30.81	44.63	54.00	-9.37	Vertical		
12010	16.45	39.10	39.09	29.48	45.94	54.00	-8.06	Vertical		
2328	6.02	29.76	39.75	36.45	32.48	54.00	-21.52	Horizontal		
2398	6.34	30.03	38.87	35.76	33.26	54.00	-20.74	Horizontal		
2400	6.34	30.03	38.87	39.36	36.86	54.00	-17.14	Horizontal		
4804	9.36	34.25	41.53	34.58	36.66	54.00	-17.34	Horizontal		
7206	13.38	37.23	40.98	34.37	44.00	54.00	-10.00	Horizontal		
9608	13.39	37.99	37.56	30.88	44.70	54.00	-9.30	Horizontal		
12010	16.45	39.10	39.09	29.48	45.94	54.00	-8.06	Horizontal		

Worse case mode:		GFSK		Test channel:		Middle		Remark:		Peak
Frequency (MHz)	Cable Loss (dB)	Antenna Factor (dB/m)	Preamp Factor (dB)	Read Level (dBuV)	Level (dBuV/m)	Limit Line (dBuV/m)	Over Limit (dB)	polarization		
2400	6.34	30.03	38.87	46.82	44.32	74.00	-29.68	Vertical		
2483.5	6.22	30.32	39.53	46.68	43.69	74.00	-30.31	Vertical		
4882	10.57	34.35	40.33	48.46	53.05	74.00	-20.95	Vertical		
7323	12.91	37.31	40.40	47.46	57.28	74.00	-16.72	Vertical		
9764	13.89	38.03	37.94	42.27	56.25	74.00	-17.75	Vertical		
12205	17.95	39.23	39.30	42.35	60.23	74.00	-13.77	Vertical		
2400	6.34	30.03	38.87	46.63	44.13	74.00	-29.87	Horizontal		
2483.5	6.22	30.32	39.53	50.93	47.94	74.00	-26.06	Horizontal		
4882	10.57	34.35	40.33	52.54	57.13	74.00	-16.87	Horizontal		
7323	12.91	37.31	40.40	48.22	58.04	74.00	-15.96	Horizontal		
9764	13.89	38.03	37.94	42.26	56.24	74.00	-17.76	Horizontal		
12205	17.95	39.23	39.30	42.11	59.99	74.00	-14.01	Horizontal		

Worse case mode:		GFSK		Test channel:		Middle		Remark:		Average
------------------	--	------	--	---------------	--	--------	--	---------	--	---------

Frequency (MHz)	Cable Loss (dB)	Antenna Factor (dB/m)	Preamp Factor (dB)	Read Level (dBuV)	Level (dBuV/m)	Limit Line (dBuV/m)	Over Limit (dB)	polarization	
2400	6.34	30.03	38.87	34.04	31.54	54.00	-22.46	Vertical	
2483.5	6.22	30.32	39.53	33.58	30.59	54.00	-23.41	Vertical	
4882	10.57	34.35	40.33	33.83	38.42	54.00	-15.58	Vertical	
7323	12.91	37.31	40.40	33.70	43.52	54.00	-10.48	Vertical	
9764	13.89	38.03	37.94	30.00	43.98	54.00	-10.02	Vertical	
12205	17.95	39.23	39.30	28.99	46.87	54.00	-7.13	Vertical	
2400	6.34	30.03	38.87	34.05	31.55	54.00	-22.45	Horizontal	
2483.5	6.22	30.32	39.53	33.56	30.57	54.00	-23.43	Horizontal	
4882	10.57	34.35	40.33	33.78	38.37	54.00	-15.63	Horizontal	
7323	12.91	37.31	40.40	33.68	43.50	54.00	-10.50	Horizontal	
9764	13.89	38.03	37.94	30.00	43.98	54.00	-10.02	Horizontal	
12205	17.95	39.23	39.30	28.96	46.84	54.00	-7.16	Horizontal	

Worse case mode:	GFSK	Test channel:	Highest	Remark:	Peak
------------------	------	---------------	---------	---------	------

Frequency (MHz)	Cable Loss (dB)	Antenna Factor (dB/m)	Preamp Factor (dB)	Read Level (dBuV)	Level (dBuV/m)	Limit Line (dBuV/m)	Over Limit (dB)	polarization
2483.5	6.22	30.32	39.53	56.75	53.76	74.00	-20.24	Vertical
2500	5.76	30.37	39.15	46.45	43.43	74.00	-30.57	Vertical
4960	10.43	34.45	41.03	47.15	51.00	74.00	-23.00	Vertical
7440	12.72	37.37	40.01	47.40	57.48	74.00	-16.52	Vertical
9920	14.24	38.08	37.78	42.24	56.78	74.00	-17.22	Vertical
12400	17.55	39.34	39.48	42.42	59.83	74.00	-14.17	Vertical
2483.5	6.22	30.32	39.53	47.02	44.03	74.00	-29.97	Horizontal
2500	5.76	30.37	39.15	46.77	43.75	74.00	-30.25	Horizontal
4960	10.43	34.45	41.03	46.90	50.75	74.00	-23.25	Horizontal
7440	12.72	37.37	40.01	46.78	56.86	74.00	-17.14	Horizontal
9920	14.24	38.08	37.78	42.71	57.25	74.00	-16.75	Horizontal
12400	17.55	39.34	39.48	43.99	61.40	74.00	-12.60	Horizontal

Worse case mode:	GFSK	Test channel:	Highest	Remark:	Average
------------------	------	---------------	---------	---------	---------

Frequency (MHz)	Cable Loss (dB)	Antenna Factor (dB/m)	Preamp Factor (dB)	Read Level (dBuV)	Level (dBuV/m)	Limit Line (dBuV/m)	Over Limit (dB)	polarization
2483.5	6.22	30.32	39.53	33.56	30.57	54.00	-23.43	Vertical
2500	5.76	30.37	39.15	33.27	30.25	54.00	-23.75	Vertical
4960	10.43	34.45	41.03	34.43	38.28	54.00	-15.72	Vertical
7440	12.72	37.37	40.01	33.57	43.65	54.00	-10.35	Vertical
9920	14.24	38.08	37.78	28.99	43.53	54.00	-10.47	Vertical
12400	17.55	39.34	39.48	29.36	46.77	54.00	-7.23	Vertical
2483.5	6.22	30.32	39.53	33.62	30.63	54.00	-23.37	Horizontal
2500	5.76	30.37	39.15	33.33	30.31	54.00	-23.69	Horizontal
4960	10.43	34.45	41.03	34.41	38.26	54.00	-15.74	Horizontal
7440	12.72	37.37	40.01	33.58	43.66	54.00	-10.34	Horizontal
9920	14.24	38.08	37.78	28.98	43.52	54.00	-10.48	Horizontal
12400	17.55	39.34	39.48	29.35	46.76	54.00	-7.24	Horizontal