

TA Technology (Shanghai) Co., Ltd.

Test Report

Report No.: RZA2009-0995

Page 135 of 153

Glossary:

TSL	tissue simulating liquid
ConvF	sensitivity in TSL / NORM _{x,y,z}
N/A	not applicable or not measured

Calibration is Performed According to the Following Standards:

- a) IEEE Std 1528-2003, "IEEE Recommended Practice for Determining the Peak Spatial-Averaged Specific Absorption Rate (SAR) in the Human Head from Wireless Communications Devices: Measurement Techniques", December 2003
- b) IEC 62209-1, "Procedure to measure the Specific Absorption Rate (SAR) For hand-held devices used in close proximity to the ear (frequency range of 300MHz to 3GHz)", February 2005
- c) Federal Communications Commission Office of Engineering & Technology (FCC OET), "Evaluating Compliance with FCC Guidelines for Human Exposure to Radiofrequency Electromagnetic Fields; Additional Information for Evaluating Compliance of Mobile and Portable Devices with FCC Limits for Human Exposure to Radiofrequency Emissions", Supplement C (Edition 01-01) to Bulletin 65

Additional Documentation:

- d) DASY System Handbook

Methods Applied and Interpretation of Parameters:

- Measurement Conditions: Further details are available from the Validation Report at the end of the certificate. All figures stated in the certificate are valid at the frequency indicated.
- Antenna Parameters with TSL: The dipole is mounted with the spacer to position its feed point exactly below the center marking of the flat phantom section, with the arms oriented parallel to the body axis.
- Feed Point Impedance and Return Loss: These parameters are measured with the dipole positioned under the liquid filled phantom. The impedance stated is transformed from the measurement at the SMA connector to the feed point. The Return Loss ensures low reflected power. No uncertainty required.
- Electrical Delay: One-way delay between the SMA connector and the antenna feed point. No uncertainty required.
- SAR measured: SAR measured at the stated antenna input power.
- SAR normalized: SAR as measured, normalized to an input power of 1 W at the antenna connector.
- SAR for nominal TSL parameters: The measured TSL parameters are used to calculate the nominal SAR result.

TA Technology (Shanghai) Co., Ltd.

Test Report

Measurement Conditions

DASY system configuration, as far as not given on page 1.

DASY Version	DASY5	V5.0
Extrapolation	Advanced Extrapolation	
Phantom	2mm Oval Phantom ELI4	
Distance Dipole Center - TSL	10 mm	with Spacer
Zoom Scan Resolution	dx, dy, dz = 5 mm	
Frequency	1900 MHz ± 1 MHz	

Head TSL parameters

The following parameters and calculations were applied.

	Temperature	Permittivity	Conductivity
Nominal Head TSL parameters	22.0 °C	40.0	1.40 mho/m
Measured Head TSL parameters	(22.0 ± 0.2) °C	39.6 ± 6 %	1.40mho/m ± 6 %
Head TSL temperature during test	(21.9 ± 0.2) °C	----	----

SAR result with Head TSL

SAR averaged over 1 cm ³ (1 g) of Head TSL	Condition	
SAR measured	250 mW input power	9.88 mW / g
SAR normalized	normalized to 1W	39.5 mW / g
SAR for nominal Head TSL parameters ¹	normalized to 1W	37.8 mW / g ± 17.0 % (k=2)

SAR averaged over 10 cm ³ (10 g) of Head TSL	Condition	
SAR measured	250 mW input power	5.0 mW / g
SAR normalized	normalized to 1W	20.0 mW / g
SAR for nominal Head TSL parameters ¹	normalized to 1W	19.8 mW / g ± 16.5 % (k=2)

¹ Correction to nominal TSL parameters according to d), chapter "SAR Sensitivities"

TA Technology (Shanghai) Co., Ltd. Test Report

Report No.: RZA2009-0995

Page 137 of 153

Body TSL parameters

The following parameters and calculations were applied.

	Temperature	Permittivity	Conductivity
Nominal Body TSL parameters	22.0 °C	53.3	1.52 mho/m
Measured Body TSL parameters	(22.0 ± 0.2) °C	52.9 ± 6%	1.55 mho/m ± 6 %
Body TSL temperature during test	(21.8 ± 0.2) °C	----	----

SAR result with Body TSL

SAR averaged over 1 cm^3 (1 g) of Body TSL	Condition	
SAR measured	250 mW input power	10.2 mW / g
SAR normalized	normalized to 1W	40.8 mW / g
SAR for nominal Body TSL parameters ²	normalized to 1W	39.4 mW / g ± 17.0 % (k=2)

SAR averaged over 10 cm^3 (10 g) of Body TSL	Condition	
SAR measured	250 mW input power	5.18 mW / g
SAR normalized	normalized to 1W	20.72 mW / g
SAR for nominal Body TSL parameters ²	normalized to 1W	21.0 mW / g ± 16.5 % (k=2)

² Correction to nominal TSL parameters according to d), chapter "SAR Sensitivities"

TA Technology (Shanghai) Co., Ltd.

Test Report

Report No.: RZA2009-0995

Page 138 of 153

Appendix

Antenna Parameters with Head TSL

Impedance, transformed to feed point	54.8Ω + 4.0 jΩ
Return Loss	- 23.7dB

Antenna Parameters with Body TSL

Impedance, transformed to feed point	47.9Ω + 7.1 jΩ
Return Loss	- 22.6dB

General Antenna Parameters and Design

Electrical Delay (one direction)	1.201 ns
----------------------------------	----------

After long term use with 100W radiated power, only a slight warming of the dipole near the feedpoint can be measured.

The dipole is made of standard semirigid coaxial cable. The center conductor of the feeding line is directly connected to the second arm of the dipole. The antenna is therefore short-circuited for DC-signals. No excessive force must be applied to the dipole arms, because they might bend or the soldered connections near the feedpoint may be damaged.

Additional EUT Data

Manufactured by	SPEAG
Manufactured on	December 10, 2004

DASY5 Validation Report for Head TSL

Date/Time: 2009-7-15 14:15:30

Test Laboratory: TMC, Beijing, China

DUT: Dipole 1900 MHz; Type: D1900V2; Serial: SN: 5d060

Communication System: CW Frequency: 1900 MHz Duty Cycle: 1:1

Medium: Head 1900MHz

Medium parameters used: $f = 1900$ MHz; $\sigma = 1.40$ mho/m; $\epsilon_r = 39.6$; $\rho = 1000$ kg/m³

Phantom section: Flat Section

DASY5 Configuration:

- Probe: ES3DV3 - SN3149; ConvF(5.18, 5.18, 5.18); Calibrated: 08.12.08
- Electronics: DAE4 Sn771; Calibration: 21.11.08
- Phantom: 2mm Oval Phantom ELI4; Type: QDOVA001BB
- Measurement SW: DASY5, V5.0 Build 119.9; Postprocessing SW: SEMCAD, V13.2 Build 87

Pin=250mW; d=10mm/Zoom Scan (7x7x7)/Cube 0:

Measurement grid: dx=5mm, dy=5mm, dz=5mm

Reference Value = 85.1 V/m; Power Drift = -0.057 dB

Peak SAR (extrapolated) = 18.8 W/kg

SAR(1 g) = 9.88 mW/g; SAR(10 g) = 5.0 mW/g

Maximum value of SAR (measured) = 11.5 mW/g

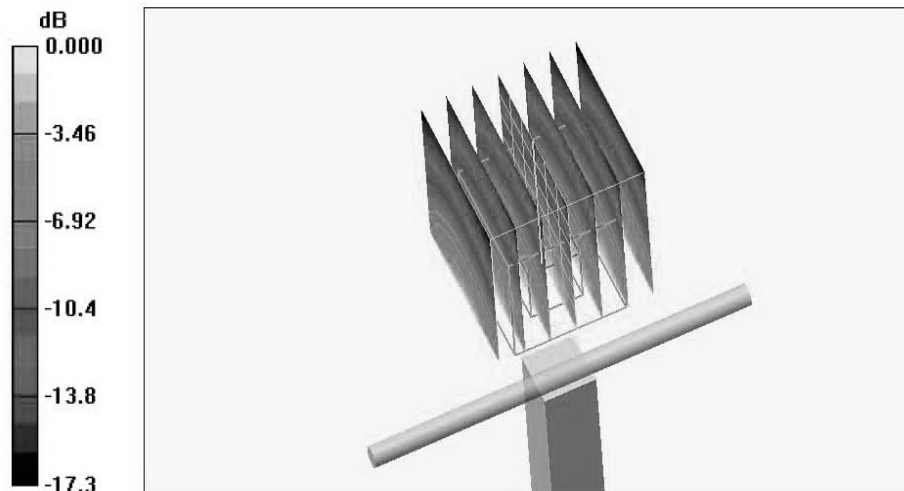

0 dB = 11.5mW/g

Impedance Measurement Plot for Head TSL

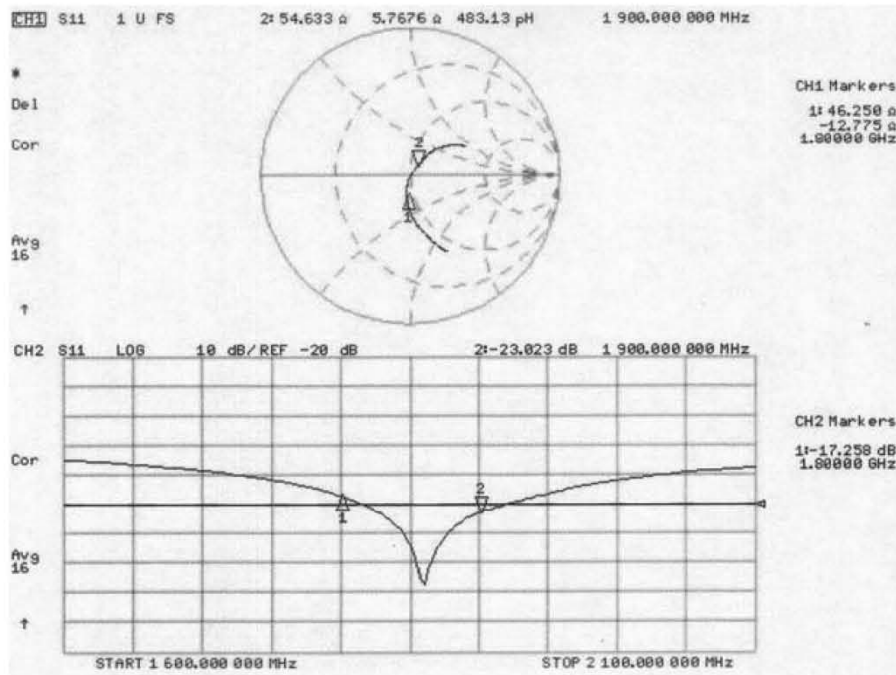

DASY5 Validation Report for Body TSL

Date/Time: 2009-7-15 15:37:31

Test Laboratory: TMC, Beijing, China

DUT: Dipole 1900 MHz; Type: D1900V2; Serial: SN: 5d060

Communication System: CW Frequency: 1900 MHz Duty Cycle: 1:1

Medium: Body 1900MHz

Medium parameters used: $f = 1900$ MHz; $\sigma = 1.55$ mho/m; $\epsilon_r = 52.9$; $\rho = 1000$ kg/m³

Phantom section: Flat Section

DASY5 Configuration:

- Probe: ESSDV3 - SNS149; ConvP(4.97, 4.97, 4.97); Calibrated: 08.12.08
- Electronics: DAE4 Sn771; Calibration: 21.11.08
- Phantom: 2mm Oval Phantom ELI4; Type: QDOVA001BB
- Measurement SW: DASY5, V5.0 Build 119.9; Postprocessing SW: SEMCAD, V13.2 Build 87

Pin=250mW; d=10mm/Zoom Scan (7x7x7)/Cube 0:

Measurement grid: dx=5mm, dy=5mm, dz=5mm

Reference Value = 79.6 V/m; Power Drift = -0.009 dB

Peak SAR (extrapolated) = 19.1 W/kg

SAR(1 g) = 10.2 mW/g; SAR(10 g) = 5.18 mW/g

Maximum value of SAR (measured) = 11.9 mW/g

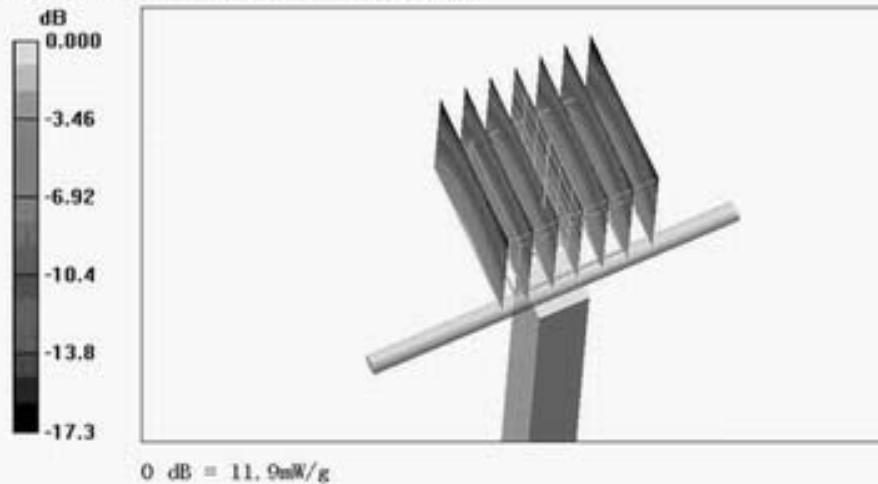

TA Technology (Shanghai) Co., Ltd. Test Report

Report No.: RZA2009-0995

Page 142of 153

Impedance Measurement Plot for Body TSL

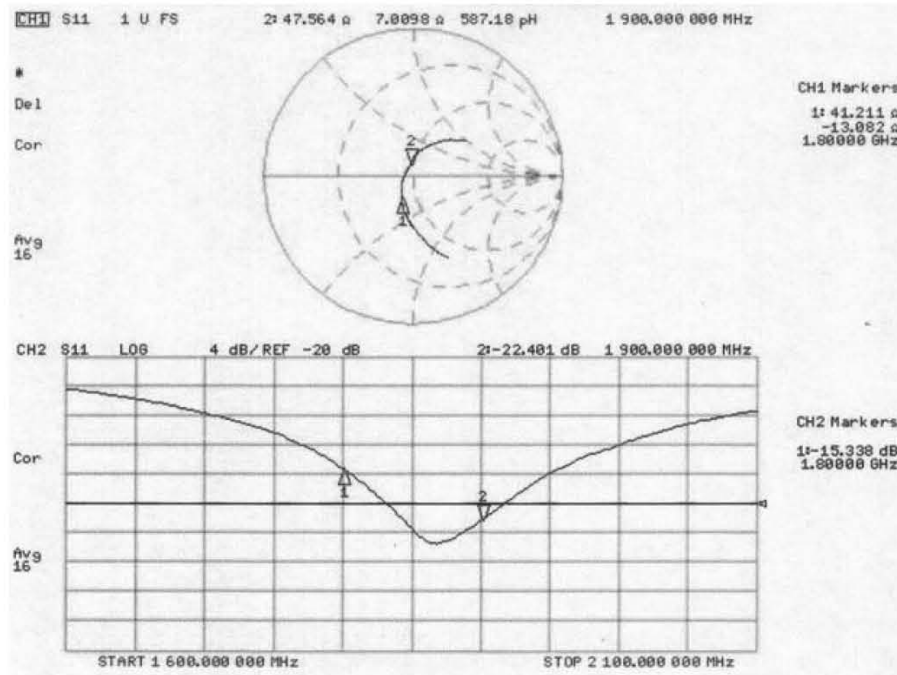

TA Technology (Shanghai) Co., Ltd.

Test Report

Report No.: RZA2009-0995

Page 143of 153

ANNEX G: DAE4 Calibration Certificate

**Calibration Laboratory of
Schmid & Partner
Engineering AG**
Zeughausstrasse 43, 8004 Zurich, Switzerland



S Schweizerischer Kalibrierdienst
S Service suisse d'étalonnage
C Servizio svizzero di taratura
S Swiss Calibration Service

Accredited by the Swiss Accreditation Service (SAS)
The Swiss Accreditation Service is one of the signatories to the EA
Multilateral Agreement for the recognition of calibration certificates

Accreditation No.: **SCS 108**

Client **Auden**

Certificate No: **DAE4-452_Nov08**

CALIBRATION CERTIFICATE

Object **DAE4 - SD 000 D04 BJ - SN: 452**

Calibration procedure(s) **QA CAL-06.v12
Calibration procedure for the data acquisition electronics (DAE)**

Calibration date: **November 18, 2008**

Condition of the calibrated item **In Tolerance**

This calibration certificate documents the traceability to national standards, which realize the physical units of measurements (SI).
The measurements and the uncertainties with confidence probability are given on the following pages and are part of the certificate.

All calibrations have been conducted in the closed laboratory facility: environment temperature (22 ± 3)°C and humidity < 70%.

Calibration Equipment used (M&TE critical for calibration)

Primary Standards	ID #	Cal Date (Certificate No.)	Scheduled Calibration
Fluke Process Calibrator Type 702	SN: 6295803	30-Sep-08 (No: 7673)	Sep-09
Keithley Multimeter Type 2001	SN: 0810278	30-Sep-08 (No: 7670)	Sep-09
Secondary Standards	ID #	Check Date (in house)	Scheduled Check
Calibrator Box V1.1	SE UMS 006 AB 1004	06-Jun-08 (in house check)	In house check: Jun-09

	Name	Function	Signature
Calibrated by:	Dominique Steffen	Technician	
Approved by:	Fin Bornholt	R&D Director	

Issued: November 18, 2008

This calibration certificate shall not be reproduced except in full without written approval of the laboratory.

**Calibration Laboratory of
Schmid & Partner
Engineering AG**
Zeughausstrasse 43, 8004 Zurich, Switzerland



S Schweizerischer Kalibrierdienst
C Service suisse d'étalonnage
S Servizio svizzero di taratura
S Swiss Calibration Service

Accredited by the Swiss Accreditation Service (SAS)
The Swiss Accreditation Service is one of the signatories to the EA
Multilateral Agreement for the recognition of calibration certificates

Accreditation No.: **SCS 108**

Glossary

DAE data acquisition electronics
Connector angle information used in DASY system to align probe sensor X to the robot coordinate system.

Methods Applied and Interpretation of Parameters

- **DC Voltage Measurement:** Calibration Factor assessed for use in DASY system by comparison with a calibrated instrument traceable to national standards. The figure given corresponds to the full scale range of the voltmeter in the respective range.
- **Connector angle:** The angle of the connector is assessed measuring the angle mechanically by a tool inserted. Uncertainty is not required.
- The following parameters as documented in the Appendix contain technical information as a result from the performance test and require no uncertainty.
 - **DC Voltage Measurement Linearity:** Verification of the Linearity at +10% and -10% of the nominal calibration voltage. Influence of offset voltage is included in this measurement.
 - **Common mode sensitivity:** Influence of a positive or negative common mode voltage on the differential measurement.
 - **Channel separation:** Influence of a voltage on the neighbor channels not subject to an input voltage.
 - **AD Converter Values with inputs shorted:** Values on the internal AD converter corresponding to zero input voltage
 - **Input Offset Measurement:** Output voltage and statistical results over a large number of zero voltage measurements.
 - **Input Offset Current:** Typical value for information; Maximum channel input offset current, not considering the input resistance.
 - **Input resistance:** DAE input resistance at the connector, during internal auto-zeroing and during measurement.
 - **Low Battery Alarm Voltage:** Typical value for information. Below this voltage, a battery alarm signal is generated.
 - **Power consumption:** Typical value for information. Supply currents in various operating modes.

TA Technology (Shanghai) Co., Ltd.
Test Report

Report No.: RZA2009-0995

Page 145 of 153

DC Voltage Measurement

A/D - Converter Resolution nominal

High Range: 1LSB = 6.1 μ V, full range = -100...+300 mV

Low Range: 1LSB = 61nV, full range = -1.....+3mV

DASY measurement parameters: Auto Zero Time: 3 sec; Measuring time: 3 sec

Calibration Factors	X	Y	Z
High Range	404.585 \pm 0.1% (k=2)	404.416 \pm 0.1% (k=2)	404.565 \pm 0.1% (k=2)
Low Range	3.97854 \pm 0.7% (k=2)	3.95135 \pm 0.7% (k=2)	3.98063 \pm 0.7% (k=2)

Connector Angle

Connector Angle to be used in DASY system	148 $^{\circ}$ \pm 1 $^{\circ}$
---	-----------------------------------

TA Technology (Shanghai) Co., Ltd.

Test Report

Report No.: RZA2009-0995

Page 146of 153

Appendix

1. DC Voltage Linearity

High Range	Input (μV)	Reading (μV)	Error (%)
Channel X + Input	200000	200000	0.00
Channel X + Input	20000	20006.89	0.03
Channel X - Input	20000	-20003.71	0.02
Channel Y + Input	200000	200000.5	0.00
Channel Y + Input	20000	20008.05	0.04
Channel Y - Input	20000	-20006.61	0.03
Channel Z + Input	200000	199999.6	0.00
Channel Z + Input	20000	20006.84	0.03
Channel Z - Input	20000	-20004.66	0.02

Low Range	Input (μV)	Reading (μV)	Error (%)
Channel X + Input	2000	2000	0.00
Channel X + Input	200	200.19	0.09
Channel X - Input	200	-199.99	0.00
Channel Y + Input	2000	2000	0.00
Channel Y + Input	200	199.38	-0.31
Channel Y - Input	200	-200.73	0.36
Channel Z + Input	2000	2000.1	0.00
Channel Z + Input	200	199.25	-0.38
Channel Z - Input	200	-201.52	0.76

2. Common mode sensitivity

DASY measurement parameters: Auto Zero Time: 3 sec; Measuring time: 3 sec

	Common mode Input Voltage (mV)	High Range Average Reading (μV)	Low Range Average Reading (μV)
Channel X	200	2.99	1.90
	- 200	-1.54	-1.85
Channel Y	200	-8.82	-8.73
	- 200	6.90	6.96
Channel Z	200	9.94	10.21
	- 200	-13.53	-13.21

3. Channel separation

DASY measurement parameters: Auto Zero Time: 3 sec; Measuring time: 3 sec

	Input Voltage (mV)	Channel X (μV)	Channel Y (μV)	Channel Z (μV)
Channel X	200	-	1.31	-0.98
Channel Y	200	1.52	-	2.97
Channel Z	200	-1.16	0.18	-

TA Technology (Shanghai) Co., Ltd.

Test Report

Report No.: RZA2009-0995

Page 147of 153

4. AD-Converter Values with inputs shorted

DASY measurement parameters: Auto Zero Time: 3 sec; Measuring time: 3 sec

	High Range (LSB)	Low Range (LSB)
Channel X	16123	16646
Channel Y	15886	16452
Channel Z	16175	16346

5. Input Offset Measurement

DASY measurement parameters: Auto Zero Time: 3 sec; Measuring time: 3 sec

Input 10M Ω

	Average (μ V)	min. Offset (μ V)	max. Offset (μ V)	Std. Deviation (μ V)
Channel X	0.53	-0.80	1.64	0.33
Channel Y	-1.51	-2.67	-0.89	0.35
Channel Z	-1.99	-3.07	-1.43	0.29

6. Input Offset Current

Nominal Input circuitry offset current on all channels: <25fA

7. Input Resistance

	Zeroing (MOhm)	Measuring (MOhm)
Channel X	0.1999	198.3
Channel Y	0.1999	200.1
Channel Z	0.1999	199.3

8. Low Battery Alarm Voltage (verified during pre test)

Typical values	Alarm Level (VDC)
Supply (+ Vcc)	+7.9
Supply (- Vcc)	-7.6

9. Power Consumption (verified during pre test)

Typical values	Switched off (mA)	Stand by (mA)	Transmitting (mA)
Supply (+ Vcc)	+0.0	+6	+14
Supply (- Vcc)	-0.01	-8	-9