

BBIC default 6620

TITLE:	SC6610	REV:	<REV>
DOCUMENT NO.:	01.BB_DIGITAL	SIZED:	A1
DEPARTMENT:	Hardware DEPT.		
COMPANY:			
DESIGNER:	<DESIGNER>	Last Saved Date:	<undefind>
		SHEET:	1 OF 18

REVISION RECORD			
LTR	ECO NO.	APPROVED:	DATE:

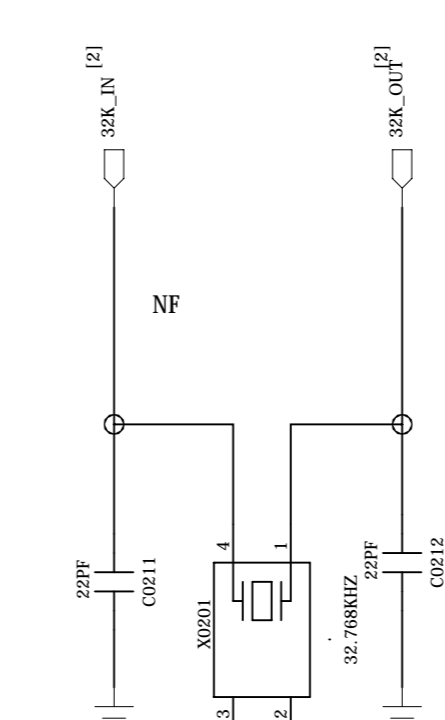
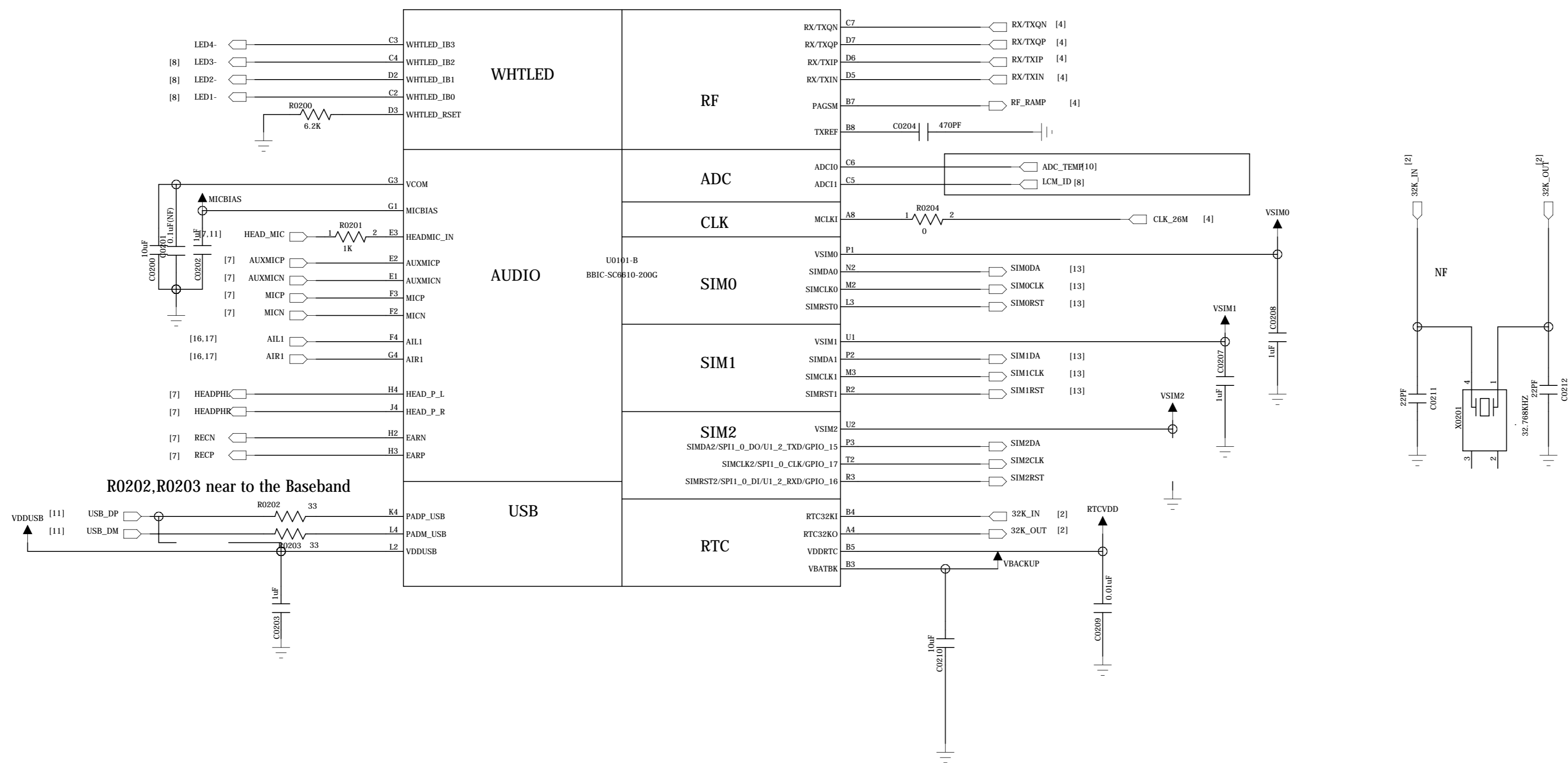

TITLE & REV: SC6610_PLATFORM_REFERENCE_SCH_V1.0.0.sch	
DOCUMENT NO.: HW-SC6610-SCH-2011-0001	
DESIGNER: Franks.Miao	DATED: 2011-02-14
EQA: Robin.Zhang	DATED: 2011-02-14
APPROVED: Guobing.Luan	DATED: 2011-02-14

DESIGNER: Franks.Miao	DATED: 2011-02-14
EQA: Robin.Zhang	DATED: 2011-02-14
APPROVED: Guobing.Luan	DATED: 2011-02-14

DEPARTMENT: Hardware RD.
COMPANY: Spreadtrum communications, Inc.
CONFIDENTIAL AND PROPRIETARY

REVISION RECORD			
LTR	ECO NO.	APPROVED:	DATE:

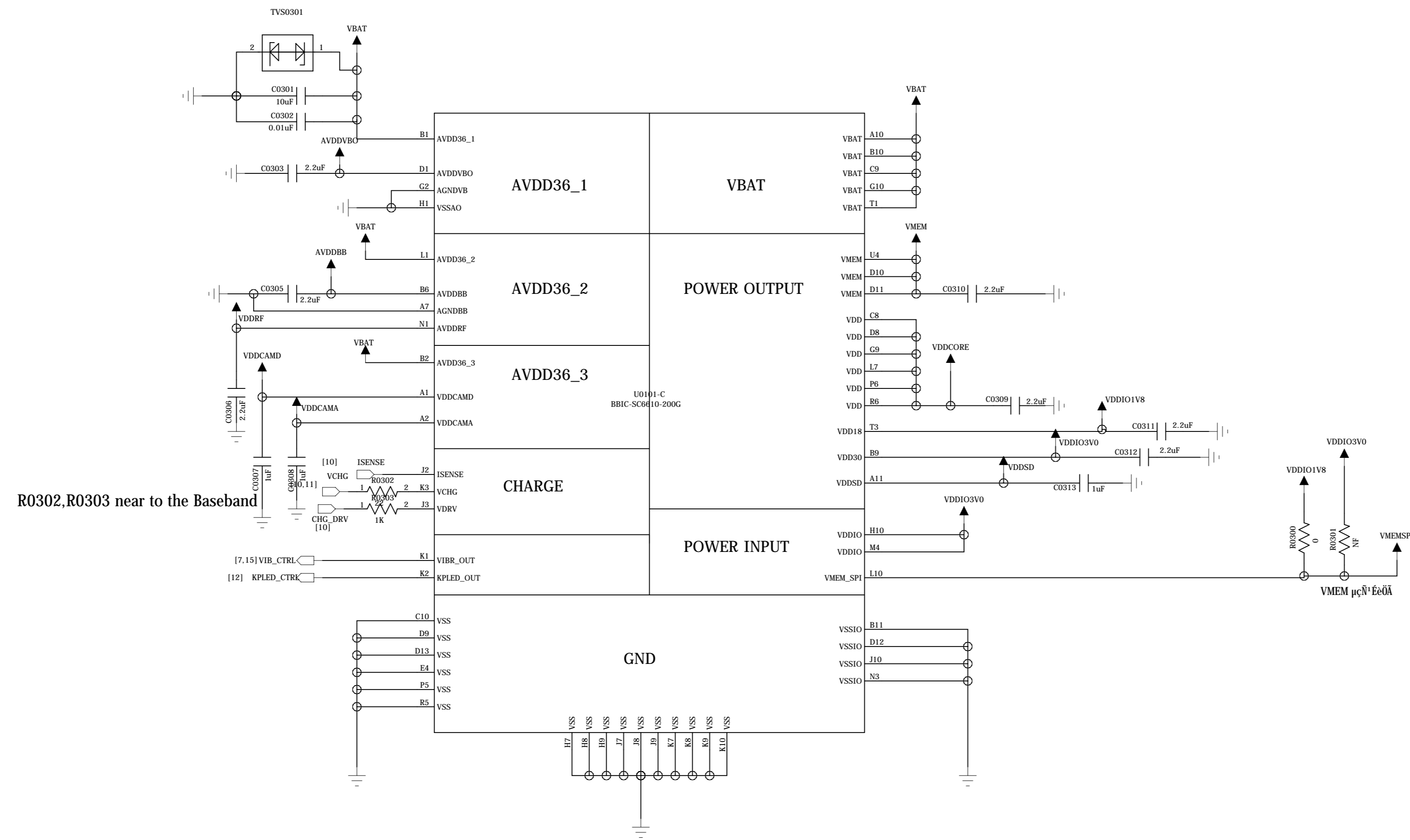

R0302,R0303 near to the Baseband

TITLE & REV:  
SC6610\_PLATFORM\_REFERENCE\_SCH\_V1.0.0.sch  
DOCUMENT NO.:  
HW-SC6610-SCH-2011-0001

DESIGNER: Franks.Miao	DATED: 2011-02-14	DEPARTMENT: Hardware RD.
EQA: Robin.Zhang	DATED: 2011-02-14	COMPANY: Spreadtrum communications, Inc.
APPROVED: Guobing.Luan	DATED: 2011-02-14	CONFIDENTIAL AND PROPRIETARY

REVISION RECORD			
LTR	ECO NO.	APPROVED:	DATE:

D

D

C

C

B

B

A

A

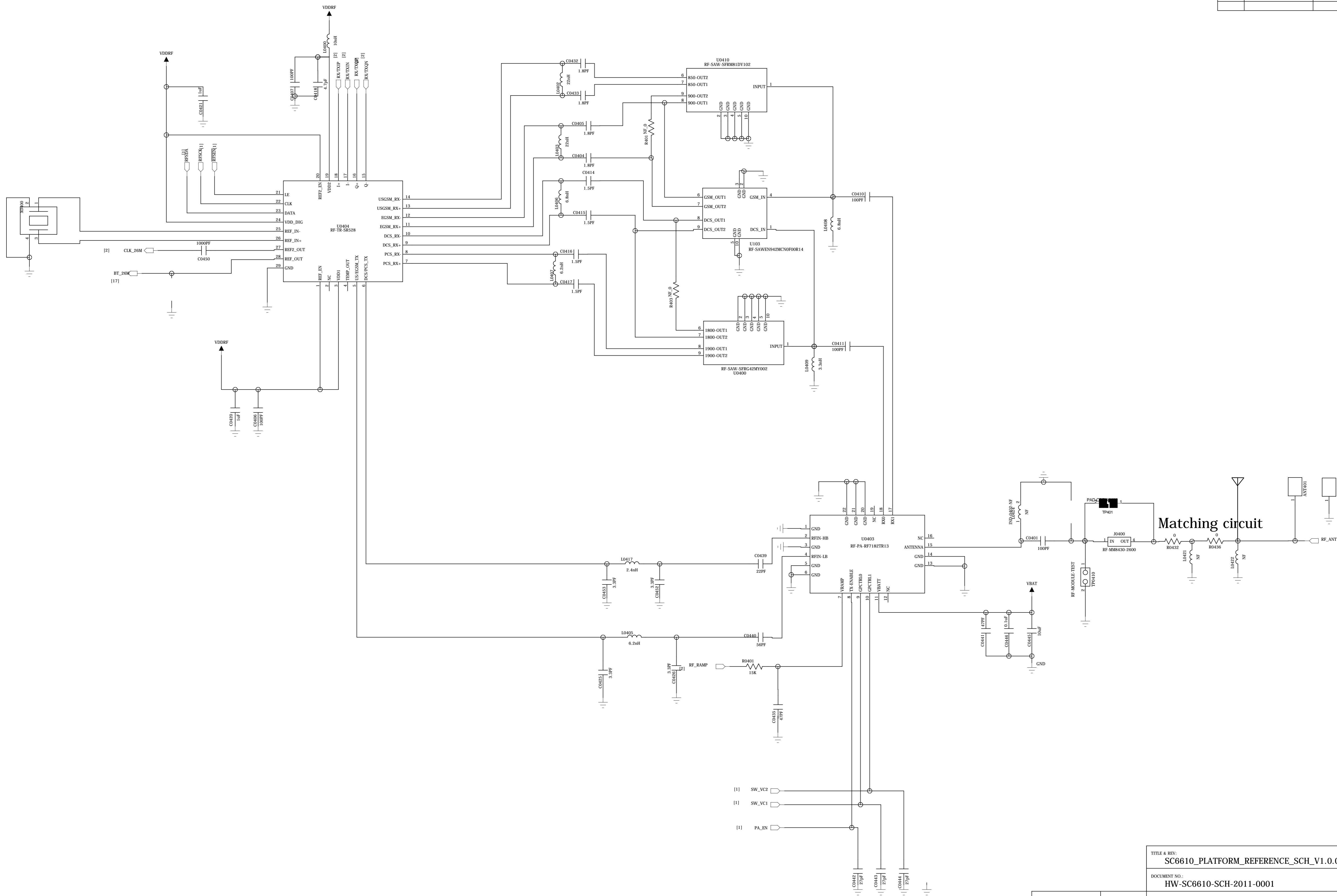

Matching circuit

TITLE & REV: SC6610\_PLATFORM\_REFERENCE\_SCH\_V1.0.0.sch

DOCUMENT NO.: HW-SC6610-SCH-2011-0001

DESIGNER: Franks.Miao	DATED: 2011-02-14	DEPARTMENT: Hardware RD.
EQA: Robin.Zhang	DATED: 2011-02-14	COMPANY: Spreadtrum communications, Inc.
APPROVED: Guobing.Luan	DATED: 2011-02-14	CONFIDENTIAL AND PROPRIETARY

6

5

4

3

2

1

REVISION RECORD			
LTR	ECO NO:	APPROVED:	DATE:

D

D

C

C

B

B

A

A

DESIGNER: Franks.Miao		DATED: 2011-02-14	DEPARTMENT: Hardware RD.
EQA: Robin.Zhang		DATED: 2011-02-14	COMPANY: Spreadtrum communications, Inc.
APPROVED: Guobing.Luan		DATED: 2011-02-14	CONFIDENTIAL AND PROPRIETARY

TITLE & REV: SC6610_PLATFORM_REFERENCE_SCH_V1.0.0.sch
DOCUMENT NO.: HW-SC6610-SCH-2011-0001

REVISION RECORD			
LTR	ECO NO.	APPROVED:	DATE:

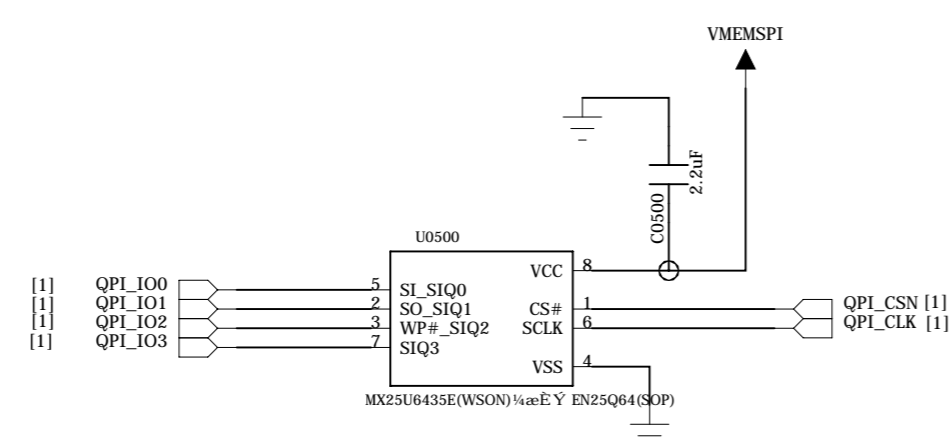

**Serial Flash WSON-8**

MX25U6432E(WSON) 1uE V EN25Q64(8P)

TITLE & REV:  
SC6610\_PLATFORM\_REFERENCE\_SCH\_V1.0.0.sch

DOCUMENT NO.:  
HW-SC6610-SCH-2011-0001

DESIGNER: Franks.Miao	DATED: 2011-02-14	DEPARTMENT: Hardware RD.
EQA: Robin.Zhang	DATED: 2011-02-14	COMPANY: Spreadtrum communications, Inc.
APPROVED: Guobing.Luan	DATED: 2011-02-14	CONFIDENTIAL AND PROPRIETARY

REVISION RECORD			
LTR	ECO NO.	APPROVED:	DATE:

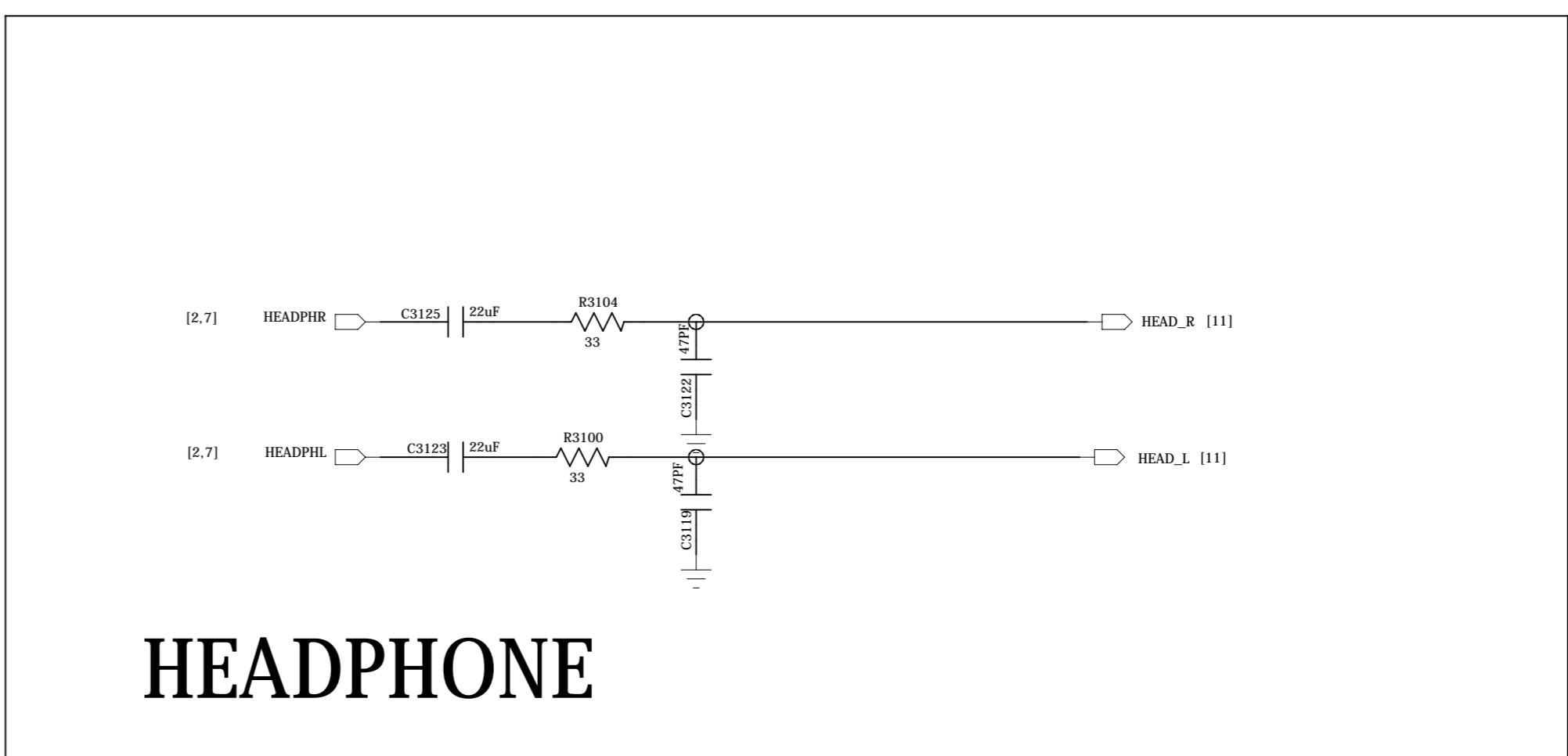
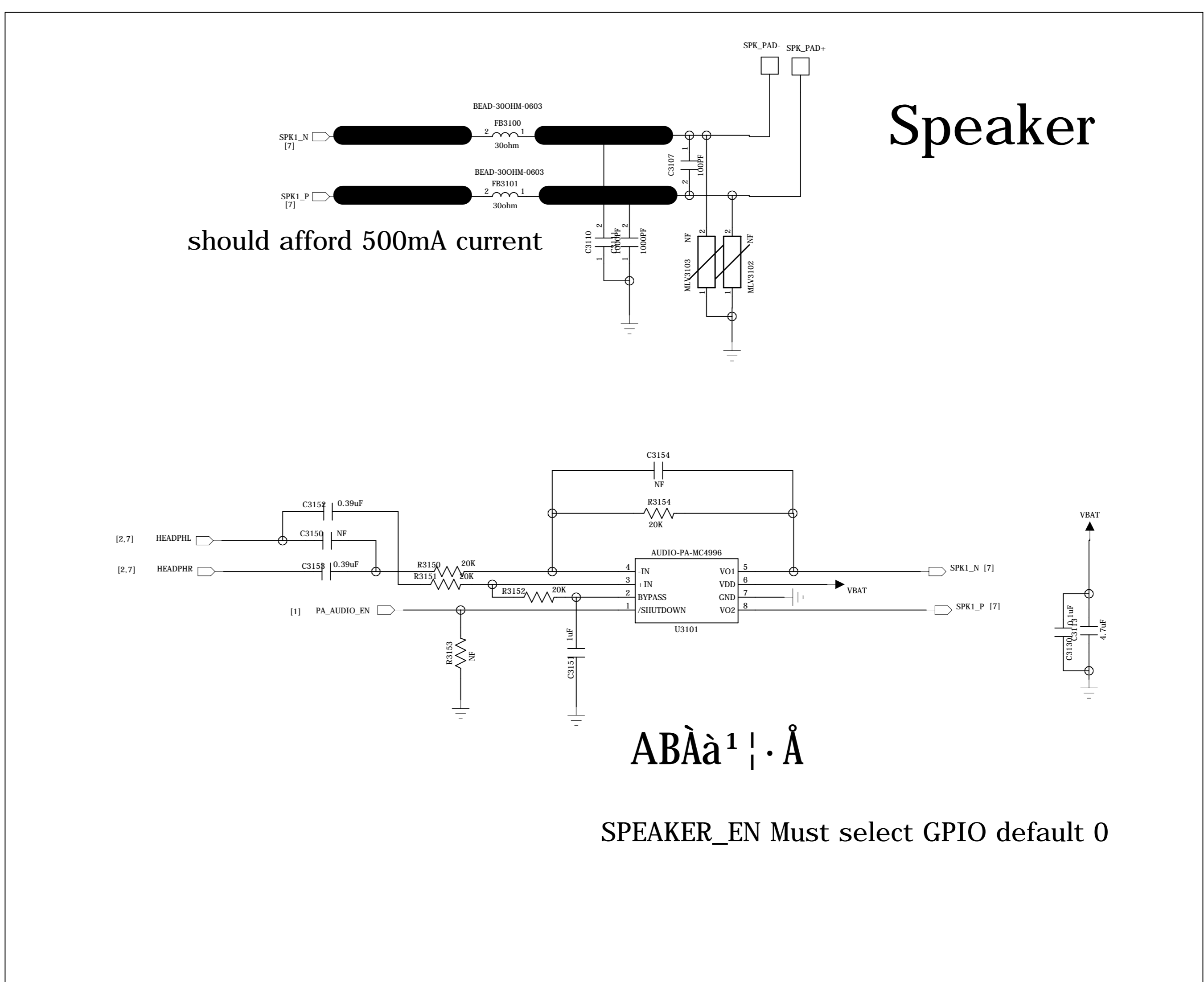
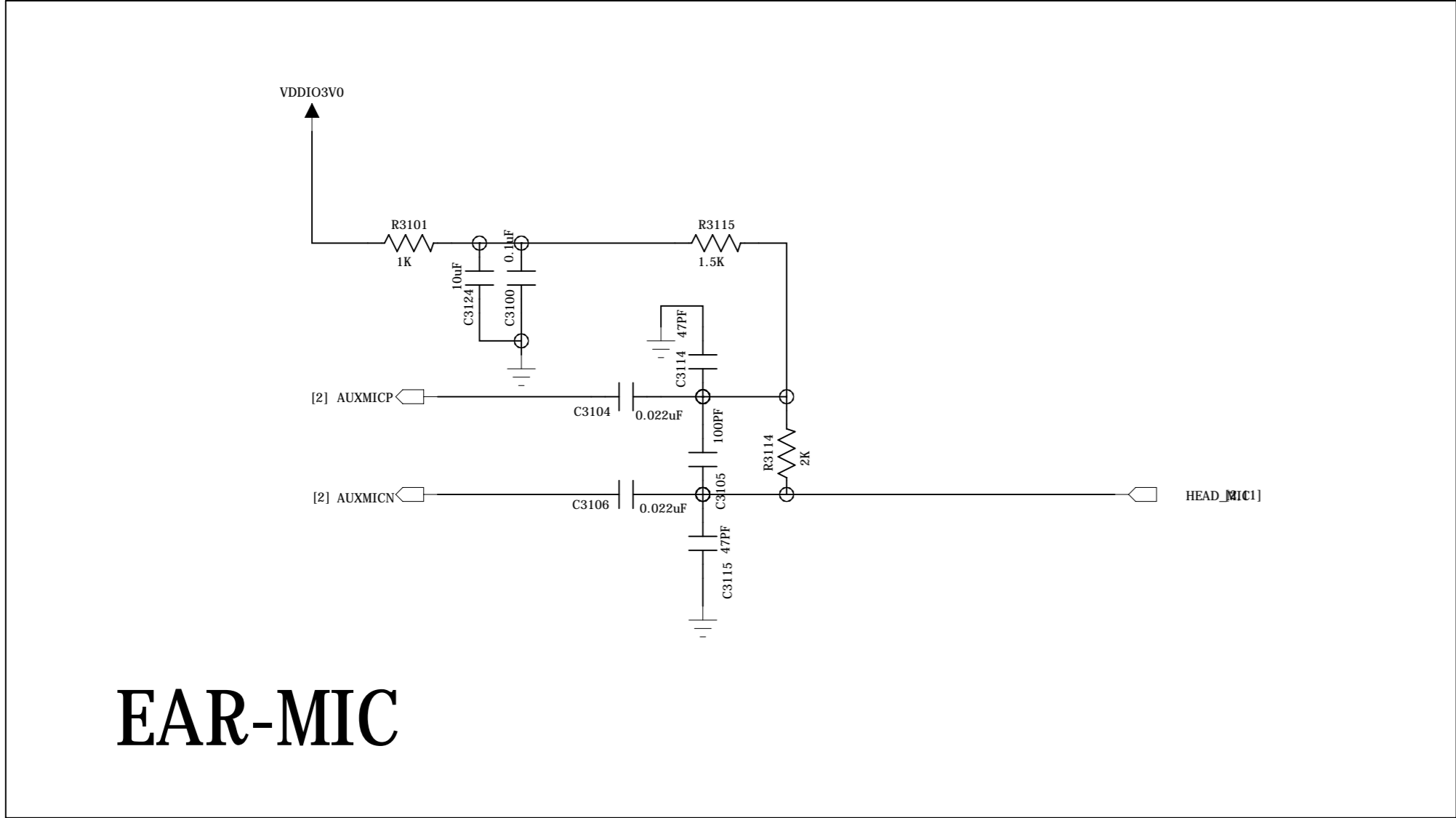
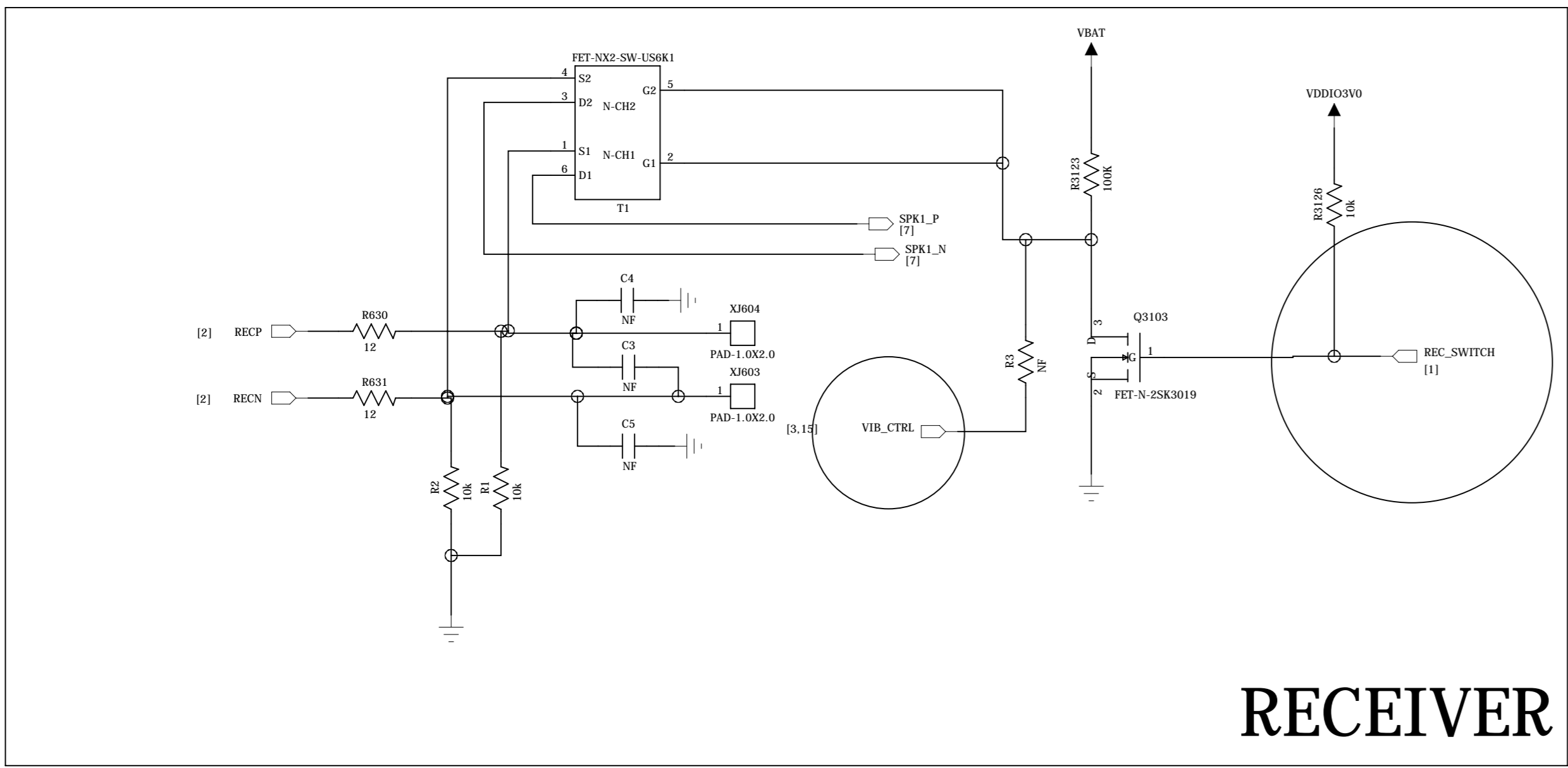
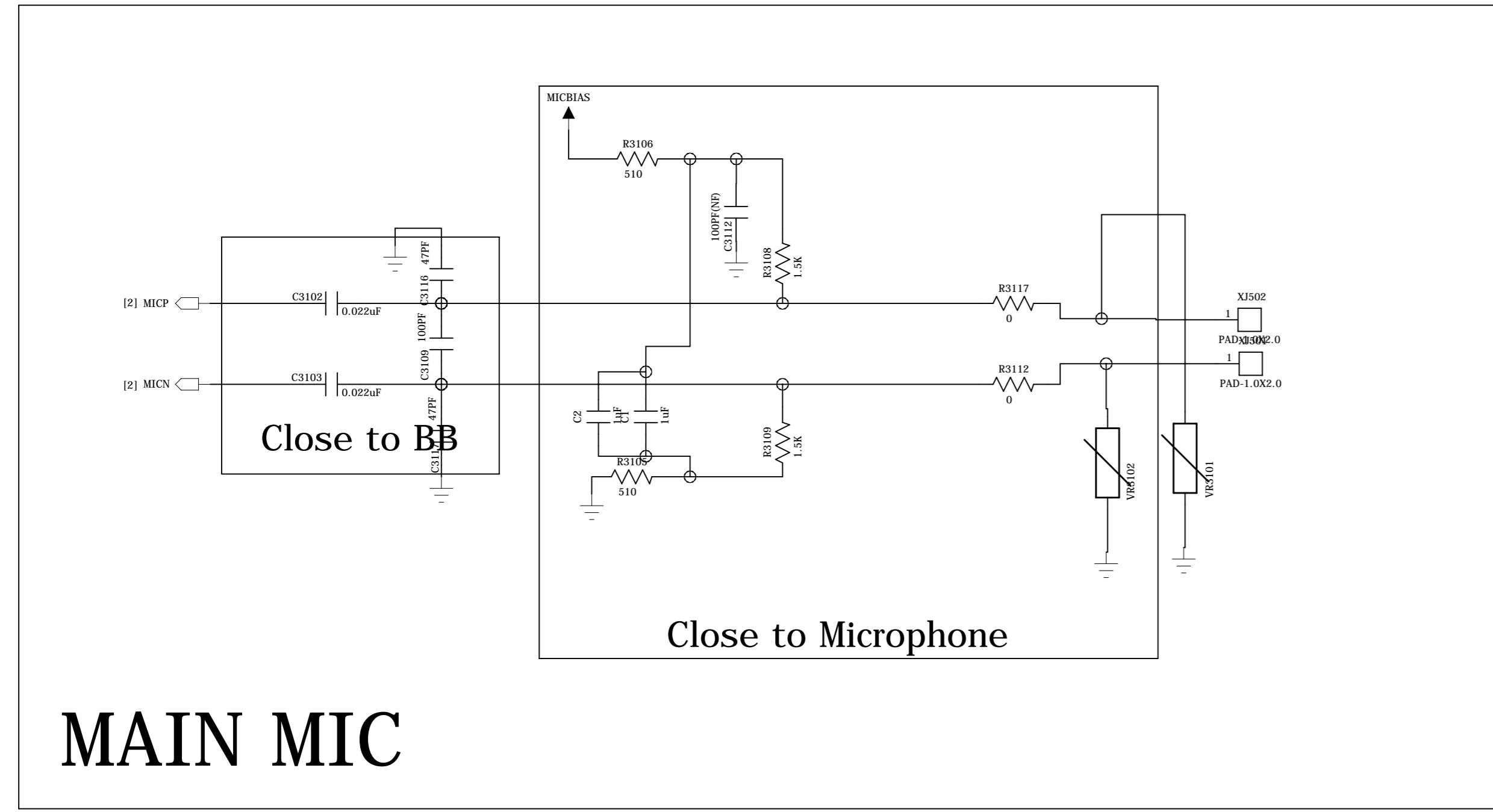

TITLE & REV: SC6610_PLATFORM_REFERENCE_SCH_V1.0.0.sch		
DOCUMENT NO.: HW-SC6610-SCH-2011-0001		
DESIGNER: Franks.Miao	DATED: 2011-02-14	DEPARTMENT: Hardware RD.
EQA: Robin.Zhang	DATED: 2011-02-14	COMPANY: Spreadtrum communications, Inc.
APPROVED: Guobing.Luan	DATED: 2011-02-14	CONFIDENTIAL AND PROPRIETARY

REVISION RECORD			
LTR	ECO NO:	APPROVED:	DATE:

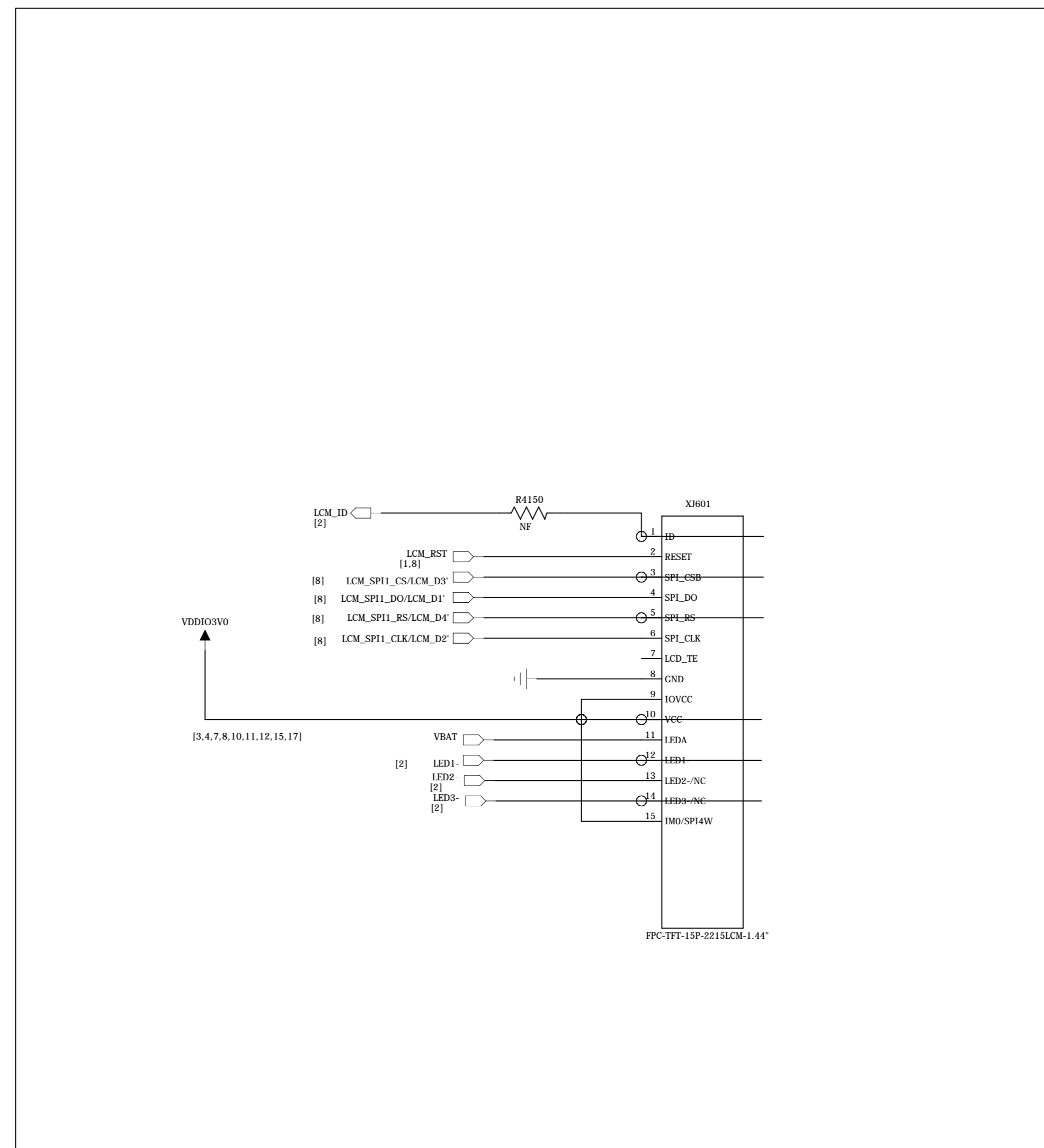
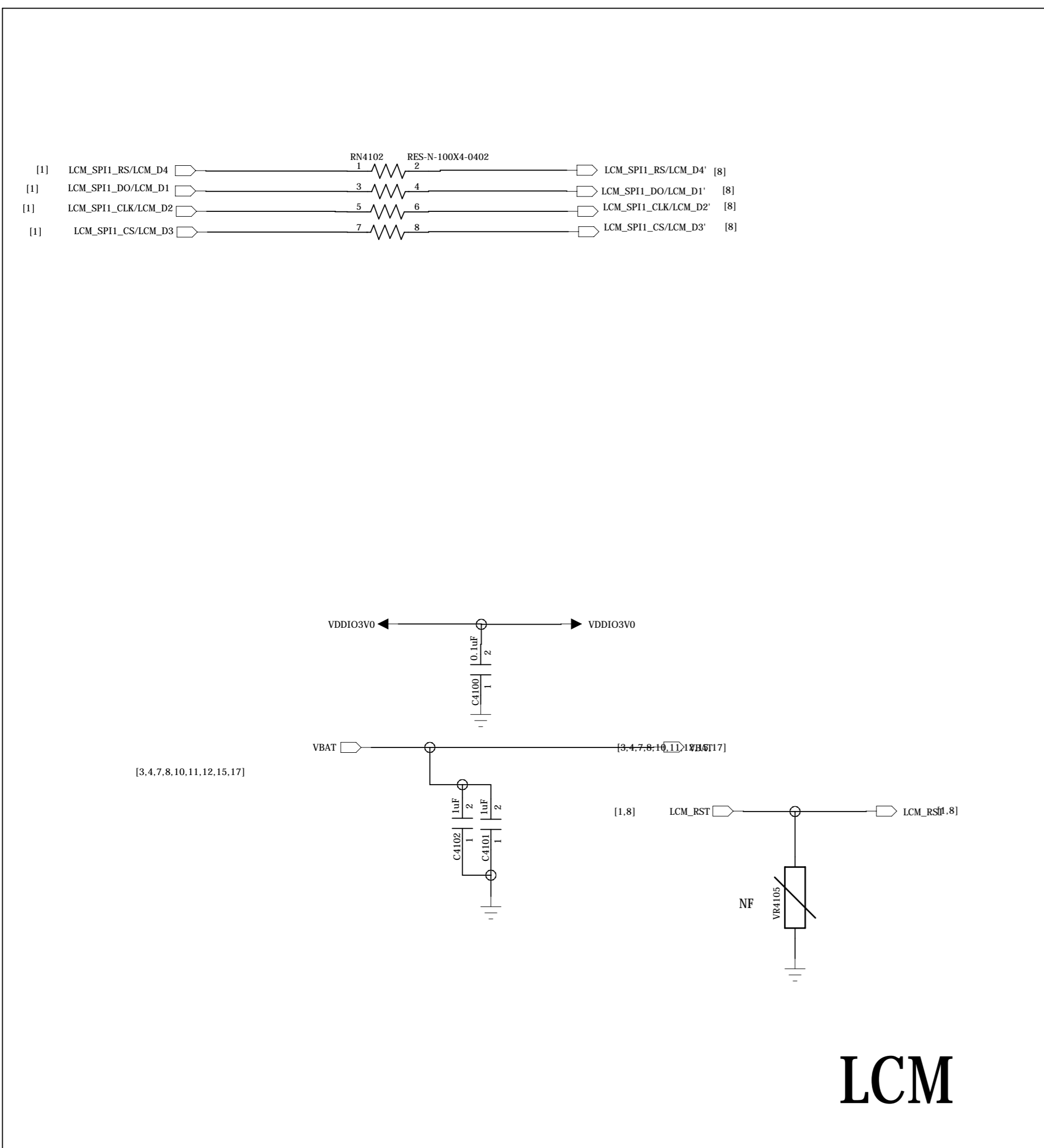

TITLE & REV:  
**SC6610\_PLATFORM\_REFERENCE\_SCH\_V1.0.0.sch**

DOCUMENT NO.:  
**HW-SC6610-SCH-2011-0001**

DESIGNER: <b>Franks.Miao</b>	DATED: <b>2011-02-14</b>	DEPARTMENT: <b>Hardware RD.</b>
EQA: <b>Robin.Zhang</b>	DATED: <b>2011-02-14</b>	COMPANY: <b>Spreadtrum communications, Inc.</b>
APPROVED: <b>Guobing.Luan</b>	DATED: <b>2011-02-14</b>	CONFIDENTIAL AND PROPRIETARY



REVISION RECORD			
LR	ECO NO.	APPROVED:	DATE:

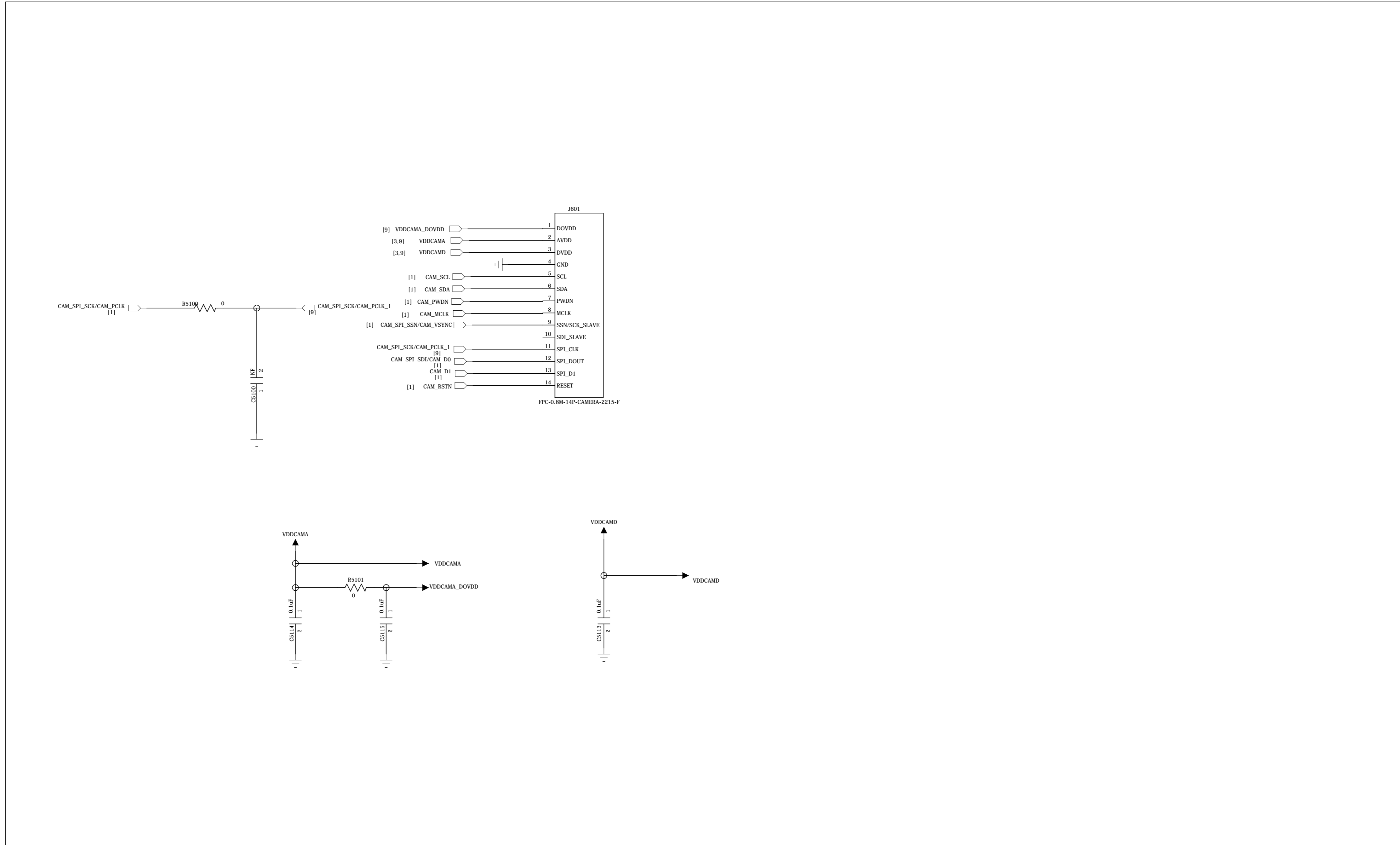

TITLE & REV:  
SC6610\_PLATFORM\_REFERENCE\_SCH\_V1.0.0.sch

DOCUMENT NO.:  
HW-SC6610-SCH-2011-0001

DESIGNER: Franks.Miao	DATED: 2011-02-14	DEPARTMENT: Hardware RD.
EQA: Robin.Zhang	DATED: 2011-02-14	COMPANY: Spreadtrum communications, Inc.
APPROVED: Guobing.Luan	DATED: 2011-02-14	CONFIDENTIAL AND PROPRIETARY

REVISION RECORD			
LTR	ECO NO.	APPROVED:	DATE:

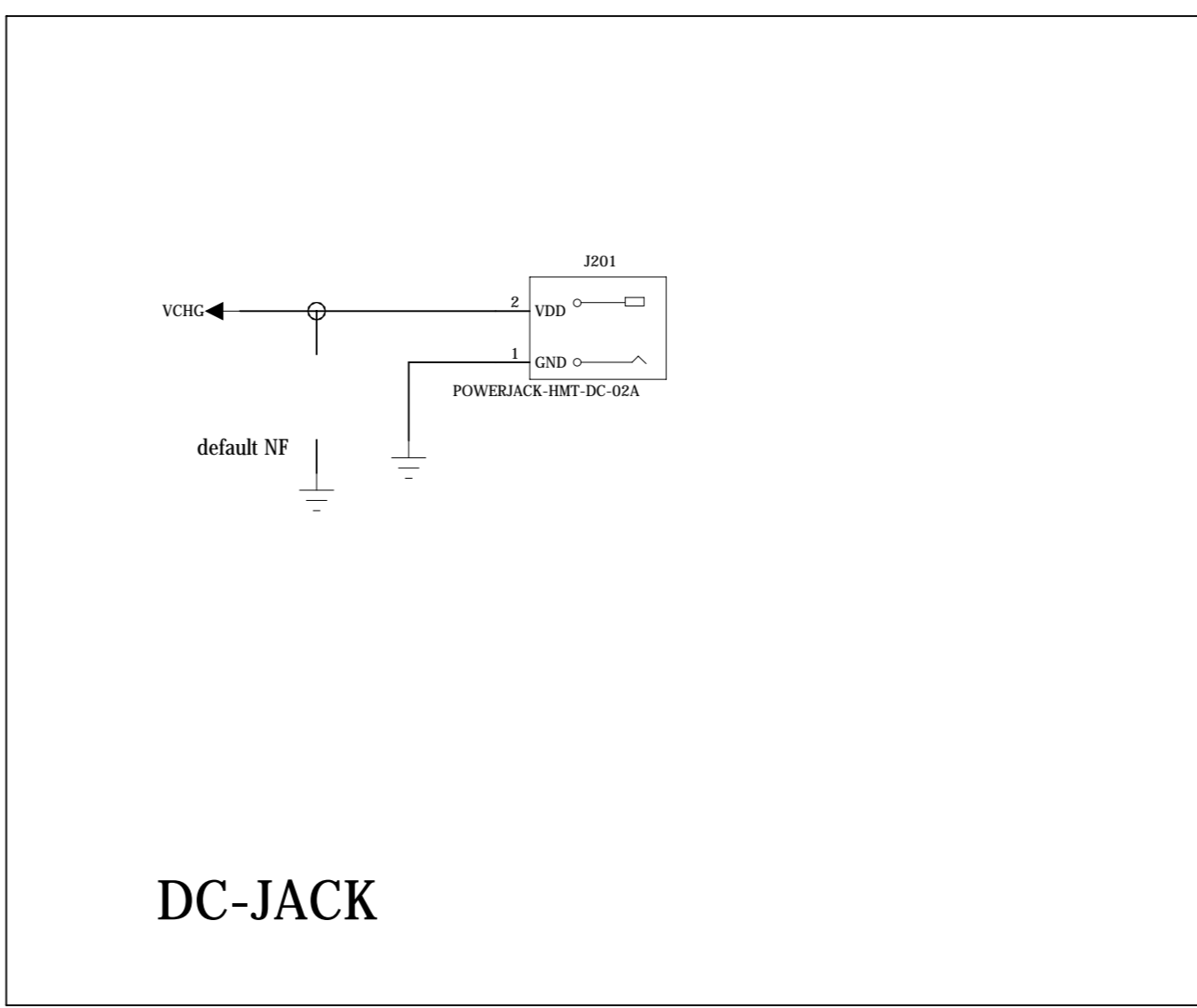
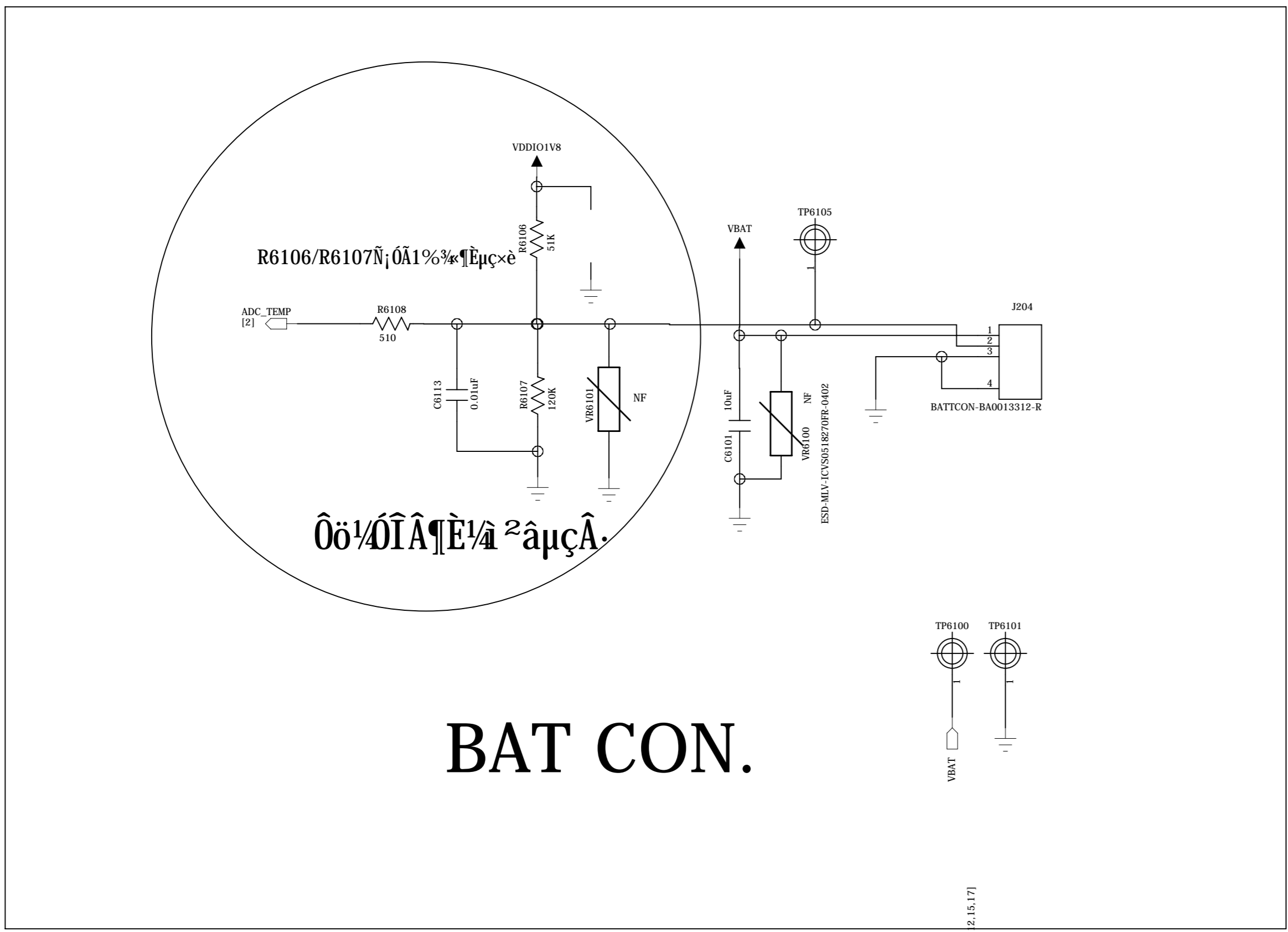
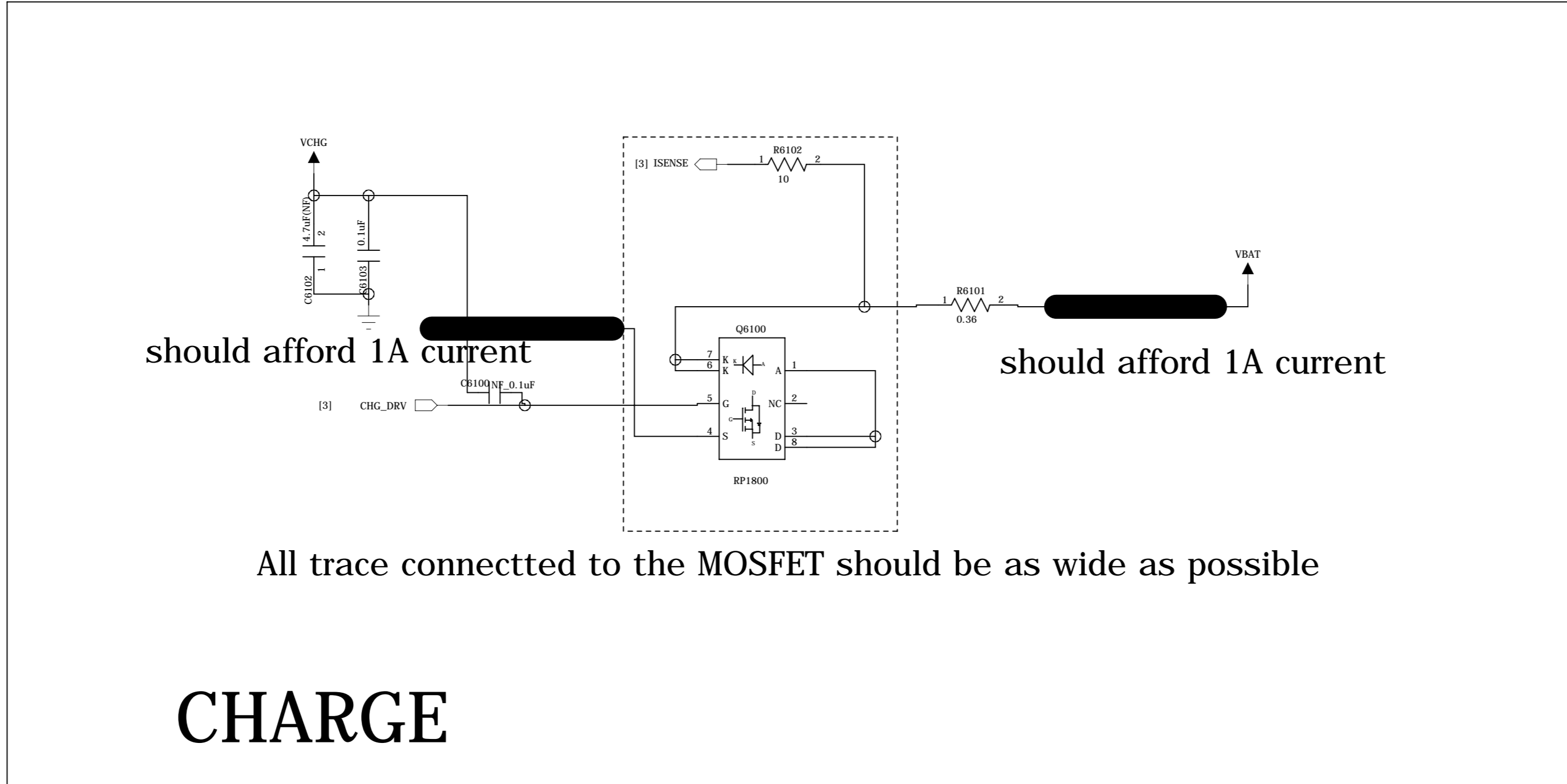

TITLE & REV: SC6610_PLATFORM_REFERENCE_SCH_V1.0.0.sch		
DOCUMENT NO.: HW-SC6610-SCH-2011-0001		
DESIGNER: Franks.Miao	DATED: 2011-02-14	DEPARTMENT: Hardware RD.
EQA: Robin.Zhang	DATED: 2011-02-14	COMPANY: Spreadtrum communications, Inc.
APPROVED: Guobing.Luan	DATED: 2011-02-14	CONFIDENTIAL AND PROPRIETARY

REVISION RECORD			
LTR	ECO NO:	APPROVED:	DATE:

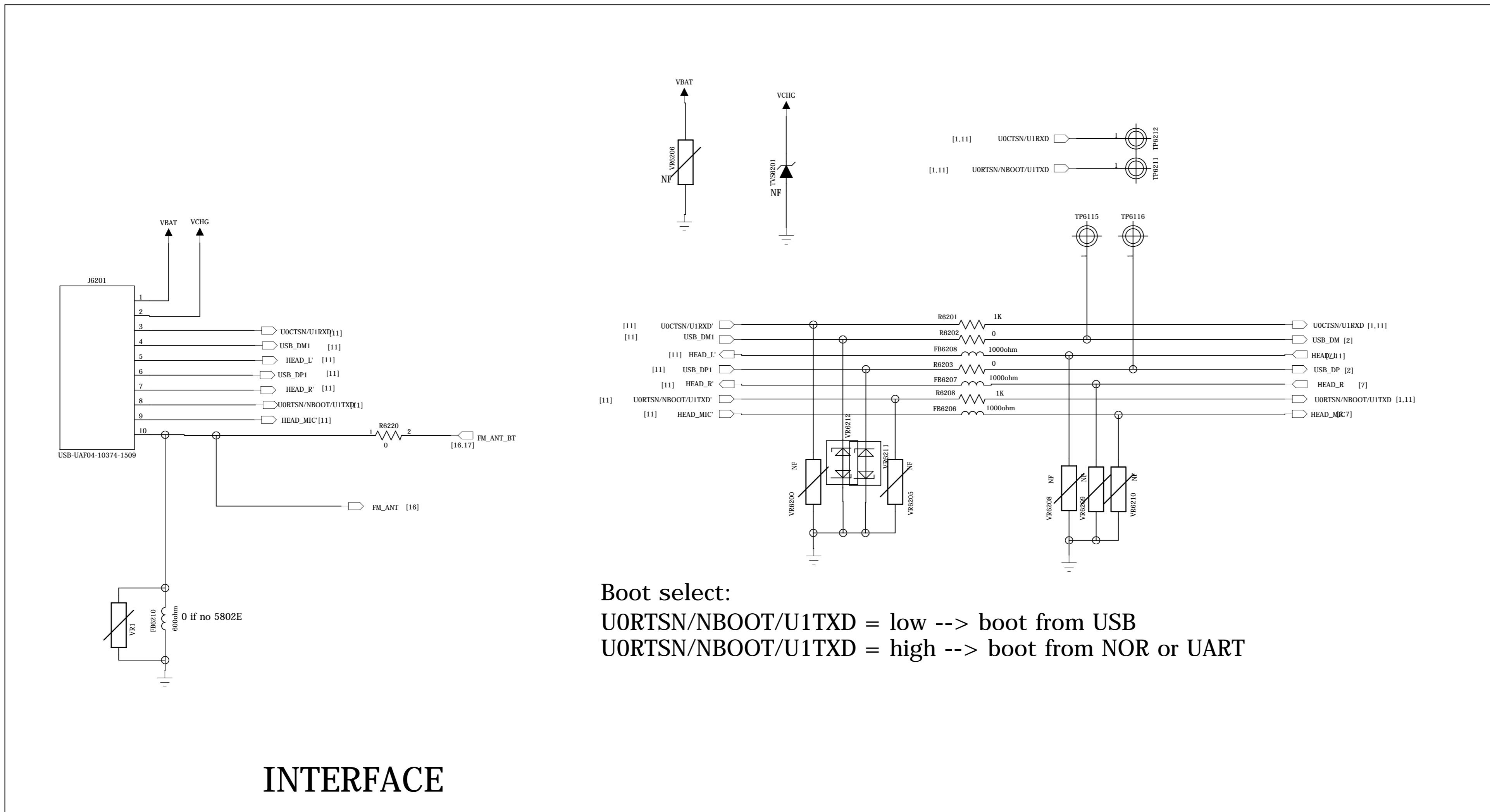

INTERFACE

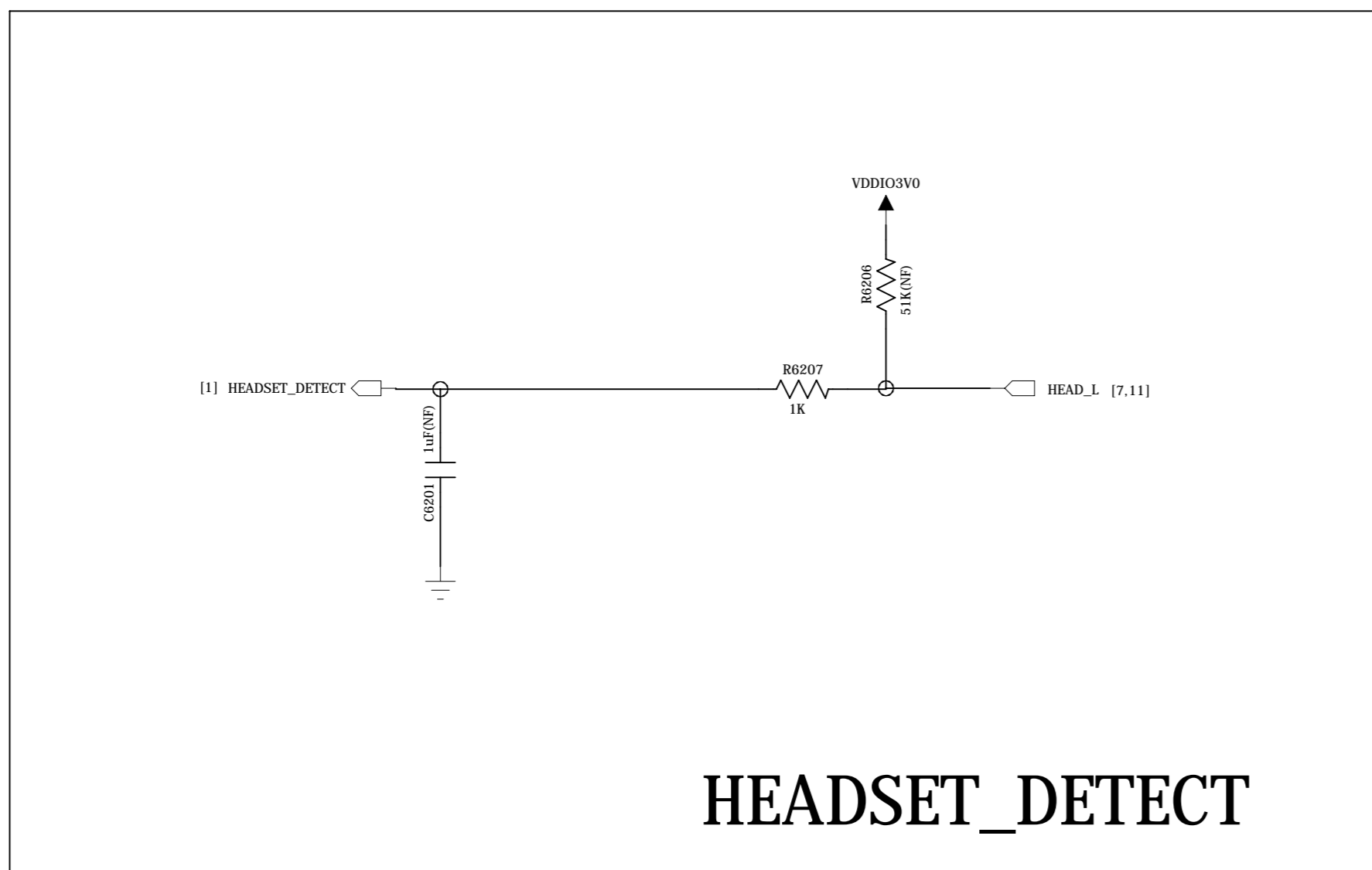

HEADSET\_DETECT

TITLE & REV: SC6610_PLATFORM_REFERENCE_SCH_V1.0.0.sch	
DOCUMENT NO.: HW-SC6610-SCH-2011-0001	

DESIGNER: Franks.Miao	DATED: 2011-02-14	DEPARTMENT: Hardware RD.
EQA: Robin.Zhang	DATED: 2011-02-14	COMPANY: Spreadtrum communications, Inc.
APPROVED: Guobing.Luan	DATED: 2011-02-14	CONFIDENTIAL AND PROPRIETARY

REVISION RECORD			
LTR	ECO NO.	APPROVED:	DATE:

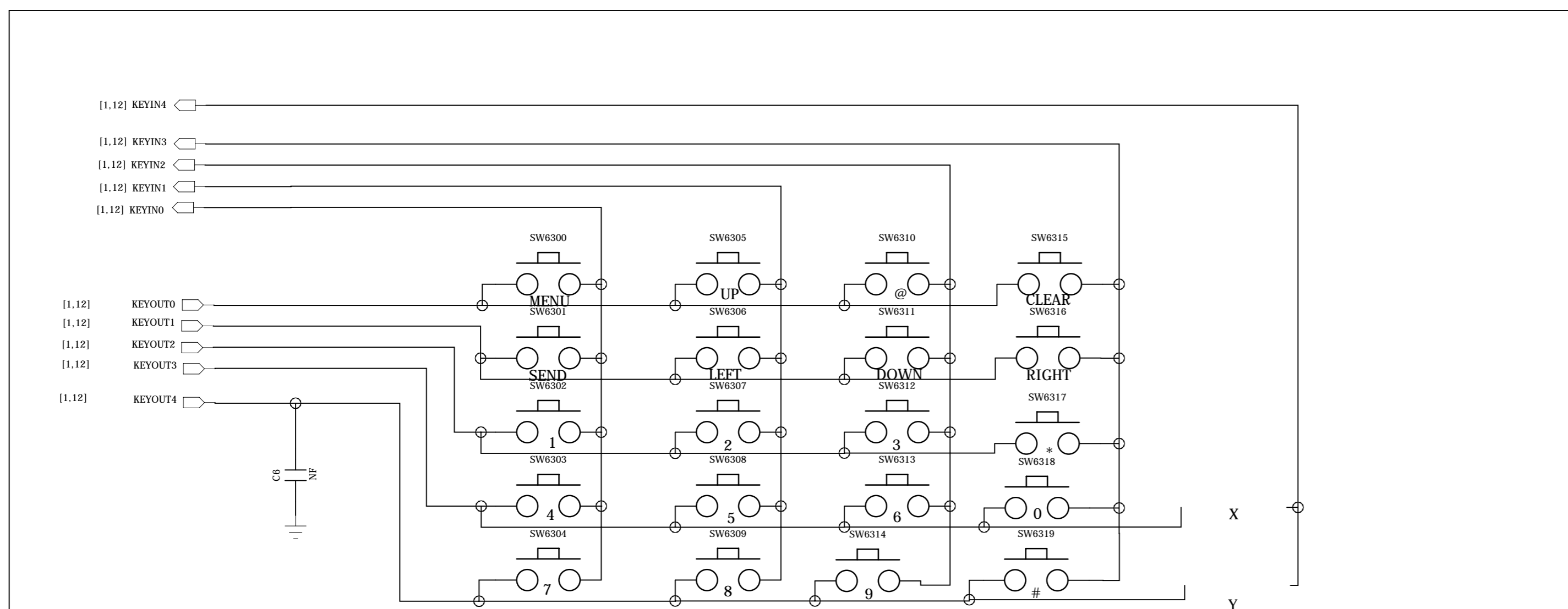

KEYPAD MATRIX

Y¼ü ç ç ½ü ç a » ú¼ü Ò» ± ß · ÅÖÃ [3,4,7,8,10,11,12,15,17]

× ç Òâ ° Í ½á ¹ ¹ È · È Ì ¹ ø × ĐµÄ³ ß ´ ç

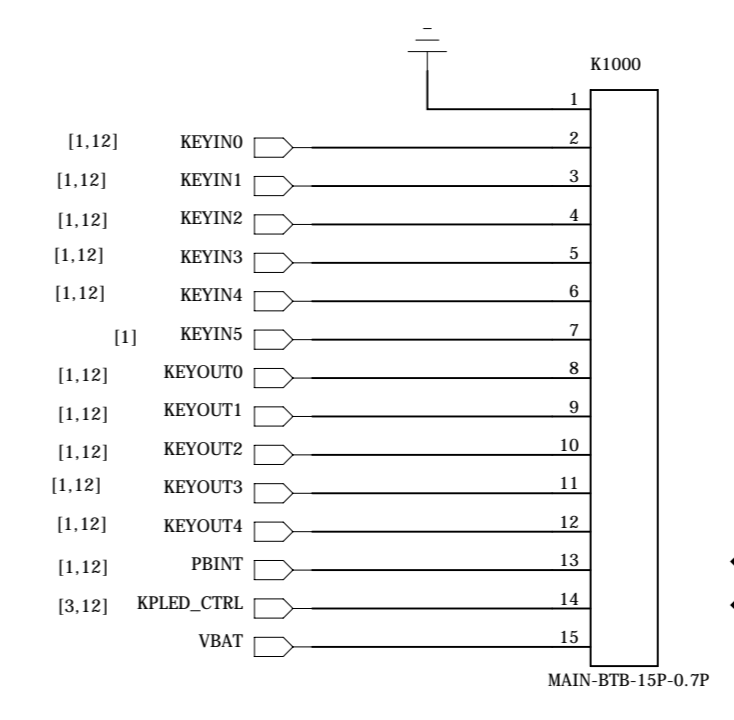

× Ô ¶ · Ò à

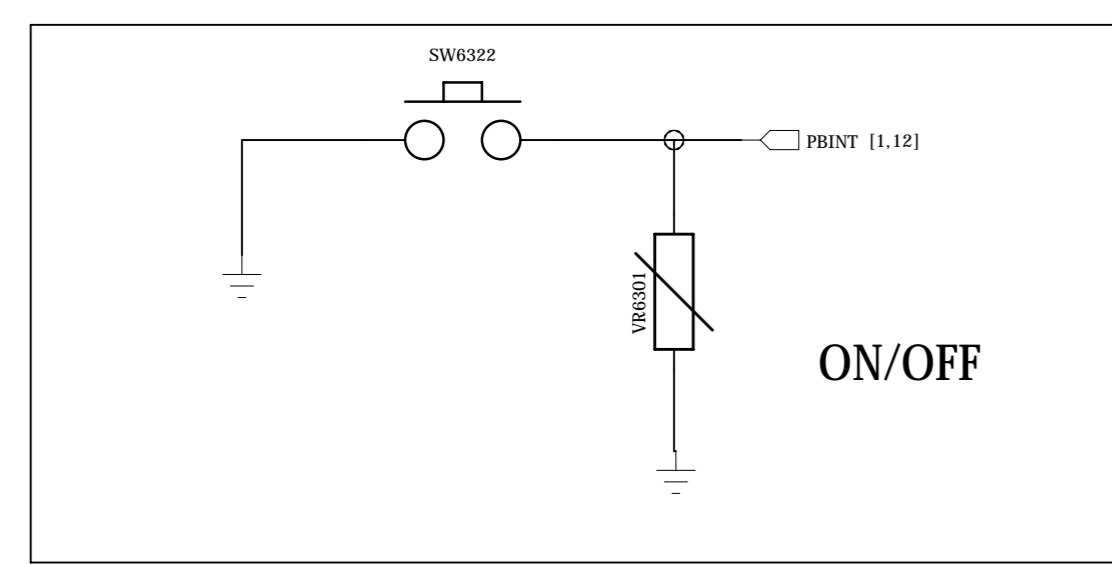

KEYPAD

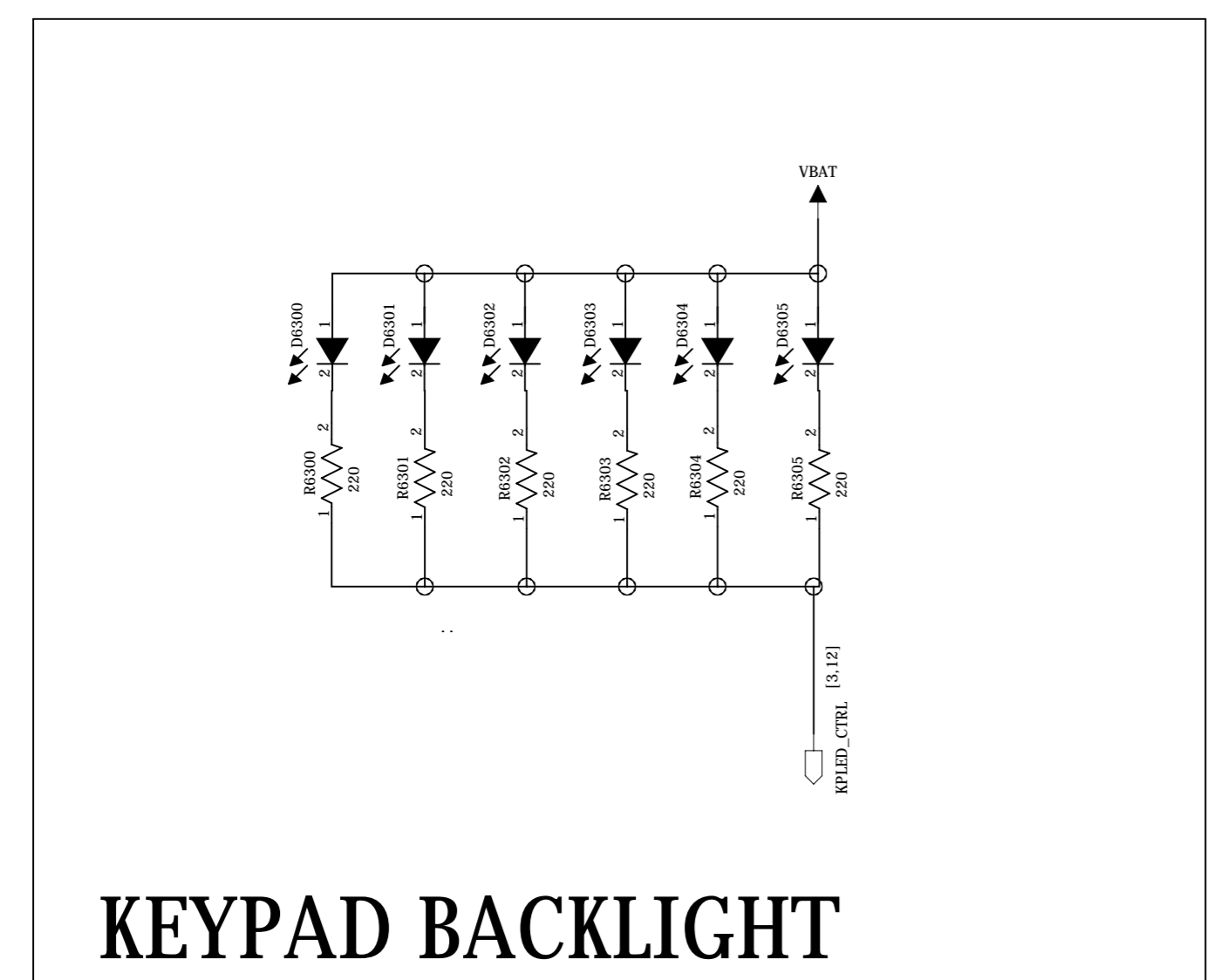

KEYPAD BACKLIGHT

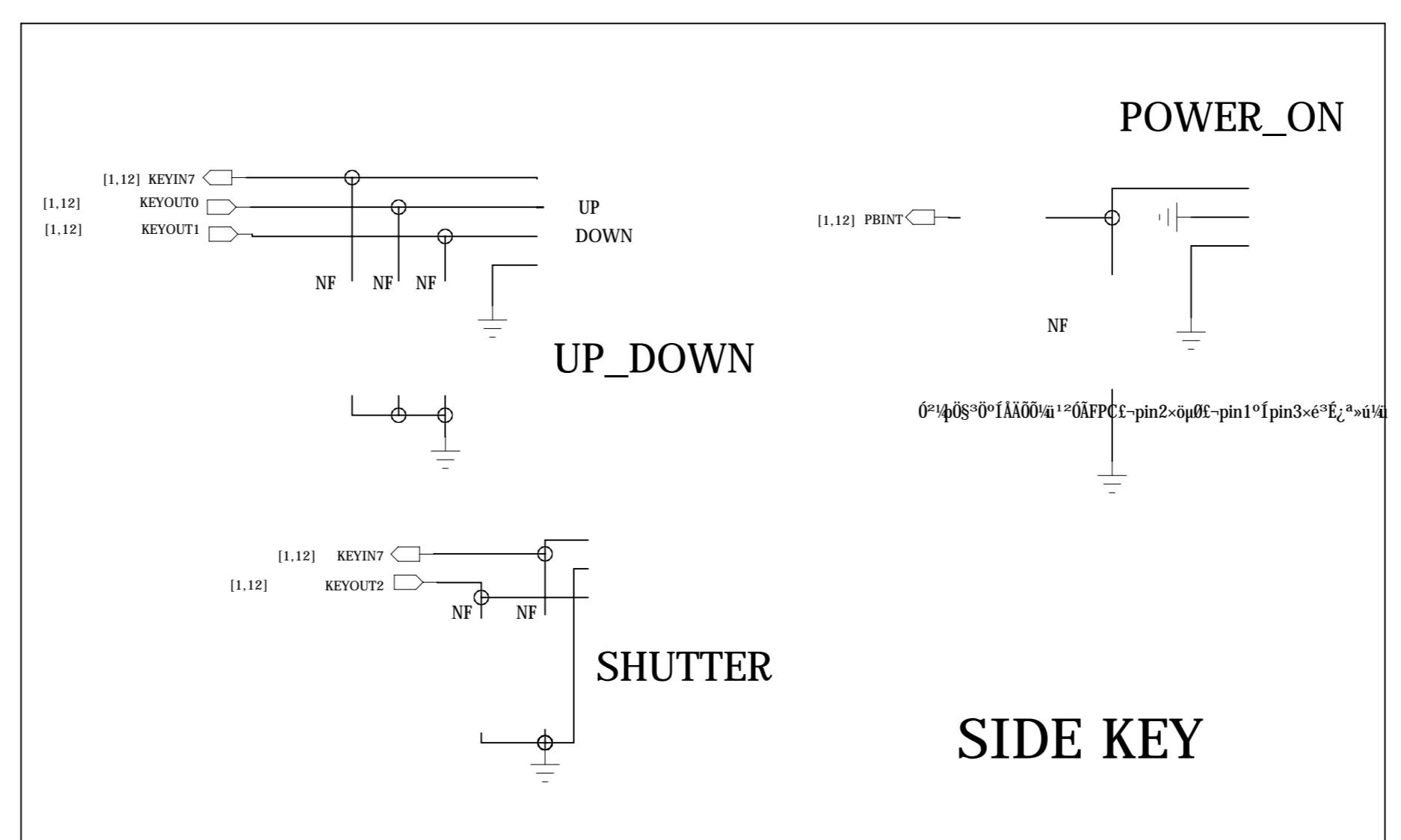

SIDE KEY

TITLE & REV: SC6610_PLATFORM_REFERENCE_SCH_V1.0.0.sch	
DOCUMENT NO.: HW-SC6610-SCH-2011-0001	
DEPARTMENT: Hardware RD.	
COMPANY: Spreadtrum communications, Inc.	
DESIGNER: Franks.Miao	DATED: 2011-02-14
EQA: Robin.Zhang	DATED: 2011-02-14
APPROVED: Guobing.Luan	DATED: 2011-02-14

DESIGNER: Franks.Miao	DATED: 2011-02-14
EQA: Robin.Zhang	DATED: 2011-02-14
APPROVED: Guobing.Luan	DATED: 2011-02-14

REVISION RECORD			
LTR	ECO NO.	APPROVED:	DATE:

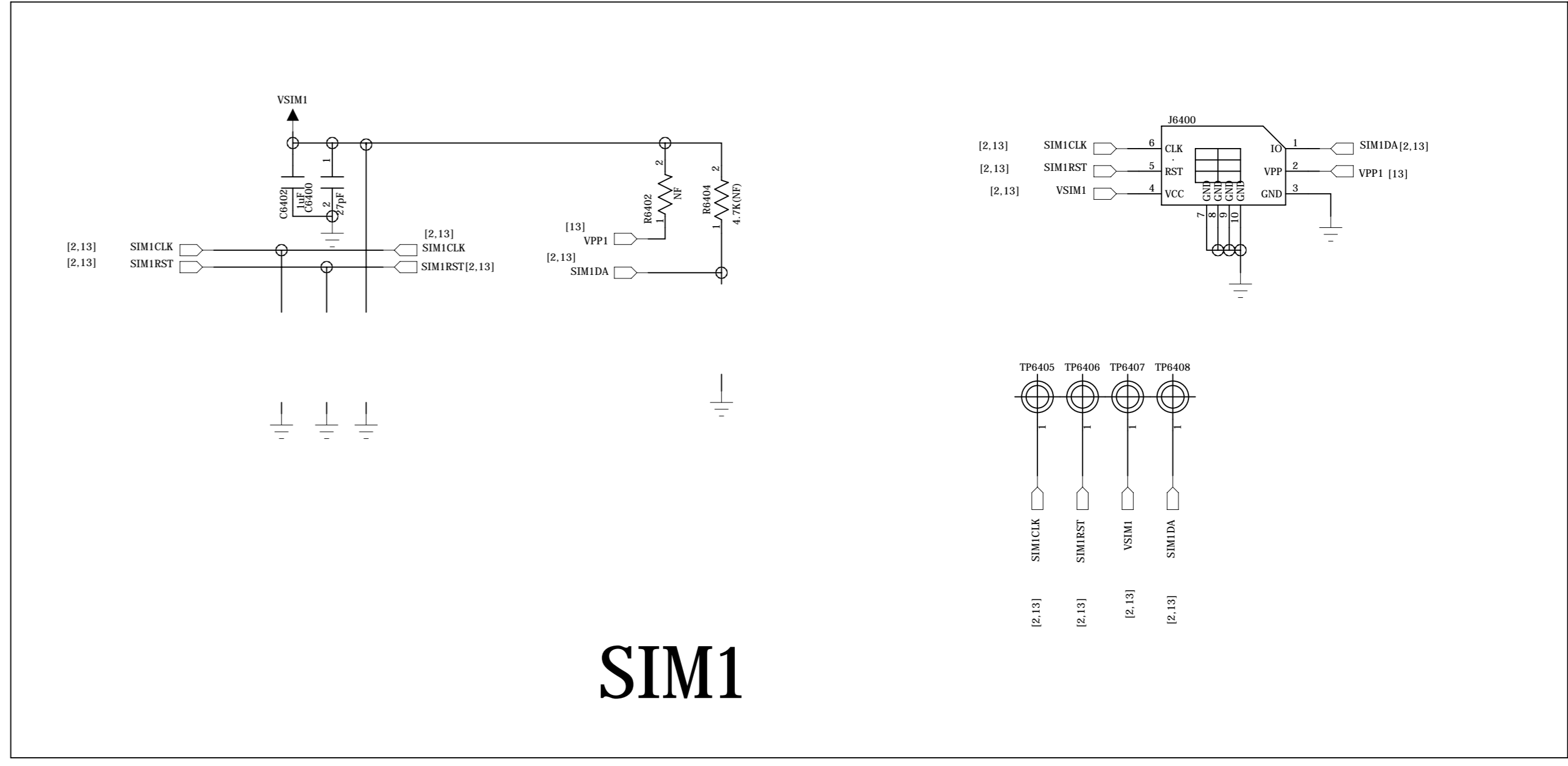
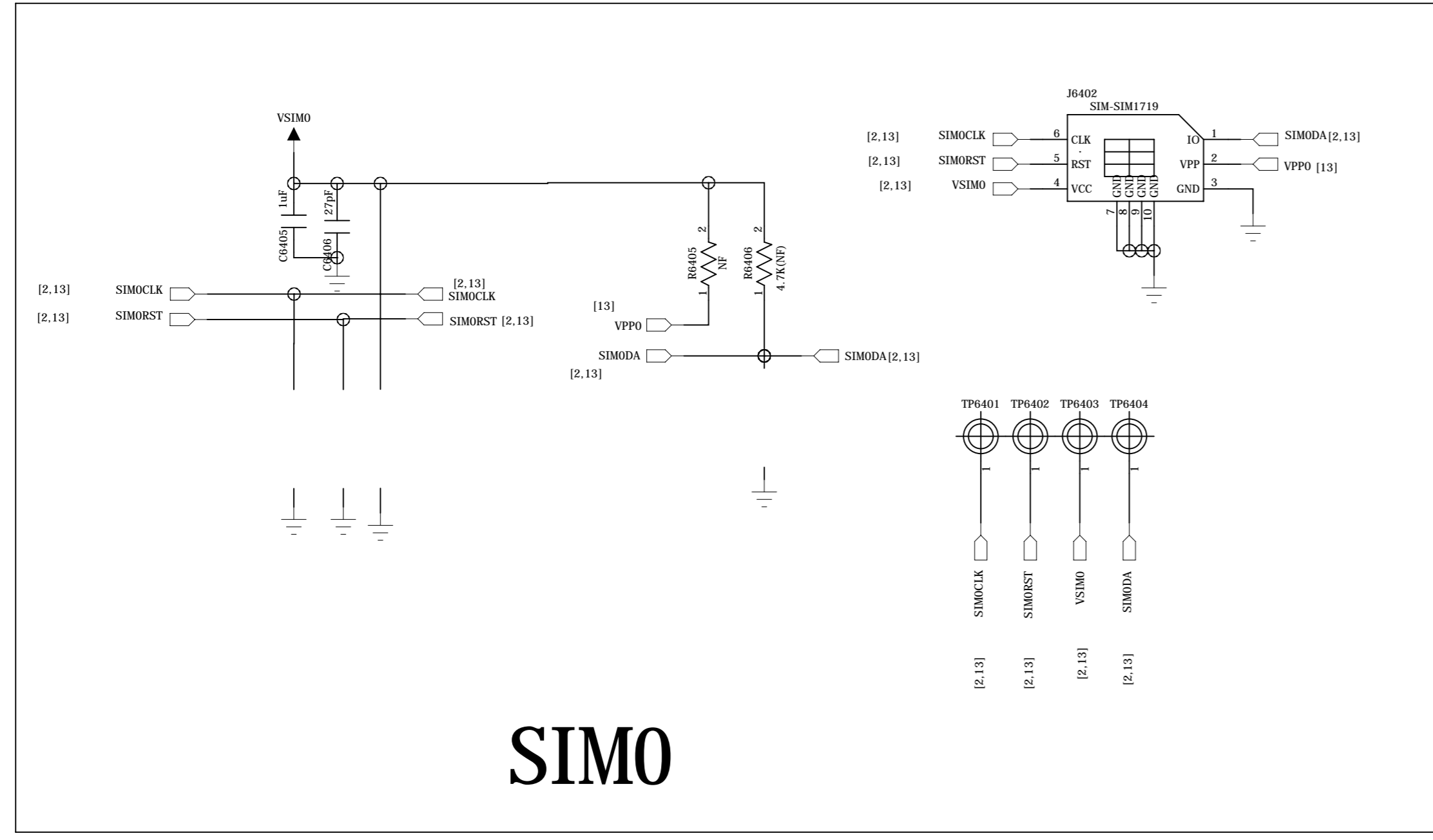

TITLE & REV:  
**SC6610\_PLATFORM\_REFERENCE\_SCH\_V1.0.0.sch**

DOCUMENT NO.:  
**HW-SC6610-SCH-2011-0001**

DESIGNER: <b>Franks.Miao</b>	DATED: <b>2011-02-14</b>	DEPARTMENT: <b>Hardware RD.</b>
EQA: <b>Robin.Zhang</b>	DATED: <b>2011-02-14</b>	COMPANY: <b>Spreadtrum communications, Inc.</b>
APPROVED: <b>Guobing.Luan</b>	DATED: <b>2011-02-14</b>	CONFIDENTIAL AND PROPRIETARY

REVISION RECORD			
LTR	ECO NO.	APPROVED:	DATE:

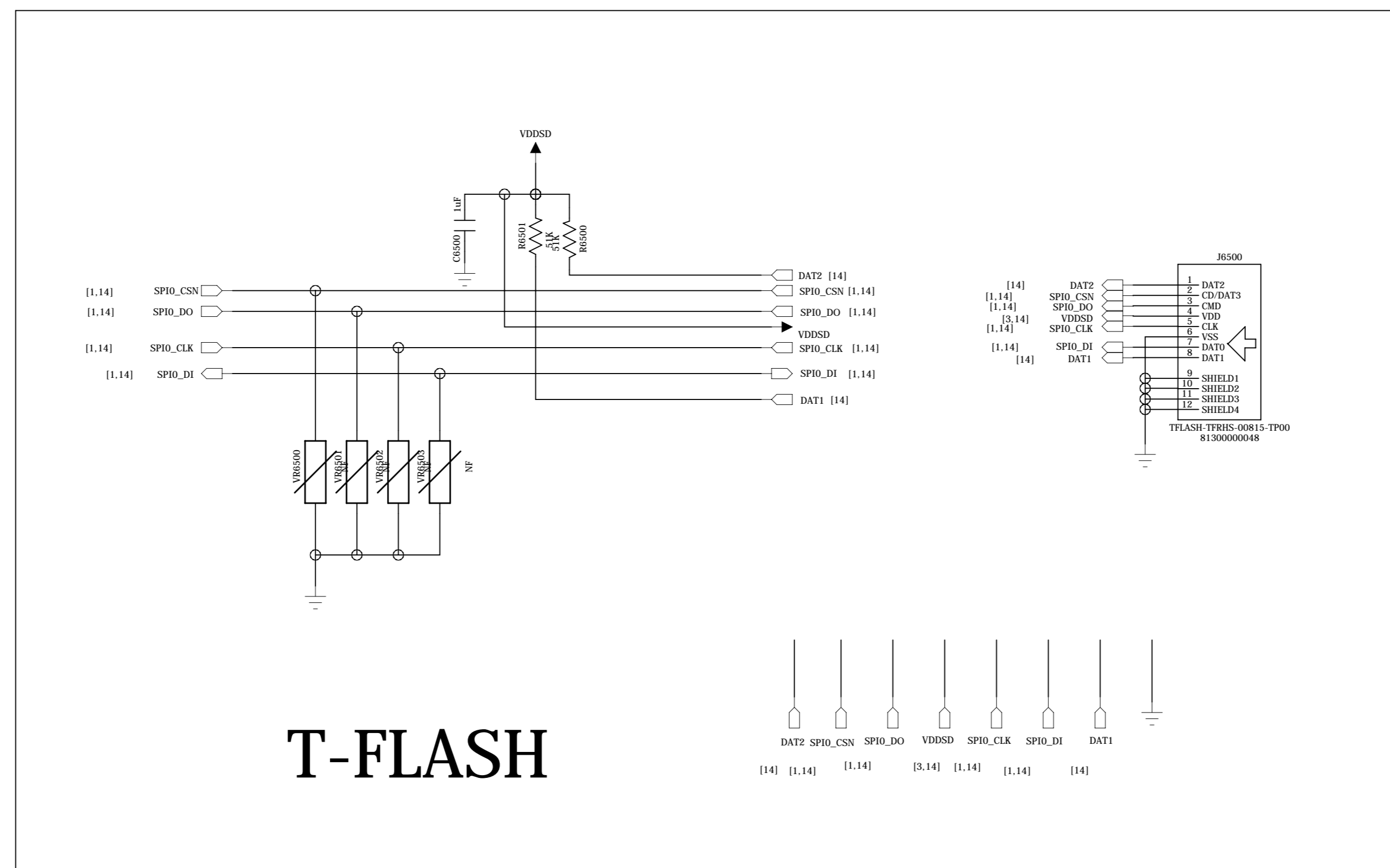

# T-FLASH

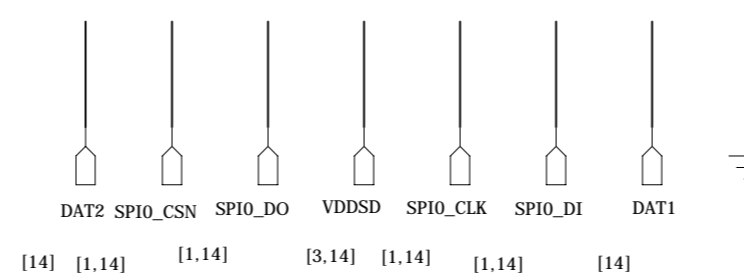

TITLE & REV:  
**SC6610\_PLATFORM\_REFERENCE\_SCH\_V1.0.0.sch**

DOCUMENT NO.:  
**HW-SC6610-SCH-2011-0001**

DESIGNER: <b>Franks.Miao</b>	DATED: <b>2011-02-14</b>
EQA: <b>Robin.Zhang</b>	DATED: <b>2011-02-14</b>
APPROVED: <b>Guobing.Luan</b>	DATED: <b>2011-02-14</b>

DEPARTMENT: <b>Hardware RD.</b>
COMPANY: <b>Spreadtrum communications, Inc.</b>
CONFIDENTIAL AND PROPRIETARY

REVISION RECORD			
LTR	ECO NO:	APPROVED:	DATE:

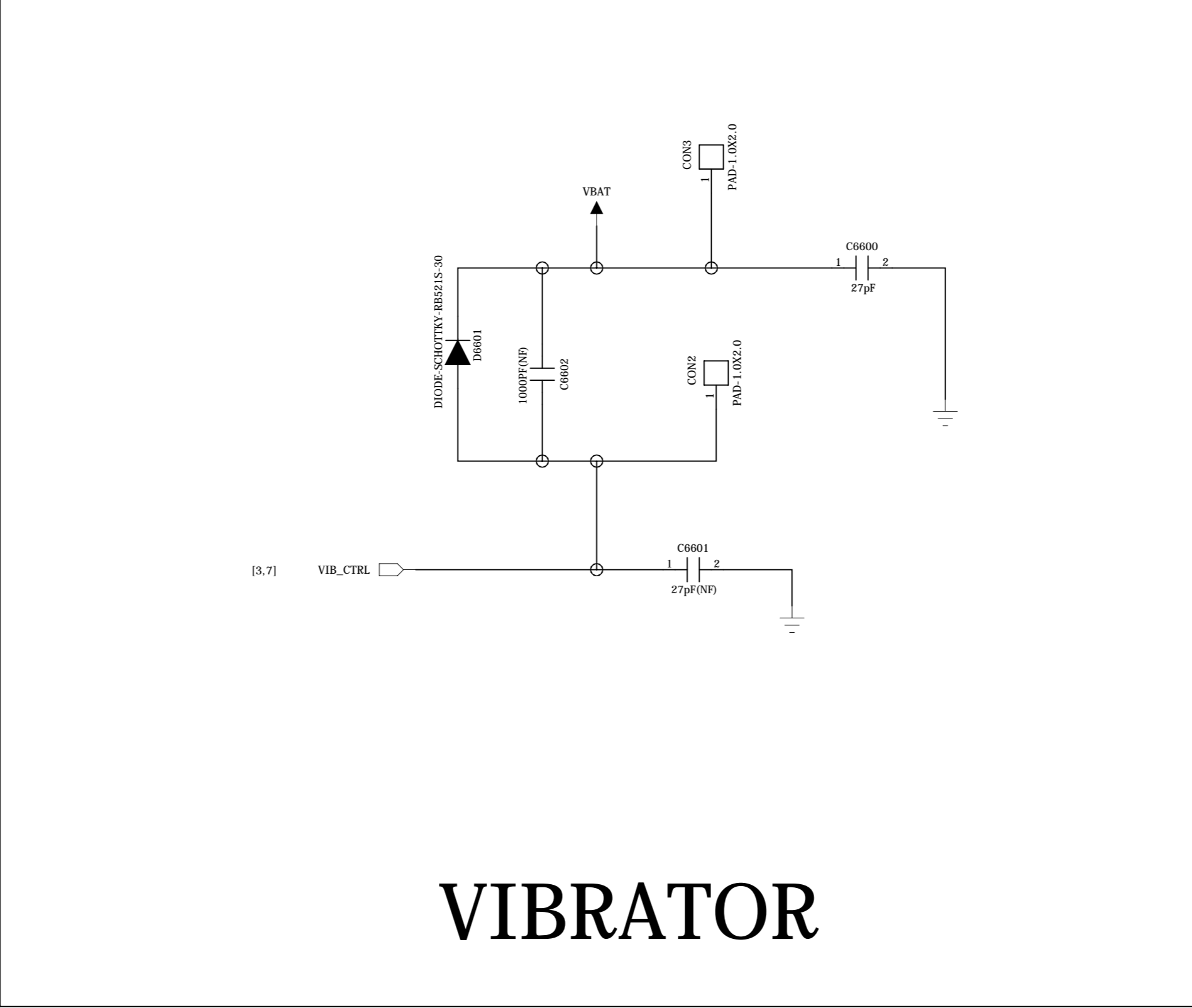

# VIBRATOR

TITLE & REV:  
**SC6610\_PLATFORM\_REFERENCE\_SCH\_V1.0.0.sch**

DOCUMENT NO.:  
**HW-SC6610-SCH-2011-0001**

DESIGNER: <b>Franks.Miao</b>	DATED: <b>2011-02-14</b>
EQN: <b>Robin.Zhang</b>	DATED: <b>2011-02-14</b>
APPROVED: <b>Guobing.Luan</b>	DATED: <b>2011-02-14</b>

DEPARTMENT: <b>Hardware RD.</b>
COMPANY: <b>Spreadtrum communications, Inc.</b>
CONFIDENTIAL AND PROPRIETARY

6

5

4

3

2

1

REVISION RECORD			
LTR	ECO NO:	APPROVED:	DATE:

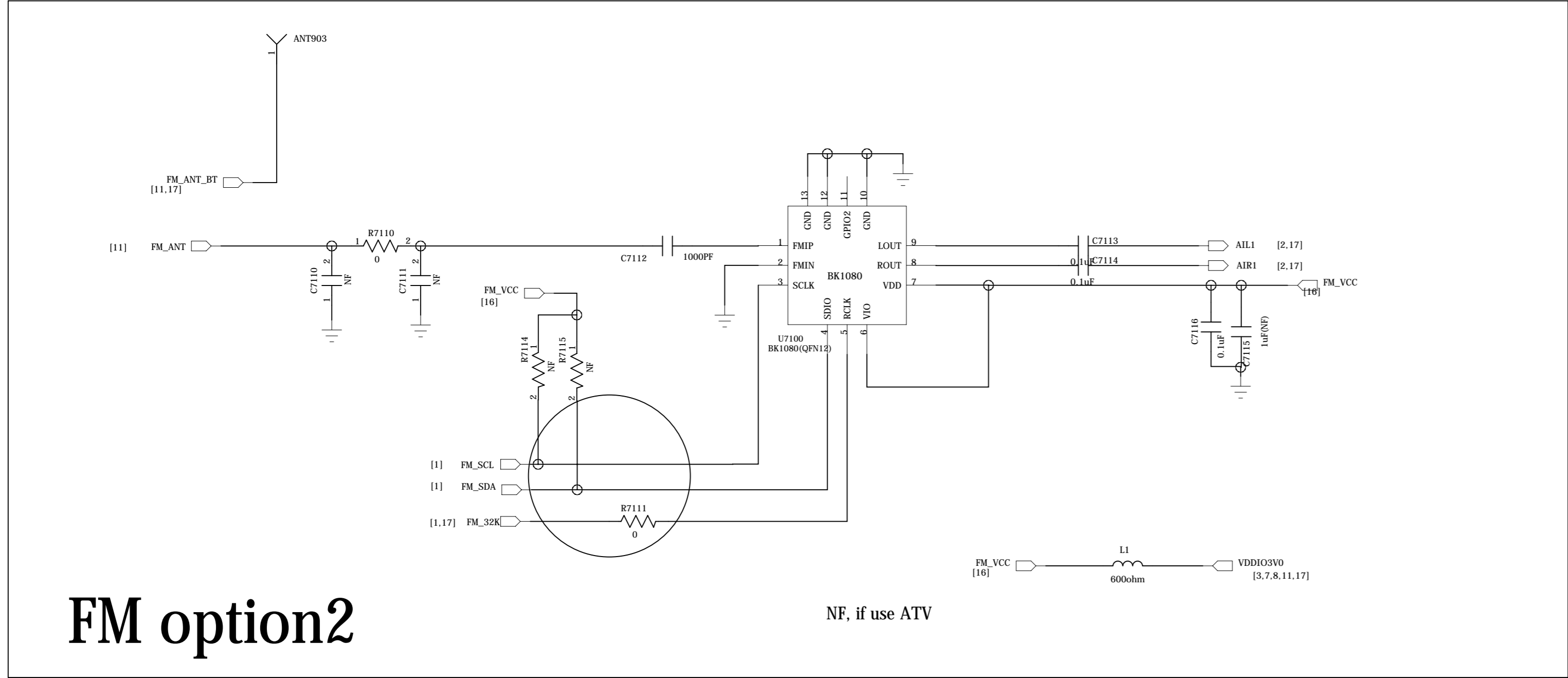

# FM option2

NF, if use ATV

D

D

C

C

B

B

A

A

TITLE & REV: SC6610_PLATFORM_REFERENCE_SCH_V1.0.0.sch		
DOCUMENT NO.: HW-SC6610-SCH-2011-0001		
DESIGNER: Franks.Miao	DATED: 2011-02-14	DEPARTMENT: Hardware RD.
EQA: Robin.Zhang	DATED: 2011-02-14	COMPANY: Spreadtrum communications, Inc.
APPROVED: Guobing.Luan	DATED: 2011-02-14	CONFIDENTIAL AND PROPRIETARY



REVISION RECORD			
LTR	ECO NO.	APPROVED:	DATE:

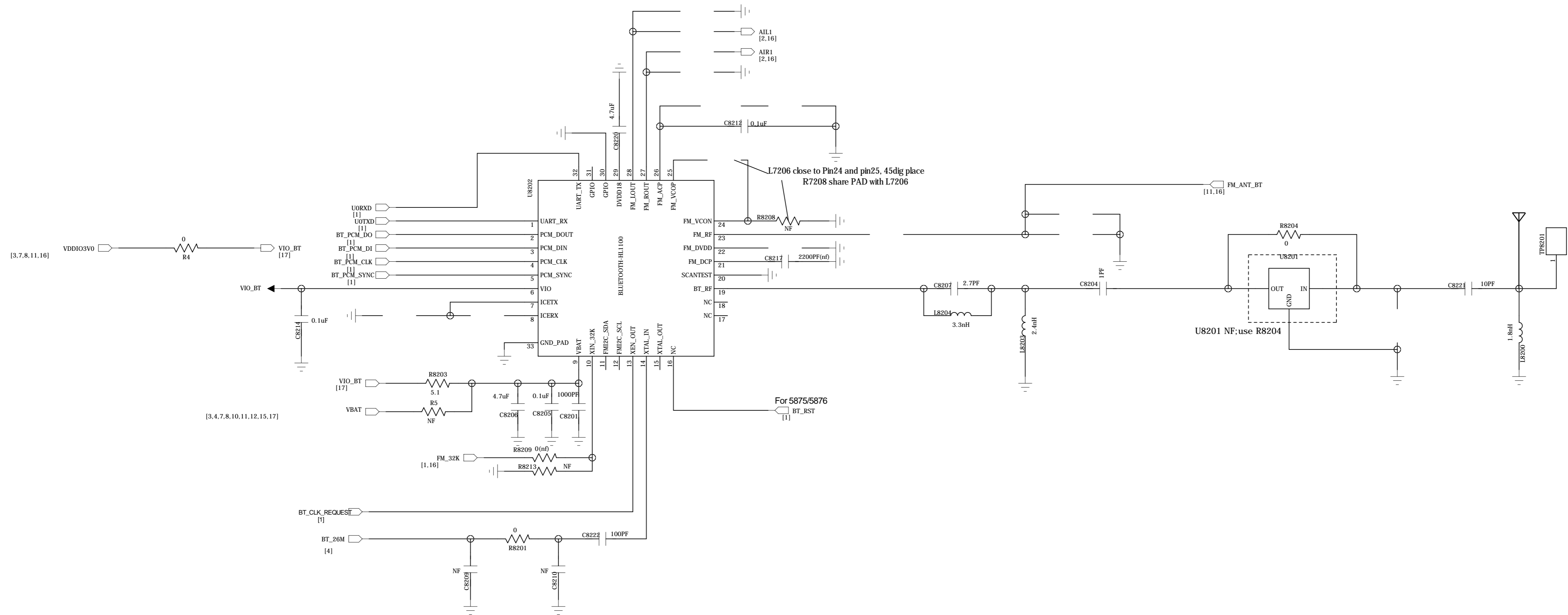

competition BOM, default is 1100

location	1100	1200	5875	5876	NOTE
C8200	NC	NC	4.7uF	4.7uF	
L8202	NC	NC	NC	NC	IDUT for DC/DC mode
R8209	NC	10k	0R	0R	32k is not use for 1100
R8213	NC	15k	NC	NC	
C8217	NC	2nF	0R	0R	
C8208	NC	1uF	0R	0R	
C8215	NC	1nF	NC	0R	
L8205	NC	NC	NC	100nH	
C8216	NC	NC	NC	24pF	
R8208	NC	NC	0R	0R	
L8206	NC	56nH	NC	NC	
R8206	NC	13K	NC	NC	
C8211	NC	1uF	NC	NC	
C8212	NC	100nF	0R	0R	
C8218	NC	100nF	NC	100nF	
C8219	NC	100nF	NC	100nF	
C8202	NC	22nF	NC	NC	
C8203	NC	22nF	NC	NC	
C8220	4.7uF	4.7uF	1uF	1uF	

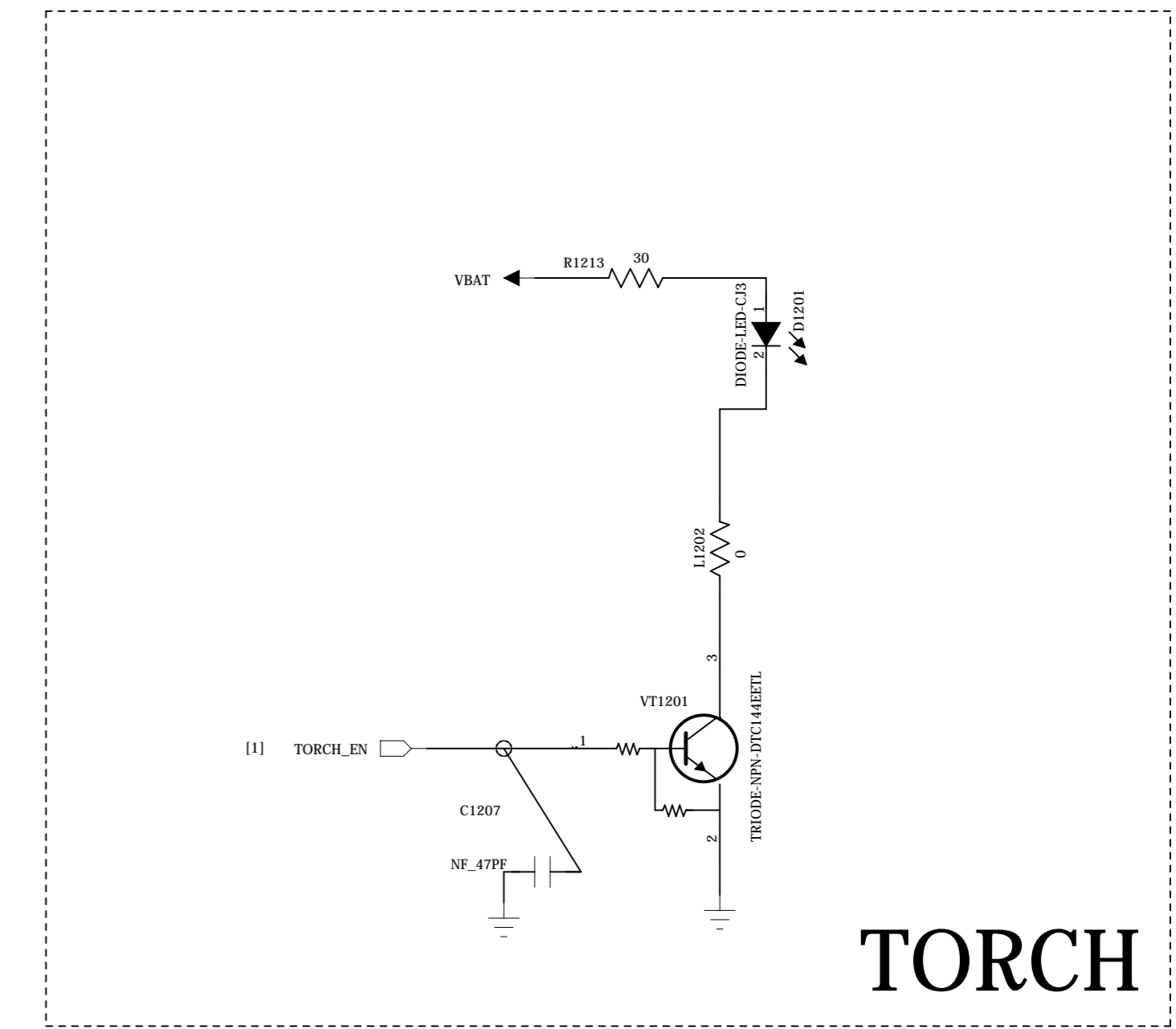

TITLE & REV: SC6610_PLATFORM_REFERENCE_SCH_V1.0.0.sch		
DOCUMENT NO.:		
DESIGNER:	DATED:	DEPARTMENT: Hardware RD.
EQA:	DATED:	COMPANY: Spreadtrum communications, Inc.
APPROVED:	DATED:	CONFIDENTIAL AND PROPRIETARY

REVISION RECORD			
LTR	ECO NO.	APPROVED:	DATE:

FIDUCIAL-MARK-1MM FIDUCIAL-MARK-1MM FIDUCIAL-MARK-1MM FIDUCIAL-MARK-1MM  
 MARK1 MARK2 MARK3 MARK4

MARK POINT

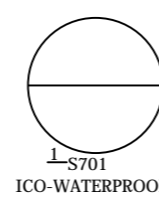

S701 ECO-WATERPROOF

FOR KEYPAD:

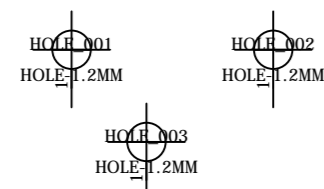

FOR FRAME BOLT:

HOLE

S710

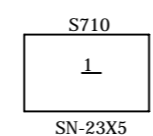

S710 L SN-2335

GROUND SYMBOLS

TITLE & REV: SC6610\_PLATFORM\_REFERENCE\_SCH\_V1.0.0.sch

DOCUMENT NO.:

DESIGNER:	DATED:	DEPARTMENT: Hardware RD.
EQA:	DATED:	COMPANY: Spreadtrum communications, Inc.
APPROVED:	DATED:	CONFIDENTIAL AND PROPRIETARY