

Soil Moisture Monitor with Time Display

Model: WH0291

Contents

1. Introduction	2
2. Get Started.....	2
2.1 Parts List	2
2.2 Soil Moisture Sensor Set Up.....	2
2.3 Display Console Set Up.....	3
2.3.1 Display Console Layout.....	5
3. Console Operation.....	6
3.1 Time setting mode	6
3.2 Custom mode	6
4. Function.....	10
5. Appendix.....	10
6. Specifications	11
7. FCC Statement.....	11
8. Warranty Information.....	13

1. Introduction

Thanks for your purchasing of the WH0291 Soil Moisture Monitor with Time Display. To ensure the best product performance, please read this manual and retain it for future reference.

2. Get Started

Note: Power up sequence can be performed in the order shown in this section: insert battery in the Soil Moisture Monitor(Receiver) first, then Soil Moisture Sensor(transmitter).

2.1 Parts List

One Soil Moisture Monitor (Receiver)

One Soil Moisture Sensor

One User Manual

2.2 Soil Moisture Sensor Set Up

1. Open the battery cap of the soil moisture sensor as shown in Figure 1

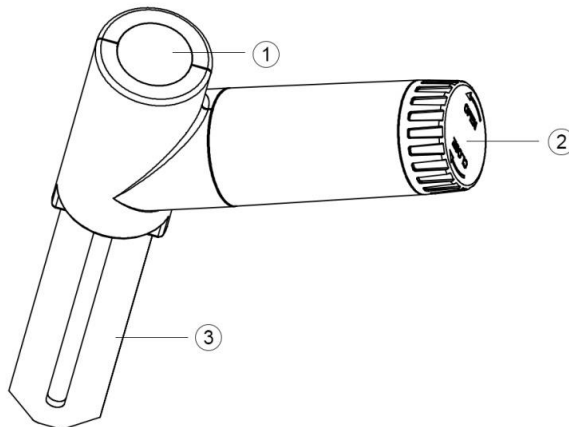

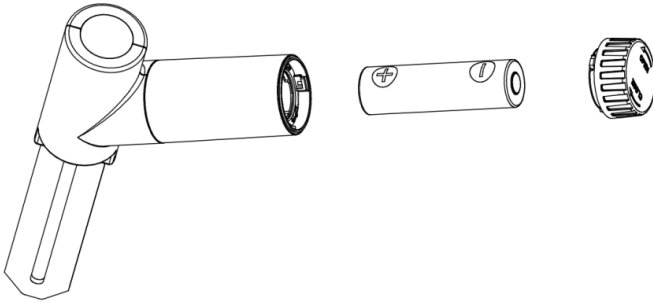

Figure 1

- 1 LED Indicator (RF transmission)
- 2 Battery Cap
- 3 Soil Moisture Sensor

2. Insert one AA battery.
3. After inserting the battery, the remote sensor LED indicator will light for 4 seconds, and then flash once per 70 second thereafter. Each time it flashes, the sensor is transmitting data.
4. Close the battery cap.
5. Insert the sensor totally into the soil of your potted plant.

2.3 Display Console Set Up

1. Remove the battery door on the back of the display, as shown in Figure 2. Insert one AA (alkaline, lithium or rechargeable) battery in the back of the display console.

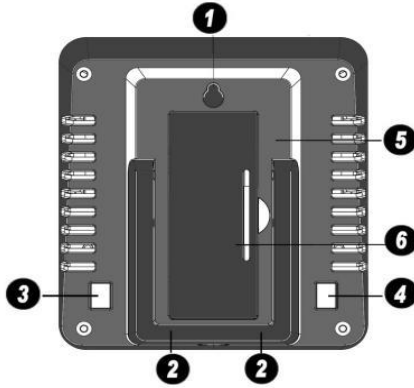
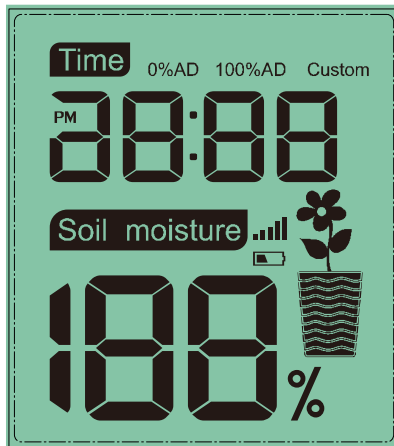

Figure 2

1. Integrated Hanging Hole
2. Tabletop Stand
3. ADD+ Button
4. Set Button
5. Battery Compartment
6. Battery Compartment Cover

All of the LCD segments will light up for a few seconds to verify all segments are operating properly.



Full Display

2. Replace the battery door and fold out the desk stand and place the console in the upright position.

The console will instantly display the default time (12:00). The soil moisture value will update on the display within a few minutes.

While in the search mode, the reception search icon  flash.

If the remote does not update, please contact our Customer Service for support.

2.3.1 Display Console Layout

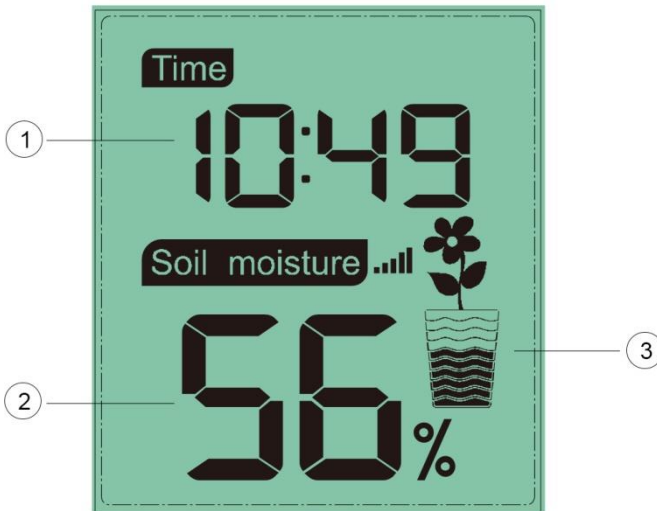

Figure 3

1. Time Display
2. Soil Moisture Value Display
3. Soil Moisture Grade Display

3. Console Operation

Note: The console has two program modes: Time setting mode and Custom mode.

If no operation for 20s, display will return to normal mode.

3.1 Time setting mode

Long press **SET** button to enter the time setting mode:

- a. Short press **ADD+**, choose between 12/24hr display
- b. Short press **SET**, step into Hour setting, Short press **ADD+** to adjust hour.
- c. Short press **SET**, step into Minute setting, Short press **ADD+** to adjust minute.

3.2 Custom mode

Custom OFF:

Moisture level is calculated based on default dry and wet definition:

Dry (0%AD) AD: 70

Wet (100% AD) AD: 500

Soil Moisture = $(\text{moisture AD} - 70) * 100\% / (500 - 70)$

Example: when sensor moisture AD is 310, calculated moisture is:
 $(310 - 70) * 100\% / (500 - 70) = 56\%$.

This is a fixed slope rate linear system.

Custom ON:

When pot soil at dry or wet condition is not giving the moisture sensor output value that is close to its default assumption, it will give inaccurate moisture level results. It is commonly happening with different soil type that gives very different output value at same moisture level condition. We introduced this custom mode to make this slope flexible so that it can match your soil type.

This becomes a variable slope rate linear system.

Adjusting principle:

0%AD is used to adjust for dry condition reading inconsistency.

When the displayed moisture readings are too high at dry soil condition, you could lower the slope rate by increasing the 0%AD value.

100%AD is used to adapt for wet condition reading inconsistency.

When the displayed moisture readings are too low at extremely wet soil condition, you could decrease the 100%AD value to fix it.

Please refer to the below example for better understanding.

For example:

When you use this product at the first time, please turn off the custom mode and test the product at the following two situations:

Situation One:

You watered your potted plant with enough water and the soil should be extremely wet, however the displayed moisture readings is much lower than 95%(e.g.70%).

Solution:

Enable custom mode, and enter 100%AD setting mode.

Hold the ADD+ button, till the 100%AD value reaches 1000 and roll over back to 80 (if your 0%AD is 70 and not changed). Now the 100%AD value will start from 80 while the displayed moisture readings will be calculated to be 100%.

Hold the ADD+ button till the moisture readings start to decrease until it shows 95%.

Record the 100%AD value for future use (when batteries changed).

Situation Two:

Your potted plant hasn't been watered for very long time and soil is extremely dry. When at this dry condition, displayed moisture readings are much higher than 10%(e.g.40%).

Solution:

Enable the custom mode and enter 0%AD setting mode.

Hold the ADD+ button till the moisture readings lowers to 10%(±).

Record the 0%AD value for future use (when batteries changed).

Note: The soil moisture sensor should be inserted totally into the soil for accurate result.

Operation Steps:

Short press **SET** after the time setting finished to select “Custom ON” and it will enter the custom setting mode:

a. Short press **ADD+** , enable/disable the custom function

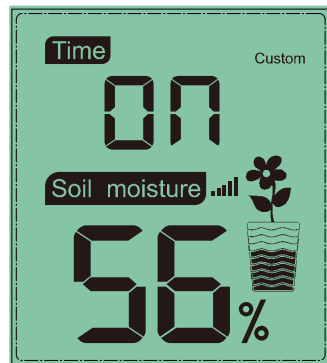
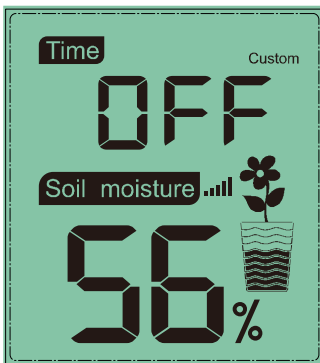

b. If enable the custom function, short press **ADD+** to adjust the 0%AD value from 70-200. The numbers will change rapidly when hold the **ADD+** button.

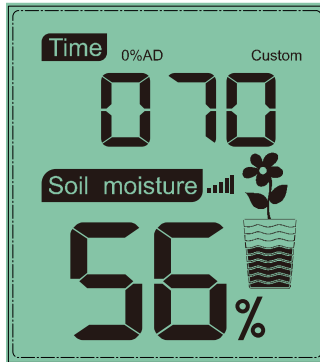

c. Short press **SET** to enter 100%AD setting mode. short press **ADD+** to adjust the 100%AD value from 0%AD+10 ~ 1000.

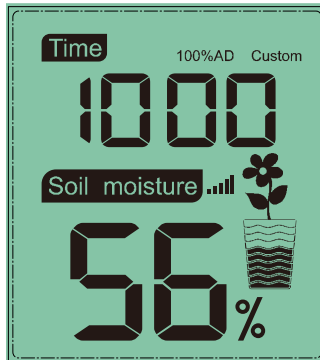

d. Short press **SET** to return to the normal mode.

There is no “-“ button available on this item. If you need to enter a value that is less than the value display, you need to keep press the “+” button until a rollover happens.

Important Note:

When adjusting, you should look at the displayed moisture readings change. Stop immediately when the expected moisture readings is displayed. If you keep pressing the button and the setting value will be increased beyond its sensing sensitive range, resulting in making the system much less sensitive. When this happens, please turn off

the custom mode and start over the custom calibration procedure.

4. Function

- 1) 12/24hr digital time display
- 2) Current soil moisture.
- 3) Every 70 second the unit will receive soil moisture sensor.
- 4) Wireless Signal Strength Indicator

During the synchronization, it will reduce one signal segment if it have not received the signal once from the transmitter. It will increase one signal segment if it has received the signal once.

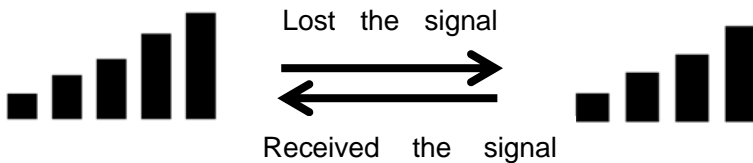

5. Appendix

Moisture grades display on the flower pot icon:

- Humidity range: 4%~0%: Display 0 grid moisture
- Humidity range: 14%~5%: Display 1 grid moisture
- Humidity range: 24%~15%: Display 2 grids moisture
- Humidity range: 34%~25%: Display 3 grids moisture
- Humidity range: 44%~35%: Display 4 grids moisture
- Humidity range: 54%~45%: Display 5 grids moisture
- Humidity range: 64%~55%: Display 6 grids moisture
- Humidity range: 74%~65%: Display 7 grids moisture
- Humidity range: 84%~75%: Display 8 grids moisture
- Humidity range: 94%~85%: Display 9 grids moisture
- Humidity range: 100%~95%: Display 10 grids moisture

6. Specifications

- Moisture Range:0~100%; Resolution: 1%
- 0%AD setting range:70~200; Initial value:70
- 100%AD setting range:0%AD+10~1000; Initial value:500
- Frequency: 433 MHz
- Update Rate: 70 seconds
- Power Consumption: MIN 1Year battery life.
Base station (display console) : 1 x AA battery(not included)
Remote sensor : 1 x AA battery(not included)

7. FCC Statement

Statement according to FCC part 15.19:

This device complies with part 15 of the FCC rules. Operation is subject to the following two conditions:

1. This device may not cause harmful interference.
2. This device must accept any interference received, including interference that may cause undesired operation.

Statement according to FCC part 15.21:

Any changes or Modifications not expressly approved by this company could void the user's authority to operate the equipment.

Statement according to FCC part 15.105:

NOTE: This equipment has been tested and found to comply with the limits for a Class B digital device, pursuant to Part 15 of the FCC Rules. These limits are designed to provide reasonable protection against harmful interference in a residential installation. This equipment generates, uses and can radiate radio frequency energy and, if not installed and used in accordance with the instructions, may cause harmful interference to radio communications.

However, there is no guarantee that interference will not occur in a particular installation. If this equipment does cause harmful interference to radio or television reception, which can be determined by turning the equipment off and on, the user is encouraged to try to correct the interference by one or more of the following measures:

- Reorient or relocate the receiving antenna.
- Increase the separation between the equipment and receiver.
- Connect the equipment into an outlet on a circuit different from that to which the receiver is connected.
- Consult the dealer or an experienced radio/TV technician for help.

This device complies with FCC radiation exposure limits set forth for an uncontrolled environment and it also complies with Part 15 of the FCC RF Rules. This equipment must be installed and operated in accordance with provided instructions and the antenna(s) used for this transmitter must be installed to provide a separation distance of at least 20 cm from all persons and must not be co-located or operating in conjunction with any other antenna or transmitter. End-users and installers must be provided with antenna installation instructions and consider removing the no-collocation statement.



8. Warranty Information

We disclaim any responsibility for any technical error or printing error, or their consequences.

All trademarks and patents are recognized.

We provide a 1-year limited warranty on this product against manufacturing defects in materials and workmanship.

This limited warranty begins on the original date of purchase, is valid only on products purchased and only to the original purchaser of this product. To receive warranty service, the purchaser must contact us for problem determination and service procedures.

This warranty covers only actual defects within the product itself, and does not cover the cost of installation or removal from a fixed installation, normal set-up or adjustments, claims based on misrepresentation by the seller or performance variations resulting from installation-related circumstances.