

ELECTROMAGNETIC EMISSION COMPLIANCE REPORT FOR LICENSED TRANSMITTER

Test Report No. : W17DR-D037
AGR No. : A17NA-103
Applicant : Suntech International Ltd.
Address : B-1506, Great Valley, 32, 9-Gil, Digital-Ro, Geumcheon-Gu, Seoul, 08512, South Korea
Manufacturer : Suntech International Ltd.
Address : B-1506, Great Valley, 32, 9-Gil, Digital-Ro, Geumcheon-Gu, Seoul, 08512, South Korea
Type of Equipment : Vehicle Tracker
FCC ID. : WA2ST340U
Model Name : ST340U
Serial number : N/A
Total page of Report : 53 pages (including this page)
Date of Incoming : November 07, 2017
Date of issue : December 18, 2017

SUMMARY

The equipment complies with the regulation; **FCC Part 22 Subpart H, Part 24 Subpart E**

This test report only contains the result of a single test of the sample supplied for the examination.

It is not a generally valid assessment of the features of the respective products of the mass-production.

Reviewed by:



Jae-Ho Lee / Chief Engineer
ONETECH Corp.

Approved by:

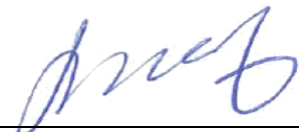

Keun-Young, Choi / Vice President
ONETECH Corp.

CONTENTS

	PAGE
1. VERIFICATION OF COMPLIANCE	6
2. TEST SUMMARY.....	7
2.1 TEST ITEMS AND RESULTS	7
2.2 ADDITIONS, DEVIATIONS, EXCLUSIONS FROM STANDARDS.....	7
2.3 RELATED SUBMITTAL(S) / GRANT(S)	7
2.4 PURPOSE OF THE TEST	7
2.5 TEST METHODOLOGY.....	7
2.6 TEST FACILITY.....	8
3. GENERAL INFORMATION.....	9
3.1 PRODUCT DESCRIPTION.....	9
3.2 EMISSION DESIGNATOR	9
4. EUT MODIFICATIONS.....	10
5. SYSTEM TEST CONFIGURATION	11
5.1 JUSTIFICATION.....	11
5.2 PERIPHERAL EQUIPMENT	11
5.3 MODE OF OPERATION DURING THE TEST	11
5.4 CONFIGURATION OF TEST SYSTEM.....	12
6. PRELIMINARY TEST	13
6.1 AC POWER LINE CONDUCTED EMISSIONS TESTS.....	13
6.2 GENERAL RADIATED EMISSIONS TESTS	13
7. CONDUCTED OUTPUT POWER	14
7.1 OPERATING ENVIRONMENT	14
7.2 TEST SET-UP	14
7.3 TEST EQUIPMENT USED.....	14
7.4 TEST DATA.....	15
8. EFFECTIVE RADIATED POWER	16
8.1 OPERATING ENVIRONMENT	16
8.2 TEST SET-UP	16
8.3 TEST EQUIPMENT USED.....	16
8.4 TEST DATA.....	17
9. EQUIVALENT ISOTROPIC RADIATED POWER	18

9.1 OPERATING ENVIRONMENT	18
9.2 TEST SET-UP	18
9.3 TEST EQUIPMENT USED	18
9.4 TEST DATA	19
10. RADIATED SPURIOUS EMISSIONS	20
10.1 OPERATING ENVIRONMENT	20
10.2 TEST SET-UP	20
10.3 TEST EQUIPMENT USED	21
10.4 TEST DATA	22
10.4.1 Test data for GSM850	22
10.4.2 Test data for GSM1900	23
11. PEAK-TO-AVERAGE RATIO	24
11.1 OPERATING ENVIRONMENT	24
11.2 TEST SET-UP	24
11.3 TEST EQUIPMENT USED	25
11.4 TEST DATA	26
12. OCCUPIED BANDWIDTH	27
12.1 OPERATING ENVIRONMENT	27
12.2 TEST SET-UP	27
12.3 TEST EQUIPMENT USED	27
12.4 TEST DATA	28
12.4.1 Test data for GSM850	28
12.4.2 Test data for GSM1900	33
13. CONDUCTED SPURIOUS EMISSIONS	38
13.1 OPERATING ENVIRONMENT	38
13.2 TEST SET-UP	38
13.3 TEST EQUIPMENT USED	38
13.4 TEST DATA	39
13.4.1 Test data for GSM850	39
13.4.2 Test data for GSM1900	42
14. FREQUENCY STABILITY / VARIATION OF AMBIENT TEMPERATURE	47
14.1 OPERATING ENVIRONMENT	47
14.2 TEST SET-UP	47
14.3 TEST EQUIPMENT USED	47
14.4 TEST DATA	48
14.4.1 Test data for GSM850	48

14.4.2 Test data for GSM1900.....48

15. CONDUCTED EMISSION TEST.....**49**

15.1 OPERATING ENVIRONMENT49

15.2 TEST SET-UP49

15.3 TEST EQUIPMENT USED.....49

15.4 TEST DATA.....50

15.4.1 Test data for GSM850.....50

15.4.2 Test data for GSM1900.....52

Revision History

Issued Report No.	Issued Date	Revisions	Effect Section
W17DR-D037	December 18, 2017	Initial Issue	All

1. VERIFICATION OF COMPLIANCE

Applicant : Suntech International Ltd.
 Address : B-1506, Great Valley, 32, 9-Gil, Digital-Ro, Geumcheon-Gu, Seoul, 08512, South Korea
 Contact Person : Yohan Kim / Manager
 Telephone No. : +82-2-6327-5661
 FCC ID : WA2ST340U
 Model Name : ST340U
 Serial Number : N/A
 Date : December 18, 2017

EQUIPMENT CLASS	PCB-PCS Licensed Transmitter
EQUIPMENT DESCRIPTION	Vehicle Tracker
THIS REPORT CONCERNS	Original Grant
MEASUREMENT PROCEDURES	ANSI/TIA-603-D-2010
TYPE OF EQUIPMENT TESTED	Pre-Production
KIND OF EQUIPMENT AUTHORIZATION REQUESTED	Certification
EQUIPMENT WILL BE OPERATED UNDER FCC RULES PART(S)	FCC Part 22 Subpart H, Part 24 Subpart E
Modifications on the Equipment to Achieve Compliance	None
Final Test was Conducted On	3 m Semi Anechoic Chamber

-. The above equipment was tested by ONETECH Corp. for compliance with the requirement set forth in the FCC Rules and Regulations. This said equipment in the configuration described in this report, shows the maximum emission levels emanating from equipment are within the compliance requirements.

2. TEST SUMMARY

2.1 Test items and results

SECTION	TEST ITEMS	RESULTS
2.1049	Occupied Bandwidth	Met the Limit / PASS
2.1051, 22.917(a), 24.238(a)	Band Edge / Spurious and Harmonic Emissions at Antenna Termianl	Met the Limit / PASS
2.1046	Conducted Output Power	Met the Limit / PASS
24.232(d)	Peak-to-Average Ratio	Met the Limit / PASS
2.1055, 22.355	Frequency stability / Variation of ambient temperature	Met the Limit / PASS
24.235		Met the Limit / PASS
22.913(a)(2)	Effective Radiated Power Equivalent Isotropic Radiated Power	Met the Limit / PASS
24.232(c)	Equivalent Isotropic Radiated Power	Met the Limit / PASS
2.1053, 22.917(a), 24.238(a)	Radiated Spurious and Harmonic Emissions	Met the Limit / PASS

2.2 Additions, deviations, exclusions from standards

No additions, deviations or exclusions have been made from standard.

2.3 Related Submittal(s) / Grant(s)

Original submittal only

2.4 Purpose of the test

To determine whether the equipment under test fulfills the requirements of the regulation stated in FCC Part 22 Subpart H, Part 24 Subpart E.

2.5 Test Methodology

Both conducted and radiated testing was performed according to the procedures in ANSI/TIA-603-D-2010. Radiated testing was performed at a distance of 3 m from EUT to the antenna.

2.6 Test Facility

The Onetech Corp. has been designated to perform equipment testing in compliance with ISO/IEC 17025.

The Electromagnetic compatibility measurement facilities are located at 43-14, Jinsaegol-gil, Chowol-eup, Gwangju-si, Gyeonggi-do, 12735, Korea

-. Site Filing:

VCCI (Voluntary Control Council for Interference) – Registration No. R-4112/ C-14617/ G-10666 / T-1842

IC (Industry Canada) – Registration No. Site# 3736A-3

-. Site Accreditation:

KOLAS (Korea Laboratory Accreditation Scheme) - Accreditation NO. KT085

FCC (Federal Communications Commission) - Accreditation No. KR0013

RRA (Radio Research Agency) – Designation No. KR0013

3. GENERAL INFORMATION

3.1 Product Description

The Suntech International Ltd., Model ST340U (referred to as the EUT in this report) is a Vehicle Tracker. Product specification information described herein was obtained from product data sheet or user’s manual.

DEVICE TYPE	Vehicle Tracker		
OPERATING FREQUENCY	GSM850 / GSM850 EDGE	TX	824.2 MHz ~ 848.8 MHz
		RX	869.2 MHz ~ 893.8 MHz
	GSM1900 / GSM1900 EDGE	TX	1 850.2 MHz ~1 909.8 MHz
		RX	1 930.2 MHz ~ 1 989.8 MHz
MAX. RF OUTPUT POWER	GSM850	32.53 dBm	
	GSM850 EDGE	32.43 dBm	
	GSM1900	29.46 dBm	
	GSM1900 EDGE	29.15 dBm	
Effective Radiated Power	GSM850	27.99 dBm	
	GSM850 EDGE	27.80 dBm	
Equivalent Isotropic Radiated Power	GSM1900	23.53 dBm	
	GSM1900 EDGE	23.23 dBm	
ANTENNA TYPE	INTENNA		
ANTENNA GAIN	GSM850	-1.2 dBi	
	GSM1900	-1.2 dBi	
List of each Osc. or crystal Freq.(Freq. >= 1 MHz)	26 MHz		

3.2 Emission Designator

GSM Emission Designator	EDGE Emission Designator
Emission Designator = 249KGXW GSM BW = 249 kHz G = Phase Modulation X = Cases not otherwise covered W = Combination (Audio/Data)	Emission Designator = 249KG7W GSM BW = 249 kHz G = Phase Modulation 7 = Quantized/Digital Info W = Combination (Audio/Data)

3.3 Alternative type(s)/model(s); also covered by this test report.

-. None

4. EUT MODIFICATIONS

-. None

5. SYSTEM TEST CONFIGURATION

5.1 Justification

This device was configured for testing in a typical way as a normal customer is supposed to be used. During the test, the following components were installed inside of the EUT.

DEVICE TYPE	MANUFACTURER	MODEL/PART NUMBER	FCC ID
Main Board	N/A	N/A	N/A
Battery	YUILSYSTEM	PD1706	N/A
Antenna	N/A	N/A	N/A

5.2 Peripheral equipment

Defined as equipment needed for correct operation of the EUT, but not considered as tested:

Model	Manufacturer	Description	Connected to
N/A	N/A	N/A	N/A

5.3 Mode of operation during the test

The EUT was received signal form signal generator and then each modulation was configured for maximum signal gain and bandwidth. The EUT was operated in a manner representative of the typical usage of the equipment. During all testing, system components were manipulated within the confines of typical usage to maximize each emission. The applicant does not supply antenna(s) with the system, so the dummy loads were connected to the RF output ports on the EUT for radiated spurious emission testing.

For the above testing, following frequencies per channel were selected for each modulation.

- Mode

Modulation	Channel	Frequency
GSM850	Low	824.2
	Middle	836.6
	High	848.8
GSM1900	Low	1 850.2
	Middle	1 880.0
	High	1 909.8

5.4 Configuration of Test System

Line Conducted Test: The EUT is connected wirelessly through the Communication Unit. All supporting equipments were connected to another LISN. Preliminary Power line Conducted Emission test was performed by using the procedure in ANSI C63.10: 2013 to determine the worse operating conditions.

Radiated Emission Test: Preliminary radiated emissions test were conducted using the procedure in ANSI C63.10: 2013 to determine the worse operating conditions. Final radiated emission tests were conducted at 3 m Semi Anechoic Chamber.

The turntable was rotated through 360 degrees and the EUT was tested by positioned three orthogonal planes to obtain the highest reading on the field strength meter. Once maximum reading was determined, the search antenna was raised and lowered in both vertical and horizontal polarization.

6. PRELIMINARY TEST

6.1 AC Power line Conducted Emissions Tests

During Preliminary Test, the following operating mode was investigated.

Operation Mode	The Worse operating condition (Please check one only)
Transmitting Mode	X

6.2 General Radiated Emissions Tests

During Preliminary Test, the following operating mode was investigated.

Operation Mode	The Worse operating condition (Please check one only)
Transmitting Mode	X

7. CONDUCTED OUTPUT POWER

7.1 Operating environment

Temperature : 23 °C
 Relative humidity : 44 % R.H.

7.2 Test set-up

Conducted Output Power is tested in accordance with KDB971168 D01 Power Meas License Digital Systems v03, October 27, 2017, Section 5.2.

A base station simulator was used to establish communication with the EUT, and Spectrum analyzer was used for test results. This device was tested under all configurations and the highest power is reported. Conducted Output Powers of EUT are reported below.

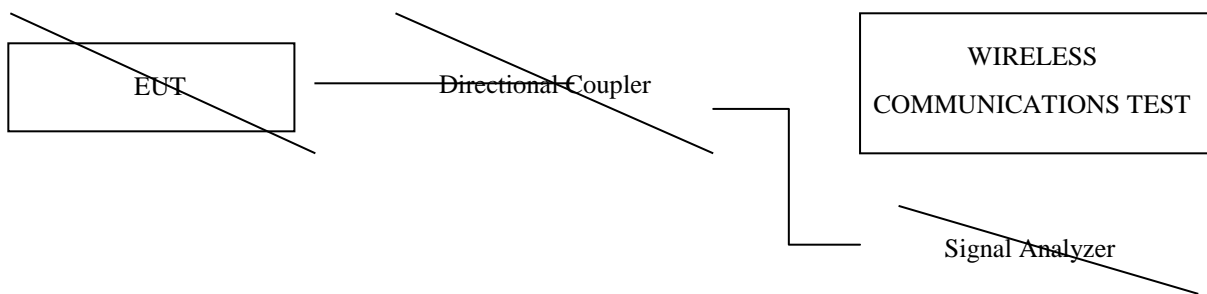

7.3 Test equipment used

Model Number	Manufacturer	Description	Serial Number	Last Cal.
■ - FSV30	Rohde & Schwarz	Signal Analyzer	101199	Apr. 05, 2017 (1Y)
■ - E5515C	Agilent	WIRELESS COMMUNICATIONS TEST SET	MY48365015	Jun. 08, 2017 (1Y)

All test equipment used is calibrated on a regular basis.

7.4 Test data

-. Test Date : November 20, 2017

-. Test Result : Pass

BAND	CHANNEL	GSM/GPRS (dBm)	EDGE (dBm)
GSM850	Low	32.53	32.43
	Middle	32.51	32.39
	High	32.46	32.40
GSM1900	Low	29.46	29.13
	Middle	29.46	29.12
	High	29.26	29.15



Tested by: Min-Gu Ji / Assistant Manager

8. EFFECTIVE RADIATED POWER

8.1 Operating environment

Temperature : 23 °C
 Relative humidity : 44 % R.H.

8.2 Test set-up

The EUT and measurement equipment were set up as shown in the diagram below.

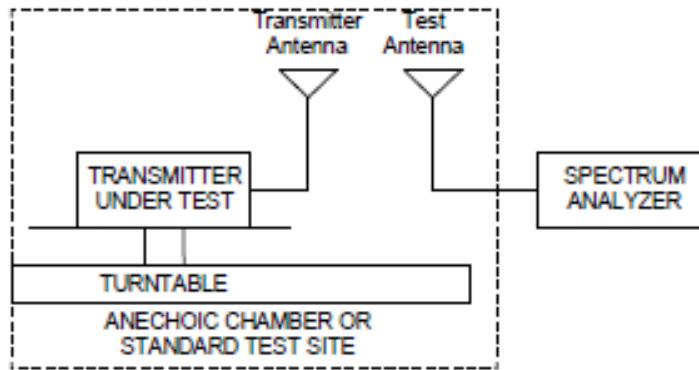

8.3 Test equipment used

Model Number	Manufacturer	Description	Serial Number	Last Cal. (Interval)
<input type="checkbox"/> - ESCI	Rohde & Schwarz	EMI Test Receiver	101012	Oct. 27, 2017 (1Y)
<input checked="" type="checkbox"/> - ESR	Rohde & Schwarz	EMI Test Receiver	101470	Oct. 27, 2017 (1Y)
<input type="checkbox"/> - FSP	Rohde & Schwarz	Spectrum Analyzer	100017	Sep. 04, 2017 (1Y)
<input checked="" type="checkbox"/> - 310N	Sonoma Instrument	AMPLIFIER	312544	Apr. 04, 2017 (1Y)
<input checked="" type="checkbox"/> - FSV30	Rohde & Schwarz	Signal Analyzer	101200	Oct. 26, 2017 (1Y)
<input checked="" type="checkbox"/> - 83051A	Agilent	Microwave System Preamplifier	3950M00201	Apr. 06, 2017 (1Y)
<input type="checkbox"/> - SCU-18	Rohde & Schwarz	Pre-Amplifier	102346	Oct. 24, 2017 (1Y)
<input checked="" type="checkbox"/> - MA-4000XPET	Innco Systems GmbH	Antenna Master	MA4000/509	N/A
<input type="checkbox"/> - HD100	HD GmbH	Position Controller	N/A	N/A
<input checked="" type="checkbox"/> - DT3000-3t	Innco Systems GmbH	Turn Table	N/A	N/A
<input type="checkbox"/> - FMZB 1513	Schwarzbeck	LOOP ANTENNA	1513-235	Jun. 10, 2016 (2Y)
<input checked="" type="checkbox"/> - VULB9163	Schwarzbeck	TRILOG Broadband Antenna	9163-255	May 20, 2016 (2Y)
<input checked="" type="checkbox"/> - BBHA9120D	Schwarzbeck	Horn Antenna	BBHA9120D295	Aug. 16, 2017 (2Y)
<input checked="" type="checkbox"/> - BBHA9170	Schwarzbeck	Horn Antenna	BBHA91700179	Jul. 28, 2017 (2Y)
<input type="checkbox"/> - SCU40A	Rohde & Schwarz	Pre-Amplifier	100436	Apr. 04, 2017 (1Y)

All test equipment used is calibrated on a regular basis.

8.4 Test data

-. Test Date : November 20, 2017

-. Test Result : Pass

Frequency (MHz)	S/A Reading (dBm)	S/G Reading (dBm)	Ant. Pol. (H/V)	Ant Gain (dBd)	Cable Loss (dB)	Total (dBm)	Total (mW)	Limit (mW)
Test Data for GSM850								
824.2	12.20	24.81	H	-0.48	1.75	23.55	226.23	7 000.00
836.6	12.49	27.26	H	-0.43	1.76	25.94	392.30	7 000.00
848.8	12.55	29.24	H	-0.53	1.77	27.99	629.67	7 000.00
Test Data for EDGE								
848.8	10.24	29.05	H	-0.53	1.77	27.80	602.72	7 000.00

Remark: EDGE mode is measured only at the channel with the highest power.

“H”: Horizontal, “V”: Vertical



Tested by: Min-Gu Ji / Assistant Manager

9. EQUIVALENT ISOTROPIC RADIATED POWER

9.1 Operating environment

Temperature : 23 °C
 Relative humidity : 44 % R.H.

9.2 Test set-up

The EUT and measurement equipment were set up as shown in the diagram below.

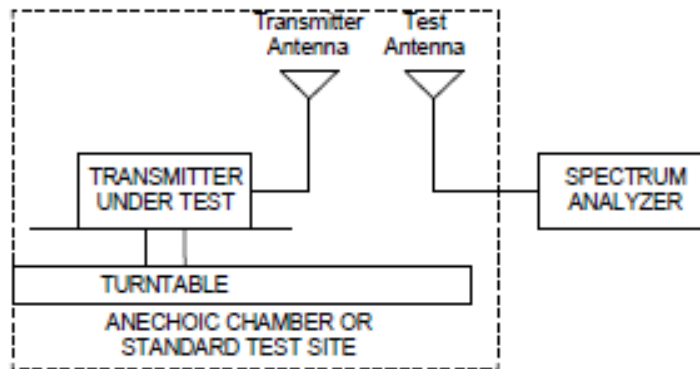

9.3 Test equipment used

Model Number	Manufacturer	Description	Serial Number	Last Cal. (Interval)
<input type="checkbox"/> - ESCI	Rohde & Schwarz	EMI Test Receiver	101012	Oct. 27, 2017 (1Y)
<input checked="" type="checkbox"/> - ESR	Rohde & Schwarz	EMI Test Receiver	101470	Oct. 27, 2017 (1Y)
<input type="checkbox"/> - FSP	Rohde & Schwarz	Spectrum Analyzer	100017	Sep. 04, 2017 (1Y)
<input checked="" type="checkbox"/> - 310N	Sonoma Instrument	AMPLIFIER	312544	Apr. 04, 2017 (1Y)
<input checked="" type="checkbox"/> - FSV30	Rohde & Schwarz	Signal Analyzer	101200	Oct. 26, 2017 (1Y)
<input checked="" type="checkbox"/> - 83051A	Agilent	Microwave System Preamplifier	3950M00201	Apr. 06, 2017 (1Y)
<input type="checkbox"/> - SCU-18	Rohde & Schwarz	Pre-Amplifier	102346	Oct. 24, 2017 (1Y)
<input checked="" type="checkbox"/> - MA-4000XPET	Innco Systems GmbH	Antenna Master	MA4000/509	N/A
<input type="checkbox"/> - HD100	HD GmbH	Position Controller	N/A	N/A
<input checked="" type="checkbox"/> - DT3000-3t	Innco Systems GmbH	Turn Table	N/A	N/A
<input type="checkbox"/> - FMZB 1513	Schwarzbeck	LOOP ANTENNA	1513-235	Jun. 10, 2016 (2Y)
<input checked="" type="checkbox"/> - VULB9163	Schwarzbeck	TRILOG Broadband Antenna	9163-255	May 20, 2016 (2Y)
<input checked="" type="checkbox"/> - BBHA9120D	Schwarzbeck	Horn Antenna	BBHA9120D295	Aug. 16, 2017 (2Y)
<input checked="" type="checkbox"/> - BBHA9170	Schwarzbeck	Horn Antenna	BBHA91700179	Jul. 28, 2017 (2Y)
<input type="checkbox"/> - SCU40A	Rohde & Schwarz	Pre-Amplifier	100436	Apr. 04, 2017 (1Y)

All test equipment used is calibrated on a regular basis.

9.4 Test data

-. Test Date : November 20, 2017

-. Test Result : Pass

Frequency (MHz)	S/A Reading (dBm)	S/G Reading (dBm)	Ant. Pol. (H/V)	Ant Gain (dBi)	Cable Loss (dB)	Total (dBm)	Total (mW)	Limit (W)
Test Data for GSM1900								
1 850.20	3.88	13.67	H	10.10	2.66	21.12	129.40	2.00
1 880.00	7.04	15.38	H	10.24	2.69	22.93	196.52	2.00
1 909.80	8.79	15.87	H	10.38	2.72	23.53	225.49	2.00
Test Data for EDGE								
1 909.8	6.29	15.57	H	10.38	2.72	23.23	210.44	2.00

Remark: EDGE mode is measured only at the channel with the highest power.

“H”: Horizontal, “V”: Vertical



Tested by: Min-Gu Ji / Assistant Manager

10. RADIATED SPURIOUS EMISSIONS

10.1 Operating environment

Temperature : 23 °C
 Relative humidity : 48 % R.H.

10.2 Test set-up

Radiated emission measurements are performed in the Semi-Anechoic chamber. The equipment under test is placed on a non-conductive table 3-meters away from the receive antenna in accordance with ANSI/TIA- 603-D-2010 Clause 2.2.17. The turntable is rotated through 360°, and the receiving antenna scans in order to determine the level of the maximized emission. The level and position of the maximized emission is recorded with the spectrum analyzer using RMS detector. A vertically polarized half-wave dipole is then substituted in place of the EUT. For emissions above 1GHz, a horn antenna is substituted in place of the EUT. The substitute antenna is driven by a signal generator and the previously recorded signal was duplicated.

The power is calculated by the following formula;

$$Pd(\text{dBm}) = Pg(\text{dBm}) - \text{cable loss (dB)} + \text{antenna gain (dB)}$$

Where: Pd is the dipole equivalent power and Pg is the generator output power into the substitution antenna.

The maximum EIRP is calculated by adding the forward power to the calibrated source plus its appropriate gain value. These steps are repeated with the receiving antenna in both vertical and horizontal polarization. the difference between the gain of the horn and an isotropic antenna are taken into consideration

Radiated spurious emissions

1. Frequency Range : 9 kHz ~ 10th Harmonics of highest channel fundamental frequency.
 2. The EUT was setup to maximum output power. The 100 kHz RBW was used to scan from 30 MHz to 1 GHz.
- Also, the 1 MHz RBW was used to scan from 1 GHz to 10 GHz(GSM850) or 20 GHz(GSM1900). The high, low and a middle channel were tested for out of band measurements.

10.3 Test equipment used

	Model Number	Manufacturer	Description	Serial Number	Last Cal. (Interval)
<input type="checkbox"/>	ESCI	Rohde & Schwarz	EMI Test Receiver	101012	Oct. 27, 2017 (1Y)
<input checked="" type="checkbox"/>	ESR	Rohde & Schwarz	EMI Test Receiver	101470	Oct. 27, 2017 (1Y)
<input type="checkbox"/>	FSP	Rohde & Schwarz	Spectrum Analyzer	100017	Sep. 04, 2017 (1Y)
<input checked="" type="checkbox"/>	310N	Sonoma Instrument	AMPLIFIER	312544	Apr. 04, 2017 (1Y)
<input checked="" type="checkbox"/>	FSV30	Rohde & Schwarz	Signal Analyzer	101200	Oct. 26, 2017 (1Y)
<input checked="" type="checkbox"/>	83051A	Agilent	Microwave System Preamplifier	3950M00201	Apr. 06, 2017 (1Y)
<input type="checkbox"/>	SCU-18	Rohde & Schwarz	Pre-Amplifier	102346	Oct. 24, 2017 (1Y)
<input checked="" type="checkbox"/>	MA-4000XPET	Innco Systems GmbH	Antenna Master	MA4000/509	N/A
<input type="checkbox"/>	HD100	HD GmbH	Position Controller	N/A	N/A
<input checked="" type="checkbox"/>	DT3000-3t	Innco Systems GmbH	Turn Table	N/A	N/A
<input type="checkbox"/>	FMZB 1513	Schwarzbeck	LOOP ANTENNA	1513-235	Jun. 10, 2016 (2Y)
<input checked="" type="checkbox"/>	VULB9163	Schwarzbeck	TRILOG Broadband Antenna	9163-255	May 20, 2016 (2Y)
<input checked="" type="checkbox"/>	BBHA9120D	Schwarzbeck	Horn Antenna	BBHA9120D295	Aug. 16, 2017 (2Y)
<input checked="" type="checkbox"/>	BBHA9170	Schwarzbeck	Horn Antenna	BBHA91700179	Jul. 28, 2017 (2Y)
<input type="checkbox"/>	SCU40A	Rohde & Schwarz	Pre-Amplifier	100436	Apr. 04, 2017 (1Y)

All test equipment used is calibrated on a regular basis.

10.4 Test data

10.4.1 Test data for GSM850

- . Test Date : December 03, 2017
- . Resolution bandwidth : 1 MHz for Peak and Average Mode for the emissions in restricted band,
100 kHz for Peak Mode for the emissions outside restricted band
- . Video bandwidth : 3 MHz for Peak Mode and Average Mode
300 kHz for Peak Mode for the emissions outside restricted band
- . Detector : RMS
- . Measurement distance : 3 m
- . Result : PASSED

Frequency (GHz)	S/A Reading (dBμV)	Ant. Pol. (H/V)	S/G Reading (dBm)	C.L (dB)	Ant Gain (dBd)	ERP (dBm)	Limits (dB)	(dBc)
Test Data for Low Channel								
1 648.40	40.39	H	-65.85	2.51	7.02	-70.36	40.99	98.35
2 472.60	40.84	H	-61.54	3.12	8.60	-67.02	40.99	95.01
3 296.80	40.23	H	-60.35	3.66	10.22	-66.91	40.99	94.90
Test Data for Middle Channel								
1 673.20	41.04	H	-65.23	2.53	7.14	-69.83	40.99	97.82
2 509.80	39.98	H	-62.37	3.13	8.62	-67.86	40.99	95.85
3 346.40	40.47	H	-60.17	3.69	10.35	-66.83	40.99	94.82
Test Data for High Channel								
1 697.60	40.55	H	-60.15	3.73	6.06	-62.49	40.99	90.48
2 546.40	40.16	H	-66.38	2.72	11.15	-74.81	40.99	102.80
3 395.20	40.89	H	-65.65	2.72	15.06	-77.99	40.99	105.98

Remark: Measured Output Power : 27.99 dBm Limit : $43+10\log(W) = 40.99$ dBc

“C.L” : Cable Loss, “H”: Horizontal, “V”: Vertical



Tested by: Min-Gu Ji / Assistant Manager

10.4.2 Test data for GSM1900

- . Test Date : December 03, 2017
- . Resolution bandwidth : 1 MHz for Peak and Average Mode for the emissions in restricted band,
100 kHz for Peak Mode for the emissions outside restricted band
- . Video bandwidth : 3 MHz for Peak Mode and Average Mode
300 kHz for Peak Mode for the emissions outside restricted band
- . Detector : RMS
- . Measurement distance : 3 m
- . Result : PASSED

Frequency (GHz)	S/A Reading (dBμV)	Ant. Pol. (H/V)	S/G Reading (dBm)	C.L (dB)	Ant Gain (dBd)	ERP (dBm)	Limits (dB)	(dBc)
Test Data for Low Channel								
3 700.40	41.20	H	-58.12	3.93	12.98	-49.07	36.52	72.60
5 550.60	40.30	H	-53.96	4.84	13.60	-45.20	36.52	68.73
7 400.80	40.46	H	-44.86	5.76	12.08	-38.54	36.52	62.07
Test Data for Middle Channel								
3 760.00	40.33	H	-58.46	3.97	13.01	-49.42	36.52	72.95
5 640.00	40.45	H	-53.39	4.89	13.53	-44.75	36.52	68.28
7 520.00	41.23	H	-43.96	5.80	11.98	-37.79	36.52	61.32
Test Data for High Channel								
3 819.60	40.48	H	-58.65	6.30	13.04	-51.91	36.52	75.44
5 729.40	40.66	H	-65.91	3.28	13.49	-55.70	36.52	79.23
7 639.20	40.89	H	-68.45	3.11	11.87	-59.68	36.52	83.21

Remark: Measured Output Power : 23.53 dBm Limit : 43+10log(W) = 36.52 dBc

“C.L” : Cable Loss, “H”: Horizontal, “V”: Vertical



Tested by: Min-Gu Ji / Assistant Manager

11. PEAK-TO-AVERAGE RATIO

11.1 Operating environment

Temperature	:	23 °C
Relative humidity	:	44 % R.H.

11.2 Test set-up

Peak to Average Power Ratio is tested in accordance with KDB971168 D01 Power Meas License Digital Systems v03, October 27, 2017, Section 5.7.

- Section 5.7.1 CCDF Procedure for PAPR

- a) Set resolution/measurement bandwidth \geq signal' s occupied bandwidth;
- b) Set the number of counts to a value that stabilizes the measured CCDF curve;
- c) Set the measurement interval as follows:
 - 1) for continuous transmissions, set to 1 ms,
 - 2) for burst transmissions, employ an external trigger that is synchronized with the EUT burst timing sequence, or use the internal burst trigger with a trigger level that allows the burst to stabilize and set the measurement interval to a time that is less than or equal to the burst duration.
- d) Record the maximum PAPR level associated with a probability of 0.1%.

- Section 5.7.2 Alternate Procedure for PAPR

Use one of the procedures presented in 5.1 to measure the total peak power and record as PPk. Use one of the applicable procedures presented 5.2 to measure the total average power and record as PAvg.

Determine the P.A.R. from: $P.A.R(dB) = PPk (dBm) - PAvg (dBm)$ (PAvg = Average Power + Duty cycle Factor)

5.1.1 Peak power measurements with a spectrum/signal analyzer or EMI receiver

The following procedure can be used to determine the total peak output power.

- a) Set the RBW \geq OBW.
- b) Set VBW $\geq 3 \times$ RBW.
- c) Set span $\geq 2 \times$ RBW
- d) Sweep time = auto couple.
- e) Detector = peak.
- f) Ensure that the number of measurement points \geq span/RBW.
- g) Trace mode = max hold.
- h) Allow trace to fully stabilize.
- i) Use the peak marker function to determine the peak amplitude level.

5.2.2 Procedures for use with a spectrum/signal analyzer when EUT cannot be configured to transmit continuously and sweep triggering/signal gating cannot be properly implemented

If the EUT cannot be configured to transmit continuously (burst duty cycle < 98%), then one of the following procedures can be used. The selection of the applicable procedure will depend on the characteristics of the measured burst duty cycle. Measure the burst duty cycle with a spectrum/signal analyzer or EMC receiver can be used in zero-span mode if the response time and spacing between bins on the sweep are sufficient to permit accurate measurement of the burst on/off time of the transmitted signal.

5.2.2.2 Constant burst duty cycle

If the measured burst duty cycle is constant (i.e., duty cycle variations are less than ± 2 percent), then:

- k) Set span to at least 1.5 times the OBW.
- l) Set RBW = 1-5% of the OBW, not to exceed 1 MHz.
- m) Set VBW ≥ 3 x RBW.
- n) Number of points in sweep ≥ 2 × span / RBW. (This gives bin-to-bin spacing ≤ RBW/2, so that narrowband signals are not lost between frequency bins.)
- o) Sweep time = auto.
- p) Detector = RMS (power averaging).
- q) Set sweep trigger to “free run”.
- r) Trace average at least 100 traces in power averaging (i.e., RMS) mode.
- s) Compute power by integrating the spectrum across the OBW of the signal using the instrument’s band power measurement function with band limits set equal to the OBW band edges. If the instrument does not have a band power function, sum the spectrum levels (in power units) at intervals equal to the RBW extending across the entire OBW of the spectrum.
- t) Add 10 log (1/x), where x is the duty cycle, to the measured power in order to compute the average power during the actual transmission times (because the measurement represents an average over both the on and off times of the transmission).

For example, add 10 log (1/0.25) = 6 dB if the duty cycle is a constant 25%.

11.3 Test equipment used

Model Number	Manufacturer	Description	Serial Number	Last Cal.
■ - FSV30	Rohde & Schwarz	Signal Analyzer	101199	Apr. 05, 2017 (1Y)
■ - E5515C	Agilent	WIRELESS COMMUNICATIONS TEST SET	MY48365015	Jun. 08, 2017 (1Y)
■ - E4419B	Agilent	Power Meter	MY45100286	Sep. 12, 2017(1Y)
■ - 8481H	Agilent	Power Sesor	3318A17600	Sep. 14, 2017(1Y)

All test equipment used is calibrated on a regular basis.

11.4 Test data

-. Test Date : November 20, 2017

-. Test Result : Pass

Band	Channel	Measured Ppk (dBm)	Measured Pav (dBm)	Duty Cycle (dB)	P.A.R (dB)	Limit (dB)	Result
GSM1900	512	29.46	18.03	9.25	2.18	13.00	PASS
GSM1900 EDGE	810	29.15	17.95	9.25	1.95	13.00	PASS

Remark: $P.A.R_{(dB)} = P_{Pk (dBm)} - P_{Avg (dBm)}$ (P_{Avg} = Average Power + Duty cycle Factor)

$$\text{Duty cycle Factor} = 10 \log (1/x), x = T_{xOn} / T_{xTotal}$$



Tested by: Min-Gu Ji / Assistant Manager

12. OCCUPIED BANDWIDTH

12.1 Operating environment

Temperature : 23 °C
 Relative humidity : 44 % R.H.

12.2 Test set-up

The emission bandwidth (×dB) is defined as the frequency range between two points, one above and one below the carrier frequency, at which the spectral density of the emission is attenuated × dB below the maximum in-band spectral density of the modulated signal. Spectral density (power per unit bandwidth) is to be measured with a detector of resolution bandwidth in the range of 1% to 5% of the anticipated emission bandwidth, and a video bandwidth at least 3× the resolution bandwidth. When the occupied bandwidth limit is not stated in the applicable RSS or reference measurement method, the transmitted signal bandwidth shall be reported as the 99% emission bandwidth, as calculated or measured.

- The transmitter shall be operated at its maximum carrier power measured under normal test conditions.
- The span of the analyzer shall be set to capture all products of the modulation process, including the emission skirts.
- The resolution bandwidth (RBW) shall be in the range of 1% to 5% of the occupied bandwidth (OBW) and video bandwidth (VBW) shall be approximately 3×RBW.

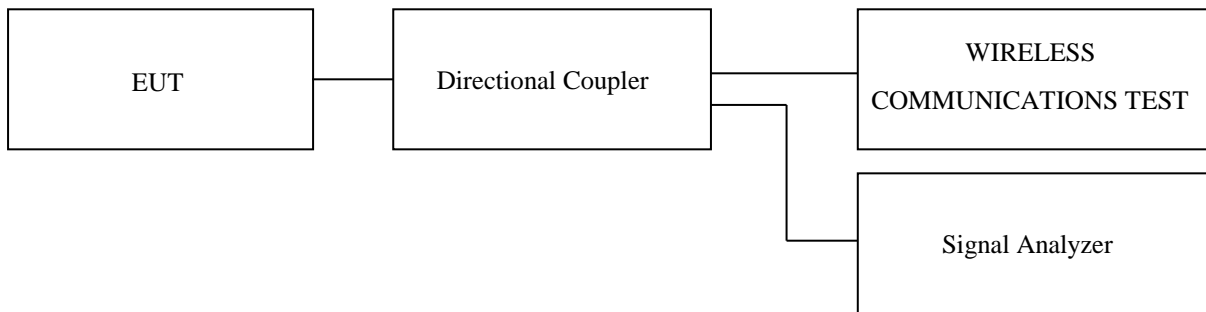

12.3 Test equipment used

Model Number	Manufacturer	Description	Serial Number	Last Cal.
■ - FSV30	Rohde & Schwarz	Signal Analyzer	101199	Apr. 05, 2017 (1Y)
■ - E5515C	Agilent	WIRELESS COMMUNICATIONS TEST SET	MY48365015	Jun. 08, 2017 (1Y)

All test equipment used is calibrated on a regular basis.

12.4 Test data

12.4.1 Test data for GSM850

-. Test Date : November 20, 2017

-. Test Result : Pass

Band	Channel	26 dB Bandwidth (kHz)	99 % Occupied Bandwidth (kHz)	Result
GSM850	Low	315.70	243.76	PASS
	Middle	315.70	243.76	PASS
	High	320.70	242.76	PASS
	EDGE	322.70	242.75	PASS



Tested by: Min-Gu Ji / Assistant Manager

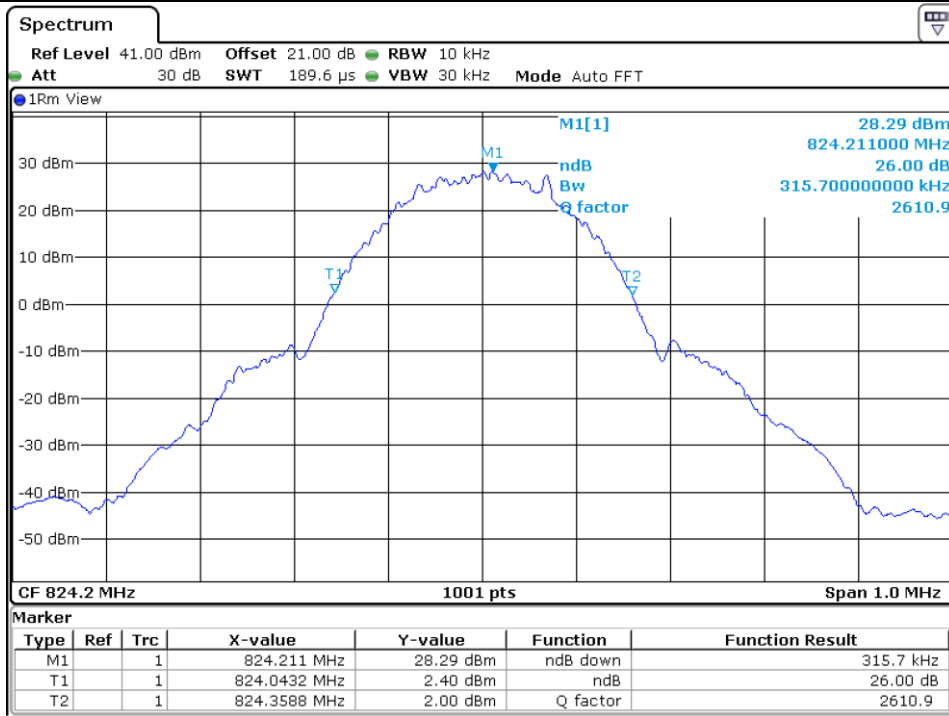

Low Channel (26 dB Bandwidth)

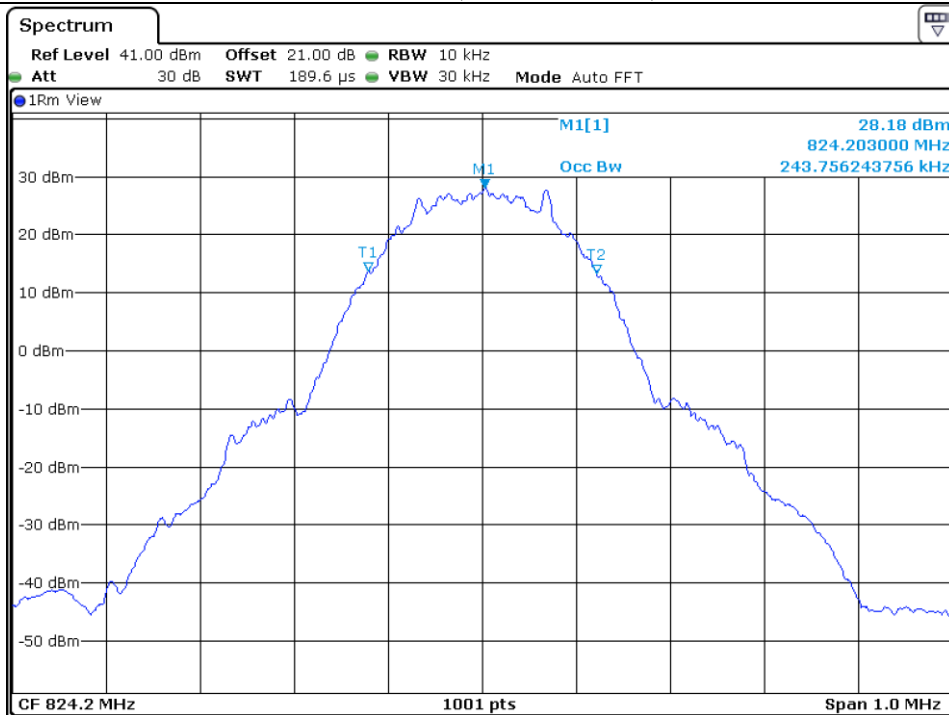

Low Channel (99 % Occupied Bandwidth)

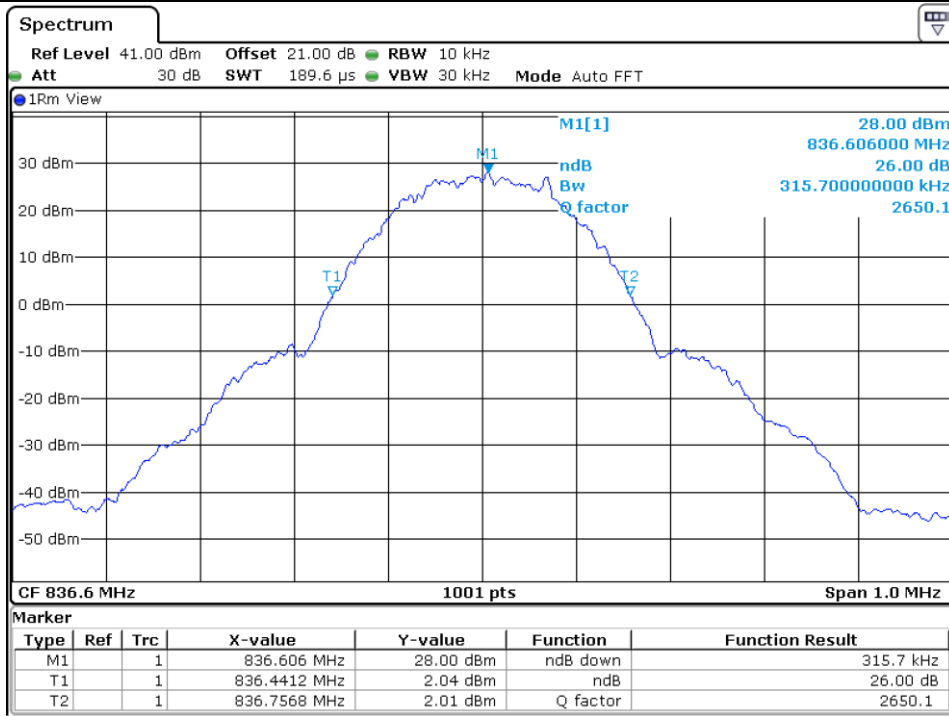

Middle Channel (26 dB Bandwidth)

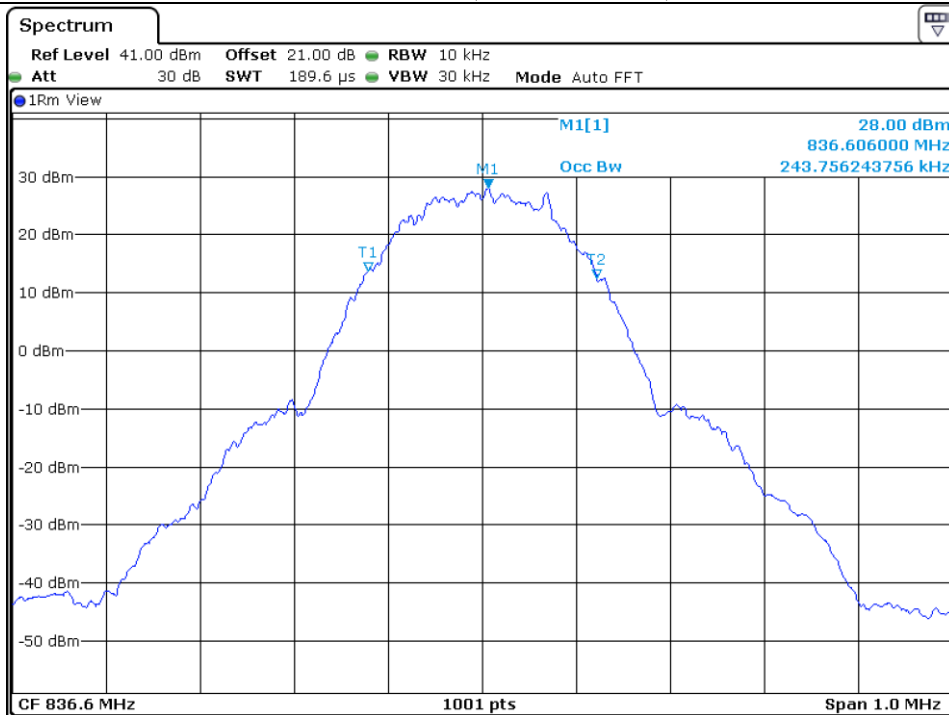

Middle Channel (99 % Occupied Bandwidth)

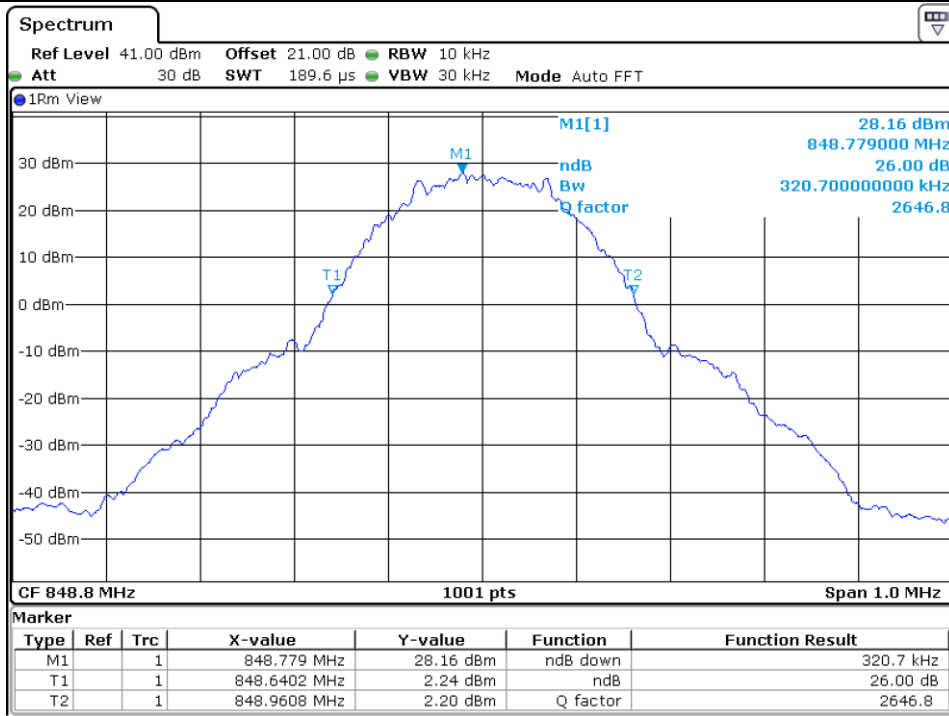

High Channel (26 dB Bandwidth)

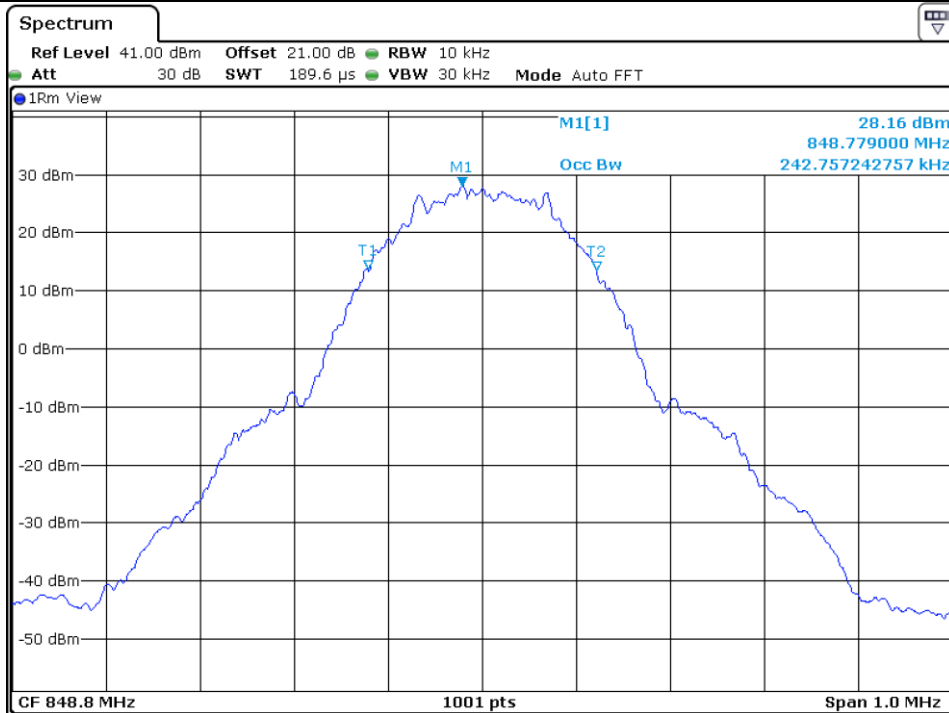

High Channel (99 % Occupied Bandwidth)

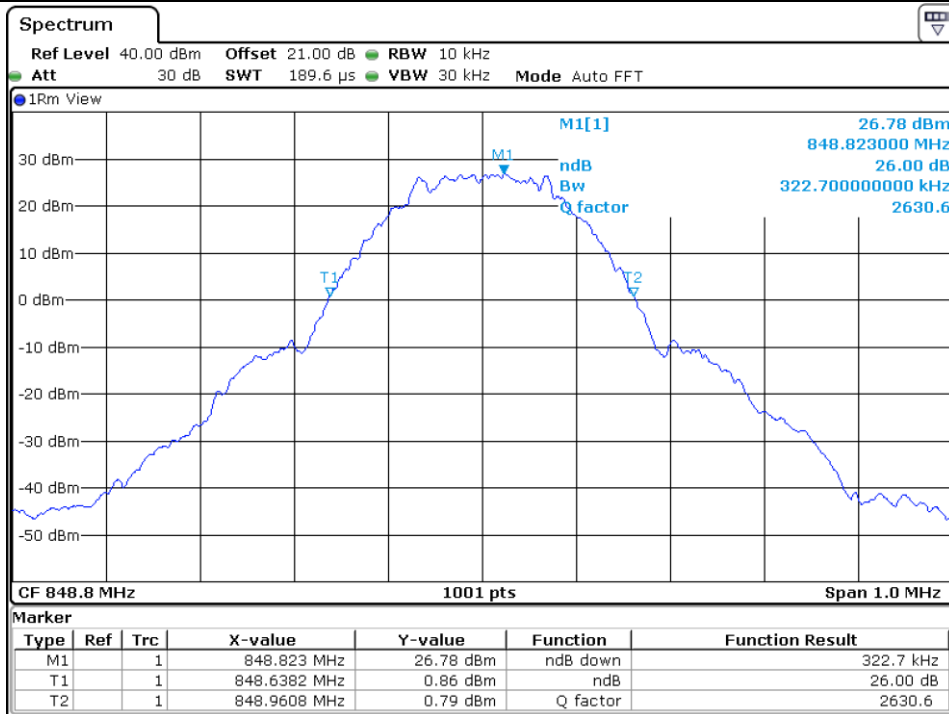

EDGE (26 dB Bandwidth)

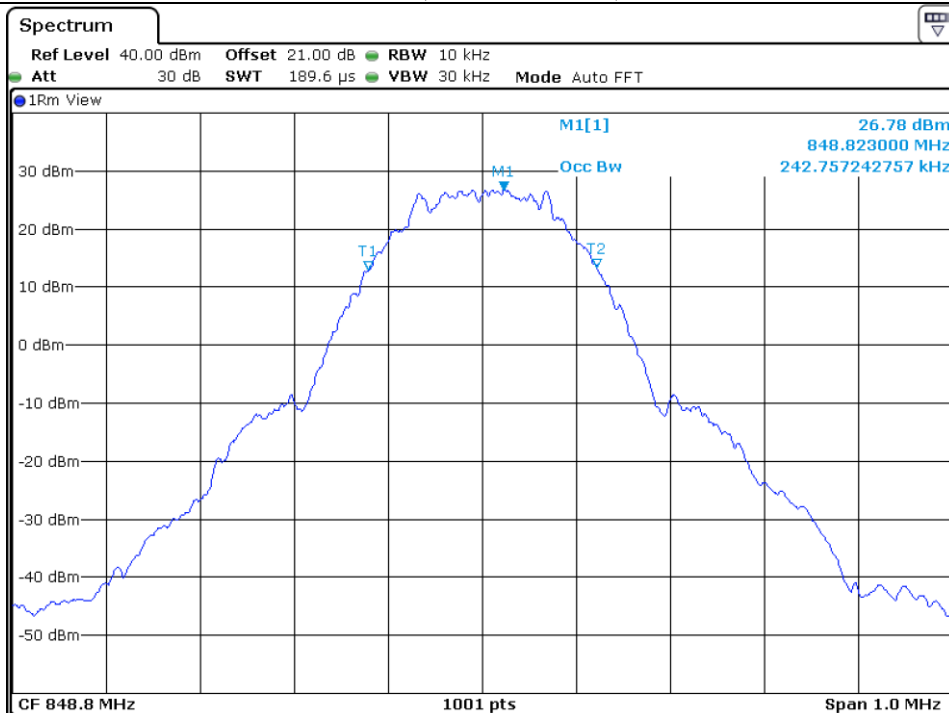

EDGE (99 % Occupied Bandwidth)

12.4.2 Test data for GSM1900

-. Test Date : November 20, 2017

-. Test Result : Pass

Band	Channel	26 dB Bandwidth (kHz)	99 % Occupied Bandwidth (kHz)	Result
GSM1900	Low	317.70	237.76	PASS
	Middle	312.70	236.76	PASS
	High	319.70	237.76	PASS
	EDGE	317.70	234.77	PASS



Tested by: Min-Gu Ji / Assistant Manager

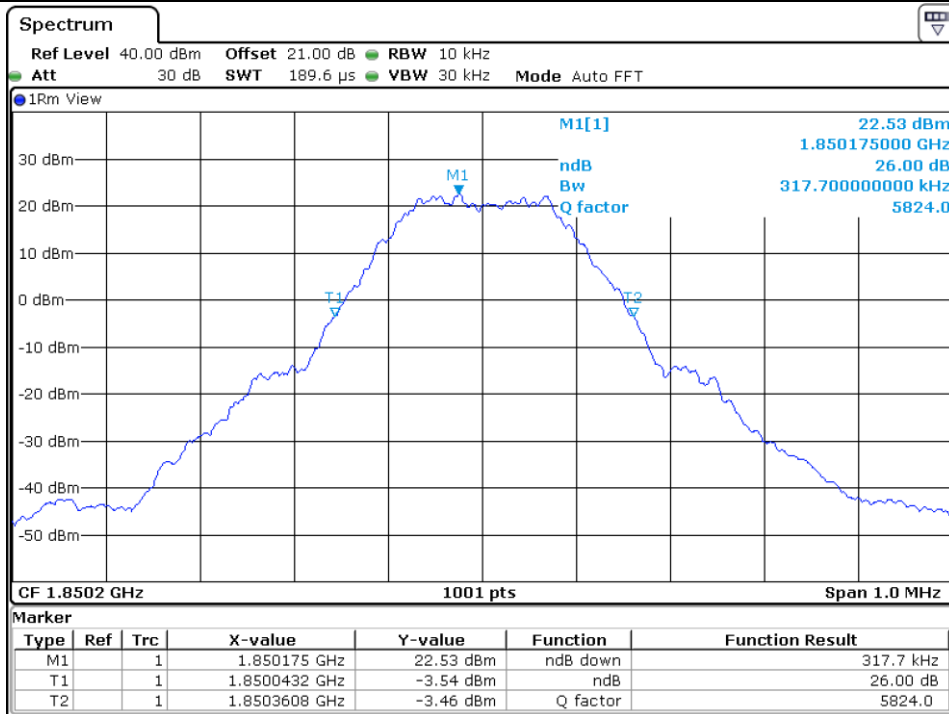

Low Channel (26 dB Bandwidth)

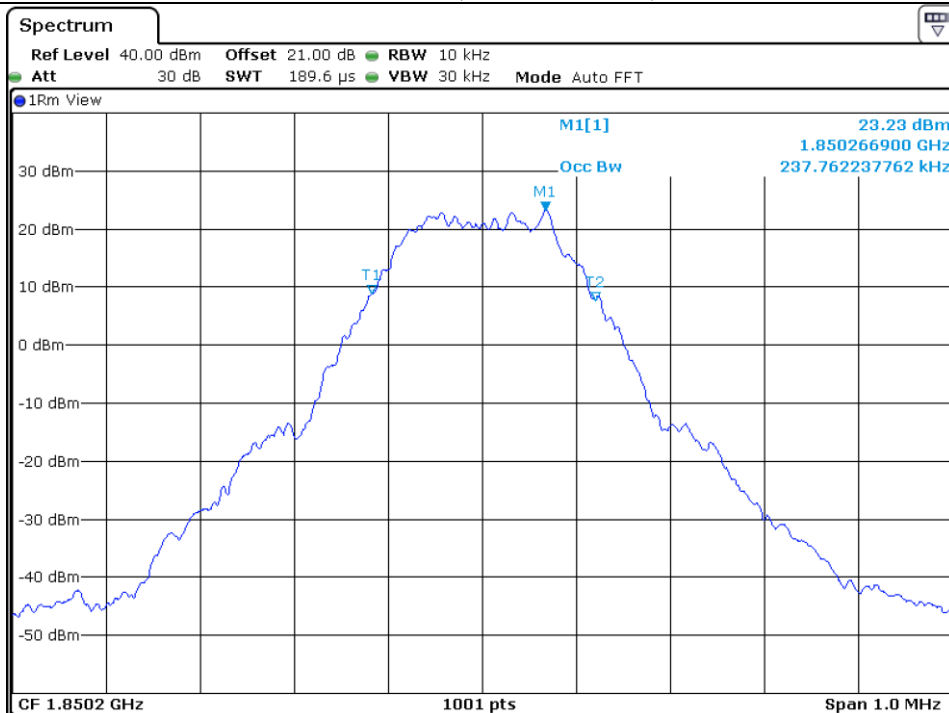

Low Channel (99 % Occupied Bandwidth)

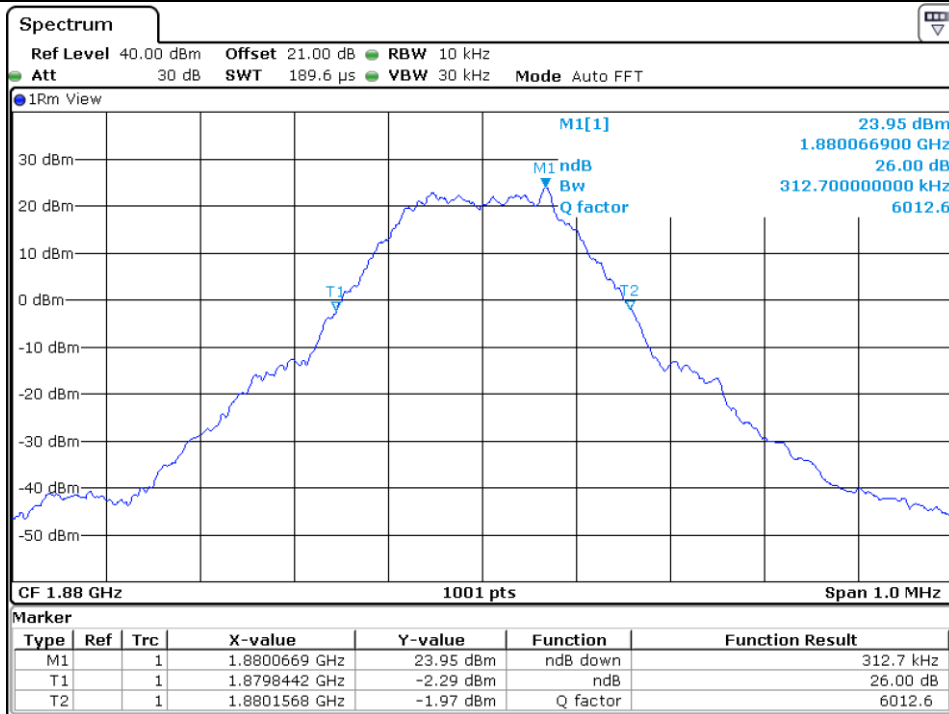

Middle Channel (26 dB Bandwidth)

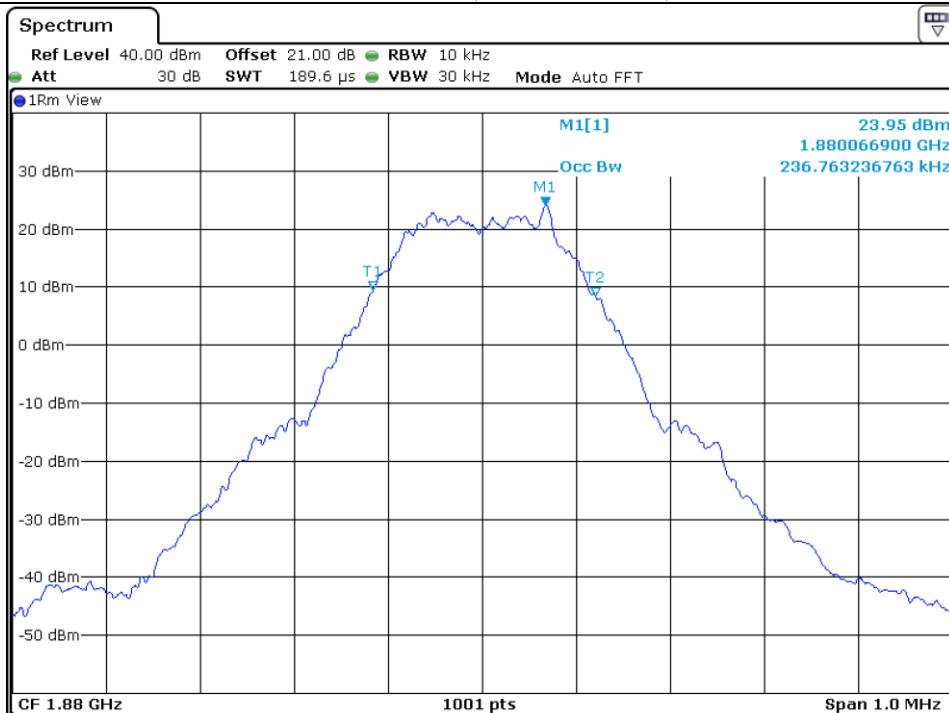

Middle Channel (99 % Occupied Bandwidth)

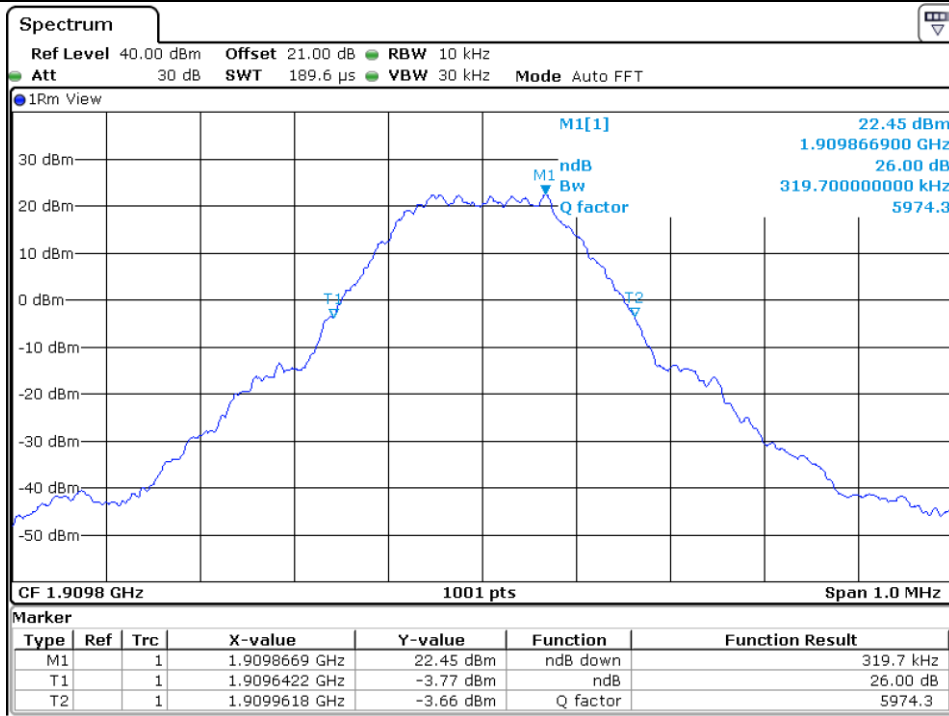

High Channel (26 dB Bandwidth)

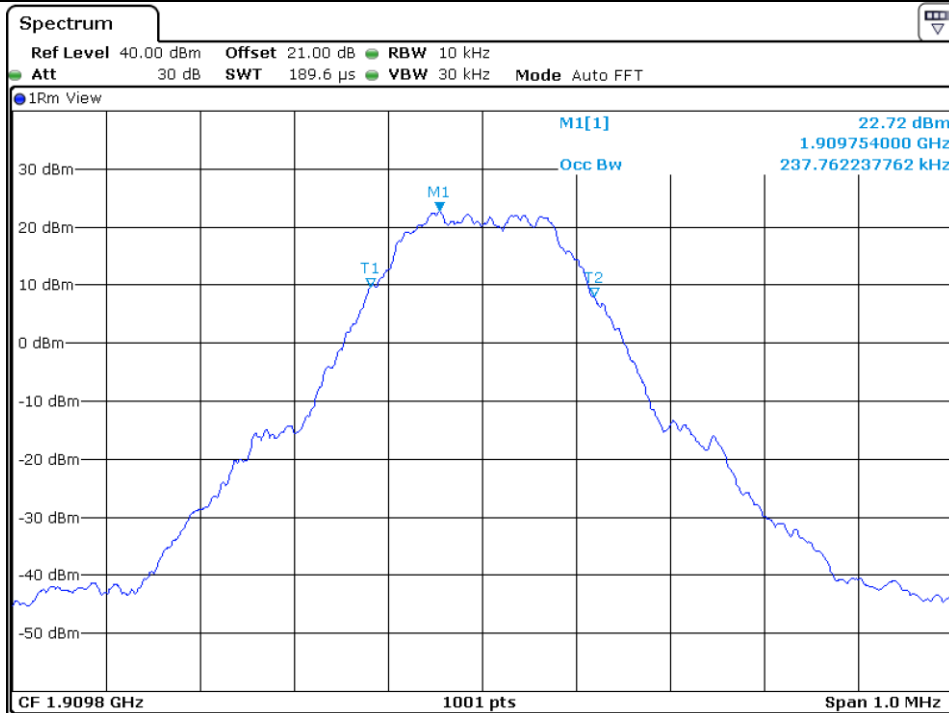

High Channel (99 % Occupied Bandwidth)

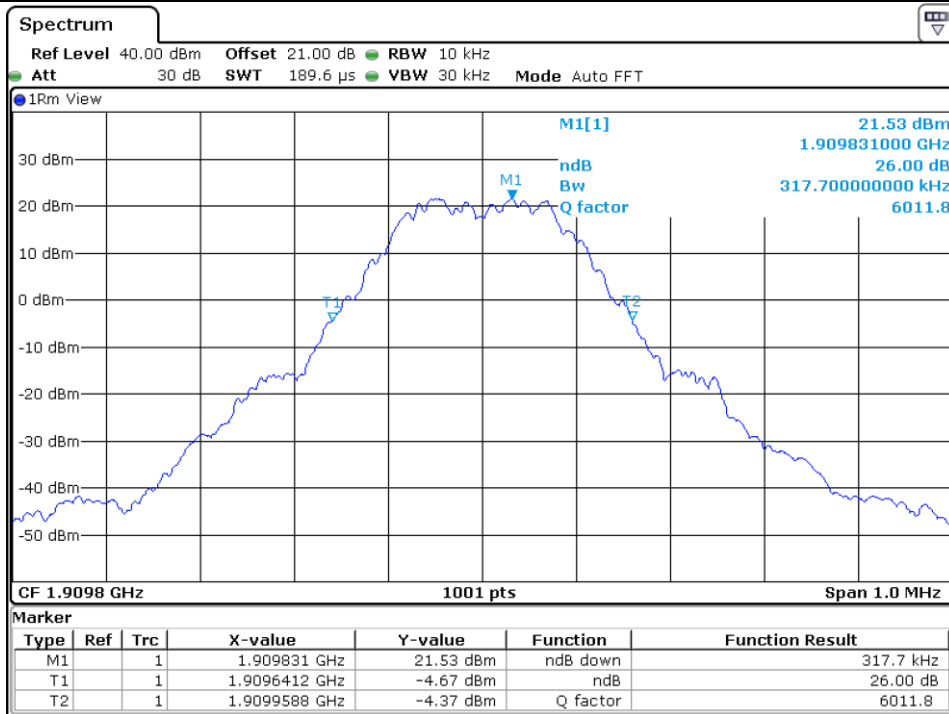

EDGE (26 dB Bandwidth)

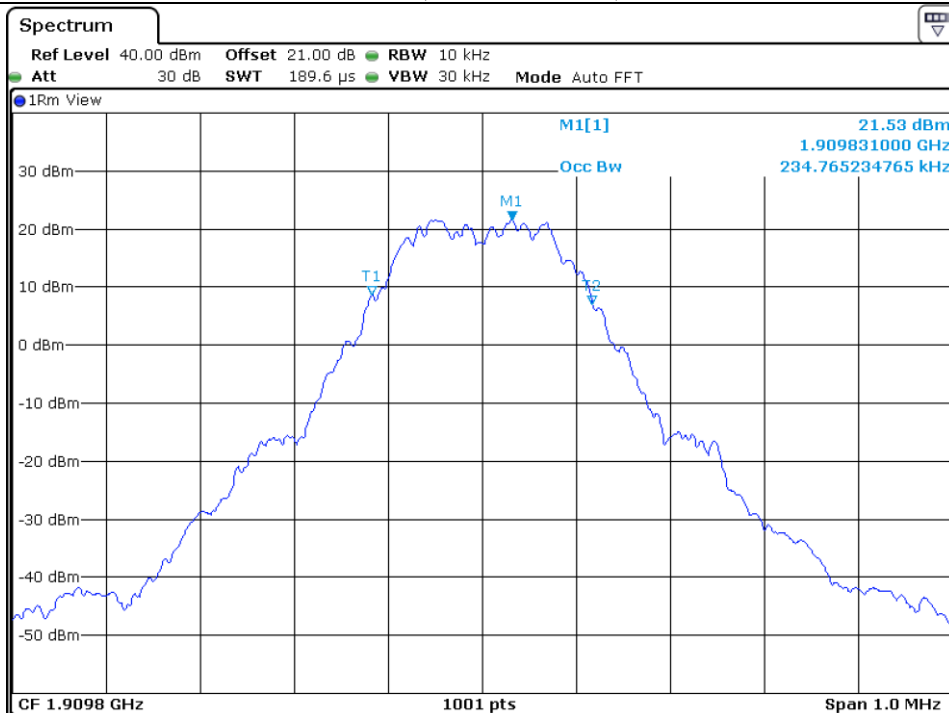

EDGE (99 % Occupied Bandwidth)

13. CONDUCTED SPURIOUS EMISSIONS

13.1 Operating environment

Temperature : 23 °C
 Relative humidity : 44 % R.H.

13.2 Test set-up

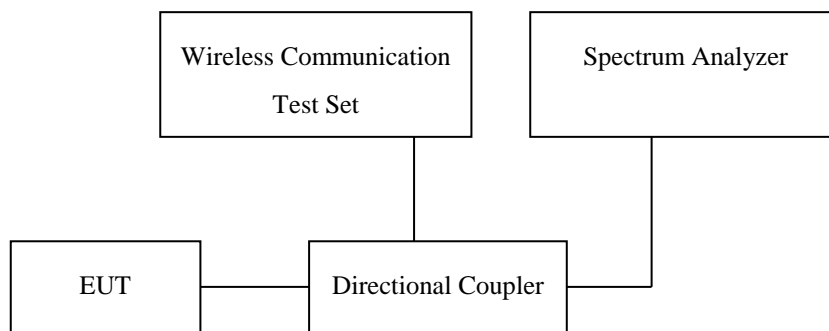

(Configuration of conducted Emission measurement)

Conducted Spurious Emissions is tested in accordance with KDB971168 D01 Power Meas License Digital Systems v03, October 27, 2017, Section 6 and RSS-Gen, November 2014, Issue4, Section 6.6

The EUT makes a call to the communication simulator. The power was measured with R&S Spectrum Analyzer. All measurements were done at 3 channels(low, middle and high operational range.)

The Conducted Spurious Emissions used the power splitter via EUT RF power connector between simulation base station and spectrum analyzer.

The communication simulator station system controlled a EUT to export maximum output power under transmission mode and specific channel frequency.

13.3 Test equipment used

Model Number	Manufacturer	Description	Serial Number	Last Cal.
■ - FSV30	Rohde & Schwarz	Signal Analyzer	101199	Apr. 05, 2017 (1Y)
■ - E5515C	Agilent	WIRELESS COMMUNICATIONS TEST SET	MY48365015	Jun. 08, 2017 (1Y)

All test equipment used is calibrated on a regular basis.

13.4 Test data

13.4.1 Test data for GSM850

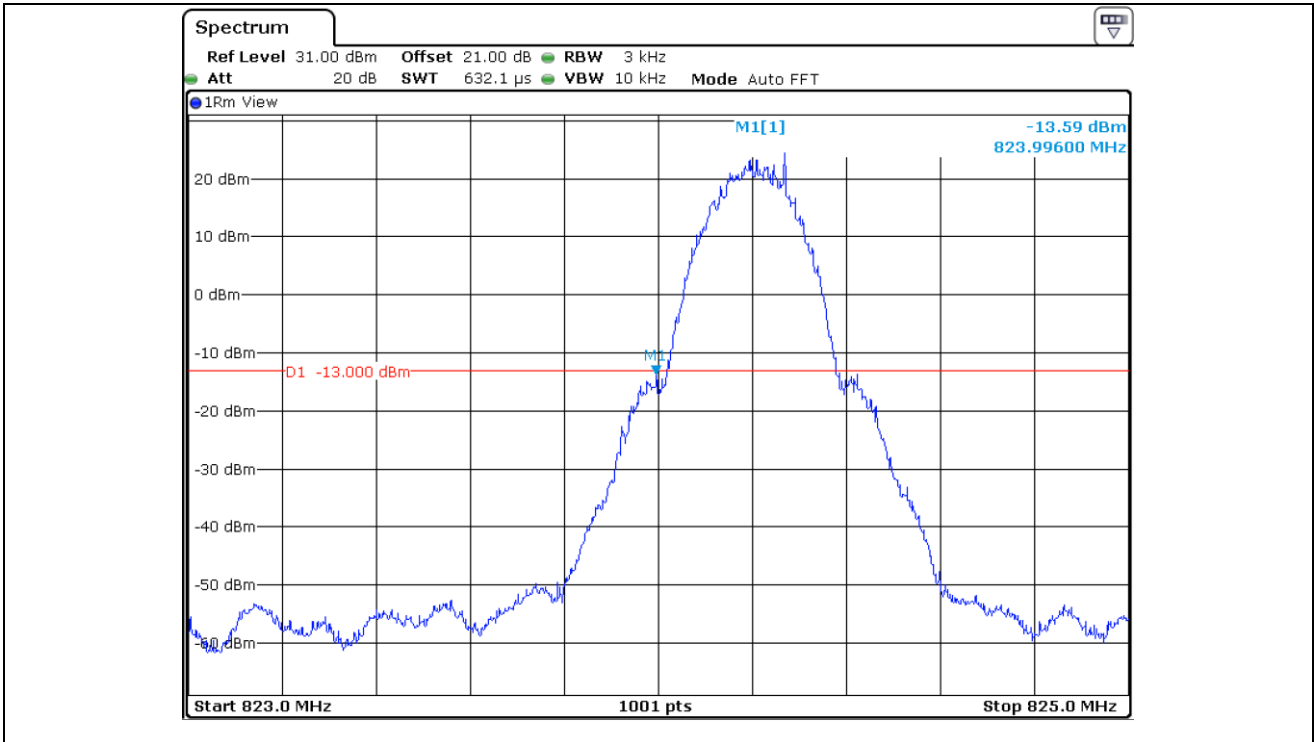

Low Channel

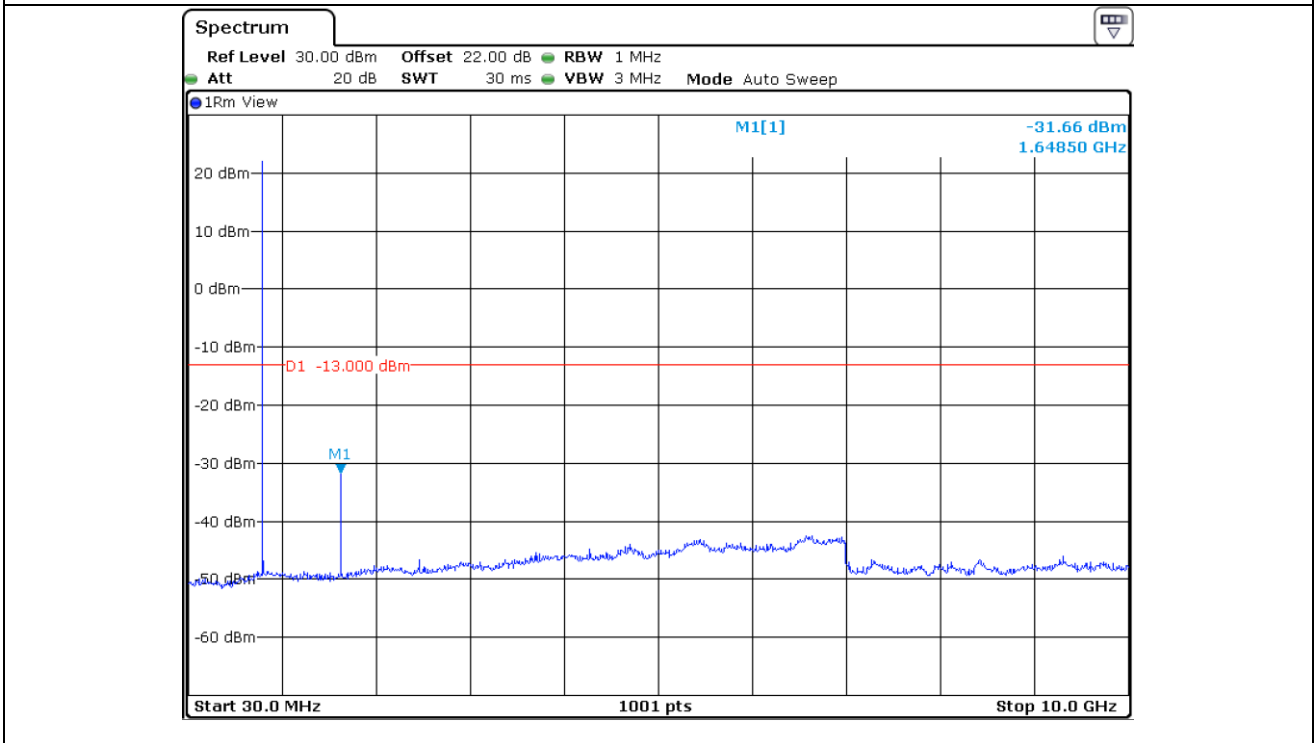

Low Channel

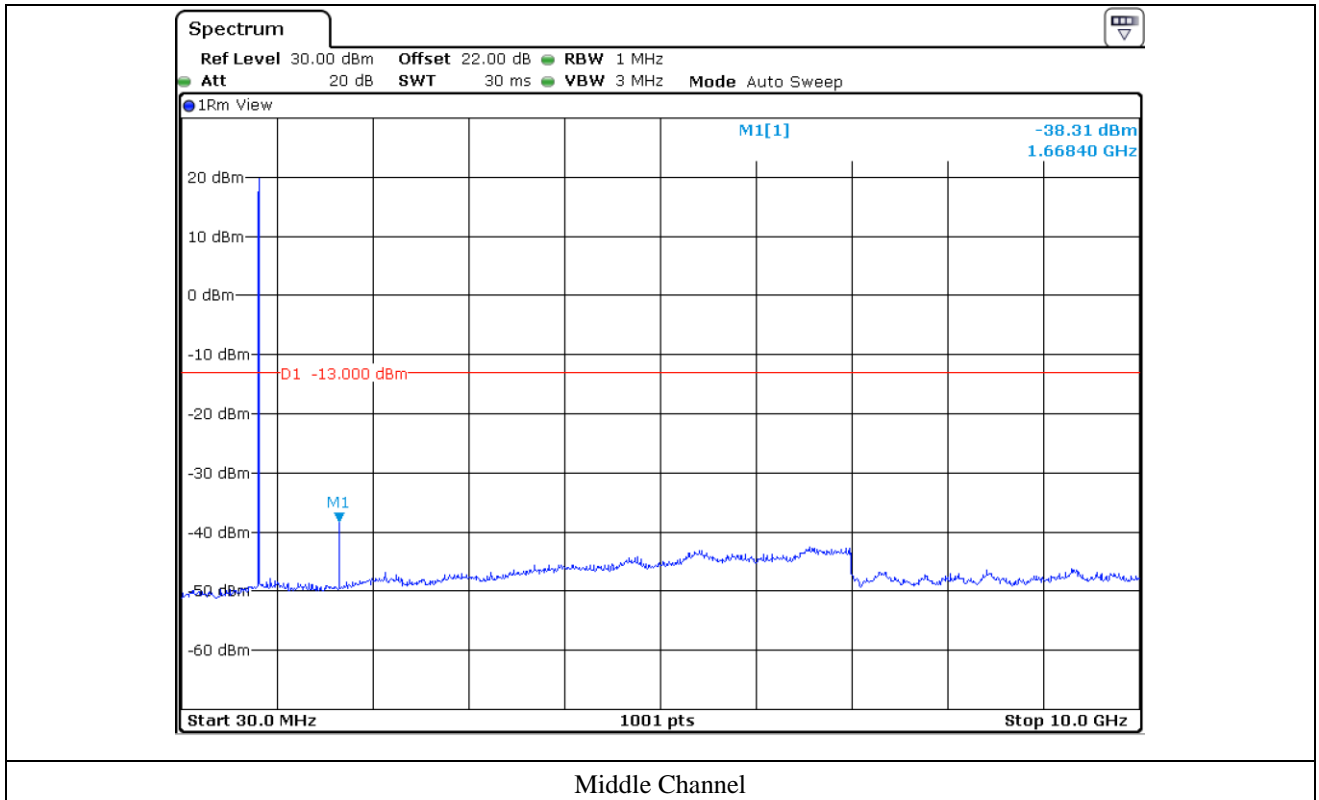

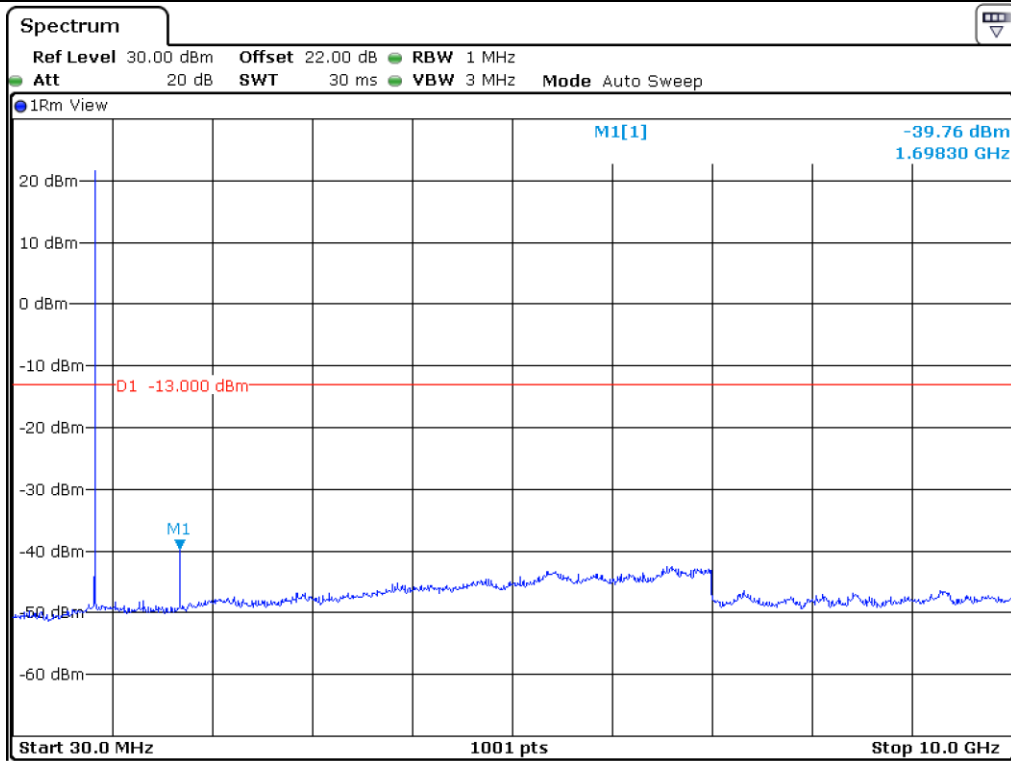

High Channel

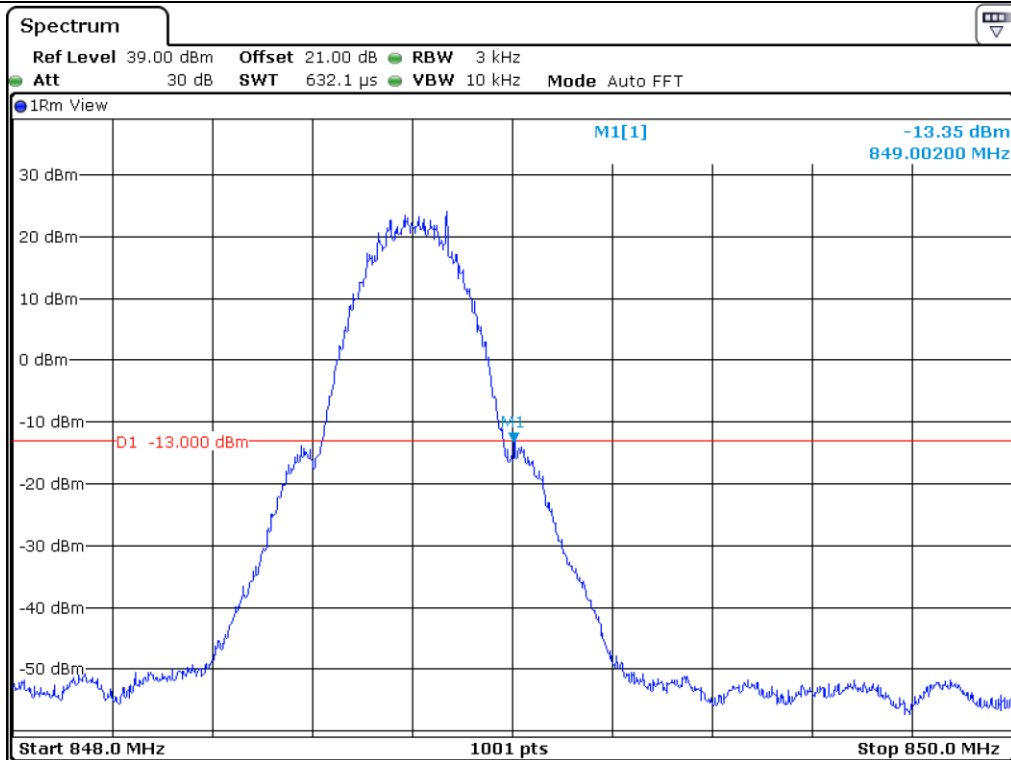

High Channel

13.4.2 Test data for GSM1900

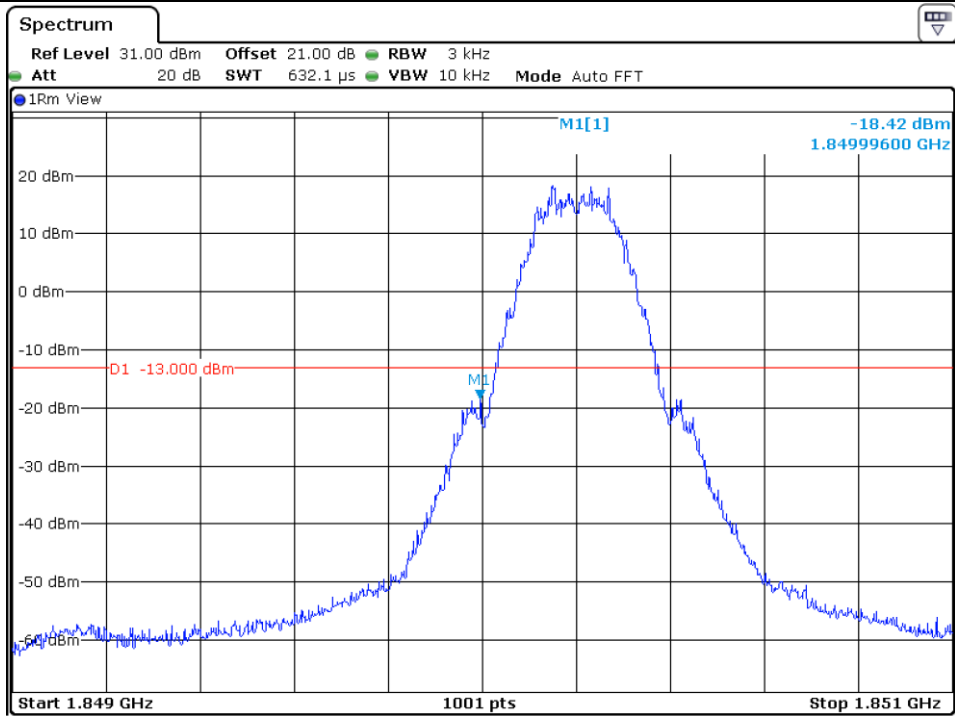

Low Channel

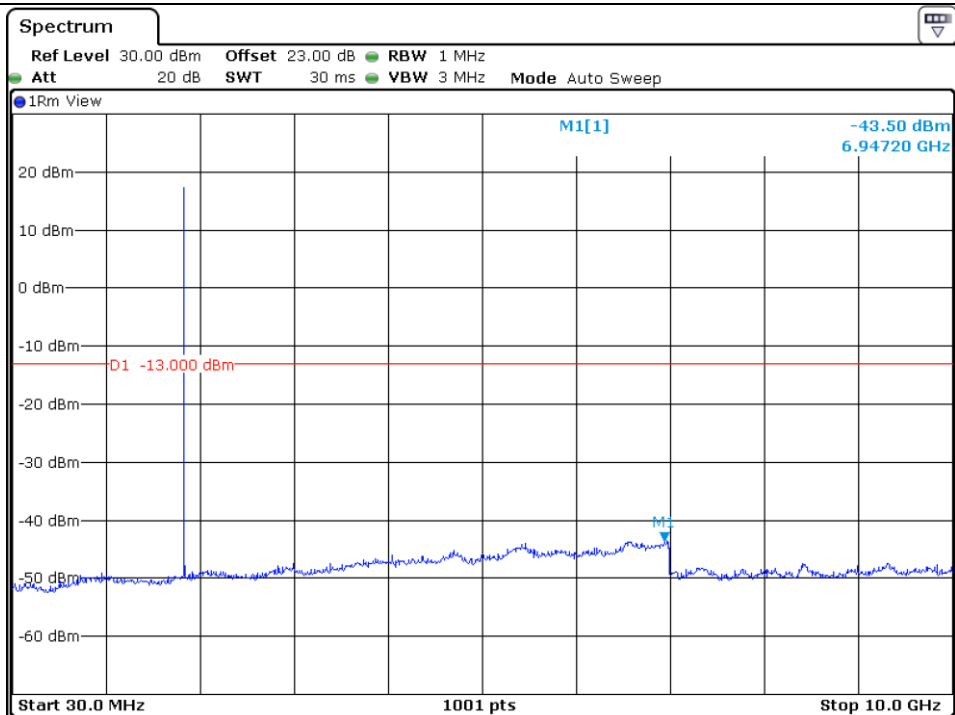

Low Channel

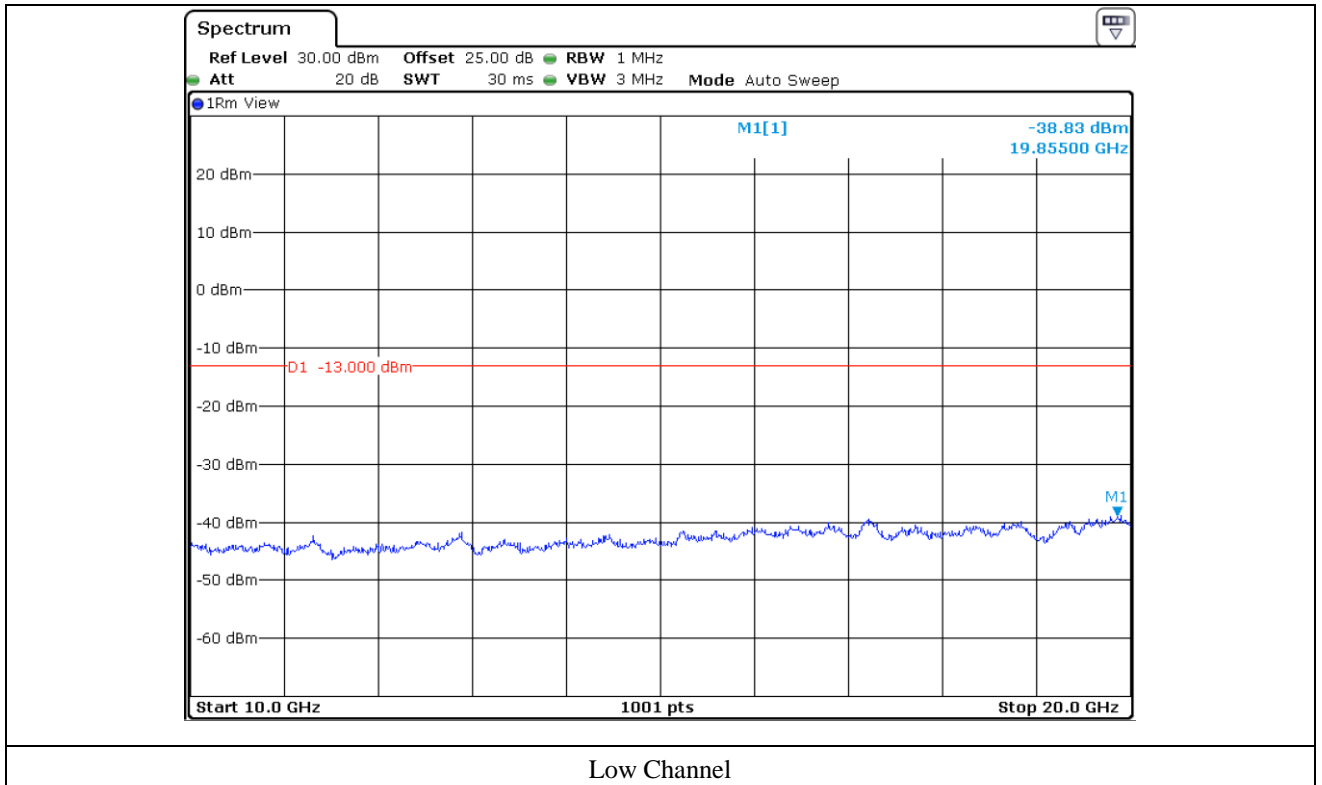

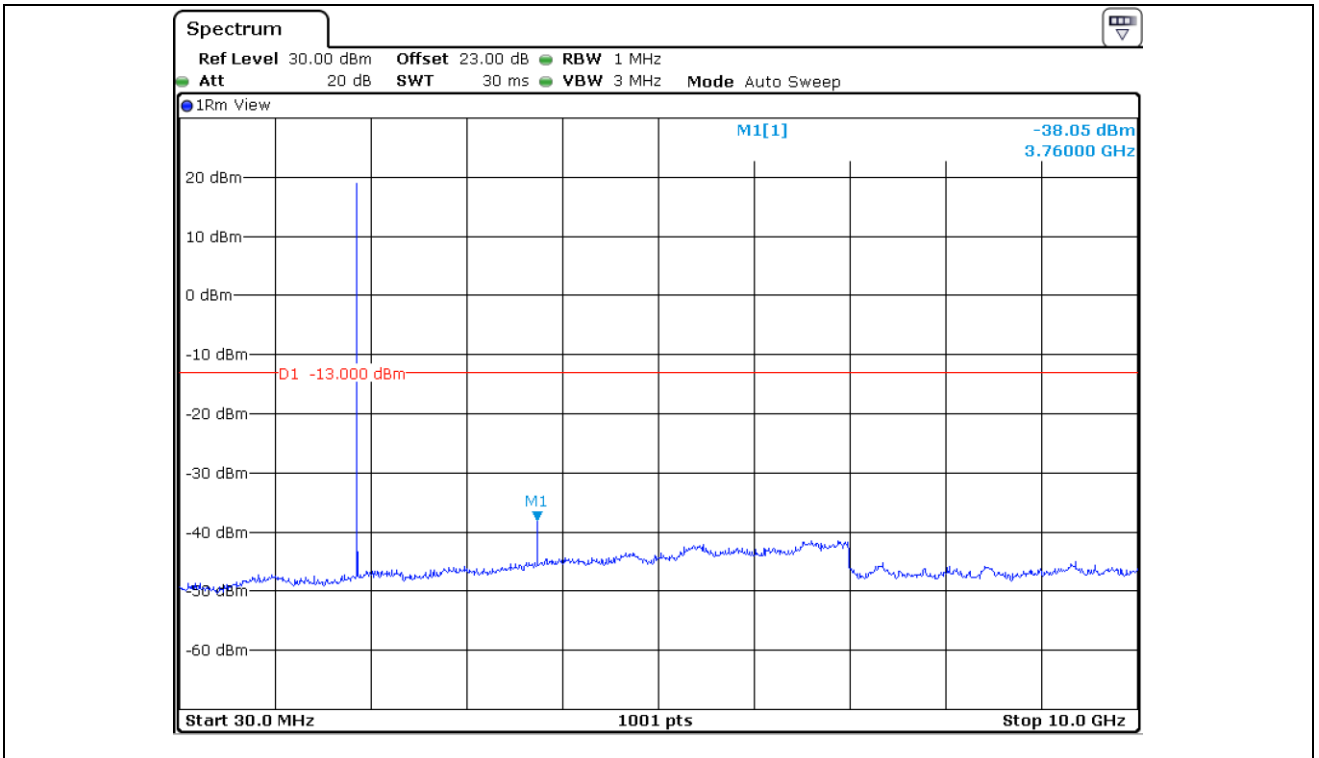

Middle Channel

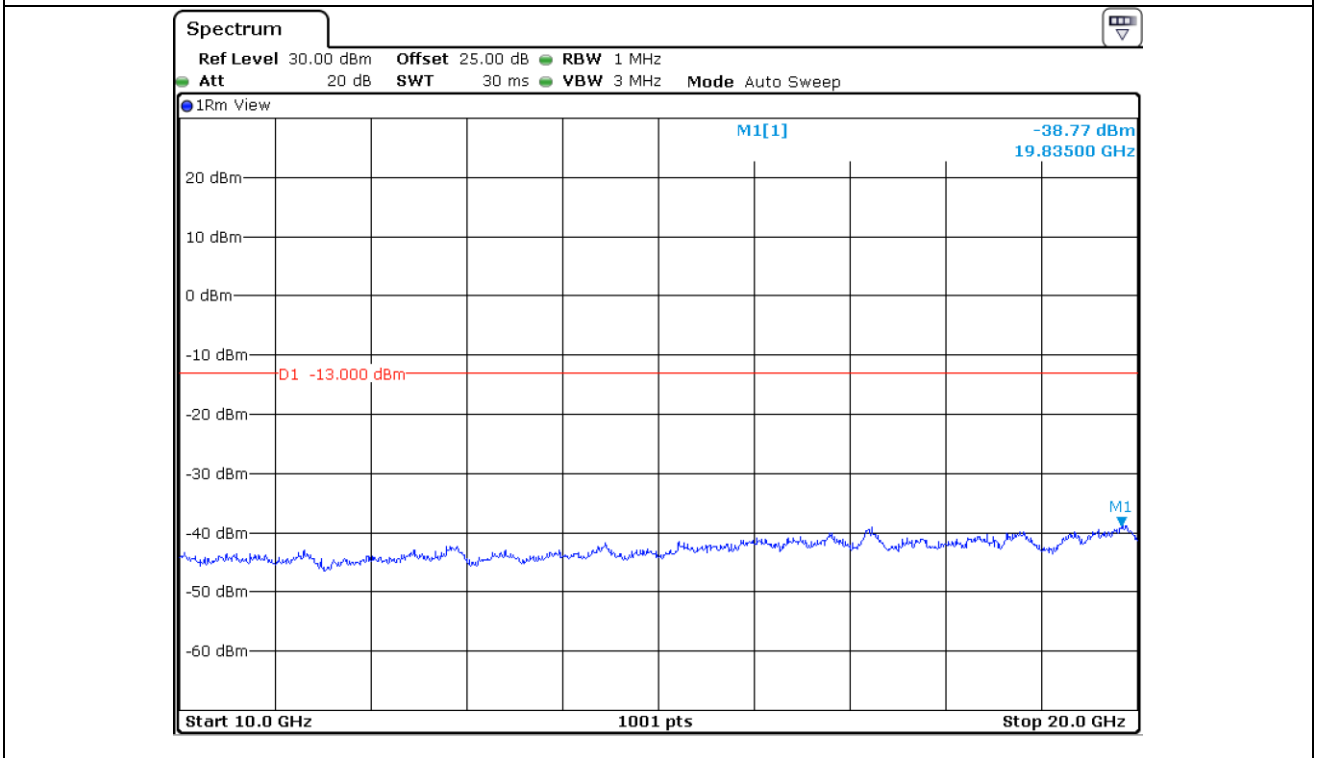

Middle Channel

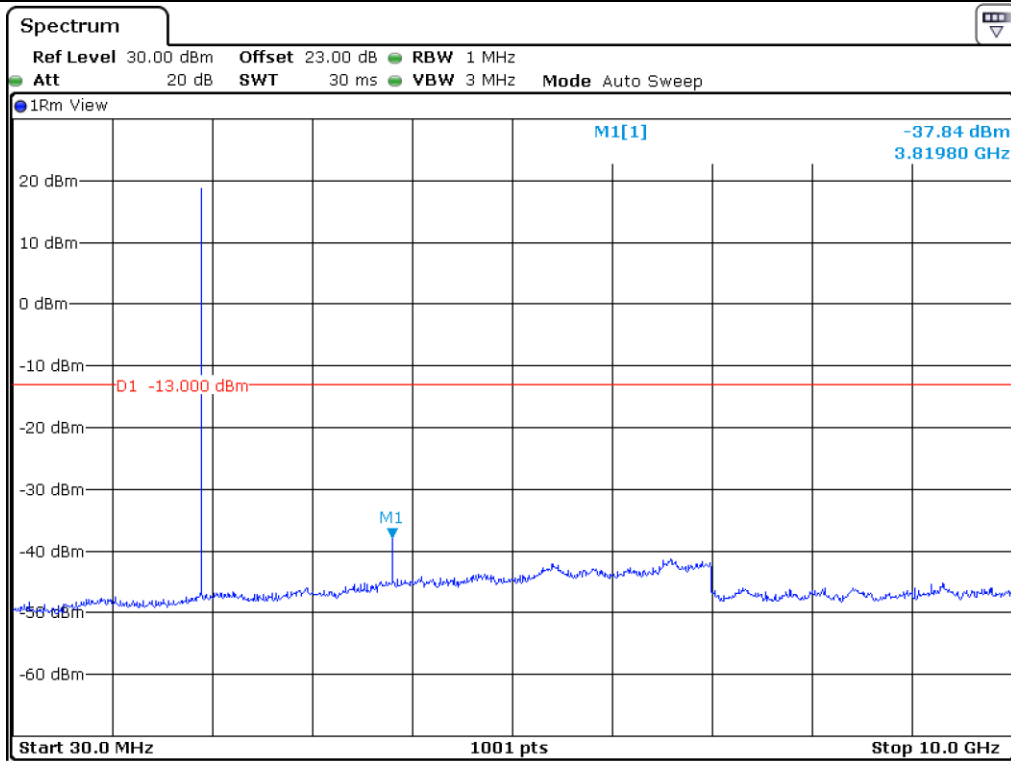

High Channel

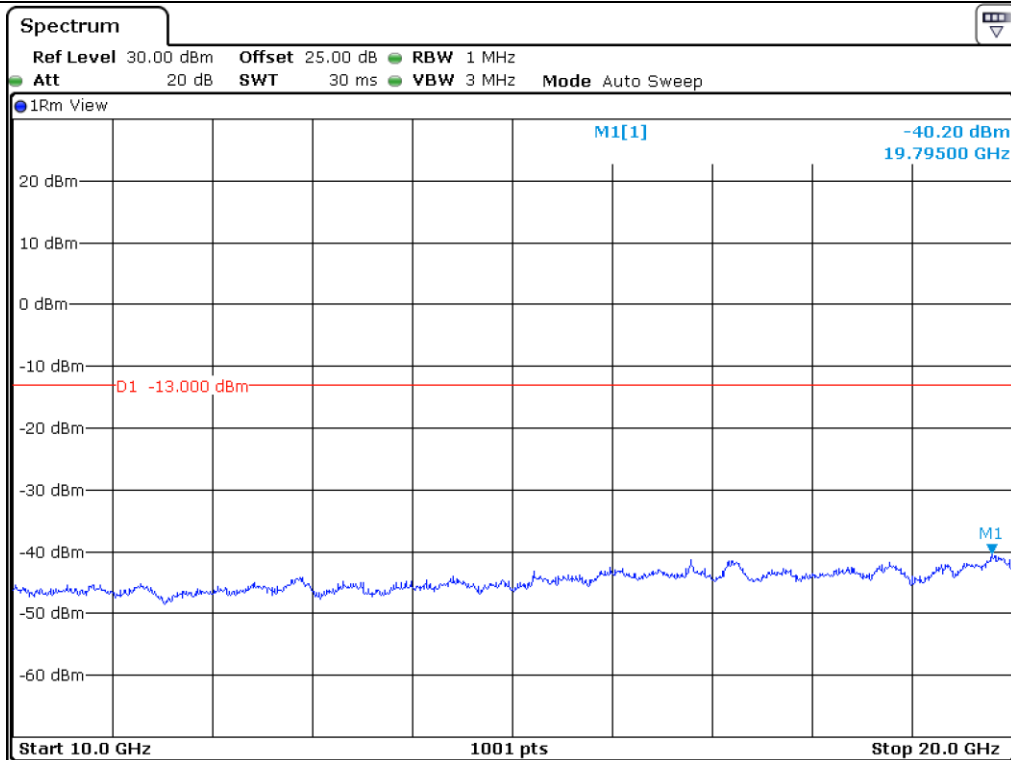

High Channel

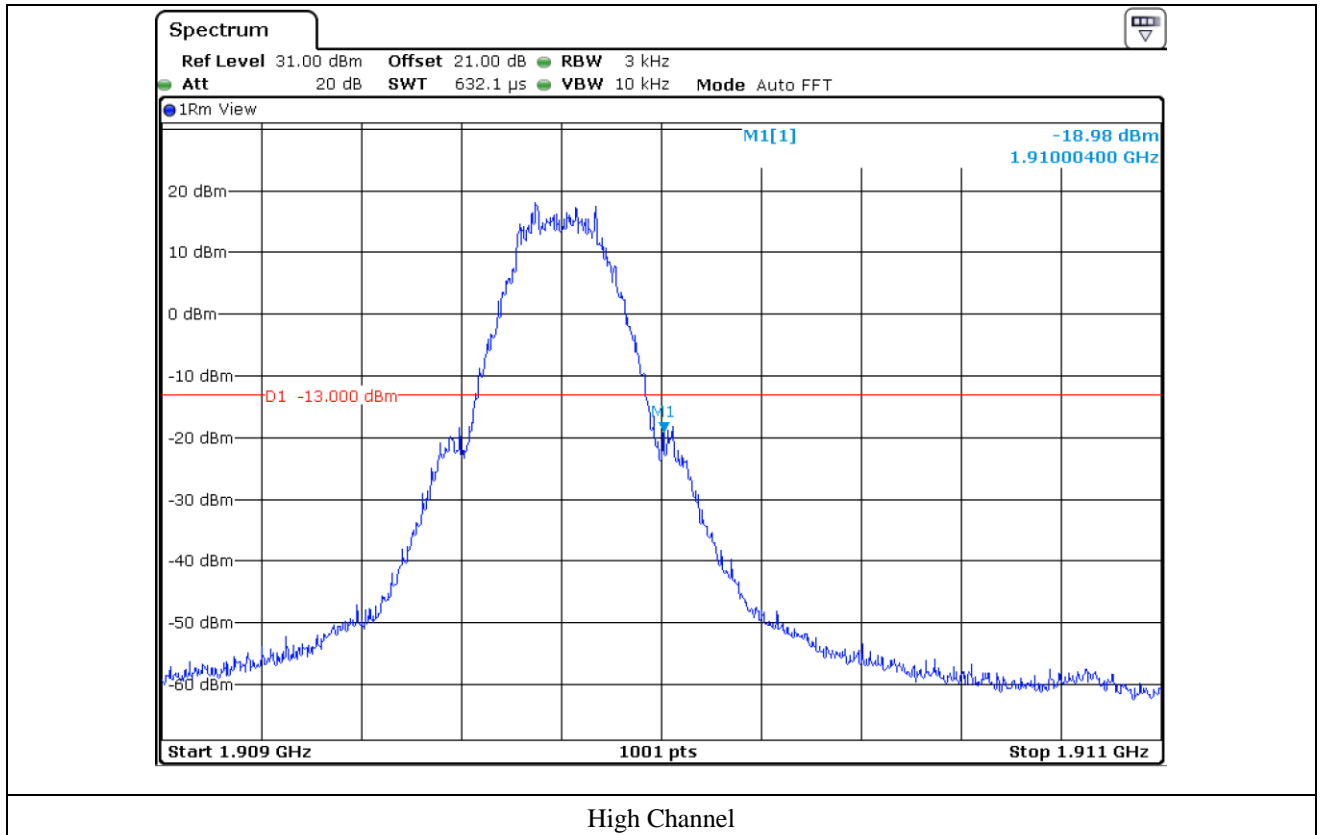

14. FREQUENCY STABILITY / VARIATION OF AMBIENT TEMPERATURE

14.1 Operating environment

Temperature : 23 °C
 Relative humidity : 44 % R.H.

14.2 Test set-up

Turn EUT off and set chamber temperature to -30 °C and then allow sufficient time (approximately 20 to 30 minutes after chamber reach the assigned temperature) for EUT to stabilize. Turn ON EUT and measure the EUT operating frequency and then turn off the EUT after the measurement. The temperature in the chamber was raised 10 °C step from -30 °C to +50 °C. Repeat above method for frequency measurements every 10 °C step and then record all measured frequencies on each temperature step.

14.3 Test equipment used

	Model Number	Manufacturer	Description	Serial Number	Last Cal.
■ -	FSV30	Rohde & Schwarz	Signal Analyzer	101199	Apr. 05, 2017 (1Y)
■ -	E5515C	Agilent	WIRELESS COMMUNICATIONS TEST SET	MY48365015	Jun. 08, 2017 (1Y)
■ -	PSL-2KP	ESPEC	Environmental Test Chamber	14009407	Feb. 02, 2017 (1Y)

All test equipment used is calibrated on a regular basis.

14.4 Test data

14.4.1 Test data for GSM850

Temperature(° C)	Power(VDC)	Center Freq.	Measured Freq.	PPM
-30	12 V	836 600 000	836 599 997	-0.003 6
-20			836 599 996	-0.004 8
-10			836 599 997	-0.003 6
0			836 599 997	-0.003 6
10			836 599 997	-0.003 6
20			836 600 000	0.000 0
30			836 599 995	-0.006 0
40			836 599 997	-0.003 6
50			836 599 997	-0.003 6

14.4.2 Test data for GSM1900

Temperature(° C)	Power(VDC)	Center Freq.	Measured Freq.	PPM
-30	12 V	1 880 000 000	1 879 999 992	-0.004 3
-20			1 879 999 996	-0.002 1
-10			1 879 999 994	-0.003 2
0			1 879 999 995	-0.002 7
10			1 879 999 997	-0.001 6
20			1 880 000 000	0.000 0
30			1 879 999 992	-0.004 3
40			1 879 999 994	-0.003 2
50			1 879 999 997	-0.001 6



Tested by: Min-Gu Ji / Assistant Manager

15. CONDUCTED EMISSION TEST

15.1 Operating environment

Temperature : 23 °C
 Relative humidity : 42 % R.H.

15.2 Test set-up

The EUT was placed on a wooden table, 0.8 m height above the floor. Power was fed to the EUT through a 50 Ω / 50 μH + 5 Ω Artificial Mains Network (AMN). The ground plane was electrically bonded to the reference ground system and all power lines were filtered from ambient.

15.3 Test equipment used

	Model Number	Manufacturer	Description	Serial Number	Last Cal. (Interval)
■ -	ESPI	Rohde & Schwarz	EMI Test Receiver	101278	Oct. 27, 2017 (1Y)
□ -	ESHS10	Rohde & Schwarz	EMI Test Receiver	834467/007	Apr. 03, 2017 (1Y)
□ -	NSLK8128	Schwarzbeck	AMN	8128-216	Apr. 05, 2017 (1Y)
□ -	NSLK8126	Schwarzbeck	AMN	8126-404	Apr. 03, 2017 (1Y)
■ -	NSLK8126	Schwarzbeck	AMN	8126-479	Oct. 24, 2017 (1Y)
■ -	NNBM 8124	SCHWARZ BECK	V-LISN	05066	Oct. 24, 2017 (1Y)
■ -	NNBM 8124	SCHWARZ BECK	V-LISN	05019	Oct. 25, 2017 (1Y)
□ -	3825/2	EMCO	AMN	9109-1869	Apr. 06, 2017 (1Y)

All test equipment used is calibrated on a regular basis.

15.4 Test data

15.4.1 Test data for GSM850

- Test Date : December 08, 2017
- Resolution bandwidth : 9 kHz
- Frequency range : 0.15 MHz ~ 30 MHz
- Tested Line : HOT LINE

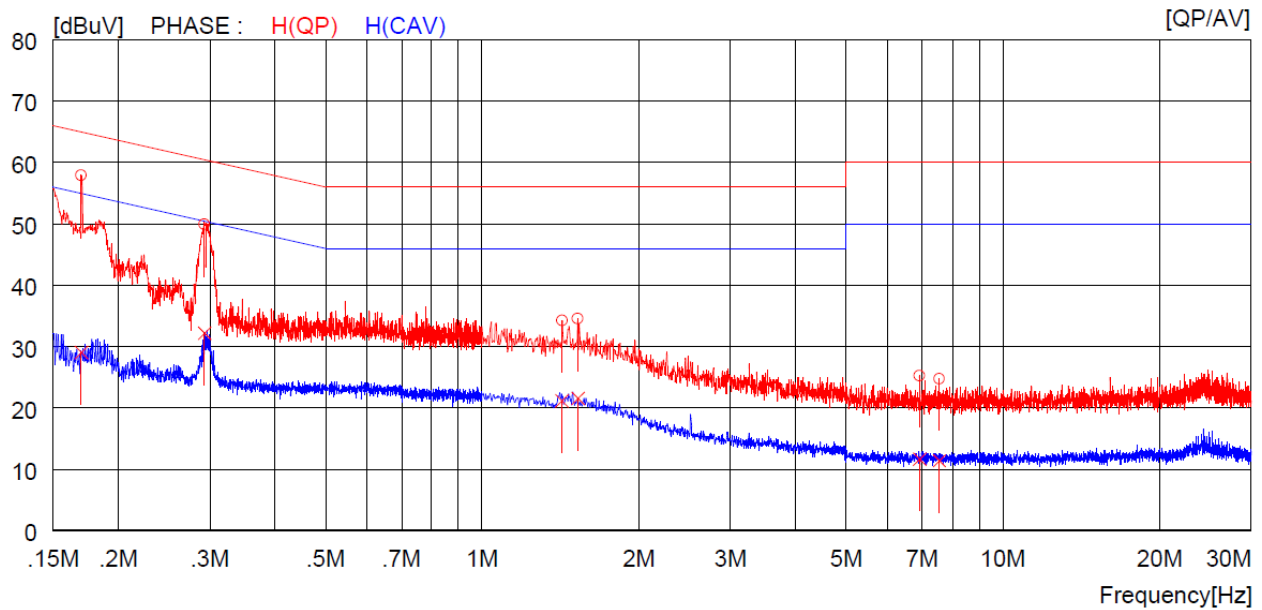

NO	FREQ [MHz]	READING		C.FACTOR [dB]	RESULT		LIMIT		MARGIN		PHASE
		QP [dBuV]	AV [dBuV]		QP [dBuV]	AV [dBuV]	QP [dBuV]	AV [dBuV]	QP [dBuV]	AV [dBuV]	
1	0.17000	47.9	----	10.0	57.9	----	65.0	----	7.1	----	H (QP)
2	0.29300	39.9	----	10.0	49.9	----	60.4	----	10.5	----	H (QP)
3	1.42400	24.2	----	10.1	34.3	----	56.0	----	21.7	----	H (QP)
4	1.52800	24.4	----	10.1	34.5	----	56.0	----	21.5	----	H (QP)
5	6.92500	15.0	----	10.3	25.3	----	60.0	----	34.7	----	H (QP)
6	7.55500	14.5	----	10.3	24.8	----	60.0	----	35.2	----	H (QP)
7	0.17000	----	19.0	10.0	----	29.0	----	55.0	----	26.0	H (CAV)
8	0.29300	----	22.2	10.0	----	32.2	----	50.4	----	18.2	H (CAV)
9	1.42400	----	11.1	10.1	----	21.2	----	46.0	----	24.8	H (CAV)
10	1.52800	----	11.5	10.1	----	21.6	----	46.0	----	24.4	H (CAV)
11	6.92500	----	1.4	10.3	----	11.7	----	50.0	----	38.3	H (CAV)
12	7.55500	----	1.1	10.3	----	11.4	----	50.0	----	38.6	H (CAV)

-. Tested Line : NEUTRAL LINE

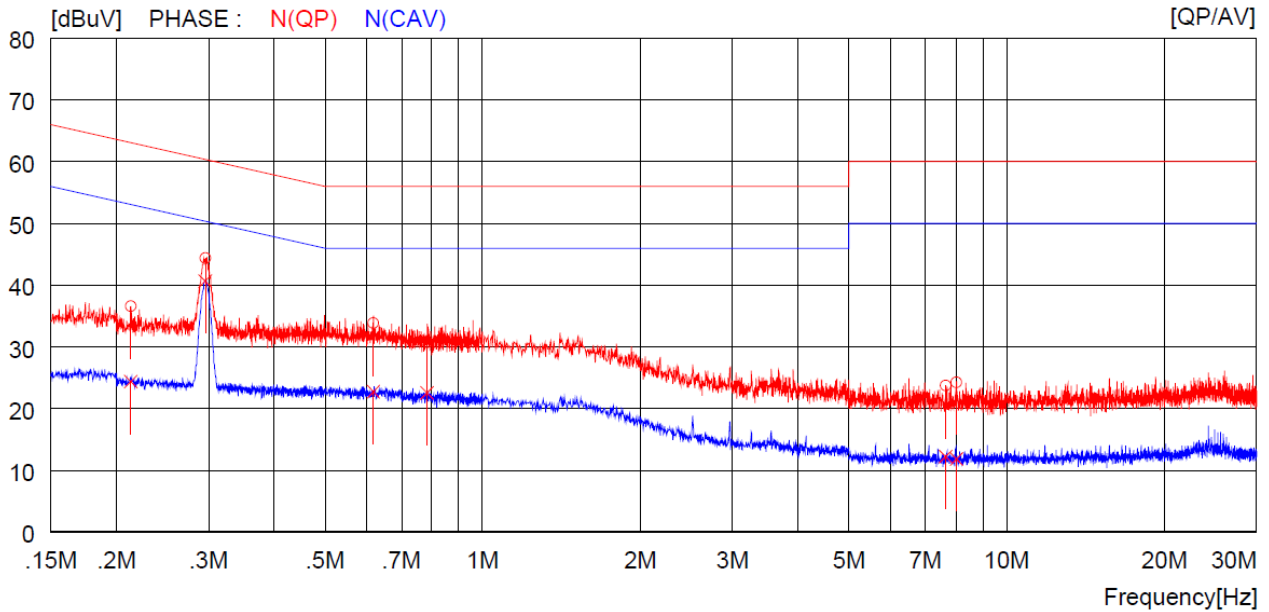

NO	FREQ [MHz]	READING		C.FACTOR [dB]	RESULT		LIMIT		MARGIN		PHASE
		QP [dBuV]	AV [dBuV]		QP [dBuV]	AV [dBuV]	QP [dBuV]	AV [dBuV]	QP [dBuV]	AV [dBuV]	
1	0.21300	26.6	----	10.0	36.6	----	63.1	----	26.5	----	N(QP)
2	0.29600	34.4	----	10.0	44.4	----	60.4	----	16.0	----	N(QP)
3	0.61900	23.7	----	10.1	33.8	----	56.0	----	22.2	----	N(QP)
4	0.78400	20.6	----	10.1	30.7	----	56.0	----	25.3	----	N(QP)
5	7.65000	13.4	----	10.3	23.7	----	60.0	----	36.3	----	N(QP)
6	8.03000	14.0	----	10.3	24.3	----	60.0	----	35.7	----	N(QP)
7	0.21300	----	14.4	10.0	----	24.4	----	53.1	----	28.7	N(CAV)
8	0.29600	----	30.7	10.0	----	40.7	----	50.4	----	9.7	N(CAV)
9	0.61900	----	12.7	10.1	----	22.8	----	46.0	----	23.2	N(CAV)
10	0.78400	----	12.5	10.1	----	22.6	----	46.0	----	23.4	N(CAV)
11	7.65000	----	2.0	10.3	----	12.3	----	50.0	----	37.7	N(CAV)
12	8.03000	----	1.6	10.3	----	11.9	----	50.0	----	38.1	N(CAV)

Remark: Margin (dB) = Limit – Level (Result)

The emission level in above table is included the transducer factor that means insertion loss (LISN), cable loss and attenuator.

Tested by: Min-Gu Ji / Assistant Manager

15.4.2 Test data for GSM1900

- Test Date : December 08, 2017
- Resolution bandwidth : 9 kHz
- Frequency range : 0.15 MHz ~ 30 MHz
- Tested Line : HOT LINE

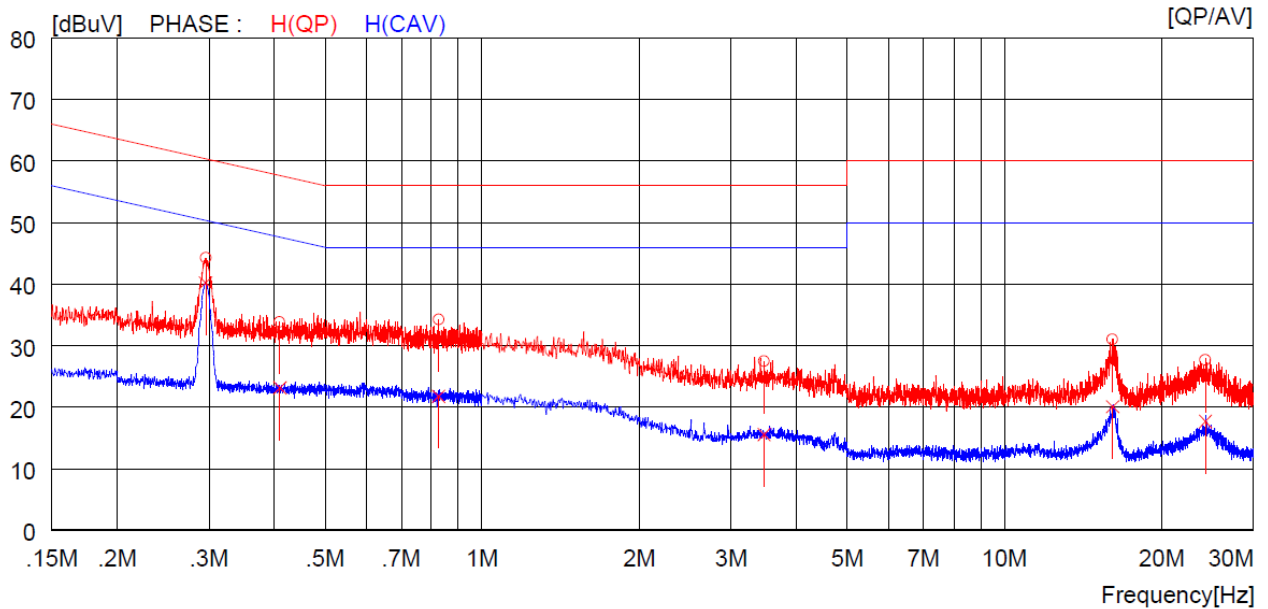

NO	FREQ [MHz]	READING		C. FACTOR [dB]	RESULT		LIMIT		MARGIN		PHASE
		QP [dBuV]	AV [dBuV]		QP [dBuV]	AV [dBuV]	QP [dBuV]	AV [dBuV]	QP [dBuV]	AV [dBuV]	
1	0.29600	34.2	----	10.0	44.2	----	60.4	----	16.2	----	H (QP)
2	0.41000	23.9	----	10.0	33.9	----	57.6	----	23.7	----	H (QP)
3	0.82600	24.2	----	10.1	34.3	----	56.0	----	21.7	----	H (QP)
4	3.46800	17.3	----	10.2	27.5	----	56.0	----	28.5	----	H (QP)
5	16.12000	20.4	----	10.6	31.0	----	60.0	----	29.0	----	H (QP)
6	24.26000	16.9	----	10.8	27.7	----	60.0	----	32.3	----	H (QP)
7	0.29600	----	30.2	10.0	----	40.2	----	50.4	----	10.2	H (CAV)
8	0.41000	----	13.2	10.0	----	23.2	----	47.6	----	24.4	H (CAV)
9	0.82600	----	11.7	10.1	----	21.8	----	46.0	----	24.2	H (CAV)
10	3.46800	----	5.4	10.2	----	15.6	----	46.0	----	30.4	H (CAV)
11	16.12000	----	9.5	10.6	----	20.1	----	50.0	----	29.9	H (CAV)
12	24.26000	----	6.9	10.8	----	17.7	----	50.0	----	32.3	H (CAV)

-. Tested Line : NEUTRAL LINE

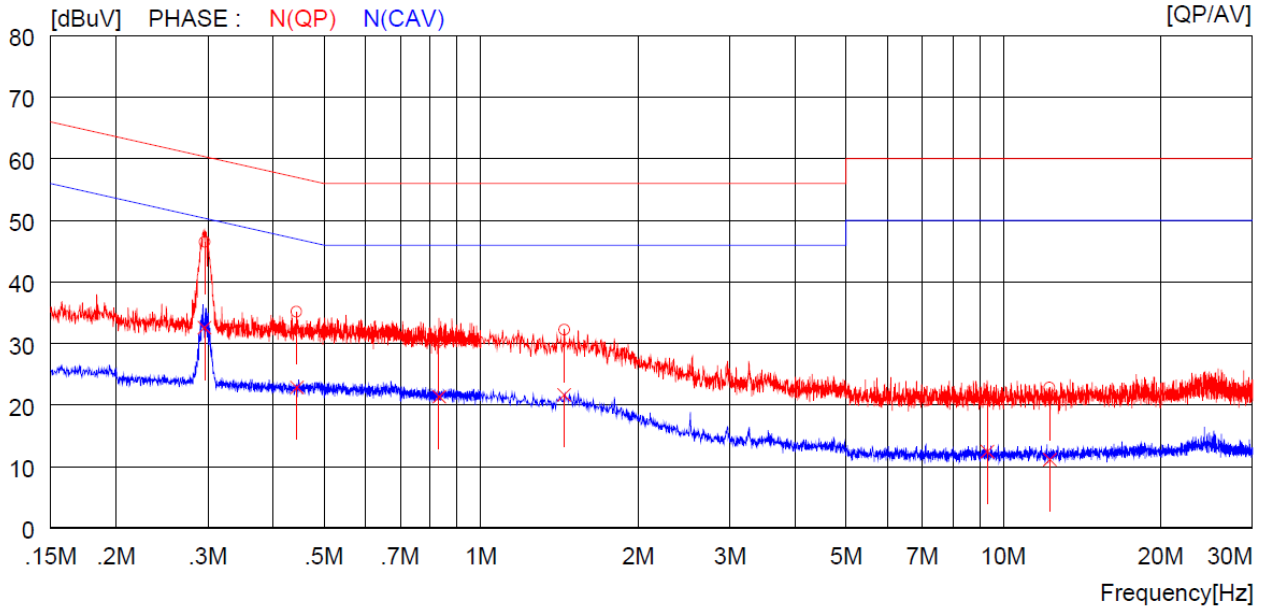

NO	FREQ [MHz]	READING		C.FACTOR [dB]	RESULT		LIMIT		MARGIN		PHASE
		QP [dBuV]	AV [dBuV]		QP [dBuV]	AV [dBuV]	QP [dBuV]	AV [dBuV]	QP [dBuV]	AV [dBuV]	
1	0.29600	36.5	----	10.0	46.5	----	60.4	----	13.9	----	N(QP)
2	0.44400	25.2	----	10.0	35.2	----	57.0	----	21.8	----	N(QP)
3	0.83100	20.3	----	10.1	30.4	----	56.0	----	25.6	----	N(QP)
4	1.44400	22.1	----	10.1	32.2	----	56.0	----	23.8	----	N(QP)
5	9.32000	10.5	----	10.4	20.9	----	60.0	----	39.1	----	N(QP)
6	12.28000	12.4	----	10.4	22.8	----	60.0	----	37.2	----	N(QP)
7	0.29600	----	22.6	10.0	----	32.6	----	50.4	----	17.8	N(CAV)
8	0.44400	----	12.9	10.0	----	22.9	----	47.0	----	24.1	N(CAV)
9	0.83100	----	11.3	10.1	----	21.4	----	46.0	----	24.6	N(CAV)
10	1.44400	----	11.6	10.1	----	21.7	----	46.0	----	24.3	N(CAV)
11	9.32000	----	2.1	10.4	----	12.5	----	50.0	----	37.5	N(CAV)
12	12.28000	----	0.8	10.4	----	11.2	----	50.0	----	38.8	N(CAV)

Remark: Margin (dB) = Limit – Level (Result)

The emission level in above table is included the transducer factor that means insertion loss (LISN), cable loss and attenuator.

Tested by: Min-Gu Ji / Assistant Manager