

EMC TEST REPORT

Type of equipment:	Base station
Model:	TDSBOBU3 (US version)
Marketing name:	Aranet PRO Plus LTE
Sub model:	-
Serial number:	367310305810
Applicant:	SAF Tehnika JSC
Manufacturer:	SAF Tehnika JSC
Test standard:	Testing carried out according to LEITC internal procedure P-17 Current tests are outside the scope of accreditation.
Test report no.:	LEITC-TR-23-043
Identification no.:	ID_1313_1
Testing laboratory:	SIA LEITC
Result summary:	-

The results applies only to the sample tested, according to the carried tests, which are included in this test report.
This test report shall not be reproduced expect in full, without the written approval of EMC Laboratory SIA LEITC.

Test responsible:	Gundars Ašmanis
Laboratory responsible:	Uldis Stūre
Date of issue:	05.04.2023.

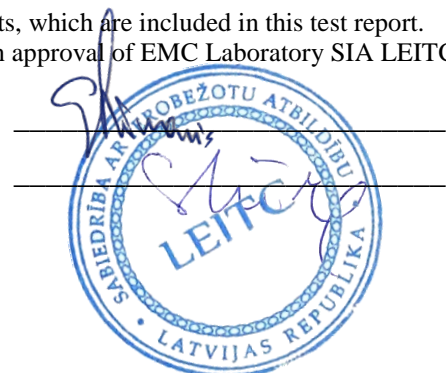

Contents

1. REVISION HISTORY	3
2. LABORATORY INFORMATION.....	4
3. CLIENT INFORMATION	5
4. SUMMARY OF TEST RESULTS	6
5. DESCRIPTION OF EQUIPMENT UNDER TEST	7
6. INSTRUMENTATION AND CALIBRATION	8
7. TEST PROCEDURES	9
8. TEST RESULTS	11
8.1 Gain	11
8.2 Gain	12
9. TEST PHOTOGRAPHS.....	13

1. REVISION HISTORY

Revision no.	Description	Date	Pages revised
00	First release.	05.04.2023.	N/A

2. LABORATORY INFORMATION



Latvian Electronic Equipment Testing Centre

Testing laboratory: SIA LEITC

Address: Azenes street 12, Riga, Latvia, LV-1048

Telephone number: +371 22001023

Contact Person: Uldis Stūre

E-mail: info@leitic.lv

uldis.sture@leitic.lv

andris.dzenis@leitic.lv

Web site: <http://www.leitic.lv>



3. CLIENT INFORMATION

Applicant: SAF Tehnika JSC

Address: Ganību dambis 24a, Rīga, Latvia, LV-1005

Telephone number: +371 67046840

Contact Person: Andrejs Arhipovs

E-mail: andrejs.arhipovs@saftehnika.com

Web: <http://saftehnika.com/>

Manufacturer: SAF Tehnika JSC

Address: Ganību dambis 24a, Rīga, Latvia, LV-1005

Telephone number: +371 67046840

Contact Person: Andrejs Arhipovs

E-mail: andrejs.arhipovs@saftehnika.com

Web: <http://saftehnika.com/>

4. SUMMARY OF TEST RESULTS

Standard:	Internal procedure P-17				
Title:	<i>Integrated antenna gain measurement using Friis free space equation</i>				
Reference Standard:	-				
Title:	-				
No.					
Measurement type		Reference standard		Applicability	Result
1.	Gain	-		Y	N/A
Notes: Y- applied; N/A – not applicable.					
Deviations from standard specification: no deviations from the test standards.					

5. DESCRIPTION OF EQUIPMENT UNDER TEST

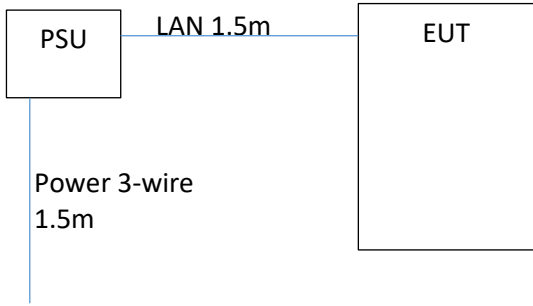
5.1 Description of EUT						
LEITC identification no.: ID_1313_1						
Base station						
No.	EUT	Model	Serial No.	Manufacturer		
1.	Base station	TDSBOBU3 (US version)	367310305810	SAF Tehnika JSC		
5.2 Peripherals and associated equipment						
No.	Description	Model	Serial No.	Manufacturer		
1.	PSU	POE15M-1AFE	-	PHIHONG		
5.3 Cables used during the testing						
No.	Cable type	Shielded	Ferrite	Length used during test	Connection 1	Connection2
1.	LAN	<input checked="" type="checkbox"/>	<input type="checkbox"/>	1.5m	EUT	PSU
2.	Power 3-wire	<input type="checkbox"/>	<input type="checkbox"/>	1.5m	PSU	Mains network
5.4 EUT configuration						
Device was configured for continuous transmission.						
Transmitted power at the integrated antenna input $P_{tx} = -1\text{dBm}$ (data provided by manufacturer).						
5.4.1 Operating modes/load						
1.	Turned on in continuous transmission mode.					
5.4.2 Modification state						
1.	No modification made.					
5.4.3 Radio frequency transmitters incorporated in EUT						
No.	Description	Frequency	Modulation			
1.	Radio module	923.2MHz	CW			
 <pre> graph LR PSU[PSU] --- LAN[LAN 1.5m] --- EUT[EUT] PSU --- Power[Power 3-wire 1.5m] </pre>						

6. INSTRUMENTATION AND CALIBRATION

Equipment and EUT during the tests are operated in temperature range of 21⁰ to 25⁰C, humidity range of 40% to 60%, if not mentioned more precisely next to measurement data.

The measuring equipment utilized to perform the tests documented in this report has been calibrated once a year or in accordance with manufacturer's recommendations or quality manager deliverance and it is traceable under the ISO/IEC 17025 to international or national standards. Equipment has been calibrated by accredited calibration laboratories.

The following list contains measurement equipment used for testing. The equipment conforms to the requirements of CISPR 16-1 and other standard requirements.

Radiated emissions				
Device	Manufacturer	Model	Serial number	Notes
Antenna	Rohde & Schwarz	HL562E	102093	Certificate of calibration No. 200583 D-K-15195-01-00; 15.04.2021
Receiver	Rohde & Schwarz	ESIB26	1088.7490K26	Certificate of calibration 202204692.00 (26.01.2023)
Turntable	FRANKONIA	FCTAM01	-	Not applicable.
Test site	FRANKONIA	SAC3	-	Not applicable.
Software for EMC measurements EMC32	Rohde & Schwarz	Version 8.53.0	-	Not applicable.

7. TEST PROCEDURES

P-17 Integrated antenna gain measurement using Friis free space equation

Assuming that semianechoic chamber is fulfilling free space conditions and antennas are located in far field, gain is calculated based on Friis equation:

$$P_{rx} = P_{tx} G_{tx} G_{rx} \left(\frac{\lambda}{4\pi d} \right)^2$$

where

P_{rx} – Power at receiving antenna output;

P_{tx} – Power at transmitting antenna input;

G_{rx} – Receiving antenna gain;

G_{tx} – Transmitting antenna gain;

λ – wavelength, where $\lambda = c/f$, c = speed of light, f = frequency;

d – Distance, between two antennas;

c – Speed of light in vacuum 299.972458×10^6 m/s;

Gain of the transmitting antenna can be calculated as follows:

$$G_{tx} = \frac{P_{rx}}{P_{tx} G_{rx}} \left(\frac{4\pi d}{\lambda} \right)^2$$

Or in terms of dB

$$G_{tx} = P_{rx} - P_{tx} - G_{rx} - 20 \log_{10} \left(\frac{\lambda}{4\pi d} \right)^2$$

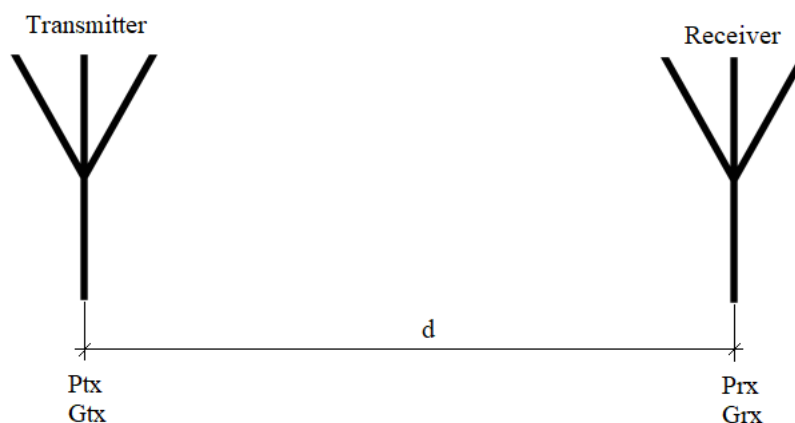

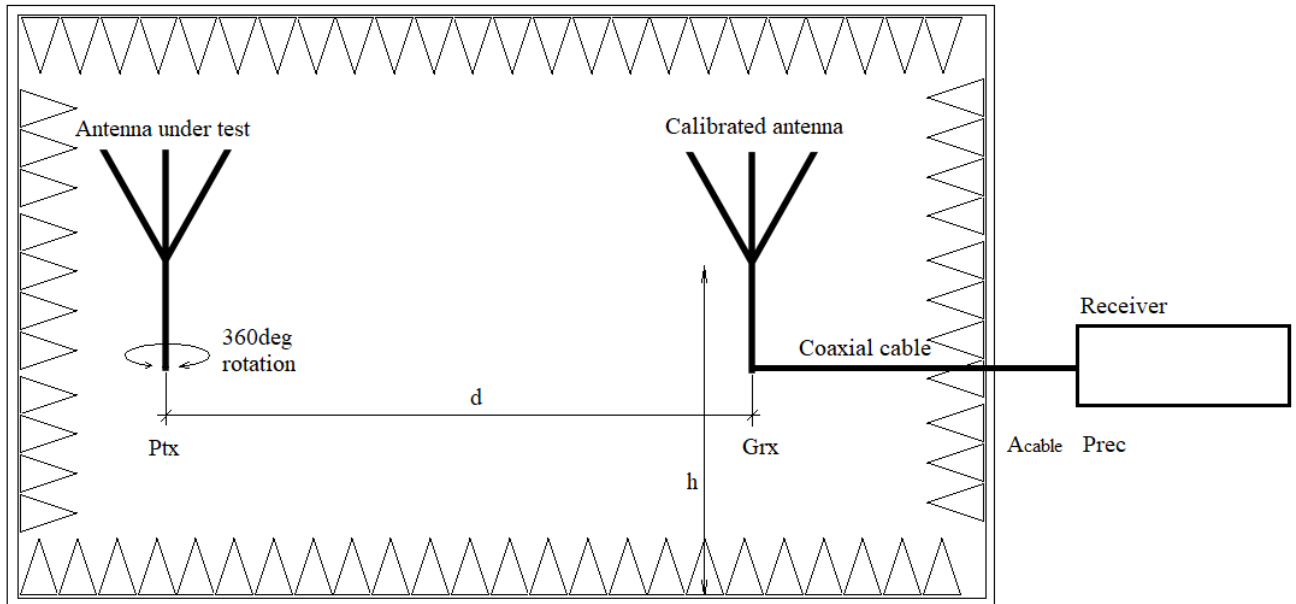

Antenna under test (transmitting antenna) is integrated in IoT product that has an internal RF power source providing power P_{tx} . Calibrated receiving antenna with known G_{rx} is connected to receiver via coaxial cable with cable loss A_{cable} . Receiver reading P_{rec} . Both antennas are located at the same height above reference ground plane h . Antenna under test is rotated 360deg to measure antenna pattern. Measurement antenna positioning (polarization) is changed during the measurements to measure gain in vertical and horizontal polarization.



Gain of antenna under test is calculated as follows:

$$G_{tx} = P_{rec} + A_{cable} - P_{tx} - G_{rx} - 20 \log_{10} \left(\frac{\lambda}{4\pi d} \right)^2$$

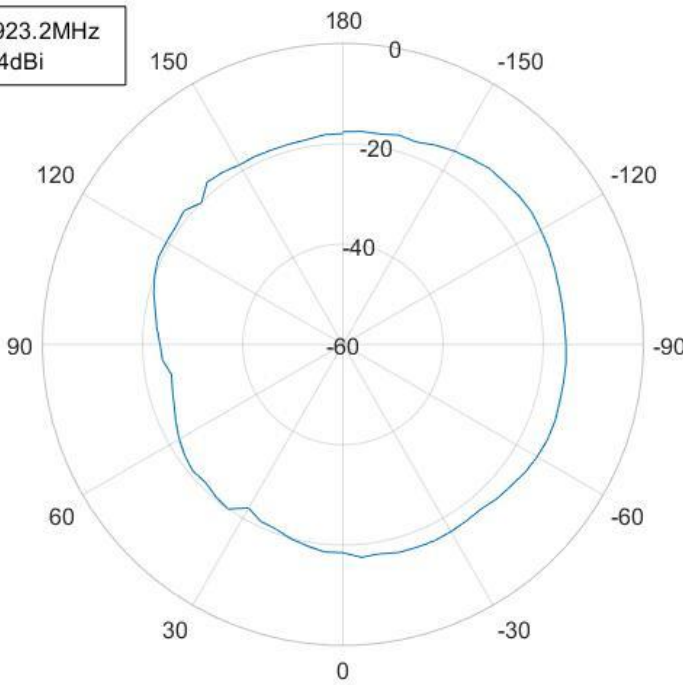
8. TEST RESULTS

8.1 Gain		Plot			
<div style="border: 1px solid black; padding: 5px; display: inline-block; margin-bottom: 10px;"> Frequency = 923.2MHz MaxGain = -14dBi </div> 					
					
Date:	05.04.2023.	Test engineer:	Gundars Asmanis		
Method:	P-17	Port:	Enclosure		
Notes: Device positioning coincide gain polar plot.					
Chamber:	SAC3	Height:	1m	Mode:	1
Distance:	3.6m	Polarization:	V	Mod. State:	1
Angle:	-180°..+180°	File:	TransmitterGain_Vpol_Aranet4_923_2_N1_Vpol		

The test results relate only to the sample tested. This test report shall not be reproduced except in full, without the written approval of SIA LEITC.

	8.2 Gain	Plot	
--	-----------------	-------------	--

Frequency = 923.2MHz
MaxGain = -22.6dBi

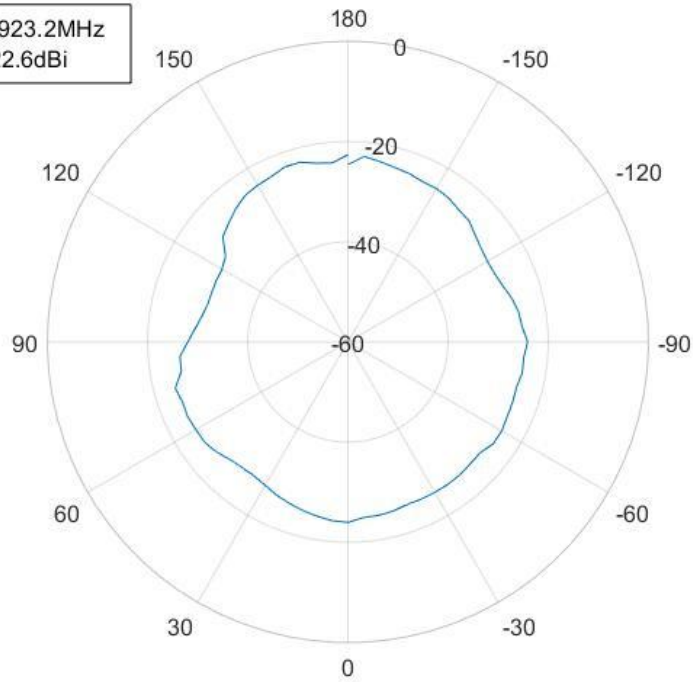

Date:	05.04.2023.	Test engineer:	Gundars Asmanis
Method:	P-17	Port:	Enclosure
Notes: Device positioning coincide gain polar plot.			
Chamber:	SAC3	Height:	1m
Distance:	3.6m	Polarization:	H
Angle:	-180°..+180°	File:	TransmitterGain_Vpol_Aranet4_923_2_N2_Hpol
		Mode:	1
		Mod. State:	1

The test results relate only to the sample tested. This test report shall not be reproduced except in full, without the written approval of SIA LEITC.

9. TEST PHOTOGRAPHS

EUT-equipment under test:

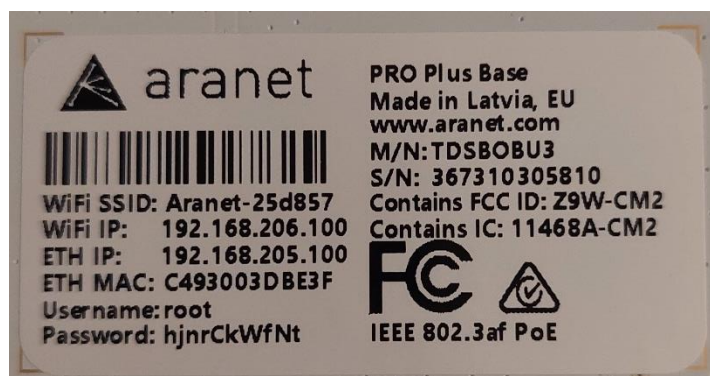
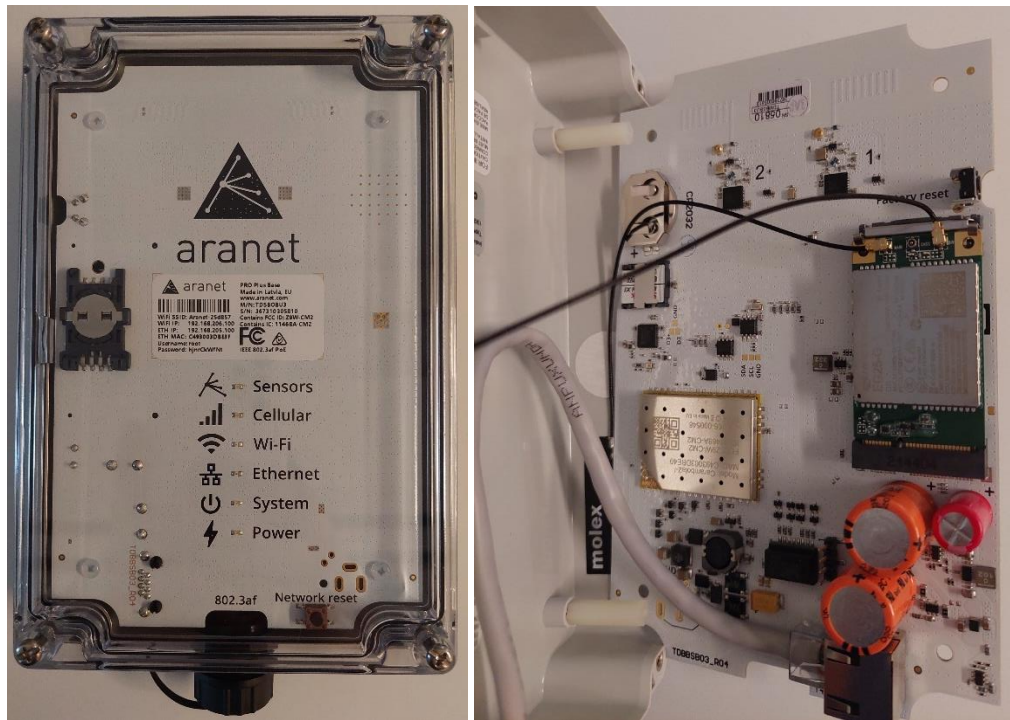

Measurements in SAC

