

# ROGERS LABS, INC.

4405 West 259<sup>th</sup> Terrace  
Louisburg, KS 66053  
Phone / Fax (913) 837-3214

## Application For Grant of Certification Title 47CFR, PART 15C - Intentional Radiators 47CFR Paragraph 15.247 and Industry Canada RSS-247 Issue 2 and RSS-GEN Issue 5

PMN: Aranet4 PRO  
HVIN's: TDSPC0U3.042, TDSPC0U3.043, TDSPC0U3.044

902-928 MHz (DTS)  
Hybrid Digital Transmission System

FCC ID: W9Z-A4MK3PRO  
IC: 8855A-A4MK3PRO

## SAF Tehnika AS

24a, Ganibu dambis  
Riga Latvia LV-1005

FCC Designation: US5305  
IC Test Site Registration: 3041A-1

Test Report Number: 211216

Test Date: December 16, 2021

Authorized Signatory: *Scot D. Rogers*

Scot D. Rogers  
Rogers Labs, Inc.

This report shall not be reproduced except in full, without the written approval of the laboratory.  
This report must not be used by the client to claim product certification, approval, or endorsement by NVLAP, NIST, or any agency of the U.S. Government.

Rogers Labs, Inc.  
4405 W. 259th Terrace  
Louisburg, KS 66053  
Phone/Fax: (913) 837-3214  
Revision 1

SAF Tehnika AS  
PMN: Aranet4 PRO HVIN: TDSPC0U3.042, TDSPC0U3.043, TDSPC0U3.044  
Test: 211216 FCC ID: W9Z-A4MK3PRO IC: 8855A-A4MK3PRO  
Test to: CFR47 15C, RSS-Gen RSS-247 Date: February 1, 2022  
File: SAF A4MK3PRO DSS TstRpt 211216 Page 1 of 49

S/N's: 329970010628 - 329970010630

## Table of Contents

<b>TABLE OF CONTENTS.....</b>	<b>2</b>
<b>REVISIONS.....</b>	<b>4</b>
<b>EXECUTIVE SUMMARY .....</b>	<b>5</b>
<b>OPINION / INTERPRETATION OF RESULTS .....</b>	<b>5</b>
<b>EQUIPMENT TESTED.....</b>	<b>5</b>
<b>Equipment Function .....</b>	<b>6</b>
<b>Equipment Operations.....</b>	<b>7</b>
<b>Equipment Configuration.....</b>	<b>8</b>
<b>APPLICATION FOR CERTIFICATION.....</b>	<b>9</b>
<b>APPLICABLE STANDARDS &amp; TEST PROCEDURES .....</b>	<b>10</b>
<b>STATEMENT OF MODIFICATIONS AND DEVIATIONS .....</b>	<b>10</b>
<b>TESTING PROCEDURES .....</b>	<b>11</b>
<b>AC Line Conducted Emission Test Procedure .....</b>	<b>11</b>
<b>Radiated Emission Test Procedure.....</b>	<b>11</b>
<b>Antenna-Port Conducted Emission Test Procedure .....</b>	<b>11</b>
Diagram 1 Test arrangement for radiated emissions of tabletop equipment.....	12
Diagram 2 Test arrangement for radiated emissions tested on Open Area Test Site (OATS).....	13
Diagram 3 Test arrangement for Antenna Port Conducted emissions .....	13
<b>TEST SITE LOCATIONS .....</b>	<b>14</b>
<b>UNITS OF MEASUREMENTS .....</b>	<b>14</b>
<b>ENVIRONMENTAL CONDITIONS.....</b>	<b>14</b>
<b>INTENTIONAL RADIATORS.....</b>	<b>15</b>
<b>Antenna Requirements .....</b>	<b>15</b>

**Restricted Bands of Operation.....15**

Table 1 LoRa Radiated Emissions Data in Restricted Frequency Bands ..... 16

**Summary of Results for Radiated Emissions in Restricted Bands .....16**

**AC Line Conducted Emissions Procedure .....17**

**General Radiated Emissions Procedure .....17**

Table 2 General Radiated Emissions Data ..... 18

**Summary of Results for General Radiated Emissions .....18**

**Operation in the Band 902-928 MHz (LoRa).....19**

Figure 1 LoRa (M-Mode) Plot of Transmitter Emissions in Operational Frequency Band..... 22

Figure 2 LoRa (M-Mode) Plot of Lower Band Edge..... 23

Figure 3 LoRa (M-Mode) Plot of Upper Band Edge ..... 24

Figure 4 LoRa (M-Mode) Plot of Transmitter 6-dB Occupied Bandwidth ..... 25

Figure 5 LoRa (M-Mode) Plot of Transmitter 99% Occupied Bandwidth ..... 26

Figure 6 LoRa (M-Mode) Plot of Power Spectral Density ..... 27

Figure 7 LoRa (M-Mode) Plot of Output Power ..... 28

Figure 8 LoRa (M-Mode) Plot of Out of Band Emissions ..... 29

Figure 9 LoRa (P-Mode) Plot of Transmitter Emissions in Operational Frequency Band ..... 30

Figure 10 LoRa (P-Mode) Plot of Lower Band Edge..... 31

Figure 11 LoRa (P-Mode) Plot of Upper Band Edge ..... 32

Figure 12 LoRa (P-Mode) Plot of Transmitter 20-dB Occupied Bandwidth..... 33

Figure 13 LoRa (P-Mode) Plot of Transmitter 99% Occupied Bandwidth ..... 34

Figure 14 LoRa (P-Mode) Plots of Power Spectral Density ..... 35

Figure 15 LoRa (P-Mode) Plot of Channel Separation..... 36

Figure 16 LoRa (P-Mode) Plot of Dwell Time on channel ..... 37

Figure 17 LoRa (P-Mode) Plot of Output Power..... 38



NVLAP Lab Code 200087-0

Figure 18 LoRa (P-Mode) Plot of Output Power.....39

Figure 19 LoRa (P-Mode) Plot of Output Power.....40

Figure 20 LoRa (P-Mode) Plot of Out of Band Emissions.....41

**Transmitter Emissions Data.....42**

Table 3 LoRa Transmitter Radiated Emission Worst-case Data .....42

Table 4 Transmitter Antenna Port Data .....43

**Summary of Results for Transmitter Radiated Emissions of Intentional Radiator.....43**

**ANNEX..... 44**

**Annex A Measurement Uncertainty Calculations.....45**

**Annex B Test Equipment.....46**

**Annex C Rogers Qualifications.....48**

**Annex D Laboratory Certificate of Accreditation.....49**

## Revisions

Revision 1 Issued February 1, 2022

Rogers Labs, Inc.  
 4405 W. 259th Terrace  
 Louisburg, KS 66053  
 Phone/Fax: (913) 837-3214  
 Revision 1

SAF Tehnika AS  
 PMN: Aranet4 PRO  
 Test: 211216  
 Test to: CFR47 15C, RSS-Gen RSS-247  
 File: SAF A4MK3PRO DSS TstRpt 211216

S/N's: 329970010628 - 329970010630  
 HVIN: TDSPC0U3.042, TDSPC0U3.043, TDSPC0U3.044  
 IC: 8855A-A4MK3PRO  
 Date: February 1, 2022  
 Page 4 of 49

## Executive Summary

The following information is submitted for consideration in obtaining Grant of Certification for License Exempt Hybrid Digital Transmission System Intentional Radiator operating under Title 47 Code of Federal Regulations (47CFR) Paragraph 15.247 and Industry Canada RSS-GEN, Issue 5, and RSS-247 Issue 2, operation in the 902-928 MHz band.

Name of Applicant: SAF Tehnika AS  
24a, Ganibu dambis  
Riga Latvia LV-1005

FCC ID: W9Z-A4MK3PRO IC: 8855A-A4MK3PRO

PMN: Aranet4 PRO HVIN: TDSPC0U3.043; TDSPC0U3.044 (note: Numbers “0” are numeric zeros)

Antenna: 915 MHz, PIFA (0 dBi)

Frequency Range: LoRa - 917.3-923.5 MHz

LoRa M-Mode, Output Power 0.001 W, 99% Occupied bandwidth 682.0 kHz

LoRa P-Mode, Output Power 0.030 W, 20-dB Occupied bandwidth 139.5 kHz

## Opinion / Interpretation of Results

Tests Performed	Margin (dB)	Results
Restricted Bands Emissions per 47CFR 15.205, RSS-GEN	-19.5	Complies
AC Line Emissions per 47CFR 15.207, RSS-GEN	N/A	Complies
General Emissions as per 47CFR 15.209, RSS-GEN	-13.6	Complies
Harmonic Emissions per 47CFR 15.247, RSS-247	-19.5	Complies
Power Spectral Density per 47CFR 15.247, RSS-247	-5.4	Complies

## Equipment Tested

<u>Equipment</u>	<u>Model / PN</u>	<u>Serial Number</u>
EUT #1 (Radiated Production)	TDSPC0U3.042	329970010628
EUT #2 (Radiated Tx)	TDSPC0U3.042	329970010629
EUT #3 (Antenna port connector)	TDSPC0U3.042	329970010630

Test results in this report relate only to the items tested.

- Antenna: Omni-directional, Gain: 0-dBi
- Software version of “typical” v0.4.11 and higher
- Software version of “modified for testing” v0.4.11

## ***Equipment Function***

The Equipment Under Test (EUT) provides sensor circuitry to monitor environmental conditions. The design may be provided using different CO<sub>2</sub> sensors interfaced with the identical transmitter board. Each version of sensor is designated a unique HVIN (TDSPC0U3.042, TDSPC0U3.043, TDSPC0U3.044). The design incorporates radio transceivers providing wireless operation with compatible 902-928 MHz LoRa (Long Rang) devices as well as a BLE (Bluetooth<sup>®</sup> Low Energy) module (FCC ID: 2APD9-RSL10SIP, IC: 23763-RSL10SIP) operating in the 2402-2480 MHz. The LoRa transmitter was tested for compliance as a Hybrid Digital Transmission System employing a combination of both frequency hopping and digital modulation techniques. The BLE module was operational during testing. Three test samples were provided for testing purposes samples 1 and 2 represented production manufactured product with integral antenna and sample 3 was modified replacing the integral antenna with a 50-ohm antenna port connector. Test samples 2 and 3 were also modified with the addition of a push button switch and test software to enable transmit operation on lowest, middle, and highest operating channels. Samples 2 and 3 operated with special test software which provided testing personnel the ability to operate the transmitters in defined modes. The LoRa transmitter may operate one of two modes, either M-mode (500 kHz wide channel) or P-mode (125 kHz wide channel). LoRa operation in the M-mode operates as a Digital Modulation Transmission System and P-Mode employs a combination of both frequency hopping and Digital Modulation Techniques. Each operational mode was tested for compliance as documented in this report. The design operates from two (2) LR6 (AA) replaceable batteries only and offers no provision for alternate power source. Test samples were provided with test software to enable transmit operation on lowest, middle, and highest operating channels. The test software provided operation of the transmitter at 100% duty cycle for testing. For testing purposes, each test sample received power from new replaceable LR6 batteries and configured to operate in available modes. The equipment was tested for emissions compliance using the available configurations with the worst-case data presented. Test results in this report relate only to the products described in this report.

## **Equipment Operations**

The Aranet products have distinct operation modes, which use the following radio frequency channels:

- Pairing mode utilized by all of the products (TX and RX) (M-mode)
  - 923.2 MHz @ 500 kHz
  
- Aranet4 PRO system mode utilized by sensors (TX) and Aranet Pro (RX) (P-mode)
  - 917.3 MHz; 922.9 MHz @ 125kHz
  - 917.5 MHz; 923.1 MHz @ 125kHz
  - 917.7 MHz; 923.3 MHz @ 125kHz
  - 917.9 MHz; 923.5 MHz @ 125kHz

Aranet4 PRO base stations choose their initial operational channel randomly when the device is first powered up.

## Equipment Configuration

- 1) EUT 1 (Production sample) operating from replaceable LR6 (AA) internal battery



- 2) EUT 2 operating from replaceable LR6 (AA) internal battery



- 3) EUT 3 (Antenna Port Unit) operating from replaceable LR6 (AA) internal battery

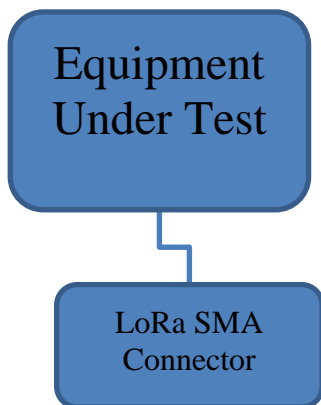



## Application for Certification

- (1) Manufacturer: SAF Tehnika AS  
24a, Ganibu dambis  
Riga Latvia LV-1005
- (2) Identification: M/N: Aranet4 Pro, HVIN: TDSPC0U3.042, TDSPC0U3.043, TDSPC0U3.044  
FCC ID: W9Z-A4MK3PRO IC: 8855A-A4MK3PRO
- (3) Instruction Book:  
Refer to Exhibit for Instruction Manual.
- (4) Description of Circuit Functions:  
Refer to Exhibit of Operational Description.
- (5) Block Diagram with Frequencies:  
Refer to Exhibit of Operational Description.
- (6) Report of Measurements:  
Report of measurements follows in this Report.
- (7) Photographs: Construction, Component Placement, etc.:  
Refer to Exhibit for photographs of equipment.
- (8) List of Peripheral Equipment Necessary for operation. The equipment operates from direct current power supplied from replaceable LR6 (AA) batteries and provides no other interface options as presented in this filing. The EUT offers no other connection ports than those presented in this filing.
- (9) Transition Provisions of 47CFR 15.37 are not requested.
- (10) Not Applicable. The unit is not a scanning receiver.
- (11) Not Applicable. The EUT does not operate in the 59 – 64 GHz frequency band.
- (12) The equipment is not software defined and this section is not applicable.
- (13) Applications for certification of U-NII devices in the 5.15-5.35 GHz and the 5.47-5.85 GHz bands must include a high-level operational description of the security procedures that control the radio frequency operating parameters and ensure that unauthorized modifications cannot be made. This requirement is not applicable to his DTS device.
- (14) Contain at least one drawing or photograph showing the test set-up for each of the required types of tests applicable to the device for which certification is requested. These drawings or photographs must show enough detail to confirm other information contained in the test report. Any photographs used must be focused originals without glare or dark spots and must clearly show the test configuration used. This information is provided in this report and Test Setup Exhibits provided with the application filing.

## Applicable Standards & Test Procedures

The following information is submitted in accordance with the eCFR Federal Communications Code of Federal Regulations, dated December 16, 2021, Part 2, Subpart J, Paragraphs 2.907, 2.911, 2.913, 2.925, 2.926, 2.1031 through 2.1057, applicable parts of paragraph 15, Part 15C Paragraph 15.247, Industry Canada RSS-247 Issue 2, and RSS-GEN Issue 5. This equipment operates as Hybrid Digital Transmission System. Hybrid systems are those that employ a combination of both frequency hopping and digital modulation techniques. The frequency hopping operation of the hybrid system, with the direct sequence or digital modulation operation turned-off, provides an average time of occupancy on any frequency not exceeding 0.4 seconds within a time period in seconds equal to the number of hopping frequencies employed multiplied by 0.4. The power spectral density conducted from the intentional radiator to the antenna due to the digital modulation operation of the hybrid system, with the frequency hopping operation turned off, remains below the 8 dBm in any 3-kHz band during any time interval of continuous transmission. Test procedures used are as defined in 558074 D01 15.247 Meas Guidance v05r02 and ANSI C63.10-2013.

## Statement of Modifications and Deviations

No modifications to the EUT were required for the design to demonstrate compliance with the 47CFR Part 15C, RSS-Gen, and RSS-247 emission requirements. There were no deviations to the specifications.

## Testing Procedures

### ***AC Line Conducted Emission Test Procedure***

The design operates solely from direct current power provided from LR6 (AA) 1.5-volt batteries. The design offers no provision for connection with Utility AC power system and is therefore exempt from AC Line conducted emissions testing.

### ***Radiated Emission Test Procedure***

Radiated emissions testing was performed as required in 47CFR 15, RSS-247 and specified in ANSI C63.10-2013. The EUT was placed on a rotating 0.9 x 1.2-meter platform, elevated as required above the ground plane at a distance of 3 meters from the FSM antenna. EMI energy was maximized by equipment placement permitting orientation in three orthogonal axes, raising, and lowering the FSM antenna, changing the antenna polarization, and by rotating the turntable. Each emission was maximized before data was taken using a spectrum analyzer. The frequency spectrum from 9 kHz to 25,000 MHz was searched during preliminary investigation. Refer to diagrams one and two showing typical test arrangement and photographs in the test setup exhibits for specific EUT placement during testing.

### ***Antenna-Port Conducted Emission Test Procedure***

The EUT was assembled as required for operation and placed on a benchtop. This configuration provided the ability to connect test equipment to the provided test antenna port. Antenna Port conducted emissions testing was performed as presented in the regulations and specified in ANSI C63.10-2013. Antenna port conducted emissions testing was completed on a laboratory bench in a shielded room. The active antenna port of the device was connected to appropriate attenuation and the spectrum analyzer. Refer to diagram three showing typical test arrangement and photographs in the test setup exhibits for specific EUT placement during testing.

**Diagram 1 Test arrangement for radiated emissions of tabletop equipment**

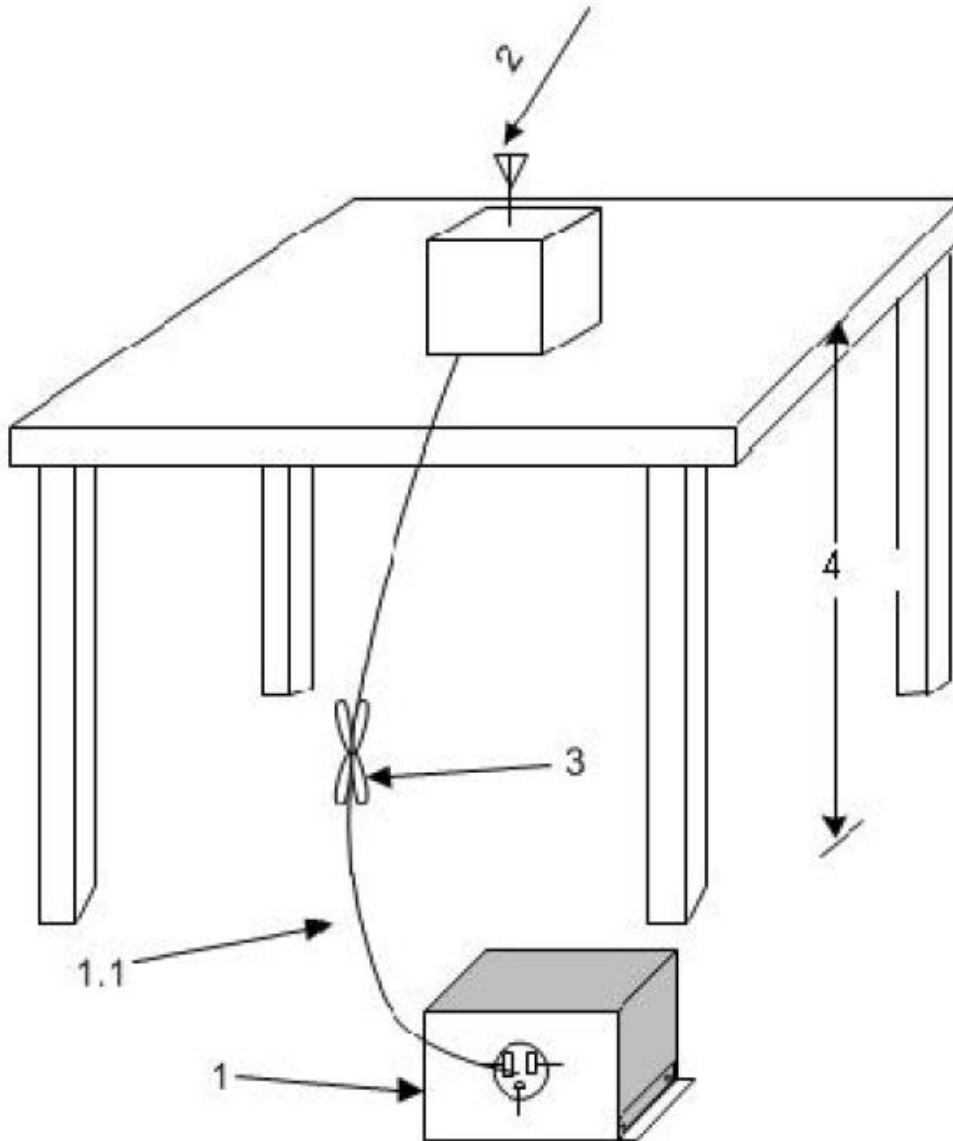

1. A LISN is optional for radiated measurements between 30 MHz and 1000 MHz but not allowed for measurements below 30 MHz and above 1000 MHz (see 6.3.1). If used, then connect EUT to one LISN. Unused LISN measuring port connectors shall be terminated in 50Ω loads. The LISN may be placed on top of, or immediately beneath, the reference ground plane (see 6.2.2 and 6.2.3.2).
  - 1.1—LISN spaced at least 80 cm from the nearest part of the EUT chassis.
2. Antenna can be integral or detachable, depending on the EUT (see 6.3.1).
3. Interconnecting cables that hang closer than 40 cm to the ground plane shall be folded back and forth in the center forming a bundle 30 cm to 40 cm long (see 6.3.1).
4. For emission measurements at or below 1 GHz, the table height shall be 80 cm. For emission measurements above 1 GHz, the table height shall be 1.5 m for measurements, except as otherwise specified (see 6.3.1 and 6.6.3.1).

**Diagram 2 Test arrangement for radiated emissions tested on Open Area Test Site (OATS)**

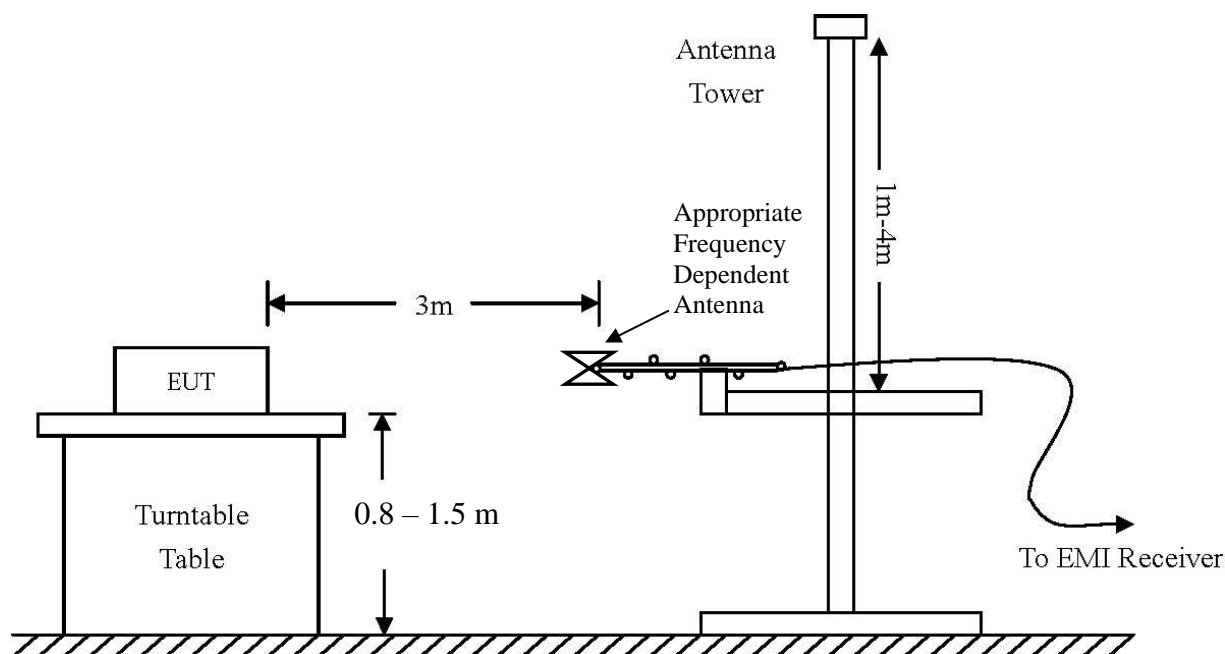

**Diagram 3 Test arrangement for Antenna Port Conducted emissions**

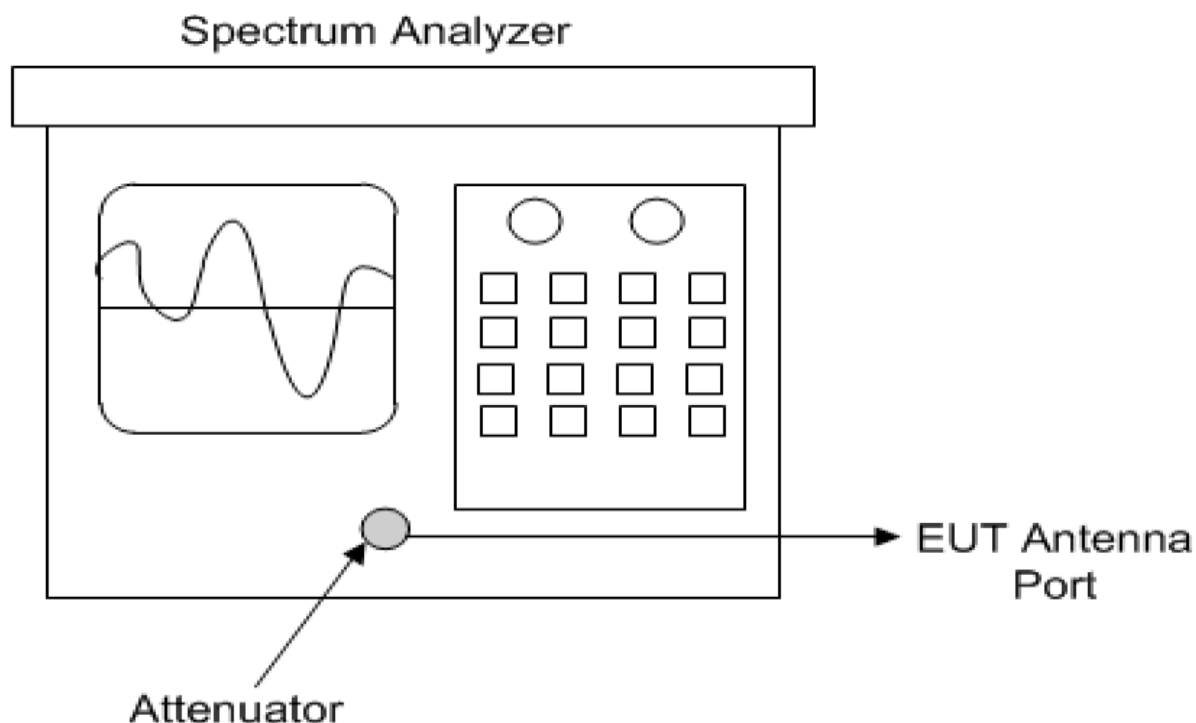

## Test Site Locations

Conducted EMI	AC line conducted emissions testing performed in a shielded screen room located at Rogers Labs, Inc., 4405 West 259 <sup>th</sup> Terrace, Louisburg, KS
Antenna port	Antenna port conducted emissions testing was performed in a shielded screen room located at Rogers Labs, Inc., 4405 West 259 <sup>th</sup> Terrace, Louisburg, KS
Radiated EMI	The radiated emissions tests were performed at the 3 meters, Open Area Test Site (OATS) located at Rogers Labs, Inc., 4405 West 259 <sup>th</sup> Terrace, Louisburg, KS

Registered Site information: FCC Site: US5305, ISED: 3041A, CAB Identifier: US0096

NVLAP Accreditation Lab code 200087-0

## Units of Measurements

Conducted EMI	Data presented in dB $\mu$ V; dB referenced to one microvolt
Antenna port Conducted	Data is in dBm; dB referenced to one milliwatt
Radiated EMI	Data presented in dB $\mu$ V/m; dB referenced to one microvolt per meter

Note: Radiated limit may be expressed for measurement in dB $\mu$ V/m when the measurement is taken at a distance of 3 or 10 meters. Data taken for this report was taken at distance of 3 meters. Sample calculation demonstrates corrected field strength reading for Open Area Test Site using the measurement reading and correcting for receive antenna factor, cable losses, and amplifier gains.

Sample Calculation:

RFS = Radiated Field Strength, FSM = Field Strength Measured

A.F. = Receive antenna factor, Losses = attenuators/cable losses, Gain = amplification gains

$RFS (dB\mu V/m @ 3m) = FSM (dB\mu V) + A.F. (dB/m) + Losses (dB) - Gain (dB)$

## Environmental Conditions

Ambient Temperature	20.7° C
Relative Humidity	41%
Atmospheric Pressure	1022.8 mb

Rogers Labs, Inc. 4405 W. 259th Terrace Louisburg, KS 66053 Phone/Fax: (913) 837-3214 Revision 1	SAF Tehnika AS PMN: Aranet4 PRO Test: 211216 Test to: CFR47 15C, RSS-Gen RSS-247 File: SAF A4MK3PRO DSS TstRpt 211216	S/N's: 329970010628 - 329970010630 HVIN: TDSPC0U3.042, TDSPC0U3.043, TDSPC0U3.044 IC: 8855A-A4MK3PRO Date: February 1, 2022 Page 14 of 49
--	---	---

## Intentional Radiators

The following information is submitted for demonstration of compliance with the requirements of 47CFR Subpart C paragraph 15.247, and Industry Canada RSS-247 and RSS-Gen.

### ***Antenna Requirements***

The EUT incorporates integral antenna system and offers no provision for connection to alternate antenna system. The antenna connection point complies with the unique antenna connection requirements. There are no deviations or exceptions to the specification.

### ***Restricted Bands of Operation***

Spurious emissions falling in the restricted frequency bands of operation were measured at the OATS. The EUT utilizes frequency, determining circuitry, which generates harmonics falling in the restricted bands. Emissions were investigated at the OATS, using appropriate antennas or pyramidal horns, amplification stages, and a spectrum analyzer. Peak and average amplitudes of frequencies above 1000 MHz were compared to the required limits with worst-case data presented below. Test procedures of ANSI C63.10-2013 paragraph 6 and KDB 558074 paragraph 12 were used during testing. No other significant emission was observed which fell into the restricted bands of operation. Computed emission values consider the received radiated field strength, receive antenna correction factor, amplifier gain stage, and test system cable losses.

**Table 1 LoRa Radiated Emissions Data in Restricted Frequency Bands**

Frequency in MHz	Horizontal Peak (dBμV/m)	Horizontal Average (dBμV/m)	Vertical Peak (dBμV/m)	Vertical Average (dBμV/m)	Limit @ 3m (dBμV/m)	Horizontal Average Margin (dB)	Vertical Average Margin (dB)
<b>P-Mode</b>							
2751.9	58.6	33.7	59.3	34.5	54.0	-20.3	-19.5
2760.9	57.5	32.4	58.4	33.4	54.0	-21.6	-20.6
2770.5	57.4	32.0	57.7	32.4	54.0	-22.0	-21.6
3669.2	48.0	11.8	46.5	10.7	54.0	-42.2	-43.3
3681.2	46.7	10.8	47.4	10.8	54.0	-43.2	-43.2
3694.0	48.4	12.2	48.1	12.2	54.0	-41.8	-41.8
4586.5	48.5	12.3	48.3	11.9	54.0	-41.7	-42.1
4601.5	49.8	13.8	50.0	13.7	54.0	-40.2	-40.3
4617.5	49.5	13.2	49.9	13.2	54.0	-40.8	-40.8
<b>M-Mode</b>							
2769.6	49.5	16.5	49.9	17.0	54.0	-37.5	-37.0
3692.8	47.5	11.7	47.8	11.7	54.0	-42.3	-42.3
4616.0	49.8	13.3	50.0	13.3	54.0	-40.7	-40.7

Other emissions present had amplitudes at least 20 dB below the limit. Peak and Quasi-Peak amplitude emissions are recorded for frequency below 1000 MHz. Peak and Average amplitude emissions are recorded for frequency range above 1000 MHz.

**Summary of Results for Radiated Emissions in Restricted Bands**

The EUT demonstrated compliance with the radiated emissions requirements of 47CFR Part 15C, RSS-Gen, and RSS-247 Intentional Radiators. The EUT demonstrated a worst-case minimum radiated emission in restricted bands providing a minimum margin of -19.5 dB below the radiated emissions requirements. Peak and average amplitudes were checked for compliance with the regulations. Worst-case emissions are reported with other emissions found in the restricted frequency bands at least 20 dB below the requirements.



## ***AC Line Conducted Emissions Procedure***

The design operates solely from direct current power provided from replaceable LR6 (AA) batteries. The design offers no provision for connection with the Utility AC power system and is therefore exempt from AC Line conducted emissions testing.

## ***General Radiated Emissions Procedure***

The EUT was arranged in a typical equipment configuration and operated through all available mode during testing. Both the LoRa and BLE transmitters were operating during testing. Preliminary testing was performed in a screen room with the EUT positioned 1 meter from the FSM. Radiated emissions measurements were performed to identify the frequencies, which produced the highest emissions. Each radiated emission was then maximized at the OATS location before final radiated measurements were performed. Final data was taken with the EUT located on the OATS at 3 meters distance between the EUT and the receiving antenna. The frequency spectrum from 9 kHz to 25,000 MHz was searched for general radiated emissions. Measured emission levels were maximized by EUT placement on the table, rotating the turntable through 360 degrees, varying the antenna height between 1 and 4 meters above the ground plane and changing antenna position between horizontal and vertical polarization. Antennas used were Loop from 9 kHz to 30 MHz, Broadband Biconical from 30 to 200 MHz, Biconilog from 30 to 1000 MHz, Log Periodic from 200 MHz to 1 GHz and or double Ridge or pyramidal horns and mixers above 1 GHz, notch filters and appropriate amplifiers and external mixers were utilized.

**Table 2 General Radiated Emissions Data**

Frequency in MHz	Horizontal Peak (dB $\mu$ V/m)	Horizontal Quasi-Peak (dB $\mu$ V/m)	Vertical Peak (dB $\mu$ V/m)	Vertical Quasi-Peak (dB $\mu$ V/m)	Limit @ 3m (dB $\mu$ V/m)	Horizontal Average Margin (dB)	Vertical Average Margin (dB)
53.5	30.7	25.6	33.0	26.4	40.0	-14.4	-13.6
78.2	35.5	24.8	30.0	21.2	40.0	-15.2	-18.8
82.3	35.9	22.6	29.2	20.9	40.0	-17.4	-19.1
83.1	28.9	20.6	26.9	20.2	40.0	-19.4	-19.8
84.7	29.5	24.8	28.9	21.8	40.0	-15.2	-18.2
86.0	29.1	23.2	29.4	24.4	40.0	-16.8	-15.6
166.3	24.1	15.3	18.3	12.5	40.0	-24.7	-27.5

Other emissions present had amplitudes at least 20 dB below the limit. Peak and Quasi-Peak amplitude emissions are recorded for frequency range below 1000 MHz. Peak and Average amplitude emissions are recorded for frequency range above 1000 MHz.

**Summary of Results for General Radiated Emissions**

The EUT demonstrated compliance with the radiated emissions requirements of 47CFR Part 15C paragraph 15.209, RSS-247 and RSS-GEN Intentional Radiators. The EUT demonstrated a minimum margin of -13.6 dB below the requirements. Other emissions were present with amplitudes at least 20 dB below the Limits.

## **Operation in the Band 902-928 MHz (LoRa)**

The requirements and demonstration of compliance with RSS-247 and 47CFR subpart 15.247 are addressed below and as specified in KDB 558074 D01 15.247 Meas Guidance v05r02. The LoRa transmitter provides operation as Hybrid and Digital Transmission System. Test sample #1 was used during radiated emissions measurements. Both the LoRa and BLE transmitters were operating during testing. Test sample #2 was provided for testing antenna port conducted emissions. Test sample #2 was modified by replacing the internal antenna with a 50-ohm antenna port connector and attenuator for testing purposes. Test procedures of ANSI C63.10-2013 paragraph 6, and KDB 558074 v05r02 were used during transmitter testing.

Information from KDB 558074 D01 15.247 Meas Guidance v05r02

### **10. HYBRID SYSTEM EQUIPMENT UNDER SECTION 15.247**

The following information is for certification of hybrid spread-spectrum devices under Section 15.247.

a) Use Form-731 equipment-class code DSS.

b) Hybrid system device measurement guidelines are as follows.

- 1) As specified in Section 15.247(f), a hybrid system must comply with the power density standard of 8 dBm in any 3 kHz band when the frequency hopping function is turned off.
- 2) The transmission must comply with a 0.4 second/channel maximum dwell time when the hopping function is turned on.
- 3) There is no requirement for this type of hybrid system to comply with the 500 kHz minimum bandwidth normally associated with a DTS device.
- 4) There is no minimum number of hopping channels associated with this type of hybrid system. While there is not a specific minimum limit, the hop sequence is required to appear as pseudorandom per Section 15.247(a)(1) (see Section 3 of this document).
- 5) The hopping function must be a true frequency hopping system, as described in Section 15.247(a)(1). The specific requirements in Section 15.247(a)(1) are:
  - i) a minimum channel separation;
  - ii) pseudo-random hop sequence;
  - iii) equal use of each frequency; and
  - iv) receiver matching bandwidth and synchronization.
- 6) Generally, use the test procedures for DTS and FHSS devices in Clause 11 and 7.8 of ANSI C63.10, respectively.
  - i) Output power: use 11.9 of ANSI C63.10;
  - ii) Peak Power Density: use 11.10 of ANSI C63.10;
  - iii) Carrier channel separation: use 7.8.2 of ANSI C63.10;
  - iv) Dwell time: use 7.8.4 of ANSI C63.10.

The design operates as P-mode equipment for communications during typical operation and pairing with remote base station.

Example of P-mode operation after initial pairing of sensor with base, the base continuously listens to both frequencies.

- Upon the sensor awakening, the wake-up counter is started.
- The sensor generates random number between 0.4 and 3.5. This variable is referenced as “T”
- Assuming the sensor operating in this channel group (for this example) is allowed to transmit data at either 917.3MHz or 922.9MHz
- Before each data transmission, the sensor will pseudo randomly chose frequency in which to transmit data - 917.3MHz or 922.9MHz
- Assuming that this time the pseudo random generation has chosen 917.3 MHz frequency in which to transmit data
- The sensor then “listens” to frequency 917.3MHz, to determine if the frequency is open or occupied.
- If frequency 917.3MHz is open, the sensor will send data to base. If frequency is occupied, it will wait for “T” seconds and “listen” again. “Listening” can happen only 2 times. If both times frequency 917.3MHz is occupied, on 3<sup>rd</sup> time the sensor will transmit data at 917.3MHz.
- Length of data transmission from sensor to base is 250ms and can only happen once every minute at highest data rate and once every 10 minutes for longest battery life.
- After data is transmitted, sensor goes to “sleep” and wakes up only when wake-up counter hits 600s + “T” seconds spent on listening if frequency 917.3MHz was occupied.
- When counter is done, sensor will wake-up and pseudo randomly chose frequency in which to transmit data - 917.3MHz or @ 922.9MHz and begin the cycle again.

Modulation information:

Modulation parameters during sensor pairing mode (18229.17 bits per second; 0.26ms symbol time). Modulation parameters during regular operation (813.8 bits per second; 8.19ms symbol time)

Compliance for operation as Digital Modulation System addresses the 6-dB DTS bandwidth, output power, power spectral density, and emissions in 100 kHz bands. LoRa (M-Node) 902-928 MHz plots demonstrating compliance with DTS requirements are presented in figures one through eight.

Compliance for Hybrid operation addresses 0.4 second/channel maximum dwell time, minimum channel separation, Pseudo-random hop sequence, equal use of frequency, receiver bandwidth

matching and synchronization. LoRa (P-Node) 902-928 MHz plots demonstrating compliance with these requirements are presented in figures nine through twenty.

The amplitude of each harmonic and general radiated emission was measured on the OATS at distance of 3 meters from the FSM antenna (testing was performed on samples 1 representative of production equipment with integral antenna). The EUT was positioned on supporting turntable elevated as required above the ground plane, at a distance of 3 meters from the FSM antenna. Radiated emission investigations were performed from 9 kHz to 10,000 MHz. Each radiated emission was maximized by varying the FSM antenna height and polarization, and by rotating the turntable. The worst-case amplitude of each emission was then recorded from the analyzer display. The peak and quasi-peak amplitude of frequencies below 1000 MHz were measured using a spectrum analyzer. The peak and average amplitude of frequencies above 1000 MHz were measured using a spectrum analyzer. A Loop antenna was used for measuring emissions from 0.009 to 30 MHz, Biconilog Antenna for 30 to 1000 MHz, Double-Ridge, and/or Pyramidal Horn Antennas above 1 GHz.

Figure 1 LoRa (M-Mode) Plot of Transmitter Emissions in Operational Frequency Band

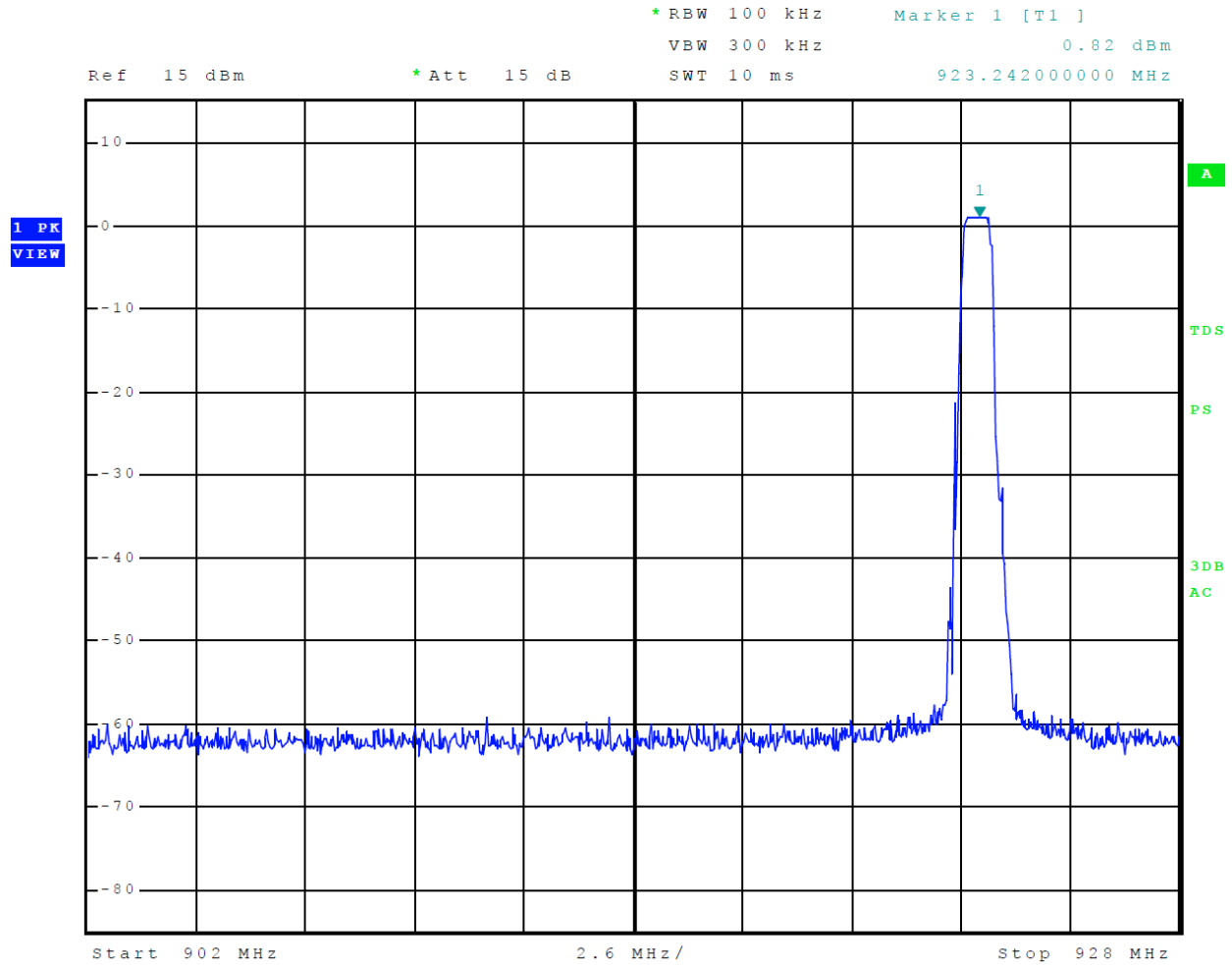

Figure 2 LoRa (M-Mode) Plot of Lower Band Edge

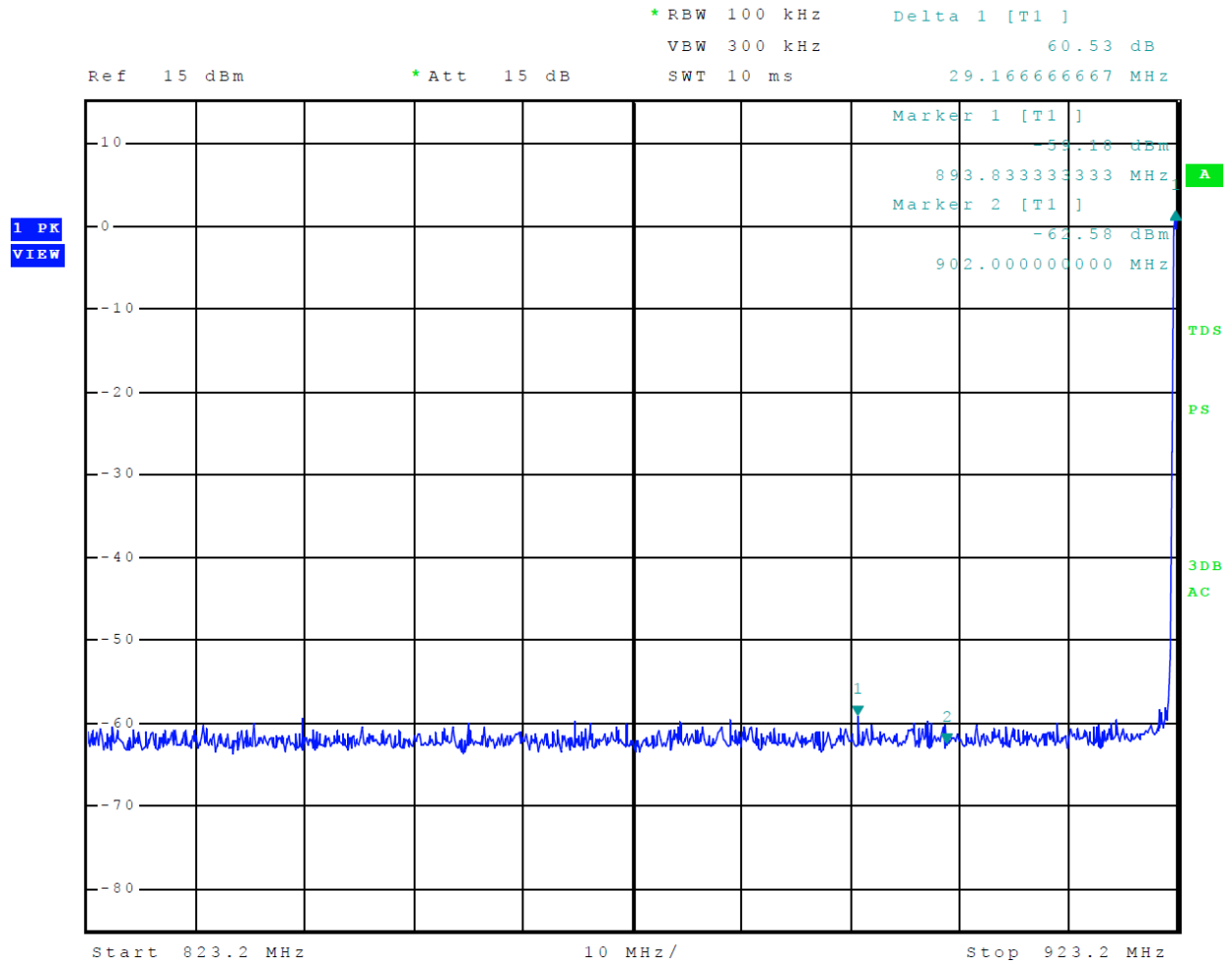

Figure 3 LoRa (M-Mode) Plot of Upper Band Edge

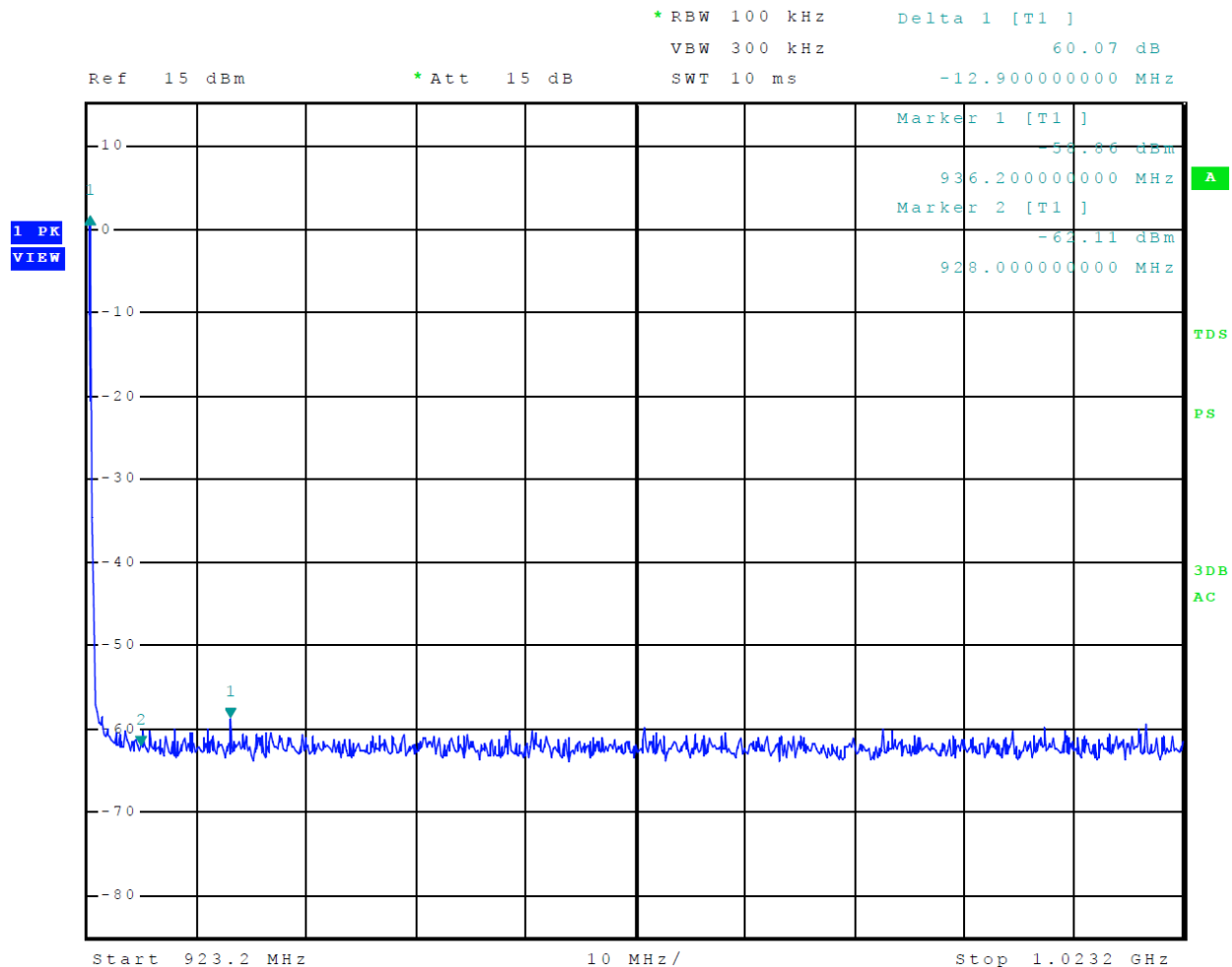



Figure 4 LoRa (M-Mode) Plot of Transmitter 6-dB Occupied Bandwidth

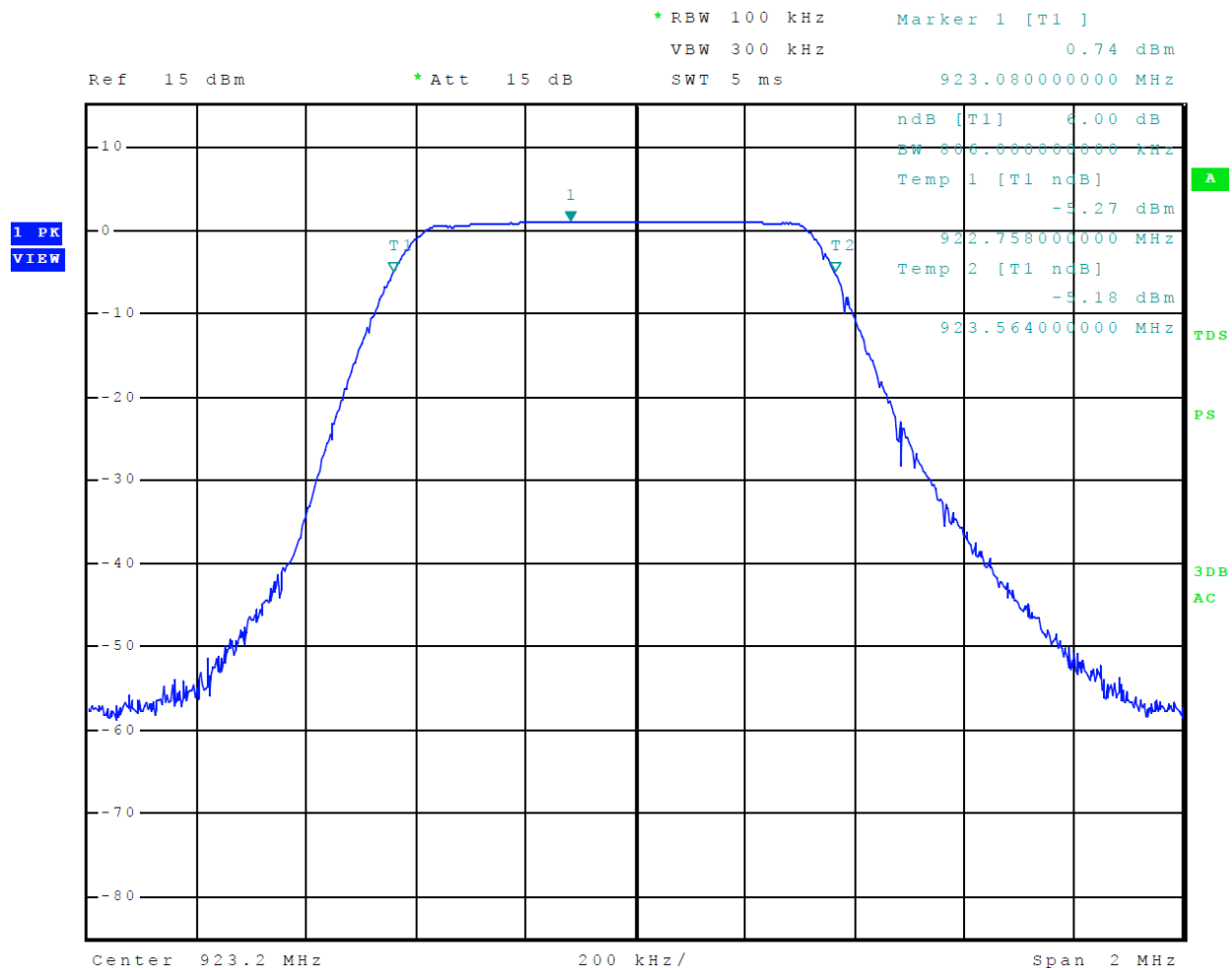

Figure 5 LoRa (M-Mode) Plot of Transmitter 99% Occupied Bandwidth

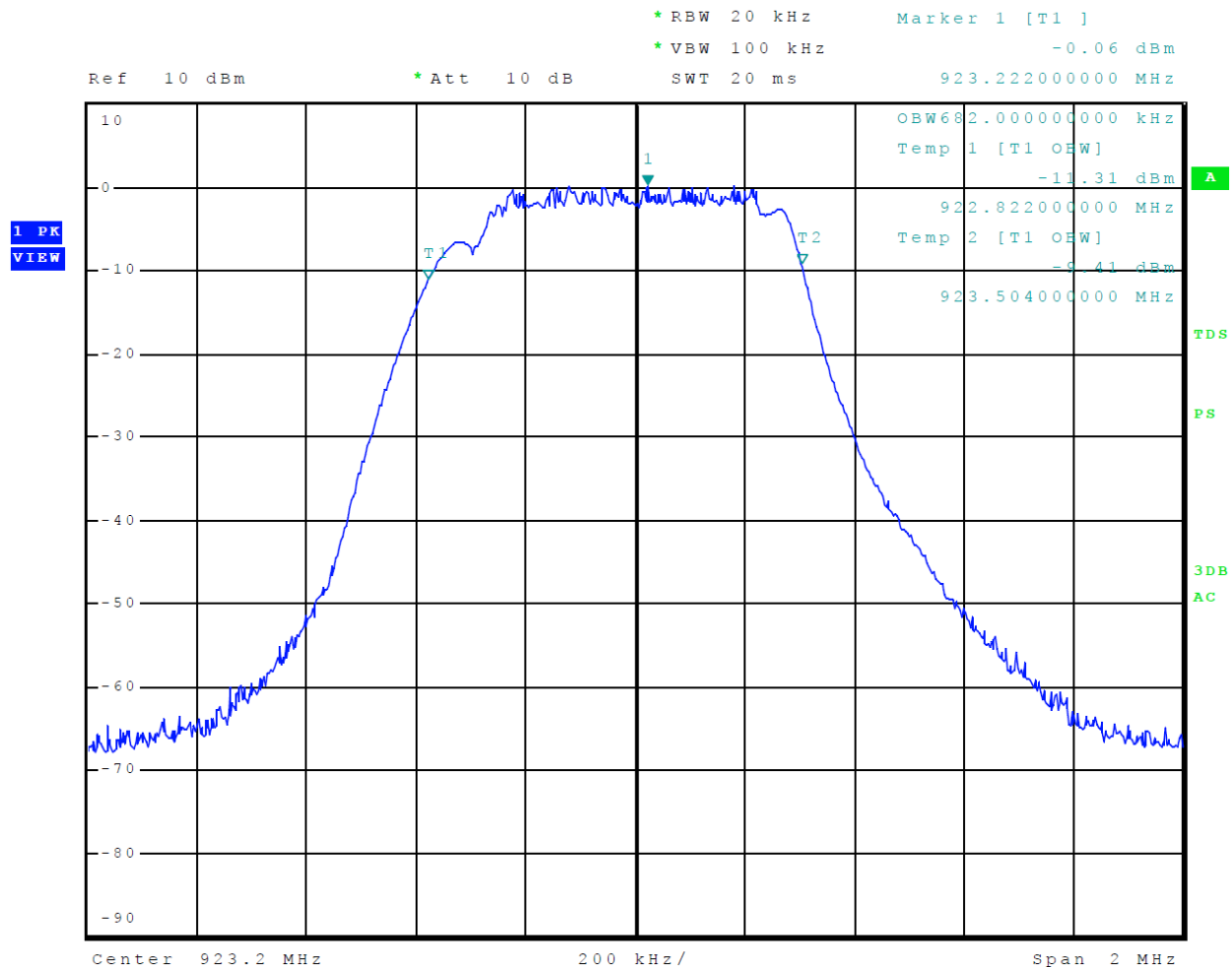

Figure 6 LoRa (M-Mode) Plot of Power Spectral Density

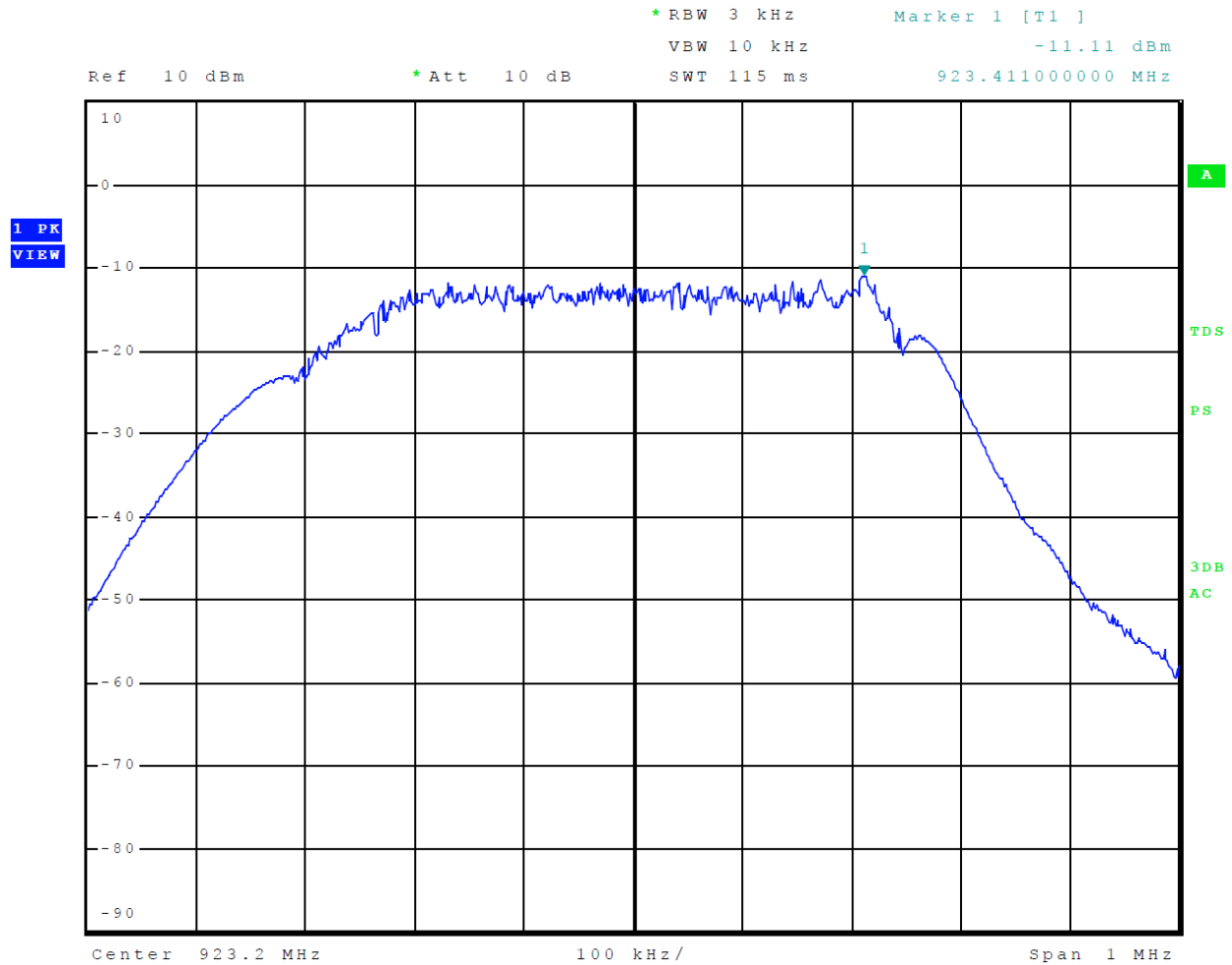

Figure 7 LoRa (M-Mode) Plot of Output Power

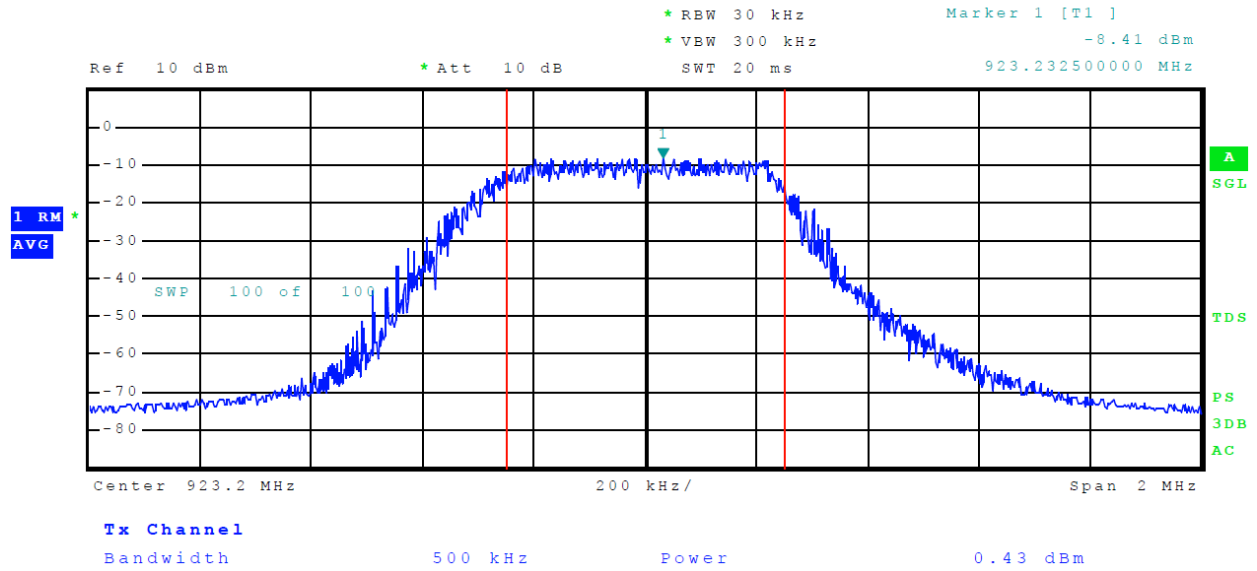

Figure 8 LoRa (M-Mode) Plot of Out of Band Emissions

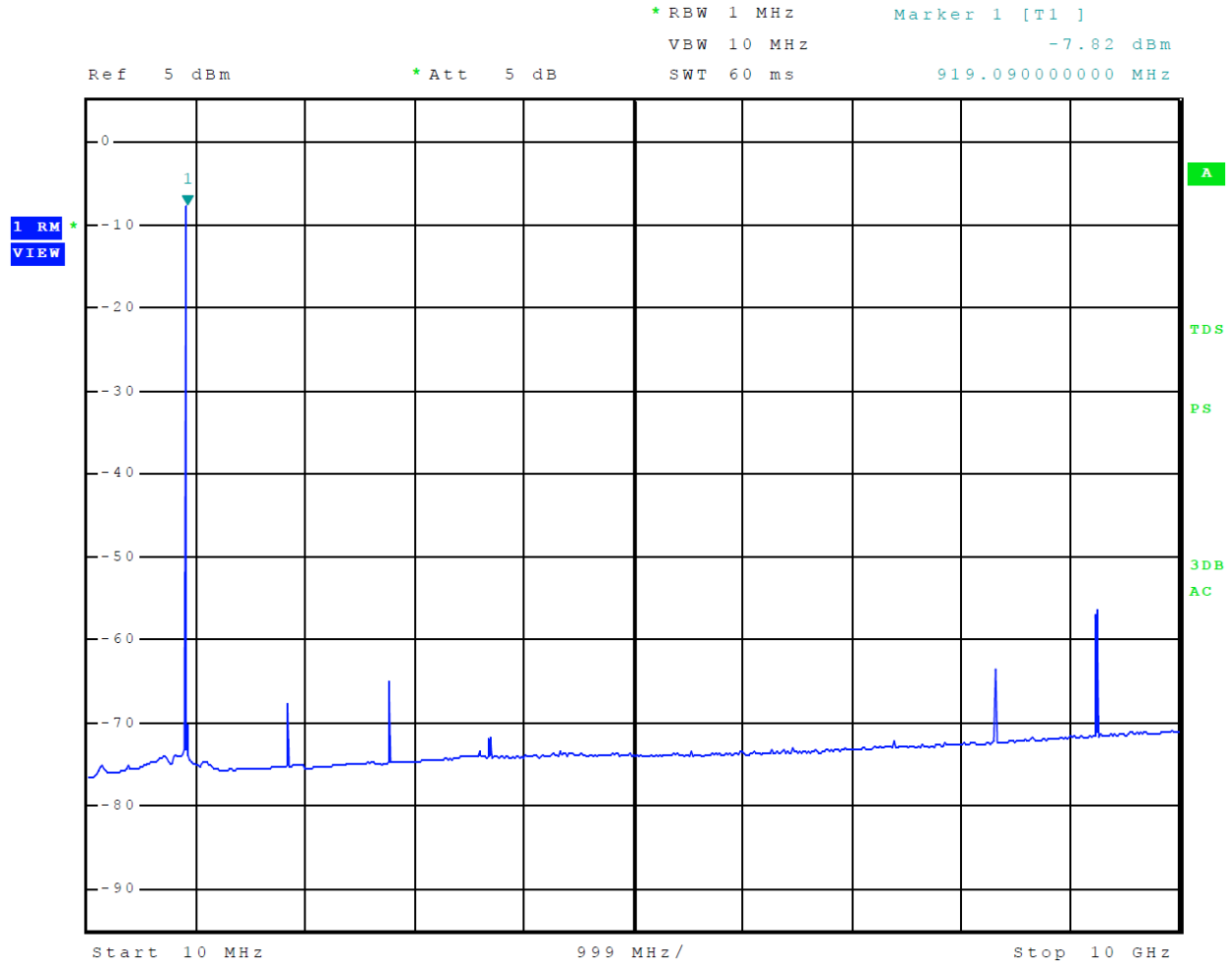

Figure 9 LoRa (P-Mode) Plot of Transmitter Emissions in Operational Frequency Band

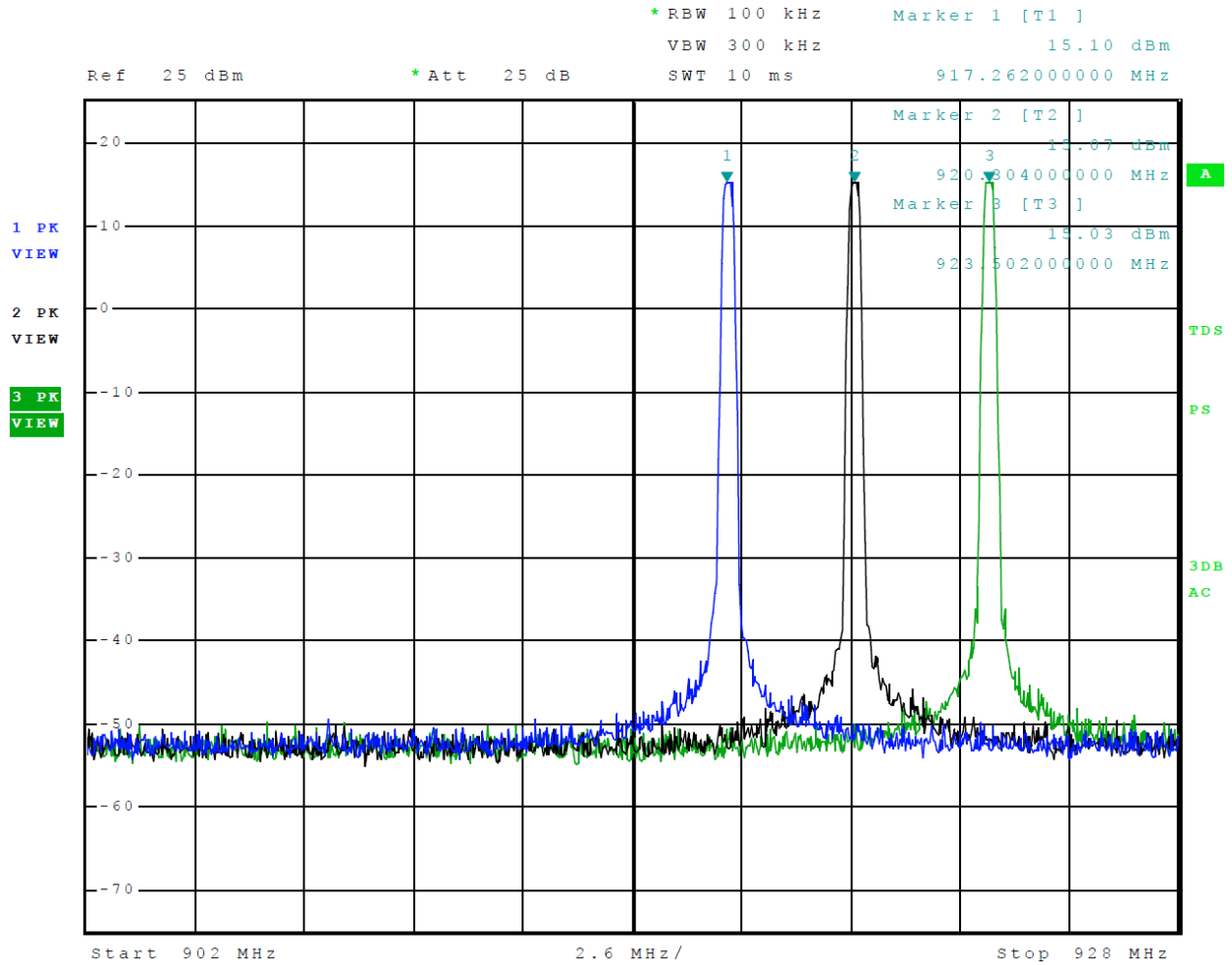

Figure 10 LoRa (P-Mode) Plot of Lower Band Edge

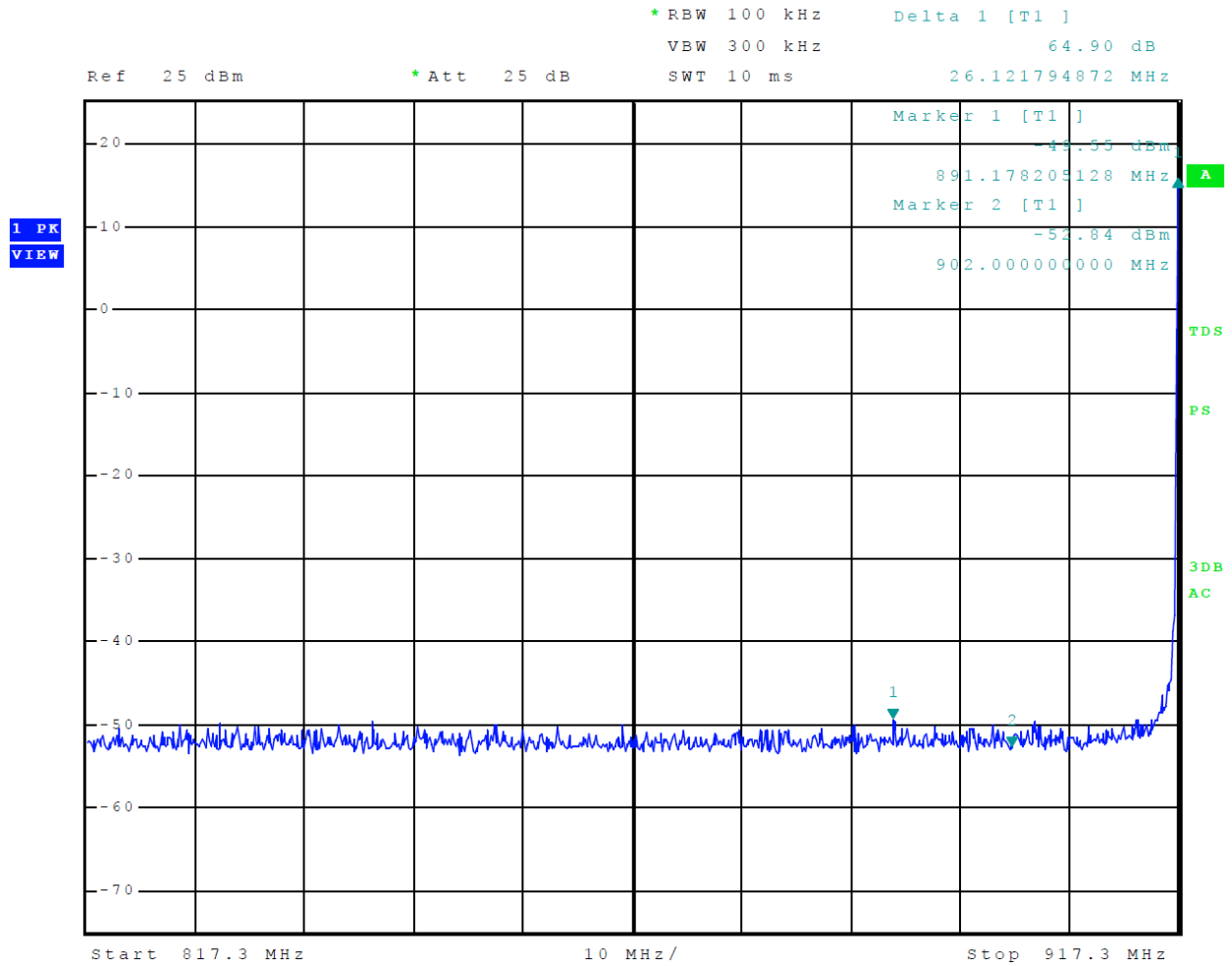

Figure 11 LoRa (P-Mode) Plot of Upper Band Edge

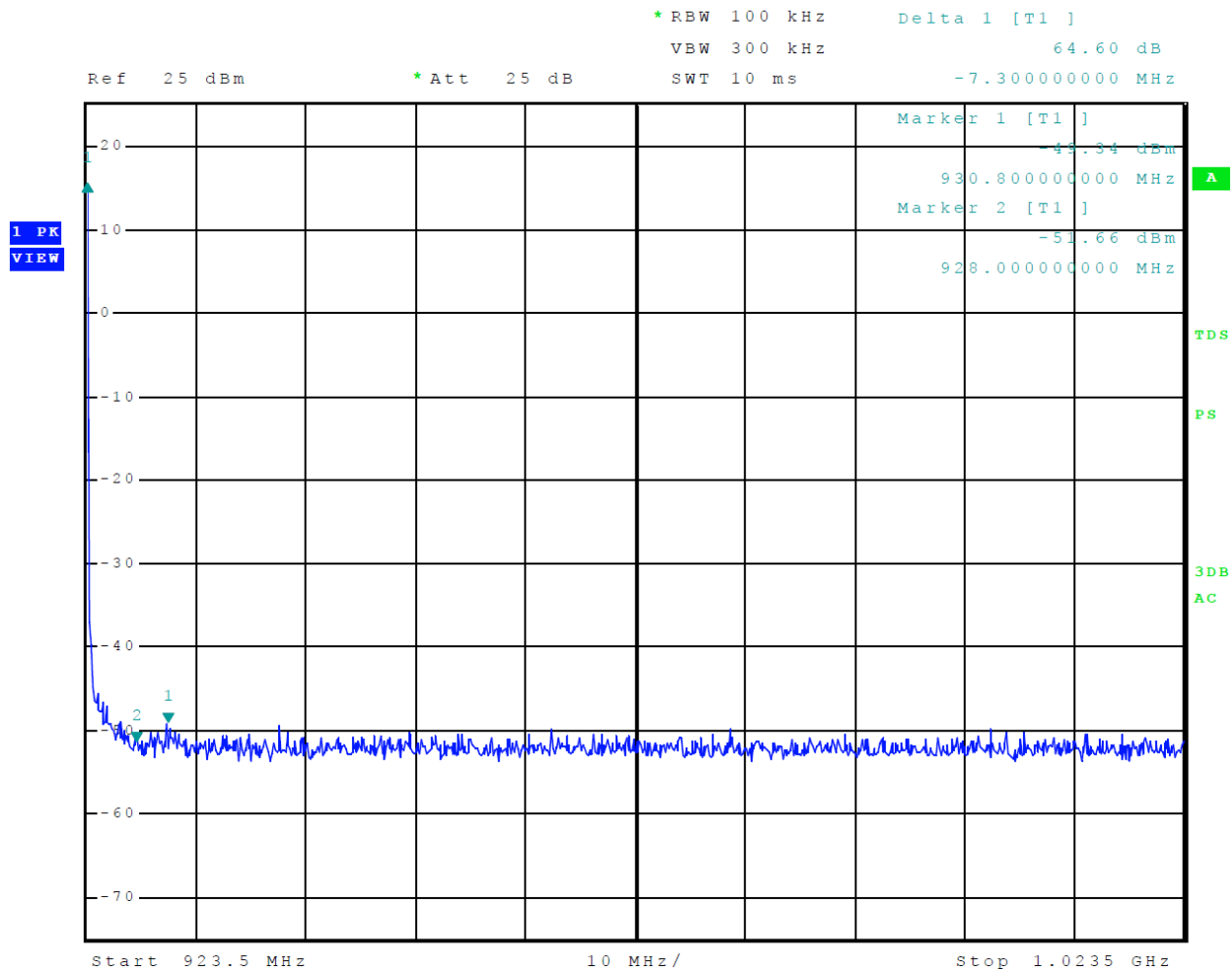



Figure 12 LoRa (P-Mode) Plot of Transmitter 20-dB Occupied Bandwidth

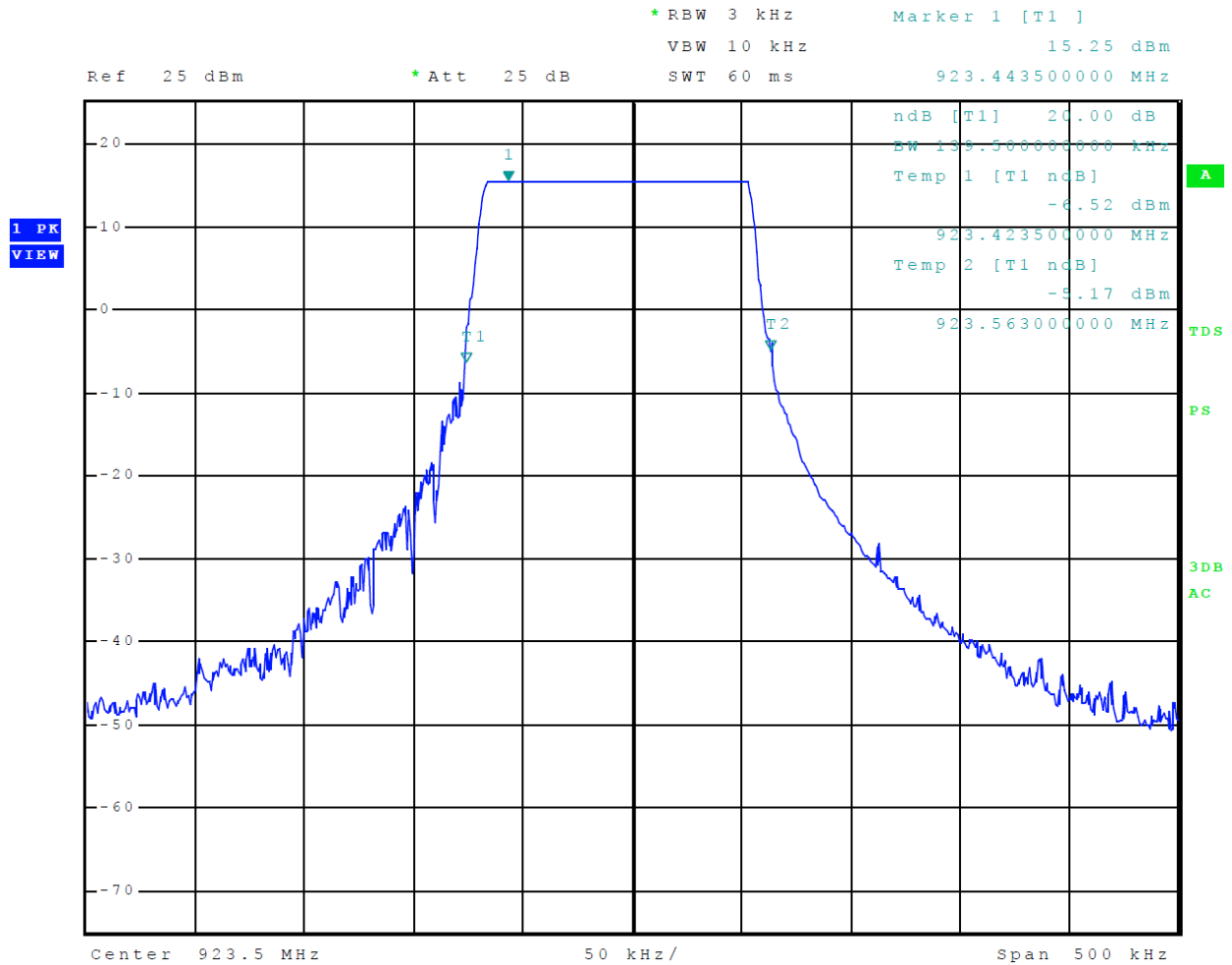

Figure 13 LoRa (P-Mode) Plot of Transmitter 99% Occupied Bandwidth

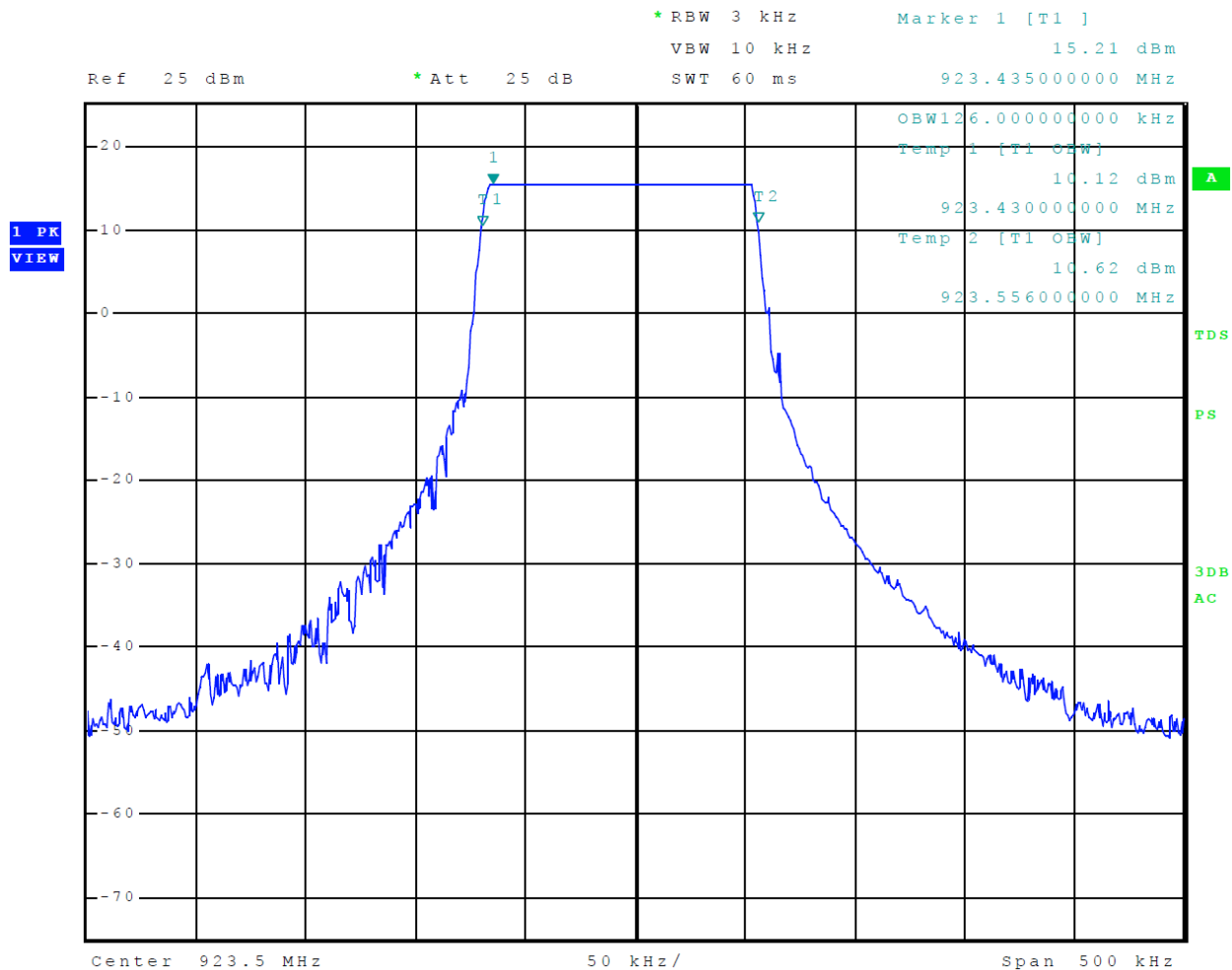

Figure 14 LoRa (P-Mode) Plots of Power Spectral Density

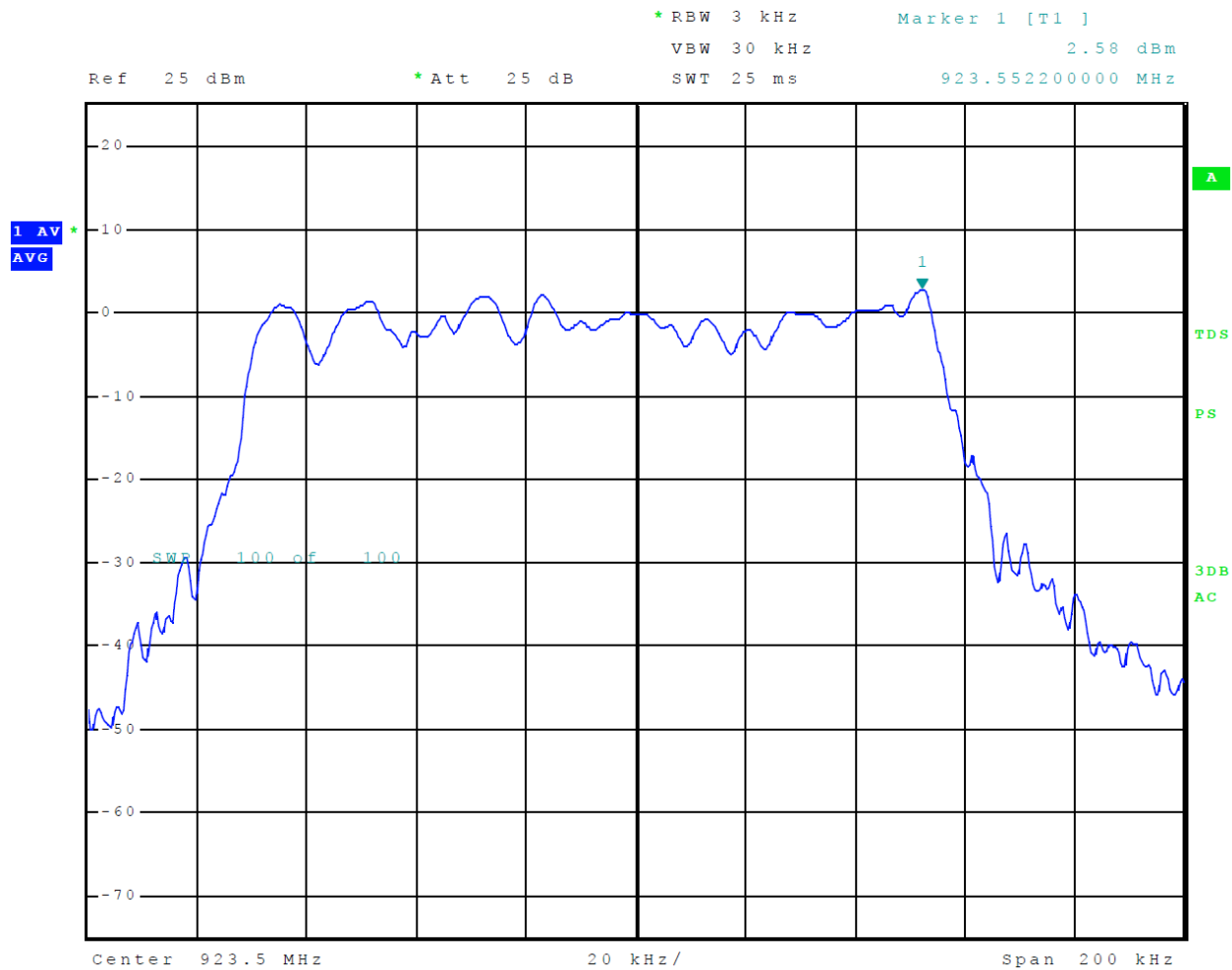
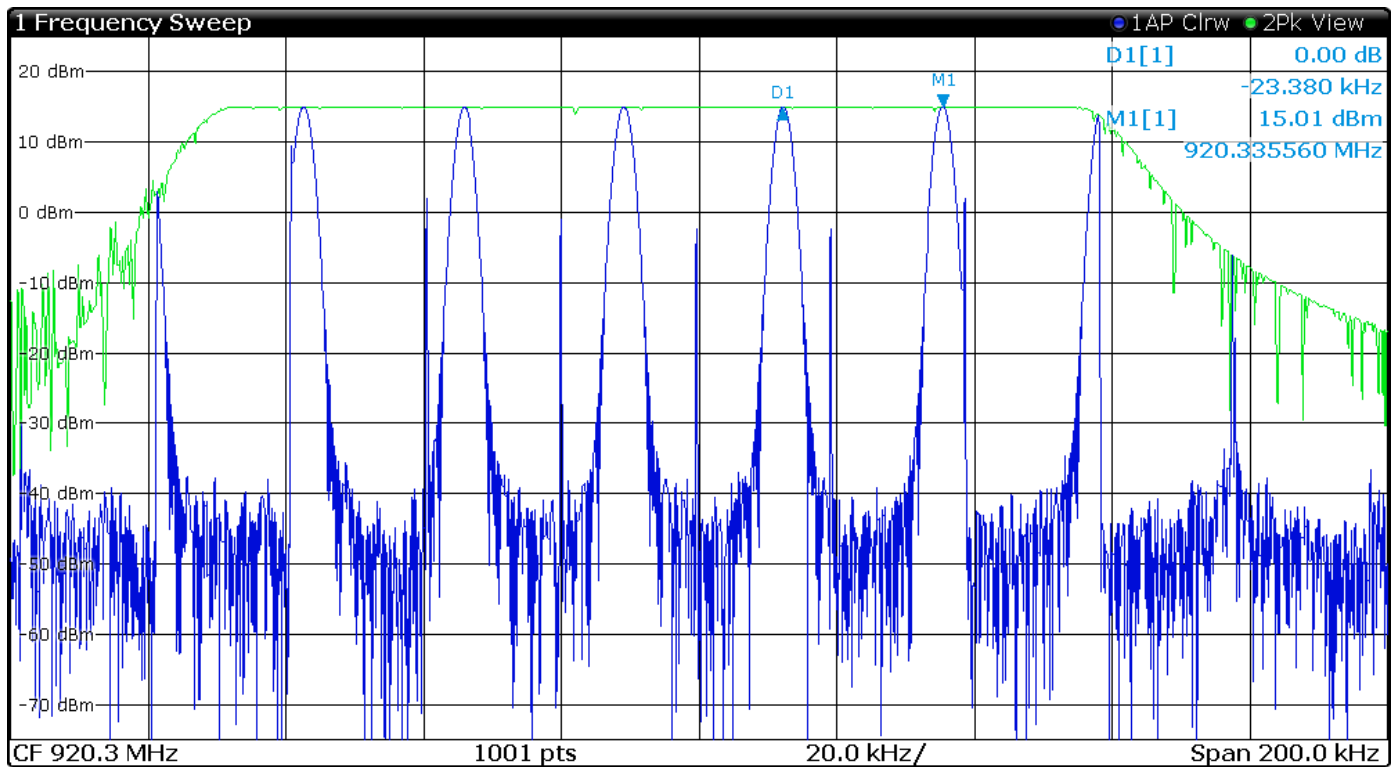

Figure 15 LoRa (P-Mode) Plot of Channel Separation



Center Freq: 920.3 MHz	Freq Offset: 0 Hz	Start: 920.2 MHz	Stop: 920.4 MHz
Span: 200 kHz	RBW: 10 kHz	Filter Type: Normal(3dB)	VBW: 30 kHz
SWT: 83.7 ms	Ref Level: 25 dBm	Level Offset: 0 dB	Rf Att: 25 dB
Input: 1 AC	Preamplifier: OFF	Preselector: Off	

Figure 16 LoRa (P-Mode) Plot of Dwell Time on channel

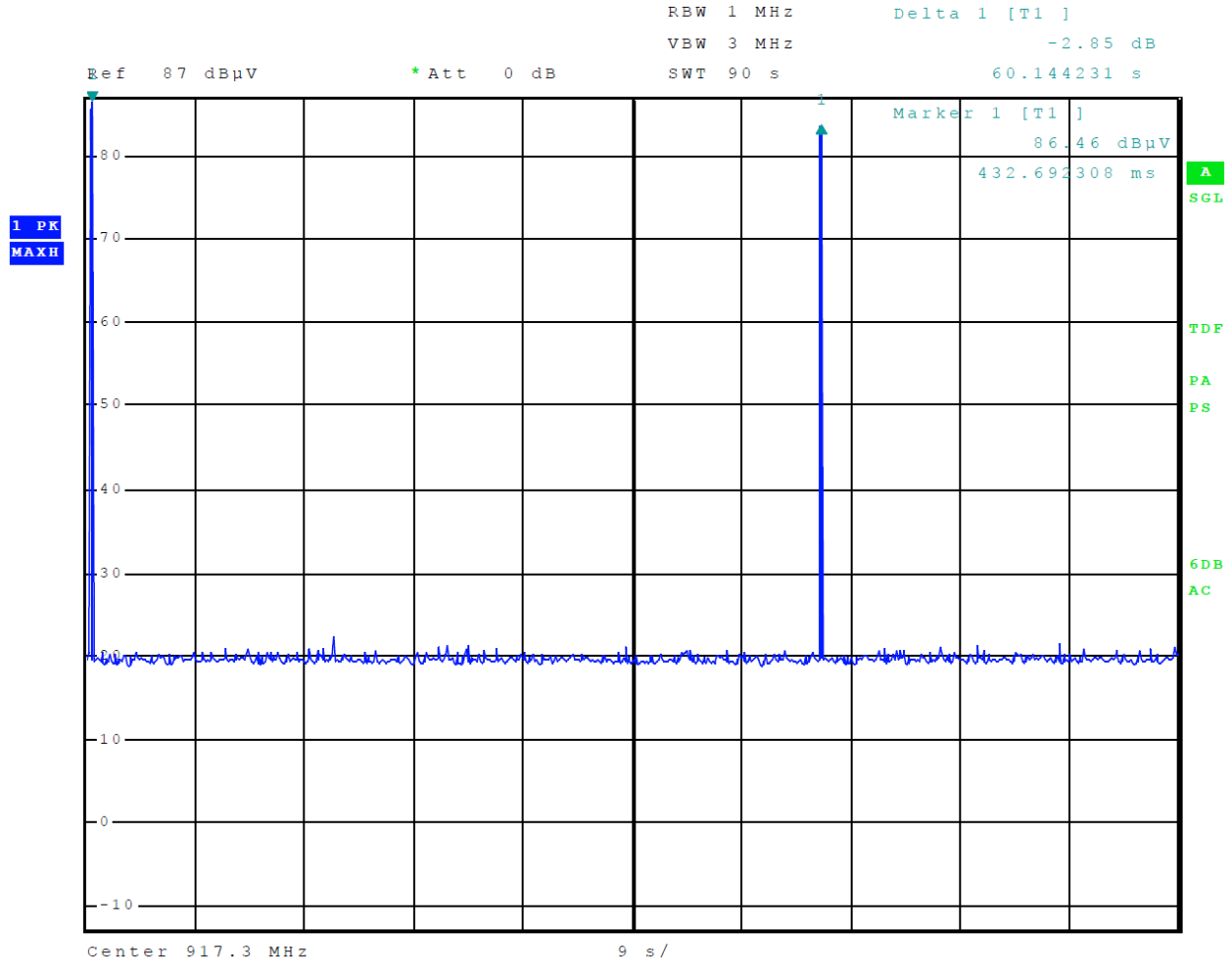

Figure 17 LoRa (P-Mode) Plot of Output Power

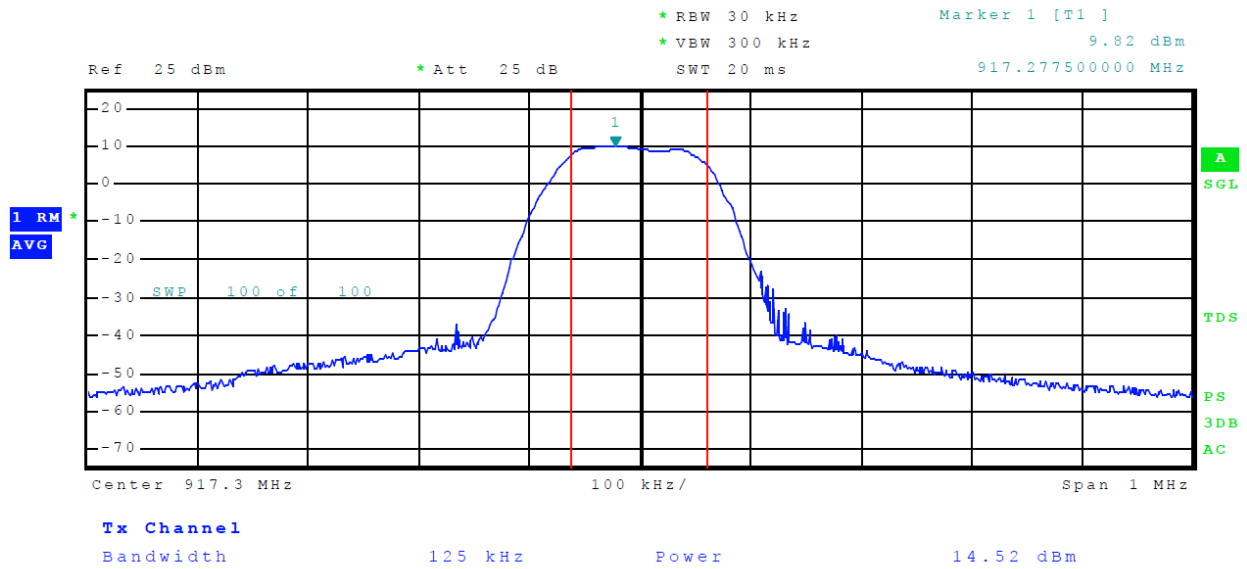

Figure 18 LoRa (P-Mode) Plot of Output Power

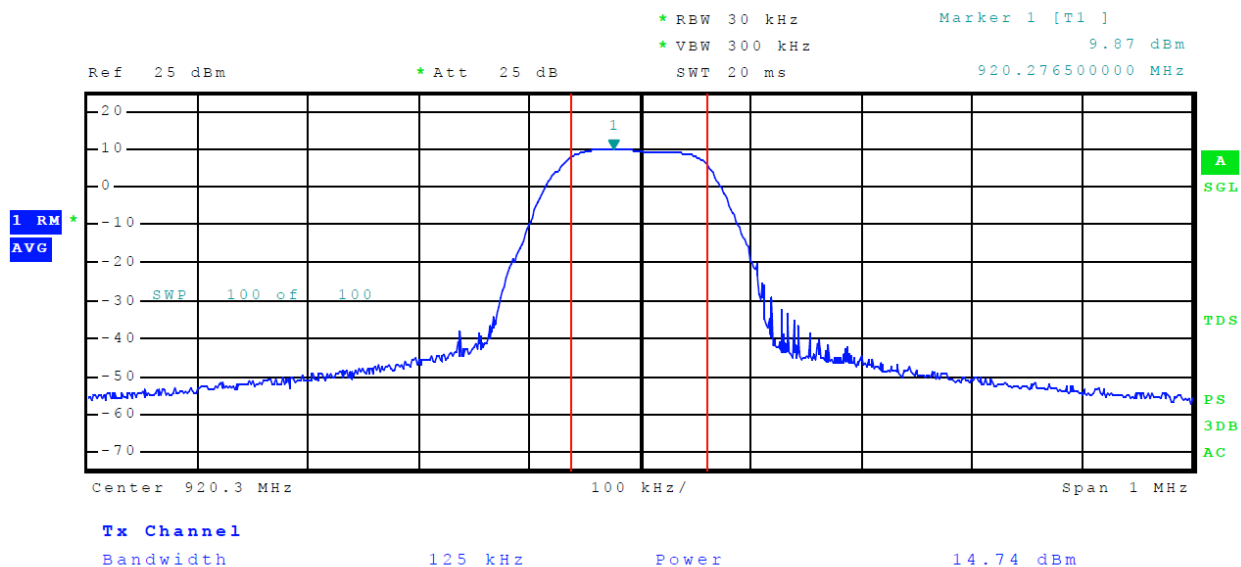

Figure 19 LoRa (P-Mode) Plot of Output Power

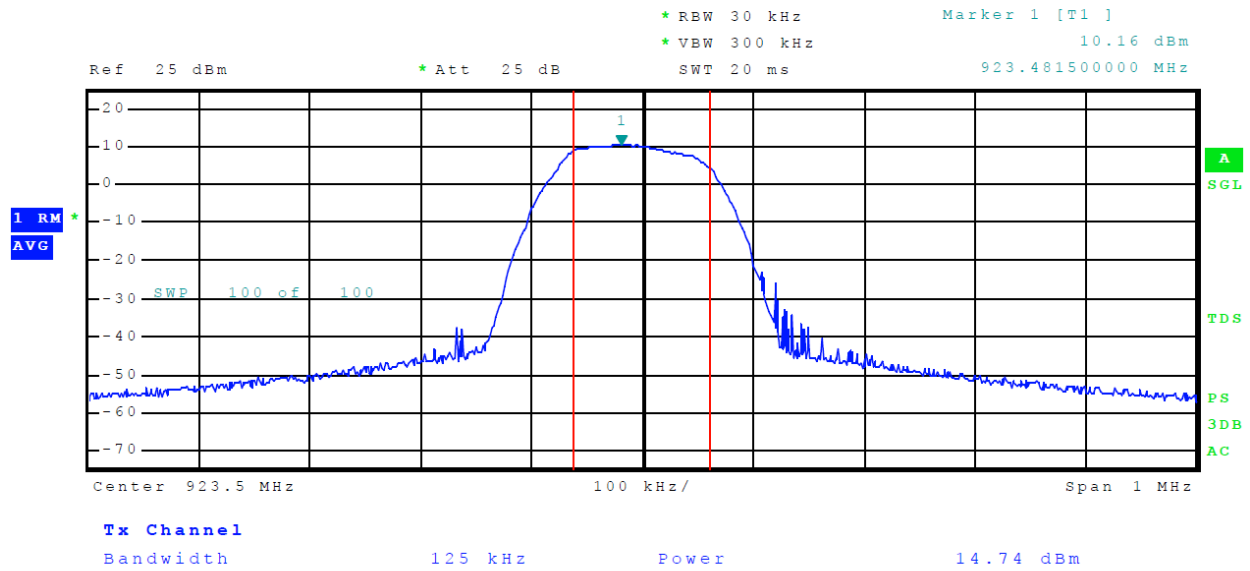
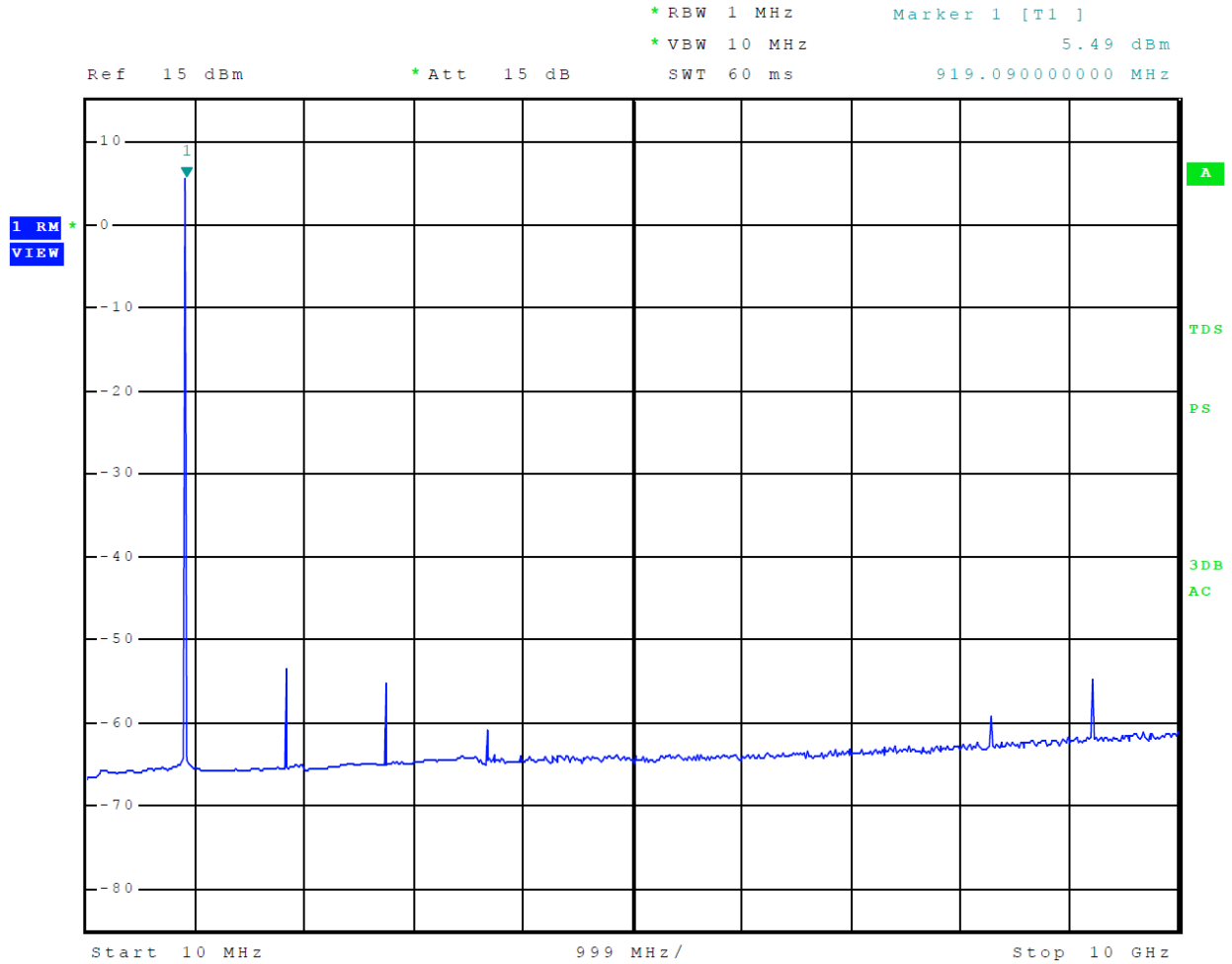



Figure 20 LoRa (P-Mode) Plot of Out of Band Emissions



### Transmitter Emissions Data

**Table 3 LoRa Transmitter Radiated Emission Worst-case Data**

Frequency in MHz	Horizontal Peak (dBµV/m)	Horizontal Average (dBµV/m)	Vertical Peak (dBµV/m)	Vertical Average (dBµV/m)	Limit @ 3m (dBµV/m)	Horizontal Average Margin (dB)	Vertical Average Margin (dB)
917.3	--	--	--	--	--	--	--
1834.6	50.3	23.5	51.1	24.4	54.0	-30.5	-29.6
2751.9	58.6	33.7	59.3	34.5	54.0	-20.3	-19.5
3669.2	48.0	11.8	46.5	10.7	54.0	-42.2	-43.3
4586.5	48.5	12.3	48.3	11.9	54.0	-41.7	-42.1
5503.8	50.1	8.3	50.9	15.2	54.0	-45.7	-38.8
6421.1	53.2	17.1	55.3	22.3	54.0	-36.9	-31.7
920.3	--	--	--	--	--	--	--
1840.6	51.9	21.6	50.2	23.6	54.0	-32.4	-30.4
2760.9	57.5	32.4	58.4	33.4	54.0	-21.6	-20.6
3681.2	46.7	10.8	47.4	10.8	54.0	-43.2	-43.2
4601.5	49.8	13.8	50.0	13.7	54.0	-40.2	-40.3
5521.8	51.1	14.5	51.2	15.3	54.0	-39.5	-38.7
6442.1	53.5	17.5	55.1	22.3	54.0	-36.5	-31.7
923.5	--	--	--	--	--	--	--
1847.0	50.3	23.5	51.4	25.0	54.0	-30.5	-29.0
2770.5	57.4	32.0	57.7	32.4	54.0	-22.0	-21.6
3694.0	48.4	12.2	48.1	12.2	54.0	-41.8	-41.8
4617.5	49.5	13.2	49.9	13.2	54.0	-40.8	-40.8
5541.0	51.8	15.4	52.0	15.8	54.0	-38.6	-38.2
6464.5	53.0	17.2	55.1	20.8	54.0	-36.8	-33.2

Other emissions present had amplitudes at least 20 dB below the limit. Peak and Quasi-Peak amplitude emissions are recorded for frequency below 1000 MHz. Peak and Average amplitude emissions are recorded for frequency range above 1000 MHz.

**Table 4 Transmitter Antenna Port Data**

Frequency MHz	Antenna Port Output Power (Watts)	99% Occupied Bandwidth (kHz)	20-dB Occupied Bandwidth (kHz)	6-dB Occupied Bandwidth (kHz)	Peak Power Spectral Density (dBm/3kHz)
P-mode					
917.3	0.028	125.5	138.0	N/A	1.4
920.3	0.030	125.5	138.0	N/A	2.4
923.5	0.030	126.0	139.5	N/A	2.6
M-mode					
923.2	0.001	682.0	N/A	806.0	-11.11

**Summary of Results for Transmitter Radiated Emissions of Intentional Radiator**

The EUT demonstrated compliance with the radiated emissions requirements of 47CFR Part 15.247, RSS-GEN, and RSS-247 Hybrid Digital Transmission System. The LoRa (902-928 MHz) average antenna port conducted output power measured was 0.030 Watts. The LoRa power spectral density measured at the antenna port presented a minimum margin of -5.4 dB below the requirements. The LoRa transmitter demonstrated a minimum margin of -19.5 dB below the harmonic emissions requirements.

There were no other significantly measurable emissions in the restricted bands other than those recorded in this report. Other emissions were present with amplitudes at least 20 dB below the requirements. There were no other deviations or exceptions to the requirements.

## Annex

- Annex A Measurement Uncertainty Calculations
- Annex B Additional Test Equipment
- Annex C Rogers Qualifications
- Annex D Laboratory Certificate of Accreditation

## Annex A Measurement Uncertainty Calculations

The measurement uncertainty was calculated for all measurements listed in this test report according To CISPR 16-4. Result of measurement uncertainty calculations are recorded below. Component and process variability of production devices similar to those tested may result in additional deviations. The manufacturer has the sole responsibility of continued compliance.

Measurement	Expanded Measurement Uncertainty $U_{(lab)}$
3 Meter Horizontal 0.009-1000 MHz Measurements	4.16
3 Meter Vertical 0.009-1000 MHz Measurements	4.33
3 Meter Measurements 1-18 GHz	5.14
3 Meter Measurements 18-40 GHz	5.16
10 Meter Horizontal Measurements 0.009-1000 MHz	4.15
10 Meter Vertical Measurements 0.009-1000 MHz	4.32
AC Line Conducted	1.75
Antenna Port Conducted power	1.17
Frequency Stability	1.00E-11
Temperature	1.6°C
Humidity	3%

## Annex B Test Equipment

<u>Equipment</u>	<u>Manufacturer</u>	<u>Model (SN)</u>	<u>Band</u>	<u>Cal Date(m/d/y)</u>	<u>Due</u>
<input type="checkbox"/> LISN	FCC	FCC-LISN-50-25-10(1PA) (160611)	.15-30MHz	4/6/2021	4/6/2022
<input type="checkbox"/> LISN	Compliance Design	FCC-LISN-2.Mod.cd,(126)	.15-30MHz	10/14/2021	10/14/2022
<input checked="" type="checkbox"/> Cable	Huber & Suhner Inc.	Sucoflex102ea(L10M)(303073)	9kHz-40 GHz	10/14/2021	10/14/2022
<input type="checkbox"/> Cable	Huber & Suhner Inc.	Sucoflex102ea(1.5M)(303069)	9kHz-40 GHz	10/14/2021	10/14/2022
<input checked="" type="checkbox"/> Cable	Huber & Suhner Inc.	Sucoflex102ea(1.5M)(303070)	9kHz-40 GHz	10/14/2021	10/14/2022
<input type="checkbox"/> Cable	Belden	RG-58 (L1-CAT3-11509)	9kHz-30 MHz	10/14/2021	10/14/2022
<input type="checkbox"/> Cable	Belden	RG-58 (L2-CAT3-11509)	9kHz-30 MHz	10/14/2021	10/14/2022
<input checked="" type="checkbox"/> Antenna	Com Power	AL-130 (121055)	.001-30 MHz	10/14/2021	10/14/2022
<input type="checkbox"/> Antenna:	EMCO	6509	.001-30 MHz	10/14/2020	10/14/2022
<input type="checkbox"/> Antenna	ARA	BCD-235-B (169)	20-350MHz	10/14/2021	10/14/2022
<input type="checkbox"/> Antenna:	Schwarzbeck Model	VHBB 9124 (1468)		10/14/2020	10/14/2022
<input checked="" type="checkbox"/> Antenna	Sunol	JB-6 (A100709)	30-1000 MHz	10/14/2021	10/14/2022
<input type="checkbox"/> Antenna	ETS-Lindgren	3147 (40582)	200-1000MHz	10/14/2020	10/14/2022
<input type="checkbox"/> Antenna:	Schwarzbeck Model:	VULP 9118 A (VULP 9118 A-534)		10/14/2020	10/14/2022
<input checked="" type="checkbox"/> Antenna	ETS-Lindgren	3117 (200389)	1-18 GHz	4/21/2020	4/21/2022
<input type="checkbox"/> Antenna	Com Power	AH-118 (10110)	1-18 GHz	10/14/2020	10/14/2022
<input checked="" type="checkbox"/> Antenna	Com Power	AH-840 (101046)	18-40 GHz	4/6/2021	4/6/2023
<input checked="" type="checkbox"/> Analyzer	Rohde & Schwarz	ESU40 (100108)	20Hz-40GHz	5/20/2021	5/20/2022
<input checked="" type="checkbox"/> Analyzer	Rohde & Schwarz	ESW44 (101534)	20Hz-44GHz	1/12/2021	1/12/2022
<input type="checkbox"/> Analyzer	Rohde & Schwarz	FS-Z60, 90, 140, and 220	40GHz-220GHz	12/22/2017	12/22/2027
<input checked="" type="checkbox"/> Amplifier	Com-Power	PA-010 (171003)	100Hz-30MHz	10/14/2021	10/14/2022
<input checked="" type="checkbox"/> Amplifier	Com-Power	CPPA-102 (01254)	1-1000 MHz	10/14/2021	10/14/2022
<input checked="" type="checkbox"/> Amplifier	Com-Power	PAM-118A (551014)	0.5-18 GHz	10/14/2021	10/14/2022
<input checked="" type="checkbox"/> Amplifier	Com-Power	PAM-840A (461328)	18-40 GHz	10/14/2021	10/14/2022
<input type="checkbox"/> Power Meter	Agilent	N1911A with N1921A	0.05-40 GHz	4/6/2021	4/6/2022
<input type="checkbox"/> Generator	Rohde & Schwarz	SMB100A6 (100150)	20Hz-6 GHz	4/6/2021	4/6/2022
<input type="checkbox"/> Generator	Rohde & Schwarz	SMBV100A6 (260771)	20Hz-6 GHz	4/6/2021	4/6/2022
<input type="checkbox"/> RF Filter	Micro-Tronics	BRC50722 (009).9G notch	30-18000 MHz	4/6/2021	4/6/2022
<input type="checkbox"/> RF Filter	Micro-Tronics	HPM50114 (017)1.5G HPF	30-18000 MHz	4/6/2021	4/6/2022
<input type="checkbox"/> RF Filter	Micro-Tronics	HPM50117 (063) 3G HPF	30-18000 MHz	4/6/2021	4/6/2022
<input type="checkbox"/> RF Filter	Micro-Tronics	HPM50105 (059) 6G HPF	30-18000 MHz	4/6/2021	4/6/2022
<input type="checkbox"/> RF Filter	Micro-Tronics	BRM50702 (172) 2G notch	30-18000 MHz	4/6/2021	4/6/2022
<input type="checkbox"/> RF Filter	Micro-Tronics	BRC50703 (G102) 5G notch	30-18000 MHz	4/6/2021	4/6/2022
<input type="checkbox"/> RF Filter	Micro-Tronics	BRC50705 (024) 5G notch	30-18000 MHz	4/6/2021	4/6/2022
<input type="checkbox"/> Attenuator	Fairview	SA6NFN100W-40 (1625)	30-18000 MHz	4/6/2021	4/6/2022
<input type="checkbox"/> Attenuator	Mini-Circuits	VAT-3W2+ (1436)	30-6000 MHz	4/6/2021	4/6/2022
<input type="checkbox"/> Attenuator	Mini-Circuits	VAT-3W2+ (1445)	30-6000 MHz	4/6/2021	4/6/2022
<input type="checkbox"/> Attenuator	Mini-Circuits	VAT-3W2+ (1735)	30-6000 MHz	4/6/2021	4/6/2022
<input type="checkbox"/> Attenuator	Mini-Circuits	VAT-6W2+ (1438)	30-6000 MHz	4/6/2021	4/6/2022
<input type="checkbox"/> Attenuator	Mini-Circuits	VAT-6W2+ (1736)	30-6000 MHz	4/6/2021	4/6/2022
<input checked="" type="checkbox"/> Weather station	Davis	6312 (A81120N075)		11/4/2020	11/4/2021

Rogers Labs, Inc.  
 4405 W. 259th Terrace  
 Louisburg, KS 66053  
 Phone/Fax: (913) 837-3214  
 Revision 1

SAF Tehnika AS  
 PMN: Aranet4 PRO HVIN: TDSPC0U3.042, TDSPC0U3.043, TDSPC0U3.044  
 Test: 211216 FCC ID: W9Z-A4MK3PRO IC: 8855A-A4MK3PRO  
 Test to: CFR47 15C, RSS-Gen RSS-247 Date: February 1, 2022  
 File: SAF A4MK3PRO DSS TstRpt 211216 Page 46 of 49



List of Test Equipment

	Calibration	Date (m/d/y)	Due
<input type="checkbox"/> Antenna: Schwarzbeck Model VHBB 9124 (9124-627)		4/21/2020	4/21/2022
<input type="checkbox"/> Antenna: Schwarzbeck Model: VULP 9118 A (VULP 9118 A-534)		4/21/2020	4/21/2022
<input type="checkbox"/> Frequency Counter: Leader LDC-825 (8060153)		4/6/2021	4/6/2022
<input type="checkbox"/> LISN: Com-Power Model LI-220A		10/14/2020	10/14/2022
<input type="checkbox"/> LISN: Com-Power Model LI-550C		10/14/2020	10/14/2022
<input type="checkbox"/> ISN: Com-Power Model ISN T-8		4/6/2021	4/6/2022
<input type="checkbox"/> LISN: Fischer Custom Communications Model: FCC-LISN-50-16-2-08		4/6/2021	4/6/2022
<input type="checkbox"/> Cable Huber & Suhner Inc. Sucoflex102ea(1.5M)(303072) 9kHz-40 GHz		10/14/2021	10/14/2022
<input type="checkbox"/> Cable Huber & Suhner Inc. Sucoflex102ea(L1M)(281183) 9kHz-40 GHz		10/14/2021	10/14/2022
<input type="checkbox"/> Cable Huber & Suhner Inc. Sucoflex102ea(L4M)(281184) 9kHz-40 GHz		10/14/2021	10/14/2022
<input type="checkbox"/> Cable Huber & Suhner Inc. Sucoflex102ea(L10M)(317546)9kHz-40 GHz		10/14/2021	10/14/2022
<input type="checkbox"/> Cable Time Microwave 4M-750HF290-750 (4M) 9kHz-24 GHz		10/14/2021	10/14/2022
<input type="checkbox"/> RF Filter Micro-Tronics BRC17663 (001) 9.3-9.5 notch 30-1800 MHz		4/6/2021	4/6/2022
<input type="checkbox"/> RF Filter Micro-Tronics BRC19565 (001) 9.2-9.6 notch 30-1800 MHz		10/16/2018	4/6/2022
<input type="checkbox"/> Analyzer HP 8562A (3051A05950) 9kHz-125GHz		4/6/2021	4/6/2022
<input type="checkbox"/> Wave Form Generator Keysight 33512B (MY57400128)		4/21/2020	4/6/2022
<input type="checkbox"/> Antenna: Solar 9229-1 & 9230-1		2/22/2021	2/22/2022
<input type="checkbox"/> CDN: Com-Power Model CDN325E		10/14/2021	10/14/2022
<input type="checkbox"/> Injection Clamp Luthi Model EM101		10/14/2021	10/14/2022
<input type="checkbox"/> Oscilloscope Scope: Tektronix MDO 4104		2/22/2021	2/22/2022
<input type="checkbox"/> EMC Transient Generator HVT TR 3000		2/22/2021	2/22/2022
<input type="checkbox"/> AC Power Source (Ametech, California Instruments)		2/22/2021	2/22/2022
<input type="checkbox"/> Field Intensity Meter: EFM-018		2/22/2021	2/22/2022
<input type="checkbox"/> ESD Simulator: MZ-15		2/22/2021	2/22/2022
<input type="checkbox"/> R.F. Power Amp ACS 230-50W			not required
<input type="checkbox"/> R.F. Power Amp EIN Model: A301			not required
<input type="checkbox"/> R.F. Power Amp A.R. Model: 10W 1010M7			not required
<input type="checkbox"/> R.F. Power Amp A.R. Model: 50U1000			not required
<input type="checkbox"/> Tenney Temperature Chamber			not required
<input checked="" type="checkbox"/> Shielded Room			not required

Rogers Labs, Inc.  
 4405 W. 259th Terrace  
 Louisburg, KS 66053  
 Phone/Fax: (913) 837-3214  
 Revision 1

SAF Tehnika AS  
 PMN: Aranet4 PRO  
 Test: 211216 FCC ID: W9Z-A4MK3PRO  
 Test to: CFR47 15C, RSS-Gen RSS-247  
 File: SAF A4MK3PRO DSS TstRpt 211216

S/N's: 329970010628 - 329970010630  
 HVIN: TDSPC0U3.042, TDSPC0U3.043, TDSPC0U3.044  
 IC: 8855A-A4MK3PRO  
 Date: February 1, 2022  
 Page 47 of 49

## **Annex C Rogers Qualifications**

**Scot D. Rogers, Engineer**

### **Rogers Labs, Inc.**

Mr. Rogers has over 35 years' experience in the field of electronics. Engineering experience includes six years in the automated controls industry and remaining years working with the design, development and testing of radio communications and electronic equipment.

#### Positions Held:

Systems Engineer: A/C Controls Mfg. Co., Inc.

Electrical Engineer: Rogers Consulting Labs, Inc.

Electrical Engineer: Rogers Labs, Inc. Current

#### Educational Background:

Bachelor of Science Degree in Electrical Engineering from Kansas State University

Bachelor of Science Degree in Business Administration Kansas State University

Several Specialized Training courses and seminars pertaining to Microprocessors and Software programming



**Annex D Laboratory Certificate of Accreditation**

United States Department of Commerce  
National Institute of Standards and Technology



**Certificate of Accreditation to ISO/IEC 17025:2017**

NVLAP LAB CODE: 200087-0

**Rogers Labs, Inc.**  
Louisburg, KS

*is accredited by the National Voluntary Laboratory Accreditation Program for specific services,  
listed on the Scope of Accreditation, for:*

**Electromagnetic Compatibility & Telecommunications**

*This laboratory is accredited in accordance with the recognized International Standard ISO/IEC 17025:2017.  
This accreditation demonstrates technical competence for a defined scope and the operation of a laboratory quality  
management system (refer to joint ISO-ILAC-IAF Communique dated January 2009).*

2021-02-19 through 2022-03-31  
Effective Dates

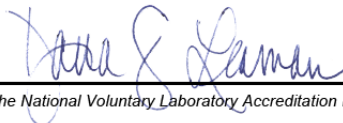

  
For the National Voluntary Laboratory Accreditation Program