

Submittal Application Report

For Grant of Certification

Model: CFL Sprint MXM Repeater
5739-5836 MHz
U-NII Transceiver
Unlicensed National Information Infrastructure
(U-NII) Point-to-Point Operation Device
U-NII-3 Operation (New Rules)
FCC ID: W9Z-58F2DMXMR
IC: 8855A-58F2DMXMR

FOR

SAF Tehnika AS

24a, Ganibu dambis
Riga Latvia LV-1005

Test Report Number: 170615A
FCC Designation: US5305, Registration number: 315994
IC Test Site Registration: 3041A-1

Authorized Signatory: *Scot D. Rogers*
Scot D. Rogers

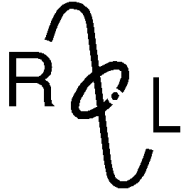

ROGERS LABS, INC.

4405 West 259th Terrace
Louisburg, KS 66053
Phone / Fax (913) 837-3214

Engineering Test Report for Grant of Certification Application

FOR

U-NII Transceiver

Unlicensed National Information Infrastructure
(U-NII) Point-to-Point Operation Device

47CFR, Part 15E 15.407 (New Rules)

Industry Canada RSS-247 Issue 2

License Exempt Intentional Radiator

For

SAF Tehnika AS

24a, Ganību dambis
Rīga Latvia LV-1005

Broadband Digital U-NII Transceiver

Model: CFL Sprint MXM Repeater
Frequency Range 5739-5836 MHz
FCC ID: W9Z-58F2DMXMR
IC: 8855A-58F2DMXMR

Test Date: June 15, 2017

Certifying Engineer: *Scot D. Rogers*

Scot D. Rogers
Rogers Labs, Inc.
4405 West 259th Terrace
Louisburg, KS 66053
Telephone/Facsimile: (913) 837-3214

This report shall not be reproduced except in full, without the written approval of the laboratory.
This report must not be used by the client to claim product certification, approval, or
endorsement by NVLAP, NIST, or any agency of the Federal Government.

Table of Contents

TABLE OF CONTENTS..... 3

REVISIONS..... 8

FOREWORD..... 9

OPINION / INTERPRETATION OF RESULTS 10

EQUIPMENT TESTED..... 11

EQUIPMENT FUNCTION AND CONFIGURATION..... 12

Equipment Use Configuration14

APPLICANT COMPANY INFORMATION 15

EQUIPMENT INFORMATION..... 15

Product Details16

Accessories16

Table for Filed Antennas16

Test Result of Occupied Bandwidth16

APPLICATION FOR CERTIFICATION..... 17

APPLICABLE STANDARDS & TEST PROCEDURES 18

EQUIPMENT TESTING PROCEDURES 19

AC Line Conducted Emission Test Procedure19

Radiated Emission Test Procedure.....19

 Diagram 1 Test arrangement for Conducted emissions20

 Diagram 2 Test arrangement for radiated emissions of tabletop equipment.....21

 Diagram 3 Test arrangement for radiated emissions tested on Open Area Test Site (OATS).....22

TEST SITE LOCATIONS 22

LIST OF TEST EQUIPMENT 23

UNITS OF MEASUREMENTS 24

ENVIRONMENTAL CONDITIONS..... 24

INTENTIONAL RADIATORS..... 24

 Operation in the 5725-5850 MHz Frequency U-NII-3 Bands.....25

TEST #1 MAXIMUM CONDUCTED OUTPUT POWER 15.407(A)(3) 26

 Methods of Measurement Conducted Output Power26

 Test Arrangement Conducted Output Power.....28

§15.407(a)(3) General technical requirements.....29

 Table 1 Maximum Conducted Output Power Data measured on Power Meter30

 Figure 1 Plot of Antenna Port Power (28 MHz Channel, 4QAM).....31

 Figure 2 Plot of Antenna Port Power (28 MHz Channel, 16QAM).....31

 Figure 3 Plot of Antenna Port Power (28 MHz Channel, 32QAM).....32

 Figure 4 Plot of Antenna Port Power (28 MHz Channel, 64QAM).....32

 Figure 5 Plot of Antenna Port Power (28 MHz Channel, 128QAM).....33

 Figure 6 Plot of Antenna Port Power (30 MHz Channel, 4QAM).....33

 Figure 7 Plot of Antenna Port Power (30 MHz Channel, 16QAM).....34

 Figure 8 Plot of Antenna Port Power (30 MHz Channel, 32QAM).....34

 Figure 9 Plot of Antenna Port Power (30 MHz Channel, 64QAM).....35

 Figure 10 Plot of Antenna Port Power (30 MHz Channel, 128QAM).....35

 Figure 11 Plot of Transmitter Operation Across 5725-5850 MHz Band (28 MHz Channel)36

 Figure 12 Plot of Transmitter Operation Across 5725-5850 MHz Band (30 MHz Channel)36

TEST #2 MAXIMUM POWER SPECTRAL DENSITY 15.407(A)(3) 37

 Methods of Measurement power spectral density37

 Test Arrangement power spectral density38

§15.407(a)(3) General technical requirements39

Table 2 Maximum power spectral density data40

Figure 13 Plot of Power Spectral Density (28 MHz Channel 4QAM)41

Figure 14 Plot of Power Spectral Density (28 MHz Channel 16QAM)41

Figure 15 Plot of Power Spectral Density (28 MHz Channel 32QAM)42

Figure 16 Plot of Power Spectral Density (28 MHz Channel 64QAM)42

Figure 17 Plot of Power Spectral Density (28 MHz Channel 128QAM)43

Figure 18 Plot of Power Spectral Density (30 MHz Channel 4QAM)43

Figure 19 Plot of Power Spectral Density (30 MHz Channel 16QAM)44

Figure 20 Plot of Power Spectral Density (30 MHz Channel 32QAM)44

Figure 21 Plot of Power Spectral Density (30 MHz Channel 64QAM)45

Figure 22 Plot of Power Spectral Density (30 MHz Channel 128QAM)45

TEST #3 UNDESIRABLE EMISSIONS 15.407(B)(4) CONDUCTED 46

Methods of Measurement Undesirable emissions.....46

Test Arrangement antenna port conducted Undesirable emissions47

§15.407(b)(4) Undesirable emission limits.....48

Figure 23 Plot of Undesirable emissions (28 MHz Channel)49

Figure 24 Plot of Undesirable emissions (30 MHz Channel)49

Figure 25 Plot of Undesirable emissions (328 MHz Channel)50

Figure 26 Plot of Undesirable emissions (30 MHz Channel)50

TEST #4 UNDESIRABLE EMISSIONS 15.407(B)(4) RADIATED..... 51

Methods of Measurement Undesirable emissions.....51

Test Arrangement Radiated Undesirable emissions53

§15.407(b)(4) Undesirable emission limits.....54

Table 3 Undesirable emissions, Radiated Data.....55

TEST #5 MINIMUM 6-DB BANDWIDTH 15.407(E) 56

Methods of Measurement Minimum 6-dB Bandwidth56

Test Arrangement Minimum 6-dB Bandwidth57

§15.407(e) General technical requirements58

Table 4 Minimum 6-dB Bandwidth data58

Figure 27 Plot of Minimum 6-dB Bandwidth (28 MHz Channel).....59

Figure 28 Plot of 99% OBW (28 MHz Channel)59

Figure 29 Plot of 26-dB OBW (28 MHz Channel).....60

Figure 30 Plot of Minimum 6-dB Bandwidth (30 MHz Channel).....60

Figure 31 Plot of Transmitter 99% OBW (30 MHz Channel).....61

Figure 32 Plot of 26-dB OBW (30 MHz Channel).....61

TEST #6 FREQUENCY STABILITY 15.407(G) 62

Methods of Measurement Frequency Stability62

Test Arrangement Frequency Stability63

§15.407(g) General technical requirements63

Table 5 Frequency Stability vs. Temperature data64

Table 6 Frequency Stability vs. Input Power Supply Voltage data64

TEST #7 ANTENNA REQUIREMENTS 15.203 65

§15.203 Antenna requirement.65

**TEST #8 RADIATED EMISSIONS IN RESTRICTED BANDS OF OPERATION 15.205
 66**

Methods of Measurement Radiated Emissions in Restricted Bands66

Test Arrangement Radiated Emissions in Restricted Bands.....67

§15.407 General technical requirements.....68

§ 15.205 Restricted bands of operation.68

Table 7 Radiated Emissions in Restricted Bands Data69

Summary of Results for Radiated Emissions in Restricted Bands69

TEST #9 AC LINE CONDUCTED EMISSIONS 15.207 70

Methods of Measurement AC Line Conducted Emissions70

Test Arrangement AC Line Conducted Emissions71

§15.407 General technical requirements.....72

§15.207 Conducted limits.....72

Table 8 AC Line Conducted Emissions Data (Highest Emissions Line L1)73

Table 9 AC Line Conducted Emissions Data (Highest Emissions Line L2)73

Figure 33 Plot of AC Line Conducted Emissions Line 174

Figure 34 Plot of AC Line Conducted Emissions Line 274

Summary of Results for AC Line Conducted Emissions75

TEST #10 RADIATED EMISSIONS, GENERAL REQUIREMENTS 15.209..... 76

Methods of Measurement Radiated Emissions, General requirements76

Test Arrangement Radiated Emissions78

§15.407 General technical requirements.....79

§15.209 Radiated emission limits; general requirements.79

Table 10 General Radiated Emissions from EUT Data (Highest Emissions)80

Summary of Results for General Radiated Emissions80

SUMMARY OF RESULTS FOR TRANSMITTER RADIATED EMISSIONS OF INTENTIONAL RADIATOR 81

STATEMENT OF MODIFICATIONS AND DEVIATIONS 81

ANNEX..... 82

Annex A Measurement Uncertainty Calculations.....83

Annex B Rogers Labs Test Equipment List.....84

Annex C Rogers Qualifications85

Annex D Rogers Labs Certificate of Accreditation86

Revisions

Revision 2 Issued November 29, 2017 - updated report at request from FCC
Revision 1 Issued November 16, 2017

Foreword

The following information is submitted for consideration in obtaining Equipment Grant of Certification for License Exempt, U-NII, Unlicensed National Information Infrastructure (U-NII) Intentional Radiator operating under 47CFR Paragraph 15E (15.407), U-NII-3 new rules in the 5725-5850 MHz bands, and Industry Canada RSS-GEN Issue 4, and RSS-247 Issue 2, LE-LAN transmitter.

Name of Applicant: SAF Tehnika AS FRN: 0018662312
24a, Ganibu dambis
Riga Latvia LV-1005

Models: PMN: CFL Sprint MXM Repeater (models: I06E1218L, I06E1218H, I06M1218L, I06M1218H, I06S1218L, I06S1218H, I06E2118L, I06E2118H, I06M2118L, I06M2118H, I06S2118L, and I06S2118H)

FCC ID: W9Z-58F2DMXMR **IC:** 8855A-58F2DMXMR

Frequency Range: 5739-5836 MHz (U-NII-3 under new rules 15.407), power is manufacturer or installer adjustable from 8-25 dBm

Maximum Power: U-NII-3 Band, 28 MHz mode, 0.452-watt, 99% OBW 27,550 kHz
U-NII-3 Band, 30 MHz mode, 0.454-watt, 99% OBW 27,450 kHz

Opinion / Interpretation of Results

Test Number	Measurement	FCC Rule	Pass/Fail
#1	Maximum Conducted Output Power	15.407(a)(3)	Pass
#2	Maximum power spectral density	15.407(a)(3)	Pass
#3	Undesirable emission limits	15.407(b)(4)	Pass
#4	Minimum 6 dB bandwidth	15.407(e)	Pass
#5	Frequency stability	15.407(g)	Pass
#6	Antenna Requirement	15.203	Pass
#7	Radiated emission in restricted Bands	15.205, 15.407(b)(7)	Pass
#8	AC Line Conducted Emissions	15.207, 15.407(b)(6)	Pass
#9	General Radiated Emission	15.209, 15.407(b)(6)	Pass

Tests Performed	Margin (dB)	Results
Restricted Frequency Bands 15.205, RSS-GEN 8.10	-14.4	Complies
AC Line Conducted 15.207, RSS-GEN 7.2.4	-4.1	Complies
Radiated Emissions 15.209, RSS-GEN 7.2.5	-3.5	Complies
Harmonic Emissions per 15.407, RSS-247	-21.6	Complies
Power Spectral Density per 15.407, RS-247	-7.9	Complies

Equipment Tested

<u>Equipment</u>	<u>Model</u>	<u>FCC ID</u>
EUT	CFL Sprint MXM Repeater	W9Z-58F2DMXMR
MSU (Monitoring and Switching Unit	I0GMSU02	N/A
IDU (In Door Unit)	S0GIPT01	N/A
AC Adapter	I0AB4811	N/A
AC Adapter	I0AB4811	N/A
Dell Latitude E6520	6CB35Q1	N/A

Test results in this report relate only to the items tested.

Models Numbers

I06E1218L and I06E1218H
 I06M1218L and I06M1218H
 I06S1218L and I06S1218H
 I06E2118L and I06E2118H
 I06M2118L and I06M2118H
 I06S2118L and I06S2118H

Models used during testing were the I06E2118L and I06E2118H

Antenna options

5 GHz antenna

Dish Antenna manufactured by radiowaves model: HPD8-5.2 41.2 dBi gain High Performance Parabolic Reflector Antenna. Note, antennas of same style and lower gain than 41.2 dBi may also be used with the product.

Equipment Function and Configuration

The EUT is a 5 GHz Digital Point-to-Point Transmission System. The design provides operational capabilities in the U-NII-3 band of 5739-5836 MHz. The CFL Sprint MXM Repeater is designed as Outdoor Unit (ODU) providing for long distance Point-to-Point, high data rate, digital communication transmissions. The design provides multiple modulation options to maintain the communications link. The design may auto-select modulation or it may be set during installation to allow for longer distance link. The product offers multiple options for channel width providing high data rates and long-distance point-to-point configurations. While the design operates in the U-NII-3 frequency band, it does not communicate with typical U-NII-3 equipment. The EUT requires direct current power supplied from a AC/DC power supply. A typical installation would use a low side transmitter at one location and high side transmitter at the next providing full duplex communications. All up and down conversions are processed in the EUT supplying the MSU digital data. The MSU provides switching and monitoring of data and supplies the data to the Indoor Unit (IDU) for distribution over the local network. Software was provided internal to the EUT which provided the ability to set test channel, operational mode, and modulation scheme. The system supports single antenna port for use with authorized antennas as documented in this report. The EUT provides two n-connection ports for transmit/receive communications to the Monitoring and Switching Unit (MSU), BNC and network port for installation use which provides installer to monitor the RSSI, DC power ports and single female n-connector port for antenna connection. The coaxial cable communications ports provide duplex communications path to the MSU, the BNC port is provided for setup and ability to monitor RSSI (Received Signal Strength Indicator), and the antenna n-connector allows connection to antenna and the power port provides connection to direct current power source. For testing purposes, the EUT transceiver was connected to the manufacturer supplied MSU and AC/DC power supply. A laptop computer was connected to the EUT network port which provided communications and control to the EUT for testing purposes. This configuration provided operational control of the EUT and communications over the network interface between the EUT, IDU, MSU and supporting computer system. The EUT provides no other interfacing options than those presented in this report. For

testing purposes, the CFL Sprint MXM Repeater test samples were configured to transmit in available data modes receiving power from the AC/DC power adapter. As requested by the manufacturer and required by regulations, the equipment was tested for emissions compliance using the available configurations with the worst-case data presented. Test results in this report relate only to the products described in this report.

Equipment Use Configuration

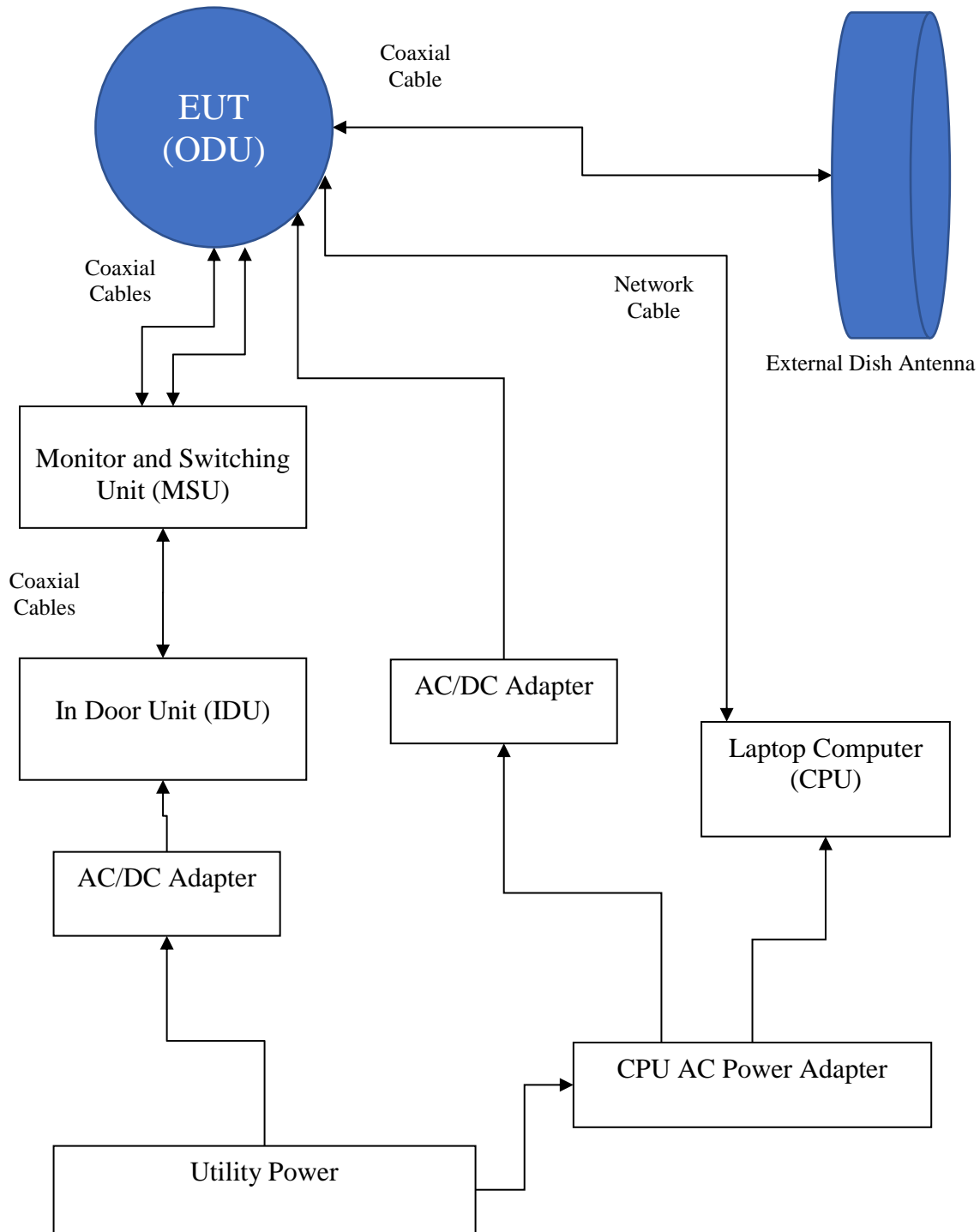

Applicant Company information

Applicants Company	SAF Tehnika AS
Applicants Address	24a, Ganibu dambis, Riga Latvia LV-1005
FCC ID:	W9Z-58F2DMXMR
Industry Canada Identifier	8855A-58F2DMXMR
Manufacturer Company	SAF Tehnika AS
Manufacturer Address	24a, Ganibu dambis, Riga Latvia LV-1005

Equipment information

<p>Product Marketing Name (PMN):</p> <p>The PMN is the name or model number under which the product will be marketed/offered for sale in Canada. If the product has PMN, it must be provided.</p>	CFL Sprint MXM Repeater
<p>Unique Product Number (UPN):</p> <p>The applicant, made up of a maximum of 11 alphanumeric characters (A-Z, 0-9), assigns the UPN.</p>	58F2DMXMR
<p>Hardware Version Identification Number (HVIN):</p> <p>The HVIN identifies hardware specifications of a product version. The HVIN replaces the ISED Model Number in the legacy E-filing System. An HVIN is required for all products for certification applications.</p>	58F2DMXMR
<p>Host Marketing Name (HMN) (if applicable):</p> <p>The HMN is the name or model number of a final product, which contains a certified radio module.</p>	
Brand Name	
Model Number	I06E1218L and I06E1218H I06M1218L and I06M1218H I06S1218L and I06S1218H I06E2118L and I06E2118H I06M2118L and I06M2118H I06S2118L and I06S2118H
Test Rule Part(s)	47CFR 15E, 15.407, RSS-247
Test Frequency Range	5.725-5.85 GHz
Project Number	170615A
Submission Type	Certification

Product Details

Items	Description
Product Type	5 GHz U-NII-3 Point-To-Point Digital Transmission System
Radio Type	Transceiver
Power Type	Direct current provided from In Door Unit
Frequency Range	5725-5850 MHz
Maximum Conducted Output Power	Average 0.454 Watts Peak output power 1.0 Watts
Antenna	External antenna options include: Dish Antenna (42.1 dBi) HPD8-5.2

Accessories

AC/DC Power Supply 48V DC, 80W	I0AB4811
CFL Sprint MSU Mk1(MSU)	I0GSMU02
CFIP PhoeniX IDU (In Door Unit)	S0GIPT01

Table for Filed Antennas

Ant.	Brand	Model Name	P/N	Antenna Type	Connector	Gain (dBi)
1	radiowaves		HPD8-5.2	Dish	n	42.1

Test Result of Occupied Bandwidth

Mode	Frequency	26 dB Bandwidth (kHz)	6 dB Bandwidth (kHz)	99% Occupied Bandwidth (kHz)
28 MHz Channel	5739 MHz	29750 kHz	25450 kHz	27550 kHz
	5834 MHz	29650 kHz	25400 kHz	27300 kHz
	5836 MHz	29650 kHz	25100 kHz	27250 kHz
30 MHz Channel	5755 MHz	29750 kHz	25300 kHz	27450 kHz
	5795 MHz	29650 kHz	25000 kHz	27250 kHz

Application for Certification

- (1) Manufacturer: SAF Tehnika AS
24a, Ganību dambis
Rīga Latvia LV-1005
- (2) Identification: Models: CFL Sprint MXM Repeater
FCC I.D.: W9Z-58F2DMXMR IC: 8855A-58F2DMXMR
- (3) Instruction Book:
Refer to Exhibit for Instruction Manual.
- (4) Description of Circuit Functions:
Refer to Exhibit of Operational Description.
- (5) Block Diagram with Frequencies:
Refer to Exhibit of Operational Description.
- (6) Report of Measurements:
Report of measurements follows in this Report.
- (7) Photographs: Construction, Component Placement, etc.:
Refer to Exhibit for photographs of equipment.
- (8) List of Peripheral Equipment Necessary for operation. The equipment operates from direct current power received from AC/DC power adapter. The EUT provides two Coaxial cable ports for communications with MSU, BNC and network ports for installation and monitoring, DC connection port, and single coaxial antenna port connection. During testing, the EUT was powered from AC/DC power adapter and connected to CPU through the network port.
- (9) Transition Provisions of 47CFR 15.37 are not requested
- (10) Not Applicable. The unit is not a scanning receiver.
- (11) Not Applicable. The EUT does not operate in the 59 – 64 GHz frequency band.
- (12) The equipment is not software defined and this section is not applicable.
- (13) Applications for certification of U-NII devices in the 5.15-5.35 GHz and the 5.47-5.85 GHz bands must include a high-level operational description of the security procedures that control the radio frequency operating parameters and ensure that unauthorized modifications cannot be made. The required information has been provided in Operational Description Exhibit filed with the application.
- (14) Contain at least one drawing or photograph showing the test set-up for each of the required types of tests applicable to the device for which certification is requested. These drawings or photographs must show enough detail to confirm other information contained in the test report. Any photographs used must be focused originals without glare or dark spots and must clearly show the test configuration used. This information is provided in this report and Test Setup Exhibits provided with the application filing.

Applicable Standards & Test Procedures

The following information is submitted in accordance with e-CFR dated June 16, 2017, Part 2, Subpart J, Part 15, Subpart 15E, Industry Canada RSS-GEN issue 4, and RSS-247 Issue 2. Test procedures used are the established Methods of Measurement of Radio-Noise Emissions as described in ANSI C63.10-2013, KDB 789033 D02 v01r04, KDB 926956 v02, RSS-247 Issue 2, and RSS-GEN Issue 4.

- 47CFR Part 15, Subpart 15E, paragraph 15.407
- KDB 789033 D02 General U-NII Test Procedures New Rules v01r04
- 644545 D03 Guidance for IEEE 802.11ac New Rules v01
- 926956 D01 U-NII Transition Plan v02

Equipment Testing Procedures

AC Line Conducted Emission Test Procedure

Testing for the AC line-conducted emissions was performed as defined in ANSI C63.10-2013. The test setup, including the EUT, was arranged in the test configurations as presented during testing. The test configuration was placed on a 1 x 1.5-meter wooden bench, 0.8 meters high located in a screen room. The power lines of the system were isolated from the power source using a standard LISN with a 50- μ Hy choke. EMI was coupled to the spectrum analyzer through a 0.1 μ F capacitor internal to the LISN. The LISN was positioned on the floor beneath the wooden bench supporting the EUT. The power lines and cables were draped over the back edge of the table. Refer to diagram one showing typical test arrangement and photographs in exhibits for EUT placement used during testing.

Radiated Emission Test Procedure

Radiated emission testing was performed as required on a CISPR 16-1-4 compliant OATS and as specified in ANSI C63.10-2013 and applicable KDB documents. The EUT was placed on a rotating 0.9 x 1.2-meter platform, elevated as required above the ground plane at a distance of 3 meters from the FSM antenna. The table permitted orientation of the EUT in each of three orthogonal axis positions if necessary. EMI energy was maximized by equipment placement, raising and lowering the FSM antenna, changing the antenna polarization, and by rotating the turntable. Each emission was maximized before data was taken using a spectrum analyzer. The frequency spectrum from 9 kHz to 60,000 MHz was searched for during preliminary investigation. Refer to diagrams two and three showing typical test arrangement and photographs in the test setup exhibits for specific EUT placement during testing.

A Rohde and Schwarz ESU40 was used as the measuring instrument for radiated emissions testing of frequencies below 1 GHz. A Rohde and Schwarz ESU40 and/or Hewlett Packard 8562A Spectrum Analyzer was used as the measuring instrument emissions above 1 GHz. The analyzer settings used are described in the following table.

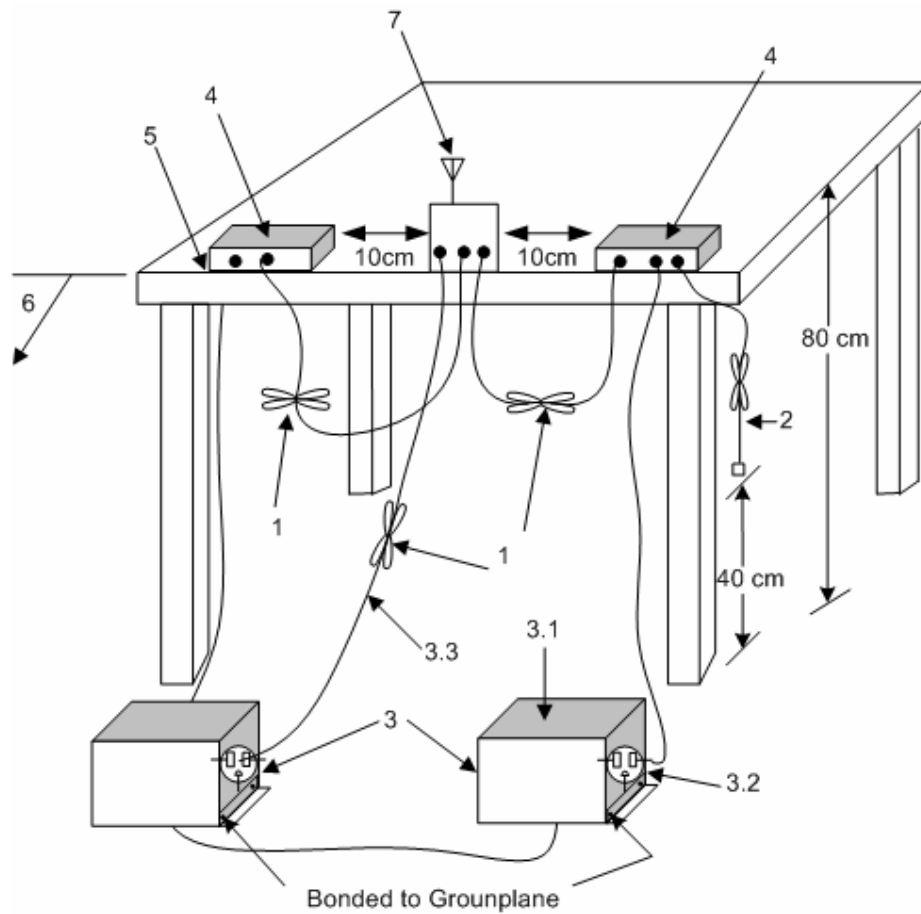

1. Interconnecting cables that hang closer than 40 cm to the ground plane shall be folded back and forth in the center forming a bundle 30 cm to 40 cm long see (see 6.2.3.2).
2. The I/O cables that are not connected to an accessory shall be bundled in the center. The end of the cable may be terminated, if required, using the correct terminating impedance. The overall length shall not exceed 1 m (see 6.2.2).
3. EUT connected to one LISN. Unused LISN measuring port connectors shall be terminated in 50 Ω loads. LISN may be placed on top of, or immediately beneath, reference ground plane (see 6.2.2 and 6.2.3).
 - 3.1 All other equipment powered from additional LISN(s).
 - 3.2 Multiple-outlet strip can be used for multiple power cords of non-EUT equipment.
 - 3.3 LISN at least 80 cm from nearest part of EUT chassis
4. Non-EUT components of EUT system being tested
5. Rear of EUT, including peripherals, shall all be aligned and flush with edge of tabletop (see 6.2.3.2).
6. Edge of tabletop shall be 40 cm removed from a vertical conducting plane that is bonded to the ground plane (see 6.2.2 for options).
7. Antenna may be integral or detachable. If detachable, the antenna shall be attached for this test.

Diagram 1 Test arrangement for Conducted emissions

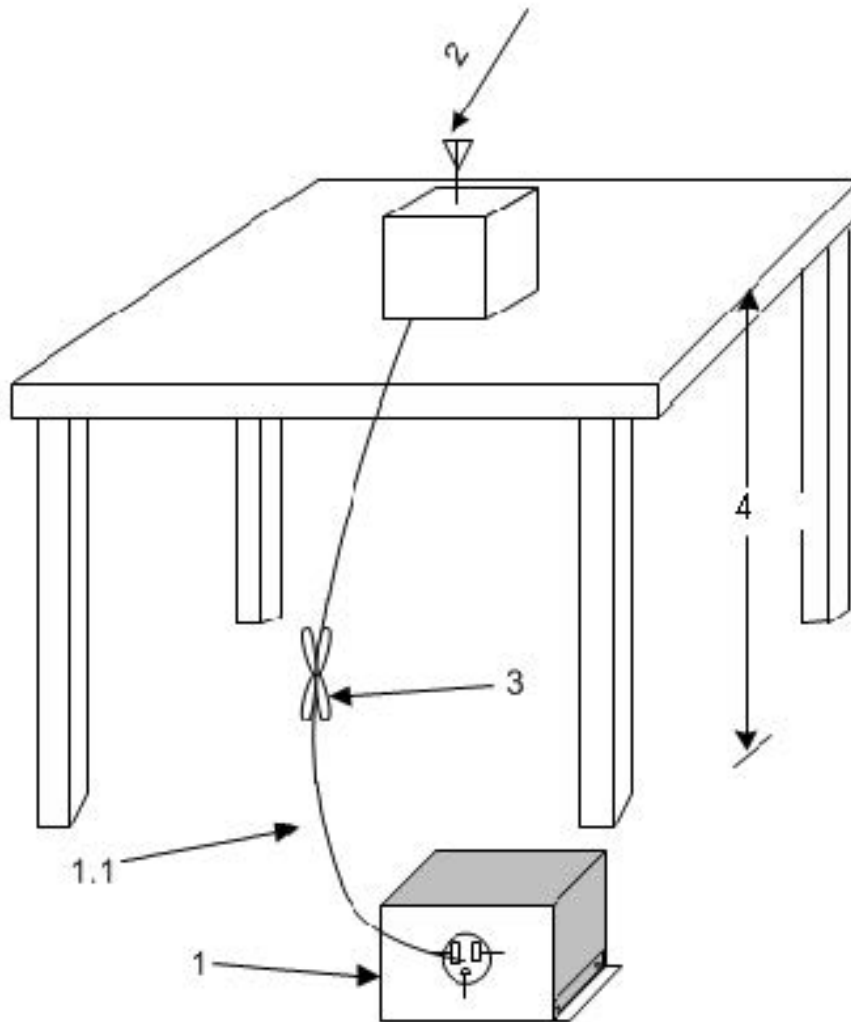

1. A LISN is optional for radiated measurements between 30 MHz and 1000 MHz but not allowed for measurements below 30 MHz and above 1000 MHz (see 6.3.1). If used, then connect EUT to one LISN. Unused LISN measuring port connectors shall be terminated in 50 Ω loads. The LISN may be placed on top of, or immediately beneath, the reference ground plane (see 6.2.2 and 6.2.3.2).
 - 1.1 LISN spaced at least 80 cm from nearest part of EUT chassis.
2. Antenna can be integral or detachable, depending on the EUT (see 6.3.1).
3. Interconnecting cables that hang closer than 40 cm to the ground plane shall be folded back and forth in the center forming a bundle 30 cm to 40 cm long (see 6.3.1).
4. For emission measurements at or below 1 GHz, the table height shall be 80 cm. For emission measurements above 1 GHz, the table height shall be 1.5 m for measurements, except as otherwise specified (see 6.3.1 and 6.6.3.1).

Diagram 2 Test arrangement for radiated emissions of tabletop equipment

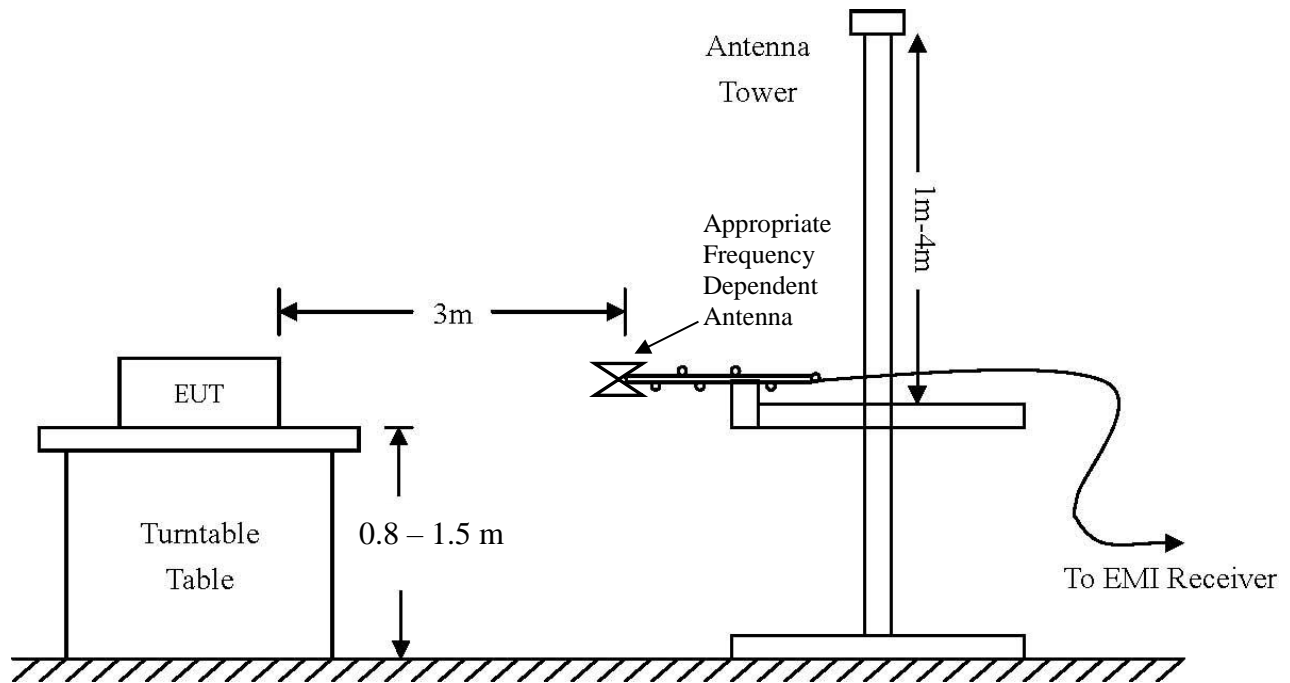

Frequency: 9 kHz-30 MHz	Frequency: 30 MHz- 1 GHz	Frequency: Above 1 GHz
Loop Antenna	Broadband Biconilog	Horn
RBW = 9 kHz	RBW = 120 kHz	RBW = 1 MHz
VBW = 30 kHz	VBW = 120 kHz	VBW = 1 MHz
Sweep time = Auto	Sweep time = Auto	Sweep time = Auto
Detector = PK, QP	Detector = PK, QP	Detector = PK, AV
Antenna Height 1m	Antenna Height 1-4m	Antenna Height 1-4m

Diagram 3 Test arrangement for radiated emissions tested on Open Area Test Site (OATS)

Test Site Locations

Conducted EMI The AC power line conducted emissions testing performed in a shielded screen room located at Rogers Labs, Inc., 4405 West 259th Terrace, Louisburg, KS

Radiated EMI The radiated emissions tests were performed at the 3 meters, Open Area Test Site (OATS) located at Rogers Labs, Inc., 4405 West 259th Terrace, Louisburg, KS

Site Registration Refer to Annex for Site Registration Letters

NVLAP Accreditation Lab code 200087-0

List of Test Equipment

<u>Equipment</u>	<u>Manufacturer</u>	<u>Model (SN)</u>	<u>Band</u>	<u>Cal Date</u>	<u>Due</u>
<input checked="" type="checkbox"/> LISN	FCC	FCC-LISN-50-2-10(1PA) (160611)	.15-30MHz	5/17	5/18
<input checked="" type="checkbox"/> Cable	Time Microwave	750HF290-750 (L10M)	9kHz-40 GHz	10/16	10/17
<input checked="" type="checkbox"/> Cable	Belden	RG-58 (L1-CAT3-11509)	9kHz-30 MHz	10/16	10/17
<input checked="" type="checkbox"/> Cable	Belden	RG-58 (L2-CAT3-11509)	9kHz-30 MHz	10/16	10/17
<input type="checkbox"/> Antenna	ARA	BCD-235-B (169)	20-350MHz	10/16	10/17
<input type="checkbox"/> Antenna	EMCO	3147 (40582)	200-1000MHz	10/16	10/17
<input checked="" type="checkbox"/> Antenna	ETS-Lindgren	3117 (200389)	1-18 GHz	5/17	5/18
<input type="checkbox"/> Antenna	Com Power	AH-118 (10110)	1-18 GHz	10/15	10/17
<input checked="" type="checkbox"/> Antenna	Com Power	AH-840 (101046)	18-40 GHz	5/17	5/18
<input checked="" type="checkbox"/> Antenna	Com Power	AL-130 (121055)	.001-30 MHz	10/16	10/17
<input checked="" type="checkbox"/> Antenna	Sunol	JB-6 (A100709)	30-1000 MHz	10/16	10/17
<input type="checkbox"/> Antenna	EMCO	3143 (9607-1277)	20-1200 MHz	5/17	5/18
<input type="checkbox"/> Analyzer	HP	8591EM (3628A00871)	9kHz-1.8GHz	5/17	5/18
<input type="checkbox"/> Analyzer	HP	8562A (3051A05950)	9kHz-110GHz	5/17	5/18
<input type="checkbox"/> Analyzer	HP External Mixers	11571, 11970	25GHz-110GHz	5/17	5/18
<input checked="" type="checkbox"/> Analyzer	Rohde & Schwarz	ESU40 (100108)	20Hz-40GHz	5/17	5/18
<input checked="" type="checkbox"/> Amplifier	Com-Power	PA-010 (171003)	100Hz-30MHz	10/16	10/17
<input checked="" type="checkbox"/> Amplifier	Com-Power	CPPA-102 (01254)	1-1000 MHz	10/16	10/17
<input checked="" type="checkbox"/> Amplifier	Com-Power	PAM-118A (551014)	0.5-18 GHz	10/16	10/17
<input checked="" type="checkbox"/> Power Meter	Agilent	N1911A with N1921A	0.05-18 GHz	5/17	5/18

Units of Measurements

Conducted EMI Data is in dB μ V; dB referenced to one microvolt

Radiated EMI Data is in dB μ V/m; dB/m referenced to one microvolt per meter

Sample Calculation:

RFS = Radiated Field Strength, FSM = Field Strength Measured

A.F. = Receive antenna factor, Gain = amplification gains and/or cable losses

$RFS (dB\mu V/m @ 3m) = FSM (dB\mu V) + A.F. (dB) - Gain (dB)$

Environmental Conditions

Ambient Temperature 23.1° C

Relative Humidity 47%

Atmospheric Pressure 1006.4 mb

Intentional Radiators

As per 47CFR part 15 subpart E 15.407 and Industry Canada RSS-247 Issue 2, the following information is submitted for consideration and demonstration of compliance with regulations and standards.

Operation in the 5725-5850 MHz Frequency U-NII-3 Bands

Testing followed FCC KDB 789033 D02 General U-NII Test Procedures New Rules v01r04. The test sample provided direct connection to the antenna port. A power meter was used to measure transmitter peak and average fundamental power. A spectrum analyzer / receiver was used to produce plots and make other antenna port conducted measurements for compliance testing. The antenna port was connected to 50-ohm attenuator, coaxial cable and receiver, spectrum analyzer, or power meter during testing. Antenna port conducted testing was performed in a screen room with the EUT placed on a wooden table. The design provides multiple modulations which provide different data rates and transmitter output powers. All modulations were investigated and found the change in modulation did not impact the spectral signature of the transmitter. Radiated emissions testing had the EUT placed on a turntable elevated as required above the ground plane as required at a distance of 3 meters from the FSM antenna located on the OATS (Open Area Test Site). The peak and quasi-peak amplitude of the frequencies below 1000 MHz were measured using a spectrum analyzer. The peak and average amplitude of emissions above 1000 MHz were measured using a spectrum analyzer. Emissions data was recorded from the measurement results. Data presented reflects measurement result corrected to account for measurement system gains and losses. Plots were made of transmitter performance for reference and demonstration of compliance. In addition, all Manufacturers of U-NII devices are responsible for ensuring frequency stability such that an emission is maintained within the band of operation under all conditions of normal operation as specified in the user's manual. The manufacturer has attested the equipment operates within the required frequency spectrum under normal operational conditions. This report documents emissions governed under the U-NII-3 band operating in the 5739-5836 MHz frequency band.

TEST #1 Maximum Conducted Output Power 15.407(a)(3)

The maximum conducted output power measured over any interval of continuous transmission using instrumentation calibrated in terms of an rms-equivalent voltage. Testing was performed as directed in KDB 789033 D02 General UNII Test Procedures New Rules v01r04 using both the spectrum analyzer and Power meter. Both Peak and average power was measured and recorded. Plots were produced of EUT operation across the authorized band. The device transmits on single channel only as determined by channel selection in software. Plots present lowest, near middle and highest channels of operation across the band for each channel width and mode.

Methods of Measurement Conducted Output Power

789033 D02 General UNII Test Procedures New Rules v01r04

E. Maximum Conducted Output Power

Maximum conducted output power may be measured using a spectrum analyzer/EMI receiver or an RF power meter.

1. Device Configuration

If possible, configure or modify the operation of the EUT so that it transmits continuously at its maximum power control level (see II.B.).

a) The intent is to test at 100% duty cycle; however a small reduction in duty cycle (to no lower than 98%) is permitted if required by the EUT for amplitude control purposes. Manufacturers are expected to provide software to the test lab to permit such continuous operation.

b) If continuous transmission (or at least 98% duty cycle) cannot be achieved due to hardware limitations (e.g., overheating), the EUT shall be operated at its maximum power control level with the transmit duration as long as possible and the duty cycle as high as possible.

2. Measurement using a Spectrum Analyzer or EMI Receiver (SA)

Measurement of maximum conducted output power using a spectrum analyzer requires integrating the spectrum across a frequency span that encompasses, at a minimum, either the EBW or the 99% occupied bandwidth of the signal. However, the EBW must be used to determine bandwidth dependent limits on maximum conducted output power in accordance with Section 15.407(a).

a) The test method shall be selected as follows:

(i) Method SA-1 or SA-1 Alternative (averaging with the EUT transmitting at full power throughout each sweep) shall be applied if either of the following conditions can be satisfied:

- The EUT transmits continuously (or with a duty cycle $\geq 98\%$).
- Sweep triggering or gating can be implemented in a way that the device transmits at the maximum power control level throughout the duration of each of the instrument sweeps to be averaged. This condition can generally be achieved by triggering the instrument's sweep if the duration of the sweep (with the analyzer configured as in Method SA-1, below) is equal to or shorter than the duration T of each transmission from the EUT and if those transmissions exhibit full power throughout their durations.

b) **Method SA-1** (trace averaging with the EUT transmitting at full power throughout each sweep):

- (i) Set span to encompass the entire emission bandwidth (EBW) (or, alternatively, the entire 99% occupied bandwidth) of the signal.
- (ii) Set RBW = 1 MHz.
- (iii) Set VBW \geq 3 MHz.
- (iv) Number of points in sweep $\geq 2 \times \text{span} / \text{RBW}$. (This ensures that bin-to-bin spacing is $\leq \text{RBW}/2$, so that narrowband signals are not lost between frequency bins.)
- (v) Sweep time = auto.
- (vi) Detector = power averaging (rms), if available. Otherwise, use sample detector mode.
- (vii) If transmit duty cycle $< 98\%$, use a video trigger with the trigger level set to enable triggering only on full power pulses. Transmitter must operate at maximum power control level for the entire duration of every sweep. If the EUT transmits continuously (i.e., with no off intervals) or at duty cycle $\geq 98\%$, and if each transmission is entirely at the maximum power control level, then the trigger shall be set to “free run.”
- (viii) Trace average at least 100 traces in power averaging (rms) mode.
- (ix) Compute power by integrating the spectrum across the EBW (or, alternatively, the entire 99% occupied bandwidth) of the signal using the instrument’s band power measurement function with band limits set equal to the EBW (or occupied bandwidth) band edges. If the instrument does not have a band power function, sum the spectrum levels (in power units) at 1 MHz intervals extending across the EBW (or, alternatively, the entire 99% occupied bandwidth) of the spectrum.

3. Measurement using a Power Meter (PM)

a) **Method PM** (Measurement using an RF average power meter):

- (i) Measurements may be performed using a wideband RF power meter with a thermocouple detector or equivalent if all of the conditions listed below are satisfied.
 - The EUT is configured to transmit continuously or to transmit with a constant duty cycle.
 - At all times when the EUT is transmitting, it must be transmitting at its maximum power control level.
 - The integration period of the power meter exceeds the repetition period of the transmitted signal by at least a factor of five.
- (ii) If the transmitter does not transmit continuously, measure the duty cycle, x , of the transmitter output signal as described in II.B.
- (iii) Measure the average power of the transmitter. This measurement is an average over both the on and off periods of the transmitter.
- (iv) Adjust the measurement in dBm by adding $10 \log (1/x)$ where x is the duty cycle (e.g., $10 \log (1/0.25)$ if the duty cycle is 25%).

Test Arrangement Conducted Output Power

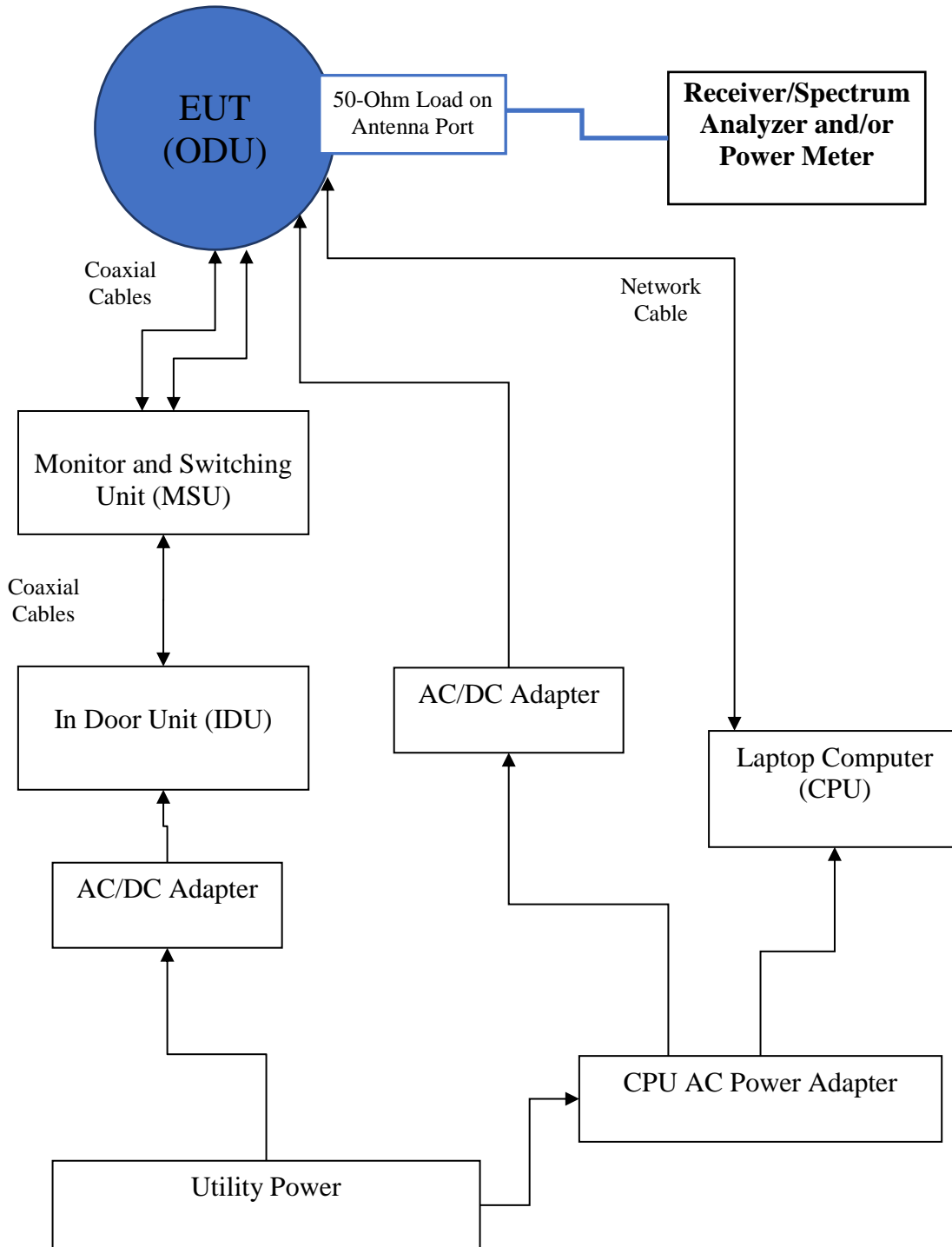

§15.407(a)(3) General technical requirements

(a) Power limits:

(3) For the band 5.725-5.85 GHz, the maximum conducted output power over the frequency band of operation shall not exceed 1 W. In addition, the maximum power spectral density shall not exceed 30 dBm in any 500-kHz band. If transmitting antennas of directional gain greater than 6 dBi are used, both the maximum conducted output power and the maximum power spectral density shall be reduced by the amount in dB that the directional gain of the antenna exceeds 6 dBi. However, fixed point-to-point U-NII devices operating in this band may employ transmitting antennas with directional gain greater than 6 dBi without any corresponding reduction in transmitter conducted power. Fixed, point-to-point operations exclude the use of point-to-multipoint systems, omnidirectional applications, and multiple collocated transmitters transmitting the same information. The operator of the U-NII device, or if the equipment is professionally installed, the installer, is responsible for ensuring that systems employing high gain directional antennas are used exclusively for fixed, point-to-point operations.

Table 1 Maximum Conducted Output Power Data measured on Power Meter

Frequency MHz	Conducted Antenna Port Peak / Average Output Power (Watts)
28 MHz Channel (4QAM)	
5739.0	1.000 / 0.452
5834.0	0.999 / 0.356
5836.0	0.998 / 0.360
28 MHz Channel (16QAM)	
5739.0	0.994 / 0.389
5834.0	0.986 / 0.355
5836.0	0.982 / 0.356
28 MHz Channel (32QAM)	
5739.0	0.952 / 0.267
5834.0	0.945 / 0.325
5836.0	0.944 / 0.316
28 MHz Channel (64QAM)	
5739.0	0.951 / 0.196
5834.0	0.938 / 0.168
5836.0	0.883 / 0.168
28 MHz Channel (128QAM)	
5739.0	0.994 / 0.197
5834.0	0.972 / 0.168
5836.0	0.984 / 0.168
30 MHz Channel (4QAM)	
5740.0	0.999 / 0.454
5835.0	0.997 / 0.345
30 MHz Channel (16QAM)	
5740.0	0.998 / 0.392
5835.0	0.994 / 0.342
30 MHz Channel (32QAM)	
5740.0	0.995 / 0.311
5835.0	0.996 / 0.398
30 MHz Channel (64QAM)	
5740.0	0.999 / 0.195
5835.0	0.998 / 0.179
30 MHz Channel (128QAM)	
5740.0	0.987 / 0.196
5835.0	0.983 / 0.178

Plots were produced for graphical presentation of operation and demonstration of compliance. The EUT operates on single channel defined by installation. Plots were produced using traces for each channel observed addressing the requirement for presenting lowest channel, middle of band, and highest operational channels in the band.

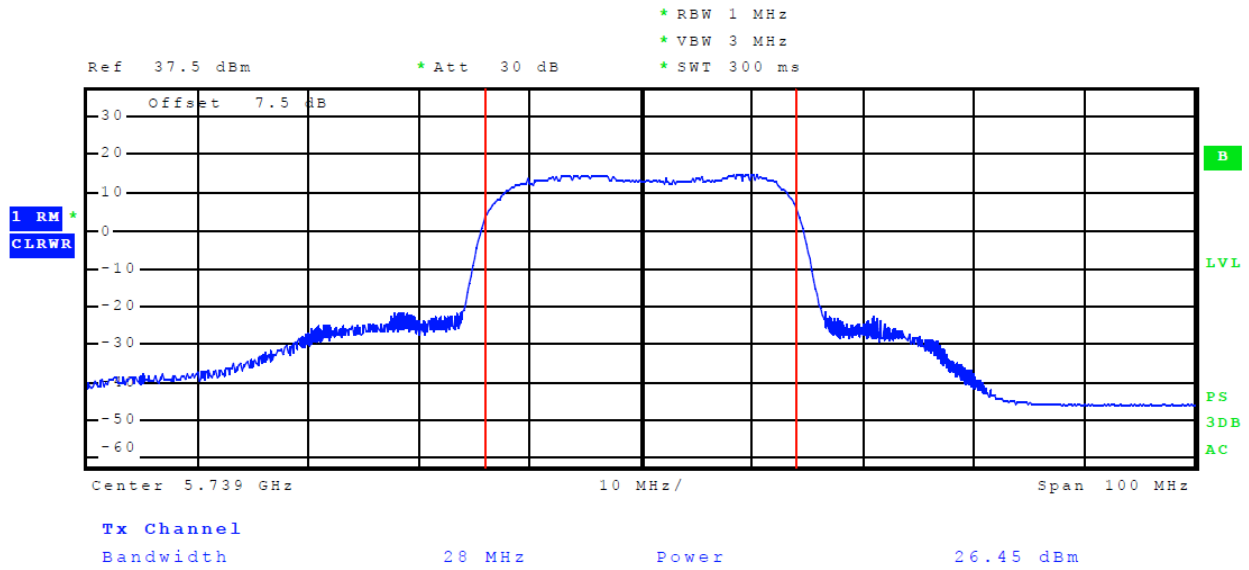

Figure 1 Plot of Antenna Port Power (28 MHz Channel, 4QAM)

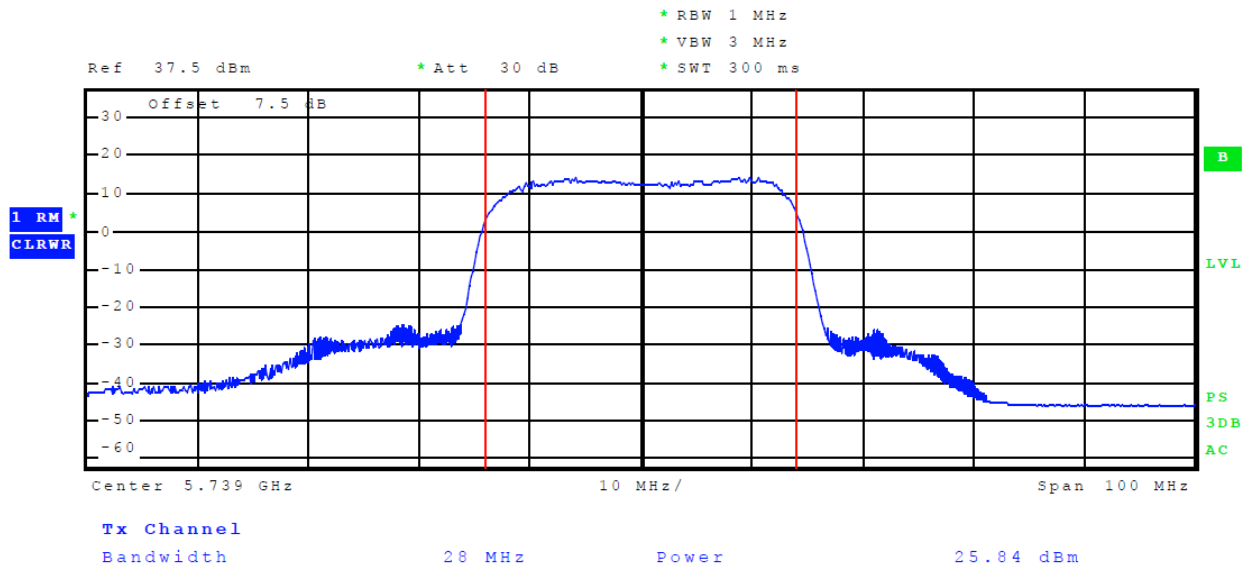

Figure 2 Plot of Antenna Port Power (28 MHz Channel, 16QAM)

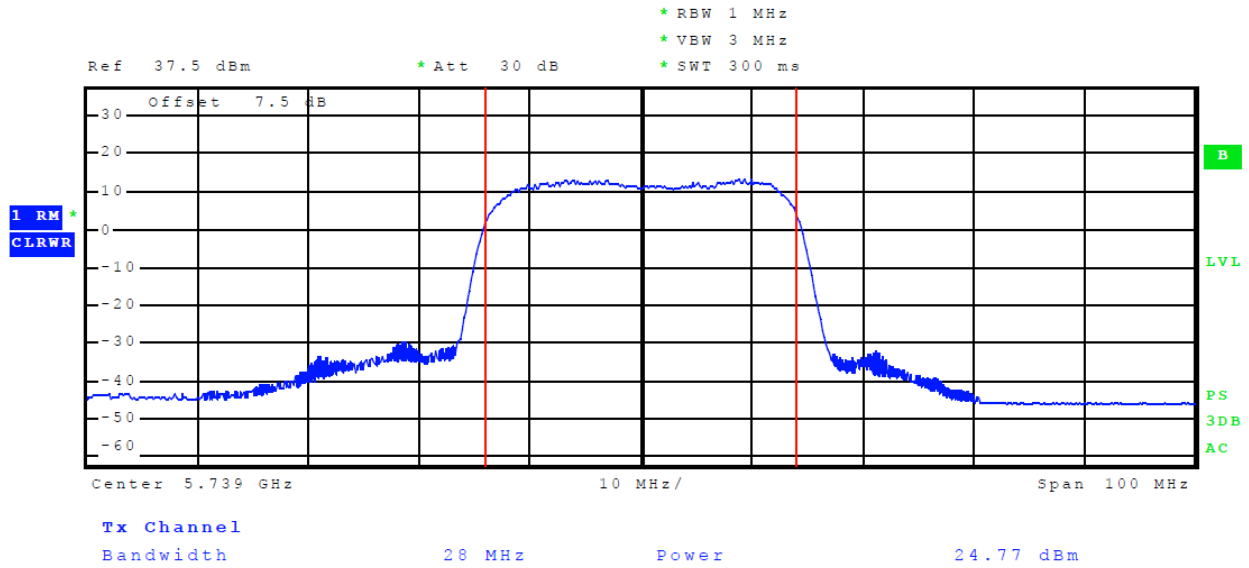

Figure 3 Plot of Antenna Port Power (28 MHz Channel, 32QAM)

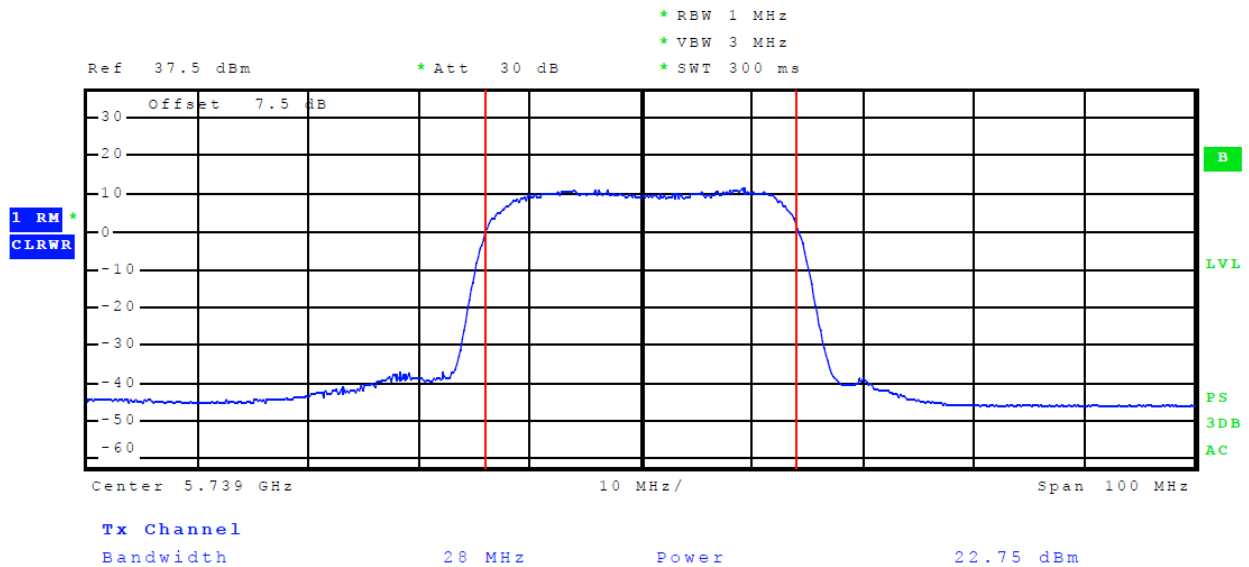

Figure 4 Plot of Antenna Port Power (28 MHz Channel, 64QAM)

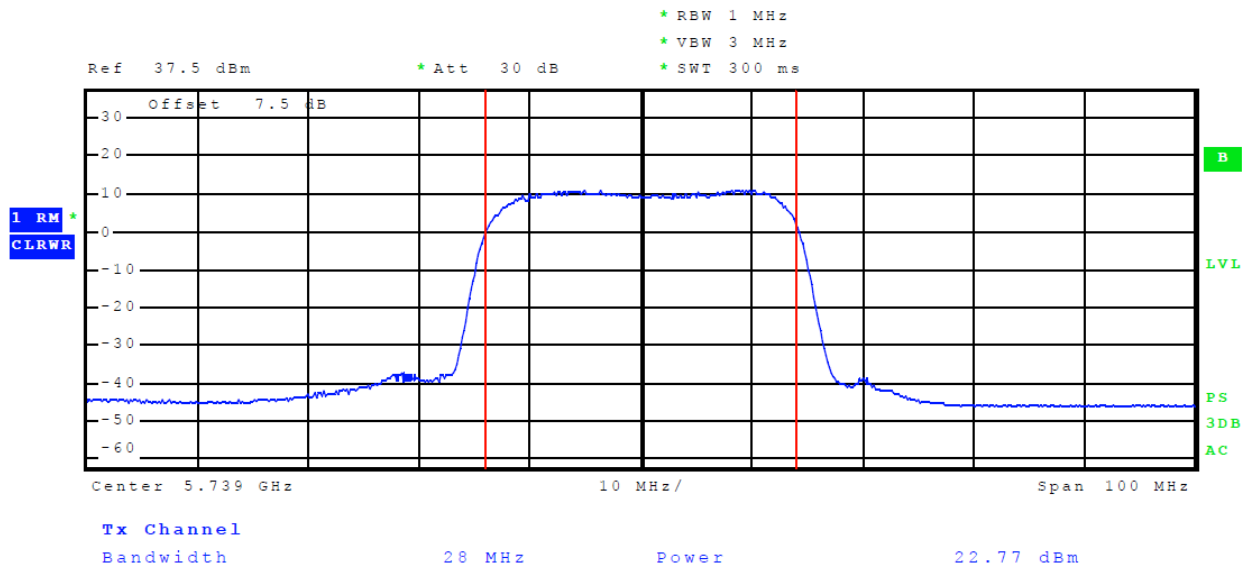

Figure 5 Plot of Antenna Port Power (28 MHz Channel, 128QAM)

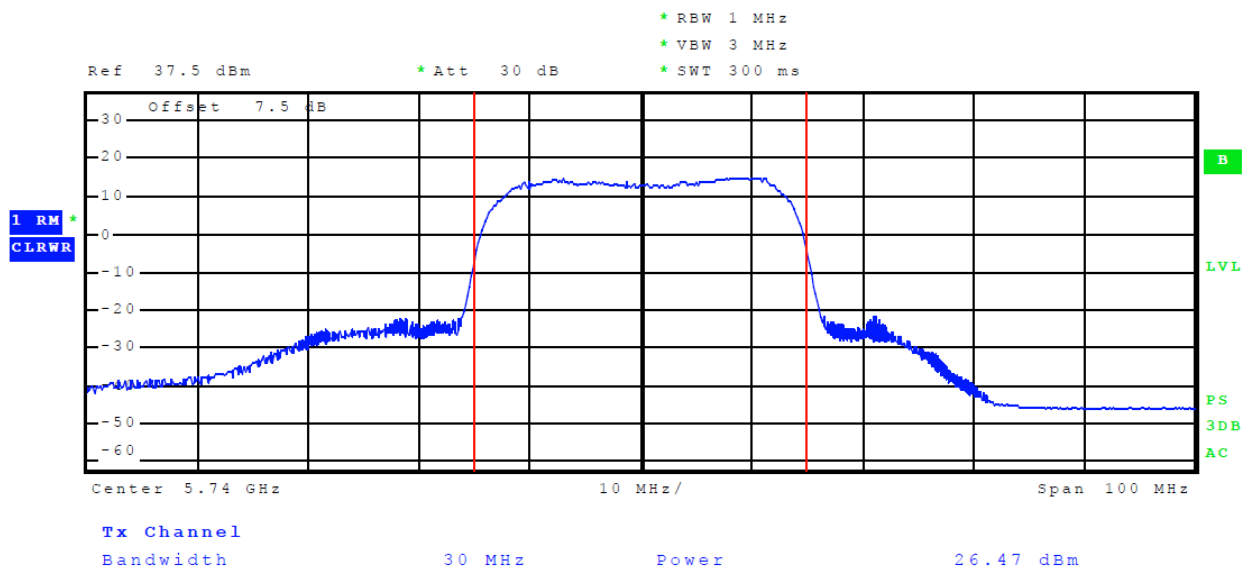

Figure 6 Plot of Antenna Port Power (30 MHz Channel, 4QAM)

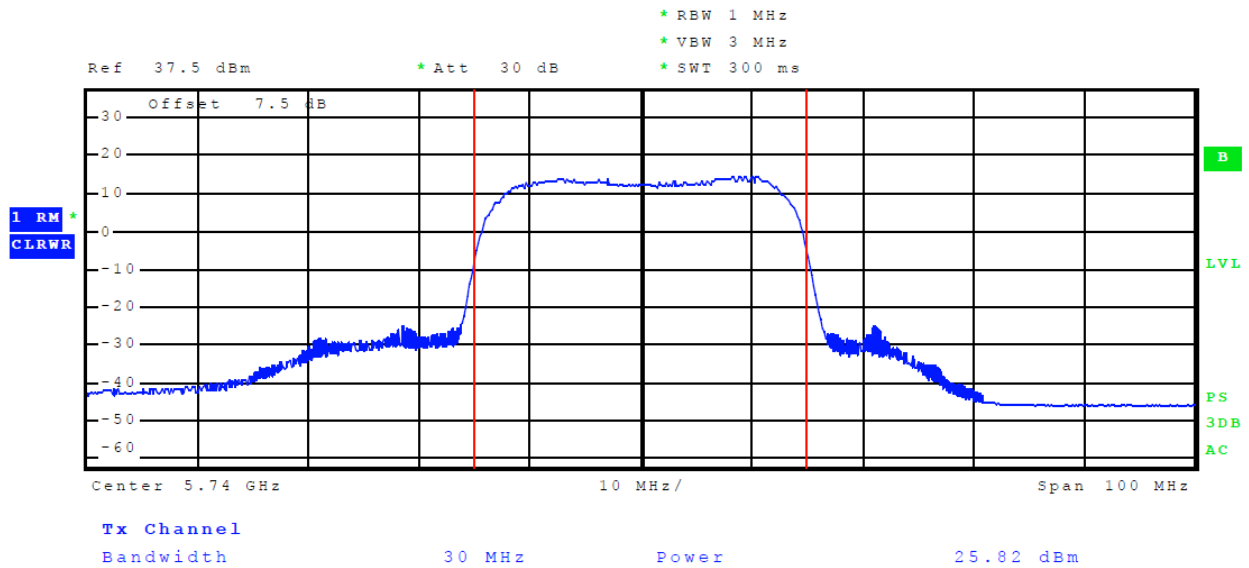

Figure 7 Plot of Antenna Port Power (30 MHz Channel, 16QAM)

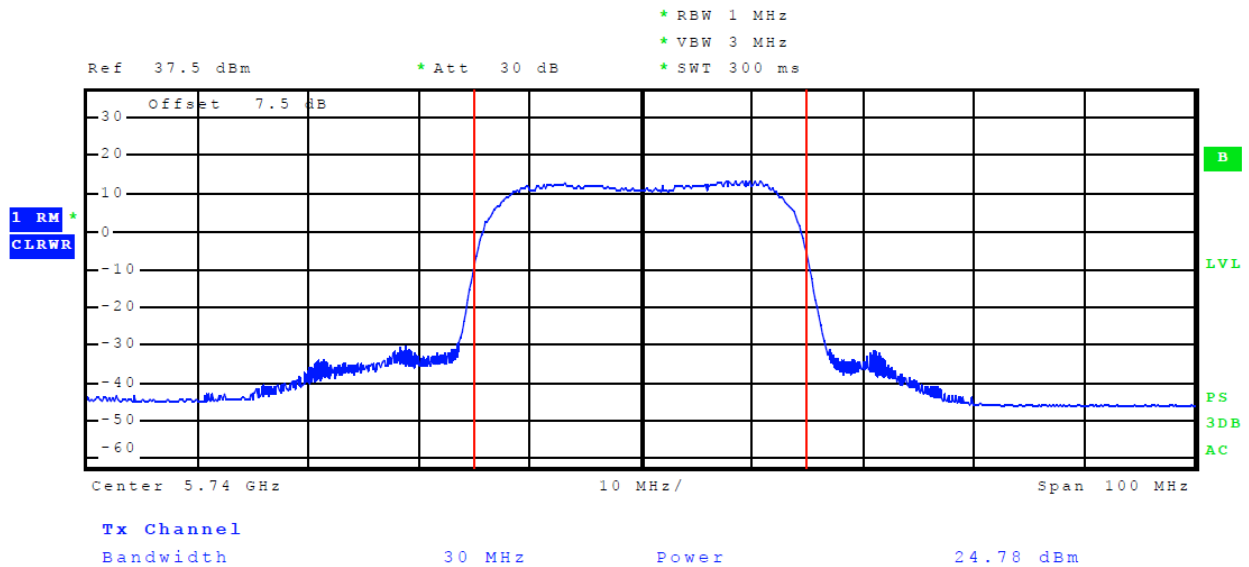

Figure 8 Plot of Antenna Port Power (30 MHz Channel, 32QAM)

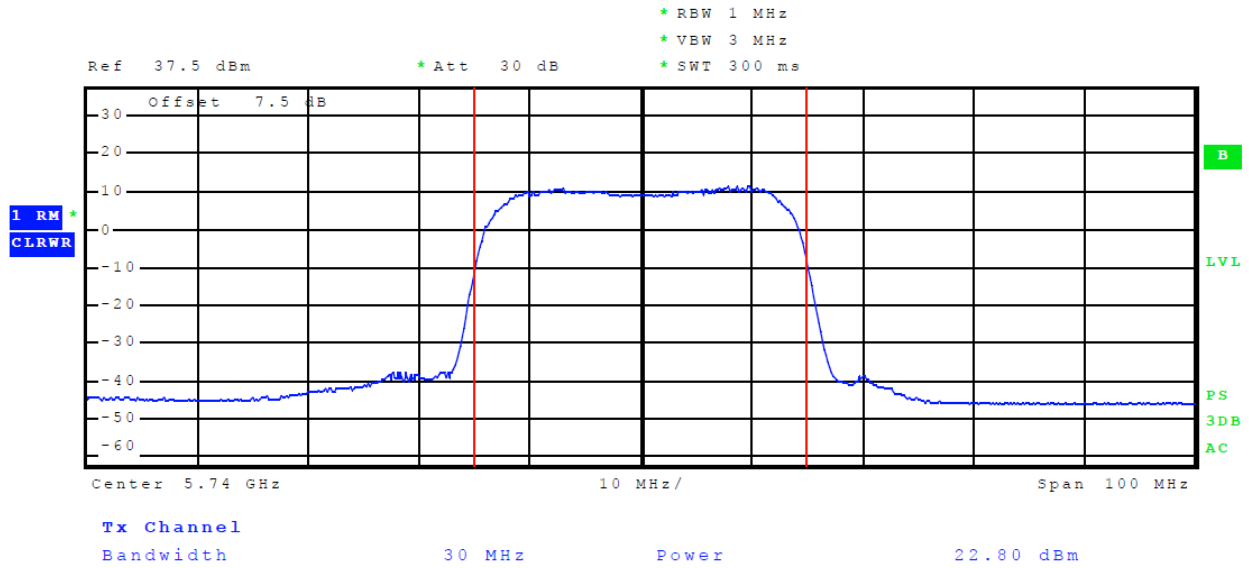

Figure 9 Plot of Antenna Port Power (30 MHz Channel, 64QAM)

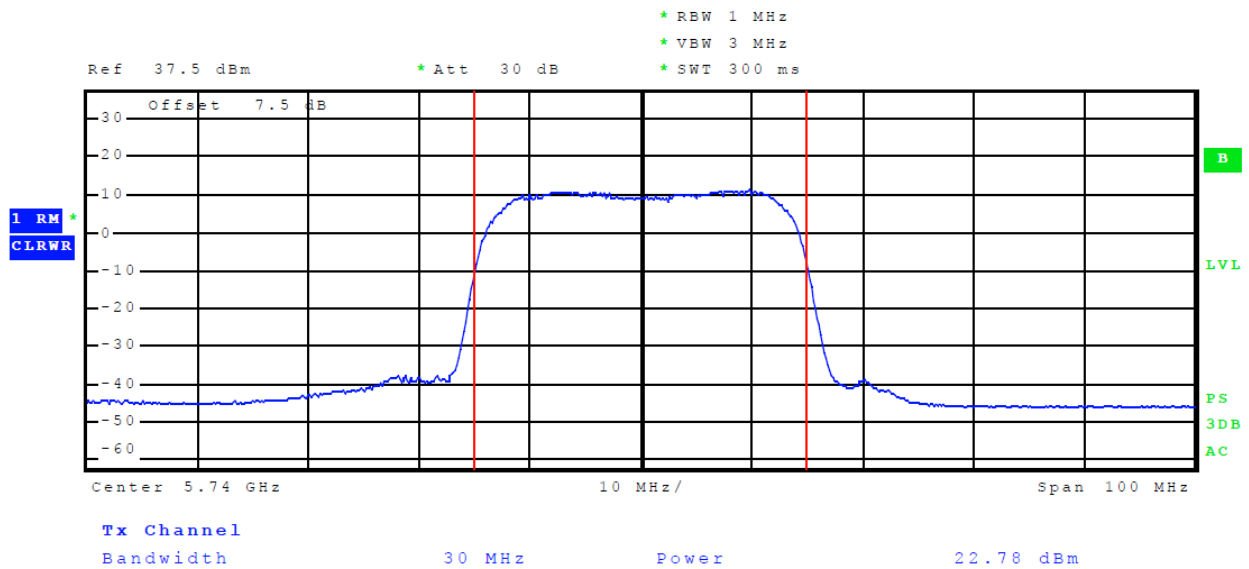

Figure 10 Plot of Antenna Port Power (30 MHz Channel, 128QAM)

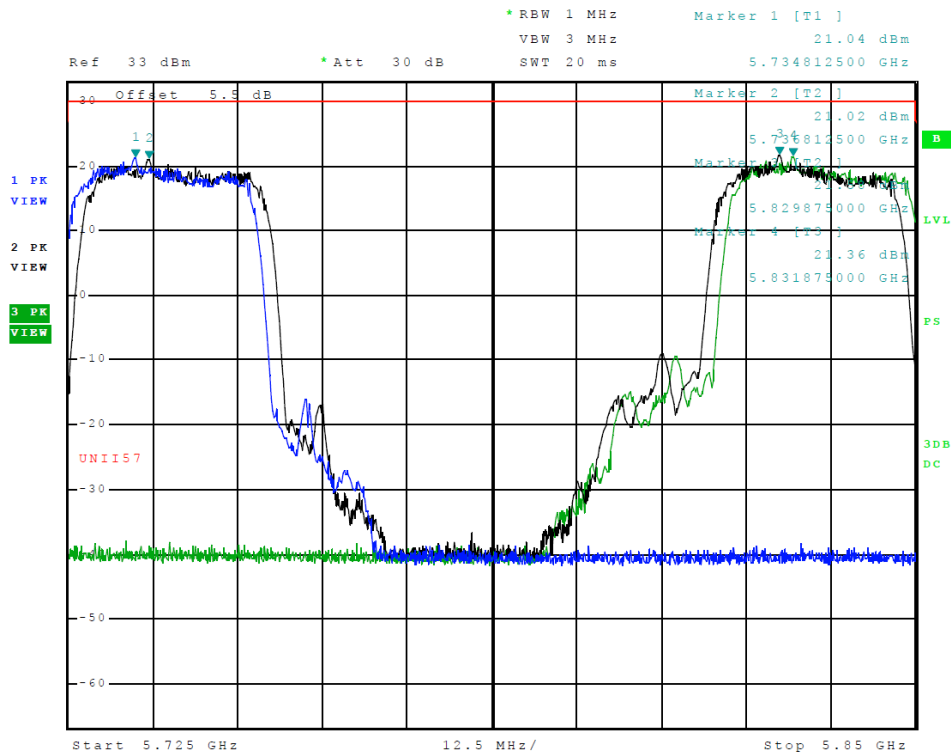

Figure 11 Plot of Transmitter Operation Across 5725-5850 MHz Band (28 MHz Channel)

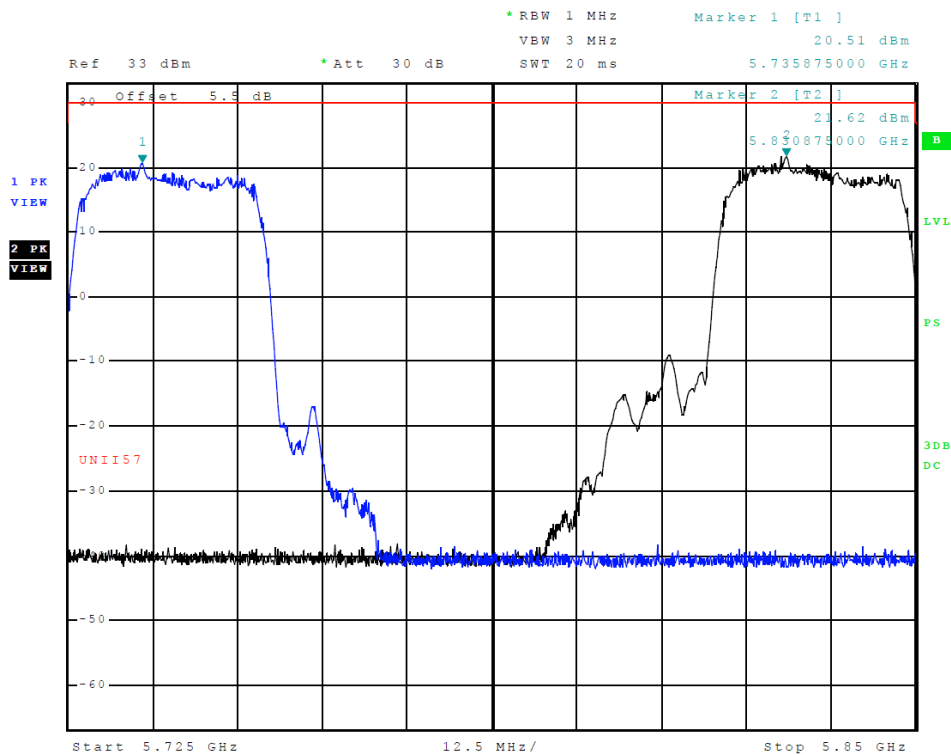

Figure 12 Plot of Transmitter Operation Across 5725-5850 MHz Band (30 MHz Channel)

TEST #2 Maximum power spectral density 15.407(a)(3)

Measurement of maximum power spectral density in any 500-kHz band. Testing was performed as directed in KDB 789033 D02 General UNII Test Procedures New Rules v01r04 for peak power spectral density.

Methods of Measurement power spectral density

789033 D02 General UNII Test Procedures New Rules v01r04

F. Maximum Power Spectral Density (PSD)

The rules requires “maximum power spectral density” measurements where the intent is to measure the maximum value of the time average of the power spectral density measured during a period of continuous transmission.

1. Create an average power spectrum for the EUT operating mode being tested by following the instructions in II.E.2. for measuring maximum conducted output power using a spectrum analyzer or EMI receiver: select the appropriate test method (SA-1, SA-2, SA-3, or alternatives to each) and apply it up to, but not including, the step labeled, “Compute power...” (This procedure is required even if the maximum conducted output power measurement was performed using a power meter, method PM.)

2. Use the peak search function on the instrument to find the peak of the spectrum and record its value.

3. Make the following adjustments to the peak value of the spectrum, if applicable:

a) If Method SA-2 or SA-2 Alternative was used, add $10 \log(1/x)$, where x is the duty cycle, to the peak of the spectrum.

b) If Method SA-3 Alternative was used and the linear mode was used in step II.E.2.g)(viii), add 1 dB to the final result to compensate for the difference between linear averaging and power averaging.

4. The result is the Maximum PSD over 1 MHz reference bandwidth.

5. For devices operating in the bands 5.15–5.25 GHz, 5.25–5.35 GHz, and 5.47–5.725 GHz, the above procedures make use of 1 MHz RBW to satisfy directly the 1 MHz reference bandwidth specified in Section 15.407(a)(5). For devices operating in the band 5.725–5.85 GHz, the rules specify a measurement bandwidth of 500 kHz. Many spectrum analyzers do not have 500 kHz RBW, thus a narrower RBW may need to be used. The rules permit the use of a RBWs less than 1 MHz, or 500 kHz, “provided that the measured power is integrated over the full reference bandwidth” to show the total power over the specified measurement bandwidth (i.e., 1 MHz, or 500 kHz). If measurements are performed using a reduced resolution bandwidth (< 1 MHz, or 500 kHz) and integrated over 1 MHz, or 500 kHz bandwidth, the following adjustments to the procedures apply:

a) Set $RBW \geq 1/T$, where T is defined in II.B.1.a).

b) Set $VBW \geq 3 RBW$.

c) If measurement bandwidth of Maximum PSD is specified in 500 kHz, add $10 \log(500 \text{ kHz}/RBW)$ to the measured result, whereas $RBW (< 500 \text{ kHz})$ is the reduced resolution bandwidth of the spectrum analyzer set during measurement.

d) If measurement bandwidth of Maximum PSD is specified in 1 MHz, add $10 \log(1\text{MHz}/RBW)$ to the measured result, whereas $RBW (< 1 \text{ MHz})$ is the reduced resolution bandwidth of spectrum analyzer set during measurement.

e) Care must be taken to ensure that the measurements are performed during a period of continuous transmission or are corrected upward for duty cycle.

Note: As a practical matter, it is recommended to use reduced RBW of 100 kHz for steps 5.c) and 5.d) above, since $RBW=100 \text{ KHZ}$ is available on nearly all spectrum analyzers.

Test Arrangement power spectral density

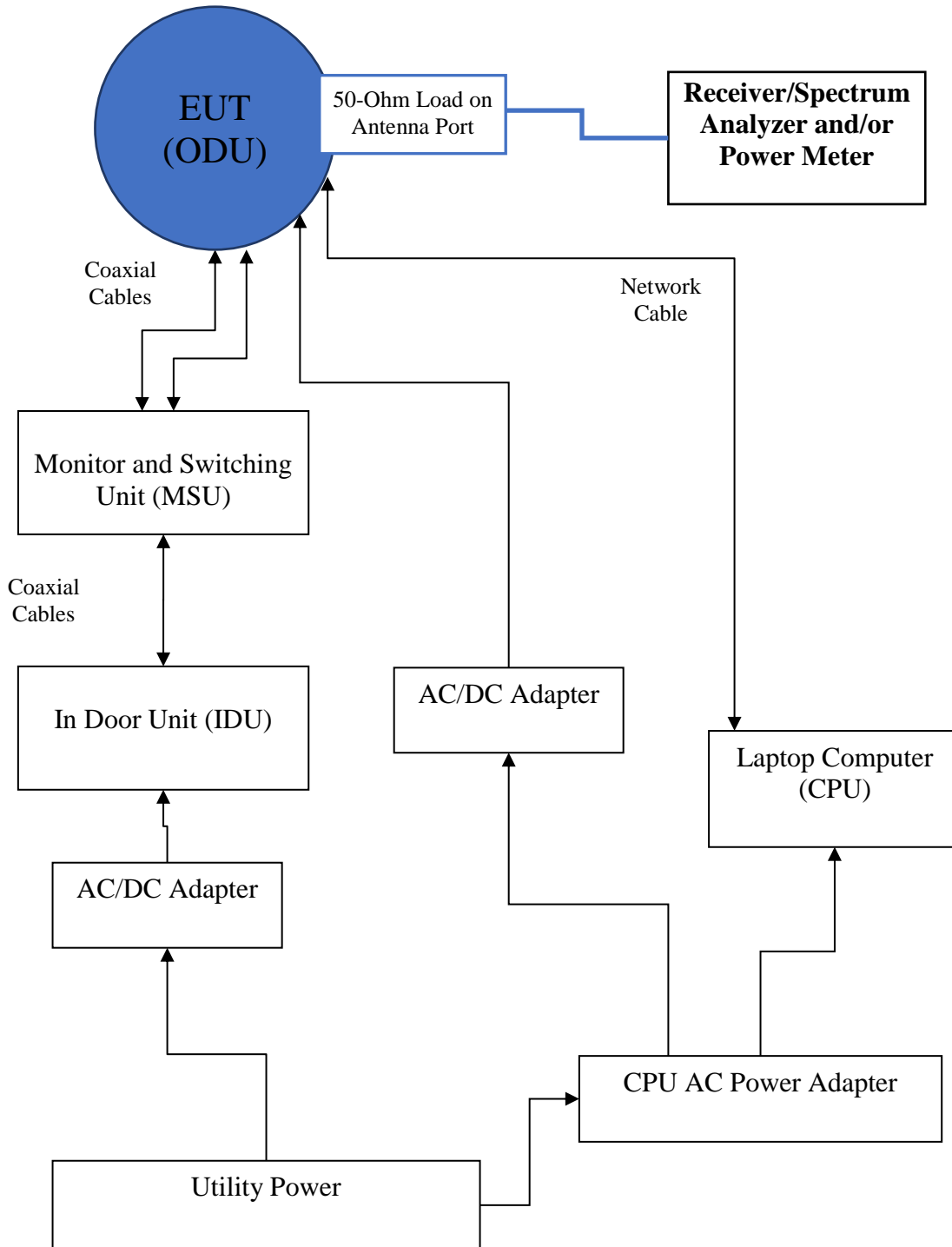

§15.407(a)(3) General technical requirements

(a) *Power limits:*

(3) For the band 5.725-5.85 GHz, the maximum conducted output power over the frequency band of operation shall not exceed 1 W. In addition, the maximum power spectral density shall not exceed 30 dBm in any 500-kHz band. If transmitting antennas of directional gain greater than 6 dBi are used, both the maximum conducted output power and the maximum power spectral density shall be reduced by the amount in dB that the directional gain of the antenna exceeds 6 dBi. However, fixed point-to-point U-NII devices operating in this band may employ transmitting antennas with directional gain greater than 6 dBi without any corresponding reduction in transmitter conducted power. Fixed, point-to-point operations exclude the use of point-to-multipoint systems, omnidirectional applications, and multiple collocated transmitters transmitting the same information. The operator of the U-NII device, or if the equipment is professionally installed, the installer, is responsible for ensuring that systems employing high gain directional antennas are used exclusively for fixed, point-to-point operations.

Table 2 Maximum power spectral density data

Frequency MHz	Peak Power Spectral Density (dBm)
28 MHz Channel (4QAM)	
5739.0	21.94 dBm/500kHz
5834.0	20.95 dBm/500kHz
5836.0	20.93 dBm/500kHz
28 MHz Channel (16QAM)	
5739.0	21.25 dBm/500kHz
5834.0	21.54 dBm/500kHz
5836.0	21.42 dBm/500kHz
28 MHz Channel (32QAM)	
5739.0	20.36 dBm/500kHz
5834.0	20.48 dBm/500kHz
5836.0	20.79 dBm/500kHz
28 MHz Channel (64QAM)	
5739.0	18.50 dBm/500kHz
5834.0	18.11 dBm/500kHz
5836.0	18.61 dBm/500kHz
28 MHz Channel (128QAM)	
5739.0	18.51 dBm/500kHz
5834.0	18.01 dBm/500kHz
5836.0	18.61 dBm/500kHz
30 MHz Channel (4QAM)	
5740.0	22.02 dBm/500kHz
5835.0	21.53 dBm/500kHz
30 MHz Channel (16QAM)	
5740.0	21.51 dBm/500kHz
5835.0	21.27 dBm/500kHz
30 MHz Channel (32QAM)	
5740.0	20.45 dBm/500kHz
5835.0	21.18 dBm/500kHz
30 MHz Channel (64QAM)	
5740.0	18.73 dBm/500kHz
5835.0	19.14 dBm/500kHz
30 MHz Channel (128QAM)	
5740.0	18.59 dBm/500kHz
5835.0	19.12 dBm/500kHz

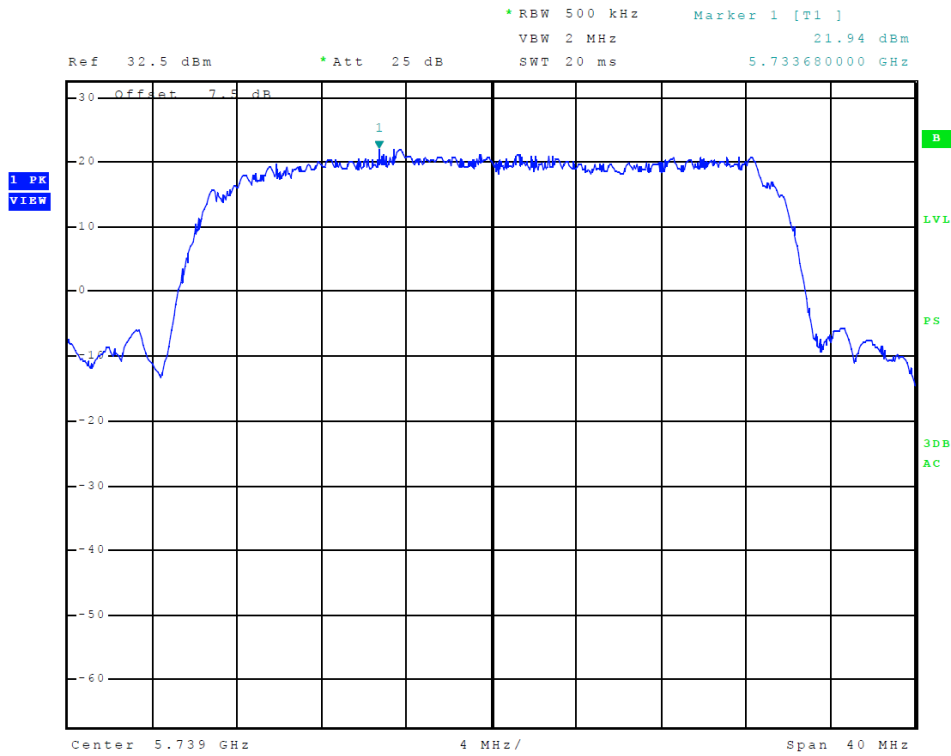

Figure 13 Plot of Power Spectral Density (28 MHz Channel 4QAM)

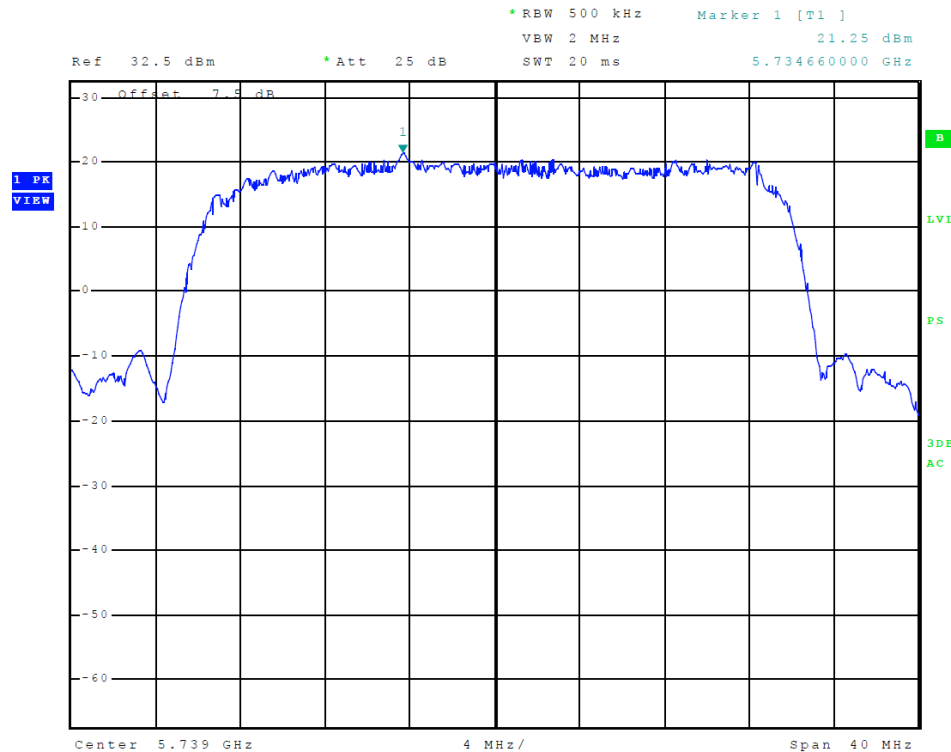

Figure 14 Plot of Power Spectral Density (28 MHz Channel 16QAM)

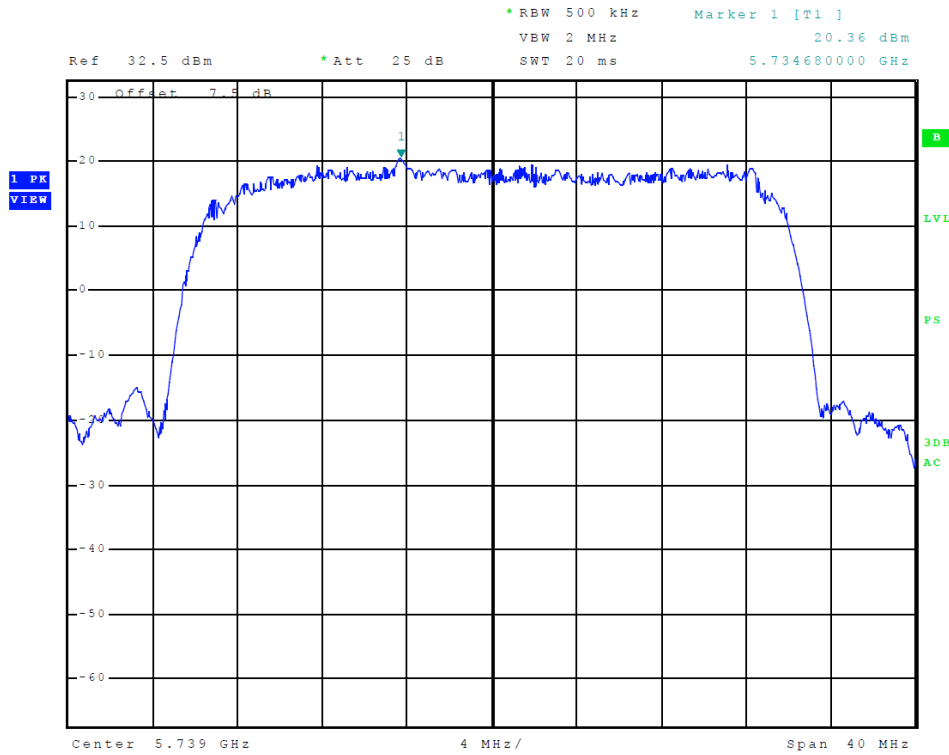

Figure 15 Plot of Power Spectral Density (28 MHz Channel 32QAM)

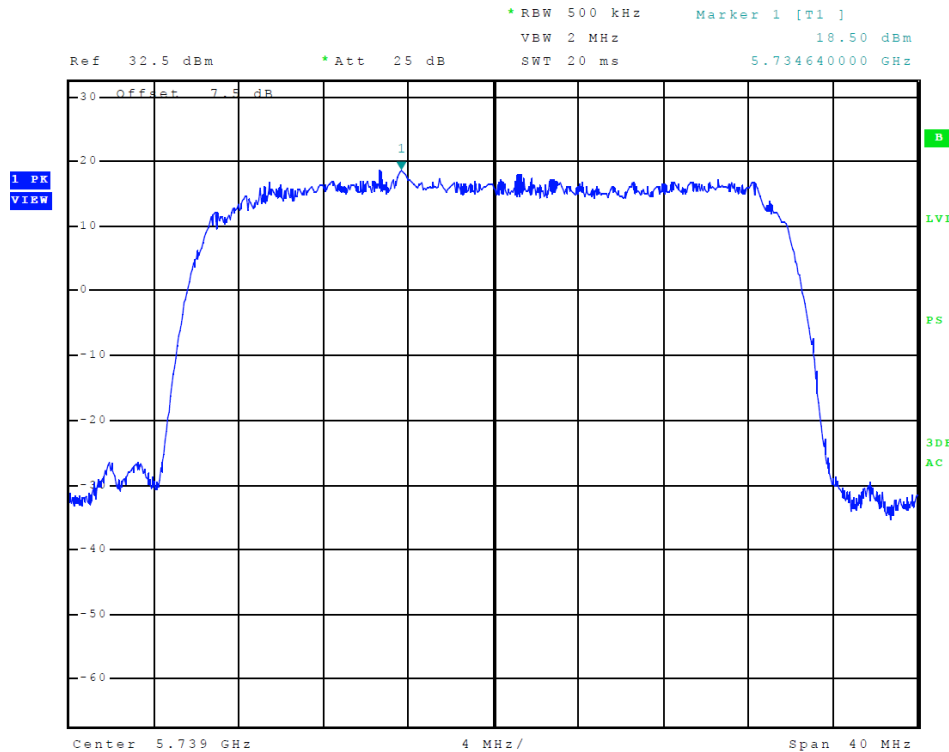

Figure 16 Plot of Power Spectral Density (28 MHz Channel 64QAM)

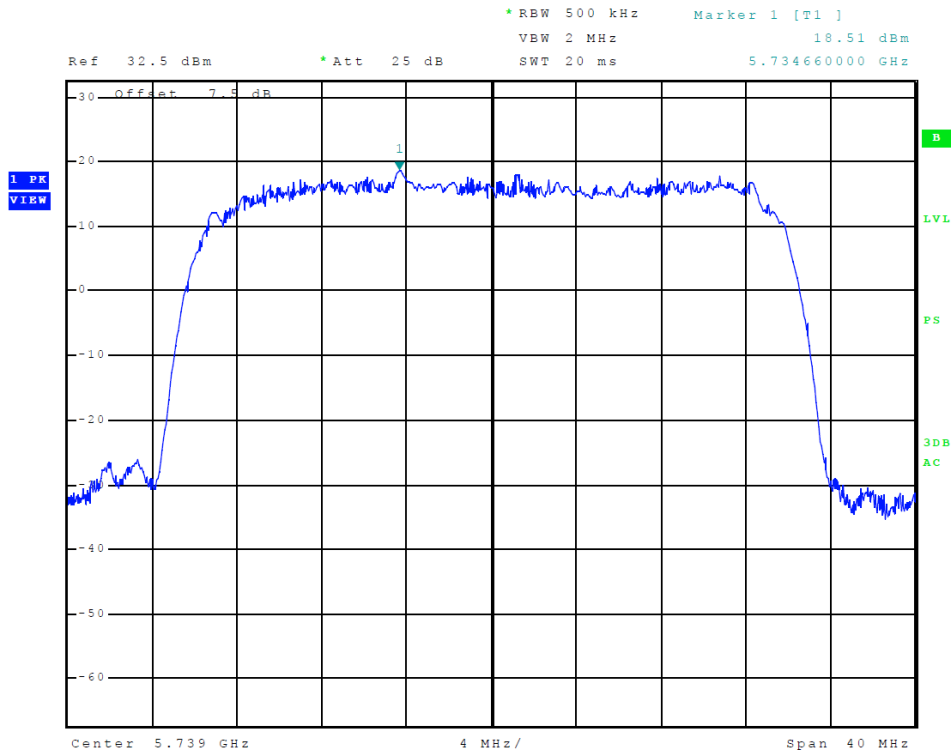

Figure 17 Plot of Power Spectral Density (28 MHz Channel 128QAM)

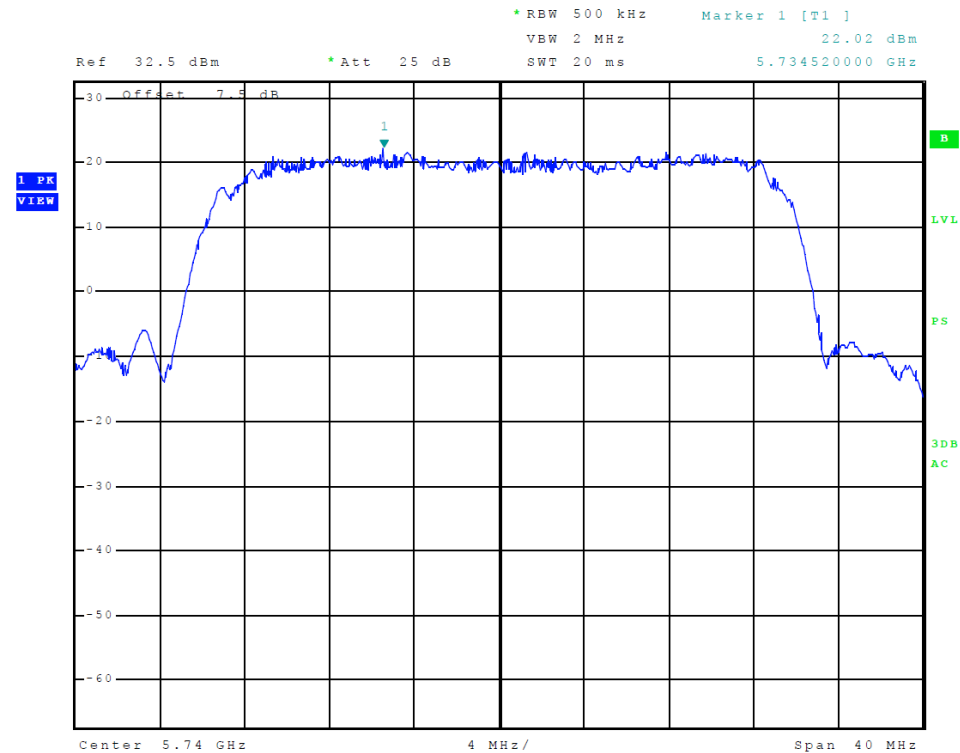

Figure 18 Plot of Power Spectral Density (30 MHz Channel 4QAM)

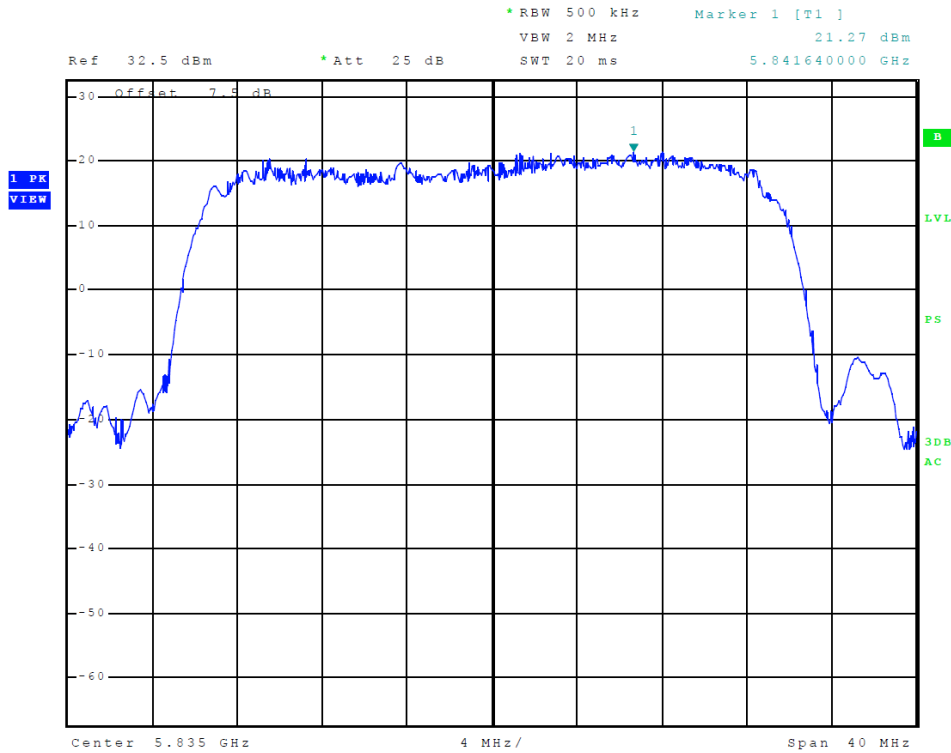

Figure 19 Plot of Power Spectral Density (30 MHz Channel 16QAM)

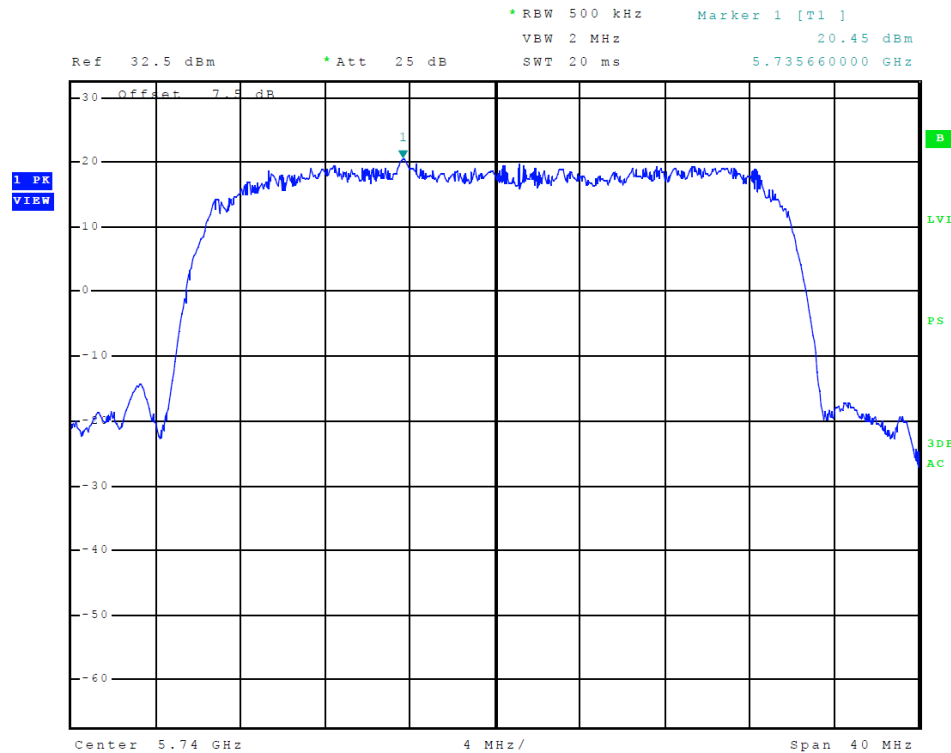

Figure 20 Plot of Power Spectral Density (30 MHz Channel 32QAM)

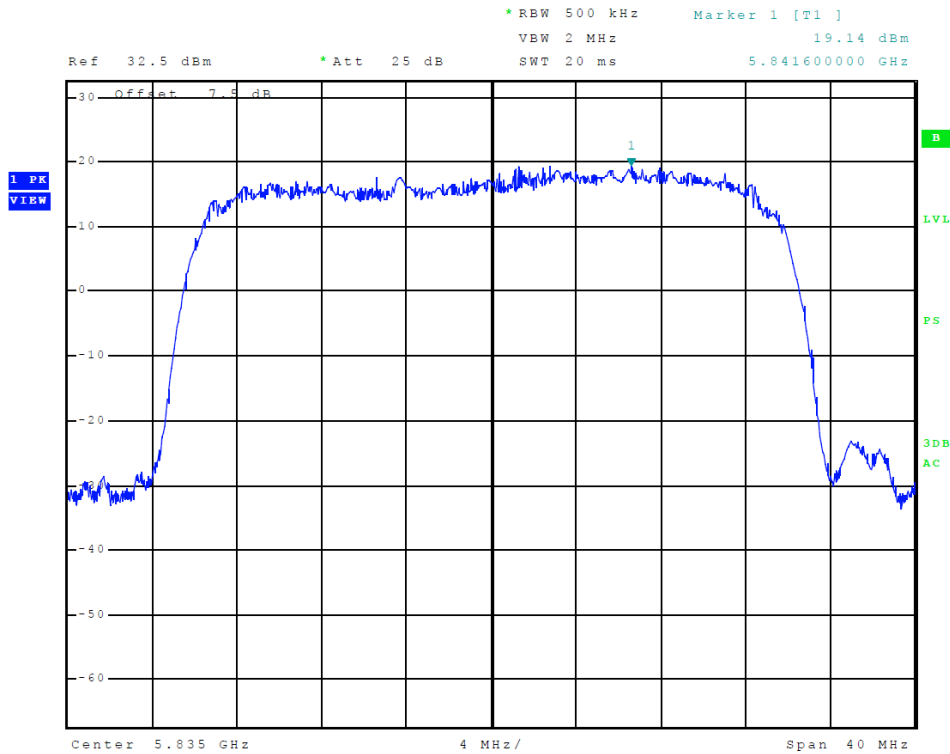

Figure 21 Plot of Power Spectral Density (30 MHz Channel 64QAM)

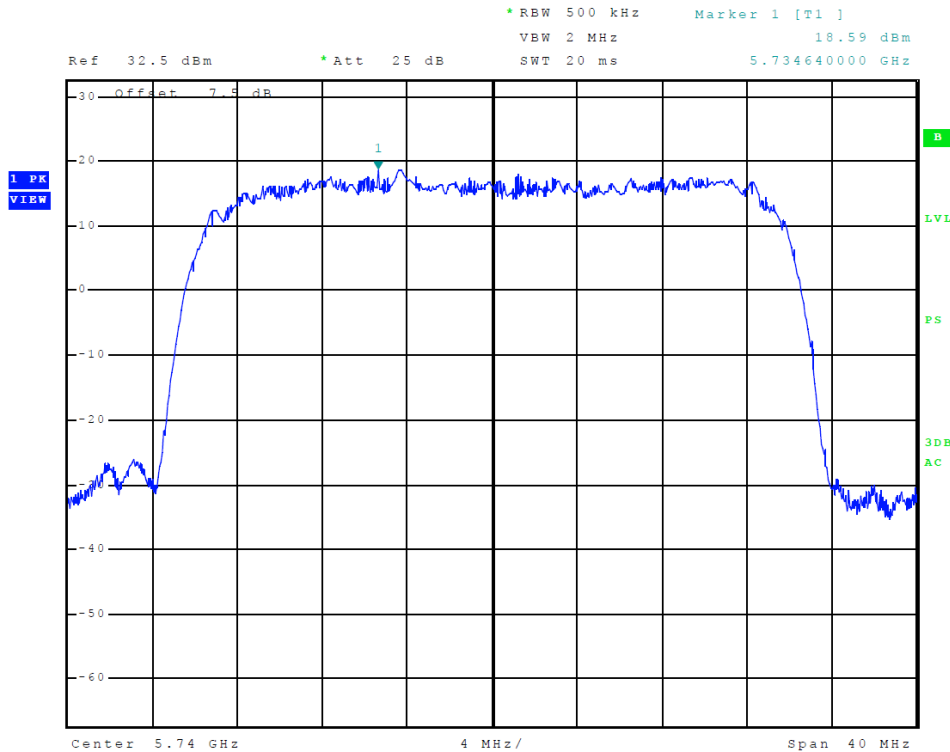

Figure 22 Plot of Power Spectral Density (30 MHz Channel 128QAM)

TEST #3 Undesirable emissions 15.407(b)(4) Conducted

The undesirable emissions from an intentional radiator shall not exceed the field strength levels specified. Emissions testing as performed at the antenna port and investigation made using all available modulations. Change in modulation had no impact on emission spectral profile. Antenna Port Conducted emission testing was performed in a screen room.

Conducted emissions testing was performed as directed in 789033 D02 General UNII Test Procedures New Rules v01r04. Worst-case emissions are documented in this report.

Methods of Measurement Undesirable emissions

G. Unwanted Emission Measurement

Note: Sections 1. and 2. below cover measurements in the restricted and non-restricted bands, respectively. However, those sections are not self-contained. Rather, they reference the general unwanted emissions measurement requirements in Section 3. and the specific measurement procedures in Sections 4., 5., and 6.

2. Unwanted Emissions that fall Outside of the Restricted Bands

a) For all measurements, follow the requirements in II.G.3. *“General Requirements for Unwanted Emissions Measurements.”*

b) At frequencies below 1000 MHz, use the procedure described in II.G.4. *“Procedure for Unwanted Emissions Measurements Below 1000 MHz.”*

c) At frequencies above 1000 MHz, use the procedure for maximum emissions described in II.G.5., *“Procedure for Unwanted Emissions Measurements Above 1000 MHz.”*

(i) Sections 15.407(b)(1) to (b)(3) specify the unwanted emission limits for the U-NII-1 and U-NII-2 bands. As specified, emissions above 1000 MHz that are outside of the restricted bands are subject to a peak emission limit of $\square 27$ dBm/MHz.³

(ii) Section 15.407(b)(4) specifies the unwanted emission limit for the U-NII-3 band. A band emissions mask is specified in Section 15.407(b)(4)(i). The emission limits are in terms of a Peak detector. An alternative to the band emissions mask is specified in Section 15.407(b)(4)(ii). The alternative limits are based on the highest antenna gain specified in the filing. There are also marketing and importation restrictions for the devices using the alternative limit.⁴

d) If *radiated* measurements are performed, field strength is then converted to EIRP as follows:

(i) $EIRP = ((E \times d)^2) / 30$

where:

- E is the field strength in V/m;
- d is the measurement distance in meters;
- EIRP is the equivalent isotropically radiated power in watts.

(ii) Working in dB units, the above equation is equivalent to:

$$EIRP[dBm] = E[dB\mu V/m] + 20 \log(d[meters]) - 104.77$$

(iii) Or, if d is 3 meters:

$$EIRP[dBm] = E[dB\mu V/m] - 95.2$$

The EUT was arranged as diagramed below and operated through all available modulation modes with worst-case data recorded. The frequency spectrum from 9 kHz to 60,000 MHz was searched for undesirable emissions.

Test Arrangement antenna port conducted Undesirable emissions

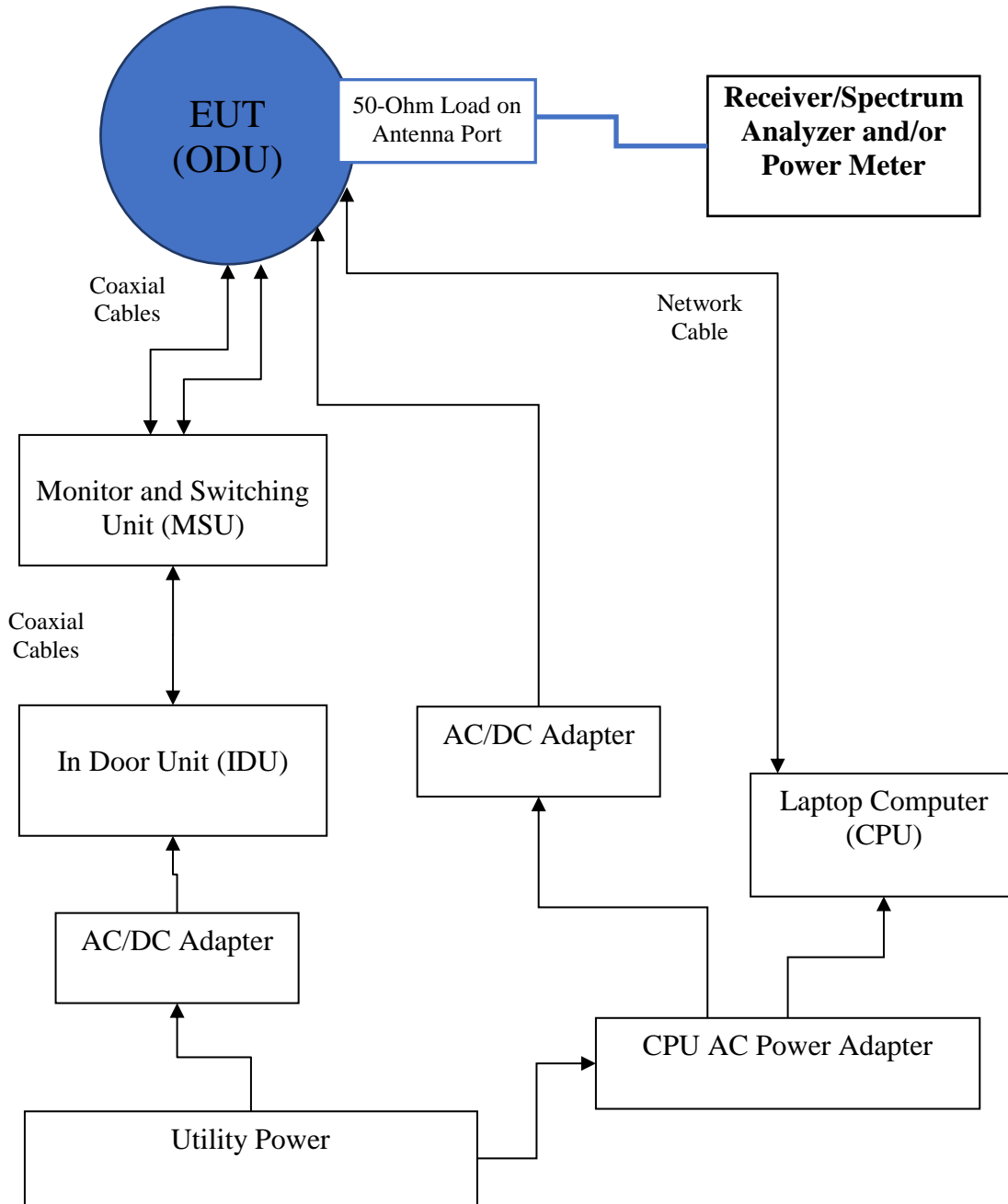

§15.407(b)(4) Undesirable emission limits

(b) *Undesirable emission limits.* Except as shown in paragraph (b)(7) of this section, the maximum emissions outside of the frequency bands of operation shall be attenuated in accordance with the following limits:

(4) For transmitters operating in the 5.725-5.85 GHz band:

(i) All emissions shall be limited to a level of -27 dBm/MHz at 75 MHz or more above or below the band edge increasing linearly to 10 dBm/MHz at 25 MHz above or below the band edge, and from 25 MHz above or below the band edge increasing linearly to a level of 15.6 dBm/MHz at 5 MHz above or below the band edge, and from 5 MHz above or below the band edge increasing linearly to a level of 27 dBm/MHz at the band edge.

(ii) Devices certified before March 2, 2017 with antenna gain greater than 10 dBi may demonstrate compliance with the emission limits in §15.247(d), but manufacturing, marketing and importing of devices certified under this alternative must cease by March 2, 2018. Devices certified before March 2, 2018 with antenna gain of 10 dBi or less may demonstrate compliance with the emission limits in §15.247(d), but manufacturing, marketing and importing of devices certified under this alternative must cease before March 2, 2020.

(5) The emission measurements shall be performed using a minimum resolution bandwidth of 1 MHz. A lower resolution bandwidth may be employed near the band edge, when necessary, provided the measured energy is integrated to show the total power over 1 MHz.

(6) Unwanted emissions below 1 GHz must comply with the general field strength limits set forth in §15.209. Further, any U-NII devices using an AC power line are required to comply also with the conducted limits set forth in §15.207.

(7) The provisions of §15.205 apply to intentional radiators operating under this section.

(8) When measuring the emission limits, the nominal carrier frequency shall be adjusted as close to the upper and lower frequency band edges as the design of the equipment permits.

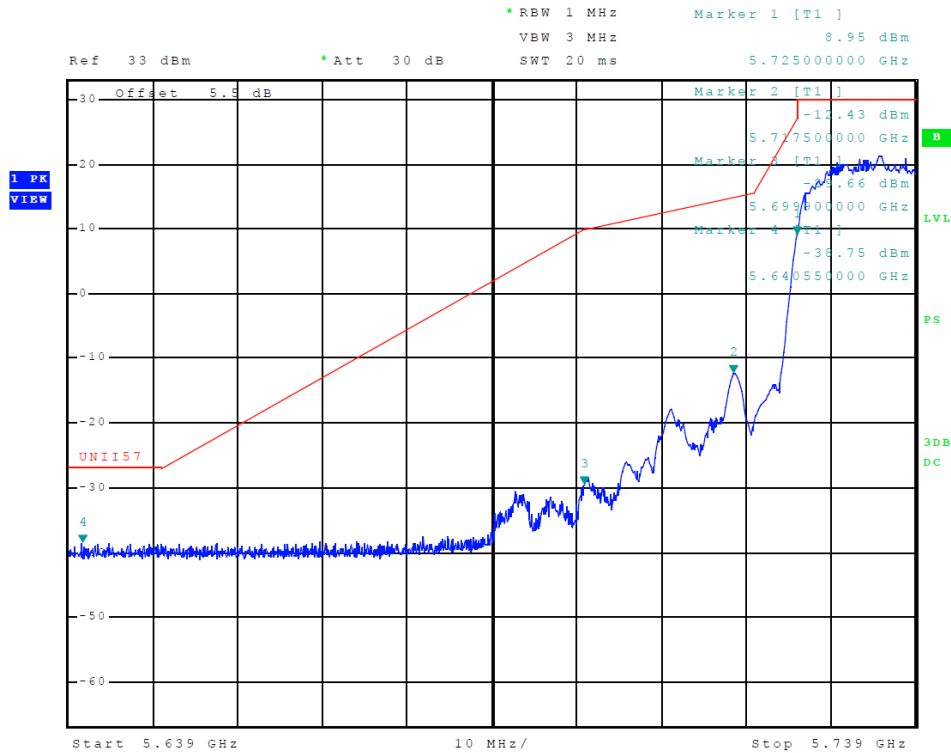

Figure 23 Plot of Undesirable emissions (28 MHz Channel)

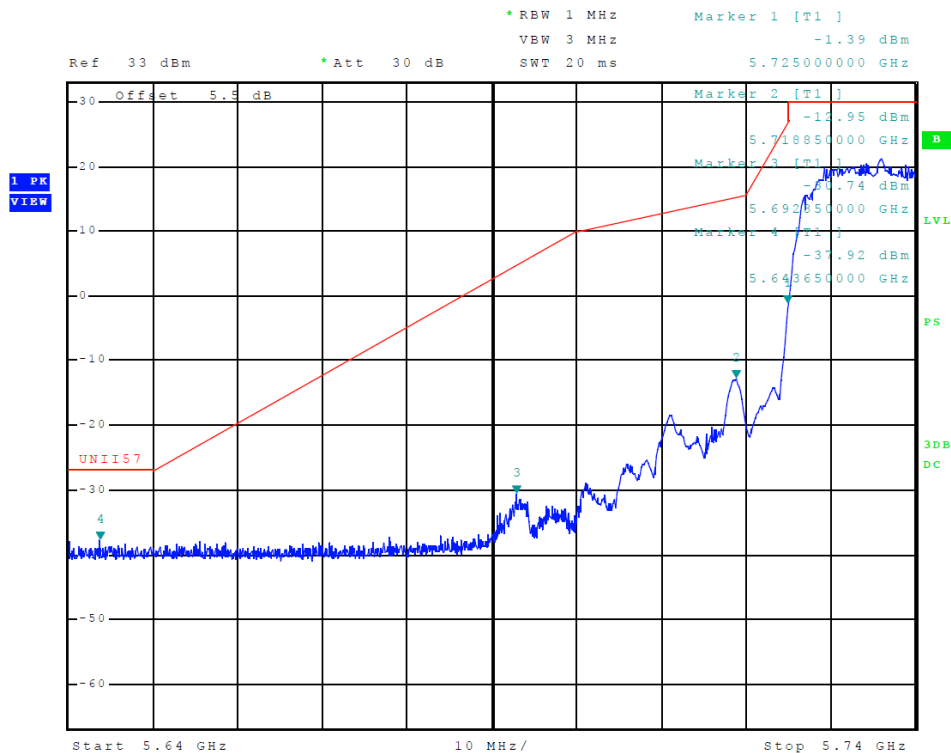

Figure 24 Plot of Undesirable emissions (30 MHz Channel)

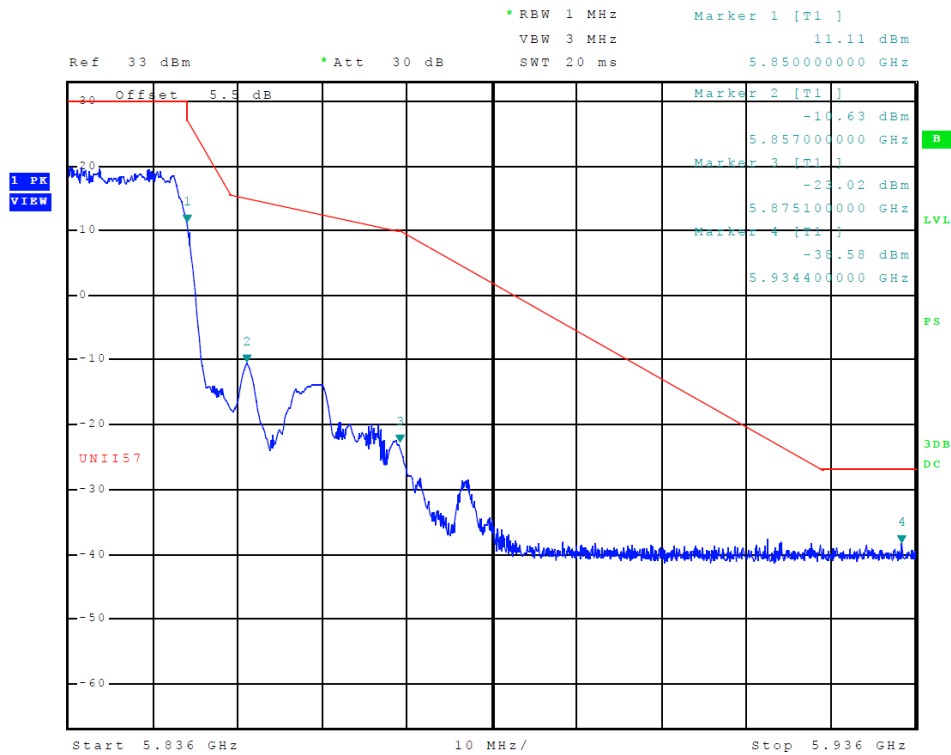

Figure 25 Plot of Undesirable emissions (328 MHz Channel)

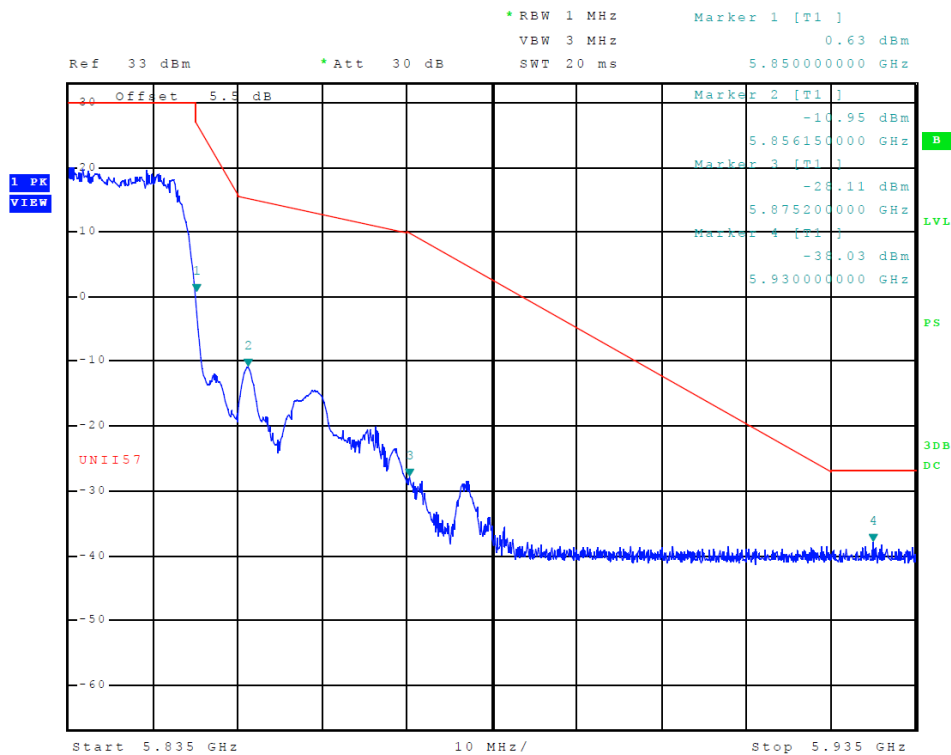

Figure 26 Plot of Undesirable emissions (30 MHz Channel)

TEST #4 Undesirable emissions 15.407(b)(4) Radiated

The undesirable emissions from an intentional radiator shall not exceed the field strength levels specified. Emissions testing as performed at the antenna port and investigation made using all available modulations. Change in modulation had no impact on emission spectral profile. Radiated emission testing was performed on the OATS measuring radiated emissions as required. Radiated emissions testing was performed as directed in 789033 D02 General UNII Test Procedures New Rules v01r04. Worst-case emissions are documented in this report.

Methods of Measurement Undesirable emissions

G. Unwanted Emission Measurement

Note: Sections 1. and 2. below cover measurements in the restricted and non-restricted bands, respectively. However, those sections are not self-contained. Rather, they reference the general unwanted emissions measurement requirements in Section 3. and the specific measurement procedures in Sections 4., 5., and 6.

2. Unwanted Emissions that fall Outside of the Restricted Bands

a) For all measurements, follow the requirements in II.G.3. *“General Requirements for Unwanted Emissions Measurements.”*

b) At frequencies below 1000 MHz, use the procedure described in II.G.4. *“Procedure for Unwanted Emissions Measurements Below 1000 MHz.”*

c) At frequencies above 1000 MHz, use the procedure for maximum emissions described in II.G.5., *“Procedure for Unwanted Emissions Measurements Above 1000 MHz.”*

(i) Sections 15.407(b)(1) to (b)(3) specify the unwanted emission limits for the U-NII-1 and U-NII-2 bands. As specified, emissions above 1000 MHz that are outside of the restricted bands are subject to a peak emission limit of ≤ 27 dBm/MHz.³

(ii) Section 15.407(b)(4) specifies the unwanted emission limit for the U-NII-3 band. A band emissions mask is specified in Section 15.407(b)(4)(i). The emission limits are in terms of a Peak detector. An alternative to the band emissions mask is specified in Section 15.407(b)(4)(ii). The alternative limits are based on the highest antenna gain specified in the filing. There are also marketing and importation restrictions for the devices using the alternative limit.⁴

d) If *radiated* measurements are performed, field strength is then converted to EIRP as follows:

(i) $EIRP = ((E \times d)^2) / 30$

where:

- E is the field strength in V/m;
- d is the measurement distance in meters;
- EIRP is the equivalent isotropically radiated power in watts.

(ii) Working in dB units, the above equation is equivalent to:

$$\text{EIRP[dBm]} = \text{E[dB}\mu\text{V/m]} + 20 \log (d[\text{meters}]) - 104.77$$

(iii) Or, if d is 3 meters:

$$\text{EIRP[dBm]} = \text{E[dB}\mu\text{V/m]} - 95.2$$

The EUT was arranged in a typical equipment configuration and operated through all available modulation modes with worst-case data recorded. Preliminary testing was performed in a screen room with the EUT positioned 1 meter from the FSM. Radiated emissions measurements were performed to identify the frequencies, which produced the highest emissions. Each radiated emission investigated was then maximized at the OATS location before final radiated emission measurements performed. Final data was taken with the EUT located at the OATS at a distance of 3 meters between the EUT and the receiving antenna. The frequency spectrum from 9 kHz to 60,000 MHz was searched for general radiated emissions. Measured emission levels were maximized by EUT placement on the table, rotating the turntable through 360 degrees, varying the antenna height between 1 and 4 meters above the ground plane and changing antenna position between horizontal and vertical polarization. Antennas used were Loop from 9 kHz to 30 MHz, Broadband Biconical from 30 to 200 MHz, Biconilog from 30 to 1000 MHz, Log Periodic from 200 MHz to 1 GHz and or Double Ridge or pyramidal horns and mixers above 1 GHz, notch filters, and appropriate amplifiers and external mixers were utilized.

Test Arrangement Radiated Undesirable emissions

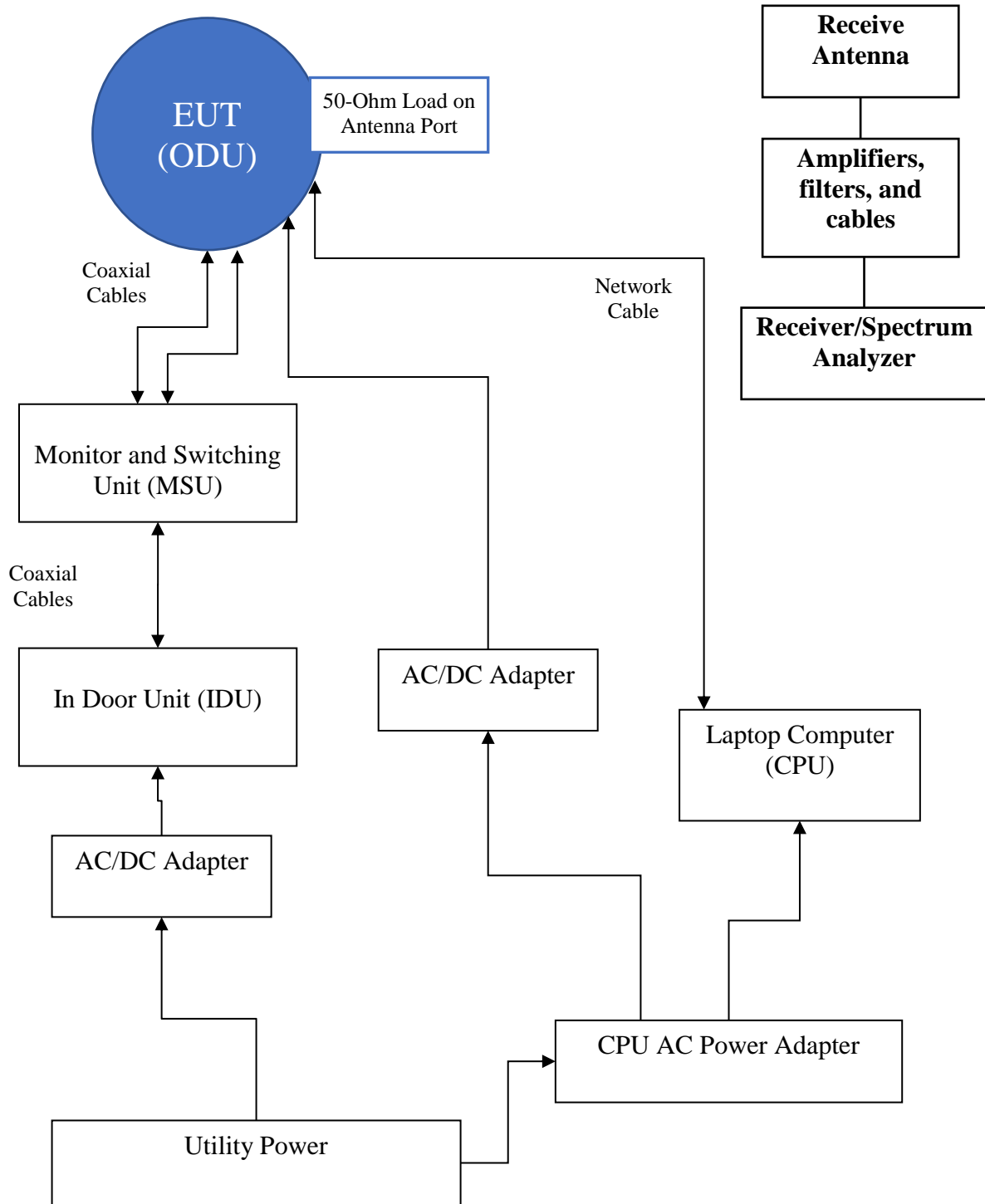

§15.407(b)(4) Undesirable emission limits

(b) *Undesirable emission limits.* Except as shown in paragraph (b)(7) of this section, the maximum emissions outside of the frequency bands of operation shall be attenuated in accordance with the following limits:

(4) For transmitters operating in the 5.725-5.85 GHz band:

(i) All emissions shall be limited to a level of -27 dBm/MHz at 75 MHz or more above or below the band edge increasing linearly to 10 dBm/MHz at 25 MHz above or below the band edge, and from 25 MHz above or below the band edge increasing linearly to a level of 15.6 dBm/MHz at 5 MHz above or below the band edge, and from 5 MHz above or below the band edge increasing linearly to a level of 27 dBm/MHz at the band edge.

(ii) Devices certified before March 2, 2017 with antenna gain greater than 10 dBi may demonstrate compliance with the emission limits in §15.247(d), but manufacturing, marketing and importing of devices certified under this alternative must cease by March 2, 2018. Devices certified before March 2, 2018 with antenna gain of 10 dBi or less may demonstrate compliance with the emission limits in §15.247(d), but manufacturing, marketing and importing of devices certified under this alternative must cease before March 2, 2020.

(5) The emission measurements shall be performed using a minimum resolution bandwidth of 1 MHz. A lower resolution bandwidth may be employed near the band edge, when necessary, provided the measured energy is integrated to show the total power over 1 MHz.

(6) Unwanted emissions below 1 GHz must comply with the general field strength limits set forth in §15.209. Further, any U-NII devices using an AC power line are required to comply also with the conducted limits set forth in §15.207.

(7) The provisions of §15.205 apply to intentional radiators operating under this section.

(8) When measuring the emission limits, the nominal carrier frequency shall be adjusted as close to the upper and lower frequency band edges as the design of the equipment permits.

Table 3 Undesirable emissions, Radiated Data

Frequency in MHz	Horizontal Peak (dBµV/m)	Horizontal Average (dBµV/m)	Vertical Peak (dBµV/m)	Vertical Average (dBµV/m)	Limit @ 3m (dBµV/m)
5740.0	--	--	--	--	--
11480.0	50.5	38.0	50.7	37.9	68.3
17220.0	58.7	46.5	59.7	46.7	68.3
22960.0	52.3	39.1	51.7	38.5	68.3
28700.0	56.7	42.9	55.3	42.6	68.3
5834.0	--	--	--	--	--
11668.0	52.5	39.6	52.6	39.7	68.3
17502.0	58.3	44.9	57.5	44.2	68.3
23336.0	52.5	39.3	52.3	39.3	68.3
29170.0	56.2	43.6	57.0	43.6	68.3
5835.0	--	--	--	--	--
11670.0	52.4	39.6	52.1	39.6	68.3
17505.0	58.0	45.3	58.8	45.7	68.3
23340.0	52.0	39.4	52.3	39.4	68.3
29175.0	56.8	43.8	56.5	43.7	68.3
Band Edges					
5725.0	61.9	50.4	58.8	47.2	78.2
5850.0	62.1	49.3	57.1	44.1	78.2

Other emissions present had amplitudes at least 20 dB below the limit. Peak and Quasi-Peak amplitude emissions are recorded above for frequency range of 30-1000 MHz. Peak and Average amplitude emissions are recorded above for frequency range above 1000 MHz.

TEST #5 Minimum 6-dB Bandwidth 15.407(e)

The minimum 6 dB bandwidth of U-NII devices in the 5725-5850 MHz band shall be at least 500 kHz. Testing was performed as directed in KDB 789033 D02 General UNII Test Procedures New Rules v01r04 for 6-dB Occupied Bandwidth.

Methods of Measurement Minimum 6-dB Bandwidth

789033 D02 General UNII Test Procedures New Rules v01r04

C. Bandwidth Measurement

2. Minimum Emission Bandwidth for the band 5.725□5.85 GHz

Section 15.407(e) specifies the minimum 6 dB emission bandwidth of at least 500 kHz for the band 5.725□5.85 GHz. The following procedure shall be used for measuring this bandwidth:

- a) Set RBW = 100 kHz.
- b) Set the video bandwidth (VBW) $\geq 3 \square$ RBW.
- c) Detector = Peak.
- d) Trace mode = max hold.
- e) Sweep = auto couple.
- f) Allow the trace to stabilize.
- g) Measure the maximum width of the emission that is constrained by the frequencies associated with the two outermost amplitude points (upper and lower frequencies) that are attenuated by 6 dB relative to the maximum level measured in the fundamental emission.

Note: The automatic bandwidth measurement capability of a spectrum analyzer or EMI receiver may be employed if it implements the functionality described above.

Test Arrangement Minimum 6-dB Bandwidth

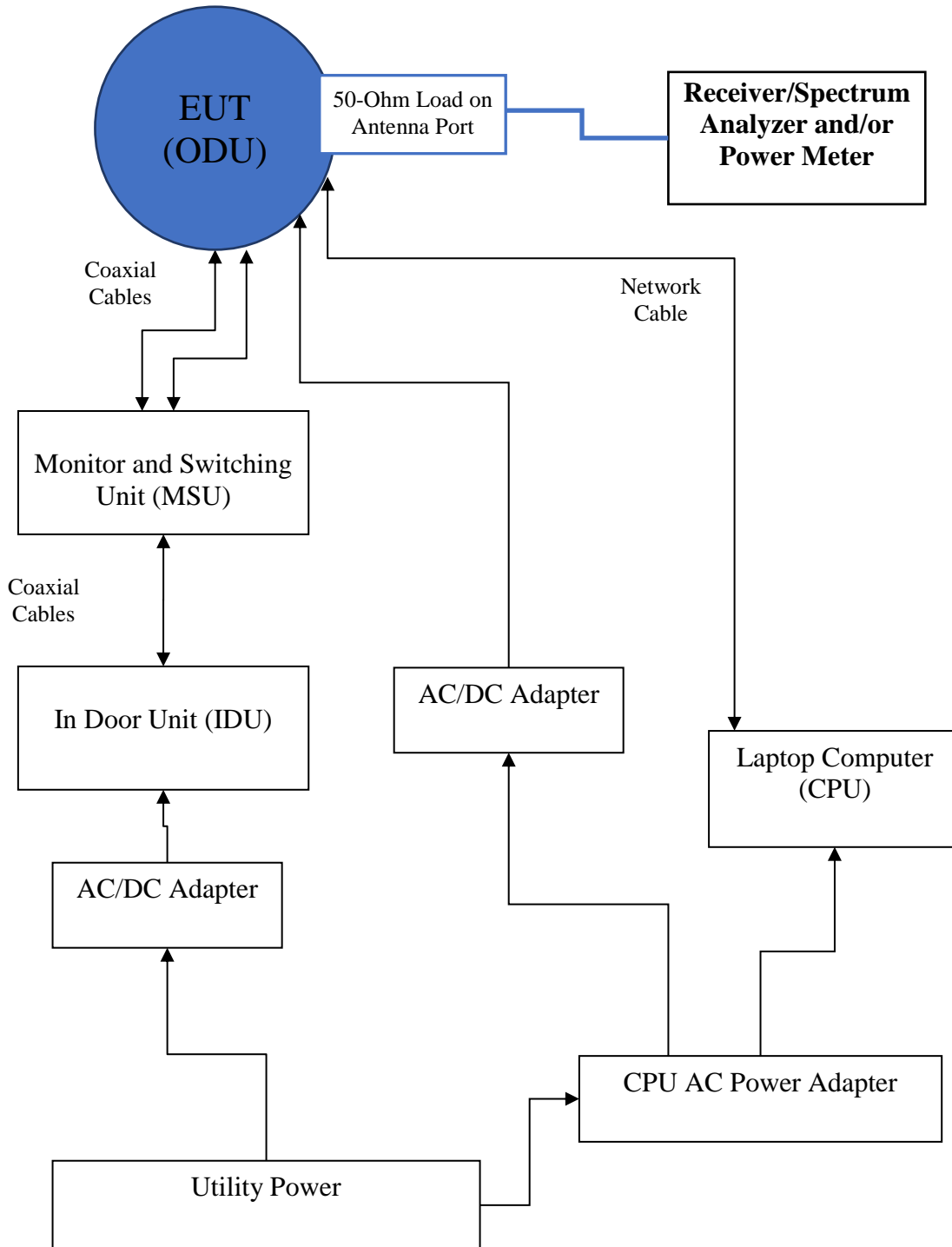

§15.407(e) General technical requirements

(e) Within the 5.725-5.85 GHz band, the minimum 6 dB bandwidth of U-NII devices shall be at least 500 kHz.

Table 4 Minimum 6-dB Bandwidth data

Frequency MHz	99% Occupied Bandwidth (kHz)	6-dB Bandwidth (kHz)	26-dB Bandwidth (kHz)
28 MHz Channel (4QAM)			
5739.0	27550	25450	29750
5834.0	27300	25400	29700
5836.0	27250	25100	29650
28 MHz Channel (16QAM)			
5739.0	27450	25900	29750
5834.0	27250	24750	29650
5836.0	27250	240200	29650
28 MHz Channel (32QAM)			
5739.0	27350	25250	29650
5834.0	27300	25400	29650
5836.0	27250	24650	29600
28 MHz Channel (64QAM)			
5739.0	27300	25600	29600
5834.0	27300	24850	29650
5836.0	27250	24700	29700
28 MHz Channel (128QAM)			
5739.0	27250	25400	29650
5834.0	27300	24350	29650
5836.0	27200	24350	29650
30 MHz Channel (4QAM)			
5740.0	27450	25300	29750
5835.0	27250	25000	29650
30 MHz Channel 16QAM)			
5740.0	27350	25400	29650
5835.0	27250	24700	29650
30 MHz Channel (32QAM)			
5740.0	27250	26200	29600
5835.0	27300	25050	29650
30 MHz Channel (64QAM)			
5740.0	27250	25150	29600
5835.0	27250	24750	29650
30 MHz Channel (128QAM)			
5740.0	27250	25100	29600
5835.0	27250	24450	29600

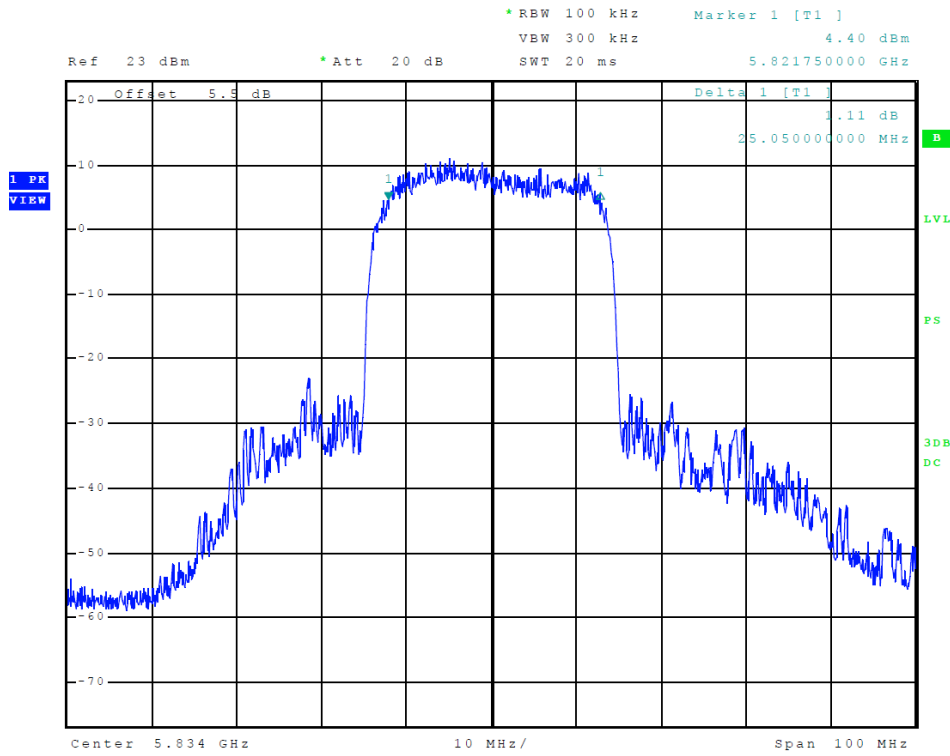

Figure 27 Plot of Minimum 6-dB Bandwidth (28 MHz Channel)

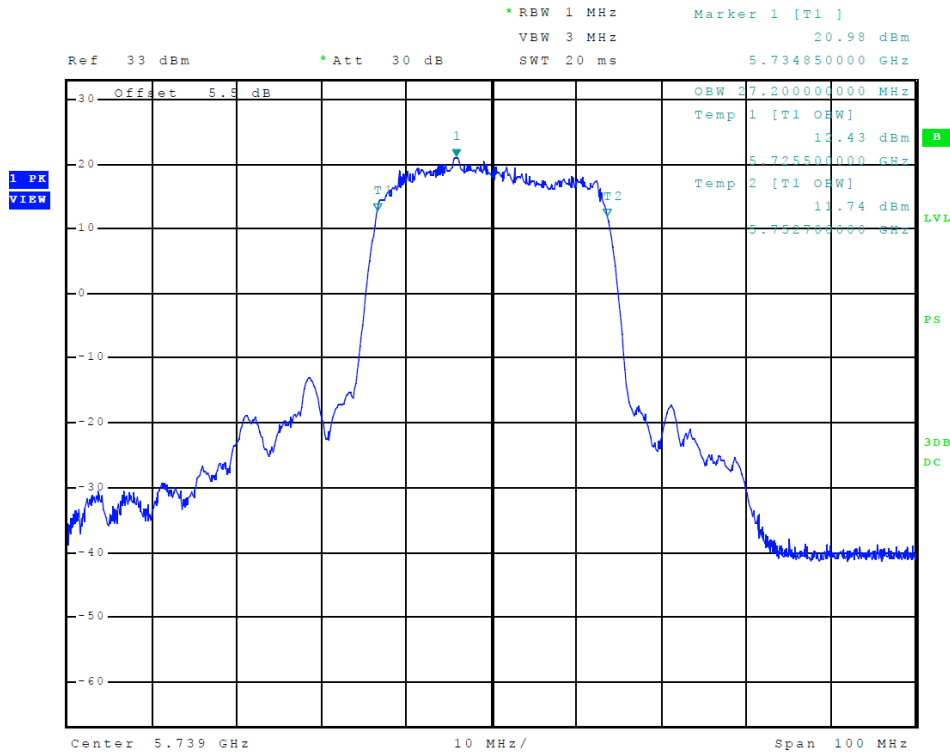

Figure 28 Plot of 99% OBW (28 MHz Channel)

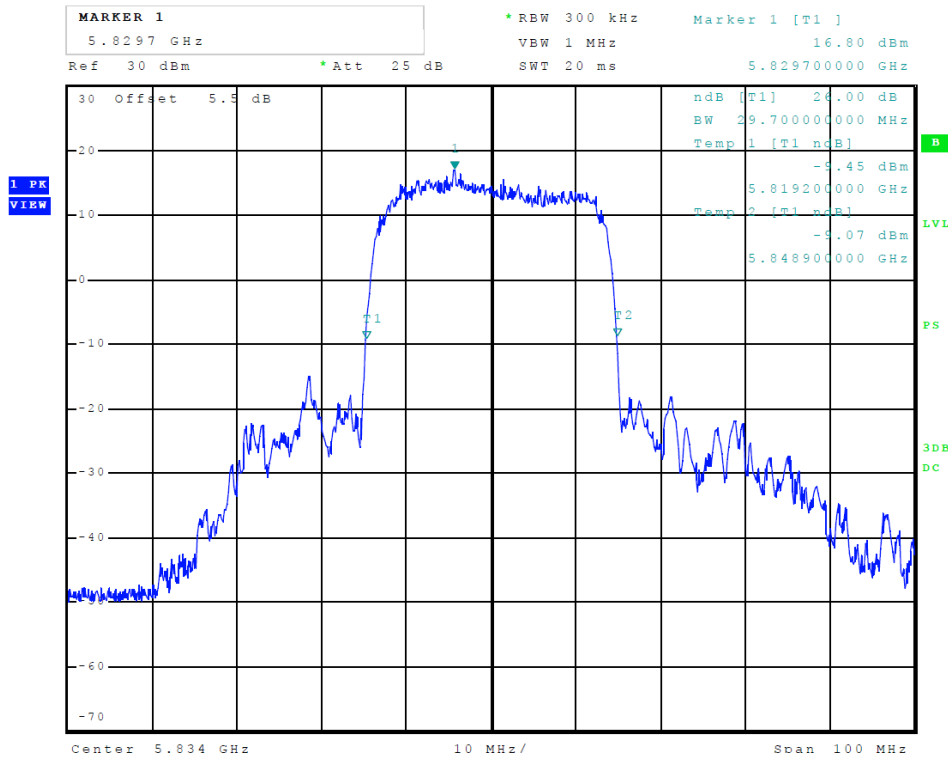

Figure 29 Plot of 26-dB OBW (28 MHz Channel)

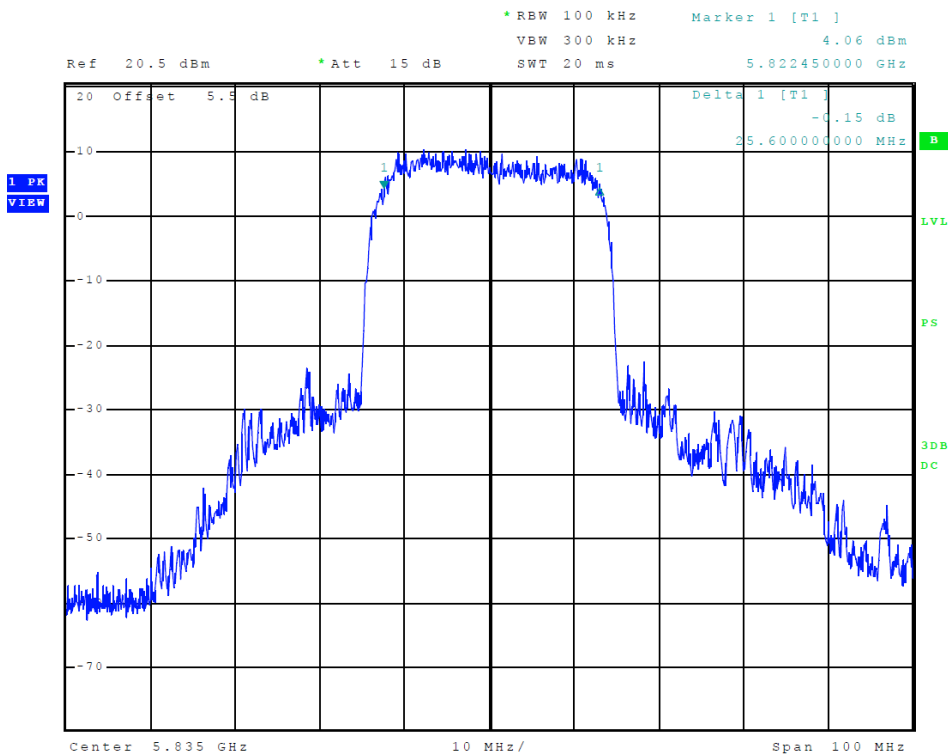

Figure 30 Plot of Minimum 6-dB Bandwidth (30 MHz Channel)

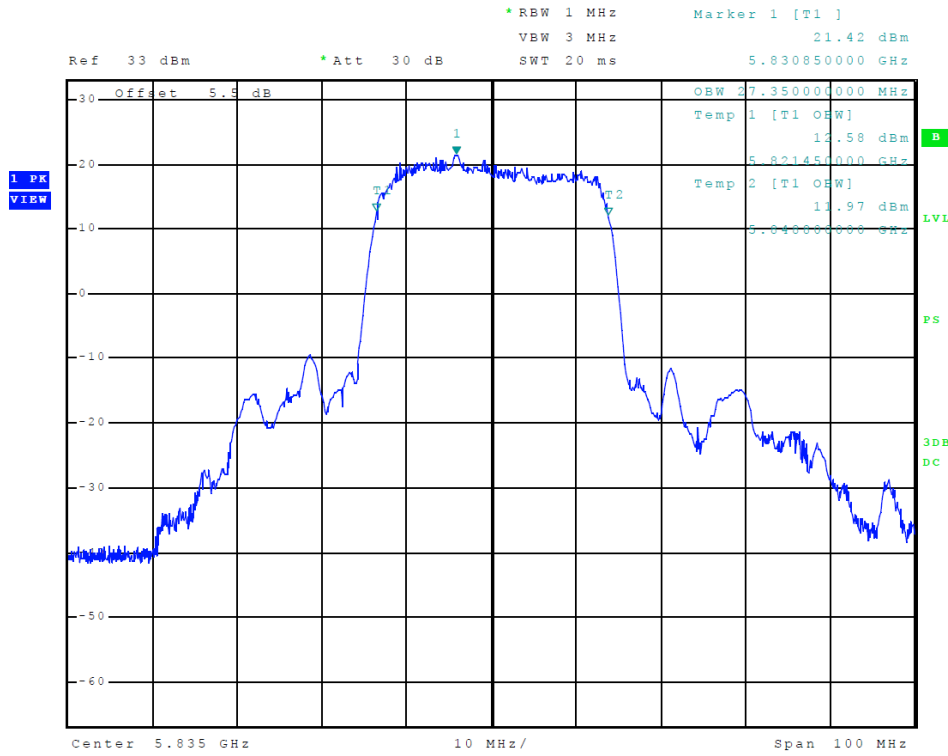

Figure 31 Plot of Transmitter 99% OBW (30 MHz Channel)

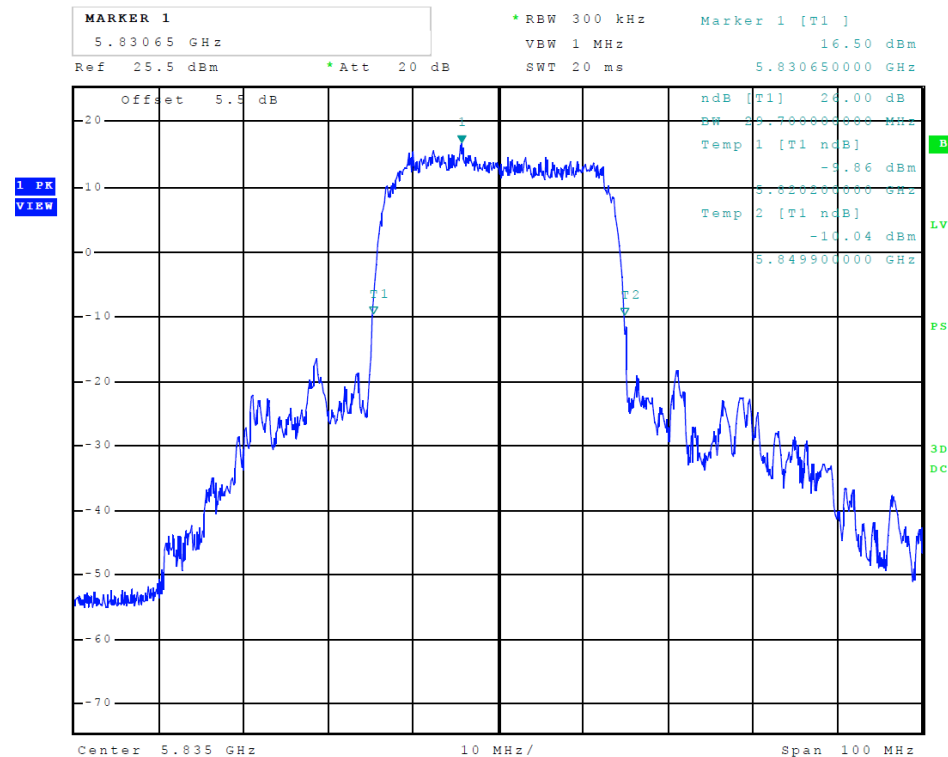

Figure 32 Plot of 26-dB OBW (30 MHz Channel)

TEST #6 Frequency Stability 15.407(g)

U-NII devices are responsible for ensuring frequency stability such that an emission is maintained within the band of operation. The manufacturer has attested the equipment will remain in the frequency band of operation under all normal operational use conditions. Additional temperature stability testing was performed, and stability verified. Testing was performed as defined in ANSI C63.10-2013.

Methods of Measurement Frequency Stability

ANSI C63.10-2013

6.8 Frequency stability tests

Some unlicensed wireless device requirements specify frequency stability tests with variation of supply voltage and temperature; the requirements can be found in the regulatory specifications for each type of unlicensed wireless device. The procedures listed in 6.8.1 and 6.8.2 shall be used for frequency stability tests.

6.8.1 Frequency stability with respect to ambient temperature

a) Supply the EUT with a nominal ac voltage or install a new or fully charged battery in the EUT. If possible, a dummy load shall be connected to the EUT because an antenna near the metallic walls of an environmental test chamber could affect the output frequency of the EUT. If the EUT is equipped with a permanently attached, adjustable-length antenna, then the EUT shall be placed in the center of the chamber with the antenna adjusted to the shortest length possible. Turn ON the EUT and tune it to one of the number of frequencies shown in 5.6.

b) Couple the unlicensed wireless device output to the measuring instrument by connecting an antenna to the measuring instrument with a suitable length of coaxial cable and placing the measuring antenna near the EUT (e.g., 15 cm away), or by connecting a dummy load to the measuring instrument, through an attenuator if necessary.

NOTE—An instrument that has an adequate level of accuracy as specified by the procuring or regulatory agency is the recommended measuring instrument.

c) Adjust the location of the measurement antenna and the controls on the measurement instrument to obtain a suitable signal level (i.e., a level that will not overload the measurement instrument but is strong enough to allow measurement of the operating or fundamental frequency of the EUT).

d) Turn the EUT OFF and place it inside the environmental temperature chamber. For devices that have oscillator heaters, energize only the heater circuit.

e) Set the temperature control on the chamber to the highest specified in the regulatory requirements for the type of device and allow the oscillator heater and the chamber temperature to stabilize.

f) While maintaining a constant temperature inside the environmental chamber, turn the EUT ON and record the operating frequency at startup, and at 2 minutes, 5 minutes, and 10 minutes after the EUT is energized. Four measurements in total are made.

g) Measure the frequency at each of frequencies specified in 5.6.

h) Switch OFF the EUT but do not switch OFF the oscillator heater.

i) Lower the chamber temperature by not more than 10 °C, and allow the temperature inside the chamber to stabilize.

j) Repeat step f) through step i) down to the lowest specified temperature.

6.8.2 Frequency stability when varying supply voltage

Unless otherwise specified, these tests shall be made at ambient room temperature (+15 °C to +25 °C). An antenna shall be connected to the antenna output terminals of the EUT if possible. If the EUT is equipped with or uses an adjustable-length antenna, then it shall be fully extended.

a) Supply the EUT with nominal voltage or install a new or fully charged battery in the EUT. Turn

ON the EUT and couple its output to a frequency counter or other frequency-measuring instrument.

NOTE—An instrument that has an adequate level of accuracy as specified by the procuring or regulatory agency is the recommended measuring instrument.

- b) Tune the EUT to one of the number of frequencies required in 5.6. Adjust the location of the measurement antenna and the controls on the measurement instrument to obtain a suitable signal level (i.e., a level that will not overload the measurement instrument but is strong enough to allow measurement of the operating or fundamental frequency of the EUT).
- c) Measure the frequency at each of the frequencies specified in 5.6.
- d) Repeat the above procedure at 85% and 115% of the nominal supply voltage as described in 5.13.

Test Arrangement Frequency Stability

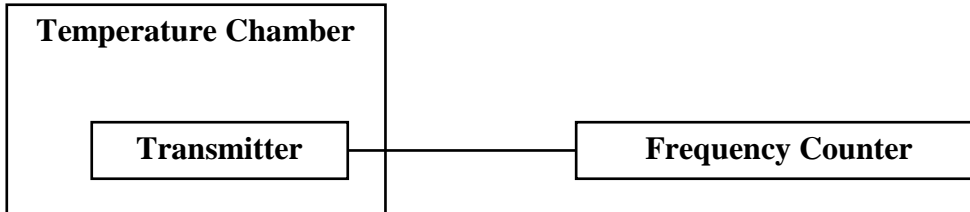

§15.407(g) General technical requirements

(g) Manufacturers of U-NII devices are responsible for ensuring frequency stability such that an emission is maintained within the band of operation under all conditions of normal operation as specified in the users manual.

Table 5 Frequency Stability vs. Temperature data

Frequency Stability Vs. Temperature Ambient Frequency 5835.017017 MHz									
Temperature °C	-30	-20	-10	0	+10	+20	+30	+40	+50
2 Minutes									
Change (Hz)	-2,249	-1,322	-777	-332	-139	-7	132	693	850
PPM	-0.385	-0.227	-0.133	-0.057	-0.024	-0.001	0.023	0.119	0.146
%	0.000	0.000	0.000	0.000	0.000	0.000	0.000	0.000	0.000
5 Minutes									
Change (Hz)	-2,040	-1,122	-733	-249	-119	4	238	754	950
PPM	-0.350	-0.192	-0.126	-0.043	-0.020	0.001	0.041	0.129	0.163
%	0.000	0.000	0.000	0.000	0.000	0.000	0.000	0.000	0.000
10 Minutes									
Change (Hz)	-1,897	-998	-589	-140	-39	15	338	799	980
PPM	-0.325	-0.171	-0.101	-0.024	-0.007	0.003	0.058	0.137	0.168
%	0.000	0.000	0.000	0.000	0.000	0.000	0.000	0.000	0.000

Table 6 Frequency Stability vs. Input Power Supply Voltage data

Frequency Stability Vs. Voltage Variation 120.0 AC volts nominal Ambient Frequency 5835.017017 MHz			
Voltage V _{dc}	102.0	120.0	138.0
Change (Hz)	-90	0	100
PPM	-0.014	0.000	0.019
%	0.000	0.000	0.000

TEST #7 Antenna Requirements 15.203

An intentional radiator shall be designed to ensure that no antenna other than that furnished by the responsible party shall be used with the device.

§15.203 Antenna requirement.

An intentional radiator shall be designed to ensure that no antenna other than that furnished by the responsible party shall be used with the device. The use of a permanently attached antenna or of an antenna that uses a unique coupling to the intentional radiator shall be considered sufficient to comply with the provisions of this section. The manufacturer may design the unit so that a broken antenna can be replaced by the user, but the use of a standard antenna jack or electrical connector is prohibited. This requirement does not apply to carrier current devices or to devices operated under the provisions of §§15.211, 15.213, 15.217, 15.219, 15.221, or §15.236. Further, this requirement does not apply to intentional radiators that must be professionally installed, such as perimeter protection systems and some field disturbance sensors, or to other intentional radiators which, in accordance with §15.31(d), must be measured at the installation site. However, the installer shall be responsible for ensuring that the proper antenna is employed so that the limits in this part are not exceeded.

The EUT provides single female-n coaxial cable connector port for use with authorized antennas. The design requires professional installation for compliance with unique antenna port connector requirements. The antenna connection provision complies with the unique antenna connection requirements. The requirements of 15.203 are fulfilled there are no deviations or exceptions to the specification.

TEST #8 Radiated Emissions in Restricted Bands of Operation 15.205

Spurious radiated emissions falling in the restricted frequency bands of operation were measured on the OATS. The EUT utilizes frequency, determining circuitry, which generates harmonics falling in restricted bands. Emissions testing as performed at the antenna port and as well as radiated emissions testing using all available modulations. Change in modulation had no impact on emission spectral profile. Antenna Port Conducted emission testing was performed in a screen room. Radiated emission testing was performed on the OATS measuring radiated emissions as required. Conducted and radiated emissions testing was performed as directed in 789033 D02 General UNII Test Procedures New Rules v01r04. Worst-case emissions are documented in this report.

Methods of Measurement Radiated Emissions in Restricted Bands

789033 D02 General UNII Test Procedures New Rules v01r04

G. Unwanted Emission Measurement

Note: Sections 1. and 2. below cover measurements in the restricted and non-restricted bands, respectively. However, those sections are not self-contained. Rather, they reference the general unwanted emissions measurement requirements in Section 3. and the specific measurement procedures in Sections 4., 5., and 6.

1. Unwanted Emissions in the Restricted Bands

a) For all measurements, follow the requirements in II.G.3. “*General Requirements for Unwanted Emissions Measurements.*”

b) At frequencies below 1000 MHz, use the procedure described in II.G.4. “*Procedure for Unwanted Emissions Measurements Below 1000 MHz.*”

c) At frequencies above 1000 MHz, measurements performed using the peak and average measurement procedures described in II.G.5. and II.G.6, respectively, must satisfy the respective peak and average limits. If all peak measurements satisfy the average limit, then average measurements are not required.

d) For *conducted* measurements above 1000 MHz, EIRP shall be computed as specified in II.G.3.b) and then field strength shall be computed as follows (see KDB Publication 412172):

(i) $E[\text{dB}\mu\text{V}/\text{m}] = \text{EIRP}[\text{dBm}] - 20 \log(d[\text{meters}]) + 104.77$, where E = field strength and d = distance at which field strength limit is specified in the rules;

(ii) $E[\text{dB}\mu\text{V}/\text{m}] = \text{EIRP}[\text{dBm}] + 95.2$, for d = 3 meters.

e) For *conducted* measurements below 1000 MHz, the field strength shall be computed as specified in d), above, and then an additional 4.7 dB shall be added as an upper bound on the field strength that would be observed on a test range with a ground plane for frequencies between 30 MHz and 1000 MHz, or an additional 6 dB shall be added for frequencies below 30 MHz.²

Test Arrangement Radiated Emissions in Restricted Bands

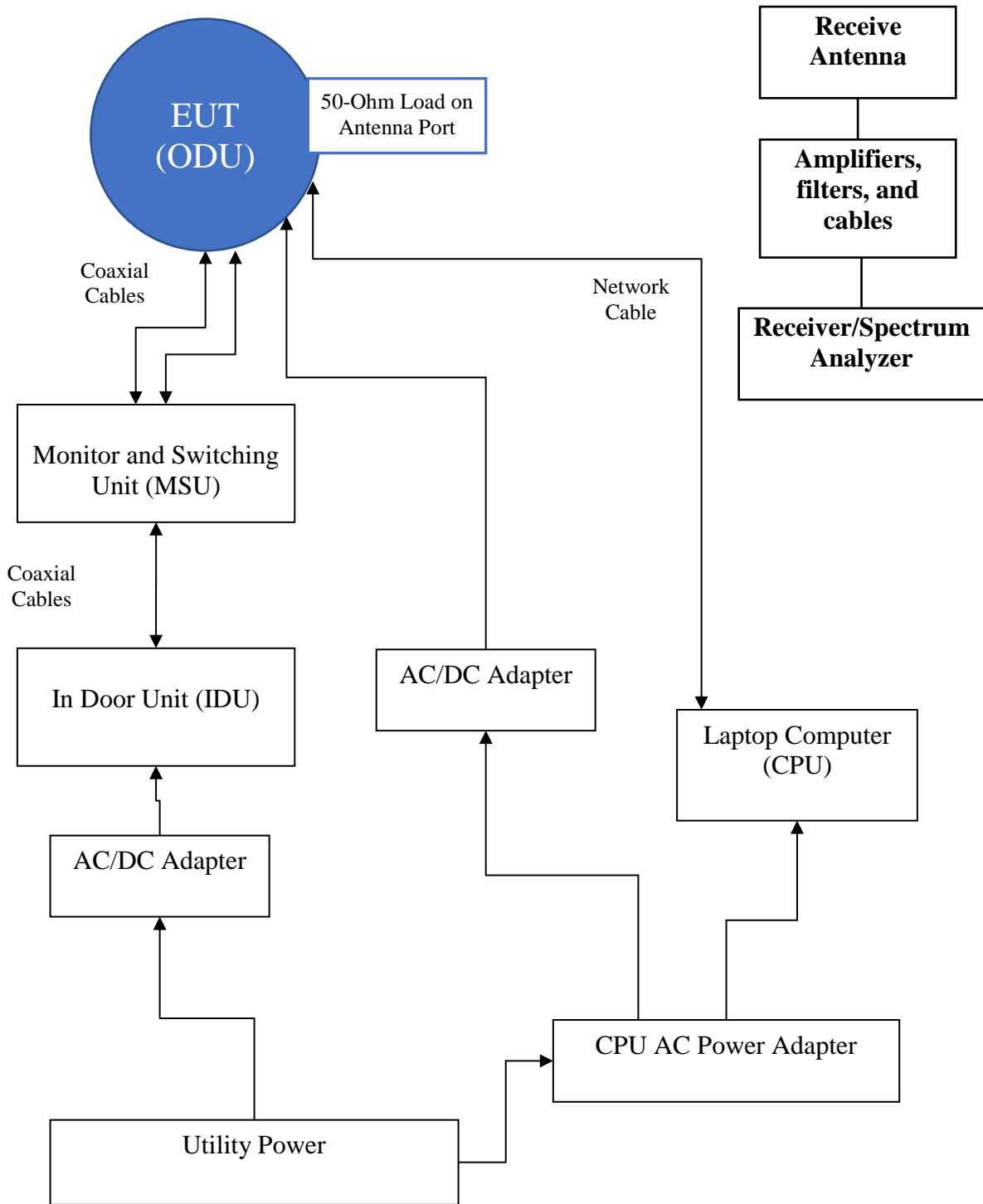

§15.407 General technical requirements

(b) *Undesirable emission limits.* Except as shown in paragraph (b)(7) of this section, the maximum emissions outside of the frequency bands of operation shall be attenuated in accordance with the following limits:

(7) The provisions of §15.205 apply to intentional radiators operating under this section.

§ 15.205 Restricted bands of operation.

(a) Except as shown in paragraph (d) of this section, only spurious emissions are permitted in any of the frequency bands listed below:

MHz	MHz	MHz	GHz
0.090-0.110	16.42-16.423	399.9-410	4.5-5.15
¹ 0.495-0.505	16.69475-16.69525	608-614	5.35-5.46
2.1735-2.1905	16.80425-16.80475	960-1240	7.25-7.75
4.125-4.128	25.5-25.67	1300-1427	8.025-8.5
4.17725-4.17775	37.5-38.25	1435-1626.5	9.0-9.2
4.20725-4.20775	73-74.6	1645.5-1646.5	9.3-9.5
6.215-6.218	74.8-75.2	1660-1710	10.6-12.7
6.26775-6.26825	108-121.94	1718.8-1722.2	13.25-13.4
6.31175-6.31225	123-138	2200-2300	14.47-14.5
8.291-8.294	149.9-150.05	2310-2390	15.35-16.2
8.362-8.366	156.52475-156.52525	2483.5-2500	17.7-21.4
8.37625-8.38675	156.7-156.9	2690-2900	22.01-23.12
8.41425-8.41475	162.0125-167.17	3260-3267	23.6-24.0
12.29-12.293	167.72-173.2	3332-3339	31.2-31.8
12.51975-12.52025	240-285	3345.8-3358	36.43-36.5
12.57675-12.57725	322-335.4	3600-4400	(²)
13.36-13.41			

Table 7 Radiated Emissions in Restricted Bands Data

Frequency in MHz	Horizontal Peak (dB μ V/m)	Horizontal Quasi-Peak (dB μ V/m)	Horizontal Average (dB μ V/m)	Vertical Peak (dB μ V/m)	Vertical Quasi-Peak (dB μ V/m)	Vertical Average (dB μ V/m)	Limit @ 3m (dB μ V/m)	Pass/Fail
11480.0	50.5	N/A	38.0	50.7	N/A	37.9	54.0	Pass
11670.0	52.4	N/A	39.6	52.1	N/A	39.6	54.0	Pass
22960.0	52.3	N/A	39.1	51.7	N/A	38.5	54.0	Pass

Other emissions present had amplitudes at least 20 dB below the limit. Peak and Quasi-Peak amplitude emissions are recorded above for frequency range below 1000 MHz. Peak and Average amplitude emissions are recorded above for frequency range above 1000 MHz.

Summary of Results for Radiated Emissions in Restricted Bands

The EUT demonstrated compliance with the emissions requirements of 47CFR 15.205, 15.407, RSS-GEN and RSS-247 Issue 2 Intentional Radiators. The EUT provided a worst-case minimum margin of -14.4 dB below the emissions requirements in restricted frequency bands. Peak, Quasi-peak, and average amplitudes were checked for compliance with the regulations. Worst-case emissions are reported with other emissions found in the restricted frequency bands at least 20 dB below the requirements.

TEST #9 AC Line Conducted Emissions 15.207

Testing for radio frequency voltage conducted back onto the AC power line on frequencies within the band 150 kHz to 30 MHz were performed. Ac Line Conducted emissions testing was performed as defined in ANSI C63.10-2013

Methods of Measurement AC Line Conducted Emissions

6.2.5 Final ac power-line conducted emission measurements

Based on the exploratory tests of the EUT performed in 6.2.4, the one EUT cable configuration and arrangement and mode of operation that produced the emission with the highest amplitude relative to the limit is selected for the final measurement, while applying the appropriate modulating signal to the EUT. If the EUT is relocated from an exploratory test site to a final test site, the highest emissions shall be remaximized at the final test location before final ac power-line conducted emission measurements are performed. The final test on all current-carrying conductors of all of the power cords to the equipment that comprises the EUT (but not the cords associated with other non-EUT equipment in the system) is then performed for the full frequency range for which the EUT is being tested for compliance without further variation of the EUT arrangement, cable positions, or EUT mode of operation. If the EUT is composed of equipment units that have their own separate ac power connections (e.g., floor-standing equipment with independent power cords for each shelf that are able to connect directly to the ac power network), then each current-carrying conductor of one unit is measured while the other units are connected to a second (or more) LISN(s). All units shall be measured separately. If a power strip is provided by the manufacturer, to supply all of the units making up the EUT, only the conductors in the power cord of the power strip shall be measured.

If the EUT operates above 30 MHz and uses a detachable antenna, then these measurements shall be made with a representative antenna connected to the antenna output terminals. These tests shall be made with the antenna connected and, if adjustable, fully extended.⁴⁴

Record the six highest EUT emissions relative to the limit of each of the current-carrying conductors of the power cords of the equipment that comprises the EUT over the frequency range specified by the procuring or regulatory agency.

The EUT was arranged in a typical equipment configuration and placed on a 1 x 1.5-meter wooden bench 80 cm above the conducting ground plane, floor of a screen room. The bench was positioned 40 cm away from the wall of the screen room. The LISN was positioned on the floor of the screen room 80-cm from the rear of the EUT. The manufacturer supplied supporting equipment In Door Unit provided direct current power to the EUT was connected to the LISN for power Line conducted emissions testing. A second LISN was positioned on the floor of the screen room 80-cm from the rear of the supporting equipment of the EUT. All power cords except the EUT were then powered from the second LISN. EMI was coupled to the spectrum analyzer through a 0.1 µf capacitor, internal to the LISN. Power line conducted emissions testing were carried out individually for each current carrying conductor of the EUT. The excess length of lead between the system and the LISN receptacle was

folded back and forth to form a bundle not exceeding 40 cm in length. The screen room, conducting ground plane, analyzer, and LISN were bonded together to the protective earth ground. Preliminary testing was performed to identify the frequency of each emission displaying the highest amplitude. The cables were repositioned to obtain maximum amplitude of measured EMI level. Once the worst-case configuration was identified, plots were made of the EMI from 0.15 MHz to 30 MHz then the data was recorded with maximum conducted emissions levels. Refer to figures forty-one and forty-two for plots of the EUT AC Line Conducted emissions.

Test Arrangement AC Line Conducted Emissions

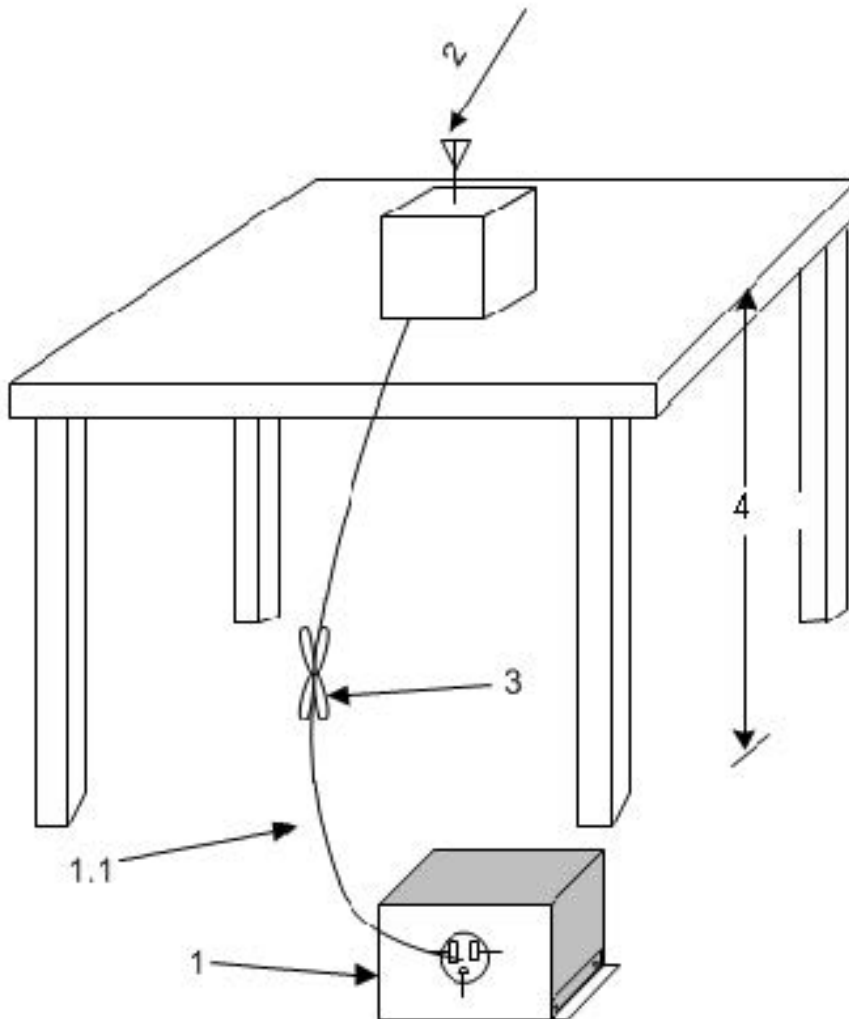

§15.407 General technical requirements.

(b) *Undesirable emission limits.* Except as shown in paragraph (b)(7) of this section, the maximum emissions outside of the frequency bands of operation shall be attenuated in accordance with the following limits:

(6) Unwanted emissions below 1 GHz must comply with the general field strength limits set forth in §15.209. Further, any U-NII devices using an AC power line are required to comply also with the conducted limits set forth in §15.207.

§15.207 Conducted limits.

(a) Except as shown in paragraphs (b) and (c) of this section, for an intentional radiator that is designed to be connected to the public utility (AC) power line, the radio frequency voltage that is conducted back onto the AC power line on any frequency or frequencies, within the band 150 kHz to 30 MHz, shall not exceed the limits in the following table, as measured using a 50 µHy/50 ohms line impedance stabilization network (LISN). Compliance with the provisions of this paragraph shall be based on the measurement of the radio frequency voltage between each power line and ground at the power terminal. The lower limit applies at the boundary between the frequency ranges.

Frequency of emission (MHz)	Conducted limit (dBµV)	
	Quasi-peak	Average
0.15-0.5	66 to 56*	56 to 46*
0.5-5	56	66
5-30	60	50

*Decreases with the logarithm of the frequency.

Table 8 AC Line Conducted Emissions Data (Highest Emissions Line L1)

Trace	Frequency	Level (dBµV)	Detector	Delta Limit/dB
1	18.244000000 MHz	45.04	Quasi Peak	-14.96
1	19.708000000 MHz	48.81	Quasi Peak	-11.19
2	19.712000000 MHz	43.11	Average	-6.89
2	20.256000000 MHz	45.57	Average	-4.43
1	20.260000000 MHz	48.83	Quasi Peak	-11.17
2	20.808000000 MHz	45.49	Average	-4.51
1	20.808000000 MHz	48.28	Quasi Peak	-11.72
2	21.660000000 MHz	45.31	Average	-4.69
1	21.664000000 MHz	49.84	Quasi Peak	-10.16
2	22.212000000 MHz	42.62	Average	-7.38
2	23.128000000 MHz	45.87	Average	-4.13
1	23.128000000 MHz	48.65	Quasi Peak	-11.35

Other emissions present had amplitudes at least 20 dB below the limit.

Table 9 AC Line Conducted Emissions Data (Highest Emissions Line L2)

Trace	Frequency	Level (dBµV)	Detector	Delta Limit/dB
1	18.244000000 MHz	46.84	Quasi Peak	-13.16
2	18.244000000 MHz	44.71	Average	-5.29
1	18.916000000 MHz	44.37	Quasi Peak	-15.63
2	18.916000000 MHz	41.92	Average	-8.08
2	19.708000000 MHz	44.21	Average	-5.79
1	19.708000000 MHz	46.57	Quasi Peak	-13.43
2	20.256000000 MHz	41.94	Average	-8.06
1	20.260000000 MHz	45.05	Quasi Peak	-14.95
2	21.664000000 MHz	42.21	Average	-7.79
1	21.664000000 MHz	44.87	Quasi Peak	-15.13
2	23.128000000 MHz	43.32	Average	-6.68
1	23.128000000 MHz	46.00	Quasi Peak	-14.00

Other emissions present had amplitudes at least 20 dB below the limit.

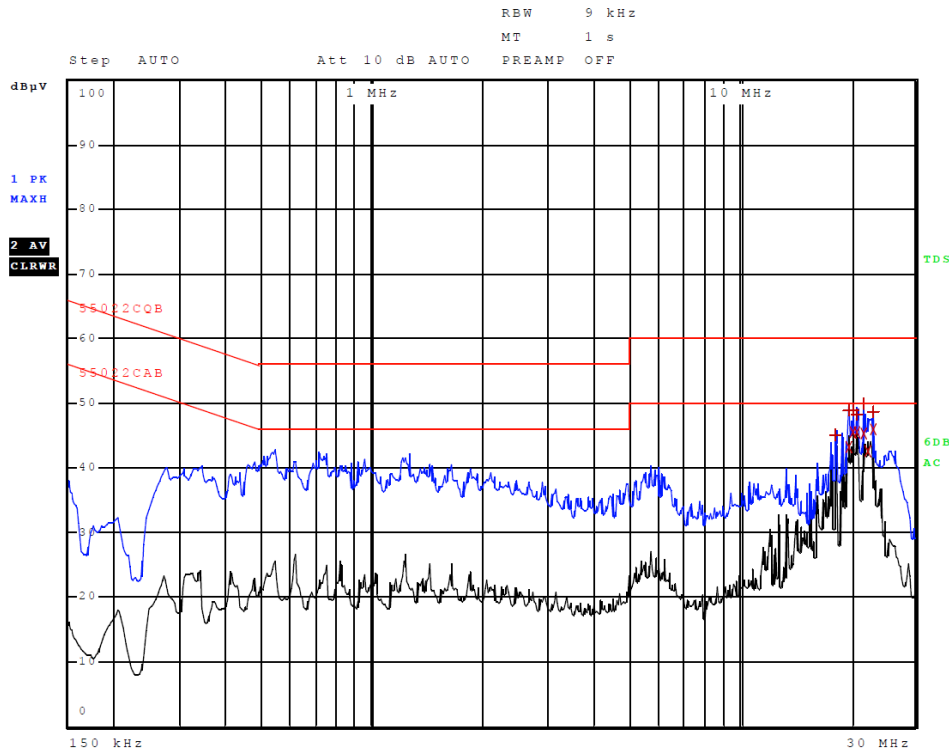

Figure 33 Plot of AC Line Conducted Emissions Line 1

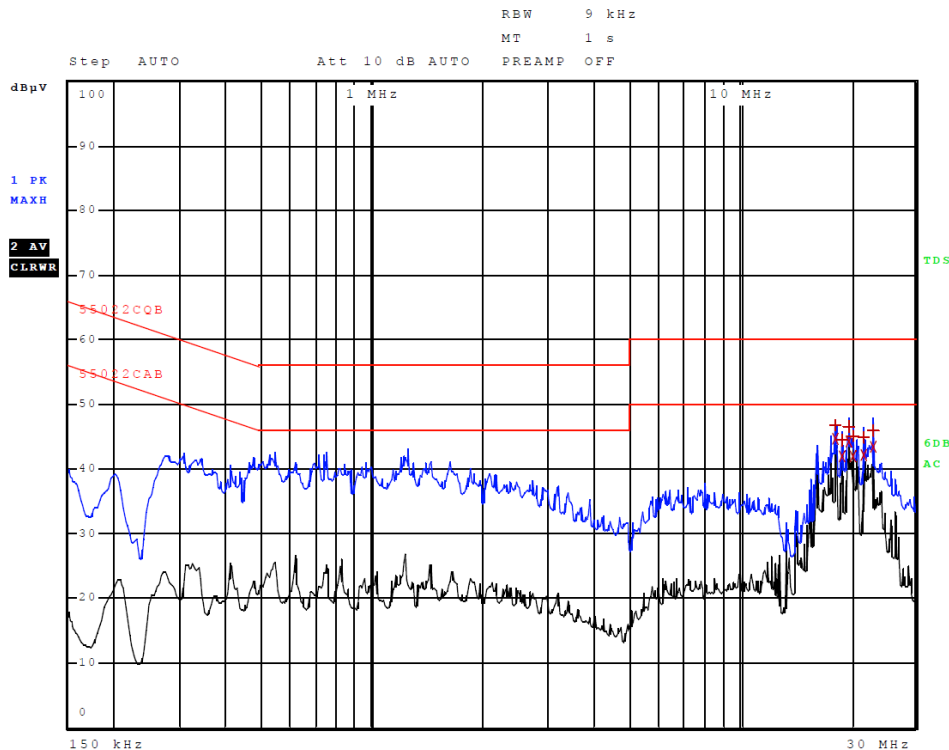

Figure 34 Plot of AC Line Conducted Emissions Line 2

Summary of Results for AC Line Conducted Emissions

Pass - The EUT test system demonstrated compliance to the conducted emissions requirements of 47CFR 15.207, RSS-247 Issue 2 and RSS-GEN. The EUT demonstrated minimum margin of -18.8 dB below the limit. Measurements were taken using the peak, quasi peak, and average, measurement function for each emissions amplitude and were below the limits stated in the specification. Other emissions were present with recorded data representing worst-case amplitudes.

TEST #10 Radiated Emissions, General requirements 15.209

The emissions from an intentional radiator shall not exceed the field strength levels specified.

Radiated emission testing was performed on the OATS measuring radiated emissions as required. Radiated emissions testing was performed as directed in ANSI C63-10-2013.

Worst-case emissions are documented in this report

Methods of Measurement Radiated Emissions, General requirements

ANSI C63.10-2013

6.4 Radiated emissions from unlicensed wireless devices below 30 MHz

6.4.1 General

This subclause contains procedures for compliance testing below 30 MHz. Unlicensed wireless devices that are too large for a test site shall be tested for compliance at the manufacturer's facility or in situ; see the procedures in 6.11.

6.5 Radiated emissions from unlicensed wireless devices in the frequency range of 30 MHz to 1000 MHz

This subclause specifies conditions for compliance testing in the frequency range above 30 MHz and below 1 GHz. The following subclauses describe the procedures that shall be used for making exploratory and final radiated emission tests for frequencies between 30 MHz and 1000 MHz. Measurements may be performed at a distance closer than that specified in the requirements, provided the measuring antenna is beyond its near-field range as determined by the Rayleigh criteria.

6.6 Radiated emissions from unlicensed wireless devices above 1 GHz

6.6.1 General requirements

This subclause specifies procedures for testing unlicensed wireless devices for radiated emissions for frequencies above 1 GHz. These procedures are in addition to the procedures in 6.3. General guidance for instrumentation and measurement issues above 1 GHz is contained in Annex E.

The EUT was arranged in a typical equipment configuration and operated through all available modes with worst-case data recorded. Preliminary testing was performed in a screen room with the EUT positioned 1 meter from the FSM. Radiated emissions measurements were performed to identify the frequencies, which produced the highest emissions. Each radiated emission was then maximized at the OATS location before final radiated emissions measurements were performed. Final data was taken with the EUT located at the OATS at a distance of 3 meters between the EUT and the receiving antenna. The frequency spectrum from 9 kHz to 60,000 MHz was searched for general radiated emissions. Measured emission levels were maximized by EUT placement on the table, rotating the turntable through 360 degrees, varying the antenna height between 1 and 4 meters above the ground plane and changing antenna position between horizontal and vertical polarization. Antennas used were Loop from 9 kHz to 30 MHz, Broadband Biconical from 30 to 200 MHz, Biconilog from 30 to 1000 MHz, Log Periodic from 200

MHz to 1 GHz and or Double Ridge or pyramidal horns and mixers above 1 GHz, notch filters, and appropriate amplifiers and external mixers were utilized.

Radiated Emissions emanating from the equipment were investigated while the EUT was located on the OATS using appropriate antennas or pyramidal horns, amplification stages, and spectrum analyzer receiver. Peak and average amplitudes of frequencies above 1000 MHz were compared to the required limits with worst-case data presented below. Test procedures of ANSI C63.10-2013 were used during testing. No other significant emission was observed which fell into the restricted bands of operation. Computed radiated emission values consider the measured radiated field strength, receive antenna correction factor, amplifier gain stage, and test system cable losses. The spectrum analyzer was used to observe the radio frequency spectrum with the transmitter operated in all normal modes. The frequency spectrum from 0.009 MHz to 60,000 MHz was investigated.

Test Arrangement Radiated Emissions

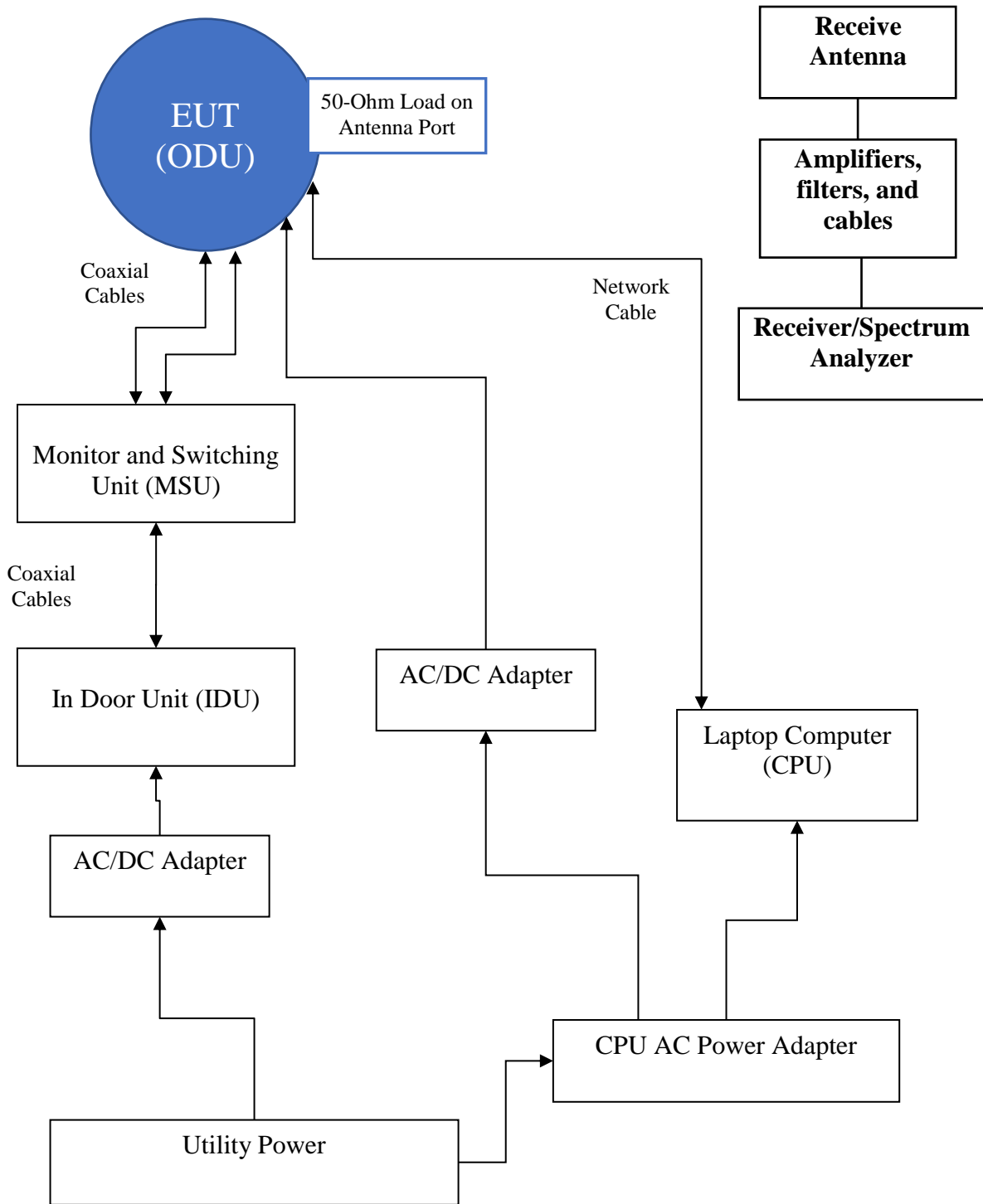

§15.407 General technical requirements.

(b) *Undesirable emission limits.* Except as shown in paragraph (b)(7) of this section, the maximum emissions outside of the frequency bands of operation shall be attenuated in accordance with the following limits:

(6) Unwanted emissions below 1 GHz must comply with the general field strength limits set forth in §15.209. Further, any U-NII devices using an AC power line are required to comply also with the conducted limits set forth in §15.207.

§15.209 Radiated emission limits; general requirements.

(a) Except as provided elsewhere in this subpart, the emissions from an intentional radiator shall not exceed the field strength levels specified in the following table:

Frequency (MHz)	Field strength (microvolts/meter) / dBµV/m	Measurement distance (meters)
0.009-0.490	2400/F(kHz) / 67.6/F(kHz)	300
0.490-1.705	24000/F(kHz) / 87.6/ F(kHz)	30
1.705-30.0	30 / 29.5	30
30-88	100** / 40.0	3
88-216	150** / 43.5	3
216-960	200** / 46.0	3
Above 960	500 / 54.0	3

**Except as provided in paragraph (g), fundamental emissions from intentional radiators operating under this section shall not be located in the frequency bands 54-72 MHz, 76-88 MHz, 174-216 MHz or 470-806 MHz. However, operation within these frequency bands is permitted under other sections of this part, e.g., §§15.231 and 15.241.

Table 10 General Radiated Emissions from EUT Data (Highest Emissions)

Frequency in MHz	Horizontal Peak (dBµV/m)	Horizontal Quasi-Peak (dBµV/m)	Horizontal Average (dBµV/m)	Vertical Peak (dBµV/m)	Vertical Quasi-Peak (dBµV/m)	Vertical Average (dBµV/m)	Limit @ 3m (dBµV/m)	Pass/Fail
50.4	38.6	31.5	N/A	38.5	33.1	N/A	40.0	Pass
55.9	38.2	31.0	N/A	42.3	36.5	N/A	40.0	Pass
63.0	36.9	29.6	N/A	39.4	34.0	N/A	40.0	Pass
77.2	36.6	31.4	N/A	37.1	32.1	N/A	40.0	Pass
82.9	38.8	30.8	N/A	40.9	35.1	N/A	40.0	Pass
106.7	36.1	30.1	N/A	34.3	30.5	N/A	43.5	Pass
108.8	35.1	26.0	N/A	36.1	30.2	N/A	43.5	Pass
375.0	40.0	38.3	N/A	38.1	36.6	N/A	46.0	Pass
560.0	37.3	32.3	N/A	37.3	34.9	N/A	46.0	Pass

Other emissions present had amplitudes at least 20 dB below the limit. Peak and Quasi-Peak amplitude emissions are recorded above for frequency range below 1000 MHz. Peak and Average amplitude emissions are recorded above for frequency range above 1000 MHz.

Summary of Results for General Radiated Emissions

Pass- The EUT demonstrated compliance with the radiated emissions requirements of 47CFR part 15 and Industry Canada RSS-247 Issue 2 Intentional Radiators. The EUT demonstrated a minimum margin of -3.5 dB below the requirements. Other emissions were present with amplitudes at least 20 dB below the Limits.

Summary of Results for Transmitter Radiated Emissions of Intentional Radiator

The EUT demonstrated compliance with the radiated emissions requirements of 47CFR Part 15.407 and Industry Canada RSS-247 Issue 2. The output power is manufacturer adjustable from 8 dBm to 27 dBm and installers may adjust during installation. The adjustments are available to manufacturer and installers. End users are denied access to the power settings as attested by manufacturer. The maximum measured peak conducted output power delivered into the antenna port was 1.00-Watts. The minimum harmonic radiated emission margin provided -21.6 dB margin below requirements. General radiated emissions of EUT and supporting equipment provided -3.5 dB margin. There were no other significantly measurable emissions in the restricted bands other than those recorded in this report. Other emissions were present with amplitudes at least 20 dB below the requirements. There were no other deviations or exceptions to the requirements.

Statement of Modifications and Deviations

No modifications to the EUT were required for the unit to demonstrate compliance with the 47CFR Part 15E paragraph 15.407 and Industry Canada RSS-247 Issue 2 emissions requirements. There were no deviations or modifications to the specifications.

Annex

- Annex A Measurement Uncertainty Calculations
- Annex B Rogers Labs Test Equipment List
- Annex C Rogers Qualifications
- Annex D Rogers Labs Certificate of Accreditation

Rogers Labs, Inc.
4405 W. 259th Terrace
Louisburg, KS 66053

Phone/Fax: (913) 837-3214

Revision 2

SAF Tehnika AS

Models: CFL Sprint MXM Repeater

Test #: 170615A

Test to: 47CFR, 15.407, RSS-247

File: SAF Tehnika 58F2DMXMR FCC UNII TstRpt 170615A r2

S/N's: 348650100197/34866000196

FCC ID: W9Z-58F2DMXMR

IC: 8855A-58F2DMXMR

Date: November 29, 2017

Page 82 of 86

Annex A Measurement Uncertainty Calculations

Measurement uncertainty calculations were made for the laboratory. Result of measurement uncertainty calculations are recorded below for AC line conducted and radiated emission measurements.

Measurement Uncertainty	$U_{(E)}$	$U_{(lab)}$
3 Meter Horizontal 30-200 MHz Measurements	2.08	4.16
3 Meter Vertical 30-200 MHz Measurements	2.16	4.33
3 Meter Vertical Measurements 200-1000 MHz	2.99	5.97
10 Meter Horizontal Measurements 30-200 MHz	2.07	4.15
10 Meter Vertical Measurements 30-200 MHz	2.06	4.13
10 Meter Horizontal Measurements 200-1000 MHz	2.32	4.64
10 Meter Vertical Measurements 200-1000 MHz	2.33	4.66
3 Meter Measurements 1-6 GHz	2.57	5.14
3 Meter Measurements 6-18 GHz	2.58	5.16
AC Line Conducted	1.72	3.43

Annex B Rogers Labs Test Equipment List

List of Test Equipment	Calibration	Date	Due
Spectrum Analyzer: Rohde & Schwarz ESU40		5/17	5/18
Spectrum Analyzer: HP 8562A, HP Adapters: 11518, 11519, and 11520		5/17	5/18
Mixers: 11517A, 11970A, 11970K, 11970U, 11970V, 11970W			
Spectrum Analyzer: HP 8591EM		5/17	5/18
Antenna: EMCO Biconilog Model: 3143		5/17	5/18
Antenna: Sunol Biconilog Model: JB6		10/16	10/17
Antenna: EMCO Log Periodic Model: 3147		10/16	10/17
Antenna: Com Power Model: AH-118		10/16	10/17
Antenna: Com Power Model: AH-840		5/17	5/18
Antenna: Antenna Research Biconical Model: BCD 235		10/16	10/17
Antenna: Com Power Model: AL-130		10/16	10/17
Antenna: EMCO 6509		10/16	10/17
LISN: Compliance Design Model: FCC-LISN-2.Mod.cd, 50 µHy/50 ohm/0.1 µf		10/16	10/17
R.F. Preamp CPPA-102		10/16	10/17
Attenuator: HP Model: HP11509A		10/16	10/17
Attenuator: Mini Circuits Model: CAT-3		10/16	10/17
Attenuator: Mini Circuits Model: CAT-3		10/16	10/17
Cable: Belden RG-58 (L1)		10/16	10/17
Cable: Belden RG-58 (L2)		10/16	10/17
Cable: Belden 8268 (L3)		10/16	10/17
Cable: Time Microwave: 4M-750HF290-750		10/16	10/17
Cable: Time Microwave: 10M-750HF290-750		10/16	10/17
Frequency Counter: Leader LDC825		2/17	2/18
Oscilloscope Scope: Tektronix 2230		2/17	2/18
Wattmeter: Bird 43 with Load Bird 8085		2/17	2/18
Power Supplies: Sorensen SRL 20-25, SRL 40-25, DCR 150, DCR 140		2/17	2/18
R.F. Generators: HP 606A, HP 8614A, HP 8640B		2/17	2/18
R.F. Power Amp 65W Model: 470-A-1010		2/17	2/18
R.F. Power Amp 50W M185- 10-501		2/17	2/18
R.F. Power Amp A.R. Model: 10W 1010M7		2/17	2/18
R.F. Power Amp EIN Model: A301		2/17	2/18
LISN: Compliance Eng. Model 240/20		2/17	2/18
LISN: Fischer Custom Communications Model: FCC-LISN-50-16-2-08		2/17	2/18
Antenna: EMCO Dipole Set 3121C		2/17	2/18
Antenna: C.D. B-101		2/17	2/18
Antenna: Solar 9229-1 & 9230-1		2/17	2/18
Audio Oscillator: H.P. 201CD		2/17	2/18
ESD Test Set 2010i		2/17	2/18
Fast Transient Burst Generator Model: EFT/B-101		2/17	2/18
Field Intensity Meter: EFM-018		2/17	2/18
KEYTEK Ecat Surge Generator		2/17	2/18
Shielded Room 5 M x 3 M x 3.0 M			

Annex C Rogers Qualifications

Scot D. Rogers, Engineer

Rogers Labs, Inc.

Mr. Rogers has approximately 17 years' experience in the field of electronics. Engineering experience includes six years in the automated controls industry and remaining years working with the design, development and testing of radio communications and electronic equipment.

Positions Held

Systems Engineer: A/C Controls Mfg. Co., Inc. 6 Years

Electrical Engineer: Rogers Consulting Labs, Inc. 5 Years

Electrical Engineer: Rogers Labs, Inc. Current

Educational Background

- 1) Bachelor of Science Degree in Electrical Engineering from Kansas State University.
- 2) Bachelor of Science Degree in Business Administration Kansas State University.
- 3) Several Specialized Training courses and seminars pertaining to Microprocessors and Software programming.

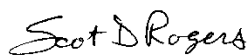

Scot D. Rogers

Annex D Rogers Labs Certificate of Accreditation

United States Department of Commerce
National Institute of Standards and Technology



Certificate of Accreditation to ISO/IEC 17025:2005

NVLAP LAB CODE: 200087-0

Rogers Labs, Inc.
Louisburg, KS

*is accredited by the National Voluntary Laboratory Accreditation Program for specific services,
listed on the Scope of Accreditation, for:*

Electromagnetic Compatibility & Telecommunications

*This laboratory is accredited in accordance with the recognized International Standard ISO/IEC 17025:2005.
This accreditation demonstrates technical competence for a defined scope and the operation of a laboratory quality
management system (refer to joint ISO-ILAC-IAF Communique dated January 2009).*

2017-03-01 through 2018-03-31
Effective Dates



For the National Voluntary Laboratory Accreditation Program

Rogers Labs, Inc.
4405 W. 259th Terrace
Louisburg, KS 66053
Phone/Fax: (913) 837-3214
Revision 2

SAF Tehnika AS
Models: CFL Sprint MXM Repeater
Test #: 170615A
Test to: 47CFR, 15.407, RSS-247

S/N's: 348650100197/34866000196
FCC ID: W9Z-58F2DMXMR
IC: 8855A-58F2DMXMR
Date: November 29, 2017